

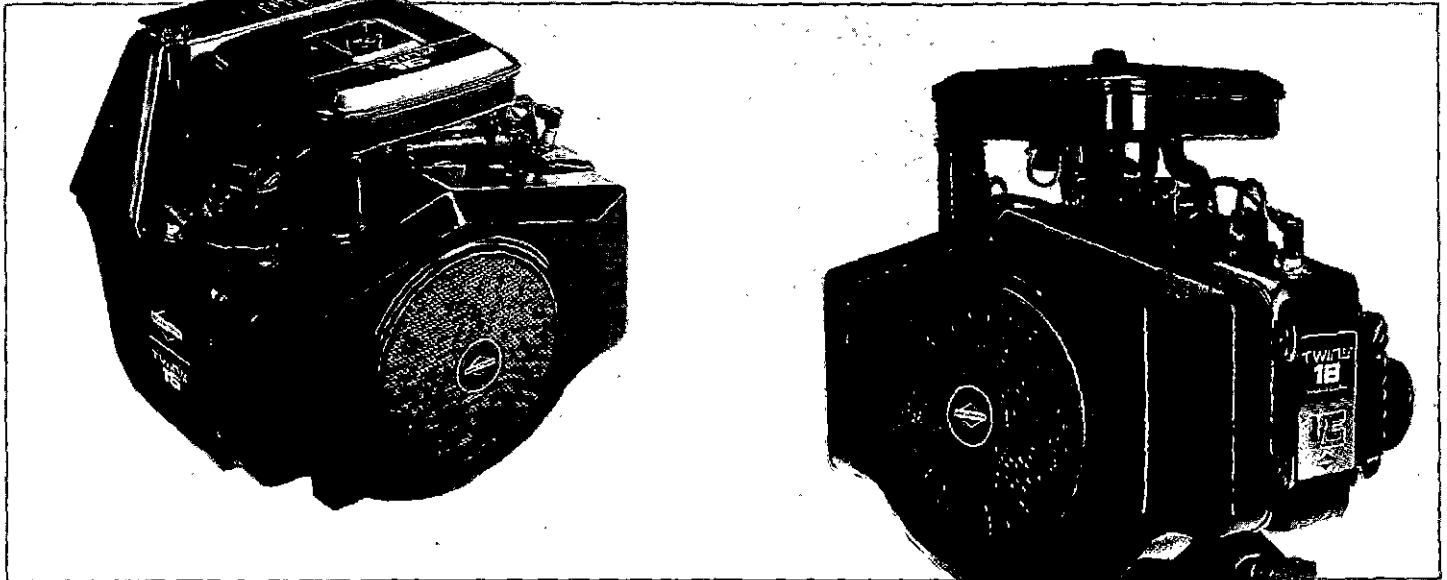

**Operating and Maintenance Instructions for
Model Series 400400 (14 HP), 402400 (16 HP),
404400 (12.5 HP) & 422400 (18 HP)**



Briggs & Stratton Corporation
Milwaukee, Wisconsin 53201

© Copyright 1989 by Briggs & Stratton Corporation

FORM NO. 272111-11/89
PRINTED IN U.S.A.

In The Interest Of Safety



THIS SYMBOL MEANS **WARNING** OR **CAUTION**. PERSONAL INJURY AND/OR PROPERTY DAMAGE MAY OCCUR UNLESS INSTRUCTIONS ARE FOLLOWED CAREFULLY.



WARNING

1. DO NOT run engine in an enclosed area. Exhaust gases contain carbon monoxide, an odorless and deadly poison.
2. DO NOT check for spark with spark plugs or spark plug wires removed. Use an approved tester.
3. DO NOT crank engine with spark plugs removed. If engine is flooded, place throttle in "FAST" position and crank until engine starts.
4. DO NOT smoke when filling fuel tank.
5. DO NOT fill fuel tank while engine is running. Allow engine to cool for two minutes before refueling.
6. DO NOT operate engine when an odor of gasoline is present or other explosive conditions exist.
7. DO NOT operate engine if gasoline is spilled. Move machine away from the spill and avoid creating any ignition until the gasoline has evaporated.
8. DO NOT STORE, SPILL, OR USE GASOLINE NEAR AN OPEN FLAME, or devices such as a stove, furnace, or water heater which utilize a pilot light or devices which can create a spark.
9. DO NOT refuel indoors where area is not well ventilated. Outdoor refueling is preferred.

10. DO NOT OPERATE ENGINE WITHOUT MUFFLER(s). Inspect periodically and replace if necessary.
11. DO NOT operate engine with an accumulation of grass, leaves, dirt or other combustible material in the muffler area.
12. DO NOT use this engine on any forest covered, brush covered, or grass covered unimproved land unless spark arrester(s) is/are installed on the muffler.
13. DO NOT run engine with air cleaner or air cleaner cover removed.



CAUTION

1. DO NOT RUN ENGINE AT EXCESSIVE SPEEDS, AS THIS MAY RESULT IN INJURY.
2. DO NOT tamper with governor springs, governor links or other parts which may increase the governed engine speed.
3. DO NOT tamper with the engine speed selected by the original equipment manufacturer.
4. DO NOT touch hot muffler(s), cylinders, or fins as contact may cause burns.
5. DO NOT place hands or feet near moving or rotating parts.
6. DO keep cylinder fins and governor parts free of grass and other debris as this can affect engine speed.
7. DO pull starter cord slowly until resistance is felt. Then pull cord rapidly to avoid kickback and prevent hand or arm injury.

8. TO PREVENT ACCIDENTAL STARTING when servicing the engine or equipment, always move the spark plugs or wires from the spark plugs. Disconnect negative wire from battery terminal if equipped with a 12 volt starting system.
9. DO use fresh gasoline. Stale fuel can cause leakage.

WHEN WORKING ON EQUIPMENT

DO NOT STRIKE FLYWHEEL with a hard object or metal tool as this may cause flywheel to shatter in operation, causing personal injury or property damage. To remove flywheel, use Briggs & Stratton approved tools only.

The use of Briggs & Stratton parts preserves the original design of your engine. Imitation replacement parts offer potential risk including the risk of personal injury.

IN THE INTEREST OF ENVIRONMENT

A muffler which leaks because of rust or damage can permit an increased exhaust noise level. Therefore, examine the muffler(s) periodically to be sure it is functioning effectively. To purchase a new muffler, contact any Briggs & Stratton Authorized Service Center for correct replacement.

CAUTION: SPARK ARRESTER(S) MUST BE ADDED to the muffler(s) of this engine if it is to be used on any forest covered, brush covered, or grass covered unimproved land. The arrester(s) must be maintained in effective working order by the operator. In the State of California the above is required by law (Section 4442 of the California Public Resources Code). Other states may have similar laws. Federal laws apply on federal lands. See your Briggs & Stratton Authorized Service Center or equipment dealer for spark arrester muffler options.

Starting

Start, store and fuel engine in a level position.

DO NOT use a pressurized starting fluid as severe internal damage may occur due to loss of lubrication.

OPEN FUEL VALVE (if so equipped).

CHOKE ENGINE:

 Move engine or equipment choke control lever to "CHOKE" position.

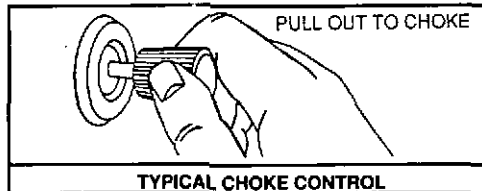

NOTE: Choke should fully close. If it does not, equipment control must be readjusted. See ADJUSTMENT section.

NOTE: A warm engine requires less choking than a cold engine. Engines equipped with a solenoid in the fixed main jet may require choking even when warm.



SET THROTTLE CONTROL LEVER:

Move equipment throttle control lever to "RUN," "FAST" or "START" position, if so equipped.

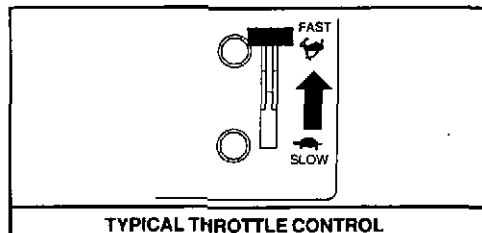

TO START ENGINE:



WARNING: ALWAYS KEEP HANDS AND FEET CLEAR OF MOWER BLADE OR OTHER ROTATING MACHINERY.

ELECTRIC STARTER

Turn key to "START" position or press starter button on powered equipment. The best starter life is provided by using short starting cycles of several seconds. Prolonged cranking (more than 15 seconds per minute) can damage the starter motor. Allow starter to cool two minutes. When engine starts open choke gradually.

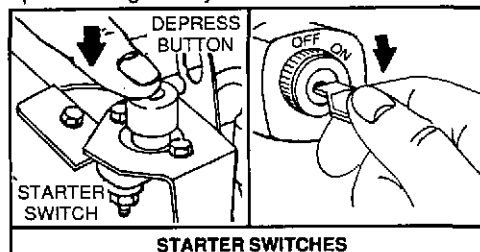

REWIND STARTER



Grasp starter grip as illustrated and pull slowly until resistance is felt. Then pull cord rapidly to overcome compression, prevent kickback and start engine. Repeat if necessary with choke opened slightly. When engine starts, open choke gradually.

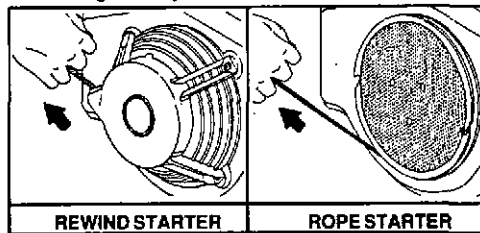

ROPE STARTER



Wind the starter rope around the pulley in the direction shown by arrow. Pull the rope with a quick full arm stroke to prevent kickback. Repeat if necessary with choke opened slightly. When engine starts, open choke gradually.



CAUTION: When using rope starter to crank engine, use caution so knotted end of rope does not strike persons standing nearby.

OIL GARD®

(Optional on engines without oil filter)

If engine is run low on oil, the Oil Gard® will either activate a warning device or stop the engine. Add oil to engine. **FILL TO FULL MARK** on dipstick. Read the operating instructions supplied by the equipment manufacturer to determine which way your engine is equipped.

OIL PRESSURE SWITCH

(Optional on engines with oil filter)

If engine is run low on oil, the pressure switch will either activate a warning device or stop the engine. Add oil to engine. **FILL TO FULL MARK** on dipstick. Read the operating instructions supplied by the equipment manufacturer to determine which way your engine is equipped.

COLD WEATHER STARTING HINTS

1. Use the correct oil for the temperature expected.
2. De-clutch all possible external loads.
3. Set speed control at part throttle position.
4. A warm battery has much more starting capacity than a cold battery.
5. Do not use gasoline left over from summer. Use fresh winter grade fuel which has higher volatility to improve starting.

Stopping

STOP ENGINE:

Move equipment control to "SLOW" and then "STOP" position or engine control to "OFF" position. Turn key to "OFF" position, if so equipped. Do not choke carburetor to stop engine. Fire may result if choke is used to stop engine.

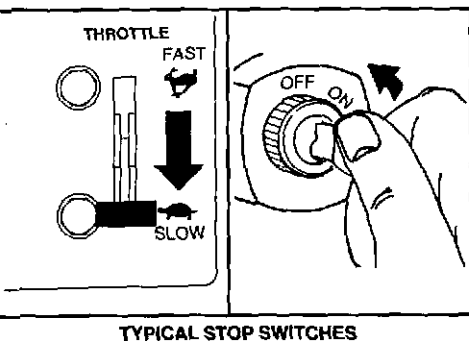

TYPICAL STOP SWITCHES

Always remove key from switch when leaving equipment unattended or when equipment is not in use.

NOTE: Close fuel shut-off valve when engine is transported to prevent fuel leakage from the carburetor.

Adjustments

ENGINE AND EQUIPMENT CONTROLS

Correct control adjustment is necessary for good engine performance.



CAUTION: The manufacturer of the equipment on which the engine is installed specifies the Top No-Load RPM at which the engine will be operated. DO NOT EXCEED this RPM. The acceptable operating range is 1800 to 3600 RPM. Idle speed is 1400 RPM.

TO CHECK OPERATION OF CHOKE CONTROL:

Move equipment choke control to "CHOKE" position. Carburetor choke should be closed.

Move choke control to "CHOKE" position. The carburetor choke should be closed.

TO ADJUST CHOKE CONTROL:

Place control lever on equipment in "CHOKE" position. Loosen casing clamp screw. Move casing and wire until choke is completely closed. Tighten casing clamp screw.

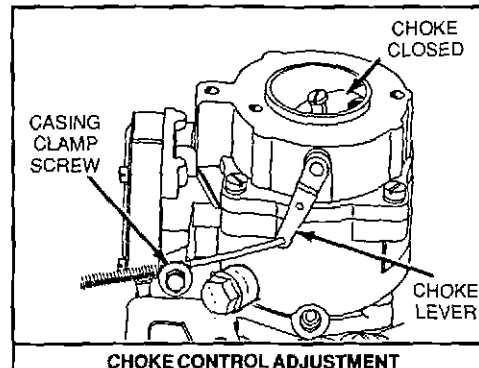

CHOKE CONTROL ADJUSTMENT

TO ADJUST THROTTLE CONTROL:

Engine speed is controlled by movement of the throttle control lever. Move control "B" to "FAST" position. Swivel "C" should be against side of quarter circle. To adjust, loosen casing clamp screw "A." Move casing and wire in direction shown until swivel is against side of quarter circle. Re-tighten casing clamp screw "A."

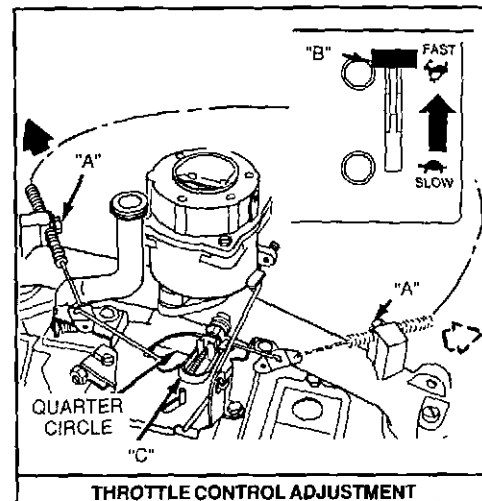

THROTTLE CONTROL ADJUSTMENT

CARBURETOR ADJUSTMENTS

Minor carburetor adjustment may be required to compensate for differences in fuel, temperature, altitude or load. Air cleaner and air cleaner cover must be assembled to carburetor when running engine.

TWIN CYLINDER CARBURETOR ADJUSTMENT IS UNIQUE. ADJUST CARBURETOR FUEL MIXTURE IN THE ORDER STATED AS FOLLOWS.

Adjustments

INITIAL ADJUSTMENT:

Gently turn idle mixture screw clockwise until it just closes. Turning screw in too far may damage it.

Next open the needle valve 1-1/2 turns counterclockwise. This initial adjustment will permit the engine to be started and warmed up (approximately 5 minutes) prior to final adjustment.

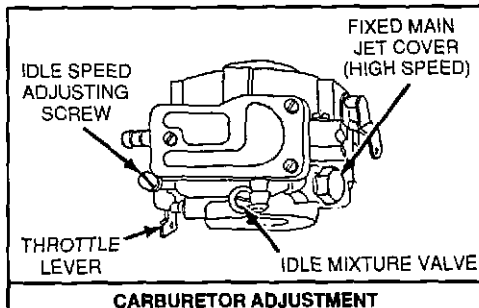

FINAL ADJUSTMENT:

Start engine and place equipment speed control in "IDLE" or "SLOW" position. Hold carburetor throttle lever against idle stop, and adjust idle speed screw to obtain 1200 to 1400 RPM. While still holding throttle lever, turn idle mixture screw slowly clockwise (lean mixture) until speed just starts to slow. Still holding lever, turn screw slowly counterclockwise (rich mixture) until engine speed just starts to slow. Turn screw to midpoint between rich and lean. Adjust idle speed screw to obtain 900 to 1200 RPM. Release lever.

If the engine does not accelerate smoothly, readjust idle mixture screw approximately 1/8 turn counterclockwise (rich).

Maintenance



CAUTION: TO PREVENT ACCIDENTAL STARTING when servicing the engine or equipment, always remove the spark plugs or wires from the spark plugs and insert in holding tab. Disconnect negative wire from battery terminal, if equipped with 12 volt starting system.



CHECK OIL LEVEL REGULARLY:

Check after each 8 hours of operation or daily. BE SURE OIL LEVEL IS MAINTAINED.

CHANGE OIL (engine without oil filter):

Change oil after first 5 hours operation. Thereafter, change oil after every 25 hours of operation or every season, whichever occurs first. Change oil more often if engine is operated under heavy load or at high ambient air temperatures. Remove oil drain plug and drain oil while engine is warm. Replace drain plug. Remove dipstick and refill with new oil of correct grade and weight. Replace dipstick.

CHANGE OIL (engine with oil filter):

Change oil after first five hours of operation. Thereafter, change oil after every 50 hours of operation or every season, whichever occurs first. Change oil more often if engine is operated under heavy load or at high ambient air temperatures. Remove oil drain plug and drain oil while engine is warm. Replace drain plug. Remove dipstick and refill with new oil of correct grade and weight. Replace dipstick.

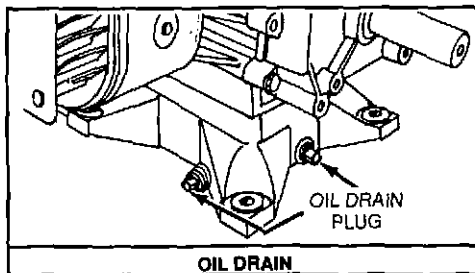

CHANGE OIL FILTER (if so equipped):

Replace oil filter after every 100 hours of operation or every season, whichever occurs first. Before installing new filter, lightly oil filter gasket with fresh clean engine oil. Screw filter on by hand until gasket contacts oil filter adapter. Tighten 1/2 to 3/4 turn more. Start and run engine at idle to check for leaks.

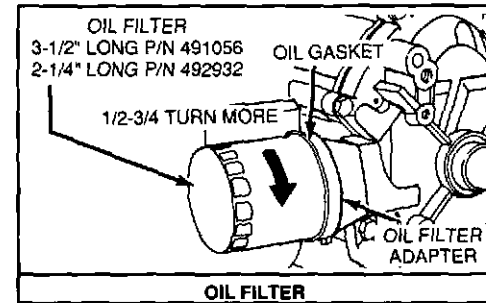

OIL PRESSURE

The normal operating oil pressure for a pressure lube engine (engine with oil filter) is 10 to 50 p.s.i. at normal operating temperature. If pressure drops below the normal range, stop the engine and check oil level with dipstick. If oil level is low, add oil to bring level to FULL mark on dipstick. Restart engine and check oil pressure. If pressure is normal, operation may continue. If oil level is between "ADD" and "FULL" mark on dipstick, DO NOT RESTART ENGINE. Contact your local Briggs & Stratton Service Center. DO NOT OPERATE ENGINE UNTIL OIL PRESSURE IS CORRECTED.

NOTE: Oil pressure gauge is supplied by the Original Equipment Manufacturer.

Maintenance



SERVICE AIR CLEANER:

Remove and service foam pre-cleaner every 25 hours or every season, whichever occurs first.

Service paper cartridge every 100 hours or every season, whichever occurs first.

NOTE: Service air cleaner more often under dusty conditions.

1. Remove knob and air cleaner cover.

To service pre-cleaner:

- a. Remove foam pre-cleaner by sliding it off the cartridge.
- b. Wash pre-cleaner in liquid detergent and water.
- c. Squeeze pre-cleaner dry in a clean cloth.
- d. Saturate pre-cleaner in engine oil. Wrap pre-cleaner in clean, absorbent cloth and squeeze to remove **ALL EXCESS** oil.
- e. Reinstall pre-cleaner over cartridge.
- f. Reinstall air cleaner cover and tighten knob securely.

To service cartridge:

- a. Remove hex nut, washer and cover plate.
- b. Remove cartridge and clean by tapping gently on flat surface.
- c. If very dirty, replace or wash in a non-sudsing detergent and warm water solution. Rinse thoroughly with water from inside out until water runs clear. Let cartridge dry thoroughly before using.



CAUTION: Petroleum solvents, such as kerosene, are not to be used to clean cartridge. They may cause deterioration of the cartridge. **DO NOT OIL CARTRIDGE. DO NOT USE PRESSURIZED AIR TO CLEAN OR DRY CARTRIDGE.**

- e. Reinstall cartridge, cover plate, washer and hex nut.
2. Reinstall air cleaner cover and tighten knob securely.

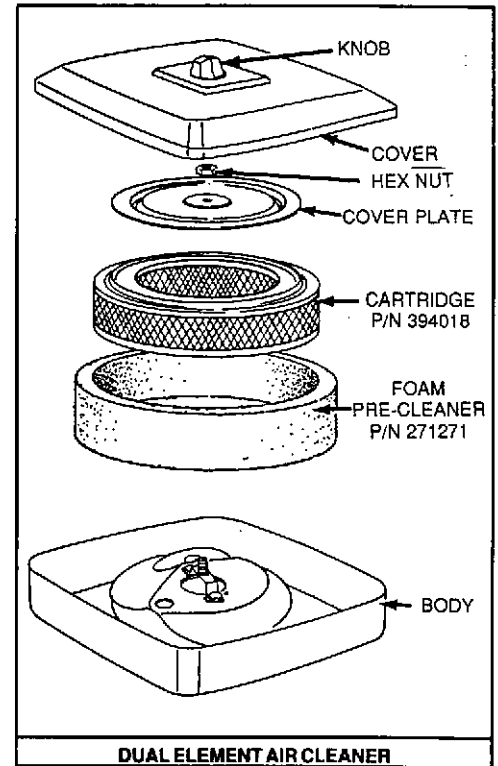

Maintenance

CLEAN ENGINE:

Remove dirt and debris with a cloth or brush. Cleaning with a forceful spray of water is not recommended as water could contaminate the fuel system.

CLEAN DEBRIS GARD:

If engine is equipped with Debris Gard, brush grass, chaff and dirt from gard daily (more often if needed) to prevent engine damage caused by overheating and/or overspeeding.

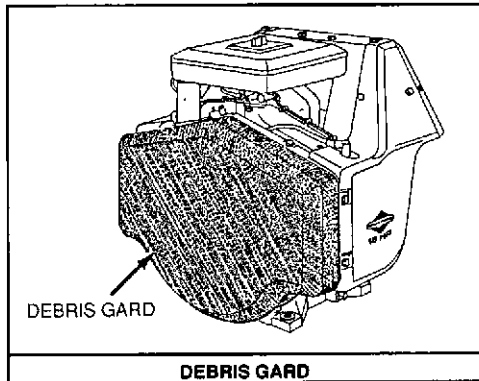

every season, whichever occurs first, remove the blower housing and clean the area shown to prevent overspeeding, overheating and engine damage. Clean more often if necessary.

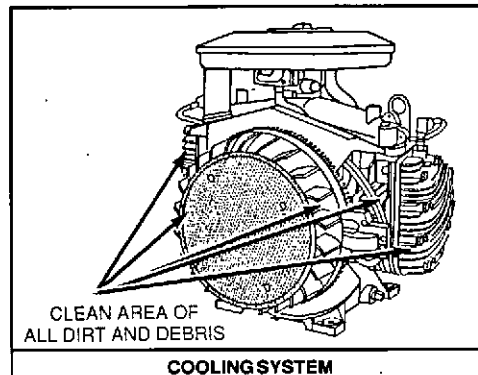

CLEAN SPARK ARRESTER SCREEN(S):

If engine muffler(s) is/are equipped with spark arrester screen assembly(s), remove every 50 hours or every season for cleaning and inspection. Replace if damaged. Contact any Briggs & Stratton Authorized Service Center.

REPLACE OR CLEAN SPARK PLUGS:

Replace or clean every 100 hours of operation or every season, whichever occurs first.

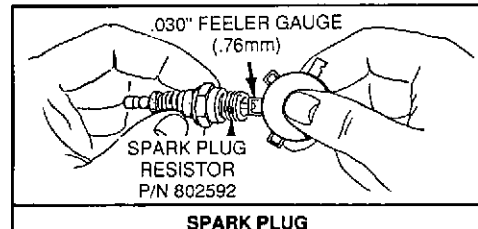

NOTE: Do not blast clean spark plugs. Spark plugs should be cleaned by scraping or wire brushing. Do not wash with a commercial solvent.



CAUTION: Sparking can occur if wire terminal does not fit firmly on spark plug. Reform terminal if necessary.

REPLACE FUEL FILTER:

Replace In-Line filter every season or more often if required. Contact any Briggs & Stratton Authorized Service Center for correct replacement.

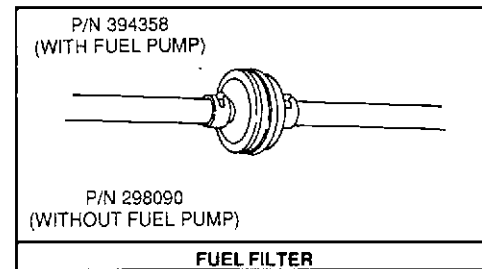

CAUTION: To assure smooth operation, keep governor controls and linkage clean and free of debris.



CAUTION: Periodically clean muffler area to remove all grass, dirt and combustible debris.

CLEAN COOLING SYSTEM:

Grass, chaff or dirt may clog the rotating screen and the air cooling system, especially after prolonged service cutting tall, dry grasses. Every 100 hours or

REMOVE COMBUSTION DEPOSITS:

Remove cylinder heads and cylinder head shields every 100-300 hours of operation. Scrape and wire brush the combustion deposits from cylinder, cylinder heads, top of pistons and around valves. Use a soft brush to remove deposits. Reassemble gaskets, cylinder heads and cylinder head shields. Turn screws down finger tight, with the three longer screws around the exhaust valve, if so equipped. Torque cylinder head screws in a staggered sequence to 165 in.-lbs. (18.65Nm).

Maintenance Schedule







Follow the hourly or calendar intervals, whichever occur first.
More frequent service may be required.

MAINTENANCE OPERATION	Every 8 Hours or Daily	25 Hours or Every Season	50 Hours or Every Season	100 Hours or Every Season	100-300 Hours
Check Oil Level	●				
Change Oil ♦ (Without Oil Filter)		● Note 1			
Change Oil ♦ (With Oil Filter)			● Note 1		
Change Oil Filter				● Note 1	
Service Air Cleaner Pre-Cleaner		● Note 2			
Service Air Cleaner Cartridge				● Note 2	
Debris Gard (Optional Accessory)	● Note 2				
Clean Cooling System				● Note 2	
Inspect Spark Arrester(s) (Optional Accessory)			●		
Replace or Clean Spark Plugs				●	
Replace In-Line Fuel Filter (Optional Accessory)				●	
Clean Combustion Chamber Deposits					●

- ♦ Change oil after first 5 hours, then after every 50 yours or every season.
- Note 1: Change oil more often when operating under heavy load or in high ambient temperatures.
- Note 2: Clean more often under dusty conditions or when airborne debris is present.

**BRIGGS & STRATTON AUTHORIZED SERVICE CENTERS ARE
READY TO SERVE YOU AND ARE COMMITTED TO QUALITY SERVICE.**

International Symbols

-  Air Cleaner
-  Caution
-  Choke
-  Fast
-  Fuel
-  Oil
-  Slow

General Information

This is a twin cylinder, L-head, air-cooled engine. On mobile equipment, the engine will operate satisfactorily at any angle at which operator and equipment can function safely.

MODEL SERIES 400400, 402400, & 404400

Bore	3-7/16 in. (87.31mm)
Stroke	2-5/32 in. (54.77mm)
Displacement	40.00 cu. in. (656.0 cc)
Horsepower	14 HP @ 3600 RPM
Torque (Max.)	24.4 Ft.-Lbs. @ 2300 RPM
Horsepower	16 HP @ 3600 RPM
Torque (Max.)	25.8 Ft.-Lbs. @ 2700 RPM
Horsepower	12.5 HP @ 3600 RPM
Torque (Max.)	23.7 Ft.-Lbs. @ 2200 RPM

MODEL SERIES 422400

Bore	3-7/16 in. (87.31mm)
Stroke	2-9/32 in. (57.94mm)
Displacement	42.33 cu. in. (694.0 cc)
Horsepower	18 HP @ 3600 RPM
Torque (Max.)	28.6 Ft.-Lbs. @ 2600 RPM

The horsepower ratings listed are established in accordance with the Society of Automotive Engineers Test Code J 607. For practical operation, the horsepower loading should not exceed 85% of this rating. Engine power will decrease 3-1/2% for each 1,000 feet (305 m) above sea level and 1% for each 10° above 60° F (16° C).

TUNE-UP SPECIFICATIONS

DESCRIPTION	B & S PART NO.
Air cleaner cartridge	394018
Air cleaner pre-cleaner	271271
Oil Filter (3-1/2 in. long)	491056
Oil Filter (2-1/4 in. long)	492932
Fuel Filter (w/ fuel pump)	394358
Fuel Filter (w/o fuel pump)	298090
Resistor spark plug (Champion RJ19LM)	802592

CLEARANCES	DIMENSION
Spark Plug Gap	.030 in. (.76 mm)
Intake Valve*	.004-.006 in. (.10-.15 mm)
Exhaust Valve*	.007-.009 in. (.18-.23 mm)

* with valve springs installed.

In some areas, local law requires the use of a resistor spark plugs to suppress ignition signals. If an engine was originally equipped with a resistor spark plugs, be sure to use the same type of spark plugs for replacement.

STORAGE INSTRUCTIONS

Engines to be stored over 30 days need to be protected or drained of fuel to prevent gum from forming in the fuel system or on essential carburetor parts.

1. For engine protection, we recommend the use of Briggs & Stratton Gasoline Additive, Part No. 5041, available from any Authorized Briggs & Stratton Service Center. Mix Additive with fuel in fuel tank or storage container. Run engine for a short time to circulate Additive through carburetor. Engine and fuel can be stored up to 24 months.



CAUTION: If Additive is not used or if engine is operating on gasoline containing alcohol, remove all fuel from tank and run engine until it stops from lack of fuel.

2. While engine is still warm, drain oil from crankcase. Refill with fresh oil.
3. Remove spark plugs and pour approximately 1 ounce (30 ml) of engine oil into each cylinder. Replace spark plugs and crank slowly to distribute oil.
4. Clean dirt and chaff from cylinders, cylinder head fins, blower housing, rotating screen and muffler areas.

SERVICE & REPAIR INFORMATION

If service or repair is needed, contact a Briggs & Stratton Authorized Service Center. To serve you promptly and efficiently, the Service Center will need model, type and code numbers on your engine.



Your nearest service center is listed in the "Yellow Pages" under "Engines, Gasoline" or "Gasoline Engines." There are over 25,000 authorized dealers available to serve you.

Each Authorized Service Center carries a stock of Original Briggs & Stratton Service Replacement Parts and is equipped with special service tools. Ask for Original Briggs & Stratton Service Replacement Parts which will preserve the original design of your Briggs & Stratton engine. Imitation replacement parts offer potential risks, not just obvious differences such as, fit, finish and warranty back-up, but hidden differences in internal construction as well. Trained mechanics assure expert repair service on all Briggs & Stratton engines.

Major engine repairs require proper tools and a thorough knowledge of internal combustion engine repair procedure.

Briggs & Stratton publishes illustrated shop manuals, parts lists and owner's manuals for every engine it manufactures. To receive a list of available publications, write to Briggs & Stratton Corporation, P. O. Box 1144, Milwaukee, WI 53201, Attention: Service Division.

The shop manual shown here includes "Theories of Operation," common specifications and detailed information covering adjustment, tune-up and repair of Briggs & Stratton L-head, twin cylinder, 4 cycle engines and is available from a Briggs & Stratton Authorized Service Center. You can also order directly from the factory for \$7.95 (includes postage and handling to U. S. destinations; price subject to change). Send check to the above address and request manual, Part No. 271172.



Part No. 271172

ABOUT THE WARRANTY ON YOUR ENGINE

NOTE: See Back Cover for Statement of Limited Warranty.

If warranty service is needed, contact your nearest Authorized Briggs & Stratton Service Center. For prompt attention, your Center will need to know the engine model, type and code numbers, the trouble experienced and the total number of hours the engine was run.

BRIGGS & STRATTON WARRANTY covers only DEFECTIVE MATERIAL and/or WORKMANSHIP.

Briggs & Stratton Corporation welcomes the opportunity to make justified warranty repairs by any of its Authorized Service Centers. In most instances, the requests for warranty repair are handled in a quick and routine manner. However, some requests for warranty are received which appear not justified. In these cases, though engine owners may not be aware of it, the premature failure of their engine was caused by abuse or neglect, or the equipment on which it was mounted, rather than the engine.

If you differ with the decision of your Service Center, investigation will be made to determine the applicability of warranty. Ask the Service Center to submit all supporting facts to the Factory for review. If the Factory decides that your claim is justified, you will be fully reimbursed for those items accepted as defective. To avoid misunderstanding which might occur between engine owners and Authorized Briggs & Stratton Service Centers, we list below some of the causes of engine failure that Briggs & Stratton warranty does not cover for repair or replacement.

NORMAL WEAR: Engines, like all mechanical devices, need periodic parts service and replacement to perform well. Warranty will not cover repair when normal use has exhausted the life of a part or an engine.

IMPROPER MAINTENANCE: Remember that the service life of an engine depends upon the conditions under which it operates and the care it receives. Some applications, such as tillers, trash pumps and rotary mowers, are very often used in dusty or dirty conditions which can cause what appears to be premature wear. Such wear, when caused by dirt, dust, spark plug cleaning grit or other abrasive material that has entered the engine because of improper maintenance, is not covered by warranty.

WARRANTY DOES NOT APPLY FOR SOME ADJUSTMENTS OR IF ABUSE OR NEGLIGENCE CAUSES ENGINE DAMAGE: SUCH AS

1. Bent or broken crankshafts that could be caused by striking a solid object with the cutter blade of a rotary lawn mower;
2. Sticking valves or clogged carburetors, fuel pipes or other damage caused by using contaminated or stale fuel (Use clean, fresh, lead-free gasoline.);

3. Parts which are scored or broken because an engine was operated with insufficient or contaminated lubricating oil or an incorrect grade of lubricating oil. (4 cycle engines: check oil level daily or after every 8 hours of operation. Refill when necessary and change at recommended intervals.) (2 cycle engines: use correct mixture of gasoline and BIA/NMMA certified oil.);
4. Parts damaged by overspeeding or overheating caused by dirt, grass or debris plugging the cooling fins and clogging the flywheel area; or caused by operating the engine in a confined area without sufficient ventilation (Clean fins on the cylinder, cylinder head and flywheel at recommended intervals.);
5. Damage or wear to parts caused by dirt which entered the engine because of improper air cleaner maintenance or re-assembly (Clean and re-oil the foam pre-cleaner and clean or replace the paper cartridge at recommended intervals.);
6. Damage or wear to parts caused by grit which entered the engine from spark plugs cleaned on an abrasive blast cleaning machine;
7. Tune-up or adjustment needed by an engine but not caused by defective material nor workmanship (Follow the "Operating and Maintenance Instructions" when making any minor adjustments.);
8. Parts broken by excessive vibration caused by loose engine mounting, loose cutter blades, unbalanced blades or impellers, improperly attaching equipment to engine crankshaft, overspeeding or abuse in operation;
9. Repair or adjustment of associated parts or assemblies such as clutches, transmissions, remote controls, etc., which are not of Briggs & Stratton manufacture;
10. PARTS THAT ARE NOT ORIGINAL BRIGGS & STRATTON PARTS OR PARTS THAT ARE NOT APPROVED BY BRIGGS & STRATTON.

Warranty is available only through service centers which have been authorized by the Briggs & Stratton Corporation. Your nearest service center is listed in the Yellow Pages of your Telephone Directory, under "Engines, Gasoline" or "Gasoline Engines."

**Superseding Warranty
BRIGGS & STRATTON ENGINE WARRANTY POLICY
effective July 31, 1989
Replaces all undated previous Warranties and all Warranties
dated before July 31, 1989**

When warranty repair is justified, Briggs & Stratton Corporation welcomes such repair by any of its Authorized Service Centers.

In most instances, the requests for warranty brought to the attention of our Service Accounts are handled in a prompt routine manner with no question regarding their validity. However, some requests for warranty are received which appear not justified. In these cases, engine owners may not be aware that the premature failure of their engine was the result of abuse or neglect, or that the difficulty which they experience is caused by the equipment rather than the engine.

BRIGGS & STRATTON WARRANTY covers only DEFECTIVE MATERIAL and/or WORKMANSHIP.

LIMITED WARRANTY

"For time period shown below from date of purchase, Briggs & Stratton Corporation will replace for the original purchasers, free of charge, any part, or parts of the engine, found upon examination by any Factory Authorized Service Center, or by the Factory at Milwaukee, Wisconsin, to be defective in material or workmanship or both; this is the exclusive remedy. All transportation charges on parts submitted for replacement under this Warranty must be borne by purchaser. For warranty service contact your nearest Authorized Service Center as listed in the 'Yellow Pages' under 'Engines, Gasoline' or 'Gasoline Engines.' THERE IS NO OTHER EXPRESS WARRANTY. IMPLIED WARRANTIES, INCLUDING THOSE OF MERCHANTABILITY AND FITNESS FOR A PARTICULAR PURPOSE ARE LIMITED TO ONE YEAR FROM PURCHASE AND TO THE EXTENT PERMITTED BY LAW ANY AND ALL IMPLIED WARRANTIES ARE EXCLUDED. LIABILITY FOR CONSEQUENTIAL DAMAGES UNDER ANY AND ALL WARRANTIES ARE EXCLUDED TO THE EXTENT EXCLUSION IS PERMITTED BY LAW. Some states do not allow limitations on how long an implied warranty lasts, and some states do not allow the exclusion or limitation of incidental or consequential damages, so the above limitation and exclusion may not apply to you. This warranty gives you specific legal rights and you may also have other rights which vary from state to state."

Briggs & Stratton Corporation
F. P. Stratton, Jr.
Chairman and Chief Executive Officer

WARRANTY PERIOD

ENGINES	CONSUMER USE*	COMMERCIAL USE*
All 2 thru 18 hp engines installed on equipment other than lawn mowers, edgers, tillers, and all Sno Gard engines.	1 year-engine	1 year-engine
All 2 thru 18 hp engines installed on lawn mowers, edgers, tillers, and all Sno Gard engines.	2 year-engine*** 5 year-Magnetron® ignition***	1 year-engine
All Vanguard and I/C® engines	2 year-engine Lifetime** - Magnetron® ignition	2 year-engine Lifetime** - Magnetron® ignition

* For purposes of this warranty policy, "consumer use" shall mean personal residential household use by the original retail consumer. "Commercial use" shall mean all other uses, including use for commercial, income producing or rental purposes. Once an engine has experienced commercial use, it shall thereafter be considered as a commercial use engine for purposes of this warranty policy.

** Lifetime limited warranty of the Magnetron® ignition shall cover parts and labor for the first five (5) years from the date of purchase; thereafter only parts. "Lifetime" shall mean lifetime of the engine in the hands of the original purchaser.

*** Applies to equipment retailed in the U.S.A. and Canada. In all other countries, the warranty for CONSUMER USE is the same as COMMERCIAL USE.

NO REGISTRATION (WARRANTY) CARD IS NECESSARY TO OBTAIN WARRANTY ON BRIGGS & STRATTON ENGINES. SAVE YOUR PURCHASE RECEIPT. PROOF OF PURCHASE DATE WILL BE REQUIRED TO OBTAIN WARRANTY.

BRIGGS & STRATTON ENGINES ARE MADE UNDER ONE OR MORE OF THE FOLLOWING PATENTS:										DESIGN
2,999,491	3,305,223	3,526,146	3,625,492	3,745,393	3,971,353	4,233,043	3,194,224	3,457,804	3,572,218	D-247,177
3,650,354	3,961,724	4,168,288	4,270,509	3,276,439	3,465,740	3,625,071	3,738,345	3,968,854	4,189,040	OTHER PATENTS PENDING