

# Briggs & Stratton

## OPERATING AND MAINTENANCE INSTRUCTIONS

### MODELS

# 100200 to 100292 130200 to 130292

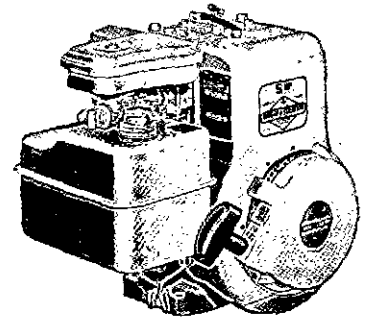

### IN THE INTEREST OF SAFETY, DO NOT RUN ENGINE AT EXCESSIVE SPEEDS

Operating an engine at excessive speeds increases the hazard of personal injury. **DO NOT TAMPER WITH PARTS WHICH MAY INCREASE THE GOVERNED SPEED.**

For rotary lawnmower safety, USA Standard Safety Specifications for Power Lawn Mowers specify a maximum blade tip speed of 19,000 feet per minute, primarily to reduce the hazard from thrown objects.

Rotary lawnmower manufacturers select the governed top speed of the engine based on the length and design of the cutter blade and design of other mower parts.

All rotary lawnmowers should be checked for conformance to the USA Standard Safety Specifications for Power Lawn Mowers on blade tip speed, if the engine is repaired or replaced, or if mower parts are changed.

Dirt and grass clippings, or other debris, in cooling fins or governor parts can affect engine speed. See cleaning instructions in Section 3.

### CAUTION

TO PREVENT ACCIDENTAL STARTING always remove the spark plug before working on the engine or equipment driven by the engine or remove cable from spark plug and insert terminal in V-notch in cylinder head cover.

DO NOT RUN THE ENGINE IN AN ENCLOSED AREA. Exhaust gases contain carbon monoxide, an odorless and deadly poison. DO NOT FILL GASOLINE TANK WHILE ENGINE IS RUNNING. Spilling gasoline on a hot engine may cause a fire or explosion.

## Section 1 BEFORE STARTING

READ THE OPERATING INSTRUCTIONS OF THE EQUIPMENT THIS ENGINE POWERS

- ① **FILL CRANKCASE WITH OIL** — Use a high quality detergent oil classified "For Service SC, SD, SE or MS". Nothing should be added to the recommended oil.

**SUMMER**  
(Above 40° F.)  
Use SAE 30

If not available,  
Use SAE 10W-30  
or  
SAE 10W-40

**WINTER**  
(Under 40° F.)  
Use SAE 5W-20 or SAE 5W-30

If not available,  
Use SAE 10W or SAE 10W-30

Below 0° F.,  
Use SAE 10W or SAE 10W-30  
Diluted 10% with Kerosene

**DIRECTIONS:** Place the engine level. Remove oil filler plug or Oil-Minder. FILL THE OIL SUMP TO OVERFLOWING or to the FULL mark on dipstick. Pour slowly. Capacity 1-1/4 pints.

- ② **FILL FUEL TANK** — Use clean, fresh, lead-free or leaded "regular" grade automotive gasoline. Fill tank completely!

DO NOT MIX OIL WITH GASOLINE.

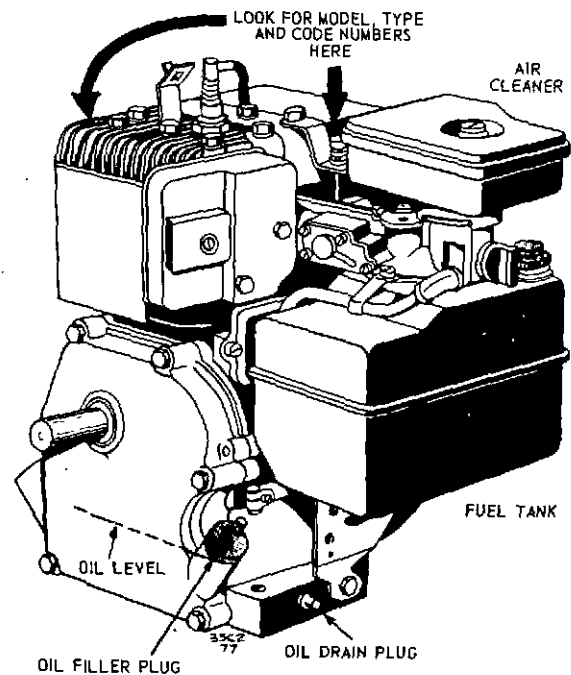

① **CHOKE ENGINE** – Engine may be equipped with either Manual, Choke-A-Matic or Lever-Trol controls.

a. **Manual Choke and Stop** – Be sure stop switch is away from spark plug. Pull choke as illustrated.

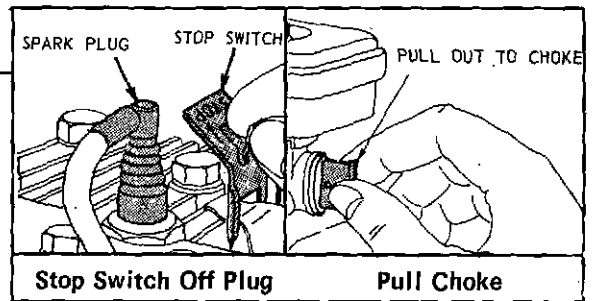

b. **Choke-A-Matic and Lever-Trol** – Move controls as far as possible toward "Choke" or "Start".

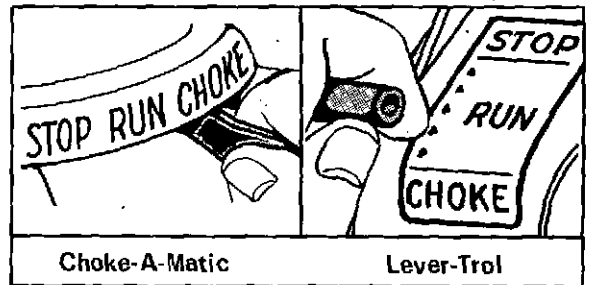

② **START ENGINE** – Grasp starter handle as illustrated and pull out cord rapidly. Repeat if necessary with choke opened slightly. When engine starts open choke gradually.

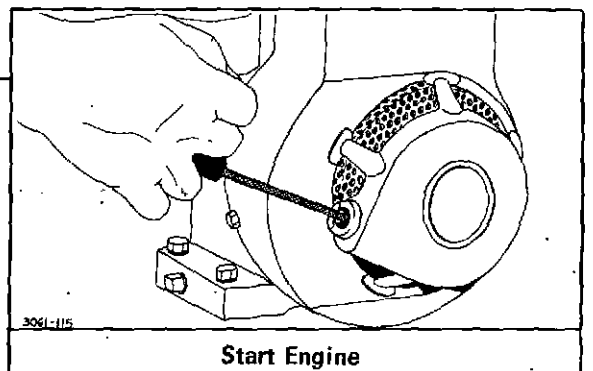

**NOTE:** Engine may not start if controls on powered equipment do not close choke fully. See Choke-A-Matic adjustment instructions in Section 4 of this manual if controls on equipment do not fully close choke as illustrated below.

**CAUTION:** ALWAYS KEEP HANDS AND FEET CLEAR OF MOWER BLADE OR OTHER ROTATING MACHINERY.

③ **STOP ENGINE**

**MANUAL STOP SWITCH**

Push the stop switch against end of spark plug.

**REMOTE STOP SWITCH**

Move control lever to "Stop" position.

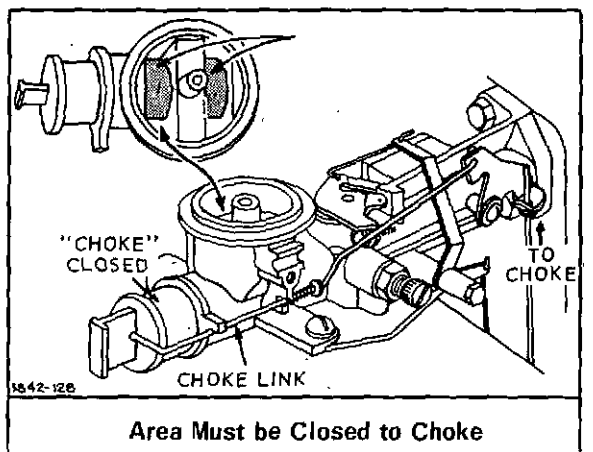

- 1 **CHECK OIL LEVEL** regularly — at least after each 5 hours of operation. (Take care to remove dirt around filler plug). Be sure oil level is maintained FULL TO POINT OF OVERFLOWING.

**CHECK OIL (6 to 1 Gear Reduction Models Optional)** every 100 hours by removing the oil plug in lower half of gear cover. Add SAE 10W-30 oil at upper oil filler plug until oil runs out of lower hole. Replace both plugs.

**NOTE:** Filler plug has vent hole and must be placed in top opening.

- 2 **CHANGE OIL** after first 5 hours of operation. Thereafter change oil every 25 hours of operation. Remove drain plug and drain oil while engine is warm. Replace drain plug. Remove oil filler cap and refill with new oil of proper grade. Replace filler cap.

- 3 **CLEAN AIR CLEANER AND RE-OIL ELEMENT** every 25 hours under normal conditions. The capacity of the "Oil-Foam" air cleaner is adequate for a full season's use without cleaning in average homeowner lawn mower service. (Clean every few hours under extremely dusty conditions):

1. Remove screw.
2. Remove air cleaner carefully to prevent dirt from entering carburetor.
3. Take air cleaner apart.
4. A — Wash foam element in kerosene or liquid detergent and water to remove dirt.
- B — Wrap foam in cloth and squeeze dry.
- C — Saturate foam in engine oil. Squeeze to remove excess oil.
- D — Assemble parts - fasten to carburetor with screw.

- 4 **CLEAN COOLING SYSTEM** — Grass or chaff may clog cooling system after prolonged service in cutting tall dry grasses or hay. Continued operation with a clogged cooling system causes severe overheating and possible engine damage. Remove blower housing and clean regularly.

- 5 **SPARK PLUG** — Clean and reset gap at .030" every 100 hours of operation.

- 6 **REMOVE CARBON DEPOSITS** — Clean combustion chamber, top of piston and around both valves every 100-200 hours of operation.

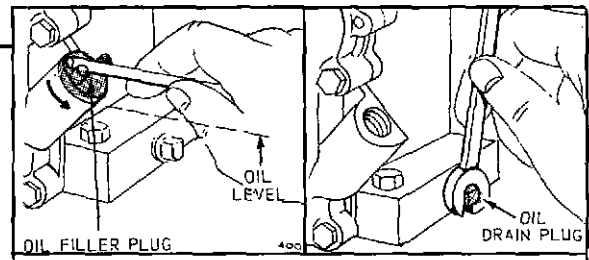

Check Oil Level

Change Oil

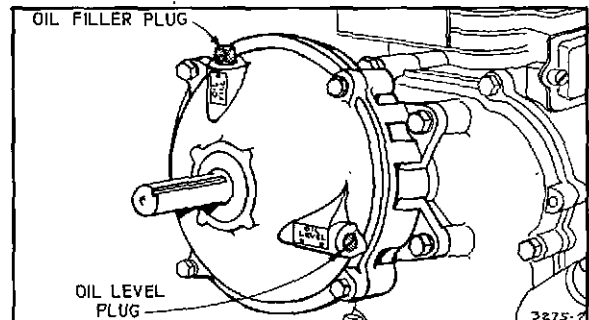

Check Oil (6 to 1 Gear Reduction Models)

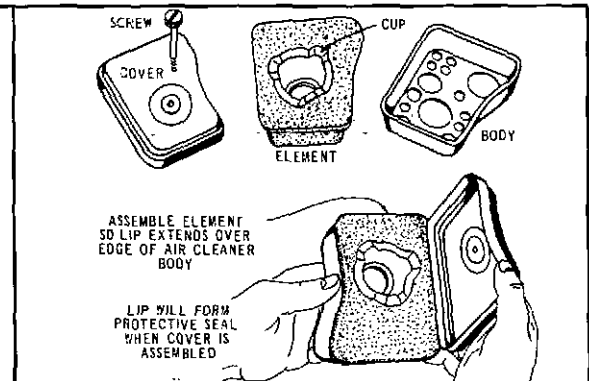

Clean Air Cleaner

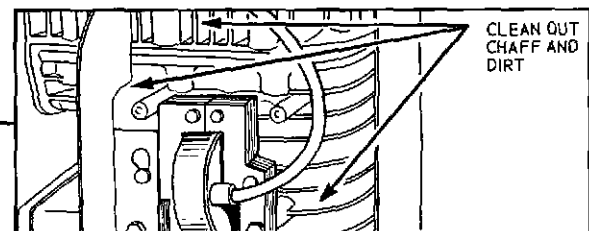

Clean Cooling System

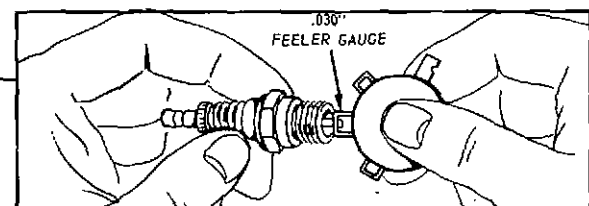

Clean and Reset Spark Plug

Section  
6

# SERVICE & REPAIR INFORMATION

If service or repair is needed, contact an Authorized Briggs & Stratton Service Center. To serve you promptly and efficiently, the Service Center will need the model, type and code number on your engine. (See Section 7).

Each Authorized Service Center carries a stock of original Briggs & Stratton repair parts and is equipped with special service tools. Trained mechanics assure expert repair service on all Briggs & Stratton engines.

Your nearest service center is listed in the 'Yellow Pages' under "Engines, Gasoline" or "Gasoline Engines". He is one of over 15,000 service centers available to serve you.



FOR REPAIRS AND SERVICE CONTACT  
THE DEALER DISPLAYING THIS SIGN



Section  
7

# WARRANTY

SAVE THIS SECTION FOR YOUR RECORD

## BRIGGS & STRATTON ENGINE WARRANTY

For ONE YEAR from purchase date, Briggs & Stratton Corp. will replace for the original purchaser, FREE OF CHARGE, any part, or parts, found upon examination by any Factory Authorized Service Center, or by the Factory at Milwaukee, Wisconsin, to be DEFECTIVE IN MATERIAL AND/OR WORKMANSHIP.

All transportation charges on parts submitted for replacement under this Warranty must be borne by purchaser.

*There is no other Warranty express or implied. Briggs & Stratton Corp. shall in no event be liable for consequential damages.*

BRIGGS & STRATTON CORP.

*V. R. Shieley*

V. R. SHIELEY - PRESIDENT

NOTE: The Briggs & Stratton Engine Warranty does not cover breakage of parts or damage to parts due to abuse or failure to follow the recommended maintenance procedures. The warranty also excludes any accessories, controls or equipment which are not manufactured by Briggs & Stratton Corporation.

If warranty service is needed contact your nearest Authorized Service Center. For Prompt Attention your center will need to know the engine model, type and code number, the trouble experienced and the total number of hours the engine has run. If you differ with the decision of a Service Center on a warranty claim, ask the Service Center to submit all supporting facts to the Factory for review. If the Factory decides that your claim is justified, you will be fully reimbursed for those items accepted as defective.

FILL IN THE REQUIRED INFORMATION: (See Decal on Blower Housing for Model, Type and Code Number)

Engine Model No. \_\_\_\_\_ Type No. \_\_\_\_\_ Code No. \_\_\_\_\_

Dealer Purchased From \_\_\_\_\_ Date \_\_\_\_\_

Type of Equipment \_\_\_\_\_

Name or Trademark of Equipment Manufacturer \_\_\_\_\_

BRIGGS & STRATTON ENGINES ARE MADE UNDER ONE OR MORE OF THE FOLLOWING PATENTS:

|           |           |           |           |           |           |   |
|-----------|-----------|-----------|-----------|-----------|-----------|---|
| 2,669,322 | 2,796,453 | 3,114,851 | 3,149,618 | 3,194,224 | 3,252,449 | DESIGN                                  |
| 2,693,789 | 2,999,491 | 3,118,433 | 3,165,094 | 3,236,937 | 3,276,439 | D-191,806 D-196,017 D-197,175 D-213,476 |
| 2,693,791 | 2,999,562 | 3,144,087 | 3,168,936 | 3,242,741 | 3,378,099 | OTHER PATENTS PENDING                   |
|           |           |           |           |           | 3,415,237 |   |

## CARBURETOR ADJUSTMENTS

Minor carburetor adjustment may be required to compensate for differences in fuel, temperature, altitude and load.

**Initial Adjustment:** Close needle valve (turn clockwise), then open 1-1/2 turns (turn counterclockwise). This initial adjustment will permit the engine to be started and warmed up before making final adjustment.

**Final Adjustment:** With engine running at normal operating speed (approximately 3000 RPM without load) close the needle valve (turn clockwise) until engine starts to lose speed (lean mixture). Then slowly open needle valve (turn counterclockwise), past the point of smoothest operation, until engine just begins to run unevenly. This mixture should be rich enough for best performance under load. Hold throttle in idling position. Turn idle speed adjusting screw until fast idle is obtained (1750 RPM). Test the engine under full load. If engine tends to stall or die out, it usually indicates that the mixture is slightly lean and it may be necessary to open the needle valve slightly to provide a richer mixture. This richer mixture may cause a slight unevenness in idling.

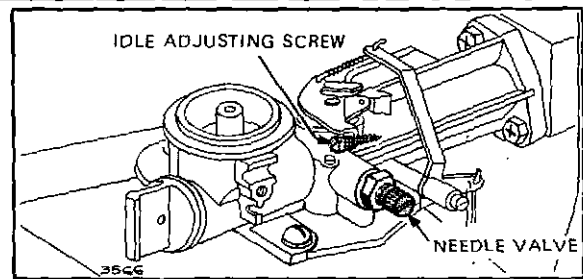

## REMOTE CHOKE AND STOP CONTROL ADJUSTMENTS

Proper choke and stop switch operation is dependent upon proper adjustment of remote controls on the powered equipment.

### To Check Operation:

Remove air cleaner. Move remote control lever to CHOKE POSITION. The choke knob should then be fully extended. Move remote control lever to STOP. Governor control lever on fuel tank bracket should make good contact with stop switch to short out ignition.

### To Adjust:

Place remote control lever on equipment in FAST position. Choke operating link "A" should be just touching bell crank lever at "B". See illustration.

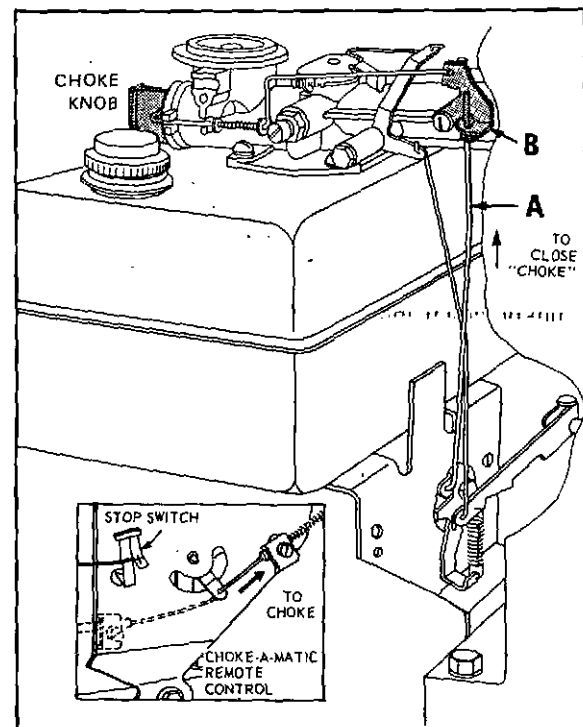

## STANDARD SPEED CONTROL ADJUSTMENT

Speed adjusting thumb nut is located on top of engine. To increase speed turn thumb nut clockwise.

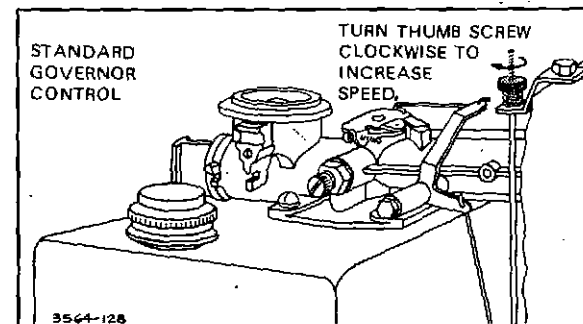

## REMOTE SPEED CONTROL

Controls on powered equipment should move speed lever in direction illustrated above to increase speed. Remote controls may be connected to engine at three points indicated. Wire travel is shown by arrows.

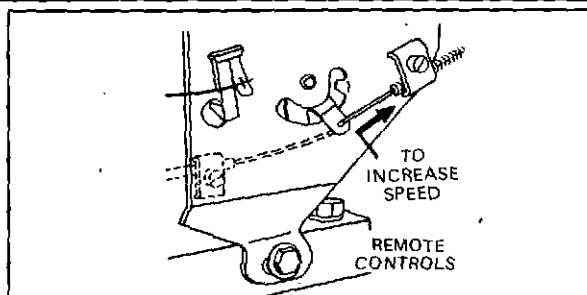

## MANUAL SPEED CONTROL

Move knob as shown to change engine speed.

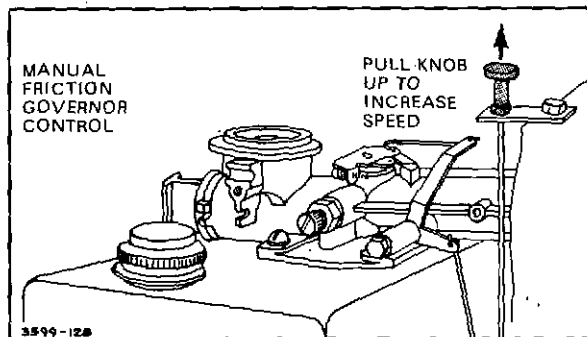

**ENGINE DESIGN** — Your engine is 4 cycle, single cylinder and L-head. It is air cooled.

### MODEL SERIES 100200 to 100292

|                   |                      |
|-------------------|----------------------|
| Bore              | 2 1/2"               |
| Stroke            | 2 1/8"               |
| Displacement      | 10.43 cu. in.        |
| Horsepower        | 4.0 max. @ 3600 RPM  |
| Torque (Ft. Lbs.) | 5.93 max. @ 3050 RPM |

### MODEL SERIES 130200 to 130292

|                   |                      |
|-------------------|----------------------|
| Bore              | 2 9/16"              |
| Stroke            | 2 7/16"              |
| Displacement      | 12.57 cu. in.        |
| Horsepower        | 5.0 max. @ 3600 RPM  |
| Torque (Ft. Lbs.) | 7.66 max. @ 3000 RPM |

The horsepower ratings listed above are established in accordance with the Society of Automotive Engineers Test Code-J607. For practical operation, the horsepower loading should not exceed 85% of these ratings. Engine power will decrease 3½% for each 1,000 feet above sea level and 1% for each 10° above 60° F.

Major engine repairs should not be attempted unless you have the proper tools and a thorough knowledge of internal combustion engines.

## TUNE-UP SPECIFICATIONS

| Spark Plug Type         | A.C.          | Autolite | Champion |
|-------------------------|---------------|----------|----------|
| Short Plug              | CS-45         | A7N      | CJ-8     |
| Long Plug               | GC-46         | A7Q      | J-8      |
| Spark Plug Gap          | .030"         |          |          |
| Ignition Point Gap      | .020"         |          |          |
| Intake Valve Clearance  | .005" - .007" |          |          |
| Exhaust Valve Clearance | .009" - .011" |          |          |

## STORAGE INSTRUCTIONS

Engines to be stored over 30 days should be completely drained of fuel to prevent gum deposits forming on essential carburetor parts, and tank.

- All fuel should be removed from fuel tank. Run the engine until it stops from lack of fuel. The small amount of fuel that remains in the sump of the tank should then be removed by absorbing it with a clean dry cloth.
- Remove spark plug, pour 1 ounce (2 or 3 tablespoons) of SAE-30 oil into cylinder and crank slowly to distribute oil. Replace spark plug.
- Clean dirt and chaff from cylinder, cylinder head fins and blower housing.