



MODEL SERIES
23C, 23C-B,
23C-FB, 23C-R6

OPERATING AND MAINTENANCE INSTRUCTIONS

IMPORTANT:

Do not start this engine before reading Section I and Section II of this manual. It takes only a few minutes.

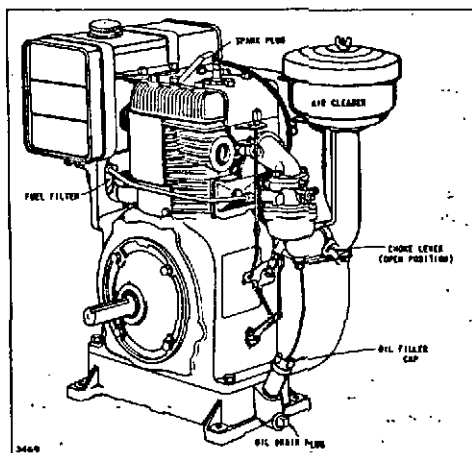

CAUTION

1. PROVIDE EFFICIENT VENTILATION. Exhaust gases contain carbon monoxide which is odorless and a deadly poison. Proper care must be taken to provide efficient ventilation.
2. DO NOT FILL GASOLINE TANK WHILE ENGINE IS RUNNING. Avoid spilling gasoline on a hot engine — this may cause an explosion and serious injury.
3. KEEP ENGINE CLEAN. This engine is air-cooled. If cooling system becomes clogged, serious damage may result. Therefore, keep the blower screen, fins on flywheel, cylinder and cylinder head free from grass or dirt.
4. Be sure nobody is behind you when starting engine with rope starter.

SECTION I

BEFORE STARTING

FILL CRANKCASE WITH OIL

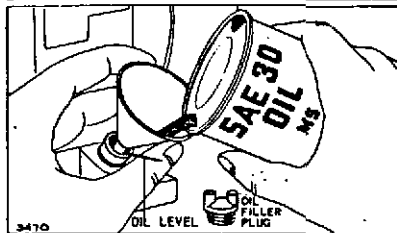
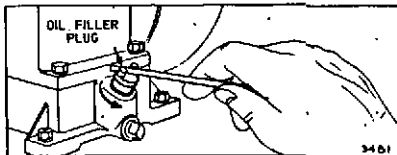

The oil filler cap is located at the end of engine base. To open, use a screwdriver or bar as illustrated. With the engine standing level pour oil in opening until it rises to the top of filler cap opening. Be sure oil stays at top level before replacing cap. Oil capacity is 4 pints.

High quality engine oils bearing the American Petroleum Institute classification "For Service MS" should be used in your Briggs & Stratton engine. Detergent oils keep the engine cleaner and retard the formation of gum and varnish deposits.

ABOVE 32°F
Use SAE-30

BELOW 32°F
Use SAE-10W

Nothing should be added to the recommended oils.

Air Cleaner protects engine from grit and dirt. Use the same oil as in the crankcase. Remove wing nut. Lift out filter element. Lift off bowl. Pour oil in small bottom part of bowl to "oil level" mark at end of arrows. Replace bowl, element, and wing nut. Be sure gaskets are in place.

PUT OIL IN AIR CLEANER

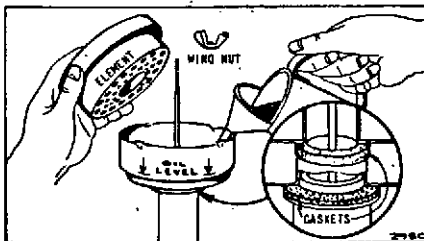

FILL FUEL TANK COMPLETELY

CAUTION: Use clean, fresh "regular" grade gasoline. Purchase fuel in small quantities and keep in clean container. Prolonged storage of gasoline can result in the formation of gum deposits which clog the fuel system.

DO NOT MIX OIL WITH GASOLINE.

SECTION II STARTING AND STOPPING

TO START ENGINE

1. Open Fuel Valve

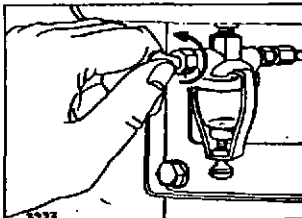

2. Close the Choke

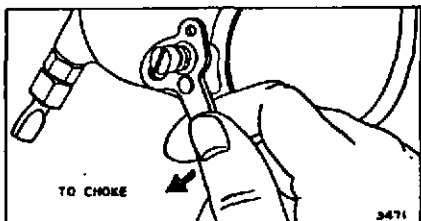

3. Start Engine

a. Rope Starter

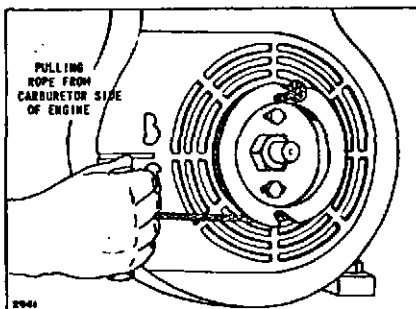

Place knot in pulley notch and wind rope around pulley in a clockwise direction. Pull rope with choke closed to prime the engine. Open choke slightly and repeat operation.

After engine warms up open choke gradually until engine runs smoothly with choke wide open (counterclockwise position).

b. 12-volt D.C. Electric Starter

Press starter button on powered equipment. When engine starts open choke gradually.

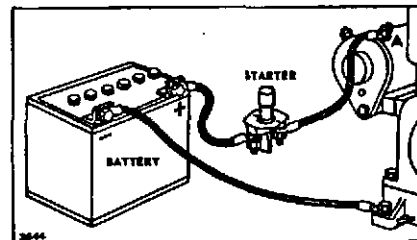

TO STOP ENGINE

Push the stop switch against end of spark plug.

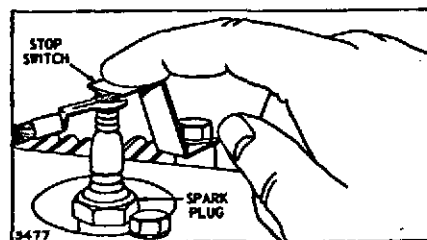

SECTION III REGULAR MAINTENANCE

SERVICE AIR CLEANER REGULARLY

Clean and re-oil the air cleaner frequently (every few hours under extremely dusty conditions). Clean and re-oil at least every 25 hours under normal conditions.

Oil Bath Type

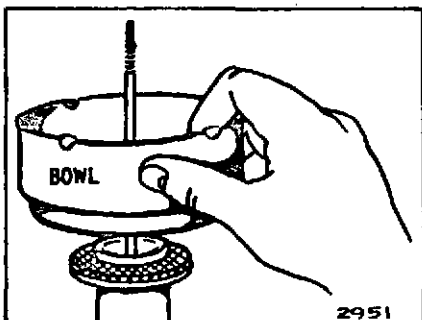

Remove wing nut, lift out upper element and remove bowl containing oil.

Pour out old oil. Wash the filter element in kerosene or gasoline and shake dry. Clean bowl, wipe dry. Pour oil in small bottom part of bowl to "oil level" mark shown at end of arrows. Replace bowl. Replace filter element and wing nut. Be sure gaskets are in place.

SERVICING "OIL-FOAM" AIR CLEANER

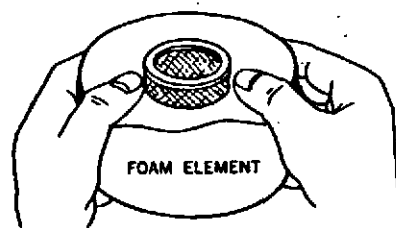
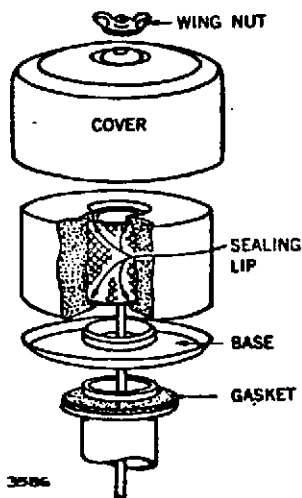

1. Remove wing nut and cover.
2. Lift off foam element from base.
3. Push down foam element as shown and pull out screen.

4. A — Wash foam element in kerosene or solvent.
B — Squeeze dry and reoil with 6 tablespoons engine oil.
C — Squeeze again to spread oil through foam element.
D — Put screen inside element. Be sure sealing lip is over end of screen (top and bottom).
5. Reassemble parts as shown. Fasten to engine. Screw wing nut down tight.

*Trademark of Briggs & Stratton Corp.

SECTION III — REGULAR MAINTENANCE (Cont'd)

CHANGE OIL (Crankcase)

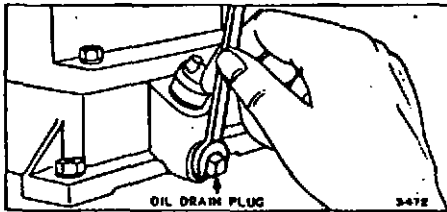

Change oil after 5 hours of operation. Remove the oil drain plug. Drain oil while the engine is warm. Replace drain plug. Remove oil filler cap or plug and refill with new oil. Replace oil filler cap or plug. Add oil regularly after each 5 hours of operation. Thereafter change oil every 25 hours of operation.

CHANGE OIL (Gear Reduction)

The reduction gears are lubricated by engine crankcase oil. Remove drain plug from gear case cover to drain oil remaining in gear case when crankcase oil is changed.

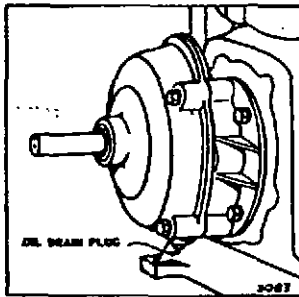

CLEAN COMBUSTION CHAMBER EVERY 100-300 HOURS OF OPERATION

This industrial engine generally operates at constant speed and at relatively constant load. The use of regular auto-

motive fuels under these conditions results in a gradual build-up of tetraethyl lead deposits in the combustion chamber. This causes the engine to lose power and prevents the valves from seating properly. Removing the deposits is easy and will pay big dividends in reliability and increased valve life.

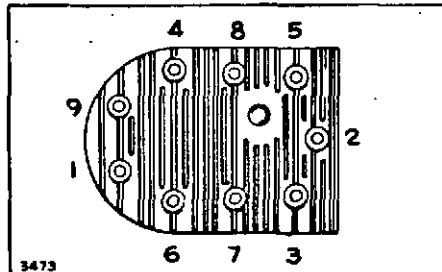

CYLINDER HEAD — COMBUSTION CHAMBER CLEAN-OUT

1. Remove cylinder head screws. Be sure to note if screws are of different length and have steel washers as they must be replaced in original position.
2. Turn crankshaft until piston is at top of cylinder bore and both valves are closed. Scrape and wire brush the lead and carbon deposits from cylinder head and combustion chamber.
3. Re-use cylinder head gasket only if in good condition. Replace cylinder head. Turn each screw in with wrench until screw head is lightly seated.
4. Use socket wrench with 6" handle and turn all screws $\frac{1}{4}$ turn. Tighten screws in sequence illustrated. Run engine approximately 5 minutes and retighten all screws approximately $\frac{1}{4}$ turn.

DRAINING FUEL TANK AND CLEANING FUEL FILTER

Loosen thumb screw below filter bowl.

Remove and clean filter bowl and screen.

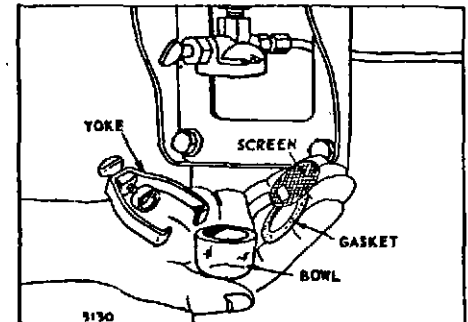

Open shut-off valve to see if fuel flows freely from the tank. **IMPORTANT:** If you find a gummy, varnish-like substance use alcohol or acetone to dissolve it.

STORAGE INSTRUCTIONS

Engines stored for over 30 days should be completely drained of fuel to prevent gum deposits forming on essential carburetor parts, fuel filter, fuel lines and tank.

- a. Remove filter bowl, open shut-off valve and drain tank completely.
- b. Replace filter bowl. Leave fuel valve open.
- c. Operate engine until it stops from lack of fuel.
- d. While engine is still warm drain and clean the oil sump. Refill with fresh oil.
- e. Remove spark plug, pour one ounce of S.A.E. 30 oil into cylinder and crank slowly to spread oil. Replace spark plug.
- f. Clean dirt and chaff from cylinder, cylinder head fins and blower housing.

SECTION IV ADJUSTMENTS

CARBURETOR ADJUSTMENTS

Initial Adjustment

Turn needle valve clockwise until it just closes. **CAUTION:** Valve may be damaged by turning it in too far.

Now open needle valve $1\frac{1}{2}$ turns counterclockwise.

Close idle valve in same manner and open it $\frac{1}{2}$ to $\frac{3}{4}$ turns. This initial adjustment will permit the engine to be started and warmed up prior to final adjustment.

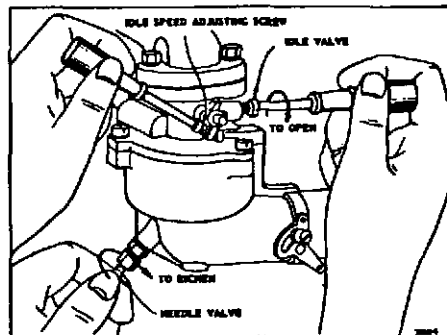

Final Adjustment

Turn needle valve in until engine misses (lean mixture), then turn it out past smooth operating point until engine runs unevenly (rich mixture). Now turn needle valve to the mid-point between rich and lean so the engine runs smoothly.

Hold throttle at idle position, set idle speed adjusting screw until fast idle is obtained (1200 R.P.M.). Hold throttle in idle position and turn idle valve in

SECTION IV — ADJUSTMENTS (Cont'd)

(lean) and out (rich) until engine idles smoothly. Then reset idle speed so that engine idles at 1200 R.P.M. Release throttle — engine should accelerate without hesitation or sputtering. If engine does not accelerate properly, re-adjust carburetor to a slightly richer mixture.

GOVERNOR ADJUSTMENTS

The correct operating speed range is 1800 to 3600 R.P.M. The standard speed setting (no load) is 2900 R.P.M. Idle speed is 1200 R.P.M.

Thumb Nut Adjustment

To increase speed, turn nut (clockwise) or move lower end of governor spring farther away from governor lever shaft.

To reduce speed, turn nut (counter-clockwise) or move lower end of spring closer to governor lever shaft.

If the speed variation between no load and full load is too great move spring closer to governor lever shaft.

If the speed of the engine is not steady although the carburetor has been properly adjusted, move the spring farther away from the governor lever shaft.

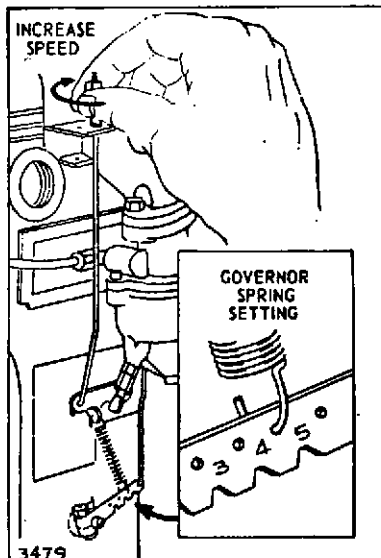

REMOTE GOVERNOR CONTROL

If engine is equipped with a remote governor control, check illustrations above, and adjust as follows: Move control lever to HIGH speed position.

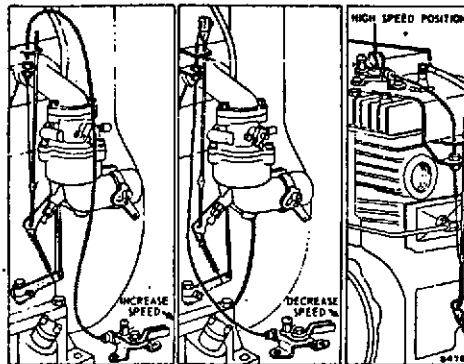

Loosen screw on swivel. Move wire through swivel until desired operating speed is obtained. Retighten swivel screw, bend loose end of wire around swivel. Cut off excess wire. Be sure to remove or loosen thumb screw on governor control rod.

ADJUSTMENT AND CLEANING OF CONTACT POINTS

Rope, starter pulley, blower housing, flywheel, and magneto point dust cover must be removed.

1. TO REMOVE FLYWHEEL

Take 2 screws off rope starter pulley. Remove blower housing. Place a block of wood under flywheel fin on the left side, close to the flywheel to hold it securely. Use a large wrench, turn to left to loosen. Crankshaft has right hand thread.

2. TO REMOVE FLYWHEEL with FLYWHEEL PULLER

Remove nut and fasten puller No. 19068 to flywheel with two screws provided. Turn down the two screws evenly until flywheel is loosened. Pull off flywheel. Save key.

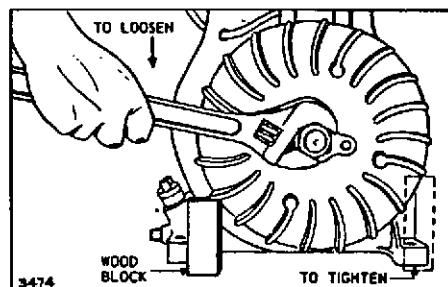
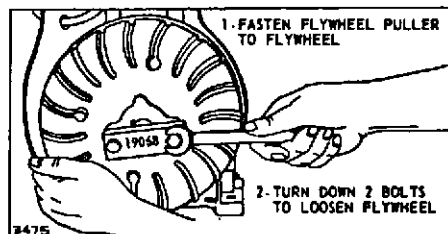

3. TO ADJUST AND CLEAN CONTACT POINTS.

Remove dust cover. Points must be clean and line up squarely to make good contact. Do not file points — use fine sandpaper or a hone to dress the points. Turn the crankshaft until points open to widest gap. Loosen contact bracket screw slightly, using a screwdriver in slot as shown. Move bracket up or down to obtain .018" gap. After correct gap is obtained tighten bracket screw securely.

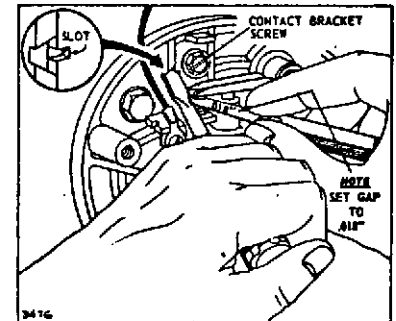

If either or both points become badly pitted or burned, replace with complete new Contact Point Assembly. Replace dust cover.

4. TO REASSEMBLE FLYWHEEL

Clean flywheel hole and tapered end of crankshaft. Turn keyway of crankshaft up. Put flywheel on shaft and align keyways. Insert key into keyways and push securely into place. (If key is partially sheared or damaged, replace with a new key, No. 61760.). This is a soft key. DO NOT USE STEEL KEY. Put on nut. Place a wood block under fin on right side of flywheel. Tighten nut to 130-140 ft. lbs. of torque. Replace blower housing and rope starter pulley.

TO CHECK SPARK PLUG GAP

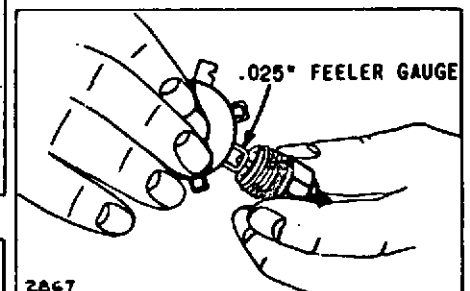

Clean spark plug and reset gap at .025" every 100 hours of operation. When worn out replace with: AC 45 Comm., Autolite A7R or Champion J-8. Size 14 mm.

SECTION V
PARTS AND SERVICE

NATION WIDE SERVICE ORGANIZATION

Briggs & Stratton maintains a vast network of Authorized Service Dealers that are prepared to give you prompt and efficient engine service.

Each member of this organization carries a stock of original Briggs & Stratton repair parts and is equipped with special service tools.

An illustrated parts list is available from any Briggs & Stratton authorized service organization.



See yellow pages of your Classified Telephone Directory for nearby engine service under heading "Engines - Gasoline" or "Gasoline Engines".

BRIGGS & STRATTON ENGINE WARRANTY POLICY

Here is a reproduction of the Briggs & Stratton Warranty that is supplied with each engine. (Be sure to fill out and return registration card at time of purchase).

THE WARRANTY

For **ONE YEAR** from purchase date, Briggs & Stratton Corp., will replace for the original purchaser **FREE OF CHARGE**, any part, or parts, found upon examination by any Factory Authorized Service Outlet, or by the Factory at Milwaukee, Wisconsin, to be **DEFECTIVE IN MATERIAL AND/OR WORKMANSHIP**.

All transportation charges on parts submitted for replacement under this warranty must be borne by purchaser.

There is no other Warranty express or implied, Briggs & Stratton Corp. shall in no event be liable for consequential damages.

WARRANTY DOES NOT COVER BENT CRANKSHAFTS, FAILURE TO MAINTAIN OIL IN CRANKCASE, USER NEGLIGENCE OR ABUSE

WARRANTY INSTRUCTIONS

When you request engine or parts warranty service, always supply the Briggs & Stratton Authorized Service Dealer the following information:

Model Number, Type Number and Serial Number that are stamped on engine blower housing.

Date Purchased.

Kind of equipment engine is used on.

Name or trademark of manufacturer.

Name and address of dealer from whom purchased.

Approximate number of hours engine has run since equipment was purchased.

Also, give complete report of trouble experienced and special servicing instructions.

If you differ with the decision of a Service Dealer on a warranty claim, the Dealer's terms should be accepted. The Dealer will submit all supporting facts to the factory for review. If the factory's decision is that your claim is justified, you will be fully reimbursed for those items accepted as defective.

GENERAL INFORMATION

This engine is a single cylinder, L-Head air-cooled type; bore 3" and stroke 3¼". It is rated at:

5.27 h.p. at 1800 r.p.m.

8.63 h.p. at 3000 r.p.m.

7.21 h.p. at 2400 r.p.m.

9.00 h.p. at 3600 r.p.m.

Torque (Ft.-Lbs.) .15.75 at 2400 RPM

Intake Valve Clearance007"-009"

Exhaust Valve Clearance . . .017"-019"

The horsepower ratings listed above are established by standard I.C.E.I. procedures. For practical operation, the horsepower loading should not exceed 85 percent of these ratings. Engine power will decrease 3½ percent for each 1,000 feet above sea level, and 1 percent for each 10 degrees above 60 degrees F.