



This is a low emission engine which operates differently from previously built engines. Before starting this engine, read and understand this *Operator/Owner Manual*.



Operator/Owner Manual

Model Series 19A400, 19B400, 19C400, 19E400, 19F400, 19G400, 192400, 196400, 197400, 226400, 250400, 256400

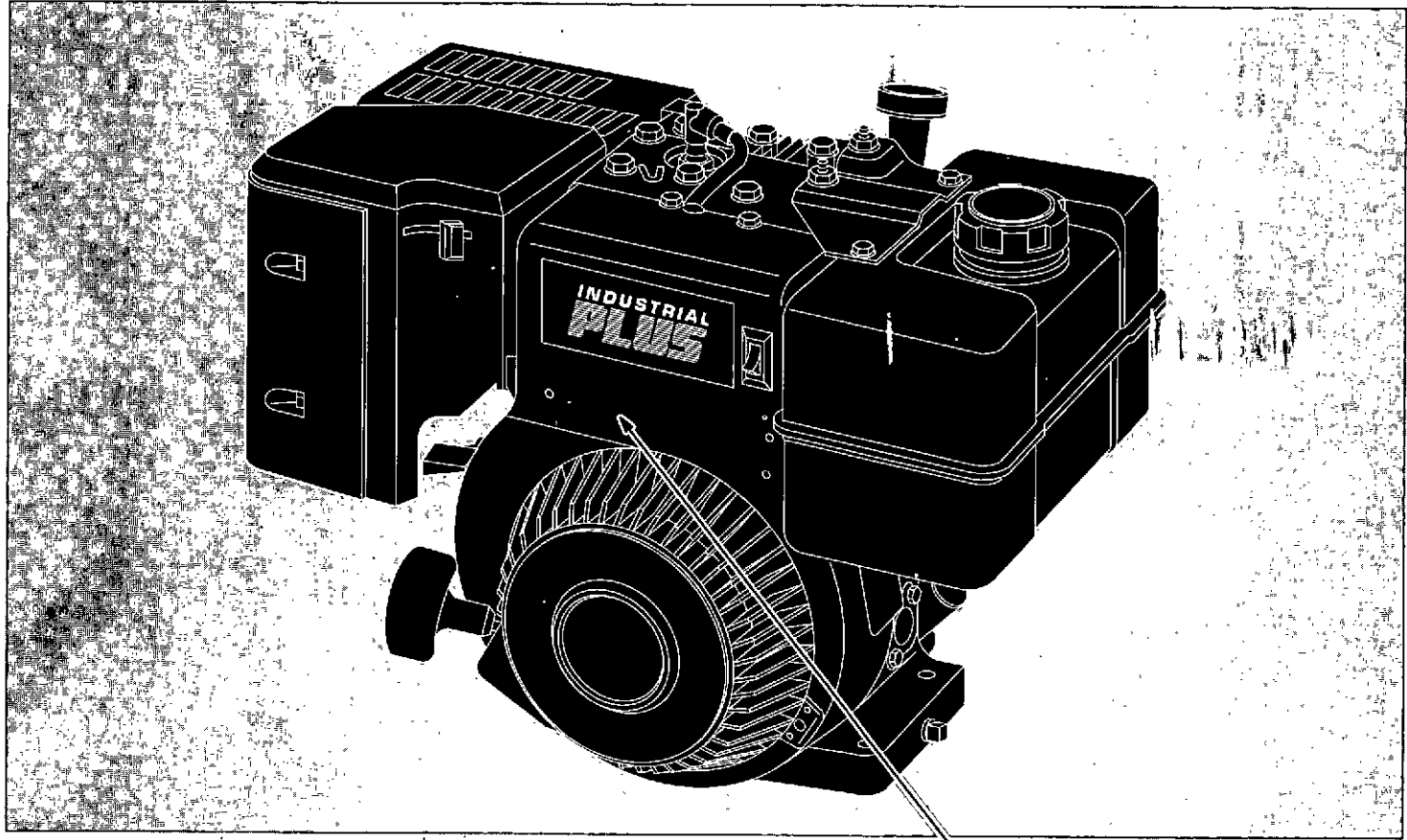

Model	Type	Code
<input type="text"/> <input type="text"/> <input type="text"/> <input type="text"/> <input type="text"/>	<input type="text"/> <input type="text"/> <input type="text"/> <input type="text"/> <input type="text"/>	<input type="text"/> <input type="text"/> <input type="text"/> <input type="text"/> <input type="text"/>

For future reference, write your *engine* Model/Type/Code here.

Table of Contents

<i>In the Interest of Safety</i>	2	<i>Maintenance Schedule</i>	8
<i>Oil & Fuel Recommendations</i>	3	<i>Service, Storage & Specifications</i>	9
<i>Starting & Stopping</i>	4	<i>Emission System Warranty</i>	10
<i>Adjustments</i>	5	<i>About Engine Warranty</i>	11
<i>Maintenance</i>	6	<i>Engine Warranty</i>	12

Briggs & Stratton Corporation
Milwaukee, Wisconsin 53201

© Copyright 1996 by Briggs & Stratton Corporation

FORM NO. 273130-4/96
PRINTED IN U.S.A.

In the Interest of Safety



This safety alert symbol indicates that this message involves personal safety. Words danger, warning and caution indicate degree of hazard. Death, personal injury and/or property damage may occur unless instructions are followed carefully.



You are not ready to operate this engine if you have not read and understood the following safety items. Read this entire owner's manual and the operating instructions of the equipment this engine powers.

The Briggs & Stratton engine you bought with your equipment is made of the finest material in a state-of-the-art manufacturing facility. Please understand that Briggs & Stratton sells engines to original equipment manufacturers. It also sells to others in the distribution chain who may sell to the ultimate consumer, an equipment manufacturer, another distributor or a dealer. As a result, Briggs & Stratton does not necessarily know the application on which the engine will be placed. For that reason, you should carefully read and understand the operating instructions of the equipment on which your engine is placed before you operate it.

You should also understand that there are equipment applications for which Briggs & Stratton does not approve the use of its engines. Briggs & Stratton engines are not to be used on vehicles with less than 4 wheels. They include motor bikes, aircraft products and All Terrain Vehicles. Moreover, Briggs & Stratton does not approve of its engines being used in competitive events. **FOR THAT REASON, BRIGGS & STRATTON ENGINES ARE NOT AUTHORIZED FOR ANY OF THESE APPLICATIONS.** Failure to follow this warning could result in death, serious injury (including paralysis) or property damage.



WARNING

DO NOT run engine in an enclosed area. (Exhaust gases contain carbon monoxide, an odorless and deadly poison.)

DO NOT place hands or feet near moving or rotating parts.

DO NOT store, spill, or use gasoline near an open flame, nor near an appliance like a stove, furnace, or water heater that uses a pilot light or can create a spark.

DO NOT refuel indoors or in an unventilated area.

DO NOT remove fuel tank cap nor fill fuel tank while engine is hot or running. (Allow engine to cool 2 minutes before refueling.)

DO NOT operate engine if gasoline is spilled or when smell of gasoline is present or other explosive conditions exist. (Move equipment away from spill and avoid any ignition until gasoline has evaporated.)

DO NOT transport engine with fuel in tank or fuel shut-off valve open.

DO NOT choke carburetor to stop engine, especially in an enclosed vehicle. (Whenever possible, gradually reduce engine speed before stopping.)

DO NOT tamper with governor springs, links or other parts to increase engine speed. (Run engine at speed set for equipment manufacturer.)

DO NOT check for spark with spark plug removed. (Use an approved tester.)

DO NOT crank engine with spark plug removed. (If engine is flooded, place throttle in FAST and crank until engine starts.)

DO NOT strike flywheel with a hammer or hard object as this may cause flywheel to shatter in operation. (To remove flywheel, use Briggs & Stratton approved tools only.)

DO NOT operate engine without a muffler. (Inspect periodically and replace if worn or leaking. If engine is equipped with muffler deflector, inspect periodically and, if necessary, replace with correct deflector.)

DO NOT operate engine with an accumulation of grass, leaves or other combustible material in muffler area.

DO NOT use this engine on any forest covered, brush covered, or grass covered unimproved land unless a spark arrester is installed on muffler. The spark arrester must be maintained in working order by the owner and/or operator. In the State of California the above is required by law (Section 4442 of the California Public Resources Code). Other states may have similar laws. Federal laws apply on federal lands.

DO NOT touch hot muffler, cylinder, or fins which can cause burns.

DO NOT start engine with air cleaner or air cleaner cover removed (or cover over carburetor air intake, if Sno/Gard engine).



WARNING

✓ PREVENT ACCIDENTAL STARTING by removing spark plug wire when servicing engine or equipment. Disconnect negative wire from battery terminal if equipped with electric starting system.

✓ KEEP cylinder fins and governor parts free of dirt, grass and other debris which can affect engine speed.

✓ PULL starter cord slowly until resistance is felt. Then pull cord rapidly to avoid kickback and prevent hand or arm injury.

✓ USE fresh gasoline. Stale fuel can gum carburetor and cause leakage.

✓ CHECK fuel lines and fittings frequently for cracks or leaks. Replace if necessary.

✓ Use only Genuine Briggs & Stratton Parts or their equivalent. The use of replacement parts which are not of equivalent quality may damage the engine.



WARNING:



The engine exhaust from this product contains chemicals known to the State of California to cause cancer, birth defects, or other reproductive harm.

International Symbols



Safety Alert



Read Owner's Manual

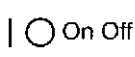

On Off



Stop



Fuel Shutoff



Fuel

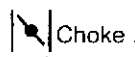

Choke

In the USA and Canada, a 24 hour hot line, 1-800-233-3723, has a menu of pre-recorded messages offering you engine maintenance information.

Oil & Fuel Recommendations



This engine is shipped from Briggs & Stratton without oil. Before starting engine, check oil level as shown below.

Change and add oil according to chart below. Do not over-fill. Use a high quality detergent oil classified "For Service SE, SF, SG," such as Briggs & Stratton "warranty certified" SAE 30 oil, Part No. 100005. Use no special additives with recommended oils. Do not mix oil with gasoline.

SAE Viscosity Grades

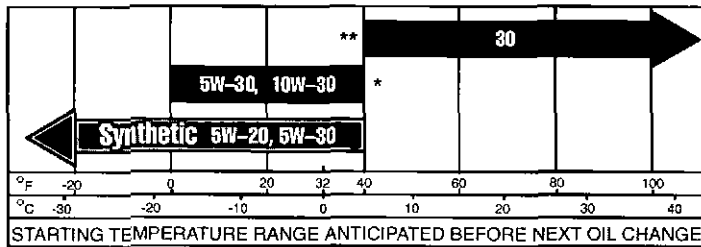

- * Air cooled engines run hotter than automotive engines. Use of multi-viscosity oils (10W-30, etc.) above 40° F (4° C) will result in high oil consumption and possible engine damage. Check oil level more frequently if using these types of oils.
- ** SAE 30 oil, if used below 40° F (4° C), will result in hard starting and possible engine bore damage due to inadequate lubrication.

Check oil level before starting engine.

Add oil as shown below.

Note: Gear reduction, if this engine is equipped, must also be filled with oil. See oil filling instructions on page 6.

Oil capacity of Model Series 190000 and 220000 is about 1-3/8 quarts (44 ounces or 1.3 liters).

Oil capacity of Model Series 250000 is about 1-1/2 quarts (48 ounces or 1.4 liters).

After filling with or changing oil, start and run engine at idle for 30 seconds. Shut engine off. Wait 30 seconds and check oil level. Add oil, if required, to bring level to **Full** mark on dipstick.

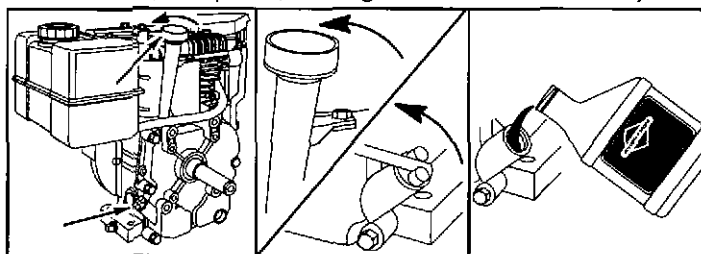

Place engine level. Clean around oil fill. Remove oil filler plug or dipstick. Fill to overflowing for oil filler plug.

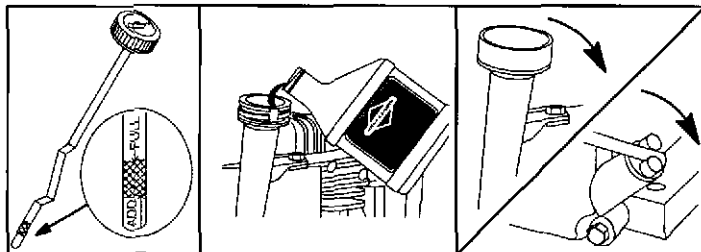

Fill to FULL mark on dipstick. If oil is required, add slowly. Recheck. Tighten plug/dipstick before starting.



Fuel

Use clean, fresh, unleaded gasoline with a minimum of 87 octane. Do not mix oil with gasoline. Purchase fuel in quantity that can be used within 30 days to assure fuel freshness. We recommend the use of Briggs & Stratton Gasoline Additive. (See your Authorized Briggs & Stratton Service Dealer for Part No. 5041 or the single-use pouch.) In countries other than U.S.A., leaded gasoline may be used if it is commercially available and unleaded is unavailable.

Note: Some fuels, called oxygenated or reformulated gasolines, are gasolines blended with alcohols or ethers. Excessive amounts of these blends can damage the fuel system or cause performance problems. Do not use gasoline which contains Methanol. If any undesirable operating symptoms occur, use gasoline with a lower percentage of alcohol or ether.

See storage instructions, on page 9. We recommend the use of Briggs & Stratton Gasoline Additive, Part No. 5041 or the single-use storage pouch.

Do not over-fill fuel tank.

Allow space for fuel expansion.

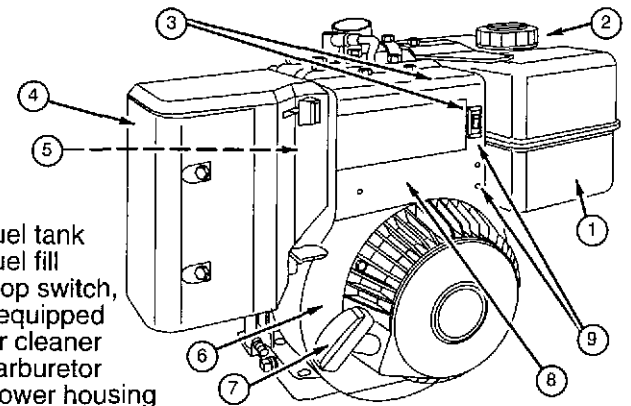
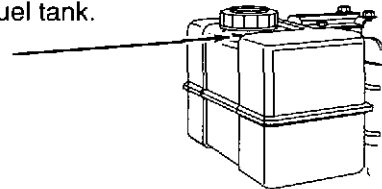

1. Fuel tank
2. Fuel fill
3. Stop switch, if equipped
4. Air cleaner
5. Carburetor
6. Blower housing
7. Rope handle
8. Engine Model Type Code
xxxxxx xxxx xx xxxxxxxx
9. OIL GARD®, if equipped, and stop switch

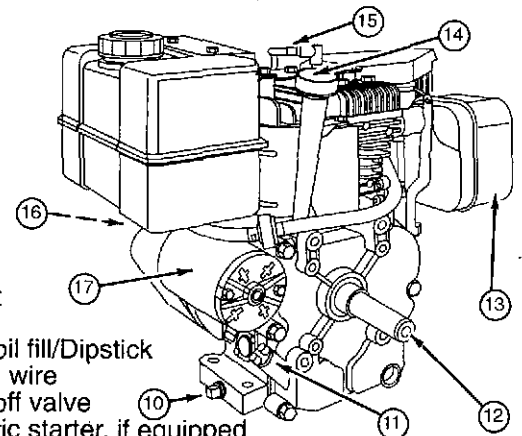

10. Oil drain
11. Oil fill plug
12. Crankshaft
13. Muffler
14. Extended oil fill/Dipstick
15. Spark plug wire
16. Fuel shut-off valve
17. 12 V electric starter, if equipped

In the USA and Canada, a 24 hour hot line, 1-800-233-3723, has a menu of pre-recorded messages offering you engine maintenance information.

Starting & Stopping

Choke operation/engine warm-up

This engine is designed for maximum performance and life if operated with the choke fully open (in RUN) and throttle fully open (in FAST). To open the choke fully requires an engine warm-up period of several seconds to several minutes, depending on the temperature.

After starting engine, first open the choke (toward RUN) until the engine just begins to run smoothly. Then open the choke in small steps, allowing the engine to accept small changes in speed and load, until the choke is fully open (in RUN).

During engine warm-up, the equipment can be operated.

Tips to obtain best starting results

Start, store and fuel equipment in level position.

! Do not use a pressurized starting fluid. Starting fluid is flammable. Severe engine damage or fire may occur.

A warm engine requires less choking than a cold engine.

Starting in cold weather:

Use the correct oil for the starting temperature expected.

De-clutch all possible external loads.

A warm battery has more starting capacity than a cold battery.

Do not use gasoline left over from summer. Use fresh winter grade gasoline which has higher volatility to improve starting.

Before starting engine

Move choke control to CHOKE position and throttle control to FAST position.

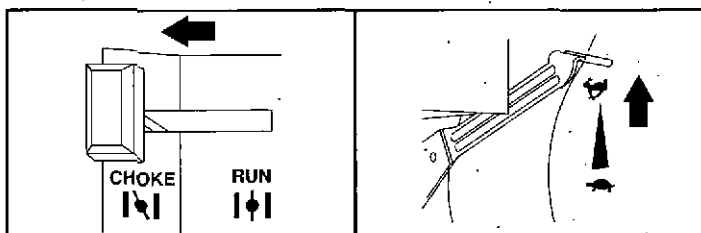

Choke control

Throttle control

Turn fuel shut-off valve on, if equipped.

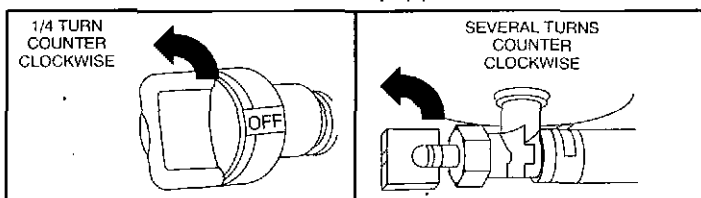

Fuel shut-off valves

Move stop control to ON position, if equipped.

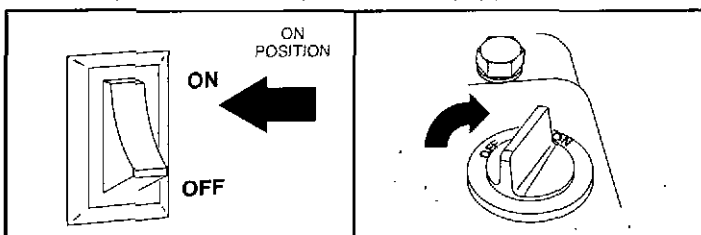

Stop switches

Start engine

! Always keep hands and feet clear of mower blade or other rotating machinery.

Rewind starter

! Grasp rope handle as illustrated and pull slowly until resistance is felt. Then pull cord rapidly to overcome compression, prevent kickback and start engine. Repeat if necessary with choke off and throttle control in FAST position. Operate engine in FAST position.

Note: OIL GARD® light warns of low oil level, if equipped. If light flickers when trying to start or restart engine, add oil. Fill to FULL mark on dipstick or to overflowing at oil fill plug.

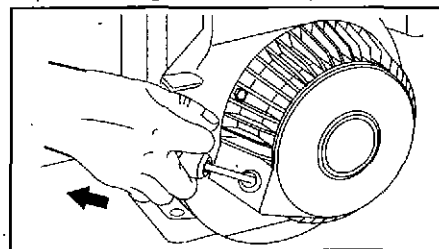

Rewind starter

Electric starter, if equipped

On engines equipped with 12 volt starting system, turn key to START or press starter button. Repeat if necessary with throttle control in FAST position. Operate engine in FAST position.

Note: If equipment manufacturer has supplied battery, charge it before trying to start engine, as equipment manufacturer recommends. Use short starting cycles (15 secs. per min.) to prolong starter life. Extended cranking can damage starter motor.

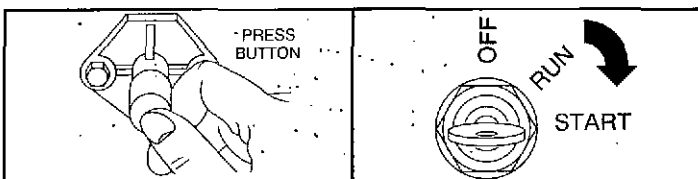

Typical starter switches

Stop engine

Do not move choke control to CHOKE position to stop engine. Backfire or engine damage may occur. Move throttle control to SLOW position, then move stop switch or turn key to OFF, if equipped. Always remove key from switch when equipment is not in use or left unattended.

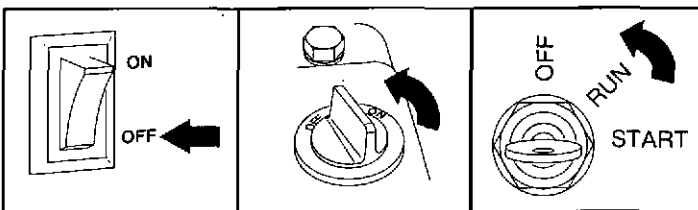

Typical stop switches

When engine is transported, close fuel shut-off valve to prevent leakage.

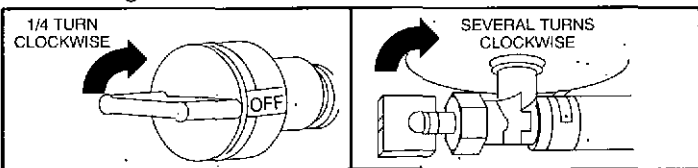

Fuel shut-off valves

In the USA and Canada, a 24 hour hot line, 1-800-233-3723, has a menu of pre-recorded messages offering you engine maintenance information.

Adjustments

Control adjustments

 To prevent accidental starting, remove spark plug wire and disconnect battery at negative terminal, when adjusting controls.

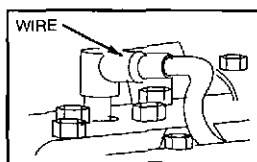

To adjust manual friction throttle control:

Loosen or tighten wing nut on control plate until throttle control moves with some resistance and still remains in desired position when engine is running.

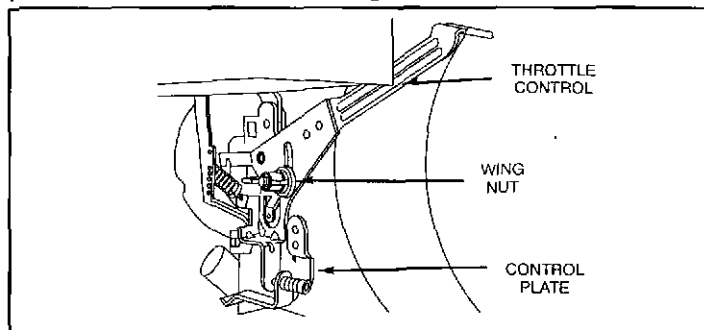

Manual friction throttle control

To adjust remote throttle control:

Loosen casing clamp screw on control plate. Move casing and wire in direction of arrow to end of travel. Move throttle control to FAST position. Tighten casing clamp screw.

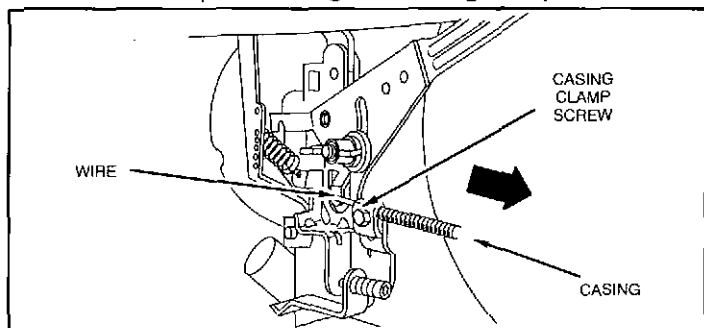

Remote throttle control

Adjustable governor control

Top No-Load speed adjusting screw has been pre-set at the factory as specified by equipment manufacturer. **DO NOT ADJUST.** If adjustment is required, consult any Briggs & Stratton Authorized Service Dealer.

Note: If engine is equipped with adjustable governor, it may also be equipped with electromagnetic "idle down." See equipment manufacturer's instructions for operation of "idle down."

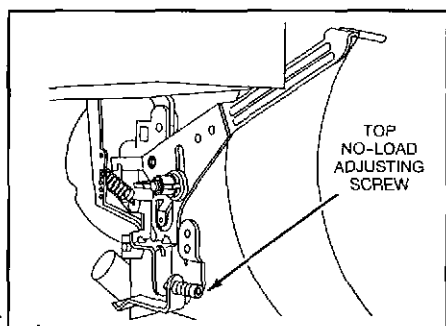

Adjustable governor

Carburetor adjustments



The manufacturer of equipment on which this engine is installed specifies top speed at which engine will be operated. **DO NOT EXCEED** this speed.

Differences in fuel, temperature, altitude or load may require minor carburetor adjustment. Air cleaner and air cleaner cover must be assembled to carburetor before starting engine.

The carburetor on this engine is low emission. It is equipped with an idle mixture valve with a limiter (see inset), which allows some adjustment, and an idle speed adjustment screw.

Adjustments

Start engine and warm up approximately 5 minutes before adjusting. With engine running, place throttle control in SLOW position. Rotate carburetor throttle lever against the idle speed screw and hold it. Turn idle speed screw to obtain 1750 rpm.

Rotate idle mixture valve full travel clockwise and then counterclockwise. Finally, position idle mixture valve in middle of travel. Check idle speed and re-adjust to 1750 rpm, if necessary.

Move throttle control to FAST position. Engine should accelerate smoothly. If it does not, adjust idle mixture valve counterclockwise 1/8 turn.

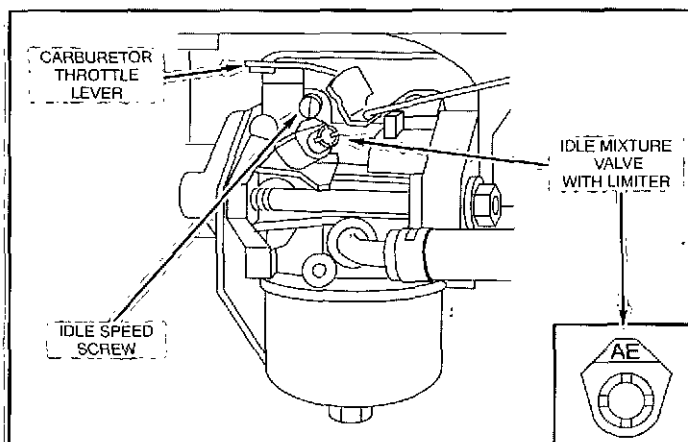

Carburetor adjustments

Maintenance

See Maintenance Schedule, page 8. Follow the hourly or calendar intervals, whichever occur first. Note that more frequent service is required when operating in adverse conditions.

⚠ To prevent accidental starting, remove spark plug wire and disconnect battery at negative terminal, when servicing engine or equipment.

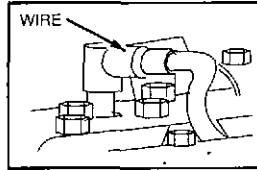

Oil

Check oil level regularly.

Be sure correct oil level is maintained. Check every 5 hours or daily, before starting engine. See **Check oil level** page 3.

Change oil (Follow *Maintenance Schedule*.)

Change oil after first 5 hours of operation. Remove drain plug and drain oil while engine is warm. Replace drain plug. Remove dipstick and refill with new oil of recommended grade (see chart, page 3). Start and run engine at idle for 30 seconds. Stop engine. Wait 30 seconds and re-check oil level. If required, add oil to bring level to **FULL** mark on dipstick.

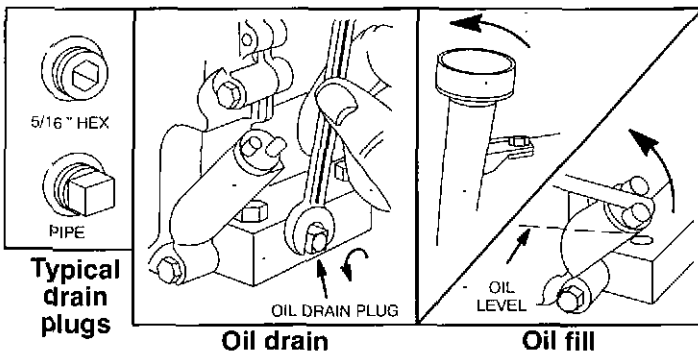

Gear reduction, if equipped

Remove oil level plug and oil fill plug. Drain oil every 100 hours of operation or every season. To refill, pour SAE 30 oil into oil fill hole until it runs out level check hole. Replace both plugs. Oil fill plug has a vent hole and must be installed on top of gear case cover.

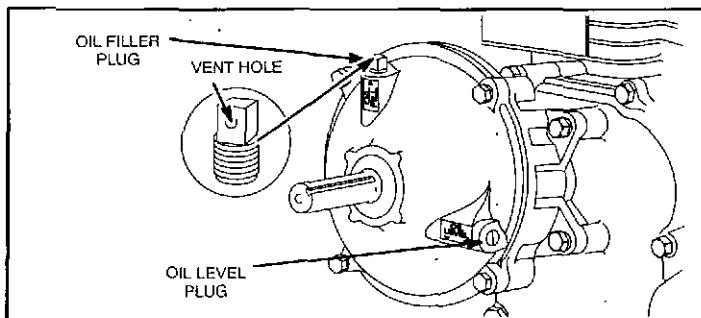

Oil drain/oil fill

⚠ Air cleaner

Note: Service according to Maintenance Schedule.

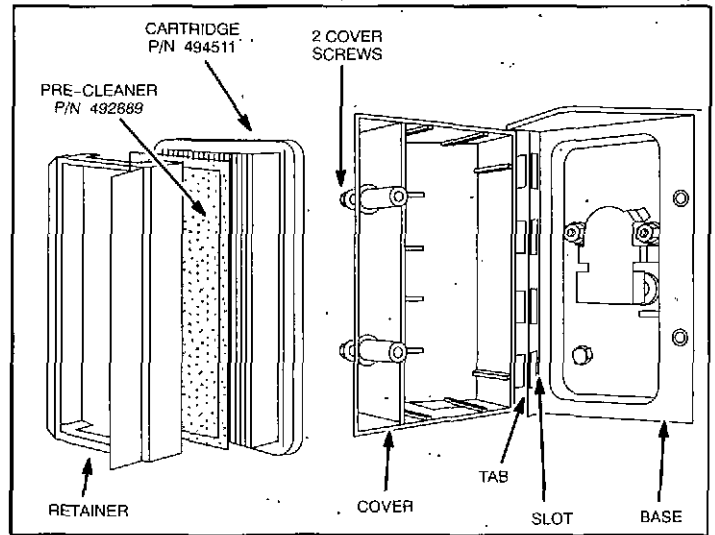

Dual element air cleaner

1. Loosen cover screws. Remove cover and air cleaner assembly from base.
2. Remove air cleaner assembly from inside of cover and disassemble.

To service pre-cleaner, wash in liquid detergent and water. Squeeze dry in a clean cloth. Saturate in engine oil. Squeeze in clean, absorbent cloth to remove ALL EXCESS oil. If very dirty or damaged, replace it:

Note: Depending on engine Type Number, this engine may not be equipped with a pre-cleaner.

To service cartridge, clean by tapping gently on a flat surface. If very dirty or damaged, replace it. Do not oil cartridge.

Note: Do not use petroleum solvents, e.g., kerosene, nor pressurized air to clean cartridge. Solvents will cause cartridge to deteriorate. Pressurized air can damage cartridge.

3. Reassemble retainer on pre-cleaner and cartridge (screen side of pre-cleaner toward cartridge pleats). Install this assembly in cover.
4. Insert tabs on cover into slots in base. Tighten cover screws securely.

Keep muffler area clean and muffler in working order.

⚠ Daily or more often, before running engine, clean muffler area to remove all combustible debris.

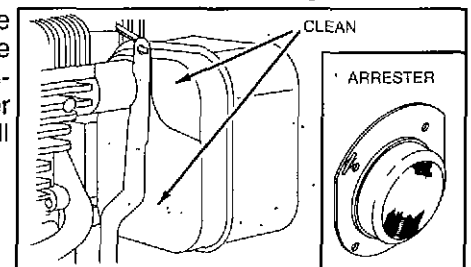

Muffler area

If engine muffler is equipped with spark arrester screen, remove for cleaning and inspection. Replace if damaged or plugged.

In the USA and Canada, a 24-hour hot line, 1-800-233-3723, has a menu of pre-recorded messages offering you engine maintenance information.

Maintenance

See Maintenance Schedule, page 8. Follow the hourly or calendar intervals, whichever occur first. Note that more frequent service is required when operating in adverse conditions.

Keep engine and parts clean.

With a brush or cloth, remove debris from debris guard or rotating screen daily or more often if needed to prevent engine damage caused by overheating. Do not clean with a forceful spray of water because water could contaminate fuel system.

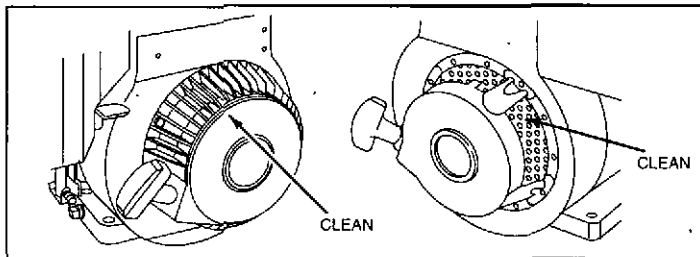

Finger guard/Rotating screen

Debris or chaff may clog the air cooling system, especially after prolonged operation. Remove blower housing and clean area shown to prevent overheating and engine damage.

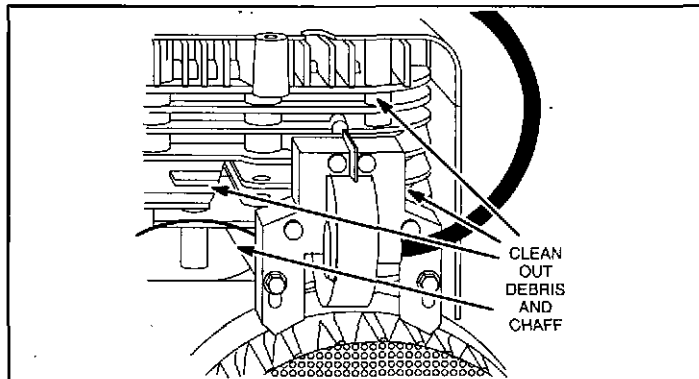

Air cooling system

To assure smooth operation, keep governor linkage, springs and controls free of debris.

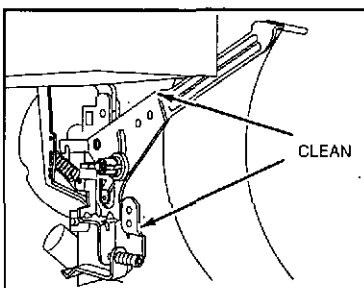

Linkage, springs & controls

Replace or clean spark plug. Do not blast clean. Clean by scraping or wire brushing and washing with a commercial solvent.

Use only Briggs & Stratton Spark Tester, Part No. 19368, to check for spark.

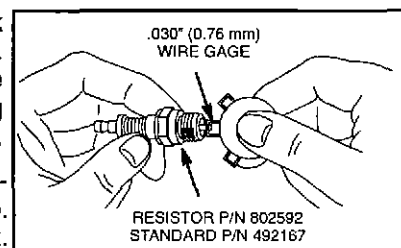

Spark plug

Note: In some areas, local law requires using resistor spark plugs to suppress ignition signals. If this engine was originally equipped with a resistor spark plug, use same type for replacement.

Replace In-Line fuel filter, if engine is equipped.



Drain fuel tank or close fuel shut-off valve before replacing fuel filter.

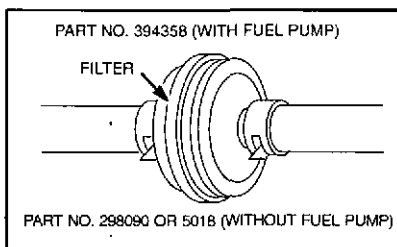

Fuel filter

Remove combustion deposits.

Remove cylinder head every 100-300 hours of operation. Scrape and wire brush combustion deposits from cylinder, cylinder head, top of piston and around valves. Use a soft brush to remove deposits. Reassemble gasket and cylinder head. Turn screws down finger tight. Torque cylinder head screws in a staggered sequence to 165 in.-lbs. (19 Nm).

See any Authorized Briggs & Stratton Service Dealer. Insist on Genuine Briggs & Stratton parts! Non-original parts may not perform as well and may void your warranty.

273130

To obtain a complete Parts List of Genuine Briggs & Stratton Parts for your engine, fill in your engine Model/Type/Code below and print your name and address on the other side. We cannot fill your order without the correct Model/Type/Code. (Please allow 3 to 4 weeks for delivery.)

Your Engine	Model	Type	Code
<input type="text"/>	<input type="text"/>	<input type="text"/>	<input type="text"/>

Cut out and send (with \$2) to: Briggs & Stratton Corporation
Attn: Service Division
P.O. Box 1144
Milwaukee, WI 53201-1144

Maintenance Schedule

273130

Follow the hourly or calendar intervals, whichever occur first.

More frequent service is required when operating in adverse conditions noted below.

Maintenance Operation	Every 5 Hours or Daily	25 Hours or Every Season	50 Hours or Every Season	100 Hours or Every Season	100-300 Hours
Check oil level	•				
Change oil ♦			• Note 1		
Change oil in gear reduction, if equipped				•	
Service air cleaner pre-cleaner, if equipped		• Note 2			
Service air cleaner cartridge, if not equipped with pre-cleaner		• Note 2			
Service air cleaner cartridge, if equipped with pre-cleaner				• Note 2	
Clean cooling system				• Note 2	
Inspect spark arrester, if equipped			•		
Replace or clean spark plug				•	
Replace in-line fuel filter, if equipped				•	
Clean combustion chamber deposits					•
♦	Change oil after first 5 hours, then after every 50 hours or every season.				
Note 1:	Change oil every 25 hours when operating under heavy load or in high temperatures.				
Note 2:	Clean more often under dusty conditions or when airborne debris is present. Replace air cleaner parts, if very dirty.				

Briggs & Stratton Part Numbers of some Genuine Briggs & Stratton Parts:

Part	Briggs & Stratton Part No.
Air cleaner cartridge	494511
Air cleaner pre-cleaner	492889
Pre-cleaner and cartridge	5050
Standard spark plug	492167
Resistor spark plug	802592
Spark plug elbow	66538
Spark plug wrench	89838 or 5023
Spark tester	19368

Briggs & Stratton Part Numbers of some Genuine Briggs & Stratton Parts:

Part	Briggs & Stratton Part No.
Fuel filter (w/o fuel pump)	298090 or 5018
Fuel filter (with fuel pump)	394358
Oil	100005 or 100028
Gas additive	5041

From: **Briggs & Stratton Corporation**
 Literature Department
 P.O. Box 702
 Milwaukee, WI 53201-0702 U.S.A.

To:

Name _____

Address _____

City, State, Zip _____

Only Genuine Briggs & Stratton Parts have the Briggs & Stratton logo!



Look for Briggs & Stratton logo stamped on part and/or package!

In the USA and Canada, a 24 hour hot line, 1-800-233-3723, has a menu of pre-recorded messages offering you engine maintenance information.

Service, Storage & Specifications

For service

See an Authorized Briggs & Stratton Service Dealer. Each one carries a stock of Genuine Briggs & Stratton Parts and is equipped with special service tools. Trained mechanics assure expert repair service on all Briggs & Stratton engines. Only dealers advertising as "Authorized Briggs & Stratton" are required to meet Briggs & Stratton standards.



You may locate your nearest Authorized Briggs & Stratton Service Dealer in the "Yellow Pages"™ directory under "Engines, Gasoline" or "Gasoline Engines," or "Lawn Mowers" or similar category. There are over 30,000 Authorized Service Dealers worldwide available to serve you.

Note: Walking fingers logo and "Yellow Pages" are registered trademarks in various jurisdictions.

The illustrated shop manual shown here includes "Theories of Operation," common specifications and detailed information covering adjustment, tune-up and repair of Briggs & Stratton L-head, single cylinder, 4 cycle engines. It is available from an Authorized Briggs & Stratton Service Dealer or you can order it from the factory. Write:

Briggs & Stratton Corporation
Attn: Service Division
P. O. Box 1144
Milwaukee, WI 53201



Part No. 270962

Storage instructions

Engines stored over 30 days need to be protected or drained of fuel to prevent gum from forming in fuel system or on essential carburetor parts.

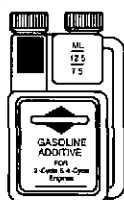

P/N 5041

1. For engine protection, we recommend use of Briggs & Stratton Gasoline Additive, Part No. 5041, available from an Authorized Briggs & Stratton Service Dealer. Mix Additive with fuel in fuel tank or storage container. Run engine for a short time to circulate Additive through carburetor. Engine and fuel can be stored up to 24 months.

Your Service Dealer has single-use pouches of Gasoline Additive available.



Note: If engine is operating on oxygenated or reformulated gasoline (gasoline blended with an alcohol or an ether), remove all fuel from tank and run engine until it stops from lack of fuel. If engine is stored with gasoline in fuel tank, we recommend the use of Gasoline Additive, Part No. 5041.

2. While engine is still warm, drain oil from crankcase (see page 6). Refill with fresh oil of recommended grade (see chart page 3).
3. Remove spark plug and pour about 1 oz (30 ml) of engine oil into cylinders. Replace spark plug and crank slowly to distribute oil.
4. Clean dirt and chaff from cylinder, cylinder head fins, blower housing, rotating screen and muffler area (see page 7).
5. Store in a clean and dry area, but NOT near a stove, furnace or water heater which uses a pilot light or any device that can create a spark.

General information

This is a single cylinder, L-head, air cooled engine.

On mobile equipment, this engine will operate satisfactorily at any angle at which operator and equipment can function safely.

Model Series 19A400, 19B400, 19C400, 19E400, 19F400, 19G400, 192400, 196400, 197400

Bore 3 in. (76.20 mm)
Stroke 2-3/4 in. (69.85 mm)
Displacement 19.44 cu. in. (318.5 cc)
Torque (Max.) 12.7 ft. lbs. @ 2500 rpm

Model Series 226400

Bore 3-7/16 in. (87.31 mm)
Stroke 2-3/8 in. (60.33 mm)
Displacement 22.04 cu. in. (361.2 cc)
Torque (Max.) 14.8 ft. lbs. @ 3000 rpm

In the USA and Canada, a 24 hour hot line, 1-800-233-3723, has a menu of pre-recorded messages offering you engine maintenance information.

Model Series 250400, 256400

Bore 3-7/16 in. (87.31 mm)
Stroke 2-5/8 in. (66.68 mm)
Displacement 24.36 cu. in. (399.3 cc)
Torque (Max.) 16.8 ft. lbs. @ 2800 rpm

Note: For practical operation, the horsepower loading should not exceed 85% of rated horsepower. Engine power will decrease 3-1/2% for each 1,000 feet (300 meters) above sea level and 1% for each 10° F (5.6° C) above 60° F (16° C).

Tune up specifications

Valve clearance is:

Intake*005-.007 in. (.13-.18 mm)
Exhaust*009-.011 in. (.23-.28 mm)

* with valve springs installed and piston 1/4 in. (6mm) past top dead center.

**Briggs & Stratton Corporation and the California Air Resources Board
Emission Control System Warranty Statement
(Owner's Defect Warranty Rights and Obligations)**

FORM #273130

In the interest of the environment, Briggs & Stratton engines that meet strict emission requirements are labeled, "This ULGE engine conforms to 1995-1998 California Emission Control Regulations."

California Emission Control Defects Warranty Statement

The California Air Resources Board and Briggs & Stratton Corporation are pleased to explain the emission control system warranty on your 1995 utility or lawn and garden equipment engine (ULGE). In California, new utility or lawn and garden equipment engines must be designed, built and equipped to meet the state's stringent anti-smog standards. Briggs & Stratton must warrant the emission control system on your engine for the periods of time listed below, provided there has been no abuse, neglect or improper maintenance of

Briggs & Stratton Emission Control Defects Warranty Coverage

The utility or lawn and garden equipment engines are warranted relative to emission control parts defects for a period of two years, sub-

Owner's Warranty Responsibilities

As the utility or lawn and garden equipment owner, you are responsible for the performance of the required maintenance listed in your Owner's Manual. Briggs & Stratton recommends that you retain all your receipts covering maintenance on your utility or lawn and garden equipment engine, but Briggs & Stratton cannot deny warranty solely for the lack of receipts or for your failure to ensure the performance of all scheduled maintenance.

As the utility or lawn and garden equipment engine owner, you should however be aware that Briggs & Stratton may deny you warranty coverage if your utility or lawn and garden equipment engine or a part has failed due to abuse, neglect, improper maintenance or

Briggs & Stratton Emission Control Defects Warranty Provisions

The following are specific provisions relative to your Emission Control Defects Warranty Coverage. It is in addition to the Briggs & Stratton engine warranty for non-regulated engines found in the Owner's Manual.

1. Warranted Parts

Coverage under this warranty extends only to the parts listed below (the emission control systems parts) to the extent these parts were present on the engine purchased.

a. Fuel Metering System

- Cold start enrichment system (soft choke)
- Fuel Pump

b. Air Induction System

- Air cleaner
- Carburetor and internal parts
- Intake manifold

c. Ignition System

- Spark plug(s)
- Magneto ignition system

d. Catalyst System

- Catalytic converter
- Exhaust manifold
- Air injection system or pulse valve

e. Miscellaneous Items Used in Above Systems

- Vacuum, temperature, position, time sensitive valves and switches
- Connectors and assemblies

2. Length of Coverage

Briggs & Stratton warrants to the initial owner and each subsequent purchaser that the Warranted Parts shall be free from defects in materials and workmanship which caused the failure of the Warranted Parts for a period of two years from the date the engine is delivered to a retail purchaser.

EMISSION CONTROL WARRANTY COVERAGE IS APPLICABLE ONLY TO ENGINES PURCHASED IN CALIFORNIA IN 1995 AND THEREAFTER WHICH ARE USED IN CALIFORNIA.

your utility or lawn and garden equipment engine.

Your emission control system includes parts such as the carburetor, air cleaner, ignition system, muffler and catalytic converter. Also included may be connectors and other emission related assemblies.

Where a warrantable condition exists, Briggs & Stratton will repair your utility or lawn and garden equipment engine at no cost to you including diagnosis, parts and labor.

ject to provisions set forth below. If any covered part on your engine is defective, the part will be repaired or replaced by Briggs & Stratton.

unapproved modifications.

You are responsible for presenting your utility or lawn and garden equipment engine to an Authorized Briggs & Stratton Service Dealer as soon as a problem exists. The undisputed warranty repairs should be completed in a reasonable amount of time, not to exceed 30 days. If you have any questions regarding your warranty rights and responsibilities, you should contact a Briggs & Stratton Service Representative at 1-414-259-5262.

The emission warranty is a defects warranty. Defects are judged on normal engine performance. The warranty is not related to an in-use emission test.

3. No Charge

Repair or replacement of any Warranted Part will be performed at no charge to the owner, including diagnostic labor which leads to the determination that a Warranted Part is defective, if the diagnostic work is performed at an Authorized Briggs & Stratton Service Dealer. For emissions warranty service contact your nearest Authorized Briggs & Stratton Service Dealer as listed in the "Yellow Pages" under "Engines, Gasoline," "Gasoline Engines," "Lawn Mowers," or similar category.

4. Claims and Coverage Exclusions

Warranty claims shall be filed in accordance with the provisions of the Briggs & Stratton Engine Warranty Policy. Warranty coverage shall be excluded for failures of Warranted Parts which are not original Briggs & Stratton parts or because of abuse, neglect or improper maintenance as set forth in the Briggs & Stratton Engine Warranty Policy. Briggs & Stratton is not liable to cover failures of Warranted Parts caused by the use of add-on, non-original, or modified parts.

5. Maintenance

Any Warranted Part which is not scheduled for replacement as required maintenance or which is scheduled only for regular inspection to the effect of "repair or replace as necessary" shall be warranted as to defects for the warranty period. Any Warranted Part which is scheduled for replacement as required maintenance shall be warranted as to defects only for the period of time up to the first scheduled replacement for that part. Any replacement part that is equivalent in performance and durability may be used in the performance of any maintenance or repairs. The owner is responsible for the performance of all required maintenance, as defined in the Briggs & Stratton Owner's Manual.

6. Consequential Coverage

Coverage hereunder shall extend to the failure of any engine components caused by the failure of any Warranted Part still under warranty.

In the USA and Canada, a 24 hour hot line, **1-800-233-3723**, has a menu of pre-recorded messages offering you engine maintenance information.

About your engine warranty: (see back cover for statement of LIMITED WARRANTY.)

Briggs & Stratton welcomes warranty repair and apologizes to you for being inconvenienced. Any Authorized Service Dealer may perform warranty repairs. Most warranty repairs are handled routinely, but sometimes requests for warranty service may not be appropriate. For example, warranty would not apply if engine damage occurred because of misuse, lack of routine maintenance, shipping, handling, warehousing or improper installation. Similarly, warranty is void if the serial number of the engine has been removed or the engine has been altered or modified.

If a customer differs with the decision of the Service Dealer, an investigation will be made to determine whether the warranty applies. Ask the Service Dealer to submit all supporting facts to his Distributor or the Factory for review. If the Distributor or the Factory decides that the claim is justified, the customer will be fully reimbursed for those items that are defective. To avoid misunderstanding which might occur between the customer and the Dealer, listed below are some of the causes of engine failure that the warranty does not cover.

Improper maintenance:

The life of an engine depends upon the conditions under which it operates, and the care it receives. Some applications, such as tillers, pumps and rotary mowers, are very often used in dusty or dirty conditions, which can cause what appears to be premature wear. Such wear, when caused by dirt, dust, spark plug cleaning grit, or other abrasive material that has entered the engine because of improper maintenance, is not covered by warranty.

This warranty covers engine related defective material and/or workmanship only, and not replacement or refund of the equipment to which the engine may be mounted. Nor does the warranty extend to repairs required because of:

1. PROBLEMS CAUSED BY PARTS THAT ARE NOT ORIGINAL BRIGGS & STRATTON PARTS.
2. Equipment controls or installations that prevent starting, cause unsatisfactory engine performance, or shorten engine life. (Contact equipment manufacturer.)
3. Leaking carburetors, clogged fuel pipes, sticking valves, or other damage, caused by using contaminated or stale

- fuel. (Use clean, fresh, lead-free gasoline and Briggs & Stratton gasoline stabilizer, Part No. 5041.)
4. Parts which are scored or broken because an engine was operated with insufficient or contaminated lubricating oil, or an incorrect grade of lubricating oil (check oil level daily or after every 8 hours of operation. Refill when necessary and change at recommended intervals.) Read "Owner's Manual."
5. Repair or adjustment of associated parts or assemblies such as clutches, transmissions, remote controls, etc., which are not manufactured by Briggs & Stratton.
6. Damage or wear to parts caused by dirt, which entered the engine because of improper air cleaner maintenance, re-assembly, or use of a non-original air cleaner element or cartridge. (At recommended intervals, clean and re-oil the Oil-Foam® element or the foam pre-cleaner, and replace the cartridge.) Read "Owner's Manual."
7. Parts damaged by overspeeding, or overheating caused by grass, debris, or dirt, which plugs or clogs the cooling fins, or flywheel area, or damage caused by operating the engine in a confined area without sufficient ventilation. (Clean fins on the cylinder, cylinder head and flywheel at recommended intervals.) Read "Owner's Manual."
8. Engine or equipment parts broken by excessive vibration caused by a loose engine mounting, loose cutter blades, unbalanced blades or loose or unbalanced impellers, improper attachment of equipment to engine crankshaft, overspeeding or other abuse in operation.
9. A bent or broken crankshaft, caused by striking a solid object with the cutter blade of a rotary lawn mower, or excessive v-belt tightness.
10. Routine tune-up or adjustment of the engine.
11. Engine or engine component failure, i.e., combustion chamber, valves, valve seats, valve guides, or burned starter motor windings, caused by the use of alternate fuels such as, liquified petroleum, natural gas, altered gasolines, etc.

Warranty is available only through service dealers which have been authorized by Briggs & Stratton Corporation. your nearest Authorized Service Dealer is listed in the "Yellow Pages™" of your telephone directory under "Engines, Gasoline" or "Gasoline Engines," "Lawn Mowers," or similar category.

Briggs & Stratton Engines Are Made Under One Or More Of The Following Patents: Design D-247,177 (Other Patents Pending)

5,271,363	5,197,425	5,105,331	5,016,588	4,971,219	4,520,288	4,270,509	DES. 309,458
5,269,713	5,197,422	5,086,890	4,996,956	4,895,119	4,453,507	4,233,534	DES. 309,457
5,265,700	5,191,864	5,040,644	4,995,357	4,819,593	4,430,984	4,168,288	DES. 308,872
5,243,878	5,150,674	5,040,503	4,977,879	4,694,792	4,355,253	4,068,636	DES. 308,871

In the USA and Canada, a 24 hour hot line, **1-800-233-3723**, has a menu of pre-recorded messages offering you engine maintenance information.

BRIGGS & STRATTON ENGINE OWNER WARRANTY POLICY
effective February 1, 1994

Replaces all undated Warranties and all Warranties
dated before February 1, 1994

LIMITED WARRANTY

"Briggs & Stratton Corporation will repair or replace, free of charge, any part, or parts of the engine that are defective in material or workmanship or both. Transportation charges on parts submitted for repair or replacement under this Warranty must be borne by purchaser. This warranty is effective for the time periods and subject to the conditions provided for in this policy. For warranty service contact your nearest Authorized Service Dealer as listed in the 'Yellow Pages™' under 'Engines, Gasoline,' 'Gasoline Engines,' 'Lawn Mowers' or similar category. THERE IS NO OTHER EXPRESS WARRANTY. IMPLIED WARRANTIES, INCLUDING THOSE OF MERCHANTABILITY AND FITNESS FOR A PARTICULAR PURPOSE ARE LIMITED TO ONE YEAR FROM PURCHASE, OR TO THE EXTENT PERMITTED BY LAW ANY AND ALL IMPLIED WARRANTIES ARE EXCLUDED. LIABILITY FOR CONSEQUENTIAL DAMAGES UNDER ANY AND ALL WARRANTIES ARE EXCLUDED TO THE EXTENT EXCLUSION IS PERMITTED BY LAW. Some states do not allow limitations on how long an implied warranty lasts, and some states do not allow the exclusion or limitation of incidental or consequential damages, so the above limitation and exclusion may not apply to you. This warranty gives you specific legal rights and you may also have other rights which vary from state to state."

Briggs & Stratton Corporation

F. P. Stratton, Jr.

F. P. Stratton, Jr.
Chairman and Chief Executive Officer

WARRANTY PERIOD

ENGINES	WITHIN U.S.A. AND CANADA		OUTSIDE U.S.A. AND CANADA	
	CONSUMER USE*	COMMERCIAL USE*	CONSUMER USE*	COMMERCIAL USE*
All Vanguard™ engines.	2 year - engine / Lifetime** - Magnetron® ignition			
All Diamond Plus®, Europa™, Industrial Plus™ and all I/C®.	2 year	1 year	2 year	1 year
Quantum® and Diamond Power®.	2 year	90 days	2 year †	90 days
All standard 2 through 18 HP engines installed on lawn mowers, riders, edgers, tillers, and all Sno/Gard engines.	2 year	90 days	1 year	90 days
All other standard 2 through 18 HP engines.	1 year	90 days	1 year	90 days

* For purposes of this warranty policy, "consumer use" means personal residential household use by the original retail consumer. "Commercial use" means all other uses, including use for commercial, income producing or rental purposes. Once an engine has experienced commercial use, it shall thereafter be considered as a commercial use engine for purposes of this warranty. **Engines used in competitive racing or on commercial or rental tracks are not warrantied.**

** Lifetime limited warranty of the Magnetron® ignition covers parts and labor for the first five (5) years from the date of purchase; thereafter only parts. "Lifetime" means lifetime of the engine in the hands of the original purchaser.

† One (1) year in Australia, New Zealand, Middle East and Africa.

NO WARRANTY REGISTRATION CARD IS NECESSARY TO OBTAIN WARRANTY ON BRIGGS & STRATTON ENGINES. YOU MUST SAVE THE PURCHASE RECEIPT. A PROOF OF PURCHASE DATE WILL BE REQUIRED TO OBTAIN WARRANTY.

In the USA and Canada, a 24 hour hot line, 1-800-233-3723, has a menu of pre-recorded messages offering you engine maintenance information.