

FOREWORD

Before attempting a twin cylinder engine overhaul or a tune-up, it is necessary that your shop be equipped with proper tools, equipment and mechanics who are thoroughly familiar with Briggs & Stratton engine design and construction. With your shop thus equipped, this book will serve as a guide in performing the various steps necessary to do a complete and satisfactory job.

In order to keep all tables as simple as possible, only the basic engine models are listed unless there is a difference between them and special models.

To make inspection of parts simple and accurate only the sizes at which they should be rejected are shown. This eliminates the necessity for figuring allowances for wear, etc. If a part is worn larger (inside dimension such as magneto bearing) or smaller (such as crankshaft journal surfaces) than the given sizes, they should be rejected and replaced with new parts.

You will find special repair parts, valve guides, valve seat inserts, etc., are not listed in the regular Parts Lists and part numbers will be found only in this book or MS-4750.

The term "Inspect", "Check", "Test" and "Replace" are used as follows:

INSPECT — Visual inspection, look for signs of wear, scoring, cracks, stripped threads, etc.

CHECK — Measure by means of plug gauges, feeler gauges, micrometer, scale, etc.

TEST — Analyze with proper testing equipment.

REPLACE — This usually means to take off the old part and reassemble it or replace with a new one.

Illustrations do not necessarily designate a particular model, and should only be used to identify repair procedures.

TABLE OF CONTENTS

GENERAL INFORMATION	Section 1
IGNITION	Section 2
CARBURETION	Section 3
GOVERNOR CONTROLS and CARBURETOR LINKAGE	Section 4
GOVERNORS	Section 5
COMPRESSION	Section 6
STARTERS and CHARGING SYSTEMS	Section 7
LUBRICATION	Section 8
PISTONS, RINGS, RODS	Section 9
CRANKSHAFTS and CAM GEARS	Section 10
CYLINDERS and BEARINGS	Section 11
MUFFLER	Section 12
TOOLS	Section 13

1

2

3

4

5

6

7

8

9

10

11

12

13

COMMON SPECIFICATIONS FOR TWIN CYLINDER ENGINES

MODEL SERIES 401400 and 401700

Spark Plug Gap030"
Breaker Point Gap020"
Crankshaft End Play002" - .008"
Governed Idle Speed Range	1400 R.P.M.*
Armature Air Gap010" - .014"
Valve Clearance (with springs installed)	Intake .005" - .007" Exhaust .007" - .009"
Valve Clearance (without springs installed)	Intake .007" - .009" Exhaust .009" - .011"
Crankshaft Reject Sizes	Mag Journal 1.376 Crankpins 1.622 P.T.O. Journal 1.376
Cylinder Bore STD.	3.4375 (Resize if worn .003" or more)
Ring Gap Reject Sizes	Top & Center Comp. - .035"
Ring Gap Reject Sizes	Oil Ring - .045"
Initial Carburetor Mixture Adjustment	Needle Valve 1½ Turn Idle Valve 1½ Turn
Adjust Carburetor Idle Speed Screw to 900 R.P.M.*	

TORQUE SPECIFICATIONS

Connecting Rod	190 In.-Lbs.
Cylinder Head	(Torque Staggered Sequence) 160 In.-Lbs.
Flywheel Nut	150 Ft. Lbs.
Spark Plug	200 In.-Lbs.
Starter Motor Mounting Bolts	160 In.-Lbs.
Base (4 Bolts) Model Series 401400	300 In.-Lbs. - 25 Ft. Lbs.
Sump (7 Bolts) Model Series 401700	160 In.-Lbs.
Crankcase Cover (7 Bolts) Model Series 401400	140 In.-Lbs.
Crankcase Cover (4 Bolts) Model Series 401700	300 In.-Lbs. - 25 Ft. Lbs.
Governor Lever Lock Nut	100 In.-Lbs.

*See Section 3, Page 6.

INDEX

	SECTION	PAGE
Air Cleaner		
Servicing	3	1, 2
Alternator		
Dual Circuit	7	7, 8
Tri-Circuit	7	9, 10, 11
Armature		
Air Gap	2	4
Bearings		
End Play	10	2
Breaker Box or Cover		
Removal and Installation	2	2, 3
Breaker Points Adjustment	2	3
Breaker Plunger		
Check and Replace	2	3
Breaker Shaft		
Remove and Install	2	3
Breather		
Checking and Installation	8	2, 3, 4
Carburetor		
Replacing Float Valve Seat	3	3
Flo-Jet Two Piece		
Adjustment	3	5
Fuel Pump	3	5
Repairs	3	3
Replacing Float Valve Seat	3	3
Carburetor Linkage & Controls	4	1 to 4
Coils (See Armature)		
Compression Checking	6	1
Condenser		
Testing and Installation	2	2
Connecting Rod	9	1, 2, 3
Contact Point (See Breaker Point)		
Controls, Governor & Carburetor	4	1 to 4
Crankcase Cover End-Play	10	2
Crankshaft		
End Play	10	2
Cylinder Head		
Assembly and Torque	6	1
Cylinder		
Bearings	11	3
Inspection	11	1
Resizing Bore	11	1, 2
Dipper or Slinger	8	4
Dipsticks	8	2
Engine Model System	1	5
Extended Oil Fill	8	2
Flywheel		
Remove and Replace	2	4
Torque	2	2
Fuel Recommendation	1	1
Fuel Pump	3	5

	SECTION	PAGE
Gear Reduction		
Lubrication	8	1
General Information	1	1 to 5
Governors		
Controls	4	1 to 4
Mechanical	5	1 to 4
Governed Speed Limits	5	1
	4	2, 3
Identification System (Engine)	1	5
Lubrication		
Recommendations and Capacity	8	1
Magneto (See Armature)		
Oil Recommendations and Capacity	8	1
Oil Seal	11	3
Oil Slinger or Dipper	8	4
Pin, Piston	9	1
Piston Rings	9	2
Remote Controls	4	1 to 4
Resizing Cylinder Bore	11	1, 2
Rings, Piston	9	2
Rod, Connecting	9	2, 3
Seals, Oil	11	3
Spark Plug	2	2
Springs, Valve	6	4
Starters		
Electric, Gear Drive 12 V	7	1 to 5
Tappet Clearance	6	4
Tools, Briggs & Stratton	13	1 to 6
Torque Table	Preface	II
Valves		
Checking and Installing Guides	6	3, 4, 5
Clearance	6	4
Refacing Seats	6	3
Remove and Install	6	2, 3, 4
Replacing Seats	6	6

INDEX OF TABLES

	TABLE NO.	SECTION	PAGE
Camgear or Shaft Reject Sizes	2	10	2
Common Specifications			II
Connecting Rod Reject Sizes	2	9	2
Crankshaft Reject Size	1	10	1
Cylinder Bearing Reject Size	2	11	2
Cylinder Bore Standard Size	1	11	1
Ignition Specifications	1	2	2
Piston Pin Reject Size	3	9	3
Ring Gap Reject Size	1	9	2
Valve Seat Inserts	2	6	7
Valve and Tappet Clearance	1	6	4
Valve Seat Insert Tools	3	6	7

Section 1

GENERAL INFORMATION

Briggs & Stratton twin cylinder engines are of the same basic 4 stroke cycle design used in automobiles, aircraft trucks and tractors. As the name indicates, there are four strokes to one complete power cycle:

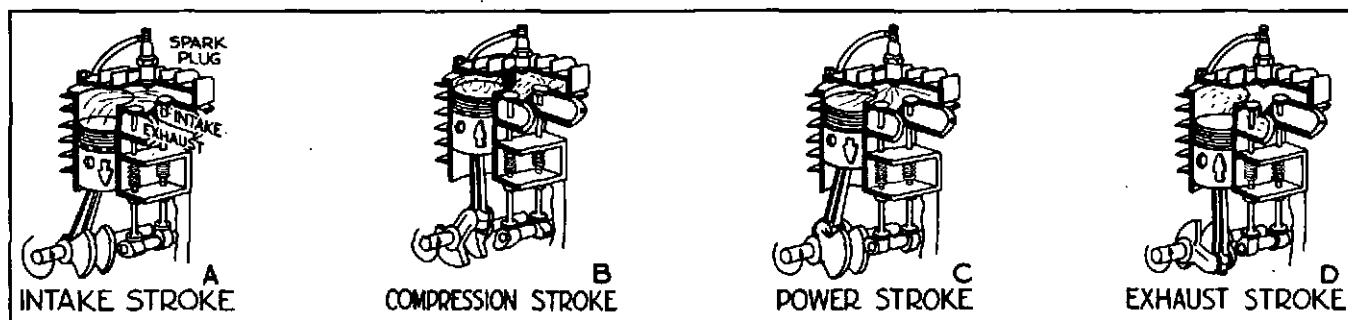

Fig. 1. The 4-Stroke Cycle

- a. **INTAKE STROKE:** The piston moves down, creating a vacuum in the cylinder which draws gas through open intake valve into the space above piston
- b. **COMPRESSION STROKE:** The piston moves up with both valves closed, highly compressing the gas into the space left between the top of the piston and cylinder head.
- c. **POWER STROKE:** At this point the magneto sends high voltage to the spark plug, firing or exploding the compressed gas and driving the piston down.
- d. **EXHAUST STROKE:** Exhaust valve opens and the upward stroke of the piston forces out all of the burnt gases, thus completing the power cycle.

CAUTION

Exhaust gases contain carbon monoxide which is odorless and a deadly poison. Proper care must be taken to provide efficient ventilation when running an engine indoors.

Fill the crankcase with proper oil before starting engine. See that oil level is maintained.

Do not fill the gasoline tank while the engine is running. Avoid spilling gasoline on a hot engine-This may cause an explosion and serious injury.

USE CLEAN GASOLINE

We recommend "regular, low-lead or lead-free" grade gasoline for all Briggs & Stratton engines. The use of lead-free, or low-lead gasolines will result in reduced combustion deposits.

We also recommend that gasoline be purchased in small quantities, not more than a 30-day supply. FRESH gasoline minimizes gum deposits, and also insures a fuel with volatility tailored for the season.

GENERAL INFORMATION

CORRECT LUBRICATION IS IMPORTANT

1

Any high quality detergent oil having the American Petroleum Institute classification "For Service SC, SD, SE or MS" can be used in Briggs & Stratton engines. Detergent oils keep the engine cleaner and retard the formation of gum and varnish deposits.

RECOMMENDED SAE VISCOSITY GRADES

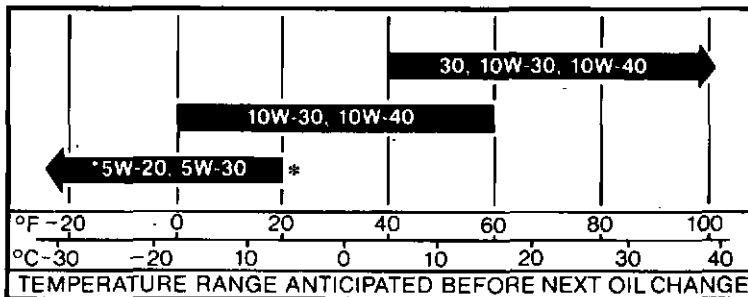

*If not available, a synthetic oil may be used having — 5W-20, 5W-30 or 5W-40 viscosity.

The oil recommendations are the result of extensive testing. No special additives should be used.

OIL SHOULD BE CHANGED AFTER EACH 25 HOURS OF ENGINE OPERATION. During normal engine operation, small particles of metal from the cylinder walls, pistons and bearings will gradually contaminate the oil. Dust particles from the air also contaminate the oil. If the oil is not changed regularly, these foreign particles cause increased friction and a grinding action which shortens the life of the engine. Fresh oil also assists in cooling, old oil gradually becomes thick and loses its cooling ability as well as its lubricating qualities.

The air cleaner should be serviced as outlined in section 3 page 1. Dirty operating conditions require more frequent servicing.

CLEAN COOLING SYSTEM

Grass particles, chaff or dirt may clog the air cooling system, especially after prolonged service in cutting dry grasses. Continued operation with a clogged cooling system may cause severe overheating and possible engine damage. The figure below shows the blower housing removed and area to be cleaned. This should be a regular maintenance operation.

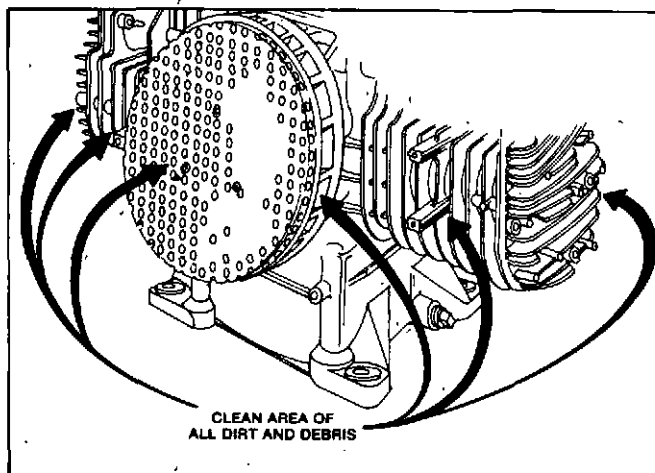

CHECK-UP

Most complaints concerning engine operation can be classified as one or a combination of the following:

1. Will not start
2. Hard starting
3. Lack of Power
5. Vibration
6. Overheating
7. High oil consumption

When the cause of malfunction is not readily apparent, perform a check of the Compression, Ignition and Carburetion Systems. This check-up, performed in a systematic manner, can usually be done in a matter of minutes. It is the quickest and surest method of determining the cause of failure. This check-up will point up possible cause of future failures, which can be corrected at the time. The basic check-up procedure is the same for all engine models, while any variation, by model will be shown under the subject heading.

NOTE: What appears to be an engine malfunction may be a fault of the powered equipment rather than the engine. If equipment is suspect, see Equipment, affecting engine operation.

Check Compression

Spin flywheel in reverse rotation (counterclockwise) to obtain accurate compression check. The flywheel should rebound sharply, indicating satisfactory compression. See section 6 page 1.

If compression is poor, look for —

1. Loose spark plug (s)
2. Loose cylinder head bolts
3. Blown head gaskets
4. Burnt valves and/or seats
5. Insufficient tappet clearance
6. Warped cylinder head (s)
7. Warped valve stems
8. Worn bore and/or rings
9. Broken connecting rods

Check Ignition

Remove the spark plug. Spin the flywheel rapidly with one end of the ignition cables clipped to the 19051 testers and with the other end of the testers grounded on the cylinder head. If spark jumps the .166" tester gaps, you may assume the ignition system is functioning satisfactorily. Try new spark plugs. See Sec. 2.

If spark does not occur look for—

1. Incorrect armature air gap
2. Sheared flywheel key
3. Incorrect breaker point gap
4. Dirty or burned breaker points
5. Breaker plunger stuck or worn
6. Shorted ground wire (when so equipped)
7. Shorted stop switch (when so equipped)
8. Condenser failure
9. Armature failure
10. Worn cam bearings and/or camshaft
11. Improperly operating interlock system

NOTE: If engine runs but misses during operation, a quick check to determine if ignition is or is not at fault can be made by inserting the 19051 testers between the ignition cable and the spark plugs. A spark miss will be readily apparent. See Sec. 2.

GENERAL INFORMATION

Check-up

Check Carburetion

1

Before making a carburetion check, be sure the fuel tank has an ample supply of fresh, clean gasoline. See that the shut-off valve is open and fuel flows freely through the fuel line. Inspect and adjust the needle valves. Check to see that the choke closes completely. If engine will not start, remove and inspect the spark plug. If plug is wet, look for —

1. Overchoking
2. Excessively rich fuel mixture
3. Water in fuel
4. Inlet valve stuck open

If plug is dry, look for—

1. Leaking carburetor mounting gaskets
2. Gummy or dirty carburetor
3. Inlet valve stuck shut
4. Inoperative fuel pump

A simple check to determine if the fuel is getting to the combustion chamber through the carburetor is to remove the spark plug and pour a small quantity of gasoline through the spark plug hole. Replace the plug. If the engine fires a few times and then stops, look for the same condition as for a dry plug.

Equipment - Effecting Engine Operation

Frequently, what appears to be a problem with engine operations, such as hard starting, vibration, etc., may be the fault of the equipment powered rather than the engine itself. Since many varied types of equipment are powered by Briggs and Stratton engines, it is not possible to list all of the various conditions that may exist. Listed are the most common effects of equipment problems, and what to look for as the most common cause.

Hard Starting, or Will Not Start

1. Loose belt—a loose belt like a loose blade can cause a back-lash effect, which will counter-act engine cranking effort.
2. Starting under load—See if the unit is disengaged when engine is started; or if engaged, does not have a heavy starting load.
3. Check remote control assembly for proper adjustment.
4. Check interlock system for shorted wires, loose or corroded connections, or defective modules or switches.

Vibration

1. Cutter blade bent or out of balance — Remove and balance.
2. Mounting bolts loose — Tighten.

Power Loss

1. Bind or drag in unit — If possible, disengage engine and operate unit manually to feel for any binding action.
2. Grass cuttings build-up under deck.
3. No lubrication in transmission or gear box.
4. Excessive drive belt tension may cause seizure.

Noise

1. Cutter blade coupling or pulley — an over-size or worn coupling can result in knocking, usually under acceleration. Check for fit, or tightness.
2. No lubricant in transmission or gear box.

BRIGGS & STRATTON NUMERICAL MODEL NUMBER SYSTEM

This handy chart explains the unique Briggs & Stratton numerical model designation system. It is possible to determine most of the important mechanical features of the engine by merely knowing the model number. Here is how it works:

- A. The first one or two digits indicate the CUBIC INCH DISPLACEMENT.
- B. The first digit after the displacement indicates BASIC DESIGN SERIES, relating to cylinder construction, ignition, general configuration, etc.
- C. The second digit after the displacement indicates POSITION OF CRANK-SHAFT and TYPE OF CARBURETOR.
- D. The third digit after the displacement indicates TYPE OF BEARINGS and whether or not the engine is equipped with REDUCTION GEAR or AUXILIARY DRIVE.
- E. The last digit indicates the TYPE OF STARTER.

<u>CUBIC INCH DISPLACEMENT</u>	<u>FIRST DIGIT AFTER DISPLACEMENT</u> BASIC DESIGN SERIES	<u>SECOND DIGIT AFTER DISPLACEMENT</u> CRANKSHAFT, CARBURETOR GOVERNOR	<u>THIRD DIGIT AFTER DISPLACEMENT</u> BEARINGS, REDUCTION GEARS & AUXILIARY DRIVES	<u>FOURTH DIGIT AFTER DISPLACEMENT</u> TYPE OF STARTER
6	0	0 -	0 - Plain Bearing	0 - Without Starter
8	1	1 - Horizontal Vacu-Jet	1 - Flange Mounting Plain Bearing	1 - Rope Starter
9	2			
10	3	2 - Horizontal Pulsa-Jet	2 - Ball Bearing	2 - Rewind Starter
11	4			
13	5	3 - Horizontal Flo-Jet	3 - Flange Mounting Ball Bearing	3 - Electric - 110 Volt, Gear Drive
14	6	4 - Horizontal Flo-Jet	4 -	4 - Elec. Starter- Generator - 12 Volt, Belt Drive
17	7			
19	8			
23	9			
24		5 - Vertical Vacu-Jet	5 - Gear Reduction (6 to 1)	5 - Electric Starter Only - 12 Volt, Gear Drive
25				
32				
40		6 -	6 - Gear Reduction (6 to 1) Reverse Rotation	6 - Alternator Only *
		7 - Vertical Flo-Jet	7 -	7 - Electric Starter, 12 Volt. Gear Drive, with Alternator
		8 -	8 - Auxiliary Drive Perpendicular to Crankshaft	8 - Vertical-pull Starter
		9 - Vertical Pulsa-Jet	9 - Auxiliary Drive Parallel to Crankshaft	

* Digit 6 formerly used for "Wind-Up" Starter on 60000, 80000 and 92000 Series

To identify Model 401417

<u>40</u>	<u>1</u>	<u>4</u>	<u>1</u>	<u>7</u>
40 Cubic Inch	Design Series 1	Horizontal Shaft - Flo-Jet Carburetor Mechanical Governor	Flange Mounting Plain Bearing	Electric Starter - 12 Volt Gear Drive with Alternator

Similarly, a Model 401707 is described as follows:

<u>40</u>	<u>1</u>	<u>7</u>	<u>0</u>	<u>7</u>
40 Cubic Inch	Design Series 1	Vertical Shaft - Flo-Jet Carburetor	Plain Bearing	Electric Starter 12 Volt Gear Drive with Alternator

Section 2 IGNITION

The twin cylinder engine uses a flywheel type magneto ignition system, having an external breaker. See Fig. 1.

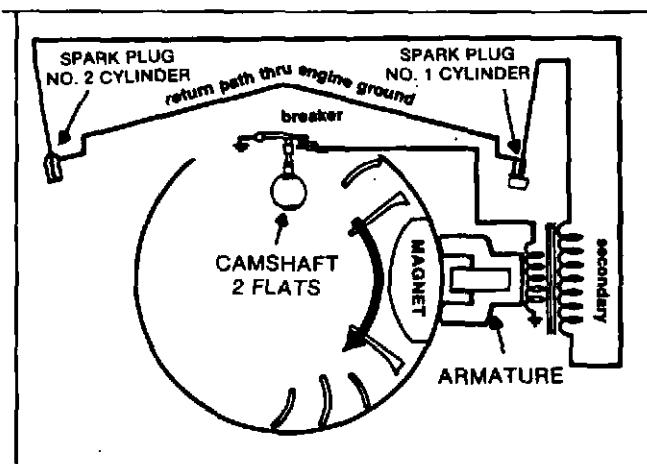

Figure 1. Ignition System

Check Ignition

Remove both spark plugs. Attach a 19051 tester to each spark plug lead and ground the other end of the testers as shown in Fig. 2. Spin the flywheel rapidly. If spark jumps the .166" tester gaps, you may assume the ignition system is functioning satisfactorily.

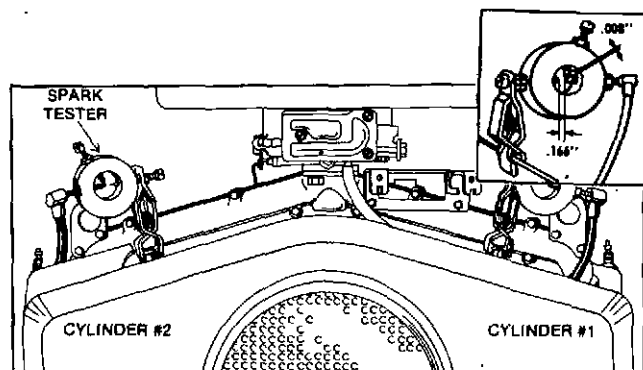

Figure 2. Checking Spark

If engine runs but misses during operation, a quick check to determine if ignition is or is not at fault can be made by inserting the 19051 tester between the ignition cable and the spark plug. A spark miss will be readily apparent. See Fig. 3.

NOTE: This test should be made with each cylinder. Tester gap should be .240" when making this test.

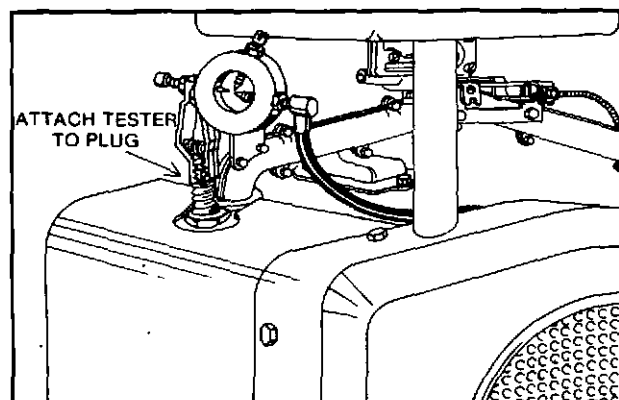

Figure 3. Running Check

To check for a fouled spark plug or a non-functioning cylinder, short one spark plug to ground and listen for speed drop. (engine should be running approximately 3000 R.P.M.) If speed change is not apparent when plug is shorted, the spark plug is fouled or the cylinder is not functioning. See Fig. 4.

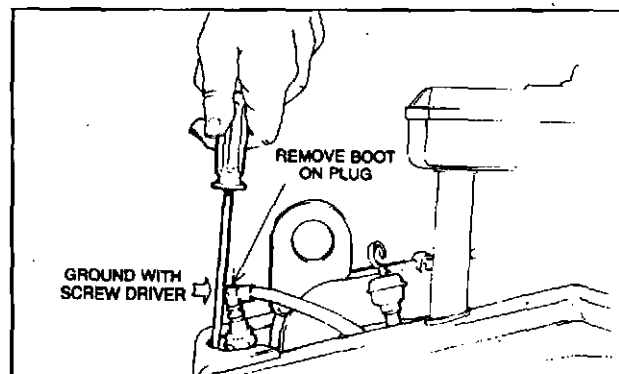

Figure 4. Checking Spark Plugs

IGNITION Specifications

2

TABLE NO. 1

SPECIFICATIONS FOR ALL TWIN CYLINDER ENGINE MODELS

1. Spark plug gap: .030
2. Condenser capacity: .18 to .24 M.F.D.
3. Contact point gap: .020

BASIC MODEL SERIES	ARMATURE AIR GAP	FLYWHEEL PULLER PART NO.	FLYWHEEL NUT TORQUE FT. LBS.
401400, 401700	.010 to .014	19203	150

SPARK PLUG

The spark plugs recommended for Briggs & Stratton twin cylinder engines are as follows:

	Manufacturer's Part No.
Champion	J-8
Auto-Lite	A-71
A.C.	GC-46

13/16" Plug wrench (deep socket)

IGNITION

The flywheel is located on the crankshaft with a soft metal key. It is held in place by a nut or starter clutch. The flywheel key must be in good condition to insure proper location of the flywheel for ignition timing. **DO NOT** use a steel key under any circumstances. Use only the soft metal key, as originally supplied.

The keyway in both flywheel and crankshaft should not be distorted.

REPLACE BREAKER POINTS-

NOTE: To service breaker points, first remove carburetor and intake manifold as outlined in Section 3 Page 2.

Turn crankshaft until points open widest gap. This makes it easier to assemble and adjust points later if crankshaft is not removed. Remove condenser and lower mounting screw. Loosen lock nut and back off breaker point screw. Fig. 6. Reverse process to install.

SPARK PLUG CLEANING

Clean spark plug with a pen knife or wire brush and solvent and set gap at .030" for all models. If electrodes are burned away, or the porcelain is cracked, replace with a new plug. **DO NOT USE ABRASIVE CLEANING MACHINES.** Fig. 5.

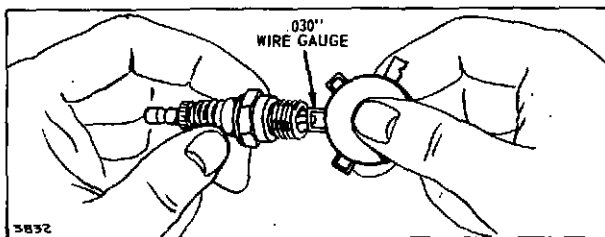

Figure 5. Adjusting Spark Plug Gap

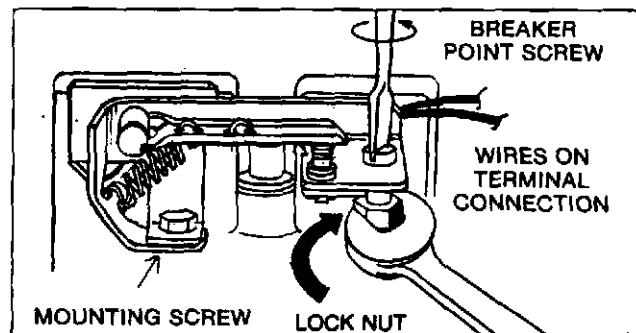

Figure 6. Breaker Points

COIL AND CONDENSER TESTING All Models

Use an approved tester to test coils and condensers. Specifications are supplied by the tester manufacturer.

To avoid the possibility of oil leaking past the breaker point plunger or moisture entering the crankcase between plunger and plunger hole, a plunger seal is used.

BREAKER POINT PLUNGER

If the breaker point plunger is worn to the length of 1.115, or less, it must be replaced. The breaker plunger must be inserted with the small diameter up, as shown in Fig. 7.

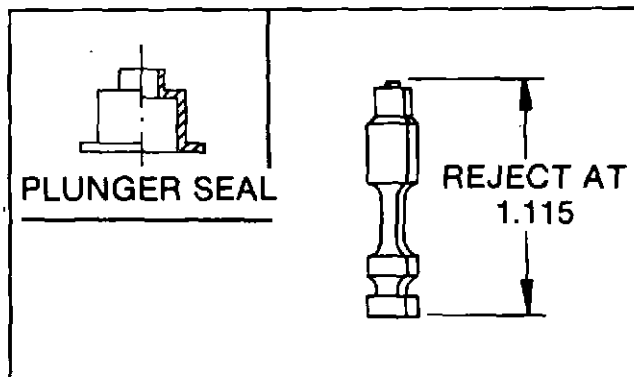

Figure 7. Checking Plunger

PLUNGER AND SEAL INSTALLATION

EXTREME CARE SHOULD BE TAKEN WHEN INSTALLING SEAL ON PLUNGER, OR SEAL MAY BE FRACTURED. DO NOT INSTALL A DAMAGED SEAL.

Install the rubber seal on the breaker plunger first. Make sure that it is attached securely and that the small diameter of the breaker plunger is up. Install the breaker plunger into the breaker plunger hole, and slide seal over plunger boss until edge comes in contact at the base. Fig. 8.

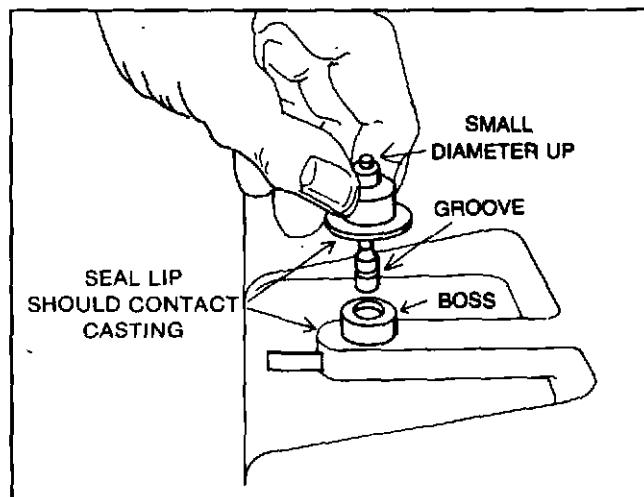

Figure 8. Installing Plunger and Seal

INSTALLING AND ADJUSTING BREAKER POINTS

Mount the breaker point assembly, as shown in Fig. 9.

Turn the crankshaft until the points open to their widest gap. Turn breaker point adjusting screw until points open to .020". NOTE: Feeler gauge must be parallel to point surfaces when making adjustment. Tighten locknut, Figure 6. To clean points turn the crankshaft until points are closed. Insert a piece of lintless paper and draw the paper between the points. Open the breaker points to withdraw the paper (so the paper will not tear and allow a small portion to remain between the points).

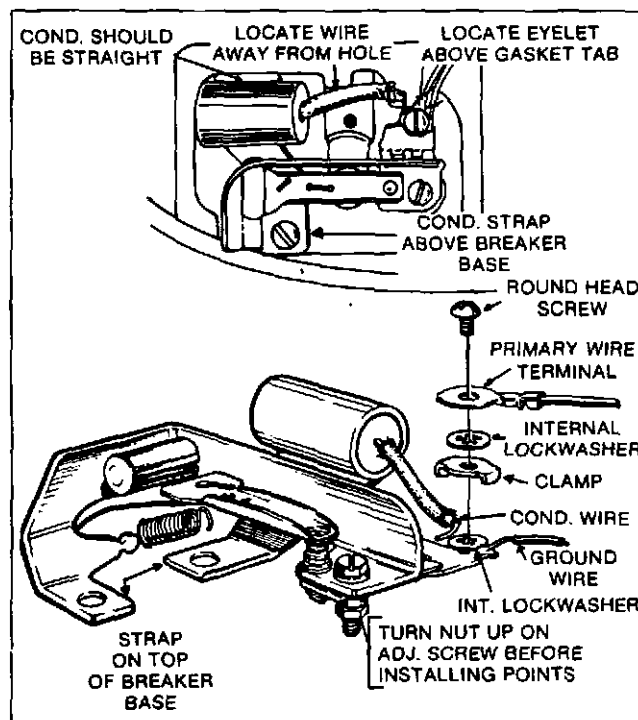

Figure 9. Installing Breaker Points

Apply additional sealer at the point at which the primary wire passes under the breaker cover. This area must be re-sealed to prevent the entry of dust and moisture. See Fig. 9A.

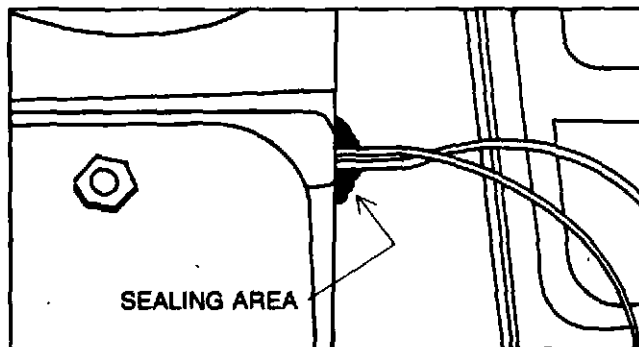

Figure 9A. Sealing Breaker Cover

IGNITION

REMOVE FLYWHEEL

To remove the flywheel use flywheel puller 19203. Before assembling the flywheel puller to flywheel, use the flywheel nut as a protective device for the threaded end of the crankshaft. Make sure that the flywheel nut is flush with the crankshaft threads. Run the bolts into the tapped holes of the flywheel evenly, continue to tighten until the flywheel loosens. Fig. 10.

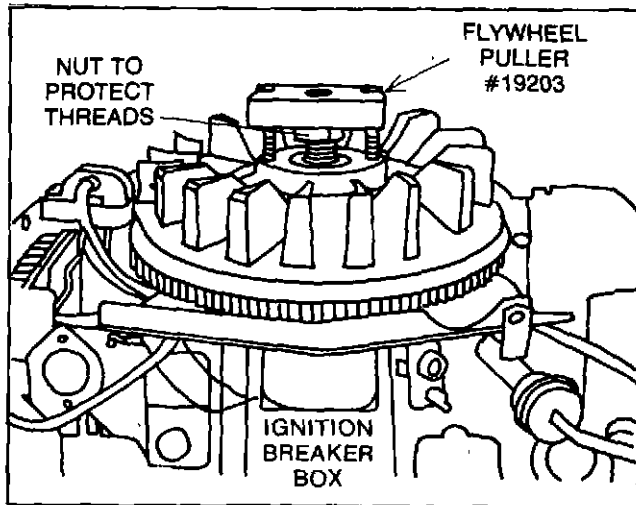

Figure 10. Removing Flywheel

INSTALL FLYWHEEL

Remove all oil or grease, clean flywheel taper and tapered end of the crankshaft before assembling flywheel to shaft. Insert the key into the keyway. Install screen cup first. Slip spring washer over crankshaft with the hollow side toward flywheel. See Fig. 11. Torque the flywheel nut to Specifications listed.

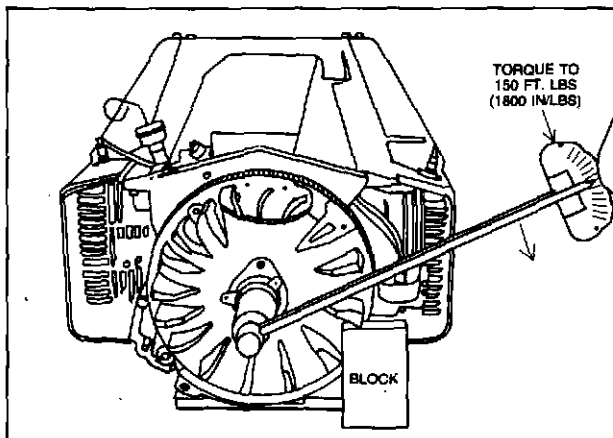

Figure 11. Torquing Flywheel

ADJUST ARMATURE AIR GAP

Set air gap between the flywheel and armature as stated in Table 1. Move armature away from flywheel as far as possible, tighten one screw, and slip the proper gauge between armature and flywheel. Fig. 12. Turn flywheel until magnets are directly below the armature. Loosen the one mounting screw and the magnets should pull the armature down firmly against the thickness gauge. Then tighten the mounting screws.

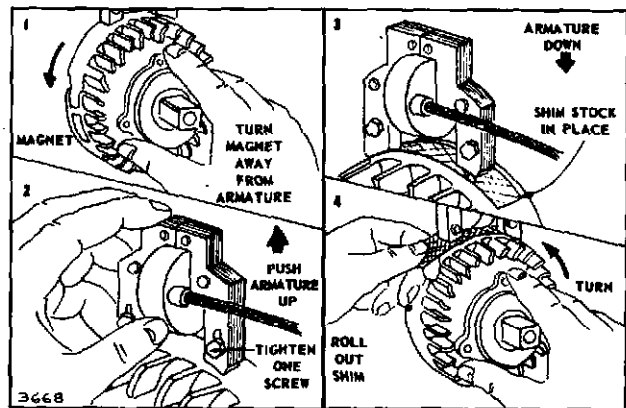

Figure 12. Adjusting Armature Air Gap

After installing the armature and setting the air gap, re-route the ignition cables as shown in Fig. 13. Make sure the ground wire and ignition cables are routed through the recess in the breather plate. Fig. 13.

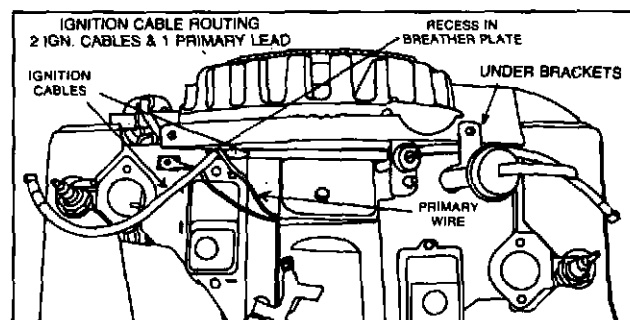

Figure 13. Routing Wiring

Section 3 CARBURETION

AIR CLEANERS

A properly serviced air cleaner protects the internal parts of the engine from dust particles in the air. If the air cleaner instructions are not carefully followed, the dirt and dust which should be collected in the cleaner, will be drawn into the engine and become a part of the oil film. Dirt in the oil forms an abrasive mixture which wears the moving parts, instead of protecting them. No engine can stand up under the grinding action which takes place when this occurs. The air cleaner on every engine brought in for a check up or repair should be examined and serviced. If the cleaner shows signs of neglect, show it to the customer before cleaning, and instruct him on proper care to assure long engine life.

NOTE: Replace air cleaner gaskets and mounting gaskets that are worn or damaged, to prevent dirt and dust entering engine through improper sealing. Straighten or replace bent mounting bracket.

SERVICING DUAL ELEMENT AIR CLEANER

Clean and re-oil foam pre-cleaner at 3 month intervals or every 25 hours, whichever occurs first. Fig. 1 or 2.

1. Remove wing nut and cover.
2. Remove foam pre-cleaner element by sliding it up off of the paper cartridge.
3. A—Wash foam in liquid detergent and water.
B—Squeeze dry.
C—Oil with one ounce engine oil. Squeeze to distribute oil evenly.
4. Assemble to paper cartridge. Reassemble cover and wing nut. Screw wing nut down tight.

Yearly or every 100 hours, whichever occurs first, remove paper cartridge. Clean by tapping gently on flat surface. If very dirty, replace cartridge, or wash in liquid detergent and water. Rinse until water remains clear. Cartridge must be air dried thoroughly before using. Do not use pressurized air.

NOTE: Service more often under dusty conditions.

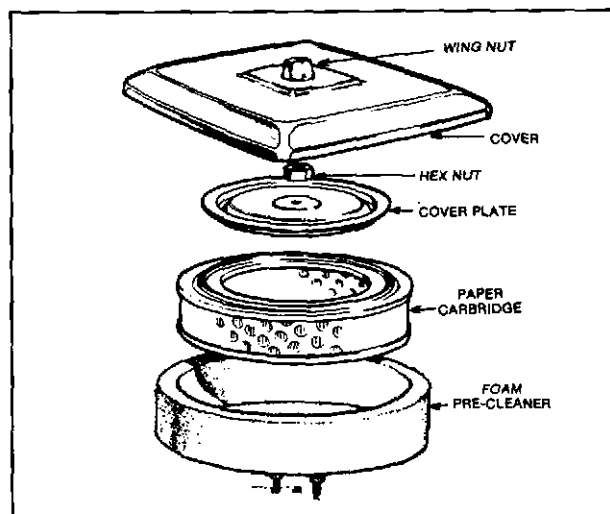

Fig. 1. Air Cleaner Assembly Model 401400

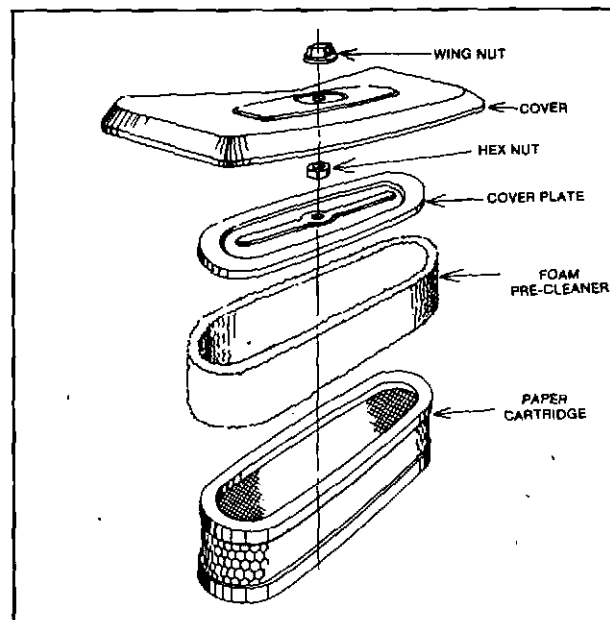

Fig. 2. Air Cleaner Assembly Model 401700

CAUTION: Petroleum solvents are not to be used to clean cartridge. They may cause deterioration of the cartridge. **DO NOT OIL CARTRIDGE.**

CARBURETION

Two Piece Flo-Jet

Briggs & Stratton twin cylinder engines models 401400 and 401700 use a two piece flo-jet down draft type of carburetor. This carburetor incorporates a high speed fuel circuit and a separate idle speed fuel circuit. An integral pulse type fuel pump allows remote fuel tank installations. The fuel pump will prime at an 18" maximum lift. See Fig. 3.

3

NOTE: Carburetor mixture adjustment procedures are not similar to single cylinder engines. The procedure outlined under "Adjustments" must be followed to insure proper engine performance.

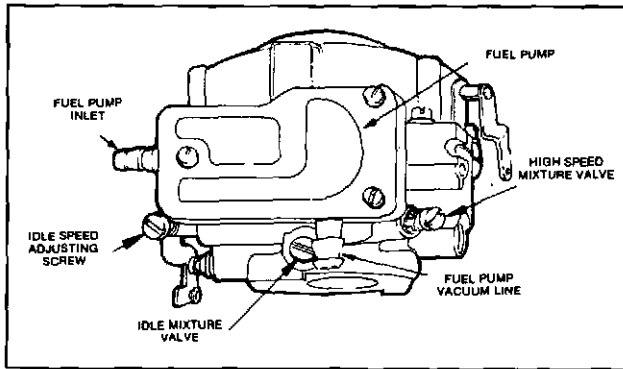

Fig. 3. Carburetor Assembly

REMOVING CARBURETOR

Model Series 401400

To remove the carburetor, the intake manifold and carburetor are removed as an assembly. Disconnect the fuel line and vacuum line from the pump. Use care to prevent breaking the plastic nipple. Remove the four screws that hold the intake manifold to the engine. **NOTE:** The intake manifold is epoxy sealed. Do not attempt to disassemble manifold.

Disconnect the governor spring from the governor lever, as shown in Fig. 4. Note the specific hole through which the spring was connected.

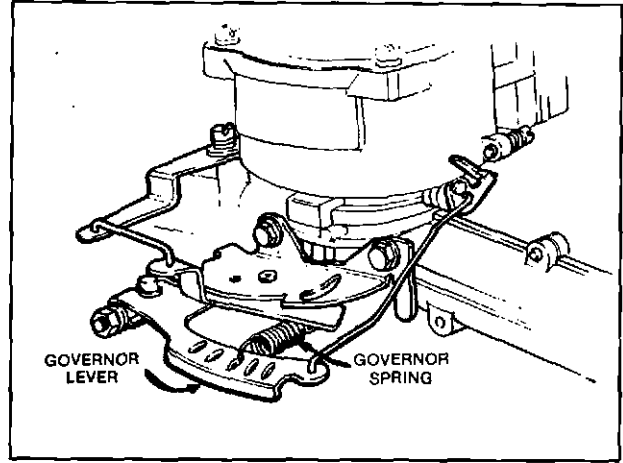

Fig. 4. Removing Governor Spring

Next, disconnect the governed idle spring, as shown in Fig. 5.

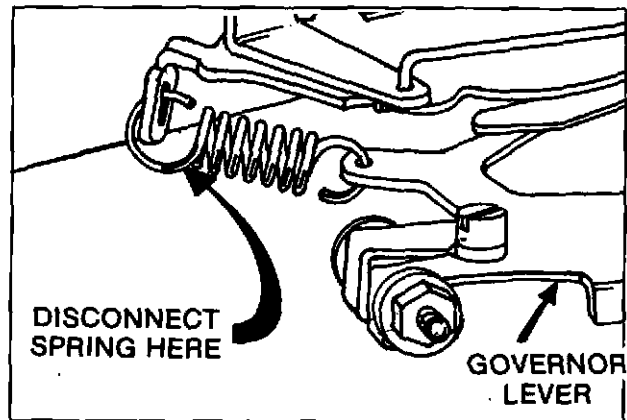

Fig. 5. Disconnect Governed Idle Spring

Disconnect the vacuum hose from the fitting at the fuel pump. Next, disconnect governor link from governor lever, as the carburetor and manifold assembly is lifted away from the engine. See Fig. 6. Use care to prevent bending link.

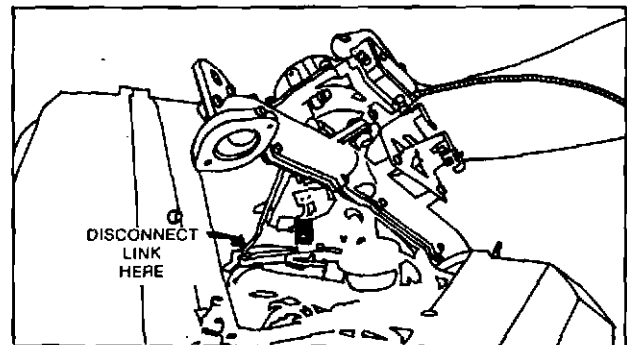

Fig. 6. Removing Carburetor and Manifold Assembly

REMOVING CARBURETOR

Model Series 401700

To remove the carburetor, disconnect the fuel line from the pump, use care to prevent breaking the plastic nipple Fig. 7. Disconnect the vacuum hose from the fitting at the carburetor. Remove two (2) hex head screws at the carburetor flange and disconnect the linkage to the governor arm, being careful not to damage the throttle link. Lift the carburetor off the flange.

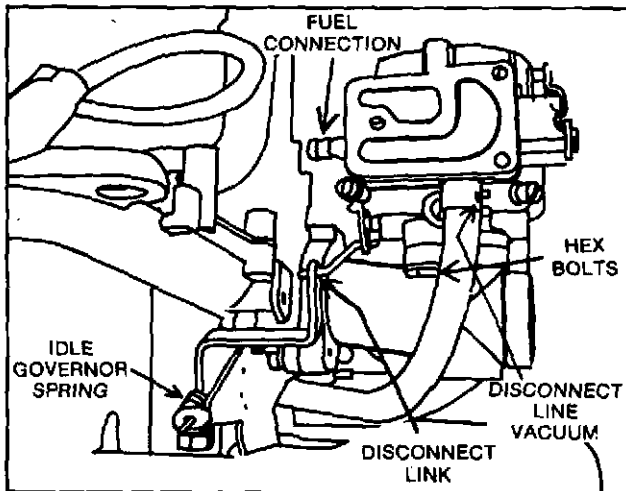

Fig. 7. Removing Carburetor Model 401700

DISASSEMBLE CARBURETOR

Remove idle and needle valves. Replace if damaged. Remove fuel pump body. See page 5. Remove upper carburetor body, See Fig. 8 float and float valve. Check float for leakage. Replace if damaged. Check float valve and seat. Replace if damaged or worn. If carburetor is extremely dirty, remove choke and throttle shafts and clean carburetor body in cleaner. Note: All rubber and foam seals and nylon parts should be removed before cleaning in solvent. See Fig. 8A.

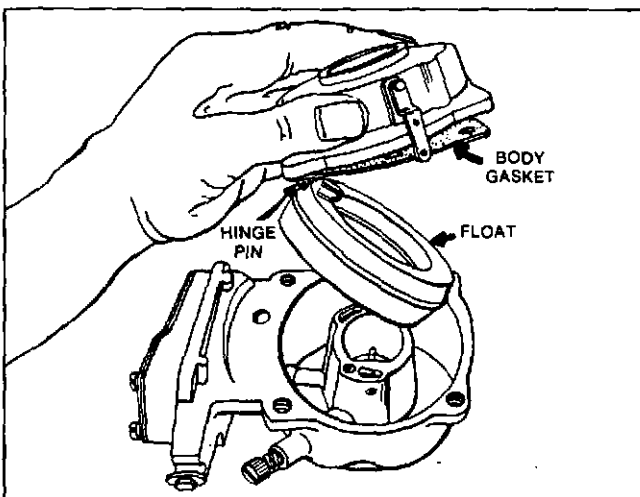

Fig. 8. Removing Upper Body

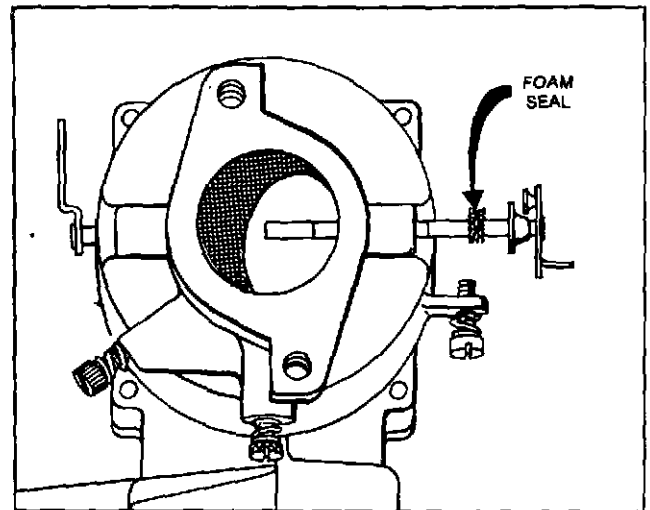

Fig. 8A. Removing Throttle Shaft Seal

REPAIR CARBURETOR

Use new parts where necessary. Always use new gaskets-old gaskets take a set or harden and may leak. Carburetor repair kits are available. The float valve has a spring clip which connects the float valve to the float tang.

A viton tip float valve is used in Flo-Jet carburetors. The seat is pressed in the upper carburetor body and does not need replacement unless damaged.

Replacing Pressed In Float Valve Seat

Use a 93029 self threading screw or remove one self threading screw from a 19069 flywheel puller and clamp head of screw in a vise. Turn carburetor body to thread screw into seat. Fig. 9. Continue turning carburetor body drawing seat out. Leave seat fastened to screw. Insert new seat, 231019 into carburetor body. (Seat has starting lead). See Figure 10.

CARBURETION

3

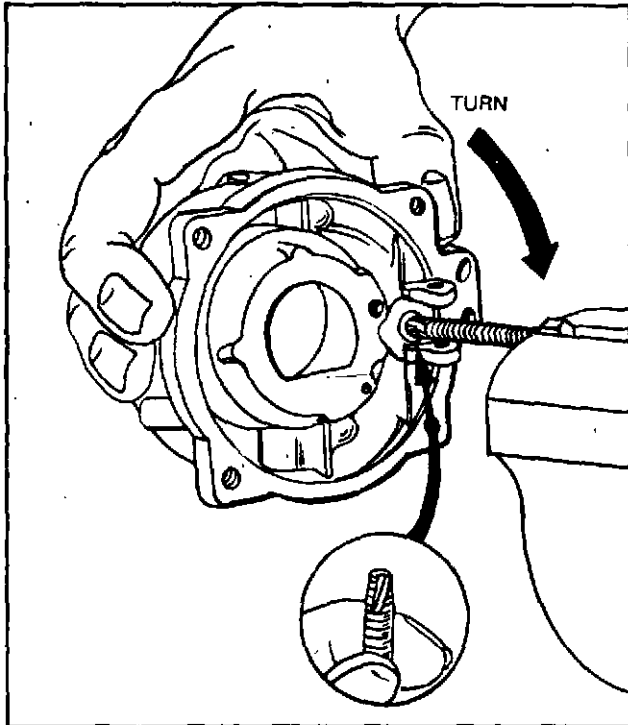

Fig. 9. Removing Float Valve Seat

Press new seat flush with body using screw and old seat as a driver. See Fig. 10. Use care to insure seat is not pressed below body surface or improper float to float valve contact will occur. Install float valve as shown in Fig. 11.

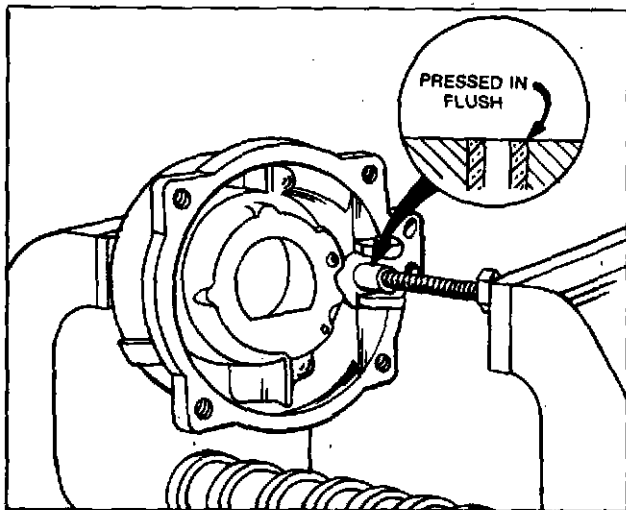

Fig. 10. Installing Float Valve Seat

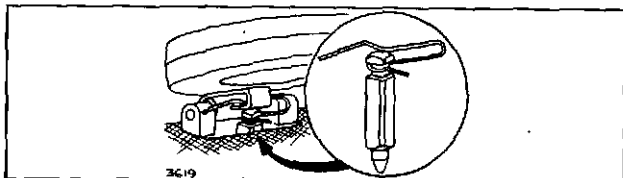

Fig. 11. Installing Float Valve

Checking Float Level

With body gasket in place on upper body see Fig. 12 and float valve and float installed, the float should be parallel to the body mounting surface. If not, bend tang on float until they are parallel. DO NOT PRESS ON FLOAT TO ADJUST. Fig. 12.

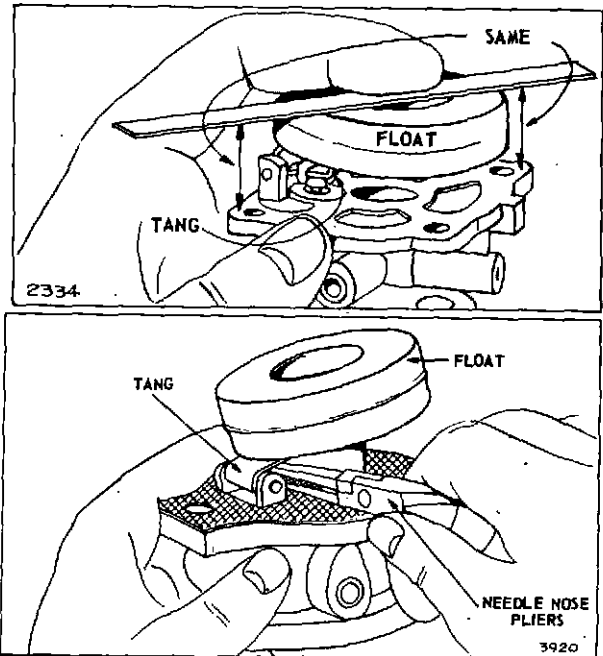

Fig. 12. Checking Float Level

ASSEMBLE CARBURETOR

Fasten upper and lower bodies together with the mounting screws.

NOTE: Holes in body gasket must align with body. See Fig. 13.

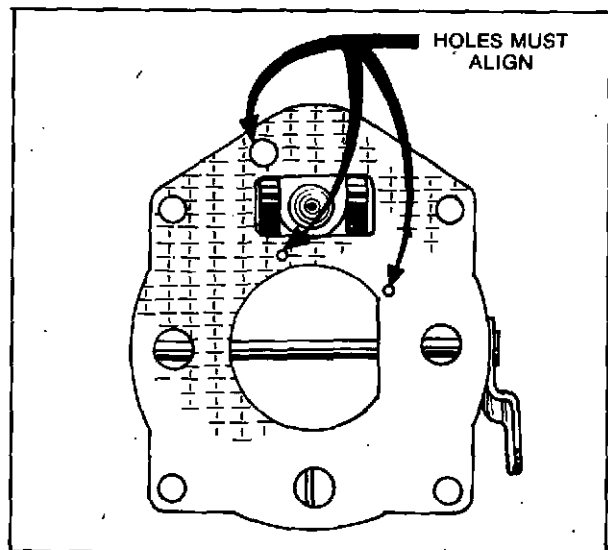

Fig. 13. Installing Body Gasket

If the choke shaft and choke plate are removed for servicing, make sure that the choke plate is reinstalled correctly. See Fig. 14. Tighten the two round head choke plate screws securely. (NOTE: DO NOT OVER TIGHTEN).

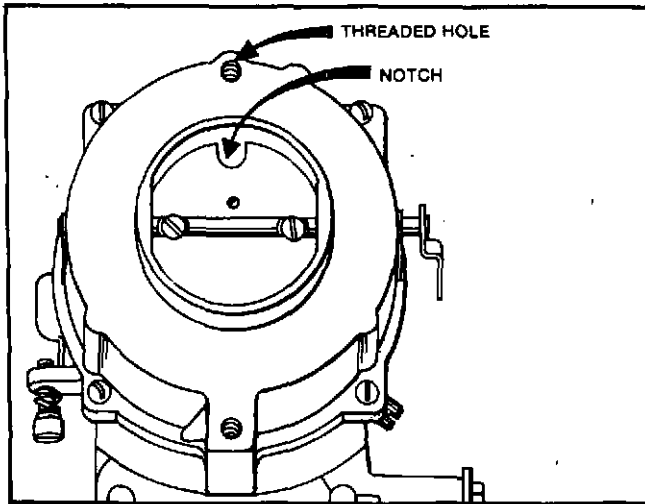

Fig. 14. Installing Choke Shaft and Plate

Screw in needle valve and idle valve until they just seat. Back off needle valve $1\frac{1}{2}$ turns. Back off idle valve $1\frac{1}{2}$ turns. These settings are approximately correct. Final adjustment will be made when engine is running. See Fig. 16.

FUEL PUMP

The integral fuel pump used in twin cylinder engines operates in conjunction with engine crankcase vacuum, similar to a pulsa-jet carburetor fuel pump. See exploded view Fig. 15.

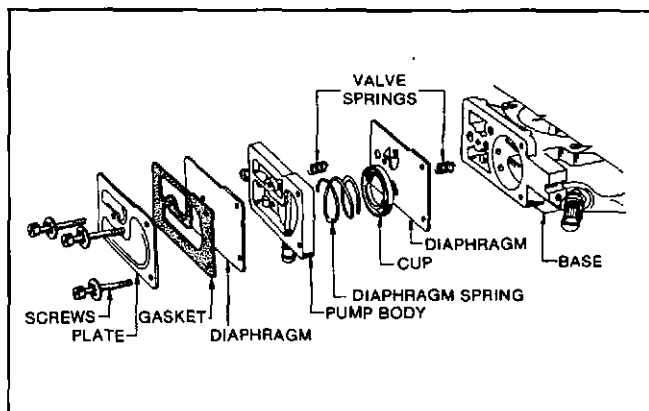

Fig. 15. Fuel Pump Assembly

To Replace Pump Diaphragms

Three screws are used to attach the pump to the carburetor. Remove screws and carefully lift off the pump body (plastic housing) to prevent damaging the diaphragm. Figure 15.

The diaphragm serves as a gasket between the carburetor and pump. Inspect diaphragm for punctures, wrinkles and wear. Replace if damaged. All diaphragm mounting surfaces must be free of nicks, burrs, and debris.

Inspect parts such as the pulse chamber spring and flapper valve springs for distortion or deterioration. Replace if necessary. Check outer pulse chamber diaphragm and cover plate gasket for cracks and punctures. Install new parts if found to be defective. Figure 15.

Assemble Fuel Pump

To assemble the pump to the carburetor, position the diaphragm on the carburetor. See Figure 15. Place the spring and protective cap on top of the diaphragm. Make sure that the flapper valve springs are installed at this time. Carefully place the pump body over the carburetor casting. Place the remaining diaphragm, gasket and cover plate over pump body and install the mounting screws. Tighten the screws in a staggered sequence to avoid distortion of the pump diaphragm.

NOTE: IF THE CARBURETOR IS NOT RECEIVING SUFFICIENT FUEL TO THE BOWL, INSPECT THE FUEL AND VACUUM LINES FOR LEAKAGE.

Carburetor Adjustment Procedure

Turn needle valve clockwise until it just closes. **CAUTION:** Valve may be damaged by turning it in too far. Now open needle valve $1\frac{1}{2}$ turns counterclockwise. Close idle valve in same manner and open $1\frac{1}{2}$ turns. This initial adjustment will permit the engine to be started and warmed up prior to final adjustment. See Fig. 16.

CARBURETION

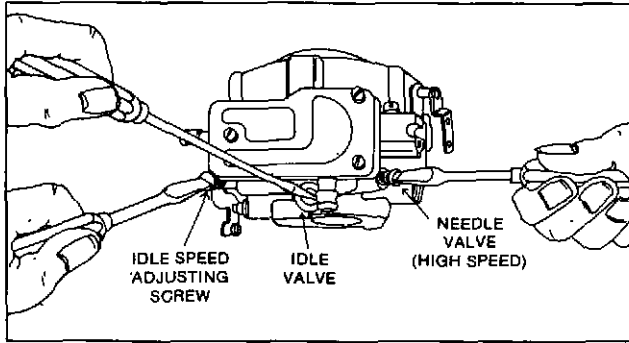

Fig. 16. Carburetor Adjustment

FINAL ADJUSTMENT

1. Place governor speed control lever in "IDLE" position. Hold throttle lever against idle stop and set idle speed adjusting screw to obtain 1400 R.P.M. Turn idle valve slowly clockwise (lean mixture) until engine misses or R.P.M. slows. Then turn idle valve $\frac{1}{2}$ turn counter-clockwise.
2. Hold throttle shaft in closed position and adjust idle speed screw to 900 R.P.M. Release the throttle. Move the remote control until a $\frac{1}{8}$ diameter pin can be inserted through two holes in the governor control plate, as shown in Fig. 17. This is the governed idle adjustment position.

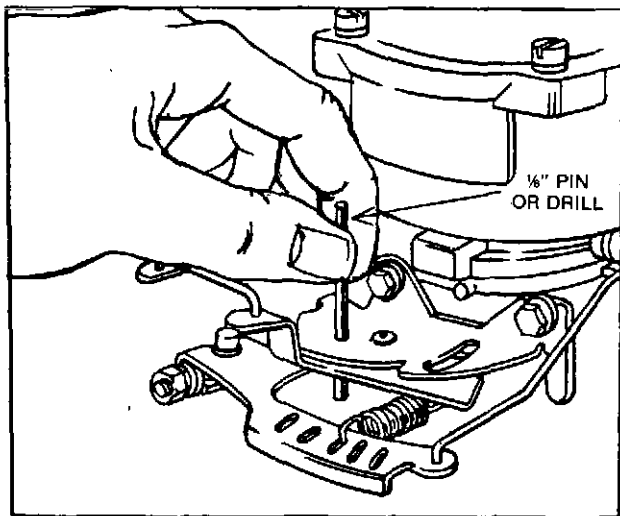

Fig. 17. Alignment of Governor Control Plate

With remote control in governed idle position, adjust tab "A" to obtain to 1400 R.P.M. See Fig. 18 and 19.

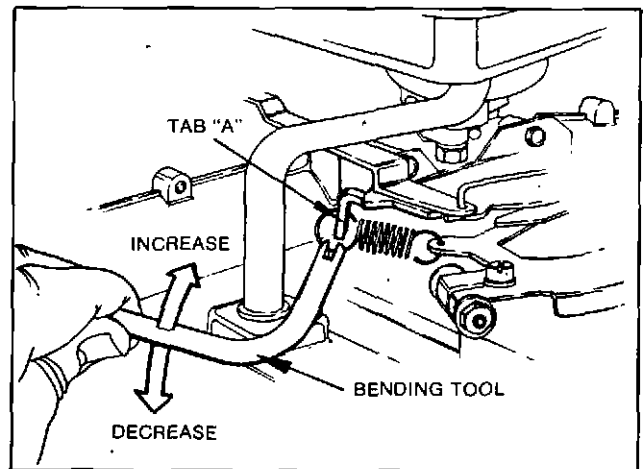

Fig. 18. Adjusting Governed Idle Spring Model Series 401400

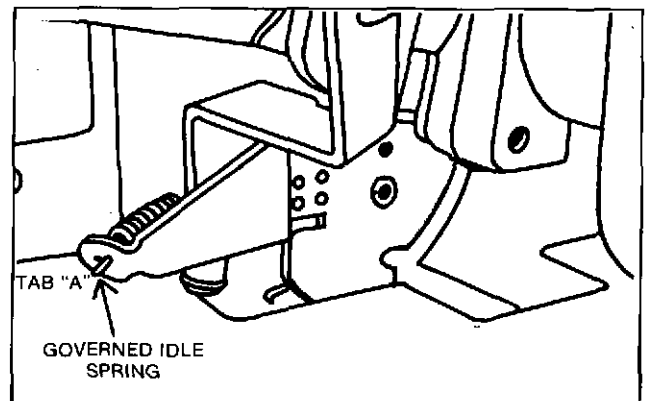

Fig. 19. Adjusting Governed Idle Spring Model Series 401700

NOTE: Governed idle must be adjusted correctly for proper operation. The smaller spring keeps the engine on governor, even at idle speed. If moderate loads are applied at idle, the engine will not stall. Governed idle speed should be no lower than 1100 R.P.M.

3. Place governor speed control lever in fast position. Then turn needle valve in slowly clockwise (lean) until engine misses or R.P.M. slows. Then turn needle valve $\frac{1}{2}$ turn counter-clockwise.

If engine does not accelerate properly, readjust needle valve approximately $\frac{1}{8}$ turn counterclockwise (richer).

Section 4

GOV. CONTROLS & CARB. LINKAGE

Twin cylinder engines are equipped with a governed idle system, which includes a manual throttle override for positive idle. Moving the remote control to full idle position defeats governed idle by mechanically forcing the throttle to a fully closed position. This manual override feature allows the equipment operator to prevent engine overspeeding in the event a governor failure occurred.

Proper remote control cable adjustment is required to insure the manual override system is functioning. Adjust remote control cable as follows:

1. Loosen remote control cable casing clamp at carburetor. See Fig. 1 or 2.
2. Place equipment remote control lever in full slow (idle) position.
3. Slide remote control cable casing backward or forward under casing clamp at carburetor, until governor speed control lever at carburetor is in full slow (idle) position. See Fig. 1 or 2.
4. Tighten casing clamp screw.

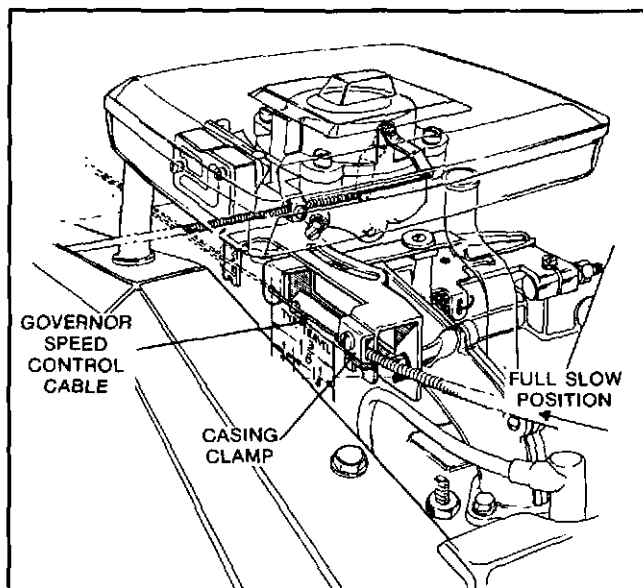

Fig. 1. Remote Control Adjustment Model Series 401400

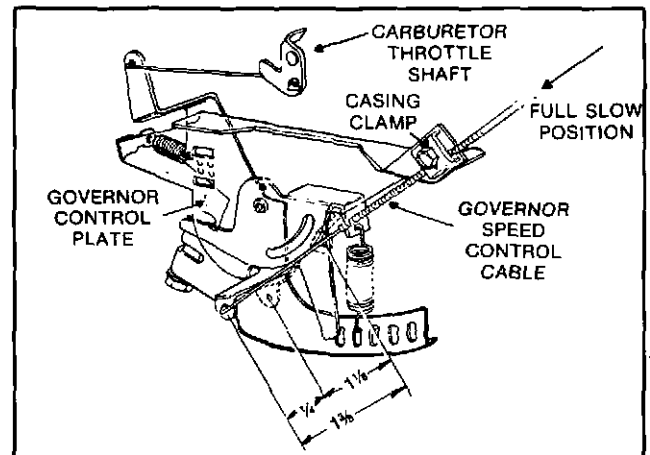

Fig. 2. Remote Control Adjustment Model Series 401700

REMOTE GOVERNOR CONTROL

The remote governor control regulates the engine speed by changing governor spring tension, thus allowing the governor to control the carburetor throttle at all times, and maintain desired speed. The remote control assembly is shown in Fig. 3.

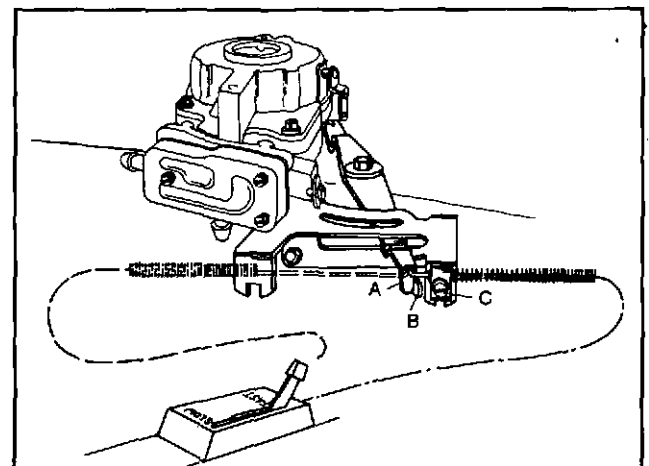

Fig. 3. Remote Governor Control

GOV. CONTROLS & CARB. LINKAGE

Engines which use a remote governor control are equipped with both a governor spring and a governed idle spring. The location of the springs is shown in Figures 4 through 7.

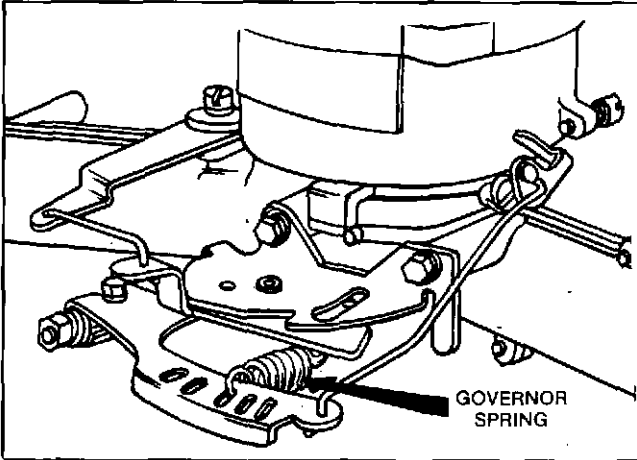

Fig. 4. Governor Spring Model Series 401400

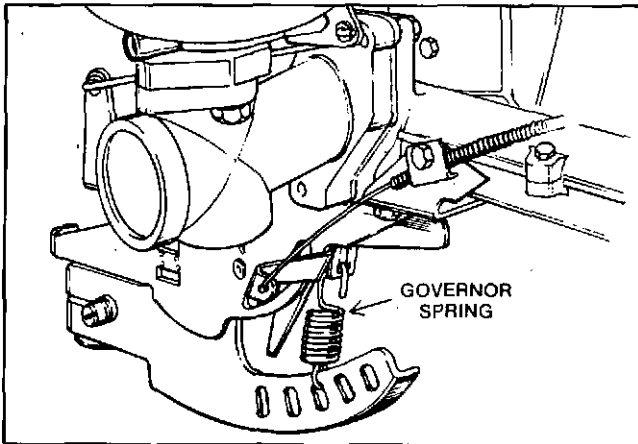

Fig. 5. Governor Spring Model Series 401700

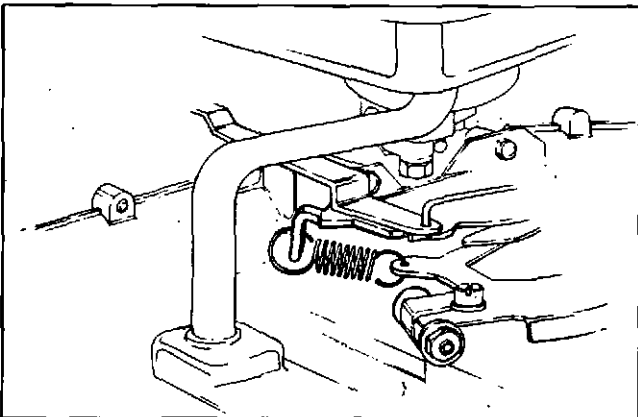

Fig. 6. Governed Idle Spring Model Series 401400

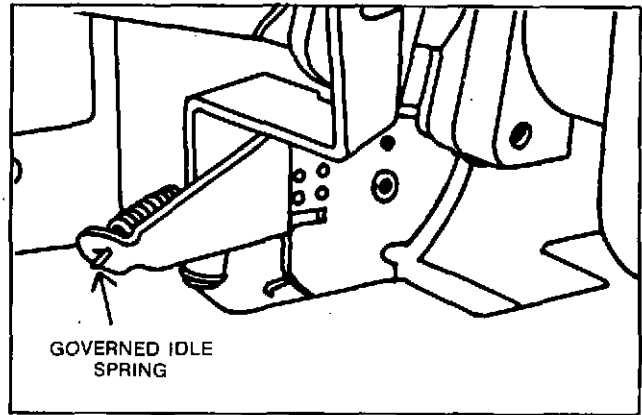

Fig. 7. Governed Idle Spring Model Series 401700

GOVERNED IDLE

Governed idle allows the governor to control the carburetor throttle at idle speeds. If moderate loads are applied at idle, the engine will not stall. On engines with governed idle, two governor springs are used. The smaller spring is the governed idle spring. See Figures 6 and 7.

ADJUSTING GOVERNED IDLE

First make final carburetor mixture adjustments. Next, hold the throttle shaft in the closed position and adjust the idle speed screw to 900 R.P.M. See Fig. 8.

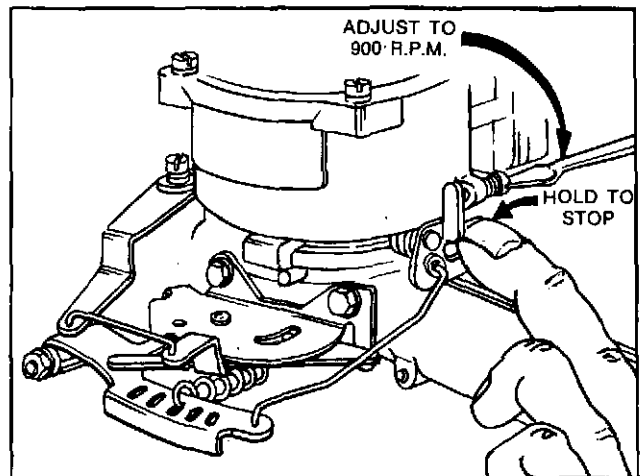

Fig. 8. Idle Speed Adjustment

Move the remote control toward the idle position until a 1/8 diameter pin can be inserted through two holes in the governor control plate, as shown in Fig. 9.

GOV. CONTROLS & CARB. LINKAGE

ADJUSTING TOP NO-LOAD SPEED

NOTE: Governed idle speed adjustment must be made before adjusting top no-load speed.

To adjust top no-load speed, first check to be sure governor spring is in the proper hole in the governor lever. See section 5, page 1. Next, move the remote governor control to the desired top no-load speed. Bend tang "A" until it just contacts the speed control lever as shown in Fig. 12 or Fig. 13.

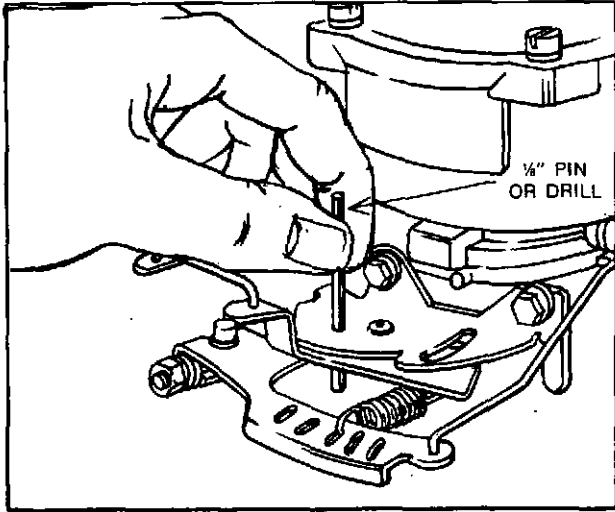

Fig. 9. Alignment of Governor Control Plate

With the remote governor control in the idle position, and the holes in the governor control plate aligned, bend tang as shown in Fig. 10 to obtain 1400 R.P.M.

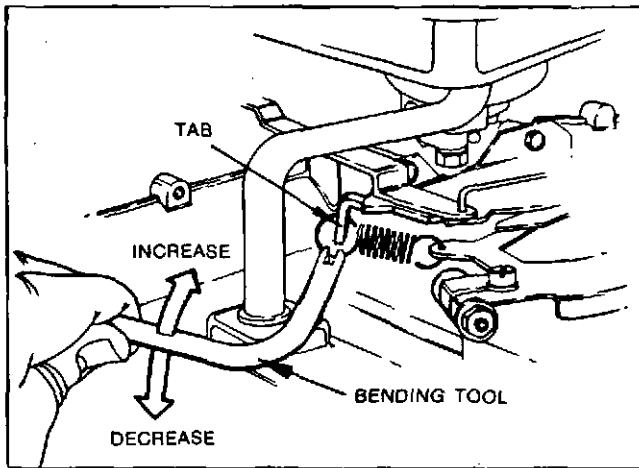

Fig. 10. Setting Governed Idle Speed

Use tool shown in Fig. 11 to bend spring anchor tang. This tool can easily be made out of 5/16 dia. cold rolled steel or ordered thru your Briggs & Stratton supplier as part number 19229.

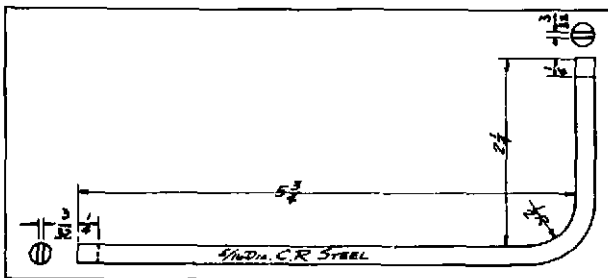

Fig. 11. Tang Bending Tool

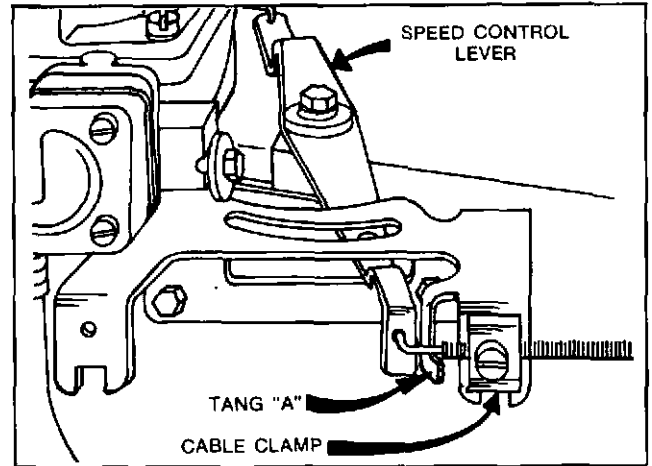

Fig. 12. Adjusting Top No-Load Speed Model Series 401400

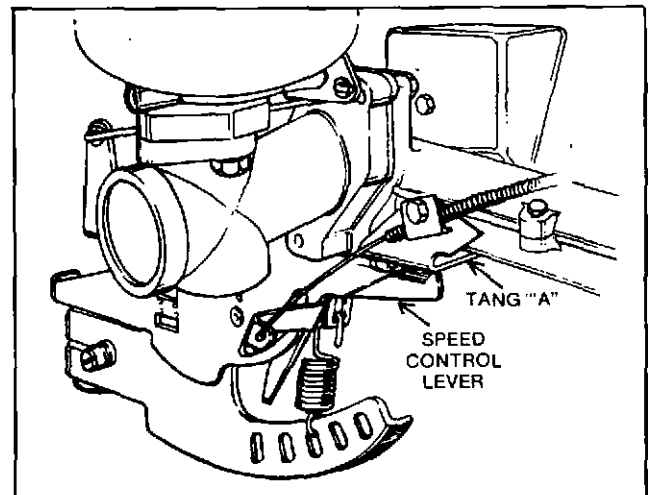

Fig. 13. Adjusting Top No-Load Speed Model Series 401700

When speed control lever is just touching tang "A", the remote control lever should be in the FAST position. Loosen cable clamp to adjust if necessary. See Fig. 12 or Fig. 13.

GOV. CONTROLS & CARB. LINKAGE

CHOKE ADJUSTMENT

Proper choke operation is dependent upon the correct adjustment of the remote choke control on the equipment. Travel of remote control wire must be a minimum of 1-3/8" in order to achieve full "CHOKE" position. Fig. 14.

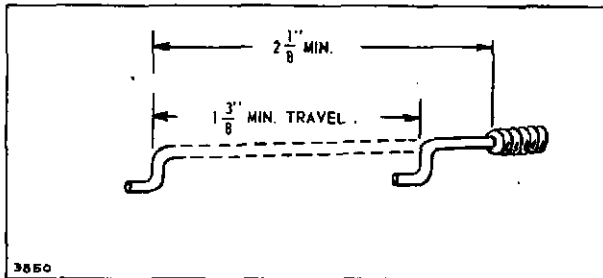

Fig. 14. Remote Choke Travel

To Adjust Choke: Place choke control lever on equipment in the full choke position. Loosen the control casing clamp screw. Move control casing and wire until choke is completely closed, as shown in Fig. 15.

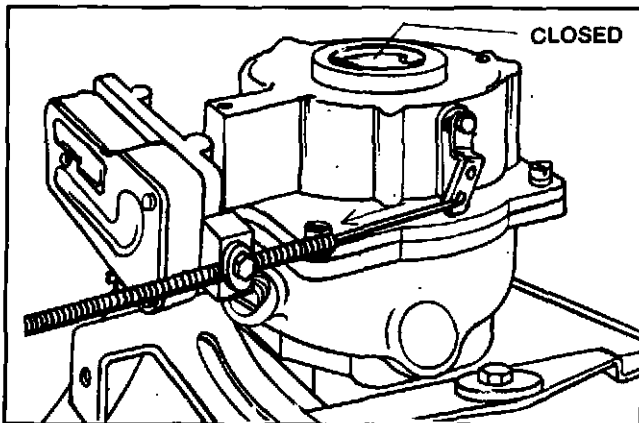

Fig. 15. Choke Valve Closed

Tighten casing clamp. Move lever to open position and check to make sure choke valve is at wide open position, as shown in Fig. 16.

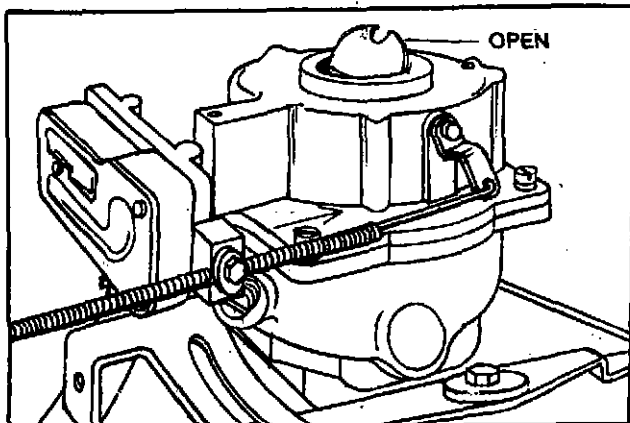

Fig. 16. Choke Valve Open

FIXED SPEED GOVERNOR CONTROL

On engines which operate at a fixed speed, the speed control lever is locked to the governor control plate with a self tapping screw.

ADJUSTING FIXED SPEED CONTROL

To adjust fixed speed control, loosen screw, then move the speed adjusting lever to the desired top no-load speed. Tighten screw. See Fig. 17 or 18.

Bend tang "A" until it just contacts the lever.

NOTE: Proper governor spring position must be selected to obtain desired speed. See section 5, page 1, Figures 1 and 2.

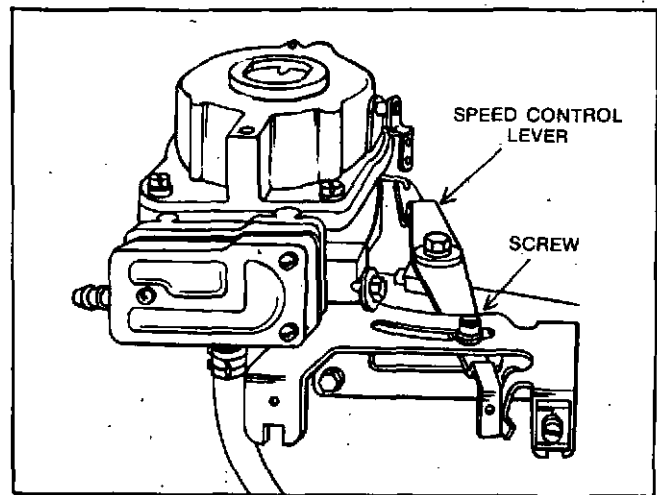

Fig. 17. Adjusting Fixed Speed — Model Series 401400

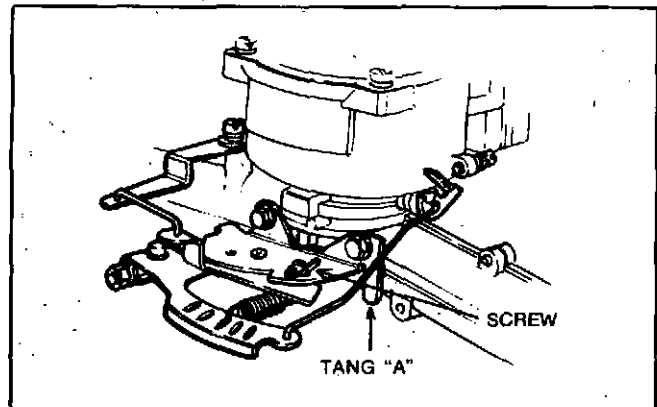

Fig. 18. Adjusting Fixed Speed — Model Series 401400

Section 5

GOVERNORS

THE PURPOSE OF THE GOVERNOR IS TO MAINTAIN WITHIN CERTAIN LIMITS, A DESIRED ENGINE SPEED, EVEN THOUGH THE LOAD MAY VARY.

MECHANICAL GOVERNOR

The governor spring tends to pull the throttle open. The force of the counterweights, which are operated by centrifugal force, tends to close the throttle. The engine speed at which these two forces balance is called the governed speed. The governed speed can be varied by changing governor springs tension. See Fig. 1 and Fig. 2.

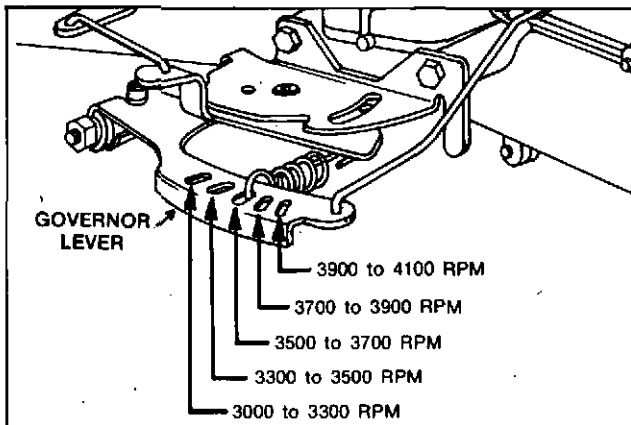

Fig. 1. Governor Spring Positions Model Series 401400

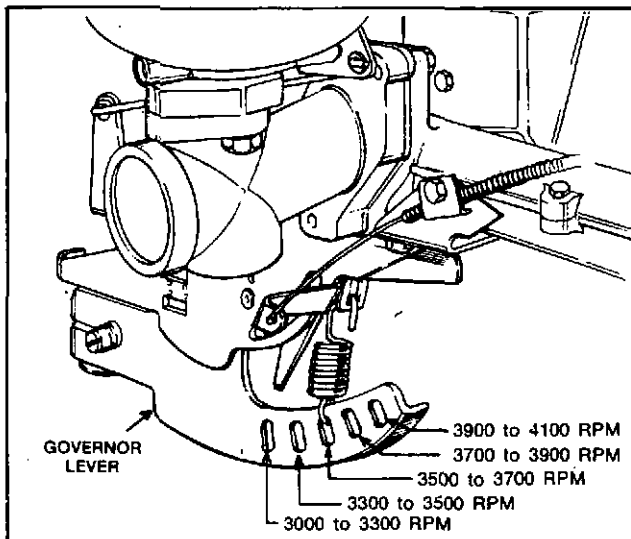

Fig. 2. Governor Spring Positions Model Series 401700

To comply with specific top governed speed limits, Briggs & Stratton supplies manufacturers with engines having an adjustable top speed limit, which is set to equipment manufacturers specifications.

The top speed limit will allow no more than the desired top governed speed, when the engine is operated on a rigid test stand at our own factory. However, the design of the equipment used, can affect engines speeds, therefore, the top governed speed should be checked with a tachometer when the engine is operating on a completely assembled unit. The equipment should be operated at no load when making these checks.

If a governor spring must be replaced, consult the appropriate Illustrated Parts List. Choose the proper governor spring by engine type number.

AFTER A NEW GOVERNOR SPRING IS INSTALLED, CHECK ENGINE TOP GOVERNED SPEED WITH AN ACCURATE TACHOMETER.

ADJUSTING TOP GOVERNED SPEED

Use recommendations as shown in Figures 1 and 2. If governing is unstable, first check carburetor mixture adjustments, then check governed idle adjustment. See section 4, page 2. If governing remains unstable, move governor spring to next higher speed range and re-adjust top no-load speed. See section 4, page 3.

NOTE: Governor springs should be installed so end loops are positioned as shown in figures 1 and 2.

GOVERNORS

Repair & Adjustment

GOVERNOR REPAIR AND ADJUSTMENT

To repair the governor mechanism on the horizontal or vertical crankshaft engine, it is necessary to remove the crankcase cover or sump. Drain oil before disassembling. To help remove cover or sump, rotate the crankshaft so it will leave the number one cylinder intake valve at its maximum opening. This relieves side pressure on the camshaft bearing. Remove number one spark plug and check to see if the valve is at maximum opening.

The governor assembly is identical on both the horizontal and vertical crankshaft engine. See Figures 3 and 4.

5

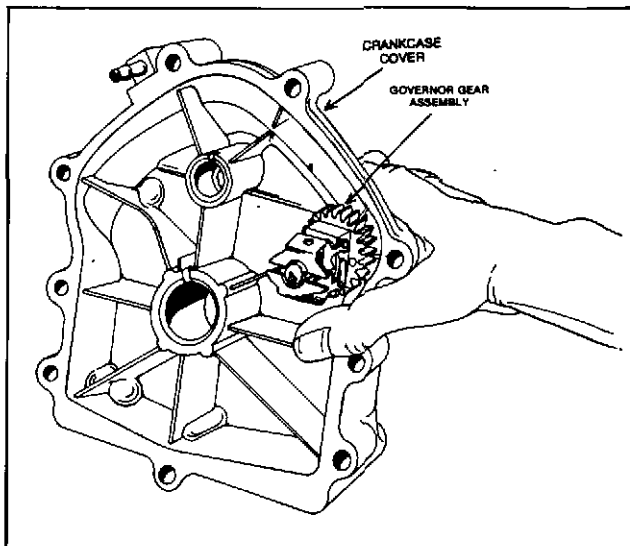

Fig. 3. Governor Gear Assembly Model Series 401400

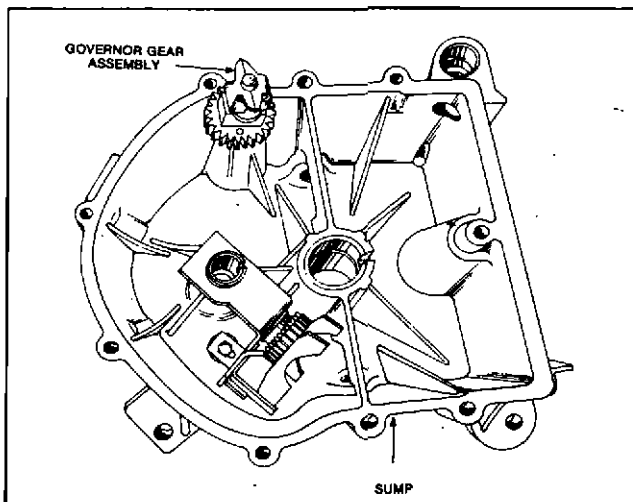

Fig. 4. Governor Gear Assembly Model Series 401700

NOTE: When removing the governor assembly from the crankcase cover or sump, note the location of the thrust washer. See Figure 5. The governor should be inspected for wear on gear teeth, pivot pins and weights. Also inspect the governor cup. Replace governor assembly if there is any indication of wear or damage on these parts. See Figure 6.

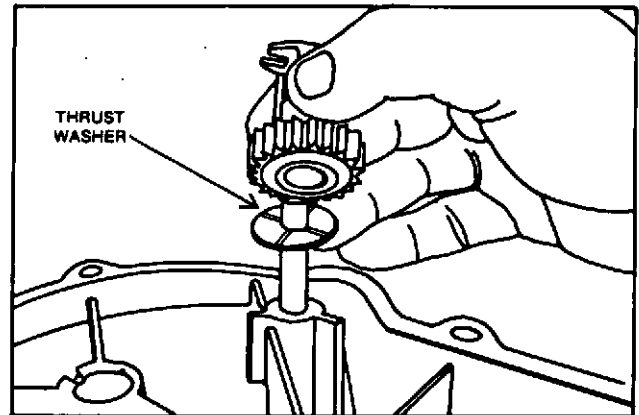

Fig. 5. Thrust Washer Location

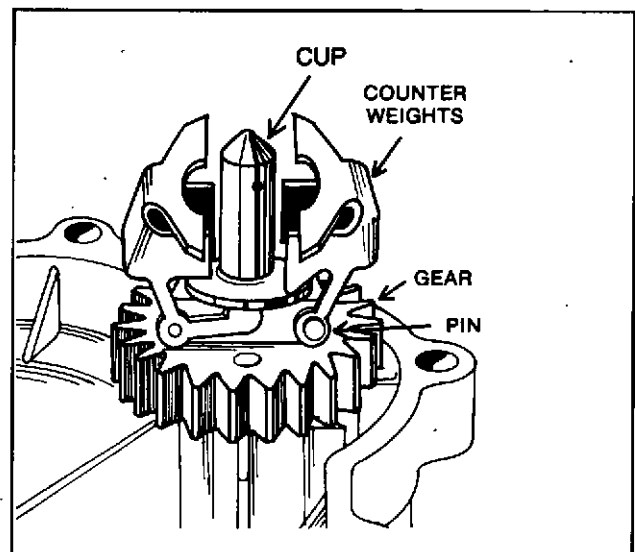

Fig. 6. Governor Gear Assembly

REMOVING GOVERNOR LEVER AND SHAFT

Loosen nut and remove the governor lever. Rotate the crankshaft to have the timing mark on the crankshaft gear at approximately the 10 O'clock position, as shown in Fig. 7. This is done so maximum clearance can be obtained to remove the governor shaft. Next, remove the "E" ring and thick washer located at the outer end of the governor shaft. The governor shaft will now slide down into the cylinder. If the governor shaft hits the crankshaft, lift the paddle of the governor shaft up slightly and rotate the crankshaft back and forth slightly to obtain additional clearance. See Fig. 8. **CAUTION:** Be careful not to bind the governor shaft against the crankshaft. If this occurs, it is possible to break or damage the lower support bearing for the governor shaft.

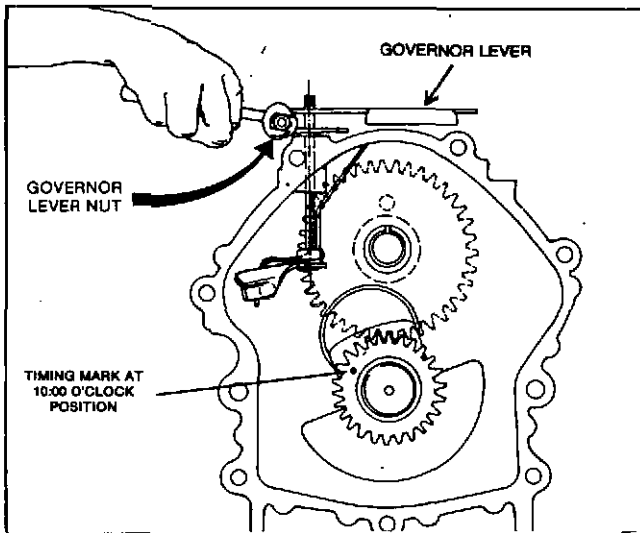

Fig. 7. Remove Governor Lever

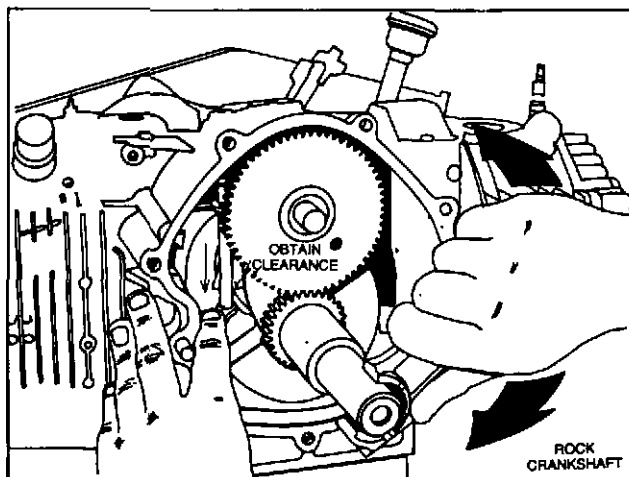

Fig. 8. Removing Governor Shaft

INSTALLING GOVERNOR SHAFT

Place the thin thrust washer on the governor shaft, before inserting shaft into the crankcase. With the crankshaft in the same position as in disassembly, slide the shaft up into position. Install the thick washer and secure shaft with the "E" ring. Place governor lever on the shaft and lightly tighten nut. **MAKE SURE GOVERNOR SHAFT IS IN THE PROPER POSITION BEFORE ASSEMBLING THE CRANKCASE COVER OR SUMP.** See Figure 9.

IF GOVERNOR SHAFT IS NOT IN CORRECT POSITION SHOWN, BEFORE ASSEMBLING THE CRANKCASE COVER, OR SUMP, PROPER GOVERNING ADJUSTMENT CANNOT BE OBTAINED.

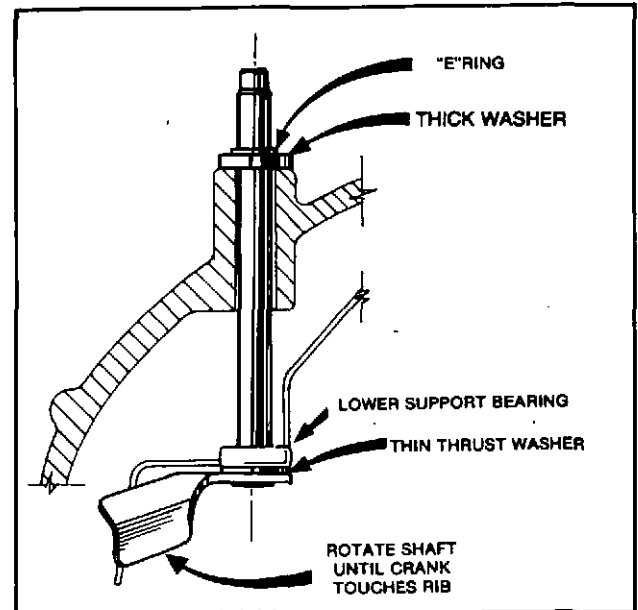

Fig. 9. Governor Shaft Assembly

INSTALLING GOVERNOR GEAR ASSEMBLY

Install the governor gear assembly and thrust washer on the shaft in the crankcase cover, or sump, as shown in Figure 10.

GOVERNORS

Repair & Adjustment

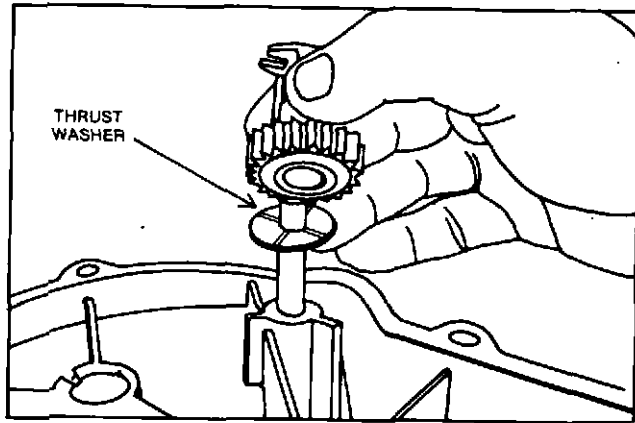

Fig. 10. Thrust Washer Location

5

Rotate the governor gear on the shaft to be sure it is free, and the weights and cup are in the proper location so that they will be able to move freely without binding.

INSTALLING CRANKCASE COVER OR SUMP

Position the engine so the crankshaft is horizontal before installing the crankcase cover or sump. Rotate the crankshaft so it will leave the number one cylinder intake valve at its maximum opening. Install appropriate gasket and slide cover or sump into place. **CAUTION:** Make sure governor gear teeth are in mesh. Use long, thin screwdriver to rotate governor gear if necessary.

GOVERNOR ADJUSTMENT

Loosen nut holding governor lever to governor shaft. Push governor lever counter-clockwise until throttle is wide open.

Hold governor lever in this position while rotating the governor shaft counter-clockwise as far as it will go. Tighten nut holding governor lever to governor shaft as shown in Fig. 11. Torque nut to 100 inch pounds.

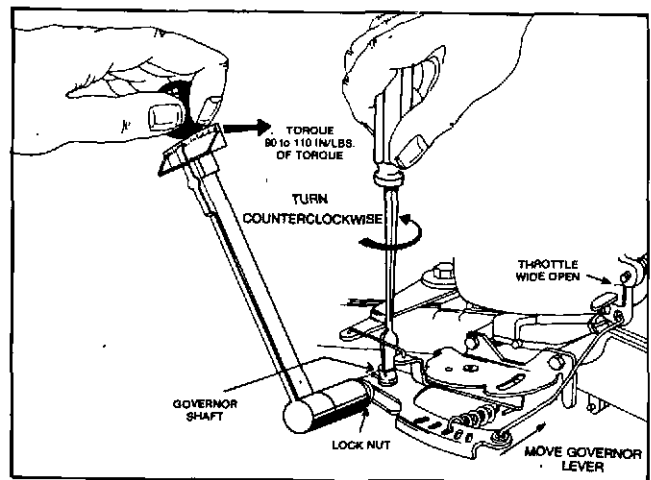

Fig. 11. Governor Adjustment

Section 6 COMPRESSION

COMPRESSION

Briggs & Stratton does not publish any compression pressures, as it is extremely difficult to obtain an accurate reading without special equipment.

It has been determined through testing, a simple and accurate indication of compression can be made as follows:

Check the compression by the use of a compression gauge. To do this, remove both spark plugs and insert a compression gauge in either number one or number two cylinder. Turn the engine over with the electric starter. There should be no more than a 25% pressure differential between each cylinder. A greater pressure differential indicates loss of compression.

Loss of compression will usually be the result of the following:

1. The cylinder head gasket blown or leaking.
2. Valves sticking or not seating properly.
3. Piston rings not sealing, which would also cause the engine to consume an excessive amount of oil.

Carbon deposits in the combustion chamber should be removed every 100 to 200 hours of use (more often when run at a steady load), or whenever the cylinder head is removed.

CYLINDER NUMBER LOCATION

To identify each cylinder location, a number is cast in the cylinder block. See Fig. 1.

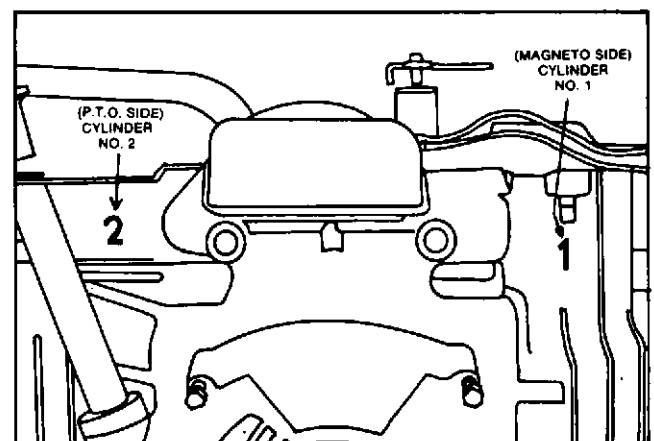

Fig. 1. Cylinder Number Location (P.T.O. Side of Engine)

REMOVE CYLINDER HEADS, SHIELDS & COVERS

The ducted engine has two cylinder air guides which must be removed before removing cylinder heads. See Fig. 2.

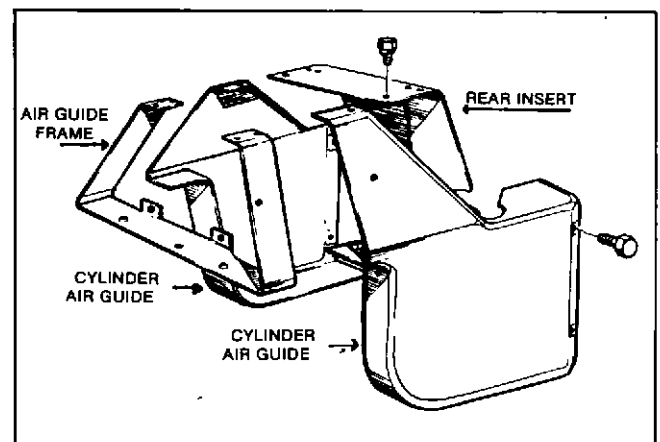

Fig. 2. Cylinder Ducting

COMPRESSION Cylinder Head

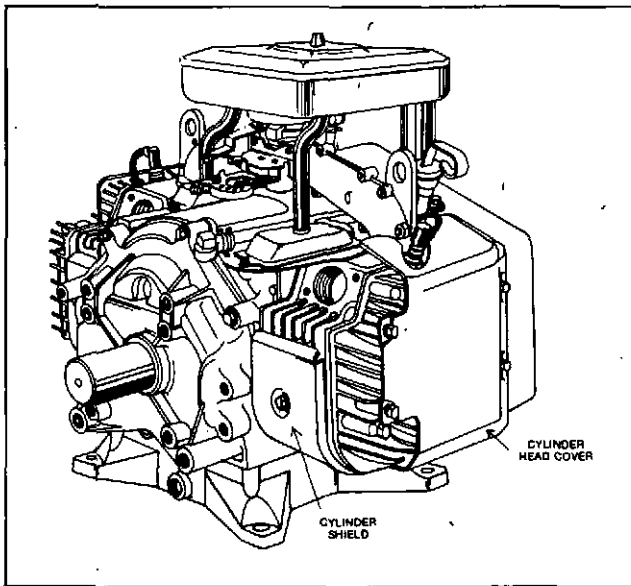

Fig. 3. Non-Ducted Engine

6

Always note the position of the different cylinder head bolts so that they may be properly reassembled. If a bolt is used in the wrong position, it may be too short and not engage enough threads. It may be too long and bottom on a fins, either breaking the fins, or leaving the cylinder head loose. Always use the long bolts around the exhaust valve area of the cylinder head. Fig. 4.

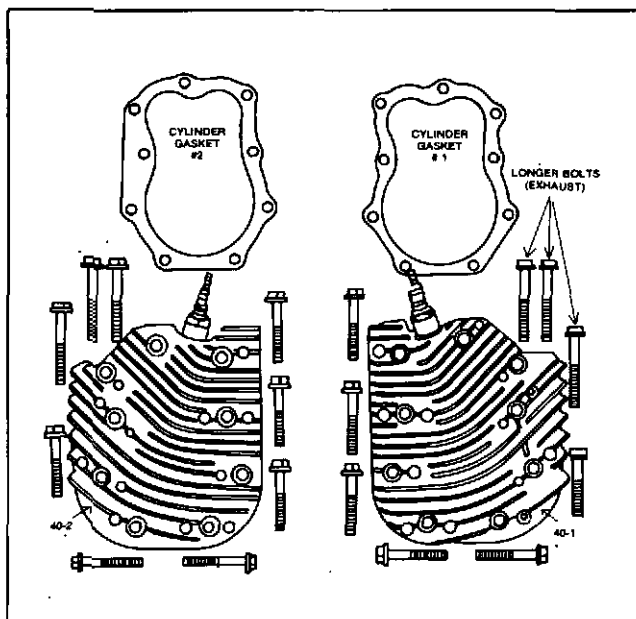

Fig. 4. Cylinder Head Bolt Location

CYLINDER HEAD TORQUE PROCEDURE

Assemble the cylinder head with the proper head gasket, and bolts in their proper order. If head gasket is defective replace with new gasket. Do not use a sealer of any kind on gasket. Tighten the screws down evenly by hand. Use a torque wrench and tighten head bolts in the sequence shown in Figure 5 to the specified torque, (160 inch pounds).

Do not torque one screw down completely before the others, as it may cause a warped cylinder head.

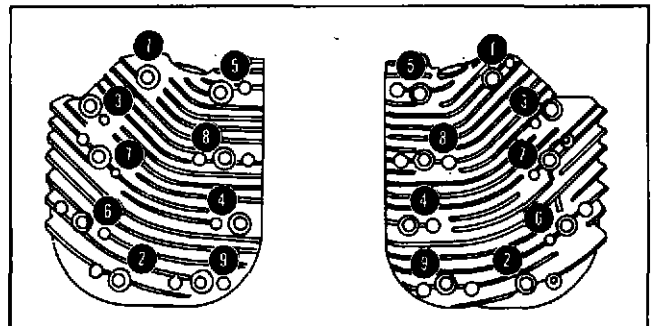

Fig. 5. Cylinder Head Torque Pattern

REMOVE VALVES

Figure 6 shows two methods used to retain the valve springs.

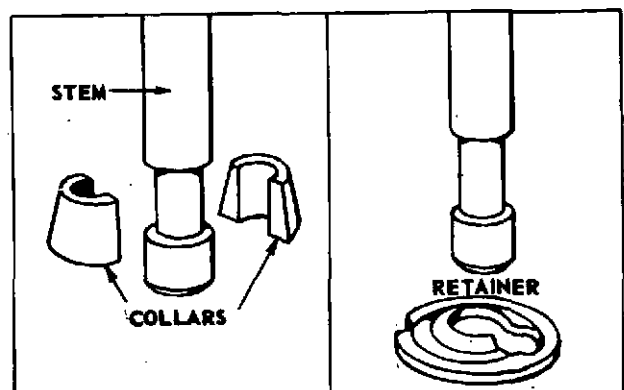

Illustration 1

Illustration 2

Fig. 6. Valve Spring Retainers

WHEN REMOVING VALVES, VALVE SPRINGS AND TAPPETS, MAKE SURE THAT THE PARTS ARE NOT INTERCHANGED.

To remove the exhaust valves, insert the compressor tool, slip the upper jaw between the spring and valve chamber, and the lower jaw below the retainer. Compress the spring. Remove the collars from the valve stem. Release the spring, and remove. Fig. 7.

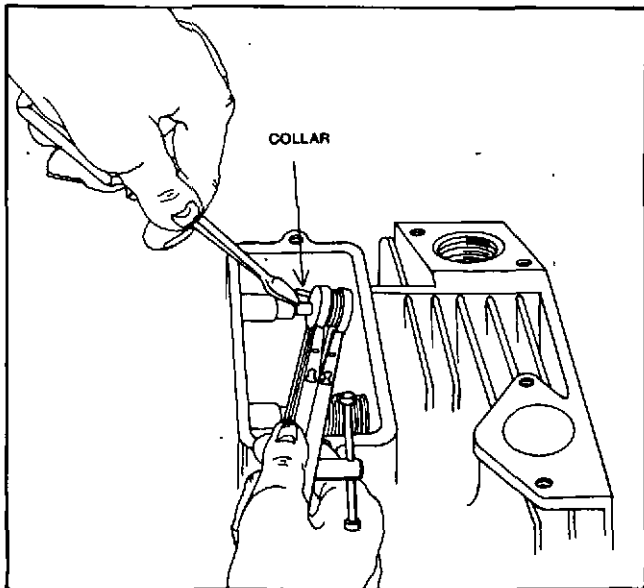

Fig. 7. Removing Retainers (Exhaust)

NOTE: The intake valves have a stem seal which is held in place by the valve spring. See Fig. 8.

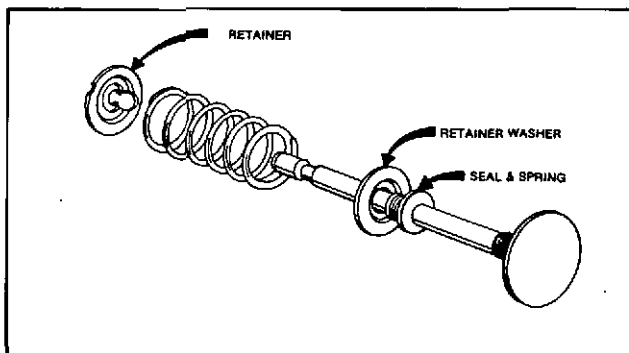

Fig. 8. Valve Stem Seal

To remove intake valves using retainers of the typed pictured in Figure 6, Illustration 2, slip the upper jaw of the 19063 compressor over the top of the valve chamber in the lower jaw between spring and retainer. Compress the spring and remove retainer. Fig. 9.

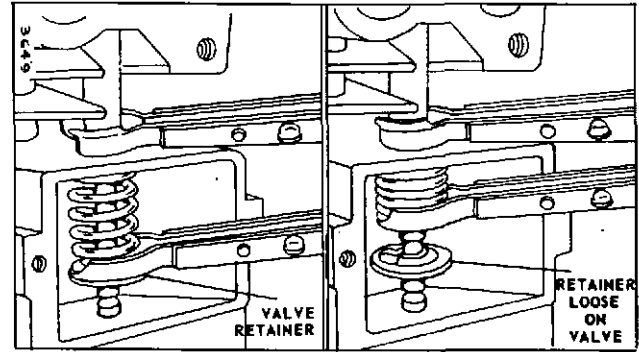

Fig. 9. Removing Retainer and Spring

Pull intake valve out slowly, being careful not to damage seal. **NOTE:** Add oil to stem when pulling the valve out, to avoid damaging the valve stem seal. Fig. 10. Remove all burrs from stem.

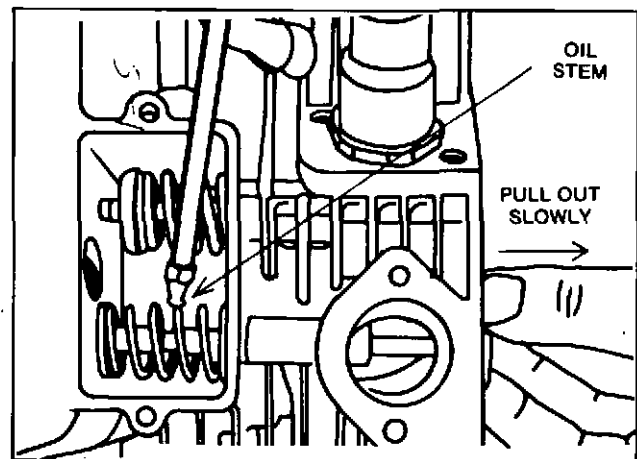

Fig. 10. Removing Intake Valve

REFACING VALVES AND SEATS

If valve face and seat are not sealing, lap or grind as necessary. Faces on valves and valve seats should be resurfaced with a valve grinder or cutter, only if necessary. The exhaust valve has an angle of 45° and the intake valve has a seat angle of 30°. Valve and seat should be lapped with a fine lapping compound. Use care to insure no lapping compound or cutter shavings are left in the cylinder valve ports. Valve seat width should be 3/64 to 1/16 of an inch. If the seat is wider, a narrowing stone or cutter should be used. If either seat or valve is badly burned, it should be replaced. Replace valve if margin is 1/64 or less after refacing. (See Figure 11.)

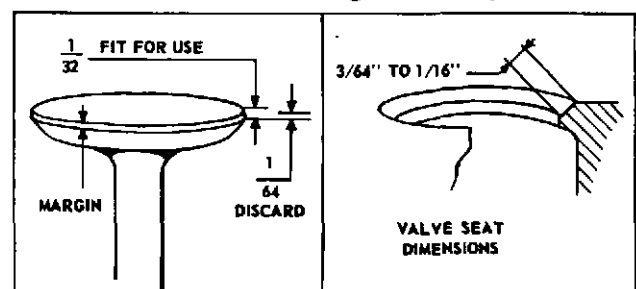

Fig. 11. Valve and Seat Dimensions

COMPRESSION Valves & Guides

To Check and Adjust Tappet Clearance

Insert the valves in their respective positions in the cylinder. Turn the crankshaft until exhaust valve is at its highest position. Then check clearance on the intake valve, with feeler gauge. See Table 1. Grind off the end of the valve stem if necessary, to obtain proper clearance. Then turn crankshaft until intake valve is at its highest position, and check exhaust valve clearance. NOTE: Check clearance cold.

**TABLE NO. 1
VALVE TAPPET CLEARANCE**

MODEL SERIES	INTAKE		EXHAUST	
	MIN.	MAX.	MIN.	MAX.
401400	.005	.007	.007	.009
401700				

NOTE: If clearance is measured without valve springs installed, add .002 to clearance shown.

6

INSTALL VALVES

Use heavier springs on the exhaust valves. Before installing valves, make sure that the valve guides and valve stem are free from abrasives or dirt. Apply a light film of oil to the valve stems before installing in the valve guides. See Fig. 13 for location of springs, retainers and seal.

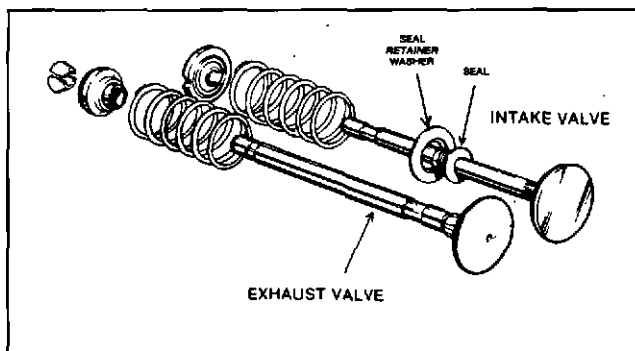

Fig. 13. Location of Valve Springs, Retainers and Seal Assembly

NOTE: A new stem seal should be installed if original is damaged.

INSTALLATION OF INTAKE VALVE AND STEM SEAL

Place the seal and valve seal retainer, (See Figure 13) in valve chamber. Insert intake valve stem through guide, (oil guide lightly), continue to push valve slowly, while inserting the end of the valve stem through the seal. Rotate the valve to prevent damaging seal. Figure 14.

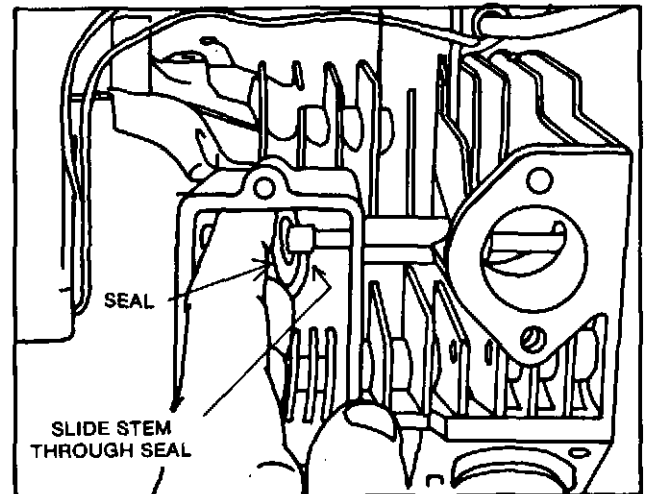

Fig. 14. Installing Valve Seal

Next, place the valve spring and retainer into the valve spring compressor 19063. Compress the spring until solid. The large diameter of the retainer should be away from the front of the valve chamber. Figure 15.

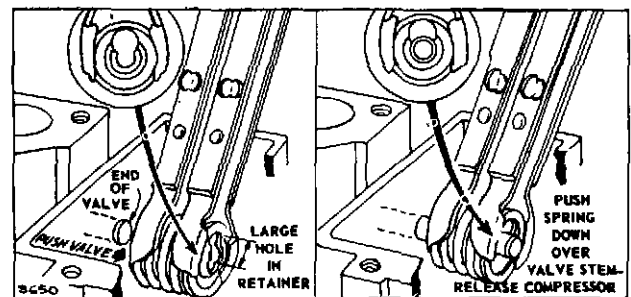

Fig. 15. Installing Valve Spring

Insert compressed spring and retainer into valve chamber. Open the spring compressor to approximately $\frac{3}{8}$ to $\frac{1}{2}$ inch. Push in the valve, and at the same time, press the seal and retainer further on to the valve stem. At this point, drop the valve stem through the larger area of the retainer slot and move the compressor to center the small area of the valve retainer slot on to the valve stem shoulder. Release the spring tension and remove the compressor.

INSTALLING EXHAUST VALVE AND RETAINER

Place valve spring and retainer in the valve spring compressor 19063. Compress the spring until it is solid. Insert the compressed spring and retainer into the valve chamber. Then, slide the valve into place, pushing the stem through the retainer. Hold the spring towards cylinder head and position the valve so its fully seated, insert the collars in the groove in the valve stem. Lower the spring until the retainer fits around the collars, release the valve spring compressor and pull out. **BE SURE THE COLLARS ARE IN PLACE.** Figure 16.

NOTE: Grease may be applied to stem and collars for ease in assembly.

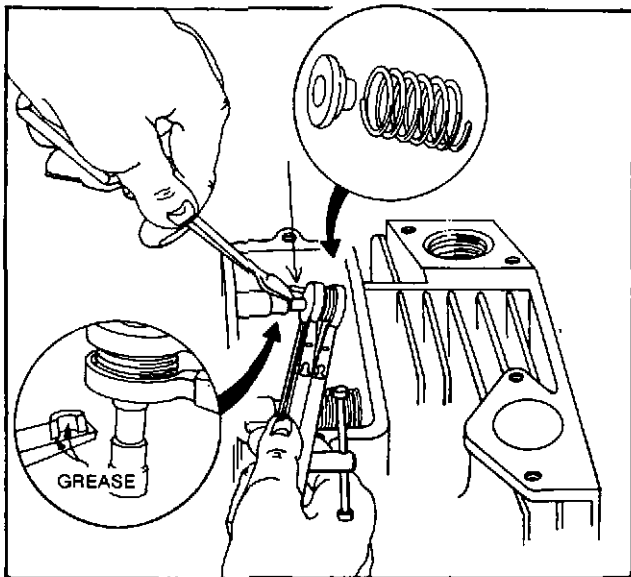

Fig. 16. Installing Exhaust Valve Retainers

Valve Guides

If the flat end of valve guide plug gauge 19151 can be inserted into the valve guide for a distance of $5/16''$, the guide is worn and should be rebushed in the following manner. Figure 17.

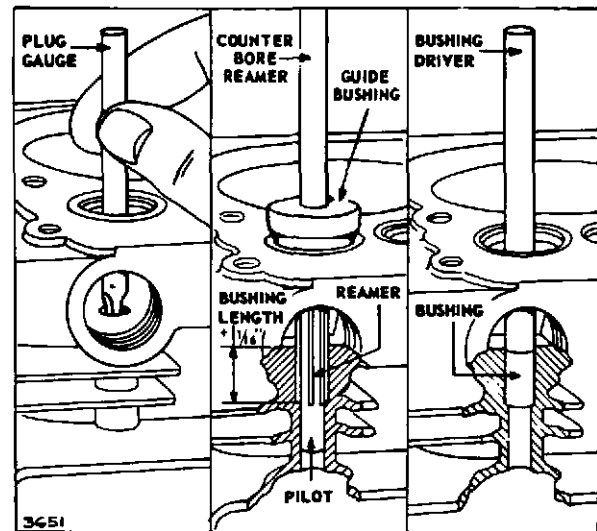

Fig. 17. Bushing Valve Guides

Use reamer 19183 and reamer guide bushing 19192 to ream out the worn guide. (Lubricate reamer with kerosene). Ream to only $1/16''$ deeper than valve guide bushing 230655. **DO NOT REAM THROUGH THE GUIDE.**

Press in valve guide bushing 230655 until top end of bushing is flush with top end of valve guide. Use a soft metal driver (brass, copper, etc.) so top end of bushing is not peened over.

The bushing 230655 is finish reamed to size at the factory, no further reaming is necessary, and a standard valve can be used.

CAUTION

Valve seating should be checked after bushing the guide, and corrected if necessary by refacing the seat.

COMPRESSION Valve Seat Inserts

To Remove Valve Seat Insert

Use valve seat puller #19138 as shown in Fig. 17, and select the proper puller nut. See Table 2. Be sure the puller body does not rest on the valve seat insert. Fig. 18. Turn the 5/16" bolt with a wrench until the insert is pulled out of the cylinder. Fig. 17.

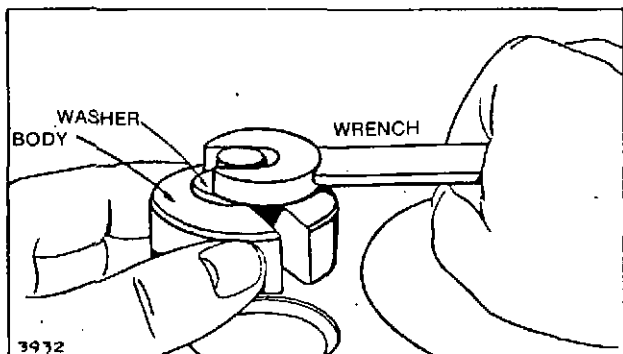

Fig. 17. Removing Valve Seat

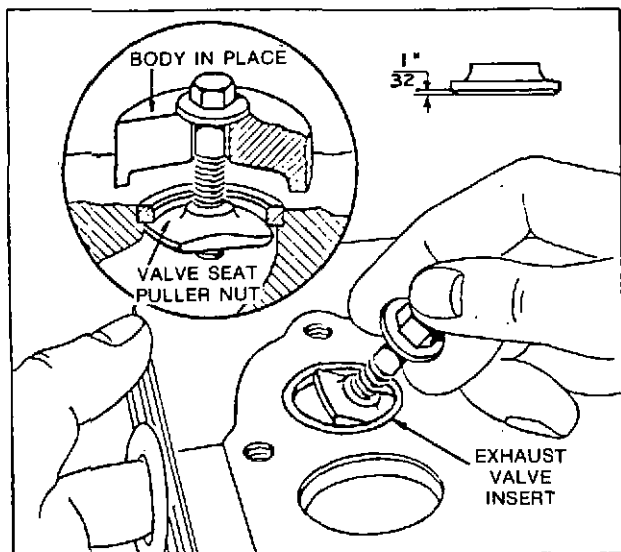

Fig. 18. Inserting Valve Seat Puller

NOTE: It may be necessary to grind the puller nut until the edge is 1/32" thick in order to get the puller nut under the valve seat insert. Fig. 18.

To Drive in New Valve Seat Insert

Select the proper valve seat insert and the correct pilot and driver according to Table 2 & 3. You will note that one side of the seat insert is chamfered at the outer edge. This side should go down into the cylinder.

Place the pilot into the valve guide, then drive the valve seat insert into place with the driver, as shown in Fig. 19. Use the old insert as a spacer between the driver and the new insert. Drive new insert until it bottoms. Top of insert will be slightly below cylinder head gasket surface. Then peen around the insert as shown in Fig. 20.

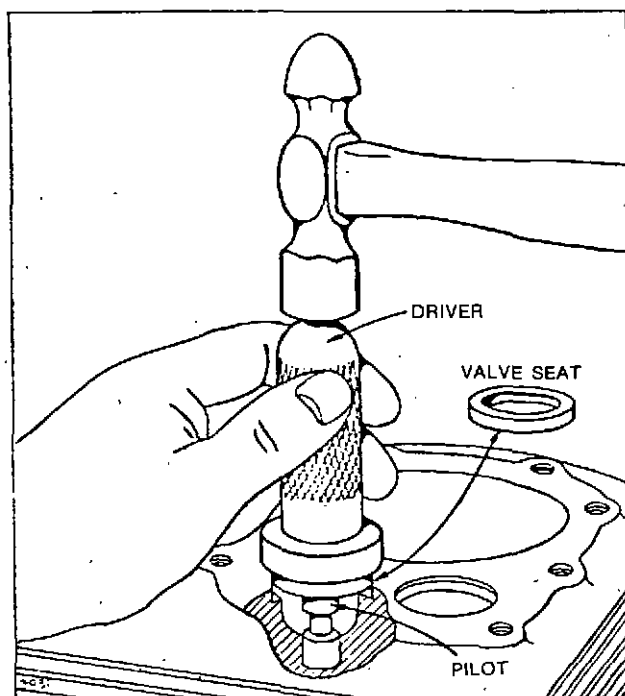

Fig. 19. Driving in Valve Seat

NOTE: A loose insert can be tightened. See Fig. 20.

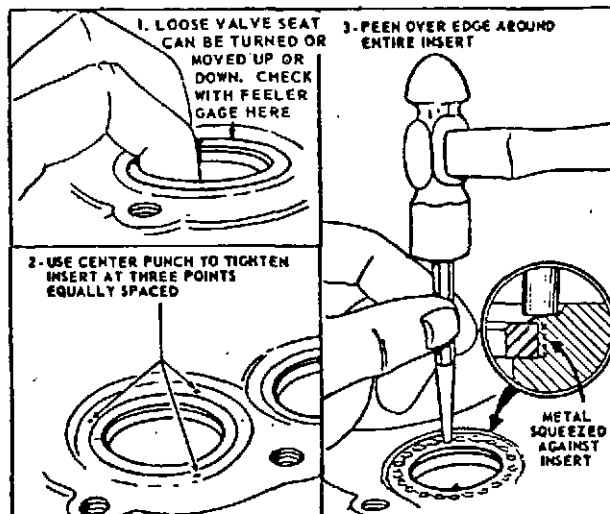

Fig. 20. Peening Valve Seat

NOTE: Replace cylinder if a .005 feeler gauge enters between valve seat and cylinder.

**COMPRESSION
Valve Seat Inserts**

**TABLE NO. 2
VALVE SEAT INSERTS**

BASIC MODEL SERIES	INTAKE STANDARD	EXHAUST STANDARD	EXHAUST STELLITE	INSERT # PULLER ASSEMBLY	PULLER NUT
401400, 401700	211661	211661	210940	19138	19141

**TABLE NO. 3
VALVE SEAT INSERT TOOLS**

BASIC MODEL SERIES	CUTTER & DRIVER PILOT	INSERT DRIVER
401400, 401700	19127	19136

Section 7

STARTERS & CHARGING SYSTEMS

GEAR DRIVE STARTERS 12 VOLT DC STARTER MOTOR USED ON MODEL SERIES 401400, 401700

This starter motor uses a gear type engagement method, similar to an automobile starter. When the starter motor is activated, the helix on the starter motor shaft drives a pinion gear into engagement with a ring gear attached to the engine flywheel, and cranks the engine. See Fig. 1 & 2 for location of starter motors.

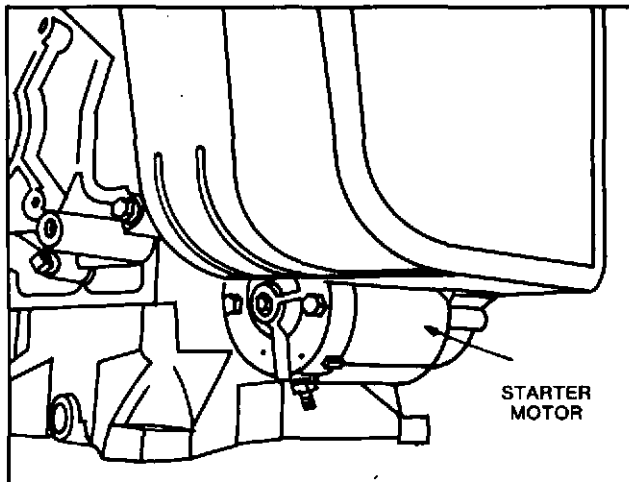

Fig. 1. Model Series 401400

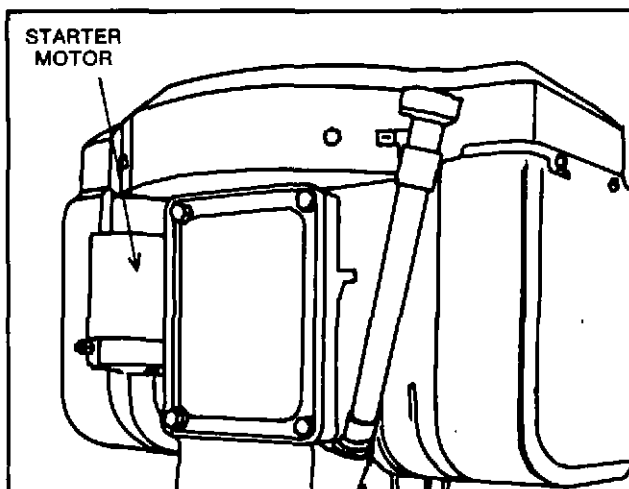

Fig. 2. Model Series 401700

CAUTION: DO NOT crank starter motor for more than one minute without cooling 15 minutes.

It is recommended a battery of 32 ampere hour capacity be used with 12 volt starter. The battery cable size should be #4 or #6.

REPLACING A RING GEAR

To replace a worn or damaged flywheel ring gear, proceed as follows.

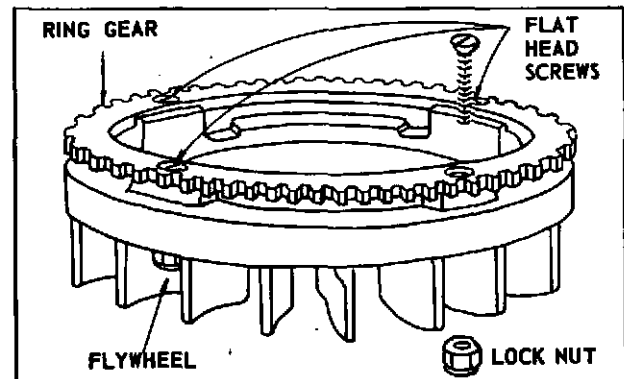

Fig. 3. Replacing Ring Gear

Mark the center of the rivets holding the ring gear to flywheel, with a center punch. Drill out the rivets using a 3/16" drill. Clean holes after drilling. Fig. 3. Heat flywheel to soften epoxy holding ring gear. Remove ring gear and clean epoxy from flywheel. Attach new gear to flywheel using four screws and lock nuts provided with gear.

NOTE: Epoxy is not required to hold replacement ring gear.

CHECKING STARTER MOTORS

If a starting problem is encountered, check the engine thoroughly to be sure it is not the cause of starting difficulty. It is a good practice to remove the spark plug and rotate the crankshaft by hand, to be sure it rotates freely. Any belt, clutch, or other parasitic load will affect cranking performance.

STARTERS

Gear Drive 12V

The following check list is given to aid you in diagnosing problems.

1. Cranks Engine Slowly—

- A. Battery discharged
- B. Faulty electrical connection
- C. Additional load affecting performance
- D. Dirty or worn starter motor commutator, bearing, etc.
- E. Worn brushes or weak brush spring
- F. SAE 30 engine oil below 40°

2. Engine Will Not Crank—

- A. Discharged or defective battery
- B. Faulty electrical connection
- C. Faulty starter motor switch (open circuit)
- D. Open circuit in starter motor
- E. Brushes sticking, etc.

3. Starter Motor Spins; But Does Not Crank Engine—

- A. Sticking pinion gear due to dirt
- B. Damaged pinion or ring gear
- C. Incorrect rotation due to reversed motor polarity - all motors rotate counterclockwise.

REMOVING STARTER

To remove the starter motor from the engine, first remove the blower housing and cover assembly from number two cylinder. Next loosen the two starter motor mounting bolts. Keep the outer bolt in position and remove the bolt behind the flywheel as shown in Fig. 5.

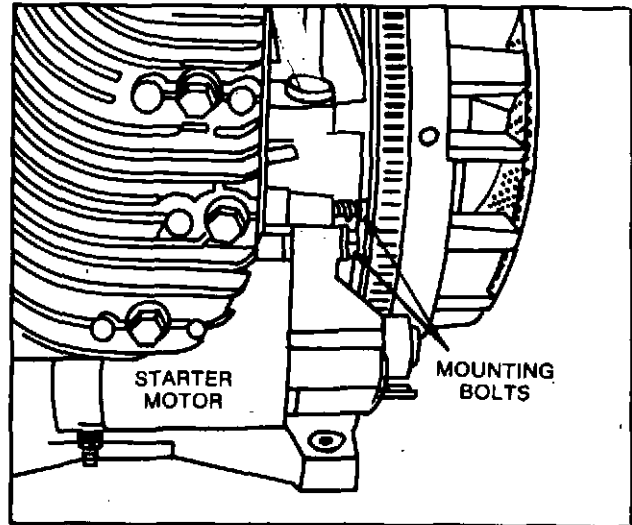

Fig. 5. Removing Starter Motor

The starter motor may now be removed for inspection or repair.

CHECKING STARTER MOTOR DRIVE

When the starter motor is activated, the pinion gear should rise, engaging the flywheel ring gear, and crank the engine. If the starter motor drive does not react properly, inspect the helix and pinion gear for freeness of operation. If any sticking occurs, this must be corrected. Proper operation of the starter is dependent on the pinion freely moving on the helix. See Fig. 4.

DISASSEMBLING STARTER MOTOR DRIVE

Clamp the starter drive cap, Fig. 6, in a vise, DO NOT CLAMP MOTOR SHELL IN VISE. Carefully, snap the plastic cap from the retainer using two screwdrivers, See Figure 6. If cap was damaged in the disassembly procedure, replace cap.

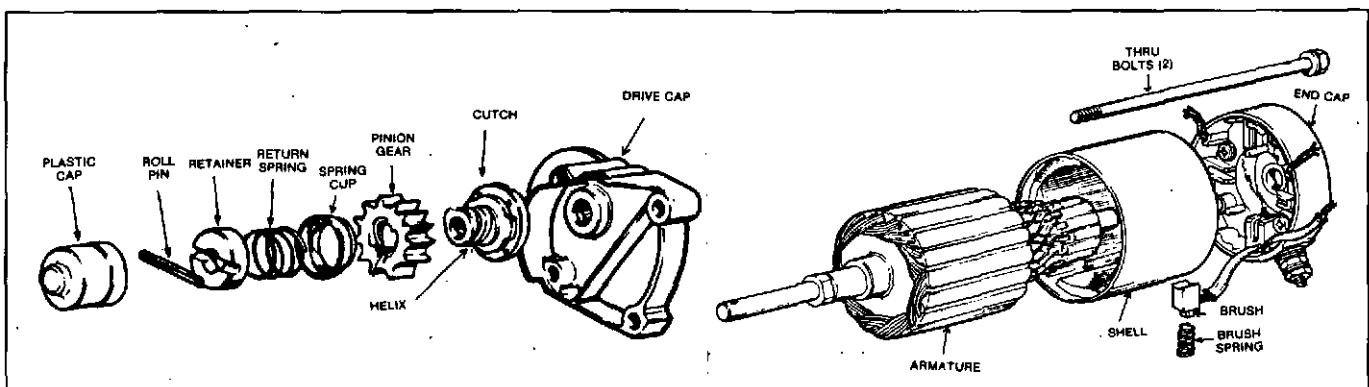

Fig. 4. 12 Volt Starter Motor Exploded View

STARTERS Gear Drive 12V

ASSEMBLING STARTER MOTOR DRIVE

Install the pinion gear with the beveled edge on the gear away from the starter. See Figure 8. After the clutch and gear have been assembled, install the cup, spring and retainer. Press or drive the roll pin through the slot on the retainer and the hole in the armature shaft. Make sure the split portion of the roll pin is positioned as shown in Figure 8, and also that the roll pin is centered within 1/32 of an inch.

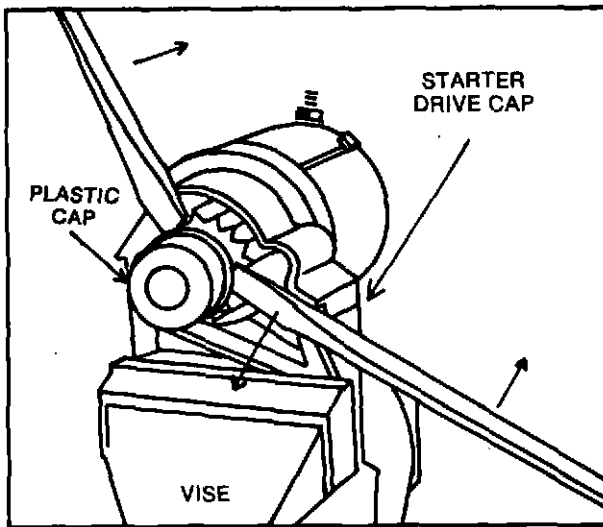

Fig. 6. Removing Plastic Cap

To remove the retainer, drive the roll pin out with a hammer, using a 1/8" diameter punch. Rest the retainer in a V-groove on a wooden block, see Figure 7.

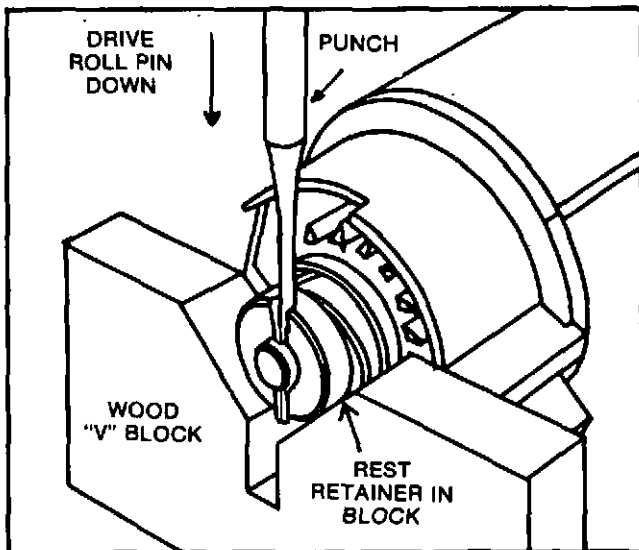

Fig. 7. Removing Roll Pin

The pinion gear should be inspected and replaced if it has damaged teeth. If the pinion gear has a tendency to stick or bind on the helix, replace the complete starter motor drive unit. **DO NOT LUBRICATE THE DRIVE ASSEMBLY.**

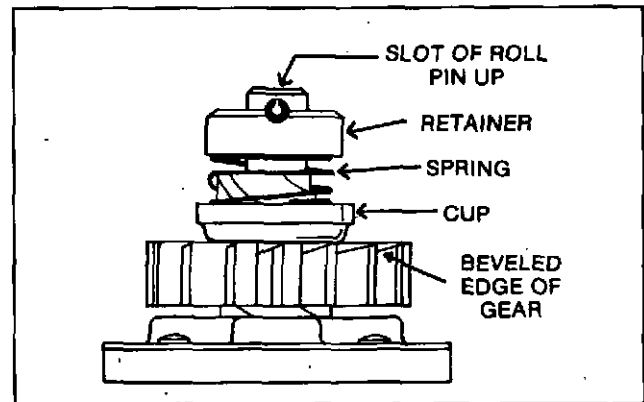

Fig. 8. Assembling Starter Motor Drive

To install plastic cap, use a socket approximately the same diameter as the plastic cap, for a driver as shown in Figure 9. Press cap in position, cap should lock in position when properly assembled.

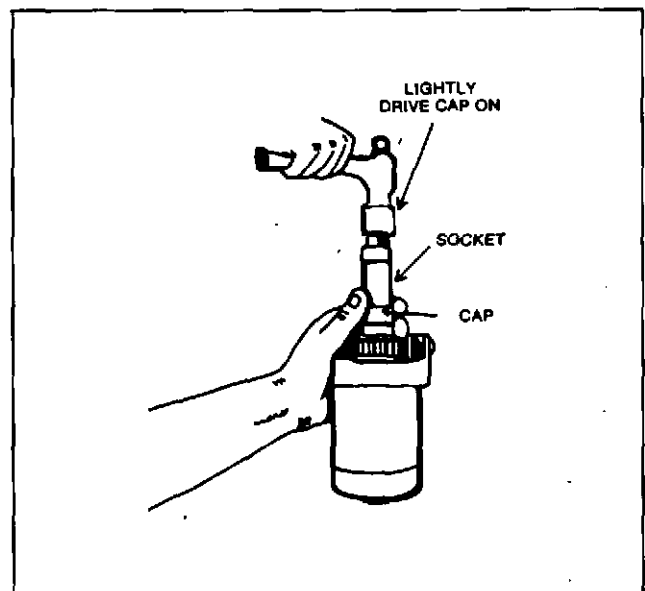

Fig. 9. Installing Plastic Cap

STARTERS

Gear Drive 12V

CHECKING STARTER MOTORS

A performance test of the 12 volt starter motor may be made in the following manner.

Equipment Needed —

1. A tachometer capable of reading 10,000 R.P.M.
2. A 12 volt battery ± 0.3 volts
3. An ammeter capable of reading 50 amperes

Connect the starter motor, battery and ammeter as shown on the accompanying illustration. See Fig. 10.

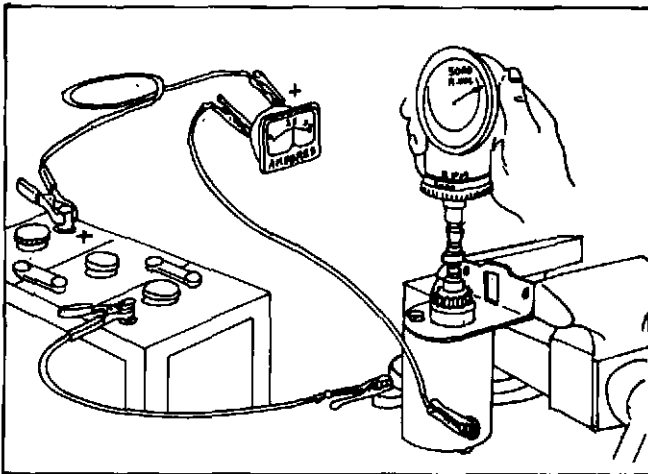

Fig. 10. Checking 12 Volt Starter Motor Performance

Insert the tachometer in the end of the starter motor and activate the starter motor. a starter motor in good condition will be within the following specifications.

- 1 Starter motor R.P.M. 6200 minimum.
2. Current draw (amperes) 16 maximum.
(Disregard surge current)

If the starter motor does not perform satisfactorily, the following should be checked, and corrected if necessary.

1. A binding or seizing condition in the starter motor bearings.
2. Starter motor brushes sticking in brush holders
3. A dirty or worn armature commutator or brushes.
4. A shorted, open, or grounded armature.

DISASSEMBLY OF STARTER MOTOR

To disassemble the starter motor, first follow the procedure to remove the starter motor drive. See Page 2. After the starter drive has been removed, disassemble the mounting bracket from the starter shell and end cap by removing the two thru bolts, See Figure 4.

Holding the armature shaft down, See Figure 11. slide the shell up and off the armature. NOTE: The armature should be in place in the end cap when doing this. Remove the armature from the end cap assembly. Proceed to make the visual inspection of the starter parts.

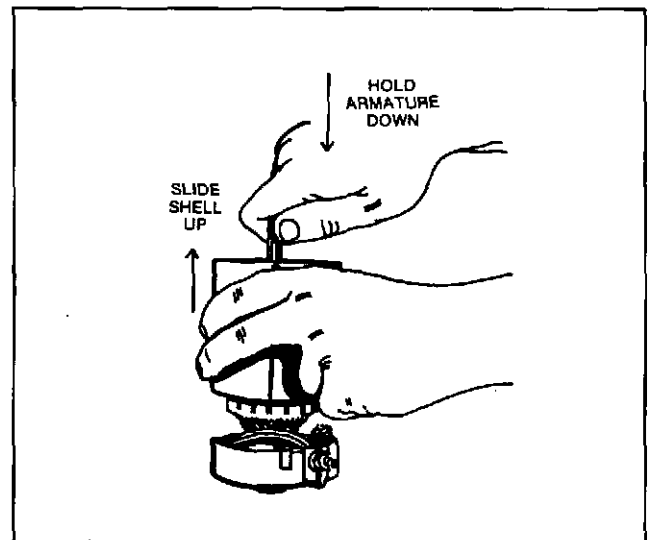

Fig. 11. Removing Motor Shell

CAUTION: Do not clamp the motor in a vise or strike the motor with a hammer. Motors include two powerful ceramic magnets which can be broken or cracked if the motor housing is deformed or dented.

Clean all dirt or corrosion accumulations from the armature, end cap, motor support, etc. The bearings, housing and armature should not be soaked in a cleaning solution. The armature commutator may be cleaned with a fine sand paper. Do not use emery cloth, as emery will embed in the commutator and cause rapid brush wear. If it is suspected that the armature is defective, a new armature should be tried in the motor. If proper testing equipment is available check the suspected armature to determine if it is

defective. The brushes should be checked for poor seating, weak brush springs, dirt, oil or corrosion. Brush spring pressure should measure from 17 to 25 ounces. Also check to be sure brushes are not sticking in their respective brush holders. See Fig. 13.

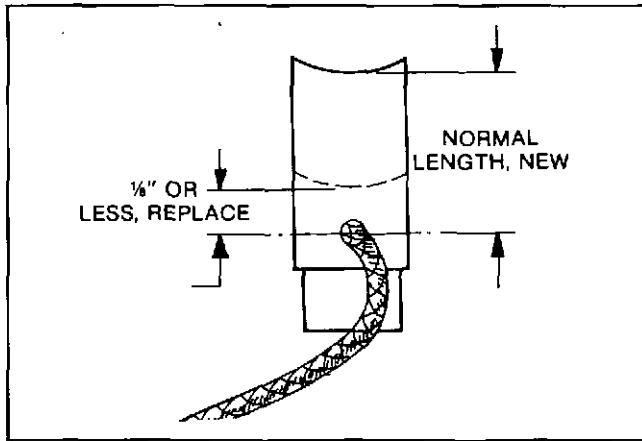

Fig. 12 Checking Brush Length

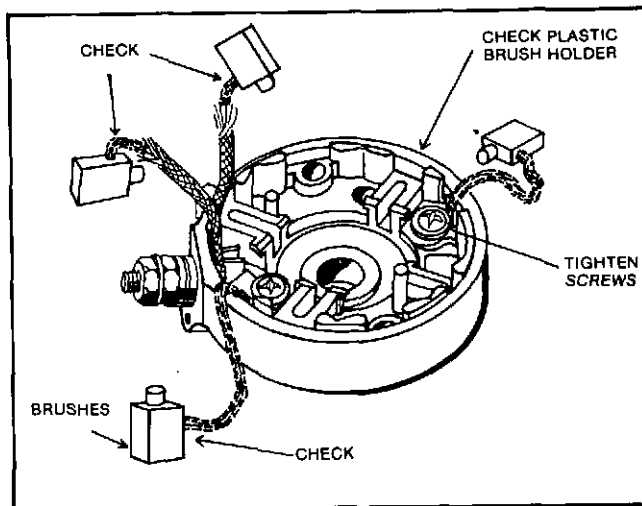

Fig. 13. End Cap Assembly

ASSEMBLY OF STARTER MOTOR

When all parts have been thoroughly inspected, lightly lubricate the end cap bearing with #20 oil, and reassemble in the following manner. Insert the brushes in their respective holders. NOTE: A tool such as shown in Figure 14 should be used to hold the brushes clear of the armature commutator when assembling. Install armature in the end cap, see Fig. 15.

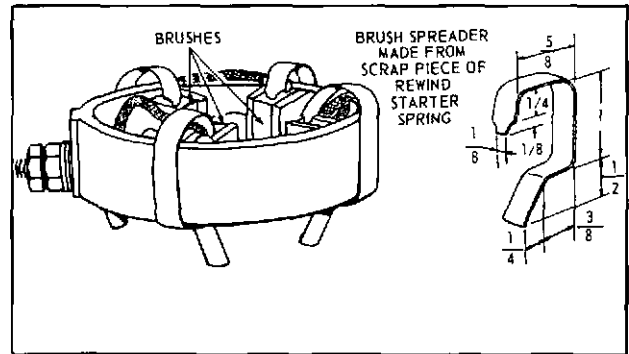

Fig. 14. Positioning Brushes

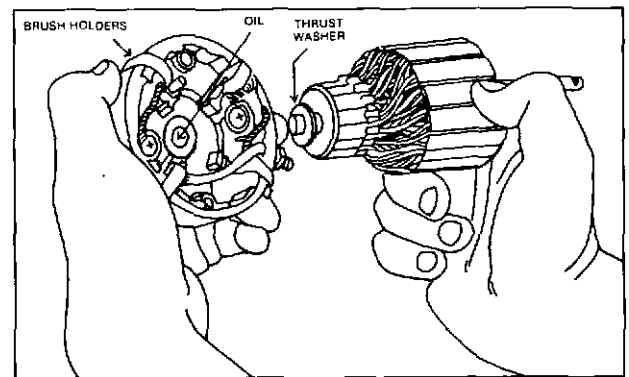

Fig. 15. Assembling Armature and End Cap

Carefully slide the motor shell over armature with notch toward end cap. Match the marks on end cap and shell Fig. 16. Slide the drive cap over the end of the armature and assemble thru bolts and lock-washer. Make sure the thru bolts are torqued to the 45-55 inch pound specification. Check the starter to make sure that the armature turns freely inside. Follow procedure for installation of the starter drive mechanism, given on Page 3.

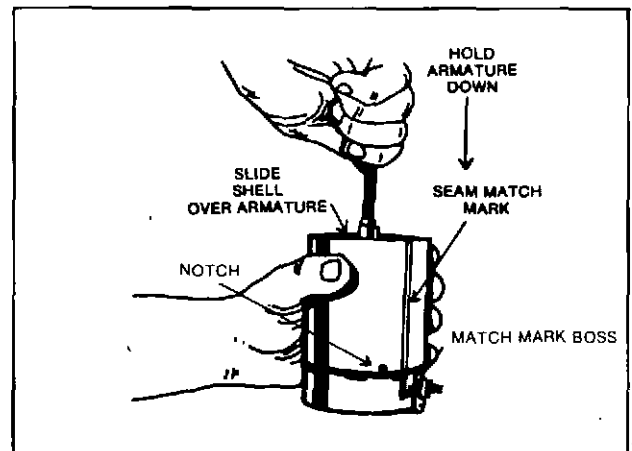

Fig. 16. Installing Shell

ALTERNATOR Test Equipment & Dual Circuit

EQUIPMENT REQUIRED TO TEST ALTERNATORS

1. Ammeter

Range 20-0-20; available from automotive parts supplier or use Briggs & Stratton No. 295158. Attach leads and alligator clips as shown in Figure 17. NOTE: Ammeter from multimeter may be used if 15 amp. range available.

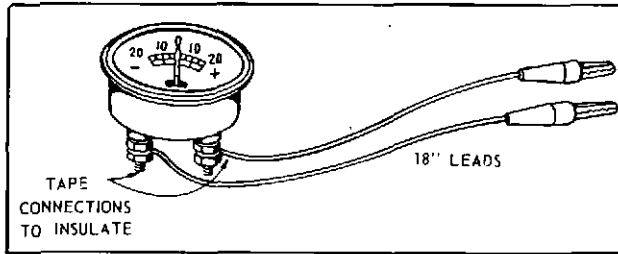

Figure 17

2. Test Lamp

12-volt bulb and bulb holder; available from automotive parts supplier, or use Briggs & Stratton No. 67245 bulb and No. 298586 bulb holder. Attach leads and alligator clips as shown in Figure 18.

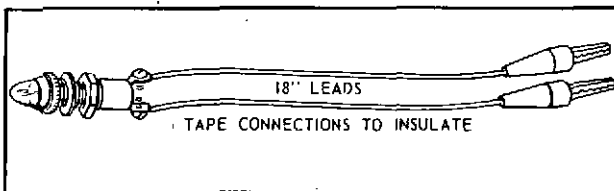

Figure 18

3. Load Lamp

G.E. No. 4001 sealed beam headlight or equivalent. Available from automotive parts supplier. Attach leads and clips as shown in Figure 19.

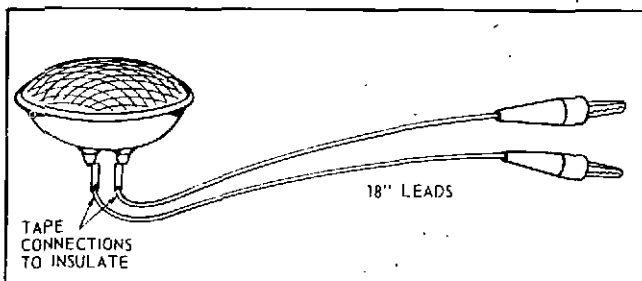

Figure 19

4. Multimeter

Eico Testor No. 540 or equivalent; available from radio or electronic parts supplier.

THE DUAL CIRCUIT ALTERNATOR

The Dual Circuit Alternator is actually two separate alternators. A single ring of magnets inside the flywheel supplies the magnetic field for both of them. One alternator uses a solid state rectifier and provides battery charging current. The other alternator feeds alternating current directly to the lights. Since the two are electrical-ly independent, use of the lights does not reduce the charge entering the battery.

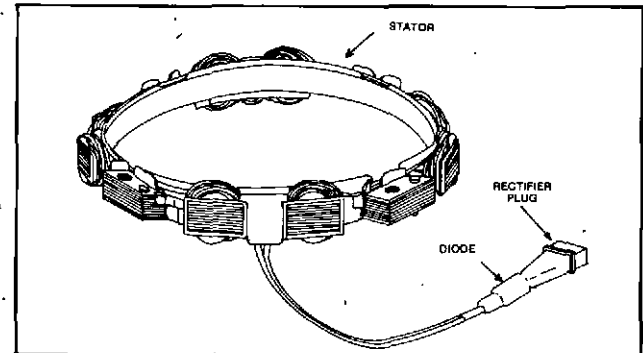

Figure 20. Alternator Assembly

The battery is not used for the lights, so lights are available even if the battery is disconnected or removed.

Current for the lights is available as long as the engine is running. The output depends upon engine speed. Twelve-volt lights with a total rating of 60 to 100 watts may be used. With lights rated at 70 watts, the voltage rises from 8V at 2400 RPM to 12V at 3600 RPM, so the brightness of the light changes with the engine speed. The 5 amp. lighting alternator uses less than .2 of a horsepower at full output.

The current from the battery charging alternator is unregulated and is rated at 3 amperes. The output rises from 2 amperes at 2400 RPM to 3 amperes at 3600 RPM, and uses less than .2 of a horsepower.

There is one external connection. The battery charging current connection is made through one terminal of a two connector plug. Current for lights is available at the second terminal of this plug. The plug is polarized to prevent improper connections. The return circuit for both alternators is through ground to the engine block.

ALTERNATOR Dual Circuit

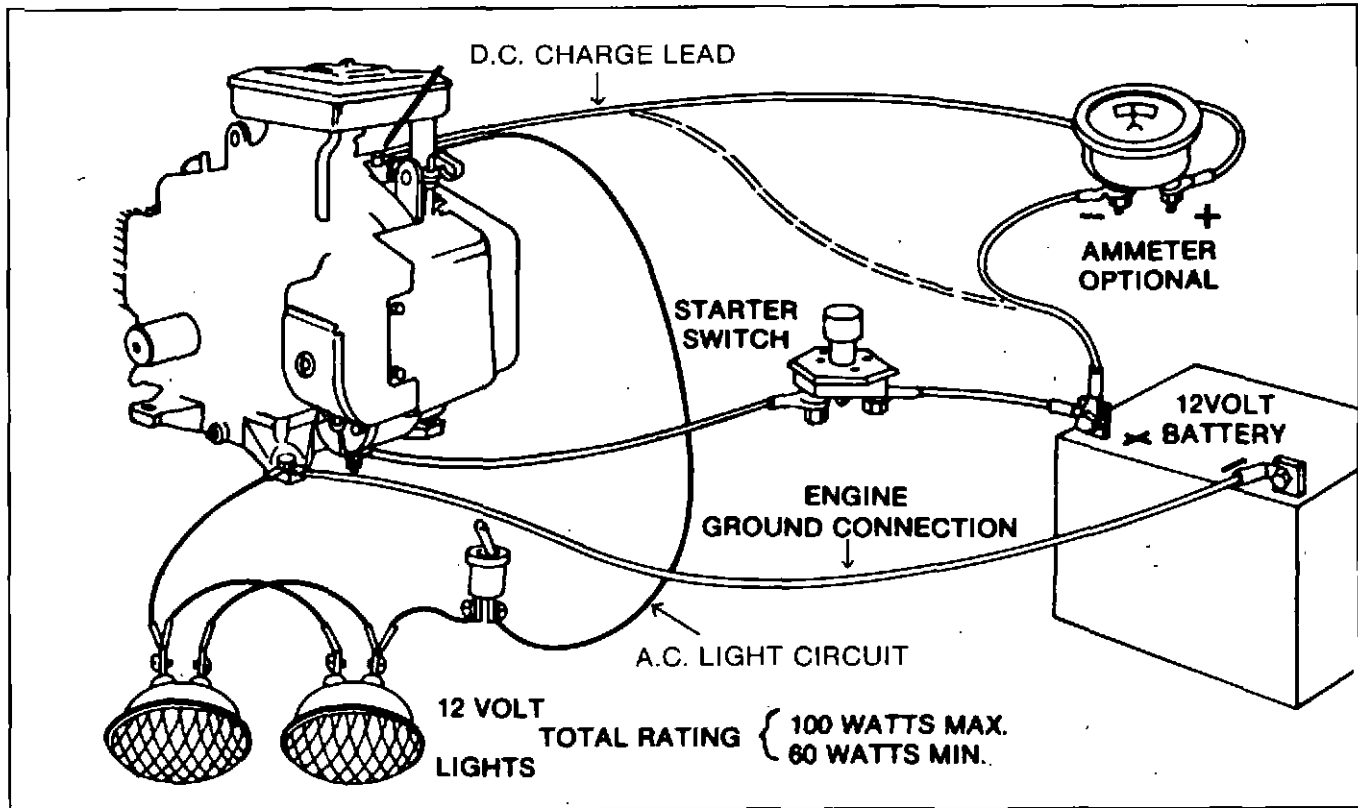

Fig. 21. Typical Wiring Installation

CHECKING DUAL CIRCUIT ALTERNATOR

Check if battery polarity is correct: Negative (-) side of battery should be grounded to engine or frame; positive (+) side of battery to alternator output lead. Figure 21.

WHEN CHECKING ALTERNATOR COMPONENTS, MAKE THE TESTS IN THE FOLLOWING SEQUENCE:

TESTING ALTERNATOR CHARGING OUTPUT

Install an ammeter in series with charging lead, as in Figure 22. Start engine. Ammeter should indicate output. The charge range is dependent upon the condition of the battery. If ammeter shows no charge, or shows a discharge, test stator and diode.

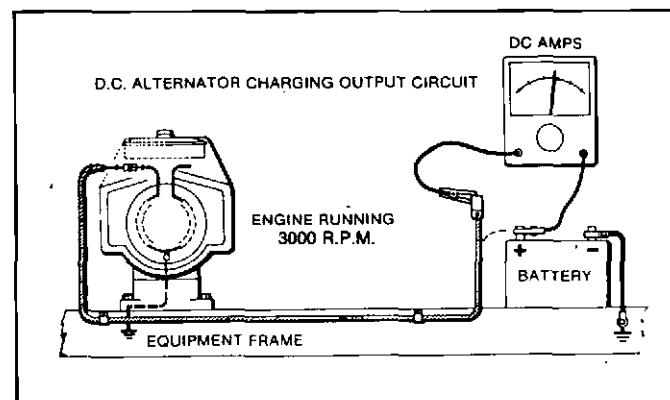

Figure 22. Testing Alternator Charging Output

TESTING FOR SHORT IN ALTERNATOR SYSTEM

Disconnect charging lead from battery, and connect charge lead test lamp in series between battery and charge lead. (Figure 23). DO NOT START ENGINE. Test lamp should not light. If it does light, stator charging lead is shorted or diode is defective. Disconnect charge lead connector at alternator. If test light does not go out, the lead from the cap to the battery is shorted. If light goes out, diode is defective. (See page 8 for testing diode.)

ALTERNATOR Dual Circuit

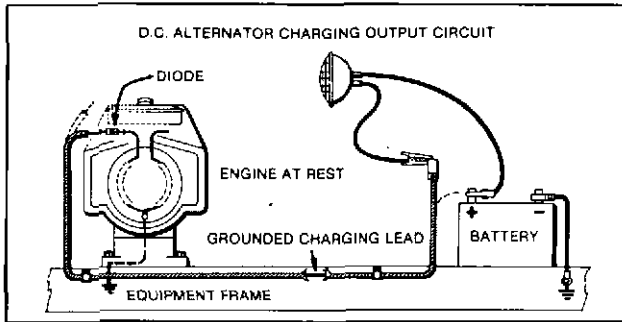

Fig. 23. Testing for Short in Stator, Diode or Charge Lead

TESTING DIODE

Disconnect charge lead plug from charge lead. Using multimeter set on resistance scale. Check diode by attaching one meter lead to red stator lead wire. (A needle may be used to pierce stator lead wire insulation). Touch the other multimeter lead to diode pin in plastic connector, then reverse meter leads. The meter should show continuity in one direction only. If meter shows a reading in both directions or does not show continuity in either direction, the diode is defective and must be replaced.

NOTE: Service replacement diodes are pre-assembled to a connector and a short lead wire for ease of installation.

TESTING STATOR CHARGING COILS

Remove blower housing, flywheel etc. and examine red lead wire for cuts, damaged insulation or obvious short on lead. If bare spots are found repair with electrical tape. If short cannot be repaired replace stator. Stator should also be checked for continuity as follows:

Use multimeter set on resistance scale. Touch one meter lead to stator laminations, touch the other meter lead to red stator charge lead wire. (Pierce red wire insulation with a needle to insure meter lead contact). Meter should show continuity.

Next remove screw which attaches stator ground wires to stator laminations. Be certain ground wire does not touch laminations and repeat previous test. Meter should not show continuity. If meter does not show continuity in first test or shows continuity during second test, stator is defective and must be replaced.

NOTE: Discoloration of stator coils does not mean stator is defective. A shorted diode will pass battery current thru stator coils to ground, which discolors coils due to heat. Replacing diode would normally restore alternator without replacing stator.

TESTING ALTERNATOR AC CIRCUIT (LIGHTING)

Connect load lamp to AC output plug and ground as shown in Figure 24. Load lamp should light to full brilliance at medium engine speed. If lamp does not light, or is very dim at medium speeds, remove blower housing and flywheel. Disconnect the ground terminal end of AC coil, which is attached to the stator laminations with a screw.

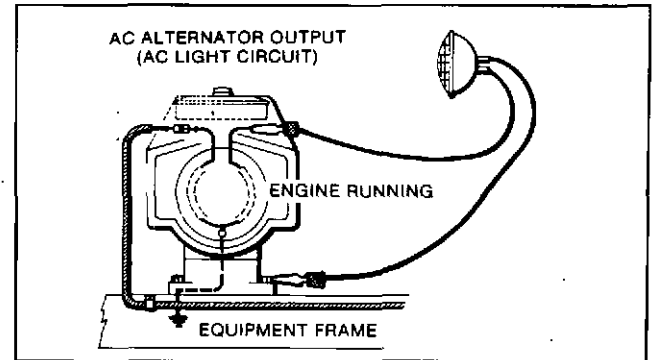

Fig. 24. Testing A.C. Lights Circuit Output

With multimeter, check continuity between ground lead of AC coil and AC output connector as shown in Figure 25. Meter should show continuity.

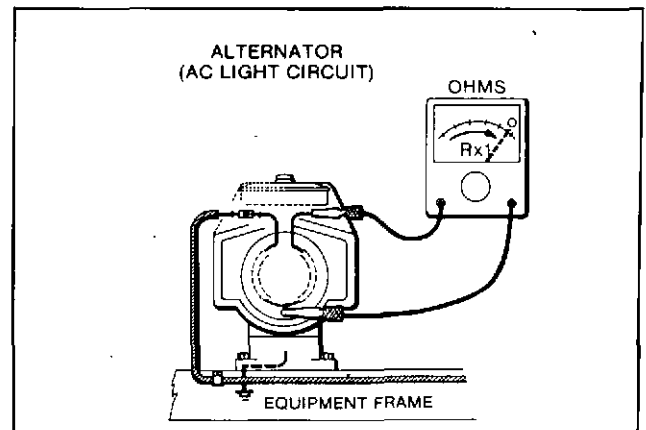

Fig. 25. Testing A.C. Circuit for Continuity

Next, be sure ground lead terminal is not touching a grounded surface, and check continuity from terminal to ground.

Meter should not show continuity. If meter indicates continuity, coils are grounded and defective. Examine black lead to be sure the insulation is not worn or cut. Repair with tape and shellac if a bad spot is found. If ground still exists, or if AC coils do not show continuity, stator must be replaced.

THE TRI-CIRCUIT ALTERNATOR

The Tri-Circuit alternator consists of a single ring of magnets inside the flywheel, which supplies the magnetic field for a stator having one output lead which produces A.C. voltage. The output lead connects to a charge lead that contains one diode which rectifies minus -12 volts D.C. (5 amps. at 3600 R.P.M.) for lights. This same charge lead contains a second diode that rectifies plus +12 volts D.C. (5 amps. at 3600 R.P.M.) for battery charging and external loads. See Fig. 26.

If an accessory such as an electric clutch is used on the equipment, 3.5 amps powers the clutch, and up to 1.5 amps charges the battery, thus not over-charging the battery. A two-pole clutch switch is used on the vehicle when an electric clutch is an accessory. When the clutch is switched on, one circuit is used to engage the clutch, and the other circuit bypasses the resistor, thus allowing full alternator output to be applied to the battery and clutch, (See Figure 26)

If the clutch is not engaged a resistor is placed in series with the alternator charge lead, thereby limiting the charge current to about 3 amps. See Fig. 26. The resistor (20 watts), becomes hot and must be mounted somewhere on the vehicle by the manufacturer.

The battery is not used for the lights, so lights are available even if the battery is disconnected or removed.

Current for the lights is available as long as the engine is running. 12V lights with a total rating of 60 to 100 watts may be used. With lights rated at 70 watts, the voltage rises from 8V at 2400 RPM to 12V at 3600 RPM, so the brightness of the light changes with the engine speed. The 5 amp. lighting alternator uses less than .2 of a horsepower at full output.

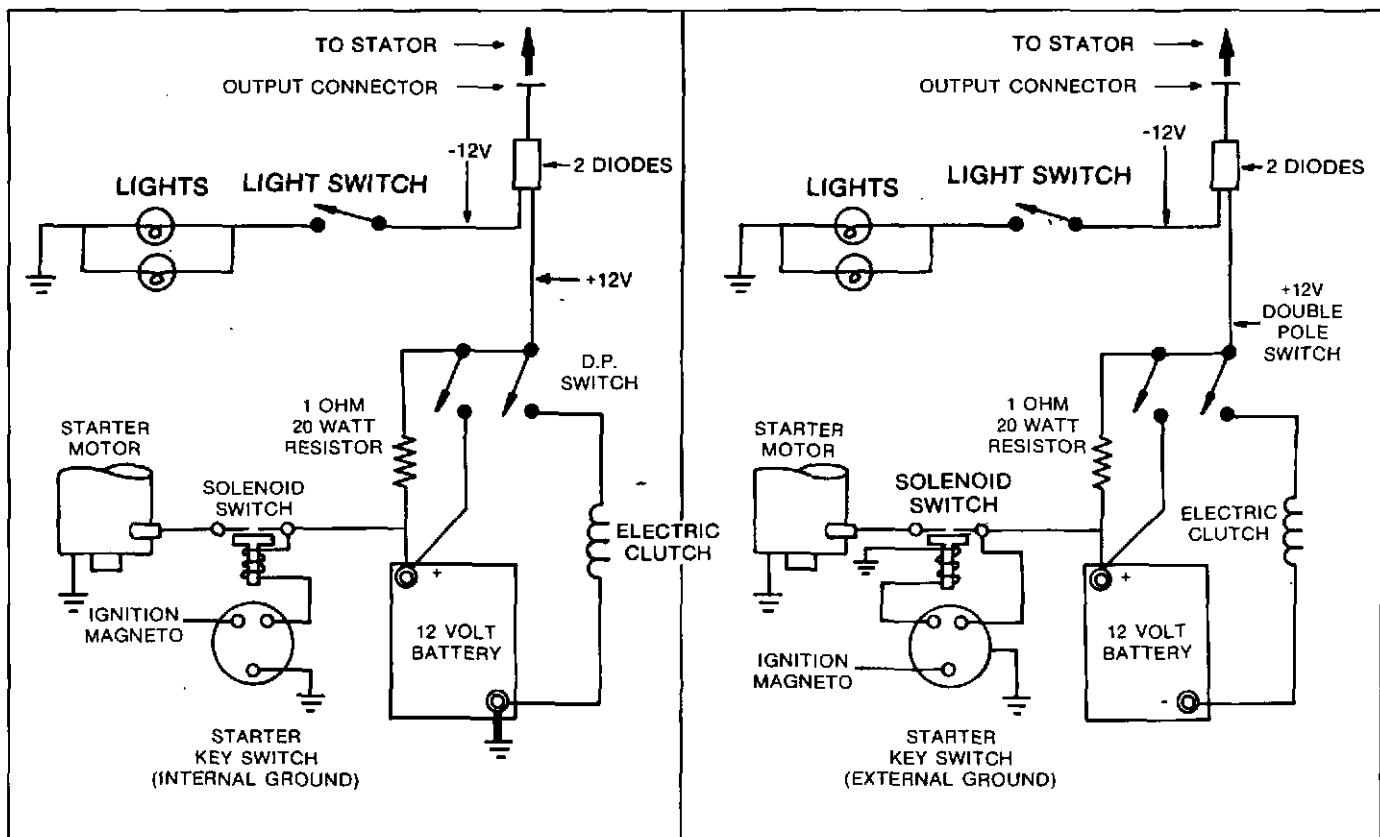

Fig. 26. Typical Tri-Circuit Alternator Wiring Diagrams

ALTERNATOR Tri-Circuit

TESTING ALTERNATOR STATOR OUTPUT

Connect load lamp to AC output plug and ground as shown in Figure 27. Load lamp should light to full brilliance at medium engine speed. If lamp does not light, or is very dim at medium speeds, remove blower housing and flywheel. Disconnect the ground terminal end of AC coil, which is attached to the stator laminations with screw.

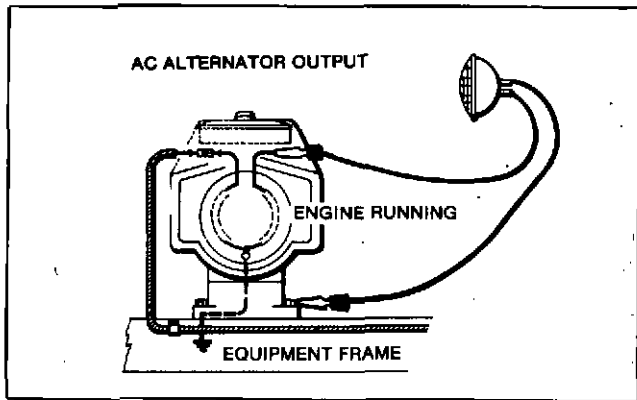

Fig. 27. Testing Stator Output

With multimeter, check continuity between ground lead of AC coil and AC output connector shown in Figure 26 & 28. Meter should show continuity.

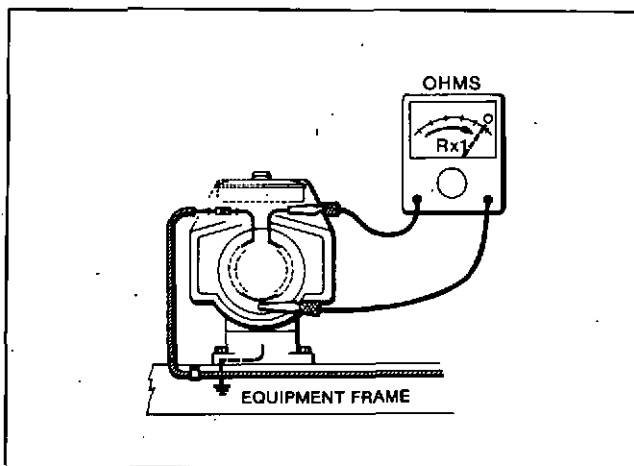

Fig. 28. Testing Stator Winding for Continuity

Next, be sure ground lead terminal is not touching a grounded surface, and check continuity from terminal to ground.

Meter should not show continuity. If meter indicates continuity, coils are grounded and defective. Examine black lead to be sure the insulation is not worn or cut. Repair with tape and shellac if a bad spot is found. If ground still exists, or if AC coils do not show continuity, stator must be replaced.

CHECKING DIODES

Disconnect charge lead from stator output lead. Using a multimeter set on resistance scale, check diodes by attaching one meter lead to connector pin. Touch the other meter lead to the white wire (Light Circuit diode), then reverse meter leads. Meter should show continuity in one direction only. Repeat this procedure for the red wire (battery charging diode). Meter should show continuity in one direction only. If meter shows continuity in both directions or does not show continuity in either direction the charge lead must be replaced. See Fig. 29.

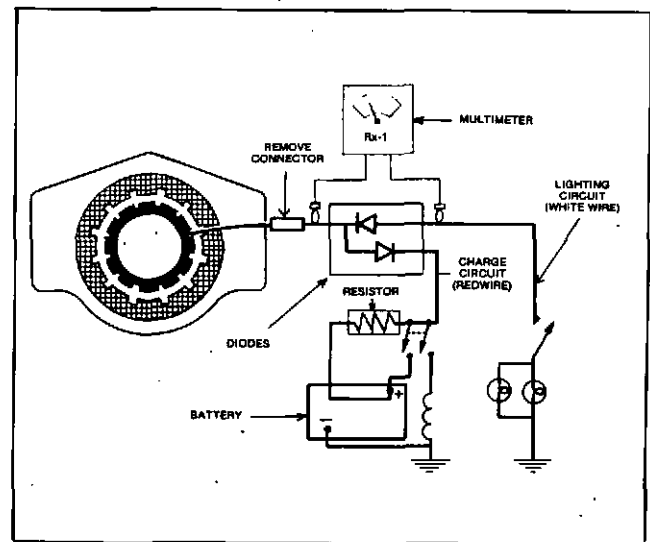

Fig. 29. Testing Diodes

The resistor that reduces battery charging current should also be checked when testing alternator. See Fig. 30. An acceptable resistor should have approximately one ohm resistance. Also check to be certain the double pole double throw switch is operating properly. See Fig. 26. for wiring diagrams.

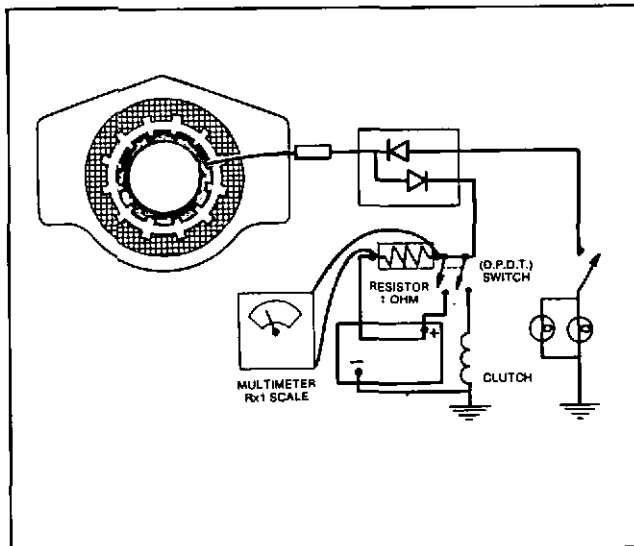

Fig. 30. Checking Resistor

Section 8 LUBRICATION

LUBRICATION

Oil has four purposes. It cools, cleans, seals and lubricates. Briggs & Stratton twin cylinder engines are lubricated with a gear-driven oil slinger on vertical crankshaft models or a connecting rod dipper on horizontal crankshaft models.

The crankcase capacity of the twin cylinder engine is 3.5 pints. (1.65 liters). **CAUTION: DO NOT OVERFILL. CHECK OIL LEVEL REGULARLY. BE SURE OIL LEVEL IS MAINTAINED. CHANGE OIL AFTER FIRST 5 HOURS OF OPERATION.** Thereafter, change oil every 25 hours of operation. Remove oil drain plug and drain oil while engine is warm. Replace drain plug. Remove dipstick and refill with new oil of proper grade. See Figure 1 and 2 for location of drain plugs, for horizontal and vertical engines.

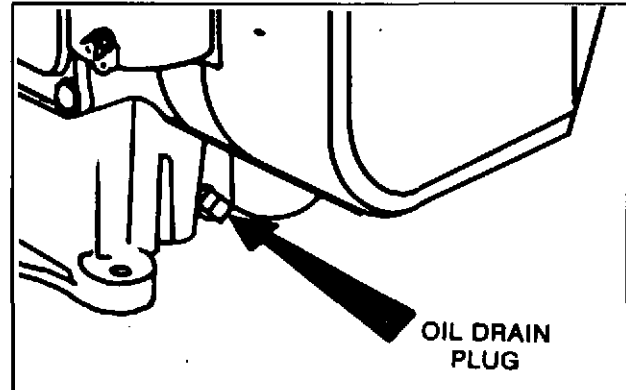

Fig. 2. Vertical Crankshaft Engine

Oil Recommendations

Any high quality detergent oil having a classification which includes "MS", "SC", "SD" or "SE" can be used in Briggs & Stratton engines. Detergent oils keep the engine cleaner and retard the formation of gum and varnish deposits.

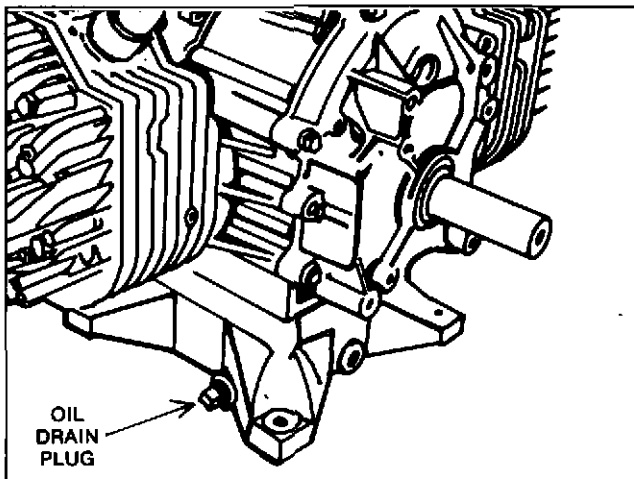
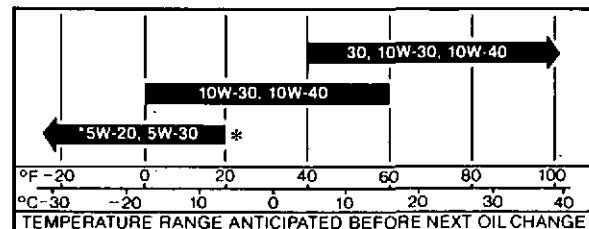

Fig. 1. Horizontal Crankshaft Engine

RECOMMENDED SAE VISCOSITY GRADES



*If not available, a synthetic oil may be used having — 5W-20, 5W-30 or 5W-40 viscosity.

The oil recommendations are the result of extensive testing. No special additives should be used.

LUBRICATION

Breathers

EXTENDED OIL FILL and DIPSTICKS

Model Series 401400

The horizontal crankshaft engine uses a steel oil fill tube and "snap in" dipstick. The bottom of the tube is pressed into a rubber grommet. To secure the filler tube, a bracket is attached to the blower housing. Fig. 3.

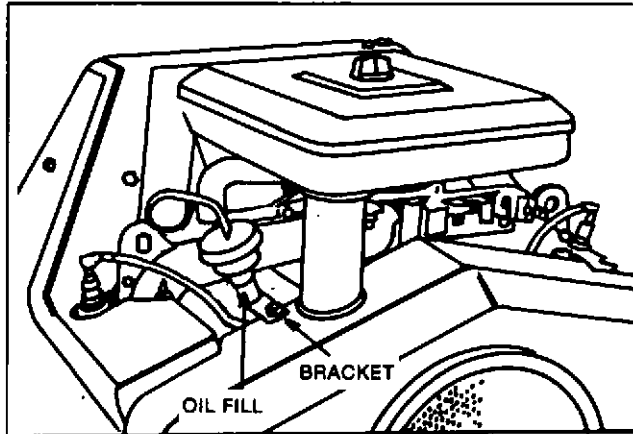

Fig. 3. Horizontal Crankshaft

Model Series 401700

The vertical crankshaft engine uses a plastic screw cap, dipstick and tube assembly. When installing the extended oil fill and dipstick assembly, the tube must be installed so the "O" ring seal is firmly compressed. To do so, push the tube down toward the sump, then tighten blower housing screw, which is used to secure the tube and bracket. See Fig. 4.

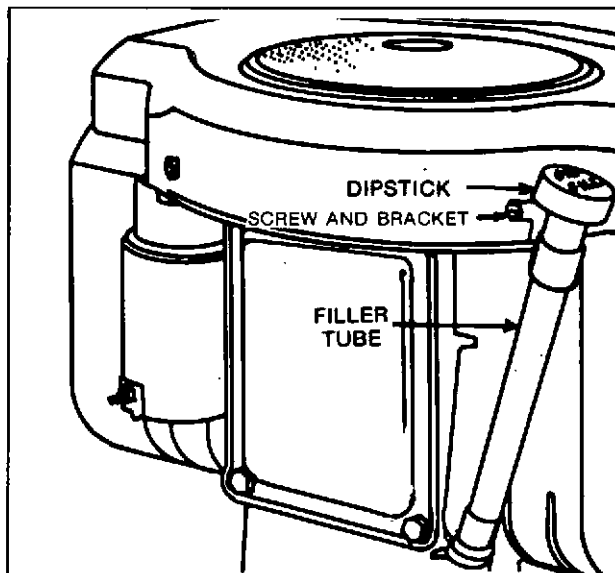

Fig. 4. Vertical Crankshaft

A LEAK AT THE SEAL BETWEEN THE TUBE AND SUMP, OR AT THE SEAL AT THE UPPER END OF THE DIPSTICK CAN RESULT IN A LOSS OF CRANKCASE VACUUM, AND A DISCHARGE OF SMOKE THROUGH THE MUFFLER.

Caution owners not to overfill the sump or crankcase with oil when using the extended filler dipstick. The dipstick is marked "DO NOT OVERFILL". Excessive oil will cause a smoking condition, as the engine attempts to discharge the surplus oil, and may cause the engine to overheat.

BREATHERS

It is the breather's function to maintain a vacuum in the crankcase. The breather has a fiber disc valve, which limits the direction of air flow caused by the piston moving back and forth. Air can flow out of the crankcase, but the one way valve blocks the return flow, thus maintaining a vacuum in the crankcase.

A partial vacuum must be maintained in the crankcase to prevent oil from being forced out of engine, at the piston rings, oil seals, breaker plunger and gaskets.

CHECKING BREATHERS

To remove the breather assemblies first remove the carburetor air cleaner and intake manifold assembly. Follow the procedure given in carburetion, section 3, page 2 and 3. Remove the dipstick tube before removing air guide, See Fig. 5 and Fig. 6. The breathers may now be removed.

NOTE: Two breathers are used on some models.

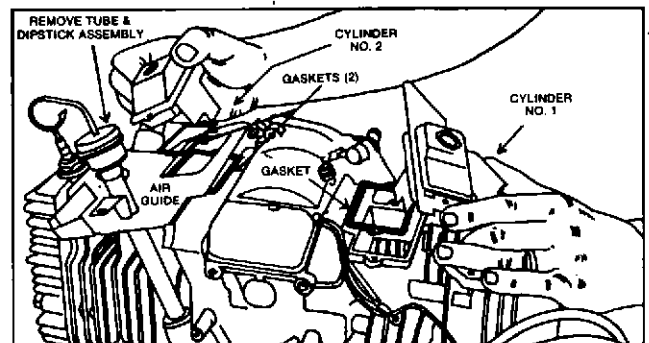

Fig. 5. Model Series 401400

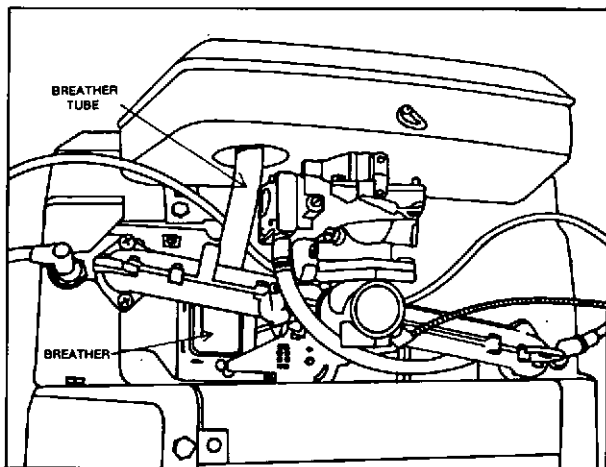

Fig. 6. Model Series 401700

Checking Breathers

If the fiber disc valve is stuck or binding, the breather cannot function properly and must be replaced. A .045" wire gauge should not enter the space between the fiber disc valve and body. (A sparkplug wire gauge may be used.) Check as shown in Fig. 7 NOTE: The fiber disc valve is held in place by an internal bracket which will be distorted if pressure is applied to the fiber disc valve. Therefore, do not apply force when checking with wire gauge.

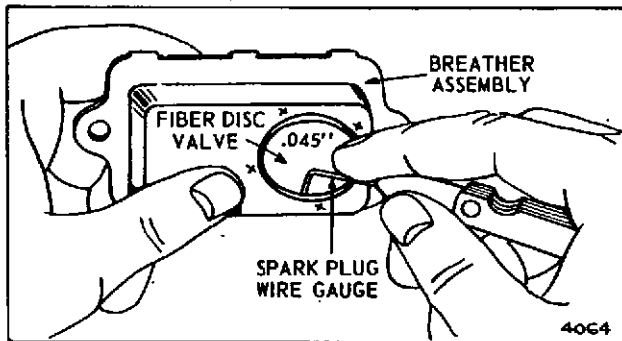

Fig. 7. Checking Breathers

If breather is removed for inspection, or valve repair, a new gasket should be used when replacing breather. Tighten screws securely to prevent oil leakage.

Breathers are vented through the air cleaner, to prevent dirt from entering the crankcase. Check to be sure venting elbows or tubes are not damaged and seal properly.

INSTALLING BREATHERS

When installing breathers, make sure the breather gaskets are located properly. See Figure 8 for location of the notches on the gasket. Also route the spark plug cables & primary and ground wire through the recess in the air guide. See Figure 9.

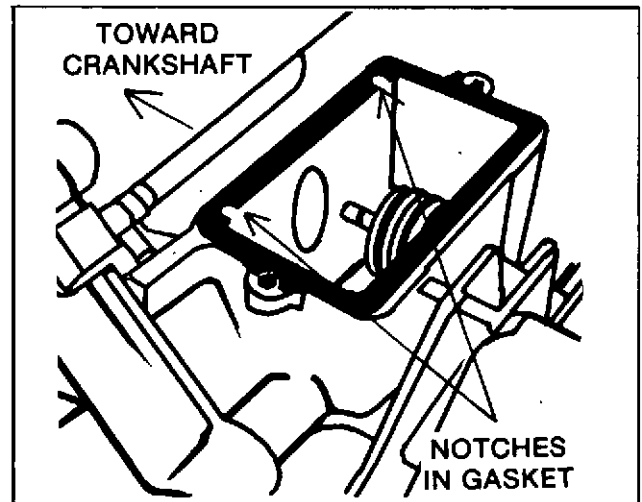

Fig. 8. Gasket Location

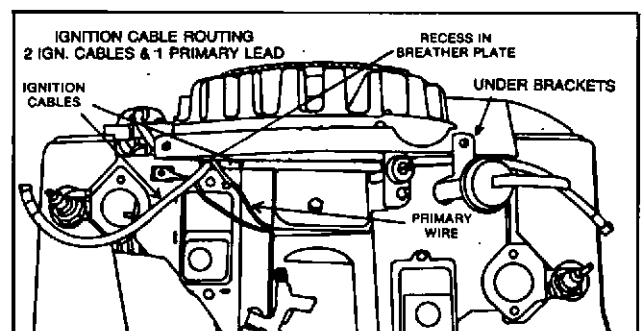

Fig. 9. Routing of Ignition Wires

To install number two cylinder breather, place a gasket between the valve chamber and air guide. A second gasket is placed on top of the air guide. See Fig. 10.

LUBRICATION

Breathers

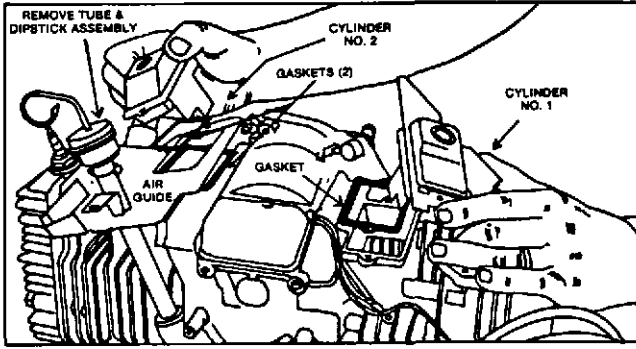

Fig. 10. Installing Breathers

Tighten screws to prevent oil leakage. Check to be sure venting tubes are not damaged or hard, and that they are sealing properly. Assemble intake manifold and carburetor assembly as shown in Sec. 3, page 2. Install breather tubes as shown in Fig. 11.

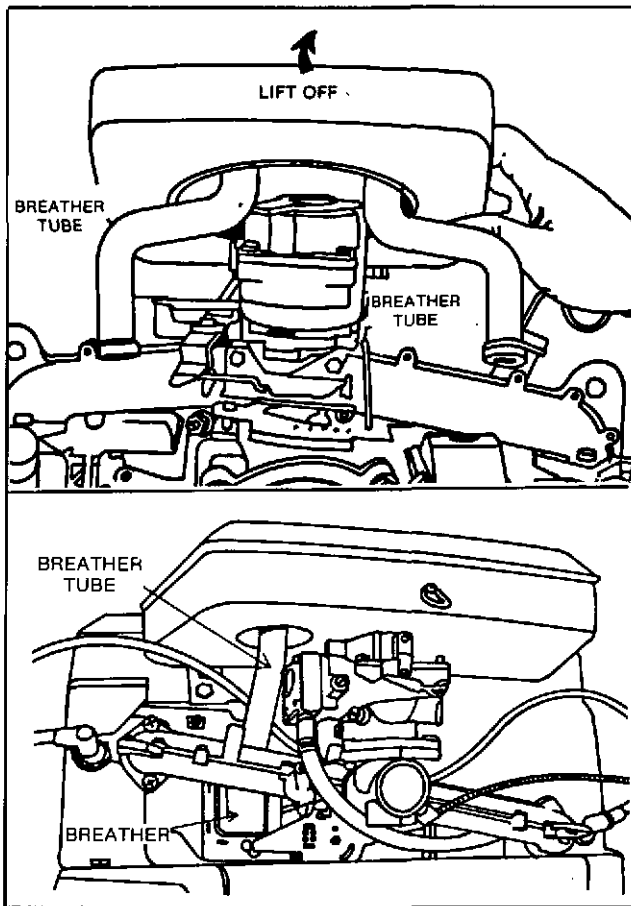

Fig. 11. Breather Tube Installation

OIL DIPPER MODEL SERIES 401400

In the splash system, the dipper dips into the oil reservoir in base of engine. It has no pump or moving parts.

Install the dipper on the number one (Magneto side) connecting rod as shown in Figure 12. Make sure piston and connecting rod assembly are installed exactly as they were removed. (See Section on Piston, Rings, and Rods.) Dipper must be assembled with a special washer located between the dipper and bolt.

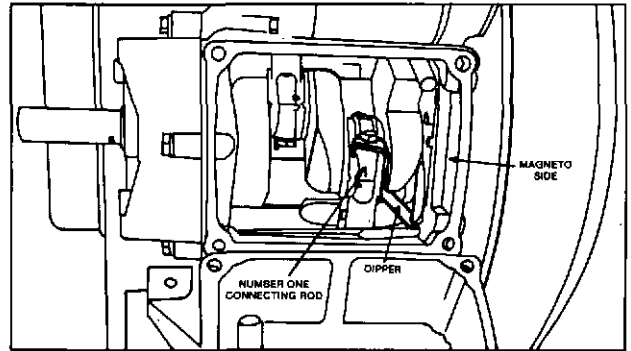

Fig. 12. Dipper Position

OIL SLINGER MODEL SERIES 401700

In the vertical crankshaft engine, a slinger is used, which moves the oil, using two paddles, which are gear driven by the cam gear. Fig. 13 and 14.

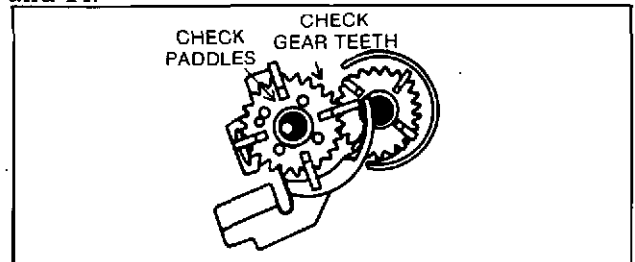

Fig. 13. Slinger Assembly

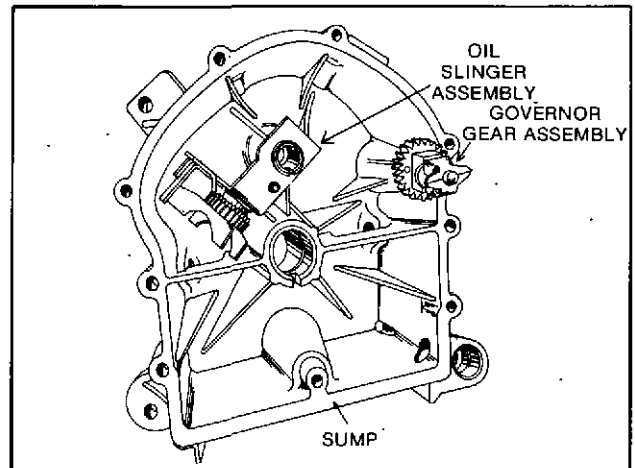

Fig. 14. Oil Slinger Location

Check the oil slinger. Check paddles and gear for damage, replace if necessary. See Fig. 13 and 14.

Section 9

PISTONS - RINGS - RODS

REMOVE PISTON AND CONNECTING ROD

To remove the piston and connecting rod from the engine, remove the connecting rod cap. Remove any carbon or ridge at the top of the cylinder bore; this will prevent breaking the rings. Push the piston and rod out through the top of the cylinder.

NOTE: Connecting rod locks are not used in twin cylinder engines. Special hardened washers are used under the rod cap screws.

CAUTION, be certain to keep each piston assembly and connecting rod and cap assembly in a set, to insure installing in the same cylinder. These parts are not interchangeable.

REMOVE CONNECTING ROD

To remove connecting rod from piston, remove piston pin lock with thin nose pliers. Fig. 1.

Remove rings one at a time as shown in Fig. 2. Use a ring expander to prevent damage to rings and piston.

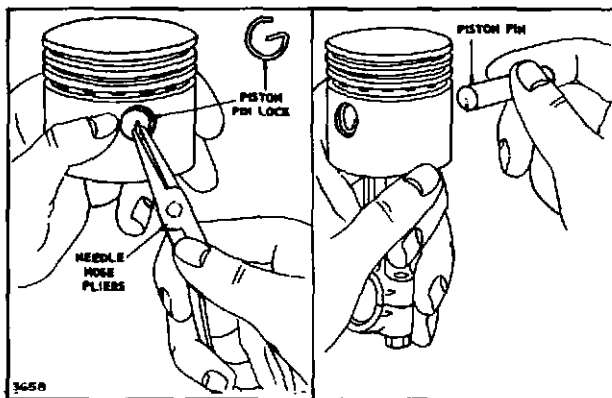

Figure 1. Removing Rod

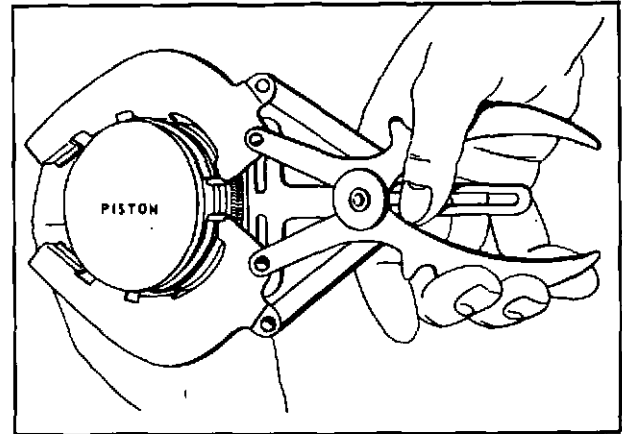

Figure 2. Removing Rings

CHECK PISTON

If the cylinder is to be resized, there is no reason to check the piston, since a new oversized piston assembly will be used.

If, however, the cylinder is not to be resized, and the piston shows no signs of wear or scoring, the piston should be checked.

To do so, clean carbon from top ring groove. Place a NEW ring on the groove, check the remaining space in the groove with a feeler gauge. Fig. 3. If a .007" feeler gauge can be inserted, (all models), the piston is worn and should be replaced.

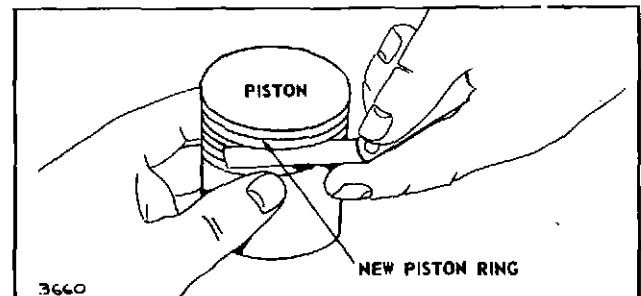

Figure 3. Checking Rings Grooves

PISTONS — RINGS — RODS

Checking

CHECK RINGS

To check rings, first clean all carbon from the ends of the rings and from the cylinder bore. Insert old rings one at a time one inch down into the cylinder. Check gap with feeler gauge. Fig. 4. If ring gap is greater than shown in Table No. 1, the ring should be rejected.

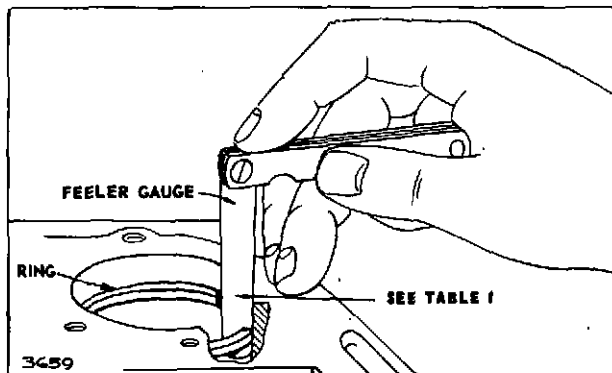

Figure 4. Checking Ring Gap

TABLE NO. 1
RING GAP REJECTION SIZE

BASIC MODEL SERIES	COMP. RING	OIL RING
401400 401700	.035	.045

NOTE: Do not deglaze cylinder walls when installing piston rings.

CHECK CONNECTING ROD

If the crankpin bearing in the rod is scored, the rod must be replaced. Rejection sizes of crankpin bearing hole and piston bearing hole are shown in Table No. 2. If the crankpin bearing in the connecting rod is worn, the rod should be replaced. Do not attempt to "file" or "fit" the rod.

CHECK PISTON PIN

If the piston pin is worn .0005" out of round it should be replaced.

TABLE NO. 2
CONNECTING ROD REJECT SIZES

BASIC MODEL SERIES	CRANK PIN BEARING	PISTON PIN BEARING
401400, 401700	1.627	.803

ASSEMBLE PISTON AND CONNECTING ROD

The piston pin is a slip fit in both piston and connecting rod.

Place a pin lock in the groove at one side of the piston. From the opposite side of the piston, insert the piston pin, until it stops against the pin lock. Fig. 1. Use a thin nose pliers to assemble the pin lock in the recessed end of the piston. Be sure the locks are firmly set in the grooves.

NOTE: Oil holes in connecting rods must face direction shown in Fig. 5.

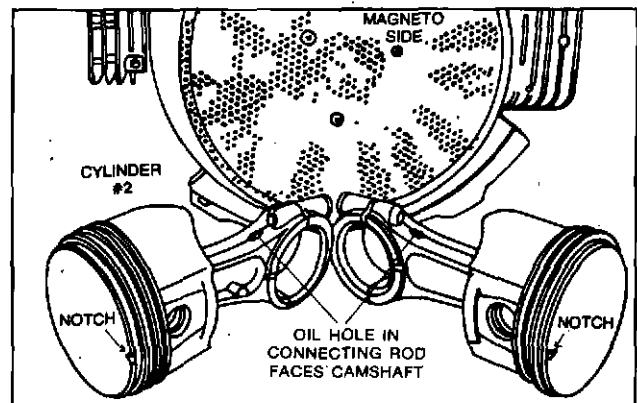

Figure 5. Connecting Rod Oil Hole Position

ASSEMBLE RINGS TO PISTON

The correct piston ring positions are shown in Fig. 6. The expander is installed under the oil ring. The second compression ring has a dot mark which must face direction shown.

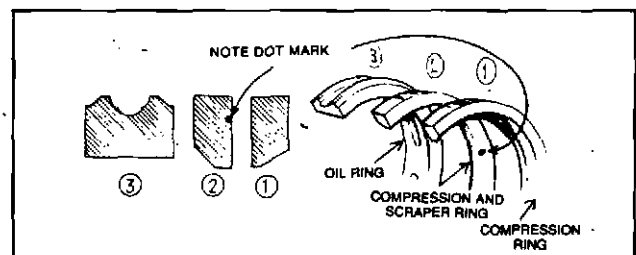

Figure 6. Piston Ring Installation

PISTONS — RINGS — RODS Assembly

INSTALLING PISTON AND CONNECTING ROD

Oil the rings and piston skirt, then compress rings with ring compressor (part 19070). Use compressor as shown in Fig. 7.

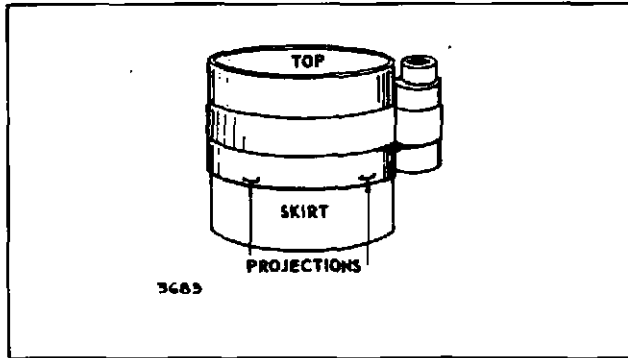

Figure 7. Compressing Rings

Turn the piston and compressor upside down on the bench and push downward, so the piston head and edge of compressor band are even while tightening the compressor. Draw the compressor up tight to fully compress the rings, then loosen the compressor very slightly.

Do not attempt to install piston and ring assembly without ring compressor.

NOTE: The pistons have a notch as shown in Fig. 8. The notch must face the flywheel side of the cylinder when installed.

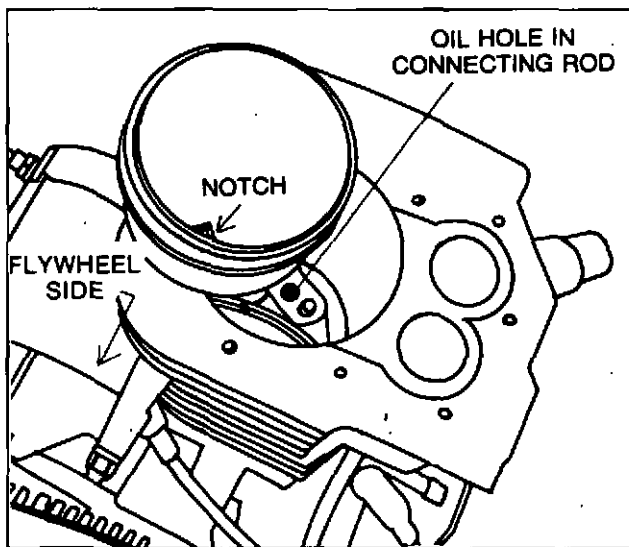

Figure 8. Installing Piston

Rotate the crankshaft so that the journal is at the bottom, to allow full entry when pushing the piston and connecting rod assembly into the cylinder. Clean and oil cylinder bore. Carefully, push the piston and rod into the cylinder. See Fig. 9.

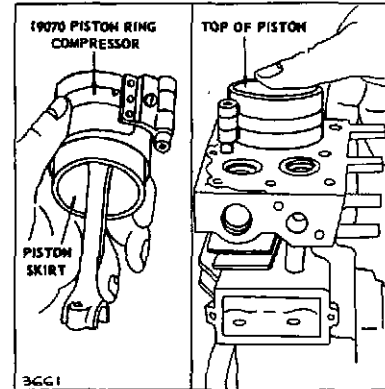

Figure 9. Install Piston Assembly

Oil the crankshaft crankpin. Pull the connecting rod against the crankpin and place the end caps so that the assembly marks align. Fig. 10. Install dipper on No. 1 (model 401400 only) connecting rod. **Screws must have hardened washers under screw heads before torquing.**

NOTE: Torque rod screws to 190 in.-Lbs. See Fig. 10. After torquing rod screws, the rod should be able to move sideways on the crankpin of the shaft. A **TORQUE WRENCH** must be used to prevent loose or overtight cap screws which results in breakage and/or scoring rod.

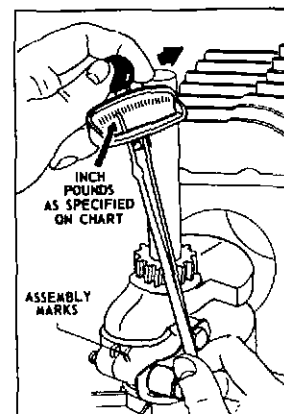

Figure 10. Torquing Connecting Rod

Section 10

CRANKSHAFTS & CAMGEARS

CRANKSHAFT REMOVAL

To remove the crankshaft first, remove rust or burrs from the power take-off end of the crankshaft. Remove crankcase cover or sump. If sump or cover sticks, tap lightly with soft hammer on alternate sides near dowel.

NOTE: If valves are installed, remove intake valves spring pressure by compressing springs as shown in Fig. 1.

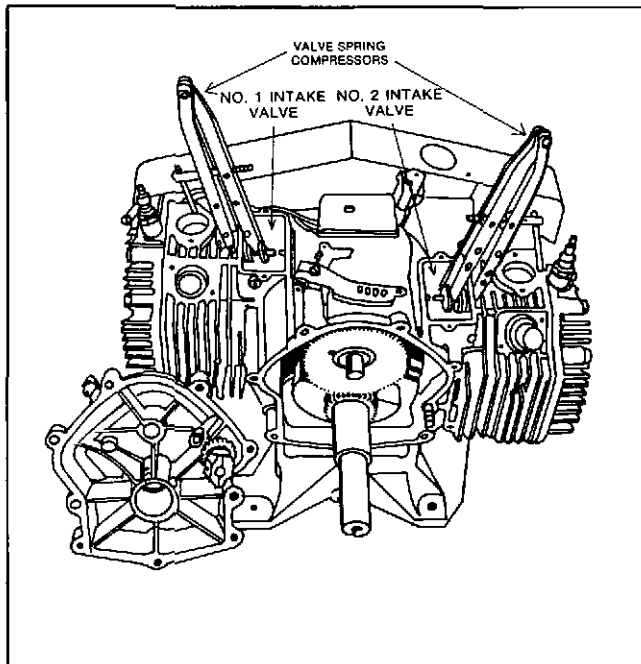

Figure 1. Crankcase Cover or Sump Removal

After cover is removed, note the timing mark at the cam gear and crankshaft gear. Fig. 2.

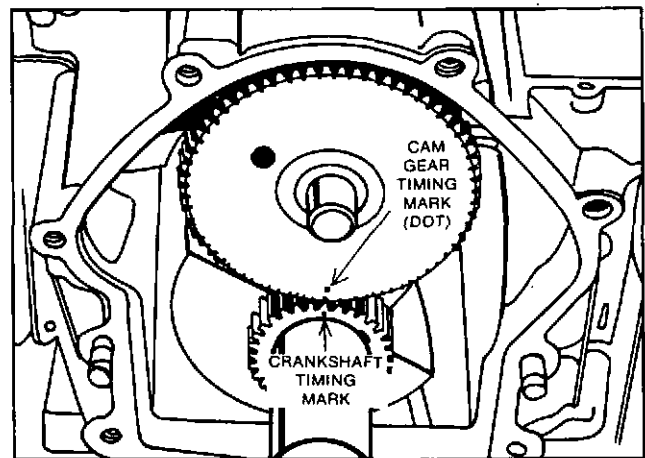

Figure 2. Timing Mark Location

NOTE: Tappets must clear cam lobes before cam gear can be removed.

CHECKING CRANKSHAFT

Table No. 1 shows the rejection sizes of the various wear points of the crankshaft. Discard crankshaft if worn smaller than the size shown. Keyways should be checked to be sure they are not worn or spread. Remove burrs from keyway edges to prevent scratching the bearing. Fig. 3 shows the various points to be checked on the crankshaft.

TABLE NO. 1
CRANKSHAFT REJECT SIZES

BASIC MODEL SERIES	P.T.O. JOURNAL	MAG. JOURNAL	CRANKSHAFT CRANKPINS
401700, 401400	1.376	1.376	1.622

CRANKSHAFTS & CAMGEARS

Checking

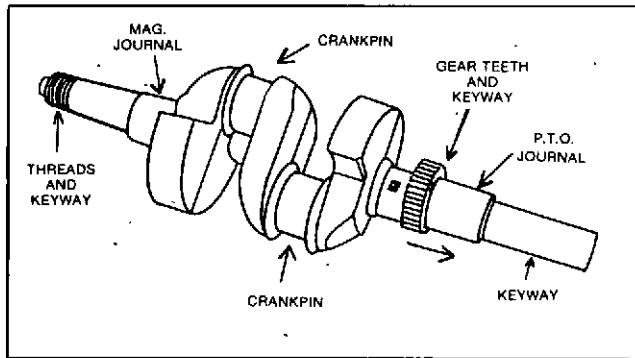

Figure 3. Crankshaft Check Points

CHECKING CAM GEAR

Inspect gear teeth for wear and nicks. Fig. 4. Cam gear and cam gear journals and lobe rejection sizes are shown in Table No. 2.

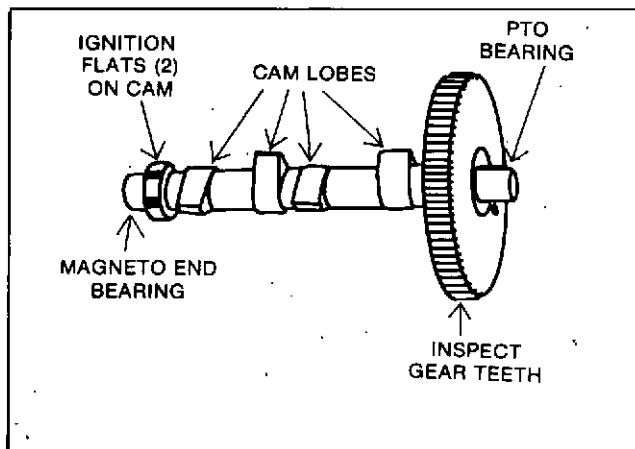

Figure 4. Camgear Check Points

TABLE NO. 2

BASIC MODEL SERIES	CAM GEAR OR SHAFT JOURNALS	CAM LOBES
401400, 401700	.623	1.124

INSTALL CRANKSHAFT AND CAM GEAR

Install crankshaft, then tappets. Next install cam gear. **Note: Tappets and breaker plunger must clear cam lobes.** Align timing marks as shown in Fig. 5.

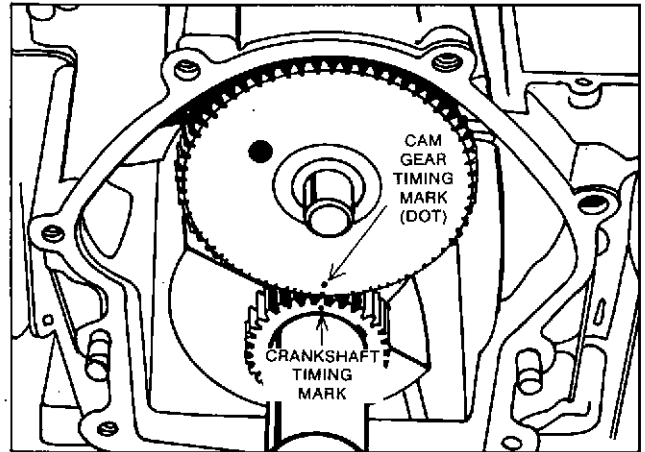

Figure 5. Timing Mark Location

NOTE: Governor shaft must be positioned as shown in Section 5 Page 3 Fig. 9 prior to installing crankcase cover.

CRANKCASE COVER AND CRANKSHAFT END PLAY

The crankshaft end play on all models should be .002" to .008". New gasket sets include three crankcase cover or sump gaskets - .005", .009", and .015" thick.

The end play should be .002" to .008" with one .015" gasket in place. If the end play is less than .002", which would be the case if a new crankcase or sump cover is used, additional gaskets of .005", .009", or .015" may be added in various combinations to attain the proper end play.

To protect the oil seal while assembling the crankcase cover, use oil or grease on the sealing edge of the oil seal. Wrap a piece of thin paper around the crankshaft so the seal will slide easily over the shoulder of crankshaft. If the sharp edge of the oil seal is cut or bent under, the seal may leak.

Section 11

CYLINDERS & BEARINGS

INSPECTION

All Models

Always inspect the cylinders after the engine has been disassembled. Visual inspection will show if there are any cracks, stripped bolt holes, broken fins, or if the cylinder wall is scored. Use a dial caliper and telescoping gauge to determine the size of the cylinder bore. Measure at right angles. (See Fig. 1.) Table No. 1 lists the standard cylinder bore sizes, on both cylinders.

If the cylinder bore is more than .003" oversize or .0025 out of round, it must be resized.

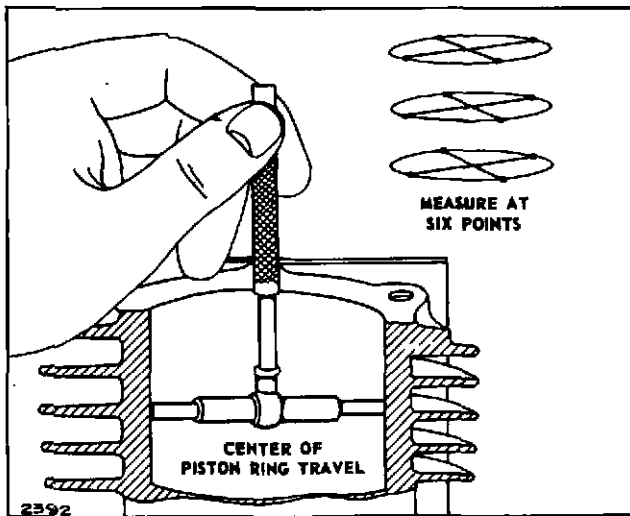

Fig. 1. Check Cylinder Bore

NOTE: Do not deglaze cylinder walls when installing piston rings in aluminum cylinder engines.

RESIZING

Resize Cylinder Bore to Next Oversize

ALWAYS RESIZE TO EXACTLY .010" or .020", or .030" OVER STANDARD SIZE AS SHOWN IN TABLE NO. 1. IF THIS IS DONE ACCURATELY, THE STOCK OVERSIZE RINGS AND PISTONS WILL FIT PERFECTLY AND PROPER CLEARANCES WILL BE MAINTAINED. Cylinders can be quickly resized with a good hone such as Briggs & Stratton part no. 19205. Contact your Briggs & Stratton source of supply. Use stones and lubrication recommended by the hone manufacturers for the various engine models, to produce the correct wall finish.

TABLE NO. 1

BASIC ENGINE MODEL OR SERIES	STD. BORE SIZE DIAMETER	
	MAX.	MIN.
ALUMINUM CYLINDER		
401417	3.4375	3.4365
401707	3.4375	3.4365

NOTE: An acceptable honing oil can be made by mixing 4 parts No. 30 oil with 1 part kerosene.

CYLINDERS

Resizing Bore

If a boring bar is used, a hone must be used after the boring operation to produce the proper cylinder wall finish.

Honing can be done with a portable electric drill, but it is easier to use a drill press.

To Set Up For Honing

Clean cylinder at top and bottom to remove burrs and pieces of base and head gaskets.

CYLINDER Resizing Bore

Fasten cylinder to a honing plate. Use a level to align drill press spindle with bore.

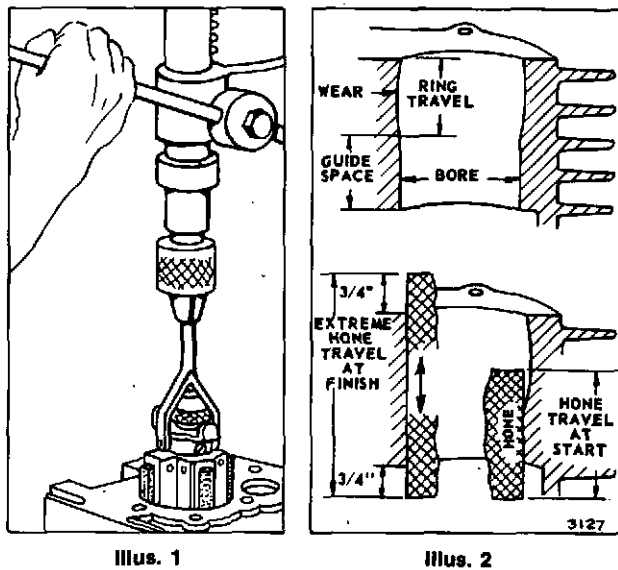

Figure 2

Oil surface of drill press table liberally. Set plate and cylinder on drill press table. (Do not anchor to drill press table). If using portable drill, set plate and cylinder on floor. Place hone drive shaft in chuck of drill or portable drill.

Slip hone into cylinder; Fig. 2. Illus. 1. Connect drive shaft to hone and set stop on drill press so hone can only extend 3/4" to 1" from top or bottom of cylinder. If using a portable drill, cut a wood block to place inside of cylinder as a stop for hone.

To Hone Cylinder

Place hone in middle of cylinder bore. Tighten adjusting knob with finger or small screwdriver until stones fit snugly against cylinder wall. **DO NOT FORCE.** Hone should operate at 300 to 700 RPM. Lubricate hone as recommended.

Connect drive shaft to hone. Be sure that cylinder and hone are centered and aligned with drive shaft and drill spindle. Start drill and, as hone spins, move it up and down at lower end of cylinder. Fig. 2. Illus. 2. The cylinder is not worn at the bottom but is round so it will guide the hone to straighten cylinder bore. As the bottom of the cylinder increases diameter, gradually increase strokes until hone travels full length of bore. Do not extend hone more than 3/4" to 1" at either end of cylinder bore.

As cutting tension decreases, stop hone and tighten adjusting knob. Check cylinder bore frequently with a dial caliper and telescoping gauge. Hone about .0005" large to allow for shrinkage when cylinder cools.

Change from rough stone to finishing stone when within .0015" of desired size, then use finishing stone. **ALWAYS HONE .010", or .020", or .030" ABOVE THE STANDARD DIMENSIONS GIVEN IN TABLE NO. 1.**

CYLINDER FINISH AND CLEANING

The finished resized cylinder should have a crosshatch appearance, Fig. 3. proper stones, lubrication and spindle speed along with rapid movement of hone within the cylinder during the last few strokes, will produce this finish. Crosshatching will allow proper lubrication and ring break-in.

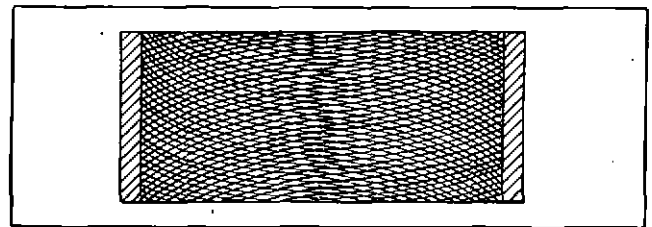

Fig. 3. Cross Hatch

IT IS MOST IMPORTANT THAT THE ENTIRE CYLINDER BE THOROUGHLY CLEANED AFTER HONING. WASH THE CYLINDER CAREFULLY IN A SOLVENT SUCH AS KEROSENE. THE CYLINDER BORE SHOULD THEN BE CLEANED WITH A BRUSH, SOAP, AND HOT WATER. DO NOT USE KEROSENE OR GASOLINE TO CLEAN THE BORE AS SOLVENTS OF THIS TYPE WILL NOT REMOVE ALL THE HONING GRIT.

TABLE NO. 2

CYLINDER BEARING REJECT SIZE CHART

BASIC ENGINE MODEL OR SERIES	PTO BEARING	BEARING MAGNETO
401400-401700	1.383	1.383

REPLACE OIL SEAL

The oil seal is assembled with the sharp edge of the rubber toward the inside of the engine. Lubricate inside diameter of oil seals with engine oil or equivalent, before assembling engines. Oil seals are pressed in, flush with the flange. Fig. 4.

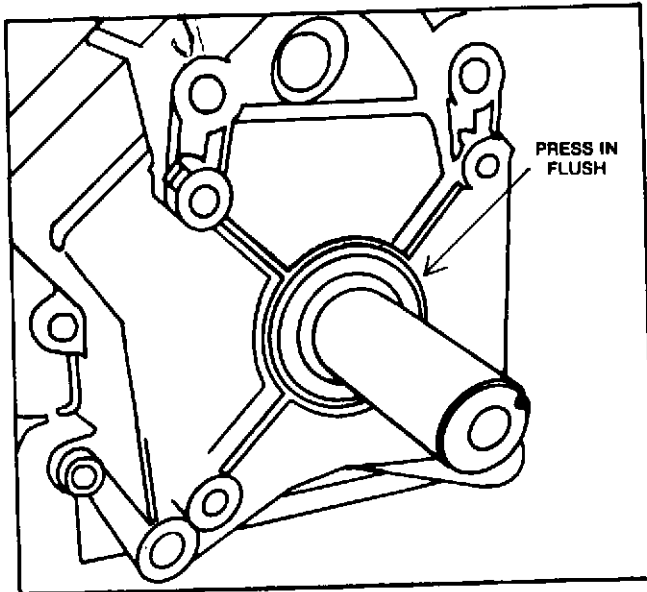

Fig. 4. Replacing Oil Seal

Section 12

MUFFLER

REMOVING MUFFLER AND BRACKET DUCTED ENGINES

To service the muffler, it is necessary to remove the muffler and mounting bracket assembly from the engine.

Remove the cylinder air guides first. See Fig. 1.

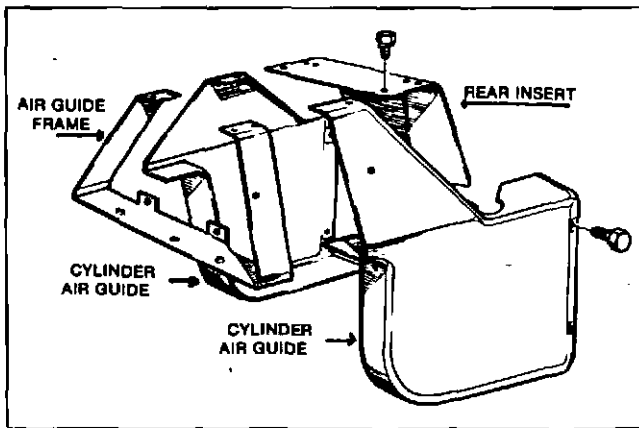

Fig. 1. Remove Screws

To remove the muffler, mounting bracket and air guide frame assembly from engine, remove the four large hex head screws. These screws are also used to secure the crankcase cover. See Fig. 2.

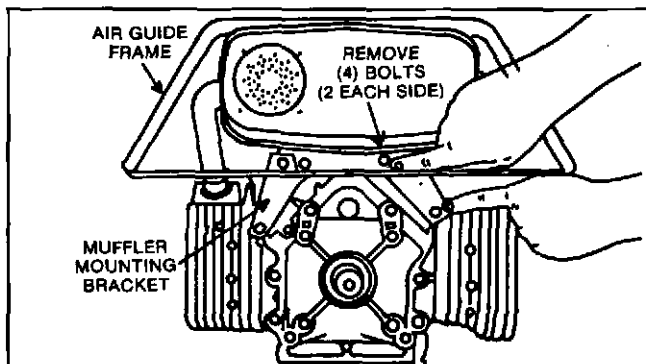

Fig. 2. Bracket Location Screws

NOTE: There are no clamps used to hold muffler pipes to the exhaust nipples. Fig. 3.

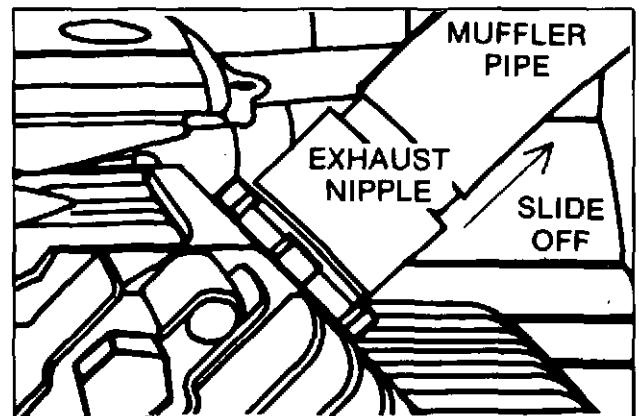

Fig. 3. Remove Muffler Pipe From Nipple

The muffler mounting bracket and muffler is a two piece assembly along with the air guide frame, and should easily lift off the engine cylinder. Fig. 4.

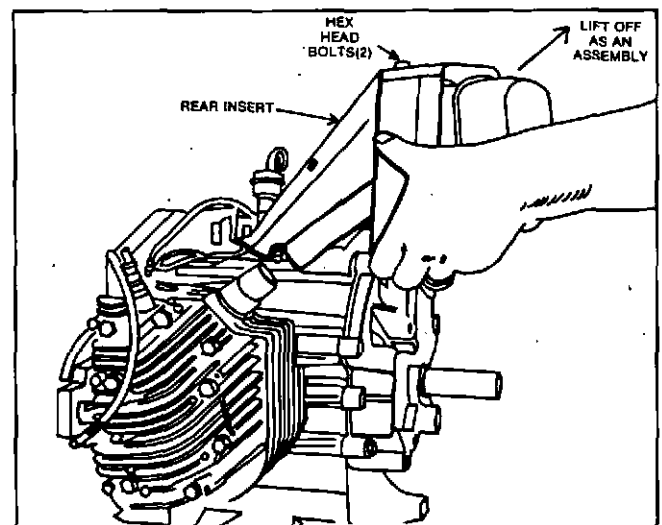

Fig. 4. Removing Muffler Assembly

If the exhaust pipes appear to be "frozen" on the nipples, apply a small amount of penetrating oil to the connections. Do not use unnecessary force on the muffler pipes when removing the assembly, or they could become damaged or distorted.

MUFFLER Inspection

INSPECTION OF MUFFLER AND BRACKET

Check the muffler mounting bracket for cracks and/or breakage. Check muffler for distortion and/or loose internal parts. Loss of power could develop if muffler has loose internal parts restricting the exhaust flow. Check for breaks in the seams, and check weld at the junction of the exhaust pipe and muffler. Fig. 5.

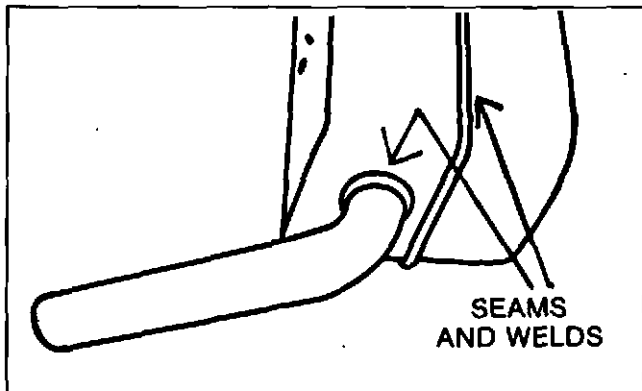

Fig. 5. Checking Muffler

Inspect muffler exhaust nipples for damage or looseness. Replace if necessary. Loosen locknut first. Then unscrew nipple. Use penetrating oil if necessary, to prevent galling aluminum threads. Fig. 6.

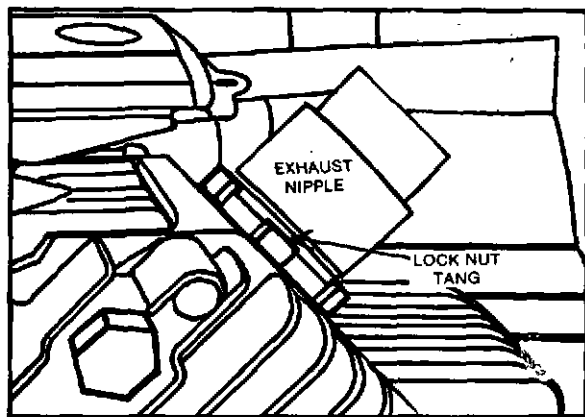

Fig. 6. Muffler Nipple

DISASSEMBLY OF MUFFLER AND BRACKET

Remove the four bolts that attach the muffler to the bracket. Use penetrating oil if necessary to prevent breaking the threaded portion of the screw in the muffler. Fig. 7.
To disassemble air guide frame from the muffler bracket, remove two small hex head screws.

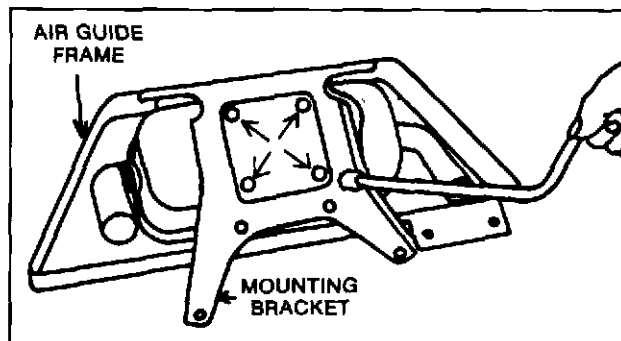

Fig. 7. Remove Mounting Bracket from Muffler

REASSEMBLY: EXHAUST SYSTEM

When installing the exhaust nipples, lubricate the threaded portion with a graphite lubricant (i.e. Lead Plate 250). Install lock nut with tang away from cylinder as shown in Figure 6 to prevent damage to the cylinder or loosening of the nipple during operation. Tighten lock nut securely. A maximum of two threads should be exposed after assembly.

If the muffler and bracket were separated, first place the muffler on the bracket and install (do not tighten) hex head screws. Mount the assembly to the engine aligning the muffler pipes and the exhaust nipples. Locate the muffler bracket on the crankcase cover, and insert the four long, hex head bolts and tighten. Secure the muffler to the bracket by torquing the four small hex head screws: (80 In-Lbs.) CAUTION: DO NOT OVER TORQUE. Fig. 8.

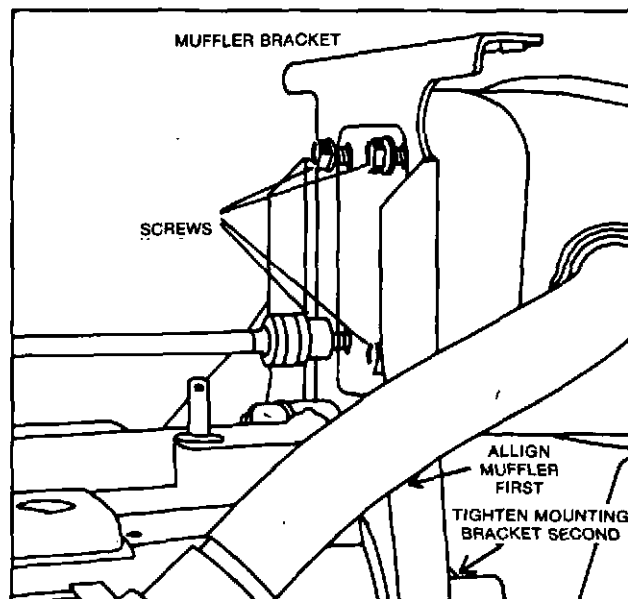

Fig. 8. Installing Muffler and Bracket

MUFFLER Assembly

Replace the air guide frame and rear insert. (see Fig. 1. Page 1) Install the cylinder head cover and tighten hex head screws to the proper torque specs. Make sure the four bolts that secure the muffler brackets to the cylinder cover are torqued properly to 80 In-Lbs.

REMOVING MUFFLER VERTICAL CRANKSHAFT ENGINE

The disassembly procedure for the vertical shaft engine is similar to that of the horizontal. Fig. 9.

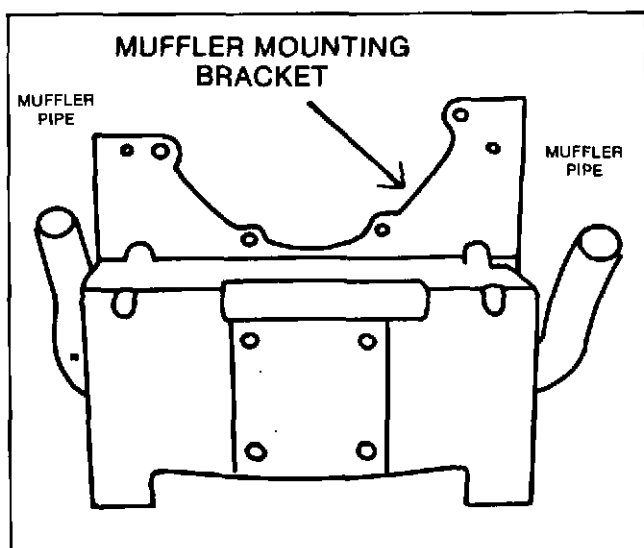

Fig. 9. Muffler and Bracket Assembly

When replacing the exhaust deflector on the vertical crankshaft muffler, make sure that the deflector is pointed outward to prevent restriction of the exhaust. (See Figure 10).

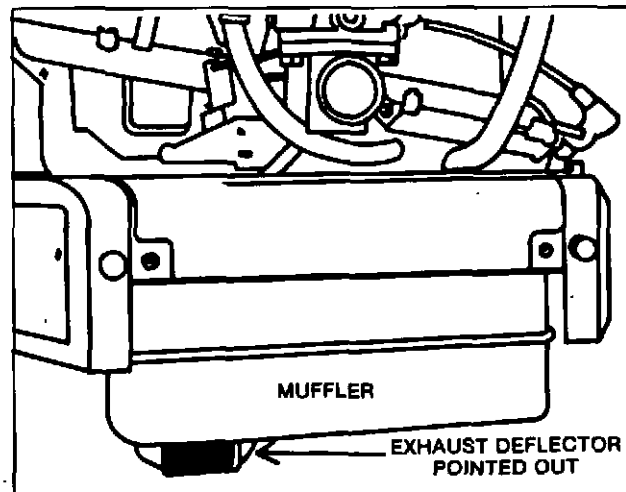

Fig. 10. Exhaust Vertical Crankshaft Engine Deflector Location

SPARK ARRESTER EQUIPPED MUFFLER

If the engine has a spark arrester screen assembly inspection of the spark arrester screen assembly is necessary. Remove every 50 hours for cleaning and inspection. If the screen is clogged or damaged, replacement is necessary. See Service Bulletin No. 514.

Section 13

TOOLS

It is assumed that Authorized Briggs & Stratton Service Centers have all common tools needed to repair engines.

Specialized tools in addition to the Briggs & Stratton 291661 Tool Kit, are required to analyze, repair and restore engines to proper operating condition.

The following tachometers have been found to work well on Briggs & Stratton engines:

TYPE	NAME	R.P.M. RANGE	SOURCE
Vibration	Trysit Sirometer	800-25000	Order from your Briggs & Stratton Source of Supply-Part No. 29100
Vibration	Frahm #2516	1000-4000	James G. Biddle Co. Plymouth Meeting, Pa. 19462
Electronic	Merc-O-Tronic Model 67-100T	1000-5000 1000-10000	Merc-O-Tronic Instruments Corp. 215 Branch Street Almont, Michigan

Note: Product brand names are given in some instances. However, any tool or test instrument of equivalent accuracy is acceptable in the following list.

DESCRIPTION	RANGE OR TYPE	SOURCE
Torque Wrench	0-200 in. Lbs.-Part No. 19197	Briggs & Stratton Source
Valve Guide Tools		
Reamer	19183	Briggs & Stratton Source
Guide	19192	" " "
Guide	19191	" " "
Valve Seat Refacer	Neway No. 102W	Neway Sales, Inc. Corunna, Mich. 48817 or Briggs & Stratton Source
Valve Lapper	Woods Powr-Grip	Woods Powr-Grip Manufacturer 233 Cascade Wolf Point, Montana
Dial Caliper	0-4 in.-Part No. 19199	Briggs & Stratton Source
Telescope Gauge	2-1/8 3-9/16"—Part No. 19198	Briggs & Stratton Source
Electronic Multimeter or Voltmeter, Ohmmeter Ammeter	0-15 Volt D.C. 0-150 Volt D.C. and A.C. 0-1000 Ohms 0-15 Amps A.C. and D.C.	Local Electronic Parts Supply
Ignition Timing Light	Merc-O-Tronic Model 701 FCT	Briggs & Stratton Source

TOOLS

BRIGGS & STRATTON REPAIR TOOLS See Price List MS-4695 in Section one of the Master Parts Manual

Tools are listed by description and by kits. Kit 291661 is a requirement of the Authorized Registered Service Dealer.

NOTE: 291661 Tool Kit is recommended for Public Schools conducting air cooled engine courses.

PART NO.	DESCRIPTION	MODEL OR SERIES USED ON
Plug Gauges		
19055	Check Breaker Plunger Hole	5, 6, 8, N, 100000, 130000, 140000, 170000, 190000, 251000, 23C,*
19122	Check Valve Guide	5, 6, 8, N, 100000, 110900, 130000,*
19151	Check Valve Guide	9, 14, 19, 23, 140000, 170000, 190000, 251000, 200000, 230000, 240000, 300000, 320000, 401000
19164	Check Camshaft Bearings	100000, 130000, 140000, 170000, 190000, 251000,*
19166	Check Main Bearings	5, 6, 8, N, 100000, 130000,*
19178	Check Main Bearings	140000, 170000, 190000
Reamers		
19056	Breaker Plunger Bushing Reamer	5, 6, 8, N, 100000, 130000, 140000, 170000, 190000, 251000,*
19058	Finish Reamer for Breaker Plunger	5, 6, 8, N, 100000, 130000, 140000, 170000, 190000, 251000,*
19064	Valve Guide Bushing Reamer	5, 6, 8, N, 100000, 130000,*
19066	Finish Reamer Valve Guide	5, 6, 8, N, 100000, 130000,*
19095	Finish Reamer for Main Bearing	5, 6, 8, N, 100000, 130000,*
19099	Counterbore for Main Bearings	100000, 130000,*
19172	Counterbore for Main Bearings	100000, 130000, 140000, 170000, 190000
19173	Finish Reamer for Main Bearings	100000, 130000, 140000, 170000, 190000
19174	Counterbore for Main Bearings	140000, 170000, 190000
19175	Finish Reamer for Main Bearings	140000, 170000, 190000
19183	Valve Guide Bushing Reamer	9, 14, 140000, 170000, 19, 190000, 251000, 200000, 23, 230000, 240000, 300000, 320000, 401000
Pilots		
19096	Main Bearing Reamer Pilot	5, 6, 8, N, 100000, 130000, 140000, 170000, 190000,*
19126	Exp. Pilot for Valve Seat Counterbore	5, 6, 8, N, 100000, 130000,*
19127	Exp. Pilot for Valve Seat Counterbore	9, 14, 19, 190000, 200000, 23, 230000, 240000, 300000, 320000
Drivers		
19057	Install Plunger Bushing	5, 6, 8, N, 100000, 130000, 140000, 170000, 190000, 251000,*
19065	Install Valve Guide Bushings	5, 6, 8, N, 100000, 130000,*
19124	Install Main Bearings	5, 6, 8, N, 100000,*
19136	Install Valve Seat Inserts	All Models and Series
19179	Install Main Bearings	140000, 170000, 190000

*Includes 6B, 8B, 60000, 80000, 82000, 92000, 110000 Series

BRIGGS & STRATTON REPAIR TOOLS (Continued)

PART NO.	DESCRIPTION	MODELS OR SERIES USED ON
Guide Bushings		
19094	Guide Bushing for Main Bearing Reaming	5, 6, 8, N, 100000, 130000,*
19097	Guide Bushing for Ball Bearing Cover	5, 6, 8, N, 100000, 130000,*
19100	Guide Bushing for Main Bearing Reaming	*
19101	Guide Bushing for Main Bearing Reaming	100000, 130000,*
19168	Guide Bushing for Main Bearing Reaming	100000, 130000, 140000, 170000, 190000
19169	Guide Bushing for Main Bearing Reaming	140000, 170000, 190000
19170	Guide Bushing for Main Bearing Reaming	100000, 130000, 140000, 170000, 190000
19171	Guide Bushing for Main Bearing Reaming	140000, 170000, 190000
19186	Guide Bushing for Main Bearing Reaming	100000, 130000
19191	Guide Bushing for Valve Guide Reaming	5, 6, 8, N, 100000, 130000,*
19192	Guide Bushing for Valve Guide Reaming	9, 14, 140000, 170000, 19, 190000, 200000, 251000, 23, 230000, 240000, 300000, 320000, 401000
19201	Guide Bushing for Main Bearing Reaming	171000, 191000
Counterbore Cutters		
19115	Counterbore Valve Guide Hole	5, 6, 8, N, 100000, 130000,*
19131	Counterbore Valve Insert Hole	14, 19, 190000, 200000, 23, 230000
19132	Counterbore Valve Insert Hole	8, 9
19133	Counterbore Valve Insert Hole	5, 6, N
Crankcase Support Jack		
19123	To Support Crankcase for Removing and Installing Main Bearings	5, 6, 8, N, 100000, 130000, 140000, 170000, 190000.*
Flywheel Pullers		
19052	Removal of Flywheel	ZZ
19053	Removal of Flywheel	A, B
19069	Removal of Flywheel	*
19165	Removal of Flywheel	140000, 170000, 190000, 251000
19203	Removal of Flywheel	9, 14, 19, 190000, 200000, 23, 230000, 240000, 251000, 300000, 320000
93029	Self Threading Screw for Flywheel Pullers	*, 140000, 170000, 190000, 251000, 401000
Flywheel Holder		
19114	To hold Flywheel while loosening or tightening nut	*
Starter Clutch Wrench		
19167	For Removal and Installation of Starter Clutch	All Models with Recoil Starters
19161	For Removal and Installation of Starter Clutch (To be used with socket or torque wrench)	All Models with Recoil Starters
Valve Spring Compressor		
19063	To Compress Valve Springs	All Models and Series
Piston Ring Compressor		
19070	To Compress Rings on Piston	All Models and Series
Spark Tester		
19051	For Testing Ignition Spark	All Models and Series

*Includes 6B, 8B, 60000, 80000, 82000, 92000, 110000 Series

TOOLS

BRIGGS & STRATTON REPAIR TOOLS (Continued)

PART NO.	DESCRIPTION	MODELS OR SERIES USED ON
----------	-------------	--------------------------

Valve Seat Repair Tools

19126	Pilot for Valve Seat Counterbore	5, 6, 8, N, 100000, 130000,*
19127	Pilot for Valve Seat Counterbore	9, 14, 140000, 170000, 190000, 200000, 23, 230000, 240000, 300000, 320000, 401000
19129	Cutter Shank-Driver for Counterbore	All Models and Series
19130	T Handle-For Cutter Shank	All Models and Series
19131	Counterbore Cutter-For Valve Seats	14, 19, 190000, 200000, 23, 230000
19132	Counterbore Cutter-For Valve Seats	8, 9
19133	Counterbore Cutter-For Valve Seats	5, 6, N
19135	Knockout Pin-Remove Shank from Cutter	All Models and Series
19136	Insert Driver-Install Valve Seats	All Models and Series
19137	T Handle for Exp. Pilots	All Models and Series
19138	Insert Puller-To remove Valve Seats	Includes 19139, 19140, 19141, 19182
19140	Puller Nut-To remove Valve Seats	9
19141	Puller Nut-To remove Valve Seats	5, 6, 8, N, 100000, 130000,*
19182	Puller Nut-To remove Valve Seats	14, 140000, 170000, 190000, 200000, 23, 230000, 240000, 300000, 320000, 401000

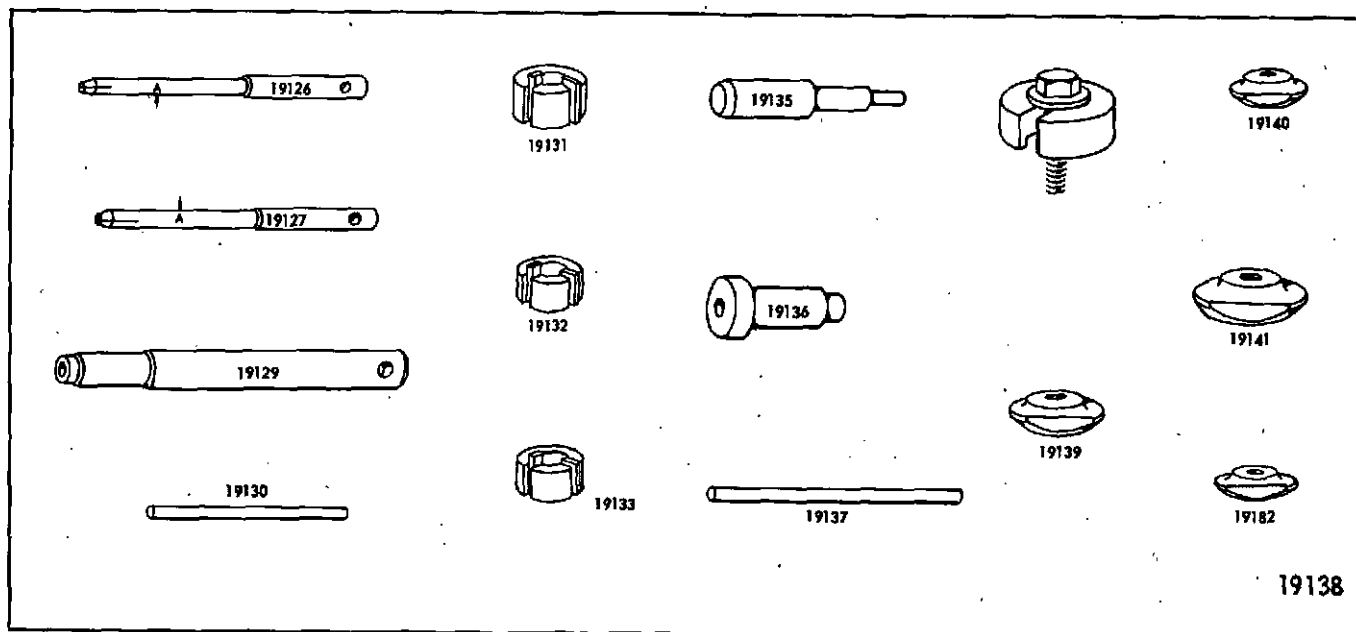

Tool Kits

19158	Main Bearing Kit	5, 6, 8, N, 100000, 130000,*
19184	Main Bearing Kit	100000, 130000, 140000, 170000, 190000, 191000
291661	Service Dealer Kit	Basic Kit (Used with All Models)

*Includes 6B, 8B, 60000, 80000, 82000, 92000, 110000 Series

291661 TOOL KIT

PART NO.	DESCRIPTION	SERIES USED ON
19051	Spark Tester	All Models
19055	Breaker Plunger Gauge	*, 140000, 170000, 190000, 251000, 23C
19056	Plunger Bushing Counterbore Reamer	*, 140000, 170000, 190000, 251000, 23C
19057	Plunger Bushing Driver	*, 140000, 170000, 190000, 251000, 23C
19058	Plunger Bushing Finish Reamer	*, 140000, 170000, 190000, 251000, 23C
19061	Screw Driver	All Models
19062	Screw Driver	All Models
19063	Spring Compressor	All Models
19064	Valve Guide Bushing Counterbore Reamer	*
19065	Valve Guide Bushing Driver	*
19066	Valve Guide Bushing Finish Reamer	*
19069	Flywheel Puller	*
19070	Ring Compressor	All Models
19114	Starter Clutch Wrench	All Rewind Starters
19122	Valve Guide Reject Gauge	*
19151	Valve Guide Reject Gauge	9, 14, 19, 140000, 170000, 190000, 251000, 200000, 23, 230000, 240000, 300000, 401000, 140000, 170000, 190000, 251000
19165	Flywheel Puller	*
19167	Flywheel Holder	*
19191	Reamer Guide Bushing	All Cast Iron Models, 251000, 401000
19203	Flywheel Puller	
*Includes 6, 8, 6B, 80000, 82000, 92000, 100000, 110000, 130000 Series		

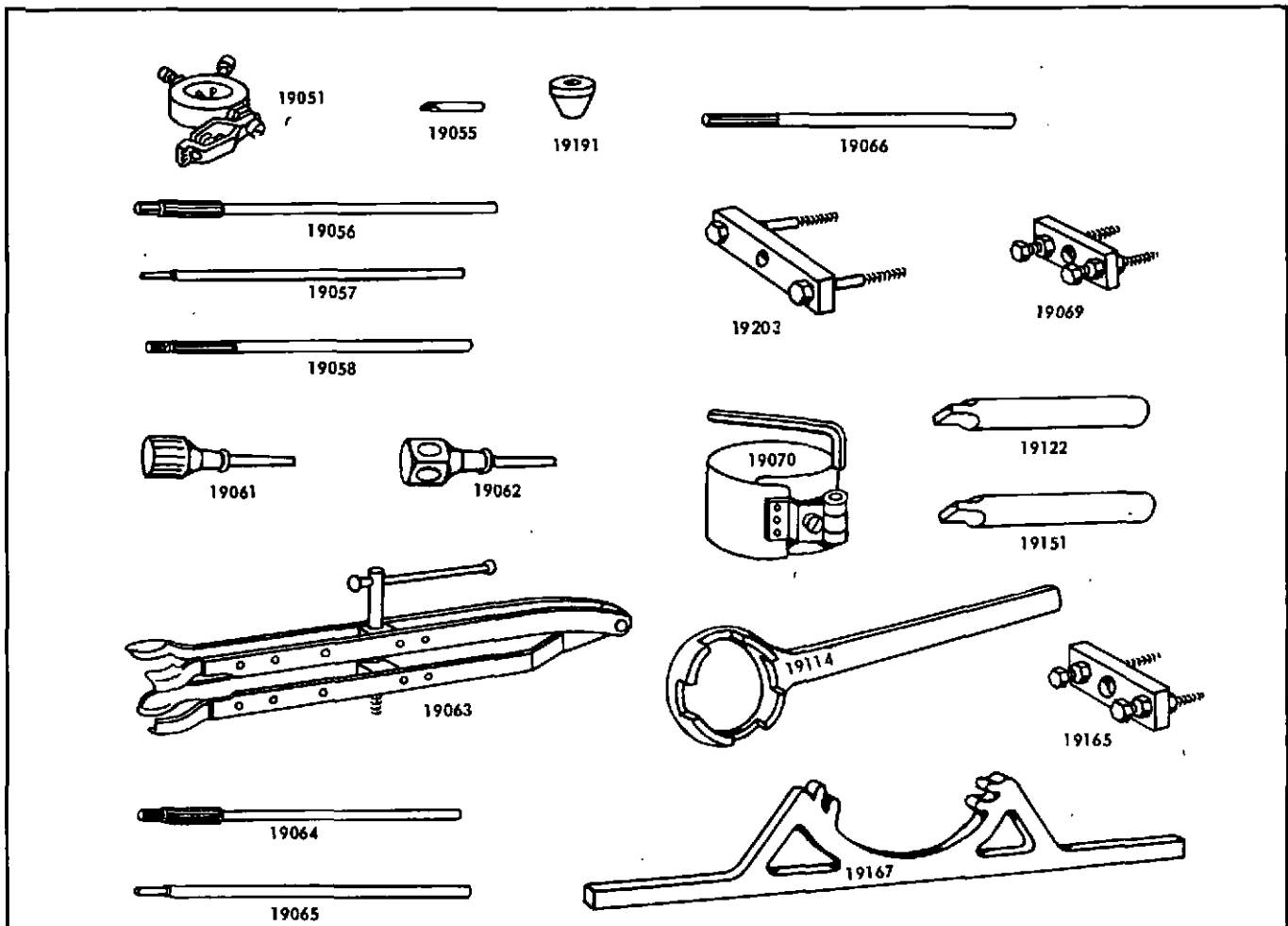

TOOLS

CYLINDER RESIZING EQUIPMENT

PLEASE NOTE: Part number 19205 Hone Set covers all aluminum cylinder engines.

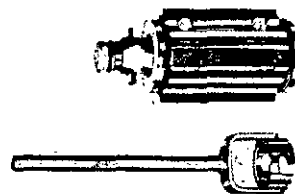
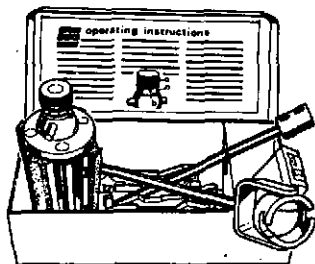

Part number 19205 Hone Set (aluminum cylinder engines) Range 1-7/8" to 3-1/2"

Replacement parts for Part number 19205 Hone Set

Part number 19206	Stone Set	(Range 1-7/8" to 2-3/4")
Part number 19207	Stone Set	(Range 2-5/8" to 3-1/2")
Part number 19208	Stone Retainer Springs	
Part number 19209	Drive Shank	
Part number 19210	Stop	

Each cylinder hone set contains instructions covering cylinder honing procedures. We also suggest you review your Briggs & Stratton Repair Instruction (Section 11) for all standard cylinder bore sizes.



PART NO. 271172

Litho in U.S.A.