

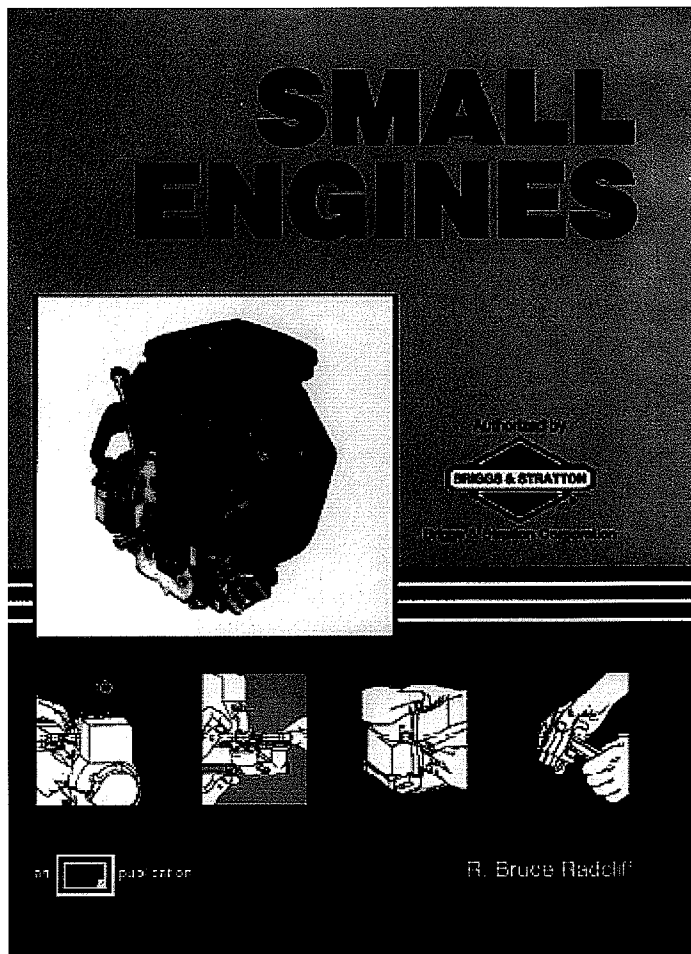

VANGUARD

Repair Manual
For VANGUARD™ V-Twin Overhead Valve



A comprehensive hard cover textbook titled *Small Engines* was recently published by American Technical Publication of Homewood, Illinois. The text was authored by R. Bruce Radcliff, Customer Education Director for Briggs & Stratton. This entirely new book is authorized by Briggs & Stratton, the world's largest manufacturer of small air cooled engines.

In addition to covering all aspects of small engine theory, the subjects of shop safety, tools, troubleshooting and engine emissions are featured.

The book contains 12 chapters covering the basic principles of small engine operation and service through engine theory to electricity and failure analysis. The book goes far beyond the procedures in the repair manual to present the "Why" in engine design features and operation fundamentals.

Included are current high priority topics such as engine oil, reformulated fuels, engine emissions as well as the latest information on engine application.

Fully illustrated, using computer generated line art and photographs, each topic is covered in easy to understand terms and four color illustrations.

This should be a standard reference book for all small engine repair facilities, vocational schools and consumers.

Small Engines is available through any Briggs & Stratton source of supply.

Order Part Number CE8020

TABLE OF CONTENTS

Also See Section Reference (By Subject)

| | |
|--|------------|
| GENERAL INFORMATION | Section 1 |
| IGNITION | Section 2 |
| CARBURETION | Section 3 |
| GOVERNOR CONTROLS & GOVERNOR | Section 4 |
| CYLINDER HEAD & VALVES | Section 5 |
| STARTERS | Section 6 |
| ALTERNATORS | Section 7 |
| LUBRICATION | Section 8 |
| ENGINE DISASSEMBLY | Section 9 |
| CYLINDER & CRANKCASE COVER – INSPECTION & REPAIR ... | Section 10 |
| CRANKSHAFT & CAM SHAFT | Section 11 |
| PISTON, RINGS & CONN. ROD INSPECTION & REPAIR | Section 12 |
| ENGINE ASSEMBLY | Section 13 |
| TOOLS | Section 14 |

1

2

3

4

5

6

7

8

9

10

11

12

13

14

SPECIFICATIONS FOR ALL VANGUARD™ OHV

Common Specifications – All Models

| | |
|------------------------|--------------------------------|
| Armature Air Gap | .008" – .012" (0.20 – 0.30 mm) |
| Crankshaft End Play | .003" – .015" (0.08 – 0.40 mm) |
| **Governed Idle Speed | |
| Spring #805453 (red) | 1750 RPM |
| Spring #805454 (white) | 1100 RPM |
| Spark Plug Gap | .030" (.76 mm) |
| Valve Clearance (Cold) | |
| Intake | .004" – .006" (0.10 – 0.15 mm) |
| Exhaust | .004" – .006" (0.10 – 0.15 mm) |

** Top Governed Speed: See Briggs & Stratton Service Engine Sales Manual Microfiche MS-6255 or Sales Manual MS-4052.

Common Torque Specifications – All Models

| | |
|------------------------------------|-------------------------|
| Alternator (to cylinder) | 2.0 Nm (20 in. lbs.) |
| Air Cleaner Base (to carburetor) | 7.0 Nm (65 in. lbs.) |
| Air Cleaner Support Bracket | 7.0 Nm (65 in. lbs.) |
| Armature | 3.0 Nm (25 in. lbs.) |
| Back Plate | 7.0 Nm (65 in. lbs.) |
| Blower Housing | 7.0 Nm (65 in. lbs.) |
| Breather | 3.0 Nm (30 in. lbs.) |
| Carburetor (to manifold) | 7.0 Nm (65 in. lbs.) |
| Connecting Rod | 13.0 Nm (115 in. lbs.) |
| Crankcase Cover | 17.0 Nm (150 in. lbs.) |
| Cylinder Head | 19.0 Nm (165 in. lbs.) |
| Cylinder Shield | 7.0 Nm (65 in. lbs.) |
| Exhaust Manifold | 17.0 Nm (150 in. lbs.) |
| Fan Retainer | 17.0 Nm (150 in. lbs.) |
| Flywheel | 175.0 Nm (125 ft. lbs.) |
| Governor Control Bracket | 16.0 Nm (140 in. lbs.) |
| Governor Lever Nut | 8.0 Nm (70 in. lbs.) |
| Intake Manifold | 16.0 Nm (140 in. lbs.) |
| Oil Pump | 7.0 Nm (65 in. lbs.) |
| Rewind Starter (to blower housing) | 7.0 Nm (60 in. lbs.) |
| Rocker Arm Lock Nut | 7.0 Nm (60 in. lbs.) |
| Rocker Arm Stud | |
| – Current Style | 11.0 Nm (100 in. lbs.) |
| – Early Style | 16.0 Nm (140 in. lbs.) |
| Spark Plug | 23.0 Nm (200 in. lbs.) |
| Starter Motor | 16.0 Nm (140 in. lbs.) |
| Starter Motor Thru Bolts | 6.0 Nm (50 in. lbs.) |
| Valve Cover | 3.0 Nm (25 in. lbs.) |

V-TWIN CYLINDER ENGINE MODELS

Standard And Reject Dimensions – All Models

| DESCRIPTION | STANDARD DIMENSION | REJECT DIMENSION |
|------------------------------------|--------------------------------------|--------------------|
| Cylinder | | |
| Bore | | |
| – Model 29000 & 303000 | 68.0 – 68.03 mm (2.677" – 2.678") | 68.10 mm (2.681") |
| – Model 350000 & 351000 | 72.0 – 72.03 mm (2.835" – 2.836") | 72.16 mm (2.839") |
| – Model 380000 | 75.50 – 75.52 mm (2.9724" – 2.973") | 75.59 mm (2.976") |
| Out of round: | | 0.04 mm (.0015") |
| Main Bearing (Before 970501100) | 30.03 – 30.06 mm (1.1825" – .1835") | 30.08 mm (1.1845") |
| (After 97043000) | 35.02 – 35.06 mm (1.379" – 1.3805") | 35.12 mm (1.383") |
| Cam Bearing | 16.0 – 16.03 mm (.630" – .631") | 16.08 mm (.633") |
| Cylinder Head | | |
| Valve Guide | 6.01 – 6.02 mm (.2365" – .237") | 6.05 mm (.238") |
| Valve Stem – Intake | 5.95 – 5.96 mm (.234" – .2346") | 5.92 mm (.233") |
| – Exhaust | 5.94 – 5.95 mm (.2338" – .234") | 5.91 mm (.2328") |
| Crankcase Cover | | |
| Main Bearing | 35.04 – 35.05 mm (1.3795" – 1.380") | 35.07 mm (1.381") |
| Cam Bearing | 20.0 – 20.02 mm (.7875" – .788") | 20.04 mm (.789") |
| Crankshaft | | |
| Crankpin | 37.0 – 37.02 mm (1.4565" – 1.4575") | 36.95 mm (1.455") |
| Magneto Journal (Before 97050100) | 29.98 – 30.0 mm (1.180" – 1.181") | 29.94 mm (1.179") |
| (After 97043000) | 34.99 – 35.01 mm (1.3776" – 1.3784") | 34.95 mm (1.376") |
| PTO Journal | 34.96 – 34.97 mm (1.3765" – 1.377") | 34.92 mm (1.375") |
| Cam Shaft | | |
| Magneto Journal | 15.95 – 15.97 mm (.628" – .6287") | 15.93 mm (.6273") |
| PTO Journal | 19.94 – 19.96 mm (.7855" – .786") | 19.92 mm (.7845") |
| Lobes | | |
| Models 290000 – 351000 – Intake | 30.33 – 30.53 mm (1.194" – 1.202") | 30.25 mm (1.191") |
| – Exhaust | 30.33 – 30.53 mm (1.194" – 1.202") | 30.25 mm (1.191") |
| Model 380000 – Intake | 31.09 – 31.30 mm (1.224" – 1.232") | 31.06 mm (1.223") |
| – Exhaust | 30.33 – 30.53 mm (1.194" – 1.202") | 30.25 mm (1.191") |
| Connecting Rod | | |
| Crankpin Bearing ALL | 37.06 – 37.08 mm (1.459" – 1.460") | 37.12 mm (1.4615") |
| Piston Pin Bearing | | |
| Models 290000 – 352000 | 17.09 – 17.1 mm (.6728" – .6735") | 17.12 mm (.674") |
| Model 380000 | 18.04 – 18.05 mm (.710" – .7105") | 18.06 mm (.711) |
| Piston Pin | | |
| Models 290000 – 352000 | 17.07 – 17.08 mm (.6722" – .6725") | 17.06 mm (.6718") |
| Model 380000 | 18.00 – 18.01 mm (.7085" – .709") | 17.98 mm (.7078") |
| Piston Pin Bearing (Piston) | | |
| Models 290000 – 352000 | 17.09 – 17.1 mm (.6728" – .6735") | 17.12 mm (.674") |
| Model 380000 | 18.04 – 18.05 mm (.710" – .7105") | 18.06 mm (.711") |
| Piston Rings | | |
| Ring End Gap – Top, Center & Oil | 0.20 – 0.40 mm (.008" – .016") | 0.76 mm (.030") |
| Ring Side Clearance | | |
| Top & Center | 0.045 – 0.076 mm (.0018" – .003") | 0.10 mm (.004") |
| Oil | 0.11 – 0.15 mm (.0045" – .006") | 0.20 mm (.008") |

**SECTION REFERENCE
(By Subject)**

| | SECTION |
|--|----------------|
| Air Cleaner | 1 |
| Maintenance | |
| Air Guides | 5 |
| Installation | |
| Alternators | 7 |
| Identification | |
| Test Equipment | |
| Testing Output | |
| Troubleshooting | |
| Anti-Afterfire Solenoid | 3 |
| Armature | 2 |
| Air Gap | |
| Installation/Removal | |
| Testing | |
| (Also See <i>Check Ignition</i>) | 1 |
| Battery | 6 |
| Cables | |
| Charging | |
| Checking | |
| Recommendation | |
| (Also See <i>Checking Battery</i>) | 7C |
| Bearings | 10 |
| Checking | |
| Installation/Removal | |
| Breather | 8 |
| Checking | |
| Installation/Removal | |
| Cam Shaft | |
| Checking | 11 |
| Installation | 13 |
| Removal | 13 |
| Carburetor | 3 |
| Adjustment | |
| Anti-Afterfire System | |
| Assembly/Disassembly | |
| Remove | |
| Carburetor Controls | 4 |
| Charging System (See <i>Alternators</i>) | 7C |
| Coils (See <i>Armature</i>) | 2 |
| Compression Testing | 1 |
| Connecting Rod | |
| Checking | 12 |
| Installation | 13 |
| Crankcase Cover | |
| Checking | 10 |
| Installation | 13 |
| Crankshaft | |
| Checking | 11 |
| End Play | 13 |
| Installation/Removal | 13 |
| Cylinder Head | 5 |
| Cylinder | 10 |
| Bearings | |
| Resizing Bore | |
| Cylinder Balance Test | 1 |
| Cylinder Leakdown Test | 1 |
| Engine Identification System | 1 |
| Engine Specifications | Preface |
| Exhaust System – Supplied By Equipment Manufacturer | |
| Flywheel | 2 |
| Installation/Removal | |
| (Also See <i>Flywheel Identification</i>) | 7 |

**SECTION REFERENCE
(Continued)**

| | SECTION |
|---|----------------|
| Fuel Filter | 3 |
| Fuel Recommendations | 1 |
| Fuel Pump | 3 |
| General Information | 1 |
| Governor | 4 |
| Adjustment | |
| Governed Idle | |
| (Also See <i>Governed Idle Adjustment</i>) | 3, 13 |
| Ground Wire Harness | 2 |
| Ignition | 2 |
| Specifications | |
| (Also See <i>Check Ignition</i>) | 1 |
| Keyswitch – Testing | 2, 6 |
| Maintenance Schedule | 1 |
| Muffler – Supplied By Equipment Manufacturer | |
| Oil Drain | 1 |
| Oil Cooler | 8 |
| Oil Fill | 1, 8 |
| Oil Filter | 1 |
| Oil Pressure Switch | 8 |
| Oil Pump | 4, 8 |
| Oil Recommendations | 1, 8 |
| Oil Seal | 10 |
| Overhaul Procedure | 1 |
| Piston | 9 |
| Assembly | 12 |
| Checking | 12 |
| Removal | 9 |
| Piston Rings | 12 |
| Assembly/Removal | |
| Checking | |
| Pressure Lube | 8 |
| Regulator/Rectifier | 7 |
| Remote Controls | 4 |
| Adjustment | |
| Governed Idle | |
| Wire Travel | |
| Spark Plug | 1 |
| Specifications | 1 |
| Speed Control Adjustment | 4 |
| Starters, Electric | 6 |
| Assemble/Disassemble Starter | |
| Assemble/Disassemble Starter Drive | |
| Keyswitch – Testing | |
| Replace Brushes | |
| Test Equipment | |
| Testing | |
| Troubleshooting | |
| Stop Switch (See <i>Ground Wire Harness</i>) | 2 |
| Tools | 14 |
| Fastener And Torque Specifications | 1 |
| Troubleshooting | 1 |
| Tune-Up Procedure | 1 |
| Valves | 5 |
| Adjust Valve Clearances | |
| Refacing | |
| Seals | |
| Seats | |
| Valves – Installation/Removal | |

Section 1

GENERAL INFORMATION

| Section Contents | Page |
|--|-----------|
| IN THE INTEREST OF SAFETY | 2 |
| BRIGGS & STRATTON NUMERICAL IDENTIFICATION SYSTEM | 3 |
| MAINTENANCE | |
| Maintenance Schedule | 4 |
| Fuel And Oil Recommendations | 4 |
| Change Oil | 5 |
| Change Oil Filter | 5 |
| Clean Cooling System | 5 |
| Replace Spark Plugs | 5 |
| Air Cleaner Maintenance | 6 |
| Remove Combustion Chamber Deposits | 7 |
| TROUBLESHOOTING | |
| Systematic Check | 8 |
| Check Ignition (With Electric Starter) | 8 |
| Check Ignition (Engine Running) | 8 |
| Checking For Fouled Spark Plug | 8 |
| Check Carburetion | 9 |
| Check Compression | 9 |
| Cylinder Leakdown Test | 9 |
| Cylinder Balance Test | 9 |
| Equipment Affecting Engine Operation | 10 |
| TUNE-UP PROCEDURE | 11 |
| OVERHAUL PROCEDURE | 12 |

In the Interest of Safety



This safety alert symbol indicates that this message involves personal safety. Words danger, warning and caution indicate degree of hazard. Death, personal injury and/or property damage may occur unless instructions are followed carefully.



You are not ready to operate this engine if you have not read and understood the following safety items. Read this entire owner's manual and the operating instructions of the equipment this engine powers.

The Briggs & Stratton engine is made of the finest material in a state-of-the-art manufacturing facility. Please understand that Briggs & Stratton sells engines to original equipment manufacturers. It also sells to others in the distribution chain who may sell to the ultimate consumer, an equipment manufacturer, another distributor or a dealer. As a result, Briggs & Stratton does not necessarily know the application on which the engine will be placed. For that reason, carefully read and understand the operating instructions of the equipment before you repair or operate it.

You should also understand that there are equipment applications for which Briggs & Stratton does not approve the use of its engines. Briggs & Stratton engines are not to be used on vehicles with less than 4 wheels. They include motor bikes, aircraft products and All Terrain Vehicles. Moreover, Briggs & Stratton does not approve of its engines being used in competitive events. FOR THAT REASON, BRIGGS & STRATTON ENGINES ARE NOT AUTHORIZED FOR ANY OF THESE APPLICATIONS. Failure to follow this warning could result in death, serious injury (including paralysis) or property damage.



DO NOT run engine in an enclosed area. (Exhaust gases contain carbon monoxide, an odorless and deadly poison.)



DO NOT remove fuel tank cap nor fill fuel tank while engine is hot or running. **DO NOT** refuel indoors or in an unventilated area. (Allow engine to cool 2 minutes before refueling.)

DO NOT place hands or feet near moving or rotating parts.

DO NOT store, spill, or use gasoline near an open flame, nor near an appliance like a stove, furnace, or water heater that uses a pilot light or can create a spark.

DO NOT refuel indoors or in an unventilated area.

DO NOT operate or tip engine/equipment at such a severe angle that causes gasoline spillage.

DO NOT operate engine if gasoline is spilled or when smell of gasoline is present or other explosive conditions exist. (Move equipment away from spill and avoid any ignition until gasoline has evaporated.)

DO NOT transport engine with fuel in tank or fuel shut-off valve open.

DO NOT choke carburetor to stop engine, especially in an enclosed vehicle. (Whenever possible, gradually reduce engine speed before stopping.)

DO NOT tamper with governor springs, links or other parts to increase engine speed. (Run engine at speed set for equipment manufacturer.)

DO NOT check for spark with spark plug removed. (Use an approved tester.)

DO NOT run engine without blower housing or other safety shields removed when doing repairs.

DO NOT crank engine with spark plug removed. (If engine is flooded, place throttle in FAST and crank until engine starts.)

DO NOT strike flywheel with a hammer or hard object as this may cause flywheel to shatter in operation. (To remove flywheel, use Briggs & Stratton approved tools and procedures only.)

DO NOT operate engine without a muffler. (Inspect periodically and replace if worn or leaking. If engine is equipped with muffler deflector, inspect periodically and replace if necessary. Replacement parts must be same as on original equipment.)

DO NOT operate engine with an accumulation of grass, leaves or other combustible material in muffler area.

DO NOT use this engine on any forest covered, brush covered, or grass covered unimproved land unless a spark arrester is installed on muffler. The spark arrester must be maintained in working order by the owner and/or operator. In the State of California the above is required by law (Section 4442 of the California Public Resources Code). Other states may have similar laws. Federal laws apply on federal lands.

DO NOT touch hot muffler, cylinder, or fins which can cause burns.

DO NOT start engine with air cleaner or air cleaner cover removed (or cover over carburetor air intake, if Sno/Gard engine).

DO NOT attempt to start engine with cutting blade loose or removed. (Blade must be tight, otherwise a kickback may occur.)



- ✓ Prior to work, read and understand the section(s) of this manual that pertain to the job. Follow all safety warnings.
- ✓ PULL starter cord slowly until resistance is felt. Then pull cord rapidly to avoid kickback and prevent hand or arm injury.
- ✓ WEAR suitable eye protection (safety glasses, goggles or face shield when performing repair procedures).
- ✓ PREVENT ACCIDENTAL STARTING by removing spark plug wire from spark plug when servicing engine or equipment. Disconnect negative wire from battery terminal if equipped with electric starting system.
- ✓ REMOVE blower housing periodically and clean engine. Keep cylinder fins and governor parts free of dirt, grass and other debris which can affect engine speed.
- ✓ USE fresh gasoline. Stale fuel can gum carburetor and cause leakage.
- ✓ CHECK fuel lines and fittings frequently for cracks or leaks. Replace if necessary.
- ✓ USE ONLY Genuine Briggs & Stratton Parts or their equivalent. The use of replacement parts which are not of equivalent quality may damage the engine.



WARNING:



The engine exhaust from this product contains chemicals known to the State of California to cause cancer, birth defects, or other reproductive harm.

BRIGGS & STRATTON NUMERICAL NUMBER SYSTEM

All Briggs & Stratton engines have a unique numerical designation system. Each engine is identified by a Model, Type and Code number. Example:

| | | |
|--------|---------|----------|
| Model | Type | Code |
| 303447 | 0125 01 | 98052115 |

1

This chart explains the numerical model designation system. It is possible to determine most of the important mechanical features of the engine by merely knowing the model number. Here is how it works.

| | <u>FIRST DIGIT AFTER DISPLACEMENT</u> | <u>SECOND DIGIT AFTER DISPLACEMENT</u> | <u>THIRD DIGIT AFTER DISPLACEMENT</u> | <u>FOURTH DIGIT AFTER DISPLACEMENT</u> |
|------------------------------------|---|---|--|---|
| <u>CUBIC INCH DISPLACEMENT</u> | <u>BASIC DESIGN SERIES</u> | <u>CRANKSHAFT, CARBURETOR, GOVERNOR</u> | <u>PTO BEARING, REDUCTION GEAR, AUXILIARY DRIVE, LUBRICATION</u> | <u>TYPE OF STARTER</u> |
| 6 | 0 | 0 - Horizontal Shaft | 0 - Plain Bearing/DU Non-Flange Mount | 0 - Without Starter |
| 8 | 1 | Diaphragm Carburetor | | 1 - Rope Starter |
| 9 | 2 | Pneumatic Governor | 1 - Plain Bearing Flange Mounting | 2 - Rewind Starter |
| 10 | 3 | 1 - Horizontal Shaft | 2 - Sleeve Bearing Flange Mounting Splash Lube | 3 - Electric Starter Only 120 Volt Gear Drive |
| 11 | 4 | Vacu-Jet Carburetor | 3 - Ball Bearing Flange Mounting Splash Lube | 4 - Electric Starter/Generator 12 Volt Belt Drive |
| 12 | 5 | Pneumatic Governor | 4 - Ball Bearing Flange Mounting Pressure Lubrication on Horizontal Shaft | 5 - Electric Starter Only 12 Volt Gear Drive |
| 13 | 6 | 2 - Horizontal Shaft | 5 - Plain Bearing Gear Reduction (6 to 1) CW Rotation Flange Mounting | 6 - Alternator Only |
| 16 | 7 | Pulsa-Jet Carburetor | 6 - Plain Bearing Gear Reduction (6 to 1) CCW Rotation | 7 - Electric Starter 12 Volt Gear Drive With Alternator |
| 17 | 8 | Pneumatic or Mechanical Governor | 7 - Plain Bearing Pressure Lubrication on Vertical Shaft | 8 - Vertical Pull Starter or Side Pull Starter |
| 18 | 9 | 3 - Horizontal Shaft | 8 - Plain Bearing Auxiliary Drive (PTO) Perpendicular to Crankshaft | |
| 19 | A to Z | Flo-Jet Carburetor | 9 - Plain Bearing Auxiliary Drive Parallel to Crankshaft | |
| 22 | | Pneumatic Governor | | |
| 23 | | 4 - Horizontal Shaft | | |
| 24 | | Flo-Jet Carburetor | | |
| 25 | | Mechanical Governor | | |
| 26 | | 5 - Vertical Shaft | | |
| 28 | | Vacu-Jet Carburetor | | |
| 29 | | Pneumatic or Mechanical Governor | | |
| 30 | | 6 - Vertical Shaft | | |
| 31 | | 7 - Vertical Shaft | | |
| 32 | | Flo-Jet Carburetor | | |
| 35 | | Pneumatic or Mechanical Governor | | |
| 38 | | 8 - Vertical Shaft | | |
| 40 | | Flo-Jet Carburetor | | |
| 42 | | Mechanical Governor | | |
| 46 | | 9 - Vertical Shaft | | |
| | | Pulsa-Jet Carburetor | | |
| | | Pneumatic or Mechanical Governor | | |

The type number identifies certain unique features such as the crankshaft or governor spring used on an engine.

The code number identifies the assembly date of the engine. In some instances it is necessary to know the code number as well as the model and type number when performing adjustments, repairs or ordering replacement parts for an engine. Here is how it works.

Example: 98052115

- A. The first two digits, 98, indicate the calendar year, 1998.
- B. The second two digits, 05, indicate the calendar month, May.
- C. The third two digits, 21, indicate the calendar month day.
- D. The last two digits, 15, indicate the assembly line or manufacturing plant.

MAINTENANCE

| Maintenance Schedule | 5 Hours or Daily | 25 Hours or Every Season | 50 Hours or Every Season | 100 Hours or Every Season | 500 Hours |
|--|------------------|--------------------------|--------------------------|---------------------------|-----------|
| Check oil level ♦ | • | | | | |
| Change oil | | | • Note 1 | | |
| Change oil filter | | | | • Note 1 | |
| Change air cleaner pre-cleaner | | • Note 2 | | | |
| Change air cleaner cartridge | | | | • Note 2 | |
| Clean cooling system | | | | • Note 2 | |
| Inspect/clean spark arrester (optional accessory) | | | • | | |
| Replace or clean spark plugs | | | | • | |
| Replace in-line fuel filter | | | | • | |
| Clean combustion chamber deposits See Section 6 | | | | | • |

♦ Change oil after first 8 hours, then after every 50 hours or every season.

Note 1 Change oil every 25 hours when operating under heavy load or in high temperatures.

Note 2 Clean more often under dusty conditions or when airborne debris is present. Replace air cleaner parts, if very dirty.

Fuel And Oil Recommendations

Gasoline

We recommend the use of clean, fresh, lead-free gasoline, AND THE USE OF BRIGGS & STRATTON GASOLINE ADDITIVE, PART #5041. Leaded gasoline may be used if it is commercially available, and if lead-free is not available. A minimum of 85 octane is recommended. The use of lead-free gasoline results in fewer combustion deposits and longer valve life.

Note: Some fuels, called oxygenated or reformulated gasolines, are gasolines blended with alcohols or ethers. Excessive amounts of these blends can damage the fuel system or cause performance problems. Do not use gasoline which contains Methanol. If any undesirable operating symptoms occur, use gasoline with a lower percentage of alcohol or ether.

We also recommend gasoline be purchased in small quantities, not more than a 30 day supply. FRESH gasoline minimizes gum deposits, and also will ensure fuel volatility tailored for the season in which the engine will be operated.

Lubrication

Oil has four purposes. It cools, cleans, seals and lubricates. During normal operation, small particles of metal from the cylinder walls, pistons, bearings and combustion deposits will gradually contaminate the oil. Dust particles from the air also contaminate the oil

forming an abrasive mixture which can cause wear to all of the internal moving parts of the engine, if the oil is not changed regularly. Fresh oil also assists in cooling. Old oil gradually becomes thick and loses its cooling ability as well as its lubricating qualities.

Briggs & Stratton OHV V-Twin engines are lubricated with a gear-driven oil pump.

Oil Recommendations

We recommend the use of a high quality detergent oil classified "For Service SE, SF, or SG" such as Briggs & Stratton 30 weight oil part #100005 or #100028. Detergent oils keep the engine cleaner and retard the formation of gum and varnish deposits. No special additives should be used with recommended oils.

RECOMMENDED SAE VISCOSITY GRADES 4-Cycle Vanguard™ (Overhead Valve) Gasoline Engines

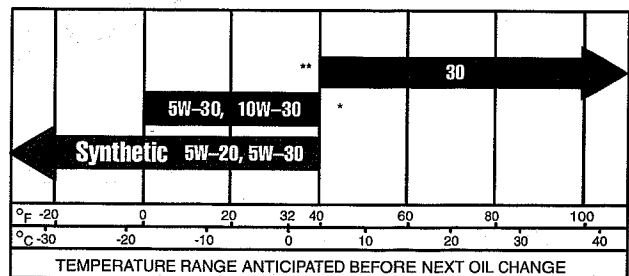

* Air cooled engines run hotter than automotive engines. Use of multi-viscosity oils (10W-30, etc.) above 4° C (40° F) will result in high oil consumption and possible engine damage. Check oil level more frequently if using these types of oils.

** SAE 30 oil, if used below 4° C (40° F), will result in hard starting and possible engine bore damage due to inadequate lubrication.

Change Oil

The crankcase capacity of Vanguard™ V-Twin cylinder engines is approximately:

1.65 liters (3-1/2 Pints) with filter

1.42 liters (3 Pints) without filter

IMPORTANT: DO NOT OVERFILL. Check and maintain oil level regularly. Change oil after first eight (8) hours of operation.

Thereafter, change oil every fifty (50) hours of operation. Change oil more often if engine is operated in dirty or dusty conditions or if engine is operated under heavy loads or in high ambient air temperatures.

Remove oil drain plug and drain oil while engine is still warm, Fig. 1 and Fig. 2. Replace drain plug.

Remove dipstick and refill slowly with new oil of proper service classification and viscosity grade. Refill to full mark on dipstick. When checking oil level, dipstick must be screwed all the way in for accurate readings. Start and run engine to check for oil leaks.

Change Oil Filter

Replace oil filter every 100 hours. Before installing new filter, lightly oil filter gasket with fresh clean engine oil. Screw filter on by hand until gasket contacts filter adapter. Tighten 1/2-3/4 turn farther, Fig. 1 and Fig. 2.

Start and run engine at idle for 30 seconds and stop engine. Recheck oil level and add if required. Restart engine and check for oil leaks.

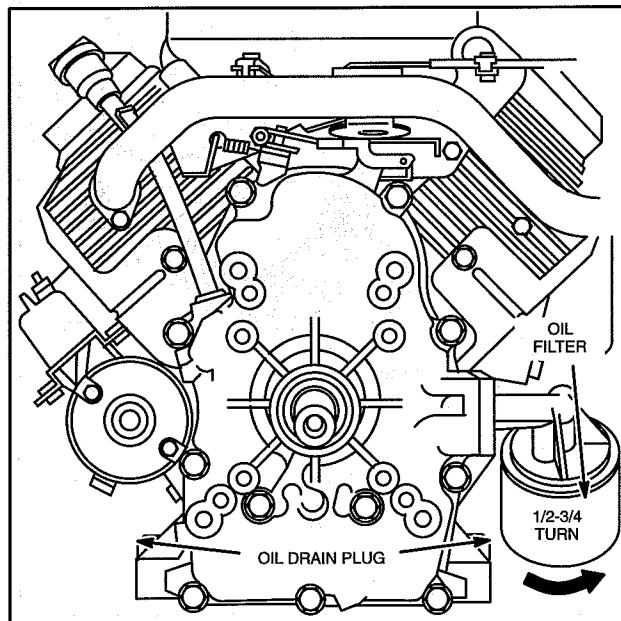

Fig. 1 – Horizontal Crankshaft Engine

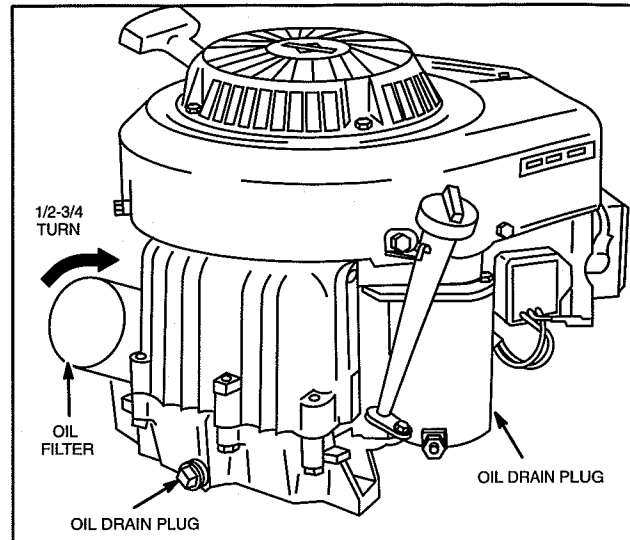

Fig. 2 – Vertical Crankshaft Engine

Clean Cooling System

Grass particles, chaff or dirt can clog the air cooling system, especially after prolonged service in cutting dry grass or very dirty air. Continued operation with a clogged cooling system can cause severe overheating and possible engine damage. Fig. 3 shows the blower housing removed and areas to be cleaned. This should be a regular maintenance operation, performed yearly or every 100 hours, whichever comes first.

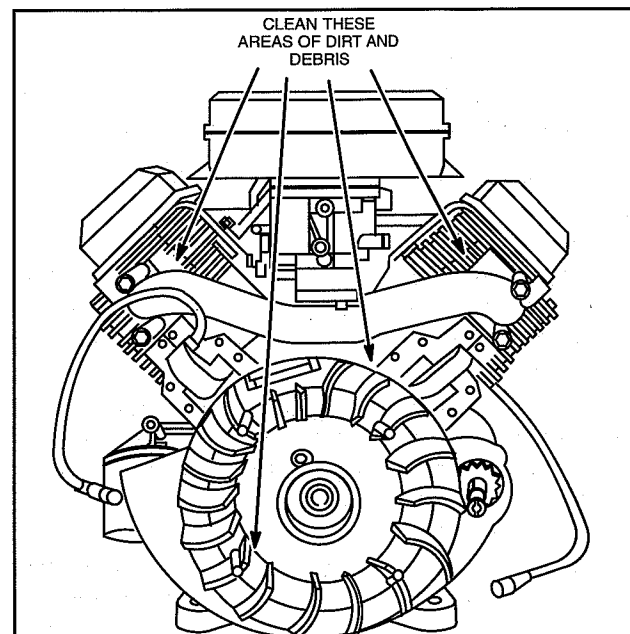

Fig. 3

Replace Spark Plugs

Replace spark plugs every 100 hours of operation or every season, whichever occurs first. Replace spark plugs if electrodes are burned away, or the porcelain is cracked. Set spark plug gap at .76 mm (.030") for all

models, Fig. 4. Torque spark plugs to 20.0 Nm (180 in. lbs.).

Spark plugs recommended by Briggs & Stratton for OHV Twin engines are:

| Spark Plug Type | Part No. | B&S Champion |
|-----------------|----------|--------------|
| Resistor Plug | 491055 | RC12YC |
| Resistor Plug | 496018 | RC14YC |

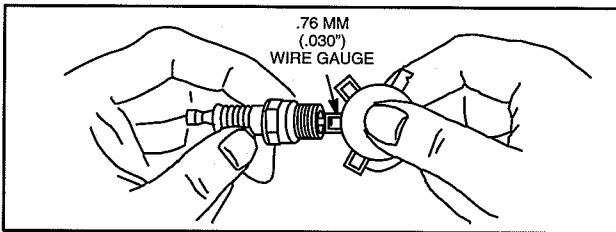

Fig. 4 – Checking Plug Gap

Note: DO NOT blast clean spark plugs. Spark plugs should be cleaned by scraping or hand wire brushing and washing in a commercial solvent.

Air Cleaner Maintenance

WARNING: NEVER OPERATE ENGINE WITH AIR CLEANER ASSEMBLY OR AIR CLEANER CARTRIDGE REMOVED. FIRE MAY RESULT.

A properly serviced air cleaner protects internal parts of the engine from dirt and dust particles in the air. If air cleaner instructions are not carefully followed, dirt and dust which should be collected in the cleaner, will be drawn into the engine. These particles are highly abrasive and will cause the piston rings and cylinder bore to wear quickly. As the rings and cylinder bore become worn, these abrasive particles enter the crankcase and contaminate the oil, forming an abrasive mixture which will cause wear on all of the internal moving parts.

The air cleaner on every engine brought in for a check up or repair should be examined and serviced. If the air cleaner shows signs of neglect, show it to the customer before cleaning. Instruct the customer on proper care, to assure long engine life.

Note: Replace air cleaner gaskets and mounting gaskets that are worn or damaged, to prevent dirt and dust entering engine due to improper sealing. Replace bent air cleaner mounting bracket.

Service Dual Element Air Cleaners

Remove and service foam pre-cleaner every 25 hours or every season, whichever occurs first, Fig. 5 or Fig. 6. Service cartridge every 100 hours or every season, whichever occurs first.

Note: Service air cleaner more often under dusty conditions.

To Service Pre-Cleaner – Round Dual Element

1. Remove cover assembly, Fig. 5 or Fig. 6.
 - a. Remove foam pre-cleaner from cartridge.
 - b. Wash it in liquid detergent and water.
 - c. Squeeze it dry in a clean cloth.
 - d. Saturate it in engine oil. Wrap it in clean absorbent cloth and squeeze to remove excess oil.
 - e. Reinstall pre-cleaner over cartridge.
 - f. Reinstall air cleaner cover.

To Service Cartridge – Round Dual Element

1. Remove knob and cover plate, Fig. 5 or Fig. 6.
 - a. Remove and inspect cartridge. Replace if damaged or dirty.

Note: DO NOT use petroleum solvents, such as kerosene, to clean paper cartridge. They may cause cartridge to deteriorate. DO NOT oil paper cartridge. DO NOT use pressurized air to clean or dry paper cartridge.

- a. Reinstall cartridge, cover plate, knob and pre-cleaner.

2. Reinstall air cleaner cover, Fig. 5 or Fig. 6.

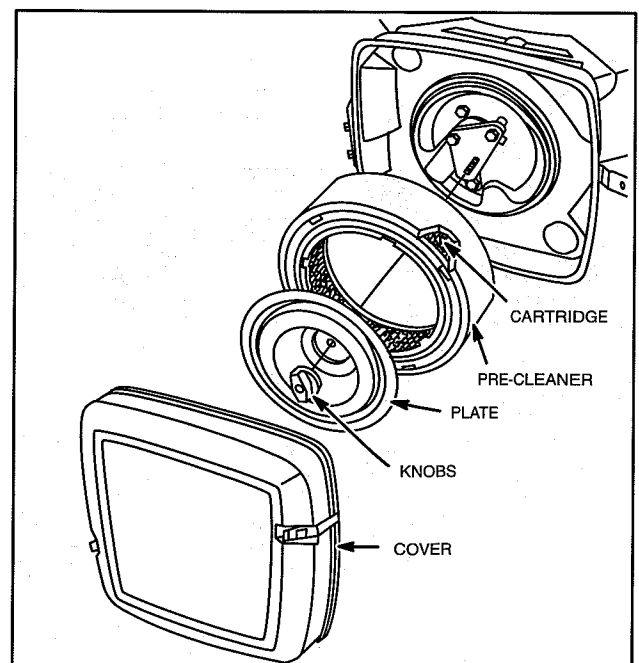

Fig. 5 – Round Dual Element Air Cleaner

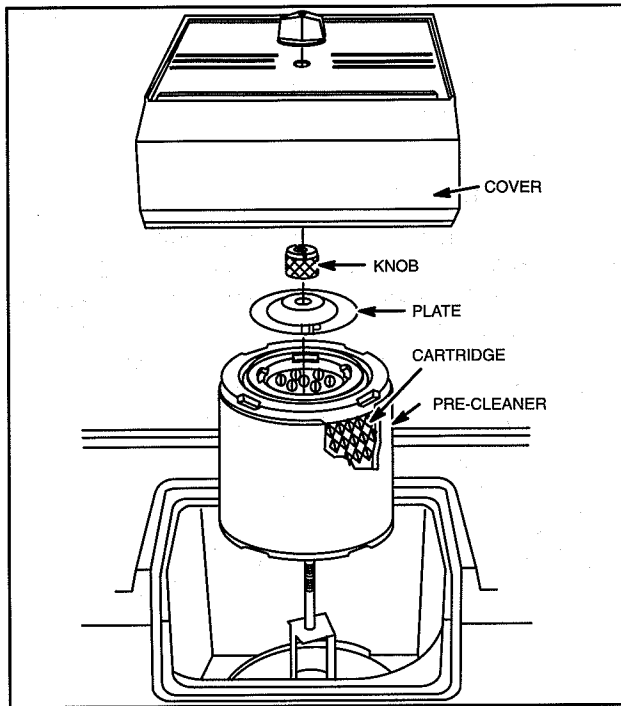

Fig. 6 – Round Dual Element Air Cleaner
(With Optional Fuel Tank)

To Service Pre-Cleaner – Square Dual Element

1. Remove cover assembly, Fig. 7.
 - a. Remove cartridge and pre-cleaner from cover.
 - b. Wash pre-cleaner in liquid detergent and water.
 - c. Squeeze it dry in a clean cloth.
 - d. Saturate it in engine oil. Wrap it in clean absorbent cloth and squeeze to remove excess oil.
 - e. Install pre-cleaner in cover with foam toward cover. (Nylon screen toward paper element.)
 - f. Install paper cartridge in cover with tabs on cartridge in slots of cover, Fig. 7.
 - g. Reinstall cover assembly on air cleaner body.

To Service Cartridge – Square Dual Element

1. Remove cover assembly, Fig. 7.
 - a. Remove and inspect cartridge. Replace if damaged or dirty.

Note: **DO NOT** use petroleum solvents, such as kerosene, to clean paper cartridge. They may cause cartridge to deteriorate. **DO NOT** oil paper cartridge. **DO NOT** use pressurized air to clean or dry paper cartridge.

 - b. Reinstall paper cartridge in cover with tabs on cartridge in slots on cover, Fig. 7.
 - c. Reinstall cover assembly on air cleaner body.

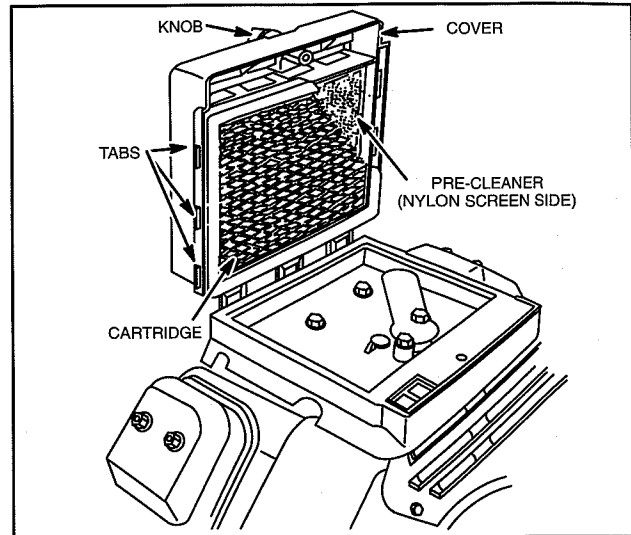

Fig. 7 – Square Dual Element Air Cleaner

Remove Combustion Chamber Deposits

Combustion chamber deposits should be removed every 500 hours or whenever cylinder heads are removed. See Section 2 for removal procedure.

Remove combustion chamber deposits from combustion chamber and around valves using a soft, hand wire brush or scraper. With piston at Top Dead Center, remove combustion chamber deposits from top of piston. Use care to prevent combustion chamber deposits from entering push rod or oil return cavity in cylinder.

Take care not to damage cylinder, top of piston, cylinder head and cylinder head gasket surfaces.

Note: Remove only the combustion chamber deposits. It is not necessary to remove the discoloration marks on the piston, valves and cylinder head. These marks are normal and will not affect engine operation.

Remove the loose deposits from around the top ring land area using compressed air or a soft bristle brush.



WARNING: TO PREVENT EYE INJURY ALWAYS WEAR EYE PROTECTION WHEN USING COMPRESSED AIR.

Troubleshooting

Most complaints concerning engine operation can be classified as one or a combination of the following:

1. Will not start
2. Hard starting
3. Lack of power
4. Runs rough
5. Vibration
6. Overheating
7. High oil consumption

Note: **What appears** to be an engine malfunction may be a fault of the powered equipment rather than the engine. If equipment

is suspect, see Equipment Affecting Engine Operation.

Systematic Check

If the engine will not start and the cause of malfunction is not readily apparent, perform a systematic check in the following order:

1. Ignition
2. Carburetion
3. Compression

This check-up, performed in a systematic manner, can usually be done in a matter of minutes. It is the quickest and surest method of determining the cause of failure. The basic check-up procedure is the same for all engine models, while any variation, by model, will be shown under the subject heading.

Check Ignition (With Engine Starter)

Note: Magnetron® ignition system requires a minimum of 350 RPM to produce spark.

With spark plugs installed, attach a #19368 ignition tester to each spark plug lead and ground the other end of the tester as shown in Fig. 8. Spin the flywheel rapidly with engine starter. If spark jumps the tester gaps, you may assume the ignition system is functioning satisfactorily.

! WARNING: ON MAGNETRON® EQUIPPED ENGINES, SPARK CAN STILL OCCUR WITH A SHEARED FLYWHEEL KEY. A SEVERE SHOCK OR KICKBACK HAZARD MAY EXIST.

Note: Engines equipped with Magnetron® ignition system will still display spark at tester with a partially or fully sheared flywheel key. A partially sheared flywheel key will affect ignition timing and engine performance.

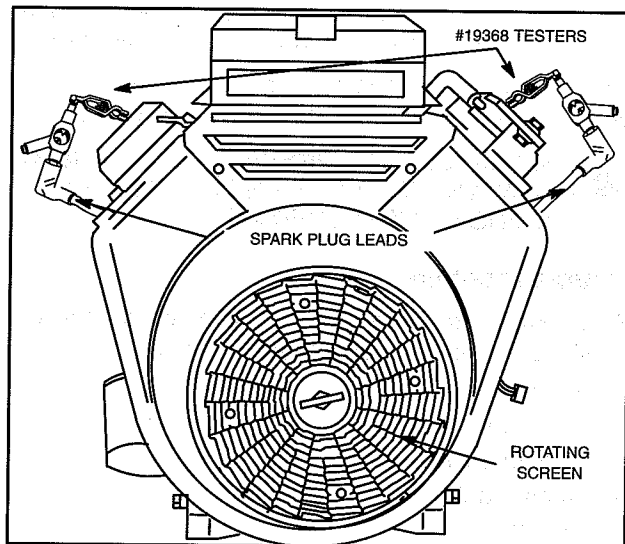

Fig. 8 – Checking For Spark

If spark does not occur look for –

1. Improperly operating interlock system
2. Shorted equipment stop switch wire

3. Two closed diodes in ground wire harness (current style) or ground terminal (early style)
4. Incorrect armature air gap
5. Armature failure

Check Ignition (Engine Running)

If engine runs but misses during operation, a quick check to determine if ignition is or is not at fault can be made by installing Tool #19368 tester between the spark plug lead and each spark plug, Fig. 9. A spark miss will be readily apparent when the engine is running. If spark is good but engine misses, check for a fouled spark plug.

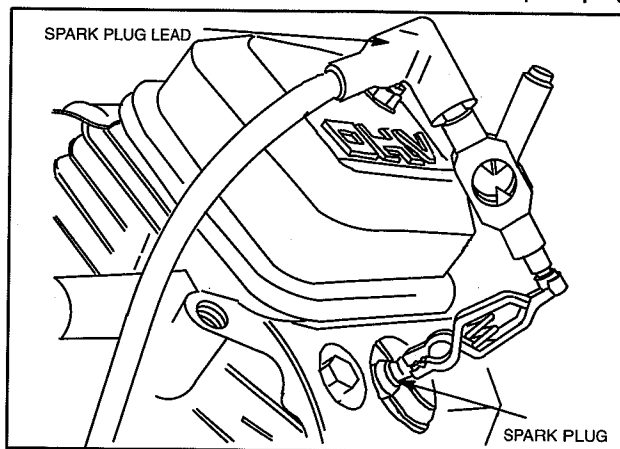

Fig. 9 – Running Check

Check Ignition (Fouled Plug or Other Causes)

To check for a fouled spark plug or a non-functioning cylinder, attach Tool #19368 tester between the spark plug lead and each spark plug. With engine running at top no load speed, ground one spark plug, Fig. 10. The engine should continue to run on the other cylinder. Repeat this test with the other cylinder. If the engine will not continue to run when making this test, the cylinder that is NOT grounded is not functioning and/or the spark plug is fouled. Install a new spark plug before proceeding. If miss continues, problem may be carburetion or compression. See Check Carburetion, Check Compression. Also see Cylinder Balance Test.

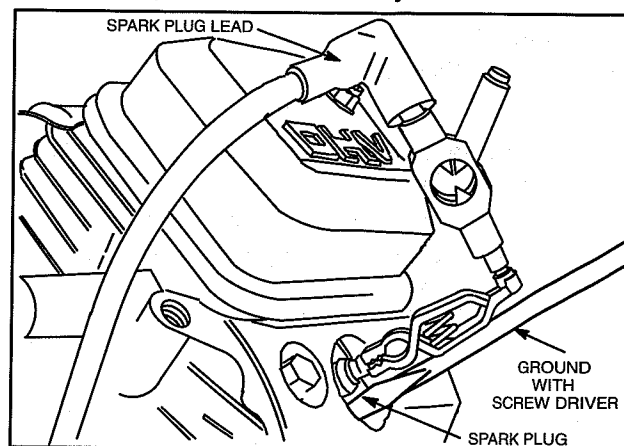

Fig. 10 – Checking For Fouled Plugs

Check Carburetion

Before making a carburetion check, be sure the fuel tank has an ample supply of fresh, clean gasoline. Be sure that the shutoff valve, if equipped, is open and fuel flows freely through the fuel line before starting engine. Inspect and adjust the idle needle valve. Check to see that the choke closes completely. If engine will not start, remove and inspect the spark plugs.

If plugs are wet, look for –

1. Overchoking
2. Excessively rich fuel mixture
3. Water in fuel
4. Float needle valve stuck open
5. Plugged air cleaner

If plug is dry, look for –

1. Leaking carburetor mounting gaskets
2. Gummy or dirty carburetor, fuel line or tank
3. Float needle valve stuck shut
4. Inoperative fuel pump
5. Inoperative anti-afterfire solenoid

A simple check to determine if the fuel is getting to the combustion chamber through the carburetor is to remove either spark plug and pour a small quantity of gasoline through the spark plug hole. Replace the plug. If the engine fires a few times and then stops, look for the same conditions as for a dry plug.

Check Compression

Briggs & Stratton does not publish any compression pressures, as it is extremely difficult to obtain an accurate reading without special equipment. It has been determined through testing, a simple and accurate indication of compression can be made as follows:

Remove both spark plugs and insert a compression gauge into either cylinder (one cylinder at a time). Turn engine over with engine starter until there is no further increase in pressure. Record this reading. Repeat procedure on other cylinder and record that reading. The difference between both cylinders should not exceed 25%. More than 25% indicates loss of compression in the cylinder with lower pressure. See example.

Example:

| | Cyl. #1 | Cyl. #2 | Diff. | % Diff. |
|---------|---------|---------|--------|---------|
| Eng. #1 | 65 PSI | 60 PSI | 5 PSI | 7.6% |
| Eng. #2 | 75 PSI | 55 PSI | 20 PSI | 26.7% |

If compression is poor, look for –

1. Loose cylinder head bolts
2. Blown head gasket
3. Burned valves, valve seats and/or loose valve seats
4. Insufficient tappet clearance
5. Warped cylinder head
6. Warped valve stems

7. Worn bore and/or rings
8. Broken connecting rods

Cylinder Leakdown Test

The cylinder leakdown tester, Tool # 19413, may be used to test the sealing capability of the compression components of each cylinder and quickly identify the problem component.

Cylinder Balance Test

If the engine is hard starting, runs rough, misses or lacks power, perform a cylinder balance test to determine whether both cylinders are operating to their full potential.

Tools Required

1. Tachometer, Tool #19200
2. Two #19368 Ignition Testers
3. Screwdriver with insulated handle

Attach ignition tester, Tool #19368 between the spark plug lead and each spark plug, Fig. 11.

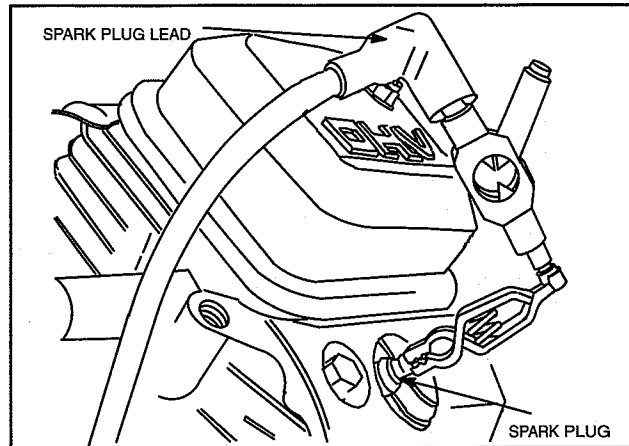

Fig. 11

Start and run engine running at top no load speed and note spark at ignition testers. If the spark is equal at both ignition testers, the problem is not ignition related. A spark miss will be readily apparent. Now note RPM of engine. Ground out one cylinder with screwdriver by contacting alligator clip on ignition tester and a good ground on engine, Fig. 12. Note RPM loss. Then ground out the other spark plug and note the RPM loss. If the difference between the two cylinders does not exceed 75 RPM, the amount of work the two cylinders are doing should be considered equal.

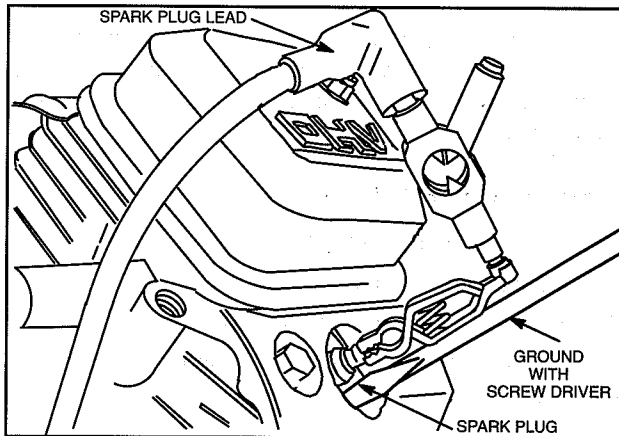

Fig. 12 – Cylinder Balance Test

Things Which Affect Both Cylinders

1. Carburetion
2. Crankcase vacuum
3. Ignition timing
 - a. A partially sheared flywheel key will effect ignition timing and engine performance.

If the RPM loss is greater than 75 RPM this indicates that the cylinder with the least RPM loss is the weakest of the two cylinders. Look to that cylinder for a problem. See Example.

Example:

Engine RPM – Both Cylinders = 3400 RPM

Engine RPM – #1 Cylinder Grounded = 3300 RPM

Engine RPM – #2 Cylinder Grounded = 3100 RPM

Conclusion: #1 cylinder is weakest of the two cylinders.

Things Which Affect One Cylinder

1. Spark plug
 - a. A fouled spark plug may indicate that carburetor is out of adjustment.
2. Leak in spark plug wire
3. Head gasket
4. Intake manifold
 - a. A leak at either end of the intake manifold will only affect one cylinder, not both.
5. Valves
6. Rings
7. Piston
8. Cylinder

The cylinder balance test will also detect a cylinder that is not functioning. When grounding out one cylinder there will be no RPM loss. When the other cylinder is grounded out the engine will stop.

Note: A twin cylinder engine will run well on one cylinder as long as the power required for the application does not exceed the power produced by the one cylinder.

Equipment Affecting Engine Operation

Frequently, what appears to be a problem with engine operation, such as hard starting, vibration, etc., may be the fault of the equipment powered rather than the engine itself. Since many varied types of equipment are powered by Briggs & Stratton engines, it is not possible to list all of the various conditions that may exist. Listed are the most common effects of equipment problems, and what to look for as the most common cause.

Hard Starting or Will Not Start

1. Loose belt – a loose belt like a loose blade can cause a backlash effect, which will counteract engine cranking effort.
2. Starting under load – see if the unit is disengaged when engine is started; or if engaged, should not have a heavy starting load.
3. Check remote control assembly for proper adjustment.
4. Check interlock system for shorted wires, loose or corroded connections, or defective modules or switches.

Engine Won't Stop

1. Check equipment ignition stop switch.
2. Check for loose or disconnected equipment stop switch wire.
3. Check ground wire harness (current style) or ground terminal (early style) on engine.
 - a. See Section 2 for test procedure.

Vibration

1. Cutter blade bent or out of balance – remove and balance.
2. Mounting bolts loose – tighten.

Power Loss

1. Bind or drag in unit – if possible, disengage engine and operate unit manually to feel for any binding action.
2. Grass cuttings build-up under deck.
3. No lubrication in transmission or gear box.
4. Excessive drive belt tension may cause seizure.

Noise

1. Cutter blade coupling or pulley – an oversize or worn coupling can result in knocking, usually under acceleration. Check for fit or tightness.
2. No lubricant in transmission or gear box.

TUNE-UP PROCEDURE

A "Tune-Up," see the steps listed below, would normally be performed on relatively new engines brought in for minor difficulties. By performing these steps you will either be sure that the engine is functioning properly or will know what major repairs should be made. The steps are also covered in the Overhaul Procedure and will normally be performed as a part of the complete overhaul.

STEP NO.

| | |
|-----|--|
| 1. | Remove and ground spark plug wires. |
| 2. | Remove air cleaner cartridge, check for proper servicing. Check gaskets, pre-cleaner and cartridge for damage. |
| 3. | Check oil level and drain oil. Remove oil filter. |
| 4. | Remove blower housing, inspect rewind assembly, when so equipped. |
| 5. | Clean cooling fins and entire engine. |
| 6. | Check governor, linkage and springs for damage, wear, also check adjustment. |
| 7. | Remove intake manifold and carburetor, disassemble carburetor and inspect for wear or damage. Wash in solvent. Replace gaskets and parts as necessary. Reinstall carburetor on manifold. Set initial adjustment. |
| 8. | Remove spark plugs and clean or replace. Remove flywheel. Check flywheel key. Check for oil seal leakage, both flywheel and PTO sides. |
| 9. | Check coils. Inspect all wires for breaks and/or damaged insulation. Be sure ground wires do not touch flywheel. Check ground wire and stop switch connection. |
| 10. | Install flywheel and set air gap. Check for spark with tool #19368, tester. |
| 11. | Remove cylinder heads. Remove carbon. Check gaskets. Inspect valves for seating |
| 12. | Reinstall cylinder heads using new gaskets. Tighten to specified torque. Adjust valve clearance. Set spark plug gaps. |
| 13. | Reinstall intake manifold using new gaskets. |
| 14. | Reinstall blower housing. |
| 15. | Install new oil filter. Replace oil and fuel. |
| 16. | Adjust equipment control and cables, if used, for correct operation. |
| 17. | Service air cleaner pre-cleaner and cartridge, or replace. |
| 18. | Check muffler for restrictions or damage. |
| 19. | Start engine and bring up to operating temperature. Then, adjust carburetor mixture and engine top speed. |

OVERHAUL PROCEDURE

The Overhaul Procedure which follows is intended to help you to become accustomed to a systematic method of repairing Briggs & Stratton OHV engines. Naturally these steps could be rearranged in different order but efficiency is obtained when the repair operations are performed in the same sequence every time. The exact procedure will vary according to the engine model being repaired.

The Overhaul Procedure can also be used as an index. For information on how to perform most operations listed, refer to the section number shown. Be careful to locate the instructions covering the specific model being repaired.

SEC. DISASSEMBLE

| | |
|----|---|
| 8 | Drain oil – Remove oil filter |
| 1 | Spark plugs. Clean or replace |
| 3 | Air cleaner assembly Fuel tank and bracket assembly (if equipped) Fuel pump and bracket (if equipped) |
| 2 | Rotating screen (if equipped) Blower housing |
| 7 | Rewind starter (if equipped) |
| 12 | Exhaust manifold, muffler(s) |
| 3 | Intake manifold and carburetor |
| 3 | Check throttle shaft and bushings for wear |
| 3 | Disassemble carburetor |
| 2 | Check armature air gap, Remove armatures |
| 2 | Flywheel |
| 7 | Electric starter |
| 8 | Breather |
| 5 | Governor control bracket |
| 6 | Check valve clearances |
| 6 | Cylinder shields Rocker arms. Push rods. Cylinder heads |
| 6 | Valves, springs and seals Inspect and check guides and seats |
| 10 | Check crankshaft end play Remove burrs from crankshaft extension |
| 10 | Crankcase cover – Inspect and check bearings, Remove oil seal |
| 10 | Cam gear and tappets – Inspect governor |
| 9 | Connecting rods and pistons |
| 10 | Crankshaft – Inspect and check |
| 11 | Cylinder – check cylinder bores and bearings, Remove oil seal |
| 9 | Disassemble and check connecting rods, pistons, piston pins and rings |
| 8 | Disassemble and check oil pump |

SEC. REPAIRS

| | |
|----|---|
| | Clean parts |
| 11 | Resize cylinder bore to next oversize |
| 11 | Replace main bearing |
| 11 | Replace all oil seals |
| 6 | Replace valve guides – intake or exhaust |
| 6 | Reface valves and seats and lap |
| 2 | Replace armatures |
| 3 | Repair carburetor |
| 7 | Replace rewind starter spring and rope (if so equipped) |

SEC. REASSEMBLE

| | |
|----|---|
| 10 | Crankshaft |
| 9 | Pistons, piston pins, rings and connecting rods |
| 10 | Tappets, cam gear |
| 5 | Mechanical governor |
| 8 | Oil pump |
| 10 | Crankcase cover – check end play |
| 7B | Electric starter (12 V) |
| 2 | Flywheel and starter pulley (if equipped) |
| 2 | Armatures – adjust air gap |
| 1 | Check spark |
| 6 | Valves, seals, springs and retainers |
| 6 | Cylinder heads, push rods, rocker arms and cylinder shields |
| 6 | Adjust valve clearance |
| 8 | Valve covers, breather and valley cover |
| 4 | Linkage and governor controls |
| 3 | Carburetor and intake manifold |
| 5 | Check and adjust mechanical governor |
| 2 | Blower housing |
| 3 | Fuel pump and bracket (if equipped), fuel tank and bracket (if equipped) |
| 3 | Clean and assemble air cleaner |
| 12 | Exhaust manifold, mufflers |
| 1 | Spark plugs |
| 1 | Fill crankcase with oil, Fill with gas Start engine |
| 3 | Adjust carburetor |
| 5 | Adjust governor controls to obtain correct engine speed (remote controls) |
| 6 | Retorque cylinder head screws |
| | Spray paint engine and apply decals |

Section 2 IGNITION

| Section Contents | Page |
|--|------|
| SPECIFICATIONS | 1 |
| GENERAL INFORMATION | 1 |
| ARMATURES | |
| Testing | 1 |
| Remove Armature | 2 |
| Install Armatures | 2 |
| Adjust Armature Air Gap | 2 |
| FLYWHEEL | |
| Remove Flywheel Nut Engine Models 290000-303000 | 2 |
| Remove Flywheel Nut Engine Models 350000-380000 | 3 |
| Remove Flywheel – All Models | 3 |
| Inspect Flywheel Key and Keyways | 3 |
| Install Flywheel | 3 |
| Torque Flywheel Nut Engine Models 290000-303000 | 3 |
| Torque Flywheel Nut Engine Models 350000-380000 | 4 |
| Remove And Install Fan Engine Models 350000-380000 | 4 |
| GROUND WIRE HARNESS AND GROUND TERMINAL | |
| Testing Ground Wire Harness And Ground Terminal | 5 |
| Testing Rocker Stop Switch | 6 |
| Testing Rotary Key Switch | 7 |

SPECIFICATIONS FOR ALL V-TWIN CYLINDER ENGINE MODELS

| Basic Model Series | Armature Air Gap | Flywheel Puller Part No. | Flywheel Nut Torque | |
|--------------------|-----------------------------------|--------------------------|---------------------|-------|
| | | | Ft. Lbs. | Nm |
| 290000 – 380000 | .008" to .012" (.20 to .30 mm) | 19203 | 125 | 170.0 |

See Section 1 For Spark Plug Maintenance And Specifications

General Information

Briggs & Stratton OHV V-Twin engines use MAGNETRON® ignition: an ignition armature with a self-contained transistor module (no moving parts). Two MAGNETRON® ignition armatures are used, with a flywheel containing a permanent magnet.

Note: Magnetron® ignition system requires a minimum of 350 RPM to produce spark.

Armature Testing

The condition of the ignition armatures can be accurately diagnosed using ignition tester, Tool #19368 as described in "Troubleshooting" in Section 1.

Removing Armatures

1. Remove rotating screen and blower housing, Fig. 1.
2. Remove armature screws and lift off armatures.
 - a. Disconnect stop switch wires at armatures.

Note: The flywheel does not need to be removed except check the keyways and flywheel key.

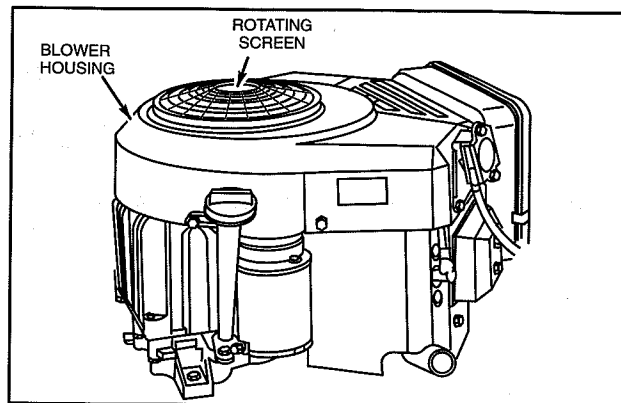

Fig. 1 - Remove Armature

Install Armatures

1. Turn flywheel so magnet is away from armature.
2. Install ground wire onto tab terminal on armature.
Note: Make sure wires are routed over armature mounting posts and away from flywheel.

3. Assemble armature to engine, Fig. 2.
 - a. Mounting holes in armature are slotted. Push armature away from flywheel as far as possible and tighten one screw to hold armature in place.
4. Repeat for second armature.

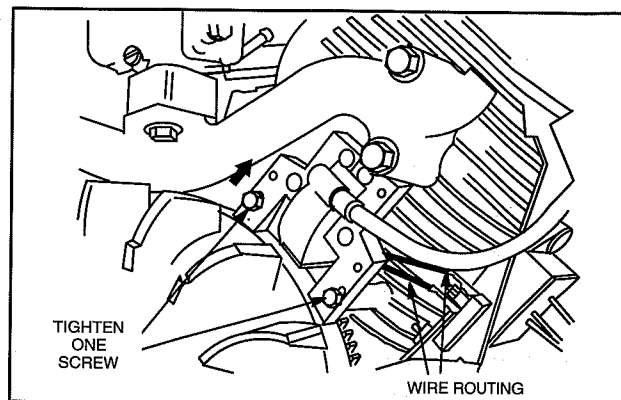

Fig. 2 - Install Armature

Adjust Armature Air Gap

1. Rotate flywheel until magnet is under armature laminations.
2. Place thickness gauge, .008"-.012" (0.20-.30 mm) between magnet and armature laminations, Fig. 3.
3. Loosen mounting screw so magnet will pull armature down against thickness gauge.
 - a. Torque screws to 25 in. lbs. (3.0 Nm).
4. Rotate flywheel to remove thickness gauge.
5. Repeat for second armature.

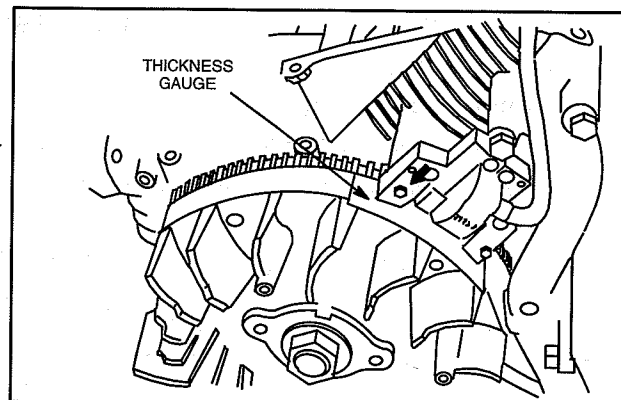

Fig. 3 - Adjust Air Gap

FLYWHEEL

Remove Flywheel Nut -

Engine Models 290000-303000

1. Place flywheel strap wrench, Tool #19433 around outer rim of flywheel, Fig. 4.
2. Remove flywheel nut using 30 mm socket.

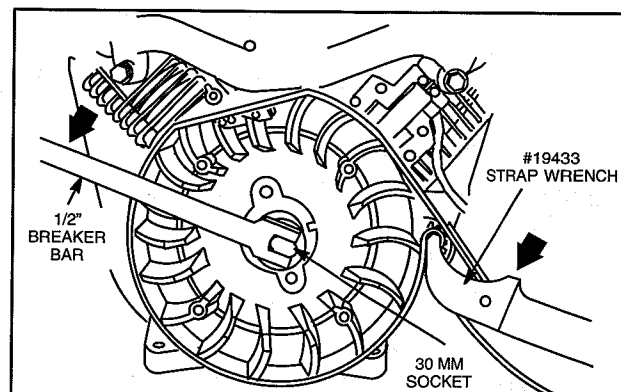

Fig. 4 - Remove Flywheel Nut Models 290000 & 303000

Remove Flywheel Nut – Engine Models 350000-380000

1. Place flywheel holder, Tool #19321 on fan retainer with lugs of flywheel holder engaging slots on the fan retainer, Fig. 5.

Note: If engine is equipped with rewind starter hub remove starter hub screw first. Then remove flywheel nut.

2. Remove flywheel nut and washer.

Note: Do not remove fan retainer and fan.

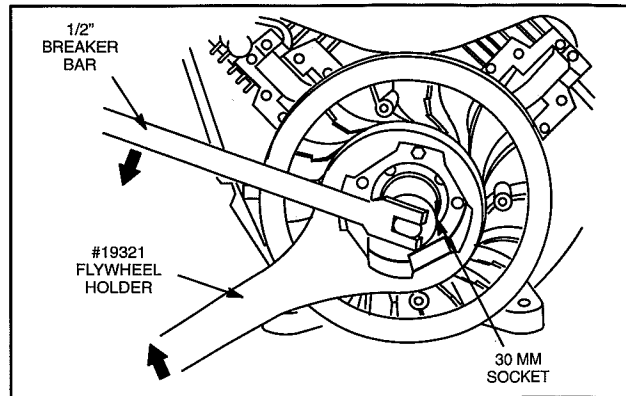

Fig. 5 – Remove Flywheel Nut Models 350000 & 380000

Remove Flywheel – All Models

1. Reinstall flywheel nut. Turn nut down flush with top of threads.
2. Install flywheel puller, Tool #19203.
3. Tighten puller screws equally until flywheel loosens, Fig. 6.



DO NOT STRIKE FLYWHEEL WITH A HARD OBJECT OR A METAL TOOL AS THIS MAY CAUSE FLYWHEEL TO SHATTER IN OPERATION. ALWAYS USE APPROVED FLYWHEEL REMOVAL TOOLS.

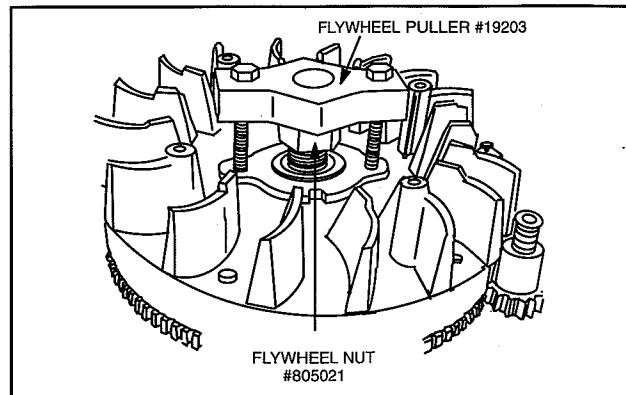

Fig. 6 – Remove Flywheel

Inspect Flywheel Key, Keyways, Flywheel and Crankshaft

Check flywheel key for damage. Check flywheel for cracks, broken fins or keyway damage. Also check crankshaft keyways and taper for damage. Replace crankshaft, if damaged.

Install Flywheel – All Models



CLEAN FLYWHEEL AND CRANKSHAFT TAPER REMOVING ALL OIL, DIRT OR GREASE.

1. Assemble flywheel to crankshaft and align keyways.
2. Insert flywheel key into crankshaft.

Torque Flywheel Nut – Engine Models 290000-303000

1. Install starter hub (if equipped), washer and flywheel nut.
2. Place flywheel strap wrench, Tool #19433 around outer rim of flywheel, Fig. 7.
3. Torque flywheel nut to 175.0 Nm (125 ft. lbs.).

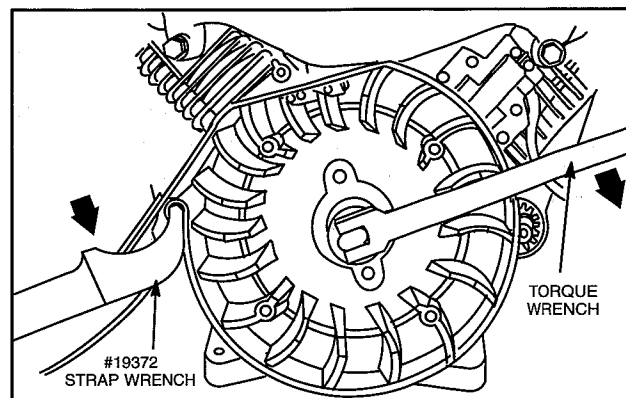

Fig. 7 – Torque Flywheel Nut

Torque Flywheel Nut – Engine Models 350000-380000

1. Install washer and flywheel nut.
2. Assemble flywheel holder, Tool #19321 to retainer.
3. Torque flywheel nut to 175.0 Nm (125 ft. lbs.), Fig. 8.
 - a. Install starter hub and screw (if equipped) and torque to 48.0 Nm (35 ft. lbs.).

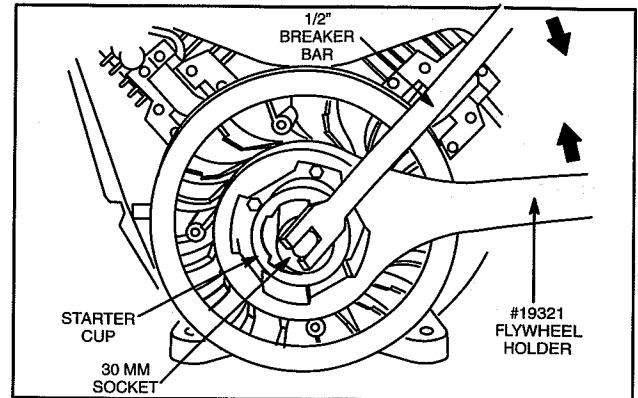

Fig. 8 – Torque Flywheel Nut

Remove/Install Fan – Engine Models 350000-380000

Remove:

If engine is equipped with rewind starter hub, remove starter hub screw first.

1. Remove two screws, fan retainer and fan.

Install:

1. Align boss on back of fan with notch in flywheel.
2. Align cut out in retainer with cut out in fan.
3. Torque screws to 17.0 Nm (150 in. lbs).

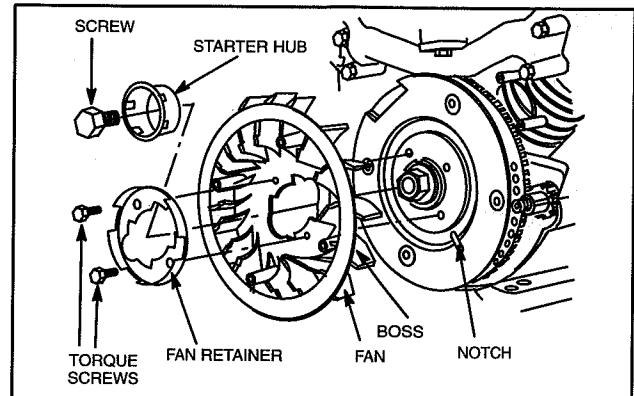

Fig. 9 – Remove/Install Fan

GROUND WIRE HARNESS AND GROUND TERMINAL

Two different style ground wires and ground terminals are used.

Current Style

The current style system uses a ground wire harness, containing diodes, with an insulated stop terminal mounted on the #1 cylinder shield. The ground wire harness has a lead and brass colored spade terminal for each armature and a right angled ground spade terminal, Fig. 10. The right angle ground spade terminal attaches to the insulated stop terminal.

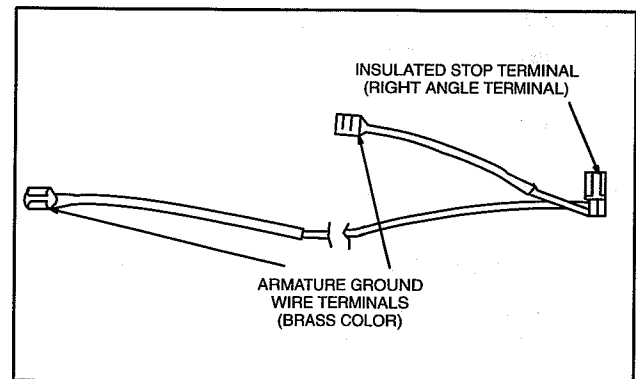

Fig. 10 – Ground Wire Harness – Current Style

The ground wire harness used with the rocker stop switch has two ground spade terminals: a right angle ground spade terminal that attaches to the insulated stop terminal and a large insulated spade terminal, Fig. 11. The larger insulated spade terminal attaches to the rocker stop switch.

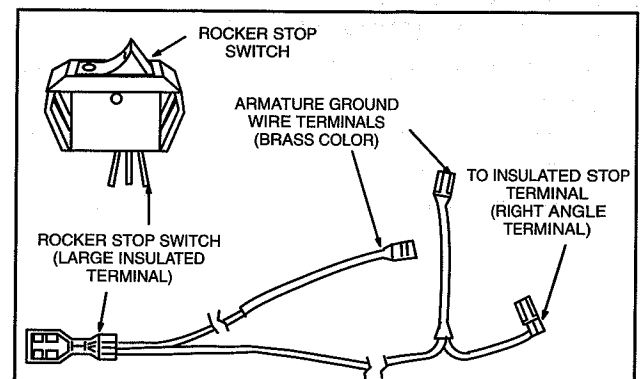

Fig. 11 – Ground Wire Harness –
Used With Rocker Stop Switch

Early Style

The early style system consists of a ground terminal, containing diodes. The ground terminal has a tab terminal for each armature ground wire, and a tab terminal for the equipment stop switch wire Fig. 12. The ground terminal is located on the #1 cylinder shield near the starter motor.

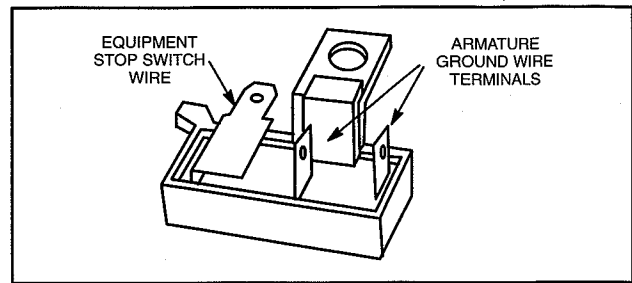

Fig. 12 – Ground Terminal – Early Style

Troubleshooting

The ground wire harness (current style) and ground terminal (early style) contain two diodes. If a diode fails “open,” the cylinder with the open diode will continue to run when the equipment key switch is turned off. If a diode fails “short,” the cylinder with the shorted diode will not run (no spark). Fig. 13.

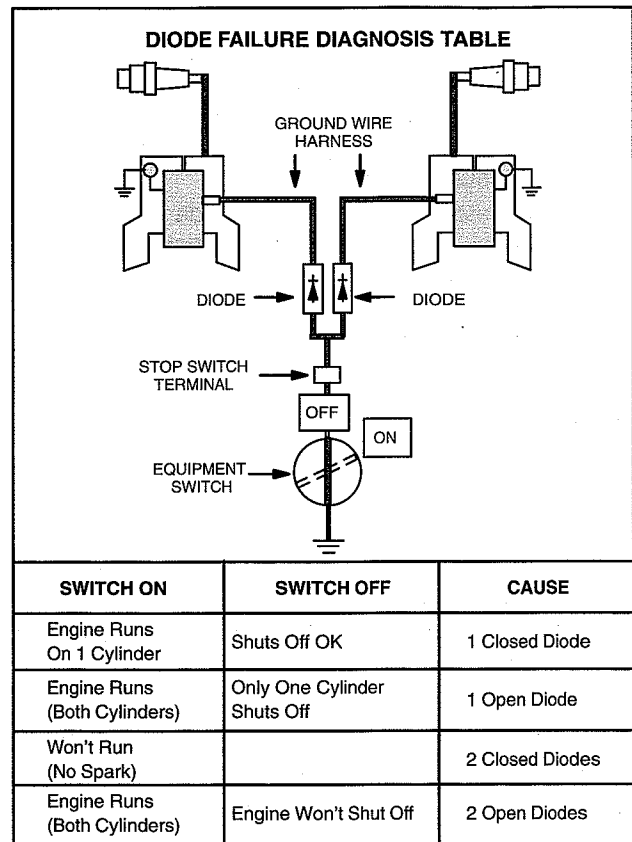

Fig. 13

Testing Ground Wire Harness And Ground Terminal

The Digital Multimeter, Tool #19390 is recommended to test the ground wires, Fig. 14. The digital multimeter is available from your Briggs & Stratton source of supply.

The following test will be made with the meter in the “Diode Test Position” .

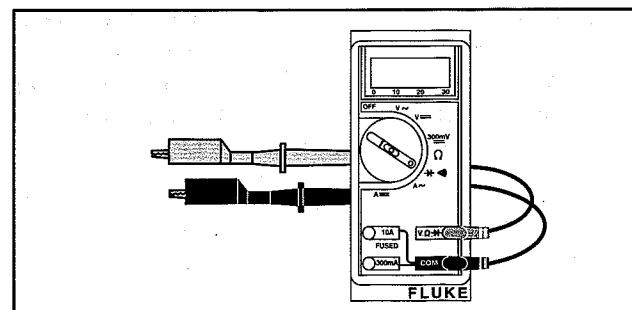

Fig. 14 – Digital Multimeter – Tool #19390

In the Diode Test position, the meter will display the forward voltage drop across the diode(s). If the voltage drop is less than 0.7 volts, the meter will “Beep” once as well as display the voltage drop. A continuous tone indicates continuity (shorted diode) An incomplete circuit (open diode) will be displayed as “OL.”

1. Insert RED test lead into $V \Omega \rightarrow$ receptacle in meter.
2. Insert BLACK test lead into **COM** receptacle in meter.
3. Rotate selector to \rightarrow (Diode Test) position.
4. Attach RED test lead clip to terminal "A" (stop switch wire terminal), Fig. 15, current style or early style. Leave attached for remainder of test.
5. Touch BLACK test lead probe to terminal "B."
 - a. If meter "Beeps" once, diode is OK.
 - b. If meter makes a continuous tone, diode is defective (shorted). Replace ground harness or ground terminal.
 - c. If meter displays "OL," diode is defective (open). Replace ground harness or ground terminal.
6. Now repeat test for terminal "C" Results must be the same.

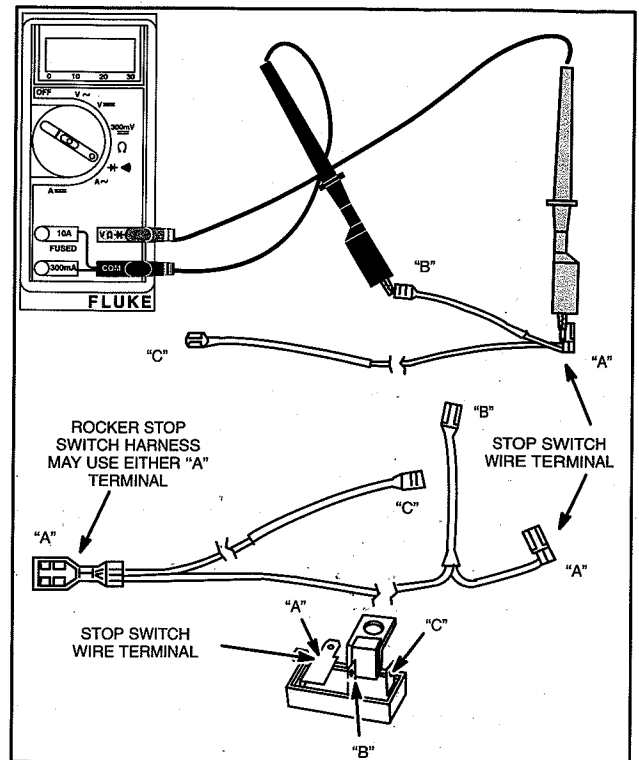

Fig. 15 – Testing Ground Wire Harness And Stop Terminal

Testing Rocker Stop Switch

The rocker stop switch can be checked for continuity using the digital multimeter, Tool #19390.

Note: If rocker stop switch is mounted in carburetor cover, it will be necessary to remove cover to access terminals on switch.

The following test will be made with the meter in the "Diode Test Position" \rightarrow .

When meter test leads are attached to switch terminals, and switch is in "STOP" position, a continuous tone indicates continuity, With switch in "RUN" position, no tone indicates no continuity (incomplete circuit). An incomplete circuit will be displayed as "OL."

1. Disconnect stop switch wire from spade terminal on stop switch. Leave ground lead attached to stop switch. Move switch to "STOP" ("O") position.
2. Insert red test lead into $V \Omega \rightarrow$ receptacle in meter.
3. Insert black test lead into **COM** receptacle in meter.
4. Rotate selector to \rightarrow position.
5. Attach either meter test lead to spade terminal. Attach other lead to switch mounting surface or a good ground Fig. 16.
 - a. Meter should make a continuous tone.
6. Now, move switch to "RUN" ("I") position.
 - a. Meter should display "OL."

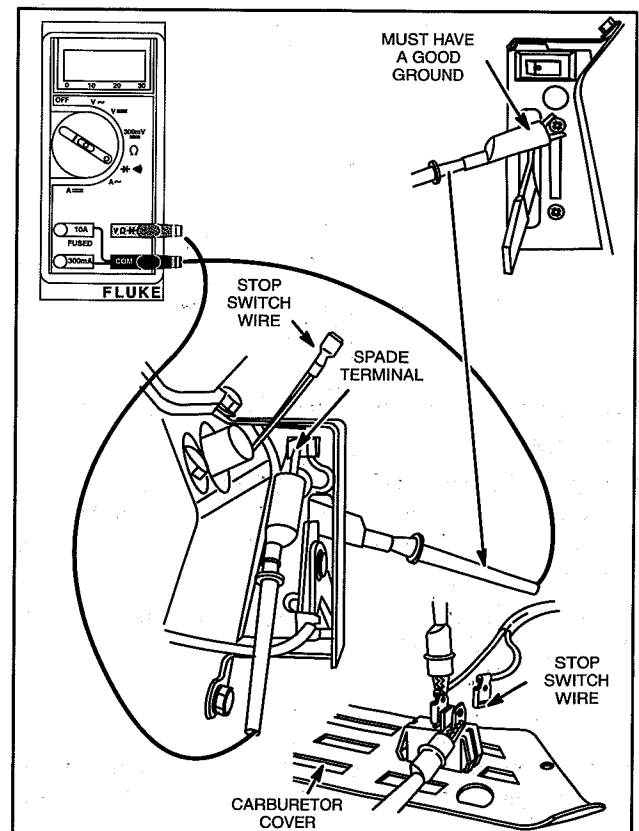

Fig. 16 – Testing Rocker Stop Switch

1. The first part of the document discusses the importance of maintaining accurate records of all transactions. It emphasizes that this is crucial for the company's financial health and for providing reliable information to stakeholders.

2. The second part of the document outlines the specific procedures for recording transactions. It details the steps from identifying a transaction to entering it into the accounting system, ensuring that all necessary details are captured.

3. The third part of the document discusses the role of the accounting department in monitoring and controlling the company's financial performance. It highlights the importance of regular reviews and the use of financial ratios to assess the company's position.

4. The fourth part of the document addresses the challenges faced by the accounting department in maintaining accurate records. It identifies common issues such as data entry errors and incomplete documentation, and offers strategies to minimize these risks.

5. The fifth part of the document discusses the importance of internal controls in the accounting process. It explains how these controls help to prevent fraud and ensure the integrity of the financial data.

6. The sixth part of the document outlines the responsibilities of the accounting department in providing financial information to management. It emphasizes the need for timely and accurate reporting to support decision-making.

7. The seventh part of the document discusses the role of the accounting department in tax compliance. It highlights the importance of staying up-to-date on tax laws and regulations to ensure the company is in full compliance.

8. The eighth part of the document discusses the importance of communication between the accounting department and other departments. It emphasizes the need for clear and consistent information flow to ensure the accuracy of the financial data.

9. The ninth part of the document outlines the specific responsibilities of the accounting department in preparing financial statements. It details the steps from gathering data to the final review and approval of the statements.

10. The tenth part of the document discusses the importance of the accounting department in providing financial information to external stakeholders. It highlights the need for transparency and the use of clear and concise language in financial reports.

11. The eleventh part of the document discusses the role of the accounting department in providing financial information to the public. It emphasizes the importance of accuracy and the use of appropriate disclosure techniques.

12. The twelfth part of the document discusses the importance of the accounting department in providing financial information to the government. It highlights the need for compliance with tax laws and the use of accurate data in financial reports.

13. The thirteenth part of the document discusses the role of the accounting department in providing financial information to the media. It emphasizes the importance of accuracy and the use of clear and concise language in financial reports.

14. The fourteenth part of the document discusses the importance of the accounting department in providing financial information to the public. It highlights the need for transparency and the use of appropriate disclosure techniques.

Section 3

CARBURETION

| Section Contents | Page |
|--|------|
| CARBURETOR | |
| Carburetor Types | 2 |
| REMOVE | |
| 290700 – 380700 | 2 |
| 290400 – 350400 | 20 |
| 351400, 380400 | 21 |
| DISASSEMBLE | |
| 290700 – 303700 (350700 After 95093000) (Aisan Carburetor) | 3 |
| 350700 Before 95093000 (Mikuni Carburetor) | 8 |
| 351400, 351700, 380400, 380700 | 13 |
| 290400 – 303400 (350400 After 95073100) (Nikki Carburetor) | 23 |
| 350400 Before 95073100 (Mikuni Carburetor) | 29 |
| ASSEMBLE | |
| 290700 – 303700 (350700 After 95093000) (Aisan Carburetor) | 6 |
| 350700 Before 95093000 (Mikuni Carburetor) | 11 |
| 351400, 351700 380400, 380700 | 16 |
| 290400 – 303400 (350400 After 95073100) (Nikki Carburetor) | 26 |
| 350400 Before 95073100 (Mikuni Carburetor) | 32 |
| INSTALL | |
| 290700 – 350700 | 18 |
| 351700, 380700 | 19 |
| 290400 – 350400 | 34 |
| 351400, 380400 | 35 |
| ADJUST | |
| 290000 – 350000 | 37 |
| Engines Equipped With Performance Control™ Electronic Governor | 39 |
| 351400 – 380400, 351700 And 380700 | 40 |
| ANTI-AFTERFIRE SYSTEM | |
| Testing | 42 |
| FUEL PUMP | 43 |
| INLINE FUEL FILTER | 44 |

SEE SECTION 1 FOR AIR CLEANER MAINTENANCE PROCEDURES.

Carburetor Types

Two types of carburetors are used on Vanguard™ OHV V-Twin engines:

One-piece Flo-Jet side-draft on Model Series 290700, 294700, 303700, 350700, 351400, 351700, 380400 and 380700.

Two-piece Flo-Jet down-draft on Model Series 290400, 303400 and 350400. Both types use similar systems of operation.

3

Remove Carburetor – Vertical Crankshaft Models 290700 – 380700

Note All Models: If engine is equipped with anti-afterfire solenoid, remove blower housing so that solenoid wire can be properly routed during reassembly. Disconnect anti-afterfire solenoid wire from equipment switch wire.

Current style: (Round cartridge)

Remove the following parts, Fig. 1.

1. Air cleaner cover, cartridge and pre-cleaner.
2. Three screws and breather deflector.
3. Two carburetor mounting nuts.
4. Air cleaner base and breather tube.

Early style: (Square cartridge)

Remove the following parts, Fig. 2.

1. Air cleaner cover.
2. Four screws.
3. Air cleaner base and breather tube
4. Carburetor mounting screws.

All Models:

1. Remove two screws and choke control bracket, Fig. 3.
2. Disconnect choke link from carburetor.

Note: If engine is equipped with anti-afterfire solenoid, air cleaner bracket must be removed before removing carburetor, Fig. 3.

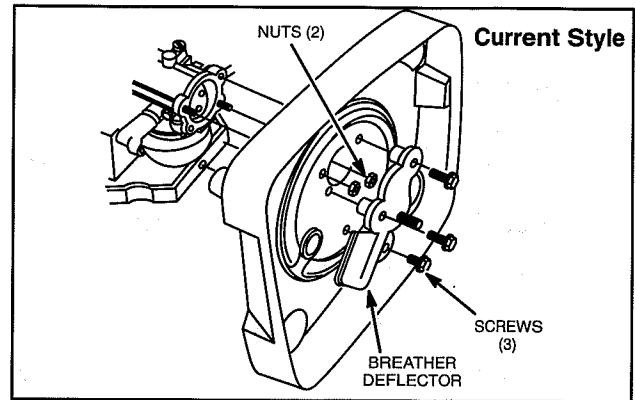

Fig. 1 – Remove Air Cleaner Base

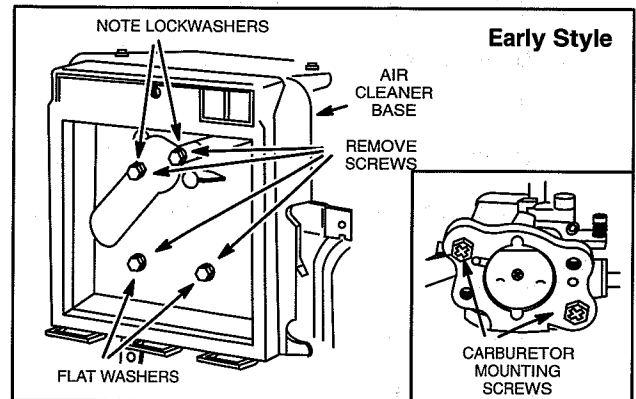

Fig. 2 – Remove Air Cleaner Base

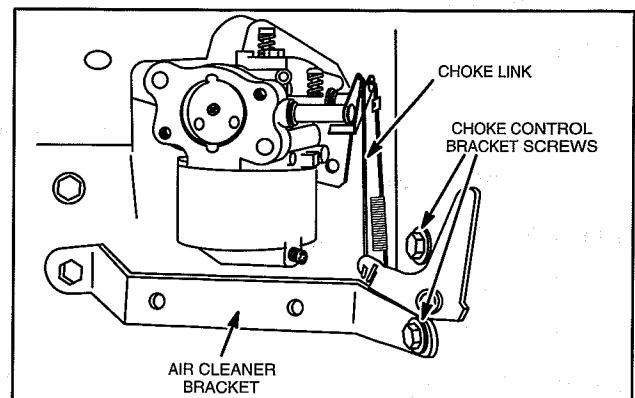

Fig. 3 – Removing Choke Control Bracket

3. Disconnect fuel line at carburetor.
4. Disconnect governor link spring from throttle lever
5. Disconnect governor link.
6. Remove carburetor gaskets and spacer, Fig. 4.
 - a. Discard gaskets.

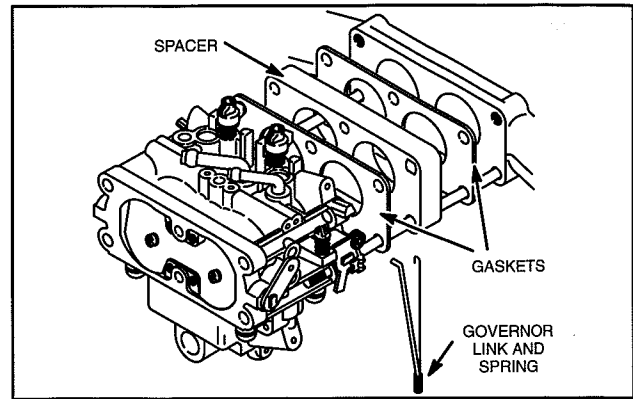

Fig. 4 – Removing Carburetor

**Disassemble Carburetor – Aisan Carburetor
Engine Models 290700 – 303700
(350700 After 95093000)**

Note: Engine Model 350700 manufactured after 95093000 are equipped with an Aisan carburetor.

1. Remove anti-afterfire solenoid or bowl screw and washer, Fig. 5.
2. Remove float bowl.
 - a. Discard bowl gasket.

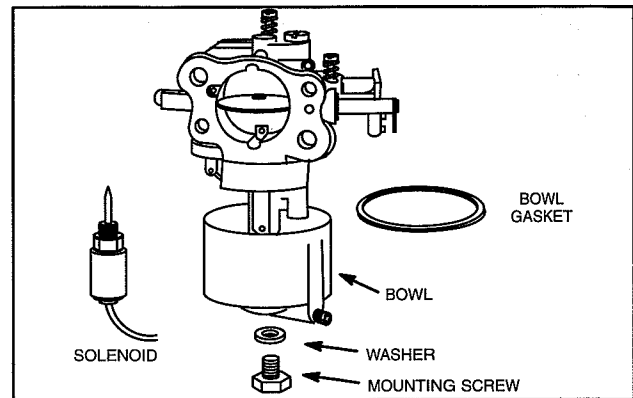

Fig. 5 – Removing Float Bowl

3. Remove float hinge pin, float and inlet needle, Fig. 6.

Note: Float hinge pin is a press fit. Use care when removing.

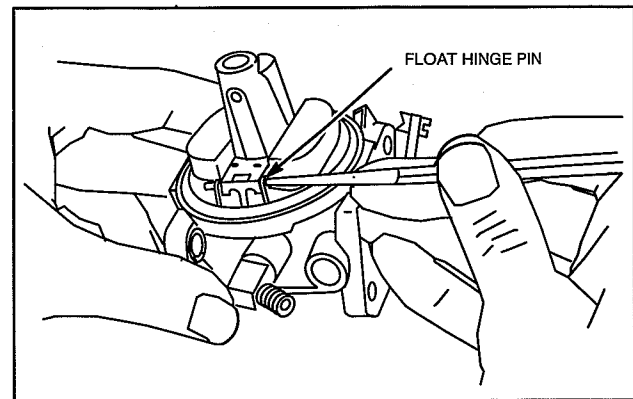

Fig. 6 – Remove Float

4. Remove fixed main jet using screwdriver, Tool # 19062, Fig. 7.
5. Reach into carburetor throat with flat blade screwdriver and push down on end of emulsion tube.

Note: Consult the illustrated parts list for correct part number for special high altitude jet, if required.

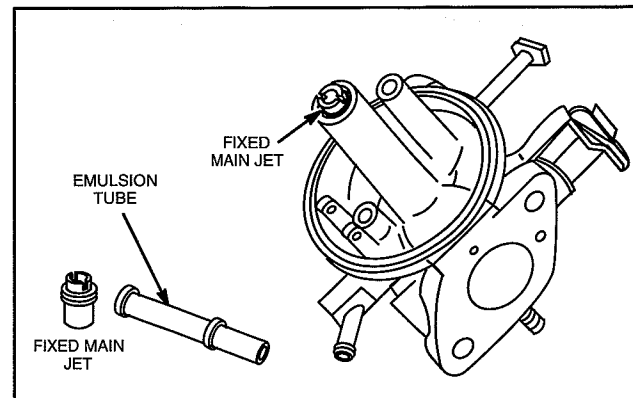

Fig. 7 – Remove Emulsion Tube

6. Remove idle jet plug and idle jet, Fig. 8.

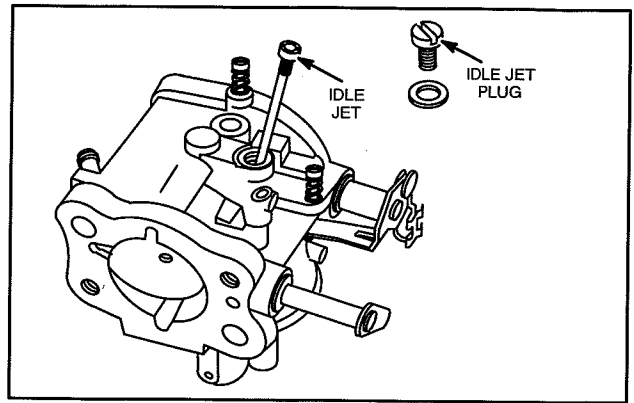

Fig. 8 – Remove Idle Jet

7. If idle mixture screw is equipped with adjustment limiter cap, use a pliers to remove before removing idle mixture screw, Fig. 9.

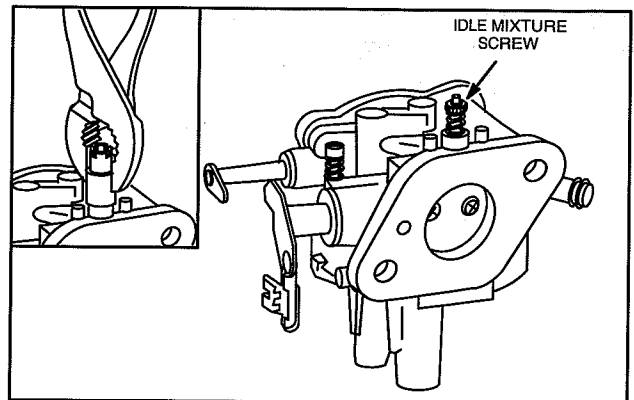

Fig. 9 – Remove Idle Mixture Screw

8. Mark throttle plate before removing so that it may be re-installed in the same position, Fig. 10. Top and bottom edges are beveled.

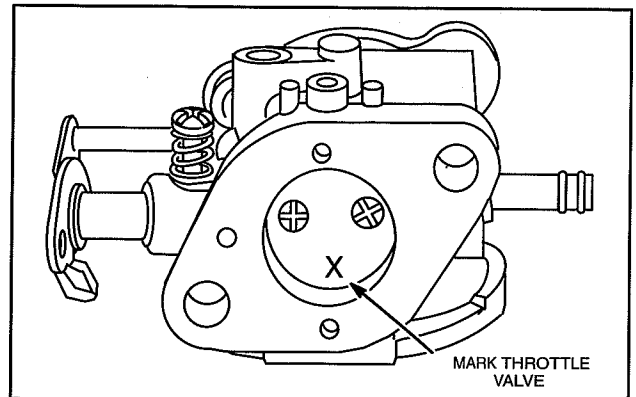

Fig. 10 – Mark Throttle Plate

9. Use a punch as shown and remove throttle shaft welch plug, Fig. 11.

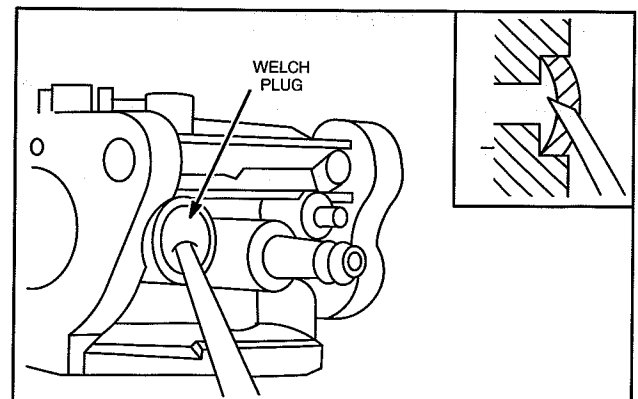

Fig. 11 – Remove Welch Plug

10. Remove snap ring and washer, Fig. 12.
11. Remove throttle shaft, collar and seal.

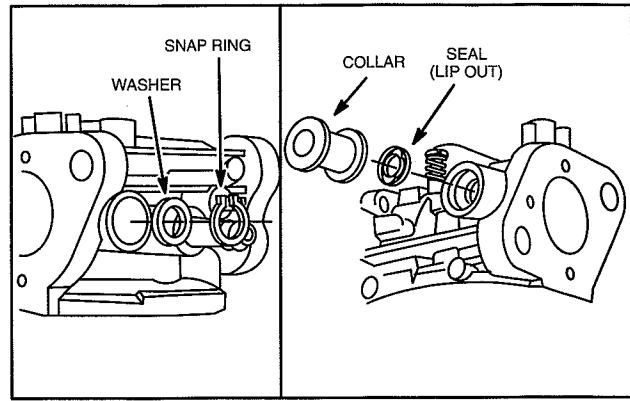

Fig. 12 – Remove Throttle Shaft

12. Remove screw and choke plate, Fig. 13.
 13. Remove “E” ring, choke shaft and seal.
- Note:** Carburetor body has a detent ball and spring that keeps tension on choke shaft. Use care when removing choke shaft

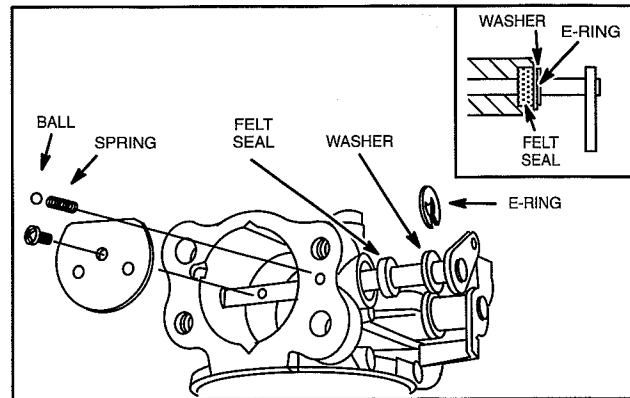

Fig. 13 – Remove Choke Plate

14. Remove transitional hole welch plug from top of carburetor, Fig. 14.
- This completes the carburetor disassembly procedure.

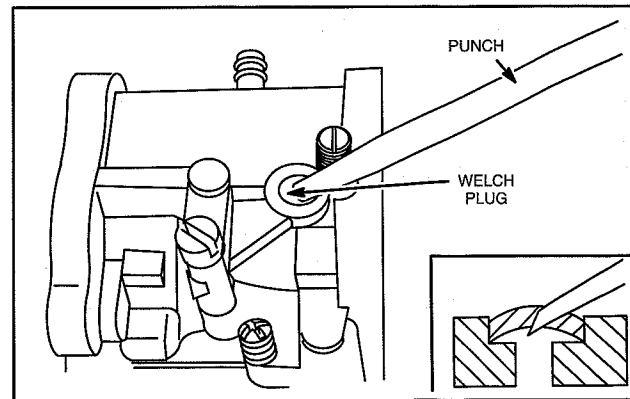

Fig. 14 – Remove Welch Plug

Clean Carburetor

Remove gasket material from mounting surfaces. Gummy or dirty carburetors should be cleaned in a commercial carburetor cleaner. DO NOT soak longer than 15 minutes. DO NOT soak rubber, neoprene or plastic parts in carburetor cleaner.

Inspect Carburetor

Inspect all parts for wear, cracks, nicks and burrs. Inspect float for leaks. Replace damaged parts.

Check Throttle, Choke Shaft And Body For Wear

1. Lay carburetor on flat surface and check throttle and choke shaft clearance as shown in Fig. 15. Throttle shaft and choke shaft clearance must not exceed .25 mm (.010").

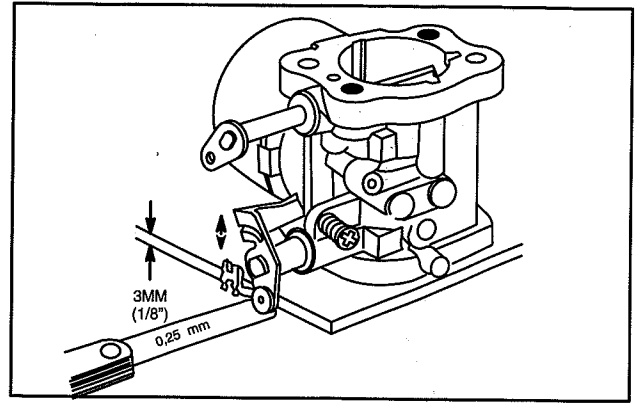

Fig. 15 – Check Clearance

2. Inspect throttle shaft and choke shaft for wear. Replace if worn, Fig. 16. If carburetor body is worn, replace carburetor.

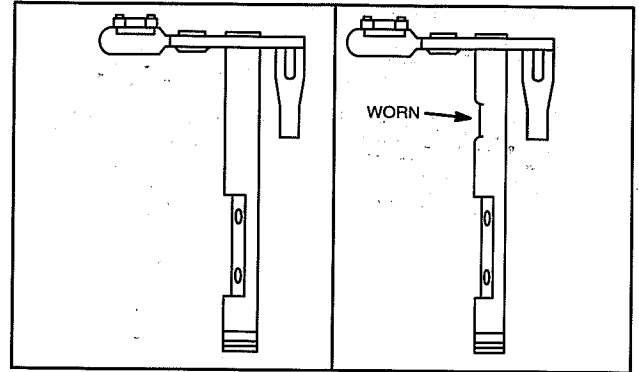

Fig. 16 – Checking Throttle And Choke Shaft

Assemble Carburetor – Aisan Carburetor Engine Models 290700 – 303700 (350700 After 95093000)

When assembling carburetor, use new seals and gaskets.

1. Install new transitional hole idle port welch plug, Fig. 17.
2. Use a round punch and tap in plug until it is flat,
3. Use a sealant such as Permatex® #2 or nail polish on outside diameter of plug to prevent air leaks.

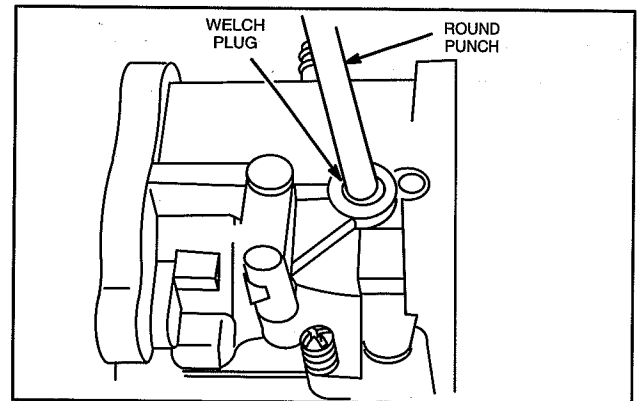

Fig. 17 – Install Welch Plug

4. Assemble new throttle shaft seal with sealing lip out.
 5. Install throttle shaft with collar.
 6. Install washer and snap ring, Fig. 18.
 7. Install throttle plate.
- Note: Use LOCTITE® 222 on screw threads.**
8. Install new throttle shaft welch plug.
 - a. Use round punch and tap in plug until it is flat.
 - b. Use sealant on outside diameter of welch plug to prevent leaks.

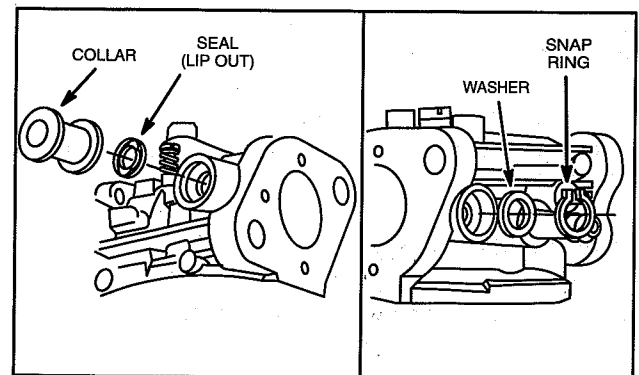

Fig. 18 – Install Throttle Shaft

9. Install new "E" ring, washer and felt seal onto choke shaft.
10. Insert spring and check ball in to spring pocket.
11. Install choke shaft
12. Install choke plate as shown, Fig. 19.

Note: Use **LOCTITE® 222** on screw threads.

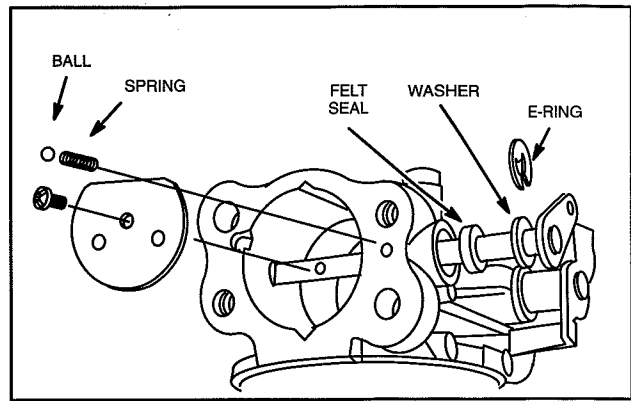

Fig. 19 – Install Choke Shaft

13. Assemble inlet needle retainer to inlet needle and assemble to float, Fig. 20.
14. Install float.
15. Install emulsion tube and fixed main jet.

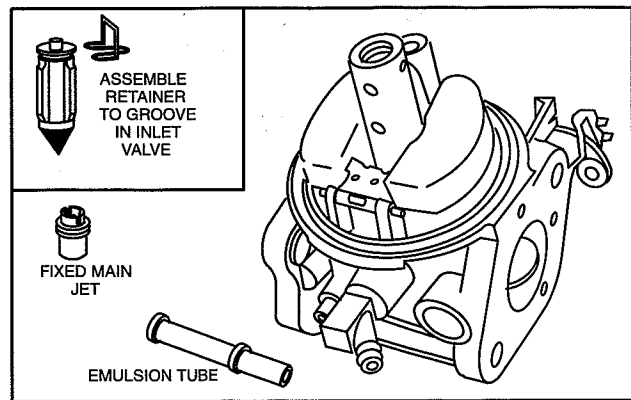

Fig. 20 – Install Float

16. Check float adjustment, Fig. 21.
 - a. Hold carburetor in vertical position with float hinge up as shown.
 - b. Float should be parallel with bowl mounting surface.
 - c. Bend tang if required.

DO NOT press on float to adjust.

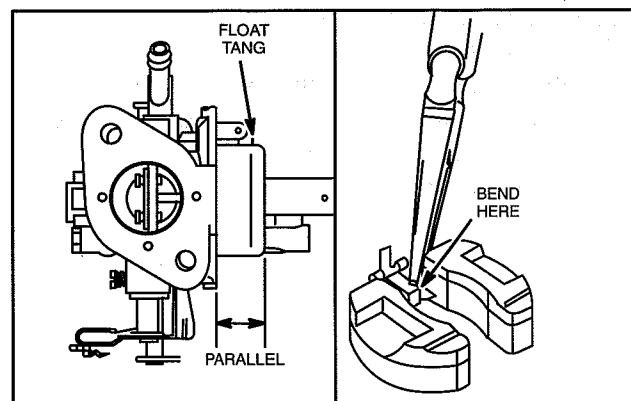

Fig. 21 – Check Float Height

17. Install idle jet, plug and gasket, Fig. 22.

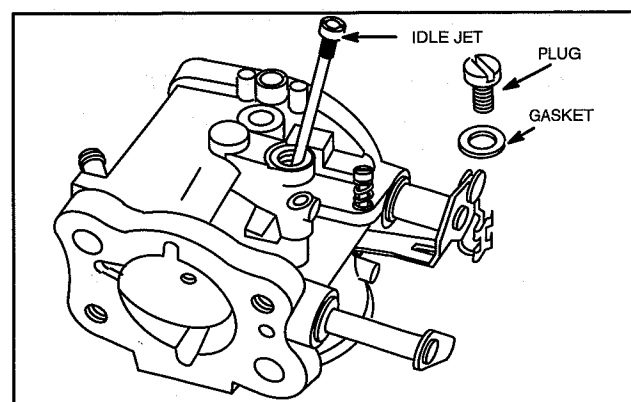

Fig. 22 – Install Idle Jet

18. Install idle mixture screw and spring, Fig. 23.
DO NOT tighten valve.
DO NOT install limiter cap at this time.

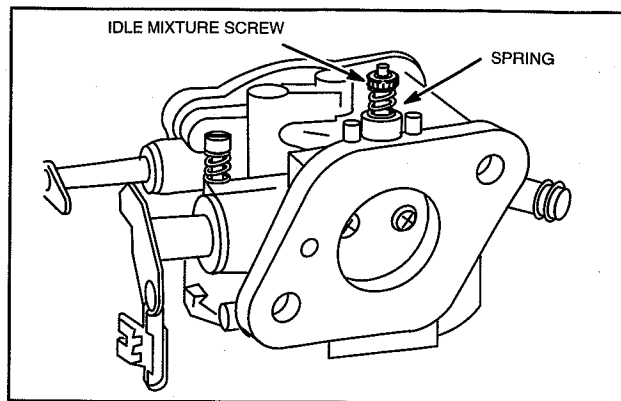

Fig. 23 – Install Idle Mixture Screw

19. Install bowl gasket, float bowl, washer and screw or anti-afterfire solenoid, if equipped.
a. Position bowl drain as shown, Fig. 24.
b. Torque screw or solenoid to 5.0 Nm (45 in. lbs.).

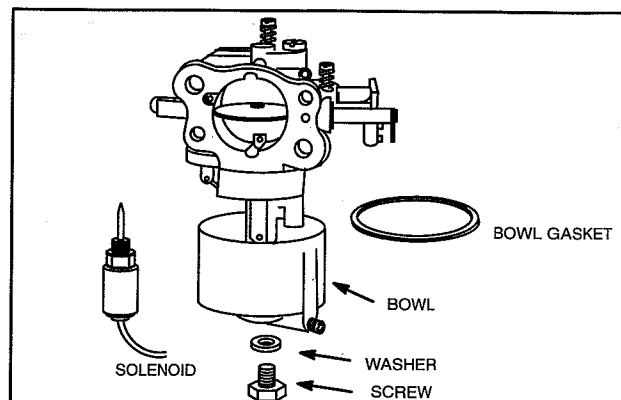

Fig. 24 – Install Float Bowl

**Disassemble Carburetor –
Mikuni Carburetor
Engine Model 350700 (Before 95093000)**

1. Remove anti-afterfire solenoid or bowl screw, washer and bowl, Fig. 25.
a. Remove bowl gasket.

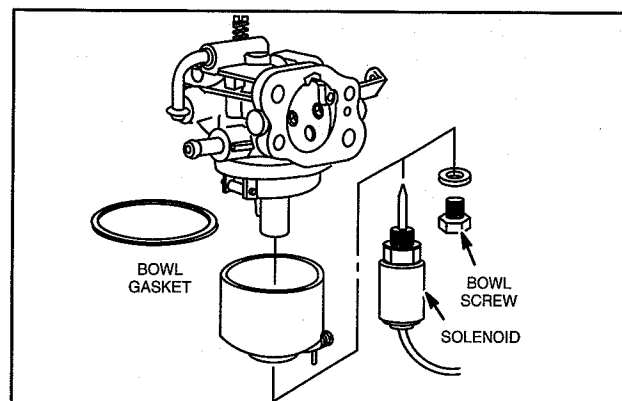

Fig. 25 – Removing Float Bowl

2. Remove fixed main jet using screwdriver Tool #19061.
3. Remove float and inlet needle, Fig. 26.
Note: Float hinge pin is swaged on one end. Drive hinge pin out from side opposite swage.

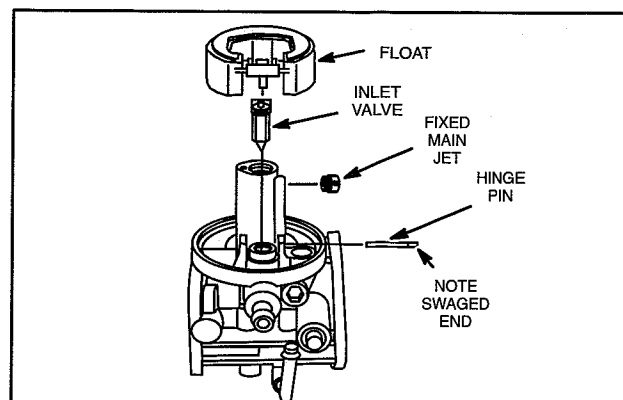

Fig. 26 – Removing Float

4. Remove emulsion tube, Fig. 27.

Note: If carburetor is equipped with solenoid, first remove solenoid seat, then remove emulsion tube, Fig. 27.

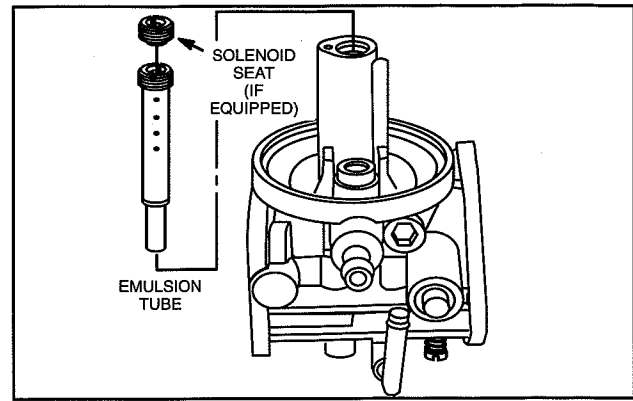

Fig. 27 – Removing Emulsion Tube

If idle mixture screw is equipped with adjustment limiter cap, use a pliers to remove it before removing idle mixture screw.

5. Remove idle mixture valve and spring, Fig. 28.
 - a. Remove pilot jet.

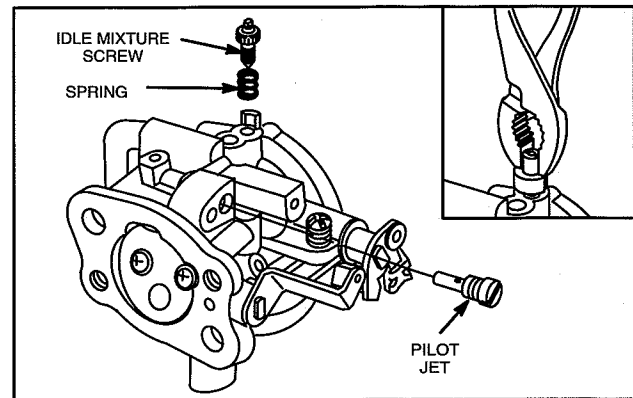

Fig. 28 – Remove Idle Mixture Screw

6. Mark throttle plate before removing so that it may be re-installed in the same position. Top and bottom edges are beveled.
 - a. Remove retainer
 - b. Remove throttle shaft and spacer, Fig. 29.
 - c. Remove seals.

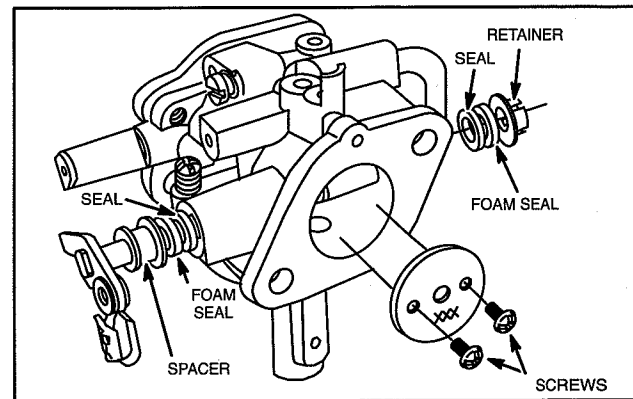

Fig. 29 – Remove Throttle Shaft

7. Remove choke plate, shaft and seal, Fig. 30.

Note: Carburetor body has a ball and spring that keeps tension on choke shaft. Use care when removing choke shaft

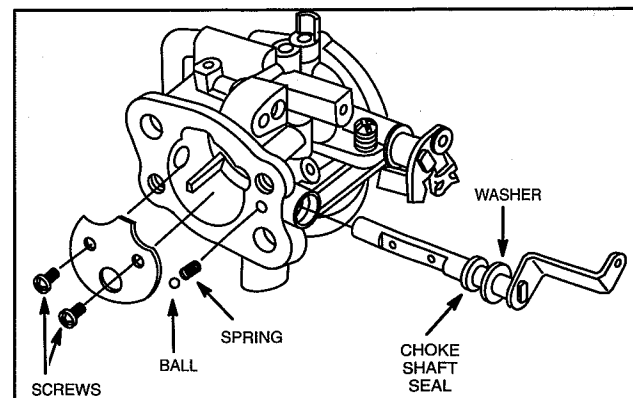

Fig. 30 – Remove Choke Shaft

Remove Fuel Inlet Body And Seat

The fuel inlet body must be removed before the inlet seat can be removed.

1. Use self-threading screw #93029 from flywheel puller, Tool #19165. Thread screw into seat body 3-4 turns. Then, remove the screw, Fig. 31.

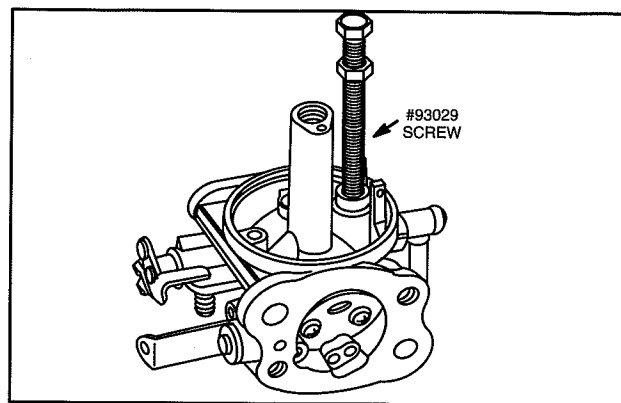

Fig. 31 – Remove Inlet Body

2. Install 1/4" x 20 nut #92278 and washer #224061 from 19332 Tool Kit onto screw.
3. Place a 1/4" drive 9 mm (3/8") socket over seat body.
4. Install screw, washer and nut. Thread nut down on washer.
5. Continue turning until seat body is removed, Fig. 32.
 - a. Remove fuel inlet seat.

This completes the carburetor disassembly procedure.

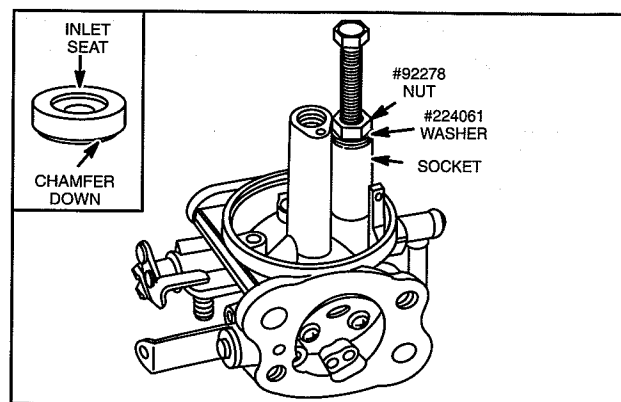

Fig. 32 – Remove Inlet Seat

Clean Carburetor

Remove gasket material from mounting surfaces. Gummy or dirty carburetors should be cleaned in a commercial carburetor cleaner. DO NOT soak longer than 15 minutes. DO NOT soak rubber, neoprene or plastic parts in commercial carburetor cleaner.

Inspect Carburetor

Inspect all parts for wear, cracks, nicks and burrs. Inspect float for leaks. Replace damaged parts.

Check Throttle, Choke Shaft And Body For Wear

1. Lay carburetor on flat surface and check throttle and choke shaft clearance as shown in Fig. 33. Throttle shaft and choke shaft clearance must not exceed .25 mm (.010").

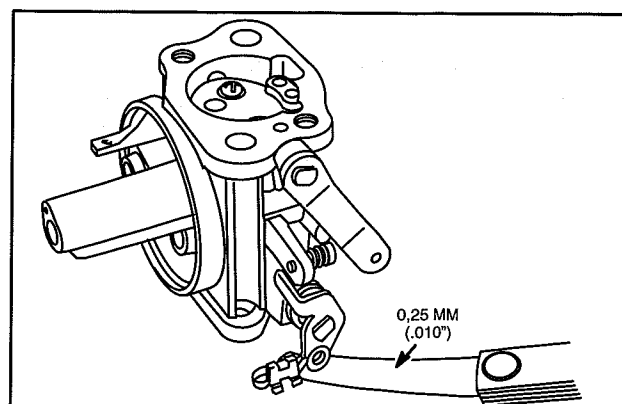

Fig. 33 – Check Clearance

2. Inspect throttle shaft and choke shaft for wear.
Replace if worn, Fig. 34.

If carburetor body is worn, replace carburetor.

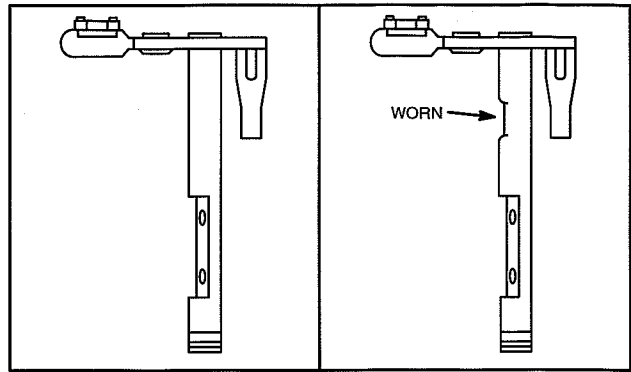

Fig. 34 – Checking Throttle And Choke Shaft

Assemble Carburetor – Mikuni Carburetor Engine Model 350700 (Before 95093000)

When assembling carburetor, use new seals and gaskets.

Install Fuel Inlet Seat And Body

1. Install new inlet seat with chamfered end down, Fig. 35.
2. Press in new body using Tool #19135.

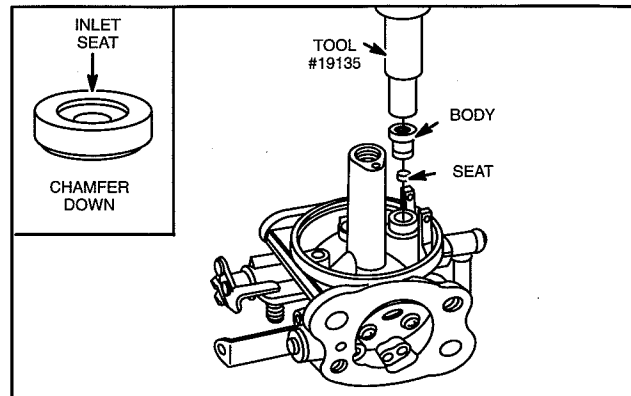

Fig. 35 – Install Inlet Body And Seat

3. Install new throttle shaft seals with sealing lip out.
4. Install throttle shaft with spacer and foam seal.
5. Install foam seal and retainer, Fig. 36.
6. Install throttle plate.

Note: Use **LOCTITE® 222** on screw threads.

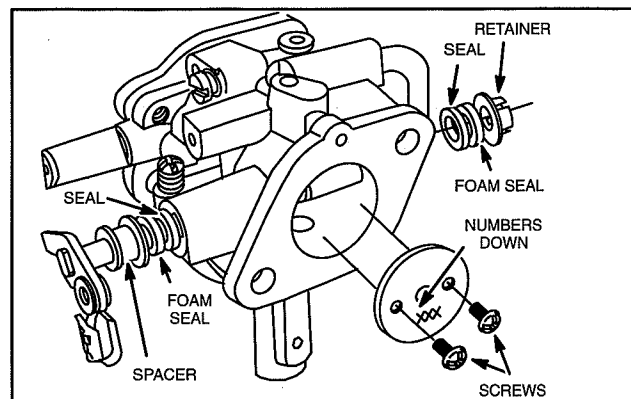

Fig. 36 – Install Throttle Shaft

7. Install new choke shaft seal with sealing lip out.
8. Assemble washer onto choke shaft.
9. Insert spring and check ball in to spring pocket and compress with a small round punch.
10. Push choke shaft into hole until ball engages groove in choke shaft, Fig. 37.
11. Install choke plate as shown, Fig. 37.

Note: Use **LOCTITE® 222** on screw threads.

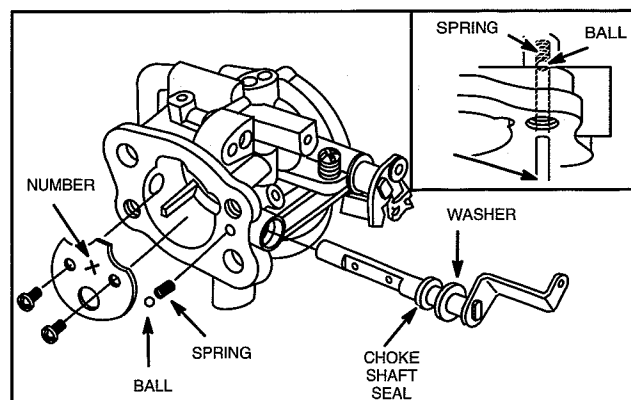

Fig. 37 – Install Choke Shaft

12. Assemble inlet needle retainer to inlet needle and assemble to float.
13. Install float
 - a. Install float hinge pin with swaged end out, Fig. 38.

Note: Float level is not adjustable.

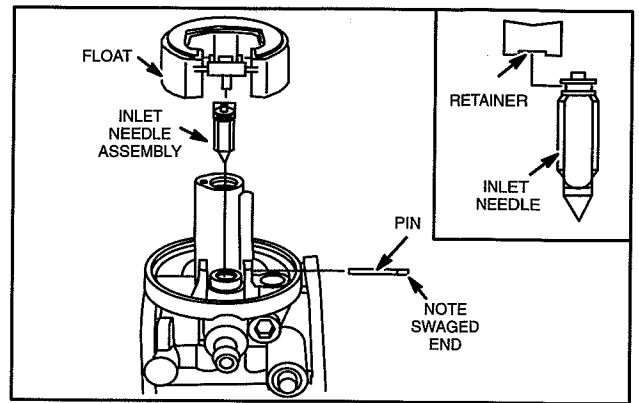

Fig. 38 – Install Float

14. Install pilot jet.
 15. Install idle mixture screw and spring, Fig. 39.
- DO NOT** tighten screw.
DO NOT install limiter cap at this time.

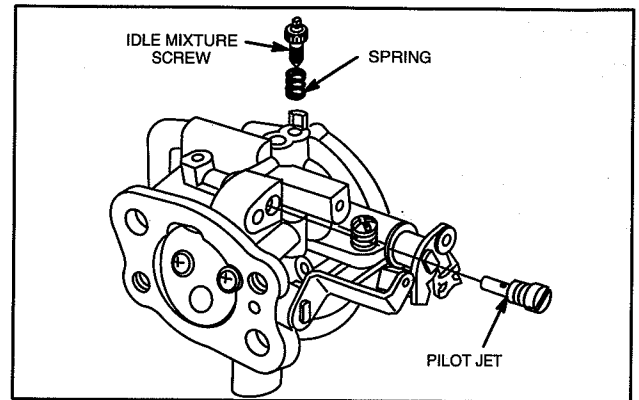

Fig. 39 – Install Idle Mixture Screw

16. Install emulsion tube using screwdriver Tool #19062.
17. If carburetor is equipped with anti-afterfire solenoid, install solenoid seat, Fig. 40.
18. Install fixed main jet using screwdriver Tool #19061.

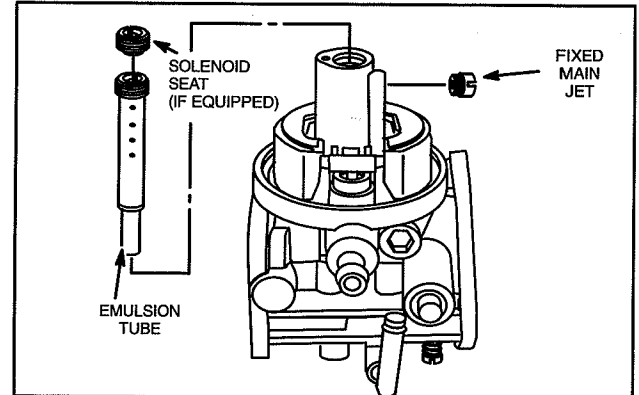

Fig. 40 – Install Emulsion Tube

19. Install bowl gasket, float bowl, washer and screw or anti-afterfire solenoid, if equipped.
 - a. Position bowl drain as shown, Fig. 41.
 - b. Torque screw or solenoid to 5.0 Nm (45 in. lbs.).

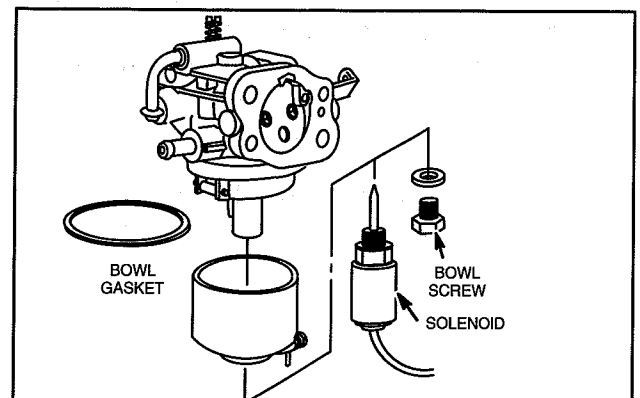

Fig. 41 – Install Float Bowl

**Disassemble Carburetor –
Engine Models 351700 And 351400
380700 And 380400**

IMPORTANT: The carburetors used on the vertical crankshaft Models 351700 and 380700, and the horizontal crankshaft Models 351400 and 380400 are similar enough that carburetor disassembly and reassembly procedures can be considered the same. The only significant differences in the carburetors are the location of the idle mixture screws and the fixed main jet orifice sizes.

1. Remove anti-afterfire solenoid with washer.
2. Remove fixed main jet plugs with washers, Fig. 42.

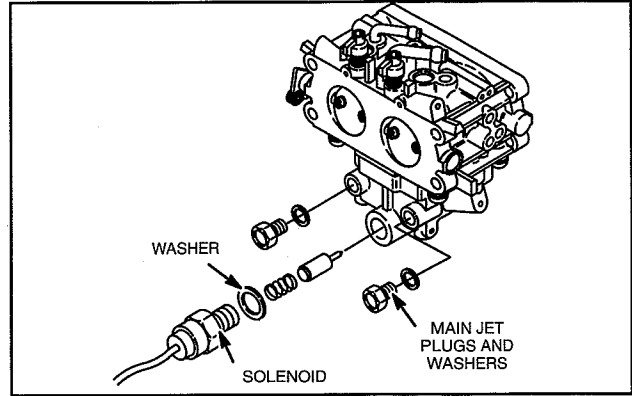

Fig. 42 – Remove Solenoid

3. Remove fixed main jets, Fig. 43.
Note: Carburetor is equipped with a different size fixed main jet for each cylinder. The carburetor is marked “L” (#1 cylinder) and “R” (#2 cylinder). The carburetor is marked in two areas: The carburetor upper body near the choke plate and the lower body near the main jet plugs. See Fig. 43.

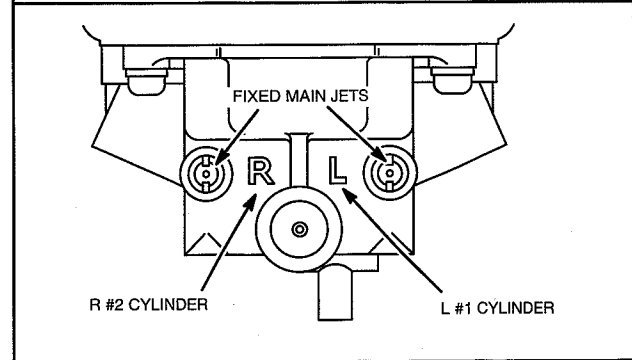
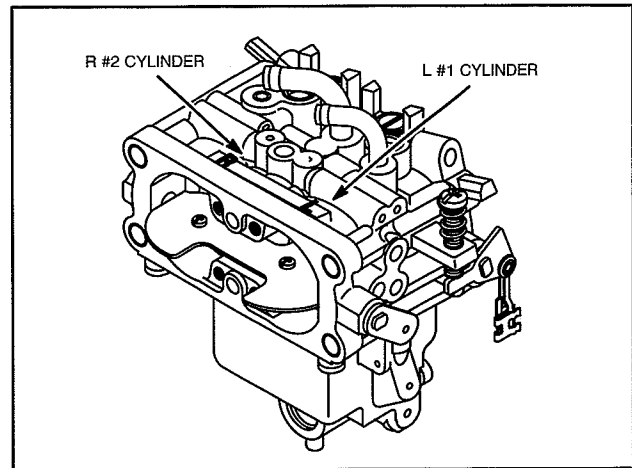

Fig. 43 – Remove Fixed Jets

Fixed Main Jet Sizes

Model 351700:

“L” or #1 cylinder is equipped with #98 main jet.
“R” or #2 cylinder is equipped with #100 main jet.

Model 351400:

“L” or #1 cylinder is equipped with #94 main jet.
“R” or #2 cylinder is equipped with #98 main jet.

Model 380700:

“L” or #1 cylinder is equipped with #118 main jet.
“R” or #2 cylinder is equipped with #116 main jet.

Model 380400:

“L” or #1 cylinder is equipped with #110 main jet.
“R” or #2 cylinder is equipped with #114 main jet.

4. Remove carburetor lower body screws and lift lower body straight away from upper body, Fig. 44.
 - a. Discard gasket.

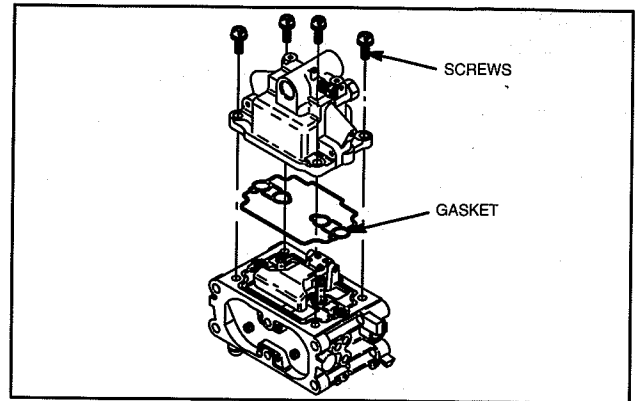

Fig. 44 – Remove Lower Body

5. Remove pilot jets, Fig. 45.
6. Remove float bowl drain screw and spring.

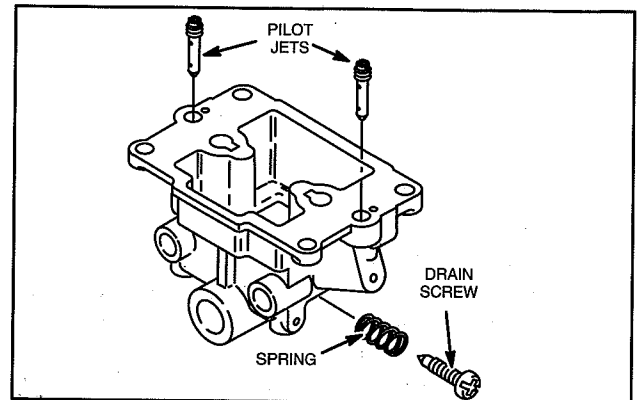

Fig. 45 – Remove Pilot Jets

7. Drive out float hinge pin from side opposite throttle lever.
 - a. Remove float and fuel inlet needle assembly, Fig. 46.

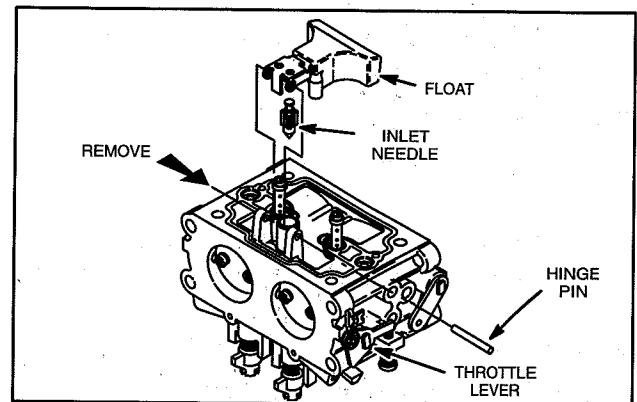

Fig. 46 – Remove Float

If idle mixture screws are equipped with adjustment limiter caps, use a pliers to remove them before removing idle mixture screws.

8. Remove idle mixture screws and springs, Fig. 47.

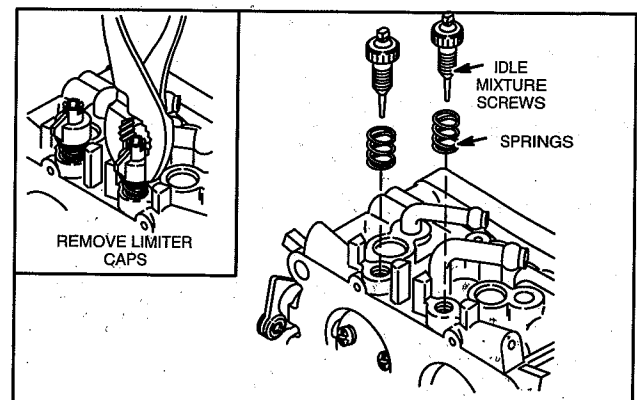

Fig. 47 – Remove Idle Mixture Screws

9. Mark throttle plate before removing so that it may be re-installed in the same position. Top and bottom edges are beveled.
10. Remove throttle shaft, spacer and seal, Fig. 48.

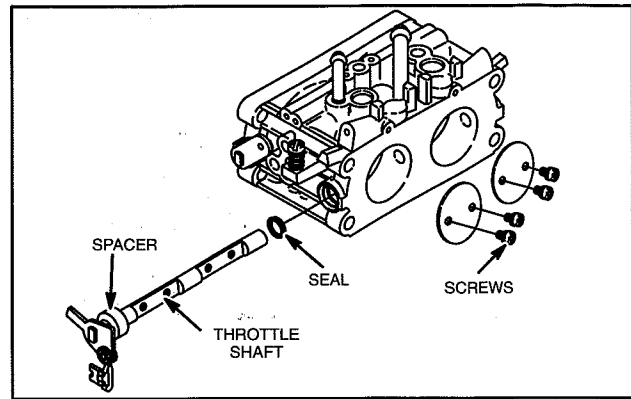

Fig. 48 – Remove Throttle Shaft

11. Mark choke plate so it may be returned to its original position.
 12. Remove choke shaft and seal, Fig. 49.
- This completes the carburetor disassembly procedure.

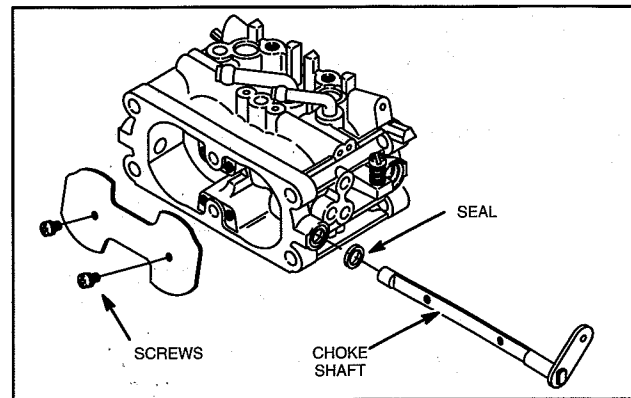

Fig. 49 – Remove Choke Shaft

Clean Carburetor

Remove gasket material from mounting surfaces. Gummy or dirty carburetors should be cleaned in a commercial carburetor cleaner. DO NOT soak longer than 15 minutes. DO NOT soak rubber, neoprene or plastic parts in commercial carburetor cleaner.

Inspect Carburetor

Inspect all parts for wear, cracks, nicks and burrs. Inspect float for leaks. Replace damaged parts.

Check Throttle, Choke Shaft And Body For Wear

1. Lay carburetor on 6mm (1/4") raised flat surface and check throttle and choke shaft clearance as shown in Fig. 50.

Throttle shaft and choke shaft clearance must not exceed .25 mm (.010").

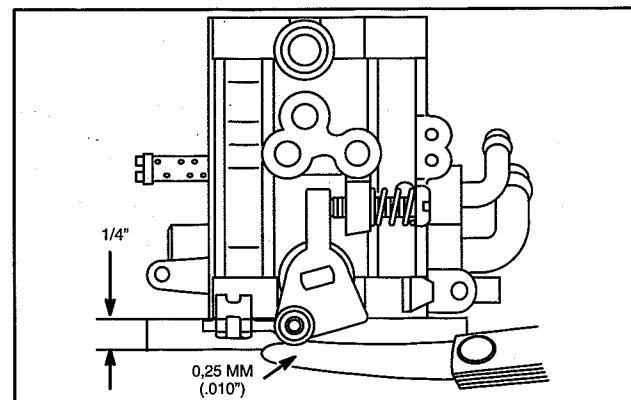

Fig. 50 – Check Clearance

2. Inspect throttle shaft and choke shaft for wear. Replace if worn, Fig. 51.
If carburetor body is worn, replace carburetor.

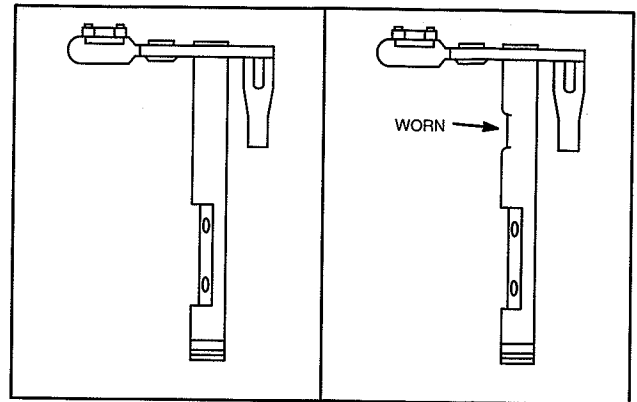

Fig. 51 – Check Throttle And Choke Shaft

Assemble Carburetor – Engine Models 351700 And 351400 380700 And 380400

When assembling carburetor, use new seals and gaskets.

1. Install new throttle shaft seal with sealing lip out.
2. Install throttle shaft with spacer, Fig. 52.

Important: Install one throttle plate at a time. Check throttle shaft for freedom of operation before installing other throttle plate.

Note: Use **LOCTITE® 222** on screw threads.

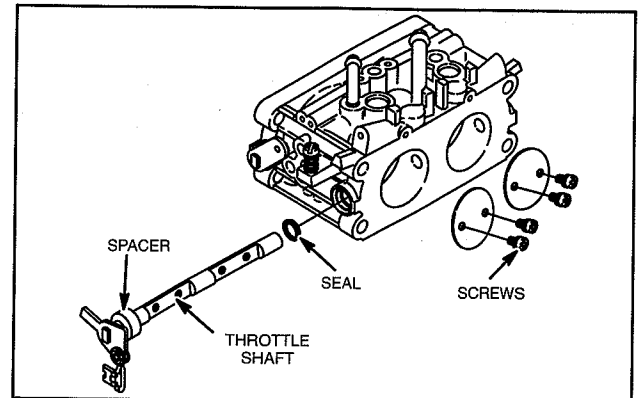

Fig. 52 – Install Throttle Shaft

3. Install new choke shaft seal with sealing lip out.
4. Install choke shaft, Fig. 53.

Note: Use **LOCTITE® 222** on screw threads.

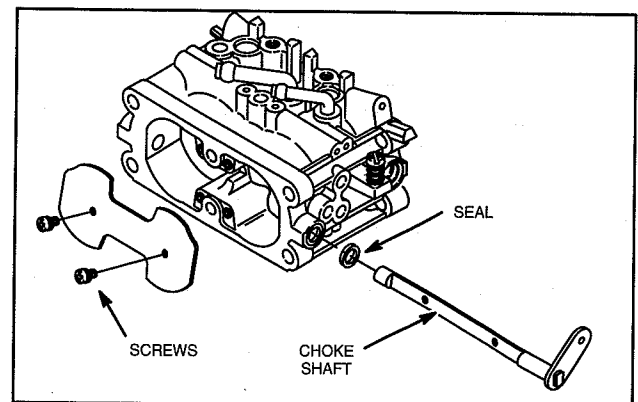

Fig. 53 – Install Choke Shaft

5. Assemble inlet needle to float and install float assembly, Fig. 54.

a. Install float hinge pin from throttle lever side.

Important: Be sure float hinge pin is flush with float support or hinge pin will interfere with lower body.

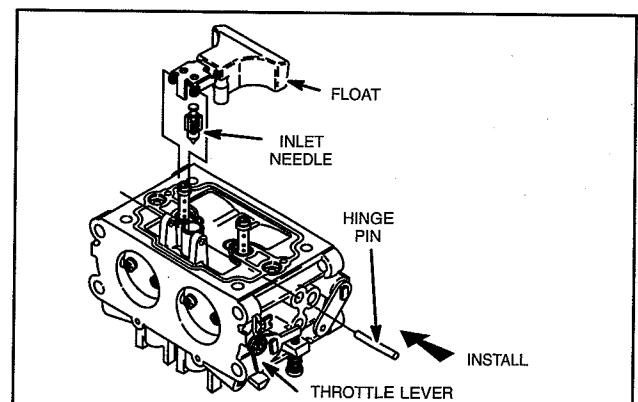

Fig. 54 – Install Float

- 6. Install idle mixture screws and springs, Fig. 55.
DO NOT tighten screws.
DO NOT install limiter caps at this time.

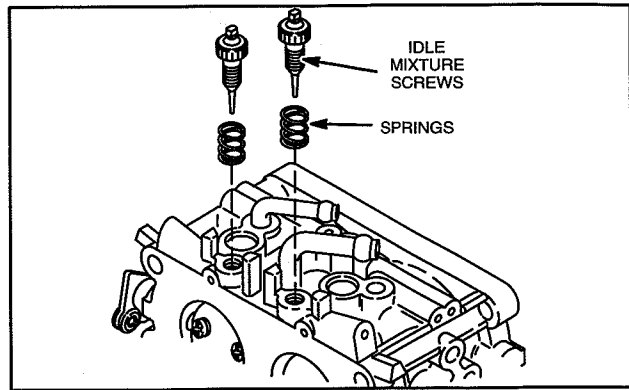

Fig. 55 – Install Idle Mixture Screws

- 7. Install pilot jets, Fig. 56.
- 8. Install fuel bowl drain screw and spring.

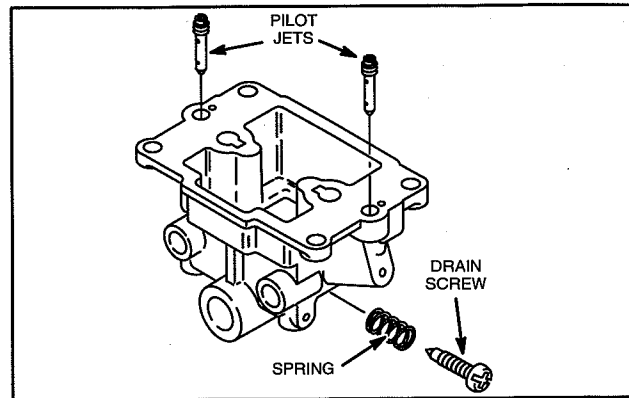

Fig. 56 – Install Pilot Jets

- 9. Install fixed main jets, plugs and washers, Fig. 57.

Model 351700:

"L" or #1 cylinder is equipped with #98 main jet.
"R" or #2 cylinder is equipped with #100 main jet.

Model 351400:

"L" or #1 cylinder is equipped with #94 main jet.
"R" or #2 cylinder is equipped with #98 main jet.

Model 380700:

"L" or #1 cylinder is equipped with #118 main jet.
"R" or #2 cylinder is equipped with #116 main jet.

Model 380400:

"L" or #1 cylinder is equipped with #110 main jet.
"R" or #2 cylinder is equipped with #114 main jet.

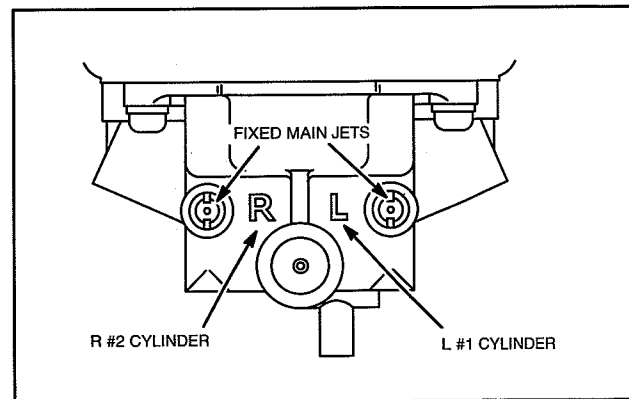

Fig. 57 – Install Main Jets

- 10. Install lower body gasket, Fig. 58.
Make sure gasket does not twist or kink.

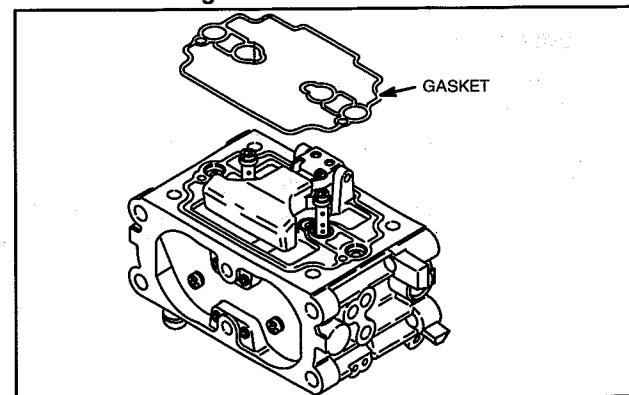

Fig. 58 – Install Gasket

11. Assemble lower body with main jet plugs facing throttle shaft side of carburetor. Make sure gasket remains in position, Fig. 59. Tighten screws securely.
12. Install anti-afterfire solenoid with washer.
 - a. Torque to 10.0 Nm (90 in. lbs.).

See carburetor installation procedure for engine models 351700 and 380700 on page 19.

See carburetor installation procedure for engine models 351400 and 380400 on page 43.

Install Carburetor – Vertical Crankshaft Models 290700 – 350700

Current style: Fig. 60.

1. Assemble gaskets and spacer to manifold.
 - a. Make sure that locating pin on carburetor spacer fits in recess in manifold.
2. Assemble carburetor onto mounting studs.

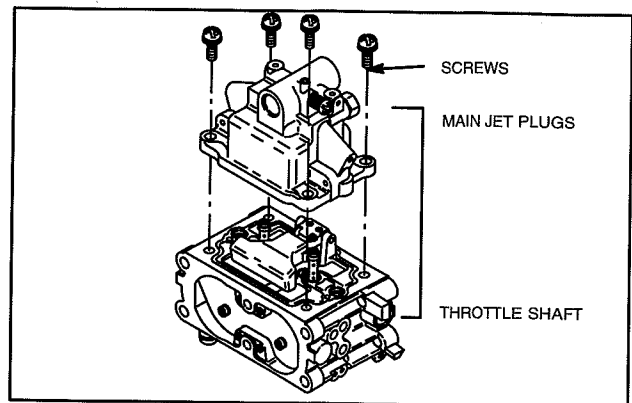

Fig. 59 – Install Lower Body

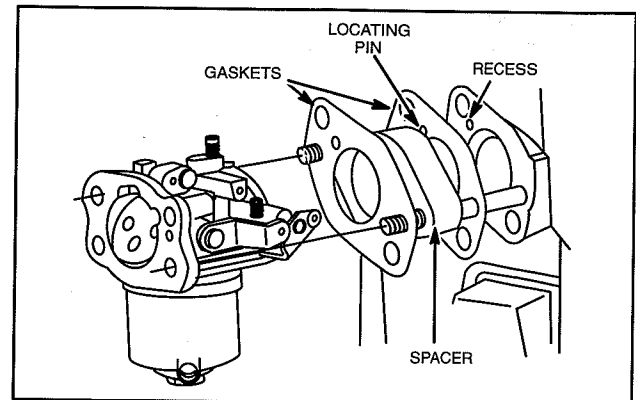

Fig. 60 – Install Carburetor

Early style: Fig. 61.

1. Insert carburetor mounting screws through carburetor, gasket, spacer and gasket, and assemble to manifold.
 - a. Make sure that locating pin on carburetor spacer fits in recess in manifold.
 - b. Torque screws to 7.0 Nm (65 in. lb.).

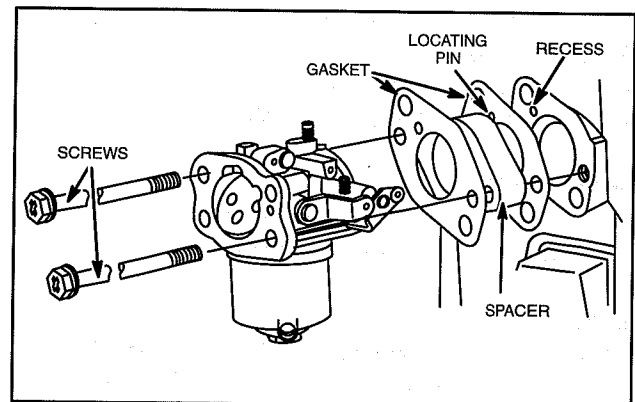

Fig. 61 – Install Carburetor

All Models: Fig. 62.

1. Connect governor link to throttle lever and snap retainer over link.
2. Install governor link spring in loop on retainer.

Note: If carburetor is equipped with anti-afterfire solenoid, route wire under intake manifold and through hole in #1 cylinder shield at this time.

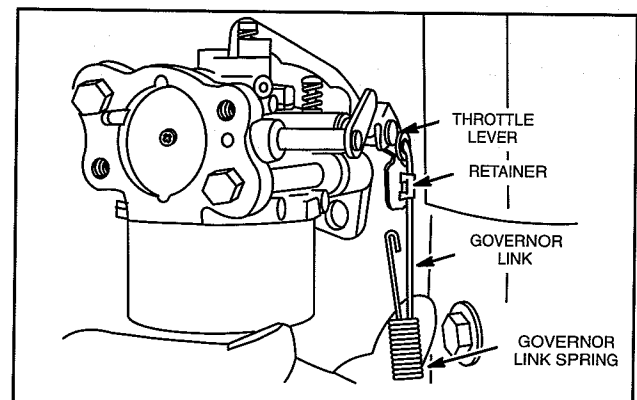

Fig. 62 – Install Governor Link

3. Connect choke link to choke lever and install choke control bracket, Fig. 63.
 - a. Torque screws to 7.0 Nm (65 in. lbs.).
 4. Install air cleaner bracket, if removed.
 5. Install fuel line and clamp.
 6. Install blower housing.
- Install air cleaner base as described below.

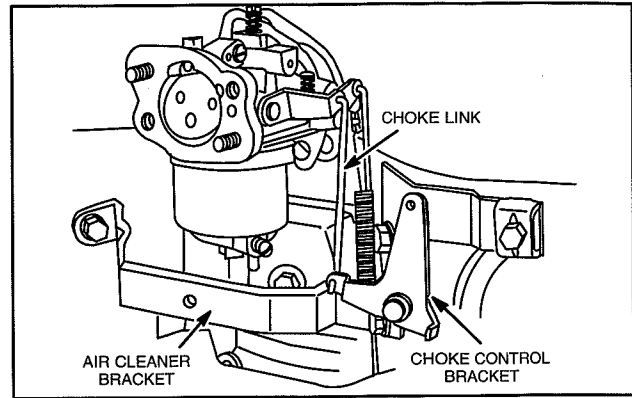

Fig. 63 – Install Choke Control Bracket

**Install Air Cleaner Base –
Vertical Crankshaft Models 290700 – 350700**

Current Style: (Round cartridge) Fig. 64.

1. Install new air cleaner base gasket.
2. Guide breather tube onto nipple on breather and install air cleaner base on carburetor mounting studs.
3. Install carburetor mounting nuts. Do not tighten nuts at this time.
4. Install breather deflector and three screws.
 - a. Torque nuts and screws to 7.0 Nm (65 in. lbs.).

Make sure air inlet tube is installed correctly in air cleaner base.

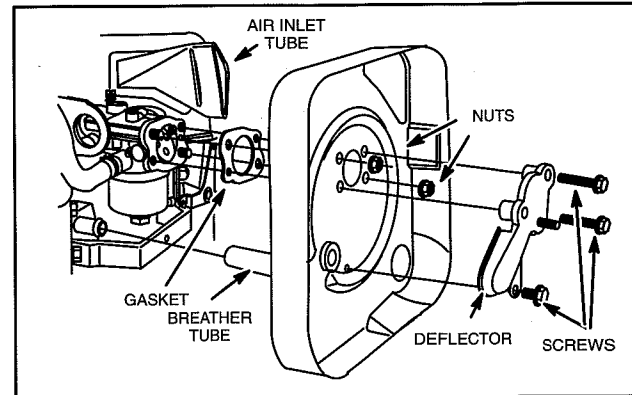

Fig. 64 – Install Air Cleaner Base

Early Style: (Square cartridge) Fig. 65.

1. Insert mounting screws through breather deflector, base and gasket.
2. Guide breather tube onto nipple on breather and install mounting screws in carburetor. Do not tighten screws at this time.
3. Install two air cleaner bracket screws.
 - a. Torque all four screws to 7.0 Nm (65 in. lbs.).

Make sure air inlet tube is installed correctly in air cleaner base.

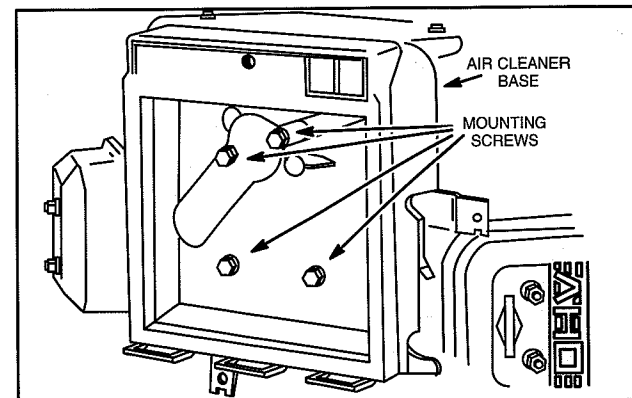

Fig. 65 – Install Air Cleaner Base

**Install Carburetor Vertical Crankshaft
Model 351700 and 380700**

1. Assemble gaskets and spacer to intake manifold.
2. Assemble carburetor onto mounting studs, Fig. 66.
3. Route solenoid wire through wire tie on manifold and through hole in #1 cylinder shield.

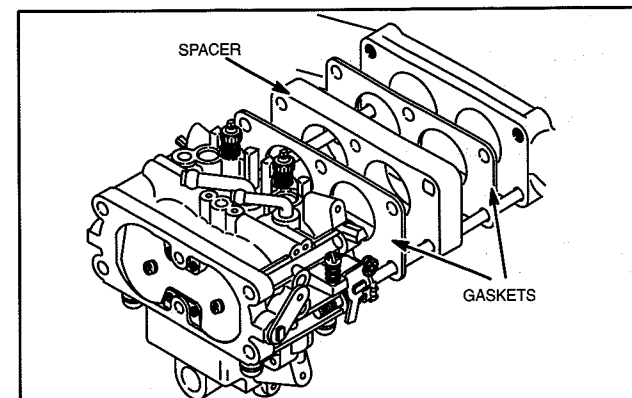

Fig. 66 – Install Carburetor

4. Connect governor link to throttle lever and snap retainer over link, Fig. 67.
5. Install governor link spring in loop on link retainer.

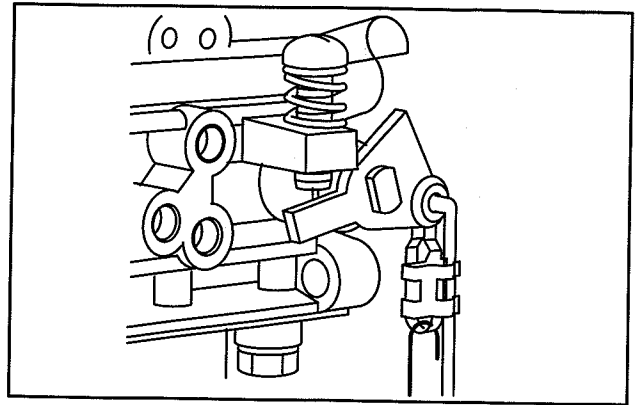

Fig. 67 – Connect Governor Link

6. Connect choke link to choke lever and install choke control bracket, Fig. 68.
 - a. Torque screws to 7.0 Nm (65 in. lbs.)
7. Install fuel line and clamp.
8. Install blower housing.

Install air cleaner base as described below.

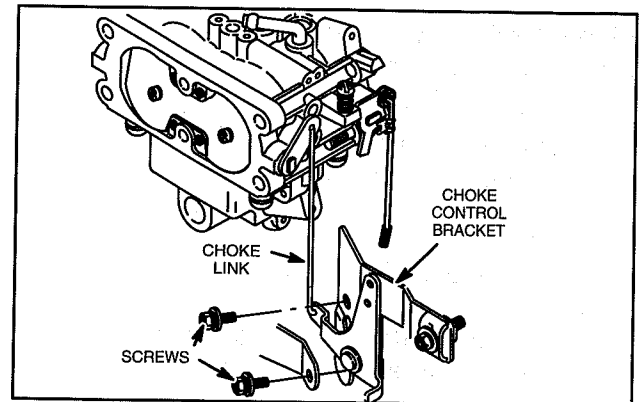

Fig. 68 – Install Choke Control Bracket

Install Air Cleaner Base – Vertical Crankshaft Model 351700 And 380700

1. Install new air cleaner mounting gasket with adhesive side toward air cleaner base, Fig. 69.
2. Guide breather tube onto nipple on breather and install air cleaner base on carburetor mounting studs.
3. Install carburetor shield.
4. Install nuts and screws finger tight.
 - a. Then, torque to 7.0 Nm (65 in. lbs.).

Note: Be sure breather tube is not kinked. Be sure breather tube is installed onto nipple as far as it will go.

Make sure air inlet tube is installed correctly in air cleaner base.

Remove Carburetor And Intake Manifold – Horizontal Crankshaft Models 290400 – 350400

Note All Models: Disconnect anti-afterfire solenoid wire from equipment switch wire. Remove blower housing.

Current style: (Round cartridge)

Remove the following parts, Fig. 70.

1. Air cleaner cover, cartridge and pre-cleaner.
2. Three screws and breather deflector.
3. Two air cleaner base mounting screws.
4. Air cleaner base and breather tube.

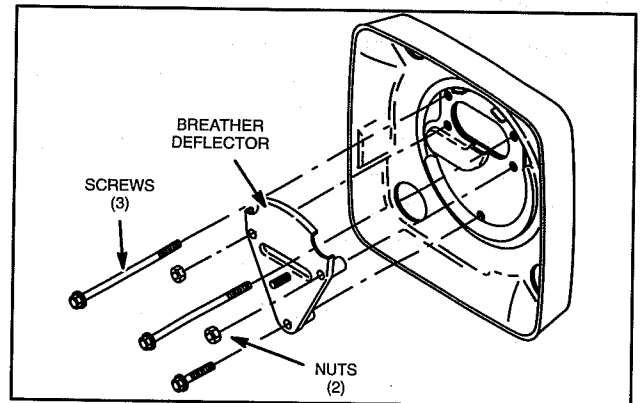

Fig. 69 – Install Air Cleaner Base

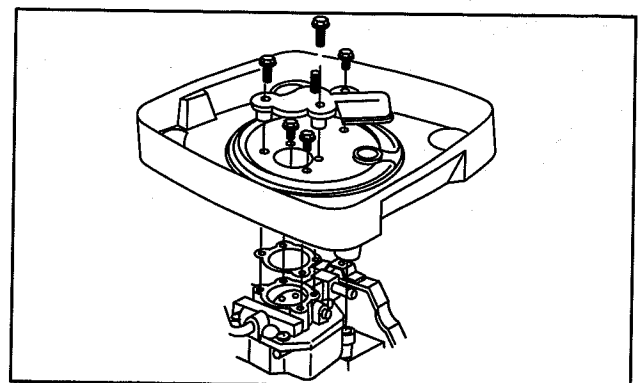

Fig. 70 – Remove Air Cleaner Base

Early style: (Square cartridge)

Remove the following parts, Fig. 71.

1. Air cleaner cover.
2. Four screws.
3. Air cleaner base and breather tube.

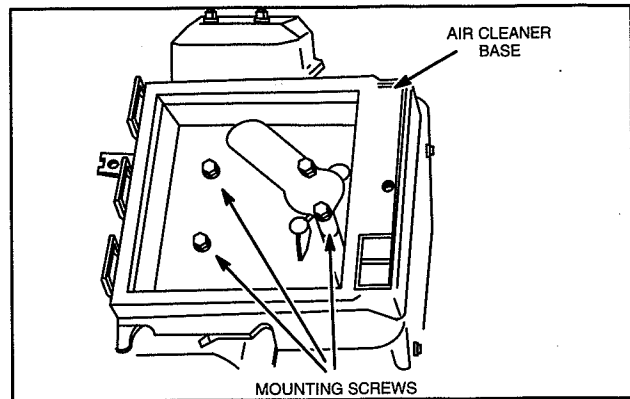

Fig. 71 – Remove Air Cleaner Base

All Models: Fig. 72.

1. Remove two screws and choke control bracket.
2. Disconnect choke link from carburetor.
3. Disconnect fuel line at carburetor.
4. Disconnect governor link spring from throttle lever
5. Disconnect governor link.

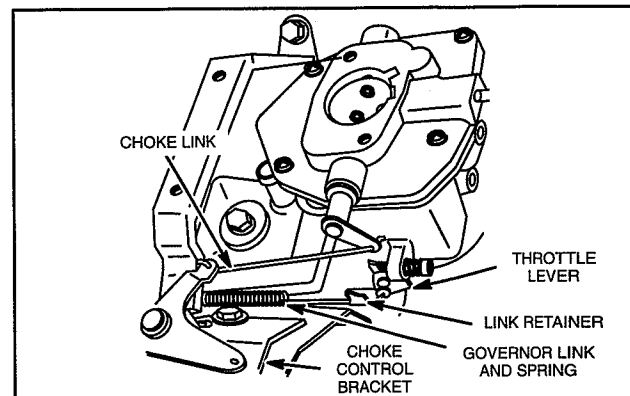

Fig. 72 – Remove Choke Control Bracket

6. Remove intake manifold and gaskets.
7. Remove carburetor, spacer and gaskets, Fig. 73.
 - a. Discard gaskets

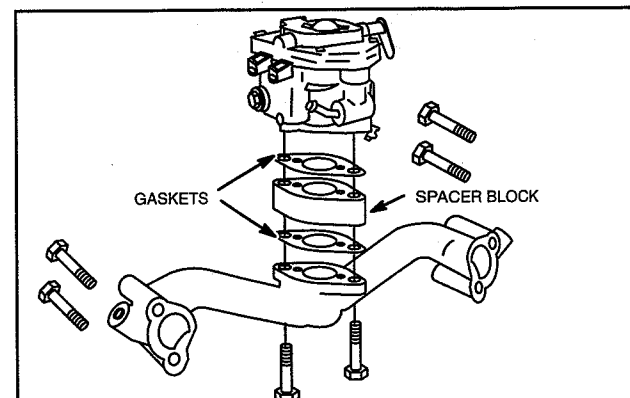

Fig. 73 – Remove Intake Manifold

Remove Carburetor – Horizontal Crankshaft Models 351400 And 380400

The blower housing must be removed so that anti-afterfire solenoid wire can be properly routed during reassembly.

1. Remove air cleaner cover, cartridge and pre-cleaner.
2. Remove five screws and carburetor shield, Fig. 74.
3. Disconnect breather tube at air cleaner base and remove air cleaner base.

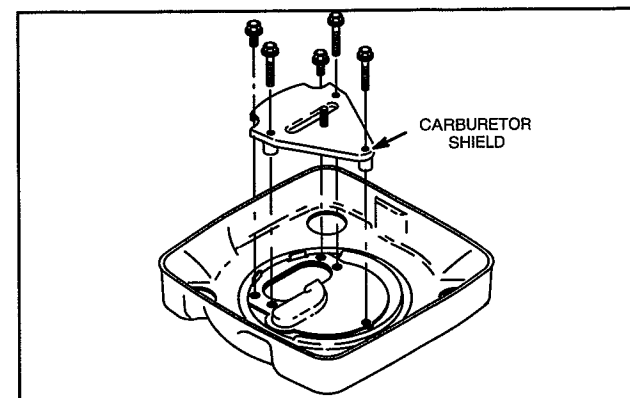

Fig. 74 – Remove Air Cleaner Base

4. Disconnect fuel line at carburetor.
5. Remove anti-afterfire solenoid ground wire.
6. Remove choke control bracket and disconnect link, Fig. 75.

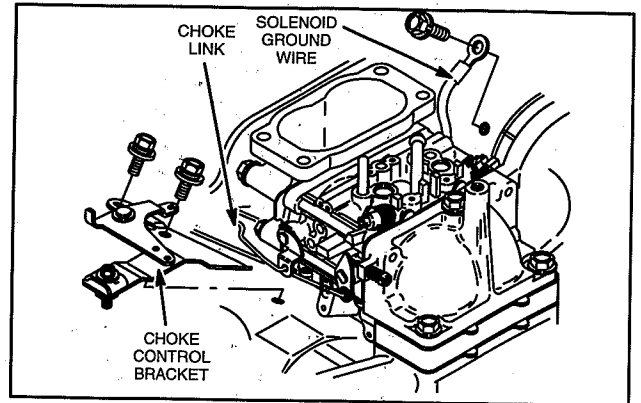

Fig. 75 – Remove Choke Control Bracket

7. Unhook governor link spring from throttle lever and disconnect governor link, Fig. 76.

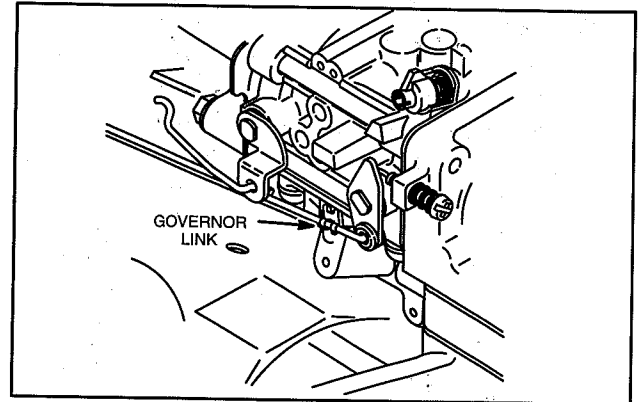

Fig. 76 – Disconnect Governor Link

8. Remove air cleaner elbow support screw.
9. Remove 3 intake elbow screws and carburetor assembly.
10. Remove carburetor spacer and gaskets.

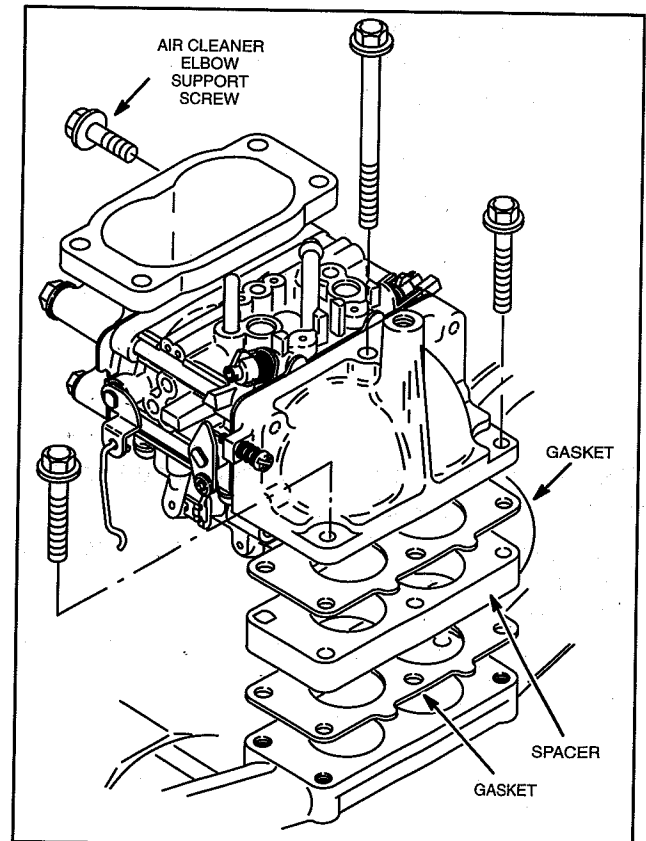

Fig. 77 – Remove Carburetor

11. Remove two nuts and two screws and separate air cleaner elbow and intake elbow from carburetor, Fig. 78.

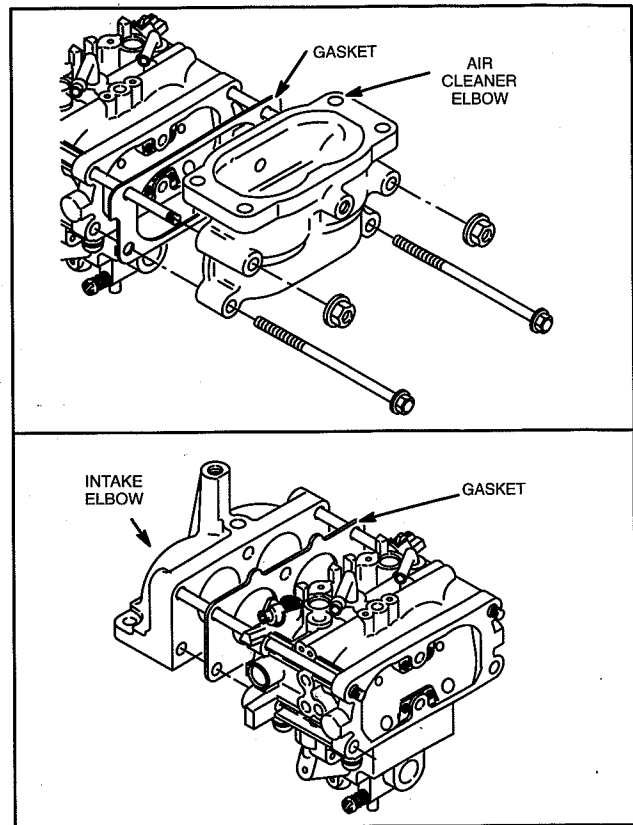

Fig. 78 – Remove Air Cleaner Elbow

**Disassemble Carburetor – Nikki Carburetor
Engine Models 290400-303400
(Model 350400 After 95073100)**

Note: Engine Models 350400: Engines manufactured after code date 95072300 are equipped with a Nikki carburetor.

1. Remove four screws and upper body, Fig. 79.
 - a. Do not damage emulsion tube in upper body.
2. Remove gasket.

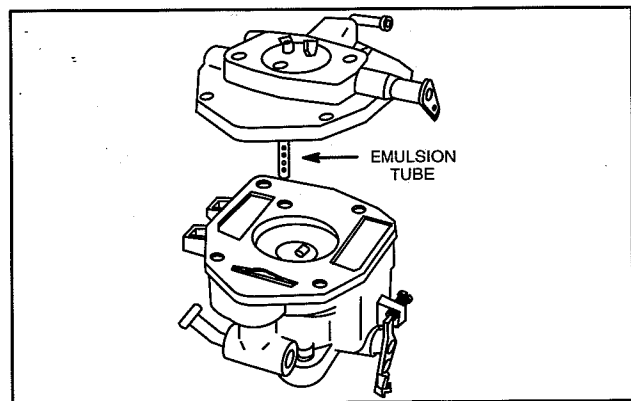

Fig. 79 – Remove Upper Body

3. Remove float and inlet needle, Fig. 80.

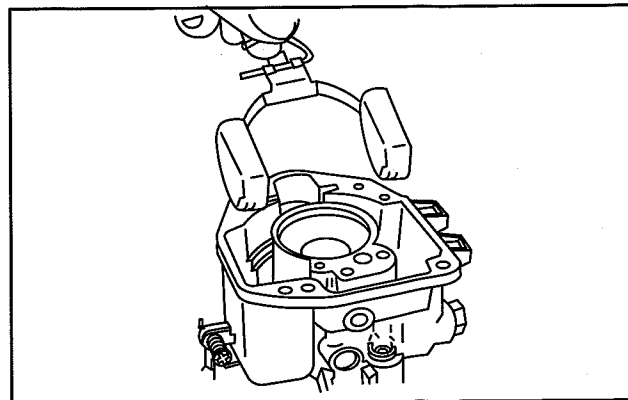

Fig. 80 – Remove Float

If idle mixture screw is equipped with adjustment limiter cap, use a pliers to remove it before removing idle mixture screw.

4. Remove idle mixture screw and spring, Fig. 81.
5. Remove anti-afterfire solenoid, if equipped, or plug and washer.
6. Remove fixed main jet using screwdriver, Tool #19062.

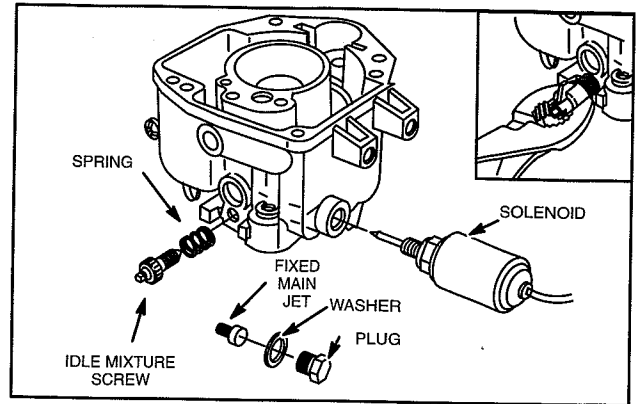

Fig. 81 – Remove Idle Mixture Screw And Main Jet

7. Remove pilot jet using screwdriver, Tool #19061, Fig. 82.

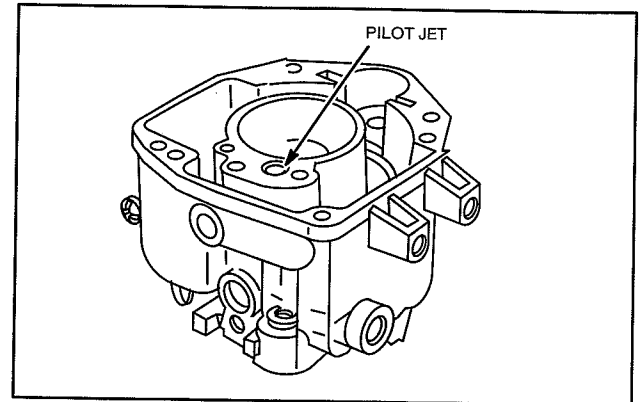

Fig. 82 – Remove Pilot Jet

8. Mark throttle plate before removing so that it may be re-installed in the same position. Top and bottom edges are beveled.
 - a. Remove throttle shaft and spacer, Fig. 83.
 - b. Remove throttle shaft seal.

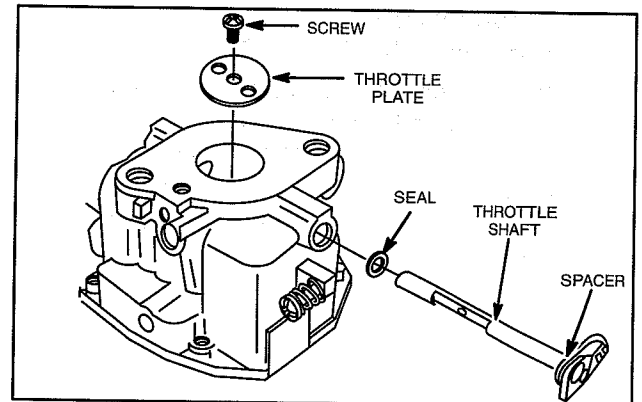

Fig. 83 – Remove Throttle Shaft

Support upper body on a vise or wood block so that emulsion tube will not be damaged.

9. Remove choke shaft and spacer, Fig. 84.
10. Remove seal.

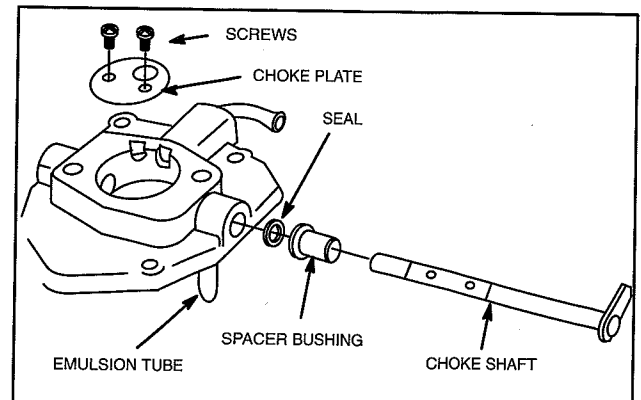

Fig. 84 – Remove Choke Shaft

11. Remove transitional hole welch plug with a punch as shown, Fig. 85.

This completes the carburetor disassembly procedure.

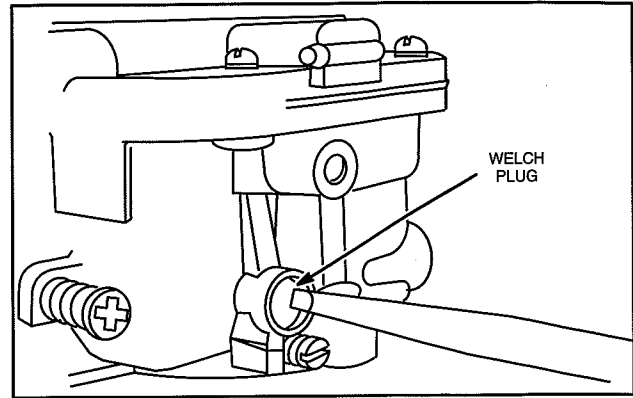

Fig. 85 – Remove Welch Plug

3

Clean Carburetor

Remove gasket material from mounting surfaces. Gummy or dirty carburetors should be cleaned in a commercial carburetor cleaner. DO NOT soak longer than 15 minutes. DO NOT soak rubber, neoprene or plastic parts in commercial carburetor cleaner.

Inspect Carburetor

Inspect all parts for wear, cracks, nicks and burrs. Inspect float for leaks. Replace damaged parts.

Check Throttle, Choke Shaft And Body For Wear

1. Lay carburetor on 6mm (1/4") raised flat surface and check throttle and choke shaft clearance as shown in Fig. 86.

Throttle shaft and choke shaft clearance must not exceed .25 mm (.010").

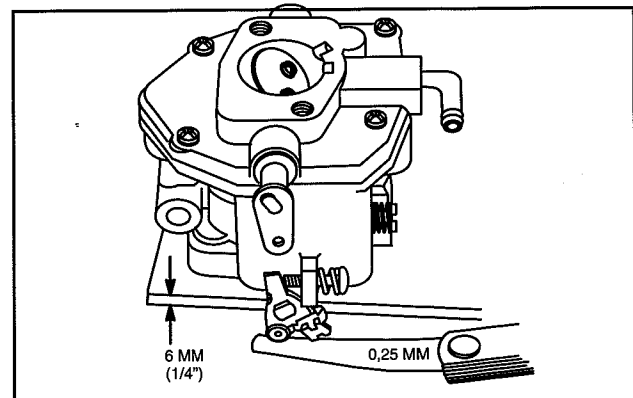

Fig. 86 – Check Clearance

2. Inspect throttle shaft and choke shaft for wear. Replace if worn, Fig. 87.

If carburetor body is worn, replace carburetor.

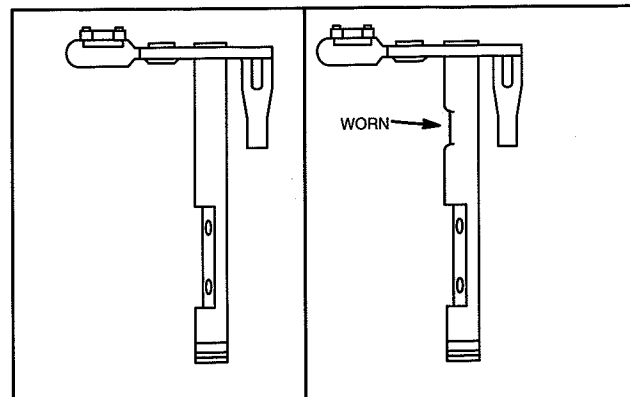

Fig. 87 – Check Throttle And Choke Shaft

**Assemble Carburetor – Nikki Carburetor
Engine Models 290400 – 303400
(Model 350400 After 95073100)**

When assembling carburetor, use new seals and gaskets.

1. Install new transitional hole welch plug, Fig. 88.
2. Use a round punch and tap in plug until it is flat,
3. Use a sealant such as Permatex® #2 or nail polish on outside diameter of plug to prevent air leaks.

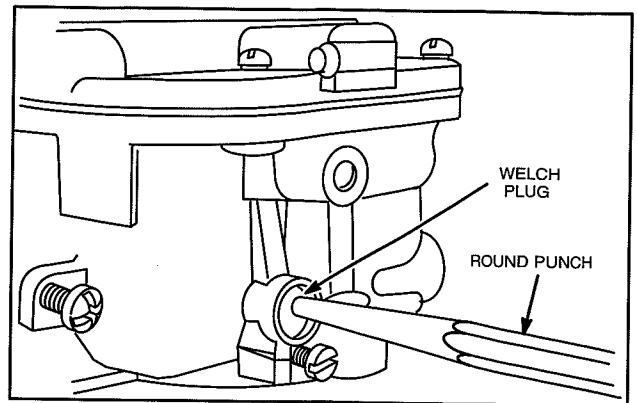

Fig. 88 – Install Welch Plug

4. Install new choke shaft seal with sealing lip in.
5. Install choke shaft and spacer.
6. Install choke plate with vent hole facing bowl vent nipple.

Note: Use LOCTITE® 222 on screw threads.

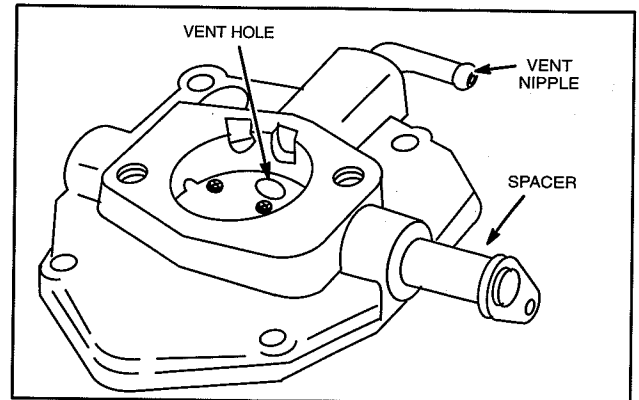

Fig. 89 – Install Choke Shaft

7. Install new throttle shaft seal with sealing lip in.
 8. Install throttle shaft and throttle plate
- Note: Use LOCTITE® 222 on screw threads.**

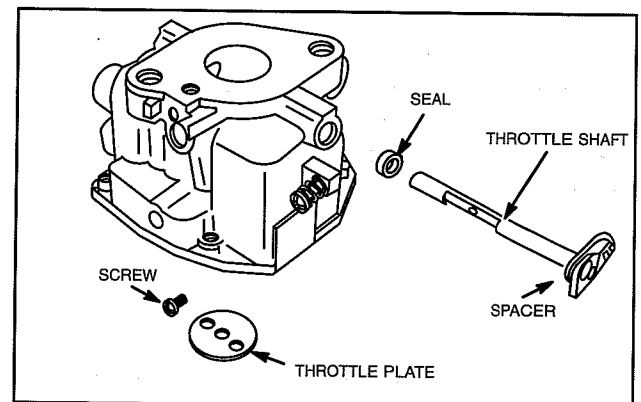

Fig. 90 – Install Throttle Shaft

9. Install pilot jet using screwdriver, Tool #19061, Fig. 91.

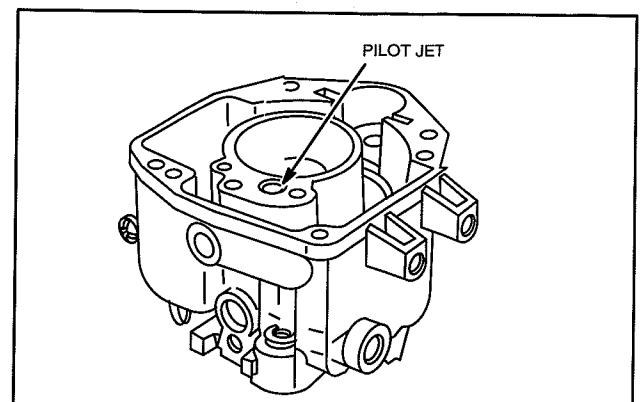

Fig. 91 – Install Pilot Jet

10. Install fixed main jet using screwdriver, Tool #19062.
 11. Install washer and plug or anti-afterfire solenoid.
 - a. Torque to 5.0 Nm (45 in. lbs.).
 12. Install idle mixture screw and spring.
- DO NOT tighten screw.
DO NOT install limiter cap at this time.

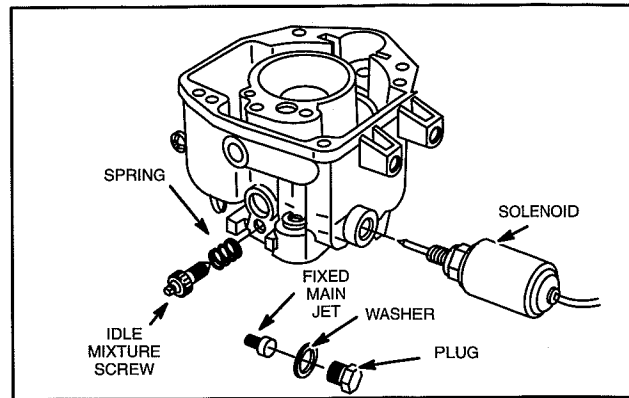

Fig. 92 – Install Idle Mixture Screw And Main Jet

13. Assemble inlet needle to float and install float assembly, Fig. 93.

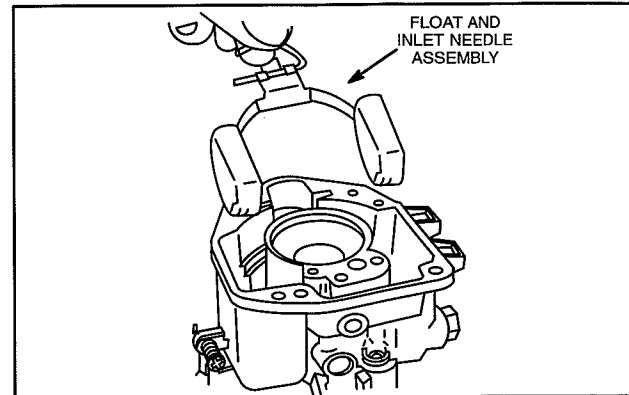

Fig. 93 – Install Float

The fuel inlet seat orifice size and inlet needle are different, depending upon the type of fuel delivery system used. The inlet seat is not replaceable. Therefore, different carburetor bodies are required.

A color code system is used to identify the carburetor by engine model and fuel delivery system. The color code is located on the side of the carburetor as shown in Fig. 94. Then see chart below.

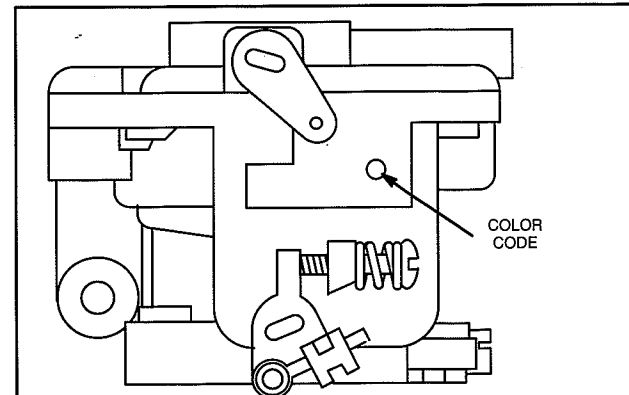

Fig. 94 – Carburetor Identification

| Engine Model | Fuel System | Color Code |
|--------------|-------------|------------|
| 290400 | Gravity | Yellow |
| 290400 | Pump | White |
| 294400 | Gravity | Blue |
| 294400 | Pump | None |
| 303400 | Gravity | Blue |
| 303400 | Pump | None |
| 350400 | Gravity | Blue |
| 303400 | Pump | None |

The float height setting on Nikki carburetors depends upon the the type of fuel delivery system used. A fuel pump system requires a different float height setting than a gravity feed system.

The procedure for checking the float height setting is unique.

1. Hold the carburetor in one hand and place the index finger on the float hinge pin.
2. While holding the float hinge pin down, turn the carburetor to a position **past** vertical as shown in Fig. 95.
3. This allows the weight of the float to close the inlet needle in a natural fashion.
4. The float height measurement, "C" is taken at point "B," which is the top flat area of the float just before the radius.
5. See Fig. 95 for dimensions.

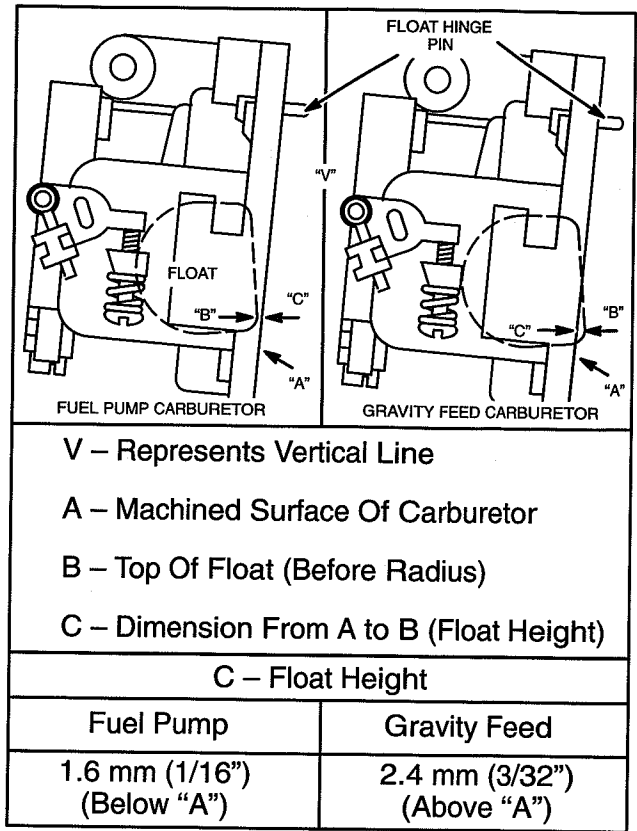

Fig. 95 – Check Float Height

To adjust float level, hold float arm at "A" with needle nose pliers and carefully bend tang in direction shown, Fig. 96. **Do not** collapse hooked end of float tang.

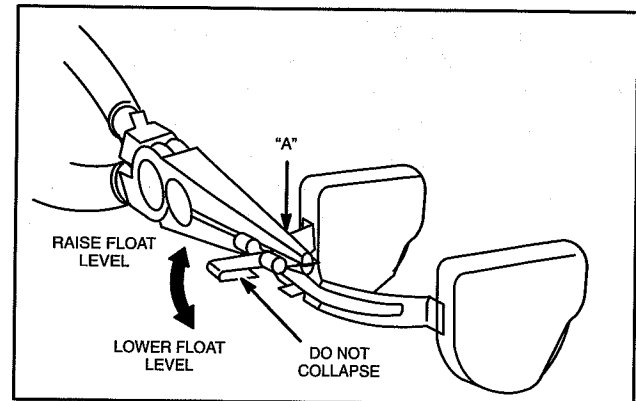

Fig. 96 – Adjust Float Height

1. Place new gasket on lower carburetor body. Make sure holes in body line up with holes in gasket.
2. Install upper carburetor body, Fig. 97.
 - a. Tighten screws securely.

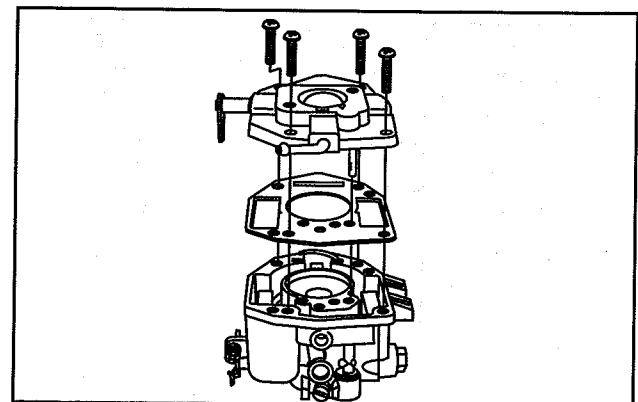

Fig. 97 – Install Upper Body

**Carburetor Identification –
Mikuni Carburetor Engine Model 350400
(Before 95073100)**

Two different carburetor bodies are used, depending upon the type of fuel delivery system; gravity or fuel pump. In addition to a change in jetting, the end of the discharge nozzle is machined at a different angle. The discharge nozzle is an integral part of the carburetor body. Therefore, different bodies are required.

The carburetor bodies may be identified by looking down the carburetor throat and comparing the end of the discharge nozzle in relation to the choke shaft, Fig. 98. On a fuel pump carburetor the end of the nozzle is at approximately a 20 degree angle to the choke shaft. On a gravity feed carburetor the end of the nozzle is approximately parallel to the choke shaft.

The fixed main jet used with a fuel pump system is numbered 110. The fixed main jet used with a gravity system is numbered 117.5.

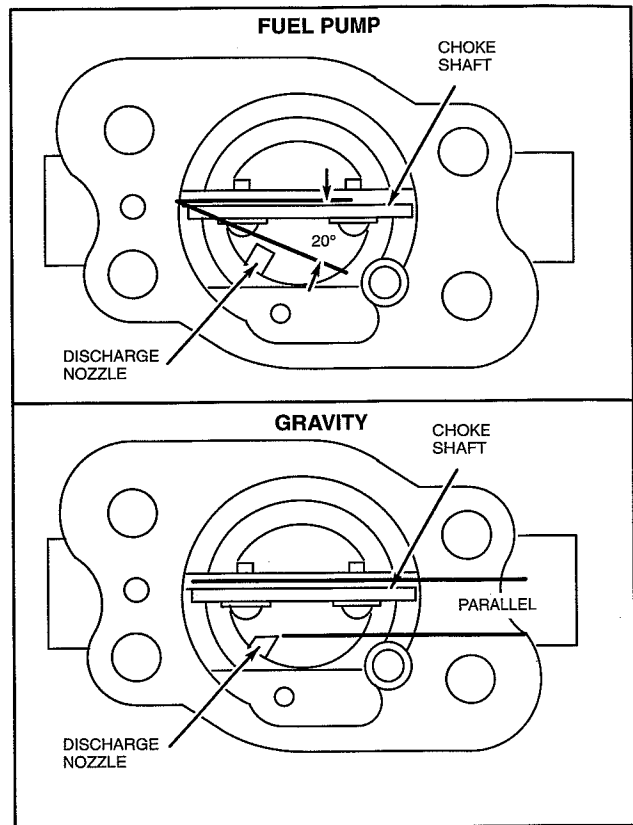

Fig. 98 – Carburetor Identification

3

**Disassemble Carburetor
Mikuni Carburetor – Engine Model 350400
(Before 95073100)**

1. Remove pilot jet.
2. Remove four screws and upper body, Fig. 99.
 - a. Discard gasket.

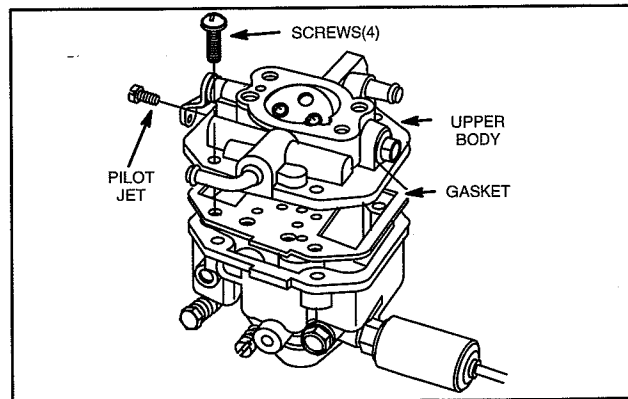

Fig. 99 – Remove Upper Body

3. Remove float and fuel inlet needle, Fig. 100.

Note: **Float hinge** pin is swaged on one end. Drive hinge pin out from side opposite swage.

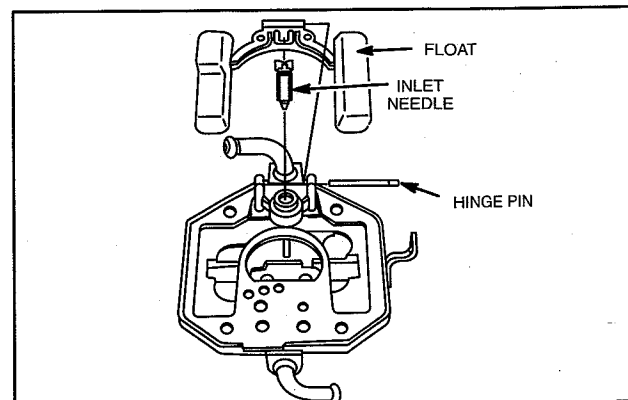

Fig. 100 – Remove Float

4. Remove anti-afterfire solenoid or plug.
5. Remove fixed jet plug and washer.
6. Remove fixed main jet with jet screwdriver, Tool #19062, Fig. 101.
7. Remove emulsion tube.

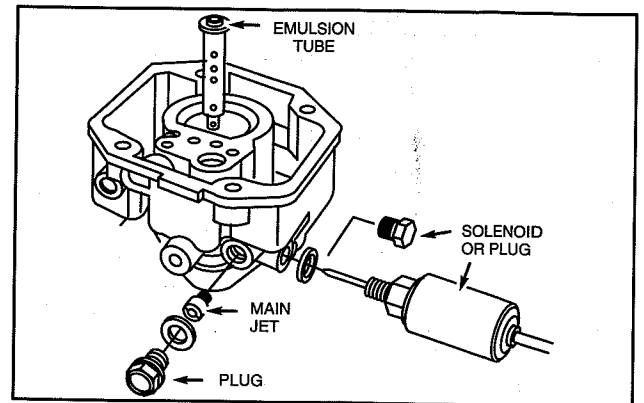

Fig. 101 - Remove Main Jet

If idle mixture screw is equipped with adjustment limiter cap, use a pliers to remove it before removing idle mixture screw.

8. Remove idle mixture screw and spring, Fig. 102.
9. Remove fuel bowl drain screw and spring.

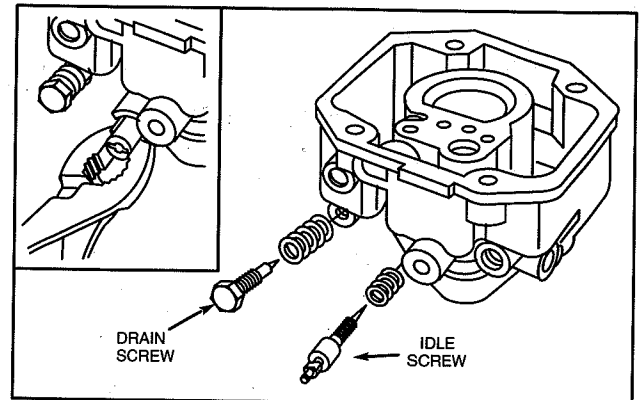

Fig. 102 - Remove Idle Mixture Screw

10. Mark throttle plate before removing so that it may be re-installed in the same position. Top and bottom edges are beveled.
 - a. Remove retainer.
 - b. Remove throttle shaft with foam seals and spacer, Fig. 103.
 - c. Remove seals.

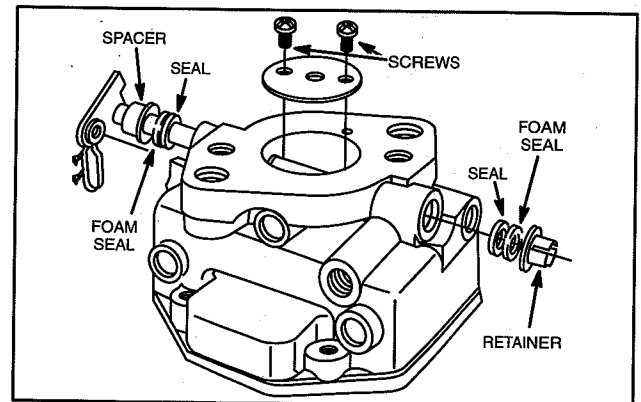

Fig. 103 - Remove Throttle Shaft

11. Mark choke plate before removing so that it may be re-installed in the same position. Top and bottom edges are beveled.
 - a. Remove retainer.
 - b. Remove choke shaft and spacer.
 - c. Remove seals.

Note: Carburetor body has a ball and spring that keeps tension on choke shaft. Use care when removing choke shaft.

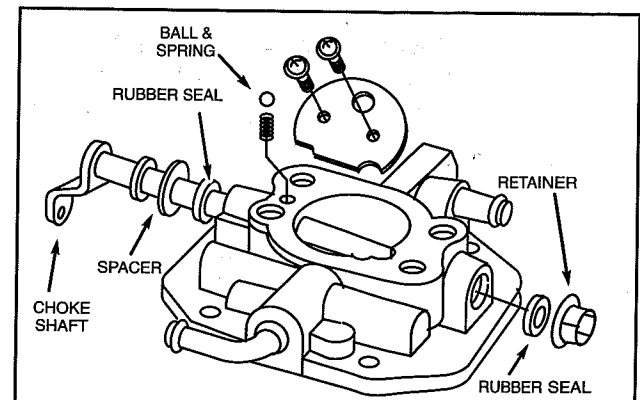

Fig. 104 - Remove Choke Shaft

Remove Fuel Inlet Body And Seat

The fuel inlet body must be removed before the inlet seat can be removed.

1. Use self-threading screw #93029 from flywheel puller, Tool #19165. Thread screw into seat body 3-4 turns. Then, remove the screw, Fig. 105.

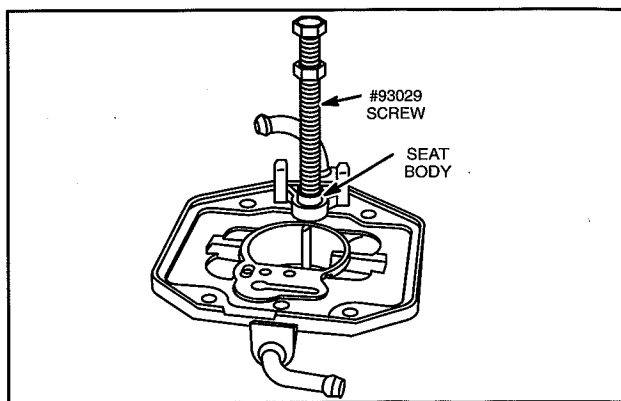

Fig. 105 – Remove Inlet Body

2. Install 1/4" x 20 nut #92278 and washer #224061 from 19332 Tool Kit onto screw.
3. Place a 1/4" drive 9 mm (3/8") socket over seat body.
4. Install screw, washer and nut. Thread nut down on washer.
5. Continue turning until seat body is removed, Fig. 106.
 - a. Remove fuel inlet seat.

This completes the carburetor disassembly procedure.

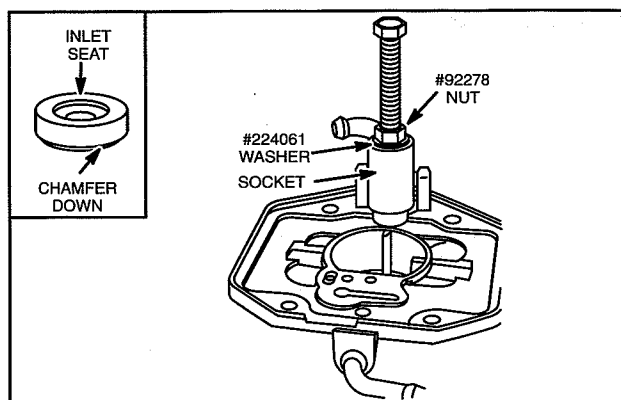

Fig. 106 – Remove Inlet Seat

Clean Carburetor

Remove gasket material from mounting surfaces. Gummy or dirty carburetors should be cleaned in a commercial carburetor cleaner. DO NOT soak longer than 15 minutes. DO NOT soak rubber, neoprene or plastic parts in carburetor cleaner.

Inspect Carburetor

Inspect all parts for wear, cracks, nicks and burrs. Inspect float for leaks. Replace damaged parts.

Check Throttle, Choke Shaft And Body For Wear

1. Lay carburetor on 3mm (1/8") raised flat surface and check throttle and choke shaft clearance as shown in Fig. 107.

Throttle shaft and choke shaft clearance must not exceed .25 mm (.010").

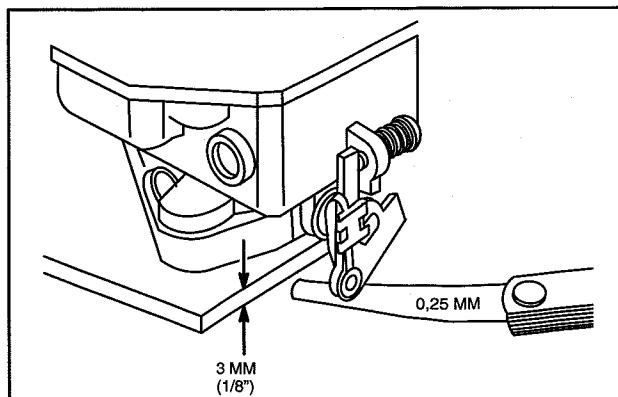

Fig. 107

2. Inspect throttle shaft and choke shaft for wear.
Replace if worn, Fig. 108.
- If carburetor body is worn, replace carburetor.

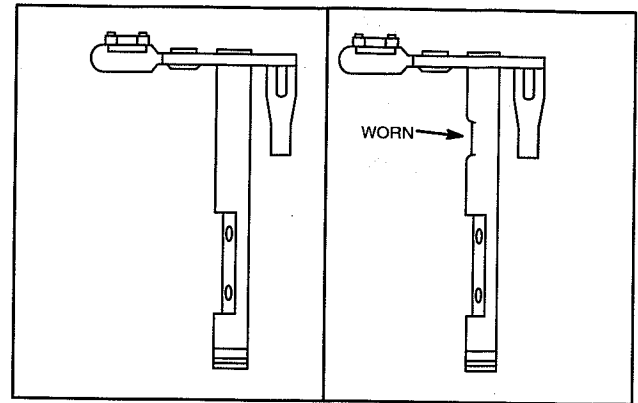

Fig. 108 – Check Throttle And Choke Shaft

Assemble Carburetor – Mikuni Carburetor Engine Model 350400 (Before 95073100)

When assembling carburetor, use new seals and gaskets.

Install Fuel Inlet Seat And Body

1. Install new inlet seat with chamfered end down, Fig. 109.
2. Press in new body using Tool #19135.

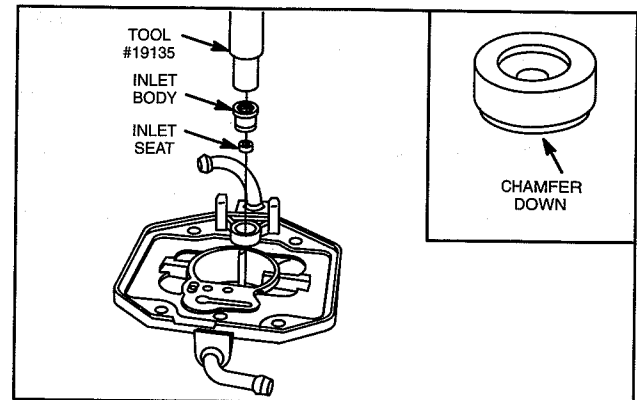

Fig. 109 – Install Inlet Seat And Body

3. Install new throttle shaft seals with sealing lip out.
 4. Install throttle shaft with spacer and foam seal.
 5. Install foam seal and retainer, Fig. 110.
 6. Install throttle plate.
- Note:** Use **LOCTITE® 222** on screw threads.

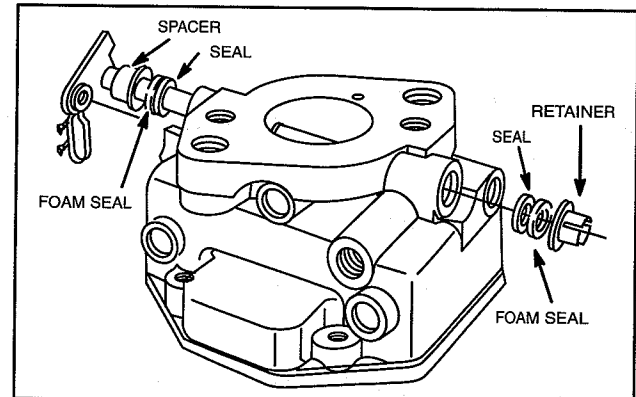

Fig. 110 – Install Throttle Shaft

7. Install new choke shaft seals with sealing lip out.
8. Assemble spacer onto choke shaft.
9. Insert spring and check ball in to spring pocket and compress with a small round punch.
10. Push choke shaft into hole until ball engages groove in choke shaft, Fig. 111.
11. Install choke plate.

Note: Use **LOCTITE® 222** on screw threads.

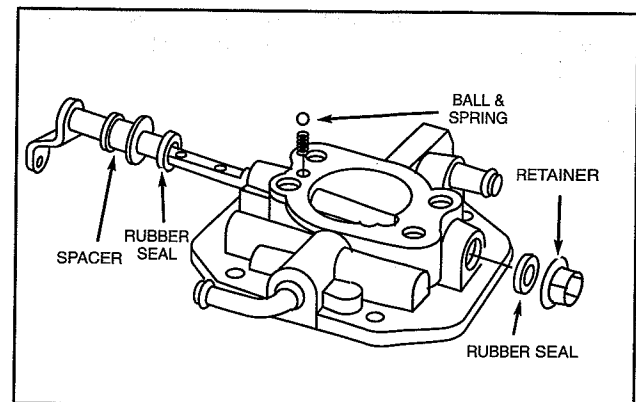

Fig. 111 – Install Choke Shaft

12. Install fixed main jet with jet screwdriver, Tool #19062, Fig. 112.
13. Install washer and plug.
14. Install emulsion tube.

Note: Fixed main jets are numbered for the type of fuel delivery system used. Install #110 jet if engine is equipped with a fuel pump. Install #117.5 jet if engine is equipped with a gravity fuel tank.

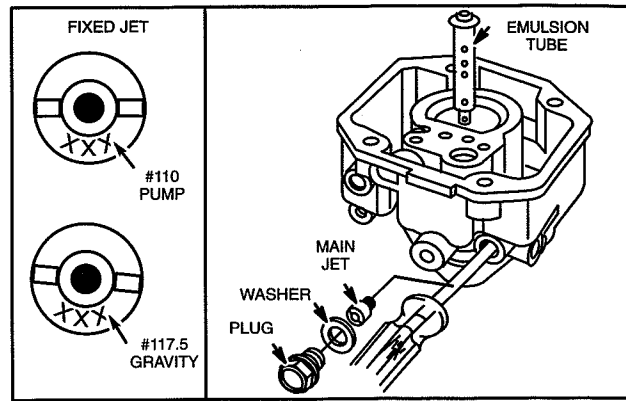

Fig. 112 – Install Main Jet

15. Install bowl drain screw and spring.
 16. Install idle mixture screw and spring.
- DO NOT tighten valves.
DO NOT install limiter cap at this time.

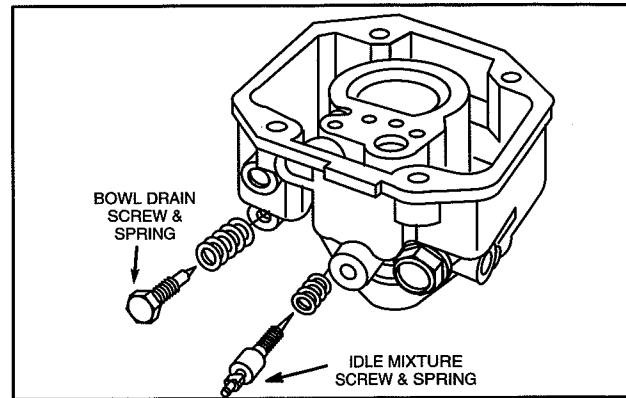

Fig. 113 – Install Idle Mixture Screw

17. Assemble inlet needle retainer to inlet needle and assemble to float, Fig. 114.
18. Install float.

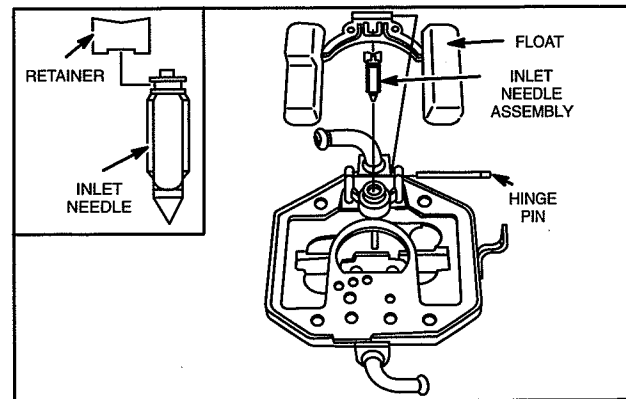

Fig. 114 – Install Float

19. Hold carburetor upper body upside-down as shown in Fig. 115.
 - a. The float should be parallel with carburetor bowl mounting surface.
 - b. If not, use a small screw driver and bend tang as shown.
- DO NOT press on float to adjust.

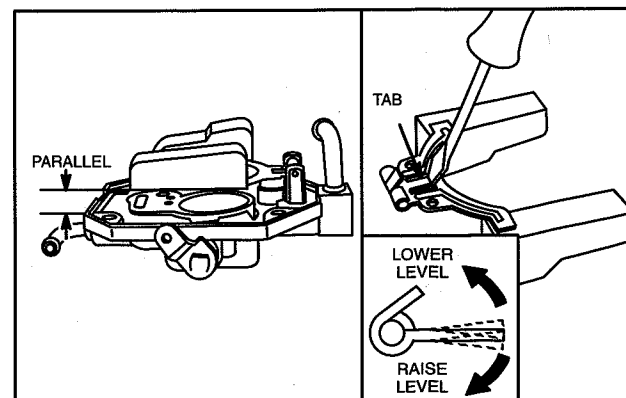

Fig. 115 – Check Float Level

20. Place new gasket on lower carburetor body. Make sure holes in body line up with holes in gasket.
21. Install upper carburetor body, Fig. 116.
 - a. Tighten screws securely.
22. Install pilot jet.
23. Install washer and plug or anti-afterfire solenoid.
 - a. Torque to 5.0 Nm (45 in. lbs.).

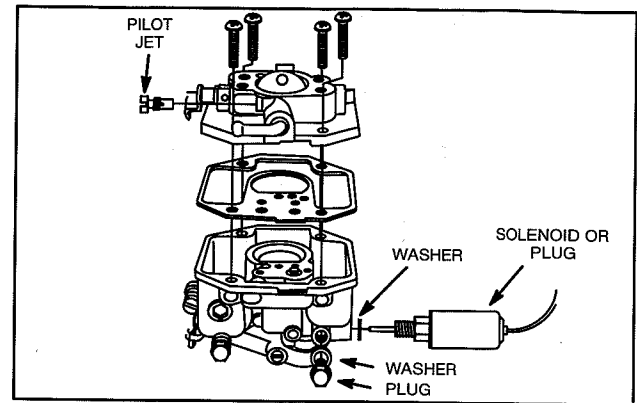

Fig. 116 – Install Upper Body

Install Carburetor And Intake Manifold – Horizontal Crankshaft Models 290400 – 350400

1. Assemble gaskets, spacer and carburetor to intake manifold, Fig. 117.
 - a. Be sure locating pin in spacer fits in recess in manifold.
 - b. Torque screws to 7.0 Nm (65 in. lbs.).

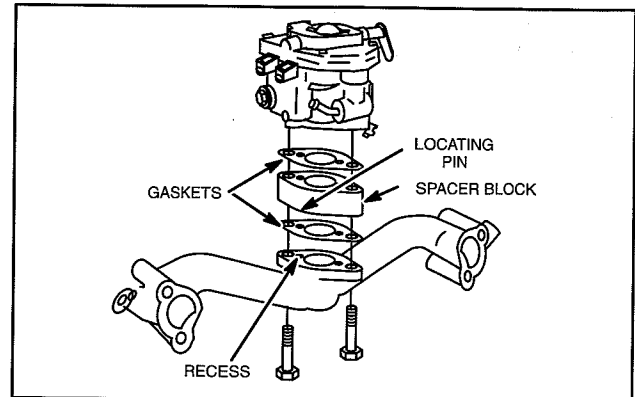

Fig. 117 – Install Carburetor

2. Install carburetor and manifold assembly to cylinder heads, Fig. 118.
 - a. Torque screws to 16.0 Nm (140 in. lbs.).

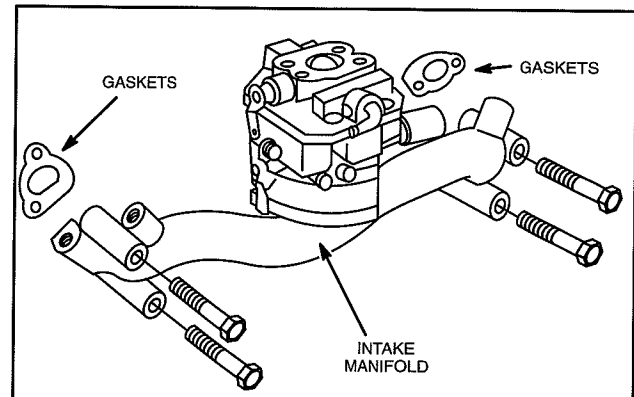

Fig. 118 – Install Intake Manifold

3. Connect governor link to throttle lever and snap retainer over link.
4. Install governor link spring in loop on retainer.
5. Assemble choke link to carburetor and choke lever and install choke bracket.
 - a. Torque screws to 7.0 Nm (65 in. lbs.).
6. Install fuel line and clamp.

Note: If carburetor is equipped with anti-afterfire solenoid, route wire under intake manifold and through hole in #1 cylinder shield at this time.

Install blower housing on engine. Install air cleaner base and air cleaner assembly as described below.

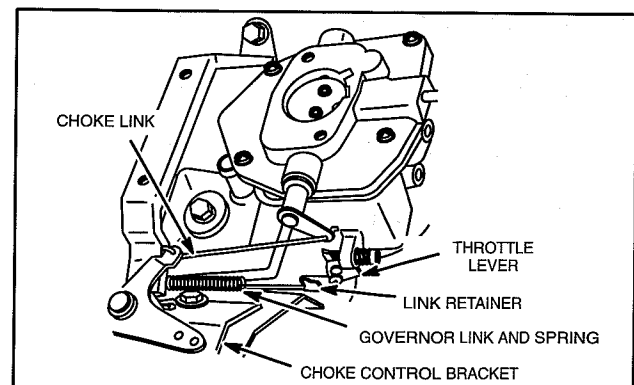

Fig. 119 – Connect Governor Link

**Install Air Cleaner Base –
Horizontal Crankshaft
Models 290400 – 350400**

Current Style: (Round cartridge)

1. Install new air cleaner base gasket.
2. Guide breather tube onto nipple on breather and install air cleaner base on carburetor and support bracket.
3. Install two air cleaner base screws. Do not tighten at this time, Fig. 120.
4. Install breather deflector and three screws.
 - a. Torque screws to 7.0 Nm (65 in. lbs.).

Make sure air inlet tube is installed correctly in air cleaner base.

Early Style: (Square cartridge)

1. Install new air cleaner base gasket.
2. Guide breather tube onto nipple on breather and install air cleaner base on carburetor and support bracket.
3. Install breather deflector and two screws. Do not tighten at this time.
4. Install two air cleaner support screws, Fig. 121.
 - a. Torque screws to 7.0 Nm (65 in. lbs.).

Make sure air inlet tube is installed correctly in air cleaner base.

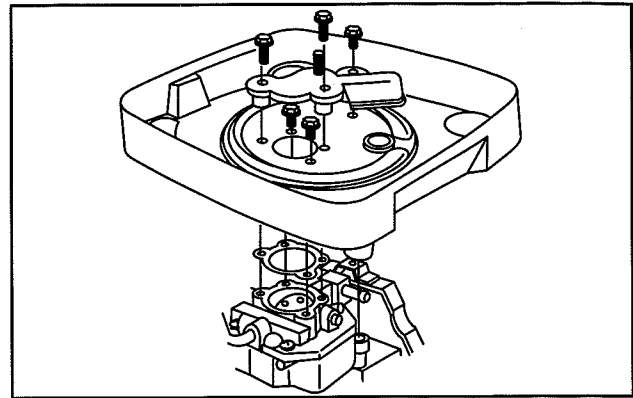

Fig. 120 – Install Air Cleaner Base

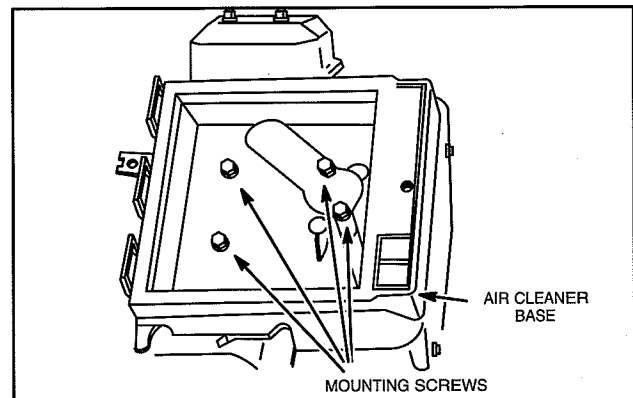

Fig. 122 – Install Air Cleaner Base

**Install Carburetor Horizontal Crankshaft
Model 351400 And 380400**

1. Assemble intake elbow and air cleaner elbow to carburetor with new gaskets.
2. Install air cleaner elbow gasket with adhesive side toward air cleaner elbow and arrow up, Fig. 123.

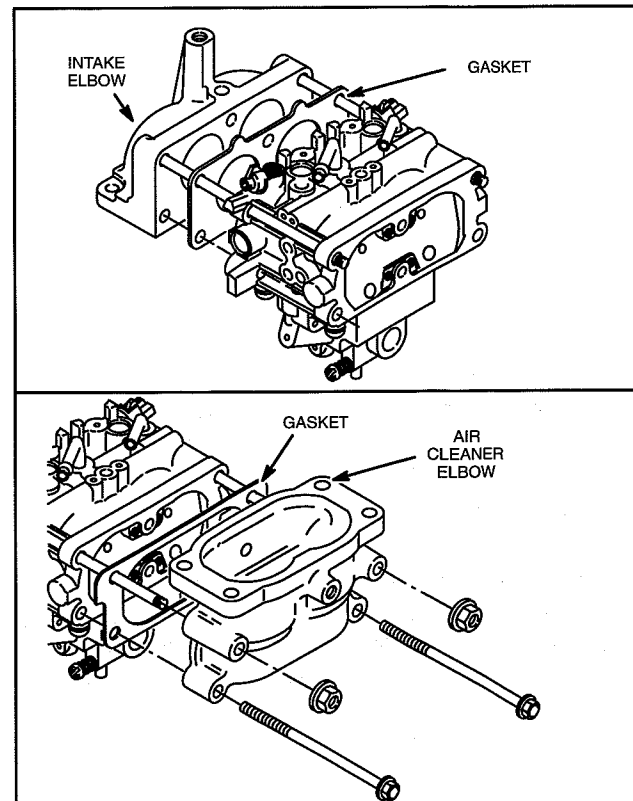

Fig. 123 – Install Intake And Air Cleaner Elbow

3. Assemble choke link to choke lever.
4. Assemble carburetor, gasket, spacer and gasket to intake manifold, Fig. 124.
5. Route both solenoid wires through hole in intake manifold.
 - a. Torque three screws to 7.0 Nm (65 in. lbs.).

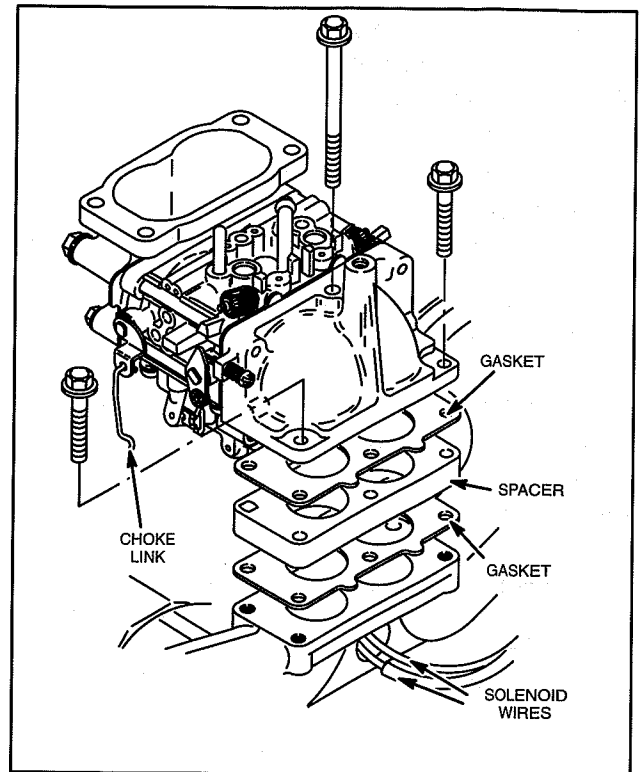

Fig. 124 - Assemble Carburetor To Intake Elbow

6. Install solenoid ground wire.
 - a. Torque screw to 7.0 Nm (65 in. lbs.).
7. Route long solenoid wire under wire tie on manifold, then through hole in #1 cylinder shield.

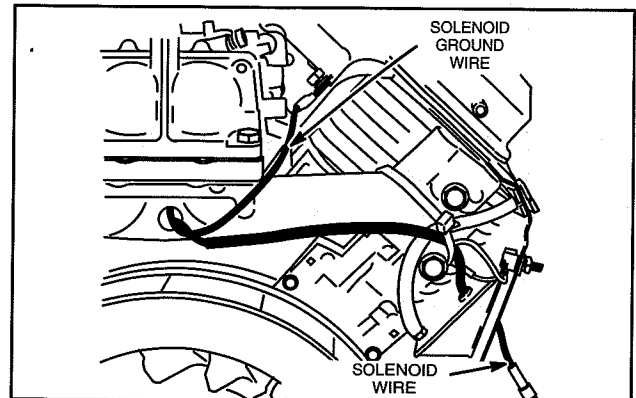

Fig. 125 - Route Solenoid Wire

8. Connect governor link to throttle lever and snap retainer over link.
9. Install governor link spring in loop on retainer.
10. Assemble choke link to carburetor and choke lever and install choke bracket.
 - a. Torque screws to 7.0 Nm (65 in. lbs.).
11. Install air cleaner elbow support.
 - a. Torque screw to 7.0 Nm (65 in. lbs.).

Install blower housing, rotating screen and fuel pump assembly. Install fuel line at carburetor. Rotate fuel line clamp tabs horizontally to prevent interference with air cleaner base.

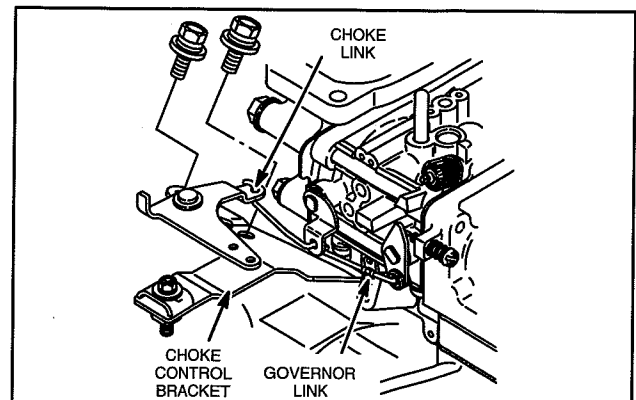

Fig. 126 - Connect Governor Link

**Install Air Cleaner Base –
Horizontal Crankshaft Model 351400**

1. Install new air cleaner mounting gasket with adhesive side toward air cleaner base.
2. Connect breather tube to air cleaner base and assemble air cleaner base to air cleaner elbow.
3. Install carburetor shield and five screws finger tight.
 - a. Then torque screws to 7.0 Nm (65 in. lbs.).
4. Make sure air inlet tube is installed correctly in air cleaner base.

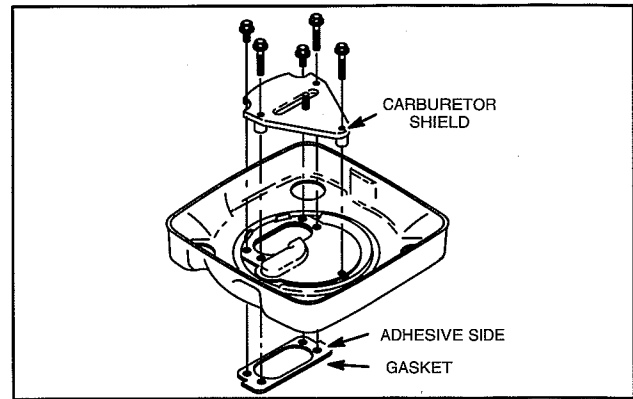

Fig. 127 – Install Air Cleaner Base

⚠ WARNING: WHENEVER CARBURETOR AND MANIFOLD ARE REMOVED, STATIC GOVERNOR ADJUSTMENT SHOULD BE CHECKED! MISADJUSTMENT COULD RESULT IN ENGINE OVERSPEEDING WHICH COULD CAUSE ENGINE DAMAGE, PROPERTY DAMAGE OR PERSONAL INJURY.

ALL MODELS

STATIC GOVERNOR ADJUSTMENT (Before Running Engine)

1. Loosen governor lever nut. Push on governor lever until throttle is wide open. **Do not bend governor link or distort governor lever.**
2. Rotate governor shaft counter-clockwise as far it will go, Fig. 128.
 - a. Torque governor nut to 8.0 Nm (70 in. lbs.).
3. Install throttle and choke control cables and check for proper operation.

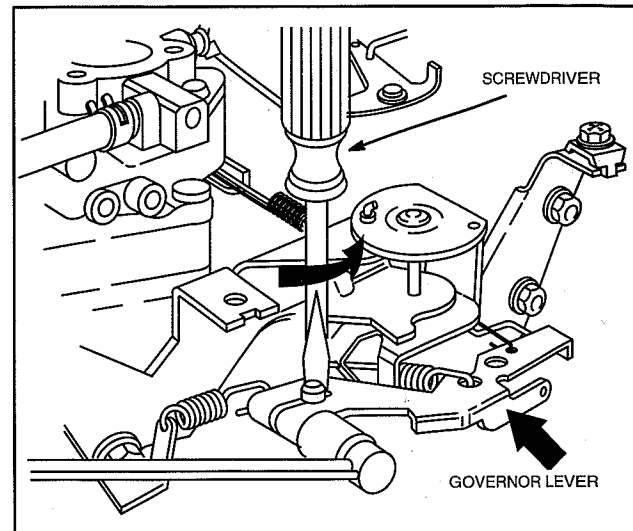

Fig. 128 – Static Governor Adjustment

**Carburetor Adjustment
Engine Models 290000 – 350000**

The Vanguard ohv twin cylinder engine carburetor fuel mixture adjustment procedure is unique. Perform adjustments exactly in the sequence shown.

**Initial Adjustment –
Engine Models 290000 – 350000**

1. Turn idle mixture screw clockwise until it just seats. **DO NOT FORCE.**
2. Turn valve counter-clockwise 1-1/4 turns.

This setting will permit engine to start. Final adjustment will be made with engine running.

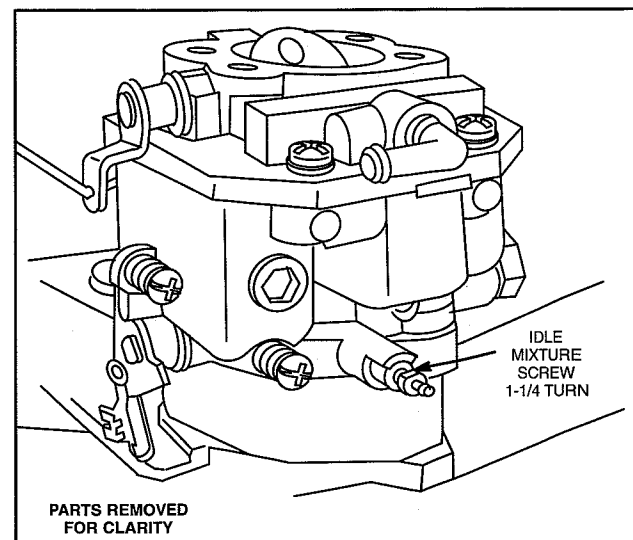

Fig. 129 – Initial Adjustment

If engine is equipped with a secondary governor spring as shown in Fig. 130, check governor lever adjustment procedure before starting engine. See Adjust Secondary Governor Spring, Section 4.

Final Adjustment – Engine Models 290000 – 350000

All carburetor adjustments with engine running must be made with the air cleaner installed as done at the factory.

Note: If engine is equipped with Performance Control™ electronic governor see separate adjustment procedure.

The following tools are required when making carburetor adjustments, Fig. 131.

1. An accurate tachometer, such as Tool #19200 or #19389.
2. Tang bender, Tool #19352.

Start and run engine for approximately 5 minutes to allow engine to warm up.

1. Move control lever on equipment to SLOW position.
2. Hold throttle lever against idle speed screw and temporarily adjust idle (Fig. 132) to RPM shown below.
 - a. 1400 RPM – Governed idle spring Part #805453 (red).
 - b. 1100 RPM – Governed idle spring Part #805454 (white).
3. Turn idle mixture screw slowly clockwise until engine speed just starts to slow (lean mixture).
4. Then turn idle mixture screw counterclockwise until engine speed just starts to slow (rich mixture).
5. Turn screw to mid point between rich and lean, Fig. 133.

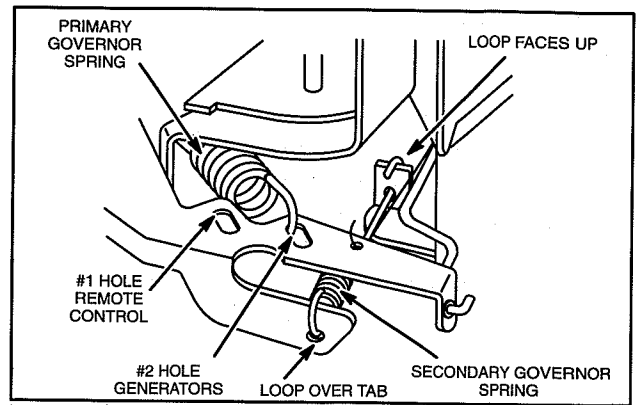

Fig. 130 – Secondary Governor Spring

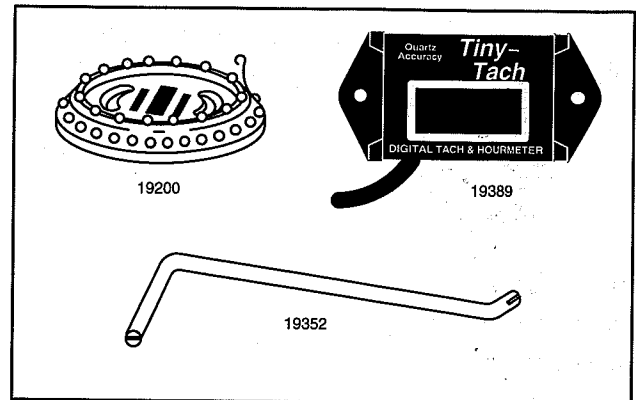

Fig. 131 – Adjustment Tools

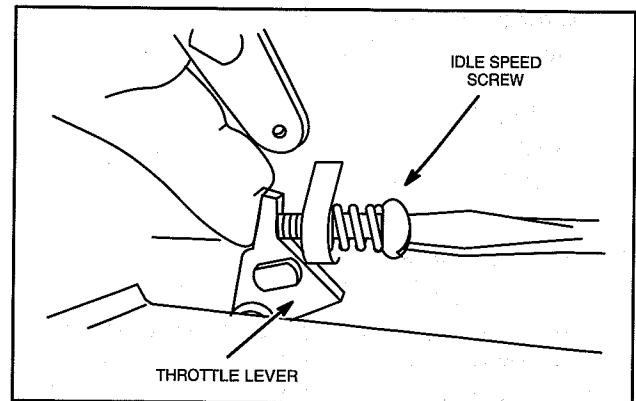

Fig. 132 – Adjust Idle Speed

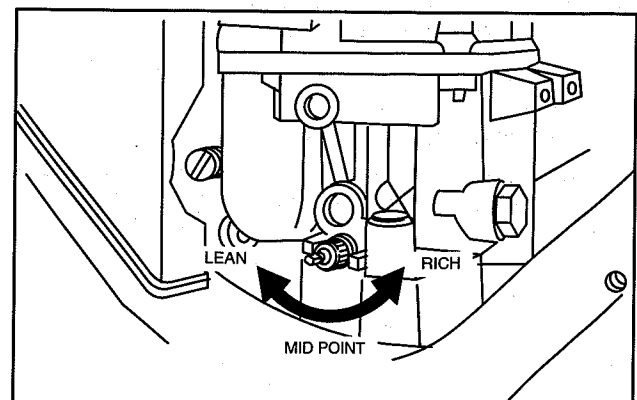

Fig. 133 – Adjust Idle Mixture

6. Hold throttle lever against idle speed adjustment screw and readjust idle to RPM shown below:
 - a. 1200 RPM – Governed idle spring Part #805453 (red).
 - b. 900 RPM – Governed idle spring Part #805454 (white).
7. Release throttle lever. Note RPM.
8. If necessary, use tang bending Tool, #19352, and bend governed idle tang, Fig. 134 to obtain RPM shown:
 - a. 1750 RPM – Governed idle spring Part #805453 (red).
 - b. 1100 RPM – Governed idle spring Part #805454 (white).
9. **IF CARBURETOR IS EQUIPPED WITH AN IDLE MIXTURE LIMITER CAP, INSTALL AT THIS TIME.**
 - a. Position limiter cap so that stop(s) on limiter cap are at mid point between stop(s) on carburetor body.
 - b. Press limiter into position using knock out pin, Tool #19135 as shown in, Fig. 135.

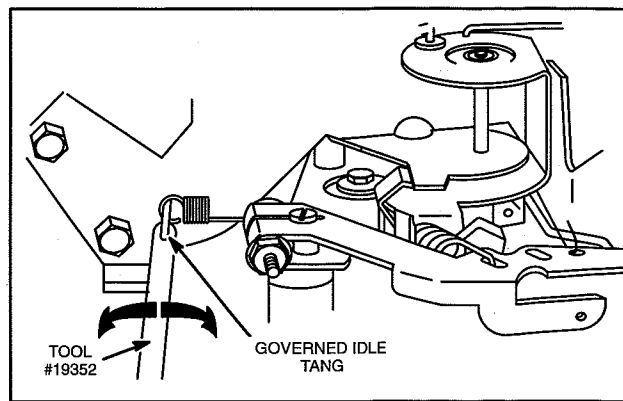

Fig. 134 – Adjust Governed Idle

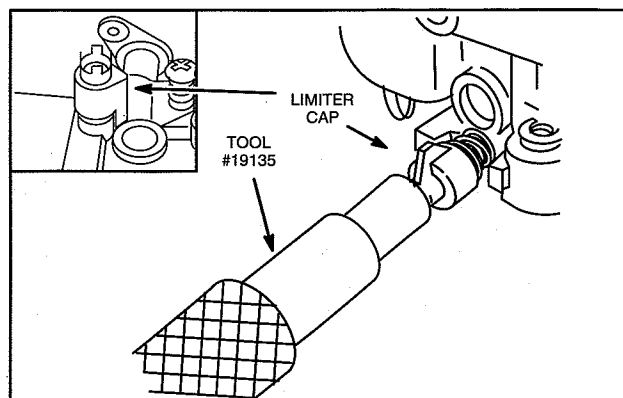

Fig. 135 – Install Limiter Cap

10. With equipment control lever in SLOW position and engine running at governed idle RPM, use tang bender, Tool #19352, and bend throttle restrictor tang so that tang just contacts governor lever, Fig. 136.
11. Move equipment control to FAST position. Engine should accelerate smoothly.
 - a. Readjust idle mixture valve 1/8 turn richer if necessary.

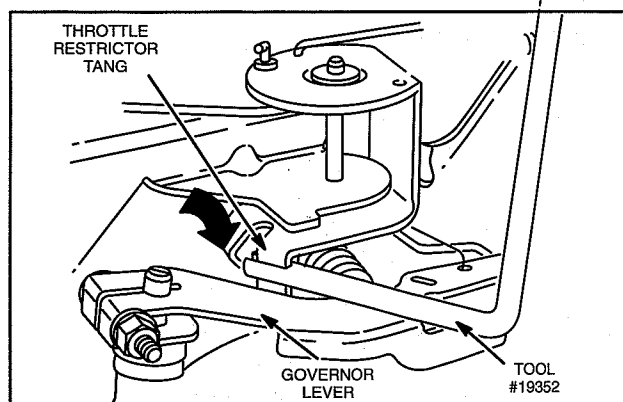

Fig. 136 – Adjust Throttle Restrictor

Final Adjustment – Engines Equipped With Performance Control™ Electronic Governor

All carburetor adjustments with engine running must be made with the air cleaner installed as done at the factory.

1. Start engine and run it for approximately 5 minutes to allow engine to reach operating temperature.
2. Activate idle down device, or ground BLUE wire from control module using a jumper wire, Fig. 137.
3. Temporarily adjust idle speed to 1400 RPM.

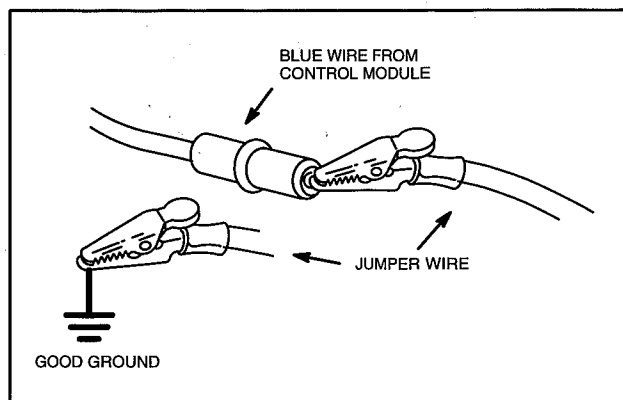

Fig. 137 – Electronic Governor – Idle Circuit

4. Turn idle mixture screw slowly clockwise until engine speed just starts to slow (lean mixture).
5. Then turn idle mixture valve counterclockwise until engine speed just starts to slow (rich mixture).
6. Turn valve to mid point between rich and lean, Fig. 138.
7. Re-adjust idle speed to 1750 RPM.

Note: Idle speed may vary according to equipment manufacturers specifications.

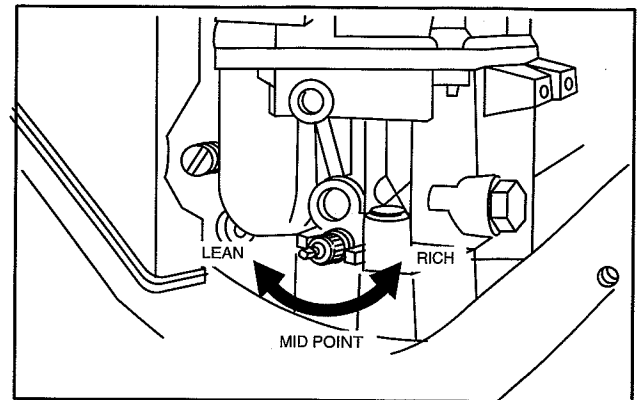

Fig. 138 – Adjust Idle Mixture

8. Deactivate idle down device, or remove jumper wire. Engine should accelerate smoothly to top governed speed.
 - a. Readjust idle mixture screw 1/8 turn richer if necessary.
9. IF CARBURETOR IS EQUIPPED WITH AN IDLE MIXTURE LIMITER CAP, INSTALL AT THIS TIME.
 - a. Position limiter cap so that stop on limiter cap is at mid point between stops on carburetor body. Press limiter into position using knock out pin, Tool #19135 as shown in, Fig. 139.

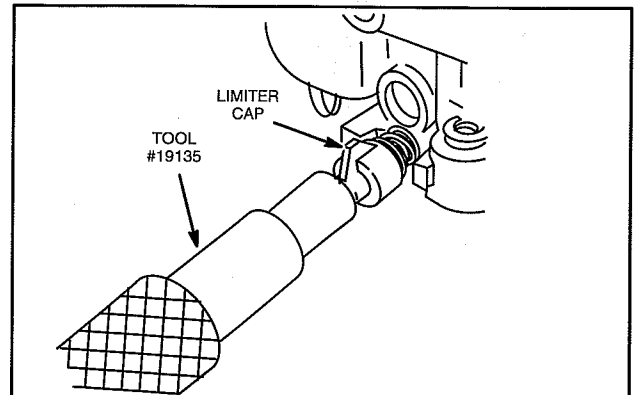

Fig. 139 – Install Limiter Cap

Carburetor Adjustment Engine Models 351400 – 380400, 351700 And 380700

The ohv twin cylinder engine carburetor fuel mixture adjustment procedure is unique. Perform adjustments exactly in the sequence shown.

Initial Adjustment Engine Models 351400 – 380400, 351700 And 380700

1. Turn idle mixture screw for #1 cylinder clockwise until it just seats. **DO NOT FORCE.**
2. Then turn screw counter-clockwise 3/4 turn, Fig. 140.
3. Repeat for #2 cylinder.

This setting will permit engine to start. Final adjustment will be made with engine running.

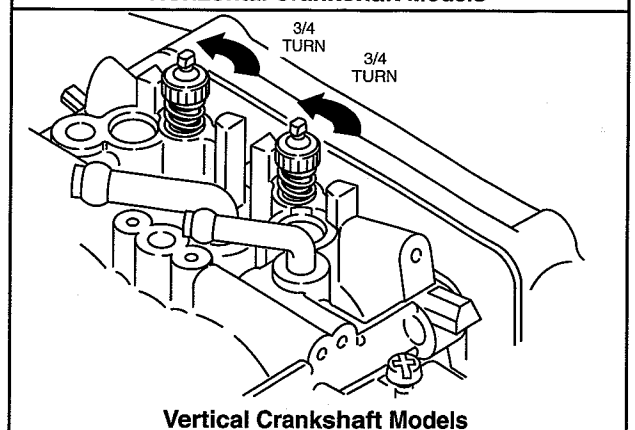
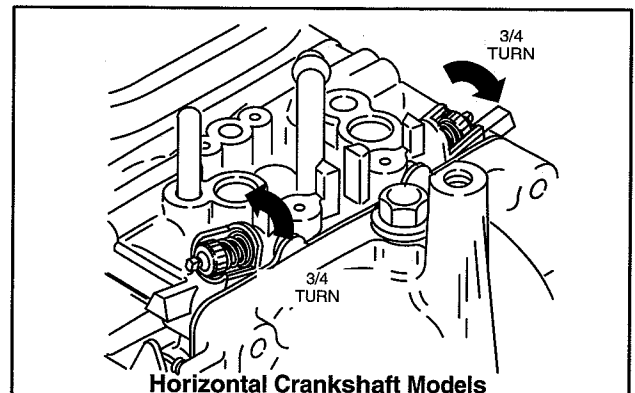

Fig. 140 – Initial Adjustment

Final Adjustment

Engine Models 351400 – 380400, 351700 And 380700

All carburetor adjustments with engine running must be made with the air cleaner installed as done at the factory.

Important: Idle mixture adjustment must be performed with the engine running at 1200 rpm.

The following tools are required when making carburetor adjustments, Fig. 141.

1. An accurate tachometer, such as Tool #19200 or #19389.
2. Tang bender, Tool #19352.

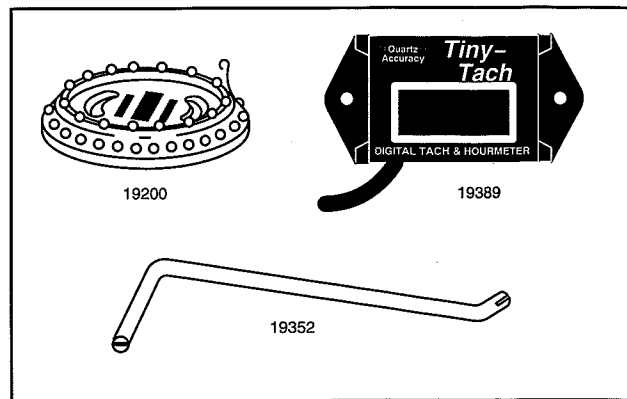

Fig. 141 – Adjustment Tools

Start engine and run it for approximately 5 minutes to allow engine to reach operating temperature.

1. Move equipment control lever to SLOW position.
2. Hold throttle lever against idle speed screw and temporarily adjust idle to **1200 RPM**, Fig. 142.
3. While holding throttle lever, SLOWLY turn idle mixture screw for #1 cylinder clockwise until engine speed just starts to slow (lean mixture).

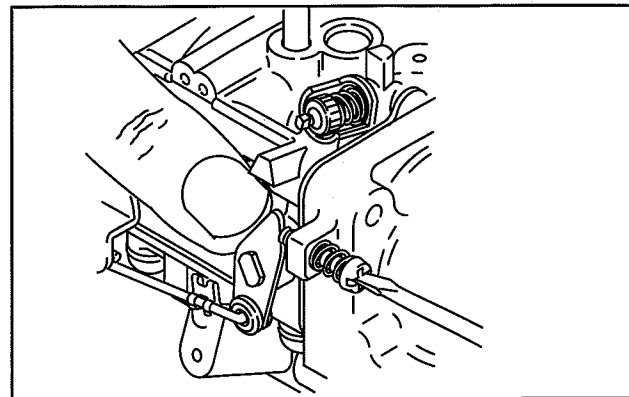

Fig. 142 – Adjust Idle Speed

4. Then turn idle mixture screw counterclockwise 3/8 turn, Fig. 143.

Note: It may be necessary to readjust idle speed screw to 1200 RPM before proceeding.

5. Adjust idle mixture screw for #2 cylinder as described in steps 3 and 4.
6. Now, readjust idle speed screw to RPM shown below, if necessary.
 - a. 1200 RPM – Governed idle spring Part #805453 (red).
 - b. 900 RPM – Governed idle spring Part #805454 (white).
7. Release throttle lever. Note RPM.
8. If necessary, use tang bending Tool, #19352, and bend governed idle tang, (Fig. 144) to obtain RPM shown:
 - a. 1750 RPM – Governed idle spring Part #805453 (red).
 - b. 1100 RPM – Governed idle spring Part #805454 (white).

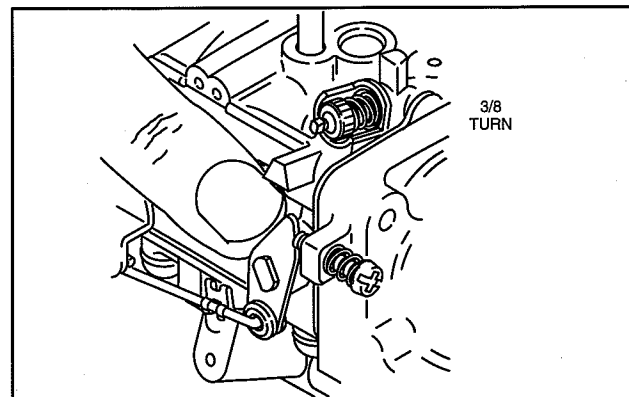

Fig. 143 – Adjust Idle Mixture

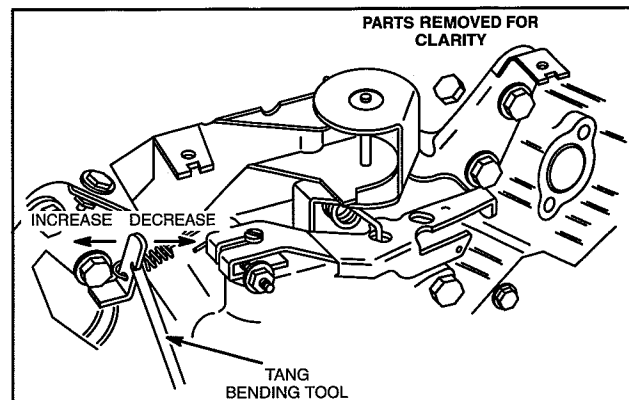

Fig. 144 – Adjust Governed Idle

9. IF CARBURETOR IS EQUIPPED WITH AN IDLE MIXTURE LIMITER CAPS, INSTALL AT THIS TIME.

- a. Position limiter cap so that stop on limiter cap is at mid point between stops on carburetor body. Press limiter into position using knock out pin, Tool #19135 as shown in, Fig. 145.
- b. Repeat for other idle mixture valve.

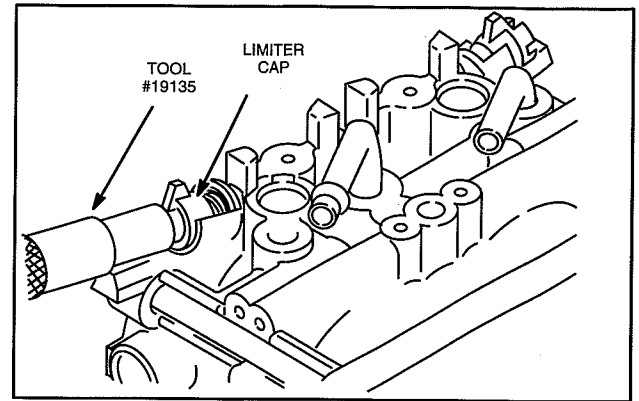

Fig. 145 – Install Limiter Caps

10. With equipment control lever in SLOW position and engine running at governed idle RPM, use tang bender, Tool #19352, and bend throttle restrictor tang so that tang just contacts governor lever. Fig. 146.
11. Move equipment control to FAST position. Engine should accelerate smoothly.
 - a. Readjust idle mixture valve 1/8 turn richer if necessary.

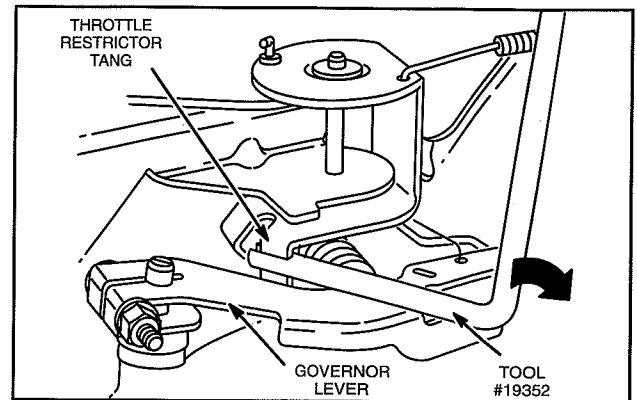

Fig. 146 – Adjust Throttle Restrictor

ANTI-AFTERFIRE SYSTEM

Some carburetors are equipped with a fuel shut off solenoid controlled by the equipment ignition switch. When the equipment switch is in the “Off” position, the solenoid valve plunger closes, stopping fuel flow through the fixed main jet. When the switch is in the “On” and “Start” position, the solenoid valve opens, allowing normal fuel flow. Solenoid is operating properly if a click is heard when equipment ignition switch is turned “On” and “Off.” If solenoid is not working (defective solenoid or equipment wiring), the engine will not start or run.

Note: Fuel shut-off solenoid requires a minimum of 9 volts DC to function.

Testing Solenoid

If solenoid does not click, the problem may be in equipment wiring or solenoid. To determine whether problem is with wiring or solenoid, perform the following tests in the order shown.

Test Equipment

The digital multimeter, Tool #19390 is required to test the solenoid equipment wiring.

The following tests will be performed with the meter in the $V \text{ ---}$ (DC volts) position, Fig. 147.

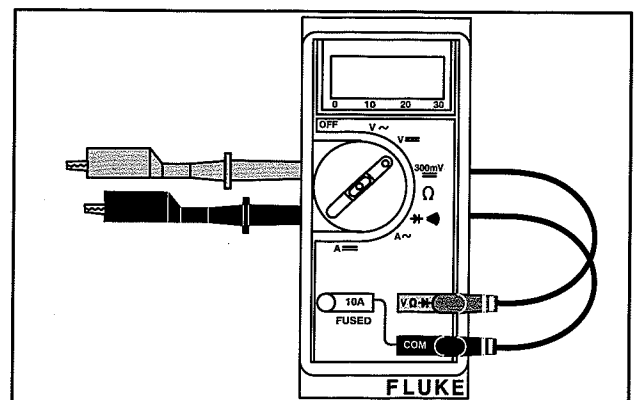

Fig. 147

Testing Equipment Wiring

1. With keyswitch in OFF position, disconnect equipment wiring harness connector from solenoid.
2. Attach red meter test lead into equipment wiring harness connector.
3. Attach black test lead to a good ground, Fig. 148.
4. Turn keyswitch to ON position.
 - a. Meter should display battery voltage at connector.

If meter does not display battery voltage, problem is with wiring harness. Check for loose or broken wire. If meter displays battery voltage, test solenoid.

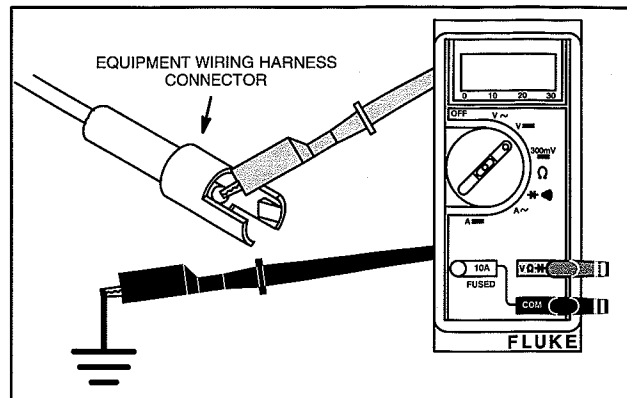

Fig. 148 – Checking Wiring

Testing Solenoid

1. Remove solenoid from carburetor.
2. Place either terminal of a 9 volt transistor battery on the solenoid connector and other terminal on body of solenoid, Fig. 149.
3. Plunger should retract freely.
4. When battery is removed, plunger should return freely.

Replace solenoid if plunger sticks or doesn't move.

Note: **Engine Model** 350400 equipped with Mikuni carburetor: When bench testing solenoid, tip must be retracted manually approximately 0.8 mm (.030") before solenoid will energize. With 9 volt transistor battery applied to solenoid, apply finger pressure to tip of solenoid.

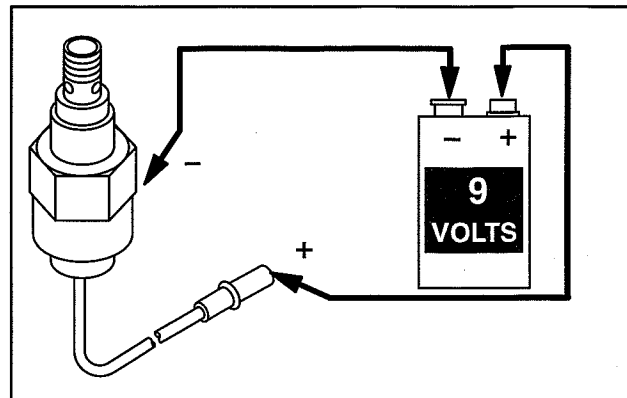

Fig. 149 – Checking Solenoid

FUEL PUMP

The fuel pump allows for remote fuel tank installations. The fuel pump will prime at 12" (30.5 cm) maximum lift. Fuel pump pressure is 0.10 Bar (1.5 psi). The fuel pump is available as an assembly only. The pump is operated by pulsating crankcase vacuum from the engine. The vacuum pulse line is installed on the No. 1 cylinder valve cover. Replace fuel lines and vacuum pulse line if stiff and brittle. An air leak at the fuel pump pulse line hose connections will result in improper fuel flow.

Note: **Some engines** are manufactured without a fuel pump where a remote fuel pump is required. The remote fuel pump is supplied by the equipment manufacturer.

FUEL PUMP PRESSURE MUST NOT EXCEED 0.10 Bar (1.5 PSI).

Excessive fuel pump pressure may result in an over rich carburetor mixture and ultimately cylinder scoring and or, other engine damage, resulting from crankcase oil dilution from gasoline.

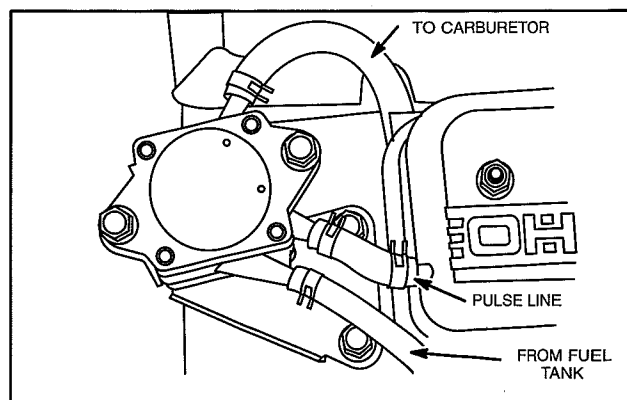

Fig. 150

Inline Fuel Filter Service

Replace inline fuel filter yearly or every 100 hours, whichever occurs first. Replace filter if dirt or water are present. See illustrated parts list for correct fuel filter.

Important: When replacing fuel filter on engines equipped with 9 quart fuel tank, the fuel line from the carburetor must be routed over fuel shut off rod if engine is equipped with a Mikuni carburetor, or under fuel shut off rod if engine is equipped with Nikki carburetor, Fig. 151.

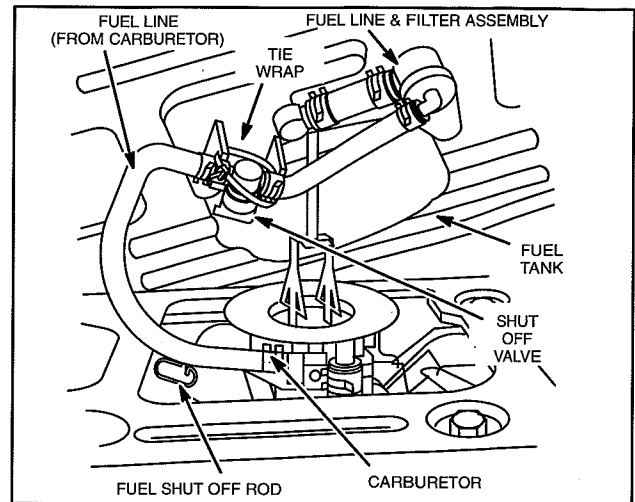

Fig. 151 – Fuel Line Routing

Early and current style fuel filter assemblies for 9 quart fuel tank shown in Fig. 152.

Fuel Shut-Off Valve

Engines equipped with optional fuel tank are equipped with a fuel shut-off valve. Inspect valve for ease of operation and leakage. Replace valve if operation is difficult or if valve leaks.

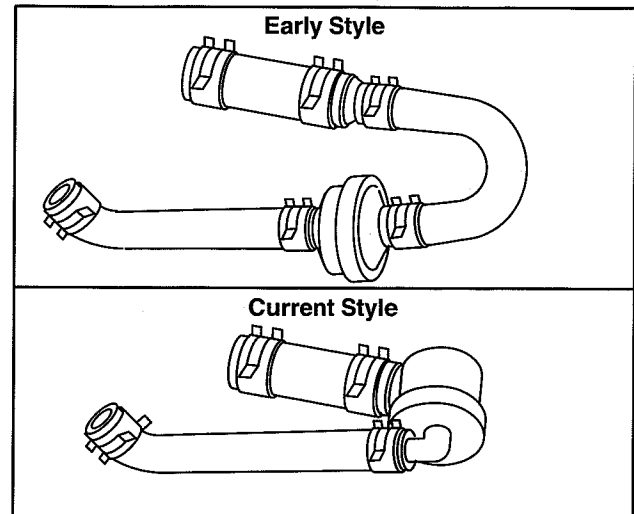

Fig. 152 – Fuel Filter Assemblies

Section 4

Gov. Controls & Governor

| Section Contents | Page |
|--|----------|
| MECHANICAL GOVERNOR | |
| General Information | 2 |
| Speed Regulation | 2 |
| Governed Idle | 2 |
| Remote Control Wire Travel | 3 |
| Choke Control Adjustment | 3 |
| MECHANICAL GOVERNOR | |
| Disassemble | 3 |
| Inspect Governor | 4 |
| Remove Governor Shaft | 4 |
| Replace Governor Shaft Bushings | 4 |
| Install Governor Shaft | 5 |
| Assemble | 5 |
| STATIC GOVERNOR ADJUSTMENT | 6 |
| DYNAMIC GOVERNOR ADJUSTMENT | 6 |
| General Information – All Models | 6 |
| Manual Friction and Remote Speed Controls | 6 |
| Fixed Speed Adjustable | 7 |
| Fixed Speed Adjustable – Generators | 8 |
| Adjust Secondary Governor Spring | 8 |
| Remote Speed Control Engines Equipped With Secondary Governor Spring | 9 |
| Adjust Secondary Governor Spring | 8 |
| PERFORMANCE CONTROL™ ELECTRONIC GOVERNOR | |
| General Information | 11 |
| Checking Performance Control™ Electronic Governor – Dynamic Check | 12 |
| Checking Performance Control™ Electronic Governor – Static Check | 12 |
| Replacing Actuator | 13 |

MECHANICAL GOVERNOR

General Information

The purpose of the mechanical governor is to maintain, within certain limits, a desired engine speed, even though loads may vary. The governor spring tends to pull the throttle open. The force of the flyweights, which are operated by centrifugal force, tends to close the throttle. The engine speed at which these two forces balance is called the governed speed. The governed speed can be varied by changing governor spring tension. If a governor spring must be replaced, consult the appropriate Illustrated Parts List. Select the proper governor springs by engine type number.

To comply with specific top governed speed limits, Briggs & Stratton supplies manufacturers with engines having an adjustable top speed limit, which is set to equipment manufacturers' specifications.



CAUTION: AFTER A NEW GOVERNOR SPRING IS INSTALLED, CHECK ENGINE TOP GOVERNED SPEED WITH AN ACCURATE TACHOMETER.

Vanguard™ OHV Twin engines may be equipped for remote control, manual friction or fixed speed adjustable governor controls. Figures 1, 2 and 3.

Speed Regulation

Remote governor controls (supplied by equipment manufacturer) and manual friction (mounted on engine) control engine speed by increasing or decreasing tension on governor spring(s) to obtain desired engine speed. Both controls will provide governor control at all positions.

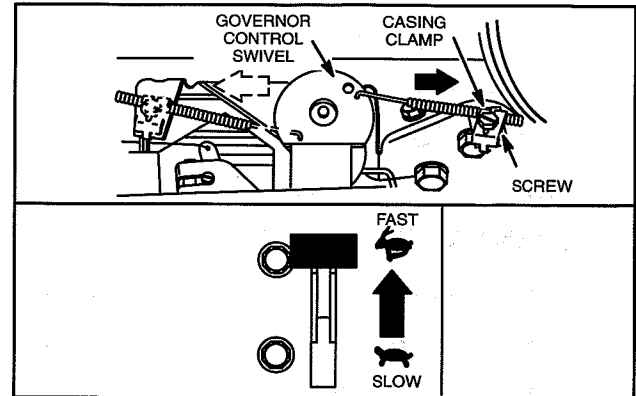

Fig. 1 – Remote Control

Governed Idle

OHV Twin cylinder engines equipped for manual friction or remote control have a governed idle system. A throttle restrictor permits the engine to maintain engine speed when a load is applied with the equipment control in the SLOW position.

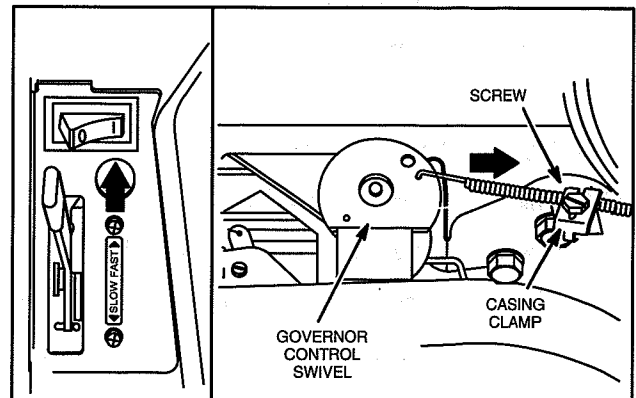

Fig. 2 – Manual Friction Control

The fixed speed adjustable is used in applications where a constant speed is required such as generator applications.

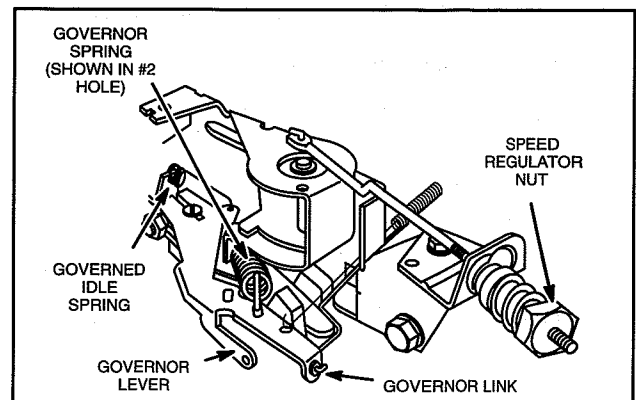

Fig. 3 – Fixed Adjustable Control

Remote Control Wire Travel

In order to make proper remote control adjustments, the travel of the remote control wire must be not less than 35 mm (1-3/8") with controls mounted in equipment, Fig. 4.

Some control brackets are equipped with a plastic swivel for the control wire. The control wire has a 90 degree bend and snaps into the swivel. The length of the bend should not exceed 6 mm (1/4"), Fig. 4.

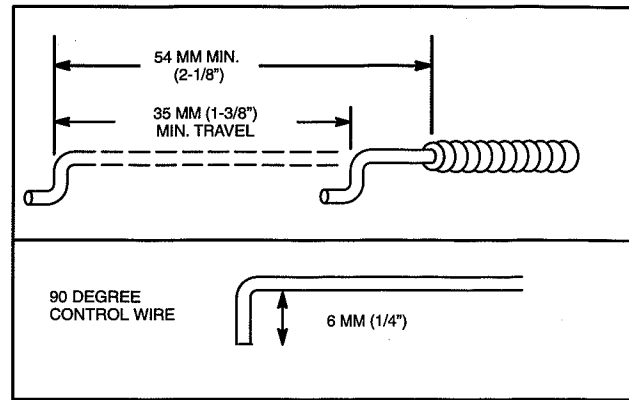

Fig. 4 – Control Wire

Speed Control Wire Adjustment

Note: Manual friction and remote control adjustment procedure is identical.

1. Loosen control casing clamp at governor control bracket, Fig. 5.
2. Move speed control lever to "FAST" position.
3. Move control casing and wire in direction shown by arrow until governor control swivel is at end of travel.
4. Tighten casing clamp screw.

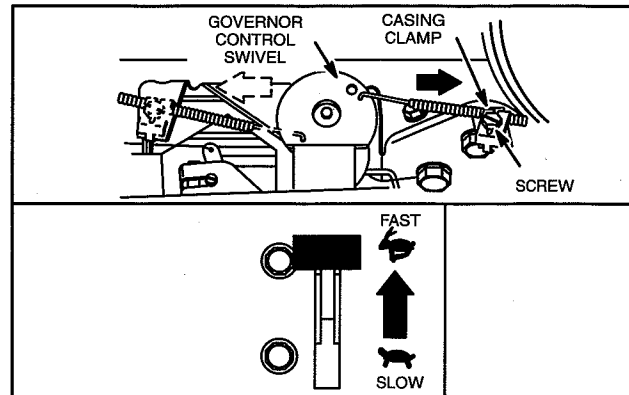

Fig. 5 – Throttle Adjustment

Choke Control Adjustment

Note: Be sure choke control wire is installed in #2 hole in choke lever.

1. Place choke control lever on equipment in "CHOKE" position.
2. Loosen control casing clamp screw.
3. Move control casing and wire until choke is completely closed.
4. Tighten casing clamp screw, Fig. 6.

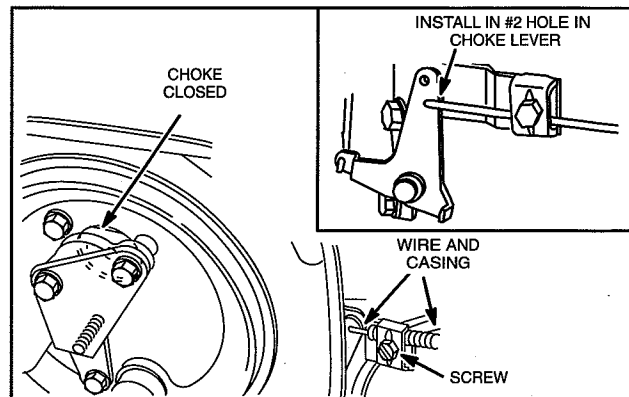

Fig. 6 – Choke Adjustment

MECHANICAL GOVERNOR Disassemble

Drain oil and remove engine from equipment. Remove spark plugs. Remove valve covers. Compress valve springs and remove push rods. See Section 5.

1. Disconnect governor link and spring at carburetor.
2. Disconnect governed idle spring (if equipped).
3. Loosen governor lever nut.
 - a. Remove governor lever from shaft, Fig. 7.

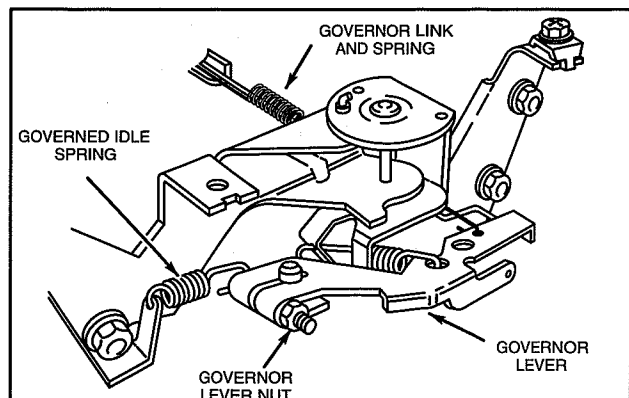

Fig. 7 – Remove Governor Lever

Remove rust, nicks or burrs from crankshaft.

4. Remove oil fill tube and dipstick assembly.
5. Remove crankcase cover, Fig. 8.
 - a. Discard gasket and "O"-ring.

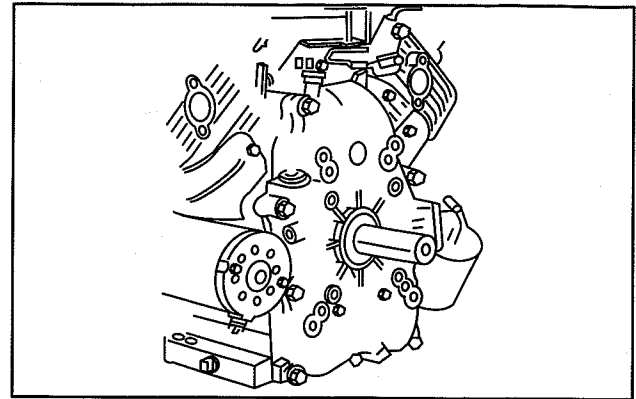

Fig. 8 – Remove Crankcase Cover

4

Inspect Governor

1. Governor spool must move freely on PTO journal of camshaft, Fig. 9.
 - a. Replace if spool sticks or bearing is damaged.
2. Flyweights must move freely on hinge pins.
 - a. Replace camshaft if hinge pins are loose or governor spool does not move freely on journal.

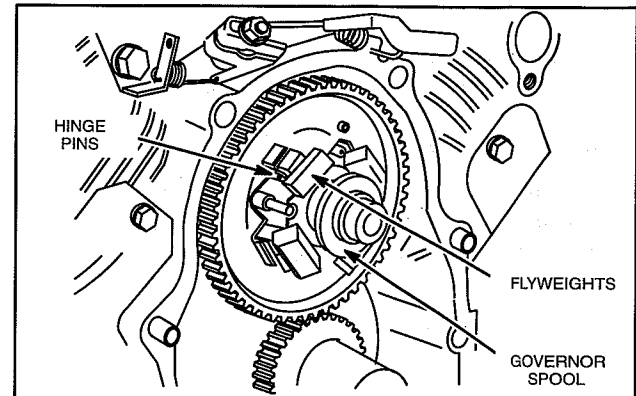

Fig. 9 – Check Governor

Remove Governor Shaft

1. Remove cotter pin and collar.
2. Slide governor shaft out of bushings.
 - a. Discard cotter pin and seal.
3. Check governor shaft and bushings for wear or damage.

Replace as required.

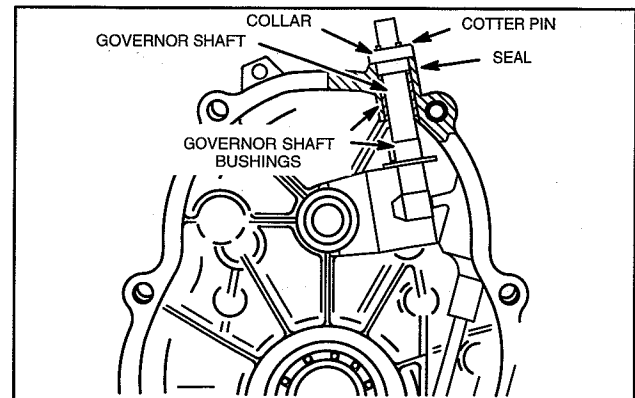

Fig. 10 – Remove Governor Shaft

Replace Governor Shaft Bushings

1. Press out upper bushing using bushing driver, Tool #19204.
2. Lubricate new bushing with engine oil and press in with bushing driver, Tool #19204.

Note: Lower bushing is a slip fit. If bearing for lower bushing is worn, the crankcase cover must be replaced.

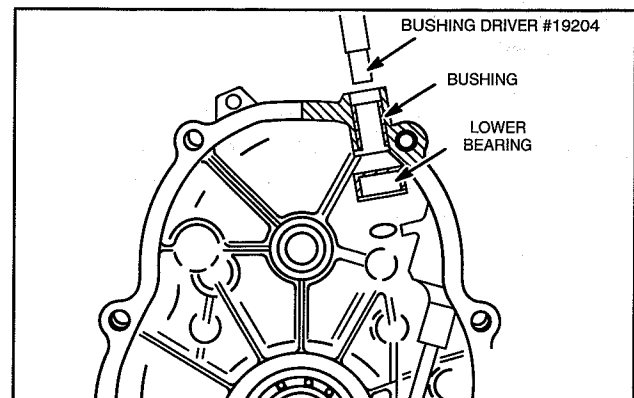

Fig. 11 – Install Bushing

Install Governor Shaft

1. Assemble lower bushing to governor shaft with thrust flange down, Fig. 12.
2. Slide shaft up through lower bearing and upper bushing.
3. Install new seal, collar and cotter pin.
 - a. Governor shaft must rotate freely.
4. Rotate governor shaft so that paddle rests against camshaft bearing support.

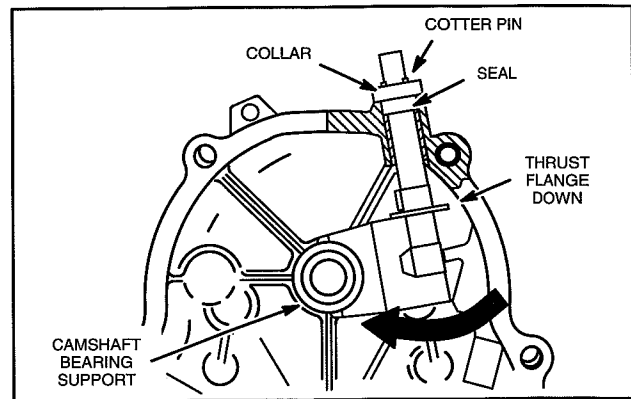

Fig. 12 – Install Governor Shaft

Assemble

1. Assemble governor spool to camshaft, Fig. 13.
 - a. Make sure that spool engages flyweights and slot on spool fits over locating pin.
 - b. Install new “O”-ring in cylinder.

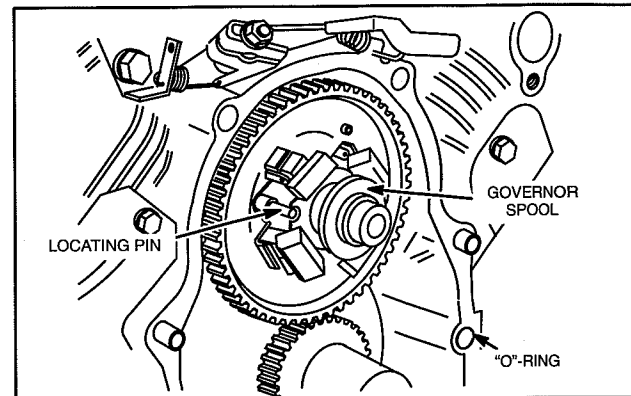

Fig. 13 – Install Governor Spool

2. Insert proper seal protector through oil seal.
3. Install crankcase cover or sump with new gasket.
 - a. Torque screws in sequence shown to 17.0 Nm (150 in. lbs.), Fig. 14.
4. Reinstall oil fill tube and dipstick assembly.

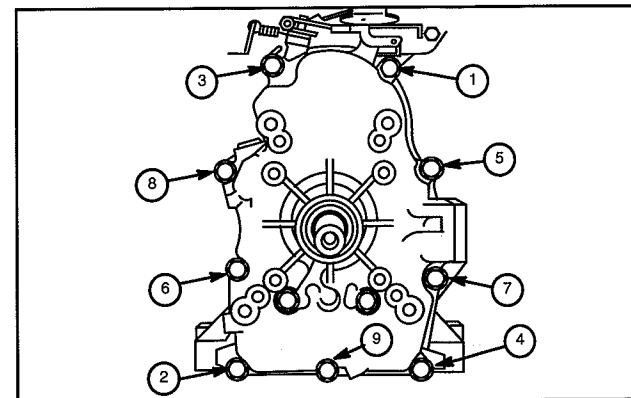

Fig. 14 – Torque Crankcase Cover

5. Reassemble governor lever to shaft, Fig. 15.
 - a. Reassemble governor link and spring at carburetor.
 - b. Reassemble governed idle spring.

DO NOT tighten nut at this time.

6. Install push rods in their original position.
7. Compress valve spring with rocker arm and insert push rod into rocker arm socket.

Be sure push rods remain seated in recess in tappets.

8. Install valve covers with new gaskets and valve cover seals.
 - a. Torque nuts to 3.0 Nm (25 in. lbs.).

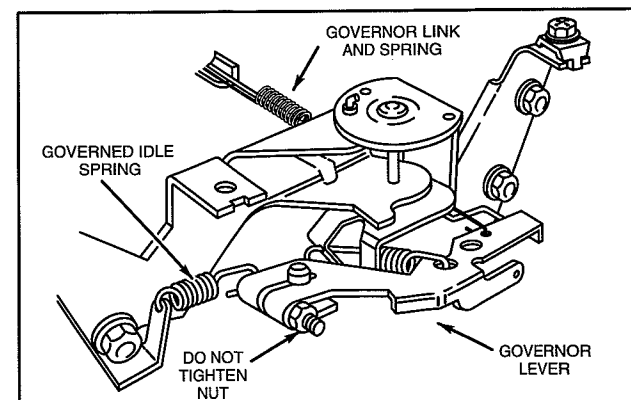

Fig. 15 – Install Governor Lever



WARNING: BEFORE STARTING OR RUNNING ENGINE, STATIC ADJUSTMENT OF THE GOVERNOR MUST BE COMPLETED! FAILURE TO MAKE THE STATIC ADJUSTMENTS FIRST COULD RESULT IN ENGINE OVERSPEEDING WHICH MAY RESULT IN ENGINE DAMAGE, PROPERTY DAMAGE OR PERSONAL INJURY.

STATIC GOVERNOR ADJUSTMENT

1. With governor lever nut loose, push on governor lever until throttle is wide open. **Do not bend governor link or distort governor lever.**
2. Rotate governor shaft counter-clockwise as far it will go, Fig. 16.
 - a. Torque governor nut to 8.0 Nm (70 in. lbs.).
3. Install throttle and choke control cables and check for proper operation.

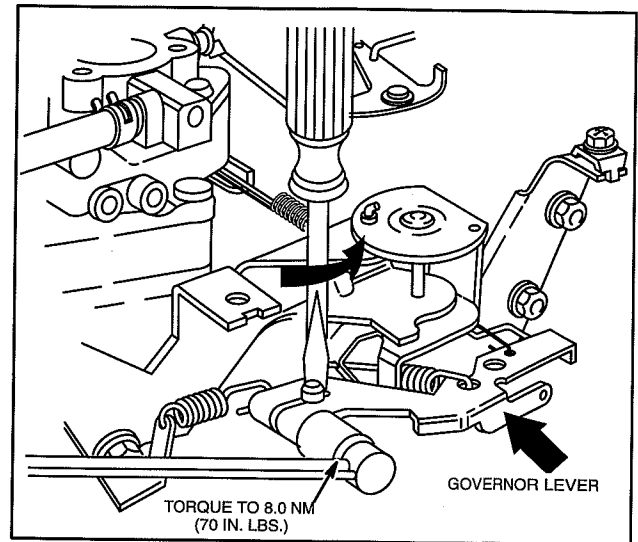

Fig. 16 – Static Governor Adjustment

DYNAMIC GOVERNOR ADJUSTMENT

General Information – All Models

Note: Carburetor mixture adjustments must be made before adjusting governed idle, throttle restrictor and top no load RPM.

The following tools are required when making governor adjustments Fig. 17.

1. An accurate tachometer, such as Tool #19200 or #19389.
2. Tang bender, Tool #19352.

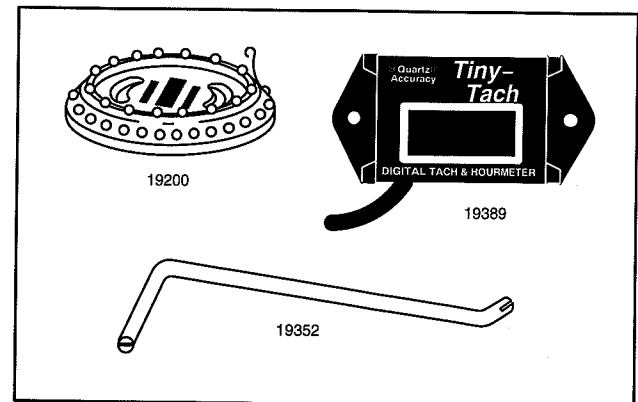

Fig. 17 – Tools

Manual Friction and Remote Speed Controls

Governor spring is installed in #1 hole in governor lever, Fig. 18.

Start and run engine for approximately 5 minutes to allow engine to warm up.

1. Move control lever to SLOW position.
2. Bend governed idle tang to obtain RPM shown:
 - a. 1750 RPM – Governed idle spring Part #805453 (red).
 - b. 1100 RPM – Governed idle spring Part #805454 (white).

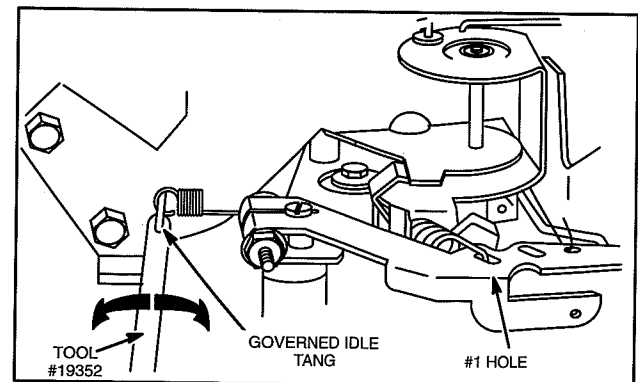

Fig. 18 – Adjust Governed Idle

3. With equipment control lever in SLOW position and engine running at governed idle RPM, use tang bender, Tool #19352, and bend throttle restrictor tang so that tang just contacts governor lever, Fig. 19.

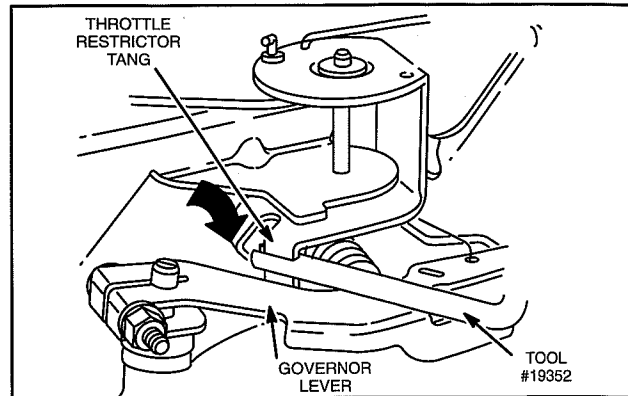

Fig. 19 – Adjusting Throttle Restrictor

4. Refer to Service Engine Sales Microfiche, MS-6225 or the Service Engine Sales Manual, MS-4052, for Top No Load RPM by engine Model and Type Number.
5. Move control throttle lever to “FAST” position and check engine RPM.
6. Bend tang with Tool #19352 to obtain desired Top No Load RPM, Fig. 20.

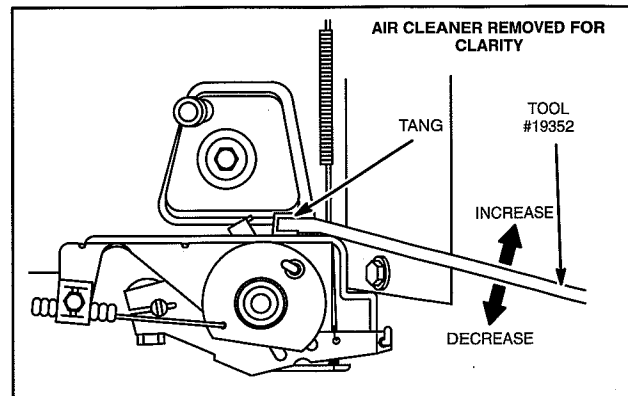

Fig. 20 – Adjusting Top No-Load Speed

Fixed Speed Adjustable

Governor spring is installed in #1 hole in governor lever, Fig. 21.

Start and run engine for approximately 5 minutes to allow engine to warm up.

1. Turn fixed speed adjustable control nut counter-clockwise until control swivel contacts slow speed stop.
2. Bend governed idle tang to obtain RPM shown:
 - a. 1750 RPM – Governed idle spring Part #805453 (red).
 - b. 1100 RPM – Governed idle spring Part #805454 (white).
3. Bend throttle restrictor tang so that tang just contacts governor lever, Fig. 22.

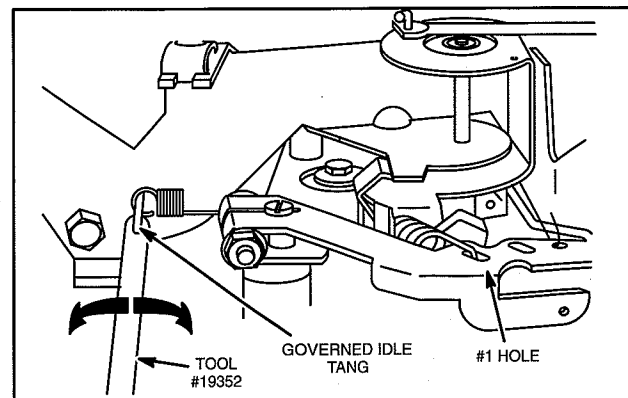

Fig. 21 – Adjusting Governed Idle

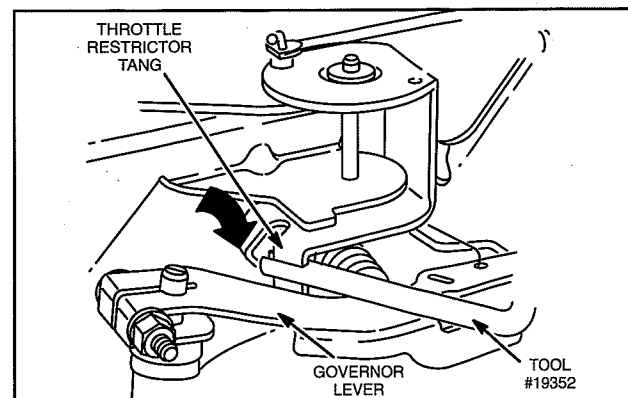

Fig. 22 – Adjusting Throttle Restrictor

4. Refer to Service Engine Sales Microfiche, MS-6225 or the Service Engine Sales Manual, MS-4052, for Top No Load RPM by engine Model and Type Number.
5. Turn fixed speed adjustable control nut clockwise until desired Top No Load RPM is obtained, Fig. 23.

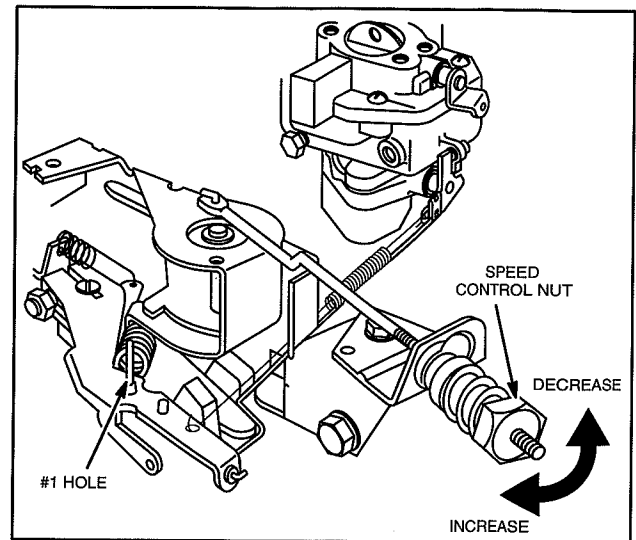

Fig. 23 – Governor Adjustment, Fixed Speed

Fixed Speed Adjustable – Generators

No governed idle spring is used with this system. No throttle restrictor adjustment is necessary. The primary governor spring is installed in #2 hole on governor lever. A secondary governor spring is installed as shown in Fig. 24.

Important: Secondary governor spring must be adjusted before the engine is started. Perform adjustment in the sequence shown.

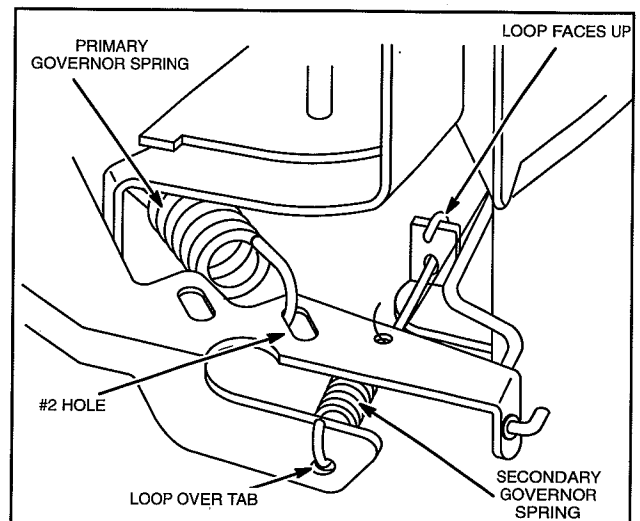

Fig. 24 – Governor Springs, Generator

Adjust Secondary Governor Spring

1. Disengage the adjustable fixed speed control nut.
2. Loosen and remove fixed speed adjustable control nut, spring and retainer.
3. Rotate governor control swivel counterclockwise to end of travel.
4. Install adjustment gauge, Tool #19385, with notch over end of governor lever and flat end of tool against governor control bracket as shown in Fig. 25.
5. Hold gauge in position and bend tab "A" so that all slack is removed from secondary governor spring between its two anchor points, Fig. 25. **DO NOT STRETCH SPRING.**
6. Remove adjustment gauge.

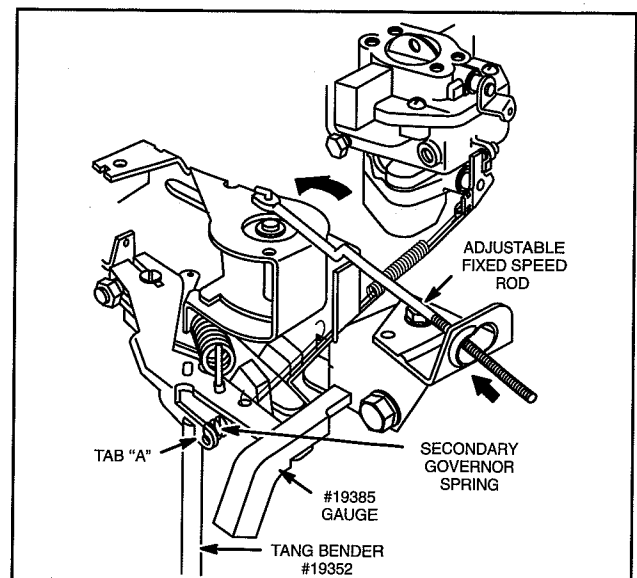

Fig. 25 – Adjusting Top No Load Speed

Start and run engine for approximately 5 minutes to allow engine to warm up.

1. With engine running, pull control rod out until swivel is against stop and hold in this position, Fig. 26.
2. Use tang bender and adjust to **Top No Load RPM**, for the type of generator listed in Table 1.
3. Re-install control nut, spring and retainer. Turn nut clockwise until threads on control rod are visible from end of nut, Fig. 26.

TABLE NO. 1

| Generator Type | Top-No-Load RPM | Regulated No-Load RPM |
|----------------------|-----------------|-----------------------|
| 3600 RPM 60 Cycle | 4250 RPM | 3750 RPM |
| 3000 RPM 50 Cycle | 3600 RPM | 3150 RPM |

4. Engage fixed speed adjustable control nut and adjust to **Regulated No Load RPM** for the type of generator listed in Table 1, Fig. 27.
 - a. Turn nut clockwise to increase speed.
 - b. Turn nut counterclockwise to decrease speed.

Note: Final adjustment should be made with generator loaded to rated capacity or manufacturers specifications.

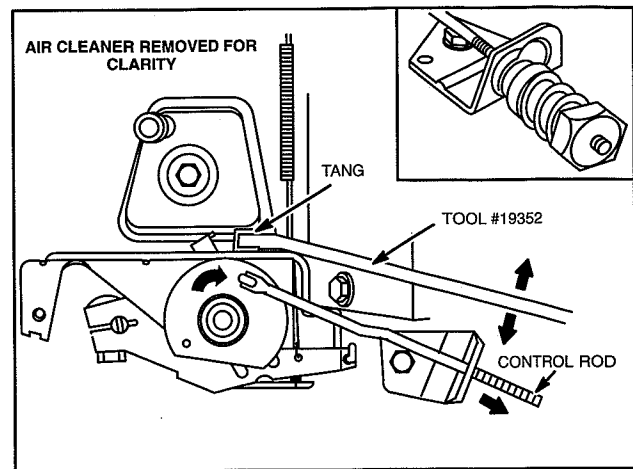

Fig. 26 – Adjusting Top No Load Speed

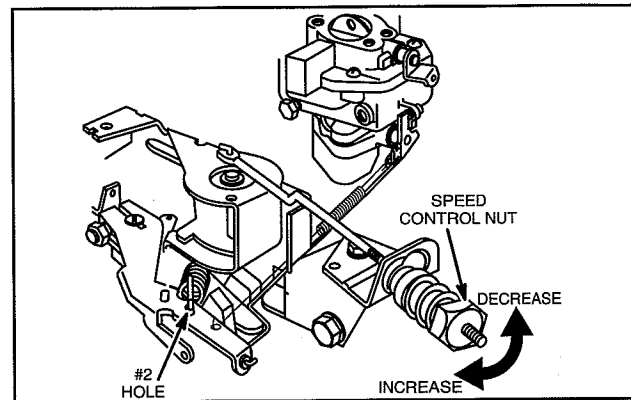

Fig. 27 – Adjusting Governed Idle

Remote Speed Control Engines Equipped With Secondary Governor Spring

Some Vanguard™ OHV-Twin engines with remote speed control are equipped with a secondary governor spring. The primary governor spring is installed in #1 hole on governor lever.

Important: Secondary governor spring must be adjusted before the engine is started. Perform adjustment in the sequence shown.

Adjust Secondary Governor Spring

1. Move equipment control to SLOW position.
2. Install adjustment gauge, Tool #19385, with notch over end of governor lever and flat end of tool against governor control bracket as shown in Fig. 28.
3. Hold gauge in position and bend tab "A" so that all slack is removed from secondary governor spring between its two anchor points, Fig. 28. **DO NOT STRETCH SPRING.**
4. Remove adjustment gauge.

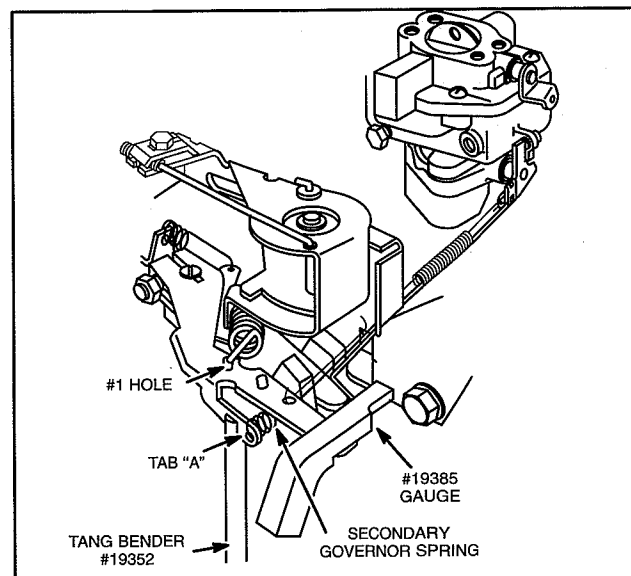

Fig. 28 – Adjusting Governed Idle

Start and run engine for approximately 5 minutes to allow engine to warm up.

1. Move control lever to SLOW position.
2. Bend governed idle tang to obtain RPM shown, Fig. 29:
 - a. 1750 RPM – Governed idle spring Part #805453 (red).
 - b. 1100 RPM – Governed idle spring Part #805454 (white).

Note: Engine Model 303447 Type 0411-01:
Adjust governed idle to 1350 RPM \pm 50 RPM.

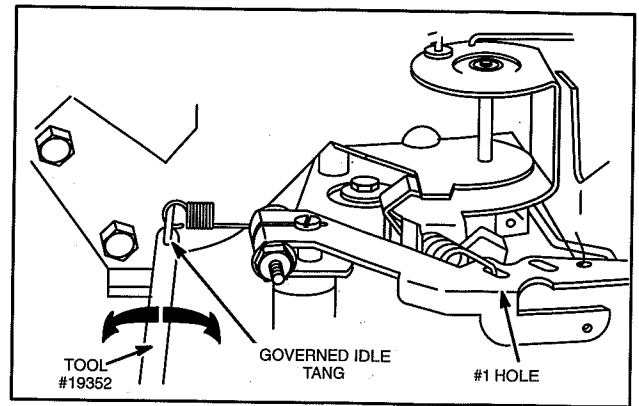

Fig. 29 – Adjusting Governed Idle

3. With equipment control lever in SLOW position and engine running at governed idle RPM, use tang bender, Tool #19352, and bend throttle restrictor tang so that tang just contacts governor lever, Fig. 30.

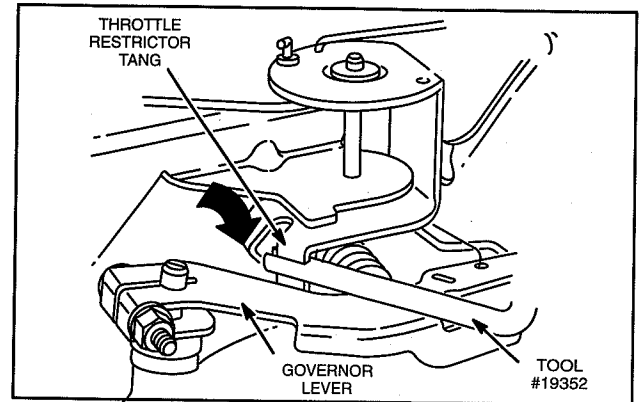

Fig. 30 – Adjusting Throttle Restrictor

4. Refer to Service Engine Sales Microfiche, MS-6225 or the Service Engine Sales Manual, MS-4052, for Top No Load RPM by engine Model and Type Number.
5. Move control throttle lever to "FAST" position and check engine RPM.
6. Bend tang with Tool #19352 to obtain desired Top No Load RPM, Fig. 31.

Note: Engine Model 303447 Type 0411-01: Set Top No Load to 2900 RPM \pm 50 RPM.

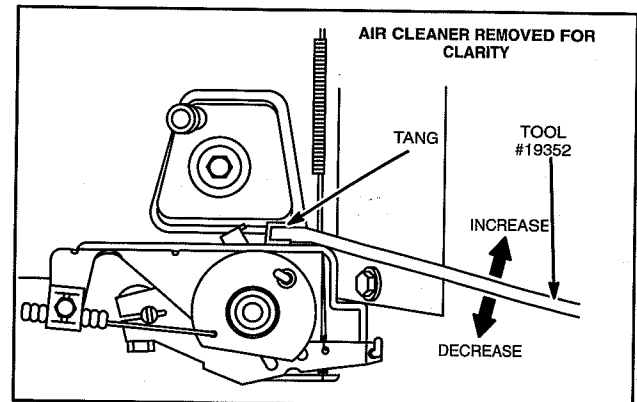

Fig. 31 – Adjusting Top No Load Speed

PERFORMANCE CONTROL™ ELECTRONIC GOVERNOR

General Information

Some V-Twin engines are equipped with the Performance Control™ electronic governor control system for generator or welder applications. The electronic governor provides more responsive governing than a mechanical governor system. Engines equipped with the Performance Control™ electronic governor control system have no mechanical governor components. The Performance Control™ electronic governor control system cannot be retro-fitted to mechanical governor engines.

The Performance Control™ electronic governor control system consists of an electronic control module, wiring and stop switch harness and a throttle actuator. The control module is equipped with an idle down circuit for applications requiring that feature. By cutting and removing the yellow or red loop wire, the control module may be converted to 50 cycle – 3000 RPM generator applications.

Performance Control™ Electronic Governor Wiring Diagram

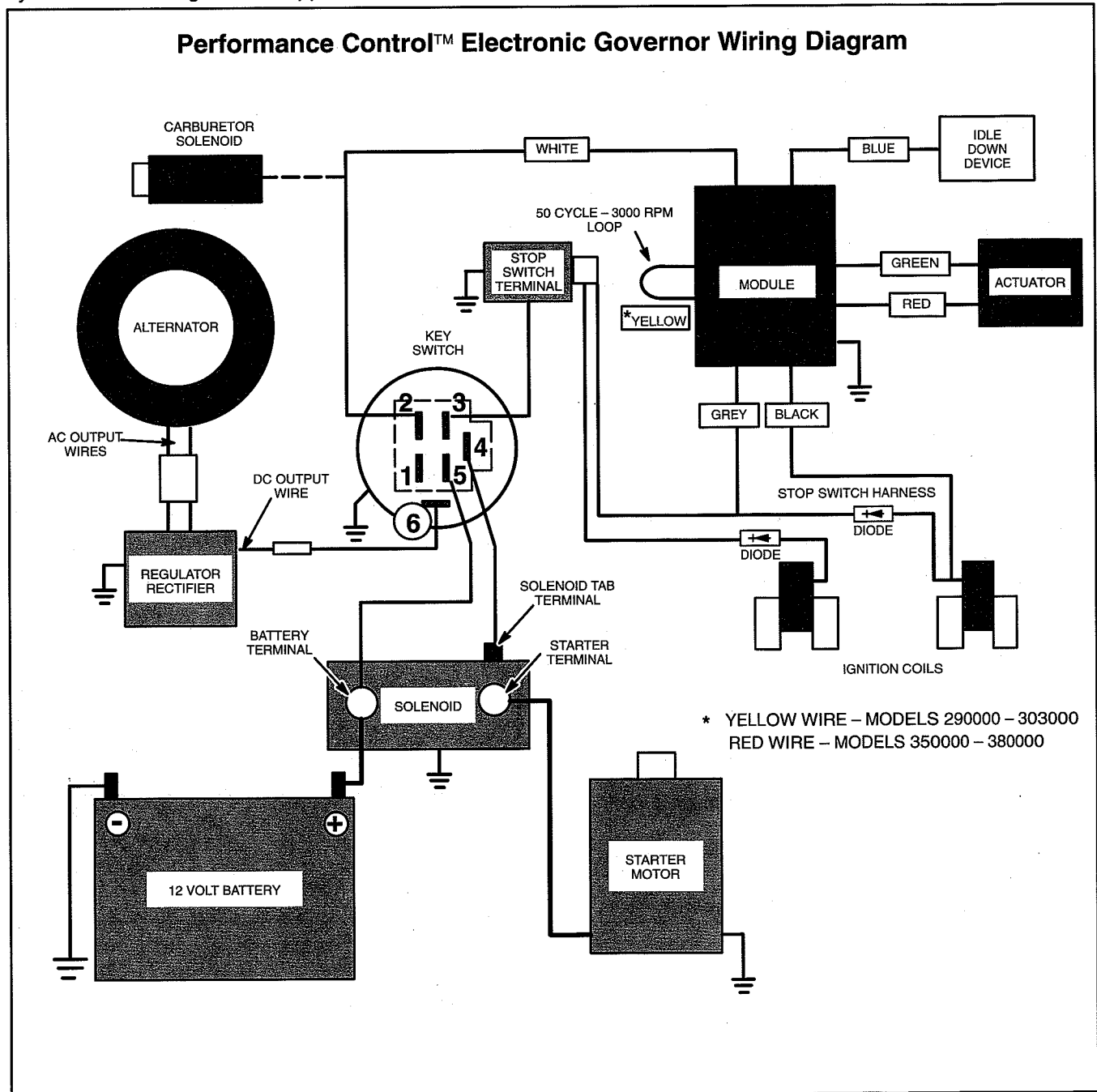

Checking Performance Control™ Electronic Governor – Dynamic Check

Perform dynamic check exactly in order shown.

1. Start engine and check RPM. Top governed speed should be:
 - a. 3600 RPM – 60 cycle applications.
 - b. 3000 RPM – 50 cycle applications (yellow or red loop removed).
2. Manually move throttle link to wide open throttle, Fig. 32.
 - a. Engine should not exceed 4000 RPM (approximately).
3. With engine running at top governed speed, attach one end of a jumper wire to BLUE wire from control module and attach other end to good ground, Fig. 33.
 - a. After 4 – 6 seconds engine speed should return to idle (approximately 1750 RPM).

Note: Idle speed may vary according to equipment manufacturers specifications.
4. Remove jumper wire from ground. Engine should return to top governed speed.

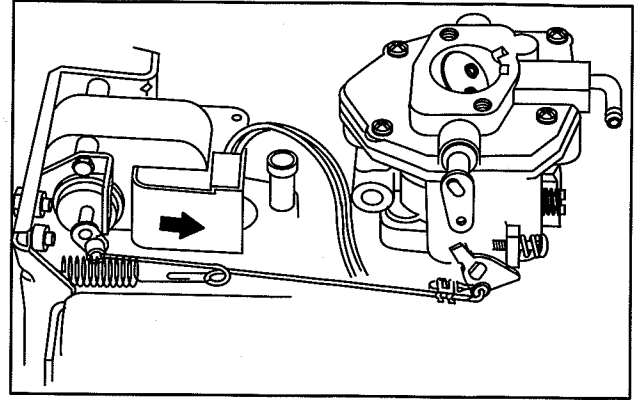

Fig. 32 – Dynamic Check

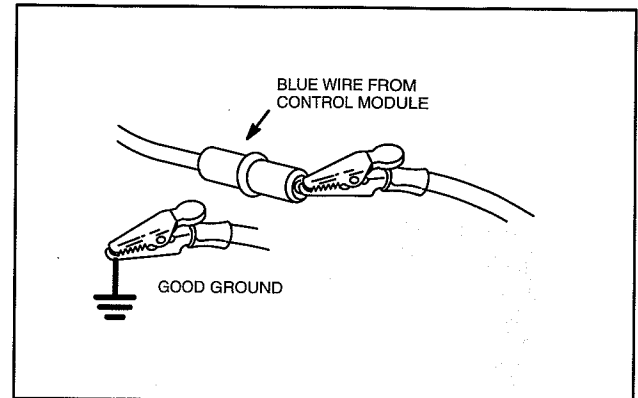

Fig. 33 – Dynamic Check

Checking Performance Control™ Electronic Governor – Static Check

To determine whether a governor problem is being caused by the actuator or the control module, perform the following static check exactly in order shown.

A pair of jumper wires and a known good 12 volt battery is required.

1. Disconnect red and green wires from control module to actuator.
2. Attach jumper wires from battery to RED and GREEN wires to actuator, Fig. 34.
 - a. Attach 12 volt + (positive) to RED wire.
 - b. Attach 12 volt – (negative) to GREEN wire.
3. Actuator should move throttle lever to wide open position, Fig. 35.
 - a. If actuator does not move it is defective. Replace.
 - b. If actuator moves throttle to wide open position, the module is defective. Replace.

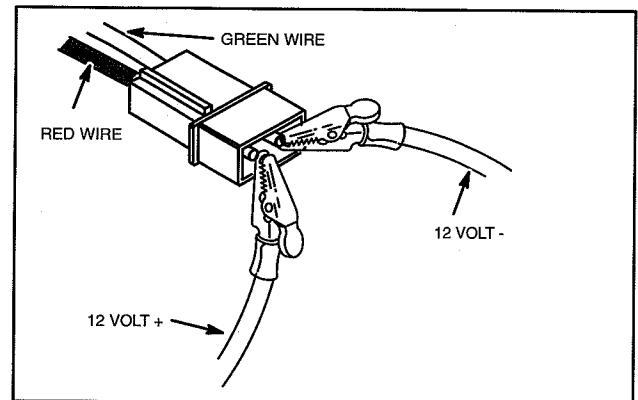

Fig. 34 – Static Check

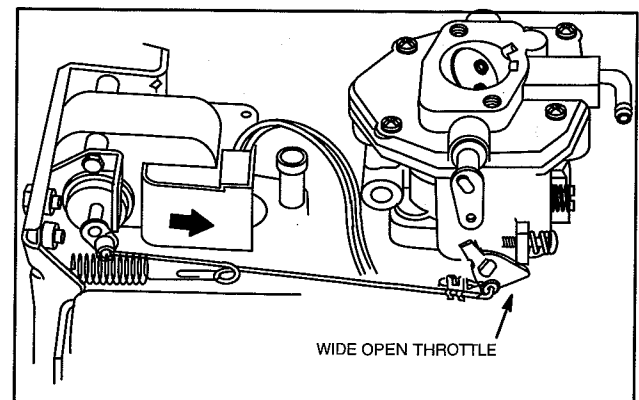

Fig. 35 – Static Check

Replacing Actuator

Remove:

1. Disconnect red and green wires from control module to actuator.
2. Remove air cleaner assembly.
3. Disconnect governor link at carburetor.
4. Remove governor control bracket with actuator.
5. Disconnect governor link from actuator and remove throttle return spring.
6. Remove two screws, nuts and actuator from control bracket.

Install:

1. Assemble actuator to governor control bracket, Fig. 36.
 - a. Torque screws and nuts to 3.0 Nm (30 in. lbs.).**Note:** Hold screws with 1/4 inch wrench when torquing nuts. Screws must NOT turn while torquing nuts.
2. Assemble governor link to actuator. Make sure link snaps into hole in actuator grommet.
3. Assemble throttle return spring through slot in governor control bracket with open end of spring facing out and through small hole in governor bracket.
4. Assemble governor control bracket assembly to engine.
 - a. Torque four 8mm screws to 17.0 Nm (150 in. lbs.).
 - b. Torque two 6mm screws to 10.0 Nm (70 in. lbs.).
5. Rotate actuator lever to position shown and connect governor link to carburetor, Fig. 37.
6. Connect red and green wires from control module to actuator.

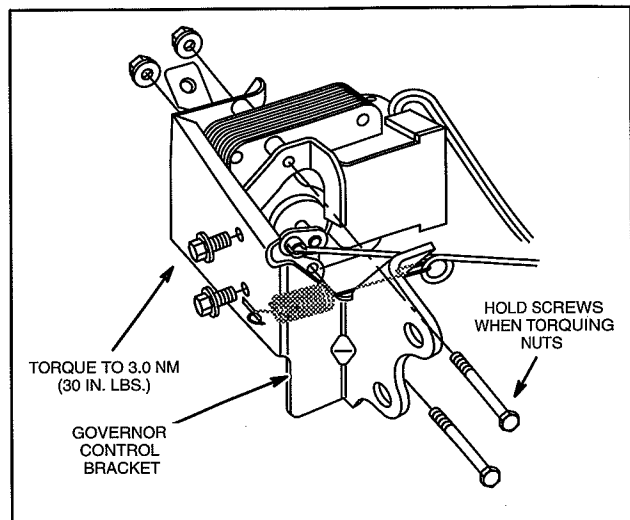
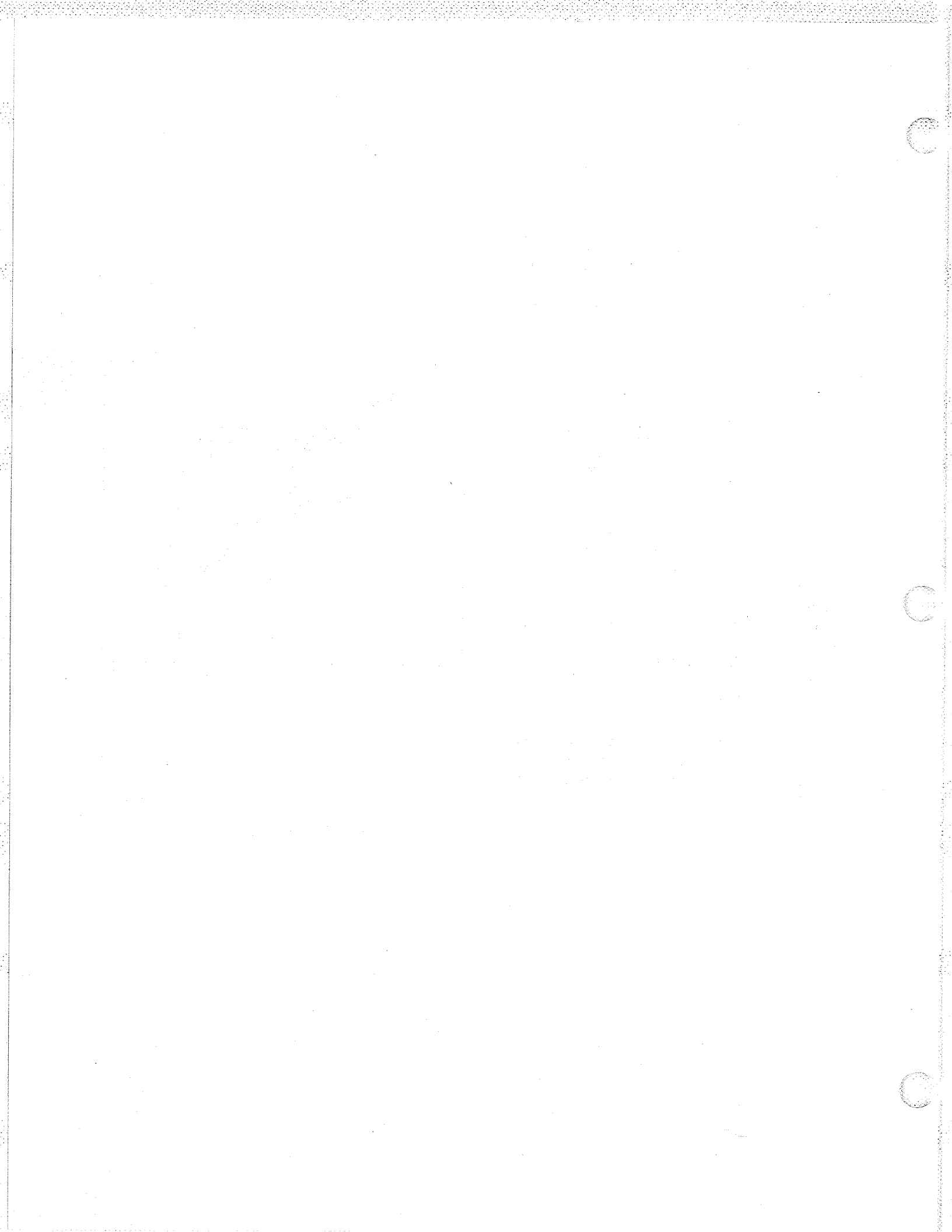

Fig. 36 – Installing Actuator



Section 5

Cylinder Head & Valves

| Section Contents | Page |
|---|------|
| GENERAL INFORMATION | 1 |
| REMOVE CYLINDER HEADS | 1 |
| Rocker Arm Identification | 3 |
| Remove Rocker Arms | 3 |
| DISASSEMBLE CYLINDER HEAD | 4 |
| INSPECT AND REPAIR | 4 |
| Remove Valve Guide | 5 |
| Install Valve Guide | 5 |
| Reface Valves And Seats | 6 |
| ASSEMBLE CYLINDER HEAD | 7 |
| INSTALL CYLINDER HEAD | 7 |
| Install Rocker Arms – Current Style | 8 |
| Install Rocker Arms – Early Style | 8 |
| Install Push Rods | 8 |
| ADJUST VALVE CLEARANCE | 8 |
| REASSEMBLE | 9 |
| STATIC GOVERNOR ADJUSTMENT | 10 |

GENERAL INFORMATION

Compression testing information and procedures is described in "Troubleshooting" in Section 1.

Cylinders and cylinder heads are numbered as shown in Fig. 1.

REMOVE CYLINDER HEADS

Disconnect exhaust system from exhaust manifold. Disconnect choke and throttle control cables. Remove spark plugs.

1. Remove the following parts, Fig. 2.
 - a. Discard gaskets and valve cover seals.

IMPORTANT: MARK COMPONENTS SO THAT THEY MAY BE REASSEMBLED IN THEIR ORIGINAL POSITION.

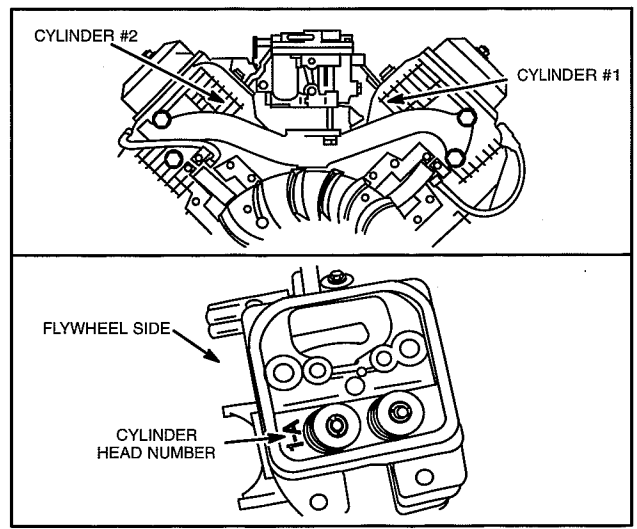

Fig. 1 – Cylinder Identification

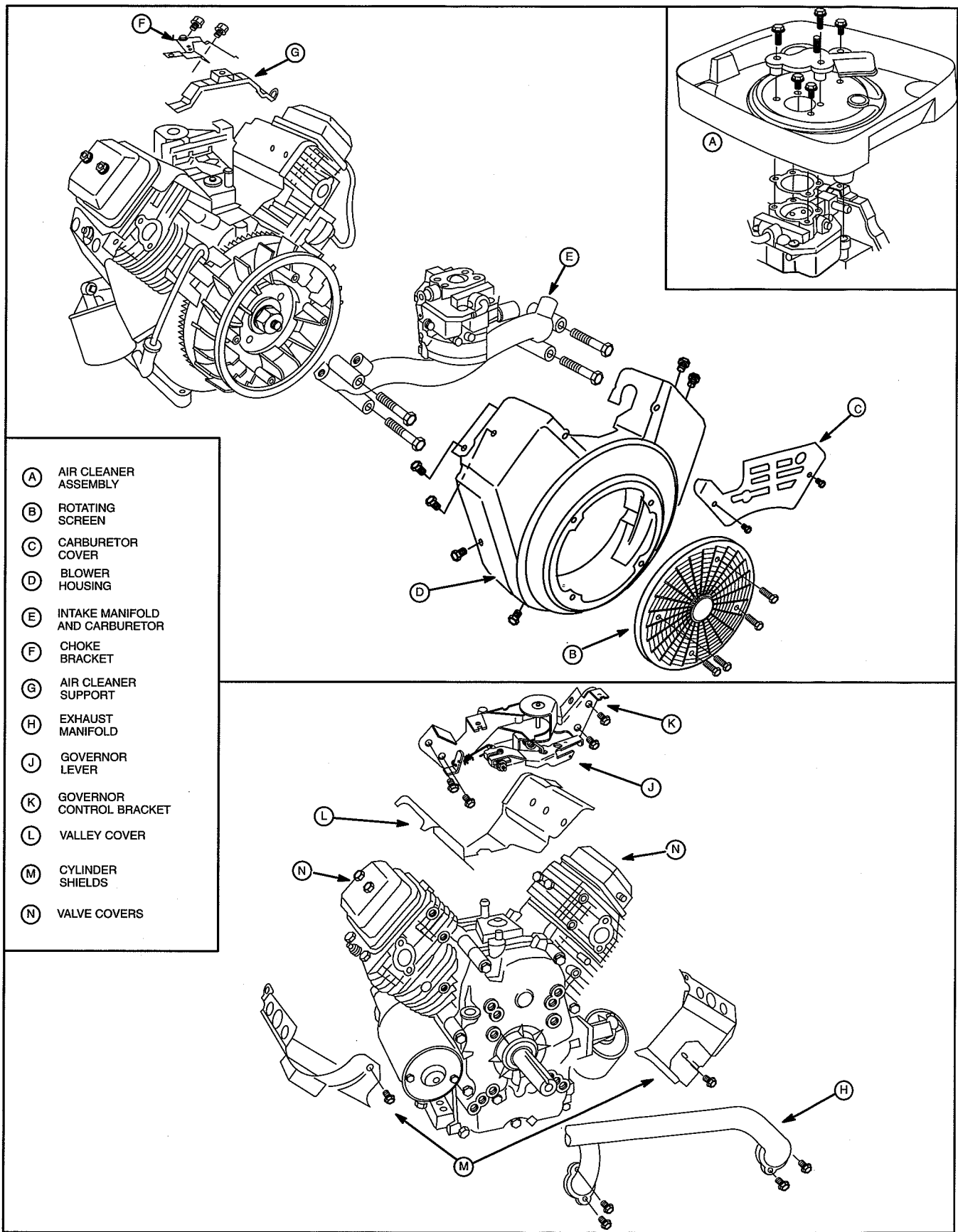

Fig. 2

Rocker Arm Identification

Three different style rocker arms have been used.

Style 3: (Current) Engines manufactured after code date 96033100 are equipped with a redesigned cylinder head, and stamped steel rocker arms with a separate rocker arm support for each valve. The redesigned cylinder head, gasket and rocker arm assembly will not interchange with previous cylinder heads. The only components that are interchangeable with previous cylinder heads are the valves, springs, retainers, keepers, valve stem seals, and valve cover gaskets. The new cylinder head may be used on earlier V-Twins, but only as an assembly. Always refer to code date when ordering parts.

Style 2: Engines manufactured before 96040100 and after 93103100 are equipped with cast aluminum rocker arms with a rocker arm shaft

Style 1: Engines manufactured before code date 93110100 were equipped with stamped steel rocker arms with a rocker arm shaft.

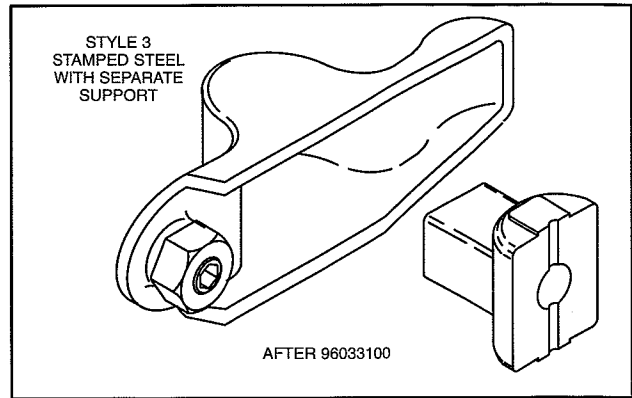

Fig. 3 – Style 3 Rocker Arms

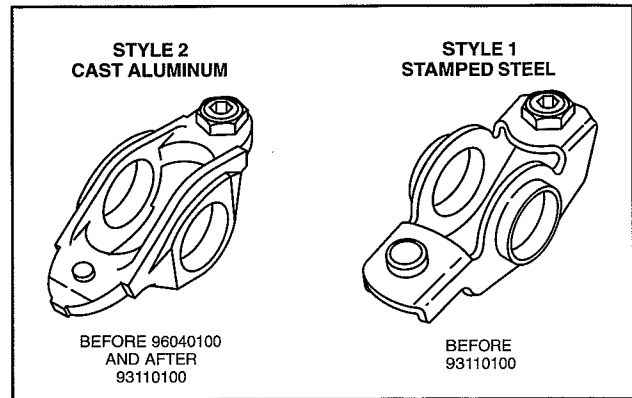

Fig. 4 – Style 2 And Style 1 Rocker Arms

Remove Rocker Arms

1. Remove two rocker studs and rocker arm assembly, Fig. 5 or Fig. 6.
 - a. Remove push rods.

Note: Exhaust valve push rods are aluminum. Mark push rods for identification to prevent interchanging.

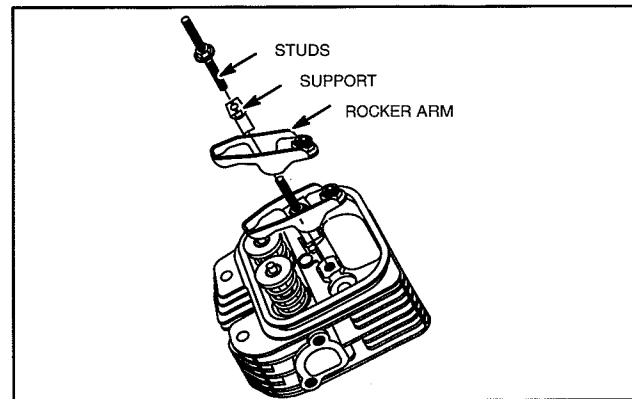

Fig. 5 – Removing Rocker Assembly (Current)

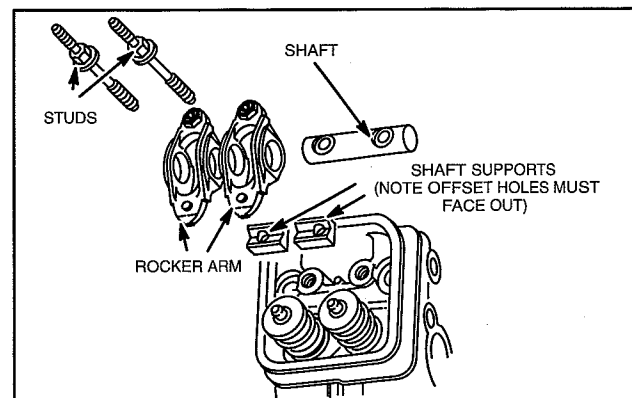

Fig. 6 – Removing Rocker Assembly (Early)

2. Remove head bolts and cylinder head, Fig. 7.
 - a. Discard gasket.

Note: Engines manufactured before 94050100 were equipped with sealing washers under #1 and #3 cylinder head bolts.

Repeat for other cylinder head.

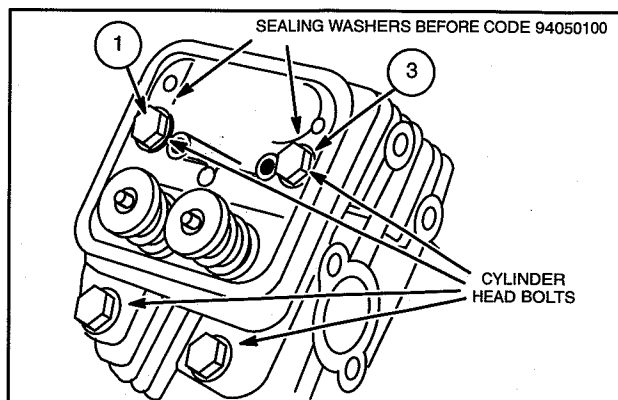

Fig. 7 – Remove Cylinder Head

DISASSEMBLE CYLINDER HEAD

1. Place a shop rag or short section of rubber fuel line under valves inside combustion chamber to hold valve in place while compressing spring.
2. Thread rocker arm support screw into cylinder head a few turns and compress spring with valve spring compressor, Tool #19347, Fig. 8. Remove the following:
 - a. Valve spring retainer locks
 - b. Valve spring retainer
 - c. Valve spring
 - d. IN and EX valve

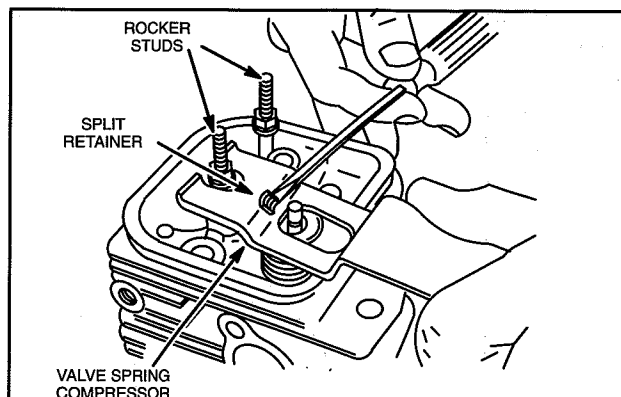

Fig. 8 – Removing Retainers

3. Remove and discard valve stem seals, Fig. 9.

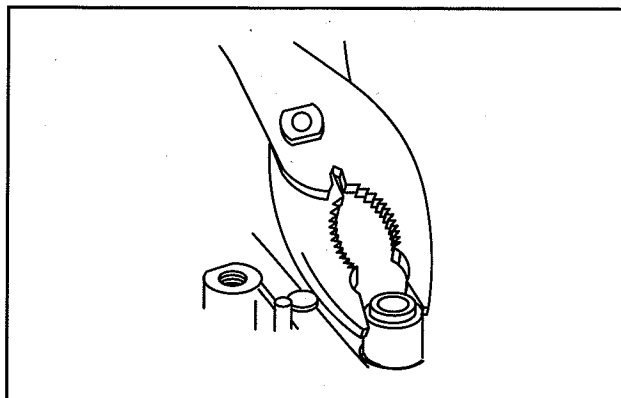

Fig. 9 – Removing Seals

INSPECT AND REPAIR

1. Check cylinder head, Fig. 10.

Be sure all gasket material is removed from surfaces before checking. Use a gasket scraper if necessary.

 - a. Inspect cylinder head for cracks or damage.
 - b. Use a surface plate or straight edge and check cylinder head mounting surface for distortion.

If mounting surfaces are distorted more than 0.1 mm (.004"), the cylinder head must be replaced.

It is not recommended that cylinder head mounting surfaces be resurfaced.

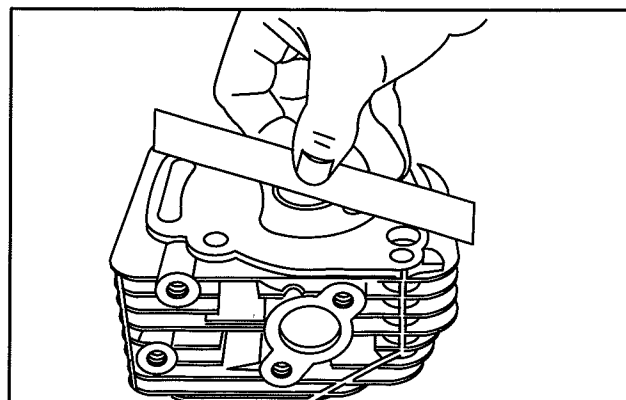

Fig. 10 – Check Cylinder Head Distortion

2. Check valve guide bushings for wear using reject gauge, Tool #19382, Fig. 11.
 - a. Replace valve guide if gauge enters guide 6mm (1/4") or more.

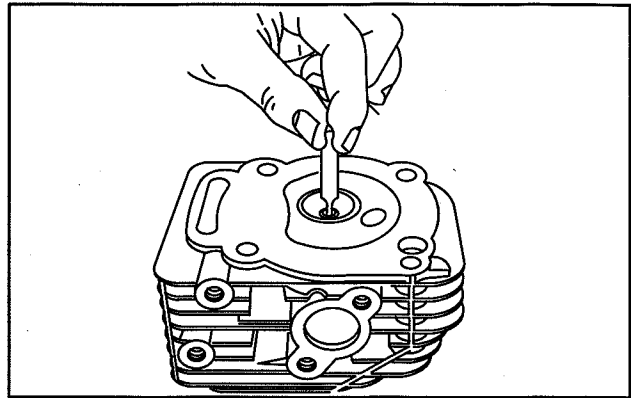

Fig. 11 – Check Valve Guide Bushing

Remove Valve Guide

1. Press out old valve guide using bushing driver, Tool #19367.

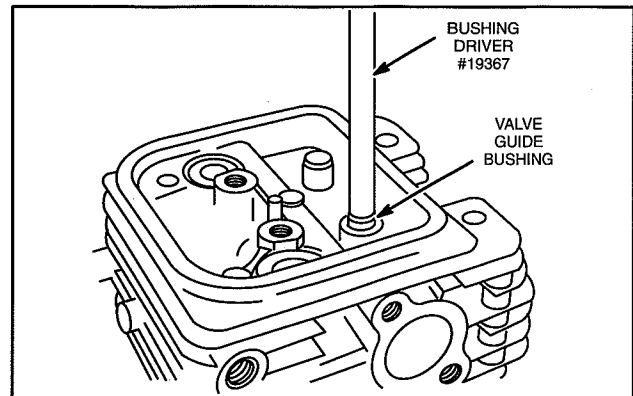

Fig. 12 – Removing Valve Guide

Install Valve Guide

1. Press in new valve guide using bushing driver, Tool # 19416.
 - a. Press in until tool bottoms on valve guide bushing boss.

Do Not use hammer to install bushing.

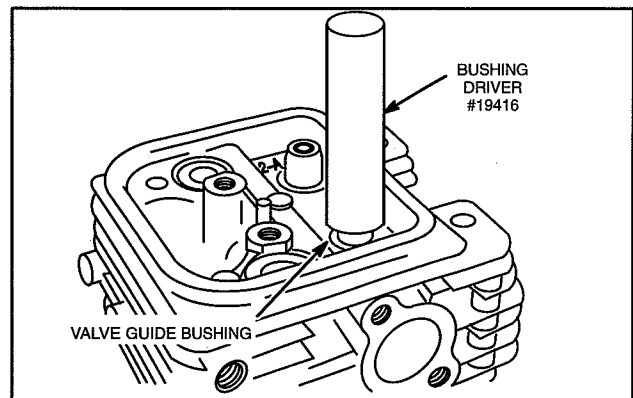

Fig. 13 – Installing Valve Guide

2. Use reamer pilot guide, Tool # 19345 and finish reamer, Tool #19444 and ream new valve guide.
 - a. Use Stanisol® or kerosene to lubricate reamer.
 - b. Ream through entire guide.
 - c. Keep turning reamer clockwise when removing reamer.
 - d. Flush out all chips.

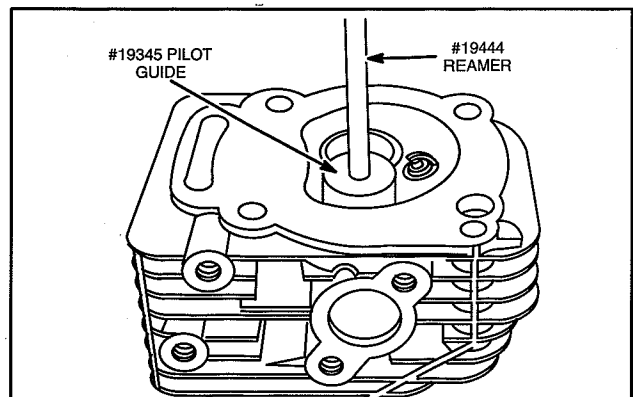

Fig. 14 – Reaming Valve Guide

Reface Valves And Seats

1. Valve seats may be reconditioned using valve seat cutter tool #19237 and #19343.

If valve seat is wider than dimension shown in Fig. 15, a narrowing cutter should be used to ensure that contact area of valve seat is centered on face of valve as shown in Fig. 17.

- a. Use a 60° cutter to narrow seat from bottom and a 15° cutter to narrow seat from top, Fig. 15.

Note: If valve seat is loose or cracked, replace cylinder head.

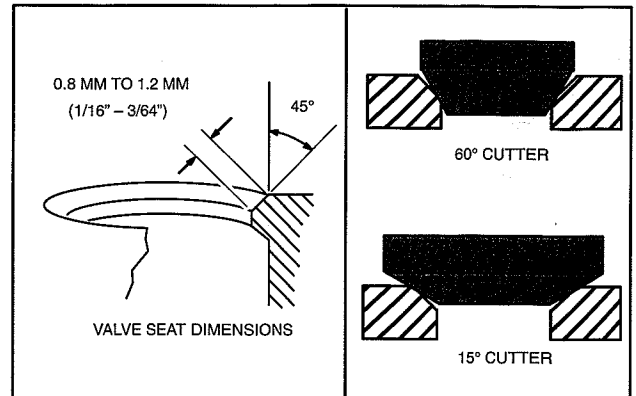

Fig. 15 – Valve Seat Dimensions

2. Measure valve stem diameter at specified distance from end of valve, as shown in Fig. 16.

Replace if less than .233" (5.92 mm).

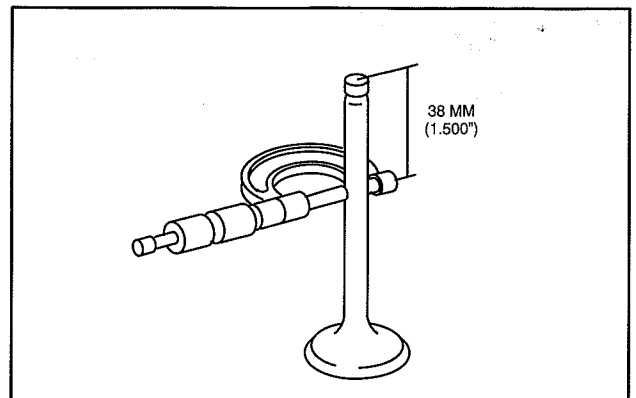

Fig. 16 – Measure Valve Stem Diameter

3. Valve faces may be resurfaced to 45°. See Fig. 17 for dimensions for valves.

4. Lap valves and seats with valve lapping tool, #19258 and valve lapping compound, tool #94150.

Note: In most instances it is more economical to replace the valves than to reface them.

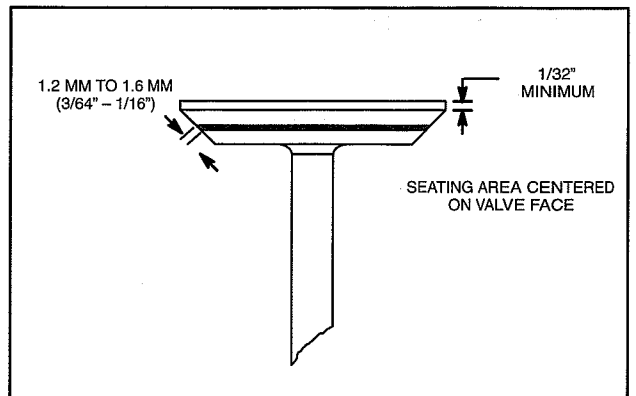

Fig. 17 – Valve Dimensions

5. Check valve springs for free length, Fig. 18.

Replace if free length is less than 41.0 mm (1.614").

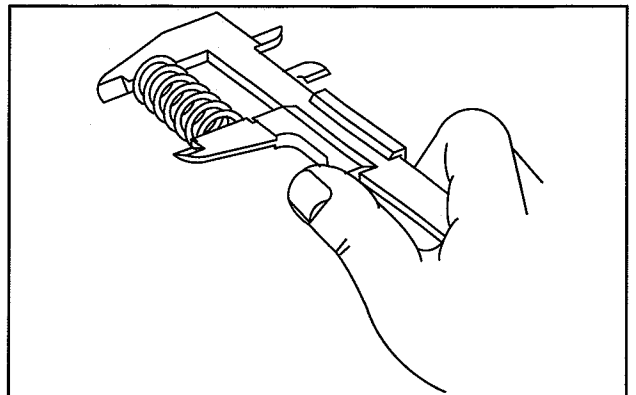

Fig. 18 – Check Valve Springs

ASSEMBLE CYLINDER HEAD

1. Use valve guide driver, Tool #19416 and install new valve stem seals.
 - a. Oil inner surface and lip of valve stem seal.
 - b. Press seal on to valve guide bushing until it bottoms, Fig. 19.

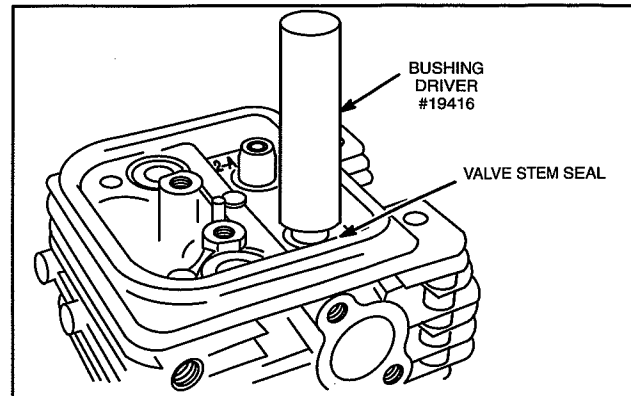

Fig. 19 – Install Valve Seals

2. Install valves, Fig. 20.

Note: Lightly coat valve stems with Valve Guide Lubricant #93963 before installing valves.

Important: Be sure valve guide lubricant is not on valve face, seat or end of valve stem.

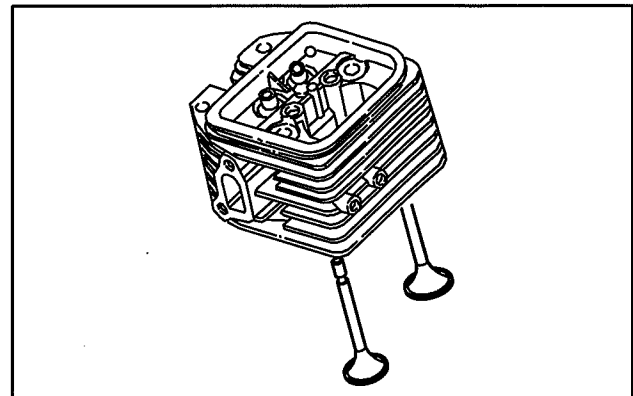

Fig. 20 – Install Valves

3. Place a shop rag or short section of rubber fuel line under valves inside combustion chamber to hold valve in place while compressing spring.
4. Install springs and valve spring retainers over valve stems.
5. Temporarily install rocker studs in cylinder head.
6. Compress valve spring with Tool #19347 and install split retainers, Fig. 21.

Repeat procedure for other valves. Remove rocker studs.

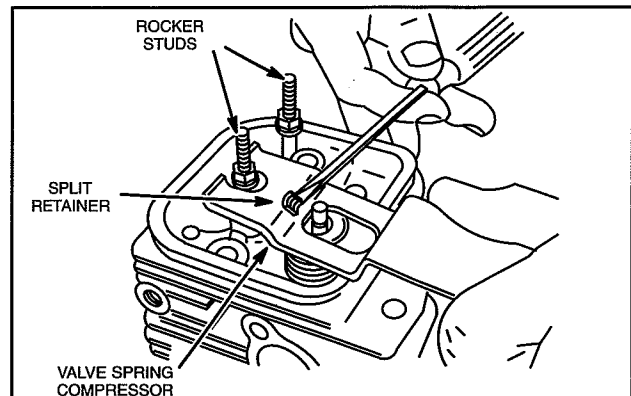

Fig. 21 – Install Retainers

INSTALL CYLINDER HEAD

1. Install cylinder head with new gasket, Fig. 22.

Note: Engines manufactured before 94050100 were equipped with sealing washers under #1 and #3 cylinder head bolts.
2. Lubricate threads of cylinder head screws with Valve Guide Lubricant #93963.
 - a. Torque bolts in sequence shown to 19.0 Nm (165 in. lbs.).
3. Insert push rods into recess in tappets.

Note: Exhaust valve push rods are aluminum.

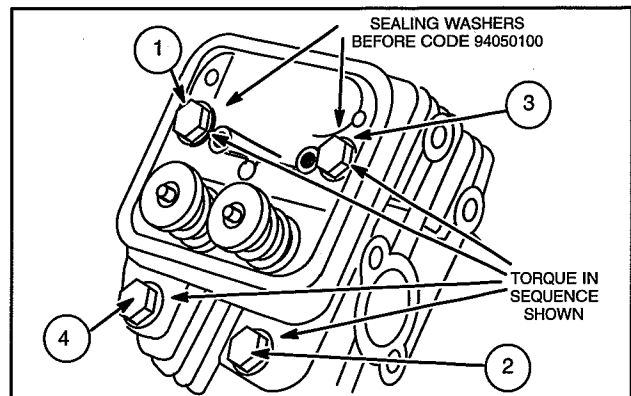

Fig. 22 – Install Cylinder Head

Install Rocker Arms – Current Style

1. Lubricate rocker arm supports with clean engine oil.
2. Assemble rocker studs, rocker arm supports and rocker arms to cylinder head, Fig. 23.
 - a. Torque studs to 11.0 Nm (100 in. lbs.).

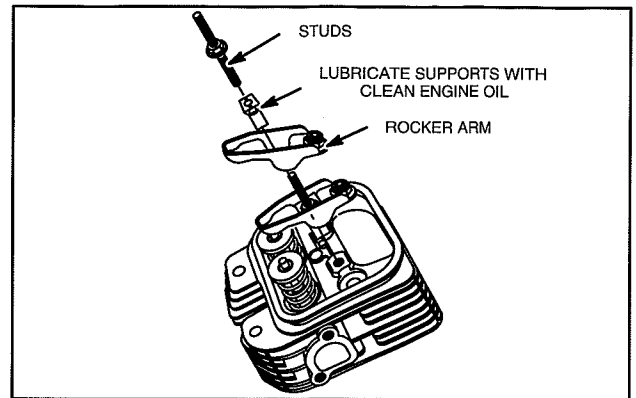

Fig. 23 – Install Rocker Arms – Current Style

Install Rocker Arms – Early Style

Note: Rocker shaft support holes are offset. Install with holes facing ends of rocker shaft, Fig. 24.

1. Lubricate rocker arms and shaft with clean engine oil.
2. Assemble rocker arms, shaft, supports and studs and install on cylinder head, Fig. 24.
 - a. Torque studs to 16.0 Nm (140 in. lbs.).

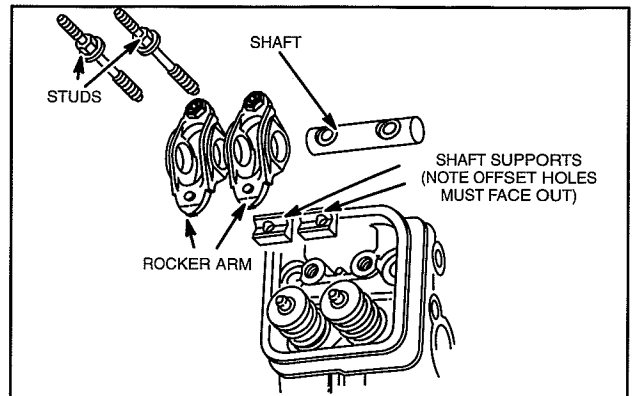

Fig. 24 – Install Rocker Arms – Early Style

Install Push Rods

1. Compress valve spring with rocker arm and insert push rod into rocker arm socket, Fig. 25.
Be sure push rods remain seated in recess in tappets.

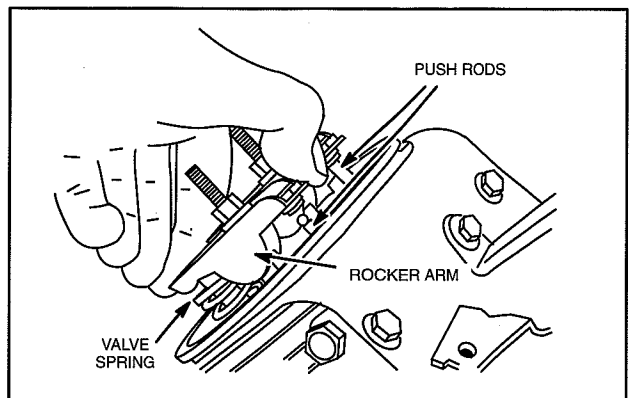

Fig. 25 – Install Push Rods

ADJUST VALVE CLEARANCE

1. Set No. 1 cylinder at 6 mm (1/4") past TDC, compression stroke.
 - a. Adjust valves and check, Fig. 26.

Valve Clearance (cold) IN and EX 0.13 mm (.005").

- b. Torque lock nut and adjusting screw to 7.0 Nm (60 in. lbs.).

2. Repeat for No. 2 cylinder.

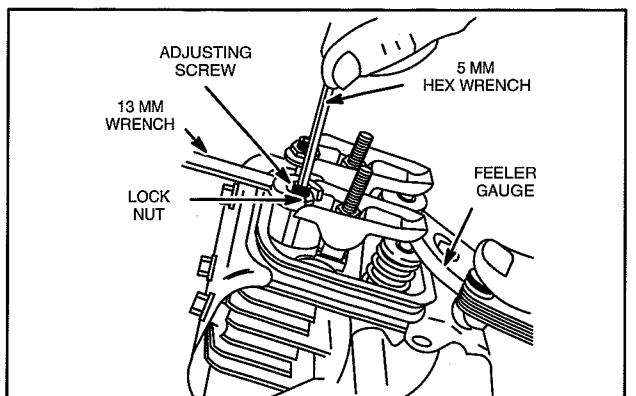

Fig. 26 – Adjust Valve Clearances

3. Install valve covers with new gaskets and valve cover seals, Fig. 27.
 - a. Torque nuts to 3.0 Nm (25 in. lbs.).

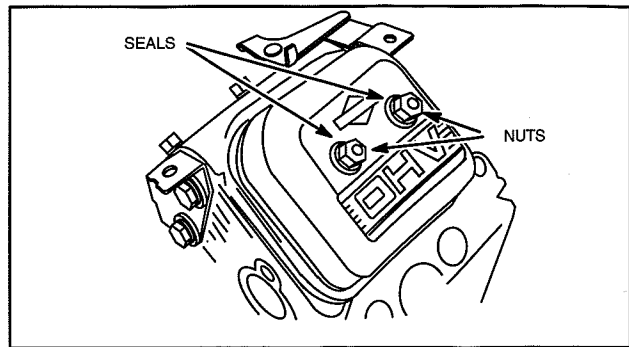

Fig. 27 – Install Valve Covers

REASSEMBLE

1. Install cylinder shields and valley cover.
 - a. Torque screws to 7.0 Nm (65 in. lbs.).
2. Assemble governor lever to governor shaft. DO NOT tighten nut at this time.
3. Install governor control bracket
 - a. Torque screws to 16.0 Nm (140 in. lbs.).
4. Install exhaust manifold.
 - a. Torque screws to 16.0 Nm (140 in. lbs.).

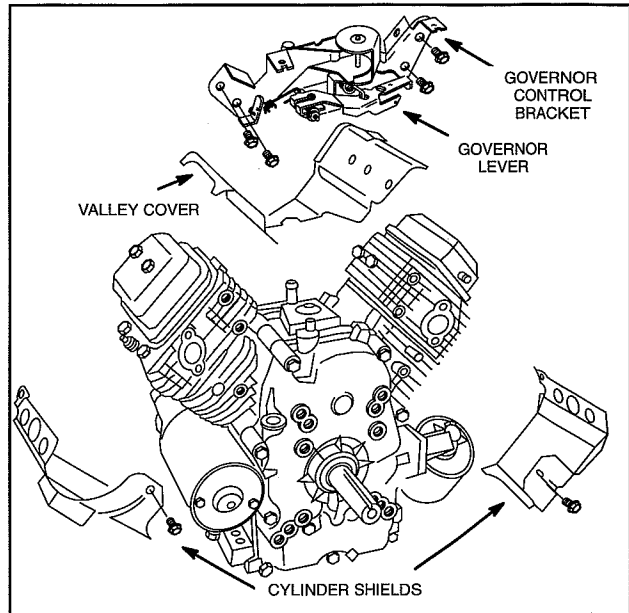

Fig. 28 – General Assembly

5. Install air cleaner support and choke bracket.
 - a. Torque screws to 7.0 Nm (65 in. lbs.).
6. Install intake manifold with new gaskets.
 - a. Torque screws to 16.0 Nm (140 in. lbs.).
 - b. Assemble governor link and spring to carburetor.

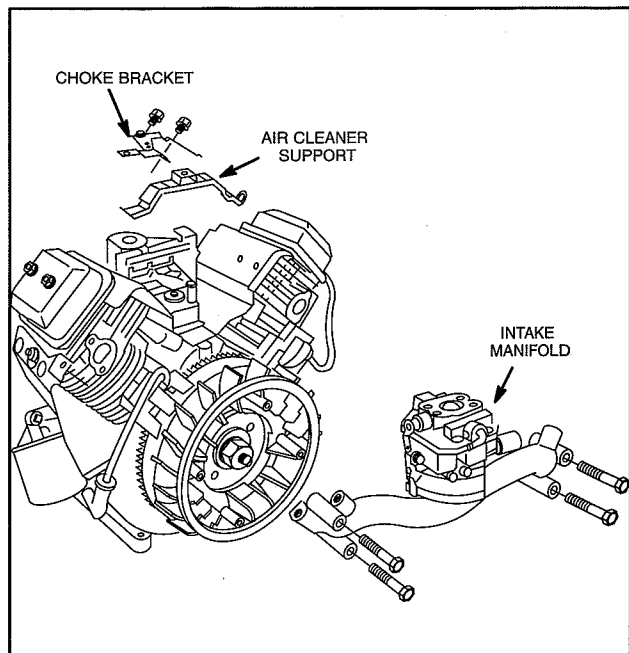

Fig. 29 – General Assembly

7. Install blower housing.
 - a. Torque 6 mm screws to 7.0 Nm (65 in. lbs.).
 - b. Torque 8 mm screws to 16.0 Nm (140 in. lbs.).
8. Install carburetor cover.
9. Install rotating screen.

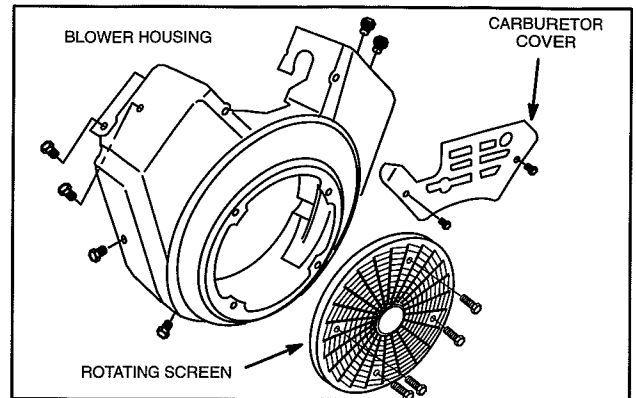

Fig. 30 – Install Blower Housing

10. Install air cleaner base with new mounting gasket.
 - a. Torque screws to 7.0 Nm (65 in. lbs.).
11. Assemble air cleaner.
12. Install spark plugs.
 - a. Torque spark plugs to 23.0 Nm (200 in. lbs.).

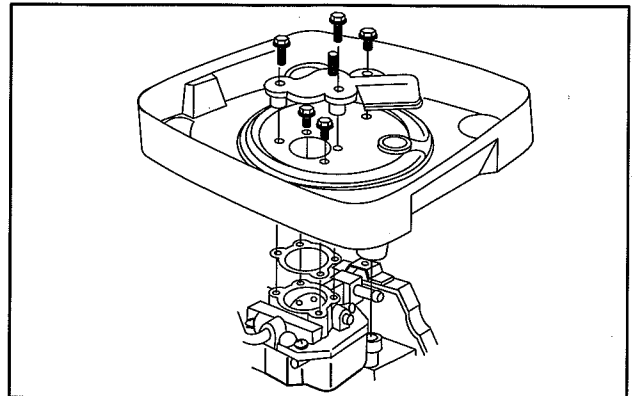

Fig. 31 – Install Air Cleaner Base

WARNING: BEFORE STARTING OR RUNNING ENGINE, STATIC ADJUSTMENT OF THE GOVERNOR MUST BE COMPLETED! FAILURE TO MAKE THE STATIC ADJUSTMENTS FIRST COULD RESULT IN ENGINE OVERSPEEDING WHICH MAY RESULT IN ENGINE DAMAGE, PROPERTY DAMAGE OR PERSONAL INJURY.

STATIC GOVERNOR ADJUSTMENT

1. With governor lever nut loose, push on governor lever until throttle is wide open. **Do not bend governor link or distort governor lever.**
2. Rotate governor shaft counter-clockwise as far it will go, Fig. 16.
 - a. Torque governor nut to 8.0 Nm (70 in. lbs.).
3. Install throttle and choke control cables and check for proper operation.

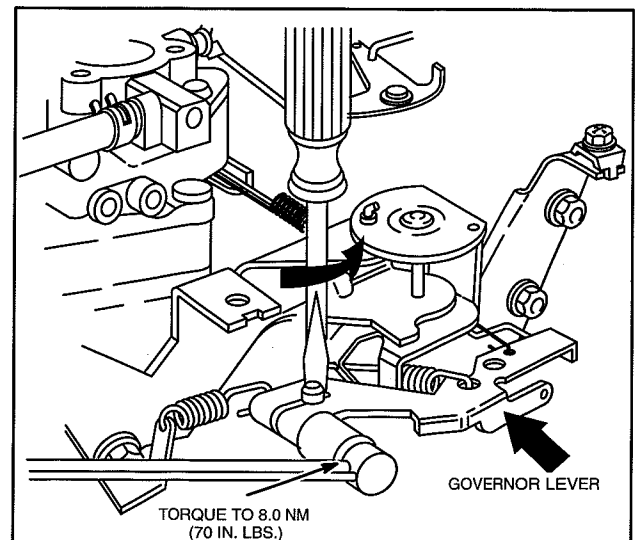

Fig. 32 – Static Governor Adjustment

Section 6A

Rewind Starters

| Section Contents | Page |
|--|----------|
| STARTER IDENTIFICATION | 2 |
| REMOVE STARTER – BOTH STYLES | 2 |
| Remove Rope – Both Styles | 3 |
| Winding Spring – Current Style | 3 |
| Winding Spring – Early Style | 3 |
| Install Rope – Both Styles | 3 |
| REMOVE PULLEY AND SPRING – CURRENT STYLE | 4 |
| Inspect Starter Housing And Pulley | 5 |
| Assemble Pulley To Housing | 5 |
| Install Dogs, Dog Springs And Retainer | 6 |
| REPLACE STARTER SPRING – EARLY STYLE | 6 |
| Remove Pulley And Spring | 6 |
| Inspect Spring, Starter Housing And Pulley | 7 |
| Install Spring, Cup Assembly And Pulley In Starter Housing | 8 |
| Install Dogs, Dog Springs And Retainer | 9 |
| INSTALL REWIND STARTER | 9 |

6A

STARTER IDENTIFICATION

Two different rewind starters are used on V-Twin engines. The current style starter along with the starter cup are not interchangeable with the early style starter and cup. Also, the rewind starter components are not interchangeable. Fig. 1 shows how to identify the current style rewind starter from the early style.

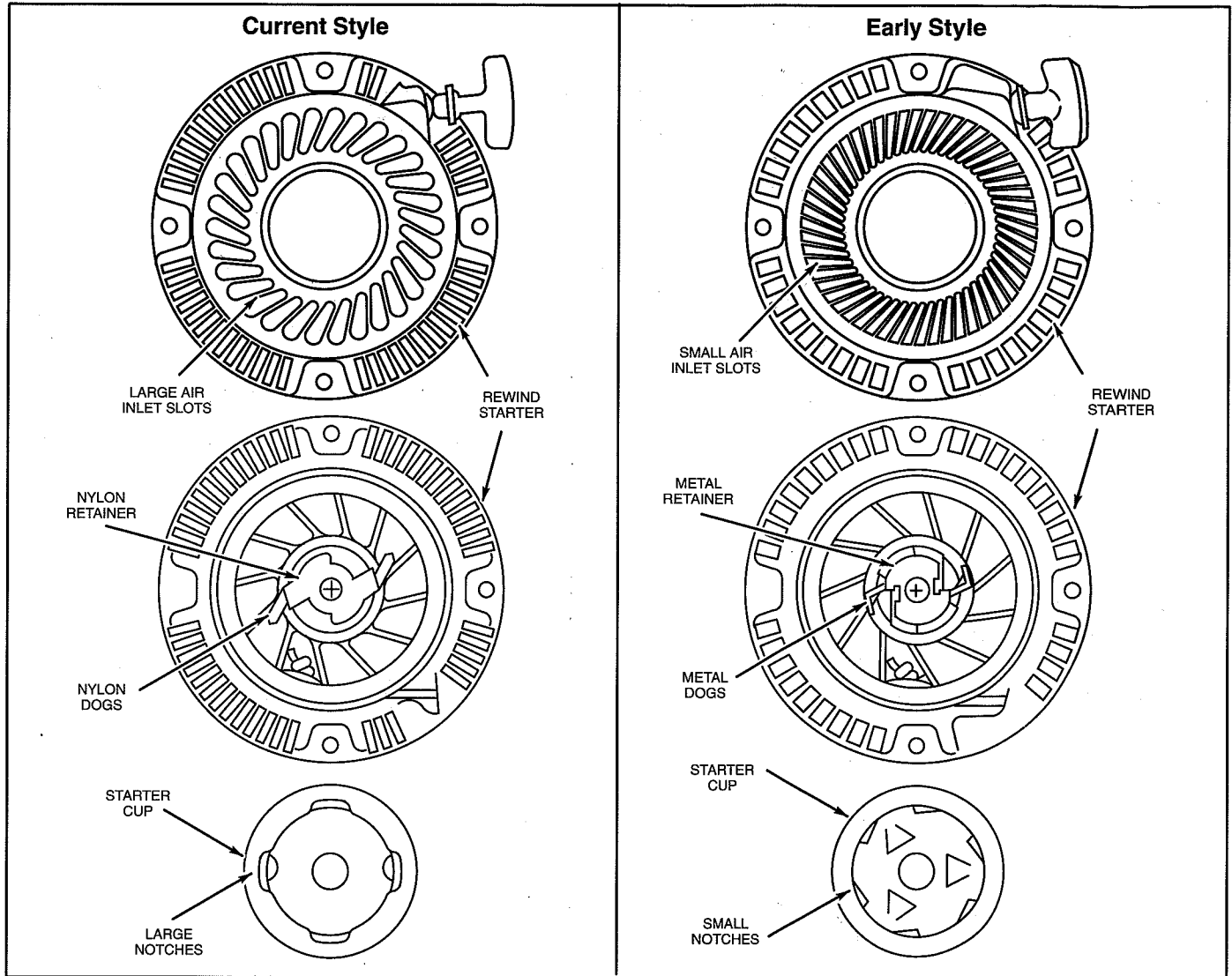

Fig. 1 - Starter Identification

REMOVE STARTERS - BOTH STYLES

Remove four screws and rewind starter, Fig. 2.

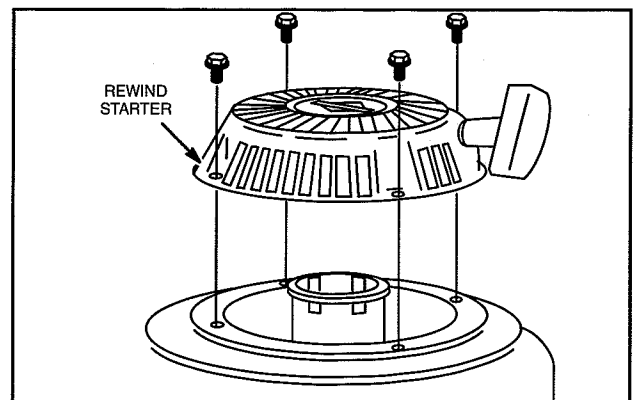

Fig. 2 - Remove Rewind Starter

Remove Rope – Both Styles

1. Pull rope out part way and tie a temporary knot.
2. Remove rope insert from rope handle, and pull knot out of rope insert.
3. Untie knot and remove insert and handle from rope, Fig. 3.
4. Pull rope out as far as it will go.
5. While holding rewind pulley, grasp knot with a pair of needle nose pliers and pull rope out of pulley.
6. Slowly release spring tension on pulley until pulley stops turning.

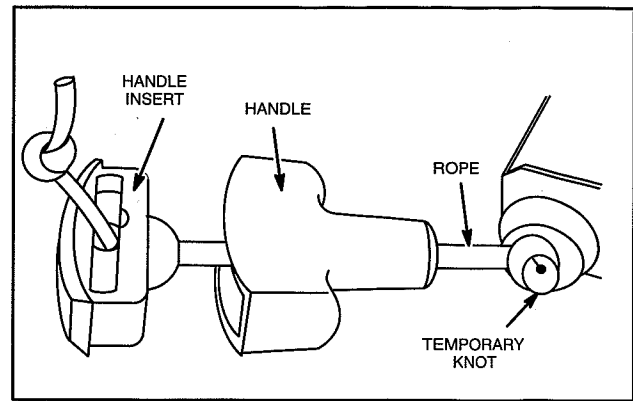

Fig. 3 – Remove Handle And Insert

Important: See illustrated parts list for correct replacement rope for style starter. Replacement rope must be cut to length shown.

Current Style Starter 200 cm (80")
Early Style Starter 178 cm (70")

1. After cutting rope, heat end with an open flame and wipe with a rag to prevent unraveling.
 2. Tie a figure eight knot at one end of rope, Fig. 4.
- THE CURRENT STYLE STARTER REQUIRES A DIFFERENT PROCEDURE FOR WINDING THE SPRING THAN THE EARLY STYLE STARTER.

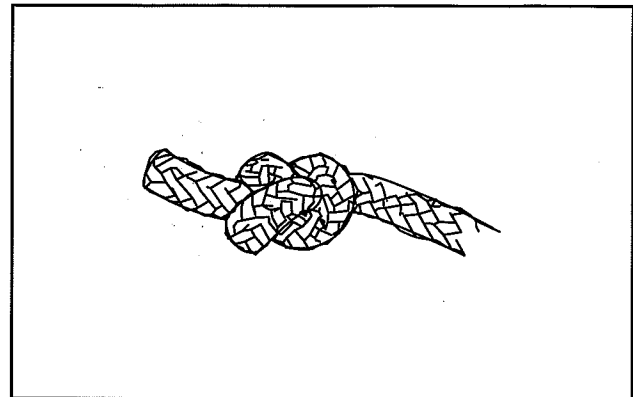

Fig. 4 – Tie Figure Eight Knot

Winding Spring – Current Style

1. Rotate pulley COUNTERCLOCKWISE SIX (6) complete turns.
2. Then rotate pulley clockwise until rope hole in pulley is in line with starter housing eyelet.
3. Hold pulley in this position, Fig. 5.

Winding Spring – Early Style

1. Rotate pulley COUNTERCLOCKWISE until spring is WOUND TIGHT.
2. Then rotate pulley clockwise until rope hole in pulley is in line with starter housing eyelet.
3. Hold pulley in this position, Fig. 5.

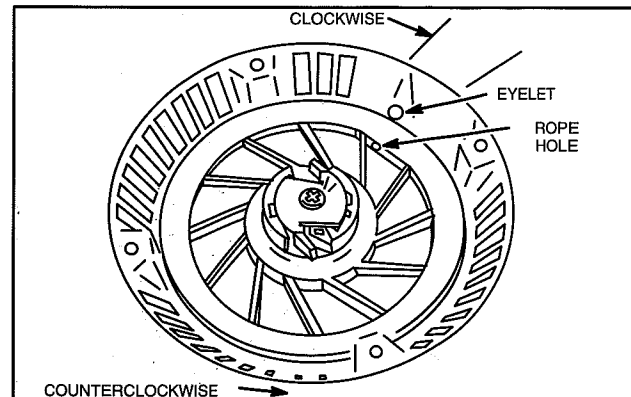

Fig. 5 – Winding Spring

Install Rope – Both Styles

1. Insert rope through pulley and eyelet in housing, Fig. 6.
2. Pull rope until knot is seated.
3. While still holding pulley, tie a temporary knot part way out on rope.
4. Let pulley and spring slowly rewind pulling rope into temporary knot.

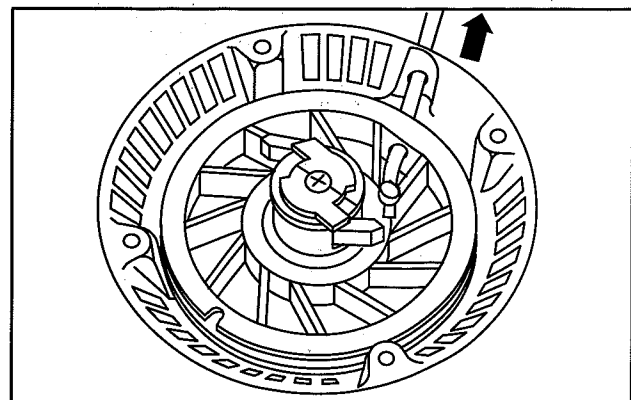

Fig. 6 – Install Rope

5. Insert rope through starter rope handle and starter rope insert, Fig. 7.
6. Tie knot on end of rope, Fig. 7.
7. Pull knot into rope insert and pull insert into rope handle.
8. Untie temporary knot and slowly let rope rewind into starter.
9. Operate starter to check for smooth operation.

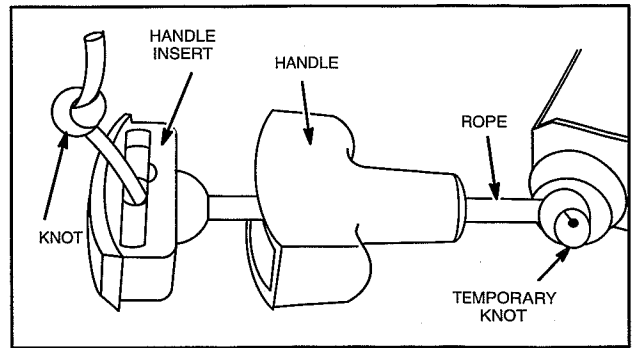

Fig. 7 – Install Handle

REMOVE PULLEY AND SPRING ASSEMBLY– CURRENT STYLE



CAUTION: PULLEY AND SPRING IS SERVICED AS AN ASSEMBLY. DO NOT REMOVE SPRING FROM PULLEY.



WARNING: THE STARTER SPRING IS STILL UNDER TENSION WHEN THE ROPE HAS BEEN REMOVED AND THE PULLEY HAS NO SPRING TENSION AGAINST IT. WEAR EYE PROTECTION TO PREVENT EYE INJURY WHEN REMOVING AND INSTALLING STARTER PULLEY AND SPRING ASSEMBLY.

1. Remove rope.
2. Remove shoulder screw and retainer, Fig. 8.
3. Lift out dogs and dog springs.

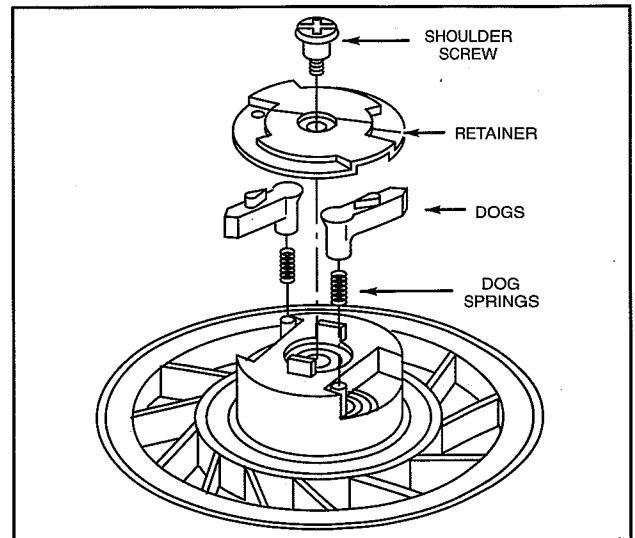

Fig. 8 – Remove Retainer – Current Style

4. Rotate pulley clockwise until pulley disengages spring.
5. Carefully lift out pulley with spring, Fig. 9.

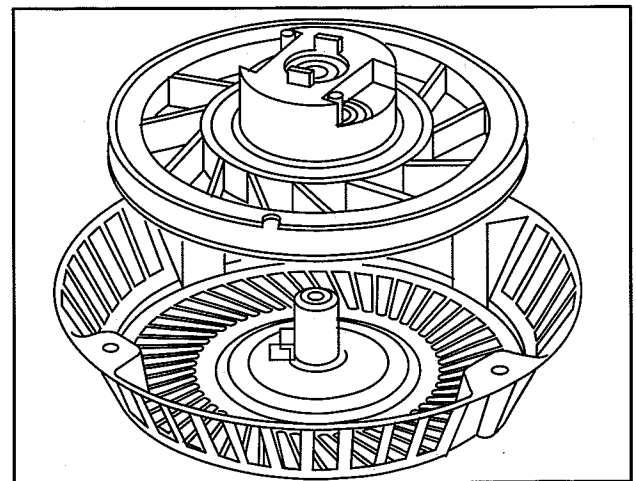

Fig. 9 – Remove Pulley And Spring

Inspect Starter Housing and Pulley

Inspect pulley for wear, cracks, rough edges or burrs in pulley groove and wear on center hole, Fig. 10. Replace pulley if damaged or worn.

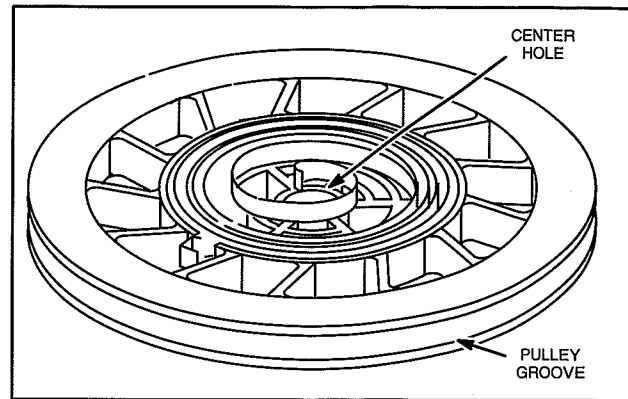

Fig. 10 – Inspect Pulley – Current Style

Inspect starter housing for wear or sharp edges at rope eyelet, center pivot post, and inner spring anchor tab, Fig. 11. Replace housing if worn or damaged.

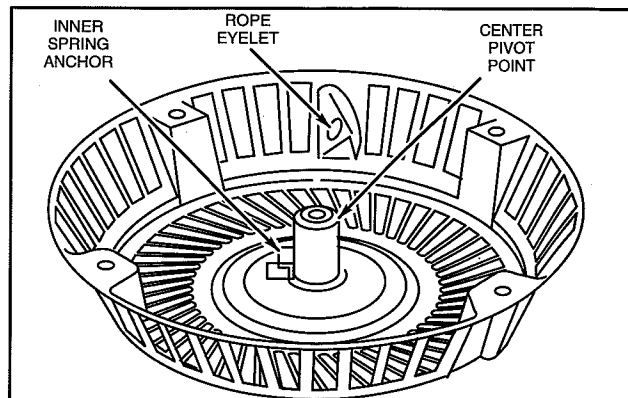

Fig. 11 – Inspect Housing – Current Style

Assemble Pulley To Housing

1. Lay starter housing on work bench.
2. Assemble starter pulley and spring assembly to center pivot post in housing, Fig. 12.

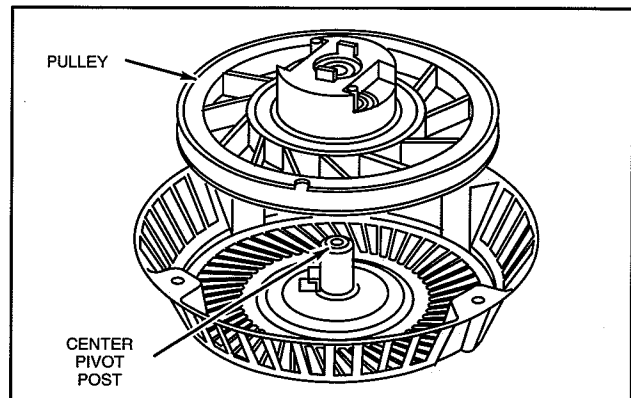

Fig. 12 – Install Pulley – Current Style

3. Rotate pulley counter clockwise until slight resistance is felt, indicating that spring is engaged in spring tab in housing, Fig. 13.

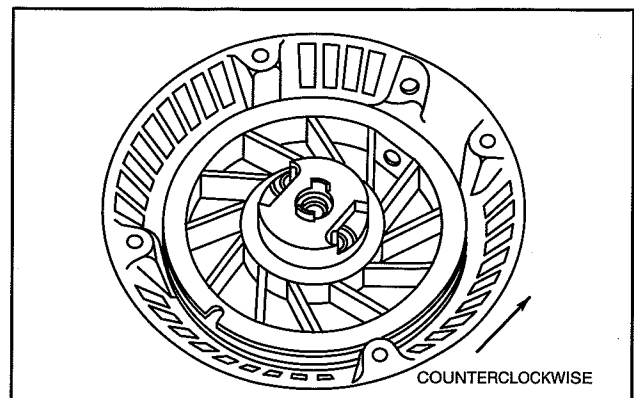

Fig. 13 – Engage Spring – Current Style

6A

Install Dogs, Dog Springs, And Retainer Assembly

1. Position springs over posts in pulley.
 - a. Install dogs, Fig. 14.

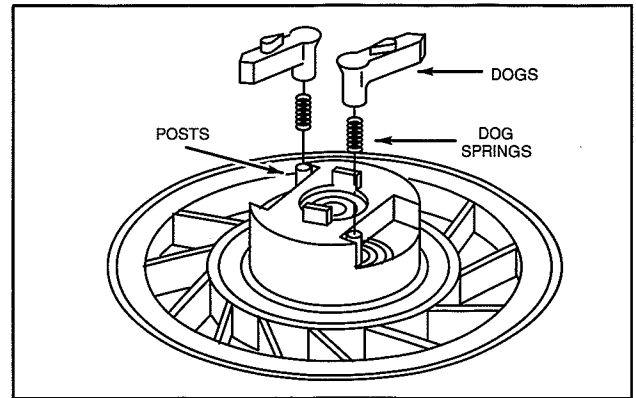

Fig. 14 – Install Dogs And Springs – Current Style

2. Install retainer making sure that slots in retainer engage tabs on pulley, Fig. 15.
3. Hold retainer down, compressing dog springs and install retainer screw.
 - a. Torque screw to 8.0 Nm (70 in. lbs.).

Install rope.

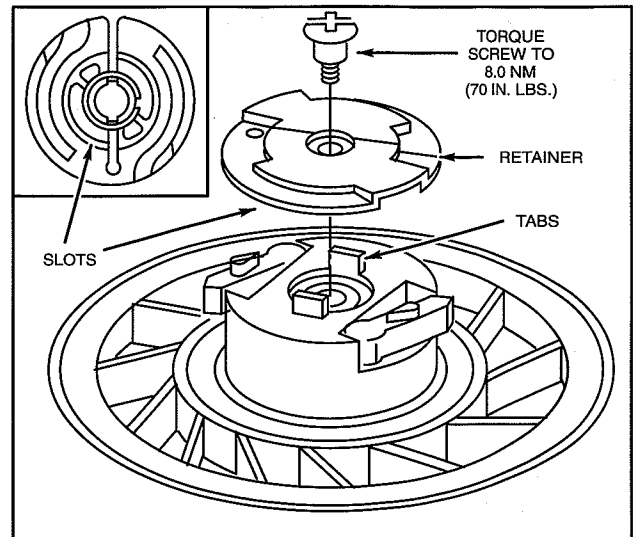

Fig. 15 – Install Retainer – Current Style

REPLACE STARTER SPRING – EARLY STYLE



WARNING: THE STARTER SPRING IS STILL UNDER TENSION WHEN THE ROPE HAS BEEN REMOVED AND THE PULLEY HAS NO SPRING TENSION AGAINST IT. WEAR EYE PROTECTION TO PREVENT EYE INJURY WHILE DISASSEMBLING AND REASSEMBLING STARTER PULLEY AND SPRING.

Remove Pulley And Spring

1. Remove rope.
2. Remove shoulder screw, small washer, retainer, brake spring and large washer, Fig. 16.

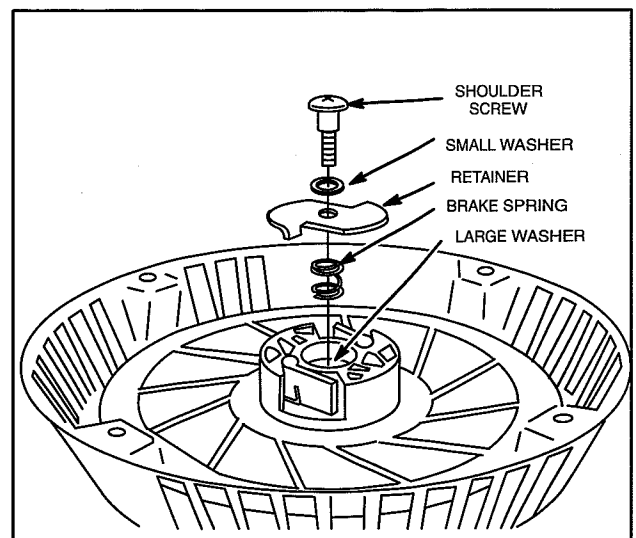

Fig. 16 – Remove Retainer – Early Style

3. Lift out dogs and dog springs.
4. Rotate pulley until pulley disengages spring.
5. Carefully lift out pulley, Fig. 17.

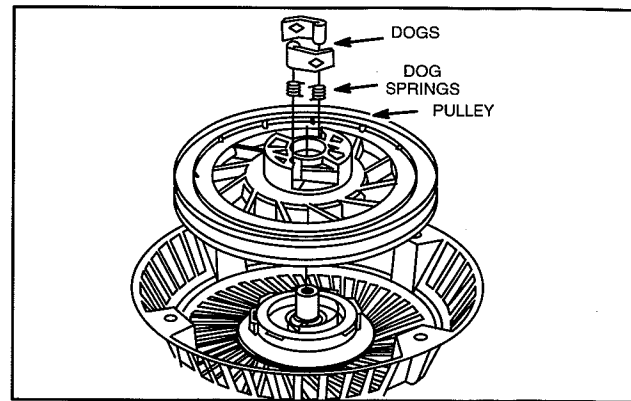

Fig. 17 – Remove Pulley – Early Style

The starter spring and cup will normally remain as an assembly in starter housing.

6. Remove spring and cup assembly from starter housing, Fig. 18.



CAUTION: SPRING AND CUP ARE SERVICED AS AN ASSEMBLY. DO NOT ATTEMPT TO REMOVE SPRING FROM CUP.

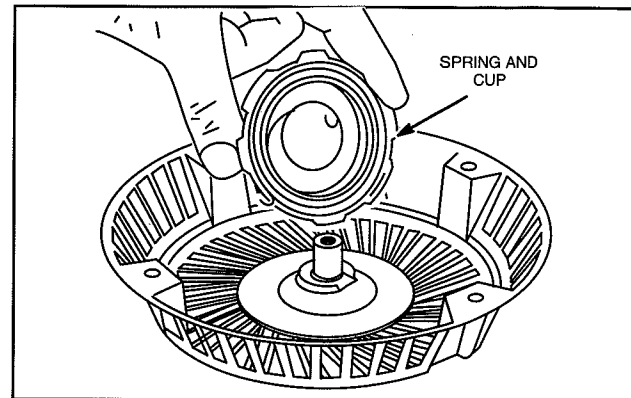

Fig. 18 – Remove Spring Assembly – Early Style

Inspect Spring, Starter Housing and Pulley

Inspect pulley for cracks, rough edges or burrs in pulley groove, wear on spring cup lugs, and wear on center hole, Fig. 19. Replace pulley if damaged or worn.

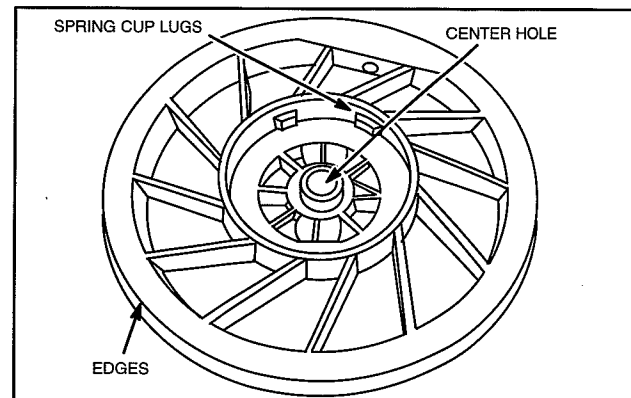

Fig. 19 – Inspect Pulley – Early Style

Inspect starter housing for wear and sharp edges at rope eyelet, center pivot post, and at inner spring anchor, Fig. 20. Replace if worn or damaged.

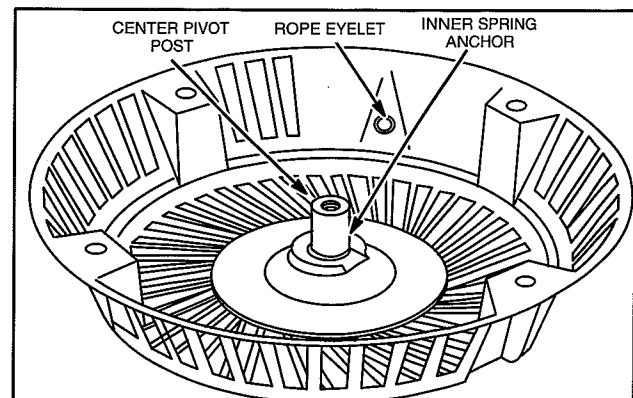

Fig. 20 – Inspect Housing – Early Style

6A

Install Spring, Cup Assembly and Pulley In Starter Housing

1. Place spring and cup assembly in pulley with outer end of spring tab between two wide lugs in pulley and spring cup projections next to the two wide lugs, Fig. 21.

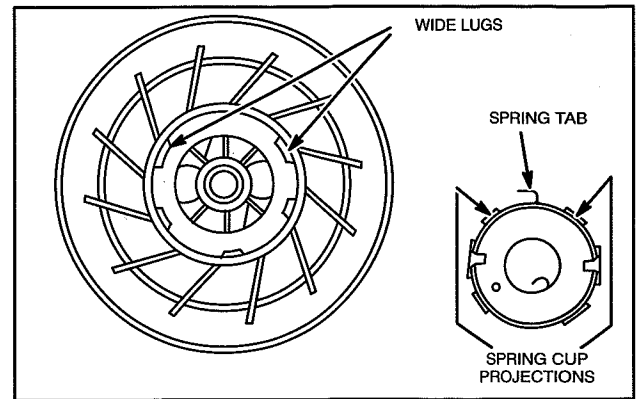

Fig. 21 – Install Spring Assembly – Early Style

2. Note location of spring tab and location of spring anchor on center post of starter housing.
3. Lower starter housing onto pulley and spring assembly, Fig. 22.

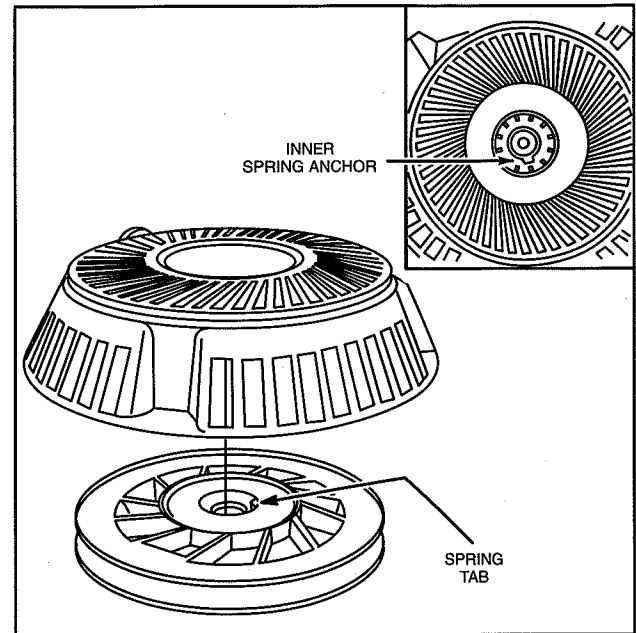

Fig. 22 – Install Pulley – Early Style

4. Invert assembly, rotate pulley counterclockwise until inner spring tab engages spring anchor, Fig. 23.

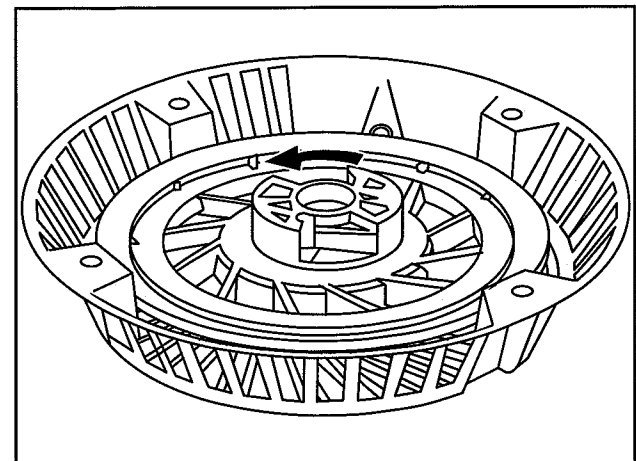

Fig. 23 – Engage Spring – Early Style

Install Dogs, Dog Springs, And Retainer Assembly

1. Install dogs and dog springs in pulley, Fig. 24.

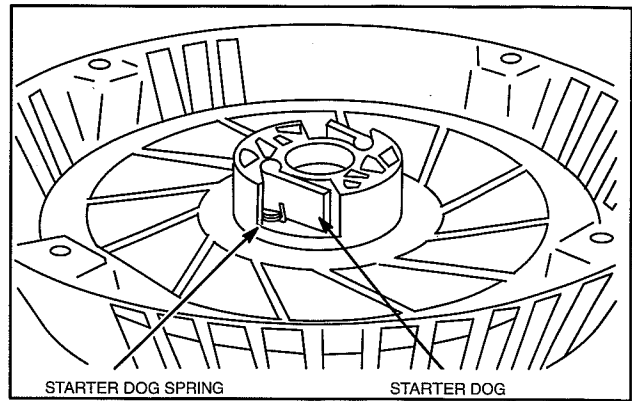

Fig. 24 – Install Dogs And Springs – Early Style

2. Place large washer, brake spring and retainer on pulley.
3. Place small washer on shoulder screw and install screw and washer in center pivot post, Fig. 25.
4. Position tabs of retainer inside dogs.
 - a. Torque screw to 8.0 Nm (70 in. lbs.).

Install rope.

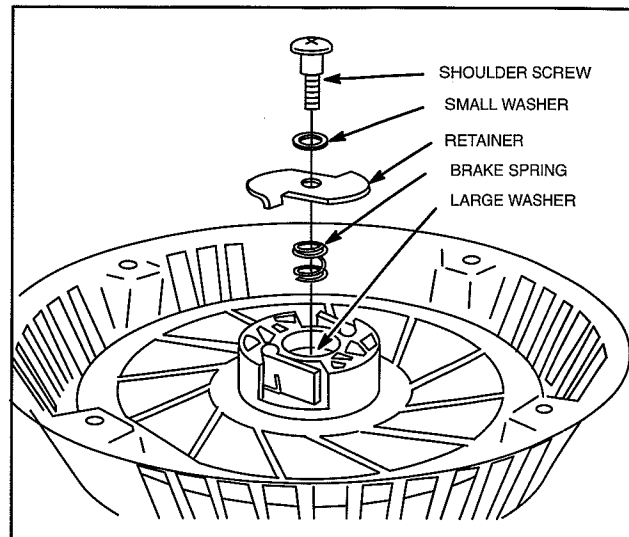

Fig. 25 – Install Retainer – Early Style

INSTALL REWIND STARTER

1. Install rewind starter on blower housing and install screws finger tight, Fig. 26.
2. Pull rope to engage dogs in starter cup.
3. While holding rope, tighten screws to 7.0 Nm (60 in. lbs.).

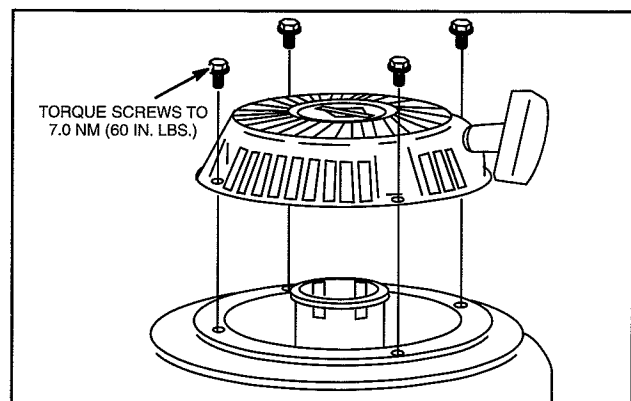
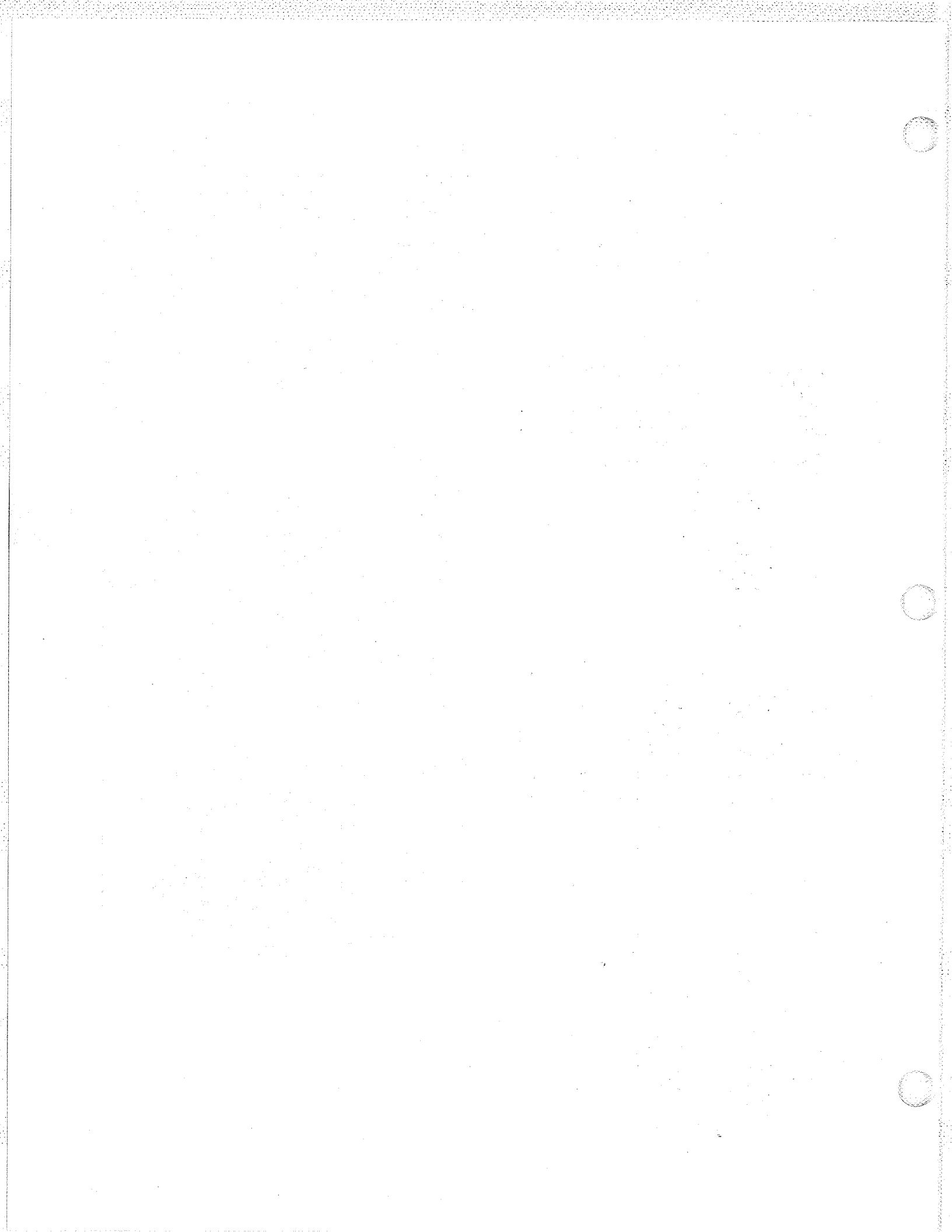

Fig. 26 – Install Starter

6A



Section 6B

Electric Starters

| Section Contents | Page |
|---|------|
| GENERAL INFORMATION | 2 |
| TROUBLESHOOTING | 2 |
| TEST EQUIPMENT | 3 |
| TEST STARTER MOTOR | |
| Remove Starter Motor | 4 |
| Testing Starter Motor | 4 |
| Starter Motor Specifications | 4 |
| Conditions Affecting Starter Motor Performance | 4 |
| STARTER DRIVE | |
| Checking Starter Motor Drive | 5 |
| Disassemble Starter Drive – C-Ring Style | 5 |
| Assemble Starter Drive – C-Ring Style | 6 |
| Disassemble Starter Drive – Roll Pin Style | 5 |
| Assemble Starter Drive – Roll Pin Style | 6 |
| Disassemble Starter Drive – Steel Pinion | 7 |
| Inspect Starter Drive – Steel Pinion | 7 |
| Assemble Starter Drive – Steel Pinion | 7 |
| DISASSEMBLE STARTER MOTOR | 7 |
| Inspect Armature Commutator | 8 |
| Inspect Brushes | 8 |
| Replace Brushes | 8 |
| ASSEMBLE STARTER | |
| Assemble End Cap – Radial Flat Coil Type Brush Spring | 9 |
| Assemble End Cap – Radial Type Brush Spring | 9 |
| Assemble End Cap – Axial Type Brush Spring | 9 |
| Assemble Armature | 10 |
| Assemble Housing | 10 |
| Install Drive End Cap | 10 |
| INSTALL STARTER MOTOR | 10 |
| REPLACE RING GEAR | 11 |
| ELECTRIC STARTER PANEL KIT WITH ROTARY KEY SWITCH AND SOLENOID | |
| Testing Key Switch | 11 |
| Testing Starter Solenoid | 13 |
| Wiring Diagram | 12 |
| BATTERY INFORMATION | |
| Installation | 13 |
| Checking Battery | 14 |
| Testing Battery | 14 |
| Battery Recommendations | 14 |
| Battery Cable Recommendations | 14 |

6B

GENERAL INFORMATION

The starter motor uses a gear type engagement method, similar to an automobile starter. When the starter motor is activated, the pinion gear engages a ring gear attached to the engine flywheel and cranks the engine.

Two style starter motors are used on Vanguard™ V-twin engines, Fig. 1 and Fig. 2.

Nylon Pinion

The starter motor shown in Fig. 1 has a nylon type pinion gear and is used only on flywheels equipped with an aluminum ring gear. The flywheel ring gear is replaceable. See page 10.

Steel Pinion

The starter motor shown in Fig. 2 has a steel pinion gear and is used only with flywheels equipped with a steel ring gear. The flywheel ring gear is NOT replaceable.

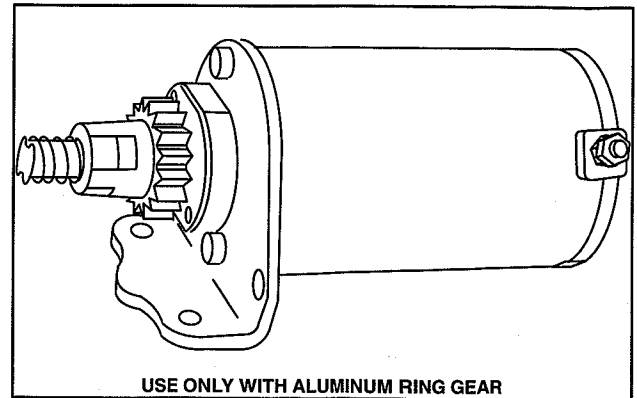

Fig. 1 – Nylon Pinion Starter Motor

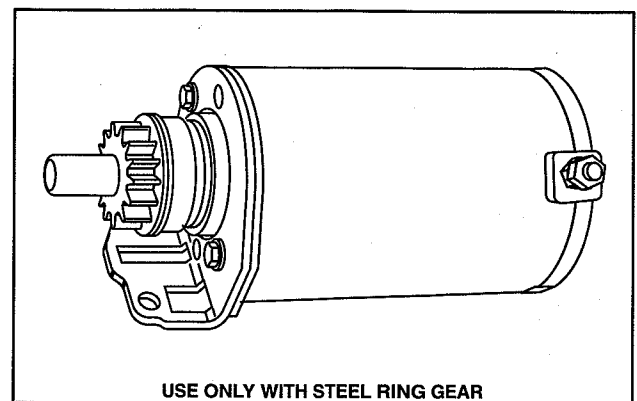

Fig. 2 – Steel Pinion Starter Motor

6B

TROUBLESHOOTING

If a starting problem is encountered, the engine itself should be thoroughly checked to eliminate it as the cause of starting difficulty. It is a good practice to check the engine for freedom of rotation by removing the spark plugs and turning the crankshaft over slowly by hand, to be sure it rotates freely.



WARNING: DO NOT ROTATE ENGINE WITH ELECTRIC STARTER WITH SPARK PLUGS REMOVED. ARCING AT THE SPARK PLUG ENDS MAY IGNITE THE GASOLINE VAPOR EXITING THE SPARK PLUG HOLE.

Engine Cranks Slowly –

- a. Additional load affecting performance (see note above).
- b. Discharged battery.
- c. Faulty electrical connection (battery circuit).
- d. Discharged battery (see alternators).
- e. Dirty or worn starter motor commutator, bearing, weak magnets, etc.
- f. Worn brushes or weak brush spring.
- g. Wrong oil viscosity for temperature expected.
- h. Battery leads too long or wire too small.
- i. Battery too small.

Engine Will Not Crank –

- a. Faulty safety interlocks.
- b. Discharged or defective battery.
- c. Faulty electrical connections.
- d. Faulty starter motor switch (open circuit).
- e. Open circuit in starter motor.
- f. Brushes sticking, etc.
- g. Faulty solenoid.

Starter Motor Spins, But Does Not Crank Engine –

- a. Sticking pinion gear due to dirt.
- b. Damaged pinion or ring gear.
- c. Battery faulty or damaged.
- d. Incorrect rotation due to reversed motor polarity – all motors rotate counterclockwise viewed from pinion gear.

Starter Motor Spins, Will Not Stop –

- a. Defective starter switch.

TEST EQUIPMENT

The following is a list of equipment recommended to test and repair starter motors.

Digital Multimeter

The Digital Multimeter is available from your Briggs & Stratton source of supply. Order as Tool #19390. The meter may be used to read volts, ohms, amperes and test diodes (rectifiers), Fig. 3.

The Digital Multimeter is equipped with two fuses to prevent damage to the meter in the event that the input limits are exceeded. If the meter displays a reading of 0.00 when testing DC output, check fuses in meter. Refer to FLUKE Operators Manual for procedure for checking fuses. Replacement fuse is available from your Briggs & Stratton source of supply. Order Part No. 19449.

DC Shunt

The Digital Multimeter will withstand DC input of 10-20 Amps for up to 30 seconds. When checking current draw of 12 volt starter motors, the DC Shunt, Tool #19359, is required, Fig. 4.

Tachometer

The tachometer, Tool #19200 is available from your Briggs & Stratton source of supply. The tachometer measures from 800 to 50,000 RPM, Fig. 5.

Test Bracket

A starter motor test bracket may be made as shown in Fig. 6.

IMPORTANT: DO NOT clamp motor housing in a vise or strike with a steel hammer. Starter motors contain two ceramic magnets which can be broken or cracked if the motor housing is hit, deformed or dented.

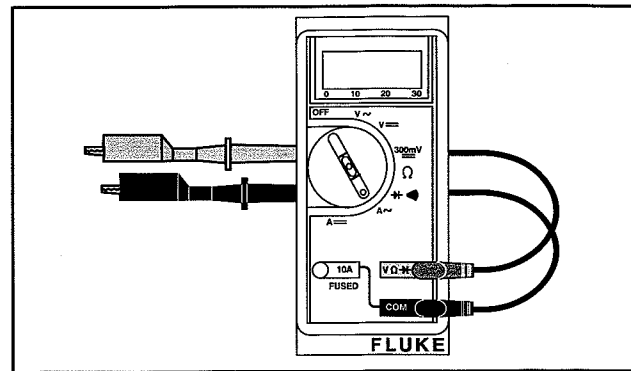

Fig. 3 – Digital Multimeter – Toll No. 19357 or 19390

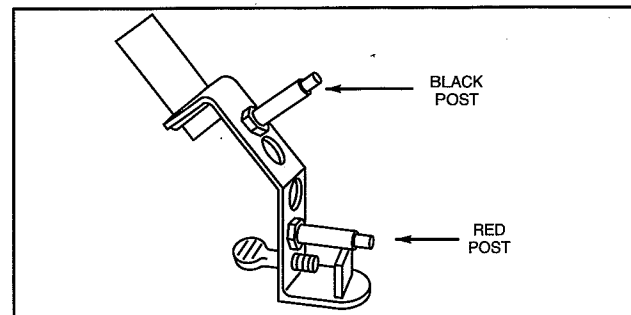

Fig. 4 – DC Shunt – Tool No. 19359

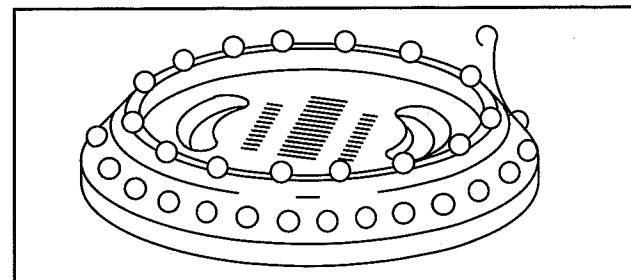

Fig. 5 – Tachometer – Tool No.19200

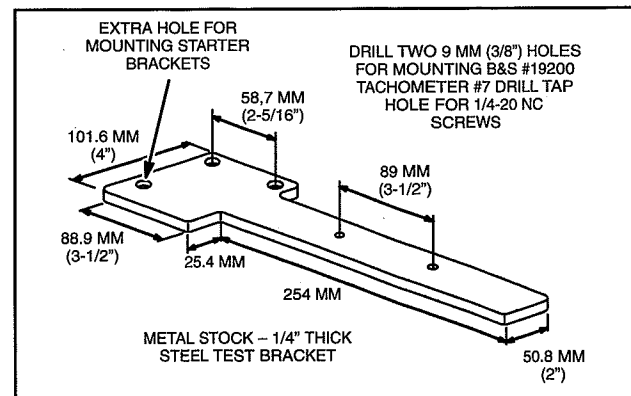

Fig. 6 – Test Bracket

TEST STARTER MOTOR

Remove Starter Motor

It is recommended that the starter motor be removed from the engine when testing starter motor performance. Remove starter shield. Remove two starter motor mounting screws using universal socket, Tool #19353. Assemble starter to test bracket and clamp test bracket in vise, Fig. 7.

Testing Starter Motor

A fully charged 12 volt battery is required.

1. The DC Shunt **MUST** be installed on the **negative** (-) battery terminal as shown in Fig. 7.
2. Insert RED test lead into $V \Omega \rightarrow$ receptacle in meter and connect to RED post terminal on shunt.
3. Insert BLACK test lead into **COM** receptacle in meter and connect to BLACK post terminal on shunt.
4. Rotate selector to **300mV** $\overline{=}$ position.
5. Activate the starter motor and note reading on meter and tachometer (RPM).
6. A starter motor in good condition will be within specifications listed.

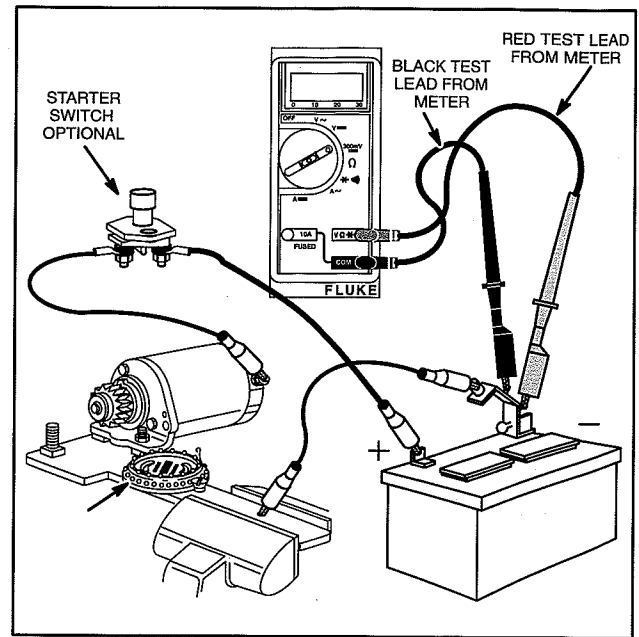

Fig. 7 – Testing 12 Volt Starter Motor Digital Multimeter & DC Shunt

STARTER MOTOR SPECIFICATIONS

| Pinion Type | Minimum Motor RPM | Maximum Amperes |
|-------------|-------------------|-----------------|
| Nylon | 6500 | 35 |
| Steel | 7000 | 24 |

If 12 volt starter motor does not perform satisfactorily, see Conditions Affecting Starter Motor Performance.

Conditions Affecting Starter Motor Performance

1. A binding or seizing condition in the starter motor bearings.
2. A shorted, open or grounded armature.
 - a. Shorted, armature (wire insulation worn and wires touching one another). Will be indicated by low or no RPM.
 - b. Open armature (wire broken) will be indicated by low or no RPM and excessive current draw.
 - c. Grounded armature (wire insulation worn and wire touching armature lamination or shaft). Will be indicated by excessive current draw or no RPM.
3. A defective starter motor switch.
4. Weakened magnets.
5. Starter drive dirty or binding.

STARTER DRIVE

Checking Starter Motor Drive

When the starter motor is activated, the pinion gear should engage the flywheel ring gear and crank the engine. If the starter motor drive does not react properly, inspect the helix and pinion gear for freedom of operation.

The pinion gear should be inspected for damaged teeth. Pinion gear must move freely on helix. The parts may be washed in a solvent such as Stanisol® or Varsol®.

Nylon pinion type starter drives have two styles of retainer mechanisms as shown in Fig. 8 and Fig. 9. Steel pinion style starter drive is shown in Fig. 10.

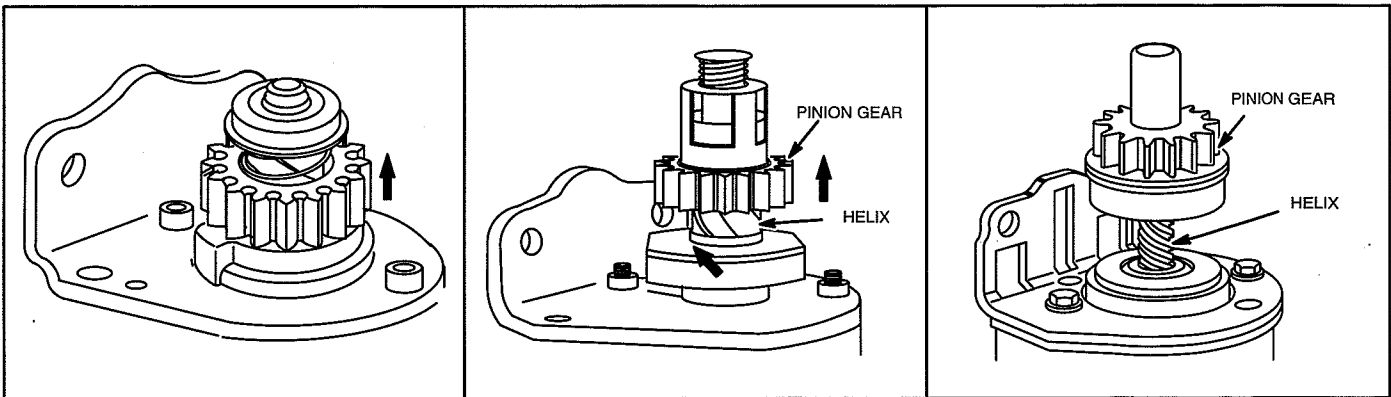

Fig. 8 – C-Ring Style – Nylon Pinion

Fig. 9 – Roll Pin Style – Nylon Pinion

Fig. 10 – Steel Pinion Style

6B

Disassemble Starter Drive – C-Ring Style



WARNING: TO PREVENT EYE INJURY ALWAYS WEAR EYE PROTECTION WHEN REMOVING C-RING.

1. Place counterbore side of Tool #19436 over retainer and align drive pins with open end of C-Ring, Fig. 11.

Important: If retainer has a notch as shown, **DO NOT** align drive pins with notch. If necessary, rotate notch away from open end of C-Ring.

2. While applying pressure, turn knurled knob clockwise until C-Ring pops off. Discard C-Ring.
3. Remove retainer, return spring, spring washer, pinion gear, and starter clutch.

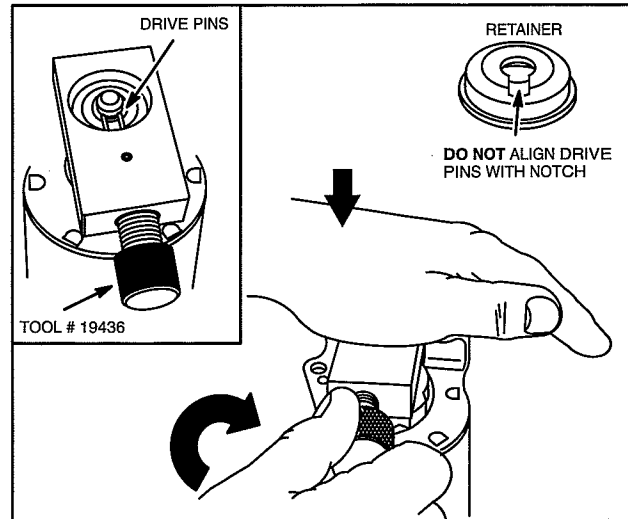

Fig. 11 – Removing C-Ring

Assemble Starter Drive – C-Ring Style

1. Assemble clutch drive to starter shaft and rotate clutch until it drops into place, Fig. 12.
2. Install pinion gear with beveled side of teeth up. Then install return spring making sure spring is in recess of starter gear.
3. Install spring washer with concave side up. Install retainer.

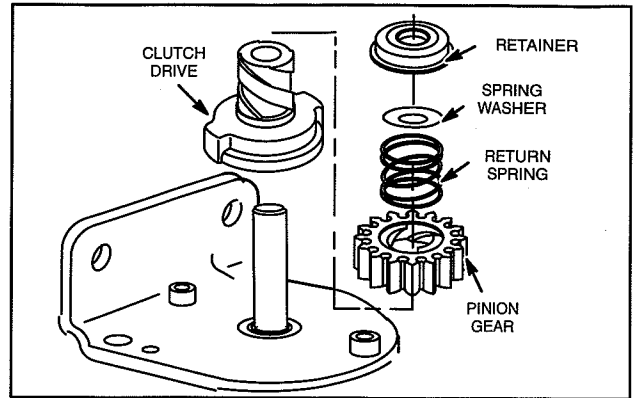

Fig. 12 – Removing Starter Drive

4. Place C-Ring over chamfered end of shaft. Align one of the slots of Tool #19435 with open end of C-Ring.
5. Press or drive C-Ring on until it snaps into groove in shaft, Fig. 13.

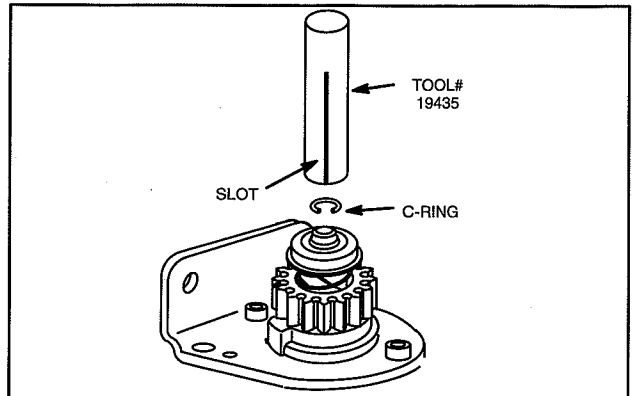

Fig. 13 – Installing C-Ring

Disassemble Starter Motor Drive – Roll Pin Style

1. Place starter drive retainer on support block, Fig. 14.
2. Drive out roll pin with a 4 mm (5/32") pin punch.
 - a. Discard roll pin
3. Remove retainer, washer, pinion gear, and starter clutch.

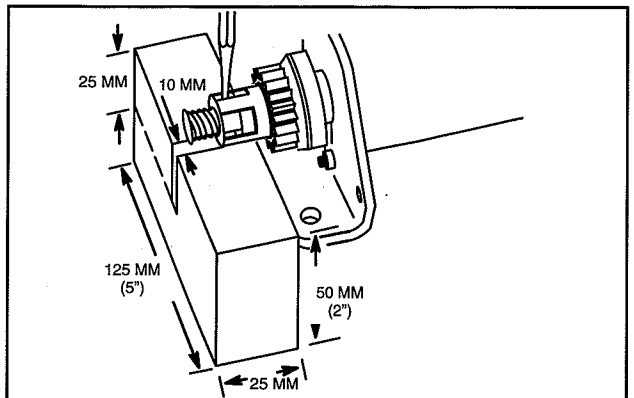

Fig. 14 – Disassembling Starter Drive

Assemble Starter Motor Drive – Roll Pin Style

1. Assemble clutch drive to starter shaft and rotate clutch until it drops into place, Fig. 15.
 2. Install pinion gear with beveled side of teeth up.
 3. Install washer and retainer.
 4. Install NEW retainer.
- Note:** Slot in roll pin should face up.

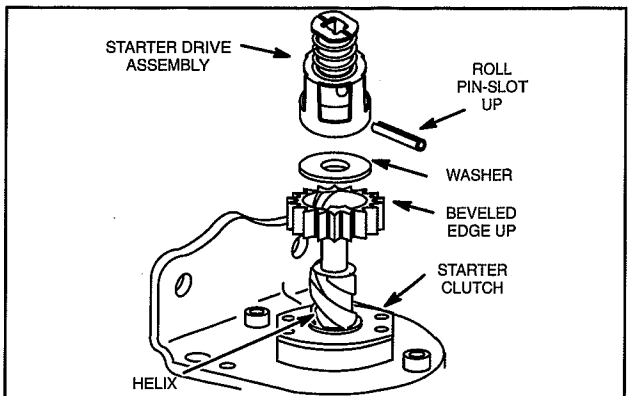

Fig. 15 – Assembling Starter Drive

Disassemble Starter Motor Drive – Steel Pinion

1. Grasp end of rubber dust cover and pull to remove.
2. Push down on upper spring retainer to expose retaining ring on shaft.
3. Use a small screw driver and pry off retaining ring.
 - a. Discard retaining ring.
4. Remove upper spring retainer, spring, lower spring retainer, pinion gear and clutch, Fig. 16.

Inspect Starter Drive – Steel Pinion

Check pinion gear for damaged worn or teeth. Rubber bottom of pinion is part of clutch. Check for wear or damage. Check clutch for wear.

If clutch rubber inside of pinion gear is worn or damaged, pinion gear will slip when starter is engaged.

Assemble Starter Drive – Steel Pinion

1. Lubricate helix with a light coat of grease.
2. Assemble clutch and pinion gear to shaft.
3. Assemble lower spring retainer with OPEN END UP.
4. Install spring.
5. Install upper spring retainer with OPEN END UP.
6. Compress spring and install NEW retaining ring on shaft.

7. Compress retaining ring with pliers to ensure that it is seated properly in groove in shaft.
8. Pull up on upper spring retainer until retaining ring snaps into groove in upper upper spring retainer.
9. Push dust cover down until it it snaps into groove in lower spring retainer.

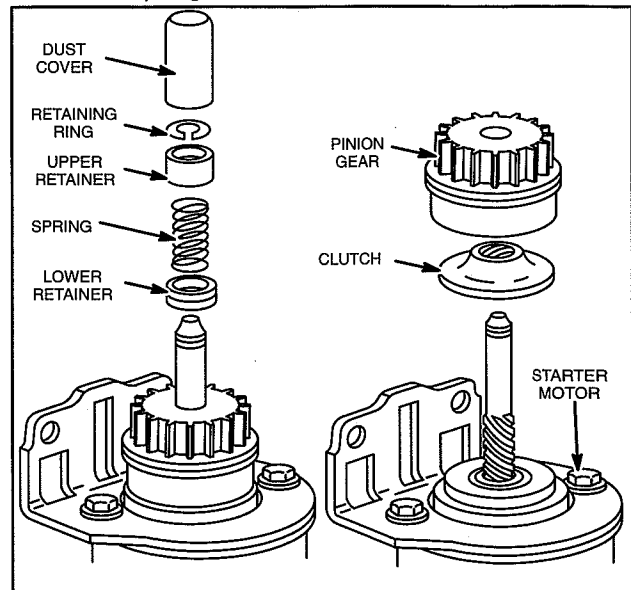

Fig. 16 – Steel Pinion Starter Drive

6B

DISASSEMBLE STARTER MOTOR

IMPORTANT: DO NOT clamp motor housing in a vise or strike with steel hammer. Starter motors contain two ceramic magnets which can be broken or cracked if the motor housing is hit, deformed, dented or dropped.

The disassembly and inspection procedure of the two style starter motors is similar. Where a procedure or specification is different, those differences will be shown.

1. See Fig. 17 or Fig. 18 for exploded view of two style starter motors. To aid in reassembly, scribe a mark on drive end cap and starter housing for alignment purposes. Remove thru bolts.

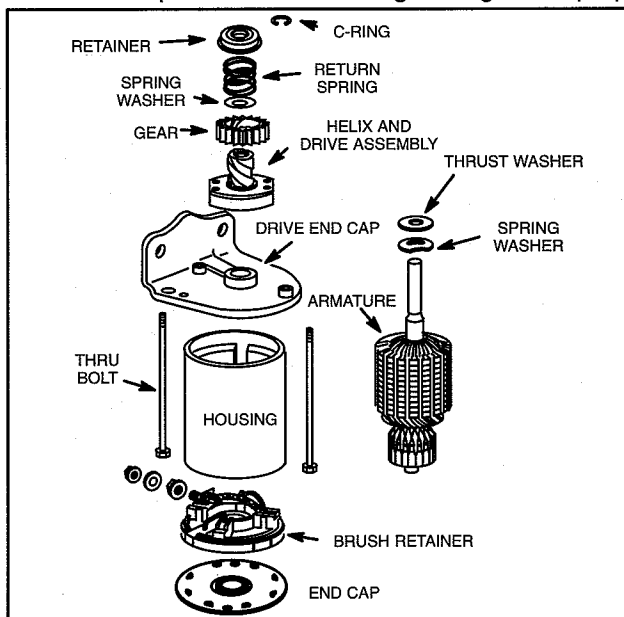

Fig. 17 – Starter Motor With Radial Compression Brush Spring (Typical)

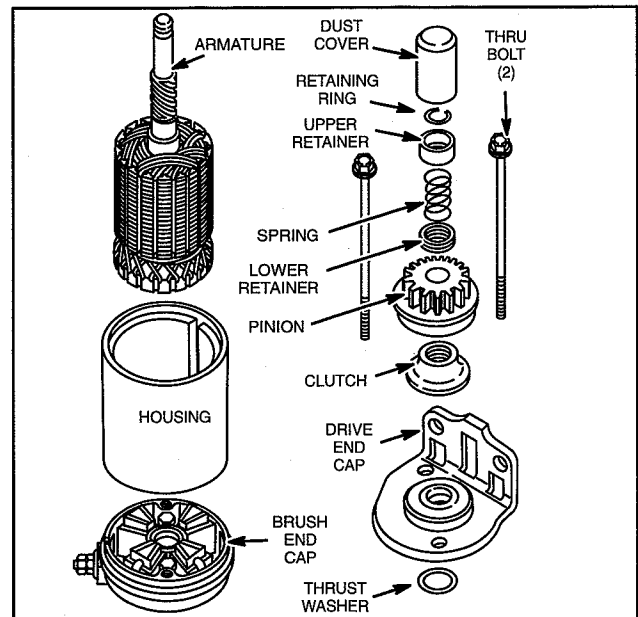

Fig. 18 – Starter Motor With Axial Compression Brush Spring (Typical)

2. Hold the armature and commutator end cap against a work surface while sliding housing off the armature, Fig. 19.

Note: This allows the brush retainer to remain assembled to commutator for inspection of brush to commutator contact.

3. Remove end cap and brush retainer with brushes. Replace end cap if bushing is worn or damaged.

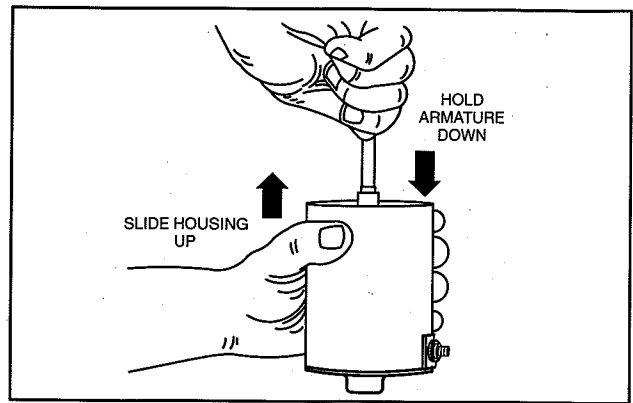

Fig. 19 – Removing Motor Housing

Inspect Armature Commutator

The style armature commutator shown in Fig. 20 A may be cleaned with fine sandpaper. DO NOT use emery cloth. Commutator may be machined to no less than 31.24 mm (1.230”).

Slots between commutator bars should be cleaned as shown in Fig. 20 A after cleaning or machining.

The armature should be checked for shorts with a growler.

Note: The style armature commutator shown in Fig. 20 B cannot be machined.

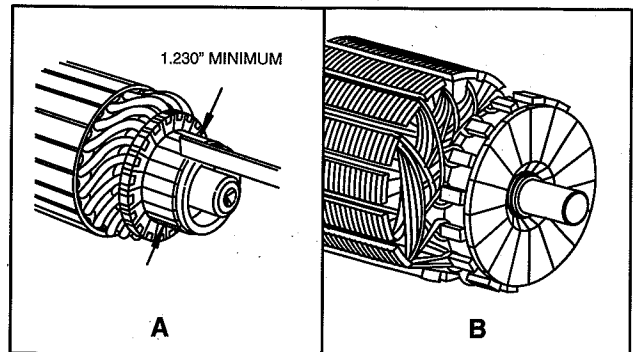

Fig. 20 – Inspect Commutator – Typical

Inspect Brushes

The brushes should be checked for proper seating, weak brush springs, dirt, oil or corrosion. Brush spring pressure should be strong enough to ensure good brush contact with armature. If brushes are worn as shown in Fig. 21, replace. Check to be sure brushes are not sticking in their holders.

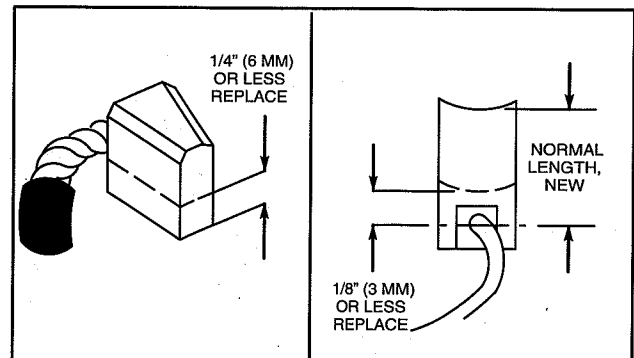

Fig. 21 – Cleaning Commutator – Typical

Replace Brushes

Three different style brush end caps are used. Refer to Fig. 22, Fig. 23 and Fig. 24 for correct location of brushes and brush leads. Note order of assembly for insulators, washers and screws or nuts.

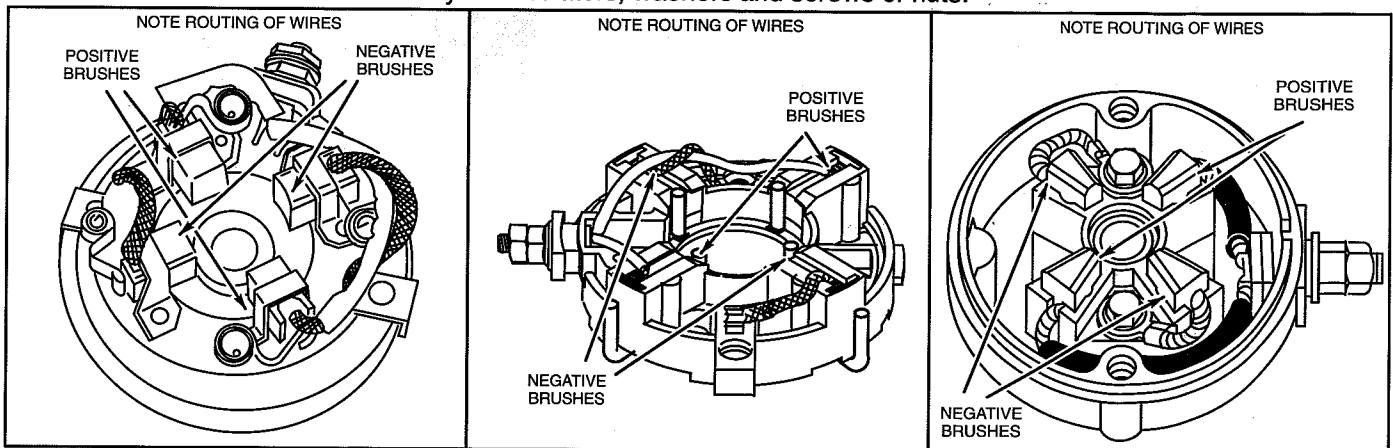

Fig. 22 – Radial Flat Coil Spring

Fig. 23 – Radial Compression Spring

Fig. 24 – Axial Compression Spring

ASSEMBLE STARTER

When all parts have been inspected, lightly lubricate bearings in both end caps with #20 oil.

Assemble End Cap – Radial Flat Coil Brush Spring

1. Assemble armature to brush end cap before installing brushes.
2. Install brush in holder.
3. Position coil spring over tab as shown in Fig. 25.
4. While holding spring on tab, use a screwdriver and bend spring clockwise and position over end of brush.
5. Push spring down firmly over tab.
6. Repeat for remaining brushes.

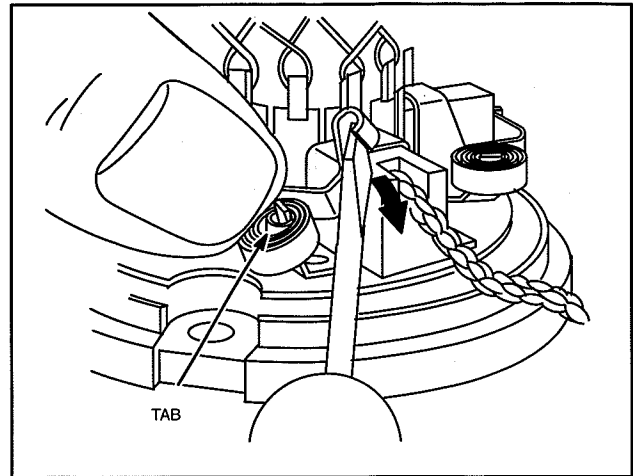

Fig. 25 – Installing Brushes

Assemble End Cap – Radial Compression Brush Spring

End caps with radial compression type springs require brush retainers to hold brushes clear of armature commutator.

Brush retainers can be made from Part No. 26634 control wire or similar material. See Fig. 26 for dimensions for making brush retainers.

1. Install brush spring and brush into holder.
2. Compress brush and spring and install retainer.
3. Repeat for remaining brushes.

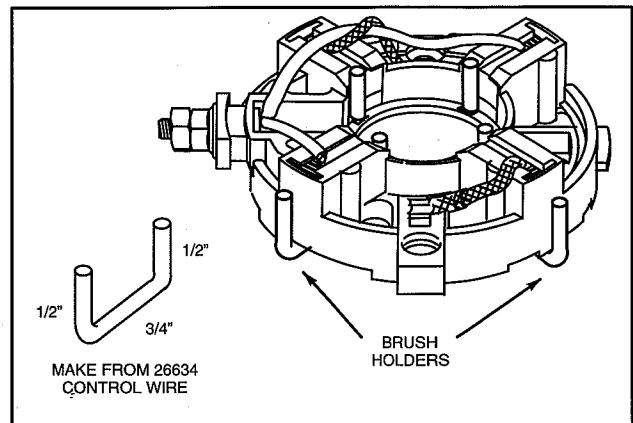

Fig. 26 – Installing Brushes

Assemble End Cap – Axial Compression Brush Spring

It is recommended that a brush retainer be used to hold brushes in place while assembling armature to end cap. See Fig. 27 for dimensions to make a sheet metal brush retaining tool.

1. Install brushes with beveled edge up in position shown, Fig. 28
2. Compress brushes and springs and assemble brush retainer to end cap, Fig. 29.

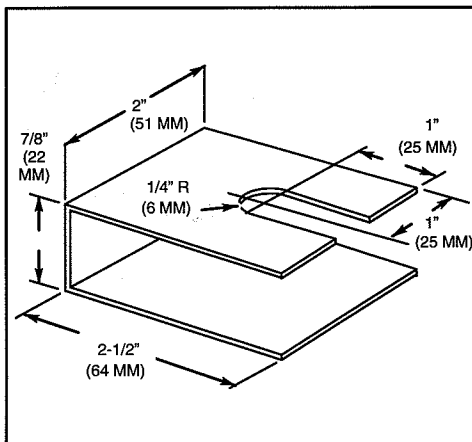

Fig. 27 – Brush Retainer

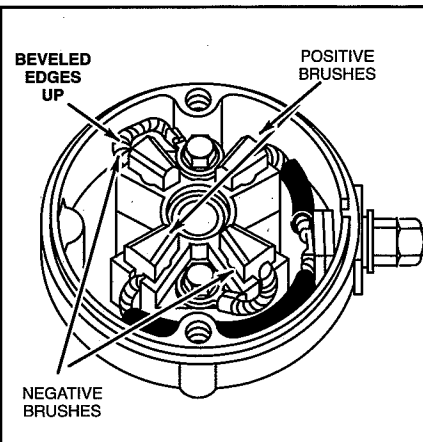

Fig. 28 – Brush Position

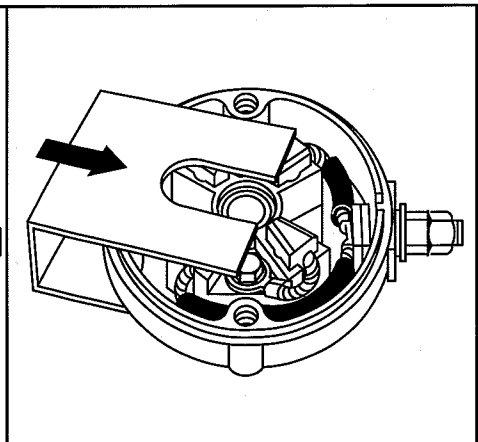

Fig. 29 – Compress Springs

Assemble Armature

When all parts have been inspected, lightly lubricate bearings in both end caps with #20 oil.

1. Install spacer on armature shaft (if equipped).
2. Assemble armature to brush end cap, Fig. 30.
3. Remove brush retainers.

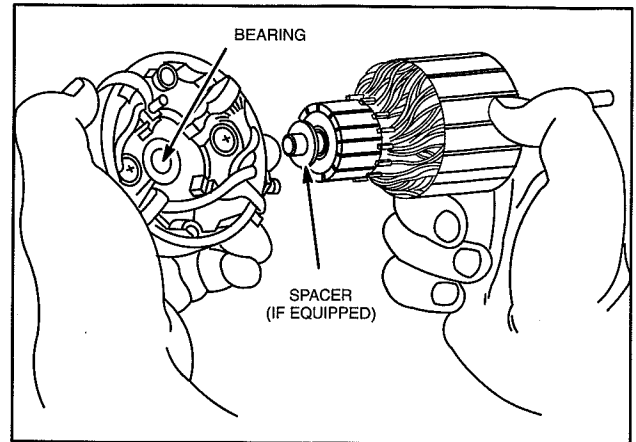

Fig. 30 – Assembling Armature to End Cap

Assemble Housing

The starter housing has a large notch which indexes over the insulated terminal, Fig. 31.

1. Push down on armature and brush end cap.
2. Slide starter housing over armature, aligning notch with insulated terminal.

Note: Use care to prevent damage to magnets in starter housing.

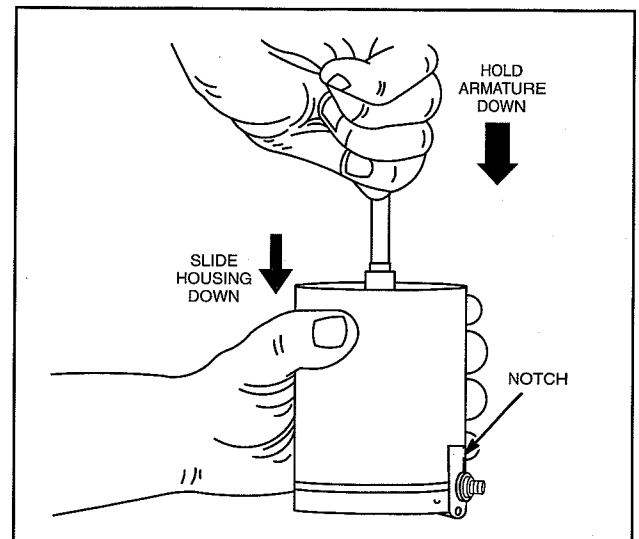

Fig. 31 – Assemble Housing

Install Drive End Cap

1. Assemble spacer washer and spring washer (if equipped) to armature shaft, Fig. 32.
2. Assemble drive end cap to armature shaft.
3. Align mark on end cap with mark on housing.
4. Install thru bolts.
 - a. Torque to 6.0 Nm (50 in. lbs.).

Turn armature to check for binding. Correct any binding if found.

Install starter drive.

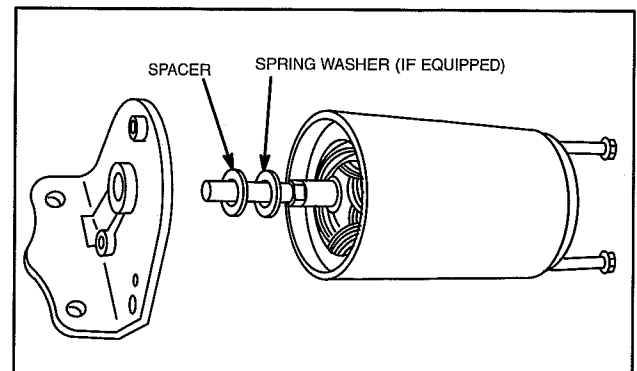

Fig. 32 – Installing Drive End Cap

Install Starter Motor

Install starter motor on engine using universal socket, Tool #19353. Torque screws to 16.0 Nm (140 in. lbs.). Install starter motor shield.

Wiring Diagram For Starter Panel & Key Switch For V-Twin Engines

| Terminal No. | Wire Color | Function |
|--------------|------------|---|
| 1 | Not Used | |
| 2 | White | To Carburetor Solenoid (when used) |
| 3 | Black | To Stop Switch Terminal On Engine |
| 4 | Yellow | To Solenoid (tab terminal) |
| 5 | Orange | To Battery (battery terminal on solenoid) |
| 6 | Red | To Regulator/Rectifier |

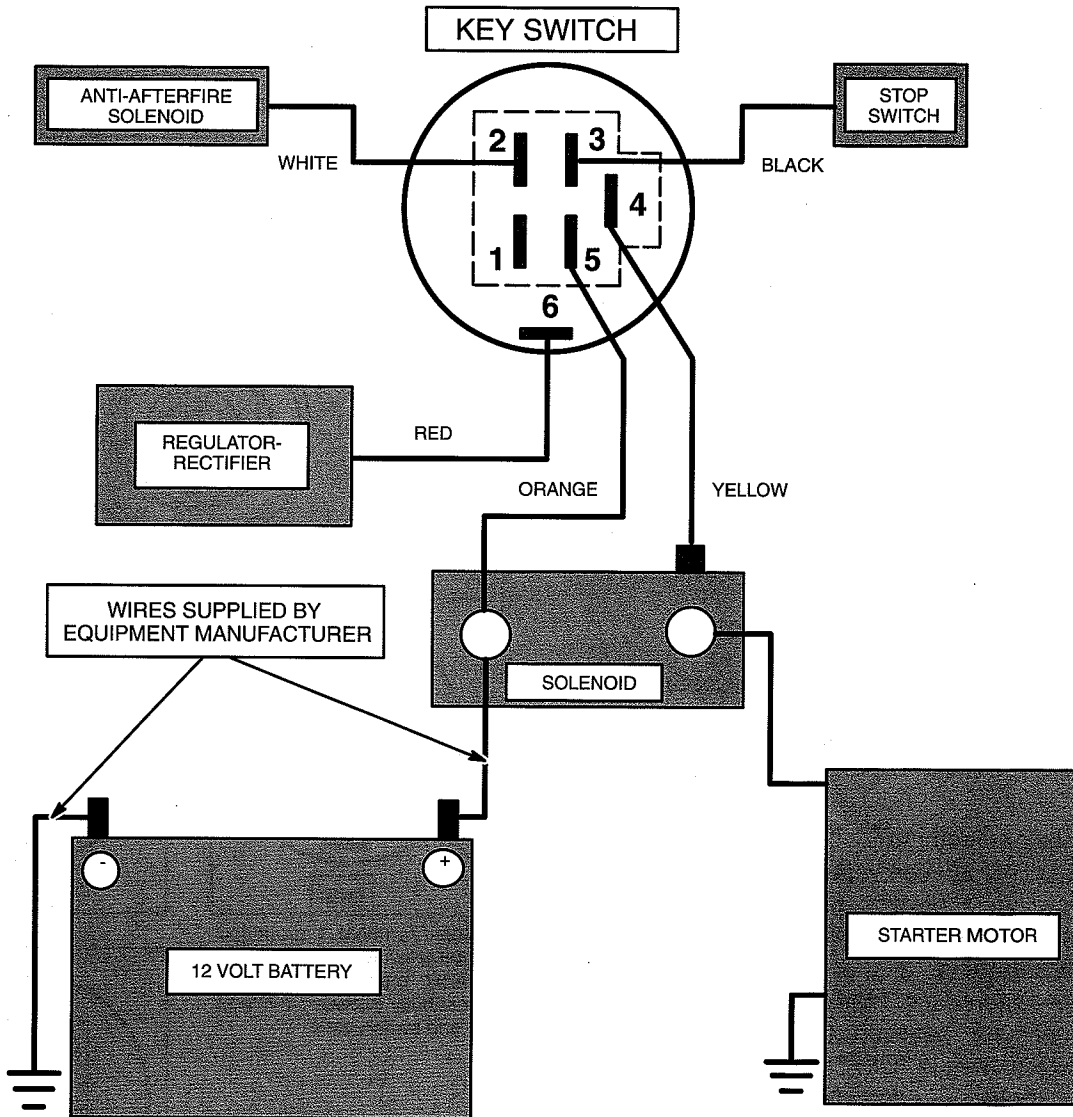

| Switch Position | Continuity |
|-----------------|------------|
| 1. OFF | 1+3+6 |
| 2. RUN | 2+5+6 |
| 3. START | 2+4+5 |

6B

Testing Starter Solenoid

The solenoid is a normally open, electrically activated switch. With the keyswitch in the "START" position, the switch closes, allowing battery current to flow to the starter motor and crank the engine.

1. The solenoid may be tested while mounted on engine.
2. A jumper test lead is required for this test.
3. Remove positive battery cable from battery. Then remove battery cable from stud terminal on solenoid.
4. Disconnect yellow wire from tab terminal on solenoid.
5. Keyswitch must be in "OFF" position.
6. Insert red test lead into $V \Omega \rightarrow$ receptacle in meter.
7. Insert black test lead into **COM** receptacle in meter.
8. Rotate meter selector to \rightarrow position.
9. Attach one meter test lead to each stud terminal on solenoid, Fig. 35.
10. Attach one end of jumper lead to positive terminal on battery.
11. Touch jumper wire to tab terminal on solenoid.
 - a. An audible "Click" should be heard as the solenoid switch "closes".
 - b. Meter should make a continuous tone (continuity).

Battery Information

The battery used to operate starter motors on Briggs & Stratton OHV-Twin engines is 12 volt, lead acid, wet cell type. This type is available as a wet charge or dry charge battery. The wet charged maintenance-free battery is filled with electrolyte and sealed at the time of manufacture. The level of electrolyte cannot be checked.

The dry charge battery is manufactured with fully charged plates. Electrolyte must be added at the time that the battery is placed in service. Before activating a dry charge battery, read and follow the manufacturer's recommended procedure.



WARNING: WEAR EYE PROTECTION WHEN SERVICING THE BATTERY. AVOID SKIN CONTACT. IF CONTACT DOES OCCUR, FLUSH WITH COLD WATER AND CONSULT A PHYSICIAN.



CAUTION: BEFORE SERVICING BATTERY, DISCONNECT NEGATIVE (-) BATTERY CABLE FIRST, THEN POSITIVE (+) CABLE SECOND.

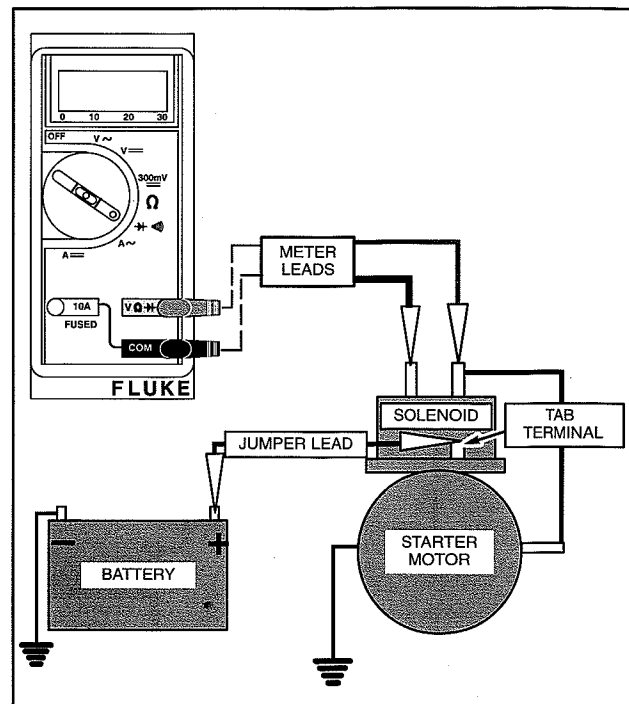

Fig. 35 – Testing Solenoid



WARNING: BATTERIES PRODUCE HYDROGEN, AN EXPLOSIVE GAS. DO NOT STORE OR CHARGE A BATTERY NEAR AN OPEN FLAME OR DEVICES WHICH UTILIZE A PILOT LIGHT OR CAN CREATE A SPARK.

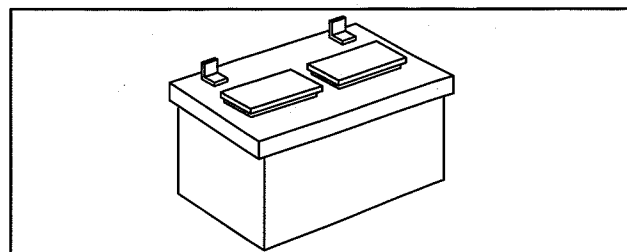

Fig. 36 – Typical Dry Charge Battery

Installation:

1. Before installing battery, connect all equipment to be operated.
2. Place battery in holder with flat base. Tighten holder down evenly until snug. DO NOT overtighten.
3. Connect positive terminal to positive post FIRST to prevent sparks from accidental grounding. Tighten connectors securely.

4. Connect negative terminal to negative battery terminal. Tighten connectors securely.

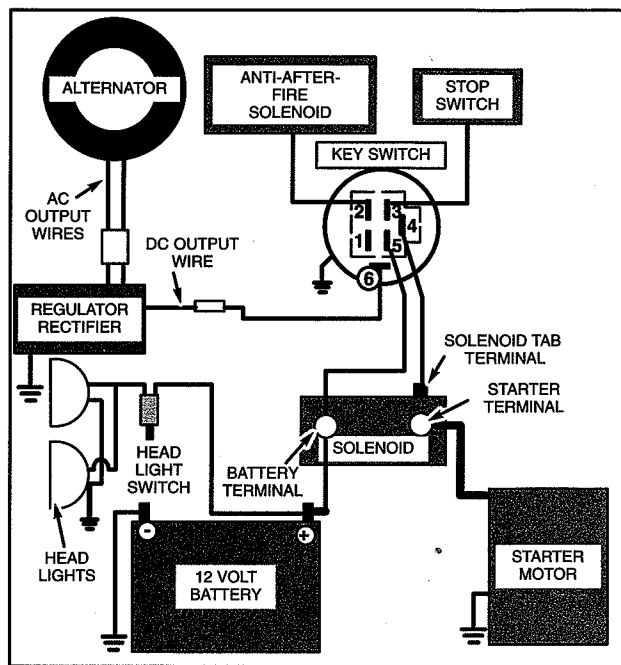

Fig. 37 - Typical 12 V Wiring Diagram

Checking Battery

1. Physical check - clean if necessary.
 - a. Corrosion
 - b. Dirt
 - c. Terminal and clamps (secure - good condition)
2. Bring battery to full charge.

WARNING: DO NOT EXCEED CHARGE RATE OF 1/10 AMPERE FOR EVERY AMPERE OF BATTERY RATING. CONSULT BATTERY MANUFACTURER FOR MAXIMUM CHARGE RECOMMENDATIONS.

- a. Use a taper charge (automatically reduces charge rate).
- b. Fill battery cells with distilled water or tap water after charging (for batteries that have been in service).

Note: If battery gets "Hot" to the touch or is spitting acid (gassing) excessively, unplug charger periodically.

3. With battery fully charged, check specific gravity readings of each cell with a Battery Hydrometer and record readings (Fig. 38). All readings should be above 1.250 (compensating for temperature). If specific gravity readings varied .50 or if all cells read less than 1.225, replace battery.

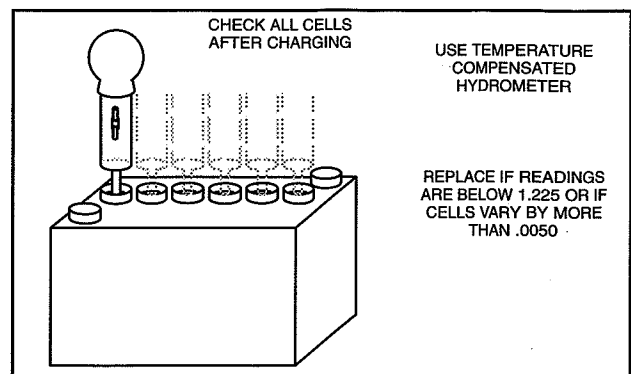

Fig. 38 - Checking 12 V Battery Cells (Lead Acid, Wet Cell, Dry Charge)

Testing Battery

Use Digital Multimeter, Tool #19357 or #19390
Set meter to read DC Volts.

Attach RED meter test clip to positive (+) battery terminal. Attach BLACK meter test lead to negative (-) battery terminal. With ignition switch "OFF," press starter button. If ignition switch and starter switch are the same switch, disconnect wires from spark plugs and ground ignition using two Ignition Testers, Tool #19368. Turn switch to "START." Meter should display 9 volts or more while cranking engine. If less than 9 volts, replace battery.

CAUTION: DO NOT CRANK STARTER MOTOR FOR MORE THAN 15 SECONDS WITHOUT ALLOWING STARTER MOTOR TO COOL AT LEAST 2 MINUTES.

Battery Recommendations

These battery size recommendations are based on minimum temperature expected and correct weight of oil being used. See Section 8.

- 30 Amp. Hr. -6° C (+20° F) or higher
- 40 Amp. Hr. -20° C (-5° F) or higher
- 50 Amp. Hr. -26° C (-15° F) or higher

Battery Cable Recommendations

These cable sizes are based on total length of cable from battery positive post to starter switch or solenoid, and to starter plus ground return to battery negative post.

- #6 AWG - 1.2 m (4 ft.) or less
- #5 AWG - 1.5 m (5 ft.) or less
- #4 AWG - 1.8 m (6 ft.) or less

Section 7

ALTERNATORS

| Section Contents | Page |
|---|------|
| ALTERNATOR IDENTIFICATION | 2 |
| FLYWHEEL IDENTIFICATION | 4 |
| TROUBLESHOOTING | 5 |
| TEST EQUIPMENT | |
| Digital Multimeter And DC Shunt | 5 |
| ALTERNATOR OUTPUT TESTING | 5 |
| AC ONLY ALTERNATOR | 6 |
| AC Output Test | 6 |
| DC ONLY ALTERNATOR | 6 |
| Alternator Output Test | 6 |
| Diode Test | 7 |
| DUAL CIRCUIT ALTERNATOR | 7 |
| Alternator Output Test | 7 |
| Diode Test | 8 |
| AC Output Test | 8 |
| TRI-CIRCUIT ALTERNATOR | 8 |
| Alternator Output Test | 9 |
| Diode Test | 9 |
| Charging Circuit (Red Wire) | 9 |
| Lighting Circuit (White Wire) | 9 |
| 5 & 9 AMP REGULATED ALTERNATOR | 10 |
| Alternator Output Test | 10 |
| Testing Regulator-Rectifier | 10 |
| 10 & 16 AMP REGULATED ALTERNATOR | 11 |
| Alternator Output Test | 11 |
| Test Regulator-Rectifier | 11 |
| Testing Regulator-Rectifier 10 Amp System | 11 |
| Testing Regulator-Rectifier 16 Amp System | 11 |
| Regulator-Rectifier With Charge Indicator | 12 |
| 20 AMP ALTERNATOR | 14 |
| Alternator Output Test | 14 |
| Testing Regulator-Rectifier | 15 |
| Test Lighting Circuit (-DC) | 15 |
| BATTERIES | 15 |
| Installation | 16 |
| Checking Battery | 16 |
| SPECIFICATION TABLES | |
| Table No. 1 – Alternator Identification | 2 |
| Table No. 2 – Flywheel Identification | 4 |

The alternator systems installed on Briggs & Stratton OHV-Twin Cylinder Engines can easily be identified by the color of the stator output wires and the connector.

Table No. 1 provides a means of identifying the various alternator systems.

Note: All output figures are rated at 3600 RPM.

TABLE NO. 1

| Fig. | Alternator Type | Stator Output Wire(s) Color | Connector Color | Alternator Output (at 3600 RPM) | Test Page |
|------|---------------------|-----------------------------|-----------------|--|-----------|
| 1 | AC Only | Black | White | 5 Amps AC (Lights) Unregulated | 6 |
| 2 | DC Only | Red | Red | 2-4 Amps + DC (Charging) Unregulated | 6 |
| 3 | Dual Circuit | Red Black | White | 2-4 Amps + DC (Charging) Unregulated 5 Amps AC (Lights) Unregulated | 7 |
| 4 | Tri-Circuit | Black | Green | 5 Amps + DC (Charging) 5 Amps - DC (Lights) | 9 |
| 5 | Regulated 5 Amp | Black | Green | * 1-5 Amps + DC (Charging) Regulated | 10 |
| 5 | Regulated 9 Amp | Black | Green | * 1-9 Amps + DC (Charging) Regulated | 10 |
| 6 | Regulated 10 Amp | 2-Black | Yellow | * 1-10 Amps + DC (Charging) Regulated | 11 |
| 6 | Regulated 16 Amp | 2-Black | Yellow | * 1-16 Amps + DC (Charging) Regulated | 11 |
| 7 | Regulated 20 Amp | 2-Yellow | White | * 1-20 Amps + DC (Charging) Regulated | 14 |

* Alternator output is determined by flywheel alternator magnet size.

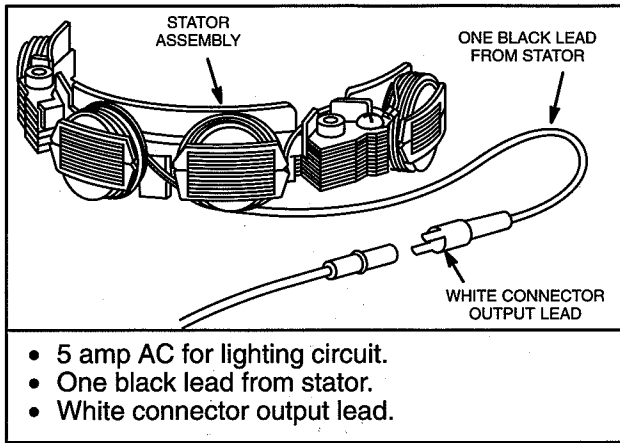

Fig. 1 – AC Only Stator

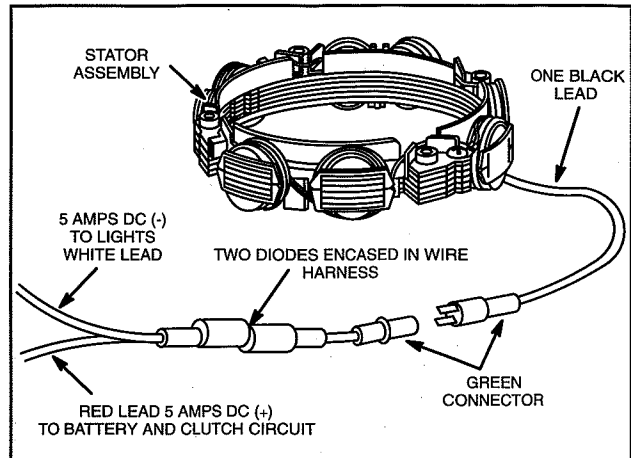

Fig. 4 – Tri-Circuit Stator

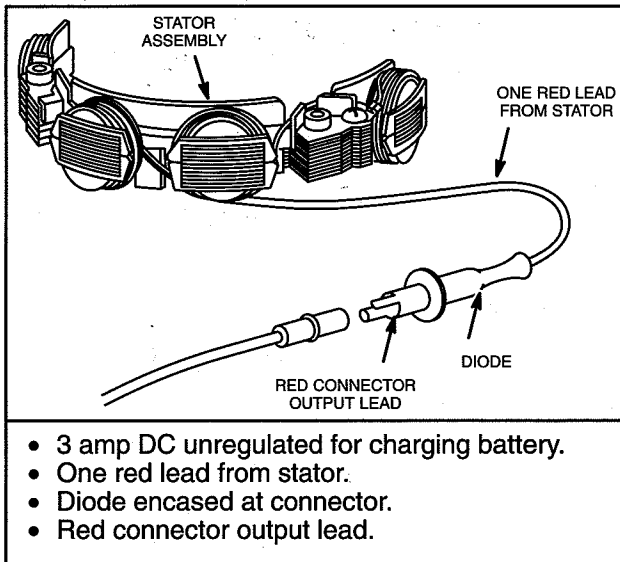

Fig. 2 – DC Only Stator

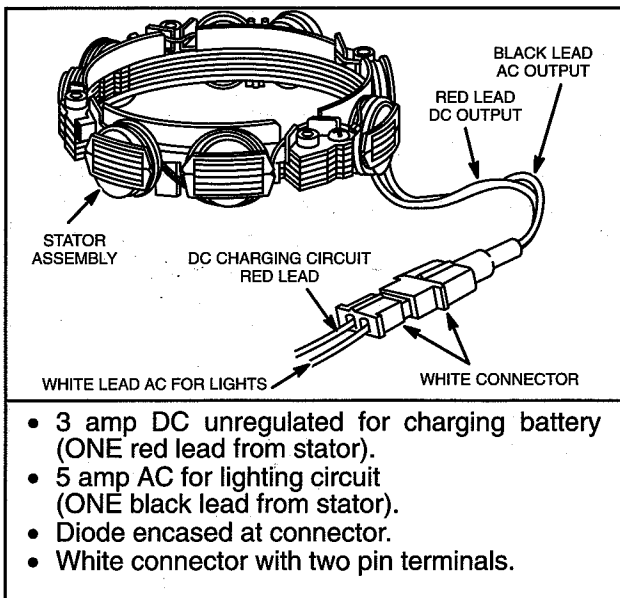

Fig. 3 – Dual Circuit Stator

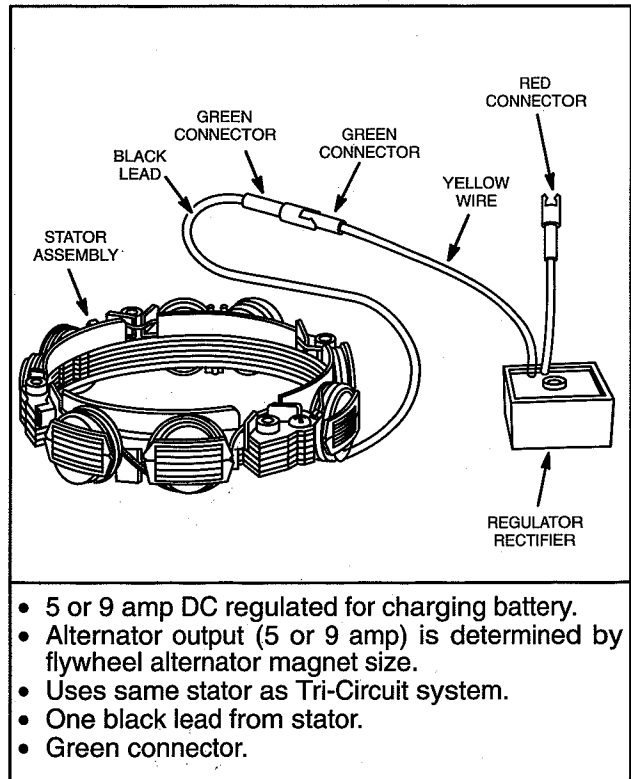

Fig. 5 – 5 or 9 Amp Regulated Stator

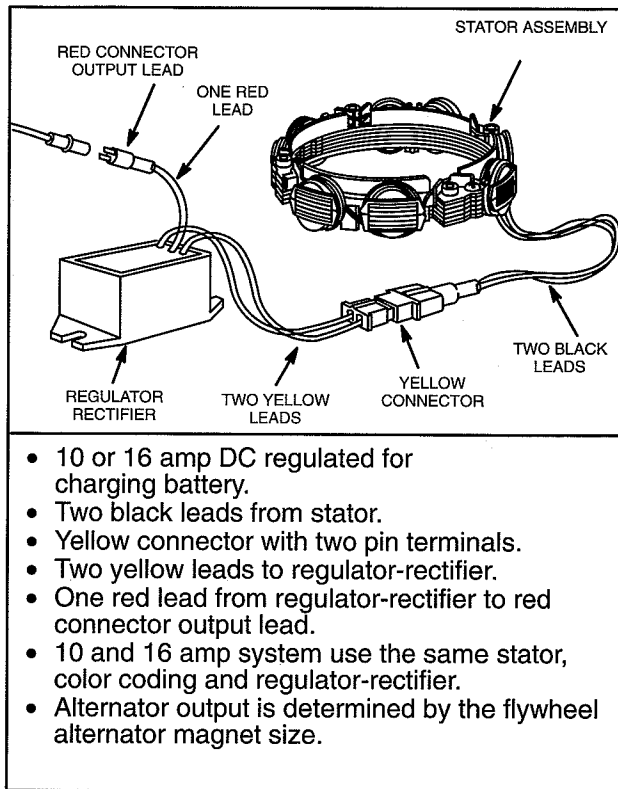

Fig. 6 – 10 or 16 Amp Regulated Stator

Flywheel Identification

OHV-Twin Cylinder Flywheels have a single ring of magnets which provide the magnetic field for the various alternator systems. There are three (3) sizes of alternator magnets. The size of the magnet determines the alternator output Fig. 8.

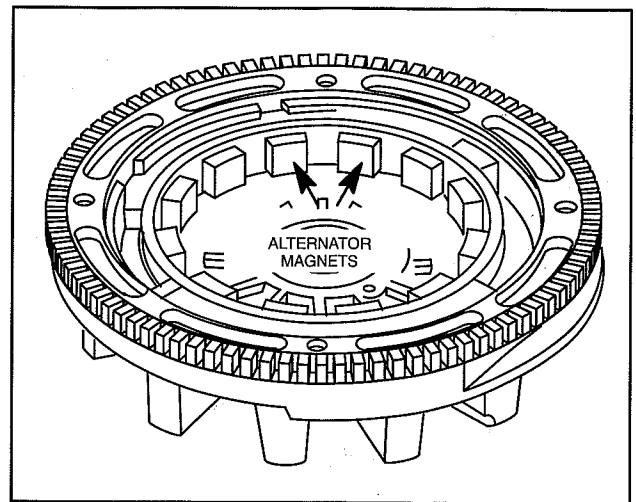

Fig. 8 – Alternator Magnets

Small Magnet 22 mm x 17 mm (7/8" x 21/32")

Large Magnet 22 mm x 23 mm (7/8" x 29/32")

20 Amp Only 27 mm x 23 mm (1-3/32" x 29/32")

Table 2 identifies the magnet size to be used with a specific alternator system.

TABLE NO. 2

| Alternator | Small Magnet | Large Magnet | 20 A Flywheel |
|------------------|--------------|--------------|---------------|
| AC Only | • | | |
| DC Only | • | | |
| Dual Circuit | • | | |
| Tri-Circuit | • | | |
| Regulated 5 AMP | • | | |
| Regulated 9 AMP | | • | |
| Regulated 10 AMP | • | | |
| Regulated 16 AMP | | • | |
| Regulated 20 AMP | | | • |

Note: Large magnet flywheels cannot be used with the AC only, DC only, Dual Circuit and Tri-Circuit alternator systems.

The 20 Amp magnet flywheel is used ONLY with 20 amp regulated system.

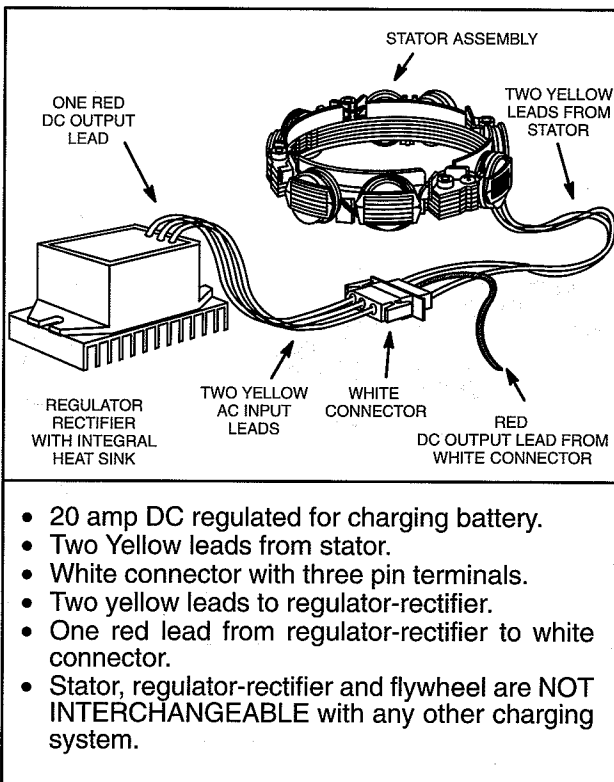

Fig. 7 – 20 Amp Regulated Stator

TROUBLESHOOTING

The following list is provided to aid you in diagnosing problems with alternator systems.

| COMPLAINT | POSSIBLE CAUSES |
|---|---|
| "Battery not charging" | <ul style="list-style-type: none"> • Engine RPM too low • Inline fuse "blown" (if equipped) • Defective battery • Loose, pinched, or corroded battery ground leads • Loose, pinched, or corroded battery charge leads • Open, shorted, or grounded wires between output connector and battery • Defective diode (open or shorted) • Defective or improperly grounded regulator-rectifier • Diode installed incorrectly (reversed) • Damaged battery (shorted battery cells) • Excessive current draw from accessories • Low magnetic flux or damaged alternator magnets |
| "Battery in state of overcharge" | <ul style="list-style-type: none"> • Severe battery vibration (missing or broken tie-down straps) • Battery rate of charge not matched to alternator output • Damaged battery (shorted battery cells) • Defective regulator • One OHM resistor shorted or grounded (Tri-Circuit system only) |
| "Headlamps not working" | <ul style="list-style-type: none"> • Inline fuse "blown" (if equipped) • Defective headlamps • Loose or corroded wires • Open, shorted or grounded wires between output connector and headlamps • Light switch defective • Defective diode Tri-Circuit system (open or shorted – white output lead side) • Low magnetic flux or damaged alternator magnets |
| "Electric clutch not working" (Tri-Circuit Alternator) | <ul style="list-style-type: none"> • Inline fuse "blown" (if equipped) • Loose or corroded wires • Open, shorted or grounded wires between output connector and electric clutch • Defective diode (open or shorted-red output lead side) • Note: Battery will also not charge • Defective electric clutch switch • Open, shorted or grounded clutch circuit • Low magnetic flux or damaged alternator magnets |

7

TEST EQUIPMENT

The following equipment is recommended to test and repair alternators.

Digital Multimeter

The Digital Multimeter is available from your Briggs & Stratton source of supply. Order as Tool #19390. The meter may be used to read volts, ohms or amperes, and test diodes, when leads are inserted in the appropriate receptacle, Fig. 9.

The Digital Multimeter will withstand DC input of 10-20 amps for up to 30 seconds. When checking DC output on 16 and 20 amp regulated system, use the DC shunt, Tool #19359, to avoid blowing fuse in meter, Fig. 10.

Note: The Digital Multimeter is equipped with two fuses to prevent damage to the meter in the event that the input limits are exceeded. If the meter displays a reading of 0.00 when testing DC output (**A** ==), check fuses in meter. Refer to FLUKE Operators Manual for procedure for checking fuses. Replacement Fuses are avail-

able from your Briggs & Stratton source of supply. Order Part No. 19449.

Testing Alternator Output

When checking alternators, make the tests in the following sequence.

1. Test alternator output.
2. Test diode(s) or regulator, rectifier (if equipped).

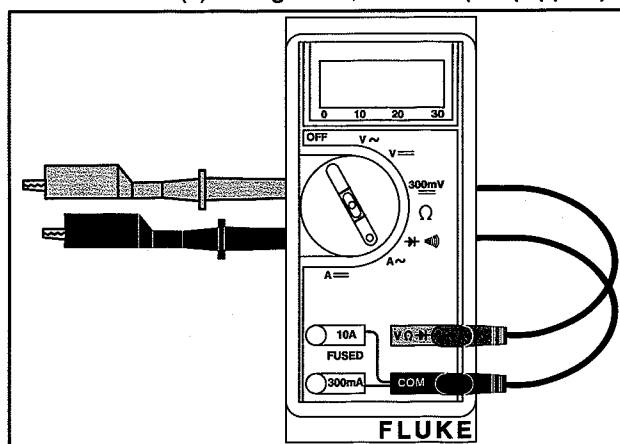

Fig. 9 – Digital Multimeter

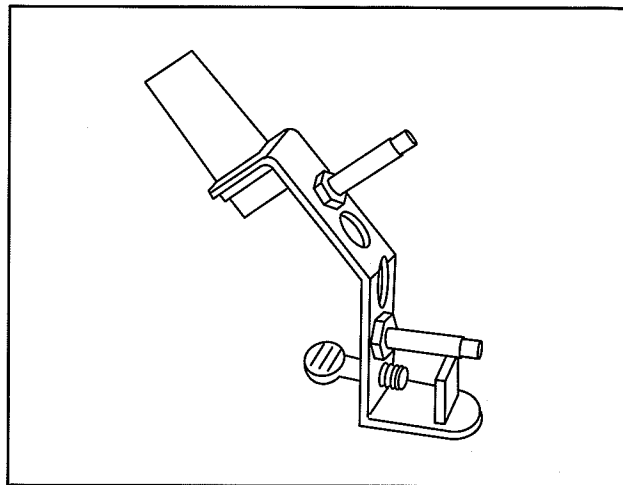

Fig. 10 – DC Shunt – Tool No. 19359

Note: Before testing the alternator's output (volts, amps), first use an accurate tachometer and temporarily adjust the engine speed to the RPM specified in the test instructions.



WARNING: UPON COMPLETION OF THE ALTERNATOR OUTPUT TEST, ALWAYS READJUST THE ENGINE RPM TO ITS CORRECT TOP NO LOAD GOVERNED SPEED! OTHERWISE ENGINE MAY EXCEED SAFE OPERATING SPEED WHICH COULD CAUSE PERSONAL INJURY. Correct speed is found in the Service Engine Sales Manual Microfiche, MS-6225 or the Service Sales Manual, MS-4052.

AC ONLY ALTERNATOR

The AC alternator provides current for headlights only. Current for the lights is available as long as the engine is running. The output depends upon engine speed. 12 volt lights with a total rating of 60 to 100 watts may be used. With lights rated at 70 watts, the voltage rises from 8 volts at 2400 RPM to 12 volts at 3600 RPM, so the brightness of the light changes with the engine speed.

AC Output Test

1. Insert RED test lead into $V \Omega \rightarrow$ receptacle in meter.
2. Insert BLACK test lead into **COM** receptacle in meter.
3. Rotate selector to $V \sim$ (AC volts) position.
4. Attach RED test lead clip to AC output terminal, Fig. 11.

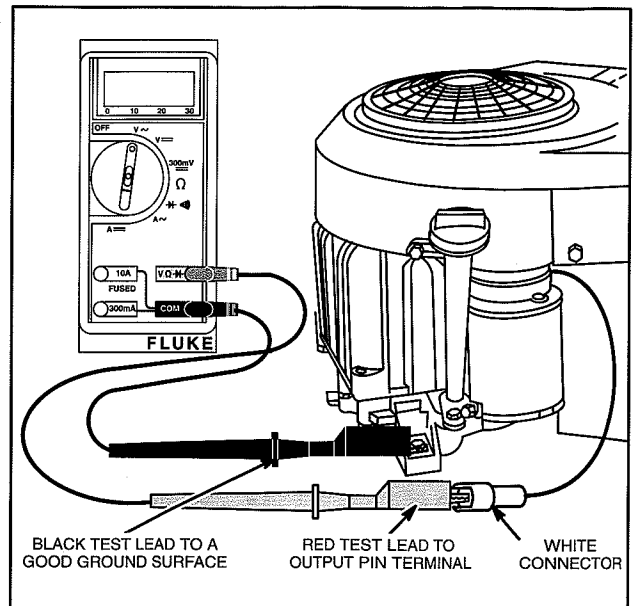

Fig. 11 – Testing AC Output

5. Attach BLACK test lead clip to engine ground.
6. With engine running at 3600 RPM, AC output should be no less than 14 volts.
7. If no or low output is found, replace the stator.

DC ONLY ALTERNATOR

The DC alternator provides DC current for charging a 12 volt battery. The current from the alternator is unregulated and is rated at 3 amps. The output rises from 2 amps at 2400 RPM, to 3 amps at 3600 RPM.

Recommended battery sizes range from 30 ampere hour for warm temperature service to 50 ampere hour in coldest service.

WHEN CHECKING ALTERNATOR COMPONENTS, MAKE THE TEST IN THE FOLLOWING SEQUENCE:

Alternator Output Test

1. Insert RED test lead into 10 A receptacle in meter.
2. Insert BLACK test lead into **COM** receptacle in meter.
3. Rotate selector to $A \equiv$ (DC amps) position.
4. Attach RED test lead clip to DC output terminal, Fig. 12.
5. Attach BLACK test lead clip to positive (+) battery terminal.
6. With engine running at 3600 RPM, output should be between 2-4 amps DC.
 - a. Output will vary with battery voltage. If battery voltage is at its maximum, output will be approximately 2 amps.
7. If no or low output is found, test diode.

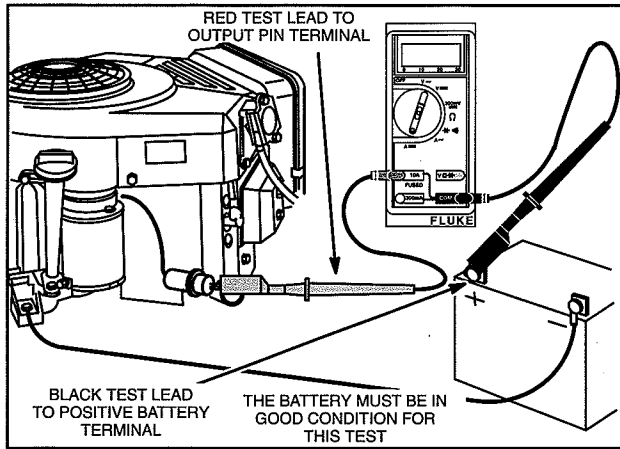

Fig. 12 – Testing DC Output

Diode Test

In the Diode Test position, the meter will display the forward voltage drop across the diode(s). If the voltage drop is less than 0.7 volts, the meter will “Beep” once as well as display the voltage drop. A continuous tone indicates continuity (shorted diode). An incomplete circuit (open diode) will be displayed as “OL.”

1. Insert RED test lead into $V \Omega \rightarrow$ receptacle in meter.
2. Insert BLACK test lead into **COM** receptacle in meter.
3. Rotate selector to \rightarrow (Diode Test) position.
4. Attach RED test lead clip to point “A” and BLACK test lead clip to point “B,” Fig. 13. (It may be necessary to pierce wire with a pin as shown.)
 - a. If meter “Beeps” once, diode is OK.
 - b. If meter makes a continuous tone, diode is defective (shorted). Replace diode.
 - c. If meter displays “OL,” proceed to step 5.
5. Reverse test leads.
 - a. If meter “Beeps” once, diode is installed backwards. Replace diode.
 - b. If meter still displays “OL,” diode is defective (open). Replace diode.
6. If diode tests OK, check stator for bare wires or other obvious defects. If grounded leads are not visible, replace the stator.

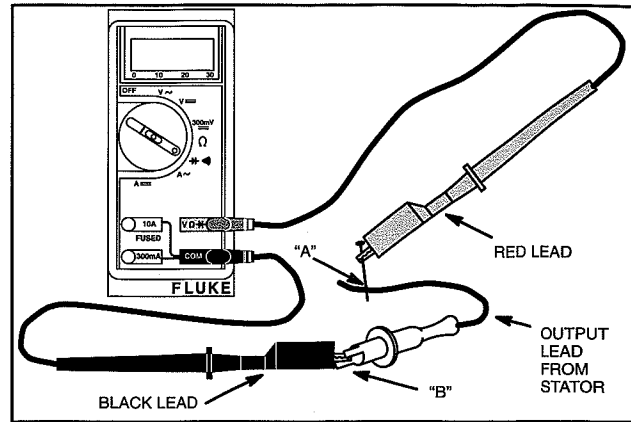

Fig. 13 – Testing Diode

Note: Service replacement diode harnesses are available. Use Resin Core solder when installing new harness. Use shrink tubing or tape all connections. DO NOT USE CRIMP CONNECTORS.

DUAL CIRCUIT ALTERNATOR

Dual circuit alternators use a single polarized plug with two pins. One pin is for charging the battery and the second is for the AC light circuit.

The dual circuit alternator provides DC current for battery charging and an independent AC circuit for headlights. The battery is not used for lights, so lights are available even if battery is disconnected or removed.

Current for lights is available as long as the engine is running. The output depends upon engine speed, so brightness of the lights changes with engine speed. 12 volt lights with a total rating of 60 to 100 watts may be used. With lights rated at 70 watts, the voltage rises from 8 volts at 2400 RPM to 12 volts at 3600 RPM.

The current from the DC side of the alternator is unregulated and is rated at 3 amps. The output rises from 2 amps at 2400 RPM to 3 amps at 3600 RPM.

Alternator Output Test

1. Insert RED test lead into 10 A receptacle in meter.
2. Insert BLACK test lead into **COM** receptacle in meter.
3. Rotate selector to $A \equiv$ (DC amps) position.
4. Attach RED test lead clip to DC output pin in connector, Fig. 14.

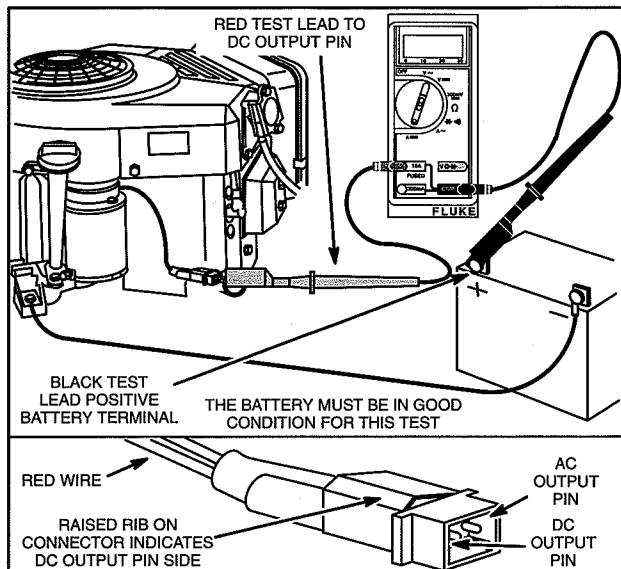

Fig. 14 – Testing DC Output

1. Attach BLACK test lead clip to positive (+) battery terminal.
2. With engine running at 3600 RPM output should be between 2-4 amps DC.
 - a. Output will vary with battery voltage. If battery voltage is at its maximum, output will be approximately 2 amps.
3. If no output or low output is found, test diode.

Diode Test

In the Diode Test position, the meter will display the forward voltage drop across the diode(s). If the voltage drop is less than 0.7 volts, the meter will “Beep” once as well as display the voltage drop. A continuous tone indicates continuity (shorted diode) An incomplete circuit (open diode) will be displayed as “OL.”

1. Insert RED test lead into $V \Omega \rightarrow$ receptacle in meter.
2. Insert BLACK test lead into **COM** receptacle in meter.
3. Rotate selector to \rightarrow (Diode Test) position.
4. Attach RED test lead clip to point “A” and BLACK test lead clip to point “B,” Fig. 15. (It may be necessary to pierce wire with a pin as shown.)
 - a. If meter “Beeps” once, diode is OK.
 - b. If meter makes a continuous tone, diode is defective (shorted). Replace diode.
 - c. If meter displays “OL,” proceed to step 5.
5. Reverse test leads.
 - a. If meter “Beeps” once, diode is installed backwards. Replace diode.
 - b. If meter still displays “OL,” diode is defective (open). Replace diode.
6. If diode tests OK, check stator for bare wires or other obvious defects. If grounded leads are not visible, replace the stator.

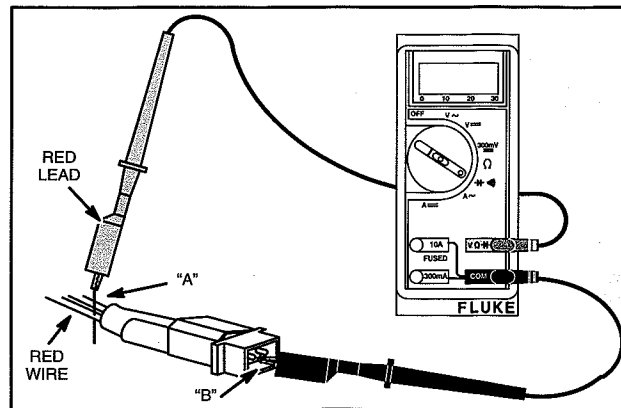

Fig. 15 – Testing Diode

Note: Service replacement diode harnesses are available. Use Resin Core solder when installing new harness. Use shrink tubing or tape all connections. **DO NOT USE CRIMP CONNECTORS.**

AC Output Test

1. Insert RED test lead into $V \Omega \rightarrow$ receptacle in meter.
2. Insert BLACK test lead into **COM** receptacle in meter.
3. Rotate selector to $V \sim$ (AC volts) position.
4. Attach RED test lead clip to AC output terminal, Fig. 16.

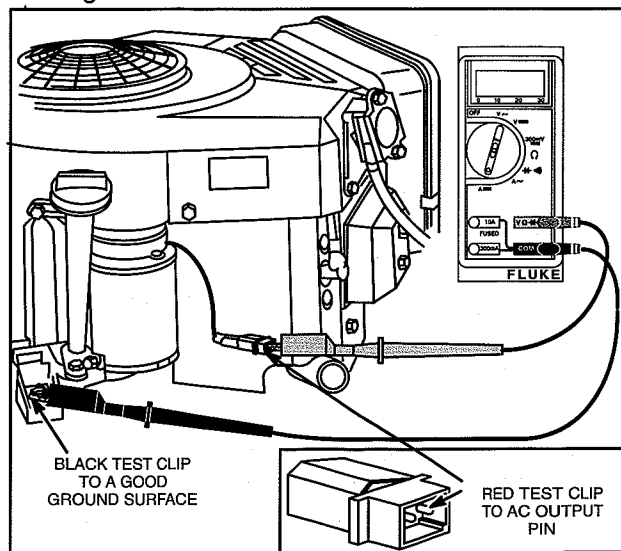

Fig. 16 – Testing AC Output

5. Attach BLACK test lead clip to engine ground.
6. With engine running at 3600 RPM output should be no less than 14 volts AC.
7. If no output or low output is found, replace stator.

TRI-CIRCUIT ALTERNATOR

The tri-circuit alternator provides alternating current through a single output lead and connector to a wiring harness containing two diodes.

One diode rectifies the AC current to 5 amps negative (-) DC for lights. The second diode rectifies the AC

current to 5 amps positive (+) DC for battery charging and external loads, such as an electric clutch.

Note: Some equipment manufacturers supply the diodes as an integral part of the equipment wiring harness.

Some equipment manufacturers use a 1 OHM 20 WATT resistor placed in series with (+) DC charging lead, limiting the charging current to approximately 3 amps when the clutch is not engaged. When the clutch is engaged the resistor is bypassed allowing full output to the battery and clutch.

Note: The 1 OHM 20 WATT resistor is supplied by the equipment manufacturer.

The battery is not used for the lights, so lights are available even if the battery is disconnected or removed. Current for the lights is available as long as the engine is running. The output depends upon engine RPM, so the brightness of the lights changes with engine speed.

Alternator Output Test

1. Insert RED test lead into $V \Omega \rightarrow +$ receptacle in meter.
2. Insert BLACK test lead into **COM** receptacle in meter.
3. Rotate selector to $V \sim$ (AC volts) position.
4. Attach RED test lead clip to output terminal, Fig. 17.

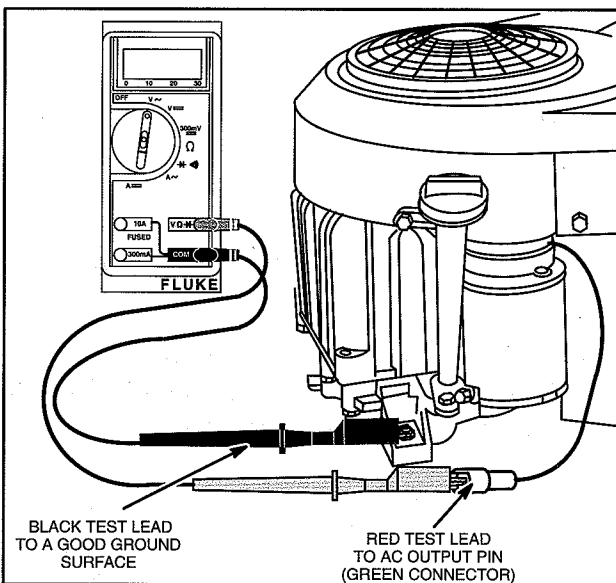

Fig. 17 – Testing Alternator Output

5. Attach BLACK test lead clip to engine ground.
6. With engine running at 3600 RPM, output should be no less than 28 volts AC.
7. If no output or low output is found, replace stator.
8. If alternator output is good, test diodes located in wiring harness.

Diode Test

Note: One diode is for the charging circuit and the other diode is for the lighting circuit.

In the Diode Test position, the meter will display the forward voltage drop across the diode(s). If the voltage drop is less than 0.7 volts, the meter will “Beep” once as well as display the voltage drop. A continuous tone indicates continuity (shorted diode) An incomplete circuit (open diode) will be displayed as “OL.”

Charging Circuit (Red Wire)

1. Insert RED test lead into $V \Omega \rightarrow +$ receptacle in meter.
2. Insert BLACK test lead into **COM** receptacle in meter.
3. Rotate selector to $\rightarrow +$ (Diode Test) position.
4. Attach BLACK test lead clip to point “A,” (red wire) Fig. 18. (It may be necessary to pierce wire with a pin as shown.)
5. Insert RED test lead probe into harness connector.
 - a. If meter “Beeps” once, diode is OK.
 - b. If meter makes a continuous tone, diode is defective (shorted). Replace harness.
 - c. If meter displays “OL,” proceed to step 6.
6. Reverse test leads.
 - a. If meter “Beeps” once, diode is installed backwards. Replace harness.
 - b. If meter still displays “OL,” diode is defective (open). Replace harness.

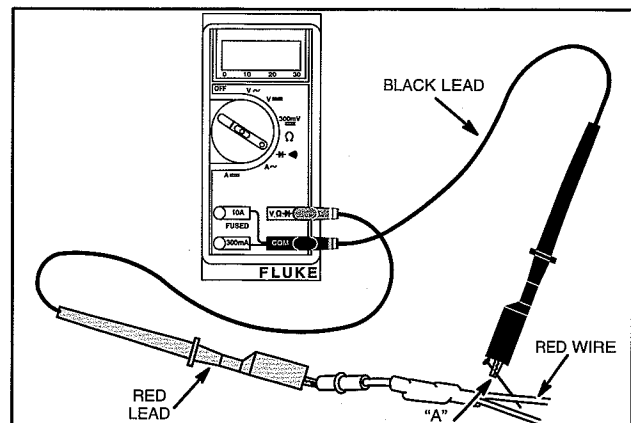

Fig. 18 – Diode Testing – Charging Circuit

Lighting Circuit (White Wire)

1. Insert RED test lead into $V \Omega \rightarrow +$ receptacle in meter.
2. Insert BLACK test lead into **COM** receptacle in meter.
3. Rotate selector to $\rightarrow +$ (Diode Test) position.
4. Attach RED test lead clip to point “A,” (white wire) Fig. 19. (It may be necessary to pierce wire with a pin as shown.)

5. Insert BLACK test lead probe into harness connector.
 - a. If meter "Beeps" once, diode is OK.
 - b. If meter makes a continuous tone, diode is defective (shorted). Replace harness.
 - c. If meter displays "OL," proceed to step 6.
6. Reverse test leads.
 - a. If meter "Beeps" once, diode is installed backwards. Replace harness.
 - b. If meter still displays "OL," diode is defective (open). Replace harness.

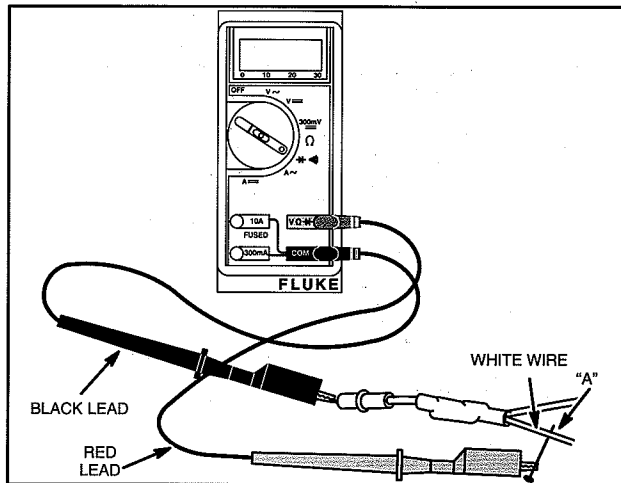

Fig. 19 – Diode Testing – Lighting Circuit

Note: Service replacement diode harnesses are available.

5 & 9 AMP REGULATED ALTERNATOR

The 5 & 9 amp regulated alternator systems provide AC current through a single lead to the regulator-rectifier. The regulator-rectifier converts the AC current to DC and regulates current to the battery. The charging rate will vary with engine RPM and temperature.

Alternator output (5 or 9 amp) is determined by the flywheel alternator magnet size. The stator and regulator-rectifier are the same for the 5 and 9 amp system.

The 5 & 9 amp regulated system and the Tri-Circuit system use the same stator.

WHEN CHECKING ALTERNATOR COMPONENTS, MAKE TESTS IN THE FOLLOWING SEQUENCE:

Alternator Output Test

Temporarily, disconnect stator wire harness from regulator-rectifier.

1. Insert RED test lead into $V \Omega \rightarrow$ receptacle in meter.
2. Insert BLACK test lead into **COM** receptacle in meter.
3. Rotate selector to $V \sim$ (AC volts) position.
4. Attach RED test lead clip to output terminal, Fig. 20.

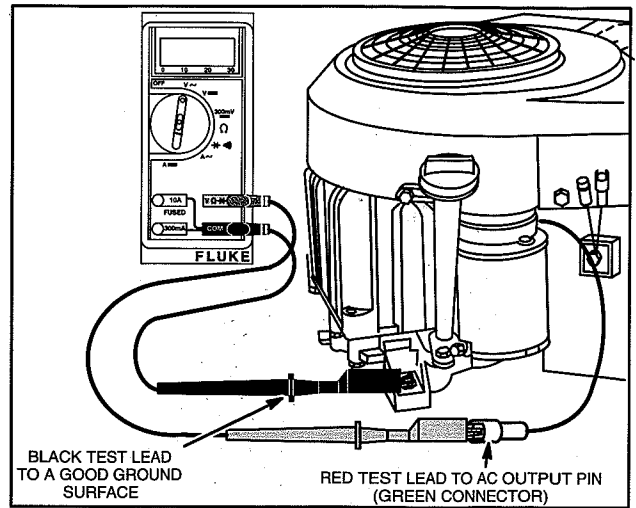

Fig. 20 – Testing AC Output

5. Attach BLACK test lead clip to engine ground.
6. With the engine running at 3600 RPM, AC output should be no less than:

28 Volts AC – 5 Amp System
40 Volts AC – 9 Amp System

7. If no or low output is found, replace the stator.

Test Regulator-Rectifier

Note: Regulator-rectifier will not function unless it is grounded to engine. Make sure the regulator-rectifier is securely mounted to engine.

When testing regulator-rectifier for amperage output, a 12 volt battery with a minimum charge of 5 volts is required. There will be no charging output if battery voltage is below 5 volts.

Note: Connect test leads before starting engine. Be sure connections are secure. If a test lead vibrates loose while engine is running, the regulator-rectifier may be damaged.

Connect stator wire harness to regulator-rectifier.

1. Insert RED test lead into 10 A receptacle in meter.
2. Insert BLACK test lead into **COM** receptacle in meter.

3. Rotate selector to $A \text{ ---}$ (DC amps) position.
4. Attach RED test lead clip to red DC output terminal on regulator-rectifier, Fig. 21.

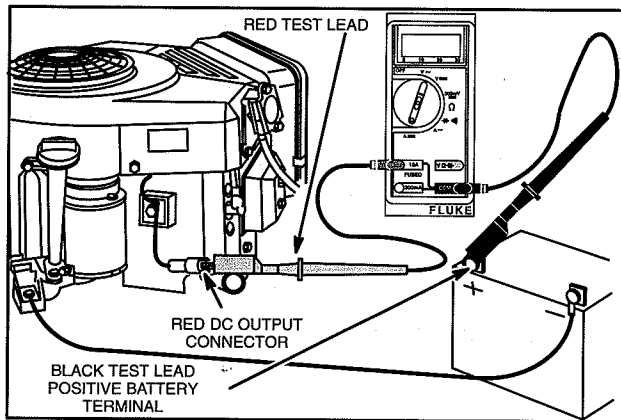

Fig. 21 – Testing Regulator-Rectifier

5. Attach BLACK test lead clip to positive (+) battery terminal.
6. With the engine running at 3600 RPM. The output should be:

- * 3 – 5 Amps – 5 Amp System
- * 3 – 9 Amps – 9 Amp System

* Depending upon battery voltage. For example, if the battery voltage was below 11 volts, the output reading would be 5 or 9 amps, depending upon the alternator system being tested. If battery voltage is at its maximum, the amperage will be less.

7. If no or low output is found, be sure that regulator-rectifier is grounded properly and all connections are clean and secure. If there is still no or low output, replace the regulator-rectifier.

10 & 16 AMP REGULATED ALTERNATOR

The 10 or 16 amp regulated alternator system provides AC current through two output leads to the regulator-rectifier. The regulator-rectifier converts the AC current to DC, and regulates the current to the battery. The charging rate will vary with engine RPM and temperature.

Alternator output (10 or 16 amp) is determined by flywheel alternator magnet size. Therefore, stator and regulator-rectifier are the same for the 10 and 16 amp system.

WHEN CHECKING THE ALTERNATOR COMPONENTS, MAKE THE TESTS IN THE FOLLOWING SEQUENCE:

Alternator Output Test

Temporarily, disconnect stator wire harness from regulator-rectifier.

1. Insert RED test lead into $V \Omega \rightarrow$ receptacle in meter.
2. Insert BLACK test lead into **COM** receptacle in meter.

3. Rotate selector to $V \sim$ (AC volts) position.
4. Insert RED and BLACK test lead probes into output terminals in yellow connector, as shown Fig. 22. (Meter test clip leads may be attached to either terminal.)

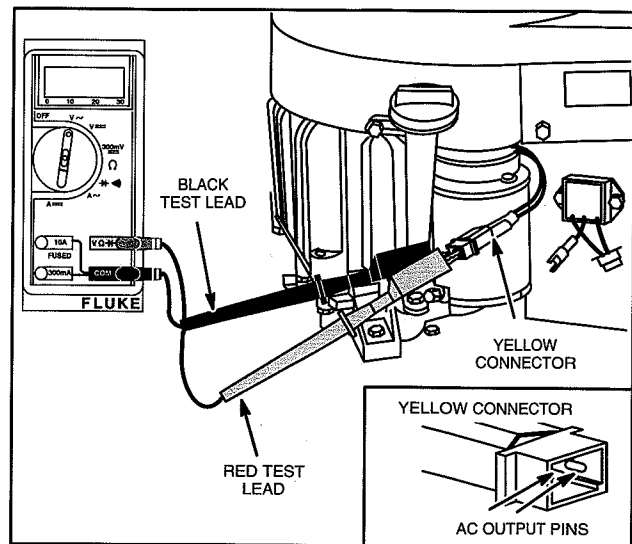

Fig. 22 – Testing AC Output

5. With the engine running at 3600 RPM output should be no less than:

- 20 Volts – 10 Amp System
- 30 Volts – 16 amp System

6. If no or low output is found, check for bare wires or any other obvious defects. If “shorted” leads are not visible, replace the stator.

Test Regulator-Rectifier

Regulator-rectifier will not function unless it is grounded to engine. Make sure the regulator-rectifier is securely mounted to engine.

When testing regulator-rectifier for amperage output, a 12 volt battery with a minimum charge of 5 volts is required. There will be no charging output if battery voltage is below 5 volts.

Note: Connect test leads before starting engine. Be sure connections are secure. If a test lead vibrates loose while engine is running, the regulator-rectifier may be damaged.

Testing Regulator-Rectifier 10 And 16 Amp System

To avoid blowing fuse in meter when testing DC output of 16 amp system the DC Shunt, Tool #19359 is required.

The DC Shunt **must** be installed on the **negative** (-) terminal of the battery, Fig. 23. All connections must be clean and tight for correct amperage readings.

Connect stator wire harness to regulator-rectifier.

1. Install shunt on negative battery terminal.

2. Insert RED test lead into $V \Omega \rightarrow +$ receptacle in meter and connect to RED post terminal on shunt, Fig. 23.
3. Insert BLACK test lead into **COM** receptacle in meter and connect to BLACK post terminal on shunt.
4. Rotate selector to **300mV** \equiv position.

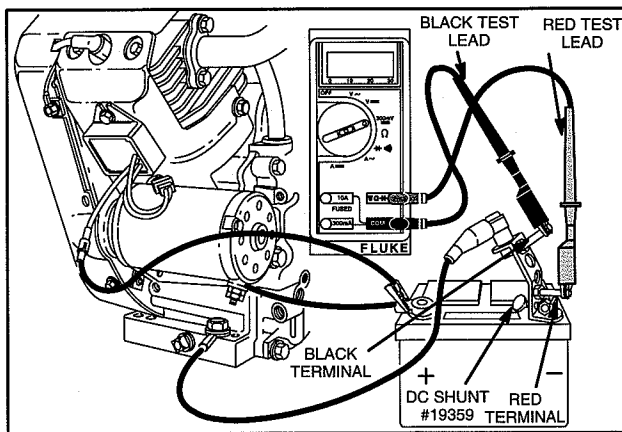

Fig. 23 – Testing Regulator-Rectifier 16 Amp System With DC Shunt

5. With the engine running at 3600 RPM, the output should be:

- * 3 – 10 Amps – 10 Amp System
- * 3 – 16 Amps – 16 Amp System

* Depending upon battery voltage. For example, if the battery voltage was below 11 volts, the output reading would be 16 amps. If battery voltage is at its maximum, the amperage will be less.

6. If no or low output is found, be sure that regulator-rectifier is grounded properly and all connections are clean and secure. If there is still no or low output, replace the regulator-rectifier.

Regulator-Rectifier With Charge Indicator

Regulator-rectifier Part #493219, Fig. 24, is used by some equipment manufacturers that have a charging indicator light instead of an ammeter. In addition to the red DC output wire, the regulator-rectifier is equipped with a blue wire which is used to activate a charging indicator light when battery voltage is below 12 volts.

The charging indicator light should light when the key switch is in the ON position; engine not running. With engine running, the charging indicator light should go out, indicating that the charging circuit is operating, providing that battery voltage is above 12 volts.

The charge indicator light and all wiring is supplied by the equipment manufacturer. See typical wiring diagram, page 13.

DC charging output values and test procedures are the same as those listed for the 10 amp or 16 amp system.

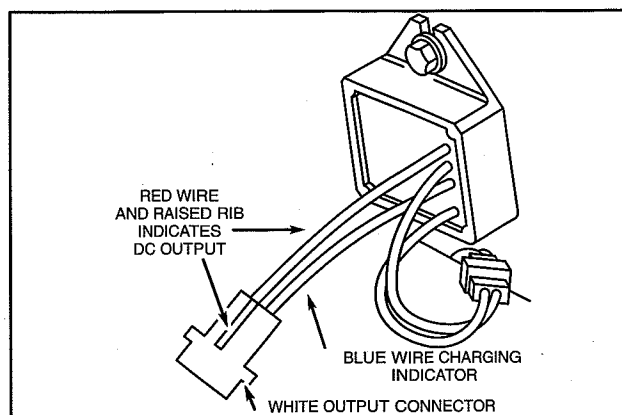
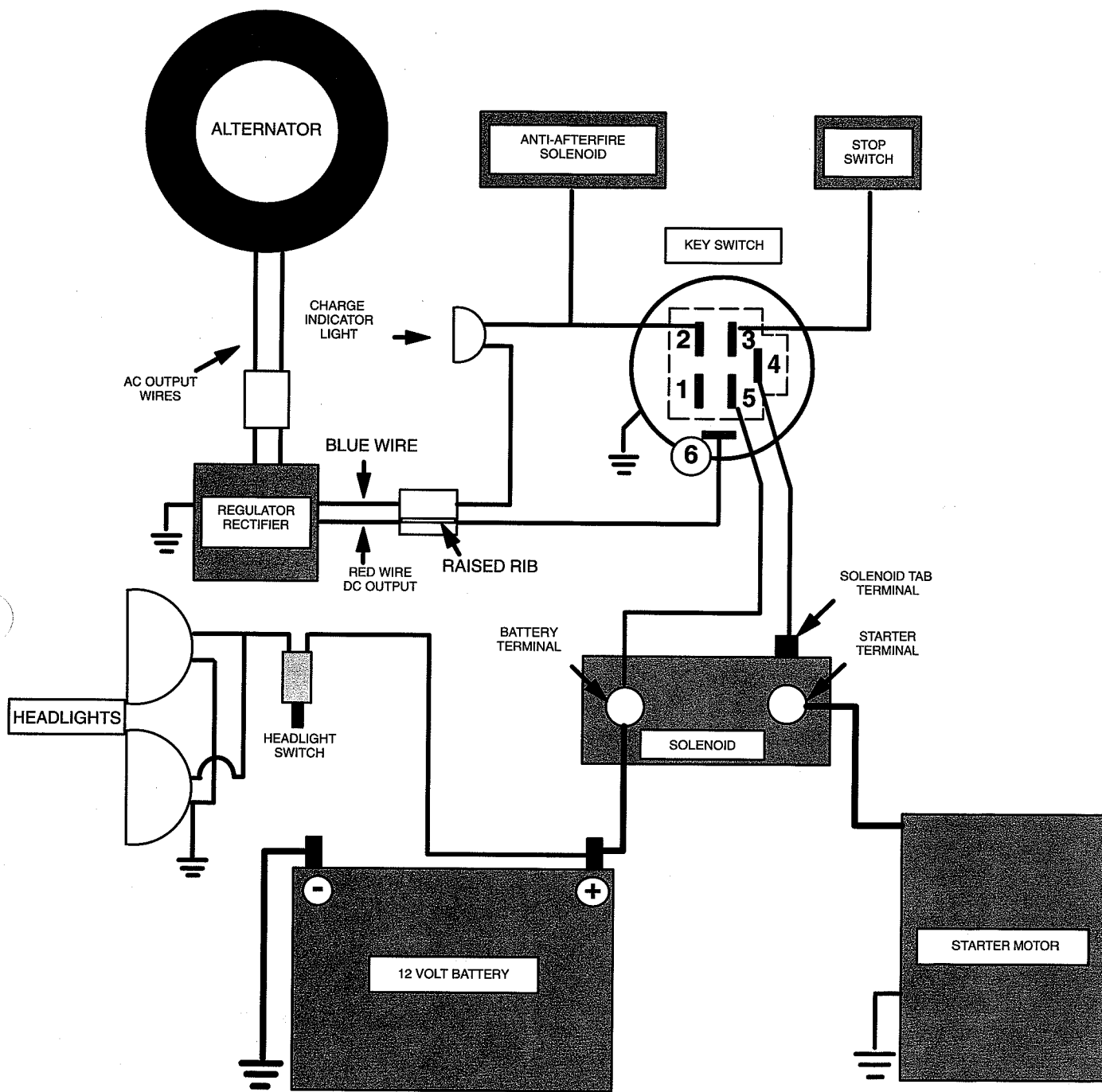

Fig. 24 – 493219 Regulator / Rectifier

Typical 16 Amp Regulated Alternator Wiring Diagram – 6 Pole Switch With Charge Indicator Light



7

Key Switch Test

| Switch Position | Continuity |
|-----------------|------------|
| 1. OFF | *1 + 3 + 6 |
| RUN | 2+5 + 6 |
| START | 2 + 4+5 |

* TERMINAL 1 GROUNDED INTERNALLY TO KEY SWITCH CASE

| Terminal No. | Function |
|--------------|--|
| 1 | To Ground (used only with insulated panel) |
| 2 | To Carburetor Solenoid. |
| 3 | To Stop Switch Terminal On Engine |
| 4 | To Solenoid (tab terminal) |
| 5 | To Battery (battery terminal on solenoid) |
| 6 | To Alternator (DC Output) |

Testing Charge Indicator

It is important that the test procedure be done in a systematic manner to identify whether the problem is related to the regulator/rectifier or the charging indicator wiring system. Follow test procedure in the sequence listed.

A known good battery is required for this test.

BEFORE TESTING THE CHARGING INDICATOR SYSTEM, TEST THE ALTERNATOR AND REGULATOR/RECTIFIER FOR CORRECT OUTPUT.

Note: Output values are the same as the 10 amp and 16 amp system.

Symptom: Charge Indicator Light Will Not Light – Key Switch On – Engine Not Running

A jumper wire is required for this test.

Make sure key switch is in OFF position before connecting jumper wire.

IMPORTANT: Before disconnecting output harness from connector, mark or identify the charging indicator wire in the output harness. If jumper wire contacts charging output wire during test, while key switch is in ON position, wiring harness may be damaged.

1. Disconnect output harness at white connector.
2. Attach one end of jumper wire to a good ground.
3. Attach other end of jumper wire to charge indicator terminal in harness connector, Fig. 25.
 - a. Turn keyswitch to ON position.
 - b. If bulb lights, charge indicator wiring system is OK. Replace regulator/rectifier.
 - c. If bulb does not light, replace bulb.
 - d. If new bulb does not light, the problem must be a broken wire (open circuit) in charging indicator circuit. Refer to typical wiring diagram, page 13.

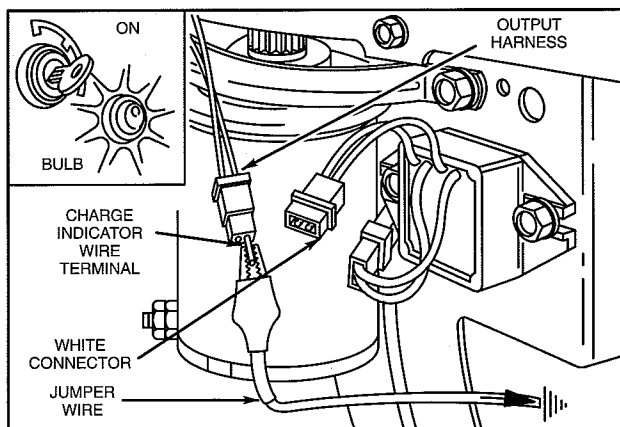

Fig. 25 – Testing Charge Indicator

Symptom: Charge Indicator Light Stays On – Engine Running

Note: Indicator light will remain on if battery voltage is below 12 volts.

1. Check indicator light wiring.
 - a. If wiring is grounded, light will remain on when engine is running.
 - b. If wiring is OK, replace regulator/rectifier.

20 AMP REGULATED ALTERNATOR

The 20 amp regulated alternator system provides AC current through two output leads to the regulator-rectifier. The regulator-rectifier converts the AC current to DC, and regulates the current to the battery. The charging rate will vary with engine RPM and temperature.

The stator, regulator-rectifier and flywheel are NOT interchangeable with any other alternator system.

WHEN CHECKING THE ALTERNATOR COMPONENTS, MAKE THE TESTS IN THE FOLLOWING SEQUENCE:

Alternator Output Test

Temporarily, disconnect stator wire harness from regulator-rectifier.

1. Insert RED test lead into $V \Omega \rightarrow$ receptacle in meter.
2. Insert BLACK test lead into **COM** receptacle in meter.
3. Rotate selector to $V \sim$ (AC volts) position.



CAUTION: ATTACH METER TEST LEADS TO AC OUTPUT TERMINALS IN WHITE CONNECTOR (YELLOW WIRES) BEFORE STARTING ENGINE. IF STATOR IS GROUNDED (DEFECTIVE), AND METER TEST LEADS CONTACT CENTER DC OUTPUT PIN IN WHITE CONNECTOR (RED WIRE), ARCING MAY OCCUR WHICH MAY DAMAGE WIRING.

4. Attach RED and BLACK test lead probes to AC output terminals in white connector (yellow wires), as shown in Fig. 26. (Meter test clip leads may be attached to either AC output terminal.)

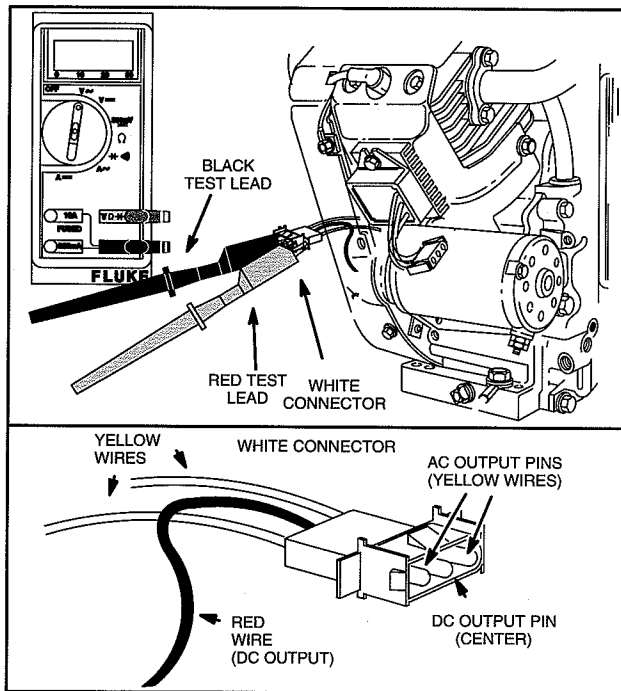

Fig. 26 – Testing AC Output

5. With the engine running at 3600 RPM output should be no less than:

26 Volts – 20 Amp System

6. If no or low output is found. check for bare wires or any other obvious defects. If “shorted” leads are not visible, replace the stator.

Testing DC Output Charging Wire

A simple test may be performed to test the DC output charging wire circuit. If a problem exists in the wiring it can be corrected before testing regulator-rectifier.

Leave stator wire harness disconnected from regulator-rectifier.

Equipment keyswitch must be in OFF position.

1. Insert RED test lead into $V \Omega \rightarrow$ receptacle in meter.
2. Insert BLACK test lead into **COM** receptacle in meter.
3. Rotate selector to **300mV** \equiv (DC volts) position.
4. Attach RED test lead probe to DC output terminal in white connector (red wire), Fig. 26.
5. Attach BLACK test lead probe to negative battery terminal.
6. Turn equipment keyswitch to ON position. Meter should display battery voltage.
7. If meter does not display battery voltage, check for blown fuse or broken or shorted wires.

Testing Regulator-Rectifier 20 Amp System

To avoid blowing fuse in meter when testing DC output of 16 amp system the DC Shunt, Tool #19359 is required.

The DC Shunt **must** be installed on the **negative (-)** terminal of the battery, Fig. 27. All connections must be clean and tight for correct amperage readings.

Connect stator wire harness to regulator-rectifier.

1. Install shunt on negative battery terminal.
2. Insert RED test lead into $V \Omega \rightarrow$ receptacle in meter and connect to RED post terminal on shunt, Fig. 27.
3. Insert BLACK test lead into **COM** receptacle in meter and connect to BLACK post terminal on shunt.
4. Rotate selector to **300mV** \equiv position.

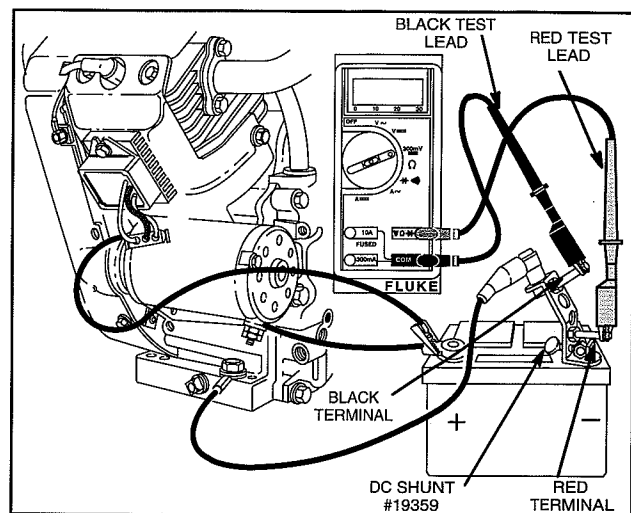

Fig. 27 – Testing Regulator-Rectifier 20 Amp System With DC Shunt

5. With the engine running at 3600 RPM, the output should be:

*** 3 – 20 Amps – 20Amp System**

* Depending upon battery voltage and/or current draw on system.

6. If no or low output is found, be sure that regulator-rectifier is grounded properly and all equipment connections are clean and secure. If there is still no or low output, replace the regulator-rectifier.

BATTERIES

The battery is of the 12 volt, lead acid, wet cell type. This type is available as a maintenance free or a dry charged battery.

The maintenance-free battery is filled with electrolyte at the time of manufacture. The level of electrolyte cannot be checked, Fig. 28.

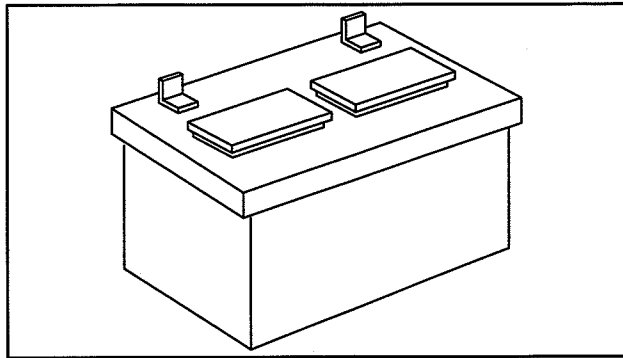

Fig. 28 – Typical Wet Charge Battery

The dry charged battery is manufactured with fully charged plates. Electrolyte must be added at the time that the battery is placed in service. Before activating a dry charged battery, read and follow the manufacturer's recommended procedure.

Recommended battery sizes range from a minimum 30 ampere hour for warm temperature service to 50 ampere hour in coldest service.

WARNING: BATTERIES PRODUCE HYDROGEN, AN EXPLOSIVE GAS. DO NOT STORE, CHARGE OR USE A BATTERY NEAR AN OPEN FLAME OR DEVICES WHICH UTILIZE A PILOT LIGHT OR CAN CREATE A SPARK.

Installation

1. Before installing battery, connect all equipment to be operated. Fig. 29.
2. Place battery in holder with a flat base. Tighten hold downs evenly until snug. DO NOT overtighten.
3. Connect positive terminal to positive post FIRST to prevent sparks from accidental grounding. Tighten connectors securely.
4. Connect negative terminal to negative battery terminal. Tighten connectors securely.

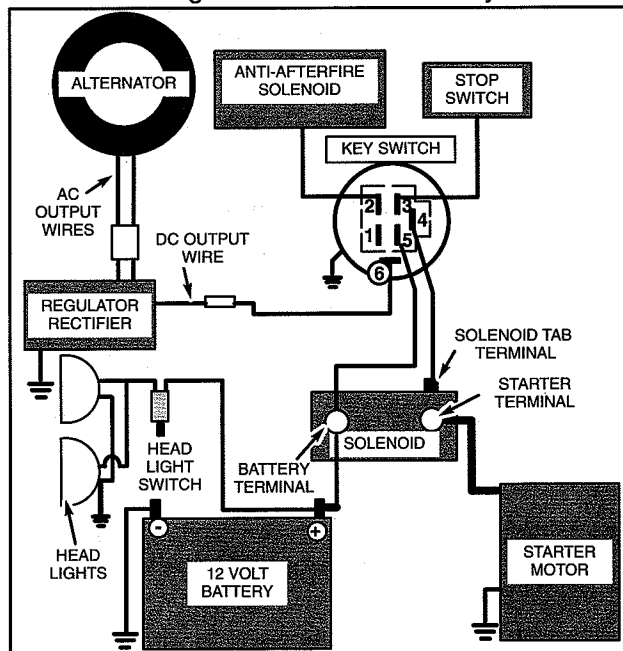

Fig. 29 – Typical 12 V Wiring Diagram

Checking Battery

1. Physical check – clean if necessary.
 - a. Corrosion
 - b. Dirt
 - c. Terminal and clamps (secure – good conditions)
2. Bring battery to full charge.

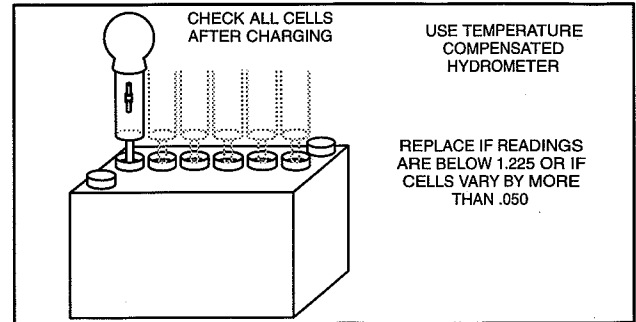

Fig. 30 – Checking 12 V Battery Cells (Lead Acid, Wet Cell, With Fill Caps)

DO NOT EXCEED CHARGE RATE OF 1/10 AMPERE FOR EVERY AMPERE OF BATTERY RATING. Consult battery manufacturer for charging recommendations. Overcharging may cause battery failure.

- a. Use a taper charger (automatically reduces charge rate).
 - b. Fill battery cells with distilled water or tap water (unless maintenance free type) after charging (for batteries that have been in service).
- Note: If battery gets "hot" to the touch or is spitting acid (gassing) excessively, unplug charger periodically.**

3. With battery fully charged, check specific gravity readings (unless maintenance free type) of each cell with a Battery Hydrometer and record readings (Fig. 30).

All readings should be above 1.250 (compensating for temperature). If specific gravity readings varied .050 or if ALL cells read less than 1.225, replace battery.

Section 8 Lubrication

Section Contents

| | Page |
|---|------|
| DESCRIPTION | 3 |
| CHANGE OIL | 3 |
| CHANGE OIL FILTER | 3 |
| OIL FILL TUBE AND DIPSTICK | 4 |
| CHECK PRESSURE SWITCH | 4 |
| CHECK OIL PRESSURE | 4 |
| CRANKCASE BREATHER | 5 |
| Remove Breather – Engine Models 290000 – 351000 | 5 |
| Checking Breather – Reed Valve Type | 5 |
| Checking Breather – Fiber Disc Type | 5 |
| Install Breather – Reed Valve Type | 6 |
| Install Breather – Fiber Disc Type | 6 |
| Remove Breather – Engine Models 380000 | 6 |
| Checking Breather – Engine Models 380000 | 7 |
| Install Breather – Engine Models 380000 | 7 |
| Inspect Breather Tube – All Models | 7 |
| REMOVE OIL PUMP | 8 |
| Remove Oil Pump – All Models | 8 |
| Disassemble Oil Pump – Horizontal Crankshaft Models | 8 |
| Inspect Oil Pump | 9 |
| Assemble Oil Pump | 9 |
| Install Oil Pump – Horizontal Crankshaft Models | 9 |
| Install Oil Pump – Vertical Crankshaft Models | 10 |
| Install Crankcase Cover Or Sump | 10 |
| ADJUST GOVERNOR | |
| Static Governor Adjustment | 11 |
| Install Push Rods | 11 |
| OIL COOLER | 11 |

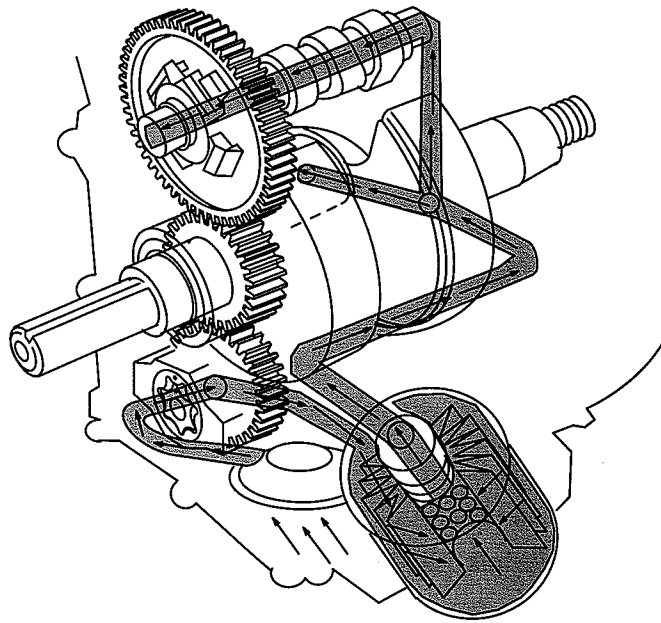

Fig. 1 – Full Pressure Lubrication System – Horizontal Crankshaft

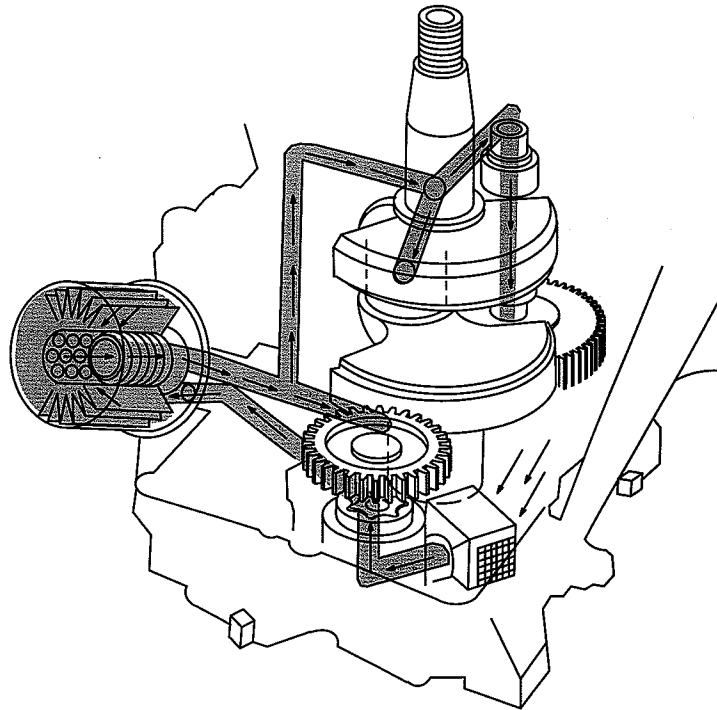
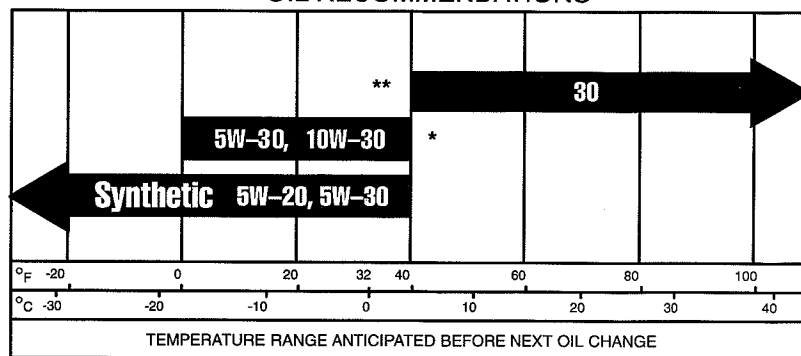

Fig. 2 – Full Pressure Lubrication System – Vertical Crankshaft

OIL RECOMMENDATIONS



Use a high quality detergent oil classified "For Service SE" or higher. Use no special additives with recommended oils.

DESCRIPTION

Briggs & Stratton Vanguard™ OHV V-Twins use a full pressure lubrication system with an oil filter. The gear driven oil pump draws oil from a screened oil pickup in the sump and pumps the oil through the oil filter.

The filtered oil flows through oil galleries in the sump and is distributed to the main bearings, connecting rod bearings and camshaft bearings. Engine oil pressure will vary with oil viscosity, ambient air temperature differences, operating temperatures and engine load. Follow the oil recommendation shown above.

Oil Pressure – @ 70° F (21° C): 10 ~ 50 psi
(0.7 ~ 3.5 Bar)

A pressure relief valve limits the maximum oil pressure in the system.

An optional oil pressure switch is available. The switch may be used to activate a warning device if oil pressure drops below approximately 5 psi (.35 Kgcm²). The warning device and all wiring is supplied by the equipment manufacturer.

CHANGE OIL

Change oil after first eight (8) hours of operation.

Thereafter, change oil every fifty (50) hours of operation. Change oil more often if engine is operated in dirty or dusty conditions or if engine is operated under heavy loads or in high ambient air temperatures.

Remove oil drain plug and drain oil while engine is still warm, Fig. 3 and Fig. 4. Install and torque drain plug to 14.0 Nm (125 in. lbs.).

Remove dipstick and refill slowly with new oil of proper service classification and grade.

Oil Capacity: 4.0 pints (1.9 liters) with filter
3-3/4 pints (1.8 liters) without filter

Fill to FULL mark on dipstick. DO NOT OVERFILL. When checking oil level, dipstick must be screwed all the way in for accurate readings.

Overfilling sump can cause a smoking or overheating condition due oil foaming. Start and run engine to check for oil leaks.

CHANGE OIL FILTER

Replace oil filter every 100 hours or every season.

Before installing new filter, lightly oil filter gasket with fresh clean engine oil.

Note: Hand tighten 1/2 turn after gasket contacts mounting surface.

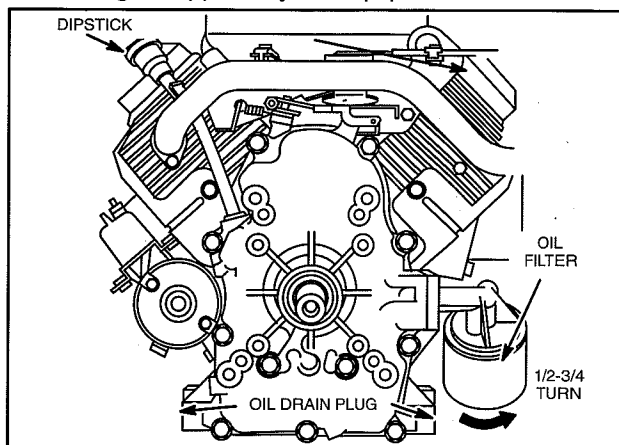

Fig. 3 – Horizontal Crankshaft

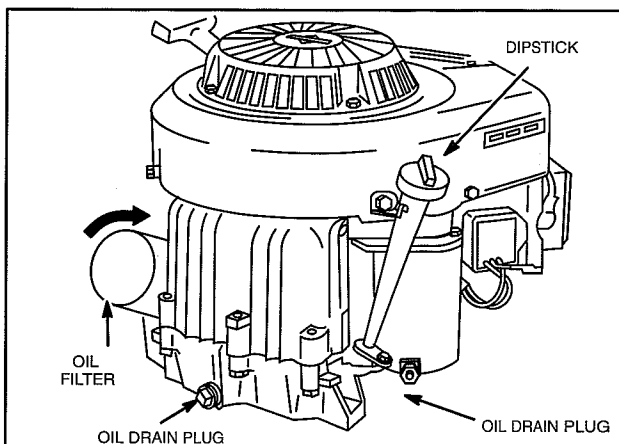

Fig. 4 – Vertical Crankshaft

OIL FILL TUBE AND DIPSTICK

The oil fill tube and the dipstick are equipped with "O"-rings and/or a grommet for proper sealing, Fig. 5.

Note: A leak at the seal between the tube and sump, or at the seal at the upper end of the dipstick, can result in a loss of crankcase vacuum and a discharge of oil or smoke through the muffler.

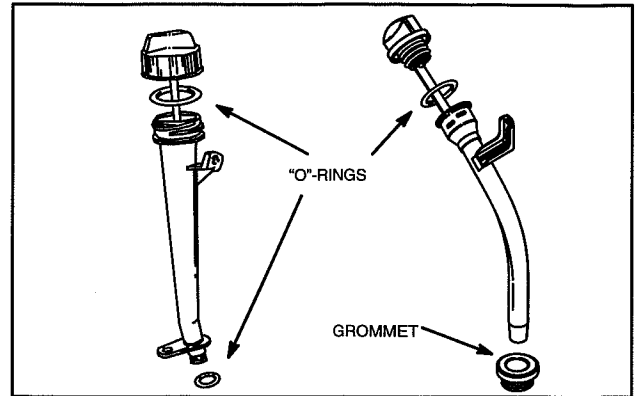

Fig. 5 – Oil Fill Tube And Dipstick

CHECK PRESSURE SWITCH

Use Digital multimeter, Tool #19390. Set meter to test for continuity.

Remove pressure switch for testing. Connect one continuity tester lead to the switch terminal and the other tester lead to the metal body of the switch, Fig. 6. The tester should indicate continuity when no pressure is applied to the switch. The switch should open (no continuity) when approximately 4.5 PSI (0.3 Bar) is applied. Replace the switch if test results are not to specification.

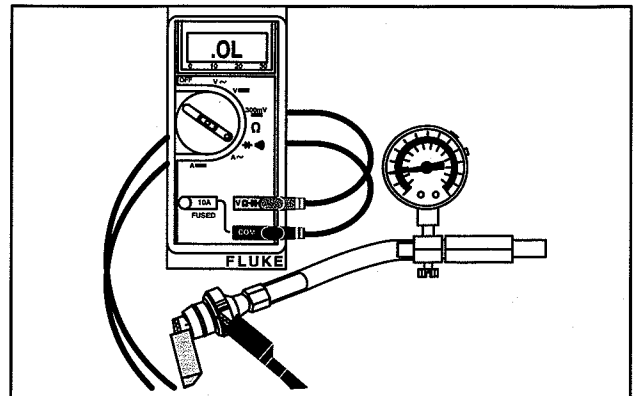

Fig. 6 – Checking Pressure Switch

CHECK OIL PRESSURE

1. Oil level must be between the LOW and FULL mark on dipstick. If oil level is low, check for leaks and add to FULL mark.
2. Remove pressure switch or 1/8" NPTF plug in oil filter adapter.
3. Install oil pressure gauge, Fig. 7.
4. Start and run engine for approximately 5 minutes.
5. Check oil pressure at 3000 RPM.

**Oil Pressure @ 70° F (21° C): 10 ~ 50 psi
(0.7 ~ 3.5 Bar)**

See chart below for troubleshooting guide.

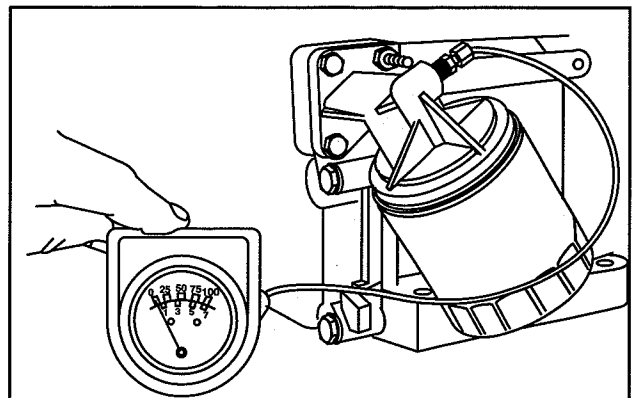

Fig. 7 – Checking Oil Pressure

| Low Oil Pressure |
|---------------------------------|
| Engine RPM Too Low |
| Wrong Viscosity or Diluted Oil |
| Low Oil Level |
| Broken Pressure Relief Spring |
| Missing Pressure Relief Plunger |
| Worn Bearings |
| Damaged Or Defective Oil Pump |

| High Oil Pressure |
|-------------------------------|
| Wrong Viscosity Oil |
| Plugged Oil Galleries |
| Stuck Pressure Relief Plunger |

CRANKCASE BREATHER

The engine utilizes a breather valve to control and maintain a vacuum in the crankcase. The breather vents crankcase vapors through the air cleaner.

Engine Models 290000 – 351000

The breather on models 290000 – 351000 is located on the valley between cylinder number one and two.

Two styles of breathers are used, Fig. 8. The current style breather uses a reed valve to maintain crankcase vacuum. Early style breathers contain a fiber disc type valve. The breather mounting screw for the current style and early style breather is NOT interchangeable.

Engine Models 380000

The breather used on models 380000 is located in the valve cover of number 2 cylinder, Fig. 9. The breather uses a reed valve to maintain crankcase vacuum. The reed valve is replaceable.

Remove Breather Engine Models 290000 – 351000

Remove the air cleaner assembly. See Section 3.
Remove breather. Discard gasket, Fig. 10.

Checking Breather – Reed Valve Type

The reed valve is spring loaded and must make a complete seal around the vent hole in breather body, Fig. 11. Check to see that reed valve is not deformed. **DO NOT USE FORCE ON REED VALVE.**

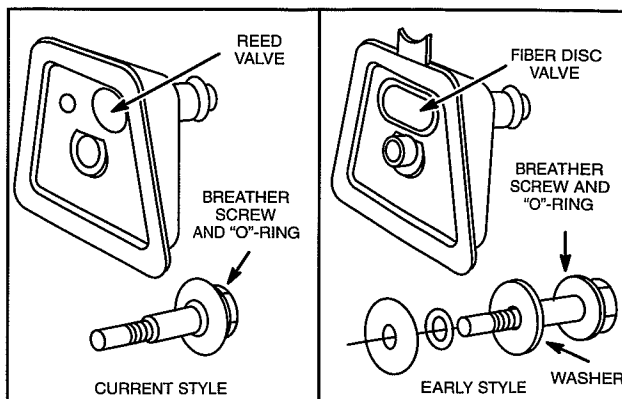

Fig. 8 – Crankcase Breather – Models 290000 – 351000

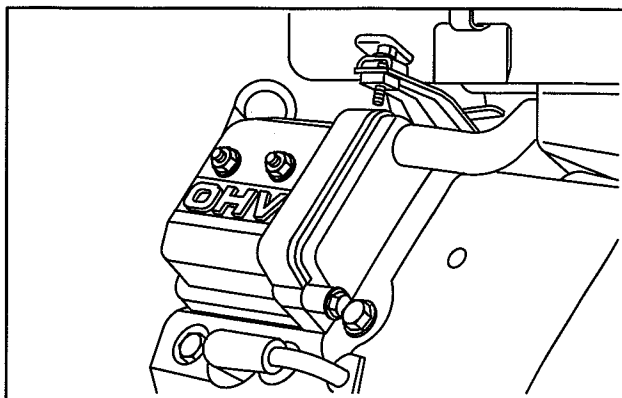

Fig. 9 – Crankcase Breather – Model 380000

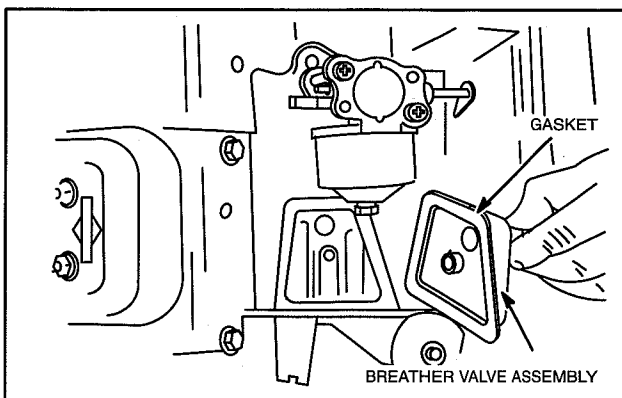

Fig. 10 – Remove Breather

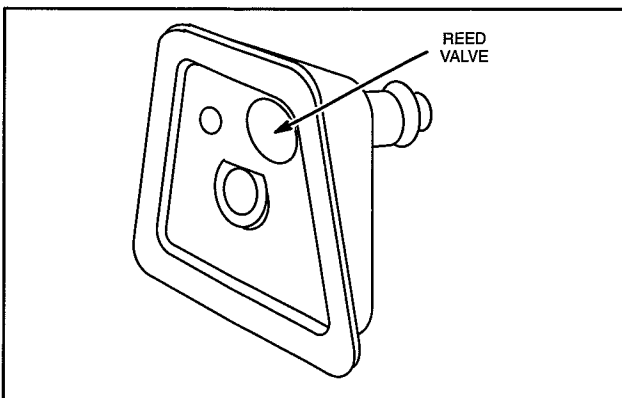

Fig. 11 – Check Breather

Checking Breather – Fiber Disc Type

If the fiber disc valve is stuck or binding, the breather must be replaced. A 1.14 mm (.045") wire gauge should not enter the spacer between the fiber disc valve and body, Fig. 12.

DO NOT USE FORCE ON FIBER DISC.

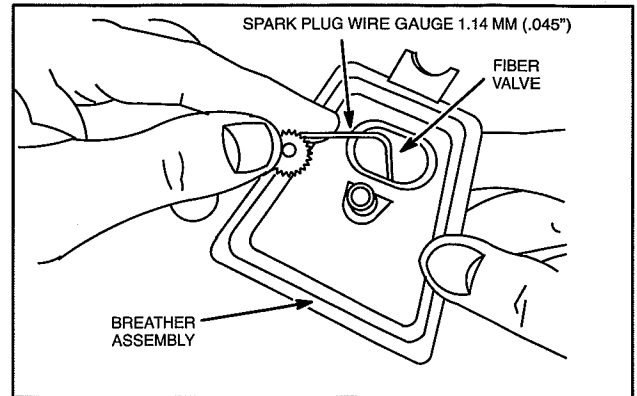

Fig. 12 – Check Breather

Install Breather – Reed Valve Type

Place breather on gasket. Assemble large "O"-ring onto mounting screw and install screw, Fig. 13.

Torque screw to 3.0 Nm (30 in. lbs.).

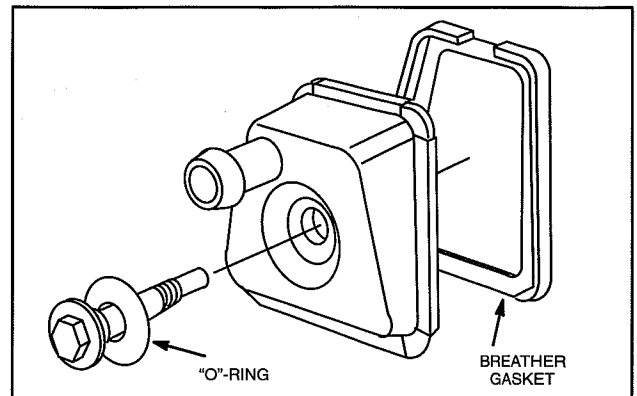

Fig. 13 – Install Breather

Install Breather – Fiber Disc Type

Place breather on gasket. Place large "O"-ring on breather. Assemble washer and small "O"-ring to screw and install screw, Fig. 14.

Torque screw to 3.0 Nm (30 in. lbs.).

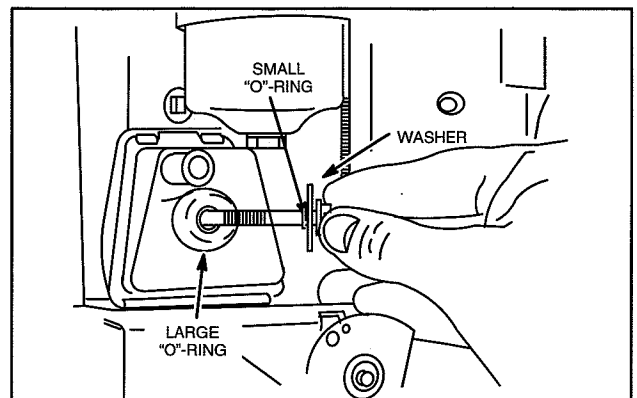

Fig. 14 – Install Breather

Remove Breather – Engine Models 380000

Remove two screws and separate breather assembly from valve cover, Fig. 15.

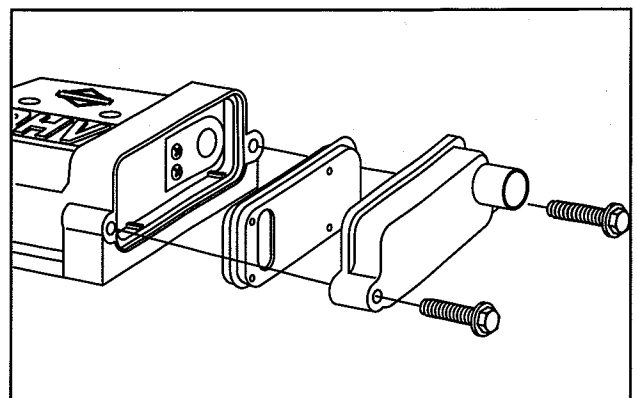

Fig. 15 – Remove Breather

Checking Breather – Engine Models 380000

1. Remove two screws, reed stop and reed valve.
2. Place reed valve on flat surface.
3. Check reed valve for distortion with feeler gauge, Fig. 16.

Maximum Distortion: 0.25 mm (.010")

Replace reed valve if not to specification.

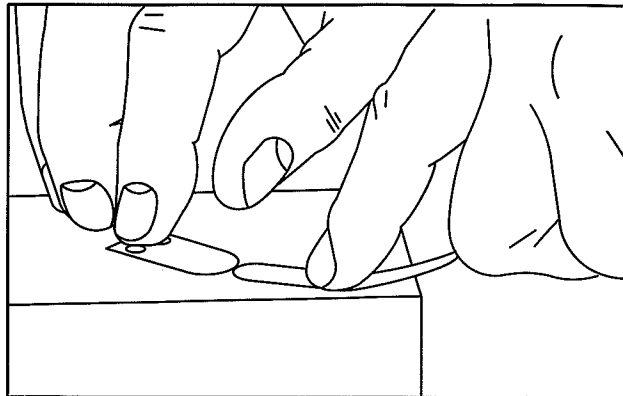

Fig. 16 – Check Reed Valve

Check reed stop height in the following manner.

1. While holding mounting surface of reed stop on flat surface, use the following drills to check reed stop height, Fig. 17.
2. Use #29 drill as GO gauge.
3. Use #24 drill as NO GO gauge.

Replace reed stop if not to specification.

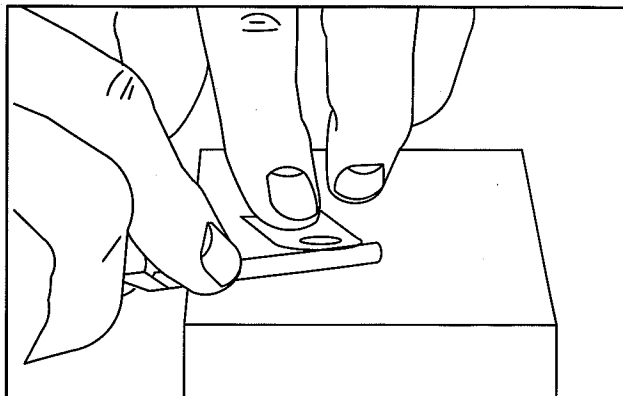

Fig. 17 – Check Reed Stop

Install Breather – Engine Models 380000

1. Assemble reed valve and reed stop to breather body, Fig. 18. Tighten screws securely.

Note: Holes in reed and reed stop are offset. Assemble so that holes are aligned.

2. Assemble baffle and cover to valve cover with new gasket.
3. Torque screws to 3.0 Nm (30 in. lbs.).

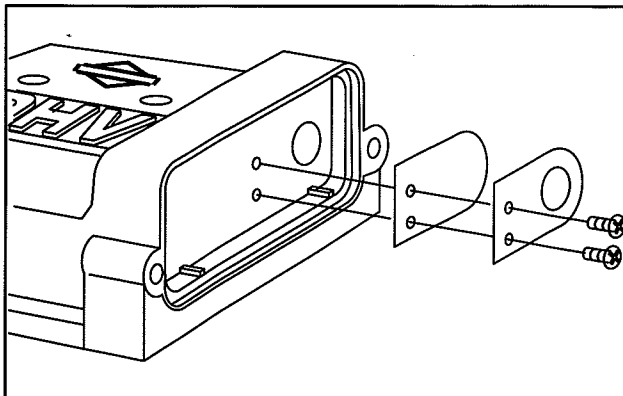

Fig. 18 – Install Breather

Inspect Breather Tube – All Models

Check breather tube(s) for cracks or holes or hardening, Fig. 19. Replace if damaged.

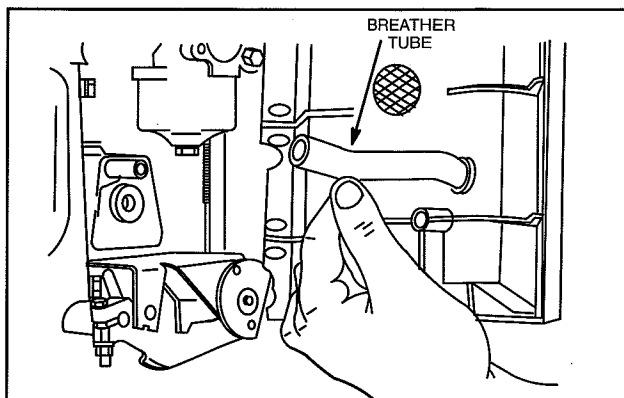

Fig. 19 – Inspect Breather Tube

REMOVE OIL PUMP

Drain oil and remove oil filter. Remove engine from equipment. Disconnect oil cooler lines at filter adapter (if equipped). Remove spark plugs. Remove valve covers and discard gaskets and seals.

1. Compress valve springs and remove push rods, Fig. 20.

Note: Mark push rods so that they may be reassembled in their original position. If push rods are mixed, it may be necessary to readjust valve clearance.

Exhaust valve push rods are aluminum.

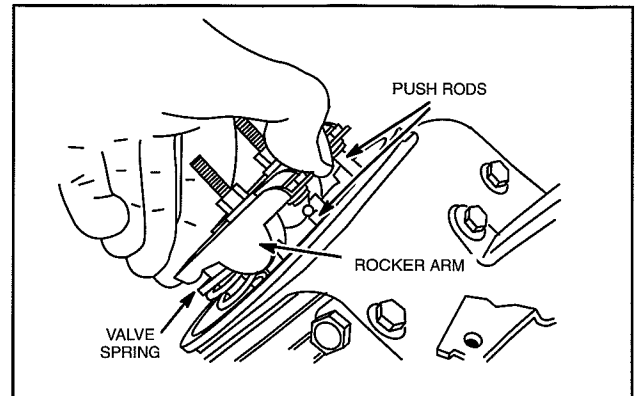

Fig. 20 – Compress Valve Springs

1. Disconnect governor link and spring at carburetor.
2. Disconnect governed idle spring (if equipped).
3. Loosen governor lever nut.
 - a. Remove governor lever from shaft, Fig. 21.

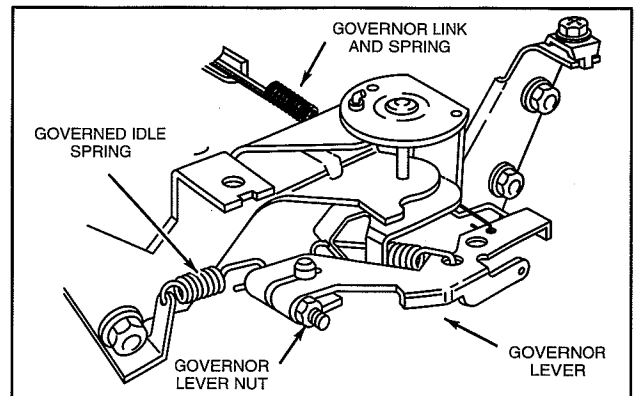

Fig. 21 – Remove Governor Lever

Remove rust, nicks or burrs from crankshaft.

4. Remove oil fill tube and dipstick assembly.
5. Remove crankcase cover or sump, Fig. 22.
 - a. Discard gasket and "O"-ring.

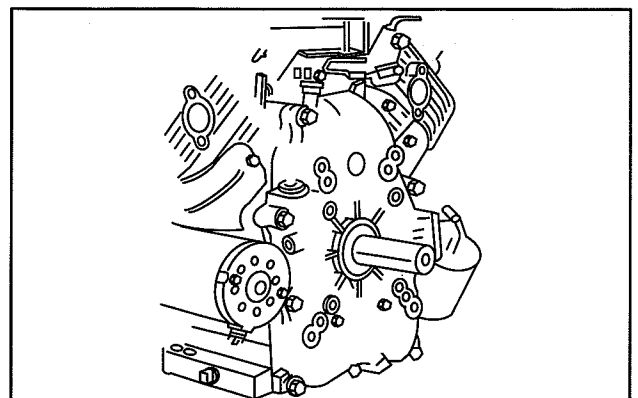

Fig. 22 – Remove Crankcase Cover

Remove Oil Pump – All Models

1. Remove two screws from crankcase cover or sump, Fig. 23.
2. Remove oil pump.
 - a. Discard "O"-rings.
3. Outer rotor of pump can be removed for inspection and cleaning.

With pump removed, oil pick-up screen may be removed for cleaning (vertical crankshaft models). No further disassembly is required for vertical crankshaft models.

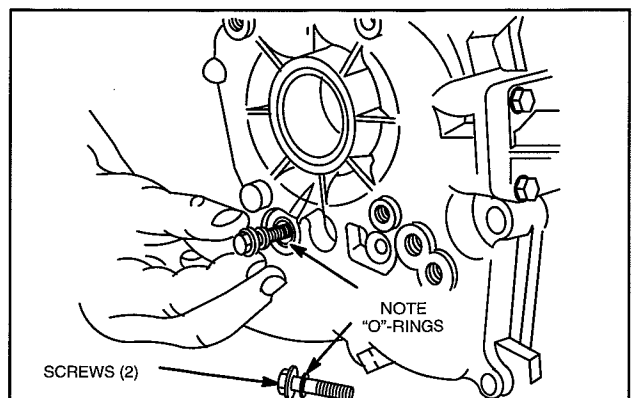

Fig. 23 – Remove Oil Pump

Disassemble Oil Pump – Horizontal Crankshaft Models

1. Remove two screws and oil pump gear baffle or windage plate, if equipped, Fig. 24.

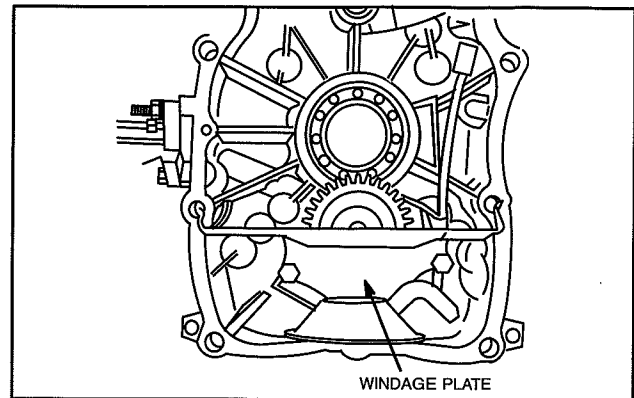

Fig. 24 – Remove Windage Plate

2. Remove oil pick-up tube and screen assembly, Fig. 25.
 - a. Discard "O"-ring.

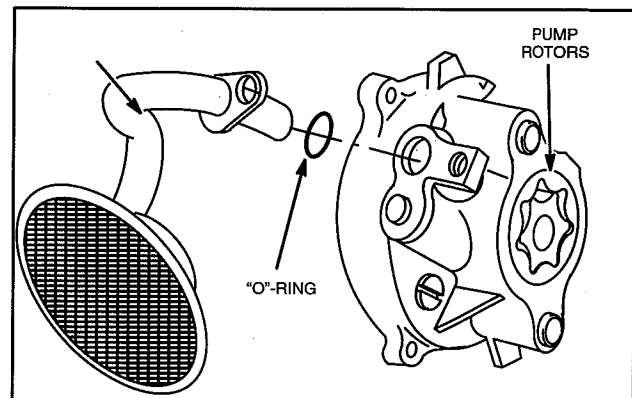

Fig. 25 – Remove Oil Pick Up Tube

Inspect Oil Pump

Inspect pump drive gear for obvious wear or chipped teeth. Inspect pump rotors, housing and crankcase cover or sump for scoring or wear. Replace as required.

Assemble Oil Pump

Lubricate outer rotor with oil and install in pump with dimples aligned, Fig. 26.

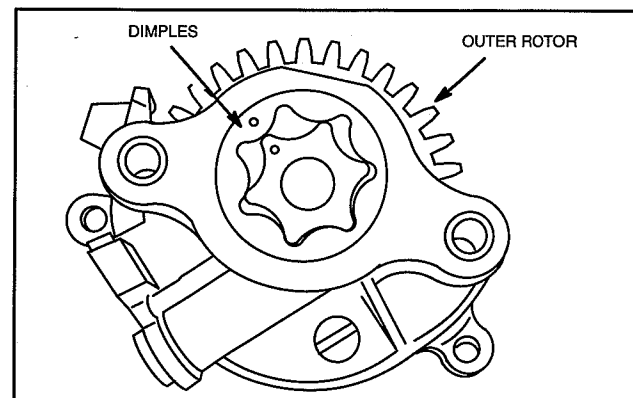

Fig. 26 – Inspect Oil Pump

Install Oil Pump – Horizontal Crankshaft Models

1. Assemble oil pick-up tube and screen assembly with new "O"-ring to pump.
 - a. Torque screw to 7.0 Nm (65 in. lbs.).
2. Assemble oil pump to crankcase cover with new "O"-rings, Fig. 27.
 - a. Torque screws to 7.0 Nm (65 in. lbs.).
3. Install oil pump gear baffle or windage plate, if equipped.
 - a. Torque screws to 7.0 Nm (65 in. lbs.).

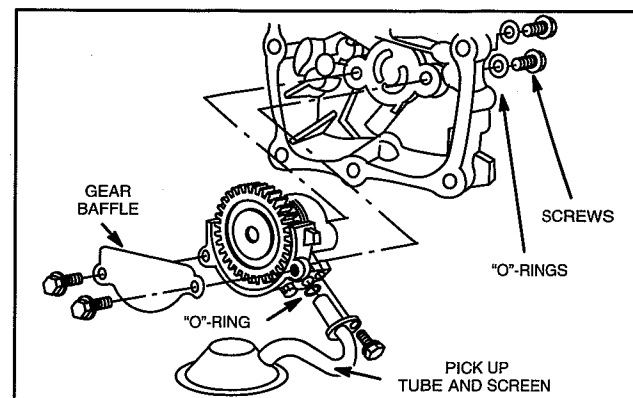

Fig. 27 – Install Oil Pump

Install Oil Pump – Vertical Crankshaft Models

1. Insert oil pick-up screen into slots in sump.
2. Assemble oil pump to sump with new “O”-rings, Fig. 28.

a. Torque screws to 7.0 Nm (65 in. lbs.).

Note: Boss on oil pump body holds pick-up screen in proper position.

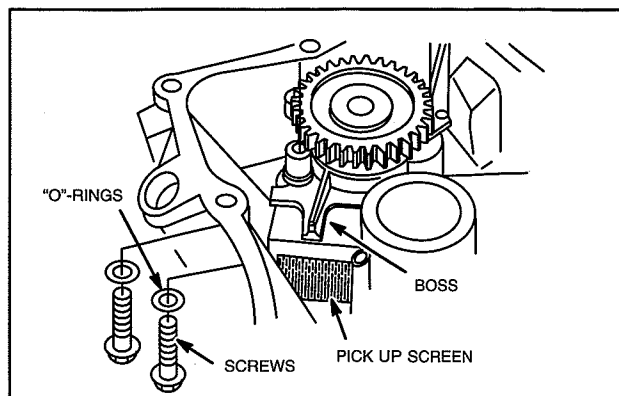

Fig. 28 – Install Oil Pump

Install Crankcase Cover Or Sump

1. Install new “O”-ring and gasket to crankcase.
2. Rotate governor shaft so that paddle rests against camshaft bearing support, Fig. 29.
3. Insert proper seal protector through oil seal.

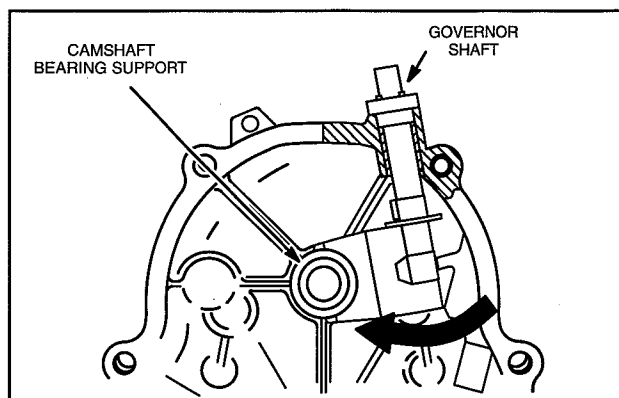

Fig. 29 – Position Governor Shaft

4. Install crankcase cover or sump.
 - a. Torque screws in sequence shown to 17.0 Nm (150 in. lbs.), Fig. 30.
5. Reinstall oil fill tube and dipstick assembly.

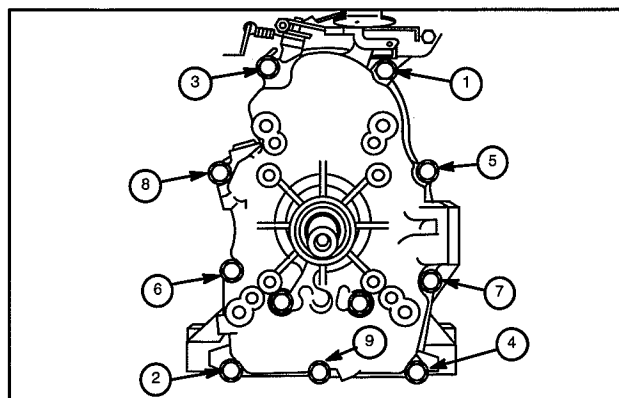

Fig. 30 – Install Crankcase Cover Or Sump

6. Reassemble governor lever to shaft, Fig. 31.
 - a. Reassemble governor link and spring at carburetor.
 - b. Reassemble governed idle spring.

DO NOT tighten nut at this time.

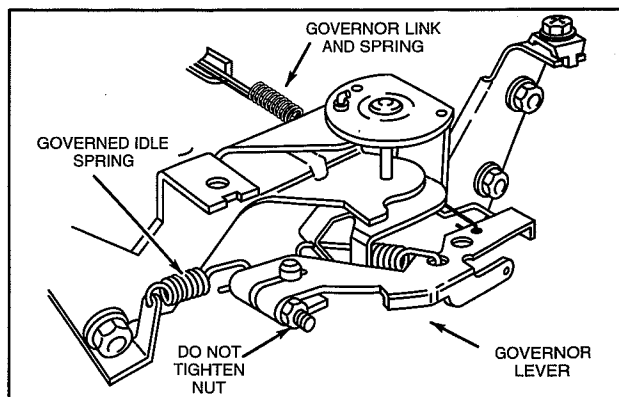

Fig. 31 – Install Governor Lever

ADJUST GOVERNOR



WARNING: BEFORE STARTING OR RUNNING ENGINE, STATIC ADJUSTMENT OF THE GOVERNOR MUST BE COMPLETED! FAILURE TO MAKE THE STATIC ADJUSTMENTS FIRST COULD RESULT IN ENGINE OVERSPEEDING WHICH MAY RESULT IN ENGINE DAMAGE, PROPERTY DAMAGE OR PERSONAL INJURY.

Static Governor Adjustment

1. With governor lever nut loose, push on governor lever until throttle is wide open. **Do not bend governor link or distort governor lever.**
2. Rotate governor shaft counter-clockwise as far it will go, Fig. 32.
 - a. Torque governor nut to 8.0 Nm (70 in. lbs.).
3. Install throttle and choke control cables and check for proper operation.

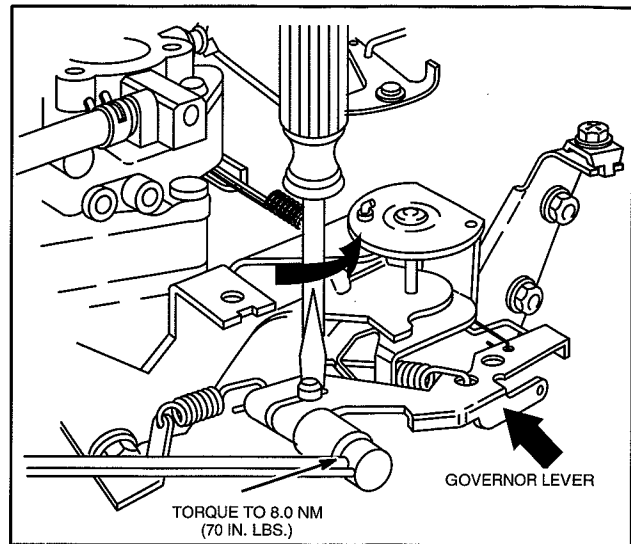

Fig. 32 – Static Governor Adjustment

Install Push Rods

1. Install push rods in their original position.
 2. Compress valve spring with rocker arm and insert push rod into rocker arm socket.
- Be sure push rods remain seated in recess in tappets.
3. Install valve covers with new gaskets and valve cover seals, Fig. 33.
 - a. Torque nuts to 3.0 Nm (25 in. lbs.).

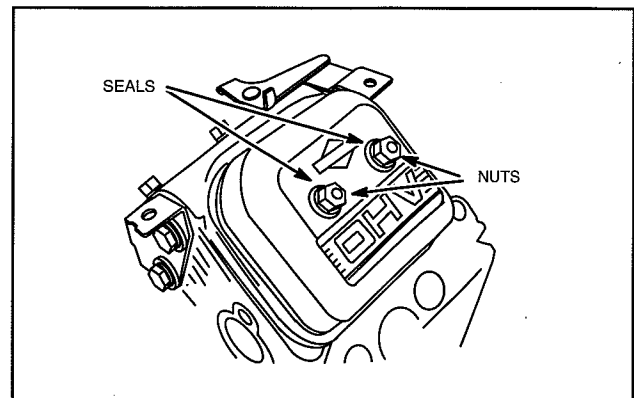

Fig. 33 – Install Push Rods And Valve Covers

OIL COOLER

Some engines are equipped with an oil cooler. The oil cooler is mounted on the blower housing. Filtered oil is routed through the oil cooler through two oil lines from a special oil filter adapter. Forced air from the flywheel fan flows through the oil cooler fins dissipating heat from the engine oil.

The oil cooler fins should be cleaned every 100 hours checked periodically for debris and cleaned with compressed air or a soft bristle brush.

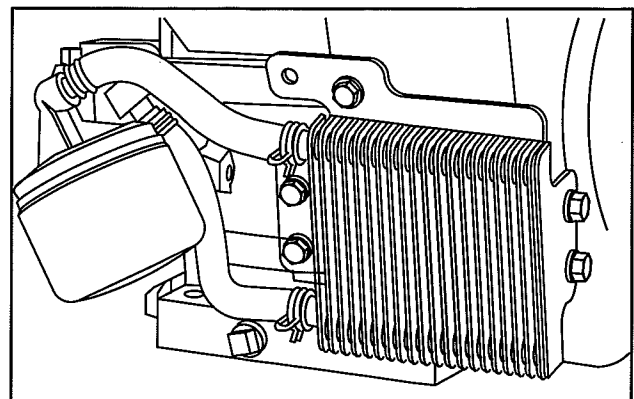
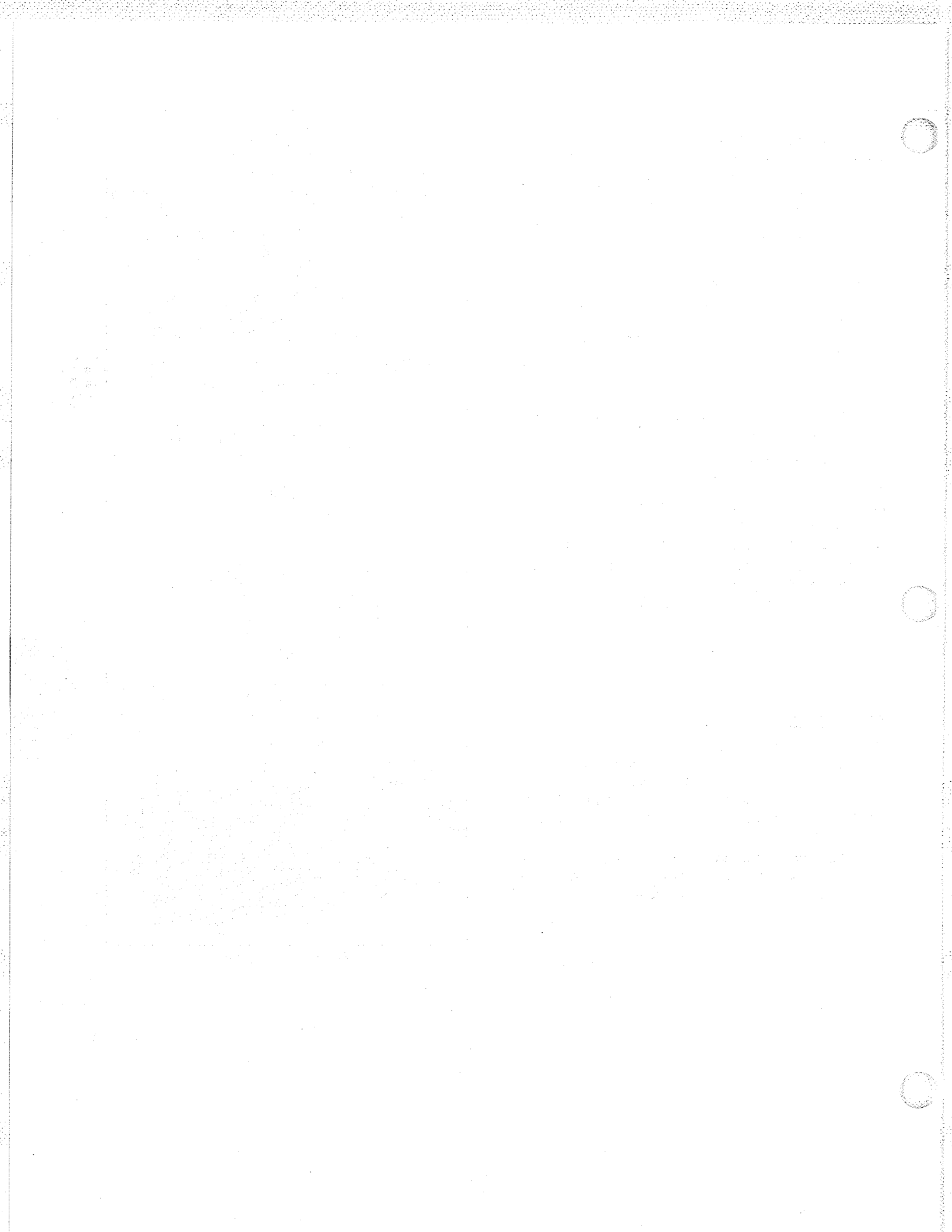
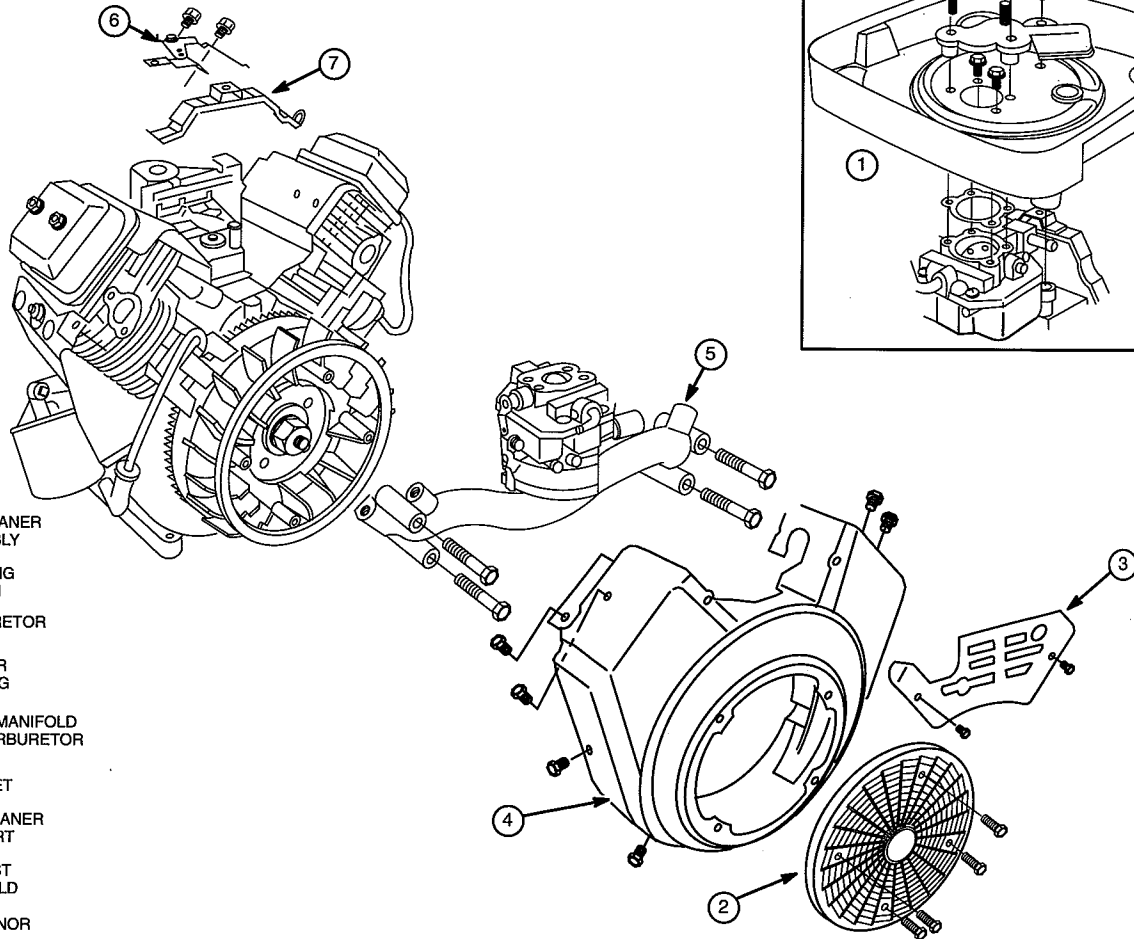
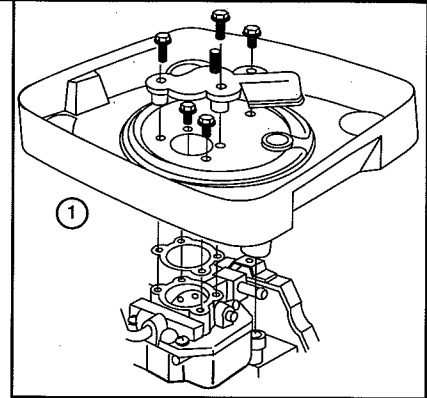

Fig. 34 – Oil Cooler



Section 9

Engine Disassembly



- ① AIR CLEANER ASSEMBLY
- ② ROTATING SCREEN
- ③ CARBURETOR COVER
- ④ BLOWER HOUSING
- ⑤ INTAKE MANIFOLD AND CARBURETOR
- ⑥ CHOKE BRACKET
- ⑦ AIR CLEANER SUPPORT
- ⑧ EXHAUST MANIFOLD
- ⑨ GOVERNOR LEVER
- ⑩ GOVERNOR CONTROL BRACKET
- ⑪ VALLEY COVER
- ⑫ CYLINDER SHIELDS
- ⑬ VALVE COVERS

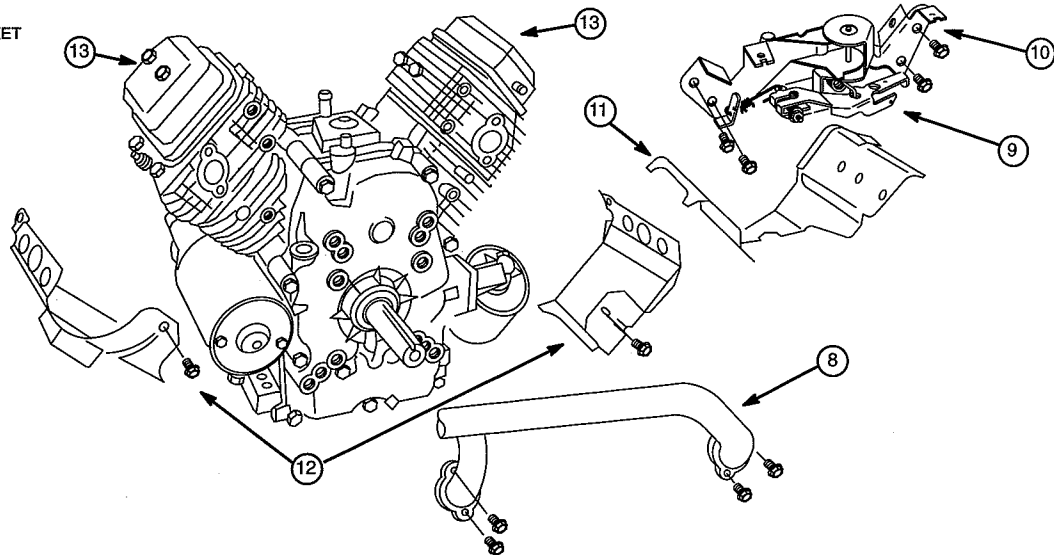

- (14) CYLINDER HEADS
- (15) PUSH RODS
- (16) FLYWHEEL
- (17) ALTERNATOR
- (18) ARMATURES
- (19) BACKPLATE
- (20) STARTER MOTOR
- (21) BREATHER

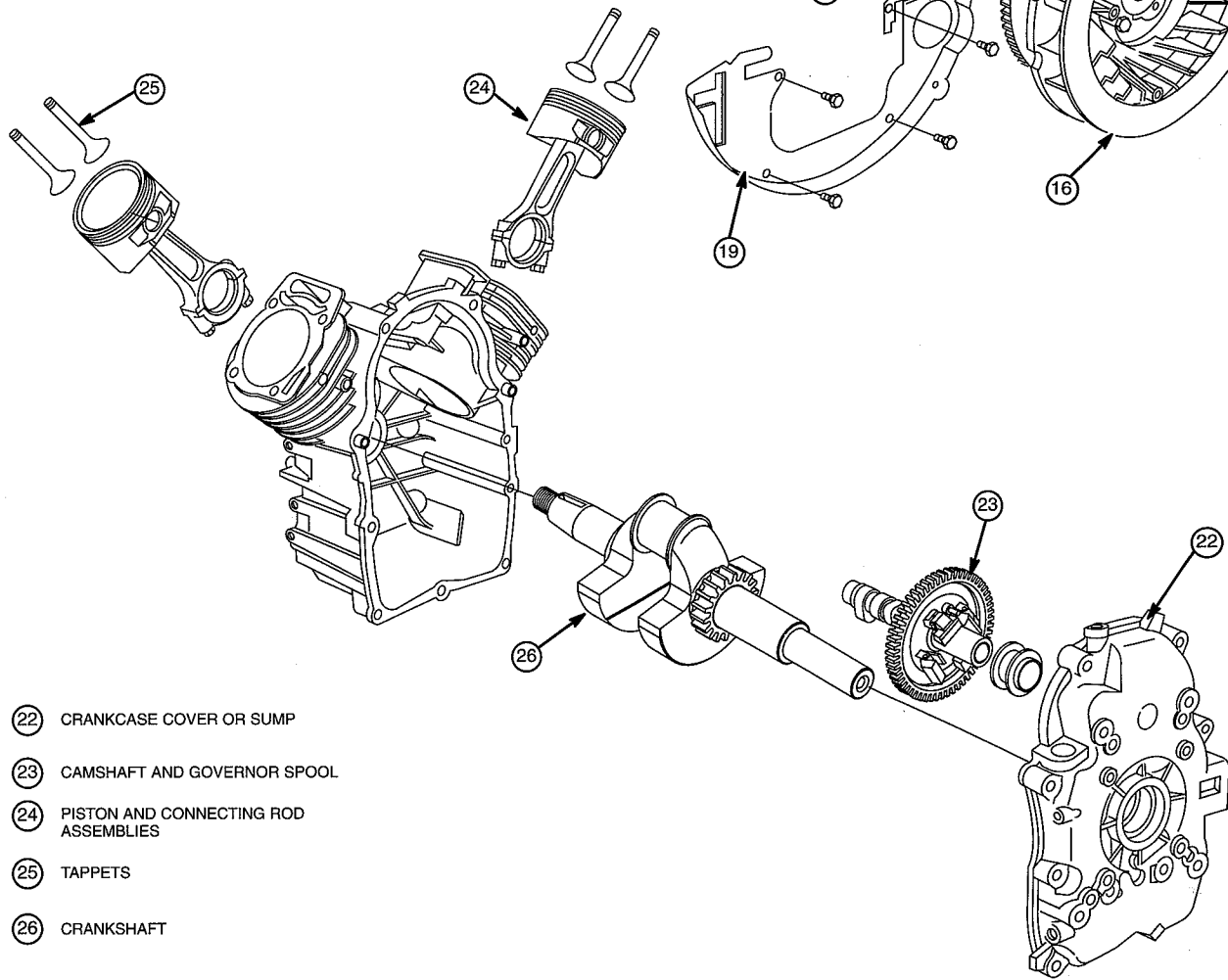

ENGINE DISASSEMBLY

Drain oil, remove oil filter and remove engine from equipment. Remove spark plugs. Remove flywheel, disconnect stop switch wires at armatures and remove armatures. See Section 2. Remove cylinder heads. See Section 5.

1. Remove the following parts, Fig. 1.
 - a. Breather assembly (Models 290000 – 351000)
 - b. Alternator
 - c. Backplate
 - d. Starter motor
2. Remove crankcase cover or sump.
 - a. Remove governor spool from camshaft, Fig. 2.
 - b. Discard gasket and "O"-ring.
3. Rotate crankshaft and camshaft until timing marks align and remove camshaft, Fig. 2.
 - a. Remove tappets.

Note: Remove any carbon or ridge at the top of cylinder bores to prevent breaking rings when removing piston and connecting rod assemblies.

4. Remove No. 2 connecting rod cap and push connecting rod and piston assembly out of cylinder, Fig. 3.
 - a. Reassemble cap to rod to prevent interchanging.
5. Repeat for other cylinder.

6. Remove crankshaft, Fig. 4.

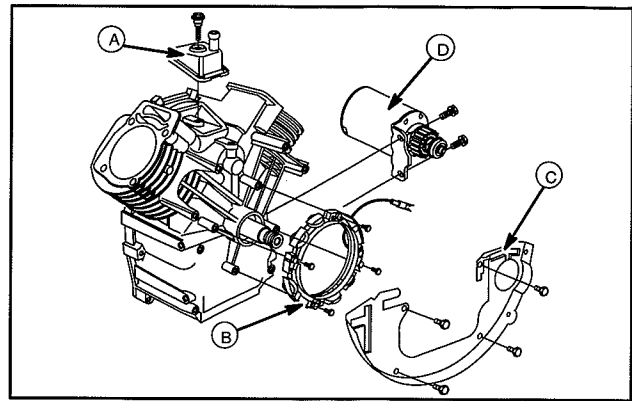

Fig. 1 – Remove Alternator, Backplate, Starter Motor

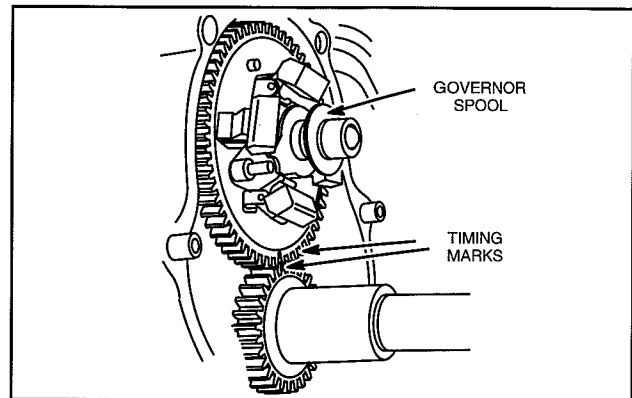

Fig. 2 – Remove Camshaft

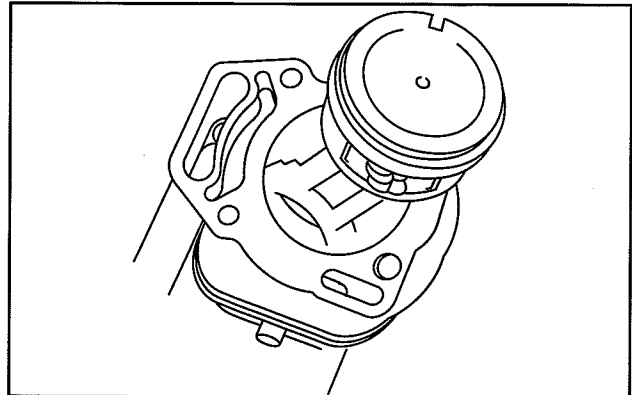

Fig. 3 – Remove Pistons And Connecting Rods

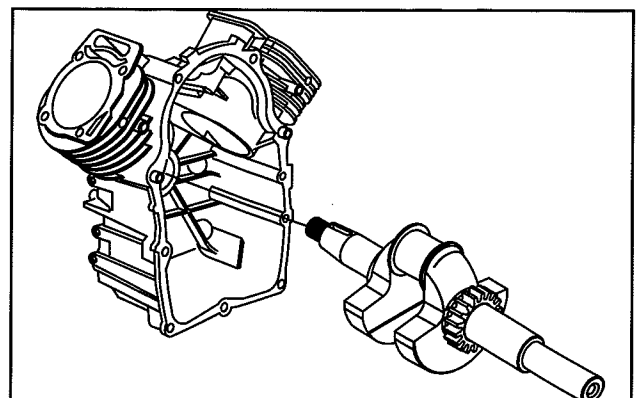

Fig. 4 – Remove Crankshaft

7. Remove oil pump from crankcase cover or sump,
Fig. 5 or Fig. 6.
 - a. Discard "O"-rings.

CLEAN ALL SURFACES OF GASKET MATERIAL.
REMOVE OIL SEALS AND THOROUGHLY CLEAN
COMPONENTS IN SOLVENT. ORGANIZE COM-
PONENTS, KEEPING PARTS WHICH ARE AN
ASSEMBLY TOGETHER.

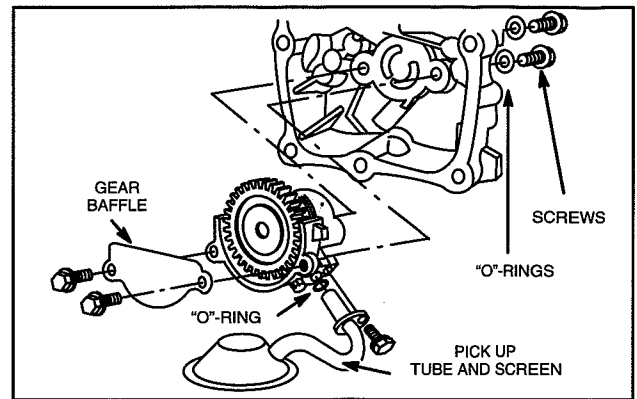

Fig. 5 – Remove Oil Pump – Horizontal Crankshaft

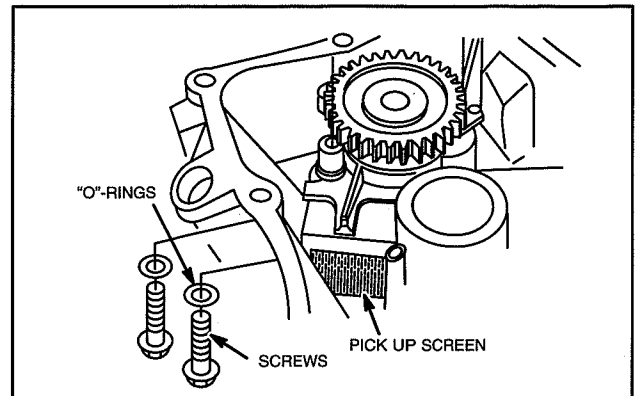

Fig. 6 – Remove Oil Pump – Vertical Crankshaft

Section 10

Cylinder & Crankcase Cover Or Sump Inspection & Repair

Section Contents

| | Page |
|--|------|
| CYLINDER | |
| Checking Cylinder | 1 |
| Resizing | 2 |
| Cylinder Finish | 3 |
| Cleaning | 3 |
| BEARINGS | |
| Check Mag Bearing – Engines Built After 9704300 | 3 |
| Replace Mag Bearing – Engines Built After 9704300 | 4 |
| Remove Mag Bearing | 4 |
| Install Mag Bearing | 4 |
| Check Mag Bearing – Engines Built Before 9705010 | 4 |
| Replace Mag Bearing – Engines Built Before 9705010 | 4 |
| Remove Mag Bearing | 5 |
| Install Mag Bearing | 5 |
| Check PTO Ball Bearing | 6 |
| Replace Ball Bearing | 6 |
| Remove Ball Bearing | 6 |
| Install Ball Bearing | 7 |
| Check PTO Plain Bearing | 7 |
| Check Cam Shaft Bearings | 7 |
| OIL SEALS | 7 |
| HONING FIXTURE | 8 |

10

CHECK CYLINDER

Check cylinder for cracks, stripped threads or broken fins. Check cylinder bores for damage or scoring.

1. Check cylinder head mounting surface for distortion with a straight edge, Fig. 1.

If mounting surfaces are distorted more than .004" (0.1 mm), the cylinder must be replaced.

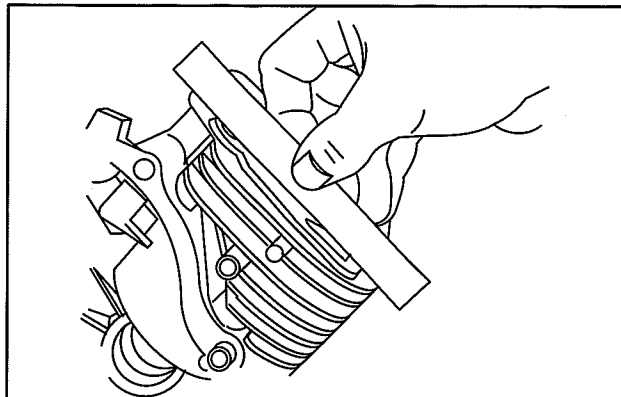

Fig. 1 – Check Cylinder

2. Check cylinder bores for wear using telescoping gauge, Tool #19404 and dial caliper, Tool #19199.
 - a. Measure cylinder bore in 6 points at right angles as shown, Fig. 2.
 - b. If cylinder bore is worn more than .003" (0.075 mm) or more than .0015" (0.035 mm) out of round, it must be resized.

| Engine Model | Standard Bore Size | |
|---------------|----------------------|-----------------------|
| | Min. | Max. |
| 290000-303000 | 68.0 mm (2.677") | 68.025 mm (2.678") |
| 350000-351000 | 72.0 mm (2.835") | 72.025 mm (2.836") |
| 380000 | 75.5 mm (2.9724") | 75.52 mm (2.973") |

Note: If cylinder bores are within specification and show no signs of scoring or other damage, new piston rings may be installed providing the cylinder bores are reconditioned using a rigid hone with finishing stones, to restore the proper cross hatch angle in the cylinder bores. The proper cylinder cross hatch ensures proper lubrication and piston ring break in.

Refer to Page 2, "Cylinder Finish" (Cross Hatch) for correct procedure for installing cross hatch.

Resizing

Always resize to exactly .010" (25 mm) or .020" (.51 mm) or .030" (.76 mm) over standard bore size. If this is done accurately, the service oversize rings and pistons will fit perfectly and proper clearances will be maintained.

Cylinders can be quickly resized with a good hone such as Briggs & Stratton Tool #19205. Contact your Briggs & Stratton source of supply. Use the stones and lubrication recommended by the hone manufacturers to produce the correct cylinder cross hatch.

Note: Automatic transmission fluid is an acceptable honing oil. Another acceptable honing oil can be made by mixing 4 parts No. 30 weight oil with 1 part kerosene.

If a boring bar is used, a hone must be used after the boring operation to produce the proper cylinder cross hatch.

Honing is done with a variable speed 1/2", portable drill and a honing fixture. See page 8 for dimensions to make your own honing fixture.

Use three crankcase cover mounting screws and fasten cylinder to a honing fixture, Fig. 3.

Clamp honing fixture and cylinder securely in a vise at a convenient work height. Place hone drive shaft in chuck of portable drill and tighten.

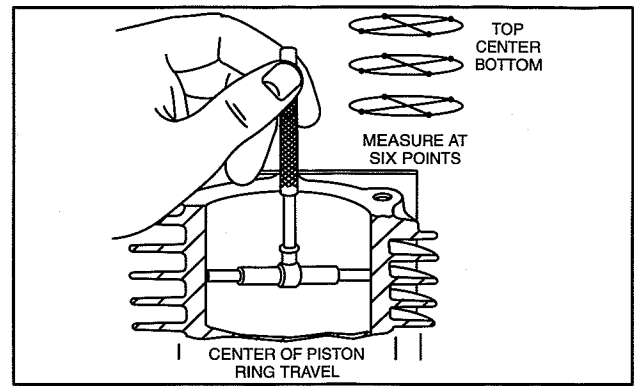

Fig. 2 - Check Cylinder Bore

Cut a wood block and place inside cylinder to prevent hone from extending further than 3/4" to 1" (19 mm to 25 mm) below cylinder bore.

Place hone in middle of cylinder bore. Tighten adjusting knob with finger until stones fit snugly against cylinder wall. **DO NOT FORCE.** Connect drive shaft to hone. Be sure that cylinder and hone are centered and aligned with drive shaft and drill spindle.

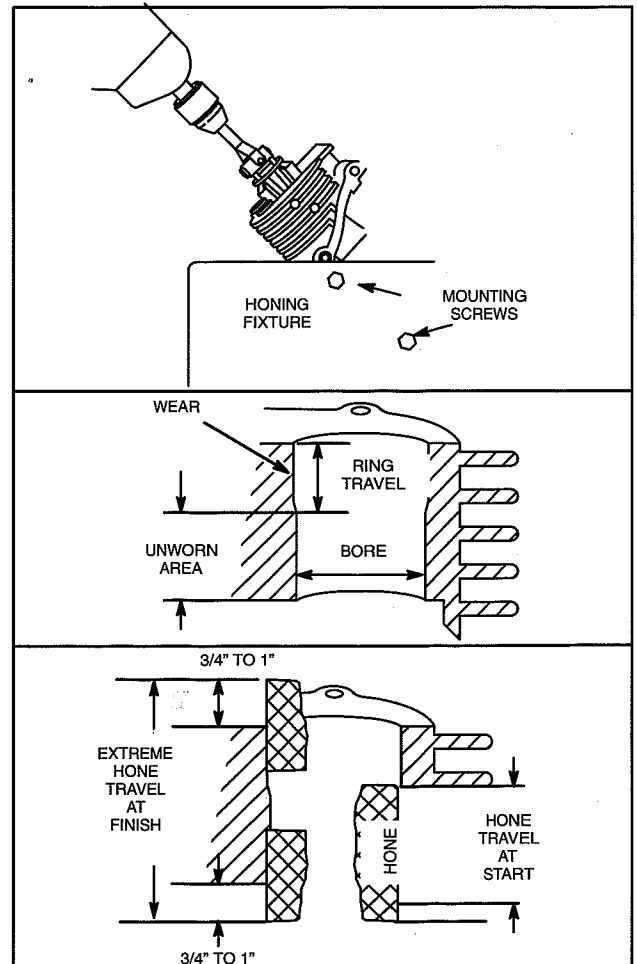

Fig. 3 - Honing Cylinders

Lubricate hone as recommended by hone manufacturer. The recommended drill speed is 300 to 700 RPM MAXIMUM and 40-60 strokes per minute. Because cylinder bores normally wear only in the area of ring travel, the cylinder bore will be round above and below ring travel, Fig. 3. Start drill and, as hone spins, move it up and down at the bottom of the cylinder bore. Gradually increase the length of the strokes until hone travels full length of cylinder bore, and no more than 3/4" to 1" above cylinder bore, Fig. 3. Lubricate hone frequently to prevent build up on stones.

As cutting tension decreases, stop hone and tighten adjusting knob following hone manufacturer's recommendations. Check cylinder bore frequently.

Cylinder Finish (Cross Hatch)

The finishing stones are used after the cylinder bore has been resized to within .0015" (.04 mm) of the desired size or when reconditioning a cylinder bore. The finishing stones will produce the correct cross hatch necessary for proper lubrication. The correct cross hatch angle is approximately 45 degrees, Fig. 4. It is recommended that the cylinder bores be reconditioned to restore the cross hatch when new piston rings are to be installed in a cylinder that is within specification. Be careful not to hone oversize or it will be necessary to resize the cylinder.

Note: To produce the proper cross hatch finish use a drill speed of approximately 200 RPM and 40-60 strokes per minute. Lubricate hone liberally to prevent build up on finishing stones.

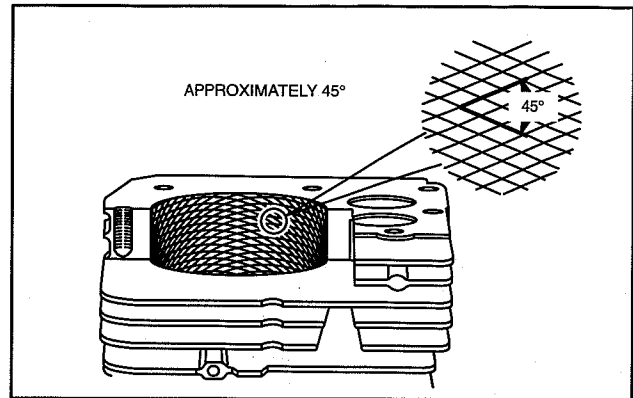

Fig. 4 – Cross Hatch

Cleaning

IT IS MOST IMPORTANT THAT THE ENTIRE CYLINDER AND CRANKCASE BE THOROUGHLY CLEANED AFTER HONING. First wash the cylinder and crankcase carefully in a solvent such as kerosene or commercial solvent. Then thoroughly wash cylinder and crankcase using a stiff brush with soap and hot water. Rinse thoroughly with hot running water. Repeat washing and rinsing until all traces of honing grit are gone.

Honing grit is highly abrasive and will cause rapid wear to all of the internal components of the engine unless it is completely removed.

Note: When cylinder and crankcase have been thoroughly cleaned, use a clean white rag or napkin and wipe the cylinder bore. If honing grit is present it will appear as a gray residue on rag. If any honing grit is evident, re-wash and rinse entire cylinder and crankcase and check again. When there is no trace of honing grit on rag, the cylinder is properly cleaned. Then oil cylinder bore to prevent rusting.

BEARINGS

Check Mag Bearing – Engines Built After 9704300

Check magneto bearing for damage. Check for wear using plug gauge, Tool #19219, Fig. 5. Try gauge at several locations.

If plug gauge is not available, see reject dimension below.

Reject Dimension: 35.12 mm (1.383")

Replace bearing if damaged or worn.

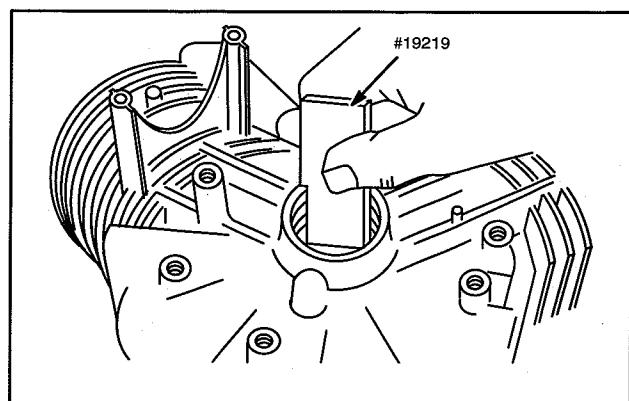

Fig. 5 – Check Mag Bearing

Replace Mag Bearing – Engines Built After 9704300

Insert bushing driver, Tool #19450 into bearing from oil seal side. Place a reference mark on driver to indicate proper depth of bushing when installing new bearing, Fig. 6.

Remove Mag Bearing

1. Place cylinder on cylinder support, Tool #19227 with large opening facing bearing.
2. Press out bearing with bushing driver, Tool #19450.

Install Mag Bearing

1. Place cylinder on cylinder support, Tool #19227 with large opening facing bearing, Fig. 7.
2. Align oil holes in bearing with oil holes in cylinder.
3. Press in new bearing to correct depth with bushing driver, Tool #19450.

4. Stake bearing in top notch with 1/8" round pin punch to prevent bearing from turning, Fig. 8.
 - a. Install new oil seal with sealing lips facing in.
 - b. Use cylinder support, Tool #19227 and press oil seal until flush with cylinder.

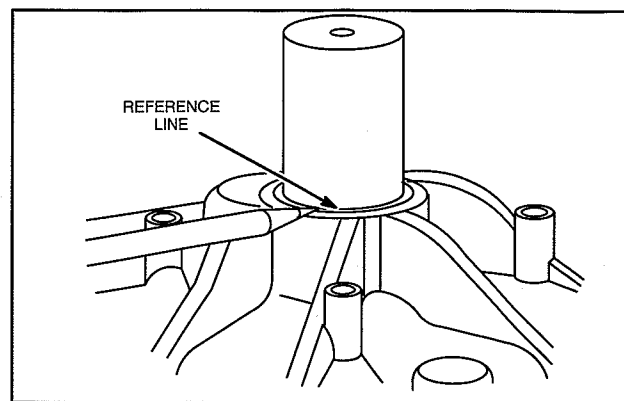

Fig. 6 – Reference Line

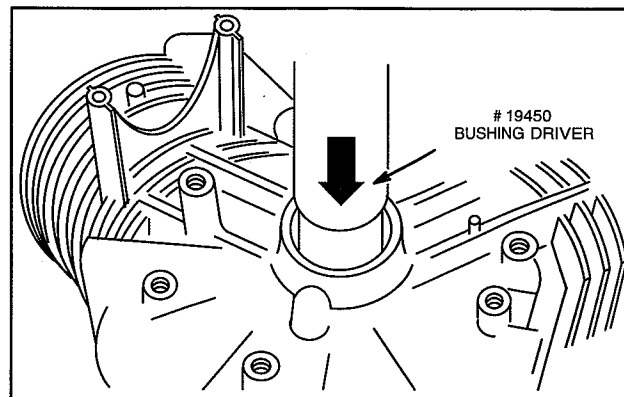

Fig. 7 – Removing/Installing Bearing

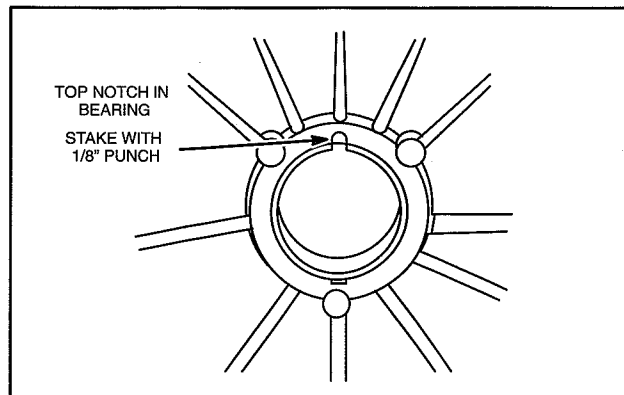

Fig. 8 – Stake Bearing

Check Mag Bearing – Engines Built Before 9705010

Check magneto bearing for damage. Check for wear using plug gauge, Tool #19380, Fig. 5. Try gauge at several locations.

If plug gauge is not available, see reject dimension below.

Reject Dimension: 30.08 mm (1.1845")

Replace bearing if damaged or worn.

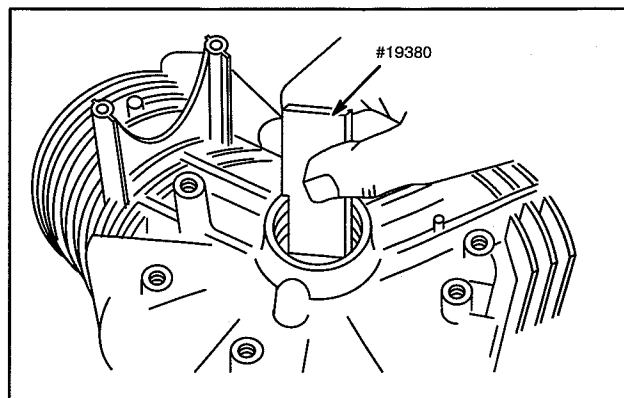

Fig. 9 – Check Mag Bearing

Replace Mag Bearing – Engines Built Before 9705010

Insert bushing driver, Tool #19349 into bearing from oil seal side. Place a reference mark on driver to indicate proper depth of bushing when installing new bearing.

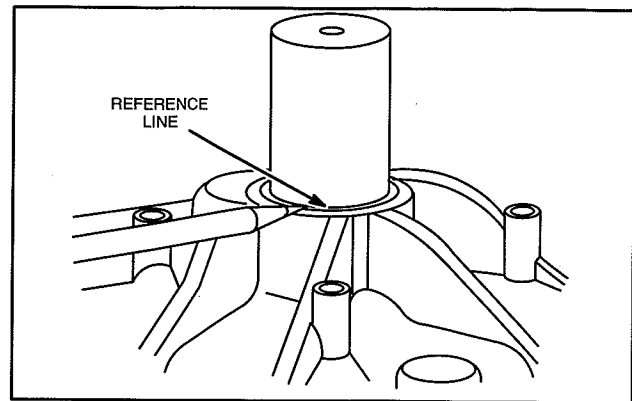

Fig. 10 – Reference Line

Remove Mag Bearing

The magneto bearing has a roll pin installed in the oil gallery to prevent the bearing from turning.

1. Drive roll pin into oil gallery using a 4.8 mm (3/16") punch.
2. Place cylinder on cylinder support, Tool #19227 with large opening facing bearing.
3. Press out bearing with bushing driver, Tool #19349.

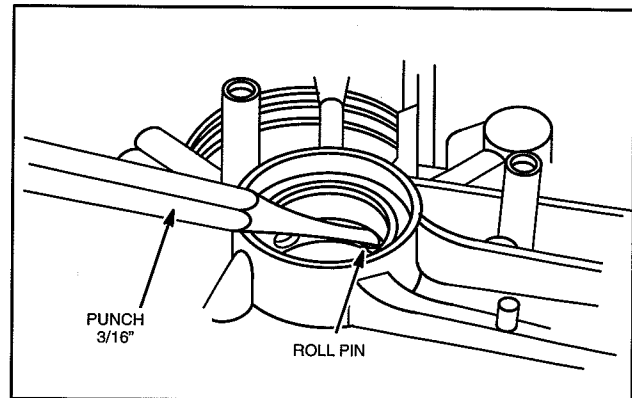

Fig. 11 – Drive Locating Pin

Install Mag Bearing

1. Place cylinder on cylinder support, Tool #19227 with large opening facing bearing, Fig. 12.
2. Align oil holes in bearing with oil holes in cylinder.
3. Press in new bearing to correct depth with bushing driver, Tool #19349.

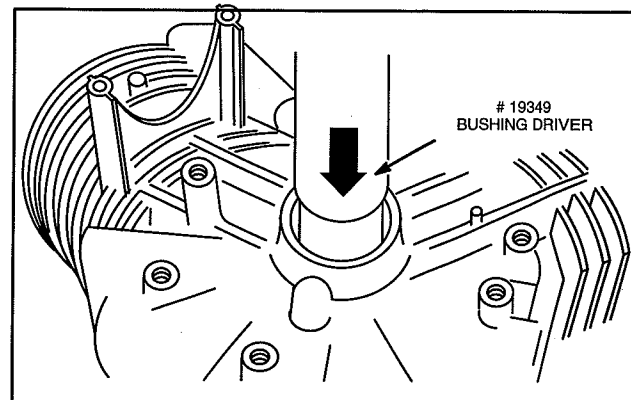

Fig. 12 – Install Mag Bearing

4. Grind off the taper, approximately 3 mm (1/8"), from one end of new roll pin as shown, Fig. 8.
 - a. Quench pin in water periodically to prevent loss of temper.
 - b. Remove all burrs and clean thoroughly.

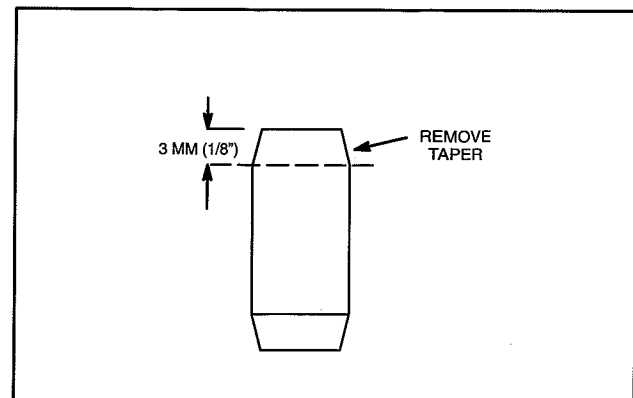

Fig. 13 – Grinding Roll Pin

5. Place tapered end of new roll pin in oil hole in bearing.
6. Use Tool #19344, Roll Pin Driver, to install new roll pin, Fig. 14.
 - a. Drive in new roll pin until tool bottoms.
 - b. Use cylinder support, Tool #19227 and press oil seal until flush with cylinder.

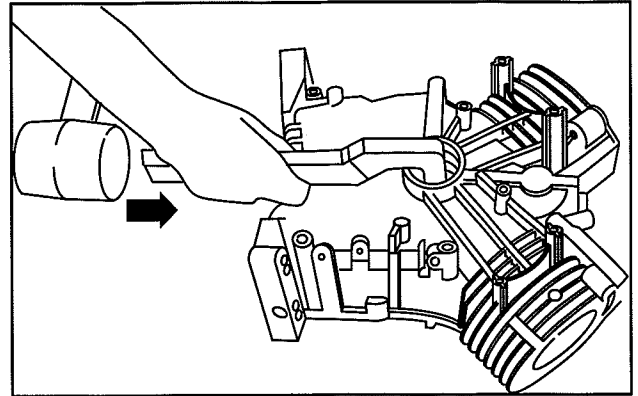

Fig. 14 – Installing Roll Pin

Check PTO Ball Bearing

Ball bearings must rotate freely. If any rough spots are felt the ball bearing must be replaced.

DO NOT re-use ball bearings that have been pressed or pulled from crankcase cover. The bearing races are usually damaged during removal.

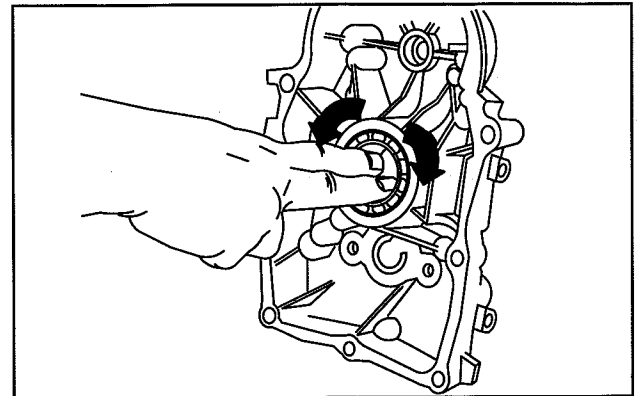

Fig. 15 – Check Ball Bearing

Replace Ball Bearing

The following tools are recommended when replacing the ball bearing.

| Tool Description | Tool No. |
|------------------|----------|
| Washer | 224061 |
| Puller Screw | 19318 |
| Driver | 19401 |
| Pilot | 19396 |
| Support | 19440 |

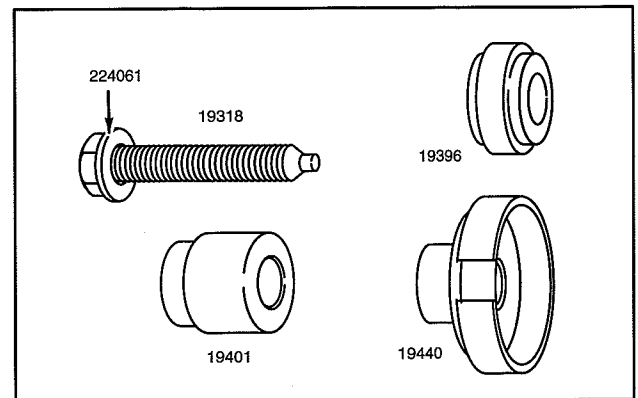

Fig. 16 – Ball Bearing Replacement Tools

Remove Ball Bearing

1. Assemble washer #224061, to puller screw #19318, and insert through large end of driver #19401.
2. Place open side of support #19440, over ball bearing.
3. Insert screw with driver through ball bearing and thread into support.
 - a. Continue tightening screw until ball bearing is removed, Fig. 17.

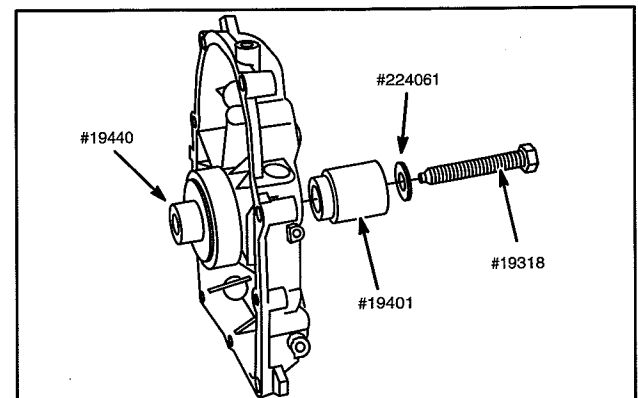

Fig. 17 – Remove Ball Bearing

Install Ball Bearing

Lubricate outside diameter of ball bearing before installing.

1. Place ball bearing on to support #19440.
2. Insert large end of pilot #19396 into oil seal boss in cylinder.
3. Insert screw and washer through pilot and thread into support.
 - a. Tighten screw until bearing is seated.
 - b. Use cylinder support, Tool #19227 and press oil seal until flush with crankcase cover 9.

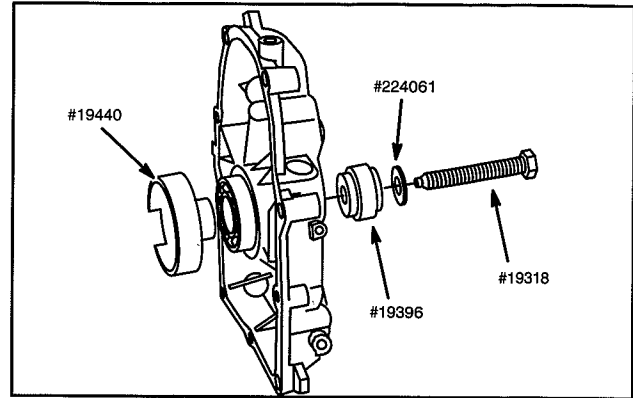

Fig. 18 – Install Ball Bearing

Check PTO Plain Bearing

The sump must be replaced if PTO bearing is scored or if Plug Gauge, Tool #19380, enters bearing. Try gauge at several locations in bearing, Fig. 19.

If plug gauge is not available, see reject dimension below.

Reject Dimension: 35.07 mm (1.381")

Install Oil Seal

When installing new PTO oil seal, use 47.6 mm (1-7/8") side of Cylinder Support, Tool #19227. Press in seal until it is 1.5 mm (1/16") below mounting surface.

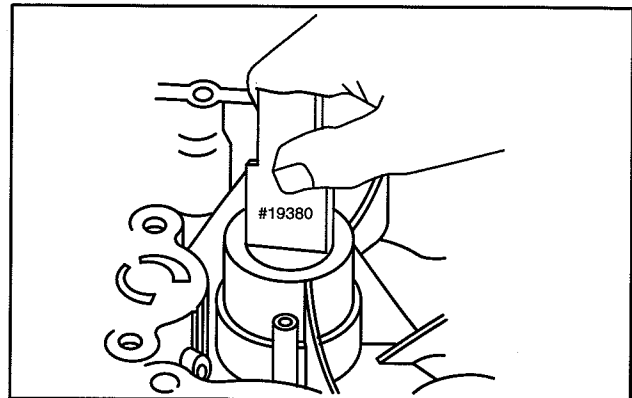

Fig. 19 – Check PTO Bearing

CHECK CAM SHAFT BEARINGS

Use Plug Gauge, Tool #19384, to check cam bearing, magneto side. Use Plug Gauge, Tool #19386, to check cam bearing, PTO side. Plug gauge should not enter bearing. If plug gauges are not available, see reject sizes below. If cam bearings are worn, cylinder or crankcase cover must be replaced.

| Cam Bearing Reject Size | | |
|-------------------------|---------------------|---------------------|
| All Models | Magneto Bearing | PTO Bearing |
| | 16.08 mm (.633") | 20.04 mm (.789") |

OIL SEALS

Always install new oil seals whenever engine is disassembled for major servicing or when repairing bearings. Lubricate sealing edge of oil seal with clean engine oil before assembly. Always use the correct seal protector to prevent damaging oil seal.

HONING FIXTURE

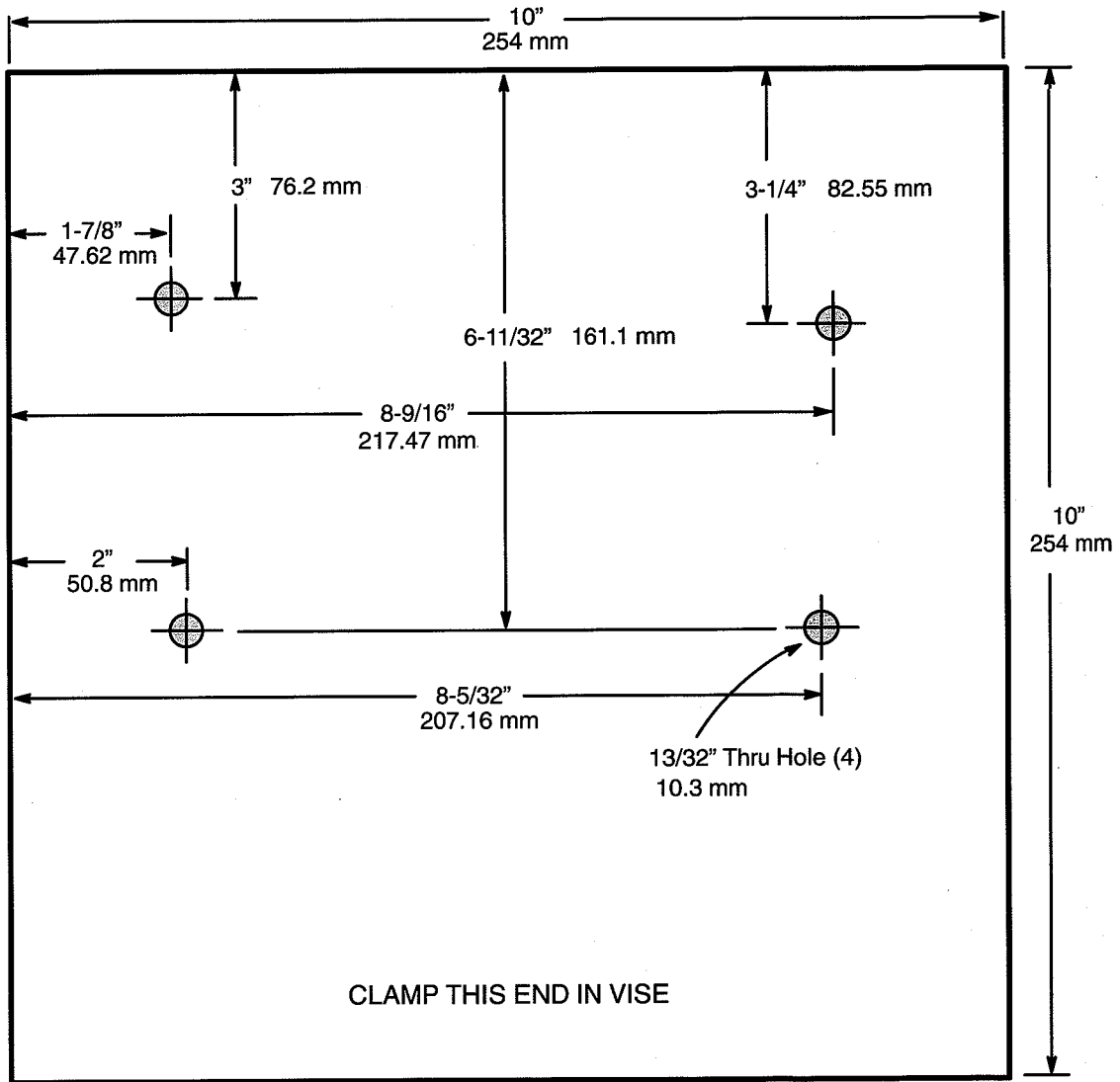

Material – Wood 2" x 10" x 10" long
(50.8 mm x 254 mm x 254 mm long)

Cylinder Mounting Hardware

Fasteners Required: 4 Crankcase Cover Screws
4 Flat Washers 3/8" (9.5 mm) I.D.

Section 11

Crankshaft And Camshaft

Section Contents

| | Page |
|---------------------------|------|
| CHECKING CRANKSHAFT | 1 |
| CHECKING CAMSHAFT | 2 |

CHECKING CRANKSHAFT

Engines manufactured after 97043000 have larger diameter Mag. journal. Cylinders and crankshafts may be used on earlier engines only as an assembly.

Inspect crankshaft threads and keyways for damage or wear. If threads or keyways are damaged or worn, replace crankshaft. Check journals for scoring. If journals are scored, replace crankshaft. Check journals for wear. See crankshaft reject sizes.

| Crankshaft Reject Sizes | | | |
|---------------------------|----------------------|----------------------|------------------------|
| After 97043000 | PTO Journal | Mag. Journal | Crankshaft Crankpin |
| | 34.92 mm (1.375") | 34.95 mm (1.376") | 36.95 mm (1.455") |

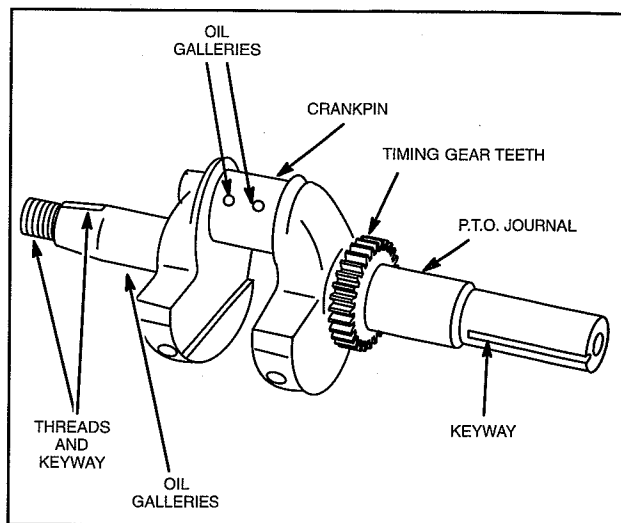

Fig. 1 – Check Crankshaft

| Crankshaft Reject Sizes | | | |
|----------------------------|----------------------|----------------------|------------------------|
| Before 97050100 | PTO Journal | Mag. Journal | Crankshaft Crankpin |
| | 34.92 mm (1.375") | 29.94 mm (1.179") | 36.95 mm (1.455") |

Check oil galleries for blockage or obstructions. Check timing gear for damaged teeth. Timing gear is replaceable. See illustrated parts list.

Crankshaft crankpin may re-ground for .020" under-size connecting rods. See illustrated parts list for part number. See crankshaft grinding dimensions.

Crankshaft Grinding Dimensions, Fig. 2

| Dim. A | Dim. R | Dim. T |
|--|-------------------------------------|---|
| 1.4782 / 1.479" (37.54 / 37.56 mm) | .170 / .180" (4.32 / 4.57 mm) | 1.4435 / 1.4465" (36.66 / 36.74 mm) |

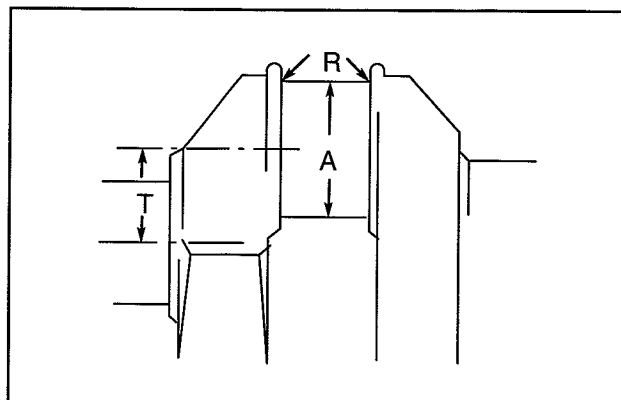

Fig. 2 – Crankshaft Grinding Dimensions

CHECK CAMSHAFT

Inspect gear teeth, lobes and journals for wear and nicks, Fig. 3. Camshaft journal and lobe reject sizes are shown below.

Governor slider must move freely on PTO journal of cam shaft. Flyweight must pivot freely. Make sure flyweight spring is not stretched. Governor weights must move freely on hinge pins. Make sure hinge pins are not loose.

| Camshaft Reject Sizes | | | |
|------------------------|----------------------|----------------------|----------------------|
| Models 290000 – 351000 | | | |
| PTO Journal | Mag. Journal | Int. Lobes | Ex. Lobes |
| 19.92 mm (.7845") | 15.93 mm (.6273") | 30.25 mm (1.191") | 30.25 mm (1.191") |

| Camshaft Reject Sizes | | | |
|-----------------------|----------------------|----------------------|----------------------|
| Models 380000 | | | |
| PTO Journal | Mag. Journal | Int. Lobes | Ex. Lobes |
| 19.92 mm (.7845") | 15.93 mm (.6273") | 31.01 mm (1.221") | 30.25 mm (1.191") |

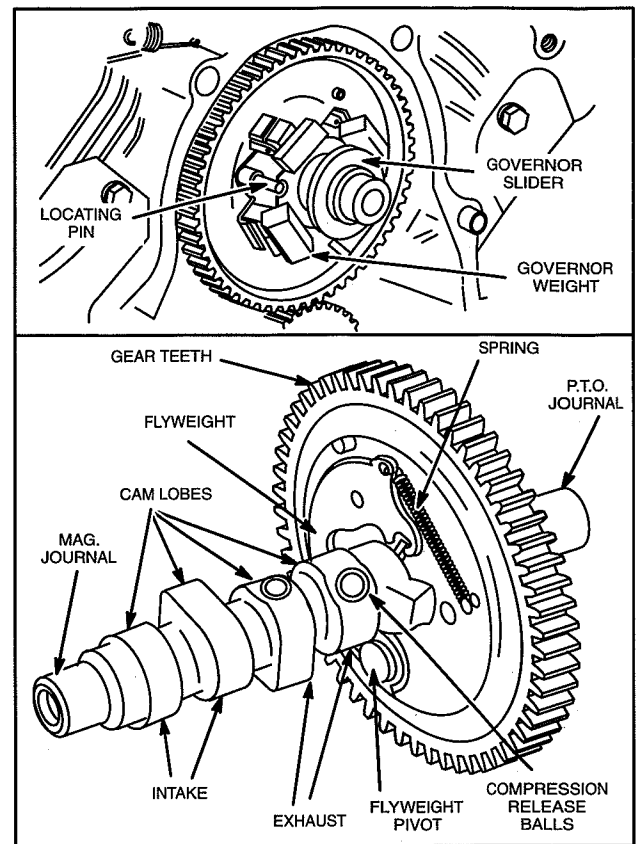

Fig. 3 – Check Camshaft

Section 12

Piston, Rings And Connecting Rod Inspection And Assembly

Section Contents

| | Page |
|--|------|
| GENERAL INFORMATION | 1 |
| DISASSEMBLE PISTON AND CONNECTING ROD | 1 |
| CHECKING PISTON AND RINGS | 2 |
| CHECKING PISTON PIN AND CONNECTING ROD | 2 |
| ASSEMBLE PISTON AND CONNECTING ROD | 3 |
| ASSEMBLE PISTON RINGS TO PISTON | 3 |

GENERAL INFORMATION

It is recommended that new piston rings be installed whenever the engine is disassembled for major servicing or overhaul, providing that cylinder bores are within specification.

Remove any carbon or ridge at the top of the cylinder bore. This will prevent breaking the rings when removing the piston and connecting rod from the engine. Remove the connecting rod cap. Push the piston and connecting rod out through the top of the cylinder.

Measure cylinder bores before checking pistons and rings. See Section 10. If cylinder bore(s) require re-sizing it will not be necessary to check pistons and rings since a new oversized piston assembly will be used.

If the cylinder bore is more than .08 mm (.003") oversize, or .04 mm (.0015") out of round, it must be resized.

DISASSEMBLE PISTON AND CONNECTING ROD

1. Remove piston rings using ring expander, Tool #19340, Fig. 1.
 - a. Then remove coil expander.

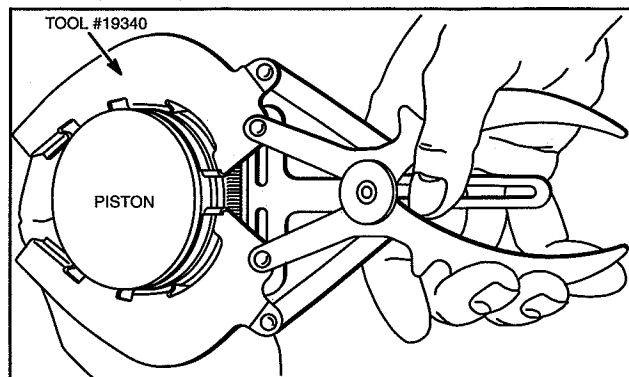

Fig. 1 – Remove Rings

2. Disassemble piston from connecting rod, Fig. 2.
 - a. Remove piston pin locks.
 - b. Piston pin is a slip fit in piston and connecting rod.

Keep pistons and connecting rods together as an assembly. Do not mix.

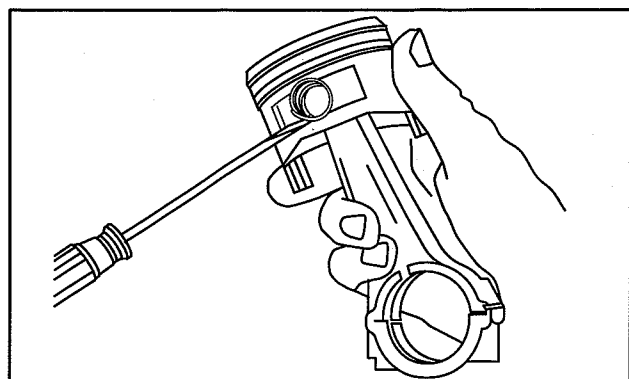

Fig. 2 – Remove Piston Pin Locks

CHECKING PISTON AND RINGS

If the cylinder is not going to be resized and the piston shows no signs of scoring, the piston should be checked. Carefully remove carbon from ring grooves.

1. Check side clearance of ring grooves using NEW rings, Fig. 3. If a 0.10 mm (.004") feeler gauge for the compression rings or .20 mm (.008") for the oil ring can be inserted, the ring groove is worn. The piston must be replaced.

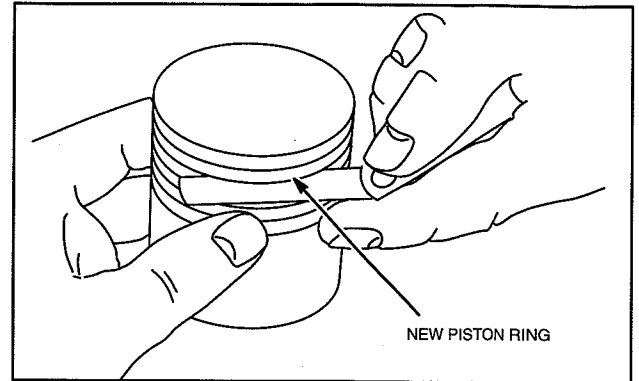

Fig. 3 – Check Ring Grooves

2. Check ring end gap, Fig. 4.
 - a. Clean carbon from end of rings and insert approximately 25 mm (1") into cylinder.

Reject Dimension (all): .030" (0.76 mm)

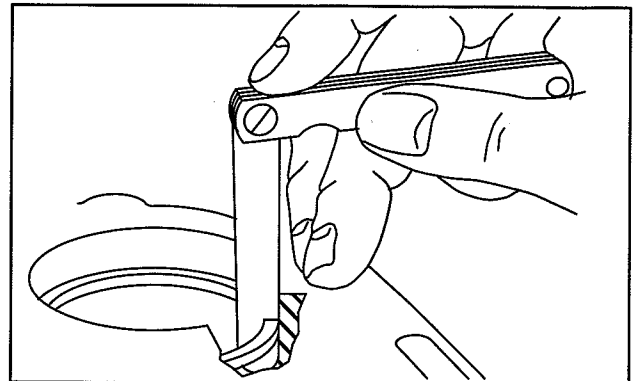

Fig. 4 – Checking Ring End Gap

3. Check piston bore, Fig. 5.
 - a. Replace piston if worn or .01 mm (.0005") out of round.

| Engine Model | Reject Dimension |
|-----------------|------------------|
| 290000 – 351000 | 17.12 mm (.674") |
| 380000 | 18.06 mm (.711") |

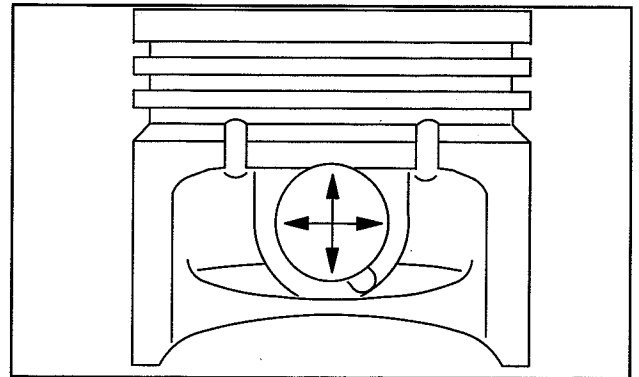

Fig. 5 – Checking Ring End Gap

CHECKING PISTON PIN AND CONNECTING ROD

1. Check piston pin, Fig. 6.
 - a. Replace piston pin if worn or .01 mm (.0005") out of round.

| Engine Model | Reject Dimension |
|-----------------|-------------------|
| 290000 – 351000 | 17.06 mm (.6718") |
| 380000 | 17.98 mm (.7078") |

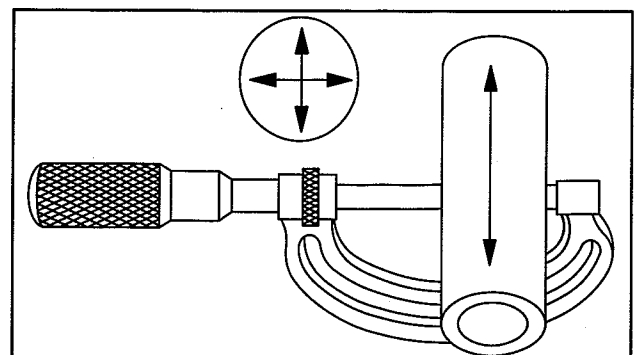

Fig. 6 – Check Piston Pin

2. Check connecting rod bearings, Fig. 7. See reject sizes below.

If crankpin bearing is scored or worn the connecting rod must be replaced.

| Engine Models 290000 – 351000 | |
|-------------------------------|--------------------|
| Crankpin Bearing | Piston Pin Bearing |
| 37.12 mm (1.4615") | 17.12 mm (.674") |

| Engine Models 380000 | |
|----------------------|--------------------|
| Crankpin Bearing | Piston Pin Bearing |
| 37.12 mm (1.4615") | 18.06 mm (.711") |

Note: .020" undersize connecting rods are available for use on a reground crankpin journal. See illustrated parts list.

ASSEMBLE PISTON AND CONNECTING ROD

Lubricate parts with engine oil and assemble #1 piston and connecting rod, Fig. 8.

1. Notch or offset casting mark on piston must face flywheel side.
2. "OUT 1" on connecting rod must face PTO side (opposite notch or casting mark on piston).
 - a. Install piston pin locks with needle nose pliers.

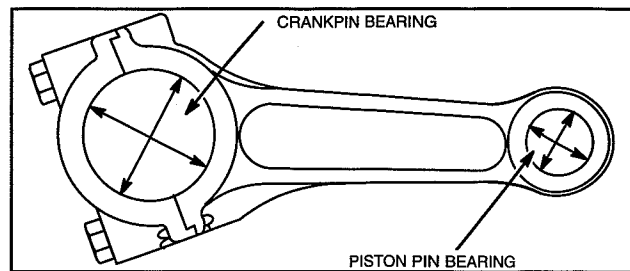

Fig. 7 – Check Rod Bearings

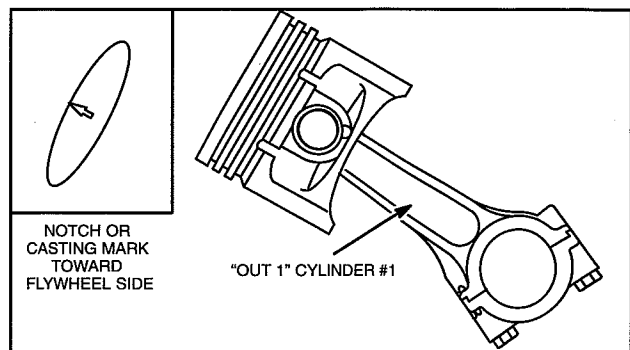

Fig. 8 – Assemble #1 Rod And Piston

Lubricate parts with engine oil and assemble #2 piston and connecting rod, Fig. 8.

1. Notch or offset casting mark on piston must face flywheel side.
2. "OUT 2" on connecting rod must face PTO side (opposite notch or casting mark on piston).
 - a. Install piston pin locks with needle nose pliers.

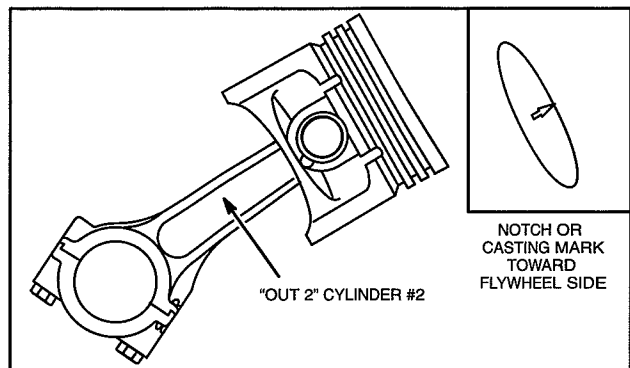

Fig. 9 – Assemble #1 Rod And Piston

ASSEMBLE PISTON RINGS TO PISTON

Install rings in order shown. Use ring expander, Tool #19340 when installing center and top compression rings.

1. Install oil ring expander.
 - a. Install lower scraper ring.
 - b. Install upper scraper ring.
2. Install center compression ring with I.D. mark up.
3. Install top compression ring with I.D. mark up.

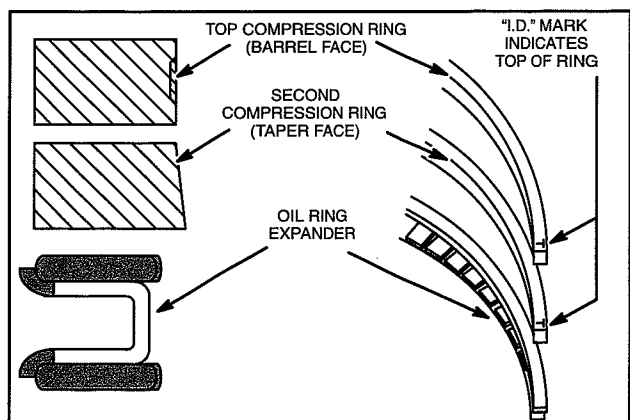
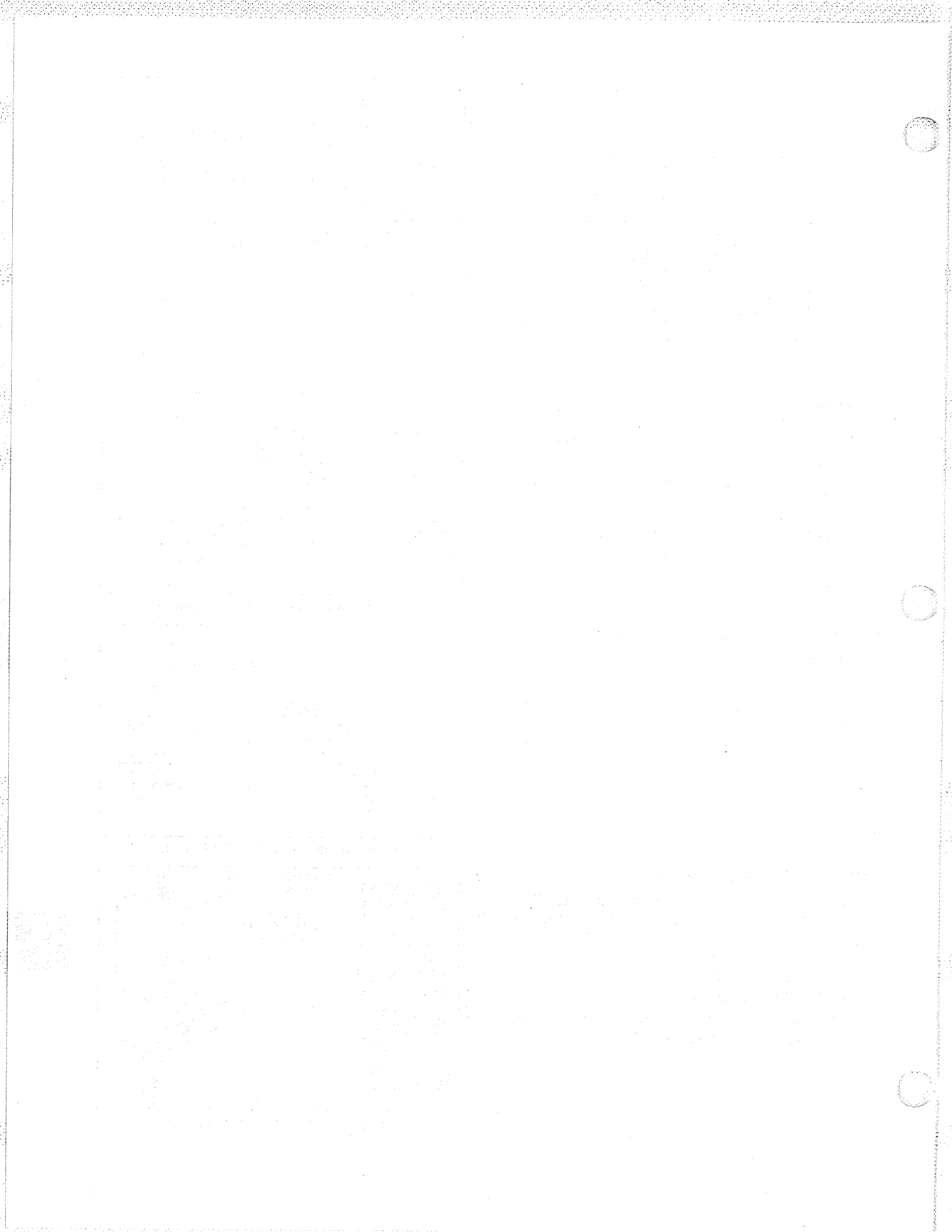

Fig. 10 – Piston Ring Installation



Section 13

Engine Assembly

| Section Contents | Page |
|---|------|
| INSTALL CRANKSHAFT | 1 |
| INSTALL PISTON AND CONNECTING ROD | 2 |
| INSTALL CAMSHAFT | 2 |
| INSTALL CRANKCASE COVER OR SUMP | 3 |
| GENERAL ASSEMBLY | 3 |
| INSTALL FLYWHEEL | 4 |
| Torque Flywheel Nut – Engine Models 290000 – 303000 | 4 |
| Torque Flywheel Nut – Engine Models 350000 – 380000 | 4 |
| Adjust Armature Air Gap | 4 |
| INSTALL CYLINDER HEADS | 4 |
| Install Rocker Arms – Current Style | 5 |
| Install Rocker Arms – Early Style | 5 |
| Install Push Rods | 5 |
| Adjust Valve Clearance | 5 |
| GENERAL ASSEMBLY | 6 |
| ADJUST GOVERNOR | 7 |

INSTALL CRANKSHAFT

Lubricate mag bearing and lips of oil seal with engine oil and install crankshaft.

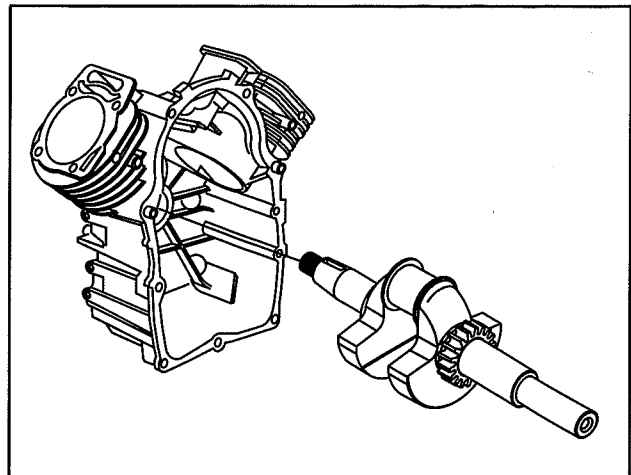

Fig. 1 – Install Crankshaft

INSTALL PISTON AND CONNECTING ROD

Note: Install #1 piston and connecting rod first.

1. Oil piston rings, piston skirt, and compress rings with Ring Compressor Tool #19070, Fig. 2.
 - a. Place piston and ring compressor upside down on bench with projections on compressor facing up.
 - b. Tighten ring compressor evenly until rings are fully compressed.
 - c. Then loosen ring compressor very slightly so that compressor can be rotated on piston skirt while holding connecting rod, Fig. 2.

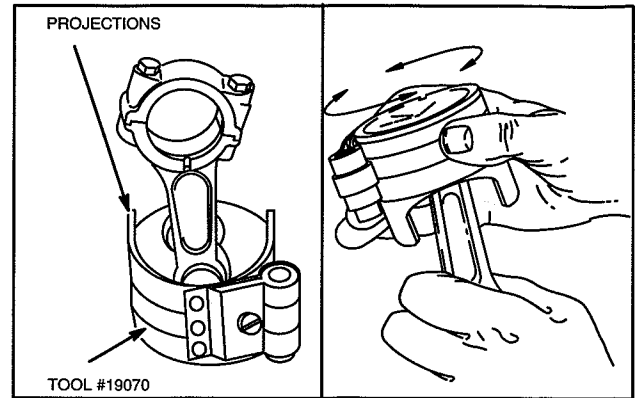

Fig. 2 – Compressing Rings

2. Lubricate cylinder bores and crankpin and rotate crankshaft until it is at bottom of stroke.
3. Install #1 piston with notch or offset casting mark on piston toward flywheel side, Fig. 3.
 - a. Push piston down by hand until connecting rod is seated on crankpin.

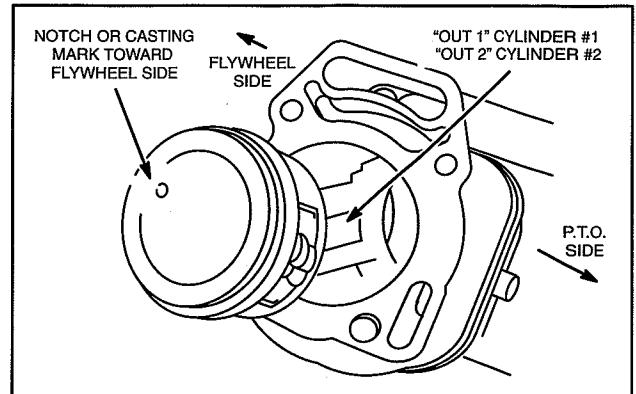

Fig. 3 – Installing Piston And Connecting Rod

4. Assemble connecting rod cap to rod with match marks aligned, Fig. 4.
 - a. Torque screws to 13.0 Nm (115 in. lbs.).
5. Rotate crankshaft two revolutions to check for binding. Rod should also be free to move sideways on crankpin.

Repeat for #2 cylinder.

Note: The words “OUT-1” on #1 connecting rod and “OUT-2” on #2 connecting rod must be facing PTO side.

Important: Failure to use a torque wrench can result in loose connecting rod screws causing breakage or tight connecting rod screws causing scoring.

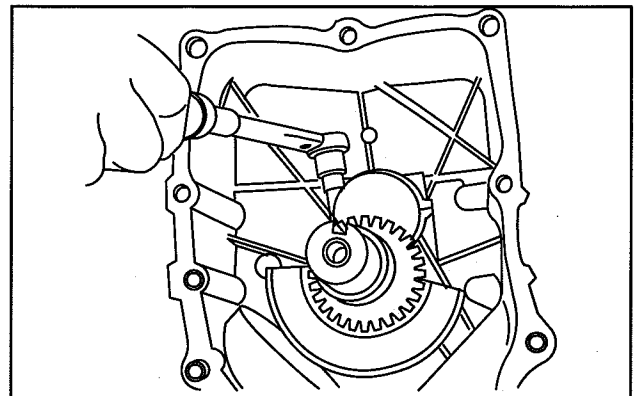

Fig. 4 – Torque Connecting Rods

INSTALL CAMSHAFT

Lubricate tappets, camshaft journals and lobes with engine oil. Assemble timing gear to crankshaft.

1. Install tappets.
2. Align timing marks on camshaft and crankshaft timing gear and install camshaft, Fig. 5.
3. Assemble governor spool to camshaft,
 - a. Make sure that spool engages flyweights and slot on spool fits over locating pin.
 - b. Install new “O”-ring in cylinder.

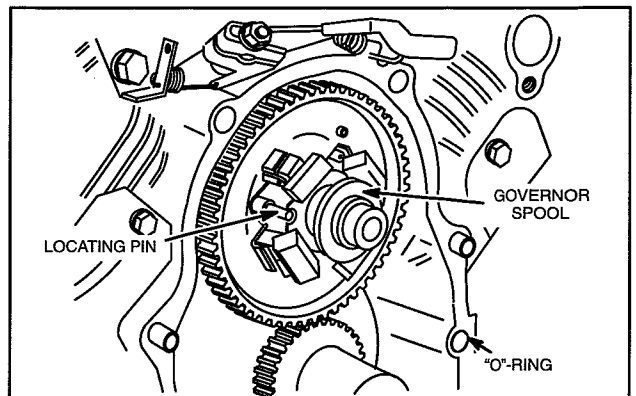

Fig. 5 – Installing Camshaft

INSTALL CRANKCASE COVER OR SUMP

Lubricate PTO and camshaft bearing.

1. Rotate governor shaft so that paddle rests against camshaft bearing support, Fig. 6.
2. Insert proper seal protector through oil seal.

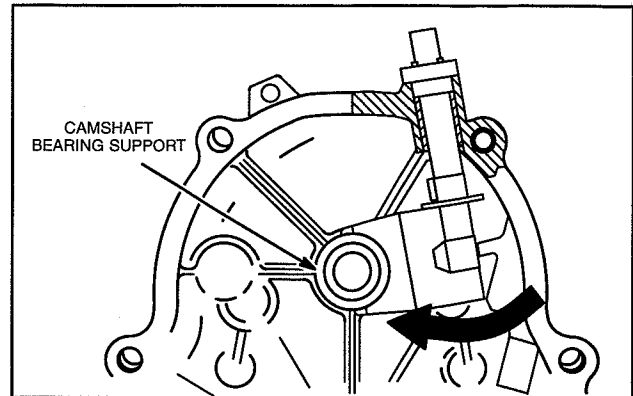

Fig. 6 – Rotate Governor Shaft

3. Install crankcase cover or sump with new gasket, Fig. 7.
4. Torque screws in sequence shown to 17.0 Nm (150 in. lbs.).
5. Check crankshaft end play.

Specification: 0.08 – 0.40 mm (.003" – .015")

Crankshaft end play may be adjusted by adding or removing a thrust washer. Thrust washer kit. Part #807625 contains three shims with the following thickness; 1.0 mm (.039"), 1.25 mm (.049") and 1.5 mm (.059"). The thrust washer is installed on the PTO side of the crankshaft next to timing gear.

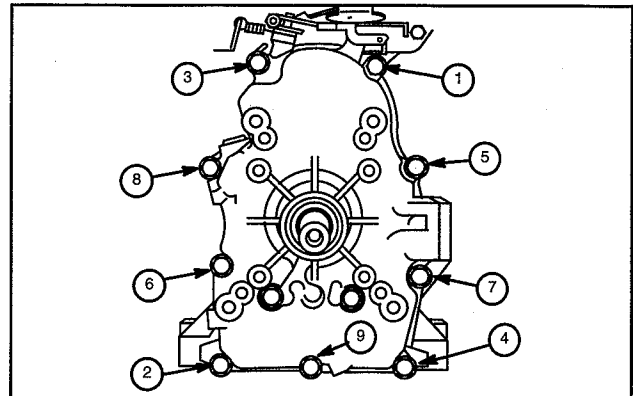

Fig. 7 – Install Crankcase Cover Or Sump

GENERAL ASSEMBLY

1. Install back plate.
 - a. Torque screws to 7.0 Nm (65 in. lbs.).
2. Install alternator, Fig. 8.
 - a. Torque screws to 2.0 Nm (20 in. lbs.).
3. Install starter motor.
 - a. Torque screws to 16.0 Nm (140 in. lbs.).

Important: Route alternator wire(s) behind starter motor. DO NOT pinch wires.

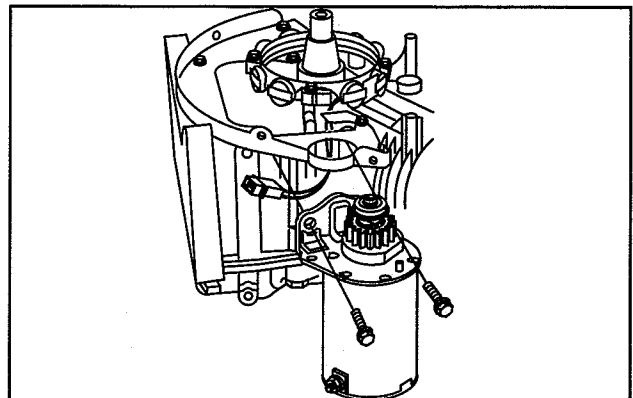

Fig. 8 – Install Alternator

4. Install ground wire onto tab terminal on armatures.

Note: Make sure wires are routed over armature mounting posts.
5. Assemble armature to engine, Fig. 9.
 - a. Mounting holes in armature are slotted. Push armature away from flywheel as far as possible and tighten one screw to hold armature in place.
6. Repeat for second armature.

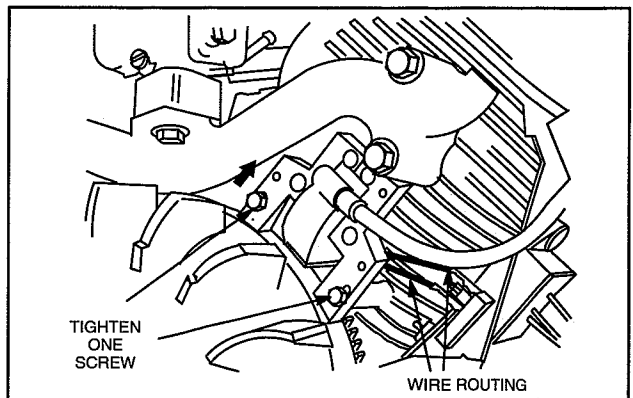

Fig. 9 – Install Armatures

INSTALL FLYWHEEL



CLEAN FLYWHEEL AND CRANKSHAFT TAPER REMOVING ALL OIL, DIRT OR GREASE.

1. Assemble flywheel to crankshaft and align keyways.
2. Insert flywheel key into crankshaft.

Torque Flywheel Nut – Engine Models 290000 – 303000

1. Install starter hub (if equipped), washer and flywheel nut.
2. Place flywheel strap wrench, Tool #19433 around outer rim of flywheel, Fig. 10.
3. Torque flywheel nut to 175.0 Nm (125 ft. lbs.).

Torque Flywheel Nut – Engine Models 350000 – 380000

1. Install washer and flywheel nut.
2. Assemble flywheel holder, Tool #19321 to retainer.
3. Torque flywheel nut to 175.0 Nm (125 ft. lbs.), Fig. 11.
 - a. Install starter hub and screw (if equipped), and torque to 48.0 Nm (35 ft. lbs.).

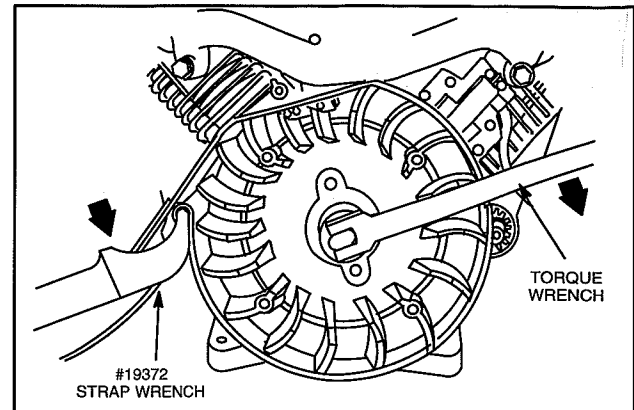

Fig. 10 – Torque Flywheel Nut

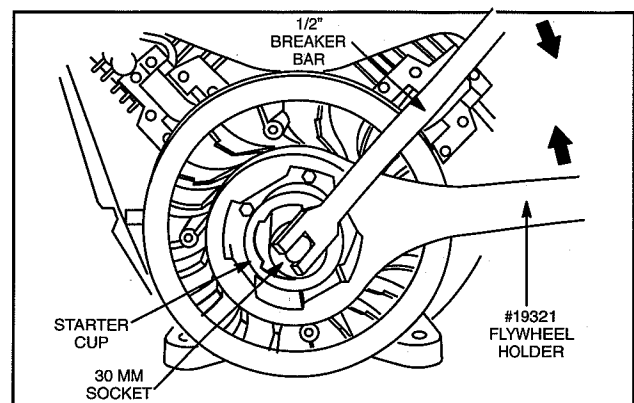

Fig. 11 – Torque Flywheel Nut

Adjust Armature Air Gap

1. Rotate flywheel until magnet is under armature laminations.
2. Place thickness gauge .008" – .012" (0.20 – .30 mm) between magnet and armature laminations, Fig. 12.
3. Loosen mounting screw so magnet will pull armature down against thickness gauge.
 - a. Torque screws to 3.0 Nm (25 in. lbs.).
4. Rotate flywheel to remove thickness gauge.
5. Repeat for second armature.

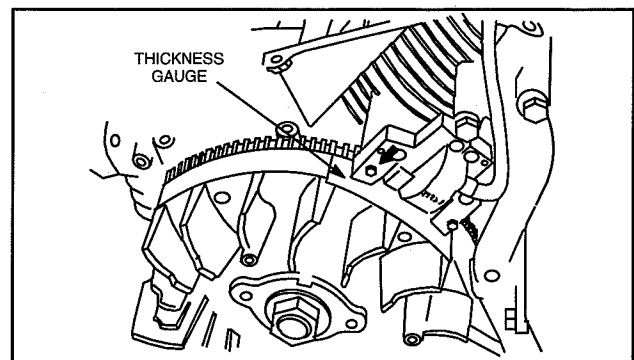

Fig. 12 – Adjust Air Gap

INSTALL CYLINDER HEADS

1. Install cylinder head with new gasket, Fig. 13.

Note: Engines manufactured before 94050100 were equipped with sealing washers under #1 and #3 cylinder head bolts.
2. Lubricate threads of head bolts with Valve Guide Lubricant #93963.
 - a. Torque bolts in sequence shown to 19.0 Nm (165 in. lbs.).
3. Insert push rods into recess in tappets.

Note: Exhaust valve push rods are aluminum.

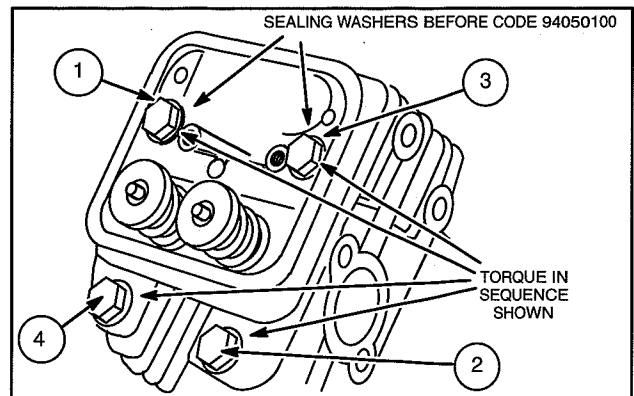

Fig. 13 – Install Cylinder Head

Install Rocker Arms – Current Style

1. Lubricate rocker arm supports with clean engine oil.
2. Assemble rocker studs, rocker arm supports and rocker arms to cylinder head, Fig. 14.
 - a. Torque studs to 11.0 Nm (100 in. lbs.).

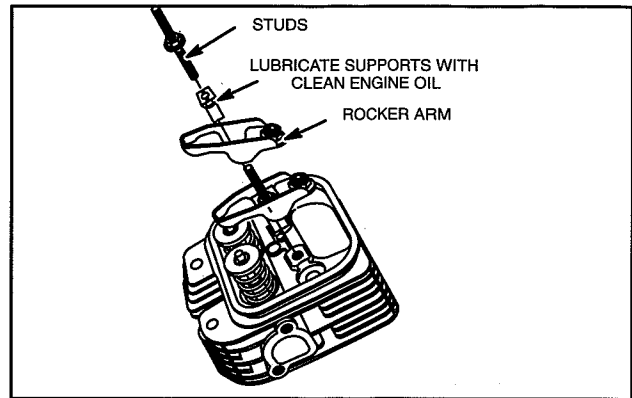

Fig. 14 – Install Rocker Arms – Current Style

Install Rocker Arms – Early Style

Note: Rocker shaft support holes are offset. Install with holes facing ends of rocker shaft, Fig. 15.

1. Lubricate rocker arms and shaft with clean engine oil.
2. Assemble rocker arms, shaft, supports and studs and install on cylinder head, Fig. 15.
 - a. Torque studs to 16.0 Nm (140 in. lbs.).

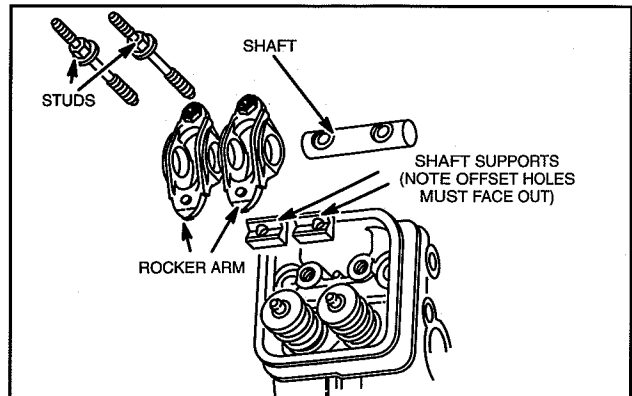

Fig. 15 – Install Rocker Arms – Early Style

Install Push Rods

1. Compress valve spring with rocker arm and insert push rod into rocker arm socket, Fig. 16.
- Be sure push rods remain seated in recess in tappets.

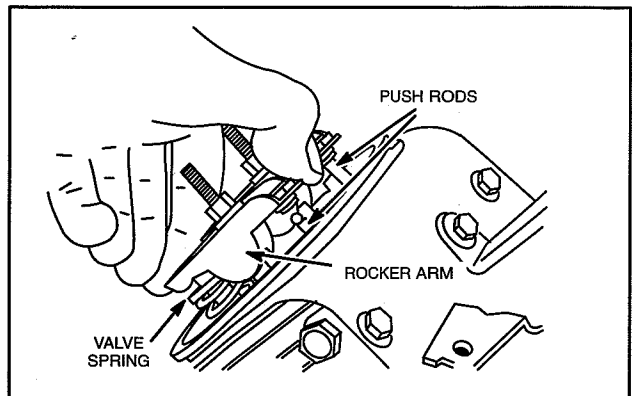

Fig. 16 – Install Push Rods

Adjust Valve Clearance

1. Set No. 1 cylinder at 6 mm (1/4") past TDC, compression stroke.
 - a. Adjust valves and check, Fig. 17.
- Valve Clearance (cold) IN and EX 0.13 mm (.005").**
- b. Torque lock nut and adjusting screw to 7.0 Nm (60 in. lbs.).
2. Repeat for No. 2 cylinder.

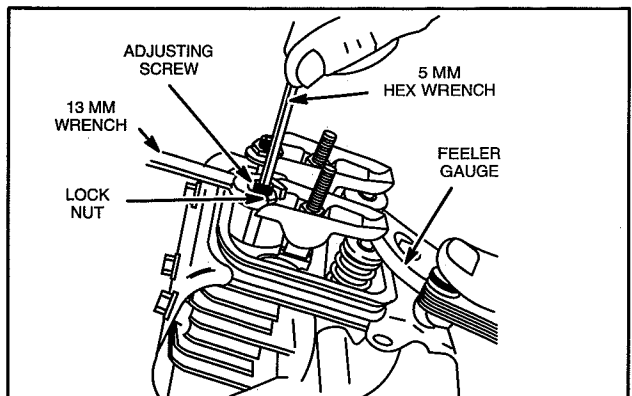

Fig. 17 – Adjust Valve Clearance

3. Install valve covers with new gaskets and valve cover seals, Fig. 18.
 - a. Torque nuts to 3.0 Nm (25 in. lbs.).

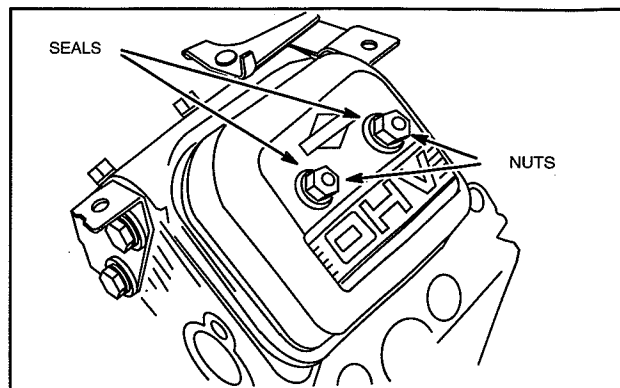

Fig. 18 – Install Valve Covers

GENERAL ASSEMBLY

1. Install cylinder shields and valley cover.
 - a. Torque screws to 7.0 Nm (65 in. lbs.).
 - b. Connect ground wire harness to stop switch terminal.
2. Assemble governor lever to governor shaft. DO NOT tighten nut at this time.
3. Install governor control bracket.
 - a. Torque screws to 16.0 Nm (140 in. lbs.).
4. Install exhaust manifold.
 - a. Torque screws to 16.0 Nm (140 in. lbs.).

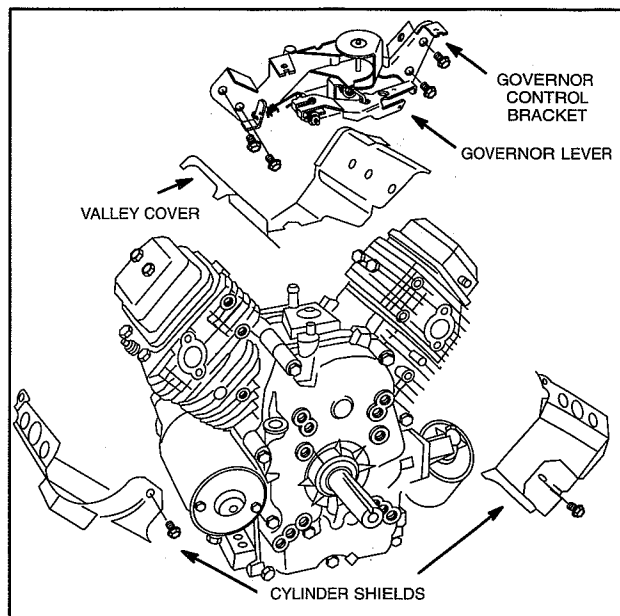

Fig. 19 – General Assembly

5. Install air cleaner support and choke bracket.
 - a. Torque screws to 7.0 Nm (65 in. lbs.).
6. Install intake manifold with new gaskets.
 - a. Torque screws to 16.0 Nm (140 in. lbs.).
 - b. Assemble governor link and spring to carburetor.

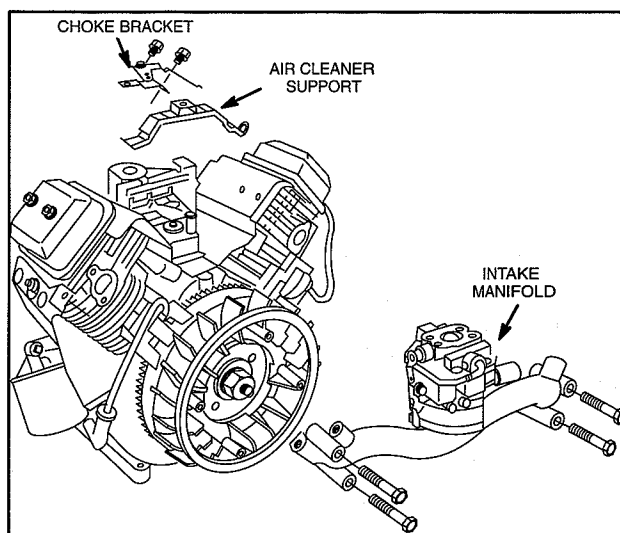

Fig. 20 – General Assembly

7. Install blower housing.
 - a. Torque 6mm screws to 7.0 Nm (65 in. lbs.).
 - b. Torque 8mm screws to 16.0 Nm (140 in. lbs.).
8. Install carburetor cover.
9. Install rotating screen.

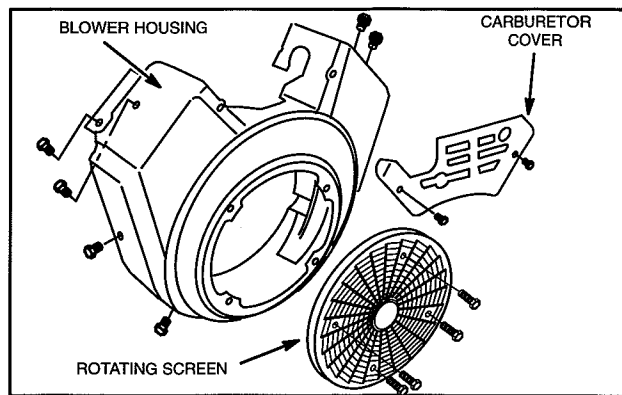

Fig. 21 – Install Blower Housing

10. Install air cleaner base with new mounting gasket.
 - a. Torque screws to 7.0 Nm (65 in. lbs.).
11. Assemble air cleaner.
12. Install spark plugs.
 - a. Torque spark plugs to 23.0 Nm (200 in. lbs.).

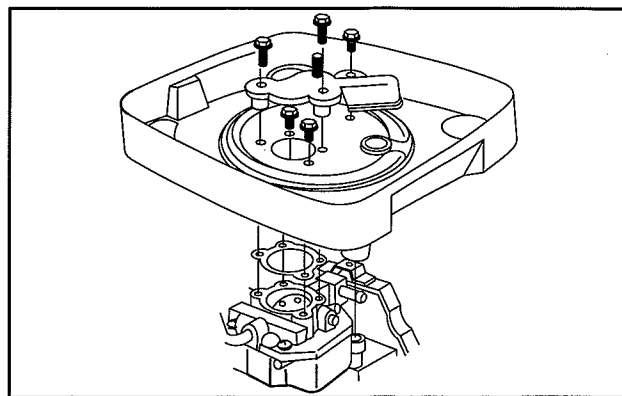

Fig. 22 – Install Air Cleaner Base

ADJUST GOVERNOR



WARNING: BEFORE STARTING OR RUNNING ENGINE, STATIC ADJUSTMENT OF THE GOVERNOR MUST BE COMPLETED! FAILURE TO MAKE THE STATIC ADJUSTMENTS FIRST COULD RESULT IN ENGINE OVERSPEEDING WHICH MAY RESULT IN ENGINE DAMAGE, PROPERTY DAMAGE OR PERSONAL INJURY.

Static Governor Adjustment

1. With governor lever nut loose, push on governor lever until throttle is wide open. **Do not bend governor link or distort governor lever.**
2. Rotate governor shaft counter-clockwise as far it will go, Fig. 23.
 - a. Torque governor nut to 8.0 Nm (70 in. lbs.).
3. Install throttle and choke control cables and check for proper operation.

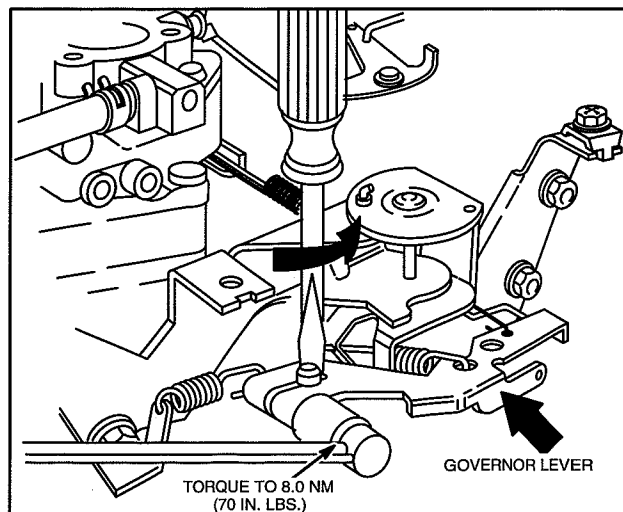
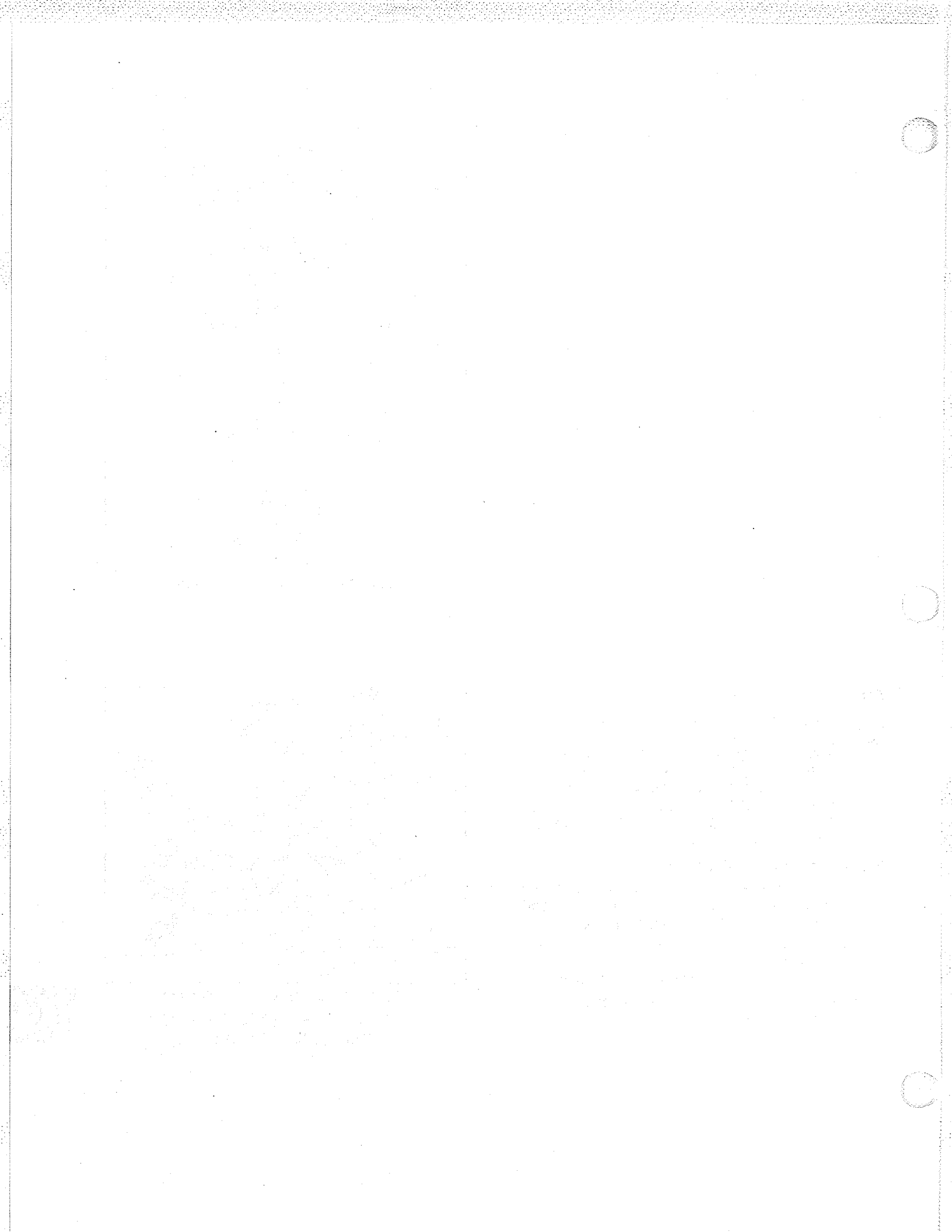

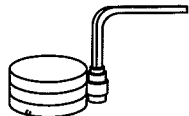
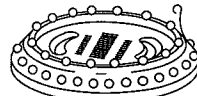
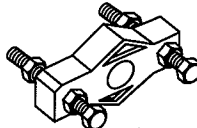
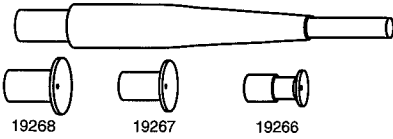
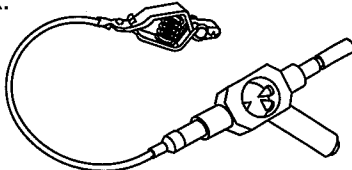

Fig. 23 – Static Governor Adjustment
SEE SECTION 3 FOR CARBURETOR
ADJUSTMENT PROCEDURE.





Section 14

TOOLS

It is assumed that Briggs & Stratton Authorized Service Centers have common hand tools to repair engines. All Briggs & Stratton Authorized Service Centers are required to have Tool Kit #19300. Tools listed below are used on OHV twin cylinder engines and are part of Tool Kit #19300.

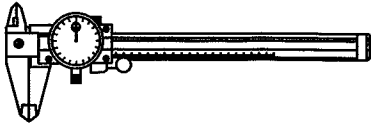
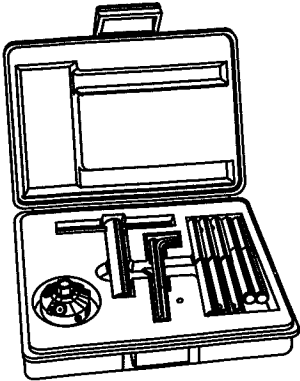

| DESCRIPTION | TOOL NO. | USE |
|--|----------|--|
| RING COMPRESSOR | 19070 | Install piston and rings.  |
| TACHOMETER | 19200 | Set correct idle and top no load RPM.  |
| FLYWHEEL PULLER | 19203 | Remove flywheel.  |
| VALVE LAPPER | 19258 | Lap valve face to valve seat face.  |
| IGNITION TESTER | 19368 | Check for ignition spark.  |
| VALVE GUIDE LUBRICANT (Anti-Seize Compound) | 93963 | Lubricate valve stems and valve guides, spark plug threads, muffler bolts and cylinder head bolts.  |
| CLOVER® VALVE LAPPING COMPOUND | 94150 | Lapping valves  |

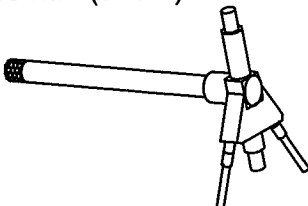
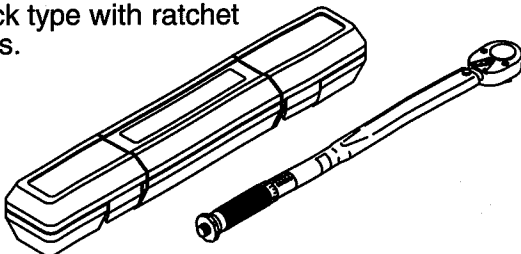

The following special tools are required for Briggs & Stratton Authorized Service Centers, in addition to Tool Kit #19300.

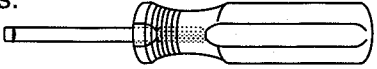
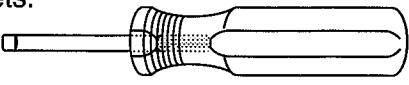
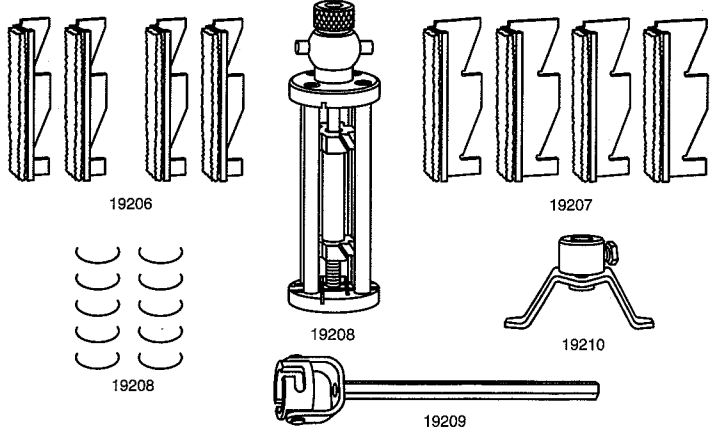
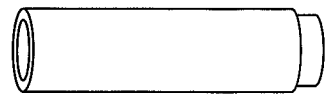
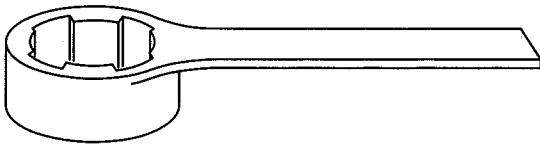
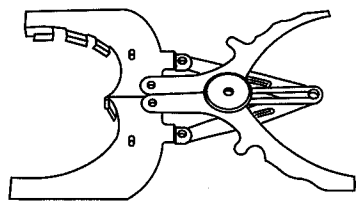
| DESCRIPTION | TOOL NO. | USE |
|-------------------------|----------|---|
| DIAL CALIPER | 19199 | Measure engine wear. Range 0" to 6" Accurate to .001"  |
| VALVE SEAT CUTTER KIT | 19237 | Restore valve seats. 30 and 45 Seat Angles.  |
| TORQUE WRENCH | 19393 | Accurately torque Connecting Rods, Cylinder Heads, Sumps, Crankcase Covers Range 0 to 300 in. lbs.  |
| GAUGE, TELESCOPING | 19404 | Measure cylinder bores for wear. Range 51 mm (2") to 89 mm (3-1/2").  |
| FT. POUND TORQUE WRENCH | 19434 | Adjustable click type with ratchet 0 – 150 Ft. Lbs.  |

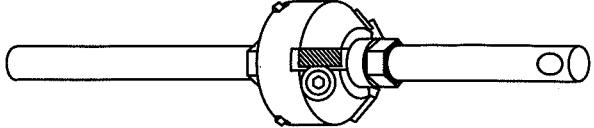
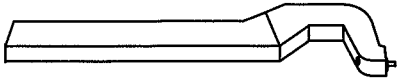
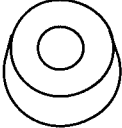

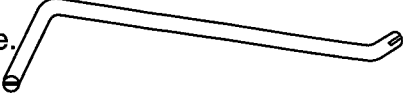
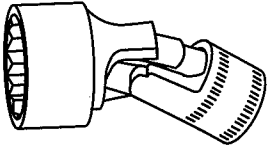
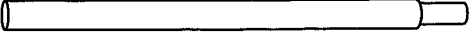
The following tools, while not required, are recommended for complete engine repair.

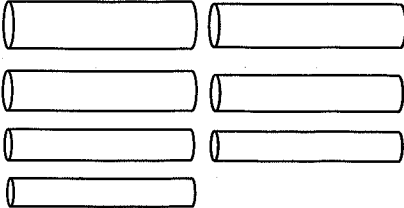
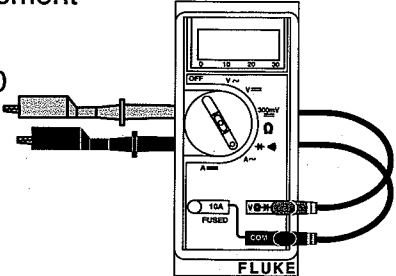
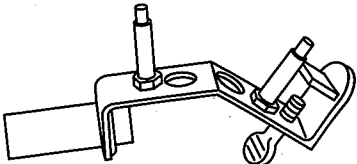
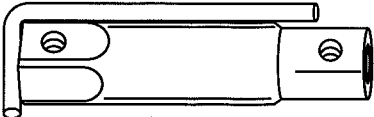
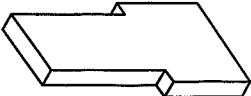

| DESCRIPTION | TOOL NO. | USE |
|------------------|----------|--|
| SCREWDRIVER | 19061 | Remove carburetor jets.  |
| SCREWDRIVER | 19062 | Remove carburetor jets.  |
| HONE SET | 19205 | Resize cylinder bores to .25 mm (.010"), .51 mm (.020"), .76 mm (.030") Oversize.  |
| CYLINDER SUPPORT | 19227 | Remove and install magneto main bearing. Install oil seals.  |
| FLYWHEEL HOLDER | 19321 | For Engine Model 350000 flywheels  |
| RING EXPANDER | 19340 | Remove and install piston rings.  |

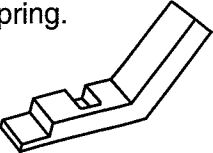
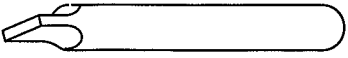
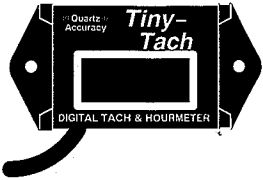
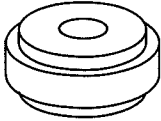
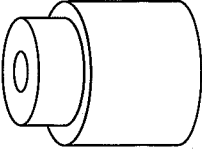
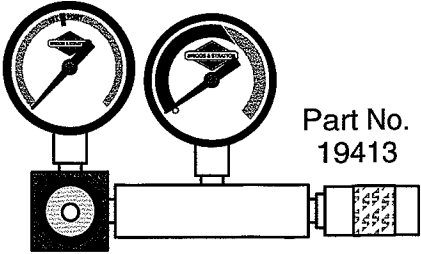

| DESCRIPTION | TOOL NO. | USE |
|-------------------------|----------|---|
| VALVE SEAT CUTTER | 19343 | Use with 19237.  |
| ROLL PIN DRIVER | 19344 | Install roll pin in magneto main bearing.  |
| REAMER PILOT GUIDE | 19345 | Use with 19346.  |
| VALVE SPRING COMPRESSOR | 19347 | Remove and install valve springs.  |
| BEARING DRIVER | 19349 | Replace magneto main bearing (Engines built before 97050100).  |
| TANG BENDER | 19352 | Adjust governor tangs for top no load RPM and governed idle.  |
| UNIVERSAL SOCKET | 19353 | 13 mm, 12 point, 1/4" Drive. For removing electric starter mounting screws.  |
| BUSHING DRIVER | 19367 | Remove valve guides.  |

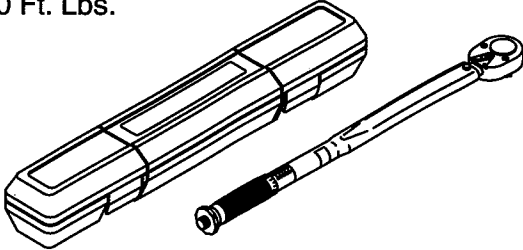
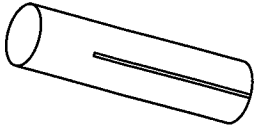
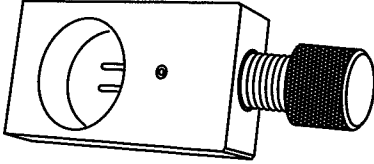
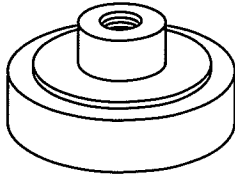
| DESCRIPTION | PART NO. | USE |
|--------------------|----------|--|
| SEAL PROTECTOR KIT | 19356 | Protects oil seals when installing crankshafts and crankcase covers.  |
| DIGITAL MULTIMETER | 19464 | Measure electrical equipment AC Volts, 0 to 750 DC Volts, 0 to 1000 Ohms, 0 to 320,000,000 AC & DC Amps, 0 to 10 continuous 0 to 20 for 30 Seconds Audible Diode Test Audible Continuity Test Auto Ranging  <p>Replacement Fuse: Order Part# 19449</p> |
| DC SHUNT | 19359 | Use with Digital Multimeter for measuring current draw of 12 volt electric starter motors and output of 16 and 20 Amp regulated alternators.  |
| SPARK PLUG WRENCH | 19374 | Remove 5/8" hex head spark plugs.  |
| PLUG GAUGE | 19380 | Check main bearings for wear.  |
| PLUG GAUGE | 19382 | Check valve guides for wear.  |

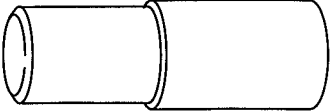
| DESCRIPTION | PART NO. | USE |
|--------------------------------|----------|--|
| PLUG GAUGE | 19384 | Check cam gear bearing for wear (mag. side).  |
| ADJUSTMENT GAUGE | 19385 | Adjust secondary governor spring.  |
| PLUG GAUGE | 19386 | Check cam gear bearing for wear (pto side).  |
| DIGITAL TACHOMETER & HOURMETER | 19389 | Meter displays RPM while engine is running. When engine is stopped, meter displays elapsed time.  |
| PILOT | 19396 | For removing and installing ball bearings. Use with 224061 washer and 19318 puller screw.  |
| DRIVER | 19401 | For removing and installing ball bearings. Use with 224061 washer and 19318 puller screw.  |
| LEAKDOWN TESTER | 19413 | Used to test the sealing capabilities of the compression components.  |

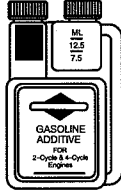
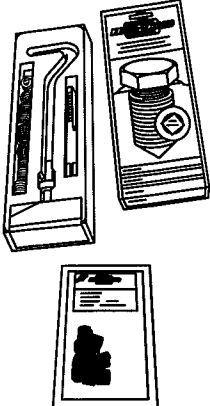
| DESCRIPTION | PART NO. | USE |
|--------------------------|----------|---|
| VALVE GUIDE DRIVER | 19416 | For installing valve guides  |
| FLYWHEEL STRAP WRENCH | 19433 | Hold flywheel while removing and torquing flywheel nut. Note: Replacement strap is available separately. Order Part #19448.  |
| FT. POUND TORQUE WRENCH | 19434 | Adjustable click type with ratchet 0-150 Ft. Lbs.  |
| C-RING INSTALLATION TOOL | 19435 | For installing new C-ring on starter motor  |
| C-RING REMOVAL TOOL | 19436 | For removing C-ring on starter motor when replacing starter motor drive. Note: Replacement drive pins available separately. Order Part# 19447.  |
| BEARING SUPPORT TOOL | 19440 | For removing and installing ball bearings. Use with 224061 washer and 19318 puller screw.  |

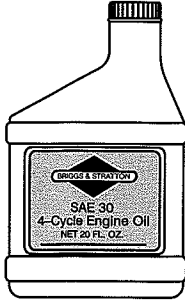
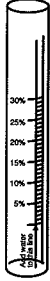
| DESCRIPTION | PART NO. | USE |
|-----------------------|--------------------------------------|--|
| VALVE GUIDE REAMER | 19444 | Ream valve guides  |
| BEARING DRIVER | 19450 | Replace magneto main bearing. (Engines built after 97043000)  |
| HEAVY DUTY TOWELS | 100054 |  |
| GASOLINE ADDITIVE | 100001 | Prevents gum & varnish. Stabilizes fuel for storage.  |
| FIX-A-THREAD KITS | 100010 100011 100012 100013 | For repairing damaged and stripped threads Thread Repair Kit M5x.8 Thread Repair Kit M6x1 Thread Repair Kit M8x1.25 Thread Repair Kit 14 mm Spark Plug – 3/4" |
| THREAD INSERT REFILLS | 100017 100018 100019 100021 | M5x.8 Refill M6x1 Refill M8x1.25 Refill 14mm Spark Plug Refill – 3/4"  |

| DESCRIPTION | PART NO. | USE |
|--------------------|----------|--|
| 30 WEIGHT | 100005 | SAE 30 weight oil (20 oz.)  |
| GASOLINE TESTER | 100023 | Use to determine the alcohol contents in gasoline.  |
| CARB/CHOKE CLEANER | 100042 | Quickly dissolves carburetor deposits (16 oz.)  |

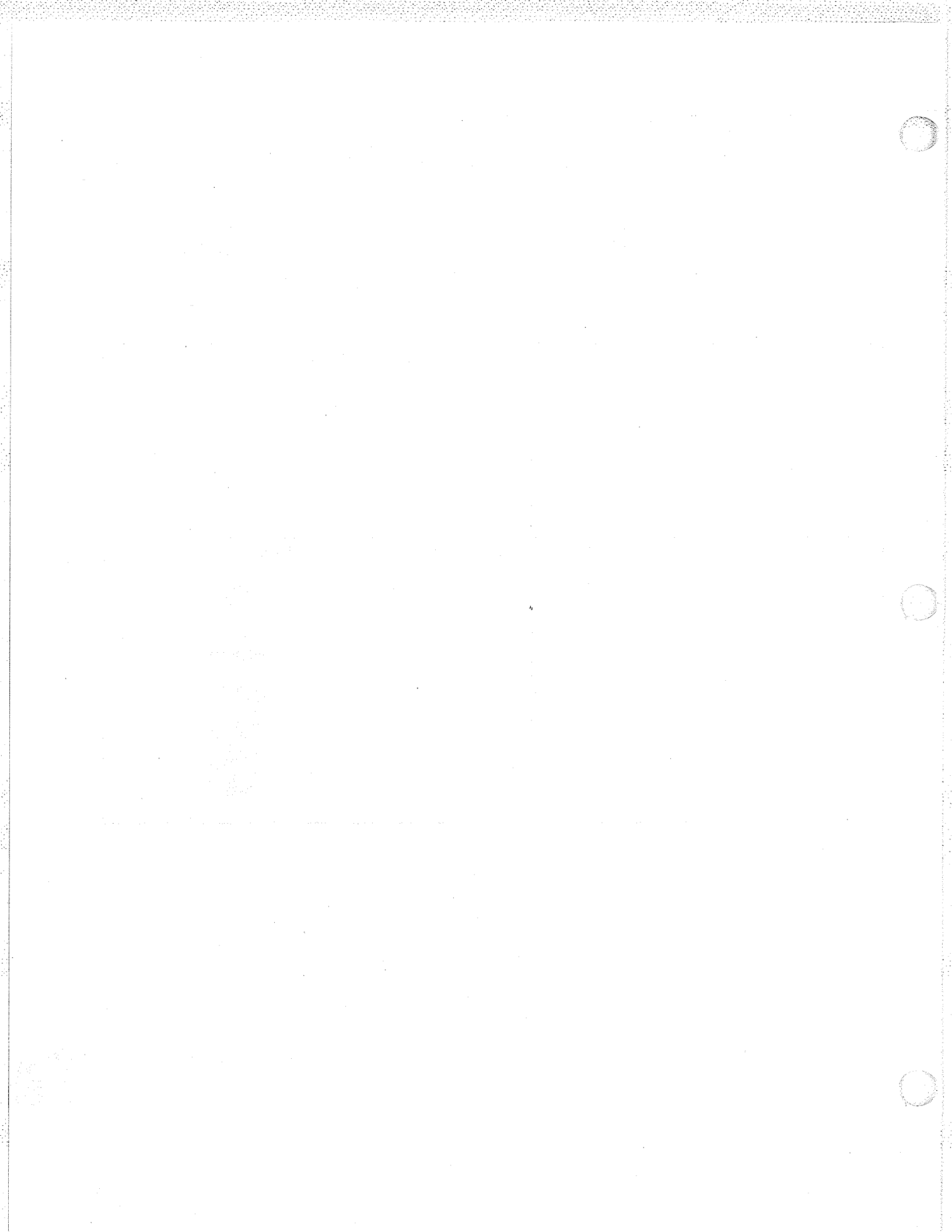

Copyright © 1998 by Briggs & Stratton Corporation

All rights reserved. No part of this material may be reproduced or transmitted, in any form or by any means, electronic or mechanical, including photocopying, recording or by any information storage and retrieval system, without permission in writing from Briggs & Stratton Corporation.



***Repair Manuals for other
Briggs & Stratton Engines, order:***

270962 – Single Cylinder 4-Cycle Engines

271172 – 4-Cycle Twin Cylinder Engines

273521 – Intek™ V-Twin OHV Engines

272147 – Single Cylinder OHV Engines

274008 – Intek™ Single Cylinder OHV Engines

800100 – 2-Cycle Single Cylinder Engines



0 24847 79687 2

BRIGGS & STRATTON CORPORATION
Milwaukee, WI 53201

Part No. 272144-12/98 Printed in U.S.A.
www.briggsandstratton.com