

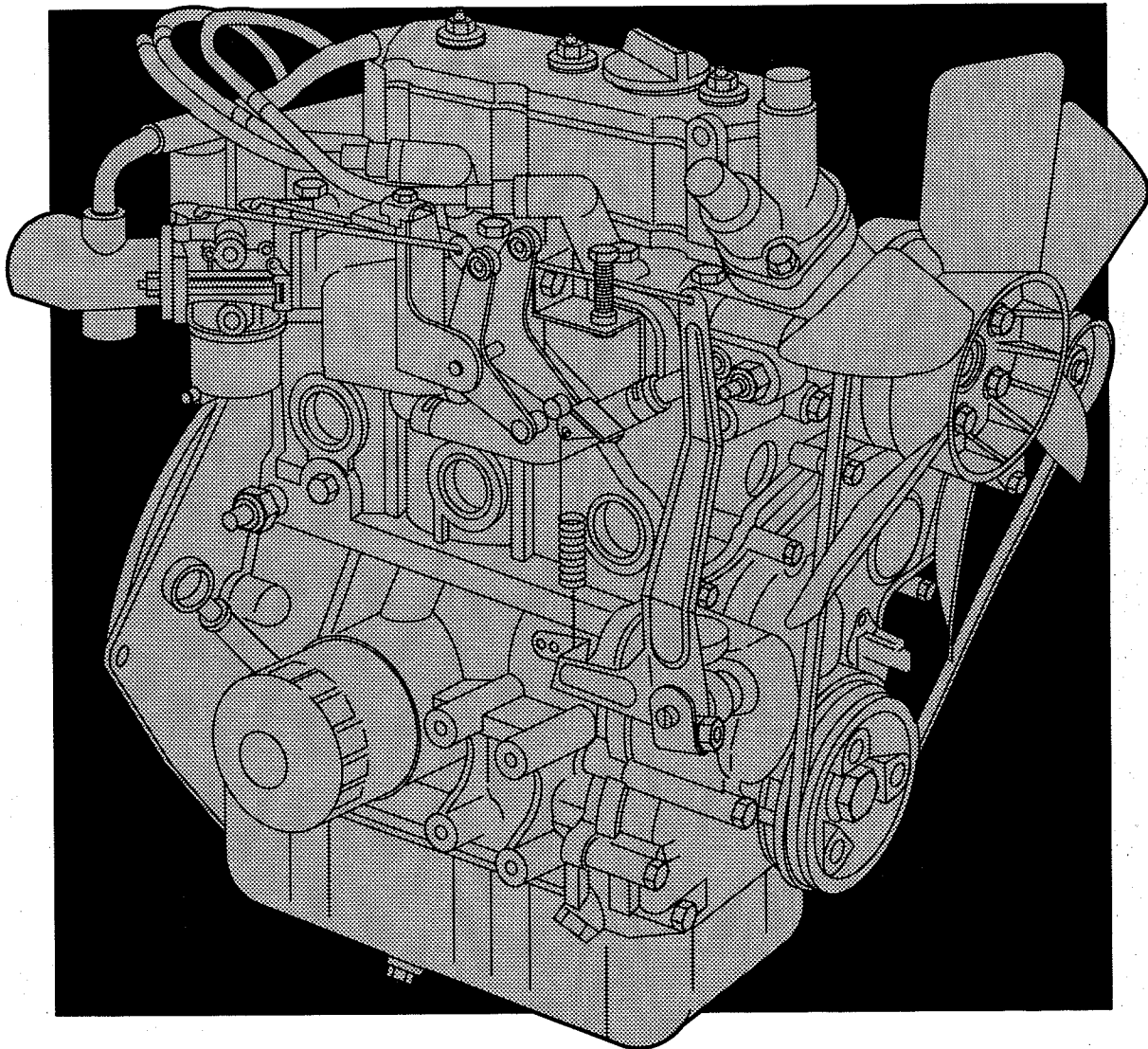

REPAIR MANUAL

For 3 Cylinder Liquid-Cooled Gasoline Engines



FOREWORD

The information, procedures and specifications provided in this repair manual are current as of the date of publication and subject to change without notice. Appropriate changes will be included in the next revision of this manual.

Note: Manufacturing standards may vary from service specifications. Always refer to the service procedures and specifications in this manual when engine service is required.

GENERAL REPAIR INSTRUCTIONS

Before attempting a B&SD engine overhaul or a tune-up, it is necessary that your shop be equipped with proper tools, equipment and mechanics who are thoroughly familiar with Briggs & Stratton engine design and construction. With your shop thus equipped, this book will serve as a guide in performing the various steps necessary to do a complete and satisfactory job. Use only genuine replacement parts. Always use recommended service tools.

This engine is designed and manufactured using metric dimensions. The English equivalents provided may have been rounded up or down to the closest numerical interpretation of the metric dimension.

The terms Inspect, Check, Test and Replace are used as follows:

INSPECT – Visual inspection – look for signs of wear, scoring, cracks, stripped threads, etc.

CHECK – Measure by means of plug gauges, micrometer, feeler gauges, scale, etc.

TEST – Analyze with proper test equipment.

REPLACE – This usually means to take off the old part and reassemble it or replace it with a new one.

Disassembly

As engine is being disassembled, mark parts which are part of an assembly, to prevent interchanging. Arrange parts in an orderly manner, keeping parts which are an assembly together.

Visually inspect each part as it is removed – look for signs of wear, scoring, cracks, stripped threads, etc.

Inspection and Measurement

Carefully check parts that can be reconditioned and/or reused.

Replace any parts that are not within specification.

Clean parts to be reused

Clean or wash disassembled parts.

Assemble

Use a torque wrench to torque bolts and nuts to required specifications.

Replace all gaskets, cotter pins, oil seals and O-rings.

ABBREVIATIONS

Abbreviation	Meaning
ASSY	Assembly
BDC	Bottom Dead Center
EX	Exhaust
ID	Inside Diameter
IN	Intake
LH	Left Hand
MP	Multi-purpose

Abbreviation	Meaning
OD	Outside Diameter
OPT	Optional
O/S	Oversize
RH	Right Hand
SAE	Society of Automotive Engineers
TDC	Top Dead Center
U/S	Undersize

Copyright © 2000 by Briggs & Stratton Corporation

All rights reserved. No part of this material may be reproduced or transmitted, in any form or by any means, electronic or mechanical, including photocopying, recording or by any information storage and retrieval system, without permission in writing from Briggs & Stratton Corporation.

TABLE OF CONTENTS

See pages II and III for section contents

GENERAL INFORMATION	Section 1
CYLINDER HEAD AND VALVES	Section 2
GOVERNOR, TIMING GEARS AND GEAR CASE	Section 3
FLYWHEEL AND REAR SEAL RETAINER	Section 4
CYLINDER BLOCK DISASSEMBLY	Section 5
CYLINDER BLOCK INSPECTION AND REPAIR	Section 6
CRANKSHAFT, CAMSHAFT AND BEARINGS	Section 7
PISTON, RINGS AND CONNECTING ROD INSPECTION AND ASSEMBLY	Section 8
CYLINDER BLOCK ASSEMBLY	Section 9
FUEL SYSTEM AND RELATED COMPONENTS	Section 10
IGNITION, ELECTRICAL SYSTEMS	Section 11
LUBRICATION SYSTEM	Section 12
COOLING SYSTEM	Section 13
TOOLS	Section 14

1

2

3

4

5

6

7

8

9

10

11

12

13

14

SECTION CONTENTS

1 Section 1

General Information

In The Interest Of Safety
Engine Identification / Engine Views
Engine Specifications And Data
Fastener Specifications
Briggs & Stratton Numerical Number System
Maintenance Schedule

2 Section 2

Cylinder Head And Valves

Remove Cylinder Head
Disassemble Cylinder Head
Inspect And Repair.
 Cylinder Head
 Valve Guides
 Valves
Disassemble Rocker Arm Shaft
Assemble Rocker Arm Shaft
Assemble Cylinder Head
Install Cylinder Head
Adjust Valves

3 Section 3

Governor, Timing Gears And Gear Case

Remove Timing Gear Cover And Gears
Checking Gears
Remove Gear Case
Disassemble Governor Shaft
Replace Timing Gear Cover Oil Seal
Assemble Governor
Assemble Timing Gear Case And Gears
Adjust Governor
Troubleshooting
Electronic Governor
Checking Governor Actuator
Remove Governor Actuator
Install Governor Actuator

4 Section 4

Flywheel And Rear Seal Retainer

Removing Flywheel And Rear Seal Retainer
Replacing Oil Seal
Installing Rear Seal Retainer And Flywheel
Install Oil Pan

5 Section 5

Cylinder Block Disassembly

Engine Stand Fixture
Cylinder Block Disassembly

6 Section 6

Cylinder Block Inspection And Repair

Checking Cylinder Block
Replacing Camshaft Bearing
Replacing Camshaft Plug

7 Section 7

Crankshaft, Camshaft And Bearings

Checking Crankshaft
Checking Main Bearing Clearances
Checking Connecting Rod Bearing Clearances
Checking Crankshaft End Play
Checking Camshaft

8 Section 8

Piston, Rings And Connecting Rod Inspection And Assembly

Disassemble Piston And Connecting Rod
Checking Piston And Rings
Checking Piston Pin And Connecting Rod
Assemble Piston And Connecting Rod
Assemble Piston Rings To Piston

9 Section 9

Cylinder Block Assembly

Install Crankshaft
Install Pistons And Connecting Rods
General Assembly
 Oil Pickup Tube
 Rear Seal Retainer And Starter Motor
 Flywheel
Install Timing Gear Case, Camshaft And Gears
Install Oil Pan
Install Alternator

SECTION CONTENTS

10 Section 10

Carburetor And Related Components

- Manual Choke Carburetor
 - Remove Carburetor
 - Disassemble Carburetor
 - Clean And Inspect Carburetor
 - Check Throttle, Choke Shaft And Body For Wear
 - Assemble Carburetor
 - Install Carburetor
 - Carburetor Adjustment
- Automatic Choke Carburetor
 - Remove Carburetor
 - Disassemble Carburetor
 - Clean And Inspect Carburetor
 - Check Throttle, Choke Shaft And Body For Wear
 - Assemble Carburetor
 - Checking Vacuum Choke Break
 - Checking P.T.C. Heater
 - Install Carburetor
 - Install Vacuum Limiter
 - Carburetor Adjustment
- Fuel Pump Specifications
- Checking Fuel Pump Output
- Testing Fuel Pump Wiring
- Anti-Afterfire Solenoid
- Testing Anti-Afterfire Solenoid
- Testing Equipment Solenoid Wiring
- Testing Solenoid
- Fuel Filter
- Main Jet Identification

11 Section 11

Ignition, Electrical Systems

- Ignition System Components
- Test Equipment
- Testing Trigger
- Testing Ignition Module
- Testing Ignition Coils
- 14 Amp Charging System
- 14 Amp Wiring Diagram
- Test Equipment
- Testing Alternator – AC Output
- Testing Regulator–rectifier – DC Output
- Charging Indicator Circuit
- Testing Charging Indicator Bulb And Wiring
- 40 Amp Wiring Diagram
- 40 Amp Charging System

11 Section 11

Electrical Systems (continued)

- Test Equipment
- Testing Alternator – DC Output
- Disassemble Alternator
- Check Bearings
- Install Ball Bearing
- Check Rotor
- Check Brushes
- Check Regulator
- Check Rectifier
- Assemble Alternator
- Starter System
- Starter Current Draw Test
- Test Equipment
- Testing Starter
- No Load Starter Current Draw Test
- Equipment To Test Solenoid
- Testing Solenoid
- Removing Pinion Gear Assembly
- Install Pinion Gear Assembly
- Disassemble Starter Motor
- Inspect Armature Commutator
- Inspect Brushes
- Replace Brushes
- Assemble Starter

12 Section 12

Lubrication System

- Description
- Change Oil
- Change Oil Filter
- Check Oil Pressure
- Disassemble Gear Case
 - Remove Oil Pump
- Assemble Gear Case
 - Install Oil Pump
- Adjust Governor

13 Section 13

Cooling System

- General Information
- Checking Cooling System
 - Pressure Testing Cooling System
 - Testing Radiator Cap
- Changing Coolant
- Removing Thermostat
- Checking Thermostat
- Installing Thermostat
- Inspecting Water Pump
- Removing Water Pump
- Installing Water Pump

14 Section 14

Tools

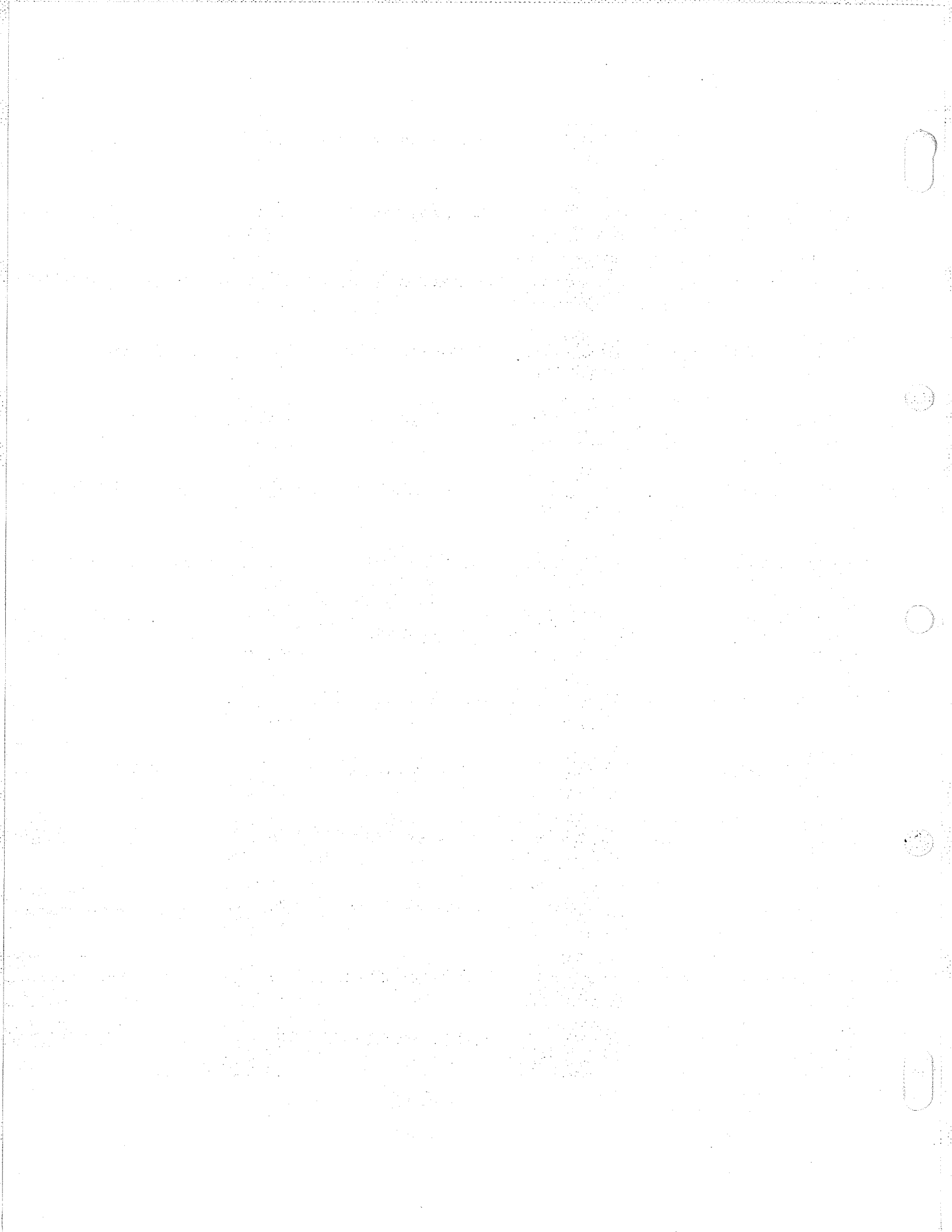



VANGUARD
3/EC
cylinder liquid cooled



Section 1 General Information

Section Contents

	Page
ENGINE IDENTIFICATION	1
IN THE INTEREST OF SAFETY	2
ENGINE VIEWS	3
ENGINE SPECIFICATIONS AND DATA	4
FASTENER SPECIFICATIONS	6
BRIGGS & STRATTON NUMERICAL NUMBER SYSTEM	7
MAINTENANCE SCHEDULE	8

ENGINE IDENTIFICATION NUMBERS

The engine model and type number are located on the valve cover, Fig. 1. The serial number is stamped into the right side of the cylinder block, behind the carburetor, Fig. 2.

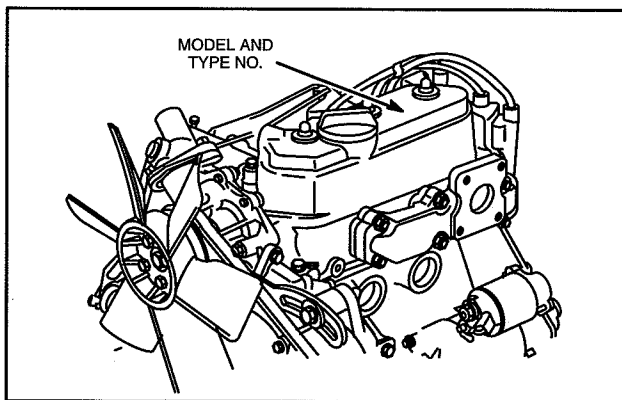

Fig. 1 – Engine Model And Type Number

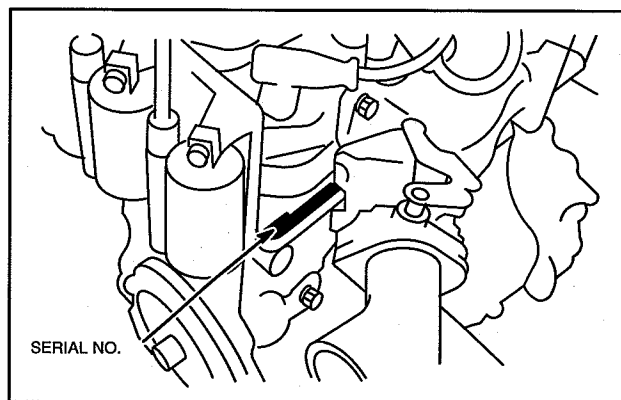

Fig. 2 – Engine Serial Number

GENERAL INFORMATION

IN THE INTEREST OF SAFETY



THIS SAFETY ALERT SYMBOL INDICATES THAT THIS MESSAGE INVOLVES PERSONAL SAFETY. SIGNAL WORDS DANGER, WARNING AND CAUTION INDICATE HAZARD DEGREE. DEATH, PERSONAL INJURY AND/OR PROPERTY DAMAGE MAY OCCUR UNLESS INSTRUCTIONS ARE FOLLOWED CAREFULLY.



WARNING: DO NOT

1. DO NOT run engine in an enclosed area. Exhaust gases contain carbon monoxide, an odorless and deadly poison.
2. DO NOT place hands or feet near moving or rotating parts. Keep all guards in place.
3. DO NOT place hands or feet near electric cooling fan (if equipped). Fan may start suddenly, depending on coolant temperature.
4. DO NOT store, spill, or use gasoline near an open flame, or devices such as a stove, furnace, or water heater which use a pilot light or devices which can create a spark.
5. DO NOT refuel indoors where area is not well ventilated. Outdoor refueling is preferred.
6. DO NOT fill fuel tank while engine is running. Allow engine to cool for 2 minutes before refueling. Store fuel in approved, correct color safety containers.
7. DO NOT remove fuel tank cap while engine is running.
8. DO NOT operate engine when smell of gasoline is present or other explosive conditions exist.
9. DO NOT operate engine if gasoline is spilled. Move machine away from the spill and avoid creating any ignition until the gasoline has evaporated and dissipated.
10. DO NOT smoke when filling fuel tank.
11. DO NOT choke carburetor to stop engine. Whenever possible, gradually reduce engine speed before stopping.
12. DO NOT run engine at excessive speeds. This may result in injury.
13. DO NOT tamper with governor springs, governor links or other parts which may increase the governed engine speed.
14. DO NOT tamper with the engine speed selected by the original equipment manufacturer.
15. DO NOT check for spark with spark plugs or spark plug wires removed. Use an approved tester.
16. DO NOT crank engine with spark plug removed. The fuel mixture exits the spark plug hole and can be ignited outside the engine by the loose spark plug or spark plug wire. If engine is flooded, place throttle in "FAST" position and crank until engine starts.
17. DO NOT operate engine with a damaged muffler or without muffler. Inspect periodically and replace, if necessary. If engine is equipped with muffler deflector(s), inspect periodically and replace, if necessary, with correct deflector(s).
18. DO NOT operate engine with an accumulation of grass, leaves, dirt or other combustible material in the muffler area.
19. DO NOT use starting fluid.
20. DO NOT use this engine on any forest covered, brush covered, or grass covered unimproved land unless a spark arrester is installed on the muffler. The arrester must be maintained in effective working order by the operator. In the State of California the above is required by law (Section 4442 of the California Public Resources Code). Other states may have similar laws. Federal laws apply on federal lands.
21. DO NOT touch hot muffler(s) or cylinder(s) because contact may cause burns.
22. DO NOT remove the radiator cap while the engine is hot. To avoid scalding hot coolant or steam blowing out of the radiator, use extreme care when removing the radiator cap. If possible, wait for engine to cool. If not possible, wrap a thick rag around cap while removing. To release pressure, slowly turn cap counter clockwise to the first stop. When all pressure has been released, press down on cap and continue turning.
23. DO NOT start or run engine with air cleaner or air cleaner cover removed.



WARNING: DO

1. ALWAYS DO remove the wires from the spark plugs when servicing the engine or equipment TO PREVENT ACCIDENTAL STARTING. Disconnect the negative wire from the battery terminal.
2. DO wear eye protection when operating or repairing equipment.
3. DO keep governor parts free of grass and other debris which can affect engine speed.
4. DO examine muffler(s) periodically to be sure it is functioning effectively. A worn or leaking muffler(s) should be repaired or replaced as necessary.
5. DO use fresh gasoline. Stale fuel can gum carburetor and cause leakage.
6. DO check fuel lines and fittings frequently for cracks or leaks. Replace if necessary.

NOTE: Use Original Briggs & Stratton-Daihatsu Service Replacement Parts when servicing your engine. Authorized Briggs & Stratton-Daihatsu Service Centers carry a stock of such parts. The use of Briggs & Stratton-Daihatsu parts preserves the original design of your engine. Imitation replacement parts may not fit or function as original Briggs & Stratton-Daihatsu parts and can expose the operator to potential personal injury. Contact any Authorized Briggs & Stratton-Daihatsu Service Center for Original Briggs & Stratton-Daihatsu Replacement Parts.

ENGINE VIEWS

1

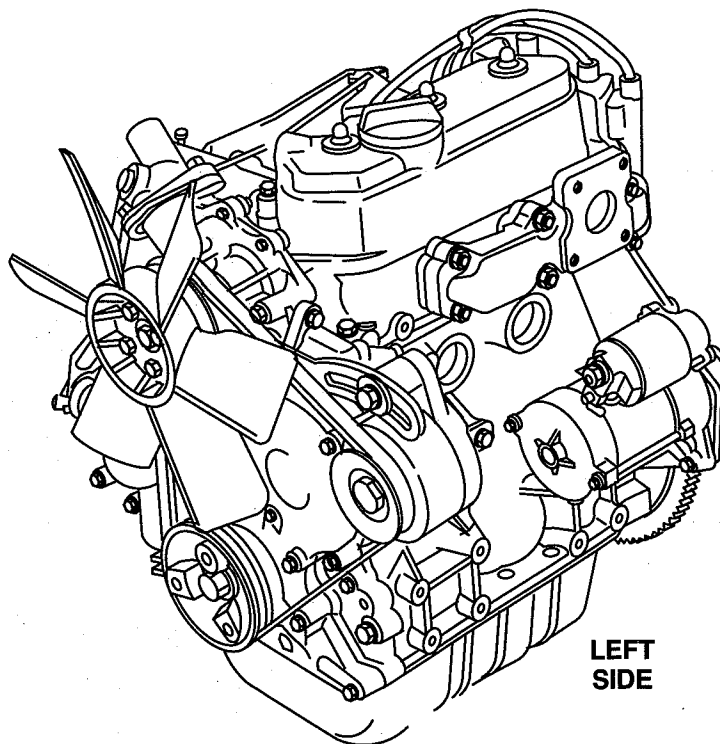
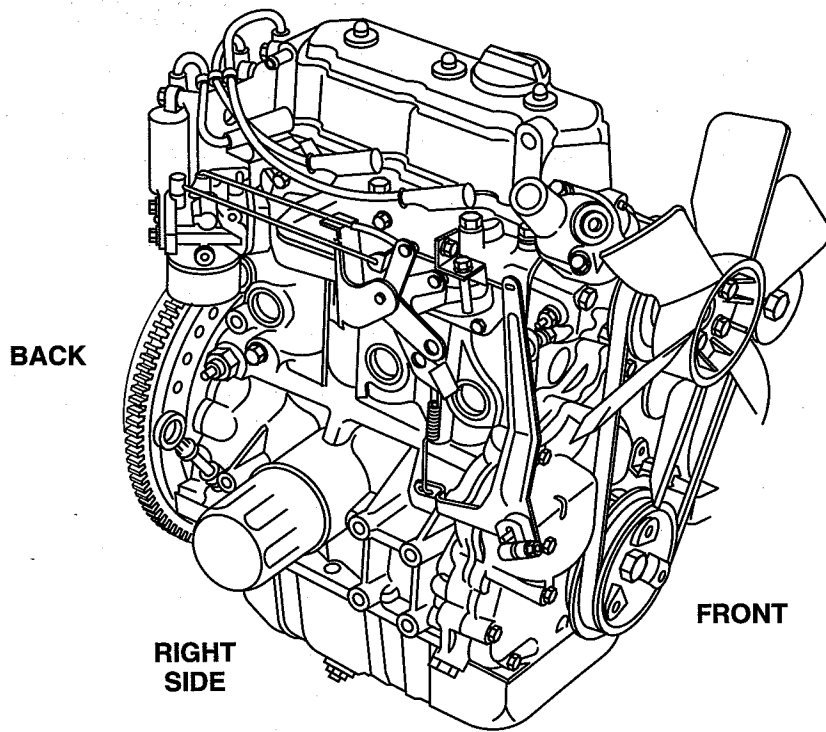

GENERAL INFORMATION

ENGINE SPECIFICATIONS

1

General	Model		430447	580447	
	Type		Gasoline, 4-cycle, 3 cylinder, in-line, liquid cooled		
	Valve mechanism		OHV, gear driven		
	Bore x stroke mm (in)		68 x 64 (2.680 x 2.520)	72 x 78 (2.834 x 3.070)	
	Piston displacement cc (cu in)		697 (42.5)	952 (58.1)	
	Firing order		1-2-3 (front, center, back)		
	Compression ratio		8.6 : 1		
	Compression pressure (normal)		14.0 kg/cm ² (200 psi) @ 400 rpm Engine at operating temperature – all spark plugs removed		
	Compression pressure (minimum)		11.0 kg/cm ² (155 psi) @ 400 rpm Engine at operating temperature – all spark plugs removed		
	Dimensions (L x W x H) mm (in)		435 x 395 x 492 (17.1x15.5x19.4)	435x395x502 (17.1x15.5x19.7)	
	Dry weight kg (lbs)		60 (132)	62 (137)	
Cylinder Head	Type		Single piece casting		
	Material		Aluminum		
Valve Specifications	Valve seat angle	Intake		30°	
		Exhaust		30°	
	Valve timing	Intake	Opens	10° BTDC	235°
			Closes	45° ABDC	
		Exhaust	Opens	45° BBDC	235°
			Closes	10° ATDC	
Valve clearance (cold)		Intake mm (in)	.18 (.007 in)		
		Exhaust mm (in)	.18 (.007 in)		
Cylinder Block & Camshaft	Cylinder block		Mono-block, three cylinder, cast iron		
	Camshaft		Carbon steel		
Connecting Rod & Piston	Connecting rod		Carbon steel		
	Piston Pin Bearing		Machined – Piston pin, press fit		
	Crankpin Bearing	Material	Replaceable insert	Aluminum alloy	
	Piston		Heat resistant aluminum alloy		
	Piston ring	Compression ring		Two, chrome plated	
Oil ring		One, combination type, chrome plated			
Crankshaft & Crankshaft Bearing	Crankshaft		One piece cast iron		
	Crankshaft main bearing	Material	Replaceable insert – Aluminum alloy		

LUBRICATING SYSTEM

Lubricating Method		Pressure lube
Oil Pump	Type	Trochoid
	Drive	Gear drive
Oil Filter	Type	Full flow, paper
Oil Capacity		3.3 ltr (3.5 qt)
Oil Pump Relief Valve Opening Pressure		4.8 Bar (70 psi)
Lubrication Oil		API SE class or higher

COOLING SYSTEM

Cooling Method		Liquid cooled, forced circulation
Coolant Capacity (engine only)		Approximately 1.8 ltr (1.9 qt)
Cooling System Pressure		1.0 – 0.75 Bar (15 – 11 psi)
Pressure Cap Capacity		0.9 Bar (13 psi).
Water Pump	Type	Centrifugal
	Drive	V-belt
Thermostat	Type	Wax pellet with bypass
	Specification	82° C (180° F)
Cooling Fan	Drive	V-belt

AIR INTAKE AND EXHAUST SYSTEM

Intake Manifold	Material	Natural aspirating	Aluminum
Exhaust Manifold	Material	Sideward exhaust	Cast Iron

FUEL SYSTEM

Fuel		Gasoline 85 octane minimum	
Fuel Pump	Type	Electric	
	Delivery Output – Minimum	350 cc/minute (12 fl. oz.)	
	Fuel Pump Pressure – Maximum	0.25 Bar (3.5 psi)	
Carburetor	Make	Aisan Kogyo Co., Ltd {Nikki-optional}	
	Type	Single barrel, Float Feed	
		Model 430447	Model 580447
Carburetor	Bore diameter	24 mm	26 mm
	Venturi diameter	17 mm	22 mm
Governor	Type	Mechanical	
		Electronic {Optional}	
Idle Speed RPM		1500 +/- 100 RPM (Idle mixture adjustment performed at 1200 RPM)	

ELECTRICAL SYSTEM

Battery	Voltage	12V (negative ground)
	Capacity	24 AH (28 AH cold)
Charging System	Alternator	28 Volt AC output – Minimum
	Regulator/rectifier	14 Amp DC output with charge indicator circuit
	Alternator {Optional}	40 Amp DC output – Internally regulated
Starter	Type	12 Volt – Solenoid activated bendix drive

IGNITION SYSTEM

Voltage		12 v (negative ground)
Type		Transistorized Ignition
Ignition Timing		10° BTDC at idle/17.5 BTDC at 3600 RPM
Spark Plug		N.G.K. BKR4E
Briggs & Stratton Daihatsu Part No. 491055		Champion RC12YC
Spark Plug	Gap	0.76 mm (.030")
Spark Plug	Thread	14 x 1.25 mm

GENERAL INFORMATION**Fastener Specifications**

Description	Wrench/Socket Size	Torque
Alternator Adjust. Bracket.	12 mm	19.0 Nm (170 in. lbs.)
Alternator (to bracket)	12 mm	19.0 Nm (170 in. lbs.)
Alternator Bracket (to block)	12 mm	19.0 Nm (170 in. lbs.)
Camshaft Gear	17 mm	41.0 Nm (30 ft. lbs.)
Camshaft Retainer	10 mm	8.0 Nm (70 in. lbs.)
Carburetor (to manifold)	10 mm	8.0 Nm (70 in. lbs.)
Coil Bracket	12 mm	20.0 Nm (180 in. lbs.)
Conn. Rod Nuts	12 mm	36.0 Nm (320 in. lbs.)
Crankshaft Pulley	19 mm	88.0 Nm (65 ft. lbs.)
Cyl. Head Bolts (8mm dia.)	12 mm	34.0 Nm (25 ft. lbs.)
Cyl. Head Bolts (9mm dia.)	12 mm	35.0 Nm (26 ft. lbs.)
Exhaust Manifold	12 mm	19.0 Nm (170 in. lbs.)
Fan Pulley	10 mm	7.0 Nm (60 in. lbs.)
Flywheel	14 mm	47.0 Nm (35 ft. lbs.)
Governor Control Bracket	10 mm	8.0 Nm (70 in. lbs.)
Governor Nut	10 mm	10.0 Nm (90 in. lbs.)
Governor Paddle	Phillips	0.9 Nm (8 in. lbs.)
Idler Gear	12 mm	25.0 Nm (220 in. lbs.)
Intake Manifold	10 mm	7.0 Nm (60 in. lbs.)
Main Bearing Screws	14 mm	61.0 Nm (45 ft. lbs.)
Oil Drain Plug	14 mm	25.0 Nm (220 in. lbs.)
Oil Pan	10 mm	8.0 Nm (70 in. lbs.)
Oil Pressure Relief Valve	19 mm	34.0 Nm (25 ft. lbs.)
Oil Pump Gear	12 mm	19.0 Nm (170 in. lbs.)
Oil Pump Pickup	10 mm	8.0 Nm (70 in. lbs.)
Rear Seal Support	10 mm	6.0 Nm (50 in. lbs.)
Rocker Arm Assy.	12 mm Deep	19.0 Nm (170 in. lbs.)
Rocker Arm Adjustment	10 mm	11.0 Nm (95 in. lbs.)
Spark Plugs	16 mm Deep	21.0 Nm (170 in. lbs.)
Starter	14 mm	40.0 Nm (30 ft. lbs.)
Starter Bracket	14 mm	34.0 Nm (25 ft. lbs.)
Starter Solenoid	10 mm	8.0 Nm (70 in. lbs.)
Starter Thru Bolts	10 mm	8.0 Nm (70 in. lbs.)
Timing Gear Case	10 mm	8.0 Nm (70 in. lbs.)
Timing Gear Cover (3 different lengths)	10 mm	8.0 Nm (70 in. lbs.)
Valve Cover	10 mm	6.0 Nm (50 in. lbs.)
Water Pump	12 mm	19.0 Nm (170 in. lbs.)

BRIGGS & STRATTON DAIHATSU NUMERICAL NUMBER SYSTEM

All Briggs & Stratton Daihatsu engines have a unique numerical designation system. Each engine is identified by a Model, Type and Code/Serial number. Example:

Model Type Code/Serial
430447 0125 01 950521150

This chart explains the numerical model designation system. It is possible to determine most of the important mechanical features of the engine by merely knowing the model number. Here is how it works.

CUBIC INCH DISPLACEMENT	FIRST DIGIT AFTER DISPLACEMENT	SECOND DIGIT AFTER DISPLACEMENT	THIRD DIGIT AFTER DISPLACEMENT	FOURTH DIGIT AFTER DISPLACEMENT
	BASIC DESIGN SERIES	CRANKSHAFT, CARBURETOR, GOVERNOR	PTO BEARING, REDUCTION GEAR, AUXILIARY DRIVE, LUBRICATION	TYPE OF STARTER
6	0 - Gas-Mechanical	0 - Horizontal Shaft	0 - Plain Bearing/DU	0 - Without Starter
8	1 - Natural Gas-Mechanical	Diesel Electronic or	Non-Flange Mount	1 - Rope Starter
9	2 - Diesel-Mechanical	Mechanical Governor	1 - Plain Bearing	2 - Rewind Starter
10	3 - Gas-Electronic	1 - Horizontal Shaft	Flange Mounting	3 - Electric Starter Only
11	4 - Natural Gas-Electronic	Vacu-Jet Carburetor	2 - Sleeve Bearing	120 Volt Gear Drive
12	5 - Diesel-Electronic	Pneumatic Governor	Flange Mounting	4 - Electric Starter/Generator
13	6	2 - Horizontal Shaft	Splash Lube	12 Volt Belt Drive
16	7	Pulsa-Jet Carburetor	3 - Ball Bearing	5 - Electric Starter Only
17	8	Pneumatic or Mechanical	Flange Mounting	12 Volt Gear Drive
18	9	Governor	Splash Lube	6 - Alternator Only
19	A to Z	3 - Horizontal Shaft	4 - Ball Bearing	7 - Electric Starter
22		Flo-Jet Carburetor	Flange Mounting	12 Volt Gear Drive
23		Pneumatic Governor	Pressure Lubrication on	With Alternator
24		4 - Horizontal Shaft	Horizontal Shaft	8 - Vertical Pull Starter or
25		Flo-Jet Carburetor	5 - Plain Bearing	Side Pull Starter
26		Electronic or	Gear Reduction	
28		Mechanical Governor	(6 to 1) CW Rotation	
29		5 - Vertical Shaft	Flange Mounting	
30		Vacu-Jet Carburetor	6 - Plain Bearing	
31		Pneumatic or Mechanical	Gear Reduction	
32		Governor	(6 to 1) CCW Rotation	
35		6 - Vertical Shaft	7 - Plain Bearing	
38		7 - Vertical Shaft	Pressure Lubrication on	
40		Flo-Jet Carburetor	Vertical Shaft	
42		Pneumatic or Mechanical	8 - Plain Bearing	
43		Governor	Auxiliary Drive (PTO)	
44		8 - Vertical Shaft	Perpendicular to Crankshaft	
46		Flo-Jet Carburetor	9 - Plain Bearing	
46		Mechanical Governor	Auxiliary Drive	
58		9 - Vertical Shaft	Parallel to Crankshaft	
		Pulsa-Jet Carburetor		
		Pneumatic or Mechanical		
		Governor		

The type number identifies certain unique features such as the crankshaft or governor spring used on an engine.

The code/serial number identifies the assembly date of the engine and serial number. In some instances it is necessary to know the code/serial number as well as the model and type number when performing adjustments, repairs or ordering replacement parts for an engine. Here is how it works.

Example: 950521150

- A. The first two digits, 95, indicate the calendar year, 1995.
- B. The second two digits, 05, indicate the calendar month, May.
- C. The third two digits, 21, indicate the calendar month day.
- D. The last three digits, 150, indicate the serial number.

GENERAL INFORMATION

Maintenance Schedule

More frequent service is required when operating in adverse conditions (note 4 below).

	Maintenance Operation	Daily	Every 50 hours	Every 100 hours	Every 200 hours	Every 600 hours	Yearly
Lubrication System	Check oil level	•					
	Check for oil leaks	•					
	Change oil		• 1		• 2, 4		
	Change oil filter		• 1		• 2, 4		
Cooling System	Check coolant	•					
	Change coolant						•
	Check fan belt			•			
Engine	Service air cleaner		• 1	• 2, 4		• 3, 4	
	Check valve clearance					•	
Electrical System	Check battery electrolyte				•		
	Change spark plugs						•
Fuel System	Change fuel filter					•	

- 1 Perform first maintenance operation after 50 hours.
- 2 Then perform maintenance operation at this interval.
- 3 Replace after every 600 hours of operation.
- 4 Service more often when operating under heavy load or in high temperatures.

Section 2

Cylinder Head and Valves

Section Contents

	Page
REMOVE CYLINDER HEAD	2
DISASSEMBLE CYLINDER HEAD	4
INSPECT AND REPAIR	
Cylinder Head	5
Valve Guides	5
Valves	6
DISASSEMBLE ROCKER ARM SHAFT	7
ASSEMBLE ROCKER ARM SHAFT	8
ASSEMBLE CYLINDER HEAD	9
INSTALL CYLINDER HEAD	10
ADJUST VALVES	13

Overhead Valve Train

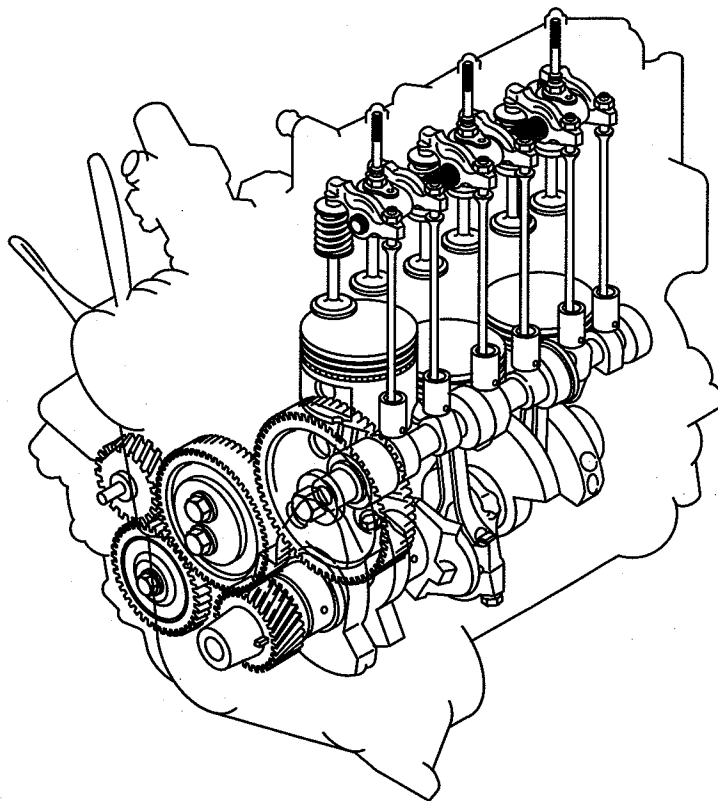

CYLINDER HEAD AND VALVES

REMOVE CYLINDER HEAD

Drain cooling system and disconnect radiator hoses and bypass hose at water pump.

1. Remove the following parts from engine, Fig. 1:

- a. Alternator adjusting bracket screw
- b. V-belt
- c. Fan (if equipped)

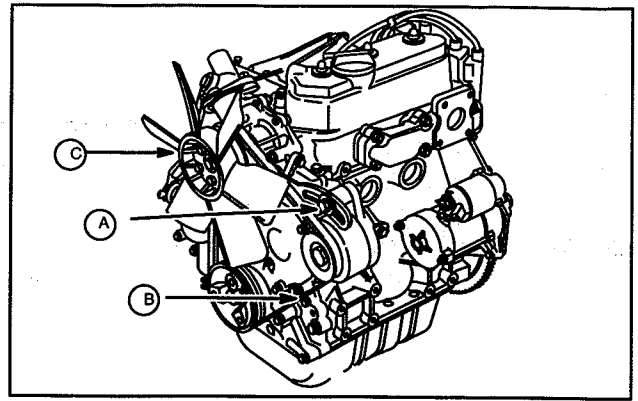

Fig. 1 – Remove V-belt And Fan

- d. Water pump pulley
- e. Water pump
- f. Exhaust manifold

Note: Remove exhaust system before removing exhaust manifold.

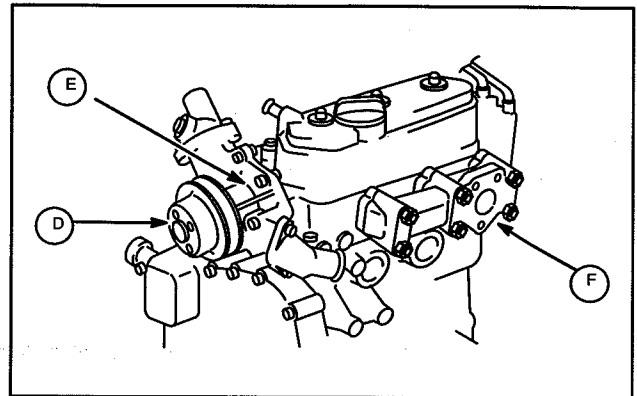

Fig. 2 – Remove Water Pump And Exhaust Manifold

- g. Remove fuel line
- h. Governor link and spring
- i. Intake manifold
- j. Remove spark plug wires and spark plugs

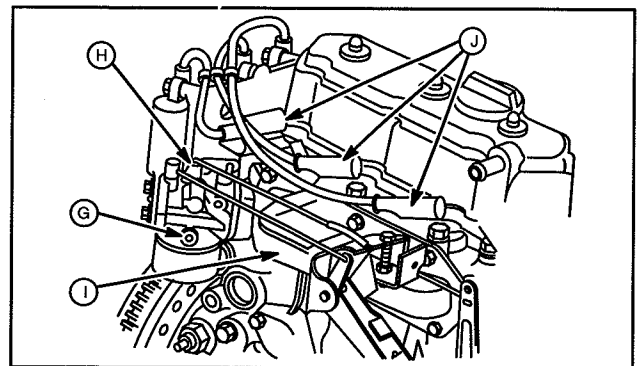

Fig. 3 – Remove Intake Manifold

2. Remove the following parts, Fig. 4:

- a. Ignition coil bracket and ignition coils.

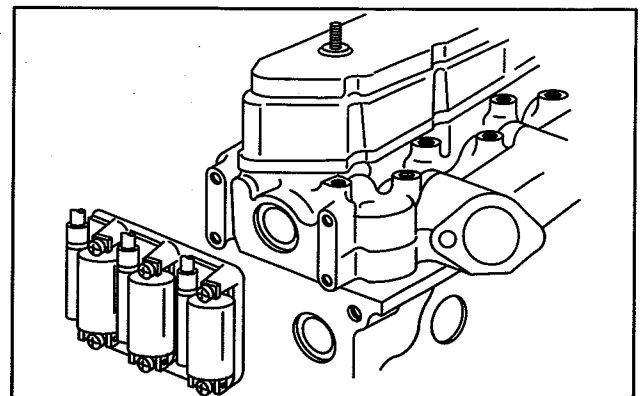

Fig. 4 – Remove Ignition Coil Bracket

CYLINDER HEAD AND VALVES

3. Remove valve cover, Fig. 5.

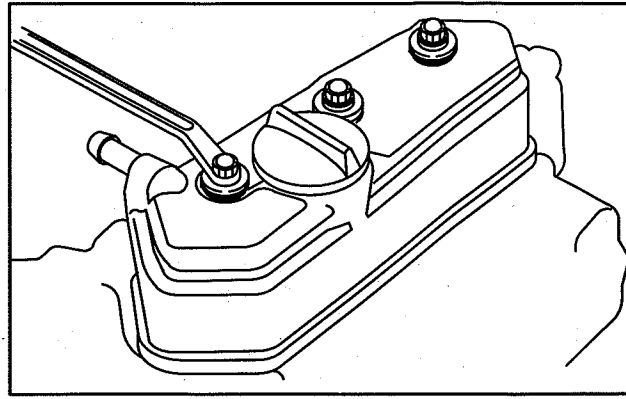

Fig. 5 – Remove Valve Cover

4. Set No. 1 piston at TDC:

- Rotate crankshaft pulley until timing mark on pulley is aligned with reference point on timing cover.
- If intake and exhaust valves have clearance, No. 1 piston is at TDC – compression stroke.
- If intake and exhaust valves do not have clearance, turn crankshaft pulley one complete revolution. Valves will then have clearance.

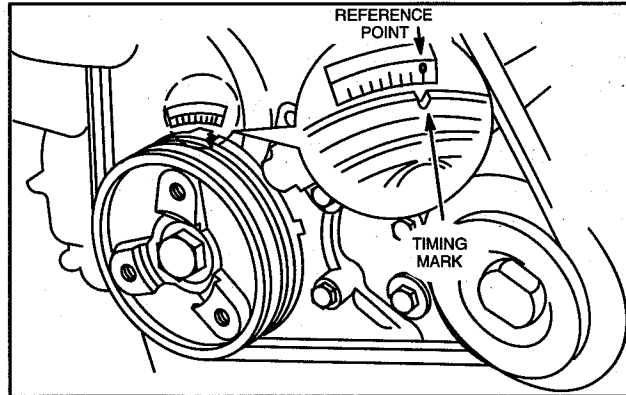

Fig. 6 – Set Cylinder No. 1 at TDC

5. Remove rocker arm assembly and push rods, Fig. 7.

- Remove valve stem caps.

Note: Mark push rods so that they may be reassembled in their original position.

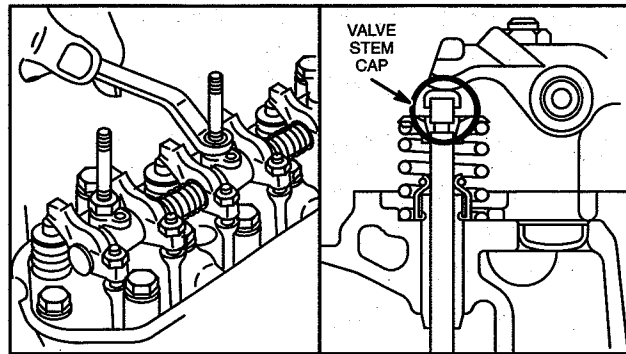

Fig. 7 – Remove Rocker Arm Assembly And Push Rods

6. Remove cylinder head assembly, Fig. 8.

- Loosen cylinder head bolts in the order shown.

Note: Current style head bolts are 9 mm diameter. Early style head bolts are 8 mm diameter. Torque specifications are different.

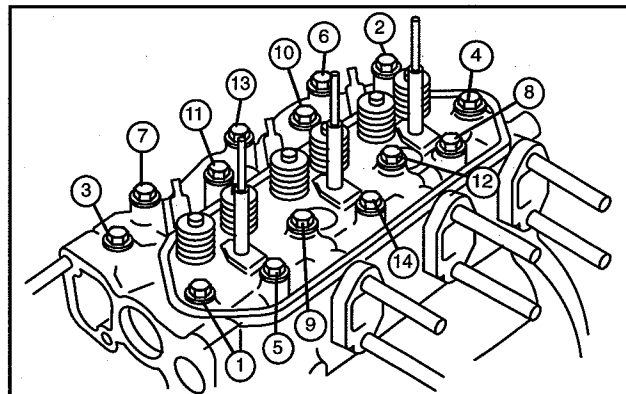

Fig. 8 – Loosen Cylinder Head Bolts

CYLINDER HEAD AND VALVES

4. Using bushing driver, Tool #19416, press in new valve guide bushing until tool bottoms on cylinder head, Fig. 16.

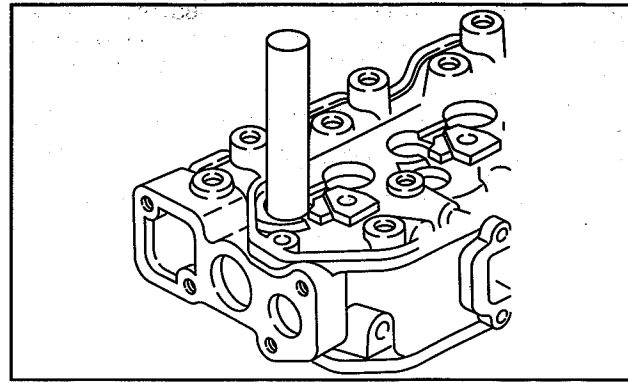

Fig. 16 – Installing Valve Guide Bushing

5. Valve faces may be resurfaced to 30°. See Fig. 17 for dimensions for valves. Lap valves and seats with valve lapping tool, #19258 and valve lapping compound, tool #94150.

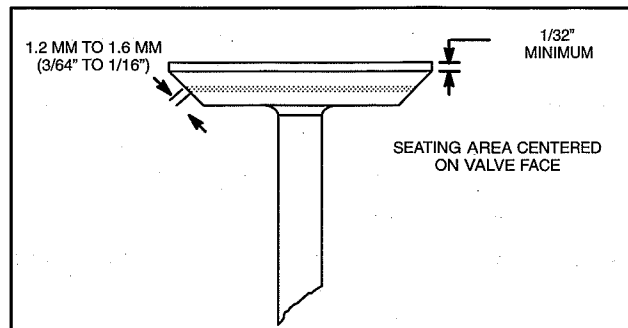

Fig. 17 – Valve Dimensions

6. Valve seats may be reconditioned using valve seat cutter tool #19446.

Note: Check valve guide bushings first. If valve guides are worn, they must be replaced before refacing valve seats

If valve seat is wider than dimension shown in Fig. 18, a narrowing cutter should be used to ensure that contact area of valve seat is centered on face of valve.

- a. Use a 45° cutter to narrow seat from bottom and a 15° cutter to narrow seat from top, Fig. 18.

Note: If valve seat is loose or cracked, replace cylinder head.

7. Measure valve stem diameter at specified distance from end of valve, as shown in Fig. 19.

Replace IN if less than 5.952 mm (0.2343 in).

Replace EX if less than 5.948 mm (0.2342 in).

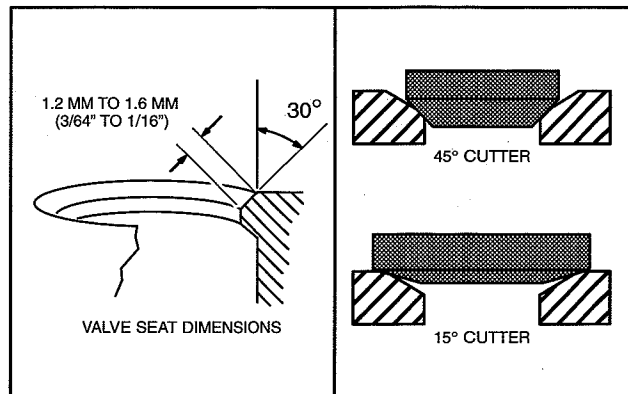

Fig. 18 – Valve Seat Dimensions

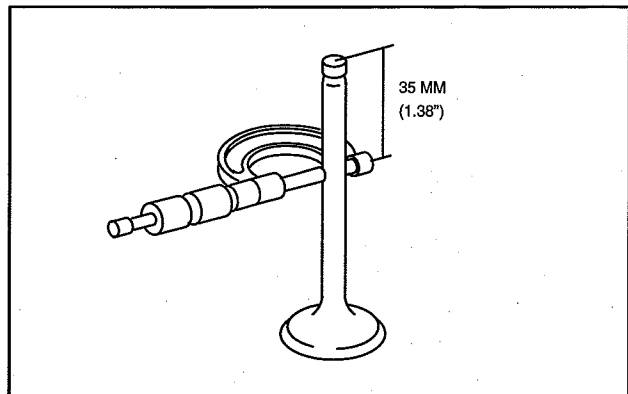

Fig. 19 – Measure Valve Stem Diameter

8. Inspect valve stem cap for wear, Fig. 20.

Replace if cap is worn recessed.

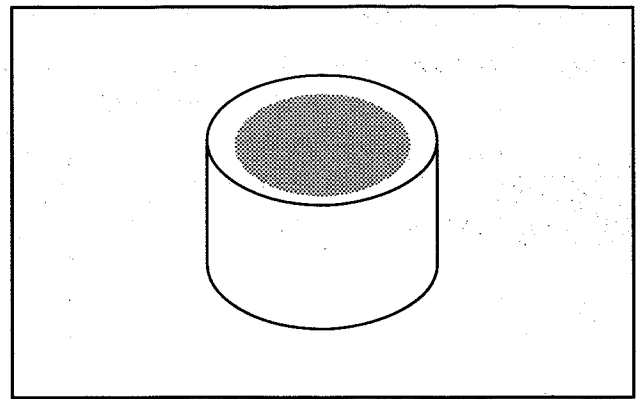

Fig. 20 – Check Valve Stem Cap

9. Check valve springs for squareness and free length, Fig. 21.

Replace if out of square more than 1.0 mm (.040 in).

Replace if free length is less than 29.2 mm (1.150 in).

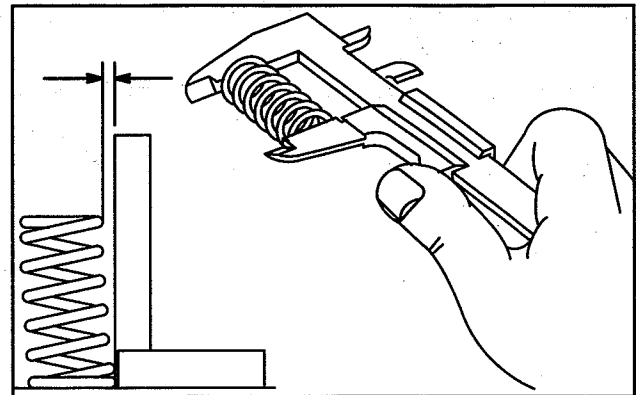

Fig. 21 – Check Valve Springs

DISASSEMBLE ROCKER ARM SHAFT

Remove snap rings from ends of rocker arm shaft. Remove set screw from center rocker arm support. Disassemble rocker arm assembly. Note position of all components, Fig. 22.

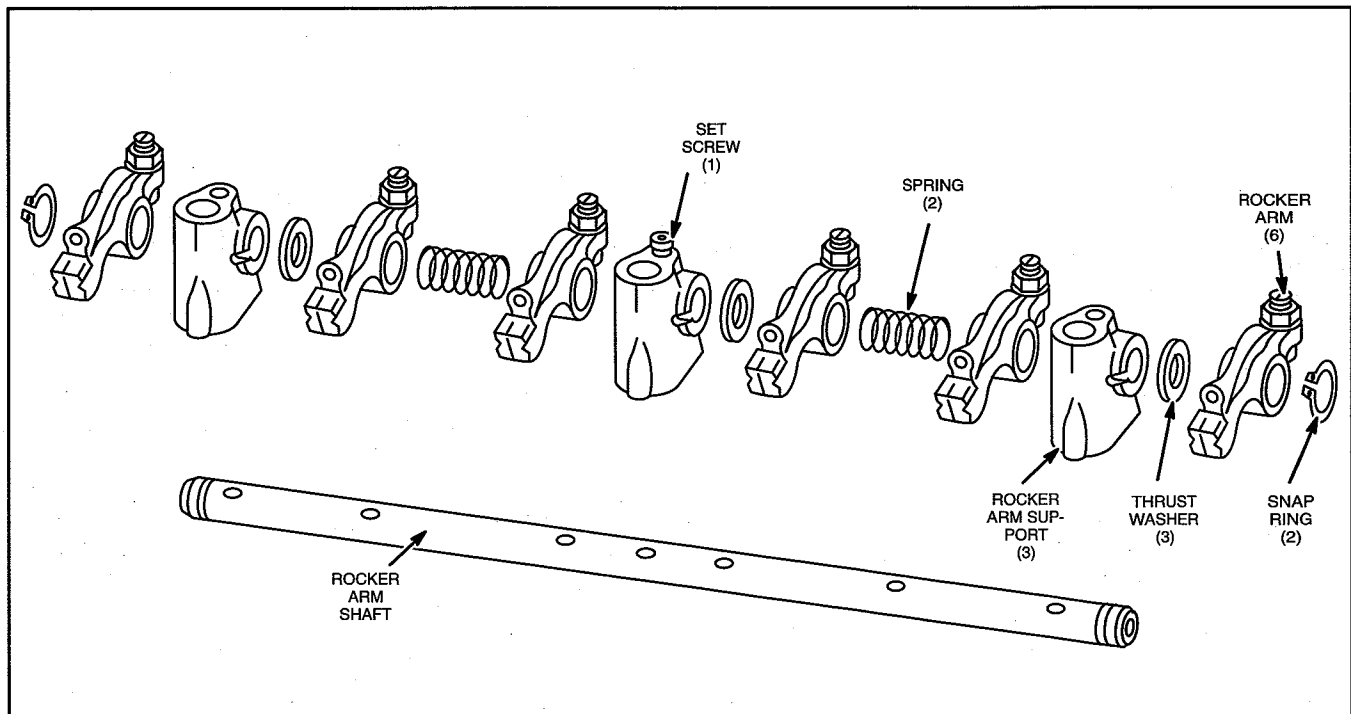

Fig. 22 – Rocker Arm Components

CYLINDER HEAD AND VALVES

10. Check rocker arms and shaft

- a. Check rocker arm-bearing.

Replace if greater than 10.03 mm (0.395").

- b. Check rocker arm shaft.

Replace if less than 9.957 mm (0.392").

- c. Check rocker arm studs for stripped threads and replace if required.

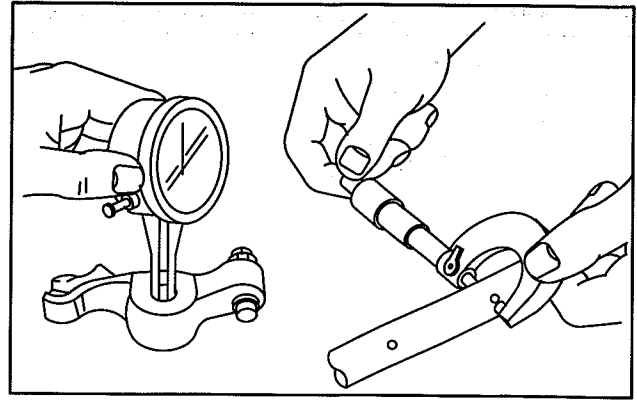

Fig. 23 – Checking Rocker Arm And Shaft

2

ASSEMBLE ROCKER ARM SHAFT

1. Oil all components before assembling. Small grooves in rocker shaft next to oil holes must face down. Assemble rocker arm components, noting order of assembly as shown in Fig. 24. Note position of three thrust washers. Install set screw in center rocker arm shaft support.

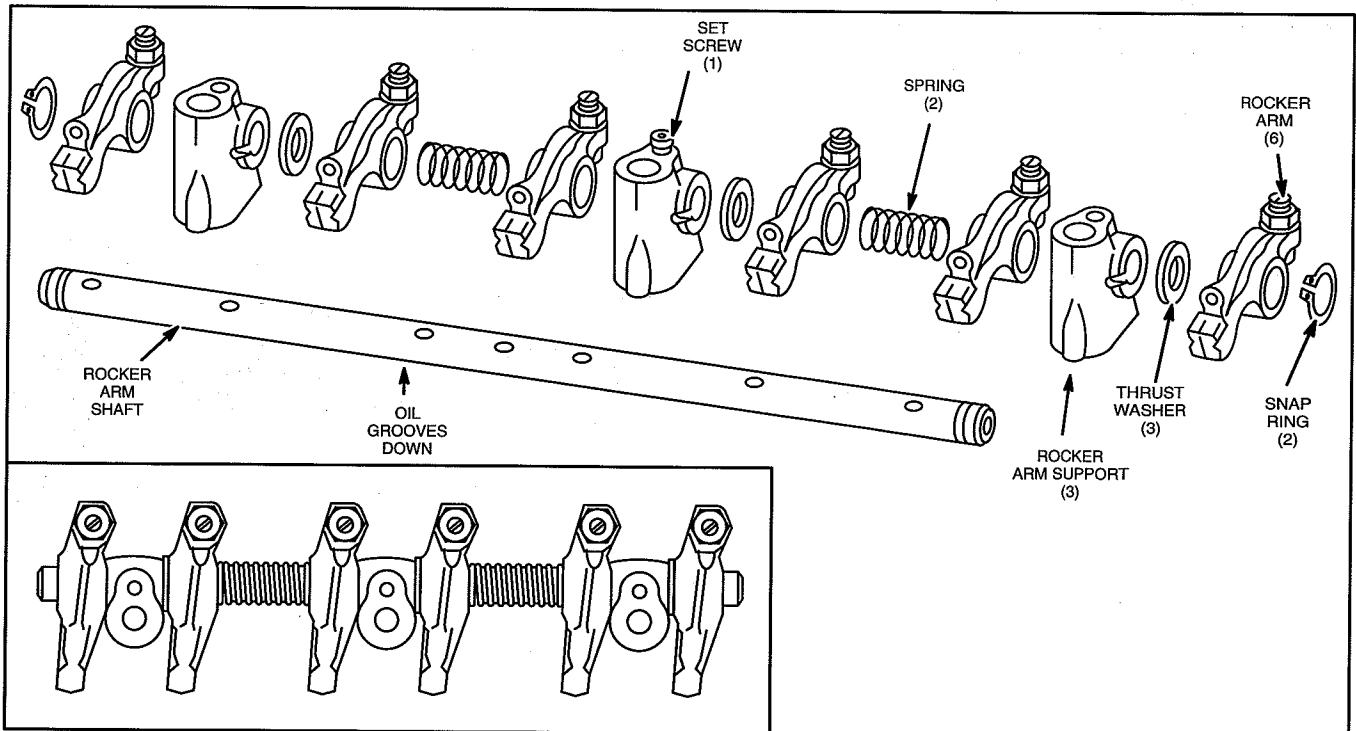

Fig. 24 – Rocker Arm Components

ASSEMBLE CYLINDER HEAD

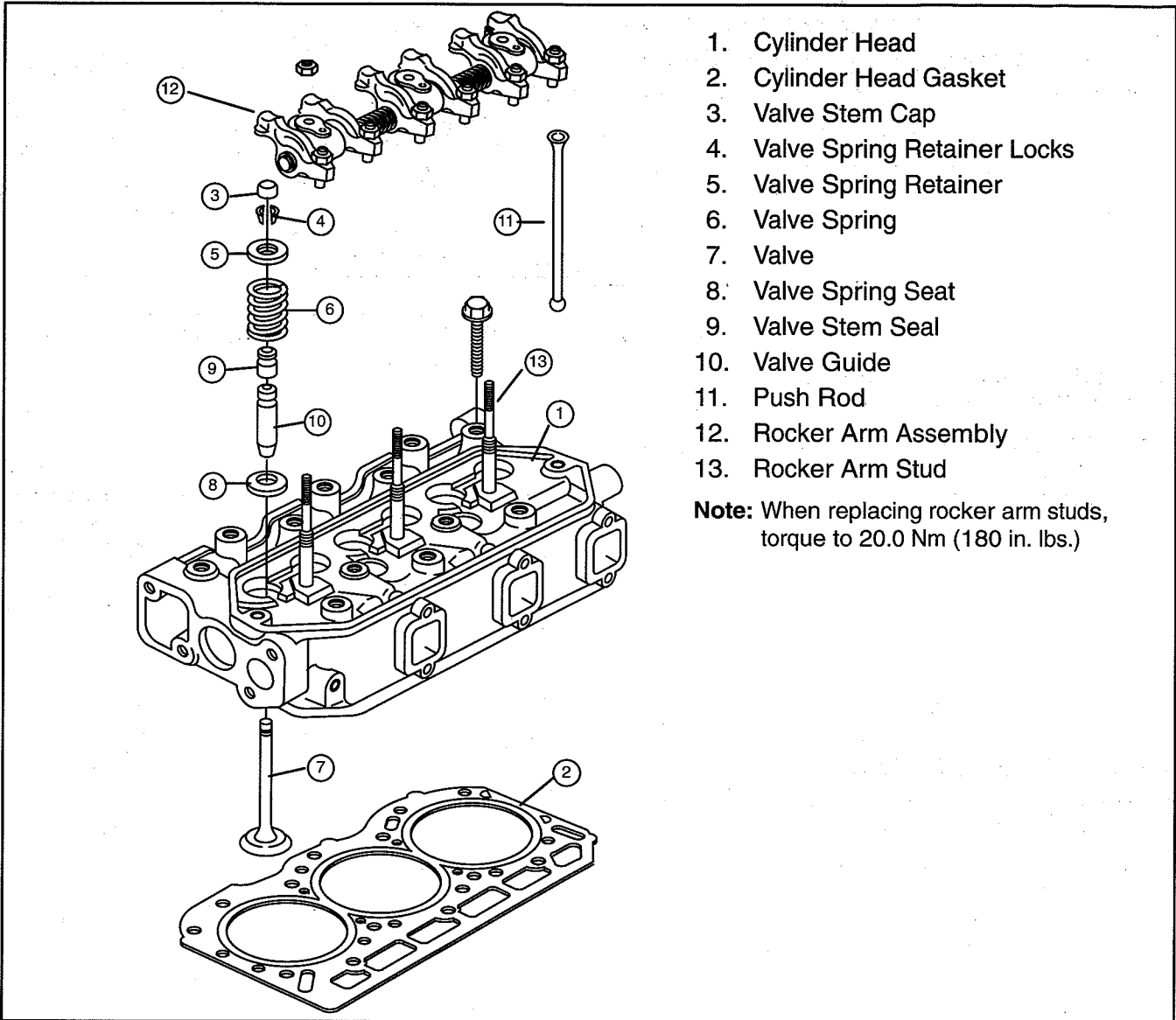

Fig. 25 – Cylinder Head Components

1. Install new valve stem seals, Fig. 26. Oil inner surface and lip of seal before installing. Press seal on to valve guide bushing until it bottoms.

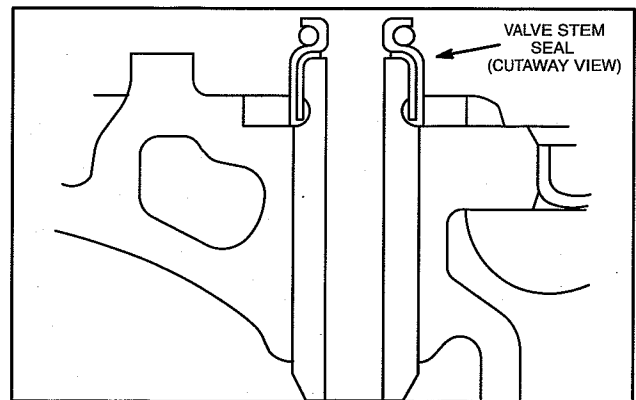

Fig. 26 – Install Valve Stem Seals

CYLINDER HEAD AND VALVES

2. Install valve spring seats, Fig. 27.

Note: Lightly coat valve stems with Valve Guide Lubricant #93963 before installing valves.

3. Install valves.

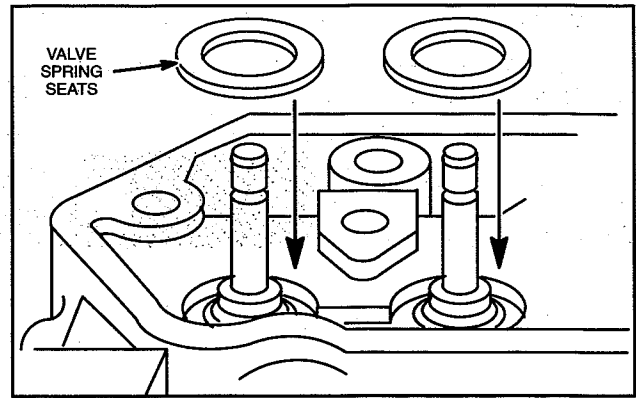

Fig. 27 – Install Valve Spring Seats And Valves

4. Install valve springs with valve spring compressor, Tool #19417, Fig. 28.

Note: After installing valve spring retainer locks, tap valve spring retainer lightly with a soft hammer to ensure locks are seated.

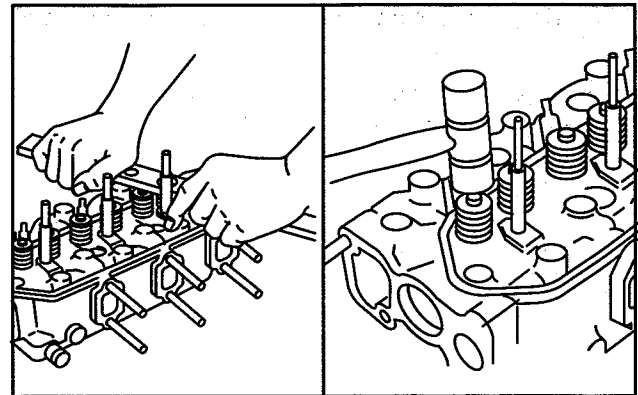

Fig. 28 – Install Valve Springs

INSTALL CYLINDER HEAD

1. Place cylinder head gasket over alignment dowels on cylinder block, Fig. 29.

Note: Make sure coolant, oil passages and head bolt holes are aligned.

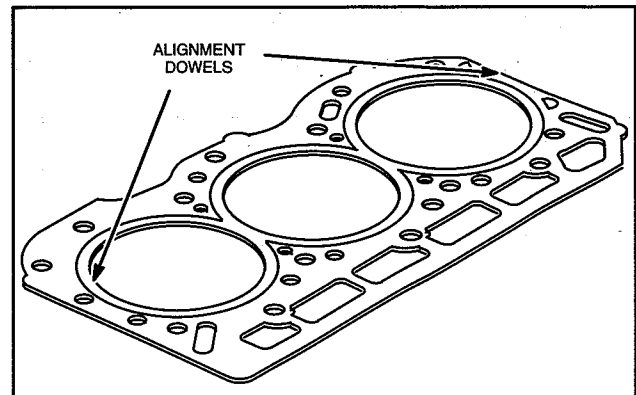

Fig. 29 – Install Cylinder Head Gasket

2. Install cylinder head assembly, Fig. 30. Lubricate threads of cylinder head bolts with engine oil. Torque head bolts in 13.0 Nm (10 ft. lbs.) increments in sequence shown.

Note: Current style head bolts are 9 mm diameter. Early style head bolts are 8 mm diameter. Torque specifications are different.

- a. Torque 9 mm head bolts to 35.0 Nm (26 ft. lb.).
 - b. Torque 8 mm head bolts to 34.0 Nm (25 ft. lb.).
3. Lubricate push rods with engine oil then install with recessed end up, Fig. 30.

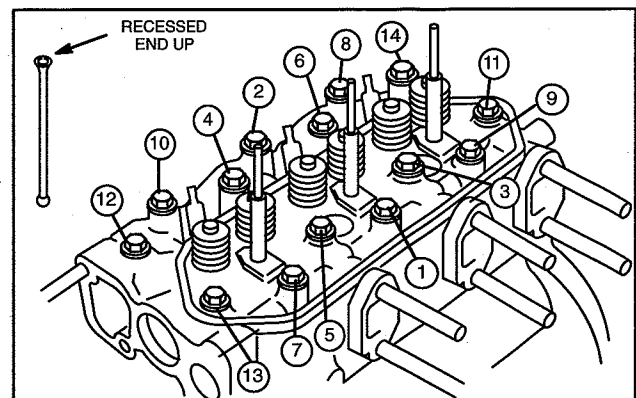

Fig. 30 – Install Cylinder Head Assembly

4. Install valve stem caps on valve stems. Install rocker arm assembly, Fig. 31. Install washers and torque nuts to 19.0 Nm (170 in. lbs.).

Note: Make sure rocker adjustment studs are seated in recessed end of push rods.

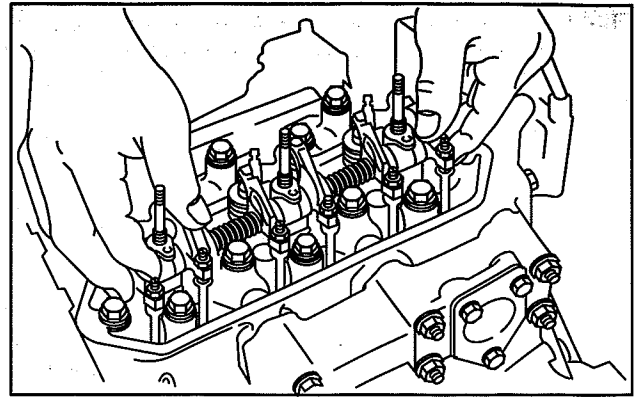

Fig. 31 – Install Rocker Arm Assembly

5. Install ignition coil bracket and ignition coils.
 - a. Torque screws to 20.3 Nm (180 in. lbs.)

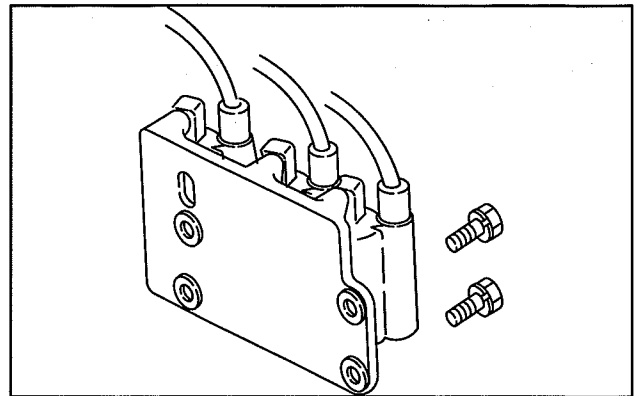

Fig. 32 – Install Ignition Coil Bracket And Ignition Coils

6. Install intake manifold with new gasket. Install governor link and spring, Fig. 34.
 - a. Torque screws to 7.0 Nm (60 in. lbs.)

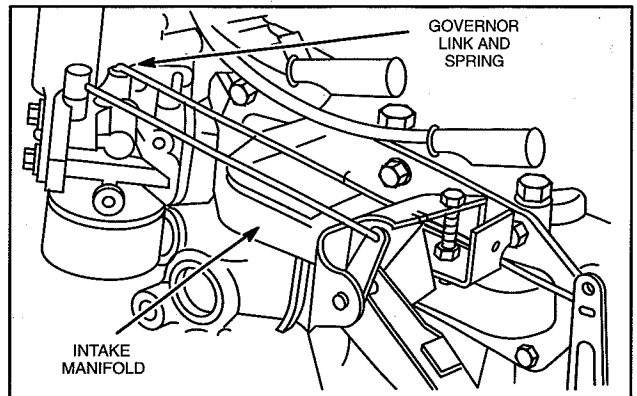

Fig. 33 – Install Intake Manifold And Governor Link

7. Insert governor spring into original hole in governor lever.

Note: Normal spring position is in center hole in governor lever, all models, Fig. 34.

Important: Governor spring must be installed in correct hole in governor control lever by engine model, Fig. 34.

- a. Model 430400 – Top Hole
- b. Model 580400 – Bottom Hole

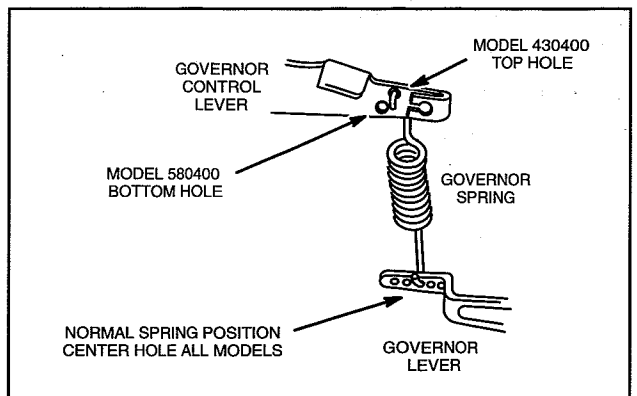

Fig. 34 – Governor Spring Position

CYLINDER HEAD AND VALVES

8. Install exhaust manifold with new gasket, Fig. 35.
 - a. Torque screws to 19.0 Nm (170 in. lbs.).

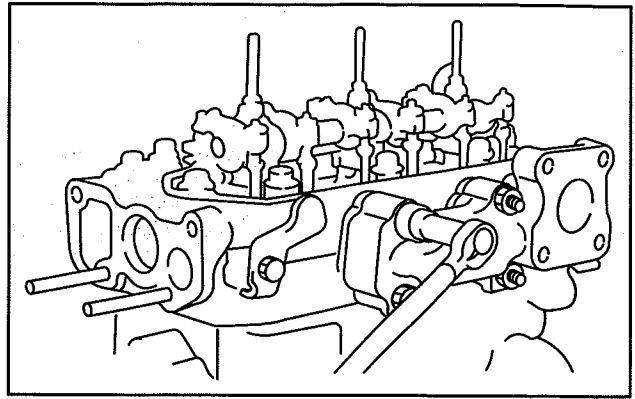

Fig. 35 – Install Exhaust Manifold

9. Install water pump with new gasket, Fig. 36.
 - a. Torque screws and nuts to 19.0 Nm (170 in. lbs.).

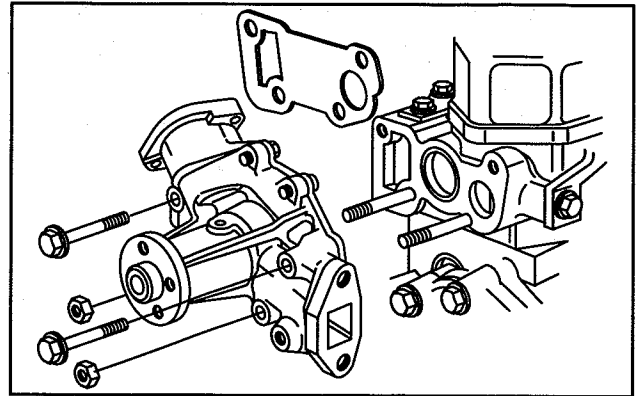

Fig. 36 – Install Water Pump

10. Install water pump pulley, Fig. 37.
11. Install fan (if equipped).
 - a. Torque screws to 7.0 Nm (60 in. lbs.).

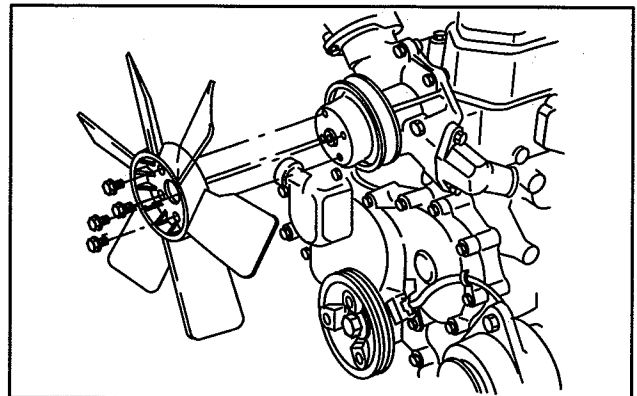

Fig. 37 – Install Water Pump Pulley And Fan

12. Install V-belt, Fig. 38.
13. Install alternator adjusting bolt.
 - a. Torque bolt to 19.0 Nm (170 in. lbs.).

Belt deflection limit is 10.0-12.0 mm/10 kg (3/8-1/2 in/22 lb).

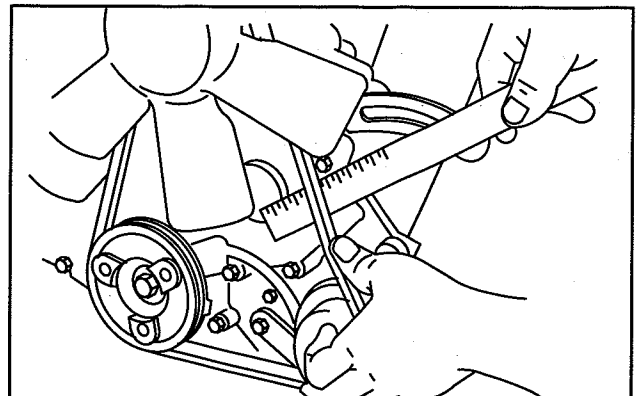

Fig. 38 – Adjusting V-belt

ADJUST VALVES

1. Before adjusting valves, make sure that No. 1 cylinder is at TDC – compression stroke, Fig. 39.

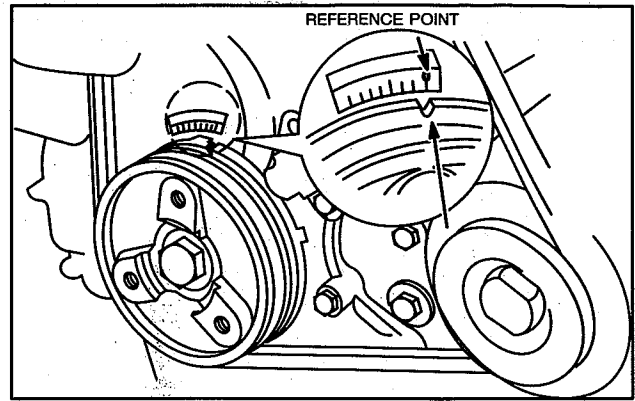

Fig. 39 – Set Cylinder No. 1 at TDC

a. Adjust valves and check, Fig. 40.

Valve Clearance (cold) IN and EX 0.18 mm (0.007 in.)

b. Torque adjusting screws and jam nuts to 11.0 Nm (95 in. lbs.).

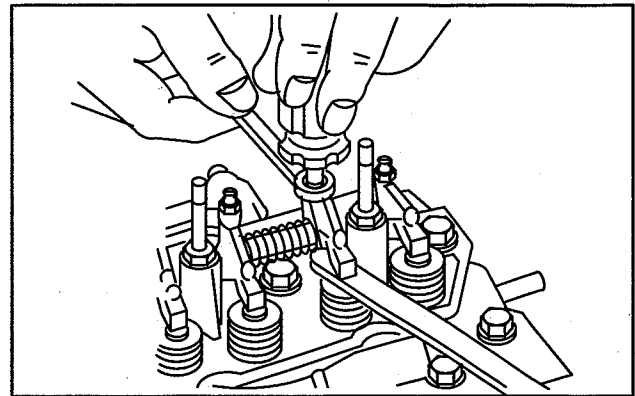

Fig. 40 – Adjust Valve Clearances

With No. 1 piston at TDC of compression stroke, check and adjust valve clearances for cylinders shown in chart at right.

Rotate crankshaft one complete turn (360°) clockwise to check and adjust remaining valves.

Piston Position	Cylinder	1	2	3
No. 1 piston at TDC, of compression stroke	IN	●		●
	EX	●	●	
Rotate Crankshaft 360° clockwise	IN		●	
	EX			●

2. Install valve cover, Fig. 41.

a. Torque cover nuts to 6.0 Nm (50 in. lbs.).

3. Install spark plugs.

a. Torque spark plugs to 18.0 Nm (160 in. lbs.).

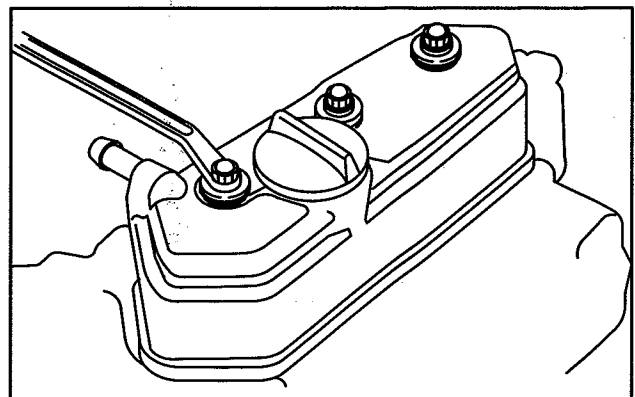

Fig. 41 – Install Valve Cover

Dear Mr. [Name],

I have received your letter of the 15th and am glad to hear from you.

I am sorry that I cannot give you a more definite answer at this time.

I will be in touch with you again as soon as I have more information.

Very truly yours,

[Signature]

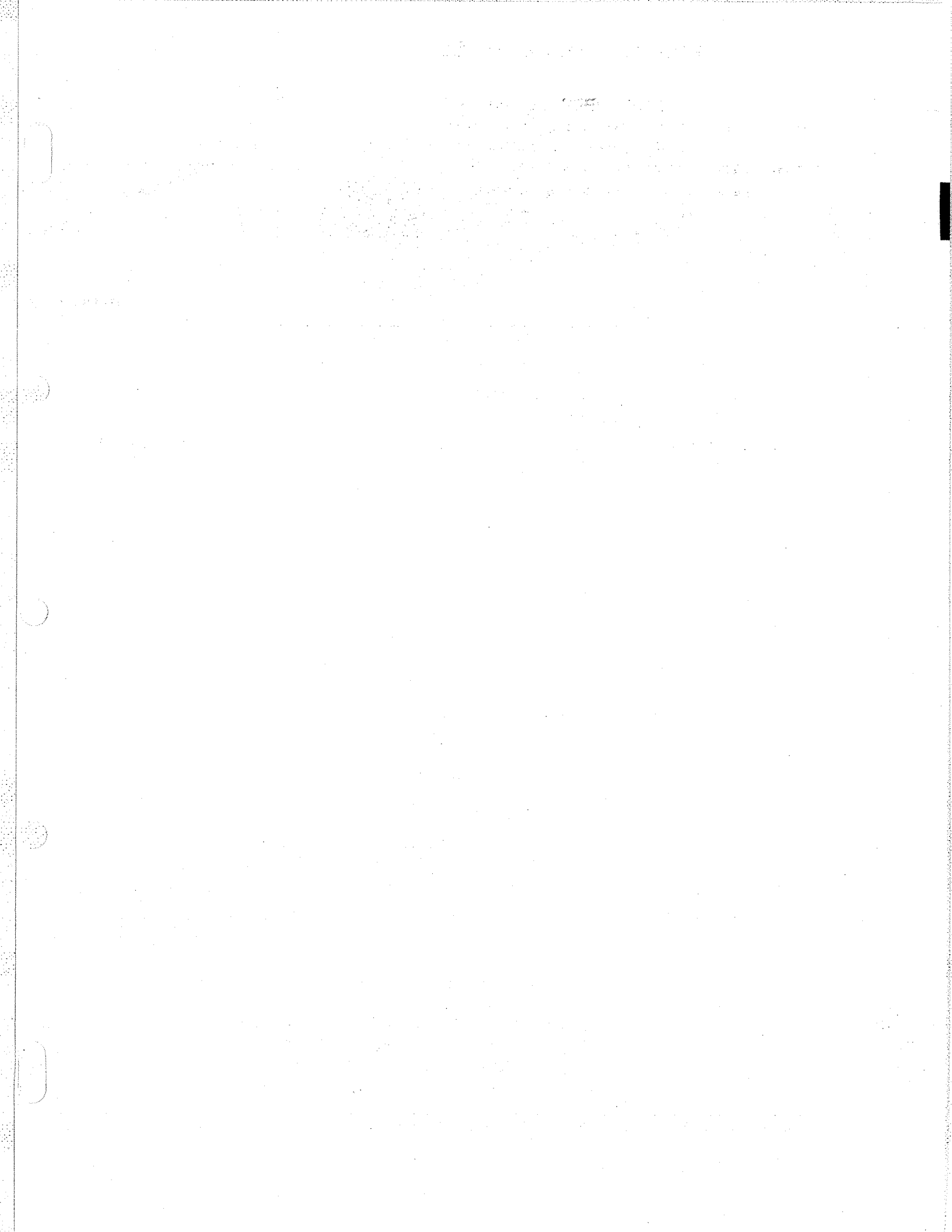

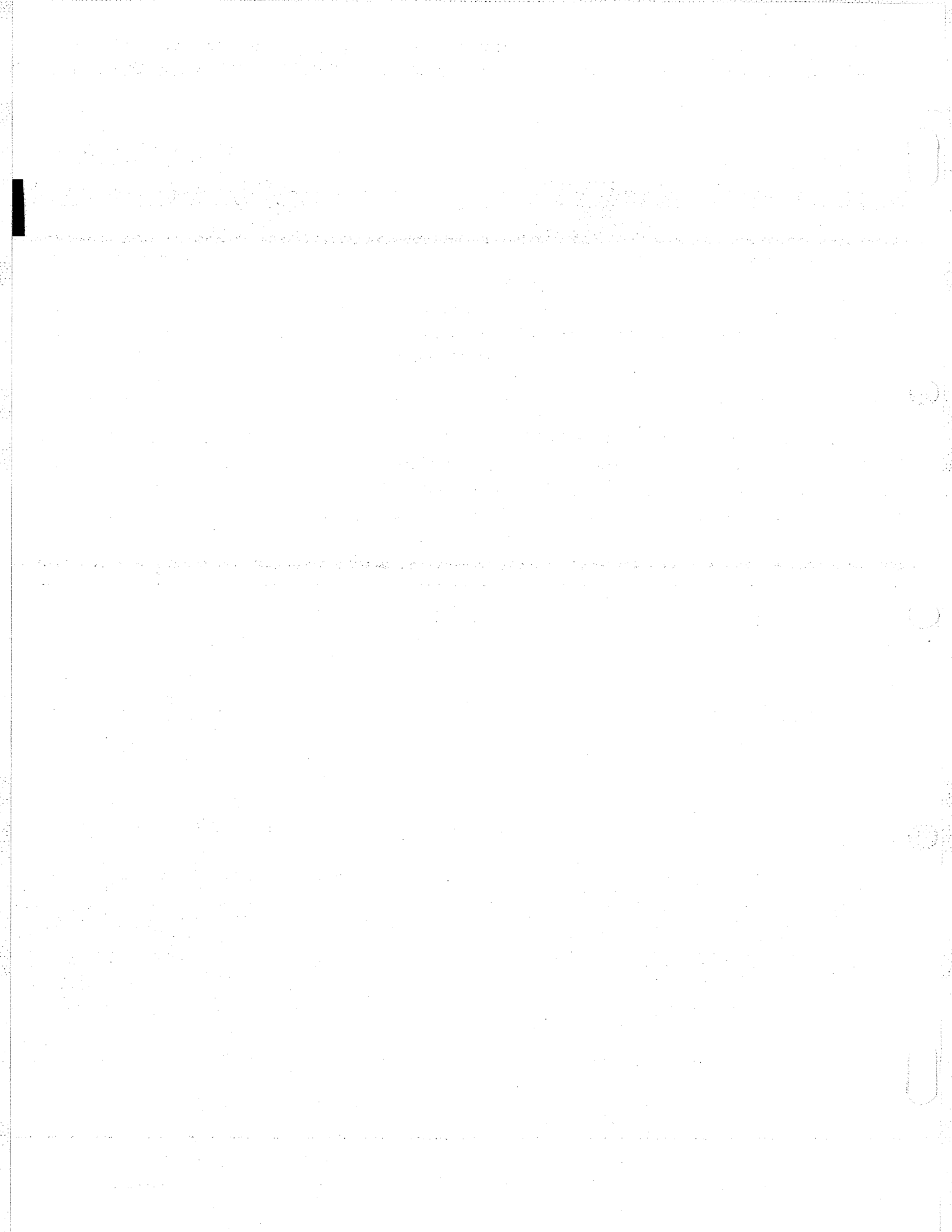

Section 3

Mechanical Governor/Timing Gears & Gear Case Electronic Governor

Section Contents

	Page
REMOVE TIMING GEAR COVER AND GEARS	2
CHECKING GEARS	3
REMOVE GEAR CASE	4
DISASSEMBLE GOVERNOR SHAFT	4
REPLACE TIMING GEAR COVER OIL SEAL	4
ASSEMBLE GOVERNOR	5
ASSEMBLE TIMING GEAR CASE AND GEARS	5
ADJUST GOVERNOR	8
TROUBLESHOOTING	8
ELECTRONIC GOVERNOR	9
CHECKING GOVERNOR ACTUATOR	9
REMOVE GOVERNOR ACTUATOR	10
INSTALL GOVERNOR ACTUATOR	10

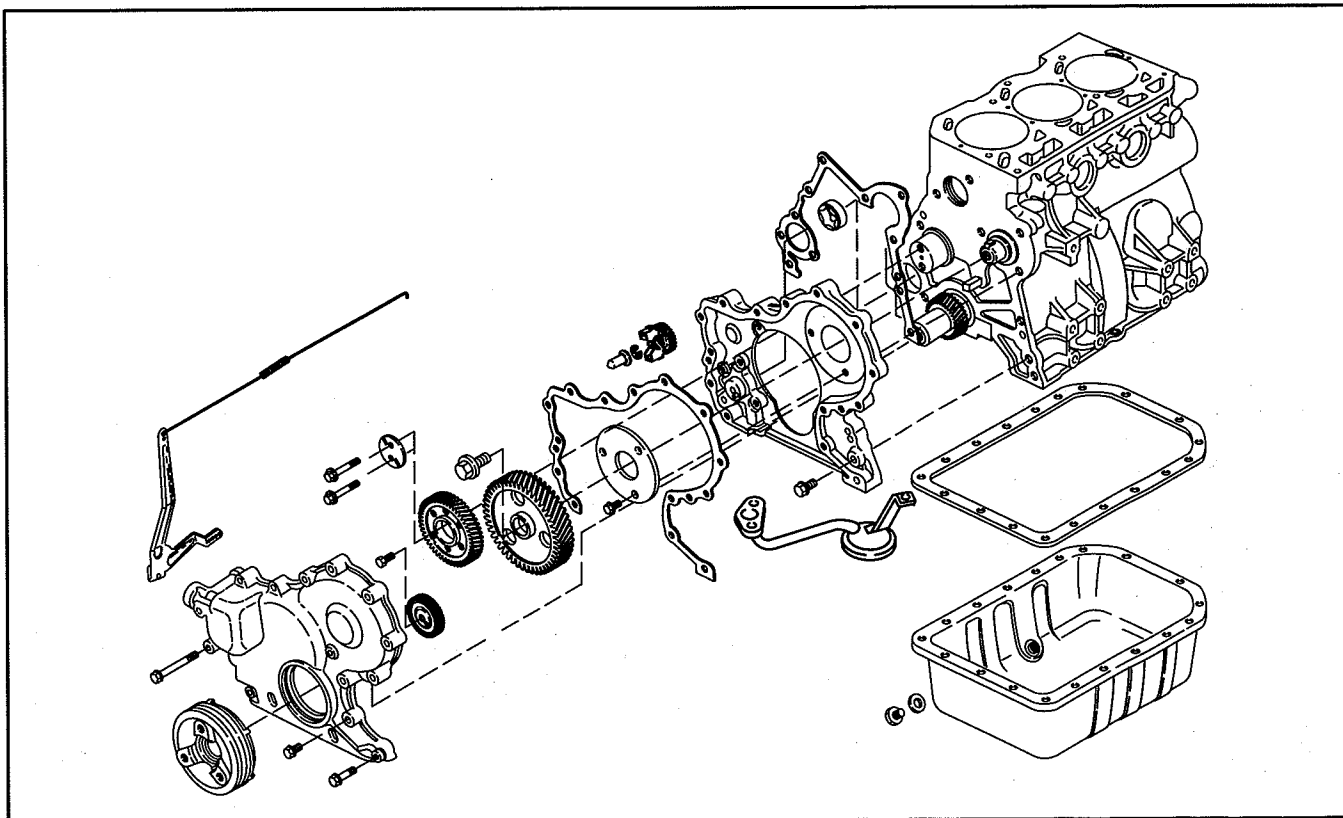

GOVERNOR, TIMING GEARS AND GEAR CASE

REMOVING TIMING GEAR COVER AND GEARS

Make sure that #1 cylinder is at TDC, compression stroke. See Section 2.

Remove V-belt and fan (if equipped). Drain oil from engine.

Note: Before removing governor spring, note hole position of governor spring in governor lever.

1. Remove the following parts.
 - a. Remove governor link spring, and governor link from carburetor.
 - b. Remove governor spring from governor lever.
 - c. Loosen nut and remove governor lever from governor shaft, Fig. 1.
2. Remove oil pan screws and nuts, Fig. 2.
 - a. Remove oil pan and discard gasket.
 - b. Remove oil pick-up tube and strainer. Discard gasket.

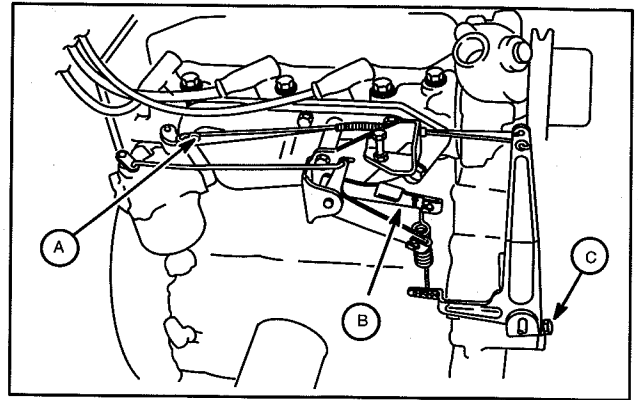

Fig. 1 – Remove Governor Lever

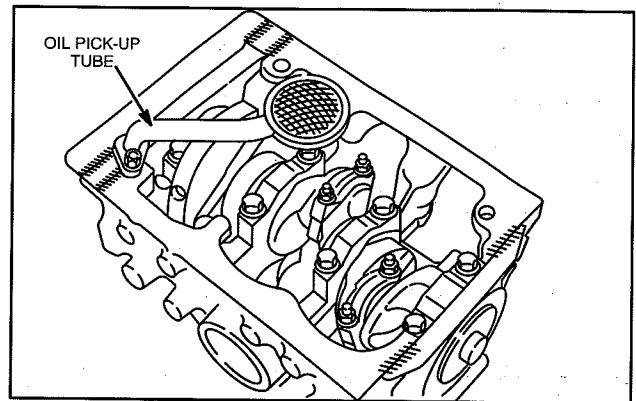

Fig. 2 – Removing Oil Pan

3. Remove bell housing adapter screw if equipped and install flywheel holder, Tool #19418.

LEAVE TOOL INSTALLED.

- a. Remove crankshaft pulley using Tool #19420, Fig. 3.

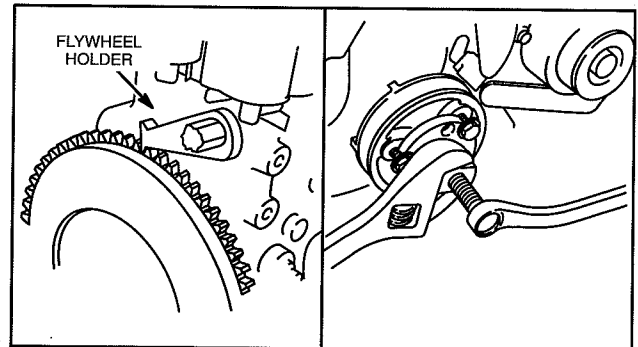

Fig. 3 – Removing Crankshaft Pulley

4. Remove trigger and wire. Remove timing gear cover, Fig. 4.

- a. Discard timing gear cover gasket.

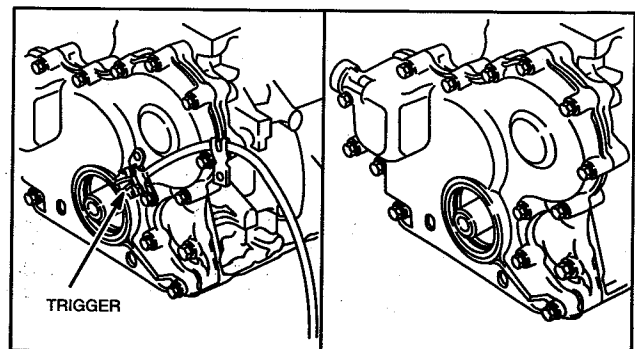

Fig. 4 – Removing Timing Gear Cover

5. Remove governor gear, Fig. 5.
 - a. Governor cup
 - b. E-ring
 - c. Governor gear
 - d. Thrust washer

6. Remove oil pump drive gear.

Check governor gear and oil pump drive gear for damaged teeth.

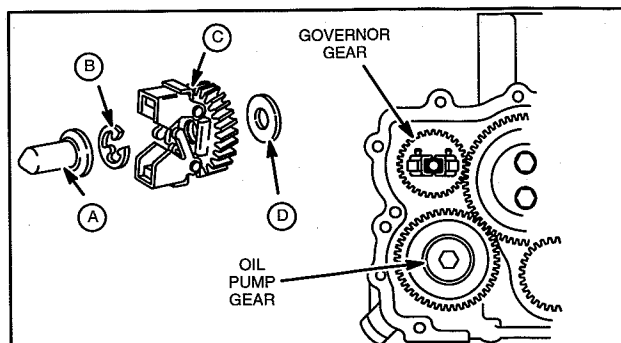

Fig. 5 - Removing Governor Gear

CHECKING GEARS

Inspect gear teeth for wear or damage. CHECK GEARS IN SEQUENCE SHOWN.

1. Check gear backlash between idler gear and crankshaft gear using dial indicator as shown in Fig. 6.
 - a. Set tip of indicator on gear tooth, then rock idler gear back and forth noting indicator reading.

Note: Crankshaft must not turn while checking.

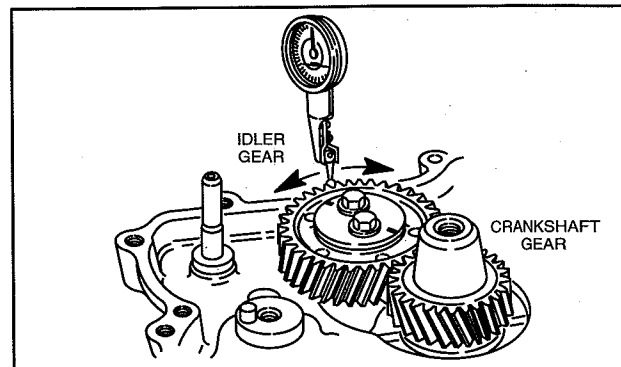

Fig. 6 - Checking Idler Gear Backlash

2. If backlash exceeds 0.2 mm (.008") check idler gear bearing and shaft for wear, Fig. 7.

Reject Dimension: Idler Gear ID -
34.17 mm (1.345")

Idler Gear Shaft OD -
33.91 mm (1.335")

- a. If idler gear bearing and shaft are within specification, replace with new idler gear and re-check.
- b. If backlash exceeds 0.2 mm (.008") with NEW idler gear, crankshaft gear is worn.

Note: If crankshaft gear is worn the crankshaft must be replaced.

3. Hold idler gear as shown and check gear backlash between camshaft timing gear and idler gear using dial indicator, Fig. 8.

Camshaft timing gear backlash must not exceed 0.2 mm (.008").

Note: Idler gear must not turn while checking.

If gears are worn it is recommended that they be replaced as a set.

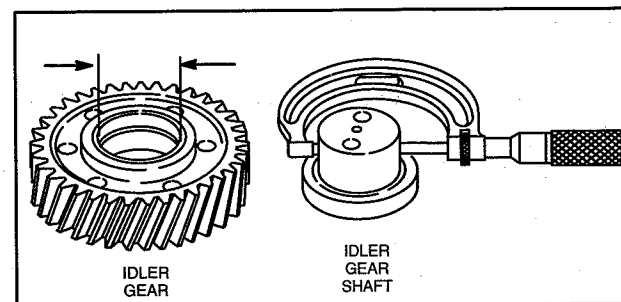

Fig. 7 - Checking Idler Gear And Shaft

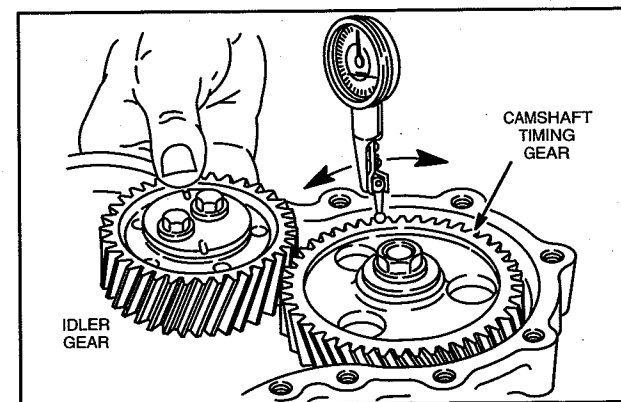

Fig. 8 - Checking Camshaft Timing Gear Backlash

GOVERNOR, TIMING GEARS AND GEAR CASE

REMOVE GEAR CASE

1. Remove parts in sequence shown, Fig. 9.
 - a. Remove 3 screws and camshaft retainer.
 - b. Remove remaining 5 screws.

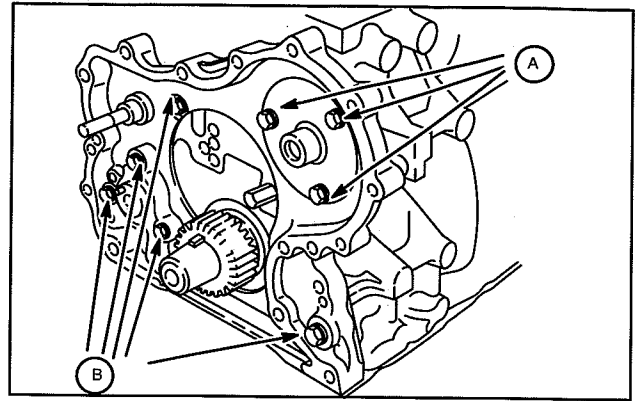

Fig. 9 – Removing Timing Gear Case

2. Remove timing gear case and discard gasket, Fig. 10.
 - a. Remove oil pump rotor from cylinder block.

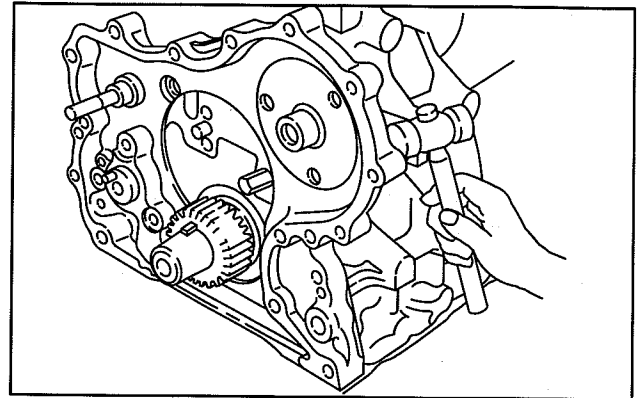

Fig. 10 – Removing Timing Gear Case

DISASSEMBLE GOVERNOR SHAFT ASSEMBLY

1. Remove governor shaft, Fig. 11.
 - a. Remove cotter pin and washer. Discard cotter pin.
 - b. Remove screws and governor paddle using Torx® driver, Tool # 19445. Discard screws.

Note: Governor paddle screws are Torx® tamper proof screws.

 - c. Remove shaft and spacer.
 - d. Remove and discard oil seal.

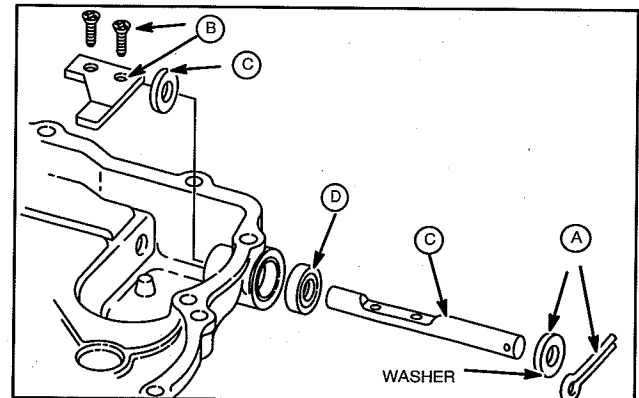

Fig. 11 – Remove Governor Shaft

REPLACE TIMING GEAR COVER OIL SEAL

1. Drive out oil seal.
2. Use seal driver, Tool #19423 to install new oil seal, Fig. 12.

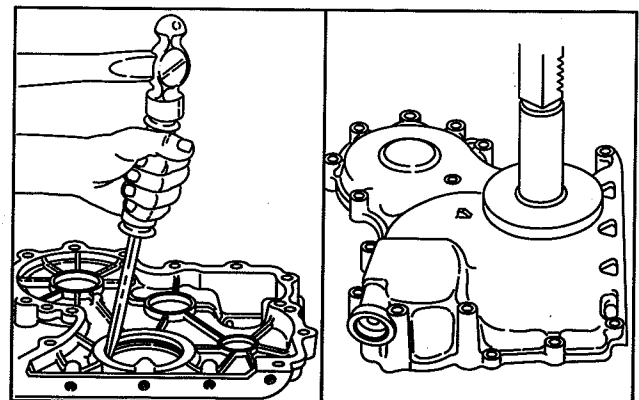

Fig. 12 – Replacing Oil Seal

ASSEMBLE GOVERNOR ASSEMBLY

1. Assemble governor gear to shaft, Fig. 13.
 - a. Thrust washer
 - b. Governor gear
 - c. E-ring
 - d. Governor cup

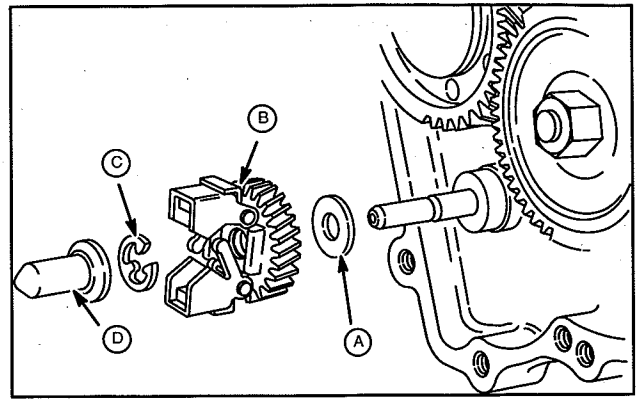

Fig. 13 – Installing Governor Gear

Lubricate governor shaft with engine oil before installing.

2. Assemble governor shaft, Fig. 14.
 - a. Install new oil seal with seal lips in.
 - b. Install governor shaft and spacer.
 - c. Install governor paddle.
 - d. Install new screws using Torx® driver, Tool #19445.
 - e. Torque to 0.9 Nm (8 in. lbs.).
 - f. Install washer and new cotter pin

Note: Governor shaft must rotate freely.

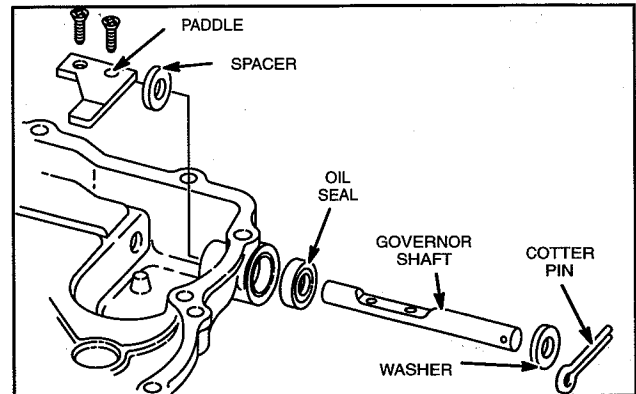

Fig. 14 – Installing Governor Shaft

ASSEMBLE TIMING GEAR CASE AND GEARS

1. Clean and lubricate oil pump rotor with engine oil and install in cylinder block, Fig. 15.
 - a. ID mark on rotor must face cylinder block.

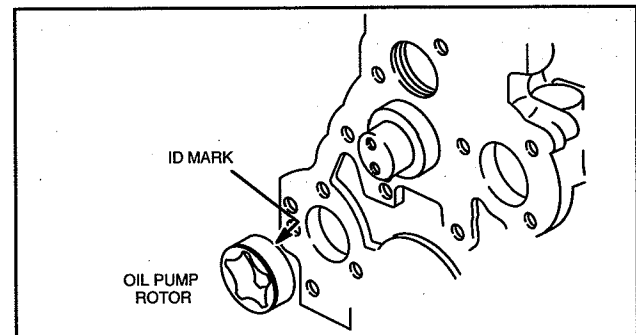

Fig. 15 – Installing Oil Pump Rotor

2. Install timing gear case with new gasket. Install camshaft retainer, Fig. 16.

Note: It may be necessary to rotate oil pump drive to engage oil pump rotors.

Note: Position camshaft retainer so that center hole does not interfere with camshaft.

Note position, length and number of screws as shown.

- a. M6 x 28 mm (M6 x 1.1"): 4
- b. M6 x 18 mm (M6 x 0.7"): 3
- c. M6 x 16 mm (M6 x 0.6"): 1

Torque screws to 8.0 Nm (70 in. lbs.).

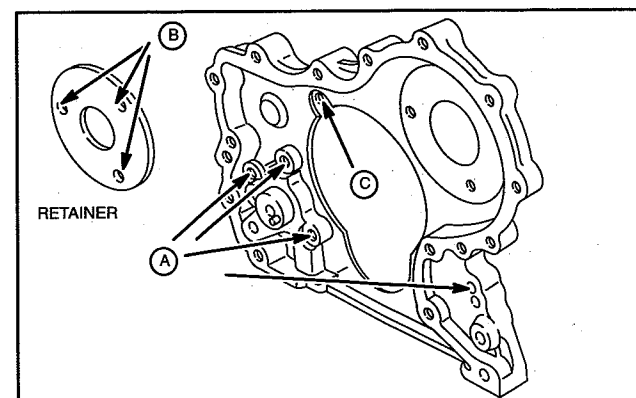

Fig. 16 – Installing Timing Gear Case

GOVERNOR, TIMING GEARS AND GEAR CASE

3. Make sure crankshaft key is at 12 o'clock position as shown in Fig. 17.

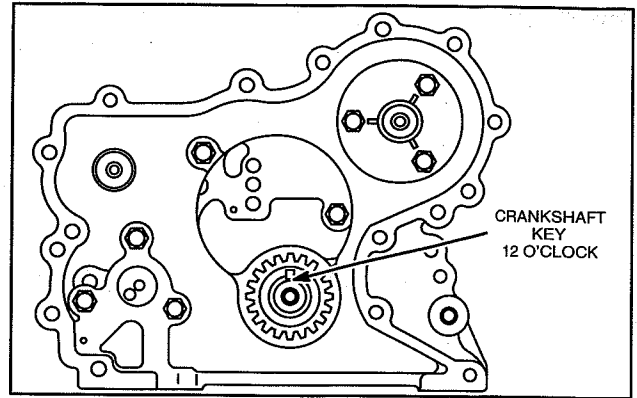

Fig. 17 - Crankshaft Position

4. Assemble idler gear shaft with arrow up, as shown in Fig. 18.

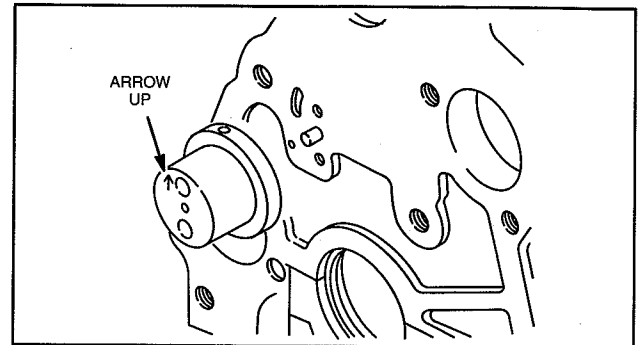

Fig. 18 - Installing Idler Gear Shaft

Engine models 430000 and 580000 after date code 990111007 are equipped with right angle helical timing gears. Timing marks are identified by letters (A, AA, B, BB, etc.), instead of numbers. The timing procedure is the same.

5. With crankshaft key at 12 o'clock position, assemble idler gear so that timing mark 11 (AA) is aligned with timing mark 1 (A) on crankshaft gear, timing mark 22 (BB) is aligned with timing mark 2 (B) on camshaft gear as shown in Fig. 19.

- a. Install oil pump gear.

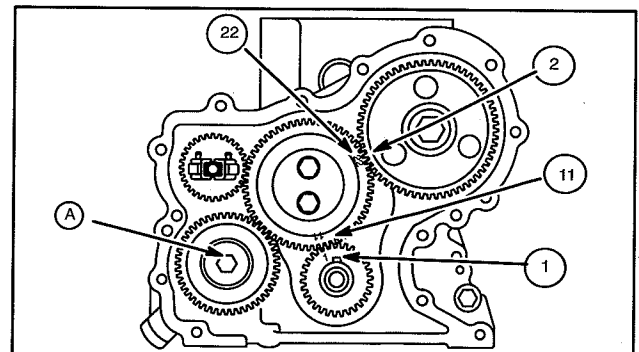

Fig. 19 - Aligning Timing Marks

6. Torque screws as shown, Fig. 20.
 - a. Camshaft gear: 41.0 Nm (30 ft. lbs.)
 - b. Idler gear: 25.0 Nm (220 in. lbs.)
 - c. Oil pump gear: 19.0 Nm (170 in. lbs.)

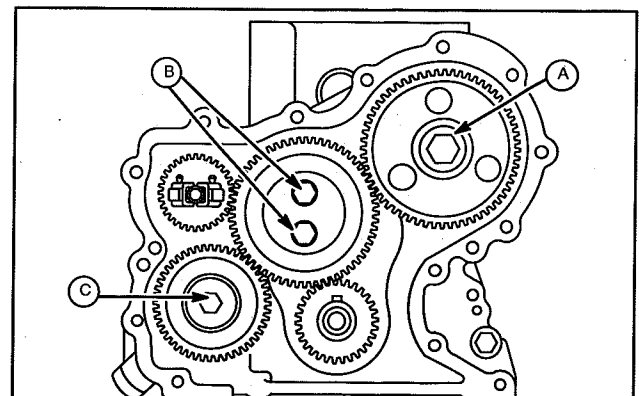

Fig. 20 - Torque Screws

GOVERNOR, TIMING GEARS AND GEAR CASE

7. Install timing gear cover with new gasket. Note position, length and number of screws as shown, Fig. 21.

- a. M6 x 65 mm (M6 x 2.5"): 2
- b. M6 x 55 mm (M6 x 2.1"): 3
- c. M6 x 30 mm (M6 x 1.1"): 7
- d. M6 Nut: 2

Torque screws and nuts to 8.0Nm (70 in. lbs.).

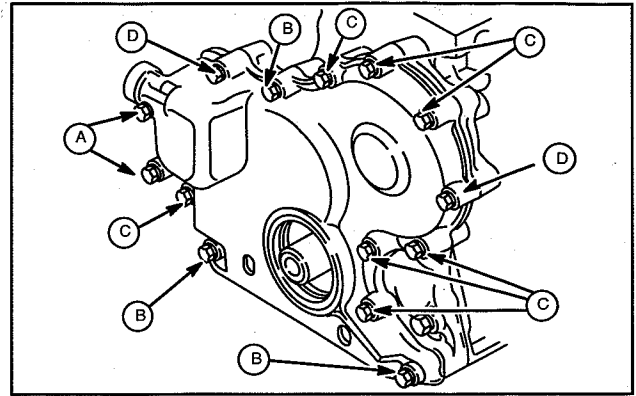

Fig. 21 – Installing Timing Gear Cover

8. Install crankshaft pulley with timing mark at 12 o'clock position (#1 cylinder), Fig. 22.

Note: Be sure alignment pin in crankshaft gear is seated in hole in pulley.

- a. Torque screw to 88.0 Nm (65 ft. lbs.).
- b. Remove flywheel holder.
- c. Install trigger assembly and wire.

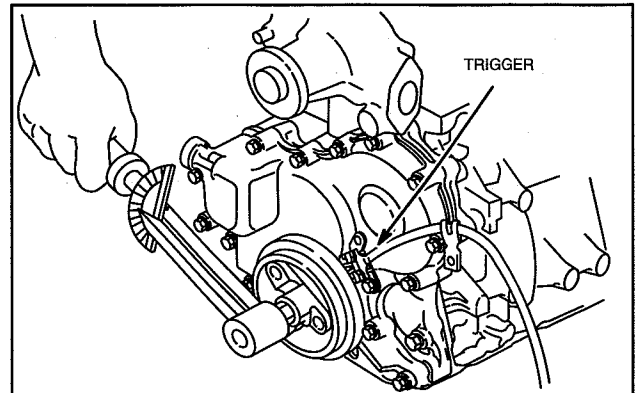

Fig. 22 – Installing Crankshaft Pulley

9. Install oil pick-up tube and strainer with new gasket. Torque to 8.0 Nm (70 in. lbs.).

- a. Apply a small bead of Permatex® No. 2 or similar sealant to crankcase areas shown, Fig. 23.
- b. Install oil pan with new gasket.
- c. Torque screws and nuts to 8.0 Nm (70 in. lbs.).

10. Install V-belt and fan (if equipped).

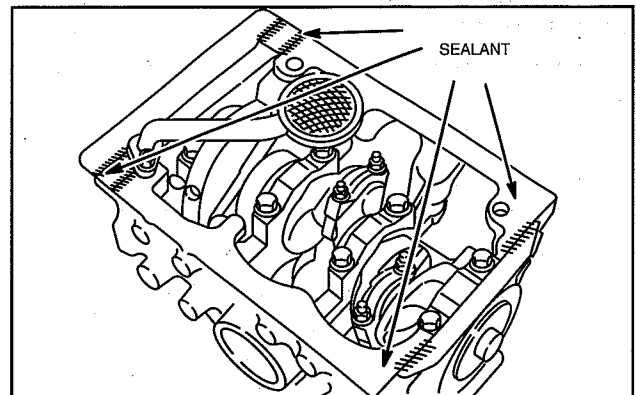

Fig. 23 – Installing Oil Pan

11. Install governor lever on to governor shaft, Fig. 24. Do not tighten governor nut at this time.

- a. Install governor link with spring.

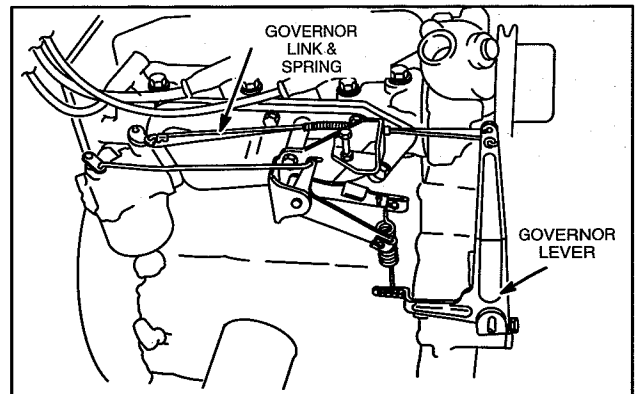

Fig. 24 – Installing Governor Lever

GOVERNOR, TIMING GEARS AND GEAR CASE

12. Insert governor spring into original hole in governor lever.

Note: Normal spring position is in center hole in governor lever, all models, Fig. 25.

Important: Governor spring must be installed in correct hole in governor control lever by engine model, Fig. 25.

- a. Model 430400 – Top Hole
- b. Model 580400 – Bottom Hole

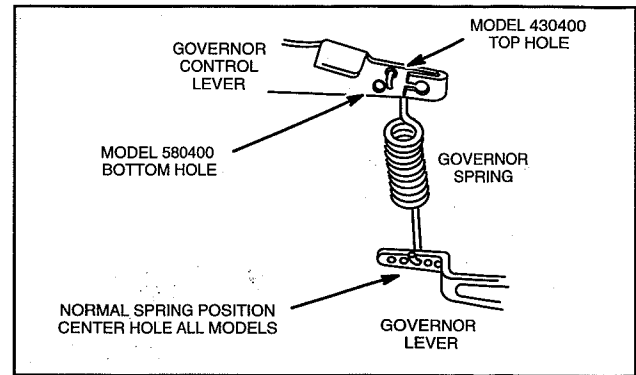

Fig. 25 – Governor Spring Position

ADJUST GOVERNOR

1. Move governor control lever up to end of travel and hold in this position (throttle wide open), Fig. 26.
 - a. Rotate governor shaft clockwise to end of travel.
 - b. Torque governor nut to 10.0 Nm (90 in. lbs.).

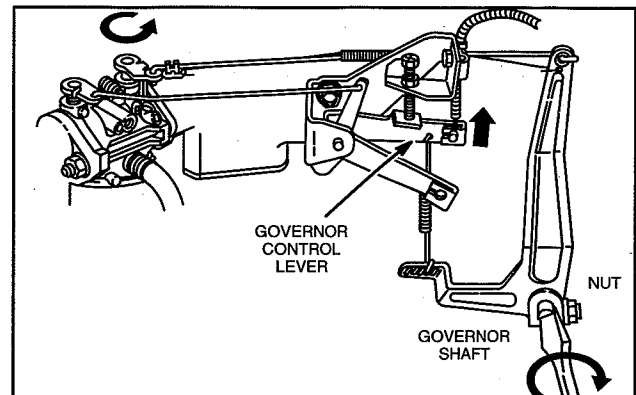

Fig. 26 – Adjusting Governor

TROUBLESHOOTING

Engine Hunts

If engine hunts at top no load speed, check governor adjustment as follows:

1. Stop engine.
2. Move equipment control to “Fast” position.
3. Disconnect governor link spring and link.
4. Rotate throttle to wide open position.
 - a. Position of governor link must be within 1 mm of center of hole in throttle lever as shown in Fig. 27.

If dimension is greater than 1 mm, perform governor adjustment.

If engine continues to hunt at top no load speed, decrease governor sensitivity by moving governor spring to next hole on governor lever, Fig. 28.

Note: Moving spring away from governor shaft pivot point decreases sensitivity. Moving spring towards governor shaft pivot point increases sensitivity.

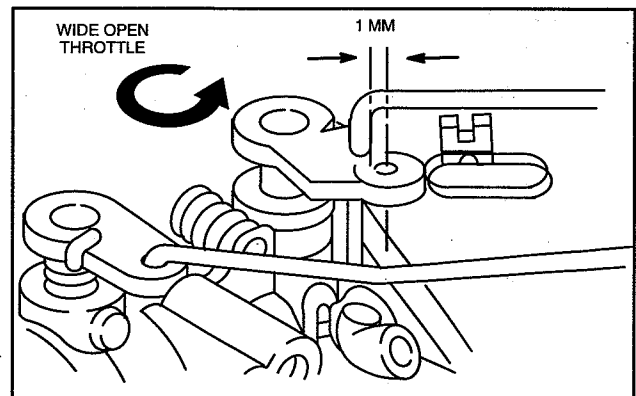

Fig. 27 – Checking Adjustment

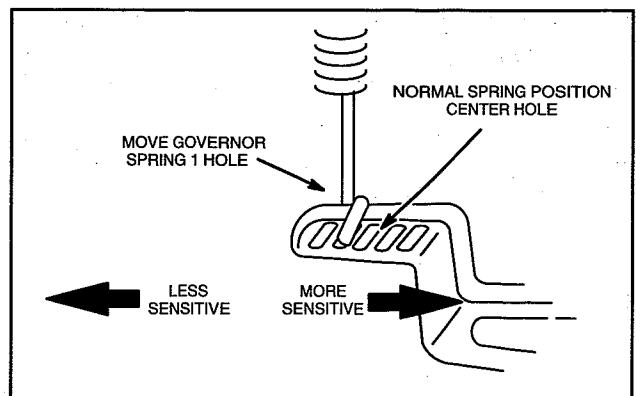
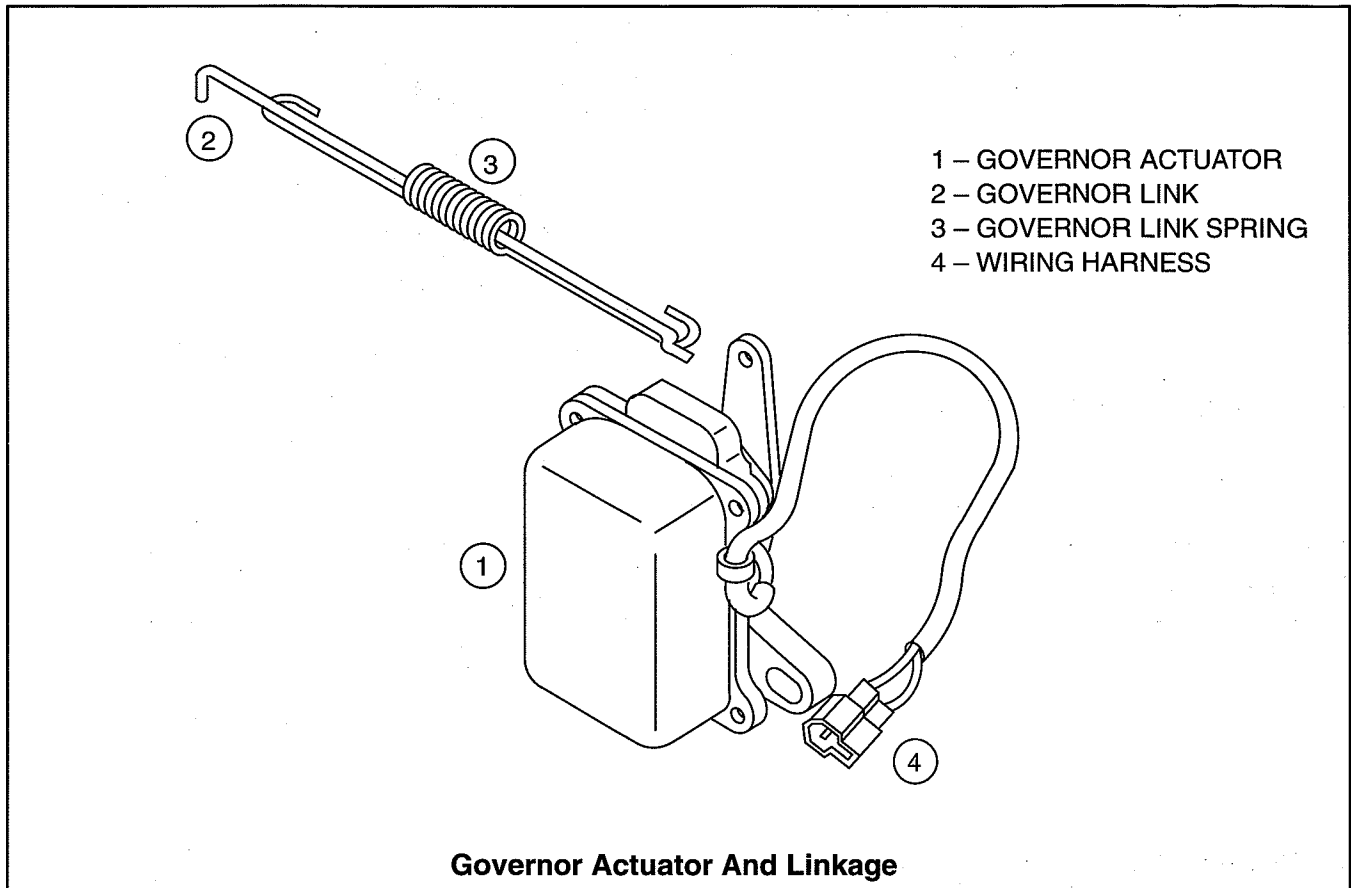

Fig. 28 – Adjusting Governor Sensitivity

ELECTRONIC GOVERNOR

The ignition module and related wiring for the electronic governor is supplied by the equipment manufacturer.

Note: Engines equipped with electronic governor do not have mechanical governor components.



CHECKING GOVERNOR ACTUATOR

Disconnect harness at connector and attach test leads as shown, Fig. 29.

1. Touch test leads to terminals of a known good 12 volt battery.
 - a. Actuator lever should quickly move throttle lever to wide open position.
2. Remove test leads from battery terminals:
 - a. Actuator lever should quickly move throttle lever to idle position.

Replace actuator if not to specification.

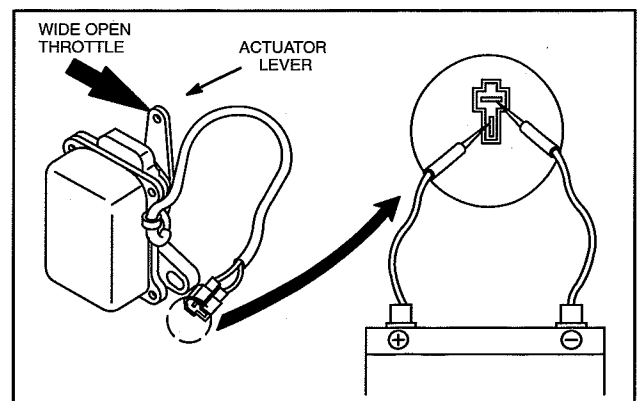

Fig. 29 - Checking Governor Actuator

ELECTRONIC GOVERNOR

REMOVE GOVERNOR ACTUATOR

1. Disconnect governor link spring and link.
2. Remove two screws and actuator.

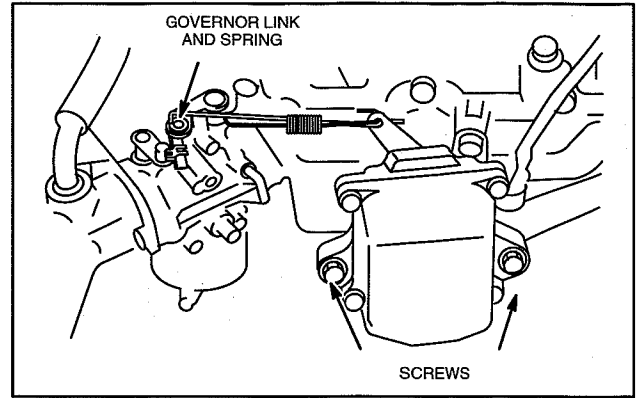

Fig. 30 – Removing Governor Actuator

INSTALL GOVERNOR ACTUATOR

1. Assemble governor link spring and link to actuator lever as shown, Fig. 31.

Note: Open ends of spring must face cylinder head.

2. Assemble actuator to mounting bracket loosely. Do not tighten screws.

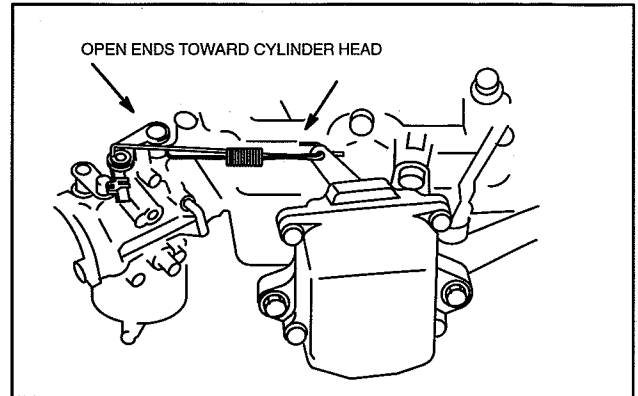

Fig. 31 – Install Actuator

3. Rotate throttle lever clockwise to end of travel (throttle closed) and hold in this position.
4. Slide actuator until governor link is positioned slightly to rear of hole in throttle lever bushing, Fig. 32.
5. Torque actuator mounting screws to 8.0 Nm (70 in. lbs.).
 - a. Assemble governor link and spring to throttle lever.

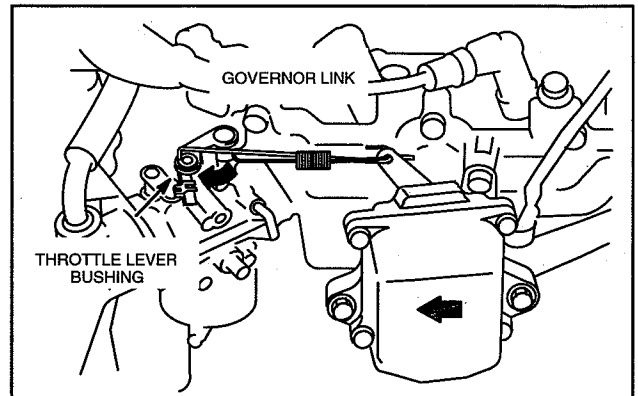
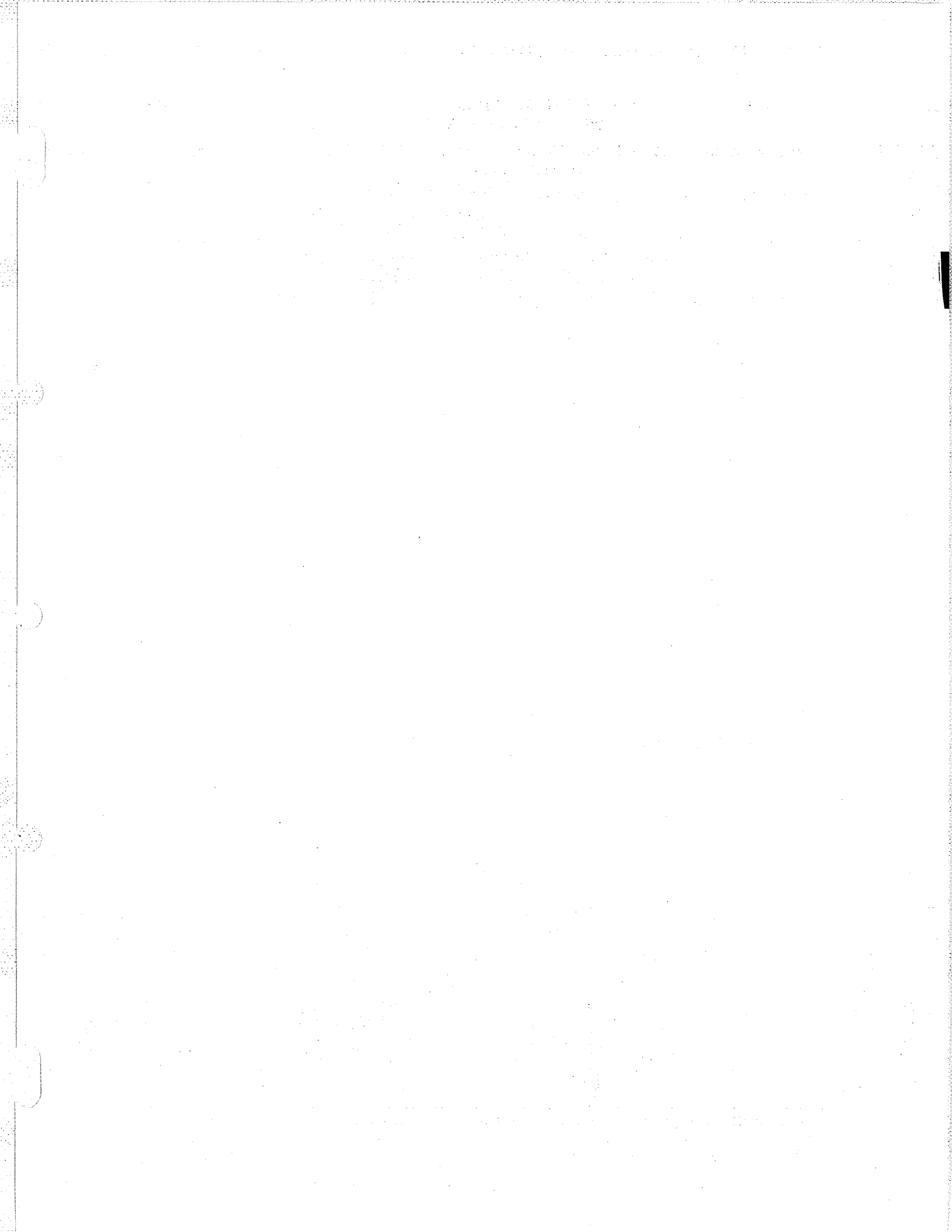

Fig. 32 – Adjust Actuator



[The page contains extremely faint and illegible text, likely bleed-through from the reverse side of the document. The text is too light to transcribe accurately.]

Section 4 Flywheel And Rear Seal Retainer

Section Contents

Page

REMOVING OIL PAN AND FLYWHEEL	1
REMOVING REAR SEAL RETAINER	2
REPLACING OIL SEAL	2
INSTALLING REAR SEAL RETAINER AND FLYWHEEL	2
INSTALL OIL PAN	3

4

REMOVING PAN AND FLYWHEEL

Drain oil from engine.

1. Remove oil pan screws and nuts. Remove oil pan and discard gasket, Fig. 1.

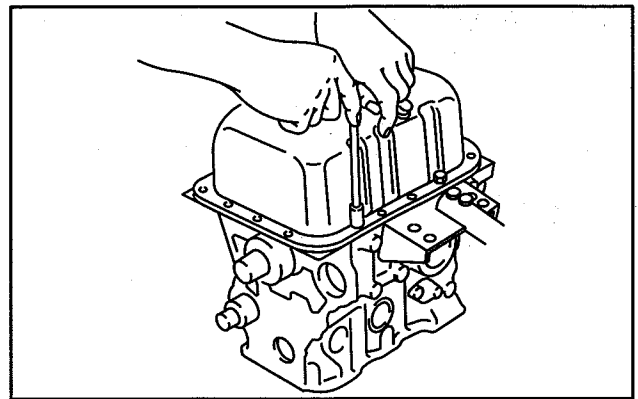

Fig. 1 – Removing Oil Pan

2. Install flywheel holder, Tool #19418
 - a. Remove flywheel screws and flywheel, Fig. 2.

Inspect flywheel for cracks or damage. Inspect flywheel ring gear for worn, chipped or cracked teeth.

If ring gear is worn or damaged the flywheel must be replaced.

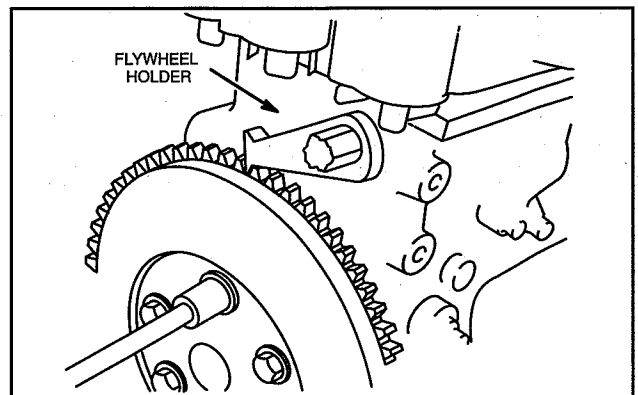

Fig. 2 – Removing Flywheel

FLYWHEEL AND REAR SEAL RETAINER

REMOVE REAR SEAL RETAINER

Remove rear seal retainer and discard gasket, Fig. 3.

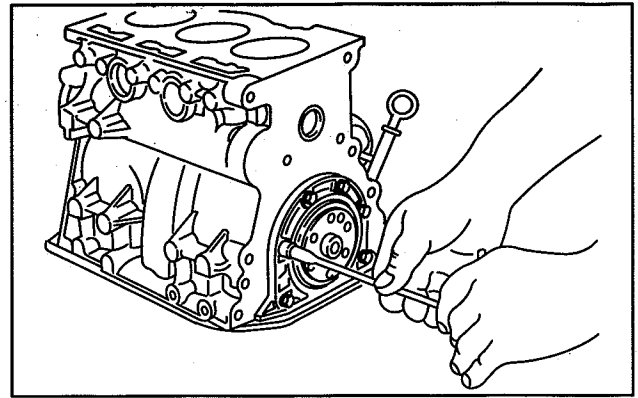

Fig. 3 – Removing Seal Retainer

REPLACING OIL SEAL

1. Remove oil seal, Fig. 4.

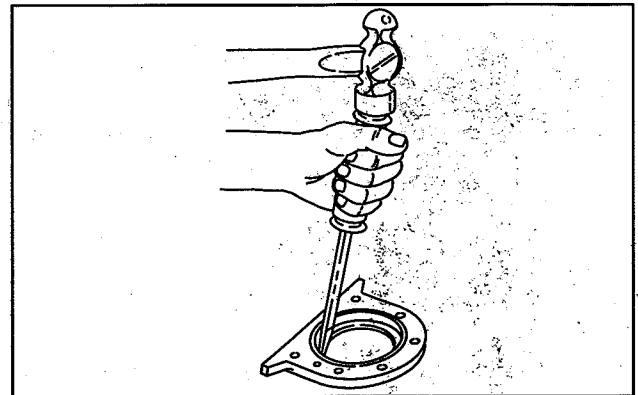

Fig. 4 – Removing Oil Seal

2. Lubricate outside diameter of oil seal.

- a. Using seal driver, Tool #19424 install new oil seal, Fig. 5.

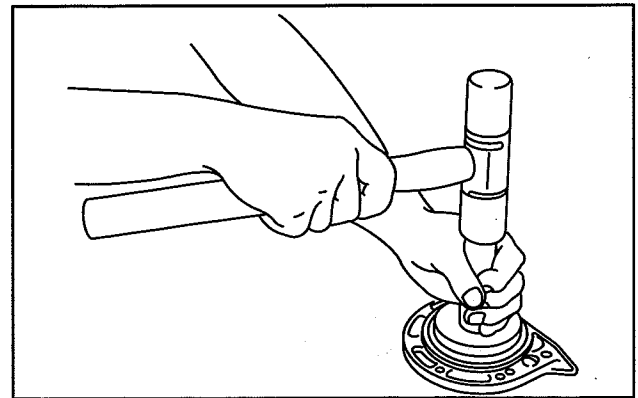

Fig. 5 – Installing Oil Seal

INSTALLING REAR SEAL RETAINER AND FLYWHEEL

1. Install rear seal retainer with new gasket, Fig. 6.
 - a. Torque screws to 6.0 Nm (50 in. lbs.).

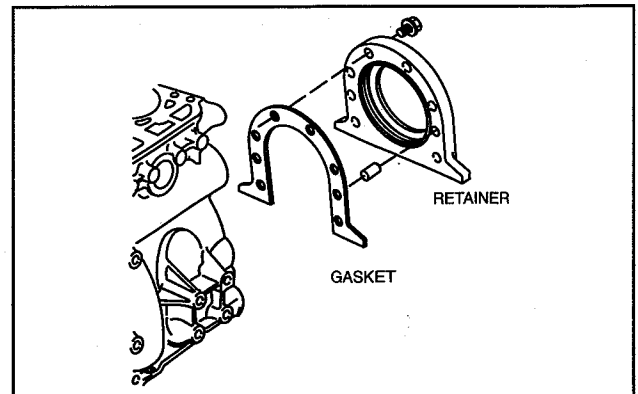

Fig. 6 – Installing Seal Retainer

FLYWHEEL AND REAR SEAL RETAINER

2. Install flywheel, Fig. 7.

Note: Apply Permatex® No. 2 or similar sealant to flywheel screws.

- a. Torque flywheel screws to 47.0 Nm (35 ft. lbs.).

Remove flywheel holder.

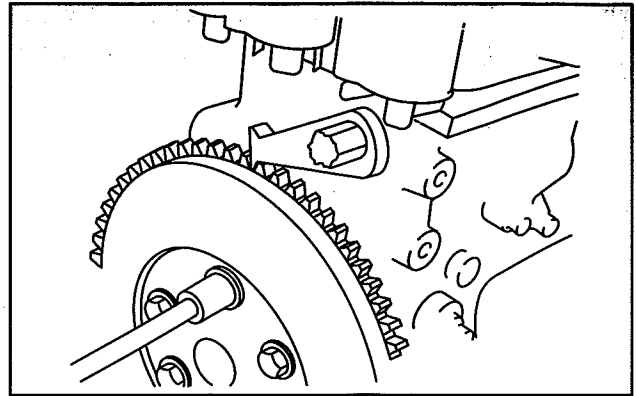

Fig. 7 – Installing Flywheel

INSTALL OIL PAN

1. Install oil pan with new gasket, Fig. 8.

- a. Apply a small bead of Permatex® No. 2 or similar sealant to crankcase areas shown.
- b. Torque screws and nuts to 8.0 Nm (70 in. lbs.).

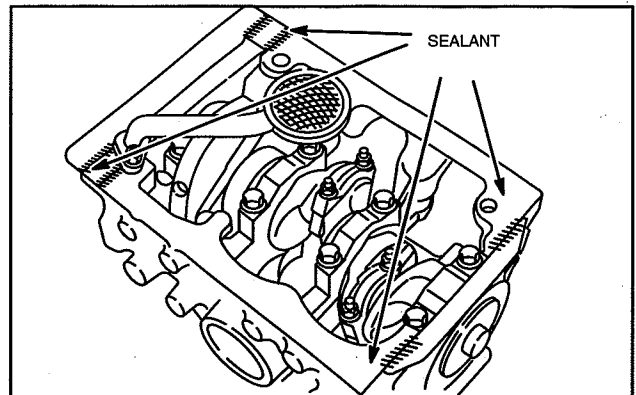

Fig. 8 – Installing Oil Pan

Section 5

Cylinder Block Disassembly

Section Contents

	Page
ENGINE STAND FIXTURE	2
CYLINDER BLOCK DISASSEMBLY	2

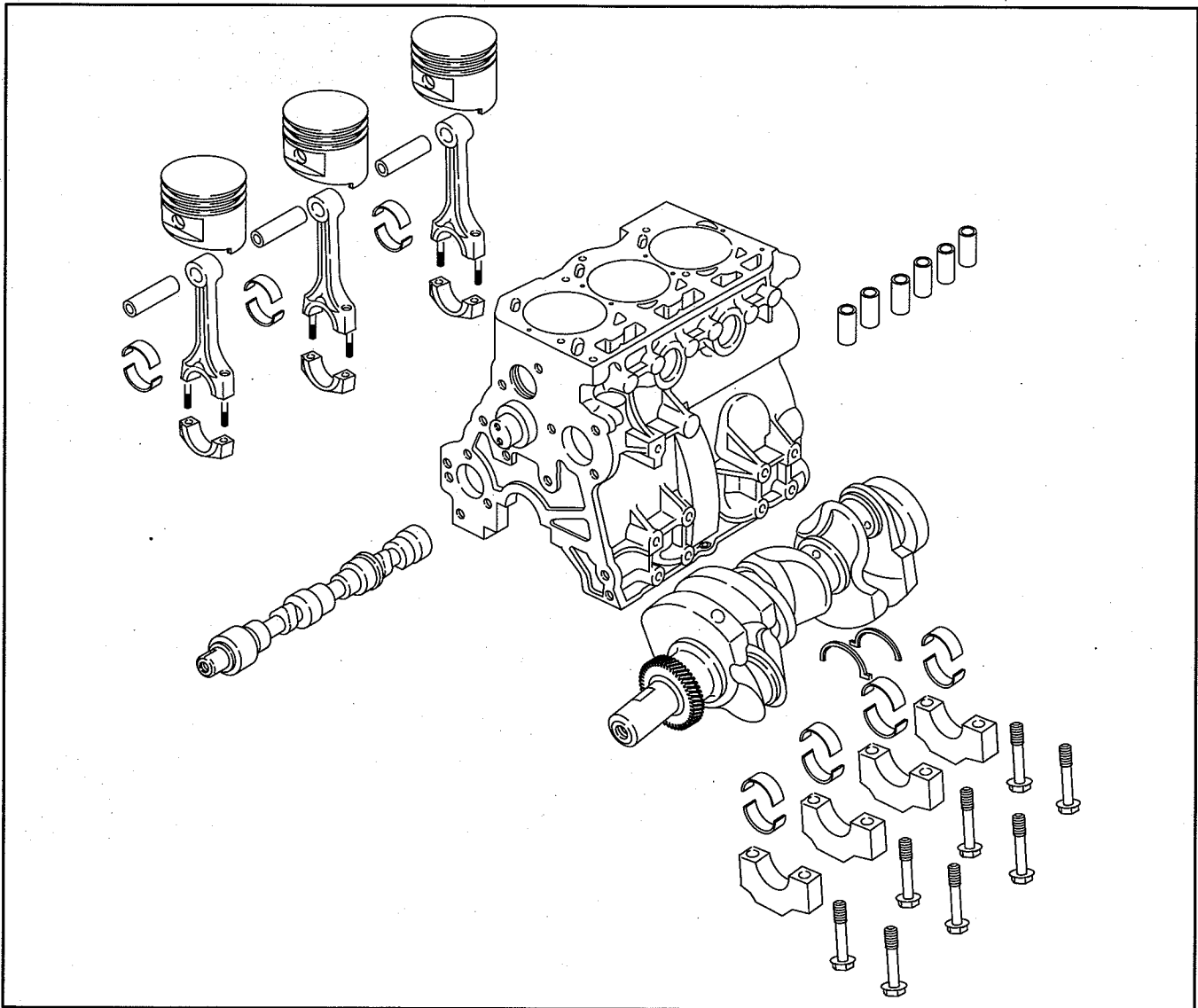

CYLINDER BLOCK DISASSEMBLY

An automotive type engine stand is recommended when complete engine disassembly is required. See drawings below for dimensions to make an engine stand mounting fixture. The engine stand shown below is manufactured by Snap-On®.

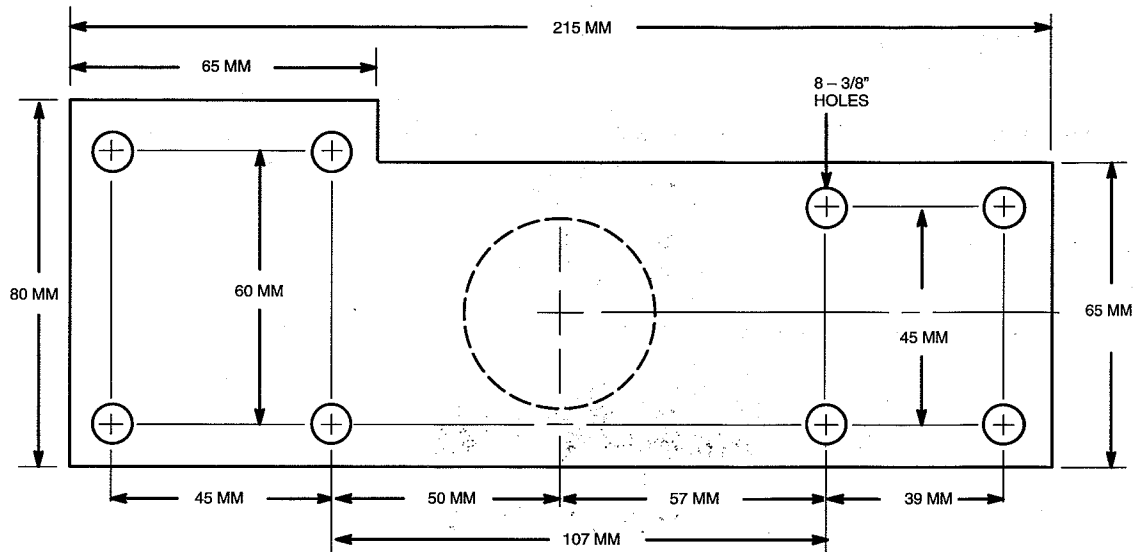

Mounting Plate

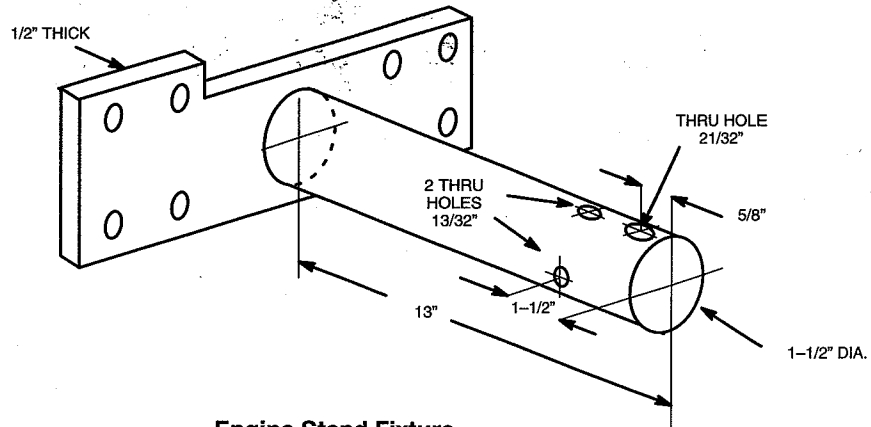

Engine Stand Fixture

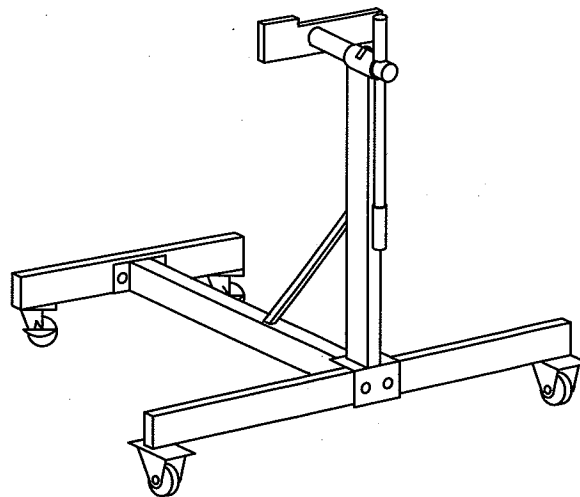

CYLINDER BLOCK DISASSEMBLY

1. Remove cylinder head. See Sec. 2.
2. Remove oil pan, timing cover, gears and case. See Sec. 3.
3. Remove flywheel and rear seal retainer. See Sec. 4.
4. Remove starter motor, Fig. 1.

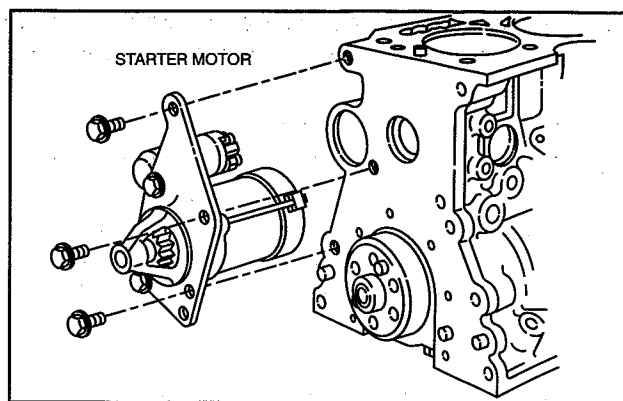

Fig. 1 – Removing Starter And Bracket

5. Remove alternator bracket and alternator, Fig. 2.

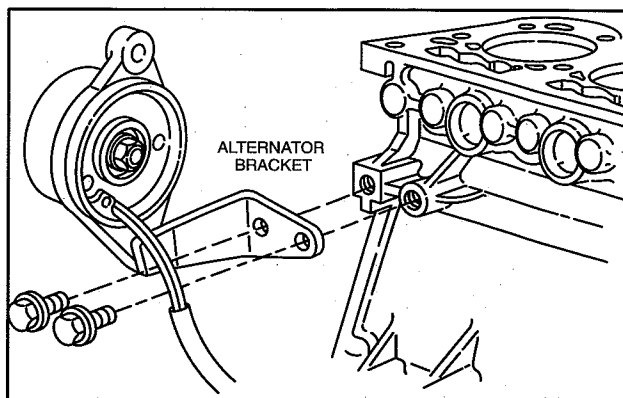

Fig. 2 – Removing Alternator

6. Remove valve lifters, Fig. 3.
 - a. Number lifters so that they may be re-installed in the same position.

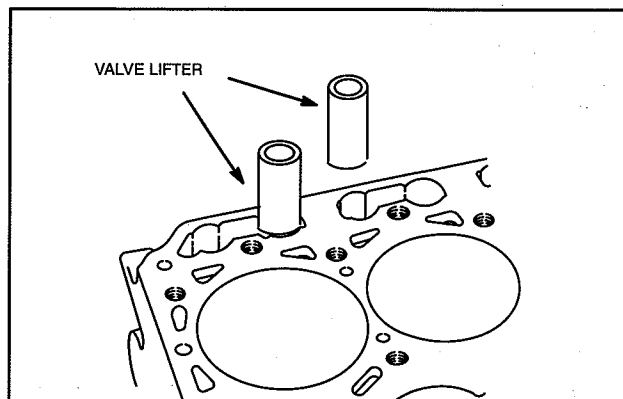

Fig. 3 – Removing Valve Lifters

7. Remove camshaft, Fig. 4.

Note: Use care when removing camshaft to prevent damaging cam bearing, journals and lobes.

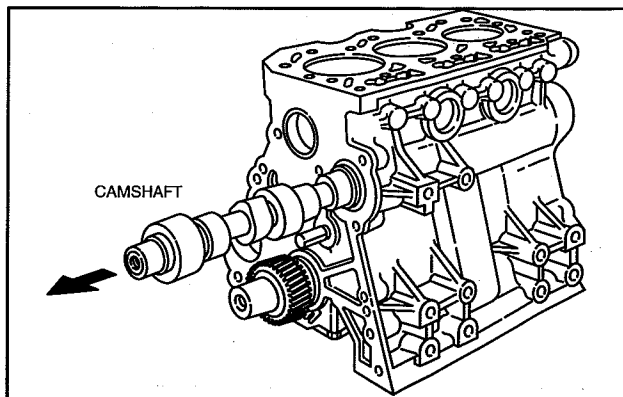

Fig. 4 – Removing Camshaft

CYLINDER BLOCK DISASSEMBLY

8. Remove oil pick-up tube and strainer, Fig. 5. Discard gasket.

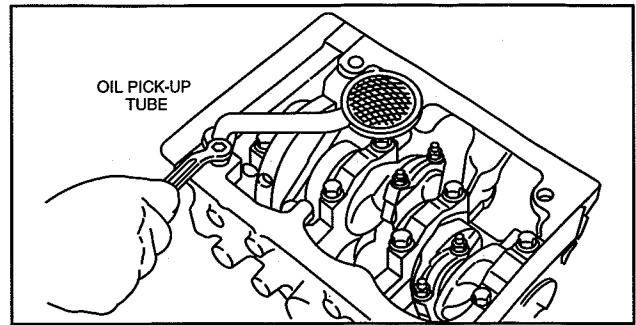

Fig. 5 – Removing Oil Pick-Up

9. Remove connecting rod and piston assemblies, Fig. 6.

Note: Remove carbon or ridge from cylinder and number connecting rod/piston assemblies before removing from cylinders.

- a. Remove connecting rod cap with lower bearing.
- b. Push connecting rod and piston out through top of cylinder.
- c. Reassemble connecting rod cap to connecting rod to prevent interchanging components.

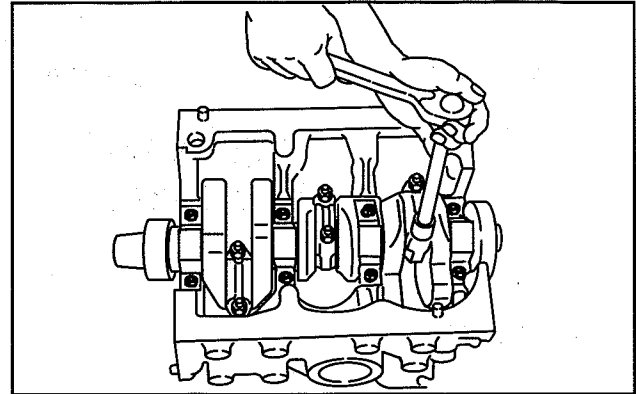

Fig. 6 – Removing Connecting Rod Assembly

10. Remove crankshaft main bearing caps, keeping main bearings with their respective caps, Fig. 7.

Note: Main bearing caps are numbered 1 through 4.

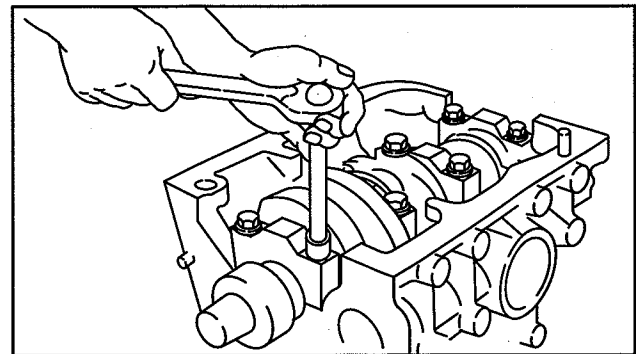

Fig. 7 – Removing Main Bearing Caps

11. Remove crankshaft, Fig. 8.

- a. Remove crankshaft thrust washers (#3 main bearing).
- b. Remove upper main bearings from saddles and place with respective bearing caps.

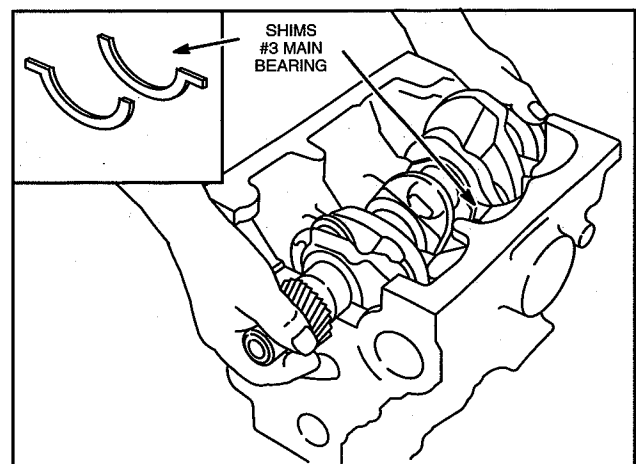
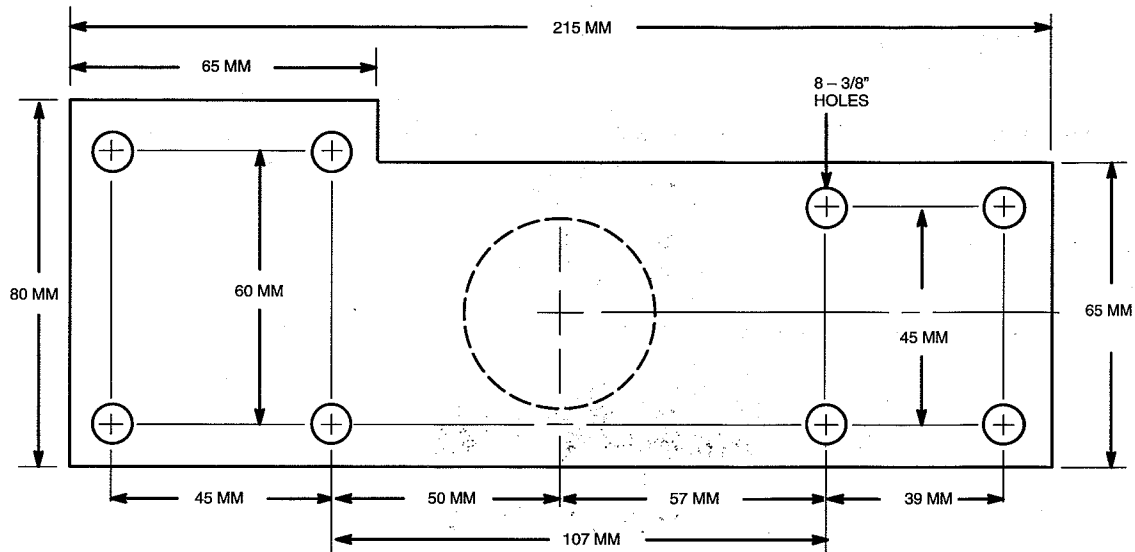

Fig. 8 – Removing Crankshaft

CYLINDER BLOCK DISASSEMBLY

An automotive type engine stand is recommended when complete engine disassembly is required. See drawings below for dimensions to make an engine stand mounting fixture. The engine stand shown below is manufactured by Snap-On®.



Mounting Plate

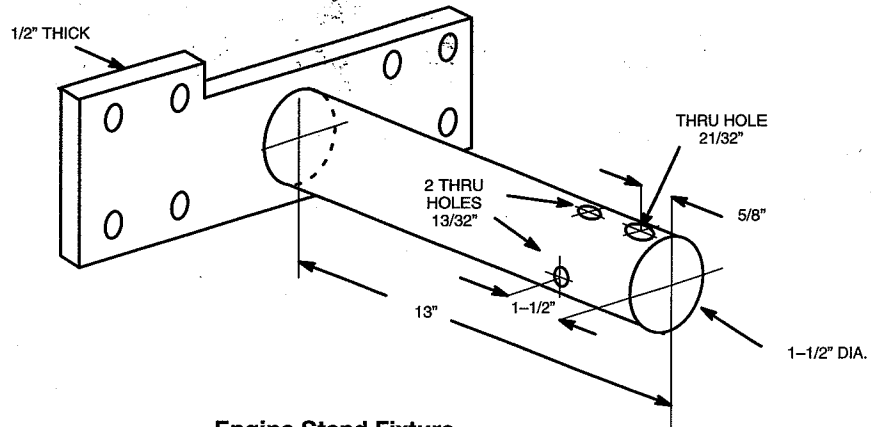

Engine Stand Fixture

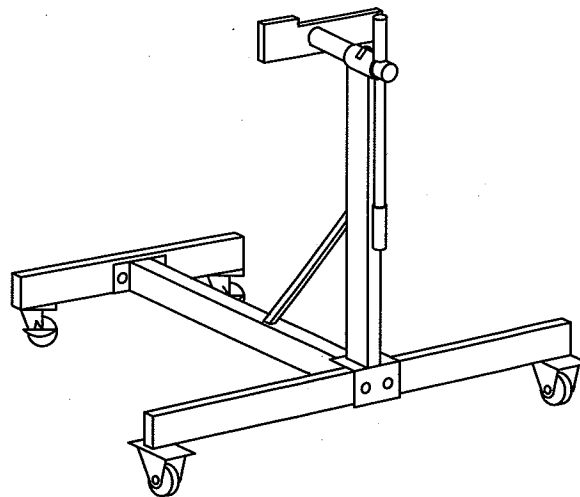

CYLINDER BLOCK DISASSEMBLY

1. Remove cylinder head. See Sec. 2.
2. Remove oil pan, timing cover, gears and case. See Sec. 3.
3. Remove flywheel and rear seal retainer. See Sec. 4.
4. Remove starter motor, Fig. 1.

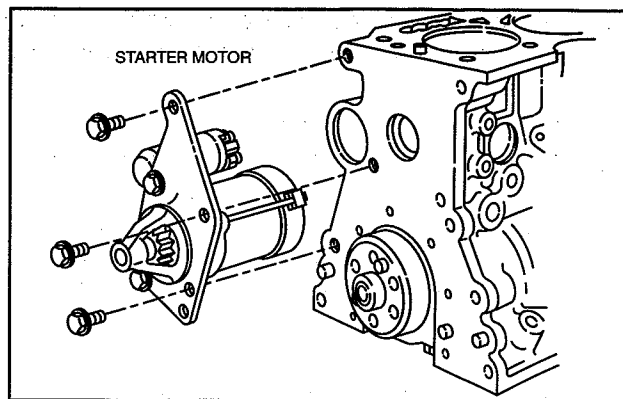

Fig. 1 – Removing Starter And Bracket

5. Remove alternator bracket and alternator, Fig. 2.

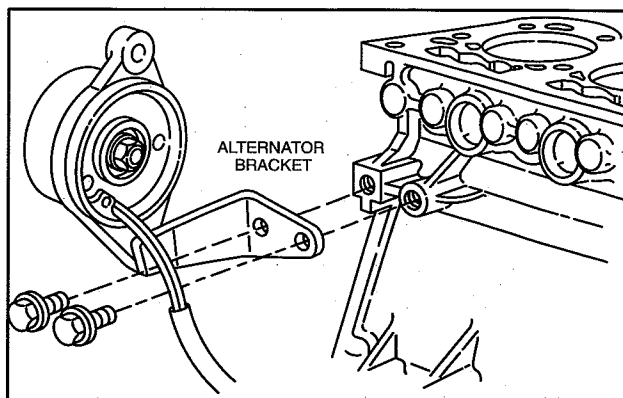

Fig. 2 – Removing Alternator

6. Remove valve lifters, Fig. 3.
 - a. Number lifters so that they may be re-installed in the same position.

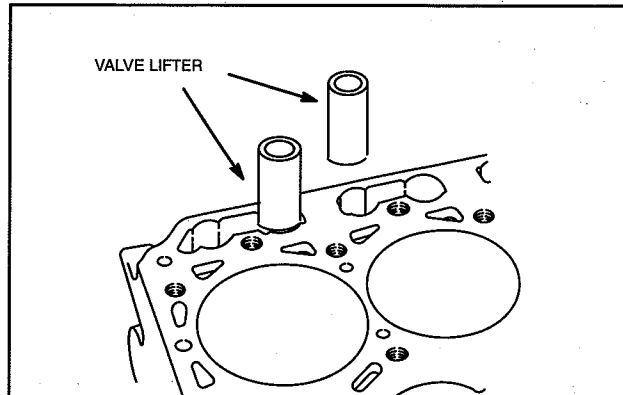

Fig. 3 – Removing Valve Lifters

7. Remove camshaft, Fig. 4.

Note: Use care when removing camshaft to prevent damaging cam bearing, journals and lobes.

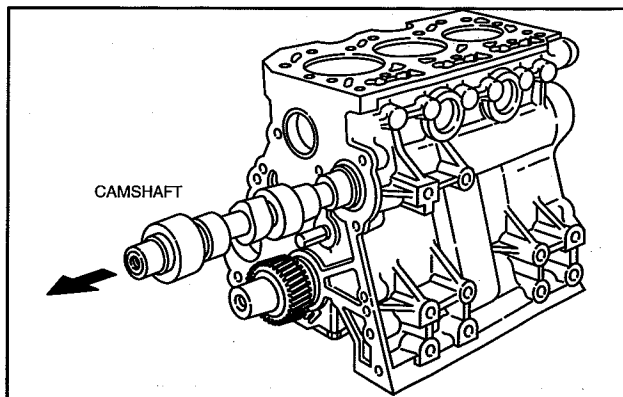

Fig. 4 – Removing Camshaft

CYLINDER BLOCK DISASSEMBLY

8. Remove oil pick-up tube and strainer, Fig. 5. Discard gasket.

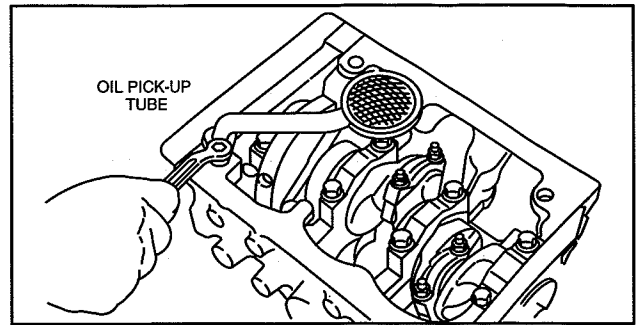

Fig. 5 – Removing Oil Pick-Up

9. Remove connecting rod and piston assemblies, Fig. 6.

Note: Remove carbon or ridge from cylinder and number connecting rod/piston assemblies before removing from cylinders.

- a. Remove connecting rod cap with lower bearing.
- b. Push connecting rod and piston out through top of cylinder.
- c. Reassemble connecting rod cap to connecting rod to prevent interchanging components.

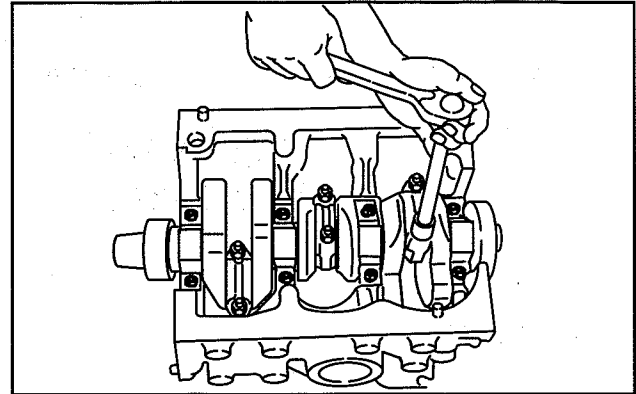

Fig. 6 – Removing Connecting Rod Assembly

10. Remove crankshaft main bearing caps, keeping main bearings with their respective caps, Fig. 7.

Note: Main bearing caps are numbered 1 through 4.

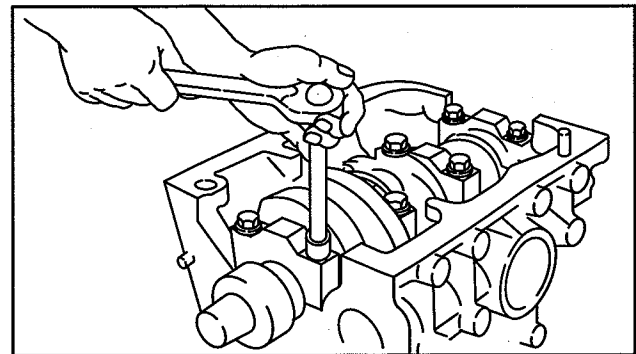

Fig. 7 – Removing Main Bearing Caps

11. Remove crankshaft, Fig. 8.

- a. Remove crankshaft thrust washers (#3 main bearing).
- b. Remove upper main bearings from saddles and place with respective bearing caps.

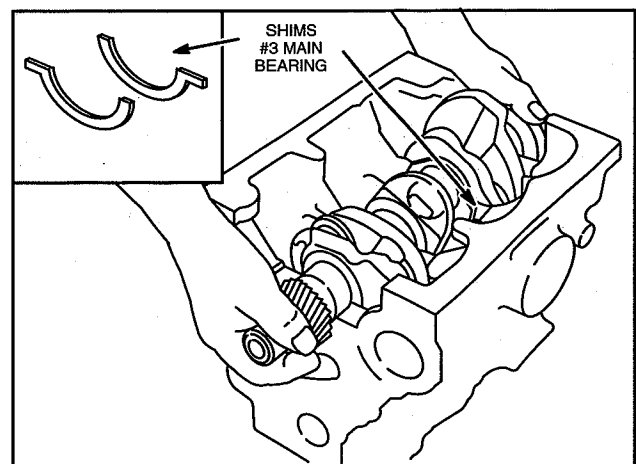

Fig. 8 – Removing Crankshaft

Section 6

Cylinder Block Inspection And Repair

Section Contents

	Page
CHECKING CYLINDER BLOCK	1
REPLACING CAMSHAFT BEARING	2
REPLACING CAMSHAFT PLUG	3

CHECKING CYLINDER BLOCK

Remove all traces of sealant and gasket material from mounting surfaces. Inspect cylinder block for damage, cracks and stripped threads. Inspect cylinder bores for damage or scores.

1. Check cylinder block deck for distortion, Fig. 1.
Distortion Limit: 0.08 mm (.003")

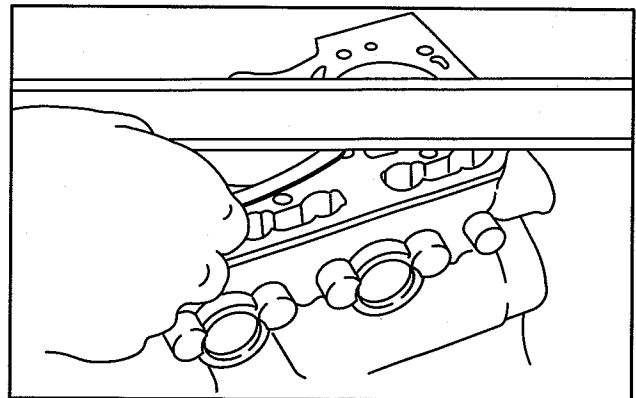

Fig. 1 - Checking Cylinder Block

2. If cylinder block exceeds limit shown, it may be resurfaced, Fig. 2.

Cylinder Block Height

Model Series 430000 Std: 229.20 - 229.80 mm
(9.023 - 9.047")

**Minimum Dimension:
(After Resurfacing)** 229.10 mm (9.019")

Model Series 580000 Std: 238.70 - 239.30 mm
(9.3976 - 9.421")

**Minimum Dimension:
(After Resurfacing)** 238.60 mm (9.3937")

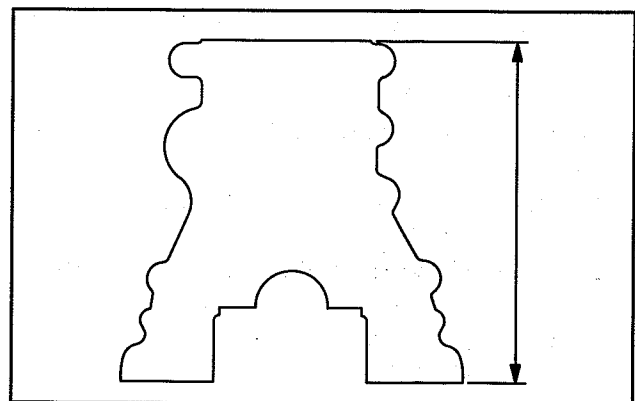

Fig. 2 - Cylinder Block Height

CYLINDER BLOCK INSPECTION AND REPAIR

3. Check cylinder bores for wear, Fig. 3.

Standard Bore Size:

Model Series 430000 68.00 – 68.030 mm
(2.6770 – 2.6783")

Model Series 580000 72.00 – 72.030 mm
(2.8346 – 2.8358")

- Measure cylinder bore in 6 points at right angles as shown, Fig. 3.
- If cylinder bore is worn more than 0.075 mm (.003") or more than 0.035 mm (.0015") out of round, it must be resized.

Always resize to exactly .25 mm (.010") over standard bore size. If this is done accurately, the service oversize rings and pistons will fit perfectly and proper clearances will be maintained.

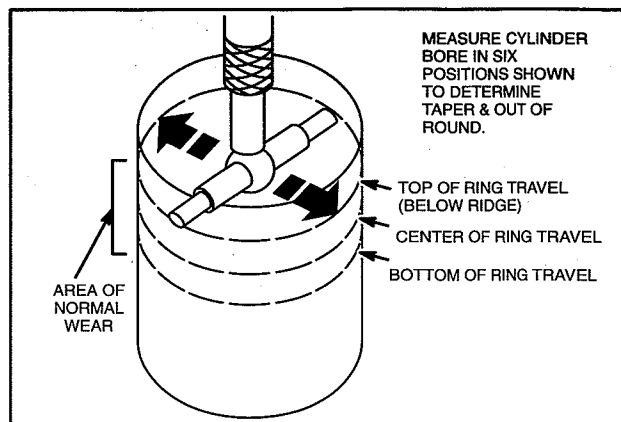

Fig. 3 – Checking Cylinder Bore

4. Check valve lifter bore, Fig. 4.

Std. Dimension: 18.018 mm (.7093")

Reject: 18.05 mm (.711")

5. Check valve lifter, Fig. 4.

Std. Dimension: 17.98 mm (.708")

Reject: 17.91 mm (.705")

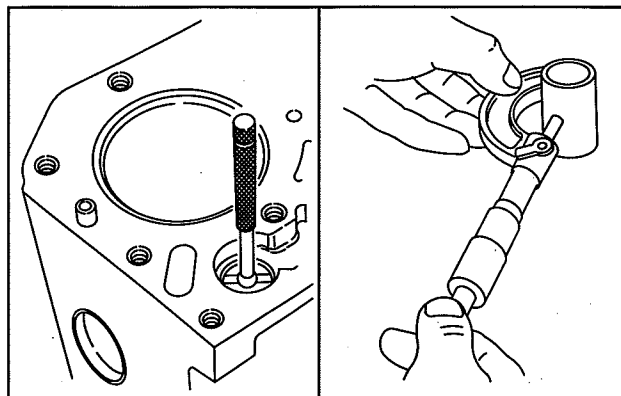

Fig. 4 – Checking Valve Lifter And Bore

6. Check camshaft bearing, Fig. 5.

Replace if greater than 36.06 mm (1.420").

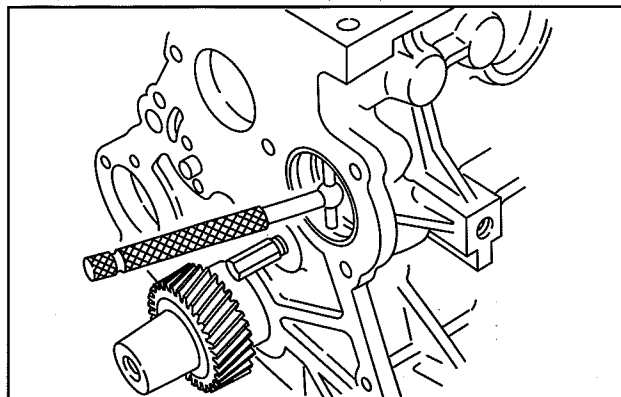

Fig. 5 – Checking Cam Bearing

REPLACING CAMSHAFT BEARING

1. Remove camshaft bearing, Fig. 6.

- Use camshaft bearing puller, Tool #19421.

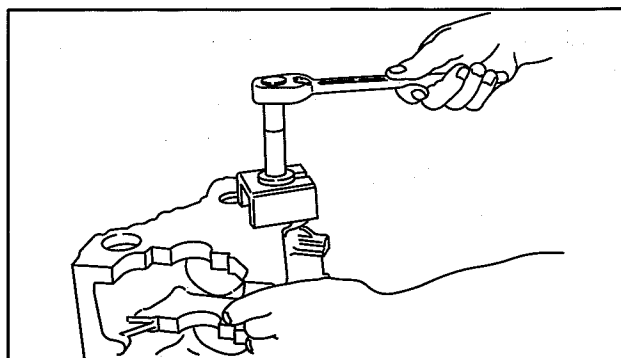

Fig. 6 – Removing Cam Bearing

2. Install camshaft bearing, Fig. 7.
 - a. Use camshaft bearing driver, Tool #19422.

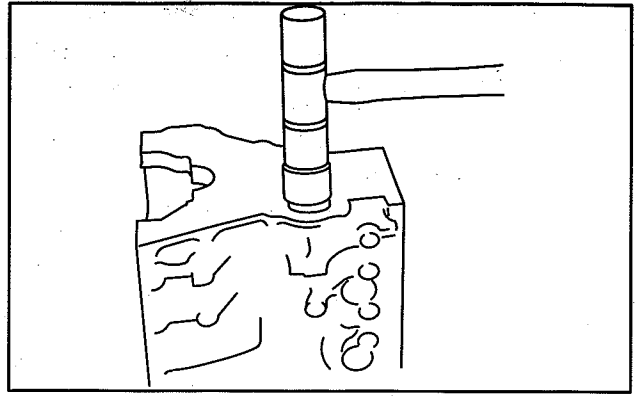

Fig. 7 – Installing Cam Bearing

REPLACING CAMSHAFT PLUG

1. Remove rear camshaft plug, Fig. 8.
 - a. Use a wood dowel or brass rod to prevent damage to camshaft bearing.
2. Install new camshaft plug using camshaft bearing driver, Tool #19422.
 - a. Install camshaft plug flush with cylinder block, Fig. 9.

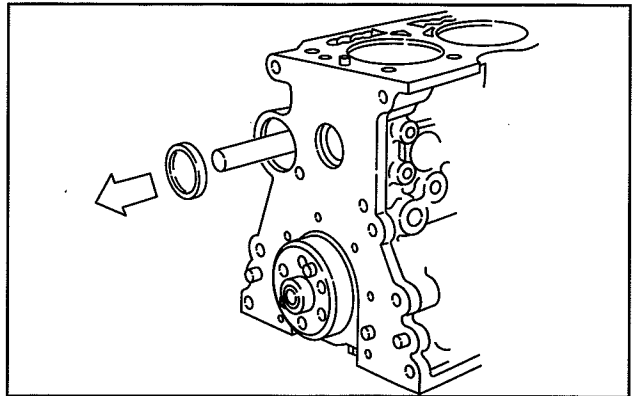

Fig. 8 – Removing Camshaft Plug

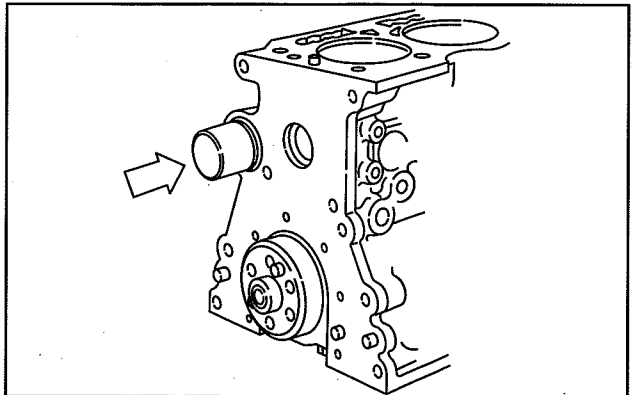

Fig. 9 – Installing Camshaft Plug

If cylinder block is being resized, the following parts should be removed so that cylinder block may be thoroughly cleaned.

1. Remove oil pressure switch, water gallery plug and oil filter adapter, Fig. 10.

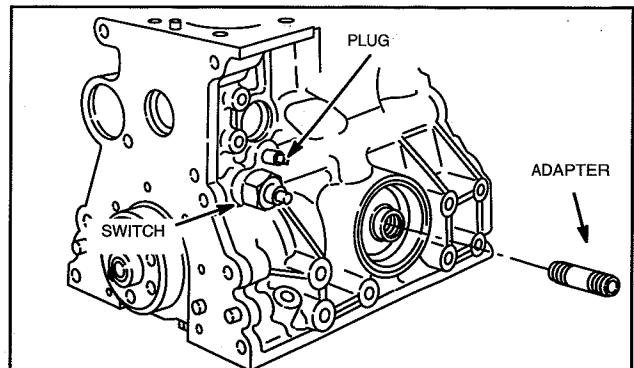

Fig. 10 – Removing Oil Pressure Switch

CYLINDER BLOCK INSPECTION AND REPAIR

2. Remove timing gear oil nozzle, Fig. 11.

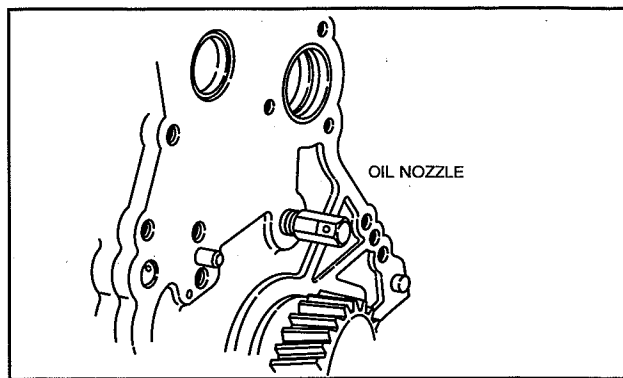

Fig. 11 – Removing Oil Nozzle

3. When reinstalling oil nozzle, oil hole must be positioned at 45° angle, pointing towards idler gear, Fig. 12.

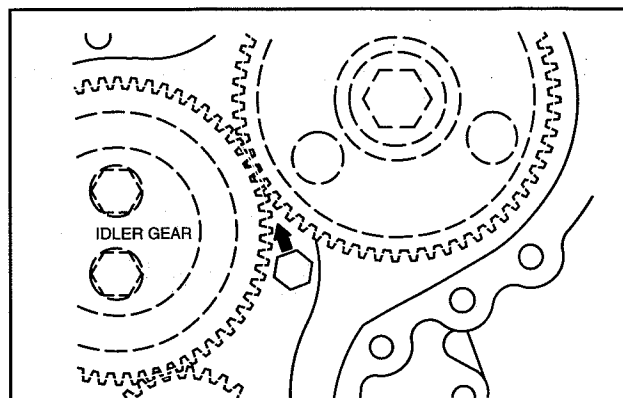

Fig. 12 – Installing Oil Nozzle

Section 8

Piston, Rings and Connecting Rod Inspection And Assembly

Section Contents

	Page
DISASSEMBLE PISTON AND CONNECTING ROD	1
CHECKING PISTON AND RINGS	2
CHECKING PISTON PIN AND CONNECTING ROD	2
ASSEMBLE PISTON AND CONNECTING ROD	3
ASSEMBLE PISTON RINGS TO PISTON	4

DISASSEMBLE PISTON AND CONNECTING ROD

1. Remove compression rings using ring expander, Tool #19340, Fig. 1.
 - a. Oil ring may be removed by hand by spiraling top scraper into center ring groove, then into top groove and off piston. Repeat for bottom scraper. Then remove expander.

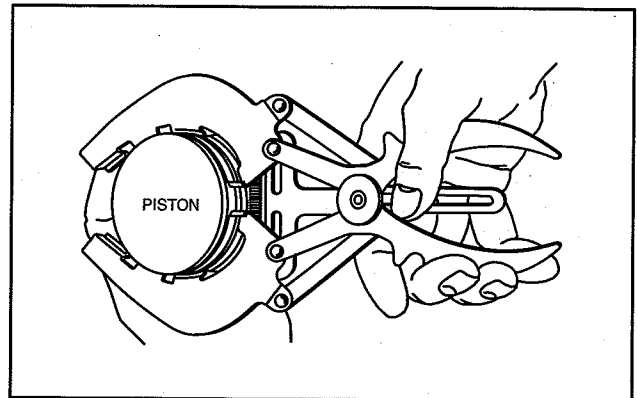

Fig. 1 - Removing Piston Rings

2. Disassemble piston from connecting rod using piston pin fixture, Tool #19419, Fig. 2.

Note: Piston pin stop must be removed from support when disassembling piston and connecting rod.

- a. Insert threaded driver through piston pin from FRONT side of piston and thread into pilot.
- b. Place piston with driver onto support with arrow on piston facing up.
- c. Press out piston pin.

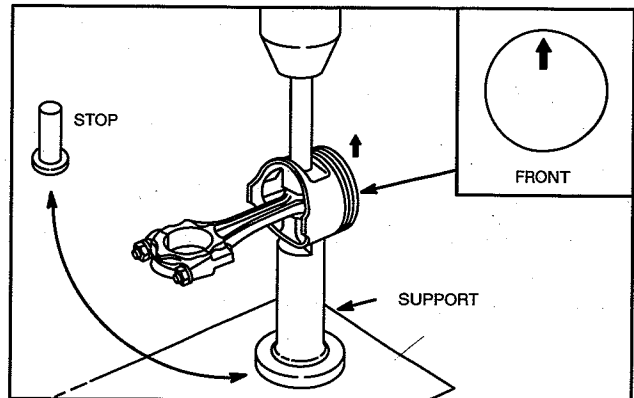

Fig. 2 - Disassembling Piston/Connecting Rod

PISTON, RINGS AND CONNECTING ROD INSPECTION AND ASSEMBLY

CHECKING PISTON AND RINGS

If the cylinder bore is to be resized there is no reason to check the piston as a new oversized piston will be used.

If the cylinder is not going to be resized and the piston shows no signs of scoring, the piston should be checked.

1. Check side clearance of ring grooves using NEW rings, Fig. 3. If a 0.11 mm (0.0045") feeler gauge can be inserted, the ring groove is worn. The piston must be replaced.

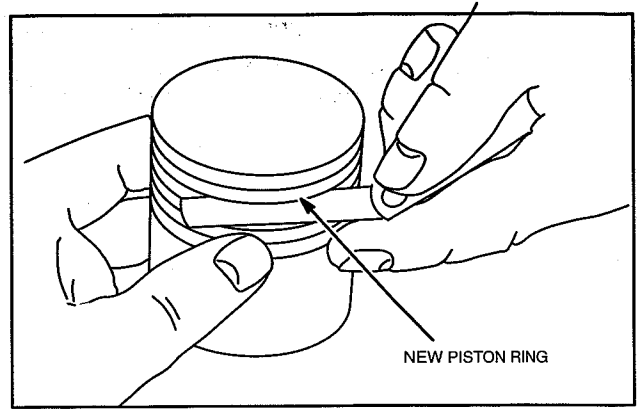

Fig. 3 – Checking Ring Grooves

2. Check ring end gap, Fig. 4.
 - a. Clean carbon from end of rings and insert approximately 25 mm (1") into cylinder.

Ring End Gap Reject Size	
Compression Rings	Oil Ring
0.53 mm (0.021")	0.68 mm (0.027")

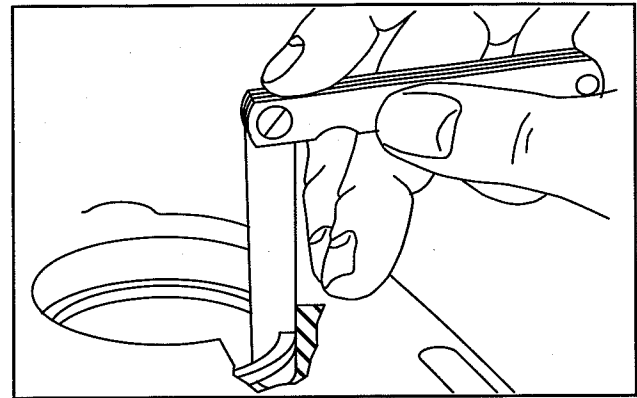

Fig. 4 – Checking End Gap

3. Check piston pin bore, Fig. 5.
 - a. **Replace** if greater than 18.03 mm (0.710") or .01 mm (.0004") out of round.

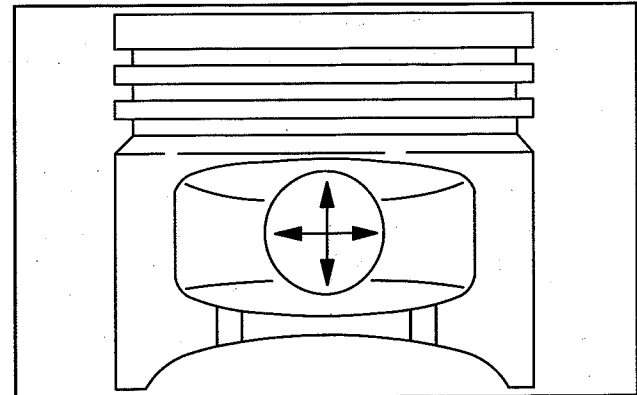

Fig. 5 – Checking Piston Pin Bore

CHECKING PISTON PIN AND CONNECTING ROD

1. Check piston pin, Fig. 6.
 - a. **Replace** if less than 17.98 mm (0.708") or .01 mm (.0004") out of round.

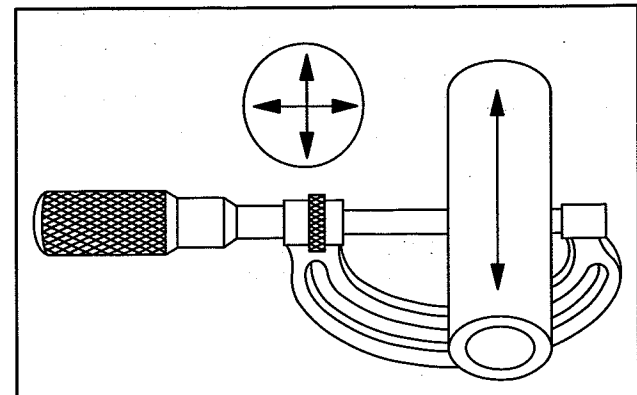

Fig. 6 – Checking Piston Pin

PISTON, RINGS AND CONNECTING ROD INSPECTION AND ASSEMBLY

2. Check piston pin bearing, Fig. 7.
 - a. **Replace** if greater than **17.98 mm (0.708")** or **.01 mm (.0004")** out of round.

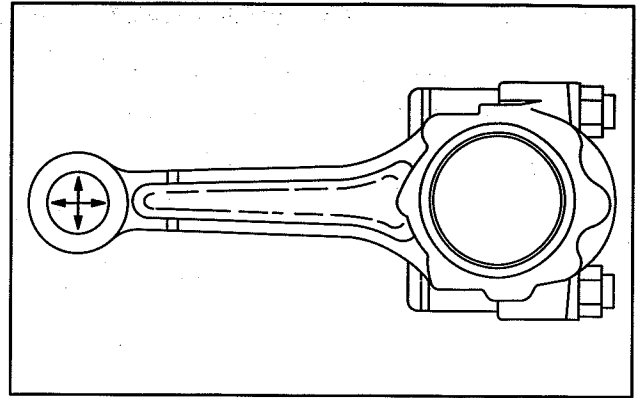

Fig. 7 – Checking Piston Pin Bearing

3. Check crankpin bearing end of connecting rod for out of round, Fig. 8.
 - a. With bearing inserts removed, assemble connecting rod cap and torque to 33.9 Nm (300 in. lbs.).

Maximum out of round: 0.02 mm (0.0008").

- b. If out of round exceeds specification shown, the connecting rod must be replaced.

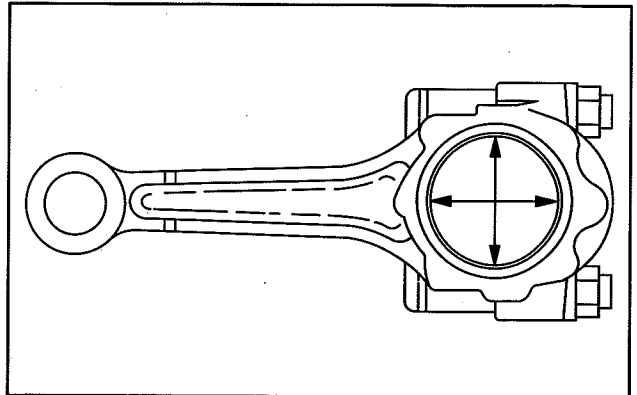

Fig. 8 – Checking Crankpin Bearing End

4. Check for bent or twisted connecting rod, Fig. 9.

Note: Thrust faces must be free of any burrs or nicks or connecting rod will not lay flat on surface plate.

- a. With connecting rod on a surface plate, any distortion will be evident by a rocking motion.
 - b. If a 0.05 mm (0.002") feeler gauge can be inserted at piston pin end of connecting rod the rod must be replaced.

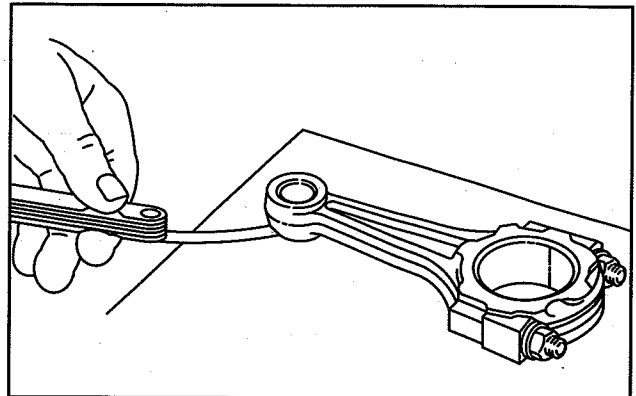

Fig. 9 – Checking Connecting Rod

ASSEMBLE PISTON AND CONNECTING ROD

Assemble piston to connecting rod using piston pin fixture, Tool #19419, Fig. 10.

Note: Arrow on piston and ID mark on rod must face same side.

1. Lubricate piston pin with engine oil. Then, insert threaded driver through piston pin and thread into pilot.
 - a. With arrow on piston and ID mark on rod facing up, insert pilot through piston and connecting rod.

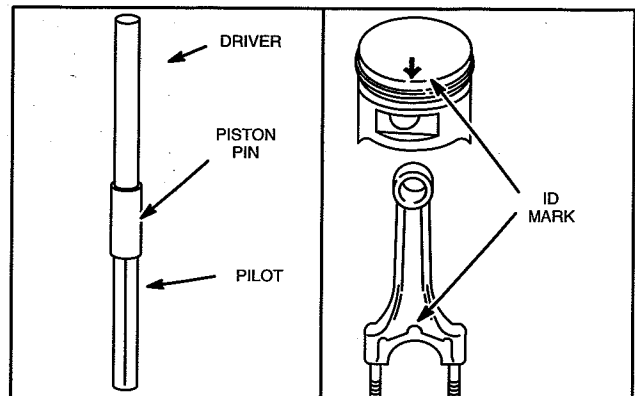

Fig. 10 – Assembling Piston And Rod

PISTON, RINGS AND CONNECTING ROD INSPECTION AND ASSEMBLY

2. Insert piston pin stop in bottom of piston support, Fig. 11.
 - a. With arrow on piston up, place assembly onto support.
 - b. Press in piston pin until pilot bottoms on stop.

After assembly, make sure piston rotates freely on connecting rod.

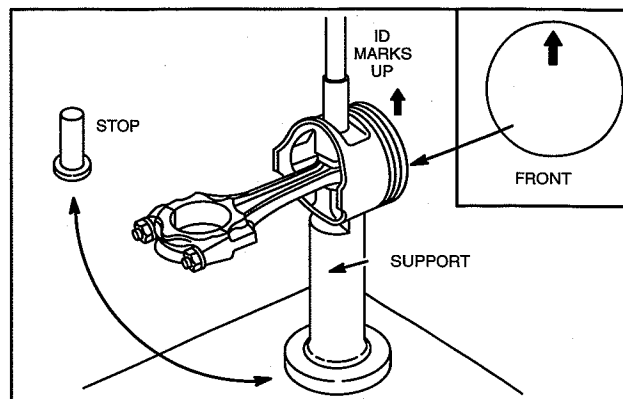

Fig. 11 – Installing Piston Pin

ASSEMBLE PISTON RINGS TO PISTON

1. Install oil ring expander first.
 - a. Spiral bottom oil control ring into top ring groove, center ring groove and then into position below expander, Fig. 12.
 - b. Repeat for upper oil control ring.

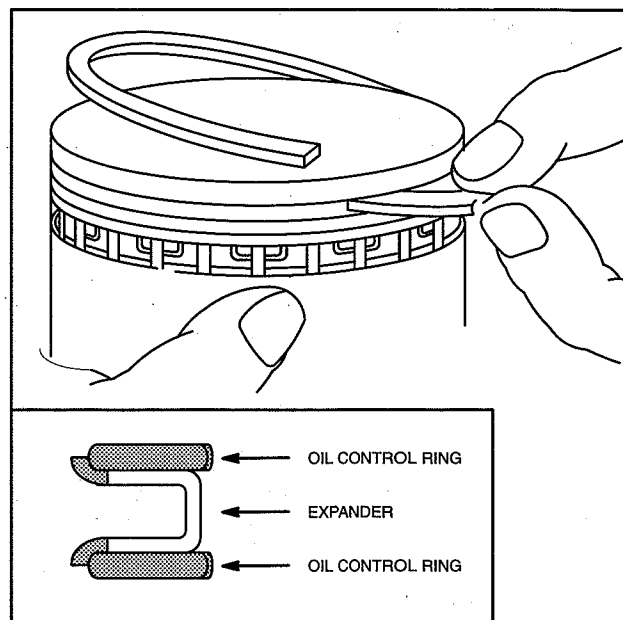

Fig. 12 – Installing Oil Ring

2. Using ring expander, Tool #19340, install center compression ring then, top compression ring with ID marks up, Fig. 13.
 - a. Stagger ring end gaps.
 - b. Rotate oil control ring ends 180° from each other.

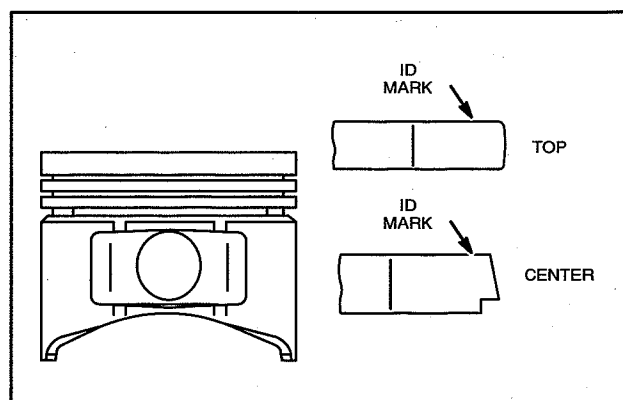

Fig. 13 – Installing Compression Rings

Section 9 Cylinder Block Assembly

Section Contents

	Page
INSTALL CRANKSHAFT	1
INSTALL PISTONS AND CONNECTING RODS	2
GENERAL ASSEMBLY	
Oil Pick-up Tube	3
Rear Seal Retainer and Starter Motor	3
Flywheel	3
INSTALL TIMING GEAR CASE, CAMSHAFT AND GEARS	4
INSTALL OIL PAN	6
INSTALL ALTERNATOR	6

INSTALL CRANKSHAFT

Install main bearings in cylinder block, Fig. 1.

Note: Upper bearing has an oil groove and oil holes.

1. Install upper main bearings in their respective saddles.
 - a. Be sure bearing is seated in saddle and tang in bearing is aligned with notch in saddle.
 - b. Lubricate bearings with engine oil.
2. Install lower main bearings in bearing caps, Fig. 2.
 - a. Be sure bearing is seated in bearing cap and tang in bearing is aligned with notch in bearing cap.
 - b. Lubricate bearings with engine oil.

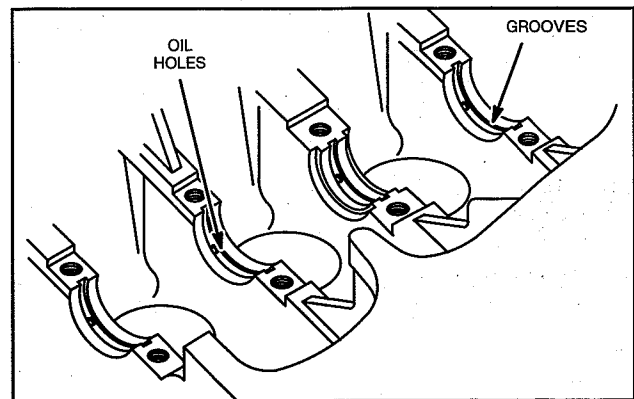

Fig. 1 – Installing Upper Main Bearings

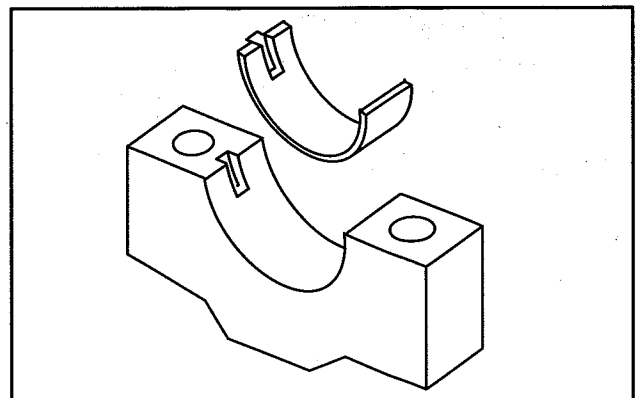

Fig. 2 – Installing Lower Main Bearings

CYLINDER BLOCK ASSEMBLY

3. Install crankshaft with gear facing front of cylinder block, Fig. 3. Take care not to damage journals or bearings.
 - a. Install crankshaft shims on #3 main bearing web with grooves facing out.
 - b. Lubricate journals with engine oil.

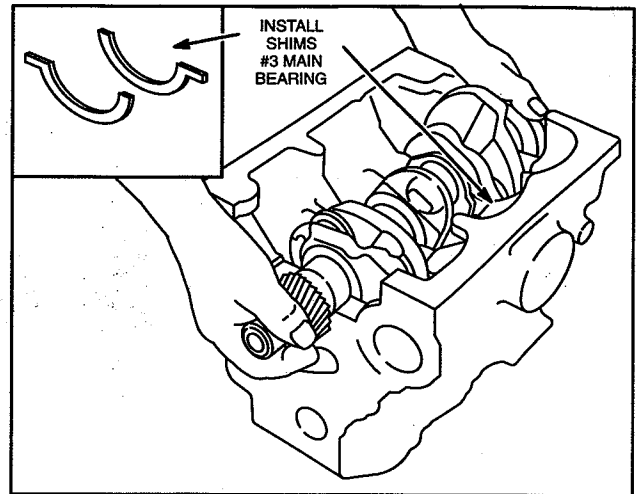

Fig. 3 - Installing Crankshaft

4. Install main bearing caps, Fig. 4. Lubricate threads of screws with engine oil.
 - a. Install bearing caps in their respective positions with arrows facing front.
 - b. Starting with #3 bearing cap, torque bearing caps one at a time in sequence shown to 61.0 Nm (45 ft. lbs.).
 - c. Recheck crankshaft end play.

Crankshaft End Play:
0.025 - 0.23 mm (0.001 - 0.009")

Note: After torquing bearing cap, make sure crankshaft rotates freely before proceeding to next bearing cap.

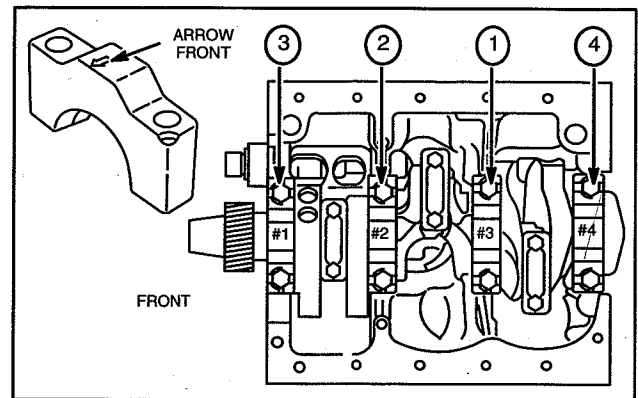

Fig. 4 - Installing Main Bearing Caps

9

INSTALL PISTONS AND CONNECTING RODS

1. Install connecting rod bearings, Fig. 5. Be sure tang on bearing is seated in notch in connecting rod and cap.
 - a. Install a piece of vinyl tubing over each connecting rod screw to prevent damage to screw threads or crankpin when installing piston and connecting rod.

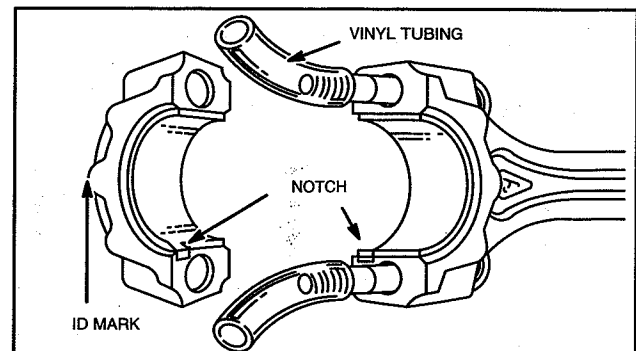

Fig. 5 - Installing Connecting Rod Bearings

CYLINDER BLOCK ASSEMBLY

Rotate crankshaft so that crankpin is at bottom of stroke. Then, lubricate cylinder walls, piston and rings, bearings and crankpins.

2. Using ring compressor, Tool #19070, install piston and connecting rod assemblies with arrow on piston facing front, Fig. 6.
 - a. Install connecting rod cap with ID mark facing front. Lubricate threads and torque nuts to 36.0 Nm (320 in. lbs.).

Note: After torquing rod cap, make sure crankshaft rotates freely before proceeding to next cylinder.

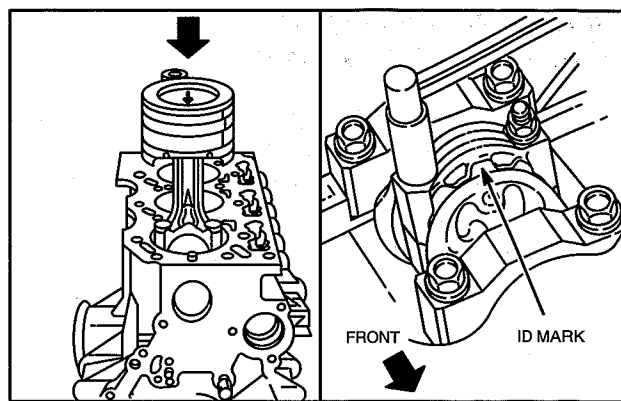

Fig. 6 – Installing Piston And Connecting Rod

GENERAL ASSEMBLY

1. Install gasket, oil pick-up tube and strainer, Fig. 7.
 - a. Torque screws to 8.0 Nm (70 in. lbs.).

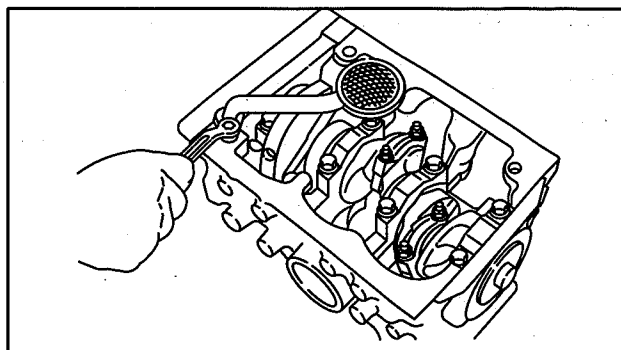

Fig. 7 – Installing Oil Pick Up

2. Install gasket and rear seal retainer, Fig. 8.
 - a. Torque screws to 6.0 Nm (50 in. lbs.).
3. Install starter motor.
 - a. Torque screws to 40.0 Nm (30 ft. lbs.).

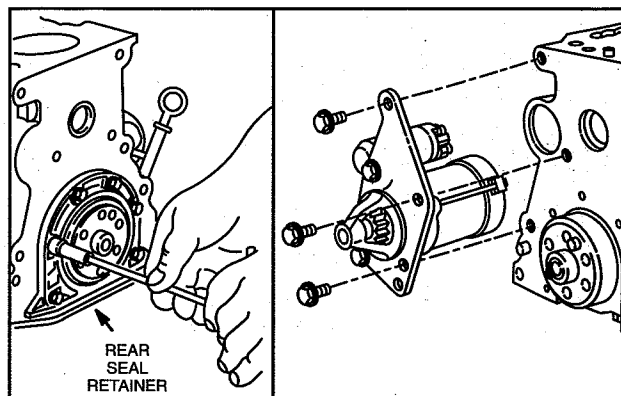

Fig. 8 – Installing Rear Seal Retainer

4. Install flywheel, Fig. 9.
 - a. Install flywheel holder, Tool #19418.
 - b. Apply Permatex® No. 2 or similar sealant to flywheel screws and torque to 47.0 Nm (35 ft. lbs.).

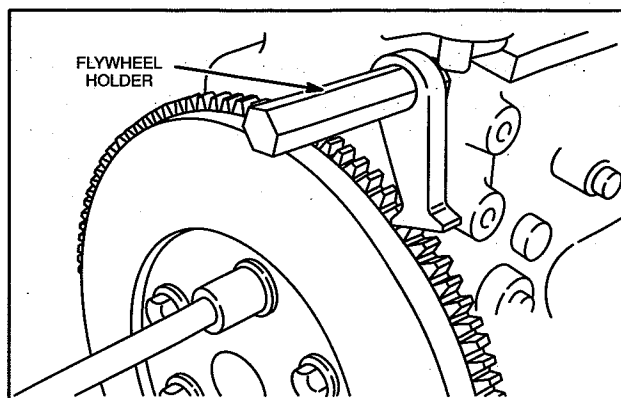

Fig. 9 – Installing Flywheel

CYLINDER BLOCK ASSEMBLY

INSTALL TIMING GEAR CASE, CAMSHAFT AND GEARS

1. Lubricate oil pump rotor with engine oil and install in cylinder block, Fig. 10.
 - a. ID mark on rotor must face cylinder block.

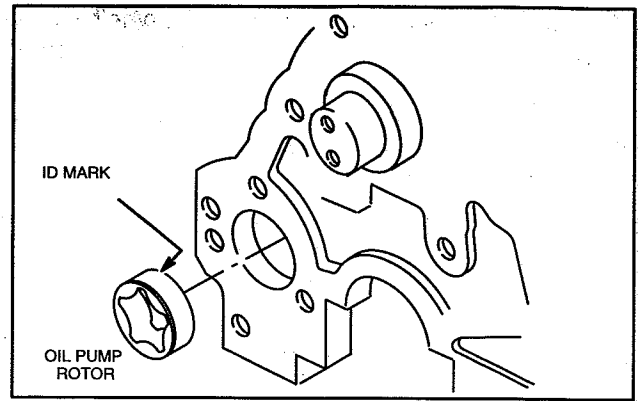

Fig. 10 – Installing Oil Pump Rotor

2. Install timing gear case with new gasket.

Note: It may be necessary to rotate oil pump drive to engage oil pump rotors.

Note position, length and number of screws as shown, Fig. 11.

- a. M6 x 28 mm (M6 x 1.1"): 4
- b. M6 x 16 mm (M6 x 1.5"): 1

Torque screws to 8.0 Nm (70 in. lbs.).

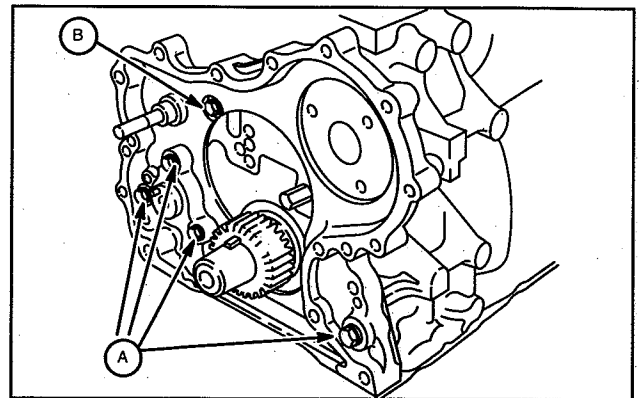

Fig. 11 – Installing Gear Case

3. Lubricate, then install camshaft in cylinder block, Fig. 12. Take care not to damage lobes or cam bearing.

- a. Install camshaft retainer.
- b. M6 x 18 mm (M6 x 0.7"): 3

Torque screws to 8.0 Nm (70 in. lbs.).

Note: Position camshaft retainer so that center hole does not interfere with camshaft.

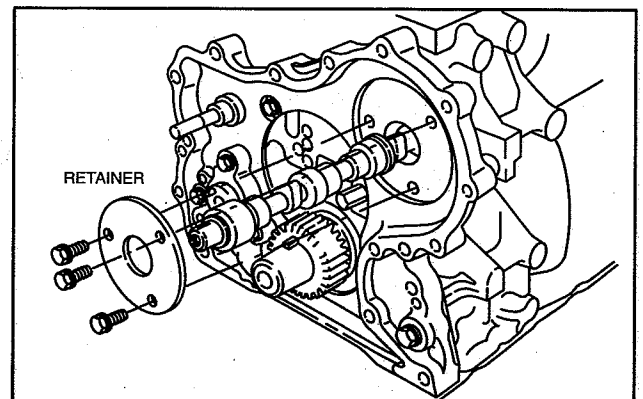

Fig. 12 – Installing Camshaft

4. Rotate crankshaft so that crankshaft key is at 12 o'clock position as shown in Fig. 13.

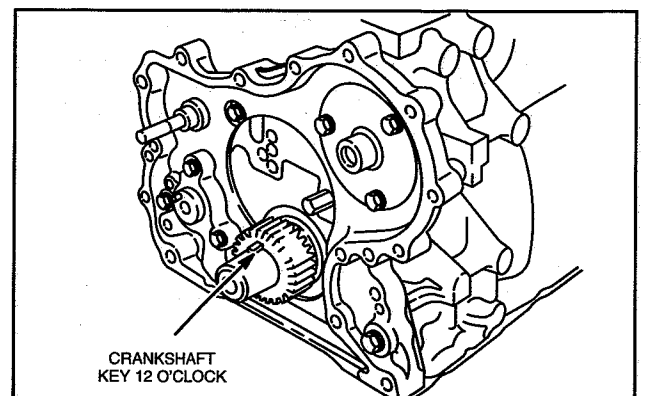

Fig. 13 – Rotate Crankshaft

5. Assemble idler gear shaft with ID mark up, as shown in Fig. 14.

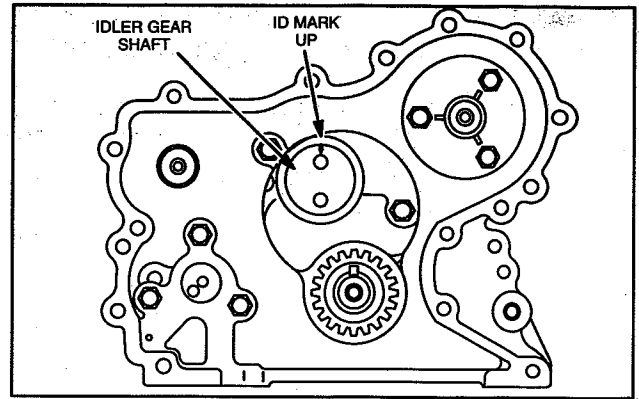

Fig. 14 – Assemble Idler Gear Shaft

Engine models 430000 and 580000 after date code 990111007 are equipped with right angle helical timing gears. Timing marks are identified by letters (A, AA, B, BB, etc.), instead of numbers. The timing procedure is the same.

6. With crankshaft key at 12 o'clock position, assemble idler gear so that timing mark 11 (AA) is aligned with timing mark 1 (A) on crankshaft gear, timing mark 22 (BB) is aligned with timing mark 2 (B) on camshaft gear as shown in Fig. 15.

- a. Install oil pump gear.
- b. Install governor gear.

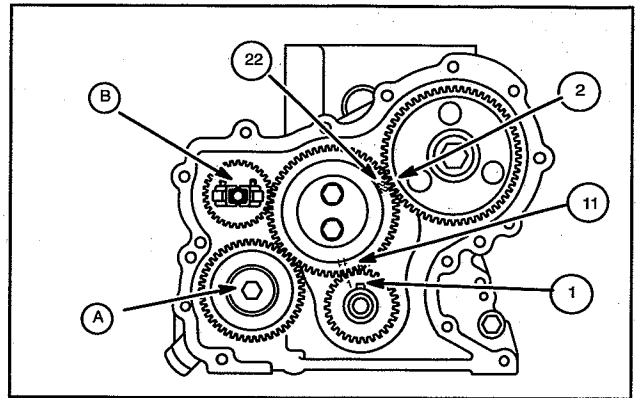

Fig. 15 – Aligning Timing Marks

7. Torque screws as shown, Fig. 16.

- a. Camshaft gear: 41.0 Nm (30 ft. lbs.).
- b. Idler gear: 25.0 Nm (220 in. lbs.).
- c. Oil pump gear: 19.0 Nm (170 in. lbs.).

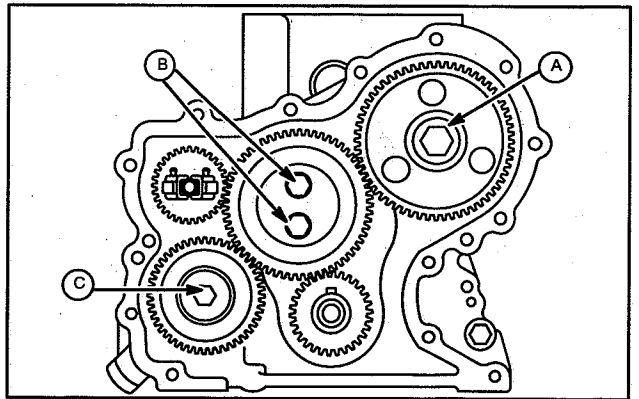

Fig. 16 – Torque Screws

8. Install timing gear cover with new gasket. Note position, length and number of screws as shown, Fig. 17.

- a. M6 x 65 mm (M6 x 2.5"): 2
- b. M6 x 55 mm (M6 x 2.1"): 3
- c. M6 x 30 mm (M6 x 1.1"): 7
- d. M6 Nuts: 2

Torque screws and nuts to 8.0 Nm (70 in. lbs.).

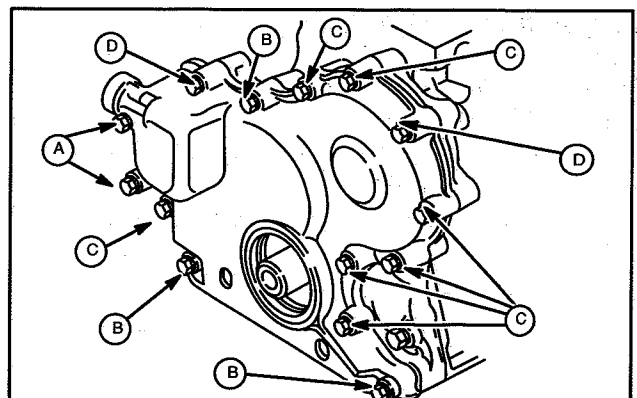

Fig. 17 – Installing Timing Cover

CYLINDER BLOCK ASSEMBLY

9. Install crankshaft pulley with timing mark at 12 o'clock position (#1 cylinder), Fig. 18.

Note: Be sure alignment pin in crankshaft gear is seated in hole in pulley.

- a. Torque screw to 88.0 Nm (65 ft. lbs.).
- b. Remove flywheel holder.
- c. Install trigger assembly and wire.

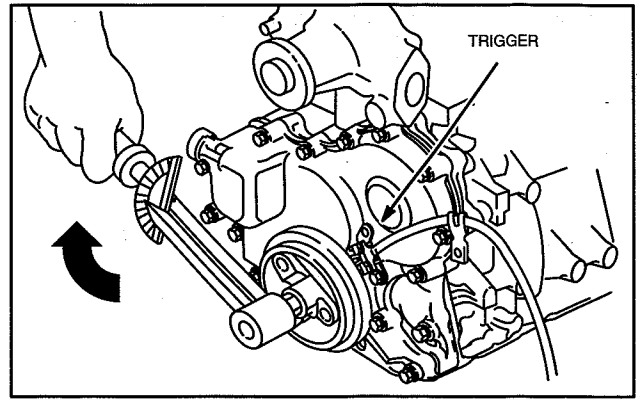

Fig. 18 – Installing Pulley

INSTALL OIL PAN

1. Install oil pan with new gasket, Fig. 19.
 - a. Apply a small bead of Permatex® No. 2 or similar sealant to crankcase areas shown.
 - b. Torque screws and nuts to 8.0 Nm (70 in. lbs.).

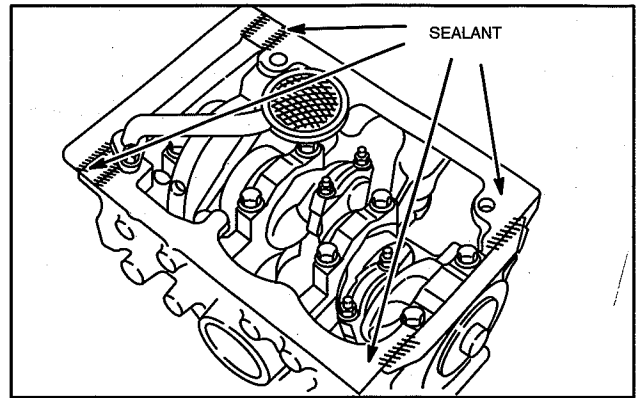

Fig. 19 – Installing Oil Pan

INSTALL ALTERNATOR

1. Install alternator bracket and alternator, Fig. 20.
 - a. Torque screws to 19.0 Nm (170 in. lbs.).

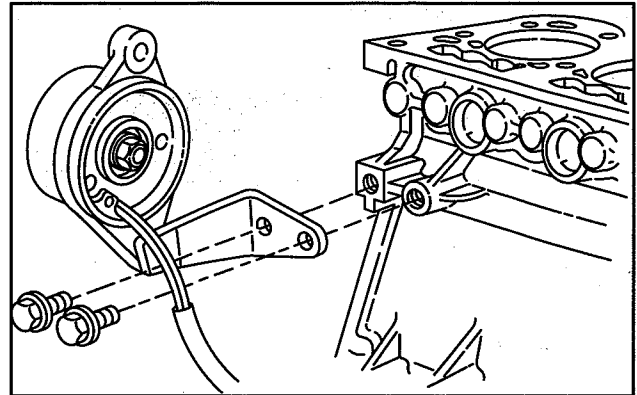
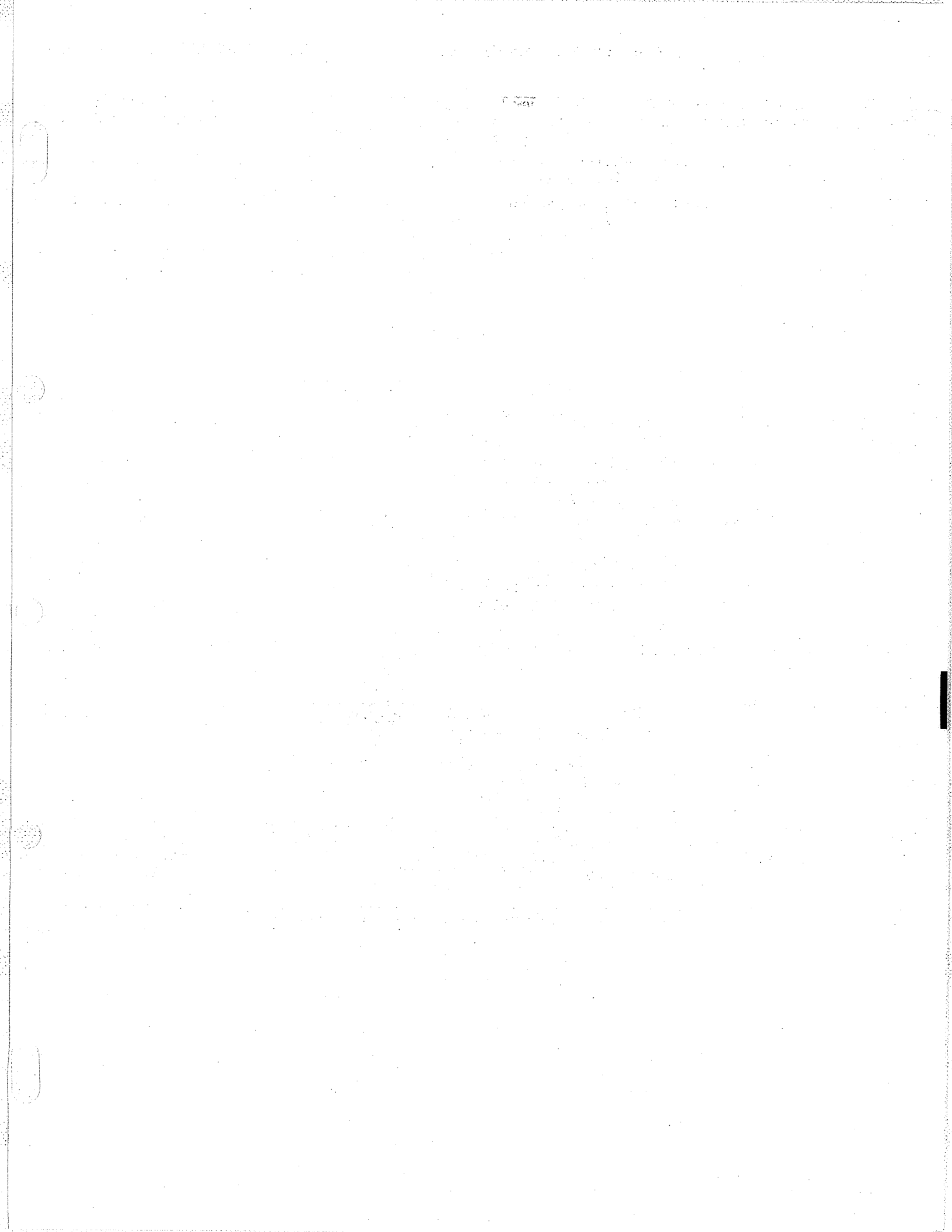
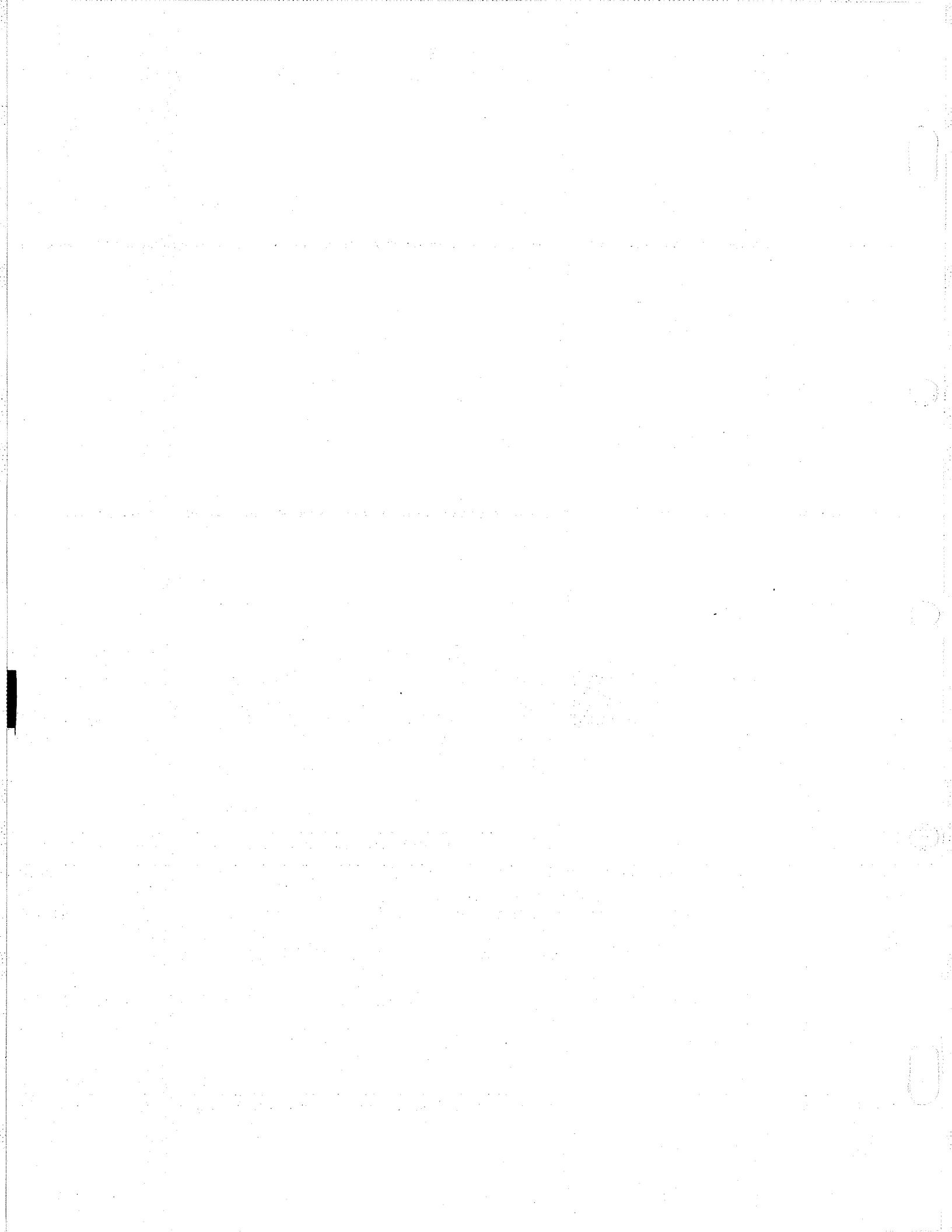

Fig. 20 – Install Alternator

GENERAL ASSEMBLY

1. Lubricate tappets with engine oil and install in cylinder block.
2. See Section 2 for installation of cylinder head and related components.
3. See Section 3 for governor adjustment procedure.





Section 10

Carburetor And Related Components

Section Contents

	Page
MANUAL CHOKE CARBURETOR	
REMOVE CARBURETOR	3
DISASSEMBLE CARBURETOR	4
CLEAN AND INSPECT CARBURETOR	6
CHECK THROTTLE, CHOKE SHAFT AND BODY FOR WEAR	6
ASSEMBLE CARBURETOR	7
INSTALL CARBURETOR	8
CARBURETOR ADJUSTMENT	9
AUTOMATIC CHOKE CARBURETOR	10
REMOVE CARBURETOR	11
DISASSEMBLE CARBURETOR	11
CLEAN AND INSPECT CARBURETOR	14
CHECK THROTTLE, CHOKE SHAFT AND BODY FOR WEAR	14
ASSEMBLE CARBURETOR	15
CHECKING VACUUM CHOKE BREAK	17
ADJUSTING CHOKE PRE-LOAD LEVER	18
CHECKING P.T.C. HEATER	18
INSTALL CARBURETOR	18
INSTALL VACUUM LIMITER	18
CARBURETOR ADJUSTMENT	19
FUEL PUMP SPECIFICATIONS	20
CHECKING FUEL PUMP OUTPUT	21
TESTING FUEL PUMP WIRING	21
ANTI-AFTERFIRE SOLENOID	22
TESTING ANTI-AFTERFIRE SOLENOID	22
TESTING EQUIPMENT SOLENOID WIRING	22
TESTING SOLENOID	23
FUEL FILTER	23
MAIN JET IDENTIFICATION	23

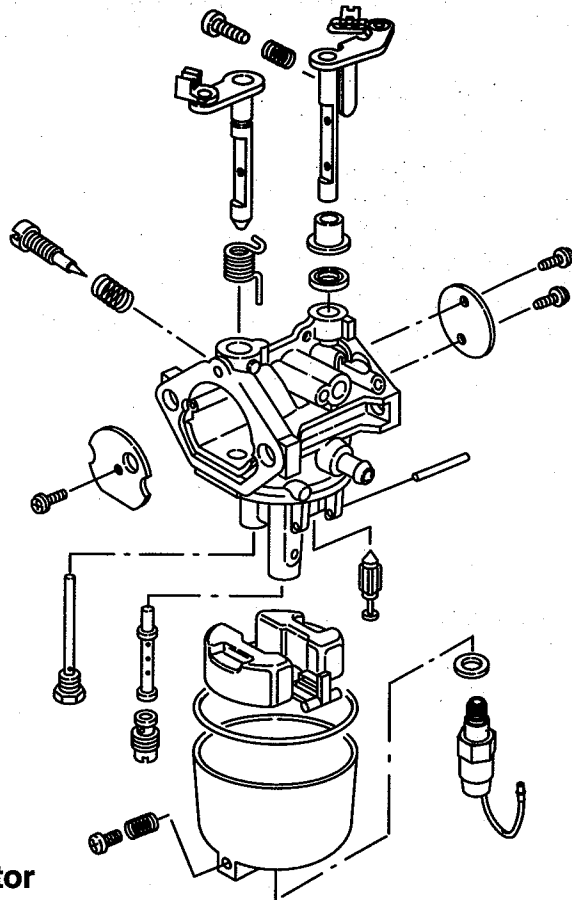

Manual Choke Carburetor

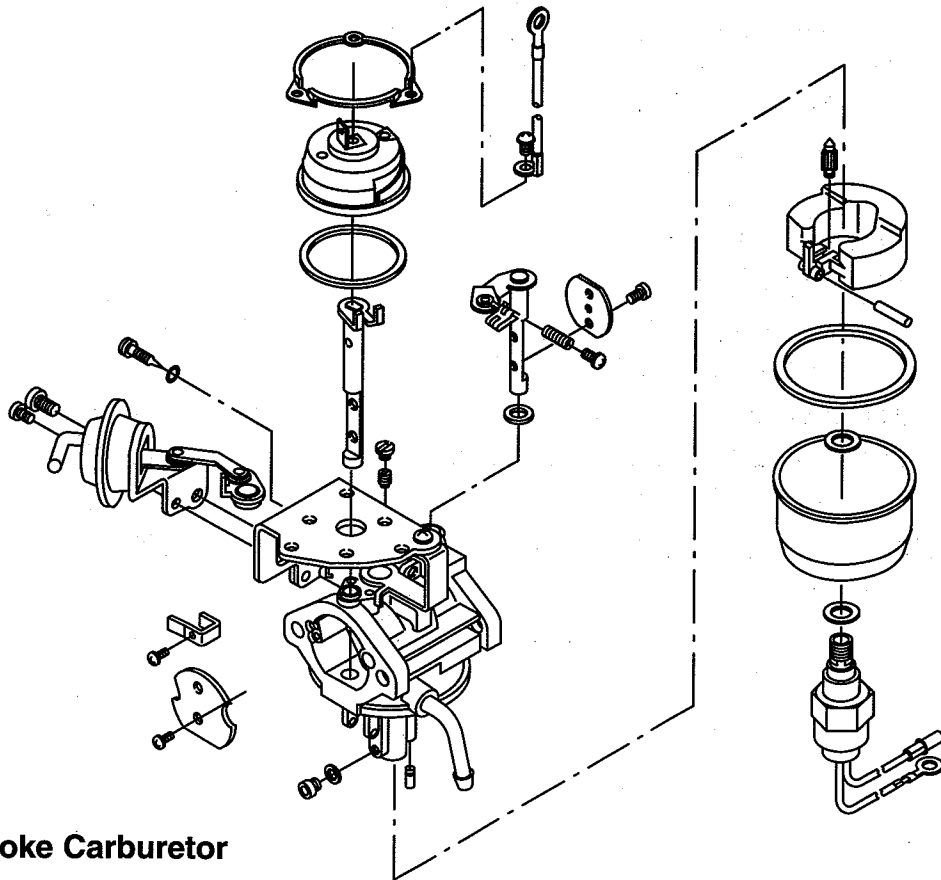

Automatic Choke Carburetor

**MANUAL CHOKE CARBURETOR
REMOVE CARBURETOR**

Disconnect fuel line. Remove air cleaner tube from carburetor air horn. Disconnect fuel solenoid wire, if equipped.

1. Unhook governor link spring from throttle lever and disconnect governor link, Fig. 1.
 - a. Disconnect choke link at choke lever. Proceed to Step 4.

Note: Early style choke links were manufactured with a "Z" bend, Fig. 3. To remove choke link the governor control bracket must be removed. Proceed to Steps 2 and 3.

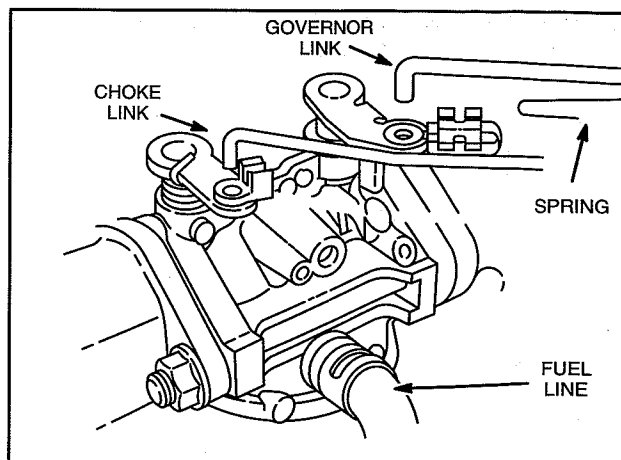

Fig. 1 – Remove Governor And Choke Link

2. Disconnect governor spring. Remove two screws and governor control bracket from intake manifold, Fig. 2.

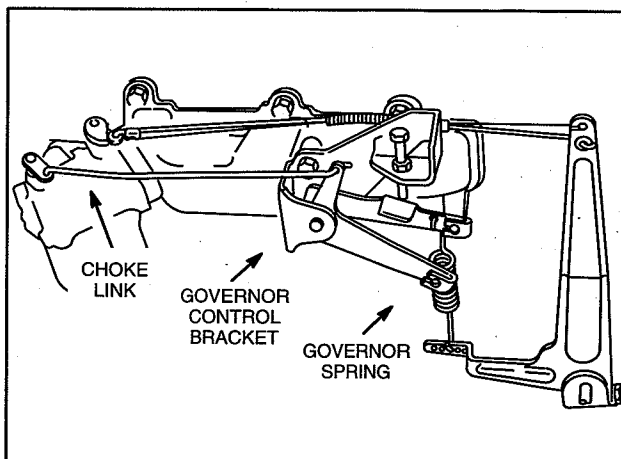

Fig. 2 – Removing Governor Control Bracket

3. Remove choke link from choke lever, Fig. 3.

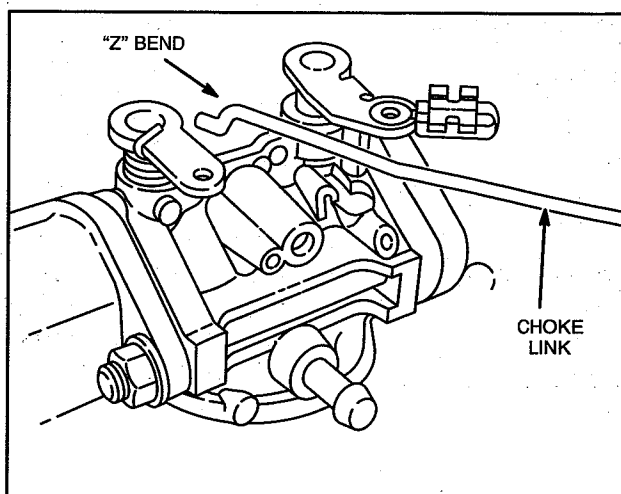

Fig. 3 – Removing Choke Link – Early Style

CARBURETOR AND RELATED COMPONENTS

4. Remove nuts, air horn, carburetor and insulator, Fig. 4. Discard gaskets.

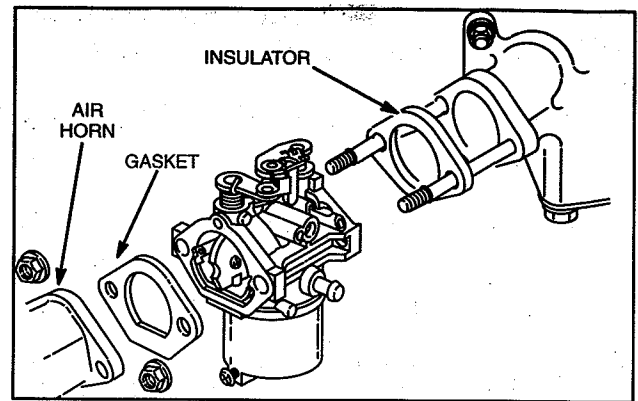

Fig. 4 – Removing Carburetor

DISASSEMBLE CARBURETOR

1. Remove anti-afterfire solenoid or bowl screw, washer and carburetor bowl, Fig. 5.

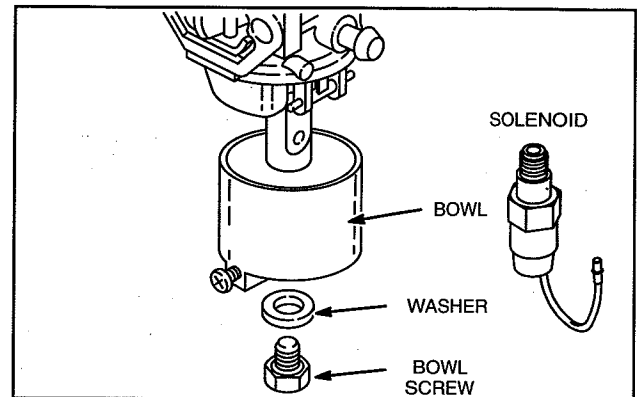

Fig. 5 – Removing Bowl

2. Drive out float hinge pin from choke plate side of carburetor with a small punch. Remove float and fuel inlet valve, Fig. 6.

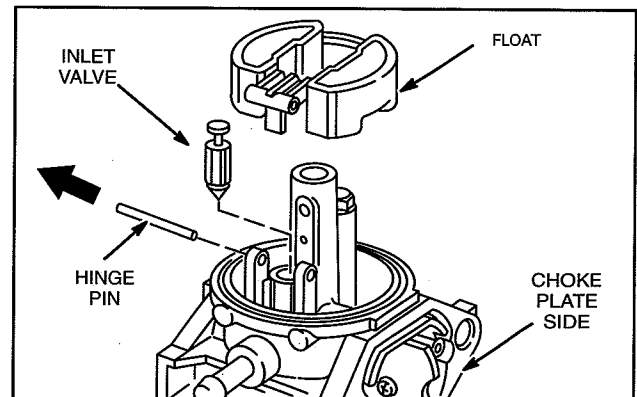

Fig. 6 – Removing Float

3. Remove carburetor bowl gasket, Fig. 7.

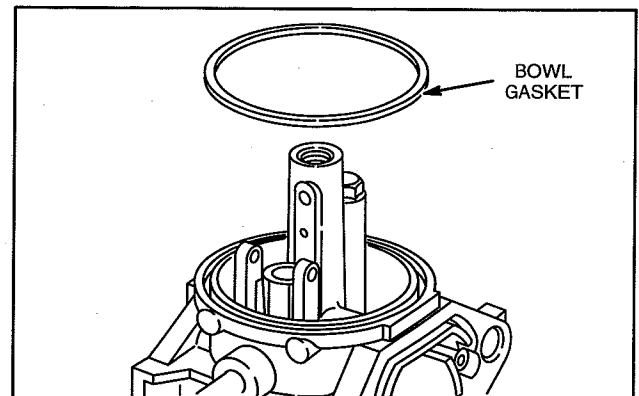

Fig. 7 – Removing Bowl Gasket

CARBURETOR AND RELATED COMPONENTS

4. Remove fixed high speed jet using screwdriver, Tool #19062, Fig. 8.
 - a. Remove emulsion tube.

Note: Consult the illustrated parts list for correct part number for special high altitude jet, if required. Also, See page 23 for main jet identification chart.

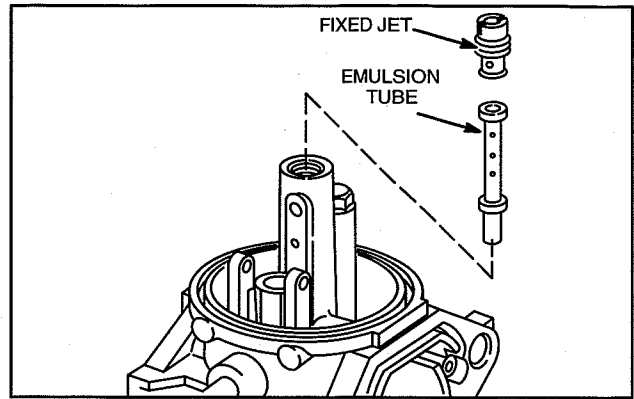

Fig. 8 – Removing High Speed Jet And Nozzle

5. Remove idle jet, Fig. 9.

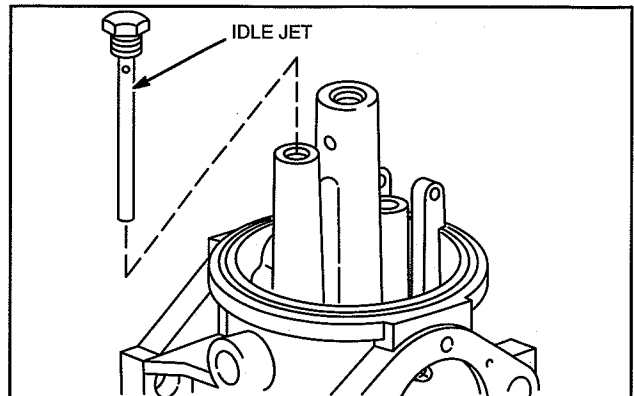

Fig. 9 – Removing Idle Jet

6. If idle mixture screw is equipped with adjustment limiter cap, use a pliers to remove it before removing idle mixture valve.
 - a. Remove Idle mixture screw and spring, Fig. 10.

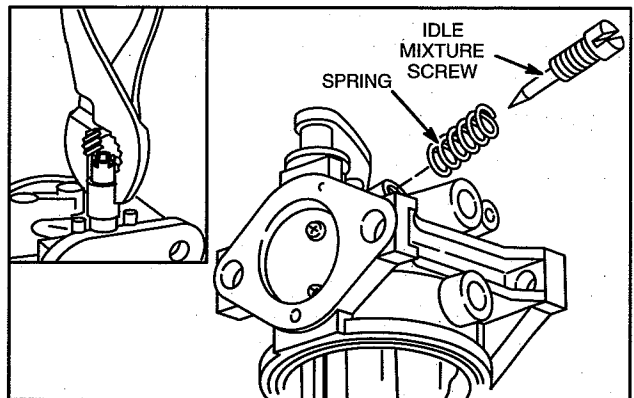

Fig. 10 – Removing Idle Mixture Screw

7. Remove screw and choke plate.
 - a. Remove choke shaft and spring, Fig. 11.

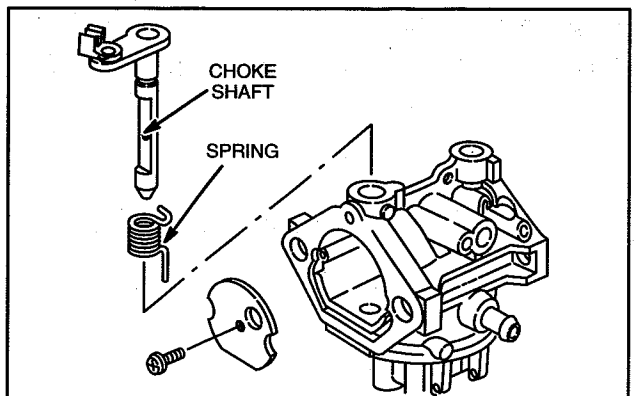

Fig. 11 – Removing Choke Shaft

CARBURETOR AND RELATED COMPONENTS

Note: If engine is equipped with electronic governor system, DO NOT remove throttle plate or throttle shaft. This is a precision assembly and should not be disassembled.

If engine is not equipped with electronic governor proceed to step 8.

8. Mark throttle plate before removing so that it may be re-installed in the same position. Sides of throttle plate are beveled.
9. Remove two screws, throttle plate, throttle shaft with collar and seal, Fig. 12.
 - a. Discard seal.

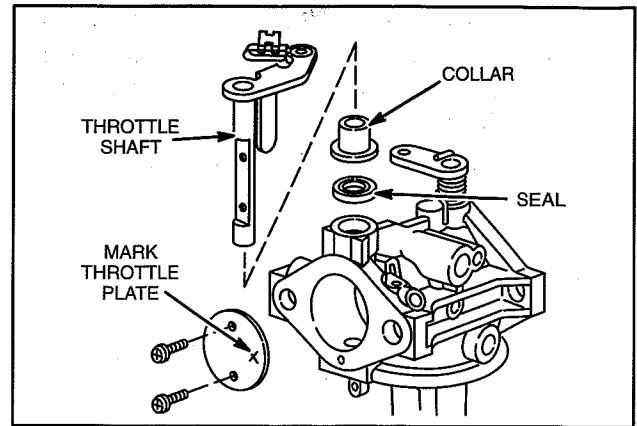

Fig. 12 – Removing Throttle Shaft

CLEAN CARBURETOR

Remove gasket material from mounting surfaces. Gummy or dirty carburetors should be cleaned in a carburetor cleaner. DO NOT soak rubber, neoprene or plastic parts in cleaner.

IMPORTANT: If engine is equipped with electronic governor system, DO NOT clean carburetor in carburetor cleaner. The carburetor is equipped with sealed ball bearings for the throttle shaft, which will be damaged if carburetor is immersed in carburetor cleaner. Ball bearings are not replaceable.

INSPECT CARBURETOR

Inspect all parts for wear, cracks, nicks and burrs. Inspect float for leaks. Replace all damaged parts.

CHECK THROTTLE, CHOKE SHAFT AND BODY FOR WEAR

1. Lay carburetor on flat surface and check throttle and choke shaft clearance as shown in Fig. 13.

Throttle shaft and choke shaft clearance must not exceed .25 mm (.010").

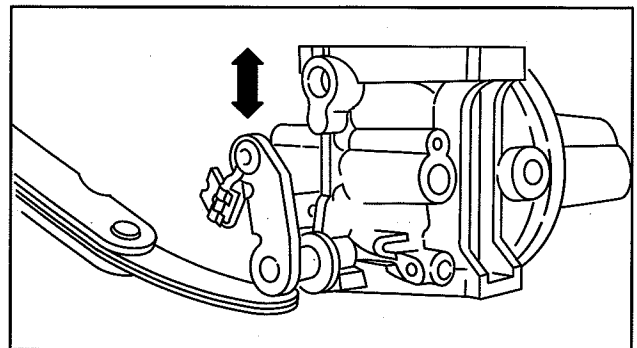

Fig. 13 – Checking Clearance

2. Inspect throttle shaft and choke shaft for wear, Fig. 14.

Replace if worn.

If carburetor body is worn, replace carburetor.

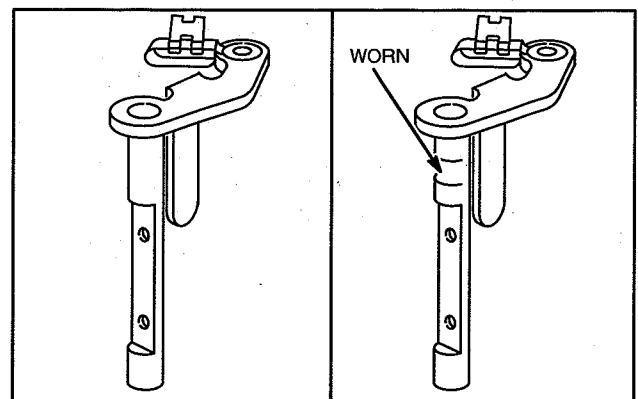

Fig. 14 – Checking Throttle Shaft Wear

CARBURETOR AND RELATED COMPONENTS

ASSEMBLE CARBURETOR

When assembling carburetor, use new seals and gaskets.

1. Install throttle shaft, Fig. 15.
 - a. Install seal with grooved side out.
 - b. Assemble collar to throttle shaft and insert in body.
 - c. Install throttle plate and screws.

Note: Use LOCTITE® 222 on screw threads.

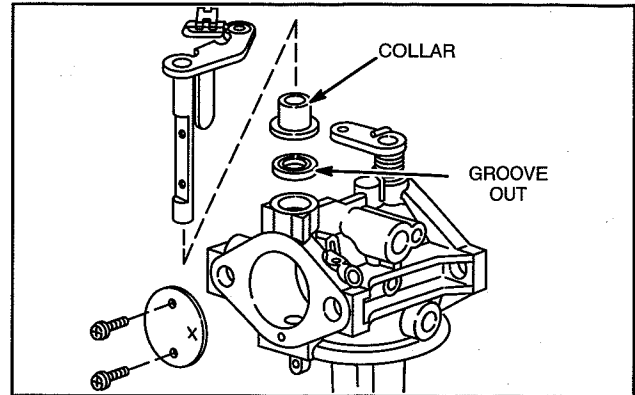

Fig. 15 – Installing Throttle Shaft

2. Install choke valve, Fig. 16.
 - a. Assemble spring to choke shaft and insert in body.
 - b. Rotate shaft clockwise to pre-load spring.
 - c. Install choke plate with hole facing fuel inlet side of body.

Note: Use LOCTITE® 222 on screw threads.

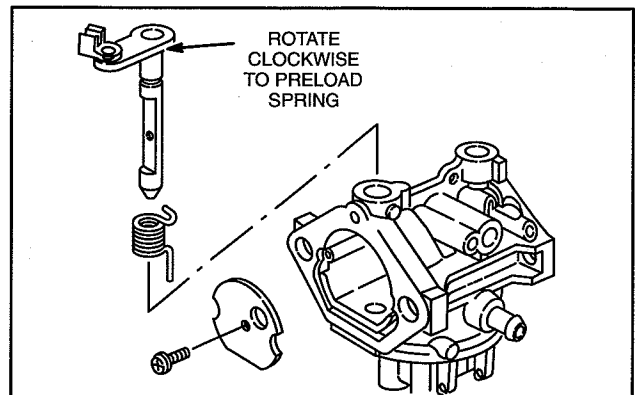

Fig. 16 – Installing Choke Shaft

3. Assemble the following parts, Fig. 17:
 - a. Emulsion tube.
 - b. Fixed high speed jet using screwdriver, Tool #19062
 - c. Idle jet.

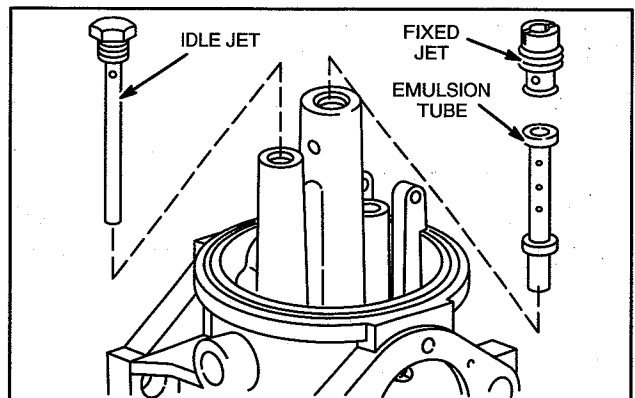

Fig. 17 – Installing Nozzle And Jets

4. Install float, Fig. 18.
 - a. Assemble inlet valve to float.
 - b. Install float hinge pin from throttle plate side of carburetor.

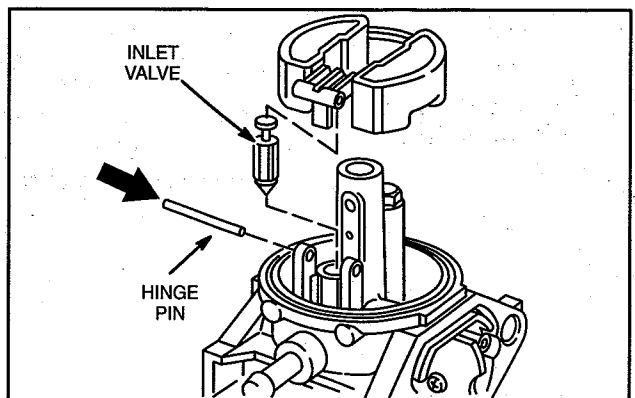

Fig. 18 – Install Float

CARBURETOR AND RELATED COMPONENTS

5. Install gasket and float bowl, Fig. 19.

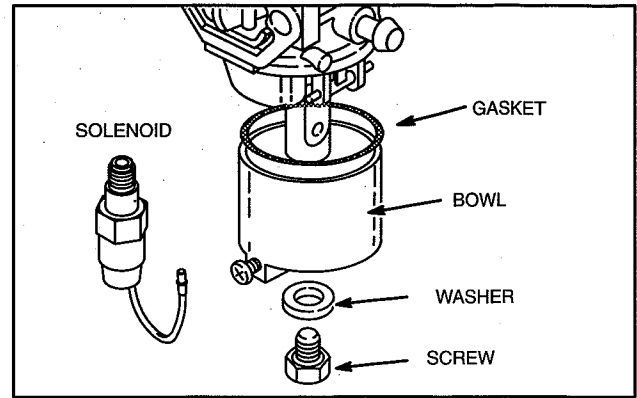

Fig. 19 – Install Float Bowl

6. Install idle mixture screw and spring, Fig. 20.
DO NOT tighten idle mixture screw.

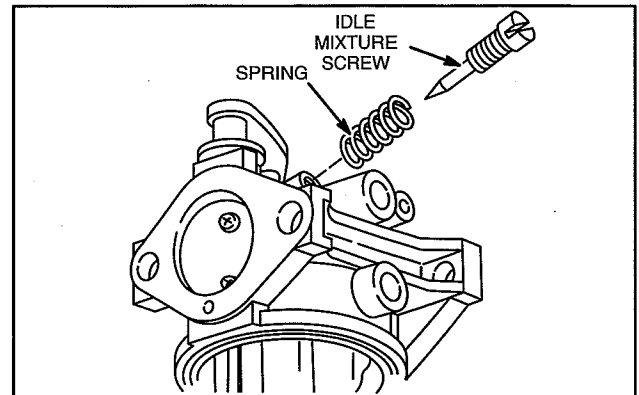

Fig. 20 – Install Idle Mixture Screw

INSTALL CARBURETOR

1. Assemble insulator with gaskets, carburetor and air horn with gasket to intake manifold, Fig. 21.

Torque nuts to 8.0 Nm (70 in. lbs.).

- a. Install governor link and spring.
- b. Install choke link.

Note: Proceed to Step 2 if choke link is early style with "Z" bend.

Reinstall air cleaner tube and fuel line.

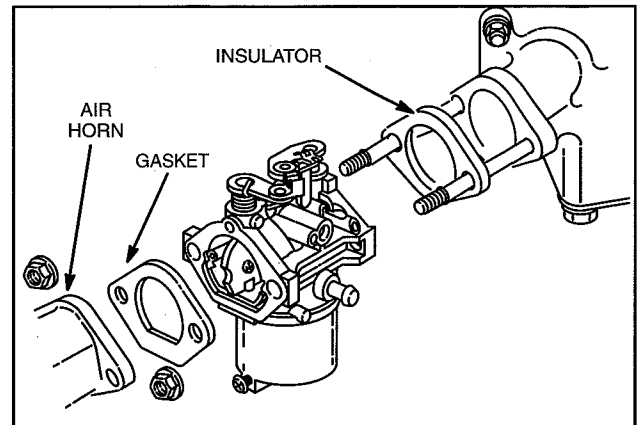

Fig. 21 – Install Carburetor

2. Install choke link.

- a. Assemble governor control bracket to intake manifold, Fig. 22.

Torque screws to 8.0 Nm (70 in. lbs.).

- b. Assemble governor spring to governor control lever.

Important: Governor spring must be installed in correct hole in governor control lever by engine model.

- a. Model 430400 – Top Hole
- b. Model 580400 – Bottom Hole

Reinstall air cleaner tube and fuel line.

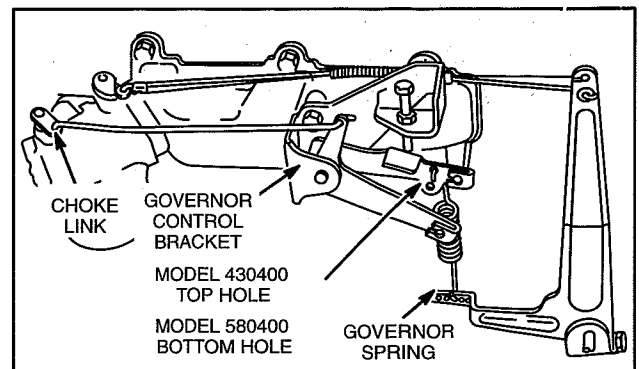

Fig. 22 – Install Governor Control Lever

CARBURETOR AND RELATED COMPONENTS

INITIAL CARBURETOR ADJUSTMENT

Turn idle mixture screw clockwise until it just seats. DO NOT FORCE. Turn screw counter-clockwise 1/2 turn, Fig. 23. This setting will permit engine to start.

Final adjustment will be made with engine running.

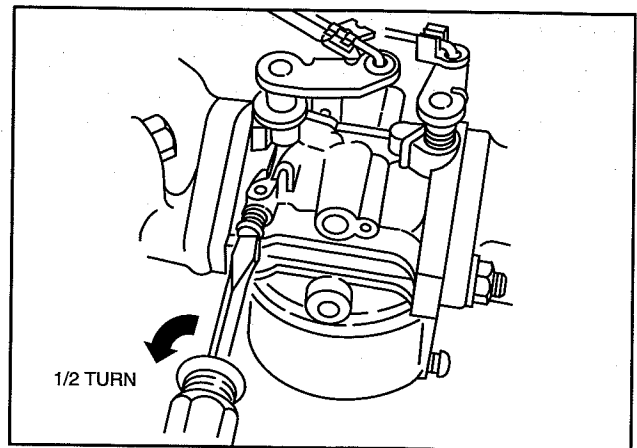

Fig. 23 – Initial Carburetor Adjustment

FINAL CARBURETOR ADJUSTMENT

ALL CARBURETOR ADJUSTMENTS MUST BE MADE WITH THE AIR CLEANER INSTALLED.

Start and run engine at low speed for approximately five minutes. Or, if equipped with temperature gauge, until needle moves from C or COLD position.

1. With control lever on equipment in SLOW position, hold throttle lever against idle speed screw and adjust idle speed to 1200 RPM, Fig. 24.

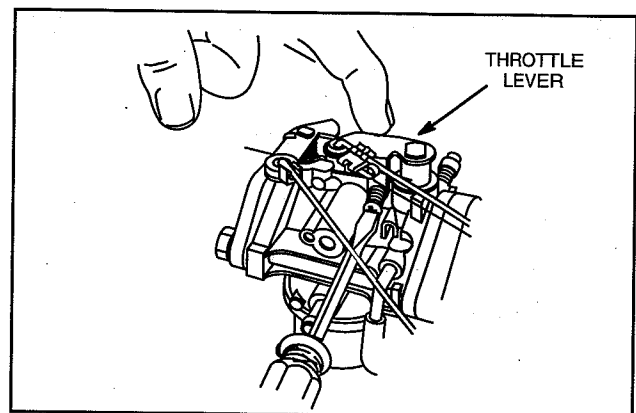

Fig. 24 – Adjusting Idle Speed

2. SLOWLY turn idle mixture screw clockwise until engine speed just starts to slow (lean mixture).
3. Then SLOWLY turn idle mixture screw counter-clockwise until engine speed just starts to slow (rich mixture).
4. Turn idle mixture screw to mid point between rich and lean, Fig. 25.
5. Hold throttle lever against idle speed screw and re-adjust idle speed to 1500 RPM, or equipment manufacturers specification.
6. IF CARBURETOR IS EQUIPPED WITH AN IDLE MIXTURE LIMITER CAP, INSTALL AT THIS TIME.

- a. Position limiter cap so that stop(s) on limiter cap are at mid point between stop(s) on carburetor body and press into position as shown in Fig. 25.

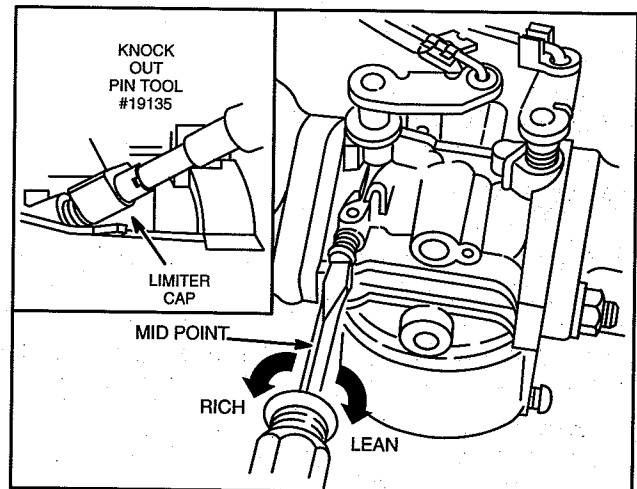

Fig. 25 – Adjusting Idle Mixture

CARBURETOR AND RELATED COMPONENTS

AUTOMATIC CHOKE CARBURETOR

The automatic choke consists of a vacuum choke break and a thermostat. Intake manifold vacuum activates the vacuum choke break which partially opens the choke plate, to prevent over chocking while the engine is being started. A vacuum limiter located in the vacuum line regulates vacuum to the vacuum choke break.

The thermostat contains a P.T.C. heater and a bi-metal spring which opens the choke plate gradually as the engine is running. When the keyswitch is turned "ON," battery current activates the P.T.C. heater which heats the bi-metal spring.

The P.T.C. Heater (an abbreviation of positive temperature coefficient heater), is a heat sensitive semiconductor porcelain. As the P.T.C. heater temperature rises, resistance increases, which regulates battery current to the heater and maintains the proper temperature for the bi-metal spring.

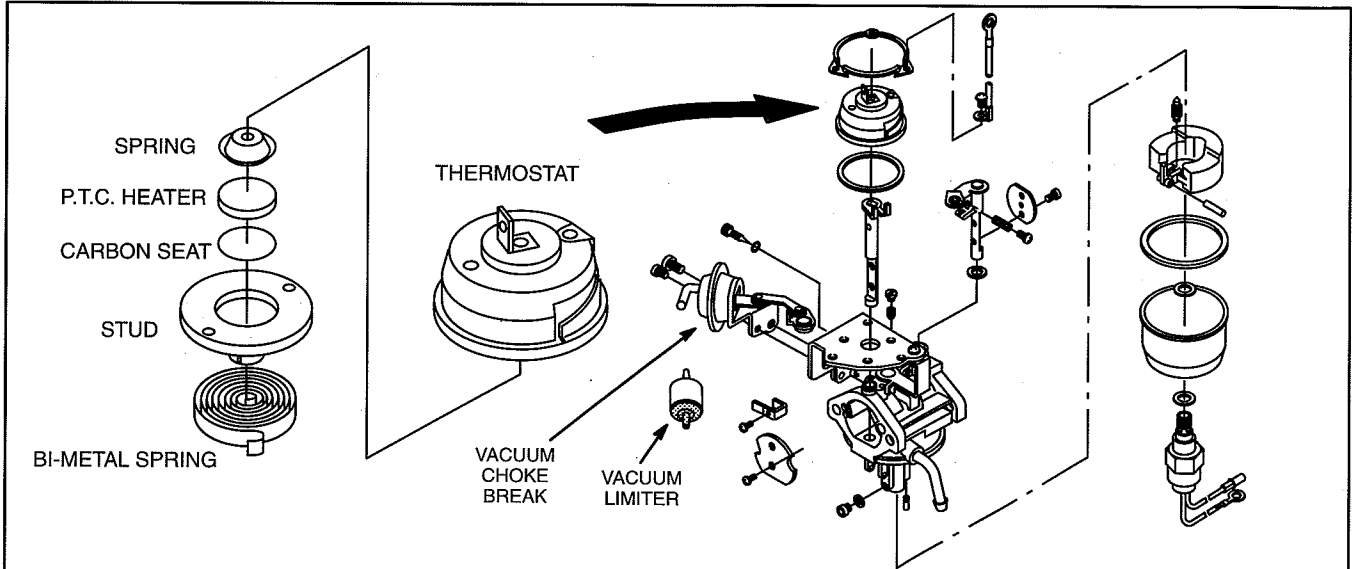

Wiring Diagram Standard

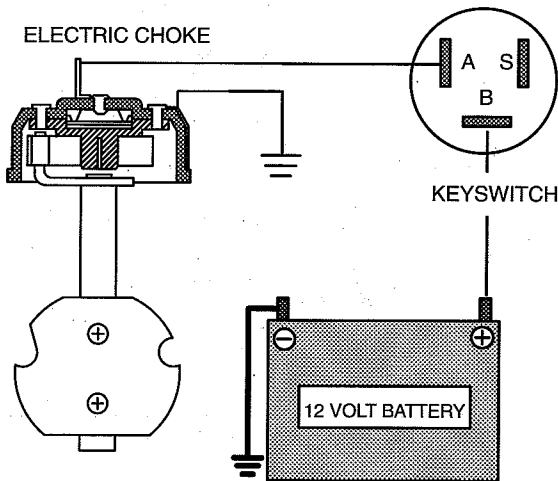

Wiring Diagram Optional

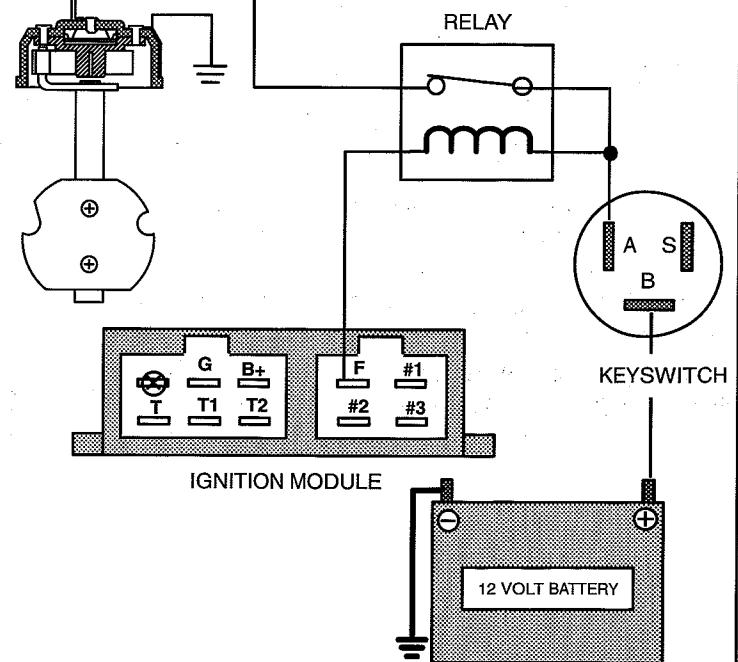

10

AUTOMATIC CHOKE CARBURETOR REMOVE CARBURETOR

Disconnect fuel line and remove air cleaner tube from carburetor air horn. Disconnect vacuum line from vacuum choke break. Disconnect wires from fuel shut off solenoid and automatic choke.

1. Unhook governor link spring from throttle lever and disconnect governor link, Fig. 26.

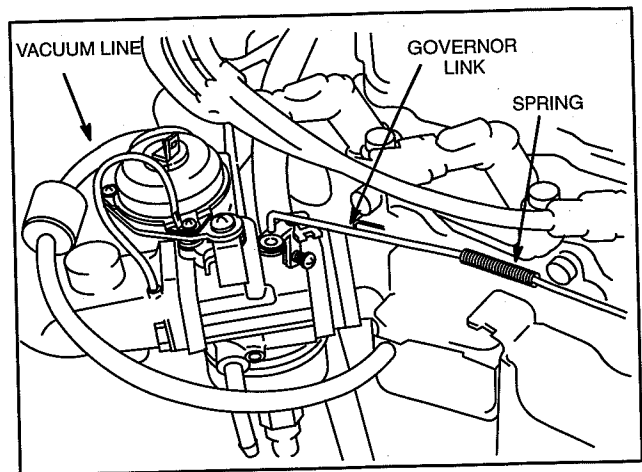

Fig. 26 – Remove Governor Link And Spring

2. Remove two nuts and ground wire from solenoid, air horn, carburetor and insulator, Fig. 27. Discard gaskets.

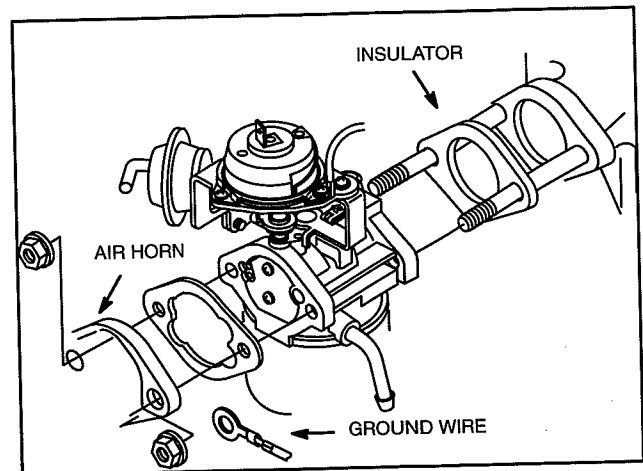

Fig. 27 – Removing Carburetor

DISASSEMBLE CARBURETOR

1. Remove fuel shut off solenoid and gasket. Remove float bowl and bowl shim gasket, Fig. 28.

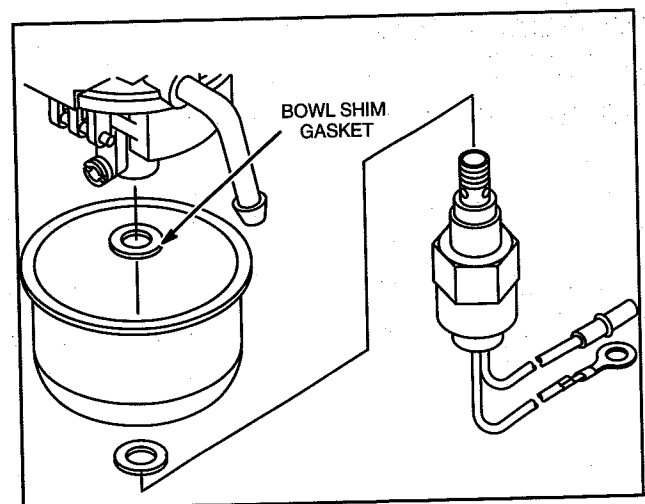

Fig. 28 – Removing Float Bowl

CARBURETOR AND RELATED COMPONENTS

Note: Float hinge pin is swaged on one side. When removing, drive hinge pin from side opposite swage.

2. Drive out float hinge pin with a small punch. Remove float and fuel inlet valve, Fig. 29.
3. Remove idle passage plug, Fig. 29.

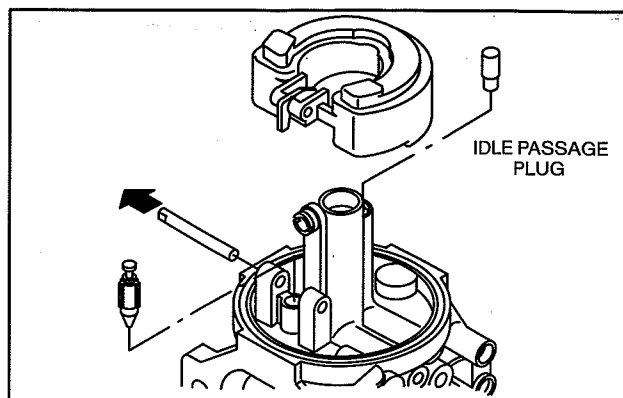

Fig. 29 – Removing Float And Idle Passage Plug

4. Remove rubber float bowl gasket, Fig. 30.

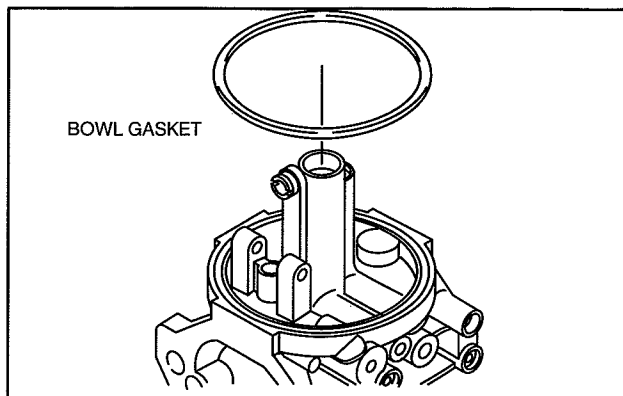

Fig. 30 – Removing Gasket

5. Remove fixed main jet and gasket, Fig. 31. Discard gasket.

Note: Consult the illustrated parts list for correct part number for special high altitude jet, if required. Also, See page 23 for main jet identification chart.

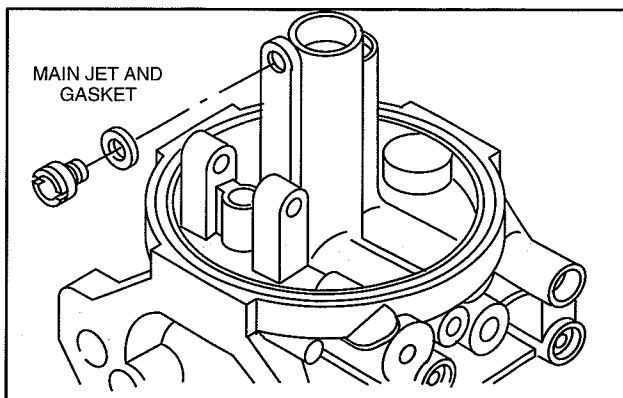

Fig. 31 – Removing Main jet

6. Remove three screws, thermostat retainer and ground wire, Fig. 32. Discard thermostat gasket.

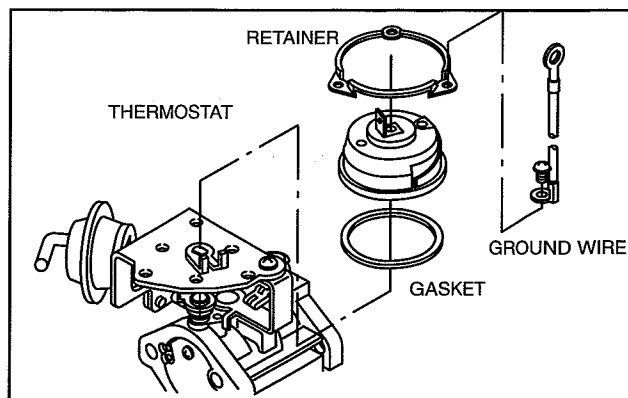

Fig. 32 – Removing Thermostat

CARBURETOR AND RELATED COMPONENTS

7. Remove screw and choke pre-load lever, Fig. 33.
8. Remove two screws, choke plate and choke shaft, Fig. 33.

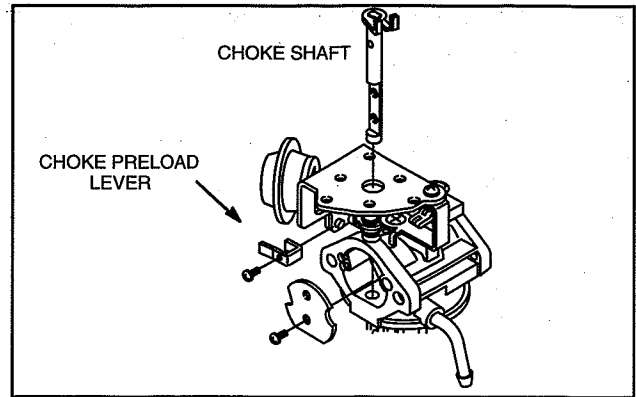

Fig. 33 – Removing Choke Shaft

9. Remove two screws and vacuum choke break, Fig. 34.

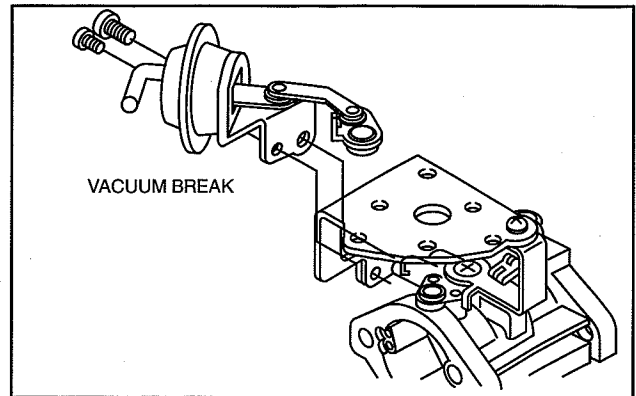

Fig. 34 – Removing Choke Vacuum Break

10. Remove idle jet plug and idle jet, Fig. 35.

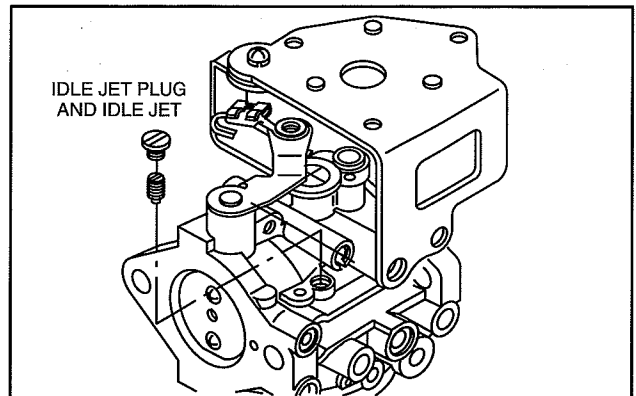

Fig. 35 – Removing Idle Jet

11. Remove idle mixture screw and "O"-ring, Fig. 36. Discard "O"-ring.

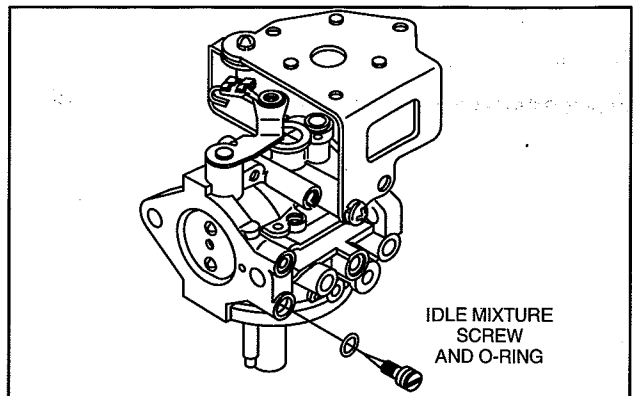

Fig. 36 – Removing Idle Mixture Screw

CARBURETOR AND RELATED COMPONENTS

Note: If engine is equipped with electronic governor system, DO NOT remove throttle plate or throttle shaft. This is a precision assembly and should not be disassembled.

If engine is not equipped with electronic governor proceed to step 12.

12. Mark throttle plate before removing so that it may be re-installed in the same position. Sides of throttle plate are beveled.
13. Remove two screws, throttle plate, throttle shaft and seal, Fig. 37.
 - a. Discard seal.

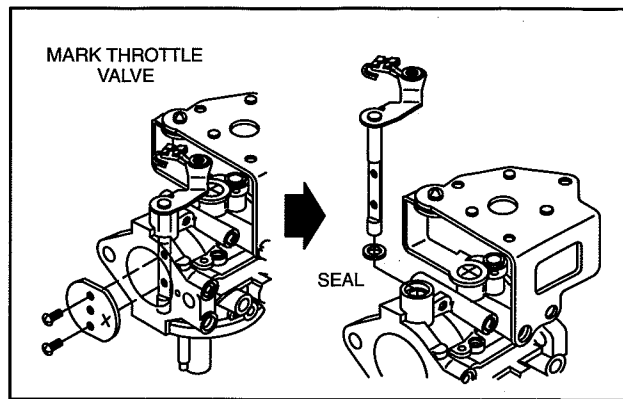

Fig. 37 – Removing Throttle Shaft

CLEAN CARBURETOR

Remove gasket material from mounting surfaces. Gummy or dirty carburetors should be cleaned in a carburetor cleaner. DO NOT soak rubber, neoprene or plastic parts in cleaner.

IMPORTANT: If engine is equipped with electronic governor system, DO NOT clean carburetor in carburetor cleaner. The carburetor is equipped with sealed ball bearings for the throttle shaft, which will be damaged if carburetor is immersed in carburetor cleaner. Ball bearings are not replaceable.

INSPECT CARBURETOR

Inspect all parts for wear, cracks, nicks and burrs. Inspect float for leaks. Replace all damaged parts.

CHECK THROTTLE, CHOKE SHAFT AND BODY FOR WEAR

1. Lay carburetor on flat surface and check throttle and choke shaft clearance as shown in Fig. 38.

Throttle shaft and choke shaft clearance must not exceed .25 mm (.010").

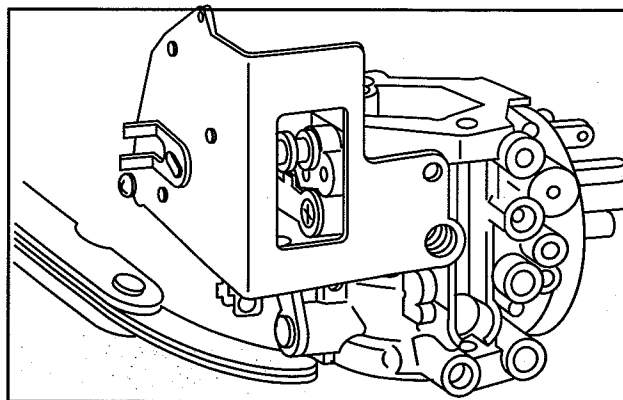

Fig. 38 – Checking Clearance

2. Inspect throttle shaft and choke shaft for wear, Fig. 39.

Replace if worn.

If carburetor body is worn, replace carburetor.

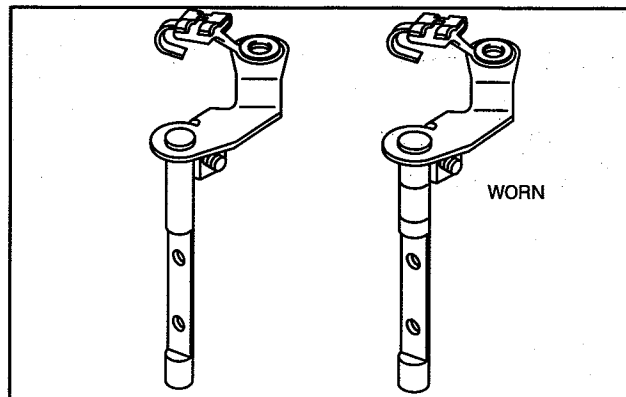

Fig. 39 – Checking Throttle Shaft

ASSEMBLE CARBURETOR

When assembling carburetor, use new seals and gaskets.

1. Install throttle shaft and new seal, Fig. 40.
 - a. Install throttle plate and screws.

Note: Use LOCTITE® 222 on screw threads.

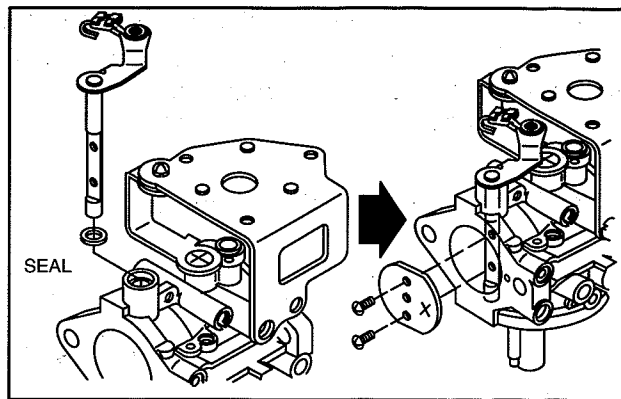

Fig. 40 – Installing Throttle Shaft

2. Install idle mixture screw with new “O”-ring, Fig. 41.

DO NOT tighten idle mixture screw.

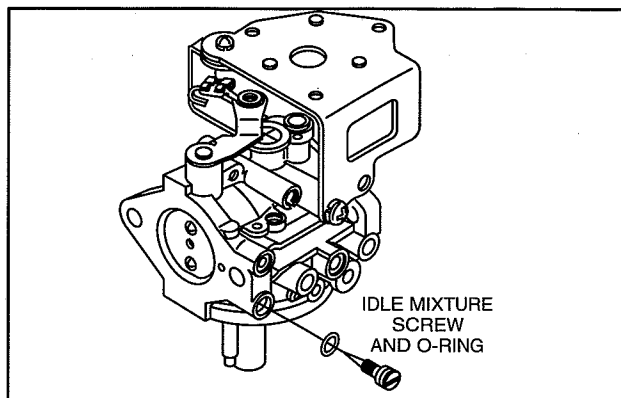

Fig. 41 – Installing Idle Mixture Screw

3. Install idle jet and plug, Fig. 42.

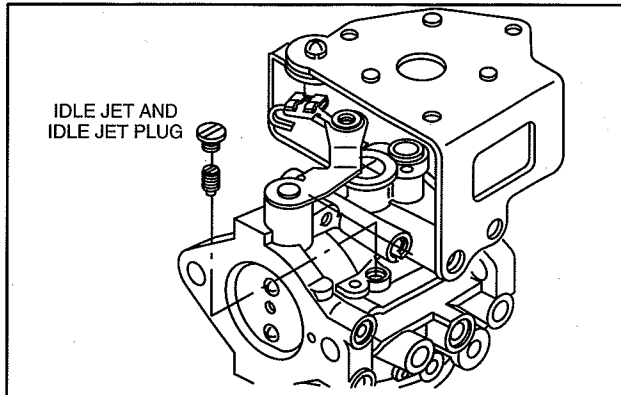

Fig. 42 – Installing Idle Jet

4. Assemble vacuum choke break to bracket, Fig. 43.

Note correct position of pivot arm, Fig. 43.

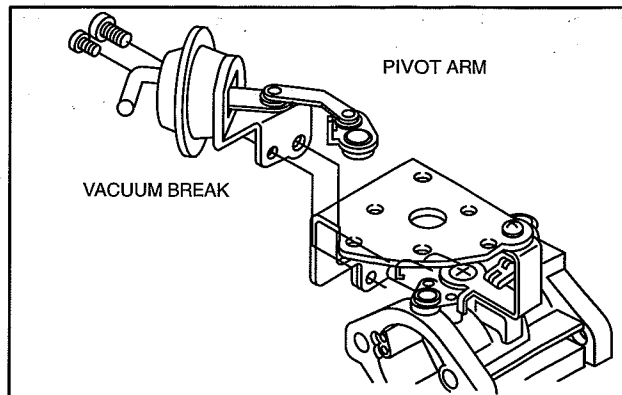

Fig. 43 – Assemble Vacuum Choke Breaker

CARBURETOR AND RELATED COMPONENTS

5. Install choke shaft through pivot arm bushing and into carburetor body, Fig. 44.

Note: Specification between arms: 2.5 mm (3/32").

6. Install choke plate.

Note: Use LOCTITE® 222 on screw threads.

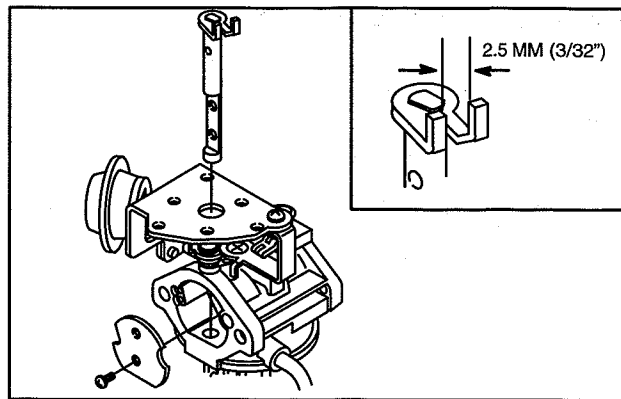

Fig. 44 – Installing Choke Shaft

7. Install thermostat with new gasket, Fig. 45.

- a. Insert hook on thermostat spring between arms on choke shaft.
- b. Assemble thermostat retainer leaving screws loose.

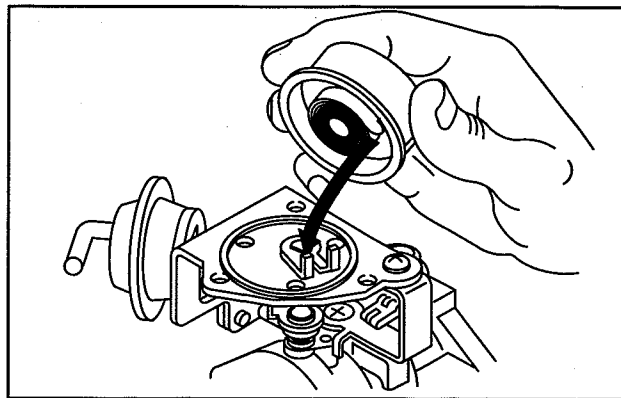

Fig. 45 – Installing Thermostat

8. Hold choke plate closed and rotate thermostat until match marks are aligned, Fig. 46.

- a. Tighten screws.

Note: Make sure choke plate remains closed while pre-loading thermostat spring.

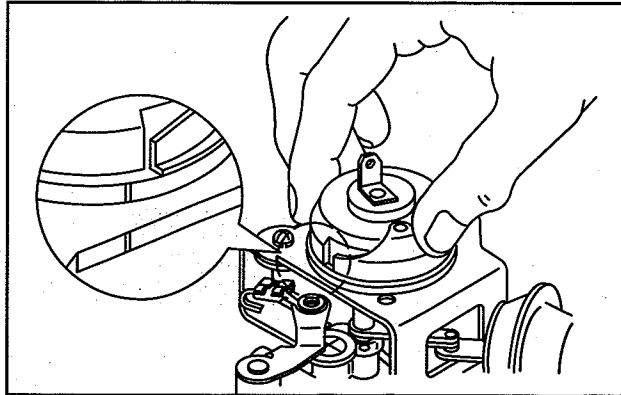

Fig. 46 – Pre-loading Thermostat Spring

9. Assemble choke pre-load lever to choke shaft, Fig. 47.

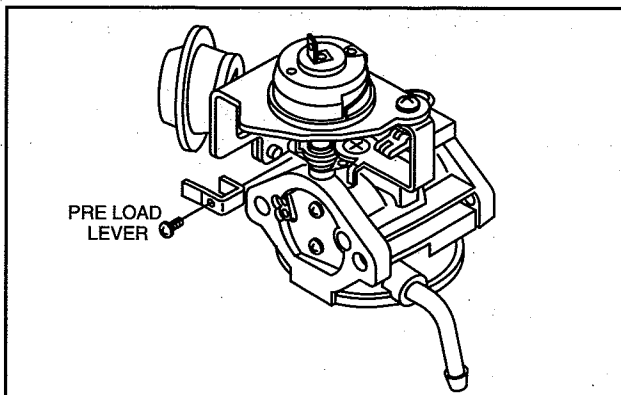

Fig. 47 – Assembling Pre-load Lever

CARBURETOR AND RELATED COMPONENTS

10. Install float, Fig. 48.

- a. Assemble inlet valve to float.
- b. Install float hinge pin.
- c. Install idle passage plug.
- d. Install fixed main jet with new gasket.
- e. Install new bowl gasket.

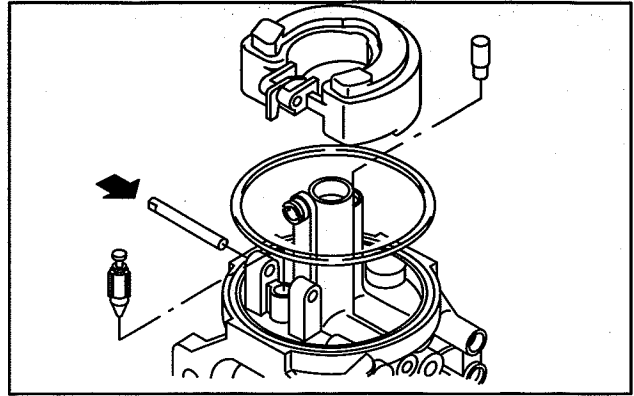

Fig. 48 – Installing Float

11. Install float bowl with new gaskets, Fig. 49.

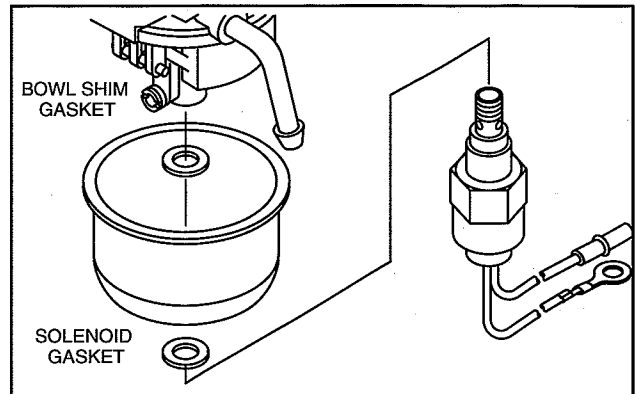

Fig. 49 – Install Float Bowl

CHECKING VACUUM CHOKE BREAK

A Mityvac® vacuum pump or equivalent is required when checking and adjusting the vacuum choke break.

1. Connect vacuum pump to choke break and activate pump to specification shown.

Specification: **10.0 – 14.0 cm. Hg. vac.**
 (4.0 – 5.5 in. Hg. vac.)

Choke plate should partially open and pump gauge should maintain vacuum.

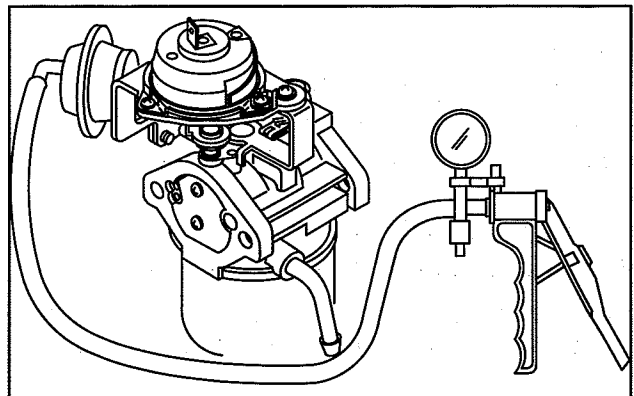

Fig. 50 – Checking Choke

2. Check dimension from edge of choke plate to edge of carburetor throat, Fig. 51.

Specification: **14.0 – 15.0 mm**
 (.550 – .590”).

If dimension is not to specification the choke pre-load lever must be adjusted.

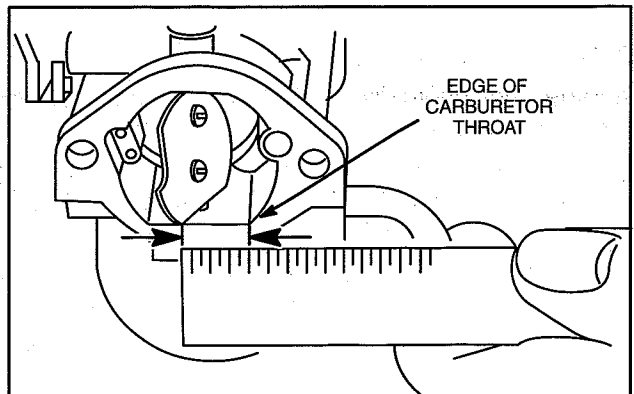

Fig. 51 – Checking Choke

CARBURETOR AND RELATED COMPONENTS

ADJUSTING CHOKE PRE-LOAD LEVER

1. Release vacuum pump so that choke closes.
2. Manually open choke to end of travel and hold in this position.
3. Carefully bend pre-load lever, Fig. 52:
 - a. Bend lever to left to increase dimension.
 - b. Bend lever to right to decrease dimension.

Re-check and adjust as necessary.

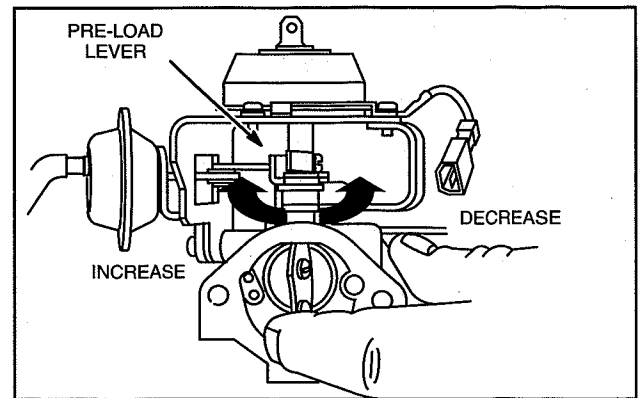

Fig. 52 – Adjusting Choke

CHECKING P.T.C. HEATER

The digital multimeter, Tool #19464 is required to test the P.T.C. heater.

The following test will be made with the meter in the Ω position.

1. Check resistance between tab terminal on thermostat and ground wire as shown, Fig. 53.

Specification: 2.0 – 40.0 Ω @ (70° F)

Replace thermostat if not to specification.

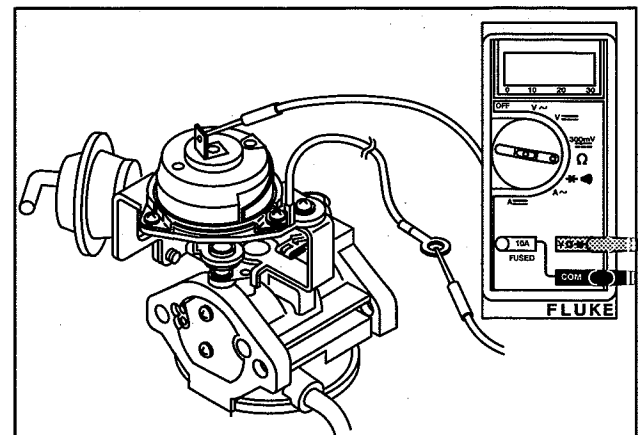

Fig. 53 – Checking Thermostat

INSTALL CARBURETOR

1. Assemble insulator with gaskets, carburetor and air horn with gasket to intake manifold, Fig. 54.

Note: Attach thermostat ground wire to air horn as shown.

Torque nuts to 8.0 Nm (70 in. lbs.).

2. Install governor link and governor link spring.

Reinstall air cleaner tube, vacuum line, harness connectors and fuel line.

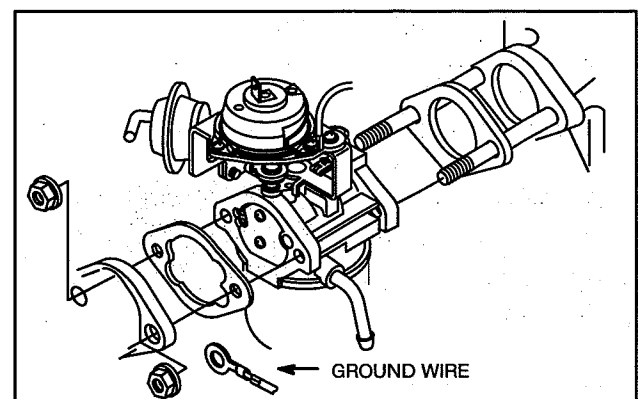

Fig. 54 – Installing Carburetor

INSTALL VACUUM LIMITER

To install vacuum limiter on engines not originally equipped with vacuum limiter, proceed as follows.

1. Cut vacuum line approximately 50 mm (2") from vacuum break side and install vacuum limiter with blue end facing intake manifold, Fig. 55.

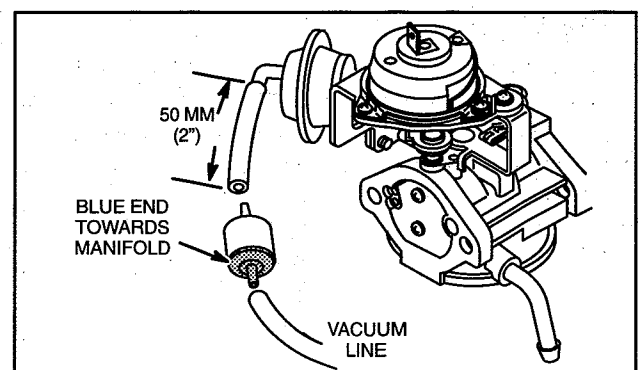

Fig. 55 – Installing Vacuum Limiter

CARBURETOR AND RELATED COMPONENTS

INITIAL CARBURETOR ADJUSTMENT

Turn idle mixture screw clockwise until it just seats. **DO NOT FORCE**. Turn screw counter-clockwise 1-1/4 turn, Fig. 56. This setting will permit engine to start.

Final adjustment will be made with engine running.

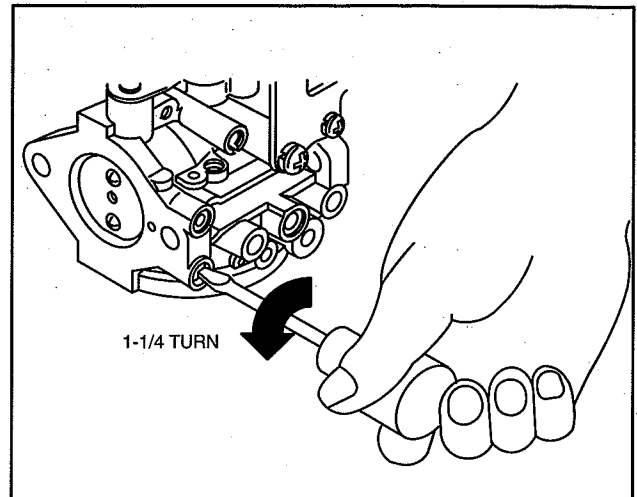

Fig. 56 – Initial Carburetor Adjustment

FINAL CARBURETOR ADJUSTMENT

ALL CARBURETOR ADJUSTMENTS MUST BE MADE WITH THE AIR CLEANER INSTALLED.

Start and run engine at low speed for approximately five minutes. Or, if equipped with temperature gauge, until needle moves from C or COLD position.

1. With control lever on equipment in SLOW position, hold throttle lever against idle speed screw and adjust idle speed to 1200 RPM, Fig. 57.
2. SLOWLY turn idle mixture screw clockwise until engine speed just starts to slow (lean mixture).
3. Then SLOWLY turn idle mixture screw counter-clockwise until engine speed just starts to slow (rich mixture).
4. Turn idle mixture screw to mid point between rich and lean, Fig. 58.
5. Hold throttle lever against idle speed screw and re-adjust idle speed to 1500 RPM.

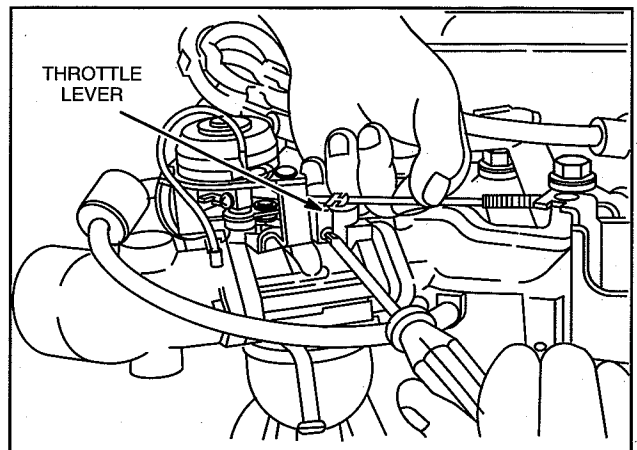

Fig. 57 – Adjusting Idle Speed

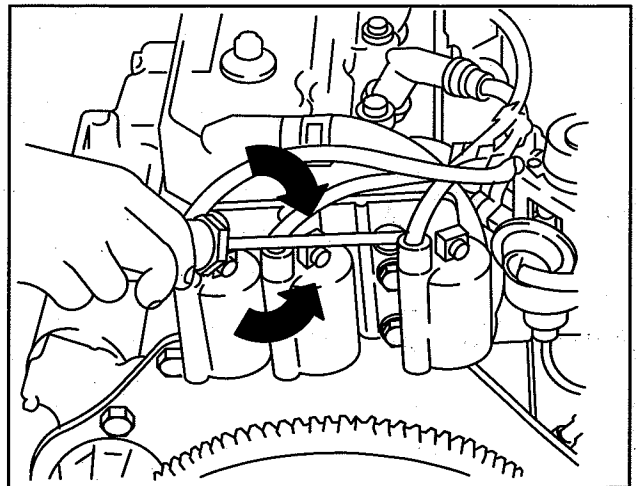
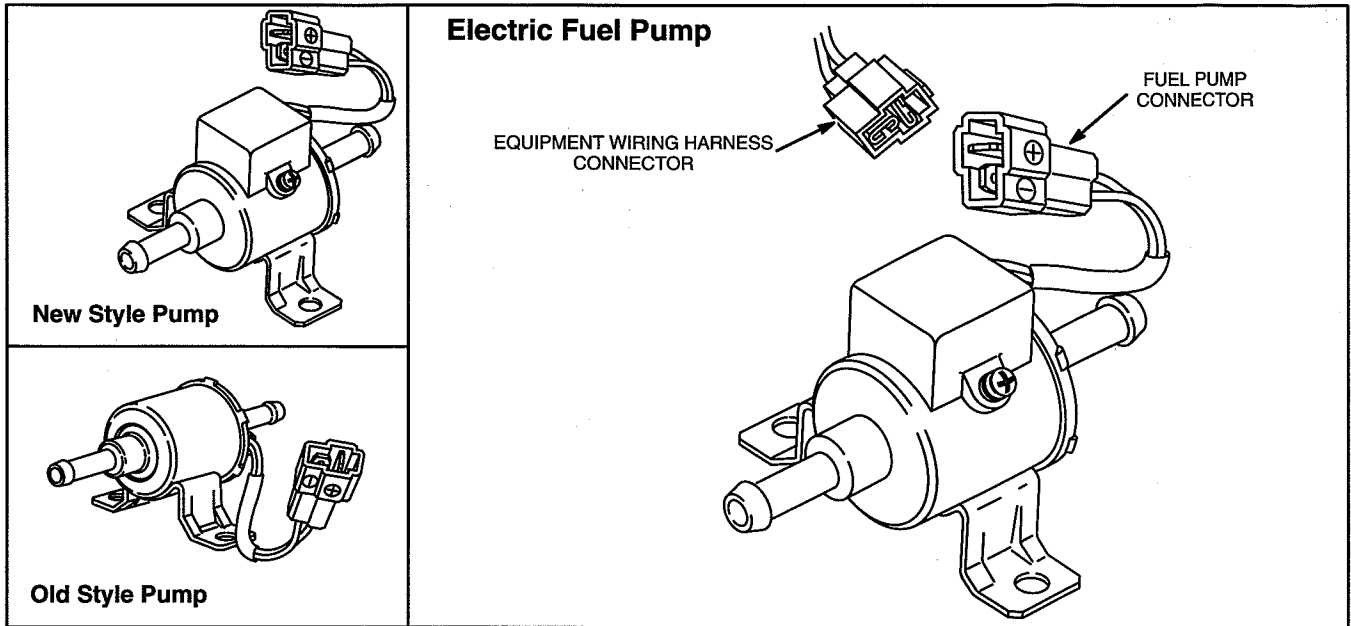

Fig. 58 – Adjusting Idle Mixture

CARBURETOR AND RELATED COMPONENTS



Fuel Pump Specifications	New Style Pump USED AFTER 97033100	Old Style Pump USED BEFORE 97040100
Type	12 Volt Electro magnetic	12 Volt Electro magnetic
Delivery Output-Minimum	800 cc/minute (27 fl. oz.)	350 cc/minute (12 fl. oz.)
Fuel Pump Pressure-Maximum	0.25 Bar (3.5 psi)	0.25 Bar (3.5 psi)

IMPORTANT: For proper fuel pump operation and fuel flow, fuel pump should be installed lower than fuel tank in a vertical position as possible (outlet side up). See figure below. Mount fuel pump away from sources of heat.

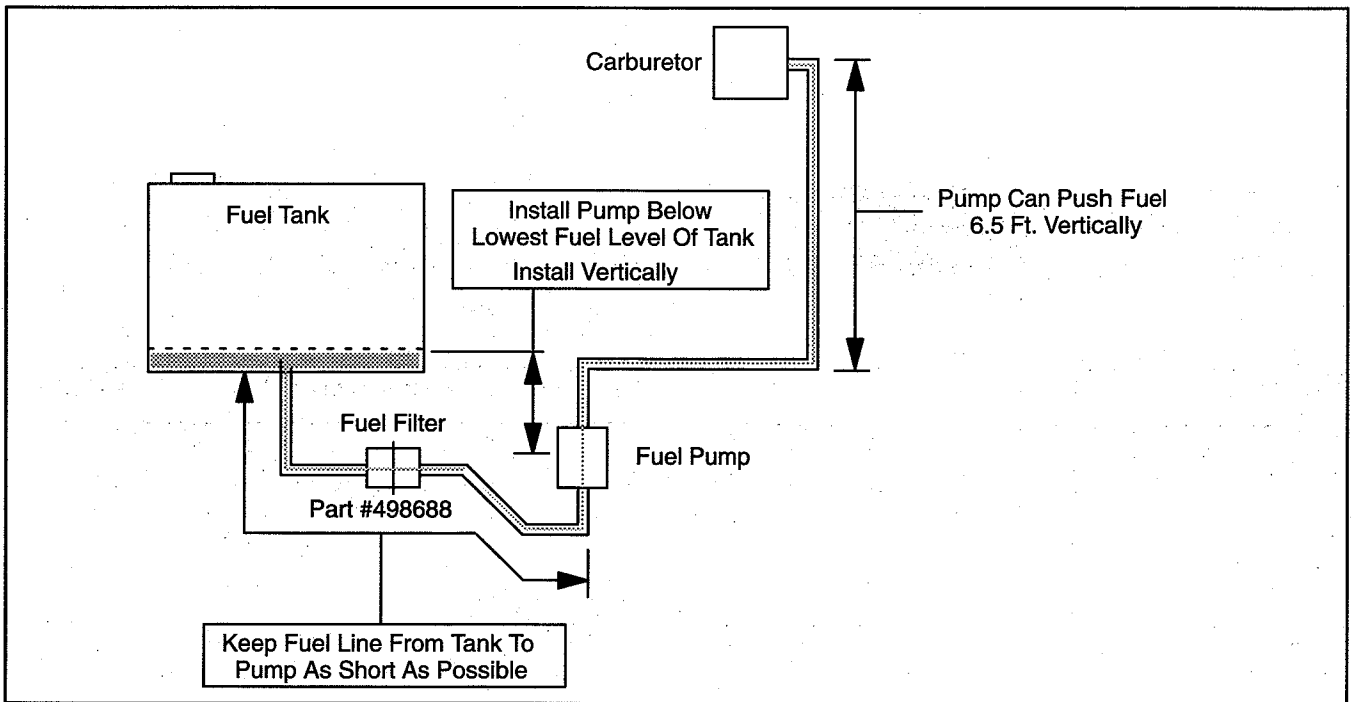

10

CHECKING FUEL PUMP OUTPUT

A graduated container is required when testing the fuel pump.

1. Disconnect fuel line at carburetor.
2. Turn ignition switch to ON position and note fuel flow into graduated container.
 - a. If fuel flow is less than specification shown in table above, replace fuel pump.

Note: A plugged fuel filter and/or low battery voltage may cause insufficient fuel flow.

If there is no fuel flow when keyswitch is in ON position, check fuel pump wiring.

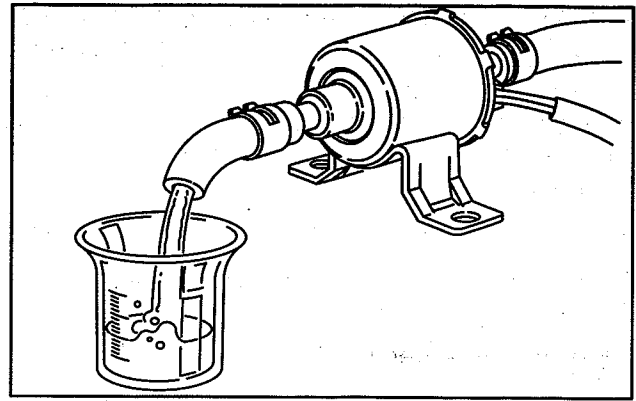

Fig. 59 – Checking Fuel Pump Output

TEST EQUIPMENT

The digital multimeter, Tool #19464 is required to test fuel pump.

The fuel pump test will be performed with the meter in the $V \text{ ---}$ (DC volts) position, Fig. 60.

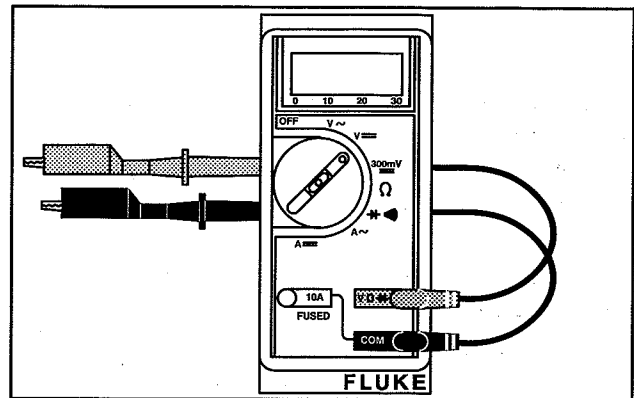

Fig. 60 – Digital Multimeter

TESTING FUEL PUMP WIRING

1. With keyswitch in OFF position, disconnect fuel pump equipment wiring harness connector.
2. Insert meter test leads into wiring harness connector as shown in Fig. 61. Then turn keyswitch to ON position.
 - a. Meter should display battery voltage at connector.

If meter does not display battery voltage, problem is with wiring harness and/or fuel pump relay (as supplied by equipment manufacturer), and/or ignition module. Also, check for loose or broken wires.

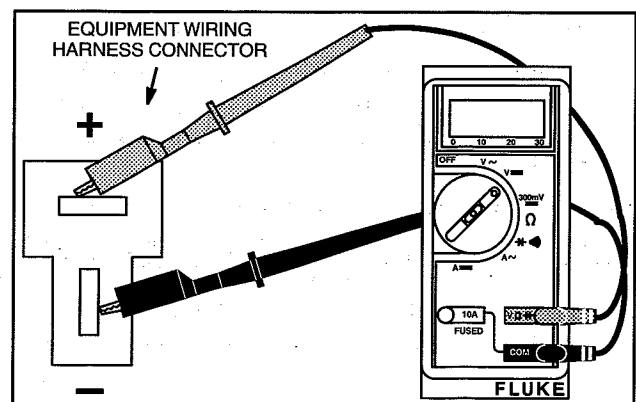

Fig. 61 – Checking Wiring

CARBURETOR AND RELATED COMPONENTS

ANTI-AFTERFIRE SOLENOID

Some carburetors are equipped with an Anti-Afterfire solenoid controlled by the equipment ignition switch. When the equipment switch is in the "Off" position, the solenoid valve plunger closes, stopping fuel flow through the fixed main jet or high speed nozzle. When the switch is in the "On" and "Start" position, the solenoid valve opens, allowing normal fuel flow. Solenoid is operating properly if a click is heard when equipment ignition switch is turned "On" and "Off." If solenoid is not working (defective solenoid or equipment wiring), the engine will not start or run.

Note: Anti-afterfire solenoid requires a minimum of 9 volts DC to function.

Important: Engines equipped with anti-afterfire solenoid are equipped with an air horn gasket with a ground clip imbedded in the gasket, Fig. 62. Anti-afterfire solenoid will not function if ground clip is removed or damaged.

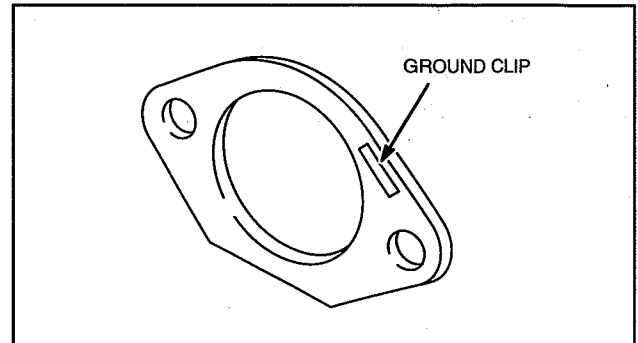

Fig. 62 – Air Horn Gasket With Ground Clip

TESTING ANTI-AFTERFIRE SOLENOID

If solenoid does not click, the problem may be in equipment wiring. To determine whether problem is with wiring, perform this test.

TEST EQUIPMENT

The digital multimeter, Tool #19464 is required to test the solenoid equipment wiring.

The wiring test will be performed with the meter in the $V \text{ ---}$ (DC volts) position, Fig. 63.

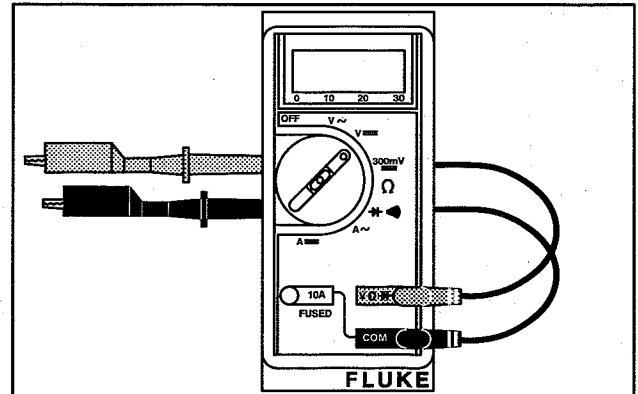

Fig. 63 – Digital Multimeter

TESTING EQUIPMENT SOLENOID WIRING

1. With keyswitch in OFF position, disconnect equipment wiring harness connector from solenoid.
2. Insert red meter test lead into wiring harness connector and attach black test lead to a good ground, Fig. 64.
3. Turn keyswitch to ON position.
 - a. Meter should display battery voltage at connector. Test solenoid.

If meter does not display battery voltage, problem is with wiring harness. Check for loose or broken wire.

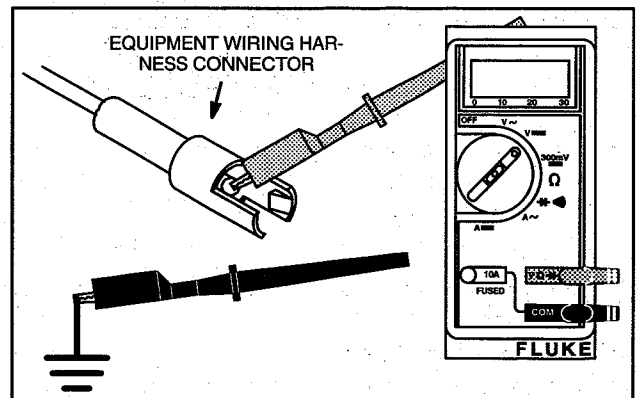

Fig. 64 – Checking Wiring

CARBURETOR AND RELATED COMPONENTS

TESTING SOLENOID

1. Remove solenoid from carburetor.
2. Place either terminal of a 9 volt transistor battery on the solenoid connector and other terminal on body of solenoid or ground wire.
 - a. Plunger should retract freely.
 - b. When battery is removed, plunger should return freely.

Replace solenoid if plunger sticks or doesn't move.

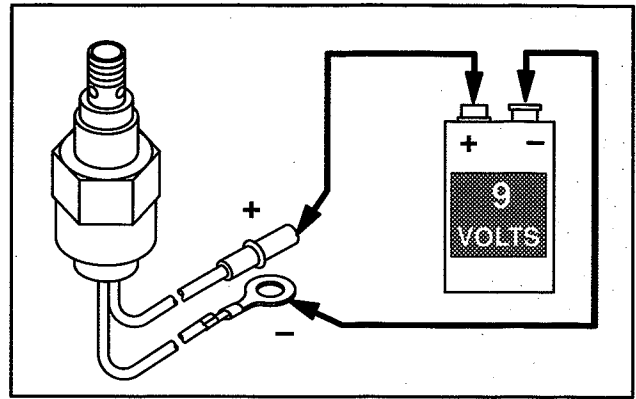

Fig. 65 – Checking Solenoid

FUEL FILTER

Replace inline fuel filter every 600 hours.

Inline fuel filter has an arrow to indicate fuel flow direction. Always install with arrow towards carburetor.

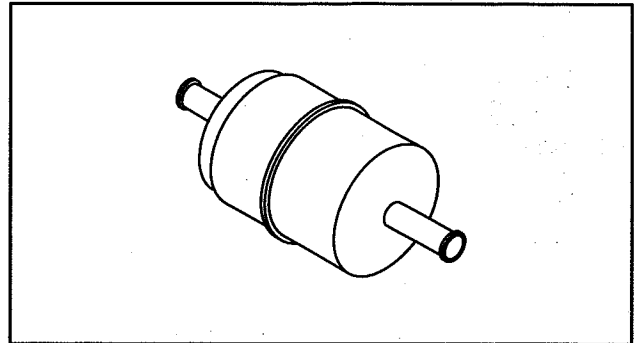

Fig. 66 – Fuel Filter

CARBURETOR MAIN JETS

The carburetor main jet orifice size is stamped in the body of the jet, Fig. 67. See chart below for identification numbers and suggested application.

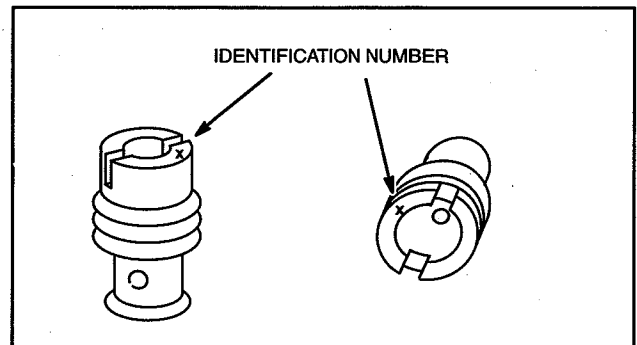

Fig. 67 – Main Jet Identification

Carburetor	*Std. Jet 0 – 4000 Ft. (0 – 1220 m)	*High Altitude 3500 – 7000 Ft. (1067 – 2134 m)	**High Altitude 7000 – 10,000 Ft. (2134 – 3048 m)
Standard Choke (700 G)	# 106	# 102	#98
Automatic Choke (700 G)	# 128	# 120	#112
Standard Choke (950 G)	# 114	# 110	#106

* See Illustrated Parts List For Correct Part Number

** Special Applications Only – Contact Source Of Supply

[The page contains extremely faint, illegible text, likely bleed-through from the reverse side of the document. The text is too light to transcribe accurately.]

Section 11

Electrical Systems

Ignition System – Charging Systems – Starter System

Section Contents

	Page
IGNITION SYSTEM COMPONENTS	2
TEST EQUIPMENT	3
TESTING TRIGGER	3
TESTING IGNITION MODULE	4
TESTING IGNITION COILS	6
14 AMP CHARGING SYSTEM	6
14 AMP WIRING DIAGRAM	7
TEST EQUIPMENT	8
TESTING ALTERNATOR – AC OUTPUT	8
TESTING REGULATOR-RECTIFIER – DC OUTPUT	8
CHARGING INDICATOR CIRCUIT	9
TESTING CHARGING INDICATOR BULB AND WIRING	9
40 AMP WIRING DIAGRAM	10
40 AMP CHARGING SYSTEM	11
TEST EQUIPMENT	11
TESTING ALTERNATOR – DC OUTPUT	11
DISASSEMBLE ALTERNATOR	12
CHECKING BEARINGS	13
INSTALL BALL BEARING	14
CHECKING ROTOR	14
CHECK BRUSHES	14
CHECK REGULATOR	15
CHECK RECTIFIER	15
ASSEMBLE ALTERNATOR	15
STARTER SYSTEM	18
STARTER CURRENT DRAW TEST	18
TEST EQUIPMENT	18
TESTING STARTER	19
NO LOAD STARTER CURRENT DRAW TEST	19
EQUIPMENT TO TEST SOLENOID	20
TESTING SOLENOID	20
REMOVING PINION GEAR ASSEMBLY	21
INSTALL PINION GEAR ASSEMBLY	22
DISASSEMBLE STARTER MOTOR	23
INSPECT ARMATURE COMMUTATOR	24
INSPECT BRUSHES	24
REPLACE BRUSHES	25
ASSEMBLE STARTER	26

ELECTRICAL SYSTEM

IGNITION SYSTEM COMPONENTS

The ignition system consists of three major components, Fig. 1:

1. A permanent magnet trigger and signal rotor integral with the crankshaft pulley.
2. A transistorized ignition module which advances and retards the ignition timing electronically.
3. A battery powered ignition coil for each cylinder.

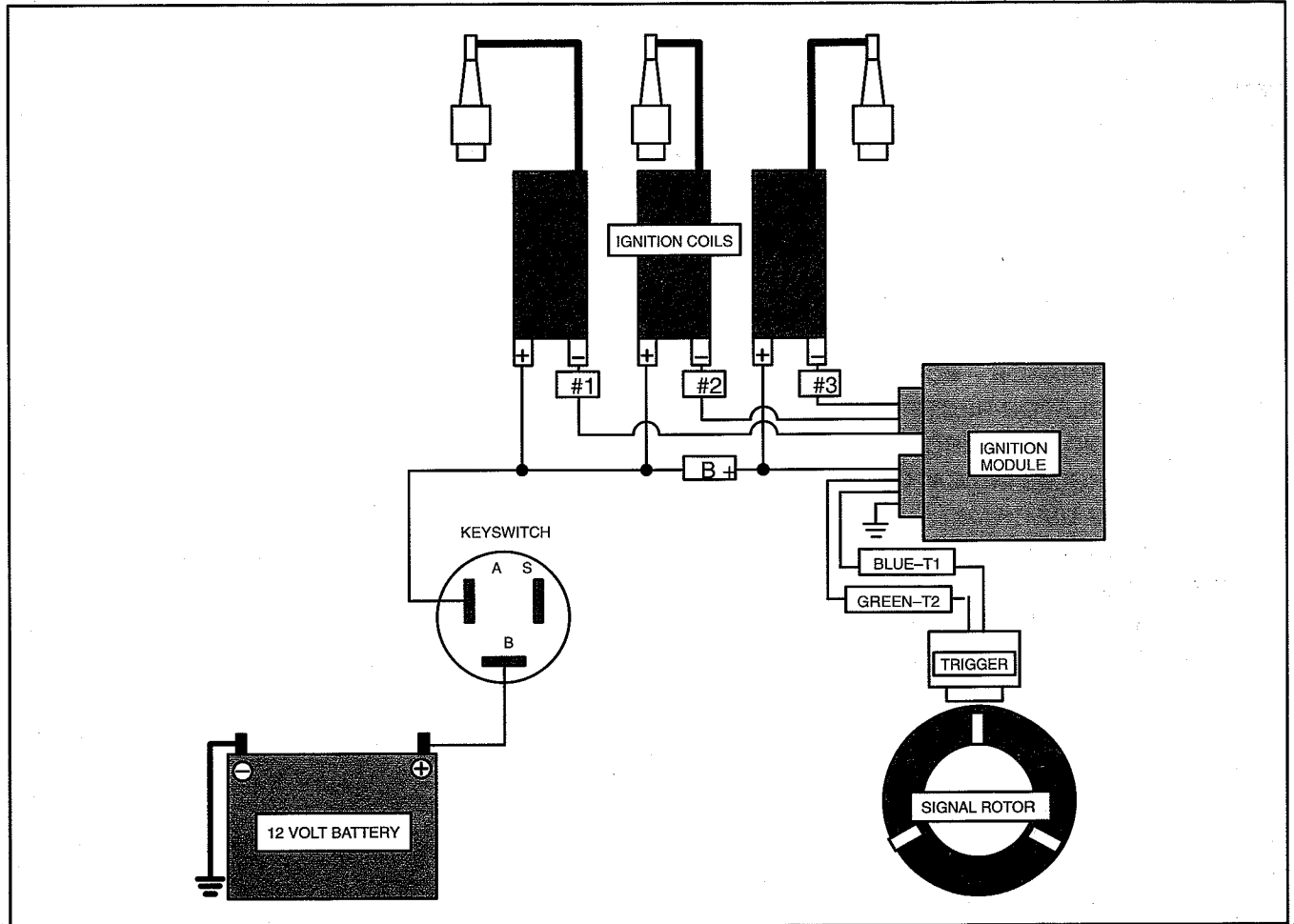

Fig. 1 - Ignition System Components

TEST EQUIPMENT

The digital multimeter, Tool #19390 is required to test the ignition components, Fig. 2.

NOTE: All ignition tests are performed with engine NOT running.

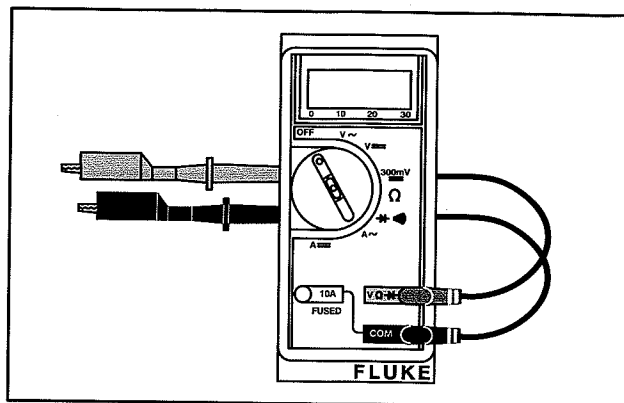



Fig. 2 – Digital Multimeter

TESTING TRIGGER

The following test will be made with the meter in the “Diode Test Position” .

1. Attach a meter test lead to each trigger terminal in connector, Fig. 3.
 - a. Meter should “Beep” once.
 - b. If meter makes a continuous tone or displays OL, trigger is defective. Replace trigger.
2. Reverse test leads.
 - a. Meter should “Beep” once.
 - b. If meter makes a continuous tone or displays OL, trigger is defective. Replace trigger.

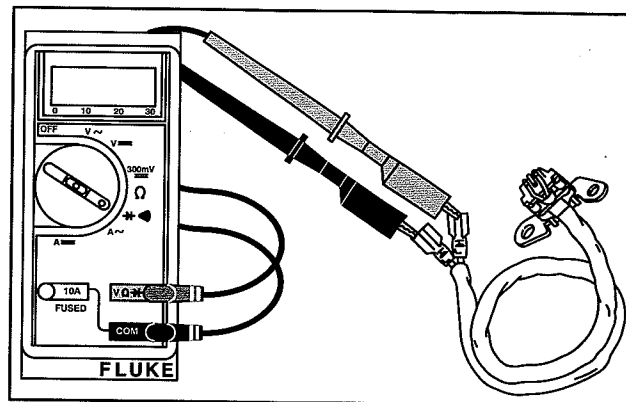

Fig. 3 – Testing Trigger

IGNITION MODULE

Two different ignition modules are used. The test specifications are different depending upon the identification number on the ignition module, Fig. 4.

1. Locate identification number on ignition module.
2. Refer to correct page for specifications.

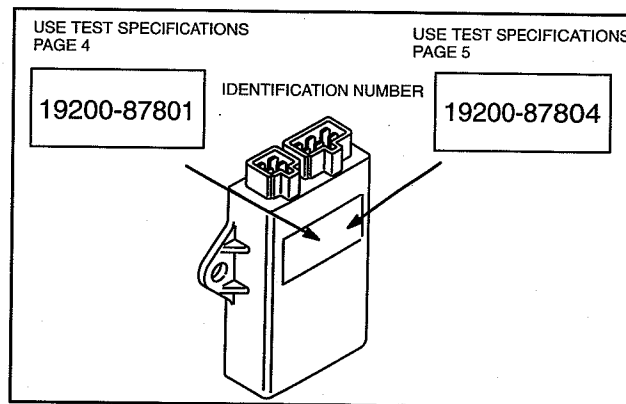
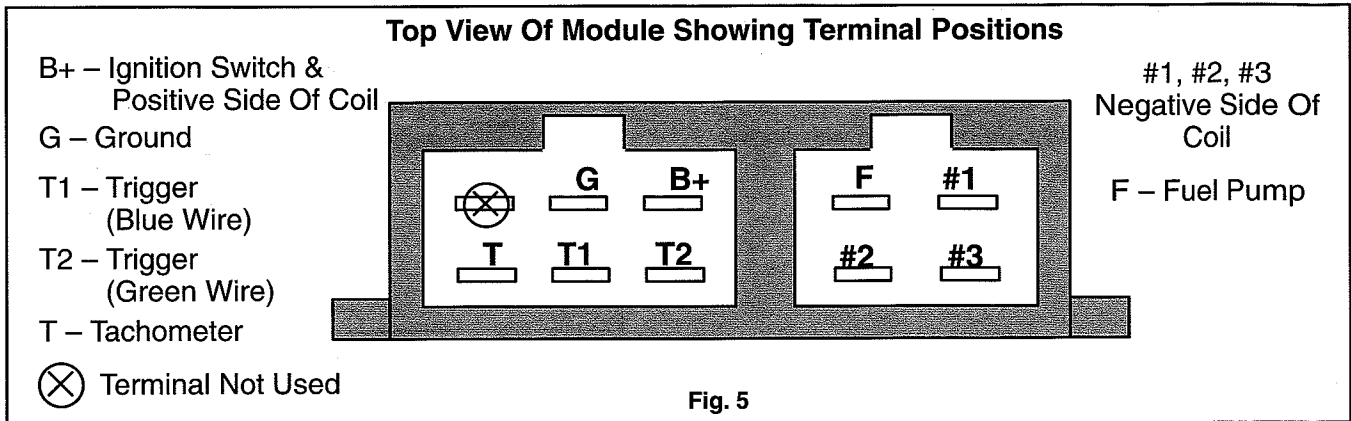

Fig. 4 – Ignition Module Identification Numbers

TESTING IGNITION MODULE – IDENTIFICATION NO. 19200-87801

The following test will be made with the meter in the Ω position.

The ignition module test is performed by measuring the resistance (Ω) between the terminals shown in Figure 5. Specifications are shown in chart below.



Attach red meter test lead to the terminal shown at the top of the column. Attach the black test lead to the terminal shown in the vertical column below and note reading. Then move the black test lead to the next terminal below. Proceed until all the terminals in the vertical column have been tested. Now move the red test lead to the terminal shown at the top of the next vertical column. Proceed until all terminals have been tested.

Red Meter Test Lead

		B+	G	T1	T2	#1	#2	#3	T	F
Black Meter Test Lead	B+	⊗	1.5 M to OL	1.5 M to OL	1.5 M to OL	1.5 M to OL	1.5 M to OL	1.5 M to OL	1.5 M to OL	1.5 M to OL
	G	0.5 to 2.5M	⊗	10 to 40K	0 to 100 Ω	1.5 M to OL	1.5 M to OL	1.5 M to OL	1.5 M to OL	1.5 M to OL
	T1	0.5 to 2.5M	10 to 40K	⊗	10 to 40K	1.5 M to OL	1.5 M to OL	1.5 M to OL	1.5 M to OL	1.5 M to OL
	T2	0.5 to 2.5M	0 to 100 Ω	10 to 40K	⊗	1.5 M to OL	1.5 M to OL	1.5 M to OL	1.5 M to OL	1.5 M to OL
	#1	1.5 M to OL	0.5 to 2.5M	0.5 to 2.5M	0.5 to 2.5M	⊗	1.5 M to OL	1.5 M to OL	1.5 M to OL	1.5 M to OL
	#2	1.5 M to OL	0.5 to 2.5M	0.5 to 2.5M	0.5 to 2.5M	1.5 M to OL	⊗	1.5 M to OL	1.5 M to OL	1.5 M to OL
	#3	1.5 M to OL	0.5 to 2.5M	0.5 to 2.5M	0.5 to 2.5M	1.5 M to OL	1.5 M to OL	⊗	1.5 M to OL	1.5 M to OL
	T	1.5 M to OL	1.5 M to OL	1.5 M to OL	1.5 M to OL	1.5 M to OL	1.5 M to OL	1.5 M to OL	⊗	1.5 M to OL
	F	1.5 M to OL	1.5 M to OL	1.5 M to OL	1.5 M to OL	1.5 M to OL	1.5 M to OL	1.5 M to OL	1.5 M to OL	⊗

Values Shown Are Resistance In Ohms (Ω)

OL = Incomplete Circuit (Infinity)

⊗ = No Test

TESTING IGNITION MODULE – IDENTIFICATION NO. 19200-87804

The following test will be made with the meter in the Ω position.

The ignition module test is performed by measuring the resistance (Ω) between the terminals shown in Figure 6. Specifications are shown in chart below.

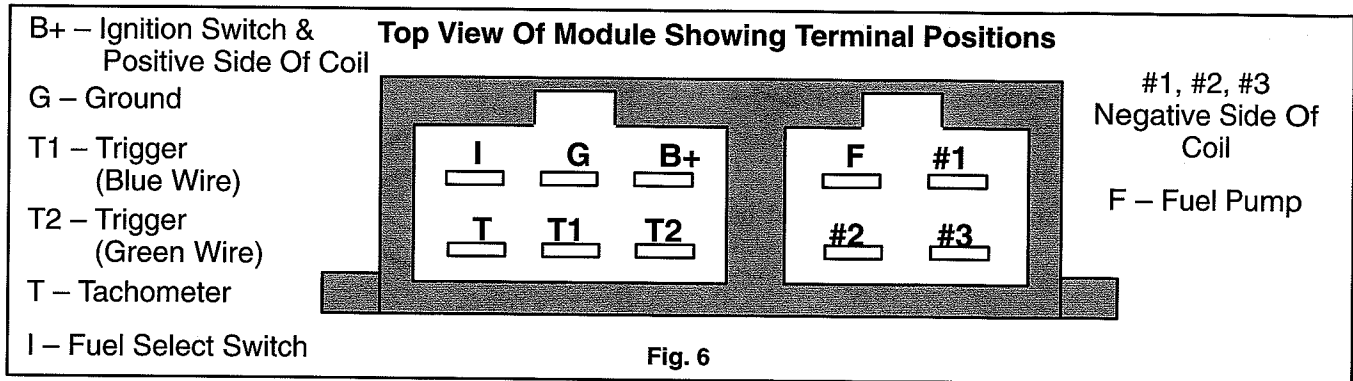

Attach red meter test lead to the terminal shown at the top of the column. Attach the black test lead to the terminal shown in the vertical column below and note reading. Then move the black test lead to the next terminal below. Proceed until all the terminals in the vertical column have been tested. Now move the red test lead to the terminal shown at the top of the next vertical column. Proceed until all terminals have been tested.

Red Meter Test Lead

		B+	G	T1	T2	#1	#2	#3	T	F	I
Black Meter Test Lead	B+	×	1.5 M to OL	1.5 M to OL	1.5 M to OL	1.5 M to OL	1.5 M to OL	1.5 M to OL	1.5 M to OL	1.5 M to OL	1.5 M to OL
G	1 to 25M	×	5 to 20K	Less than 1 Ω	1.5 M to OL	1.5 M to OL	1.5 M to OL	1 to 5K	1.5 M to OL	0.5 to 2.5K	
T1	1 to 25M	5 to 20K	×	5 to 20K	1.5 M to OL	1.5 M to OL	1.5 M to OL	5 to 25K	1.5 M to OL	5 to 25K	
T2	1 to 25M	Less than 1 Ω	5 to 20K	×	1.5 M to OL	1.5 M to OL	1.5 M to OL	1 to 5K	1.5 M to OL	0.5 to 2.5K	
#1	1.5 M to OL	1 to 25M	1 to 25M	1 to 25M	×	1.5 M to OL	1.5 M to OL	1 to 25M	1.5 M to OL	1 to 25M	
#2	1.5 M to OL	1 to 25M	1 to 25M	1 to 25M	1.5 M to OL	×	1.5 M to OL	1 to 25M	1.5 M to OL	1 to 25M	
#3	1.5 M to OL	1 to 25M	1 to 25M	1 to 25M	1.5 M to OL	1.5 M to OL	×	1 to 25M	1.5 M to OL	1 to 25M	
T	1 to 25M	1 to 5K	5 to 25K	1 to 5K	1.5 M to OL	1.5 M to OL	1.5 M to OL	×	1.5 M to OL	1 to 5K	
F	1.5 M to OL	1 to 25M	1 to 25M	1 to 25M	1.5 M to OL	1.5 M to OL	1.5 M to OL	1.5 M to OL	×	1 to 25M	
I	1 to 25M	0.5 to 2.5K	5 to 25K	0.5 to 2.5K	1.5 M to OL	1.5 M to OL	1.5 M to OL	1 to 5K	1.5 M to OL	×	

Values Shown Are Resistance In Ohms (Ω)

OL = Incomplete Circuit (Infinity)

×

ELECTRICAL SYSTEM

TESTING IGNITION COILS

The following test will be performed with the meter in Ω position.

1. Check coil primary resistance between + and - terminals as shown in Fig. 7.

Specification: $3.4\Omega - 4.6\Omega$

If ignition coil is not within specification, it must be replaced.

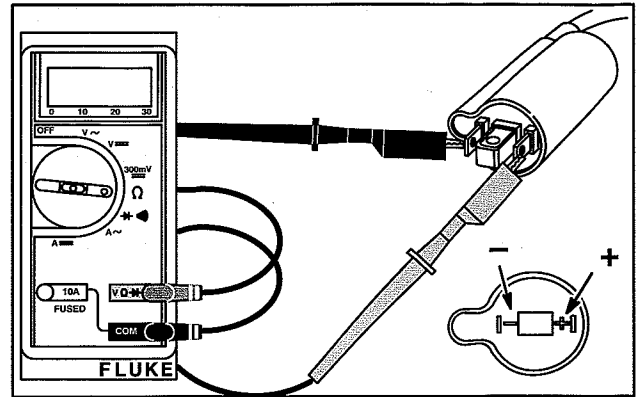

Fig. 7 – Testing Ignition Coil Primary

2. Check coil secondary resistance between + terminals and spark plug lead as shown in Fig. 8.

Specification: $10.4\text{ k}\Omega - 24.6\text{ k}\Omega$

Check spark plug leads for damage (brittleness, cracks etc.).

If ignition coil is not within specification, or spark plug lead is damaged, it must be replaced.

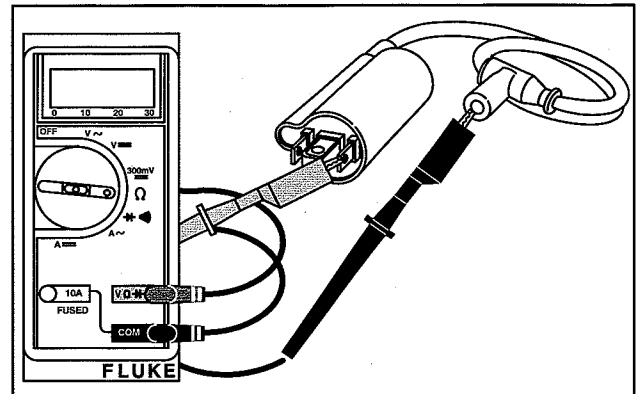

Fig. 8 – Testing Ignition Coil Secondary

14 AMP CHARGING SYSTEM

The 14 amp charging system consists of two components:

1. The belt driven permanent magnet alternator produces AC voltage, Fig. 9. AC output will vary with engine RPM, from approximately 7 volts AC at 1000 RPM to 32 volts AC at 3000 RPM.

NOTE: A loose V-belt will cause low AC output.

Belt deflection limit is 10.0-12.0 mm/10 kg (3/8-1/2 in/22 lb).

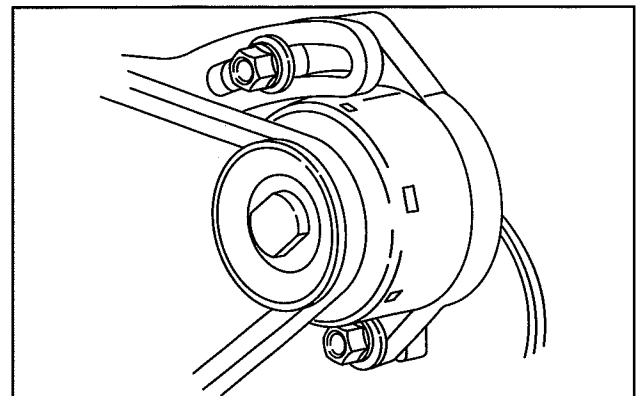

Fig. 9 – 14 Amp Alternator

2. The regulator-rectifier converts the AC current to DC and regulates current to the battery, Fig. 10. The charging rate will vary with engine RPM. The regulator-rectifier is equipped with a charging indicator light circuit.

NOTE: The regulator-rectifier requires a minimum battery voltage of 6 volts to function. **There will be no charging output if battery voltage is below 6 volts.**

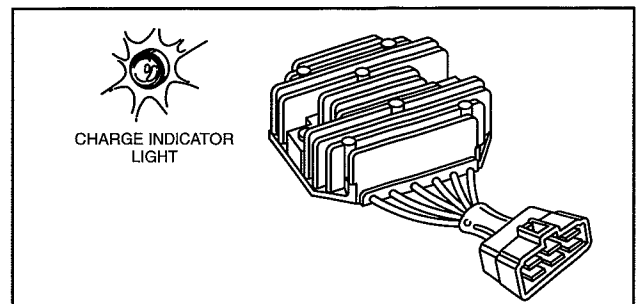
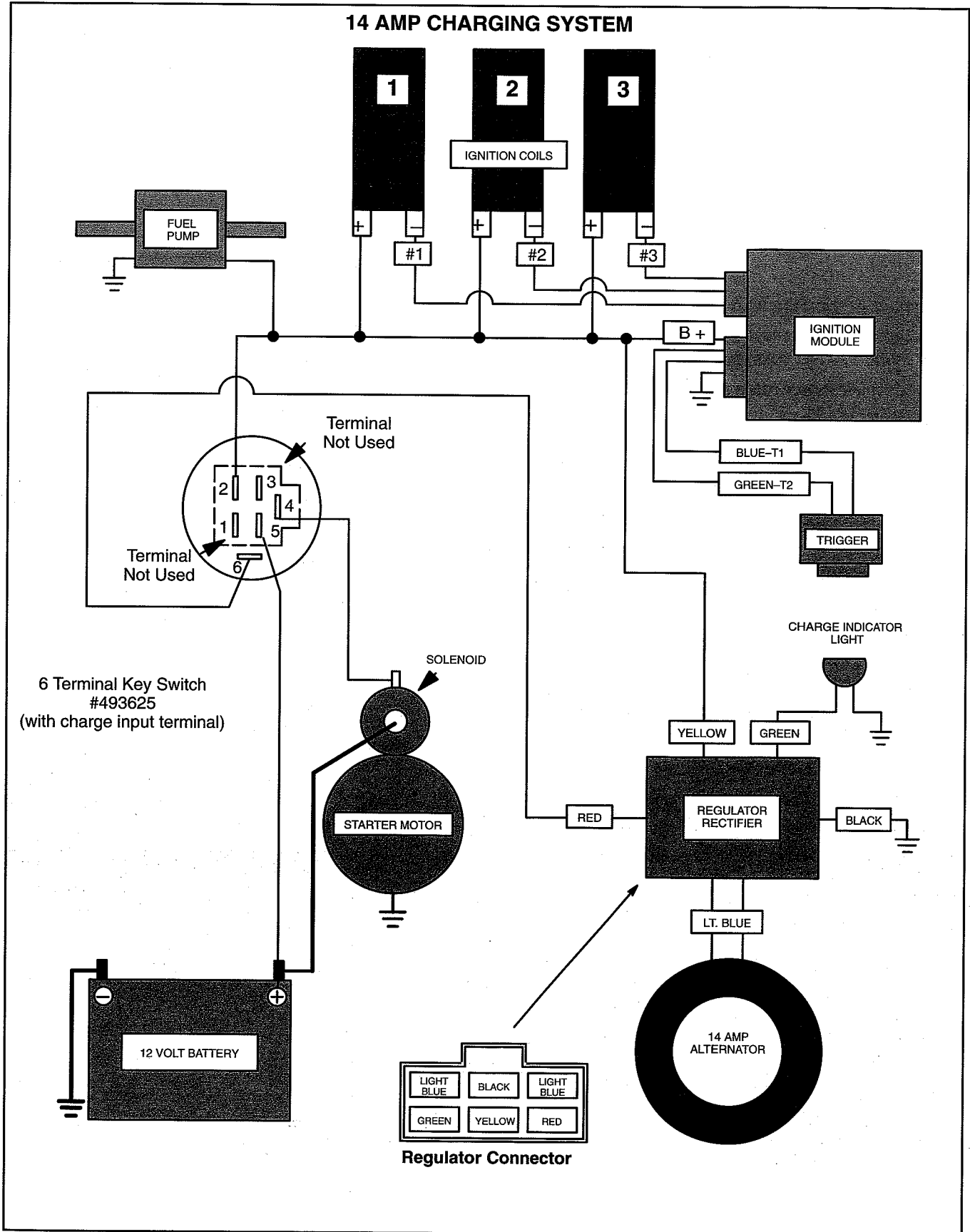

Fig. 10 – Regulator-Rectifier

14 AMP CHARGING SYSTEM



ELECTRICAL SYSTEM

TEST EQUIPMENT

The digital multimeter, Tool #19390 and the DC shunt, Tool #19468, Fig. 11, are required to test the charging system.

NOTE: The digital multimeter will withstand DC input of 10-20 amps for up to 30 seconds. To avoid blowing fuse in meter, the DC shunt is required.

Replacement fuse is available from your Briggs & Stratton source of supply. Order Part No. 19449.

TESTING ALTERNATOR – AC OUTPUT

The alternator output test will be performed with the meter in the V~ (AC volts) position, Fig. 12.

Disconnect alternator wires at connector.

Attach meter test leads to alternator output connectors BEFORE starting engine, Fig. 12.

1. With the engine running at 3300 RPM the output should be no less than 28 volts AC.
 - a. If no output or low output is found, replace alternator.
 - b. If alternator output is within specification, re-connect alternator wires and test regulator rectifier.

TESTING REGULATOR-RECTIFIER – DC OUTPUT

The DC Shunt **must** be installed on the **negative (-)** terminal of the battery, Fig. 13. All connections must be clean and tight for correct amperage readings.

Attach meter test leads BEFORE starting engine.

The regulator-rectifier test will be performed with the meter in the **300mV** position.

1. Attach RED meter test lead to RED post terminal on shunt.
2. Attach BLACK meter test lead to BLACK post terminal on shunt.

3. With the engine running at 3300 RPM, the output should be:

*** 4 – 14 Amps**

* Depending upon battery voltage and/or current draw on system.

4. If no or low output is found, be sure that regulator-rectifier is grounded properly and all connections are clean and secure. If there is still no or low output, replace the regulator-rectifier.

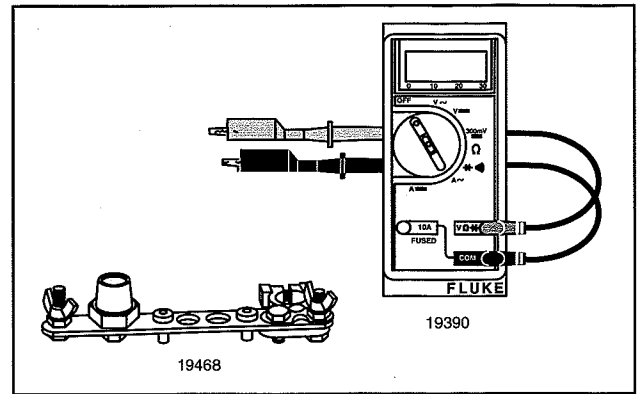

Fig. 11 – Test Equipment

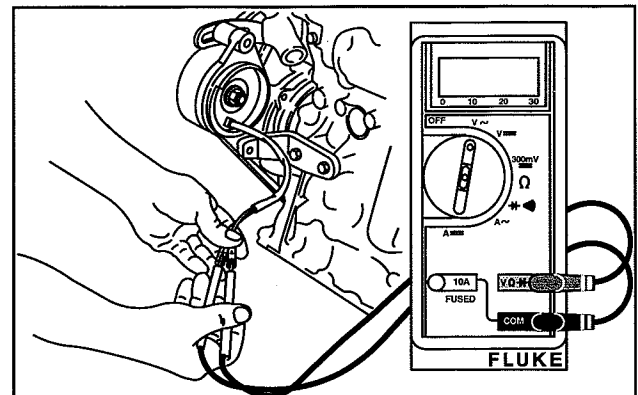

Fig. 12 – Testing Alternator Output

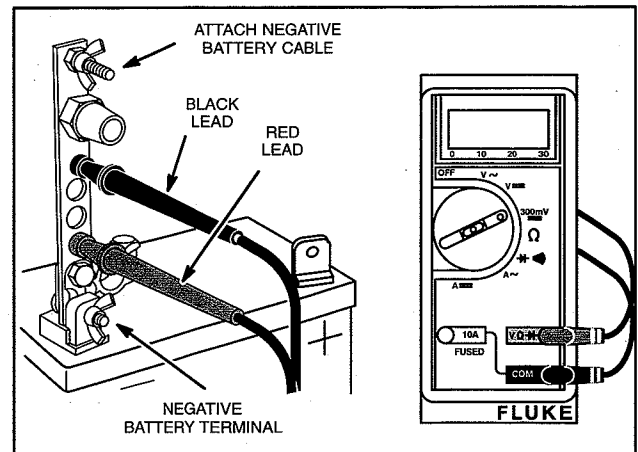

Fig. 13 – DC Shunt Installation

CHARGING INDICATOR CIRCUIT

The green wire from the regulator-rectifier is used to activate the charging indicator light. With the keyswitch in the ON position and the engine not running the charge indicator light should light, Fig. 14. With the engine running the light should go out, indicating that the battery is being charged.

If the charge indicator light does not light when the keyswitch is in the ON position (engine not running), check the bulb and wiring.

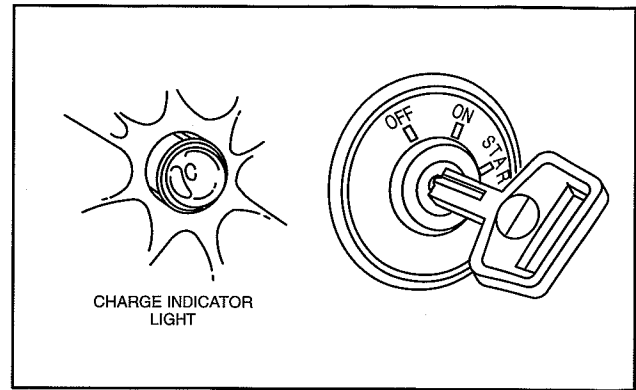

Fig. 14 – Charge Indicator Light

TESTING CHARGING INDICATOR BULB AND WIRING

The following test will be made with the meter in the "Diode Test Position" \rightarrow $\left(\text{diode symbol} \right)$, Fig. 15.

With meter selector switch in \rightarrow $\left(\text{diode symbol} \right)$ position, a continuous tone indicates continuity (complete circuit). No tone indicates no continuity (incomplete circuit). An incomplete circuit will be displayed as "OL."

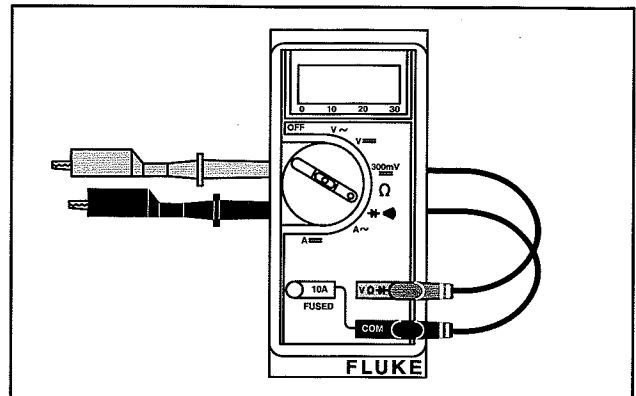

Fig. 15 – Meter Setting

Keyswitch must be in OFF position.

1. Disconnect output harness at regulator-rectifier.
2. Check continuity between charging indicator wire (green) and ground, Fig. 16.
 - a. If meter indicates continuity, bulb and wiring are OK. Replace regulator-rectifier.
 - b. If meter indicates NO continuity, replace bulb and re-test.
 - c. If meter indicates NO continuity with new bulb, the problem must be a broken wire (open circuit) in the charging indicator circuit.

If the charge indicator light remains on with the engine running, test the regulator-rectifier DC output. If output is within specification and charge indicator light remains on, replace the regulator-rectifier.

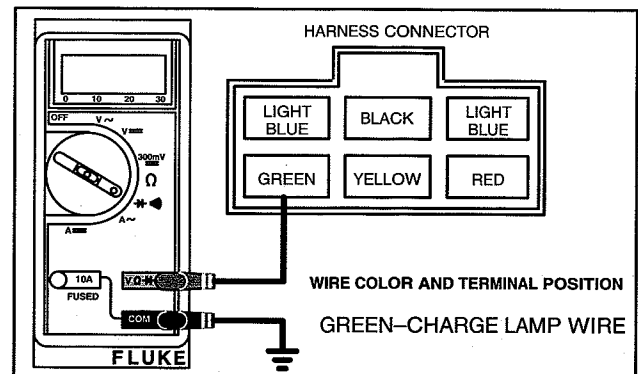

Fig. 16 – Testing Bulb And Wiring

40 Amp Charging System

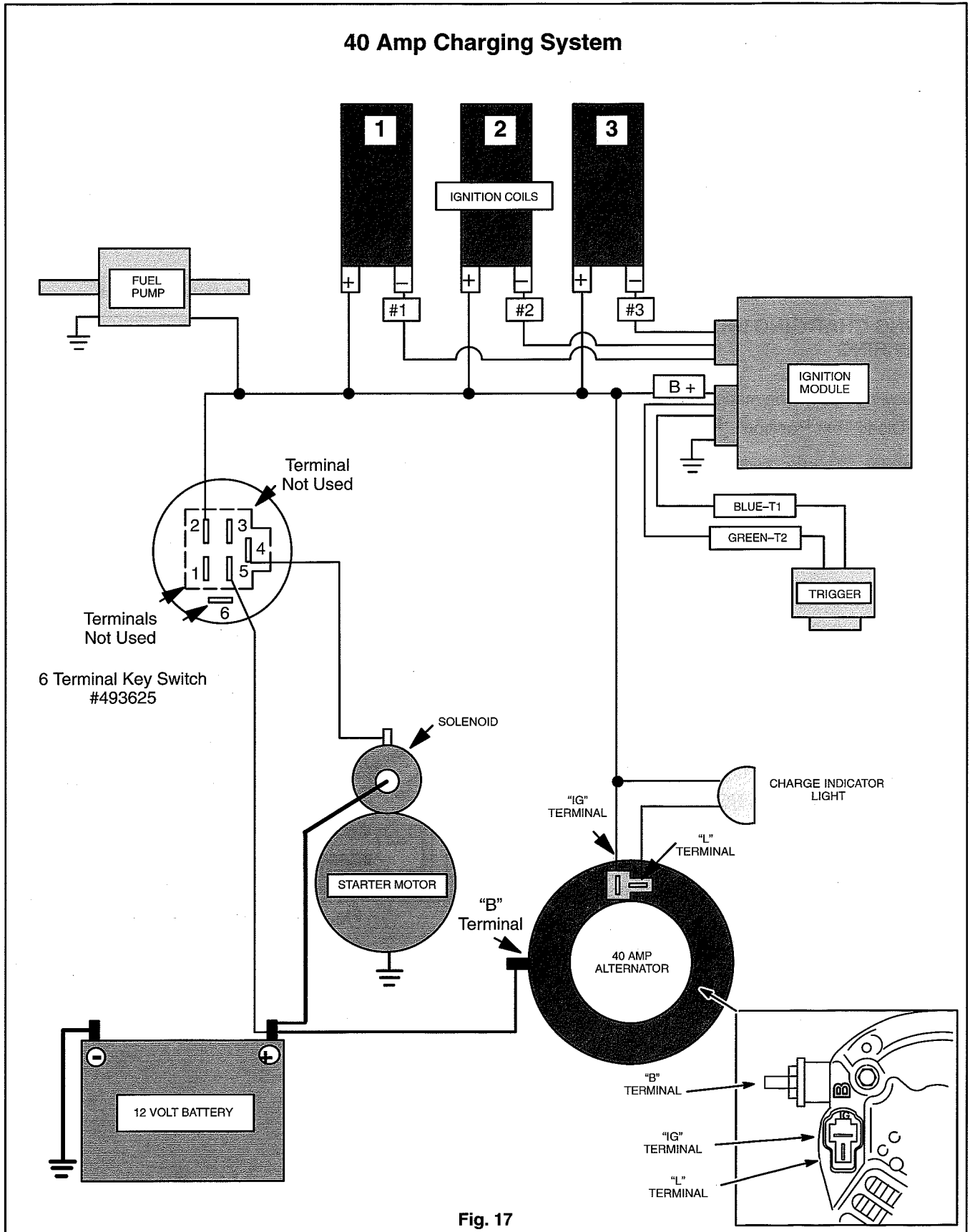

Fig. 17

40 AMP CHARGING SYSTEM

Fig. 17 shows wiring diagram for 40 amp charging system.

The 40 amp charging system consists of a belt driven, internally regulated alternator, Fig. 18.

The alternator contains a charge light circuit ("L" terminal). With the keyswitch in the ON position and the engine not running the charge indicator light should light. With the engine running the light should go out, indicating that the battery is being charged.

If the charge indicator light does not light when the keyswitch is in the ON position (engine not running), check the bulb and wiring.

NOTE: A loose V-belt will cause low DC output.

Belt deflection limit is 10.0-12.0 mm/10 kg
(3/8-1/2 in/22 lb).

TEST EQUIPMENT

The digital multimeter, Tool #19390 and the DC shunt, Tool #19468, Fig. 19, are required to test the charging system.

NOTE: The digital multimeter will withstand DC input of 10-20 amps for up to 30 seconds. To avoid blowing fuse in meter, the DC shunt is required

Replacement fuse is available from your Briggs & Stratton source of supply. Order Part No. 19449.

TESTING ALTERNATOR – DC OUTPUT

The DC Shunt **must** be installed on the **negative (-)** terminal of the battery, Fig. 20. All connections must be clean and tight for correct amperage readings.

Attach meter test leads **BEFORE** starting engine.

The regulator-rectifier test will be performed with the meter in the **300mV** position.

1. Attach RED meter test lead to RED post terminal on shunt.
2. Attach BLACK meter test lead to BLACK post terminal on shunt.
3. With the engine running at 2000 RPM, the output should be:

* 4 – 20 Amps

* Depending upon battery voltage and/or current draw on system.

4. If no or low output is found, be sure that all connections are clean and secure.
5. If all connections are OK, replace or repair the alternator.

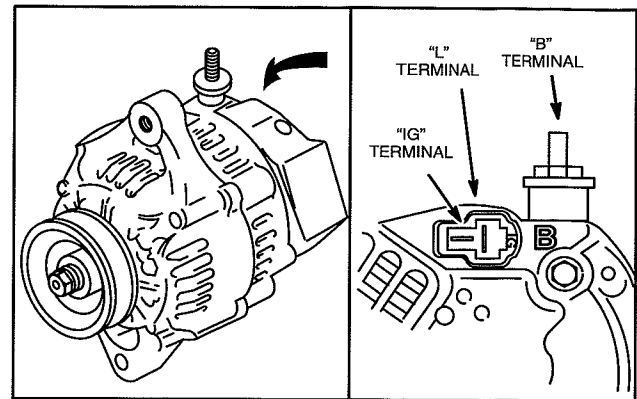

Fig. 18 – 40 Amp Alternator

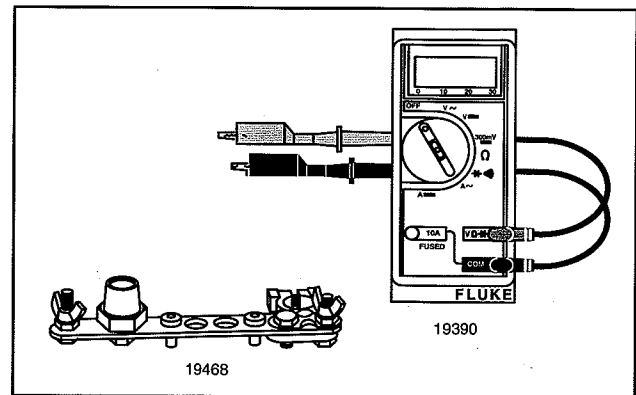

Fig. 19 – Test Equipment

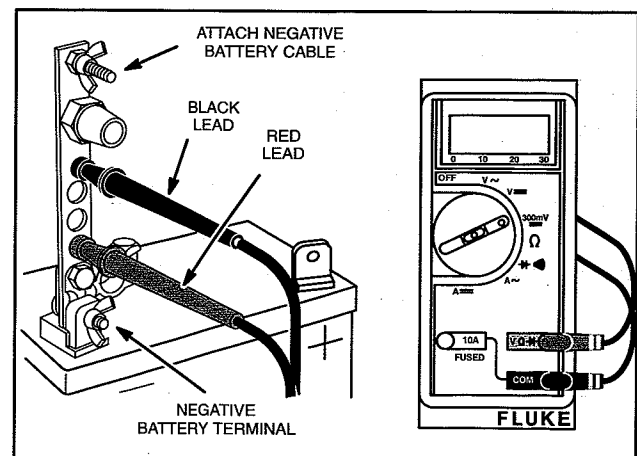

Fig. 20 – DC Shunt Installation

ELECTRICAL SYSTEM

DISASSEMBLE ALTERNATOR

1. Remove pulley nut using tool #SST and 10 mm deep socket as shown in Fig. 21.
 - a. Remove pulley and spacer.

Replace pulley if damaged or worn.

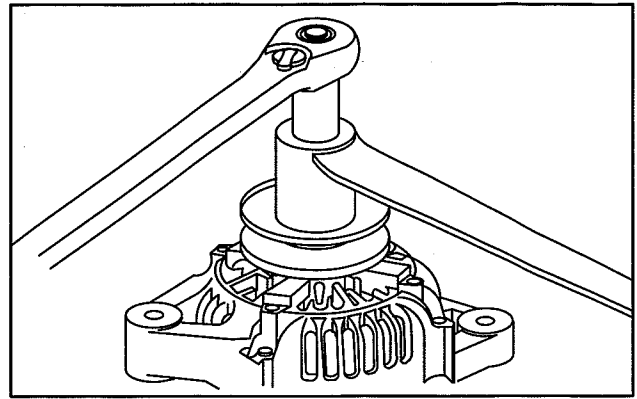

Fig. 21 – Remove Pulley

2. Remove nut and insulator at "B" terminal.
3. Remove three screws and brush cover, Fig. 22.

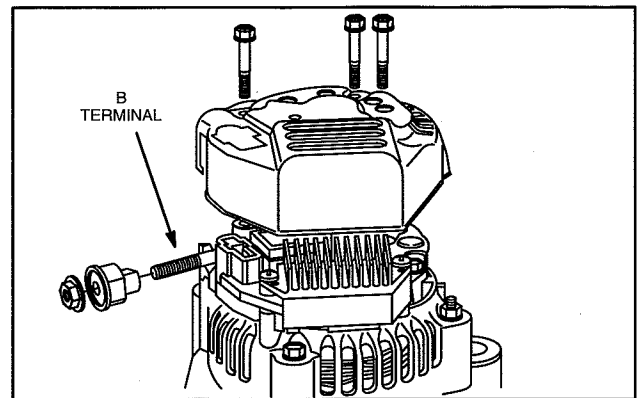

Fig. 22 – Remove Rear Cover

4. Remove two screws, then brush retainer assembly, Fig. 23.

Important: Length of brush retainer screws are different. Do not mix.
Screw "A" – 11.5 mm
Screw "B" – 9.0 mm

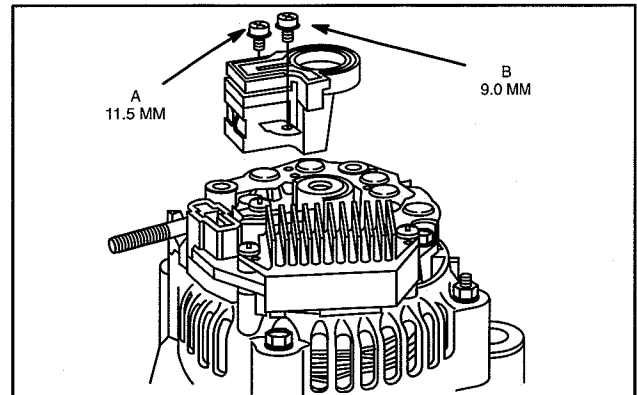

Fig. 23 – Remove Brush Retainer

5. Remove three screws and regulator, Fig. 24.

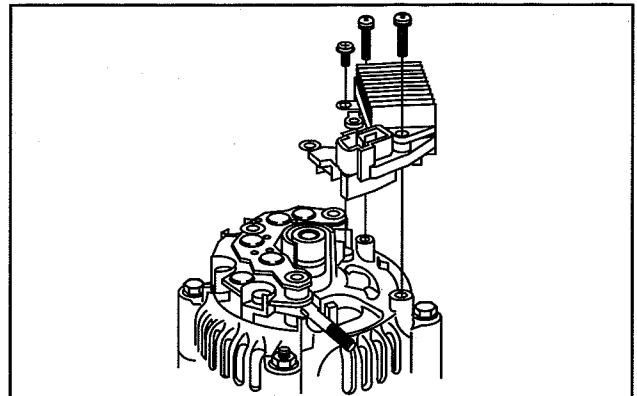

Fig. 24 – Remove Regulator

6. Remove four stator lead screws from rectifier, Fig. 25.
 - a. Carefully straighten stator leads.
 - b. Remove rectifier.

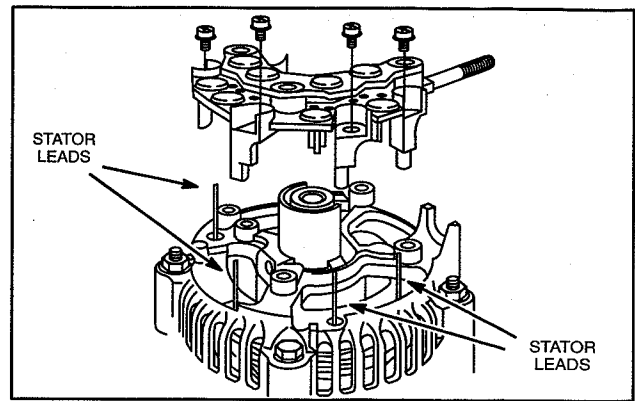

Fig. 25 – Remove Rectifier

7. Scribe or place a reference mark on drive end and brush end housing so that they may be re-assembled in original position.
8. Remove two nuts and two thru bolts.
9. Remove brush end housing being careful not to damage stator leads, Fig. 26.

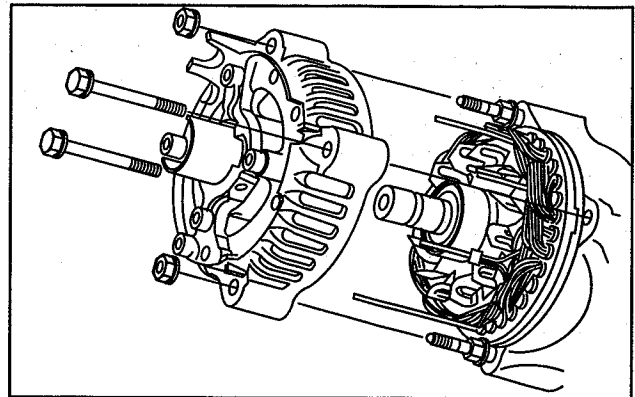

Fig. 26 – Remove Brush End Housing

10. Remove rotor from drive end housing, Fig. 27.
- NOTE:** Stator is NOT removable.

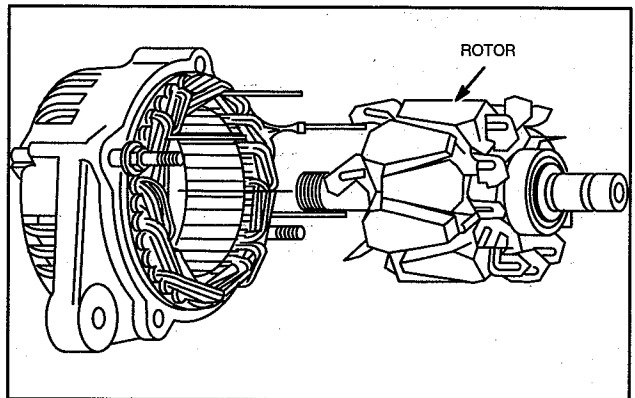

Fig. 27 – Remove Rotor

CHECKING BEARINGS

Ball bearings must rotate freely. If any rough spots are felt the ball bearing must be replaced.

NOTE: Rotor and ball bearing are an assembly. If bearing is worn, replace rotor assembly.

Remove Ball Bearing

1. Remove four screws and bearing retainer, Fig. 28.
2. Support drive housing on blocks.
3. Press out bearing from pulley side of drive end housing using driver #19416.

DO NOT re-use ball bearings that have been removed from drive end housing. The bearing races are usually damaged during removal.

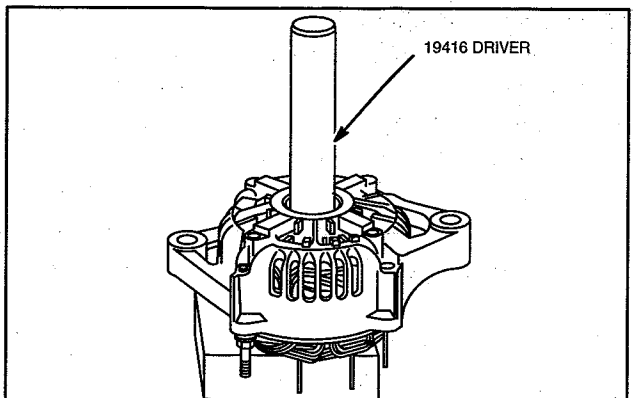

Fig. 28 – Remove Bearing Retainer

ELECTRICAL SYSTEM

INSTALL BALL BEARING

1. Lightly lubricate bearing O.D. with engine oil.
2. Press in new bearing using bearing driver #19226, Fig. 29.
3. Install retainer and four screws.

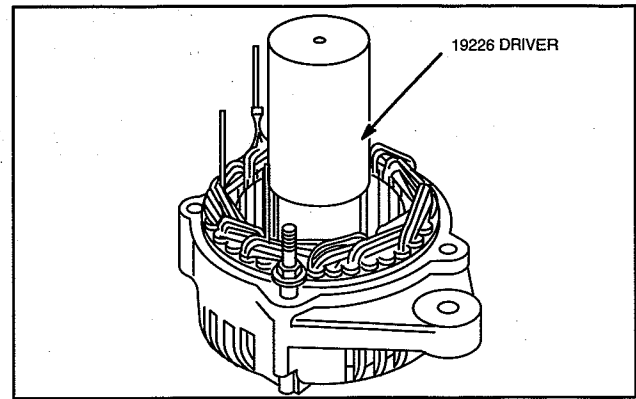

Fig. 29 – Install Ball Bearing

CHECKING ROTOR

The following test will be made with the meter in the "Diode Test Position" $\rightarrow + \text{|||}$.

1. Use digital multimeter and check for continuity between slip rings as shown, Fig. 30.
 - a. Meter should make continuous tone (continuity).
 - b. If meter displays "OL," (no continuity) replace rotor.
2. Check for continuity between slip ring and rotor shaft.
 - a. Meter should display "OL," (no continuity).
3. Measure slip ring diameter, Fig. 31.

STD: 14.4 mm (.567")

Reject: 14.0 mm (.551")

Slip rings may be cleaned with fine sandpaper (#300 – 500 grit).

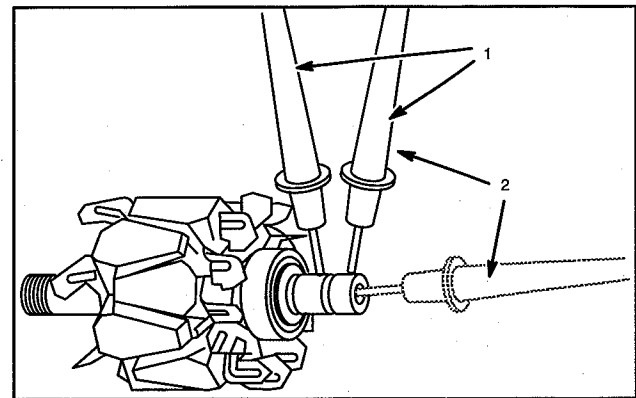

Fig. 30 – Check Rotor

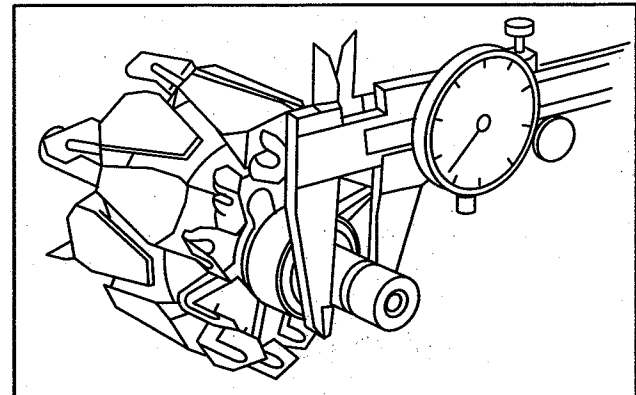

Fig. 31 – Check Slip Ring

CHECK BRUSHES

Measure length of brushes protruding from brush holder, Fig. 32.

STD: 10.5 mm (.413")

Reject: 8.0 mm (.315")

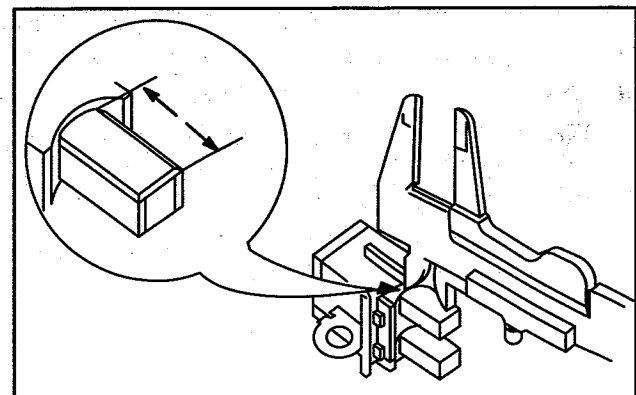



Fig. 32 – Check Brushes

CHECK REGULATOR

The following test will be made with the meter in the "Diode Test Position" \rightarrow .

1. Attach BLACK meter test lead to terminal "A" as shown, Fig. 33.
2. Contact terminal "B" with RED meter test lead, Fig. 33.
 - a. Meter should "beep" once.
 - b. If meter displays "OL" or makes a continuous tone, regulator is defective. Replace regulator.

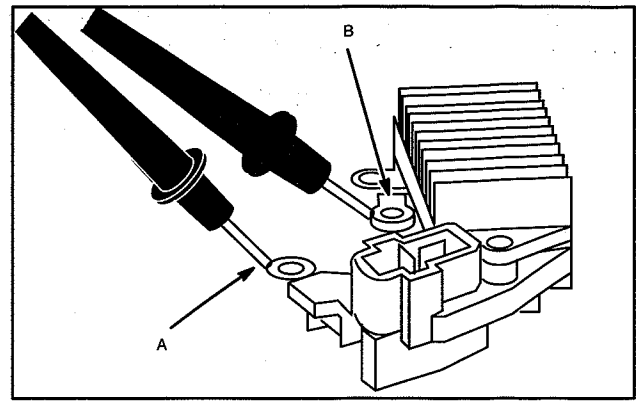



Fig. 33 – Check Regulator

CHECK RECTIFIER

The following test will be made with the meter in the "Diode Test Position" \rightarrow .

1. Attach BLACK meter test lead to "B" terminal, Fig. 34. Leave attached through Step 3.
2. Contact #1 terminal with RED meter test lead, Fig. 34.
 - a. Meter should "beep" once.
 - b. If meter displays "OL" or makes a continuous tone, diode is defective. Replace rectifier.
3. Repeat test at #2, #3 and #4 terminals.
 - a. Results must be the same.
4. Attach RED test lead to one of the three rectifier mounting holes, Fig. 35. Leave attached through Step 6.
5. Contact #1 terminal with BLACK meter test lead, Fig. 35.
 - a. Meter should "beep" once.
 - b. If meter displays "OL" or makes a continuous tone, diode is defective. Replace rectifier.
6. Repeat test at #2, #3 and #4 terminals.
 - a. Results must be the same.

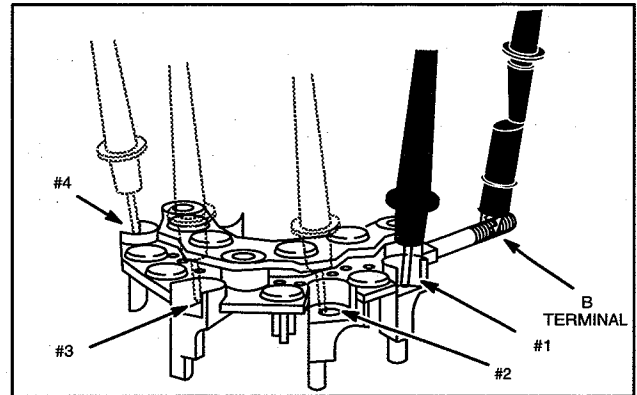

Fig. 34 – Check Rectifier

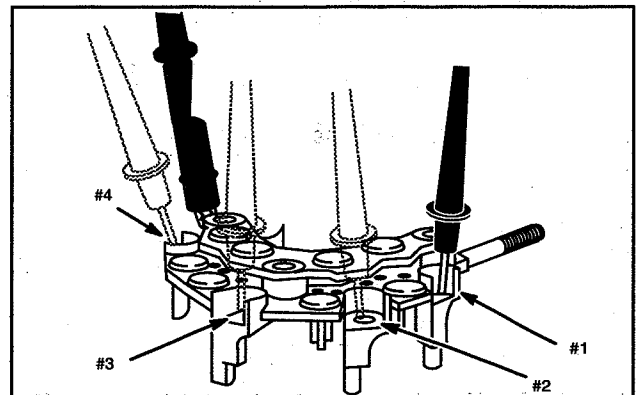

Fig. 35 – Check Rectifier

ASSEMBLE ALTERNATOR

1. Assemble rotor to drive end housing, Fig. 36.
2. Assemble spacer, pulley and nut to rotor shaft.
 - a. Do not tighten nut at this time.
 - b. Place pulley side down on work surface.

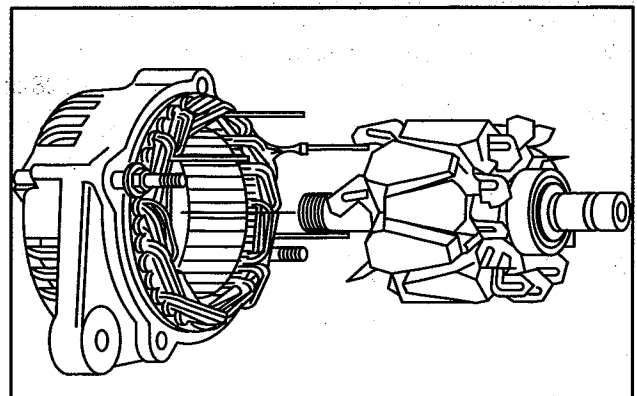

Fig. 36 – Installing Rotor

ELECTRICAL SYSTEM

3. Assemble brush end housing to drive end housing with reference marks aligned, Fig. 37.

NOTE: Do not damage stator leads.

4. Install thru bolts and nuts.
 - a. Torque to 5.0 Nm (45 in. lbs.).

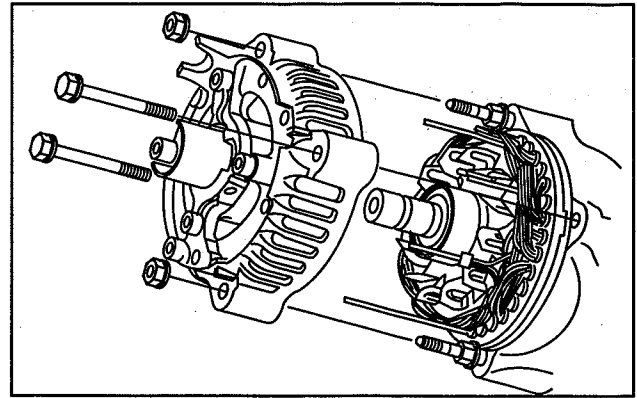

Fig. 37 - Assemble Housings

5. Align stator wires with holes in rectifier and assemble rectifier to brush end housing, Fig. 38.
6. Carefully form a "U" bend in stator wires.
 - a. Install screws and tighten securely.

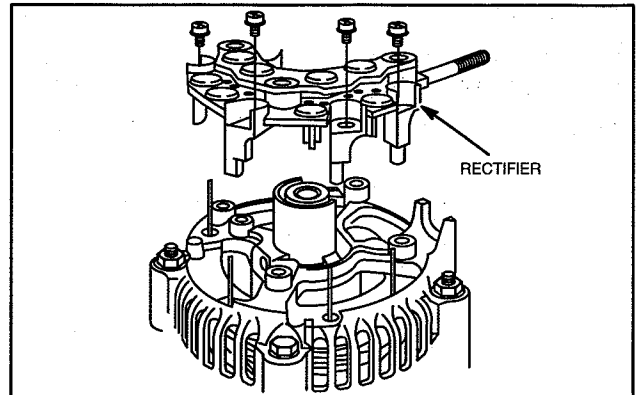

Fig. 38 - Install Rectifier

7. Install regulator with three screws shown, Fig. 39.

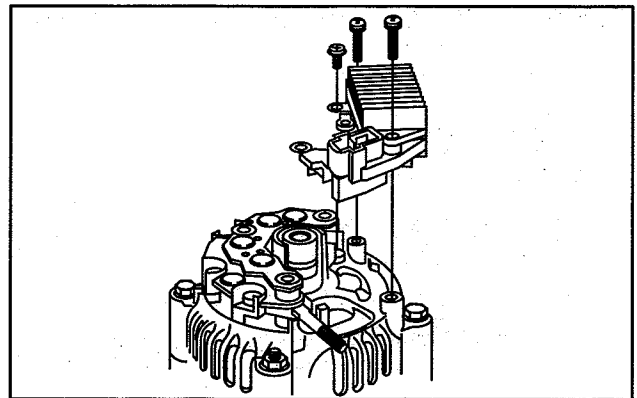

Fig. 39 - Install Regulator

8. Assemble cover to brush holder, Fig. 40.

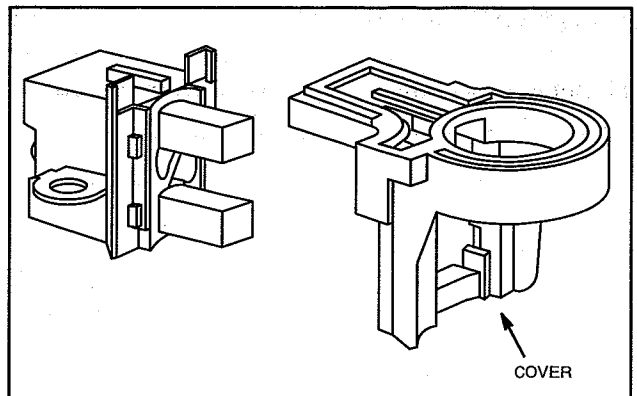

Fig. 40 - Install Brush Cover

9. Install brush holder.

Important: Length of brush retainer screws are different. Install as shown.
Screw "A" – 11.5 mm
Screw "B" – 9.0 mm

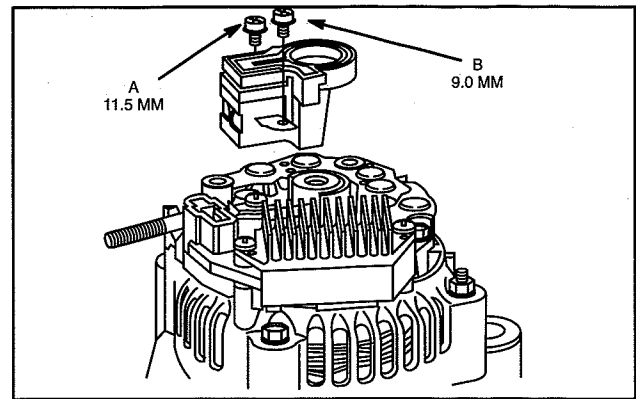

Fig. 41 – Install Brush Holder

10. Install rear cover and three screws, Fig. 42.

- a. Torque screws to 3.0 Nm (25 in. lbs.).

11. Install insulator and nut.

- a. Torque nut to 4.0 Nm (35 in. lbs.).

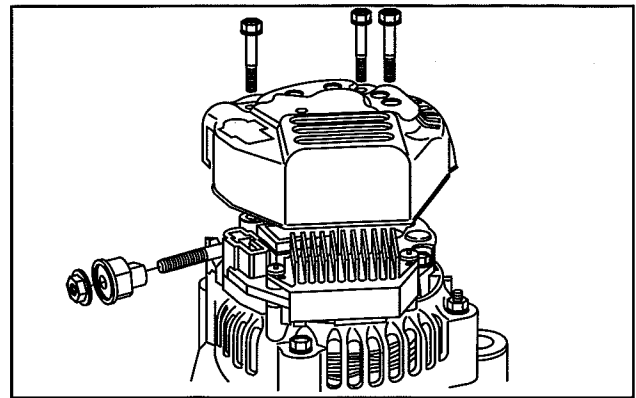

Fig. 42 – Install Cover

Torque drive pulley using the following procedure, Fig. 43.

1. Hold nut with SST #.
2. With torque wrench, turn 10 mm deep socket COUNTERCLOCKWISE.
 - a. Torque to 70.0 Nm (50 ft. lbs.).

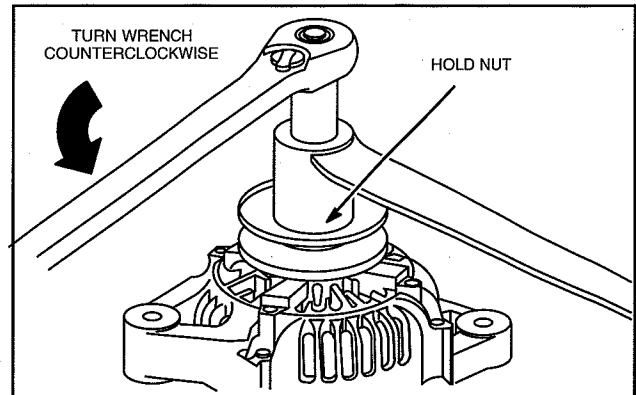

Fig. 43 – Torque Pulley

ELECTRICAL SYSTEM

STARTER SYSTEM

The starter system consists of a 12 volt automotive type electric starter with a solenoid, Fig. 44. When the solenoid is activated, the drive lever moves the pinion gear into engagement with the flywheel ring gear and allows battery current to flow to the starter motor and crank the engine.

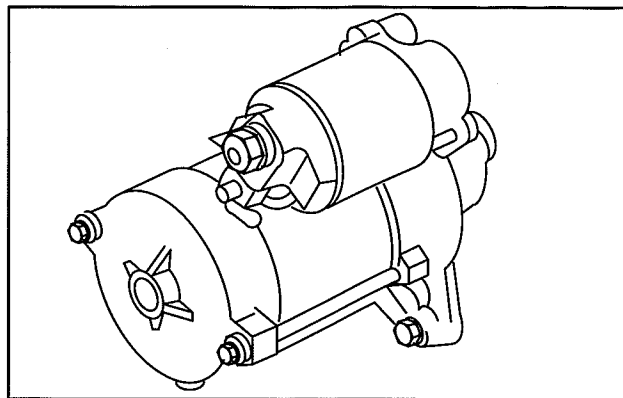

Fig. 44 – 12 Volt Starter And Solenoid

STARTER CURRENT DRAW TEST

Important: When making the starter current draw test make sure that all parasitic load is removed from the engine and that engine has the correct viscosity oil. Engine temperature should be at least 21° C (70° F).

Make sure battery and solenoid connections are clean and tight.

NOTE: Battery voltage must not be below 11.7 volts.

TEST EQUIPMENT

The following equipment is required to test current draw of starter, Fig. 45.

1. Digital multimeter, Tool #19390.
2. DC shunt, Tool #19468.
3. Two battery cables with alligator clips.
4. One jumper wire with alligator clips.
5. A fully charged 12 volt battery.

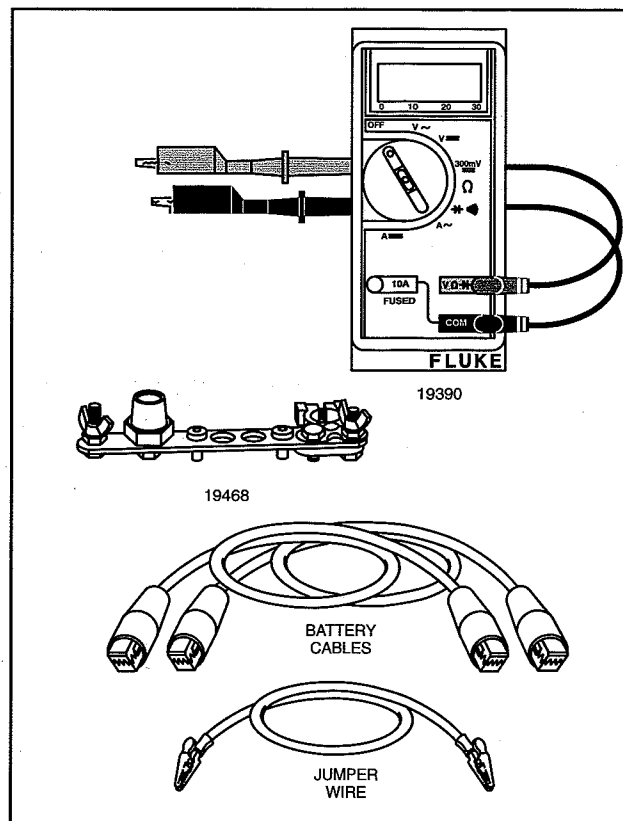

Fig. 45 – Test Equipment

TESTING STARTER

NOTE: To prevent engine from starting, remove spark plug wires from spark plugs. Leave spark plugs installed.

The starter current draw test will be performed with the meter in the **300mV** position.

The DC Shunt **must** be installed on the **negative (-)** terminal of the battery, Fig. 46.

1. Attach RED meter test lead to RED post terminal on shunt.
2. Attach BLACK meter test lead to BLACK post terminal on shunt.
3. Activate starter.
 - a. Allow 3 seconds for meter reading to stabilize.
4. **Current draw should not exceed 80 amps DC.**

If amperage draw exceeds specification, remove starter from engine and perform No Load starter current draw test.

NO LOAD STARTER CURRENT DRAW TEST

Remove starter motor.

To hold starter securely while testing, clamp starter mounting bracket in a vise. **DO NOT** clamp starter housing in a vise or field windings or magnets may be damaged.

TESTING STARTER (NO LOAD)

The No Load starter current draw test will be performed with the meter in the **300mV** position.

The DC Shunt **must** be installed on the **negative (-)** terminal of the battery, Fig. 47.

1. Attach RED meter test lead to RED post terminal on shunt.
2. Attach BLACK meter test lead to BLACK post terminal on shunt.
3. Attach negative battery cable to a good ground such as drive housing.
4. Attach positive battery cable to battery terminal on solenoid.
5. Attach one end of jumper wire to solenoid tab terminal, Fig. 47.
6. Activate starter by contacting positive battery terminal with other end of jumper wire, Fig. 47.
 - a. Allow 3 seconds for meter reading to stabilize.
7. **Current draw should not exceed 50 amps DC.**

If amperage draw exceeds specification, replace starter.

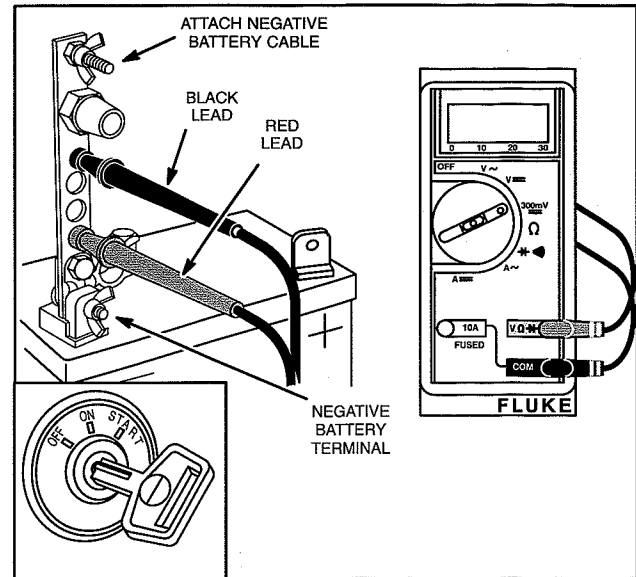

Fig. 46 – Starter Current Draw Test

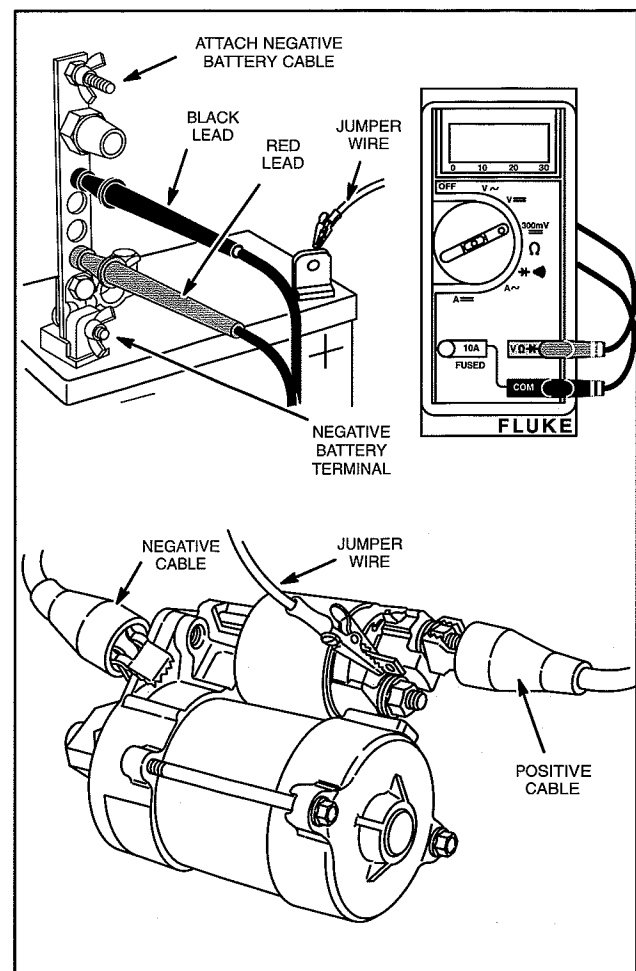

Fig. 47 – Testing Starter (No Load)

ELECTRICAL SYSTEM

EQUIPMENT TO TEST SOLENOID

The solenoid test is performed with the starter removed from the engine.

The following equipment is recommended to test the solenoid.

1. One battery cable with alligator clips, Fig. 48.
2. A jumper wire.
3. A fully charged 12 volt battery.

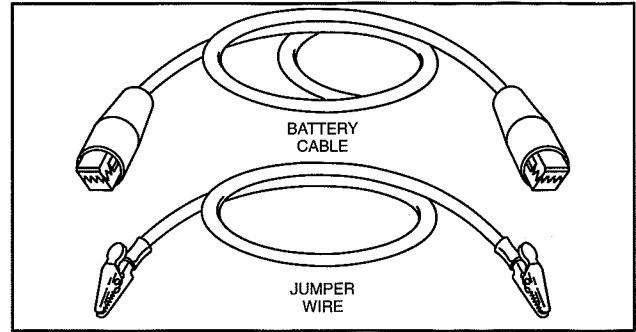

Fig. 48 – Test Equipment

TESTING SOLENOID

1. Attach one end of battery cable to negative battery terminal and other end of cable to a good ground such as drive housing, Fig. 49.
2. Attach jumper wire to tab terminal on solenoid.
3. Activate solenoid by contacting positive battery terminal with other end of jumper wire.
 - a. Pinion must move outward quickly (engage).
4. Remove jumper wire from positive battery terminal.
 - a. Pinion must return quickly (disengage).

If pinion does not move, replace the solenoid. If pinion moves slowly, check for dirty or damaged helix.

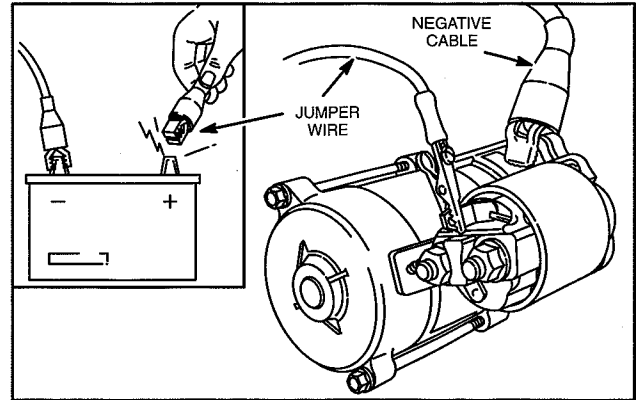

Fig. 49 – Testing Solenoid

REPLACING SOLENOID

1. Remove nut and field coil wire from stud terminal, Fig. 50.
2. Remove solenoid mounting nuts and solenoid.
3. Lift solenoid to disengage drive lever from plunger.

NOTE: Hold starter in vertical position with drive housing side down when removing and installing solenoid.

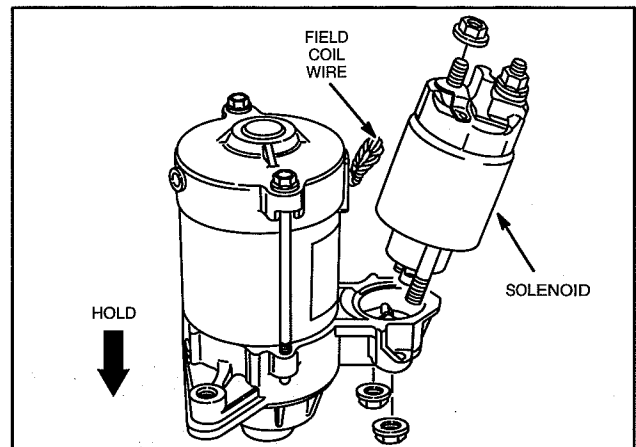

Fig. 50 – Removing Solenoid

Small hole in rubber dust cover must face starter.

4. Engage flats on plunger with fork in drive lever and assemble solenoid to starter, Fig. 51.
 - a. Torque nuts to 8.0 Nm (70 in. lbs.).
5. Install field coil wire and nut.
 - a. Torque nut to 10.0 Nm (90 in. lbs.).
6. Install starter motor.
 - a. Torque screws to 40.0 Nm (30 ft. lbs.).

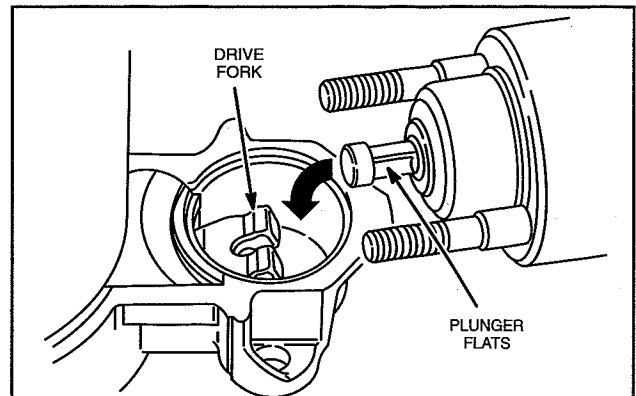

Fig. 51 – Installing Solenoid

REMOVING PINION GEAR ASSEMBLY

1. Remove solenoid.
2. Remove starter thru bolts.
3. Place starter on bench with drive housing up.
4. While holding starter housing, lift off drive end housing with drive lever, Fig. 52.

DO NOT separate housing from brush end cap or allow armature to move up or it will be necessary to re-assemble brushes.

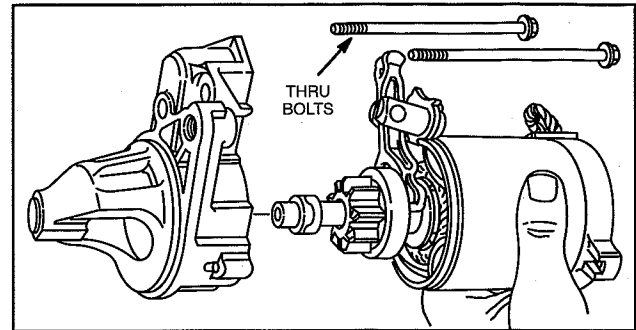

Fig. 52 – Removing Drive Housing

5. Separate split retainer using small screw driver and remove upper retainer, Fig. 53.
6. Use a 14 mm deep socket and drive lower retainer from snap ring, Fig. 53.

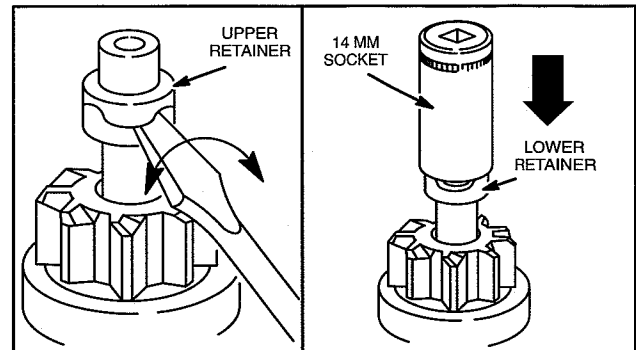

Fig. 53 – Removing Split Retainer

7. Pry off snap ring using small screw driver, Fig. 54.
8. Remove and discard lower and upper retainer and snap ring.

Always use a new snap ring and split retainer.

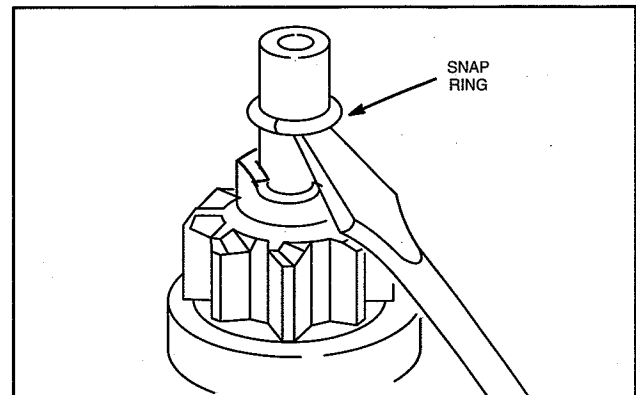

Fig. 54 – Removing Snap Ring

9. Remove pinion gear and clutch assembly, Fig. 55. Clean and inspect helix. If helix is damaged, replace armature.

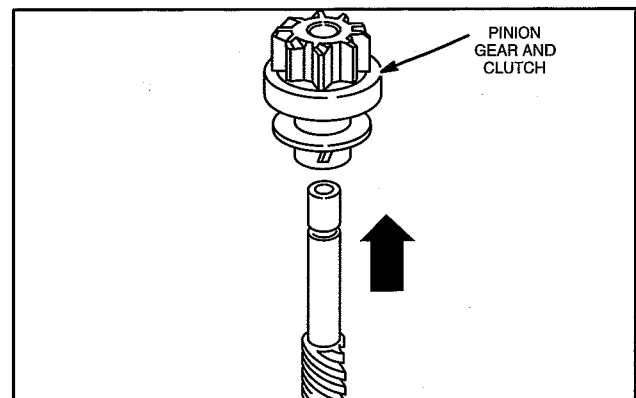

Fig. 55 – Removing Pinion And Clutch

ELECTRICAL SYSTEM

INSTALL PINION GEAR ASSEMBLY

1. Lubricate helix with a light coat of grease and assemble pinion gear and clutch.
2. Assemble new lower retainer to shaft, Fig. 56.
3. Install new snap ring.

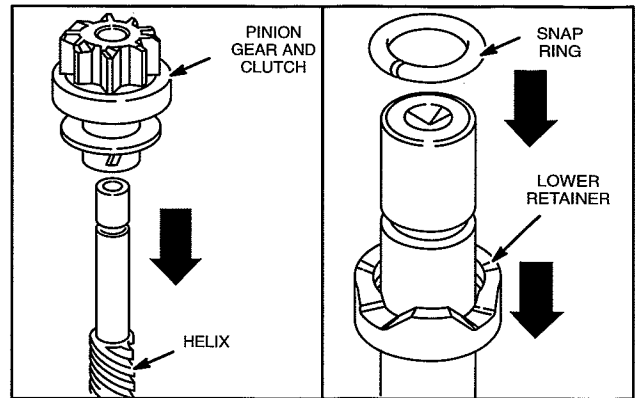

Fig. 56 – Installing Pinion Gear

4. Pull up on lower retainer until snap ring snaps into groove in retainer.
5. Install new upper retainer. Push on upper retainer until snap ring snaps into groove in retainer, Fig. 57.

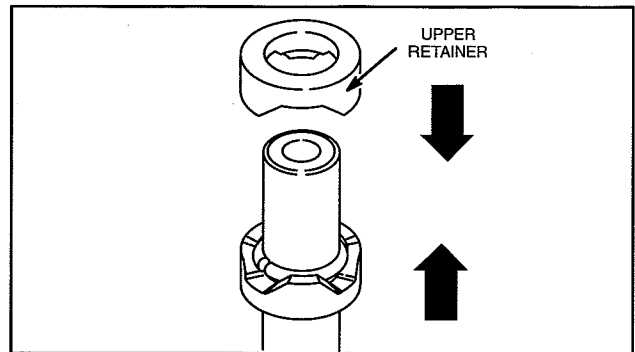

Fig. 57 – Assembling Retainer

6. Align tab on drive lever with notch in housing, Fig. 58.

NOTE: Rubber seal on drive lever support must face end cap.

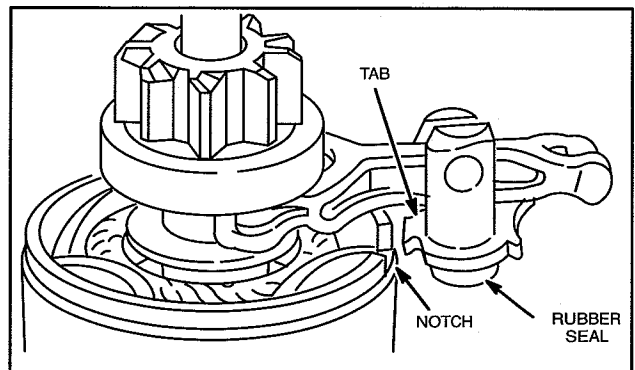

Fig. 58 – Installing Drive Lever

7. Install drive housing, Fig. 59.
8. Install thru bolts.
 - a. Torque thru bolts to 8.0 Nm (70 in. lbs.).
9. Install solenoid.

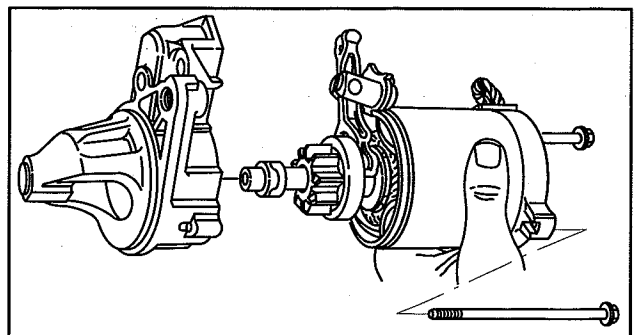

Fig. 59 – Installing Drive Housing

DISASSEMBLE STARTER MOTOR

If starter motor is to be disassembled to inspect brushes or commutator, DO NOT remove drive housing.

1. Remove solenoid.
2. Place drive housing in a vise as shown in Fig. 60.

NOTE: Take care not to damage drive housing or mounting surface.

3. Remove thru bolts and lift off end cap.

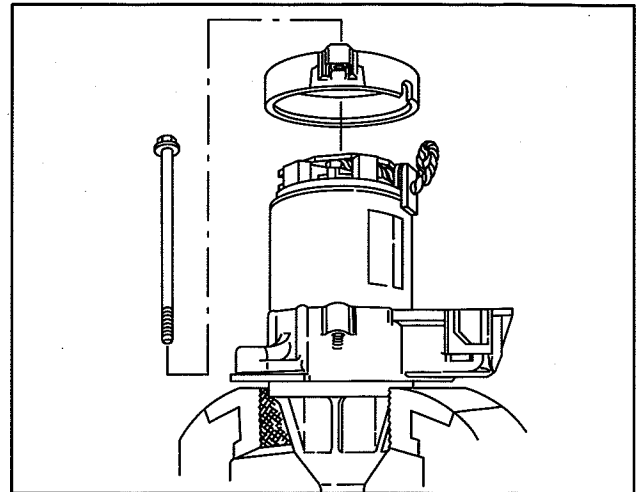

Fig. 60 – Removing End Cap

4. Remove brush retainer plate.
 - a. Note brush to commutator contact.
5. Remove brushes and springs from brush holder, Fig. 61.
6. Remove brush holder.
 - a. If brush holder or retainer plate are damaged they must be replaced.

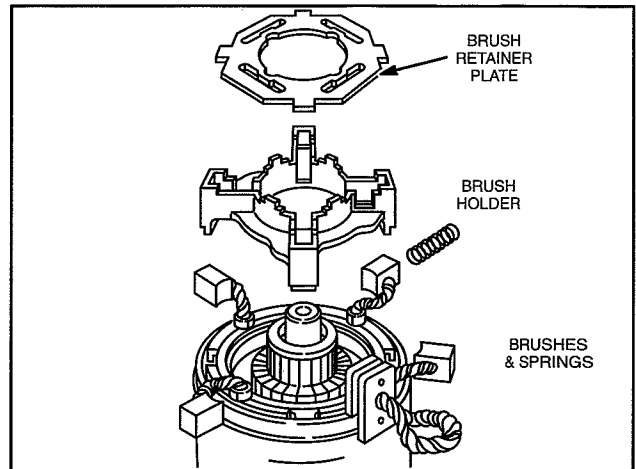

Fig. 61 – Removing brushes

7. Remove starter housing.
8. Remove armature and drive lever, Fig. 62.

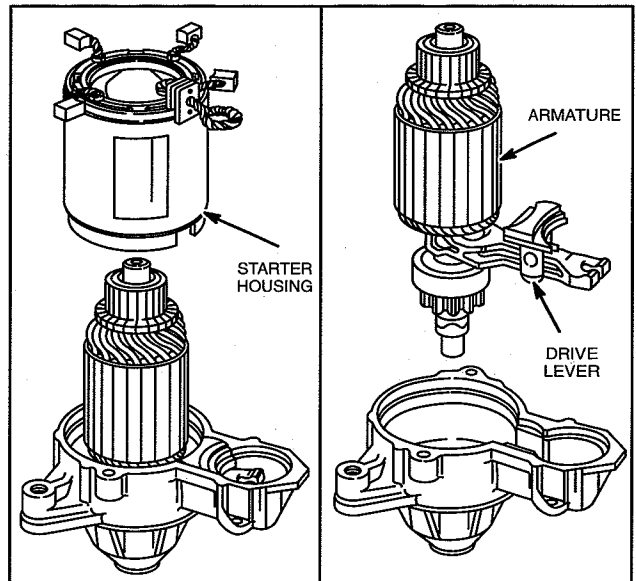

Fig. 62 – Removing Housing And Armature

ELECTRICAL SYSTEM

INSPECT ARMATURE COMMUTATOR

The armature commutator may be cleaned with fine sandpaper (#300 – 500 grit). DO NOT use emery cloth. Commutator may be machined to no less than 27.0 mm (1.062”).

Slots between commutator bars should be cleaned with a hack saw blade after cleaning or machining, Fig. 63.

The armature should be checked for shorts with a growler.

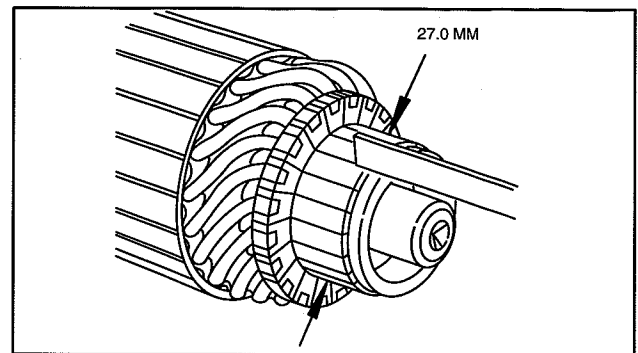

Fig. 63 – Cleaning Commutator

INSPECT BRUSHES

Minimum brush dimension is 7.5 mm (.295”), Fig. 64. If brushes are worn less than specification, replace the brushes or starter housing.

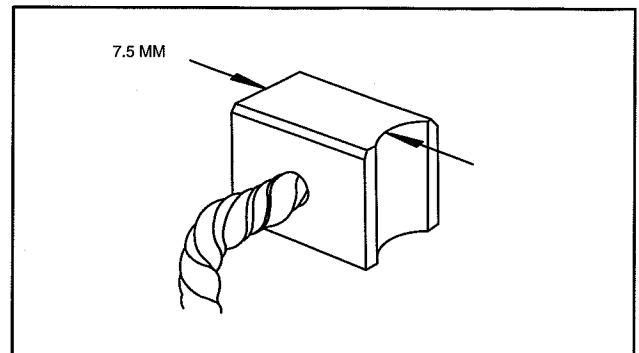

Fig. 64 – Minimum Brush Dimension

Use digital multimeter and check for continuity between field coil wire and brushes shown, Fig. 65.

The following test will be made with the meter in the “Diode Test Position” $\rightarrow \text{D}$.

1. Attach either meter test lead to field coil wire.
2. Contact first one, then other brush with other test lead as shown.
 - a. Meter should make continuous tone (continuity).
 - b. If meter does not make a tone, (no continuity) replace starter housing.

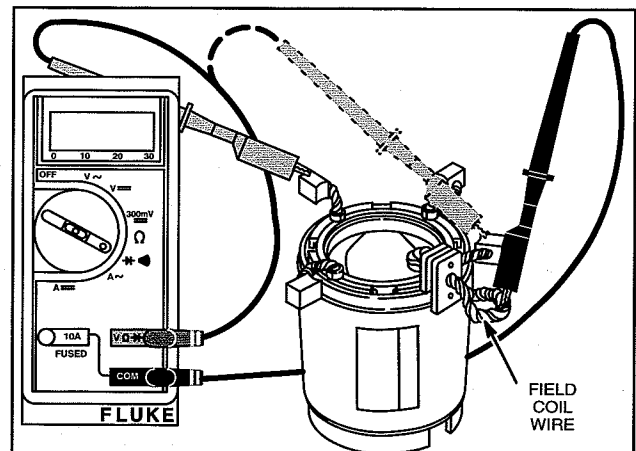

Fig. 65 – Checking Brushes

3. Attach either test lead to starter housing, Fig. 66.
4. Contact first one, then other brush with other test lead as shown.
 - a. Meter should make continuous tone (continuity).
 - b. If meter does not make a tone, (no continuity) replace starter housing.

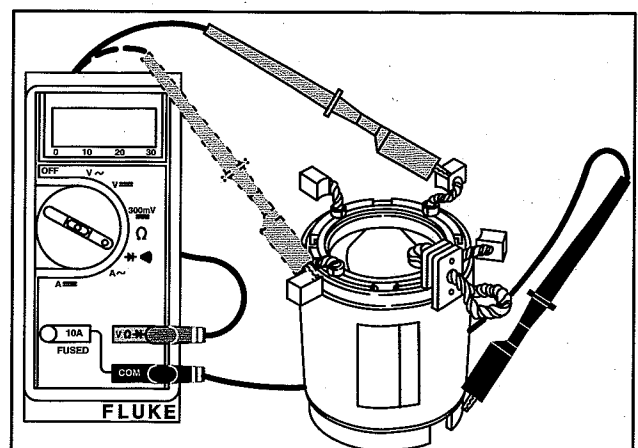

Fig. 66 – Checking Brushes

REPLACE BRUSHES

1. Cut off brush lead wires at terminals as shown.

NOTE: For purposes of identification terminals are lettered A, B, C, D.

Do not remove field wire from terminal A.

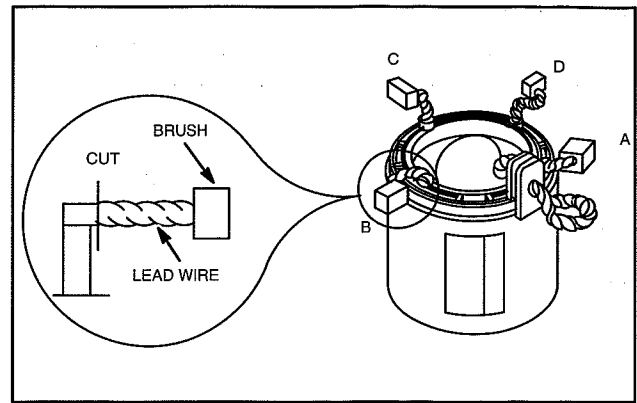

Fig. 67 – Remove Brushes

2. Use a fine file and carefully remove remaining lead wire from terminals.
 - a. Terminals B and D must be no less than specification shown.

L: 1.6 – 1.8 mm (0.063 – 0.070")

W: 6.5 – 7.5 mm (0.255 – 0.295")

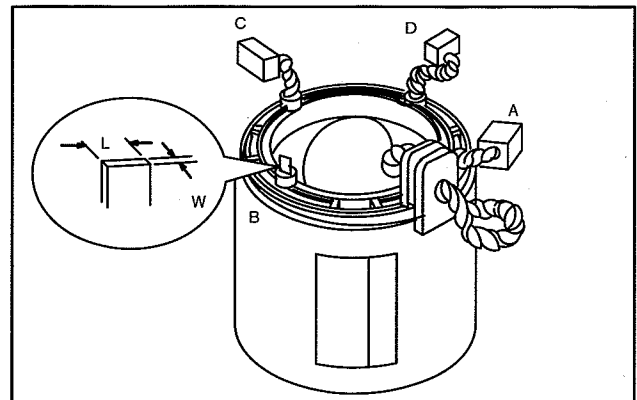

Fig. 68 – Clean Terminals

3. Crimp replacement brushes over terminals so that wires face in counterclockwise direction.

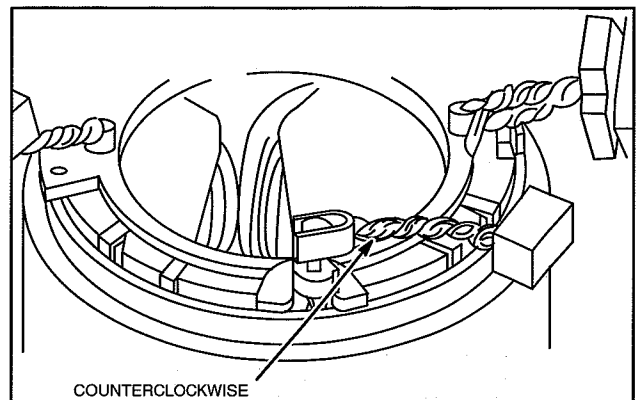

Fig. 69 – Attach Brushes

4. Solder brush lead wires to terminals.

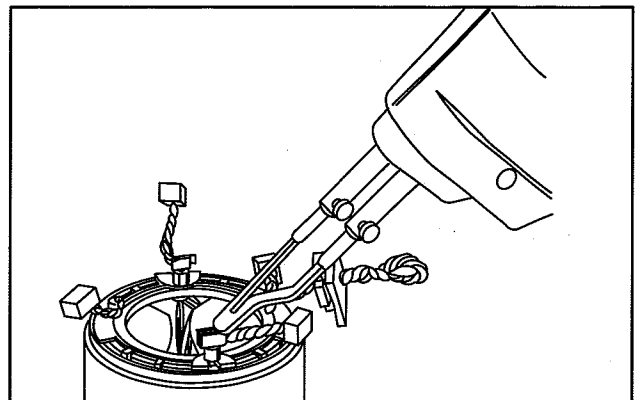

Fig. 70 – Solder Brushes

ELECTRICAL SYSTEM

ASSEMBLE STARTER

1. Assemble drive lever to pinion and install armature and drive lever into drive housing, Fig. 71.

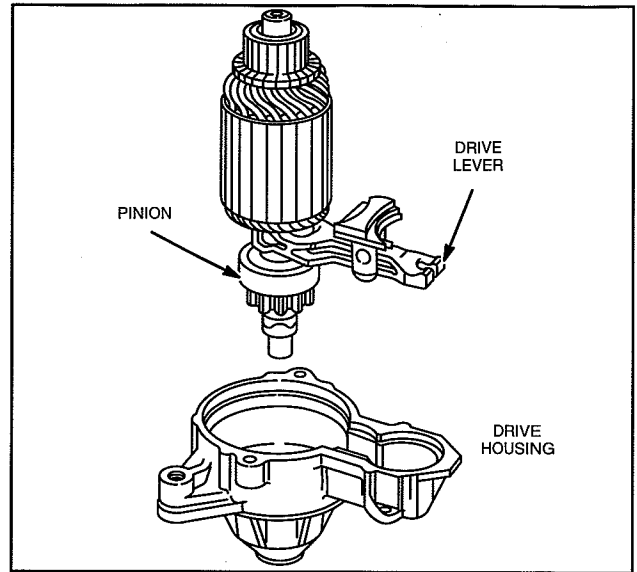

Fig. 71 – Installing Armature

2. Assemble starter housing to drive housing, aligning notch in housing with tab on drive lever support, Fig. 72.

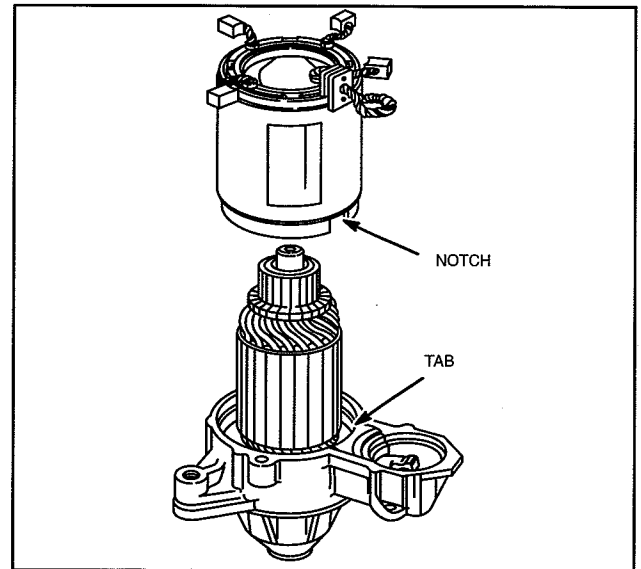

Fig. 72 – Installing Starter Housing

3. Install brush holder, inserting tabs on brush holder into slots in starter housing, Fig. 73.

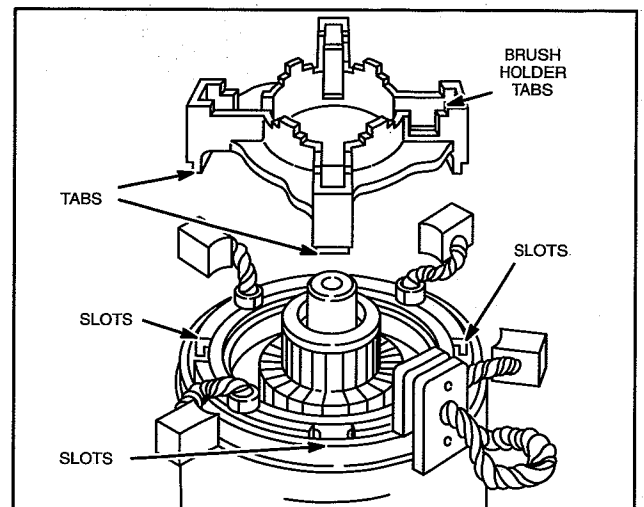

Fig. 73 – Installing Brush Holder

4. Insert brush springs.
5. Install brushes, Fig. 74.
 - a. Use a small screw driver to compress spring.

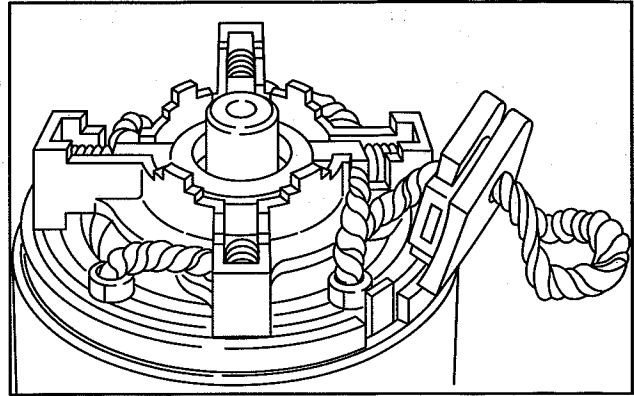

Fig. 74 – Installing Brushes

6. Install brush retainer plate.
7. Assemble rubber seal to starter housing, Fig. 75.
 - a. Be sure notch in rubber seal is inserted over tab on housing.

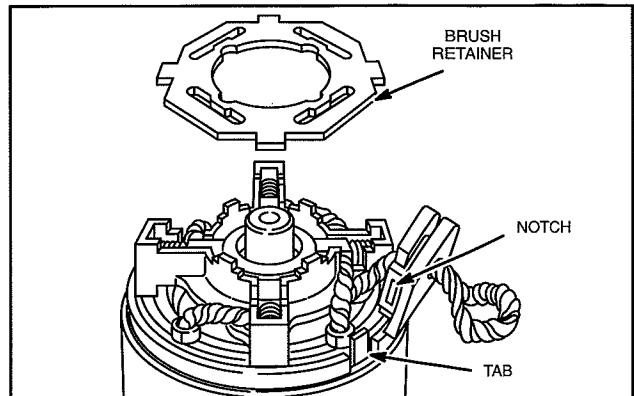

Fig. 75 – Assemble Rubber Seal

8. Install end cap, Fig. 76.
 - a. Torque thru bolts to 8.0 Nm (70 in. lbs.).
9. Install solenoid.
10. Install starter motor.
 - a. Torque screws to 40.0 Nm (30 ft. lbs.).

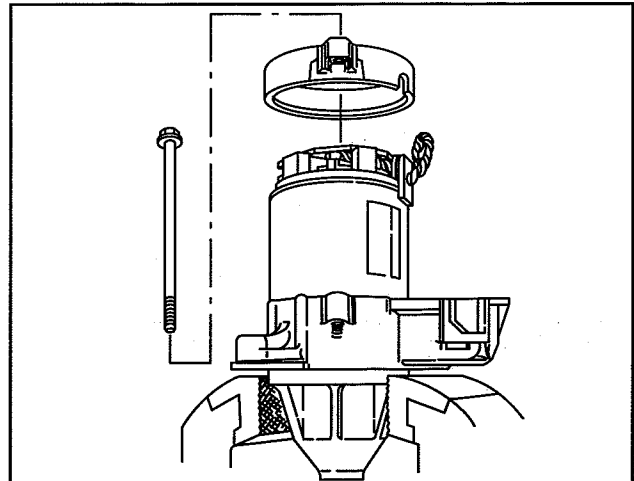
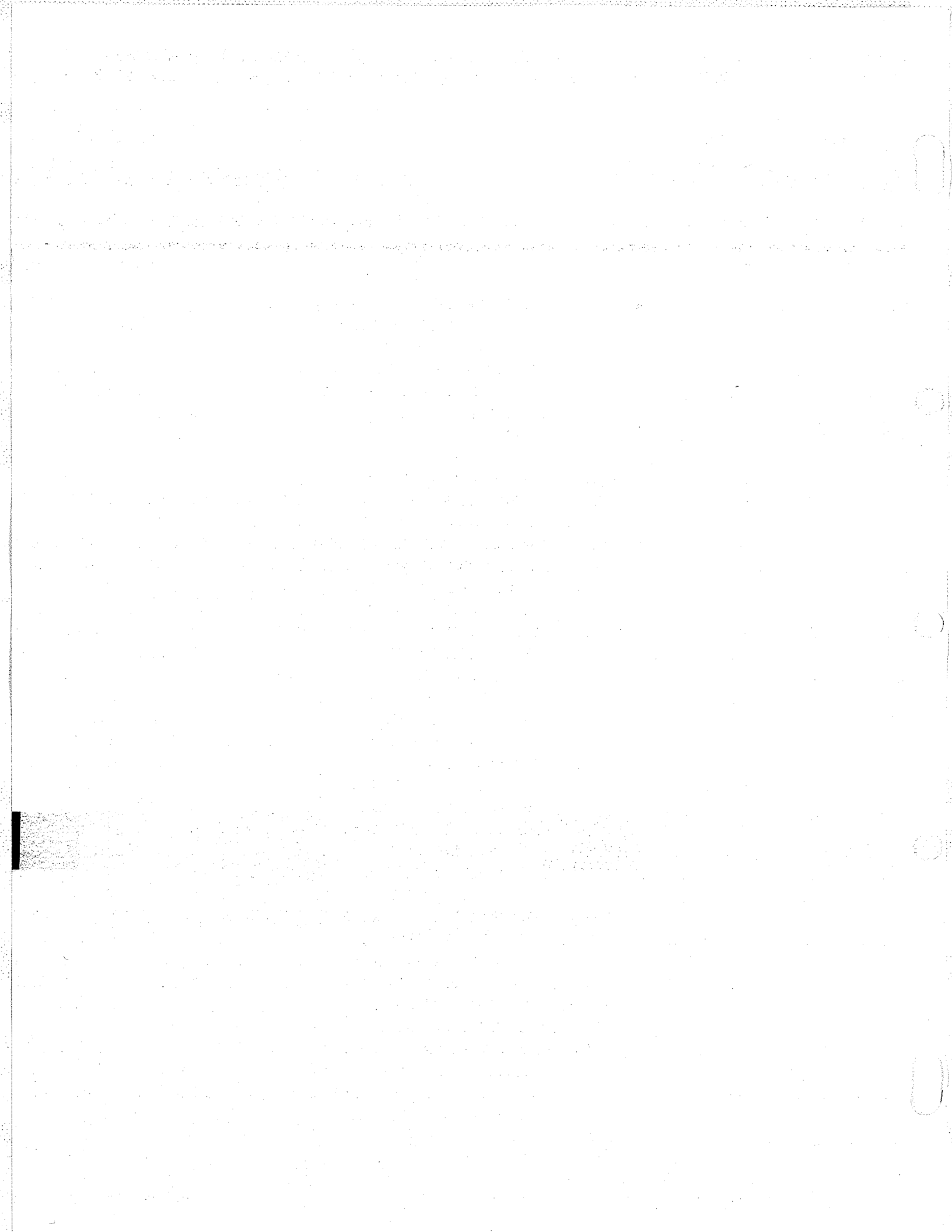

Fig. 76 – Installing End Cap



Section 12 Lubrication System

Section Contents

	Page
DESCRIPTION	2
CHANGE OIL	2
CHANGE OIL FILTER	2
CHECK OIL PRESSURE	3
DISASSEMBLE GEAR CASE	
Remove Oil Pump	4
ASSEMBLE GEAR CASE	
Install Oil Pump	6
ADJUST GOVERNOR	9

ROCKER ARM SHAFT

CAMSHAFT

CRANKSHAFT

OIL NOZZLE

OIL PUMP

OIL FILTER

OIL STRAINER

Recommended SAE Viscosity Grades

				30				
			10W-30 10W-40 10W-50					
		5W-30		*				
°F	-30	-10	10	32	50	70	90	110
°C	-34	-23	-12	0	10	21	32	43

STARTING TEMPERATURE RANGE ANTICIPATED BEFORE NEXT OIL CHANGE

* A synthetic 5W-30 oil may be used.

Use a high quality detergent oil classified "For Service SE" or higher. Use no special additives with recommended oils.

LUBRICATION SYSTEM

DESCRIPTION

Briggs & Stratton Daihatsu gasoline and diesel engines use a full pressure lubrication system with an oil filter. The gear driven oil pump draws oil from a screened oil pickup in the oil pan and pumps the oil through the oil filter.

The filtered oil flows through oil galleries in the cylinder block and is distributed to the main bearings, connecting rod bearings, camshaft bearings and rocker arm shaft.

A pressure relief valve limits the maximum oil pressure in the system.

CHANGE OIL

Change oil and filter after first 50 hours of operation. Thereafter, change oil and filter every 200 hours of operation. Change oil and filter more often if engine is operated in dusty or dirty conditions or if engine is operated under heavy loads or high ambient air temperatures.

Remove oil drain plug and drain oil while engine is still warm, Fig. 1. Check oil drain plug gasket and replace if necessary. Install and torque drain plug to 25.0 Nm (220 in. lbs.).

Remove oil fill cap and refill with oil of recommended grade and viscosity. See page 1.

Oil Capacity: 3.3 liters (3.5 quarts)

Fill to FULL mark on dipstick.

CHANGE OIL FILTER

Change oil filter every 200 hours of operation.

Before installing new filter, lightly oil filter gasket with fresh clean engine oil.

Note: Hand tighten 1/2 turn after gasket contacts mounting surface.

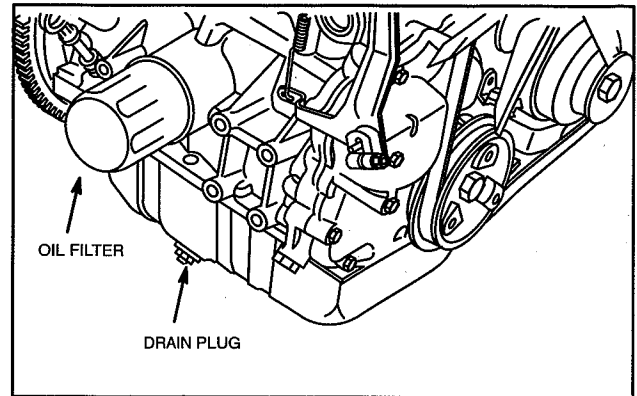

Fig. 1 – Oil Drain Plug

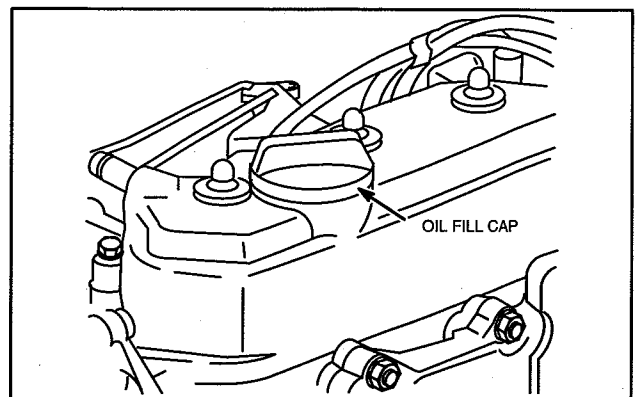

Fig. 2 – Oil Fill Cap

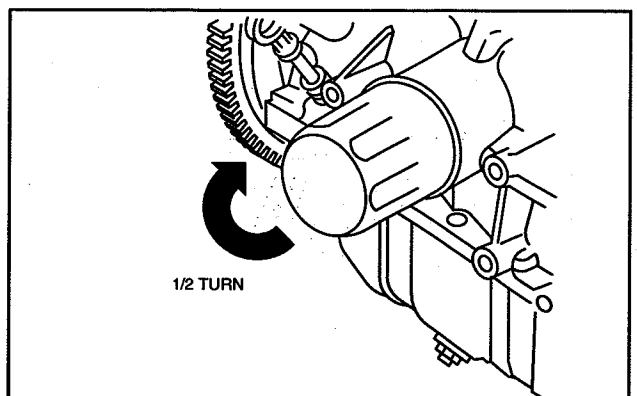

Fig. 3 – Replacing Oil Filter

CHECK OIL PRESSURE

1. Oil level should be between the LOW and FULL mark on dipstick. If oil level is low, check for leaks and add to FULL mark.

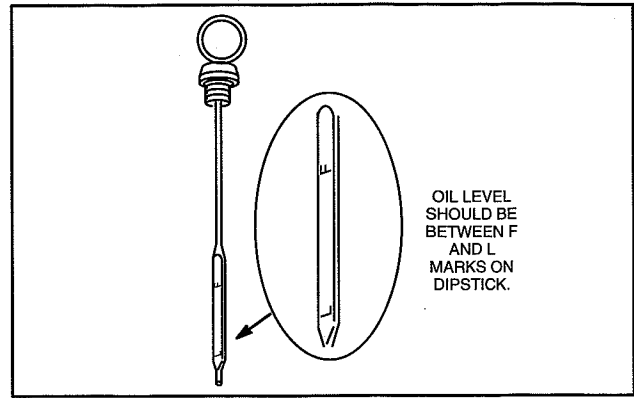

Fig. 4 – Oil Level

2. Remove oil pressure switch.
3. Install oil pressure gauge.
4. Start the engine and allow it to reach normal operating temperature.
5. Check oil pressure at 3000 RPM.

**Oil Pressure: 2.0 ~ 4.8 Bar
(28 ~ 70 psi)**

See charts below for troubleshooting guide.

Low Oil Pressure
Engine RPM Too Low
Wrong Viscosity or Diluted Oil
Low Oil Level
Broken Pressure Relief Spring
Missing Pressure Relief Plunger
Worn Bearings
Damaged Or Defective Oil Pump
High Oil Pressure
Wrong Viscosity Oil
Plugged Oil Galleries

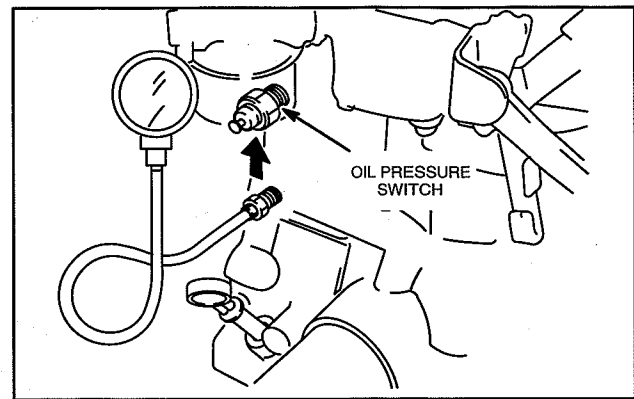
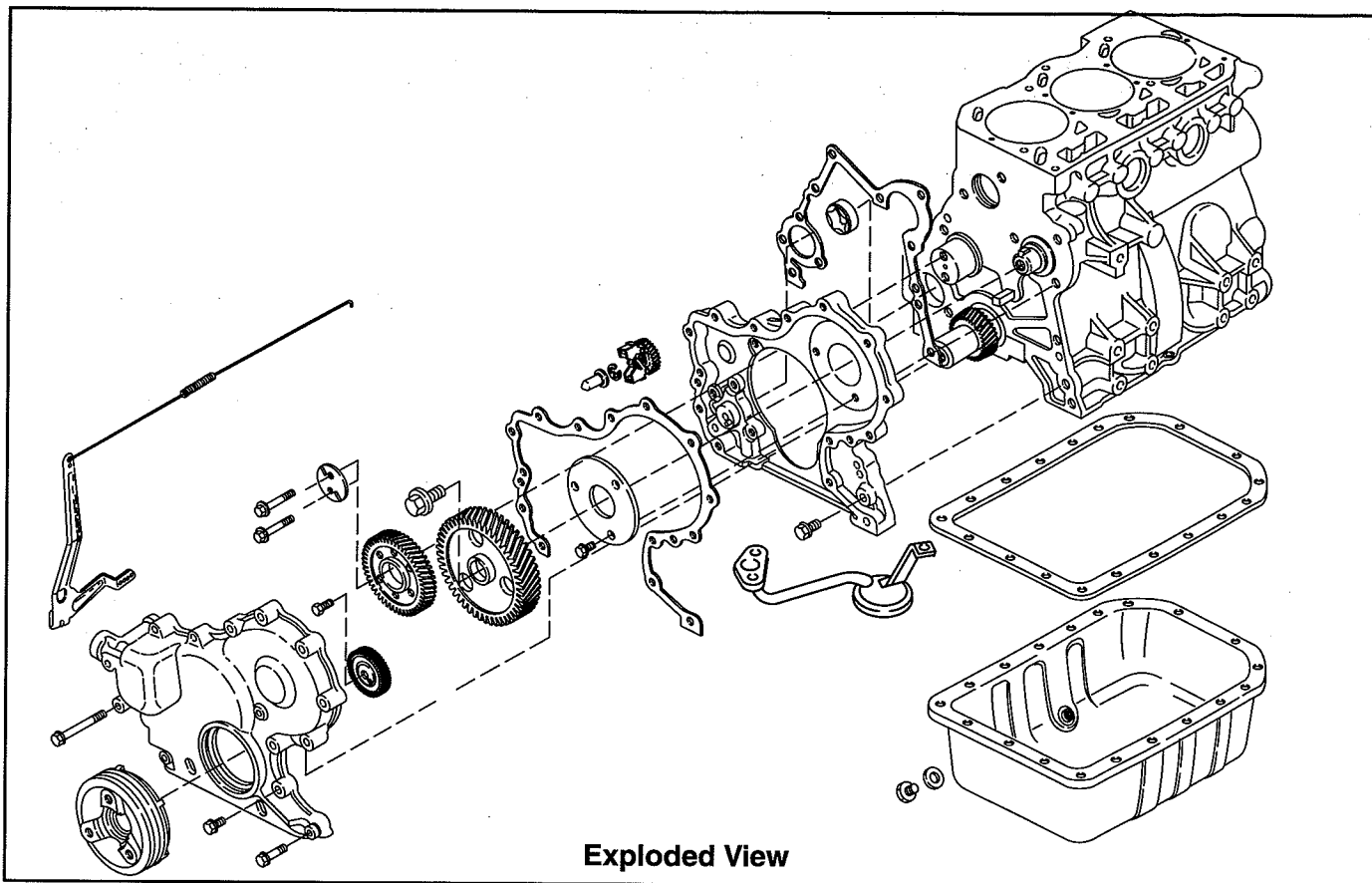

Fig. 5 – Checking Oil Pressure



DISASSEMBLE GEAR CASE

Remove Oil Pump

Remove spark plugs. Remove V belt and fan (if equipped). Drain oil from engine.

Note: Before removing governor spring, note hole position of governor spring in governor lever.

1. Remove the following parts.
 - a. Remove governor link spring, and governor link from carburetor.
 - b. Remove governor spring from governor lever.
 - c. Loosen nut and remove governor lever from governor shaft, Fig. 6.

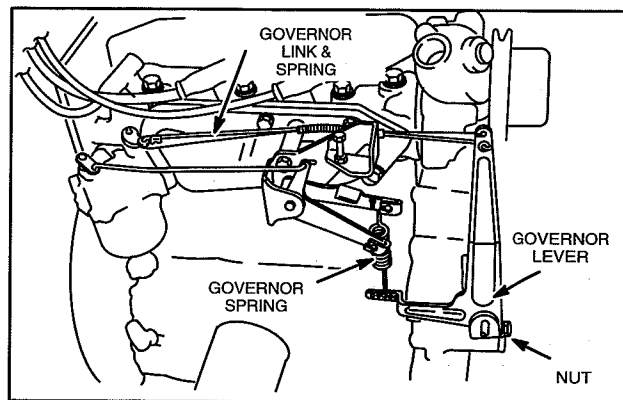

Fig. 6 – Remove Governor Lever

2. Remove oil pan screws and nuts.
 - a. Remove oil pan and discard gasket
 - b. Remove oil pick-up tube and strainer. Discard gasket, Fig. 7.

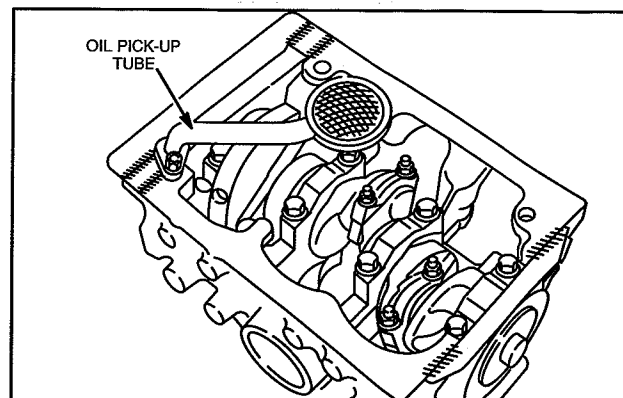

Fig. 7 – Removing Oil Pan

12

3. Install flywheel holder, Tool # 19418.
- LEAVE TOOL INSTALLED THROUGH STEP 8.
- a. Remove crankshaft pulley using Tool #19420, Fig. 8.

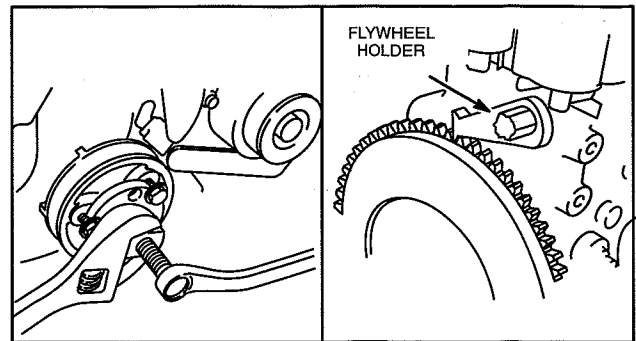

Fig. 8 – Removing Crankshaft Pulley

4. Remove trigger and wire. Remove timing gear cover, Fig. 9.
- a. Discard timing gear cover gasket.

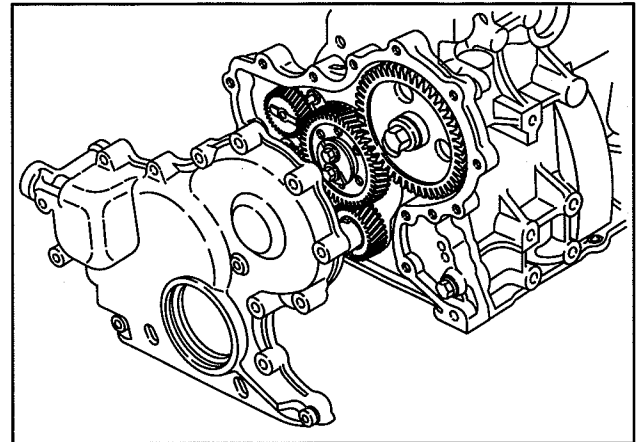

Fig. 9 – Removing Timing Gear Cover

5. Remove camshaft timing gear, Fig. 10.
 6. Remove idler gear.
- Note:** It is not necessary to remove idler gear shaft.
7. Check that oil pump turns freely by rotating gear by hand.
 8. Remove oil pump drive gear.
- Disengage flywheel holder.

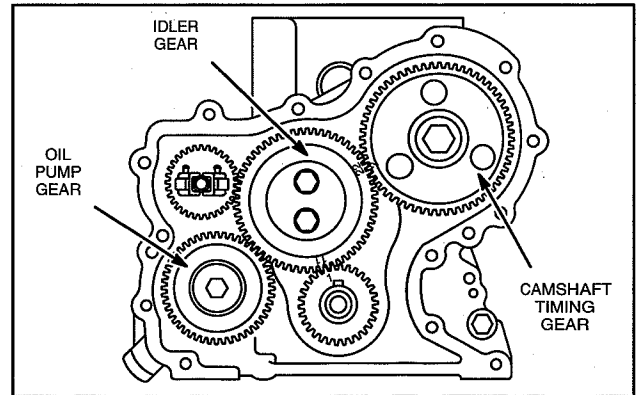

Fig. 10 – Removing Gears

9. Remove gear case, Fig. 11.
 - a. Remove 3 screws and camshaft retainer.
 - b. Remove remaining 5 screws.
 - c. Discard gasket.
10. Inspect rotors for wear or damage.
- Note:** If pump rotors are worn or damaged, replace the gear case.

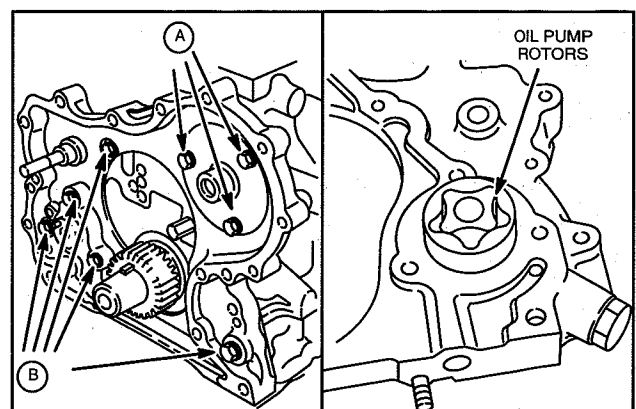

Fig. 11 – Removing Gear Case

LUBRICATION SYSTEM

11. Remove and check pressure relief valve assembly, Fig. 12.
 - a. Make sure plunger has no nicks or burrs.
 - b. Check pressure relief valve spring free length.

Spring free length:

35.5 mm ± 1.0 mm (1.400" ± .040")

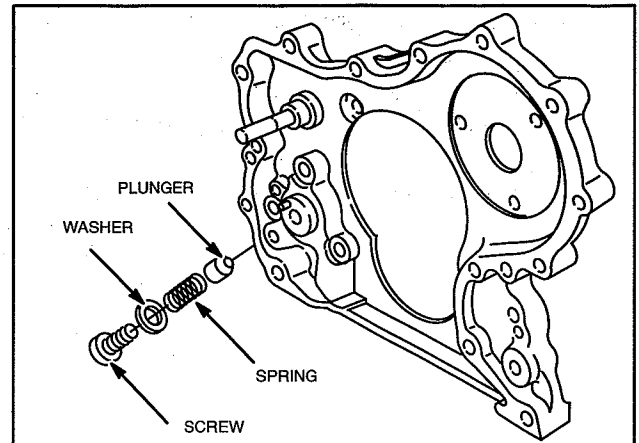

Fig. 12 – Checking Pressure Relief Valve

ASSEMBLE GEAR CASE Install Oil Pump

1. Lubricate oil pump rotor with engine oil and install in cylinder block, Fig. 13.
 - a. ID mark on rotor must face cylinder block.

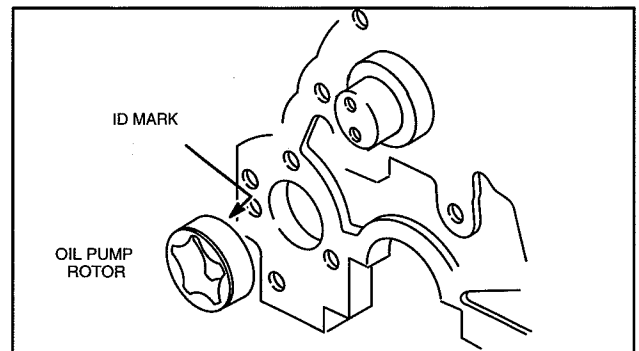

Fig. 13 – Installing Oil Pump Rotor

2. Install timing gear case with new gasket. Install camshaft retainer, Fig. 14.

Note: It may be necessary to rotate oil pump drive to engage oil pump rotors.

Note position, length and number of screws as shown.

- a. M6 x 28 mm (M6 x 1.1"): 4
- b. M6 x 18 mm (M6 x 0.7"): 3
- c. M6 x 16 mm (M6 x 0.6"): 1

Torque screws to 8.0 Nm (70 in. lbs.).

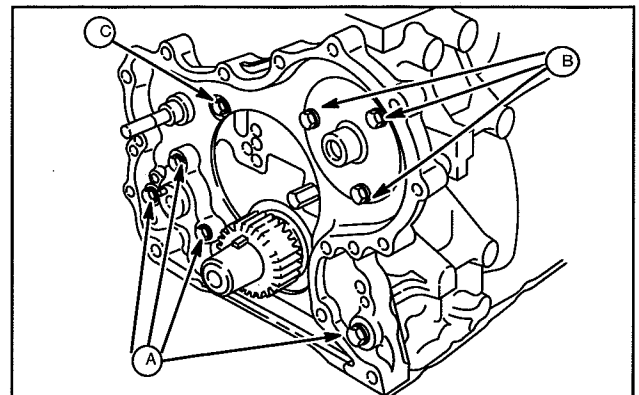

Fig. 14 – Installing Gear Case

3. Make sure crankshaft key is at 12 o'clock position as shown in Fig. 15.

Note: If idler gear shaft was removed, make sure that arrow faces up when reinstalling.

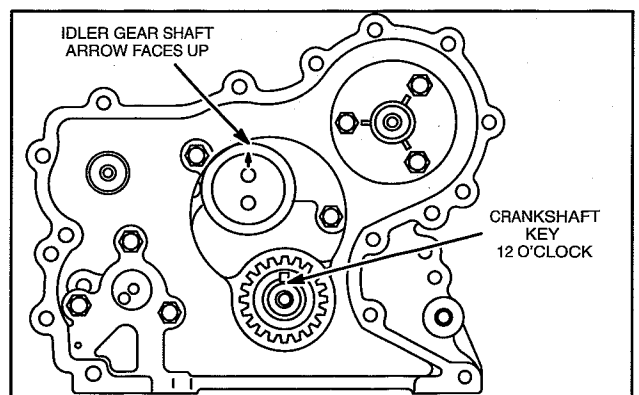

Fig. 15 – Crankshaft Position

Engine models 430000 and 580000 after date code 990111007 are equipped with right angle helical timing gears. Timing marks are identified by letters (A, AA, B, BB, etc.), instead of numbers. The timing procedure is the same.

4. With crankshaft key at 12 o'clock position, assemble idler gear so that timing mark 11 (AA) is aligned with timing mark 1 (A) on crankshaft gear, timing mark 22 (BB) is aligned with timing mark 2 (B) on camshaft gear as shown in Fig. 16.
 - a. Install oil pump gear.

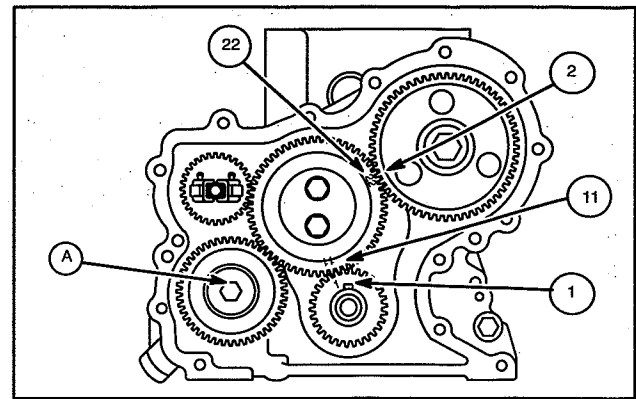

Fig. 16 – Aligning Timing Marks

Engage flywheel holder, Tool #19418.

5. Torque screws as shown, Fig. 17.
 - a. Camshaft gear: 41.0 Nm (30 ft. lbs.)
 - b. Idler gear: 25.0 Nm (220 in. lbs.)
 - c. Oil pump gear: 19.0 Nm (170 in. lbs.)

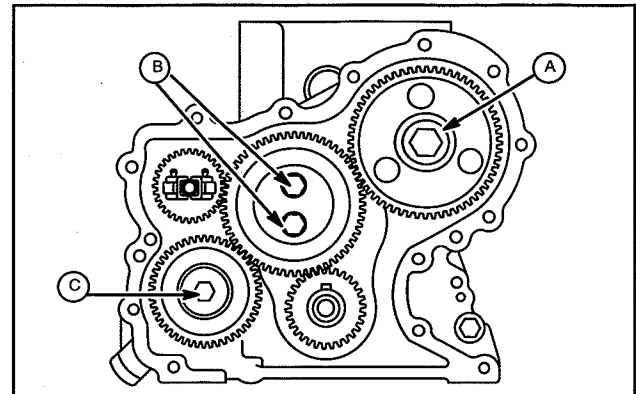

Fig. 17 – Torque Screws

6. Install timing gear cover with new gasket. Note position, length and number of screws as shown, Fig. 18.
 - a. M6 x 65 mm (M6 x 2.5"): 2
 - b. M6 x 55 mm (M6 x 2.1"): 3
 - c. M6 x 30 mm (M6 x 1.1"): 7
 - d. M6 Nuts: 2

Torque screws and nuts to 8.0 Nm (70 in. lbs.).

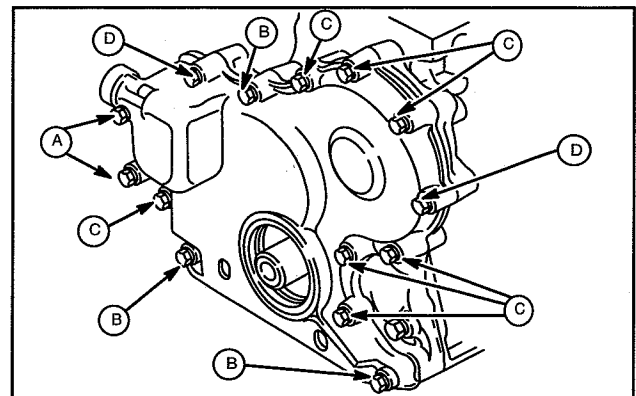

Fig. 18 – Installing Timing Gear Cover

7. Install crankshaft pulley with timing mark at 12 o'clock position (#1 cylinder), Fig. 19.

Note: Be sure alignment pin in crankshaft gear is seated in hole in pulley.

- a. Torque screw to 88.0 Nm (65 ft. lbs.).
- b. Remove flywheel holder.
- c. Install trigger assembly and wire.

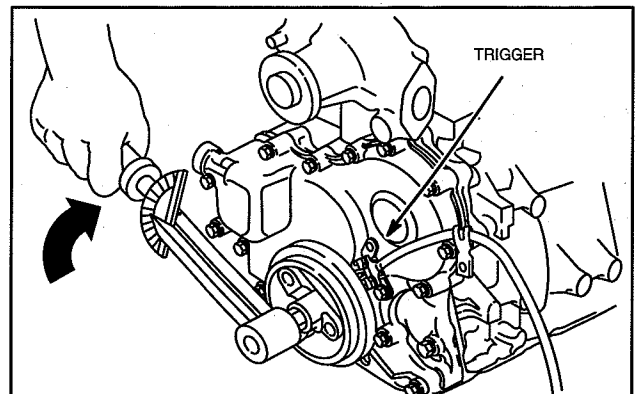

Fig. 19 – Installing Crankshaft Pulley

LUBRICATION SYSTEM

8. Install oil pick-up tube and strainer with new gasket. Torque to 8.0 Nm (70 in. lbs.).
 - a. Apply a small bead of Permatex® No. 2 or similar sealant to crankcase areas shown, Fig. 20.
 - b. Install oil pan with new gasket.
 - c. Torque screws and nuts to 8.0 Nm (70 in. lbs.).

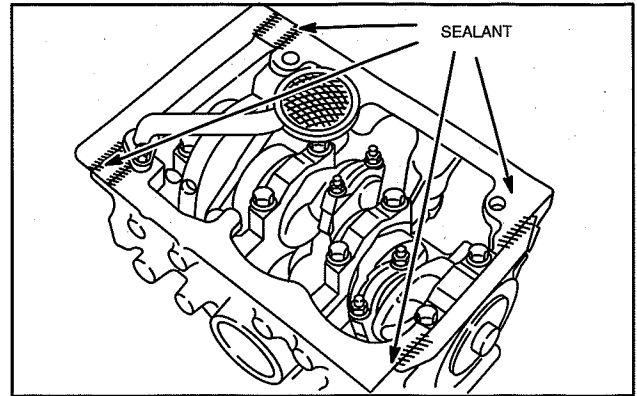

Fig. 20 – Installing Oil Pan

9. Install V belt and fan (if equipped).
 - a. **Belt adjustment:** 10.0-12.0 mm/10 kg (3/8-1/2 in/22 lb).
 - b. Install spark plugs.

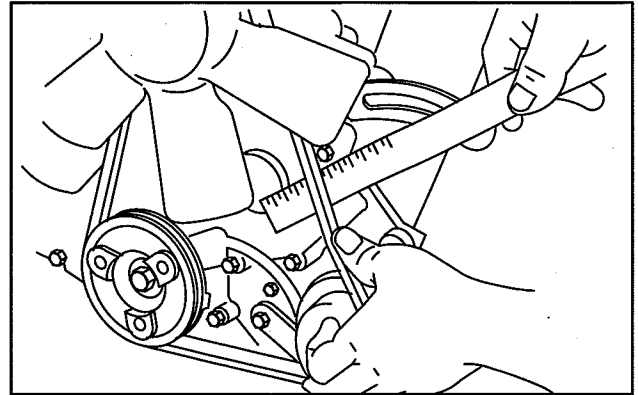

Fig. 21 – Adjusting V Belt

10. Install governor lever, Fig. 22. Do not tighten governor nut at this time.
 - a. Install governor link with spring.

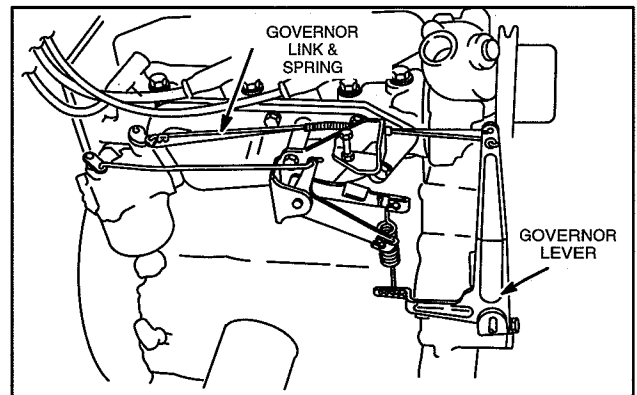

Fig. 22 – Installing Governor Lever

11. Insert governor spring into original hole in governor lever.

Note: Normal spring position is in center hole in governor lever, all models, Fig. 23.

Important: Governor spring must be installed in correct hole in governor control lever by engine model, Fig. 23.

- a. Model 430400 – Top Hole
- b. Model 580400 – Bottom Hole

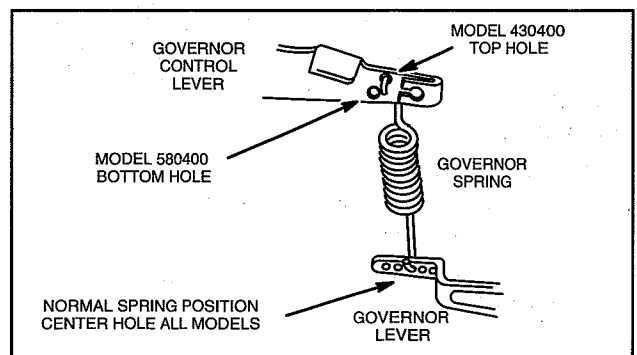

Fig. 23 – Governor Spring Position

ADJUST GOVERNOR

1. Move governor control lever up to end of travel and hold in this position (throttle wide open), Fig. 24.
 - a. Rotate governor shaft clockwise to end of travel.
 - b. Torque governor nut to 10.0 Nm (90 in. lbs.).

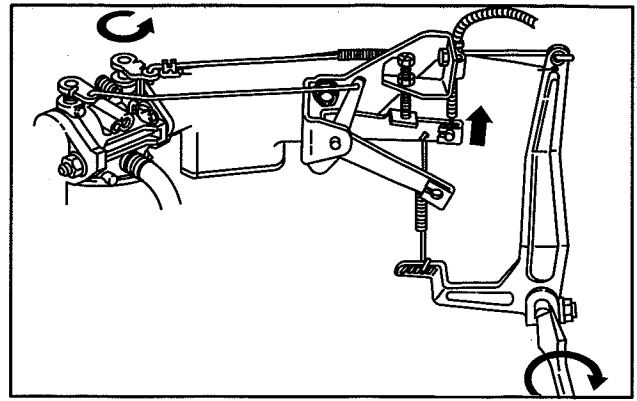
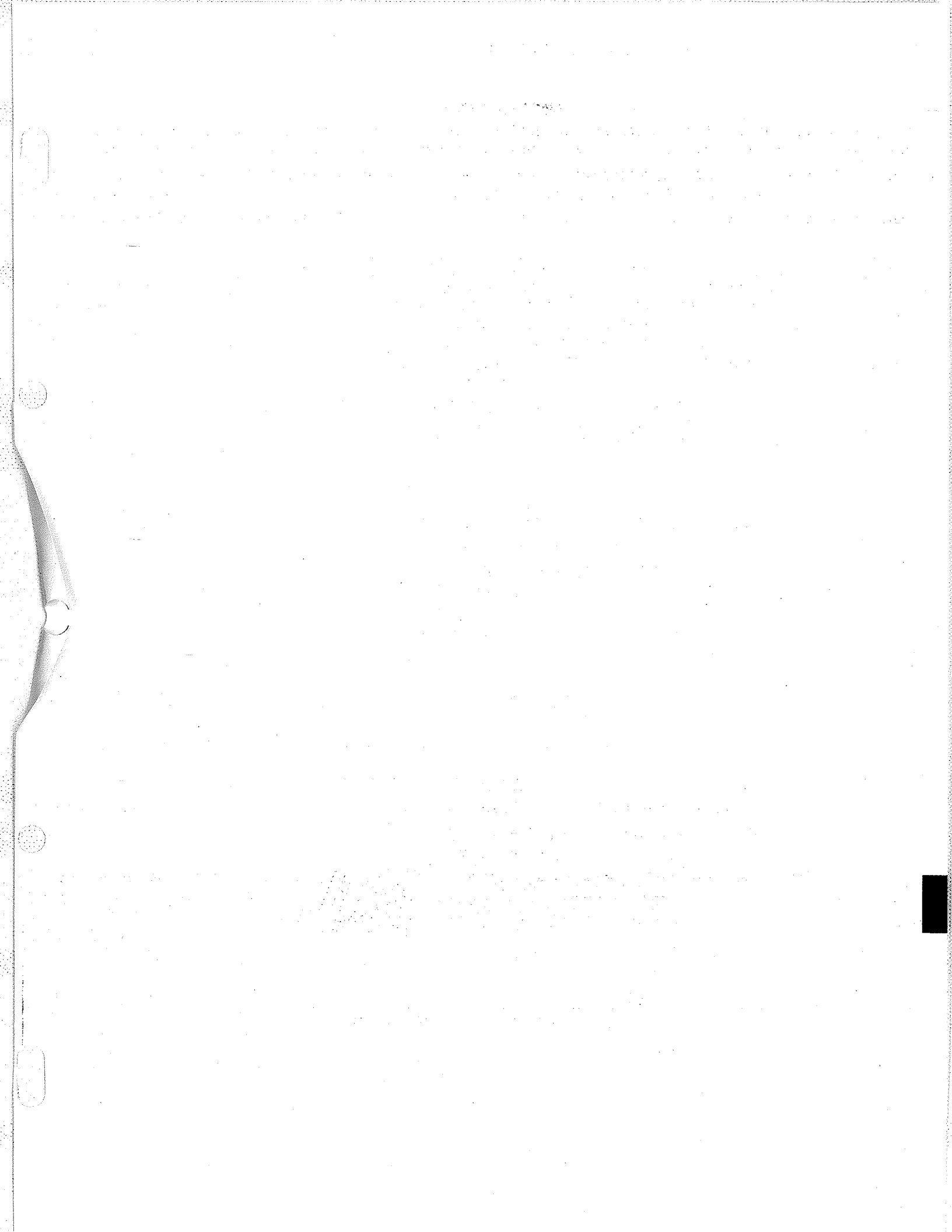
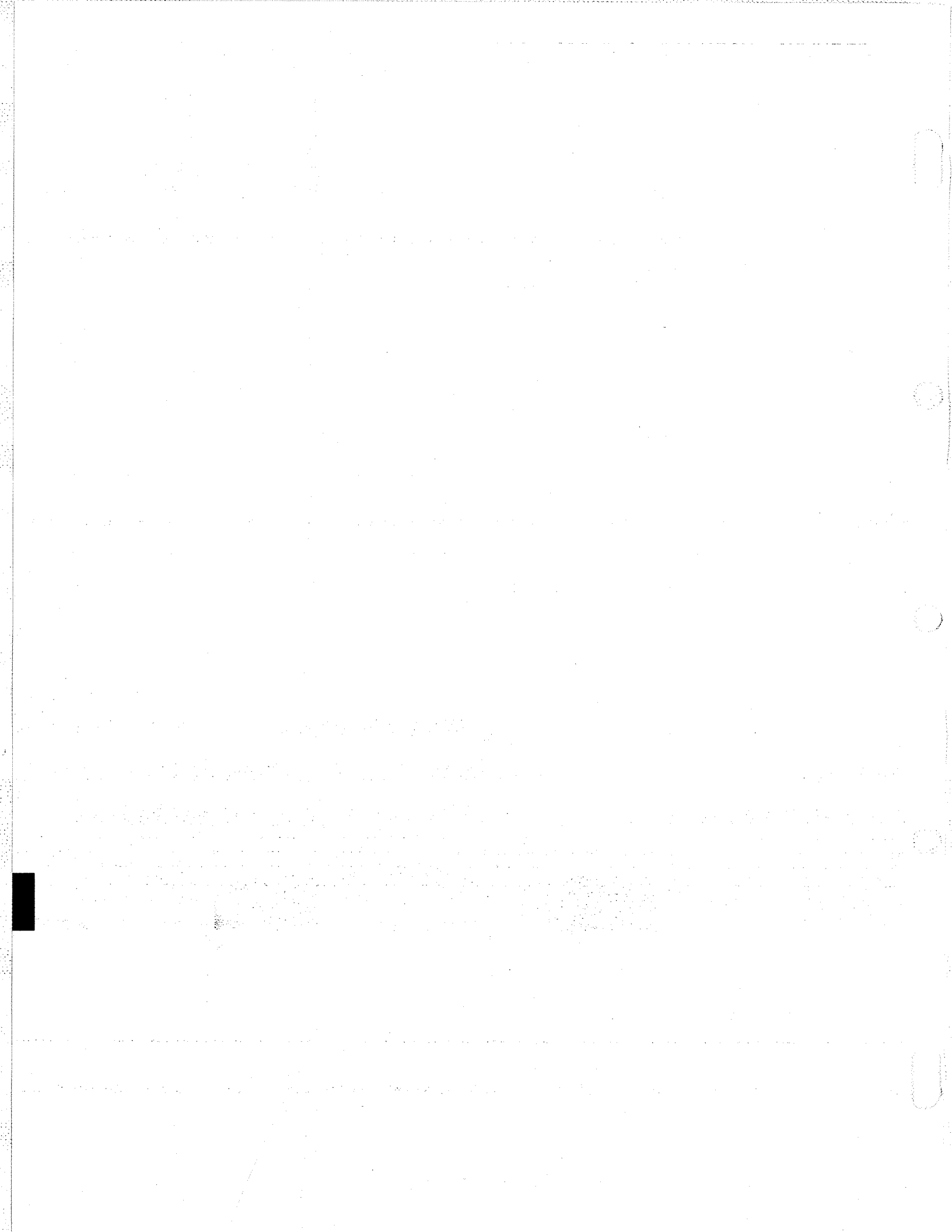

Fig. 24 – Adjusting Governor







Section 13 Cooling System

Section Contents

	Page
GENERAL INFORMATION	1
CHECKING COOLING SYSTEM	
Pressure Testing Cooling System	2
Testing Radiator Cap	2
CHANGING COOLANT	2
REMOVING THERMOSTAT	3
CHECKING THERMOSTAT	3
INSTALLING THERMOSTAT	3
INSPECTING WATER PUMP	4
REMOVING WATER PUMP	4
INSTALLING WATER PUMP	5

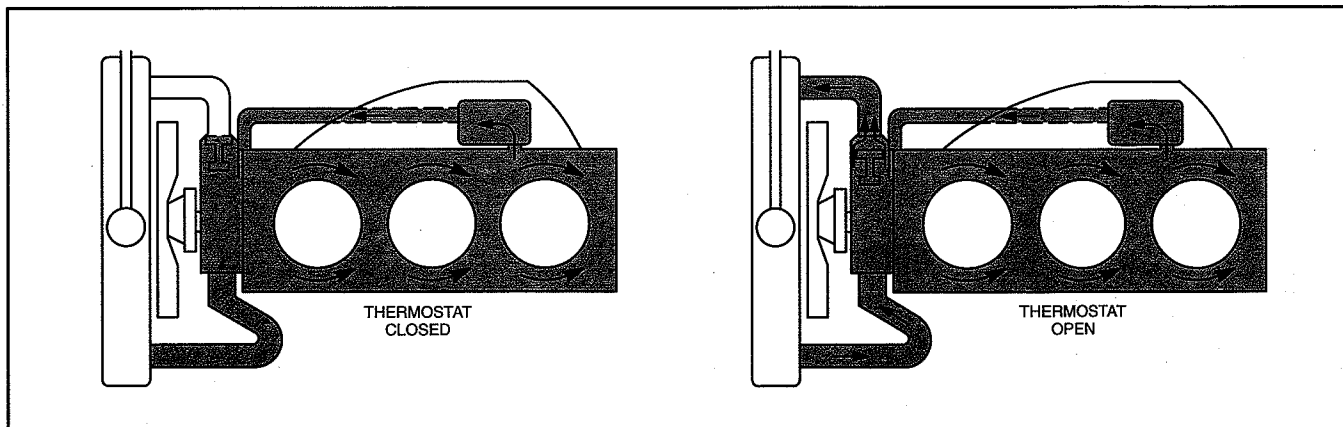

GENERAL INFORMATION

Briggs & Stratton Daihatsu gasoline and diesel engines use a pressurized, forced circulation cooling system.

The water pump circulates coolant through the cylinder block, cylinder head, intake manifold and radiator. The thermostat maintains optimum engine temperature.

The thermostat is equipped with a by-pass valve which permits coolant to re-circulate through the cylinder block, cylinder head and pre-heat the intake manifold. Pre-heating the intake manifold promotes fuel and air mixture efficiency when the engine is cold.

As the engine warms, the by-pass valve closes as the thermostat opens, permitting complete circulation through the radiator.

Always maintain a 50% solution of phosphate free antifreeze at all times for adequate heat dissipation, lubrication and protection from freezing.

COOLING SYSTEM

CHECKING COOLING SYSTEM



WARNING: the cooling system is pressurized. Do not remove the radiator cap while the engine is hot. To avoid scalding hot coolant or steam blowing out of the radiator, use extreme care when removing the radiator cap. If possible, wait for engine to cool. Wrap a thick rag around cap while removing. To release pressure, slowly turn cap counter clockwise to the first stop. When all pressure has been released, press down on cap and continue turning.

Pressure Testing Cooling System

1. Remove radiator cap and make sure coolant is at correct level.
 - a. Coolant level must be no more than 25 mm (1 in.) below bottom of filler neck.
2. Install cooling system pressure tester on radiator and pressurize system to 0.75 Bar (11 psi).
3. Check the following for any signs of leaking.

Note: System must maintain pressure during test.

- a. Hoses and connections (also check hoses for excessive bulging).
- b. Radiator.
- c. Water pump.
- d. Intake manifold and by-pass hose.
- e. Freeze plugs (cylinder block and cylinder head).

If system does not maintain pressure and no leaks are evident externally, check for an internal leak such as a blown head gasket, warped cylinder head or cylinder block.

Testing Radiator Cap

Make sure that rubber seal on radiator cap is not damaged or distorted. Rubber seals must be clean and free of debris to seal properly.

1. Install radiator cap on pressure tester and pressurize the cap.

Specification: 1.03 ~ 0.75 Bar (15 ~ 11 psi)

Replace cap if not within specification shown.

Note: Recommended pressure cap capacity is 0.9 Bar (13 psi).

CHANGING COOLANT

Coolant should be changed once a year. Change coolant with engine cold.

1. Remove radiator cap. Remove radiator drain plug and drain the system, Fig. 1.
2. Tighten drain plug.

Note: Follow state or federal laws regarding the proper procedure for disposing of anti-freeze.

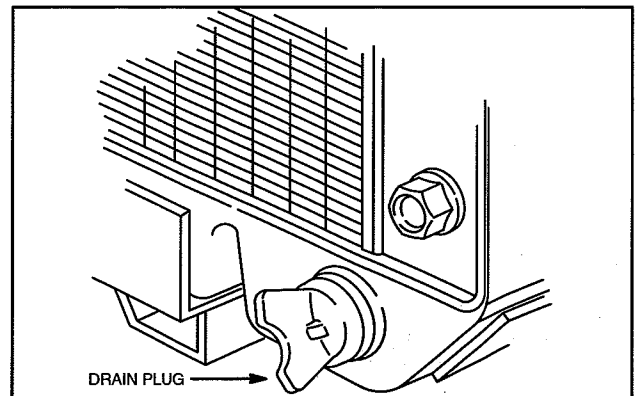

Fig. 1 – Draining Coolant

3. Fill radiator with 50% solution of phosphate free antifreeze.
4. Start and run engine until thermostat opens (when coolant level drops, thermostat is open).
5. Check coolant level in radiator and add coolant as required, Fig. 2.
6. Install radiator cap.

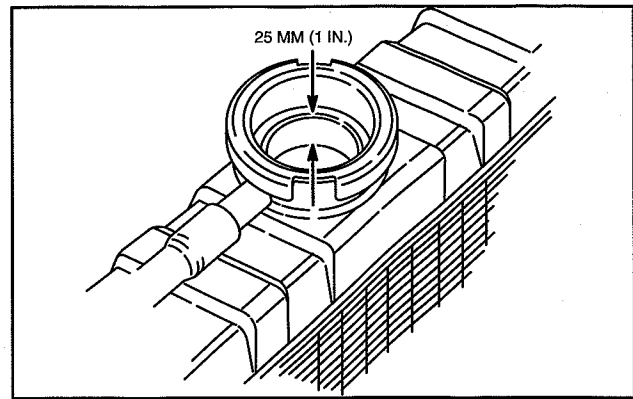

Fig. 2 – Adding Coolant

REMOVING THERMOSTAT – ENGINE COLD

1. Drain engine coolant.
2. Remove screws and coolant outlet housing.
3. Remove locating screw and thermostat, Fig. 3.
4. Remove all traces of gasket material.

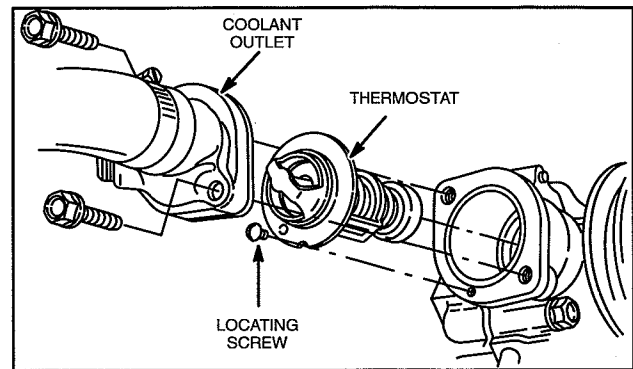

Fig. 3 – Removing Thermostat

CHECKING THERMOSTAT

A thermometer capable of reading 100° C (210° F) or more is required.

1. Check to make sure thermostat valve is fully closed.
2. Immerse thermostat in water and heat water gradually, Fig. 4.
3. Note temperature when thermostat starts to open.
 - a. **81~84° C (178 ~ 183° F)**
4. Note temperature when thermostat is fully open.
 - a. **95° C (203° F)**
5. Remove thermostat from water and allow to cool.
 - a. Thermostat should close fully.

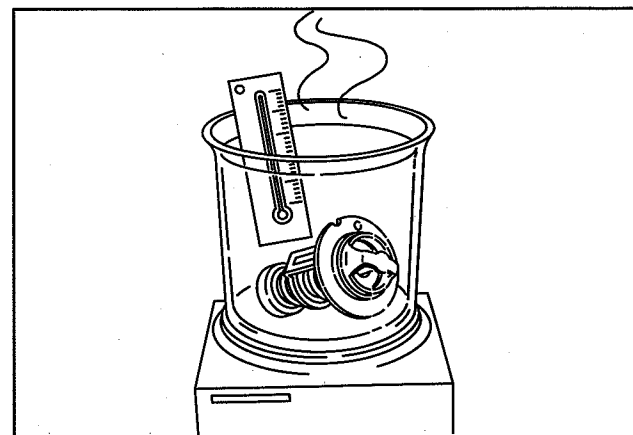

Fig. 4 – Checking Thermostat

INSTALLING THERMOSTAT

1. Insert thermostat in housing and install locating screw, Fig. 5.
2. Install coolant outlet housing with new gasket.
3. Torque screws to 6.8 Nm (60 in. lbs.).

Refill with coolant.

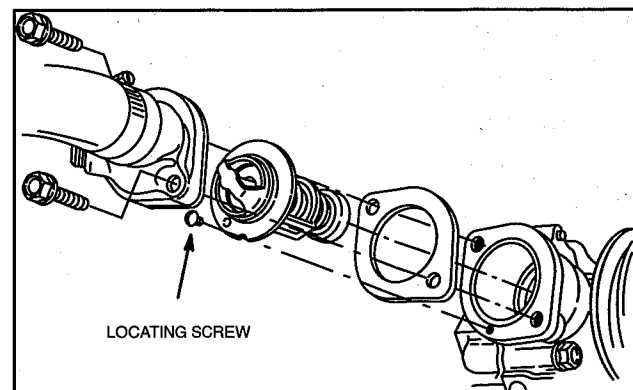

Fig. 5 – Installing Thermostat

COOLING SYSTEM

INSPECTING WATER PUMP

Inspect water pump for signs of leaking at vent holes, mounting surfaces and water pump pulley shaft, Fig. 6.

1. Remove V belt, alternator adjustment bracket, fan (if equipped) and water pump pulley.
 - a. Replace pulley if bent or damaged.

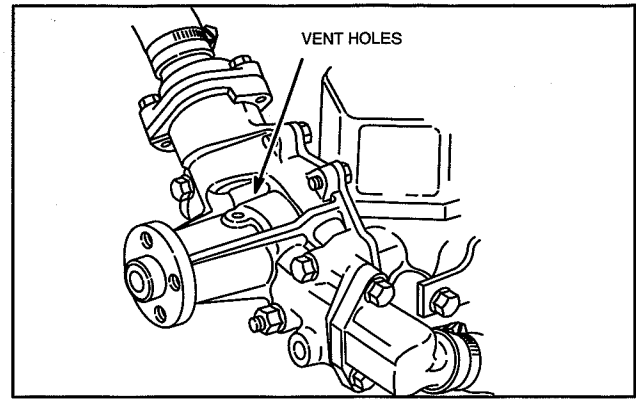

Fig. 6 – Inspecting Water Pump

2. Check water pump bearings by rotating pulley flange by hand, Fig. 7.
 - a. Make sure pulley rotates smoothly.

If water pump shows evidence of leaking or bearings are rough, replace the water pump.

Note: Most water pump and cooling system failures result from using straight water as a coolant. Without water pump lubricant and corrosion inhibitors, the water pump will fail prematurely.

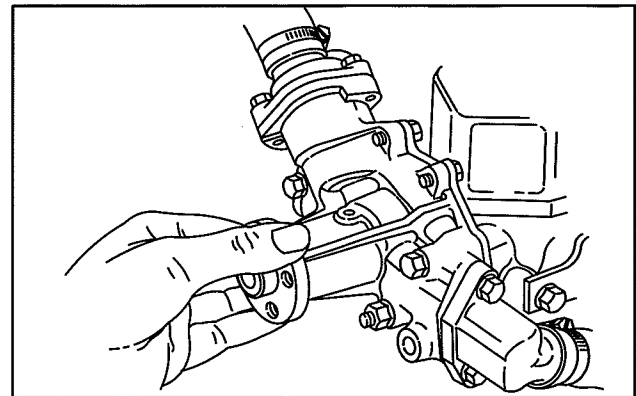

Fig. 7 – Checking Bearings

REMOVING WATER PUMP

Drain engine coolant.

1. Disconnect radiator hoses, Fig. 8.

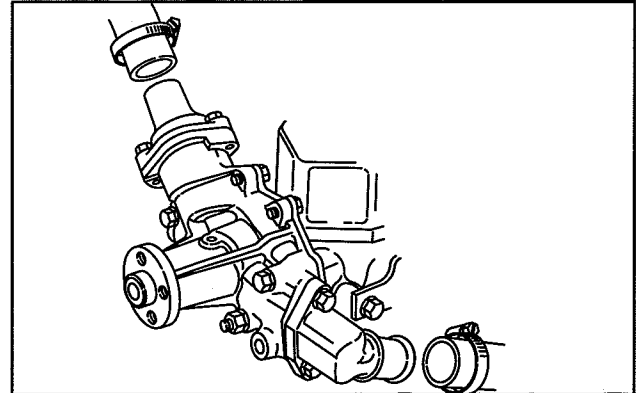

Fig. 8 – Remove Hoses

Remove the following parts, Fig. 9.

1. By-pass hose.
2. Temperature gauge wire (if equipped).
3. Coolant outlet.
4. Coolant inlet.
5. Water pump.

Clean all traces of gasket material from mounting surfaces and inspect mounting surfaces for damage.

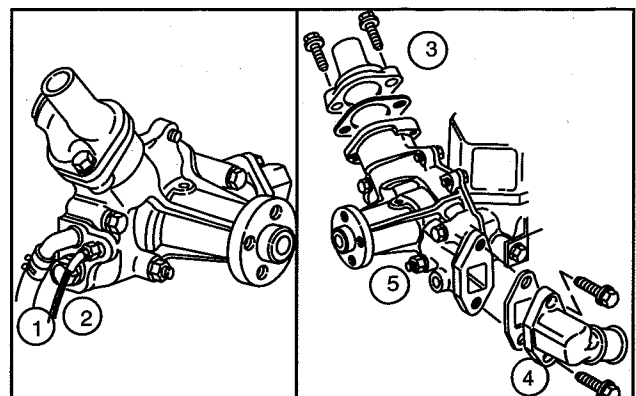

Fig. 9 – Removing Water Pump

INSTALLING WATER PUMP

1. Install water pump with new gasket, Fig. 10.
 - a. Torque screws and nuts to 19.0 Nm (180 in. lbs.).

After installing water pump make sure pump rotates smoothly.

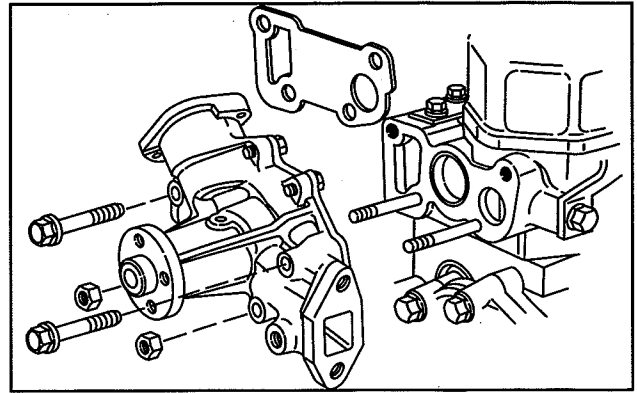

Fig. 10 – Installing Water Pump

2. Install coolant inlet with new gasket, Fig. 11.
 - a. Torque screws to 7.0 Nm (60 in. lbs.).
3. Install thermostat and coolant outlet with new gasket, Fig. 11.
 - a. Torque screws to 7.0 Nm (60 in. lbs.).
4. Install by-pass hose.
5. Install temperature gauge wire (if equipped).
6. Install radiator hoses.

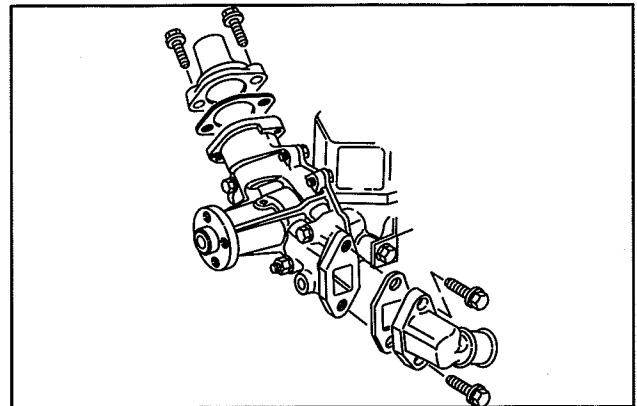

Fig. 11 – Installing Coolant Inlet And Outlet

7. Install fan (if equipped) and water pump pulley, Fig. 12.
 - a. Torque screws to 7.0 Nm (60 in. lbs.).

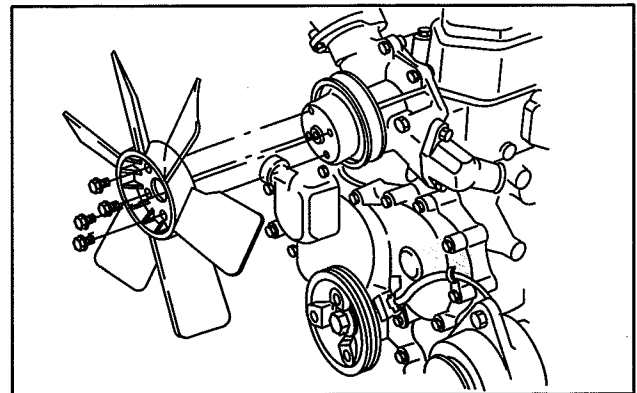

Fig. 12 – Installing Fan And Pulley

8. Install V belt, Fig. 13.
 - a. **Belt tension adjustment:** 10.0-12.0 mm/10 kg (3/8 – 1/2 in/22 lb).
9. Refill cooling system.

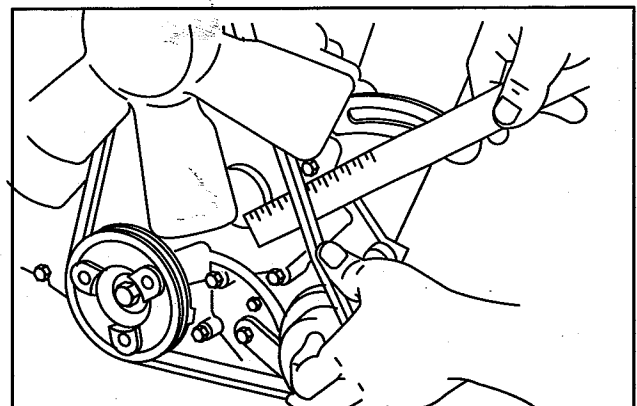
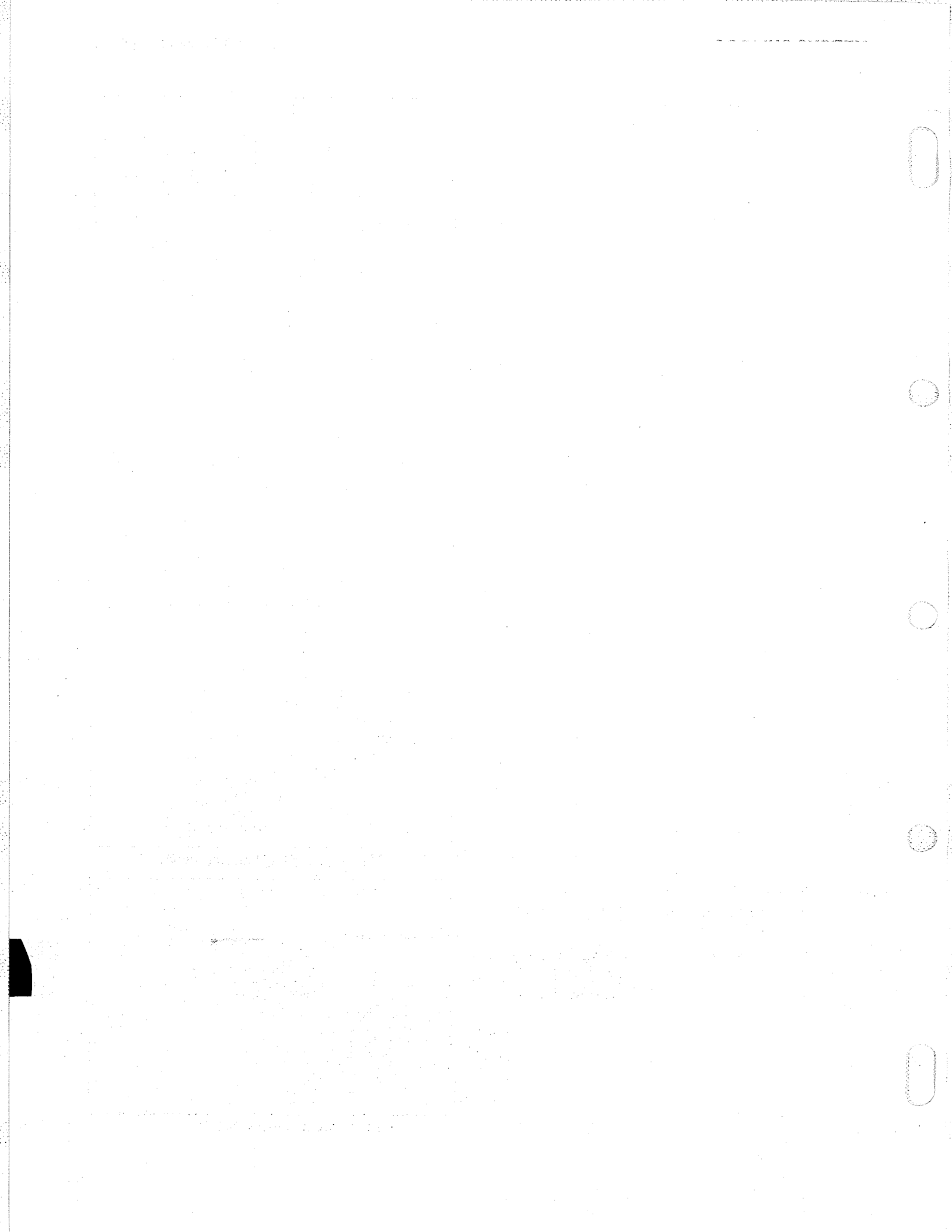
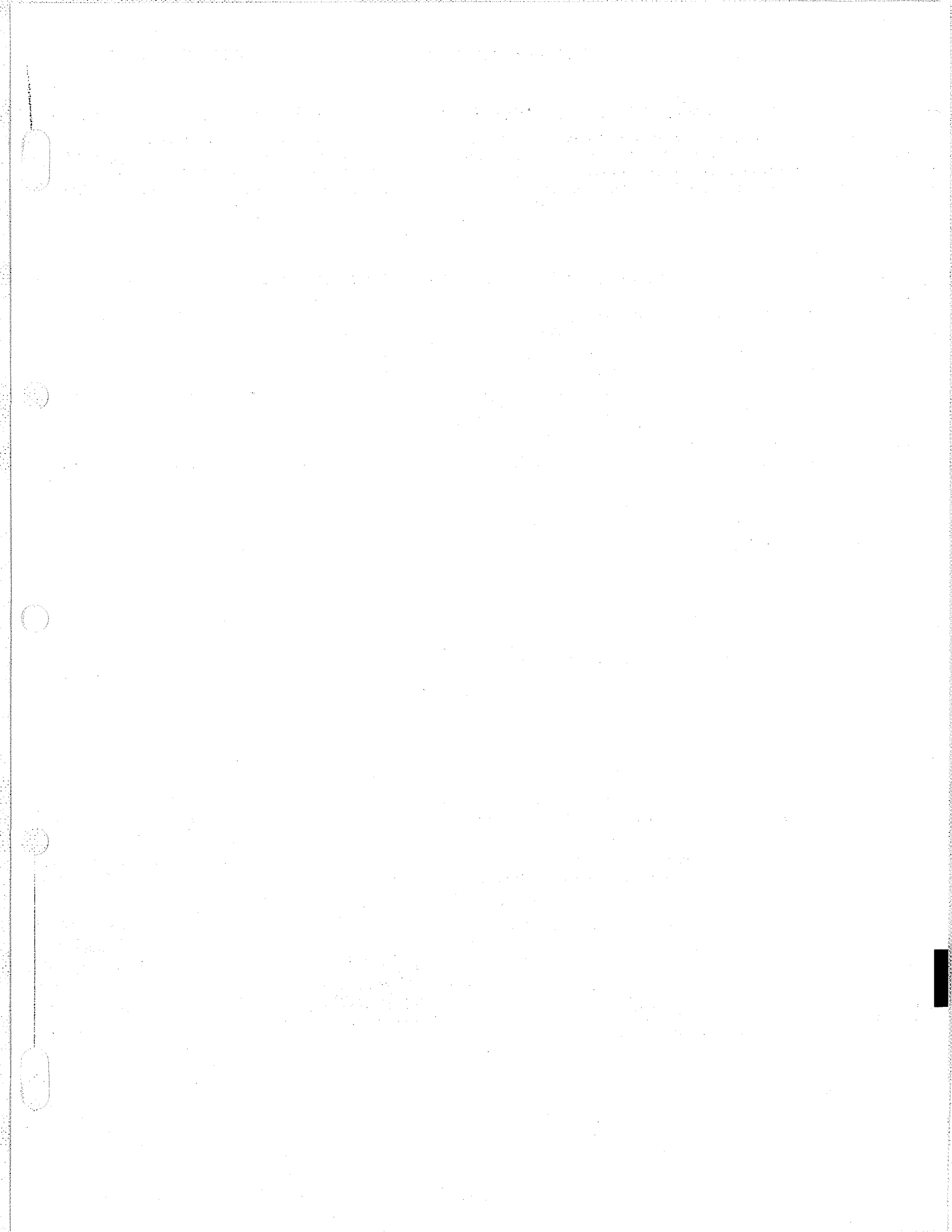
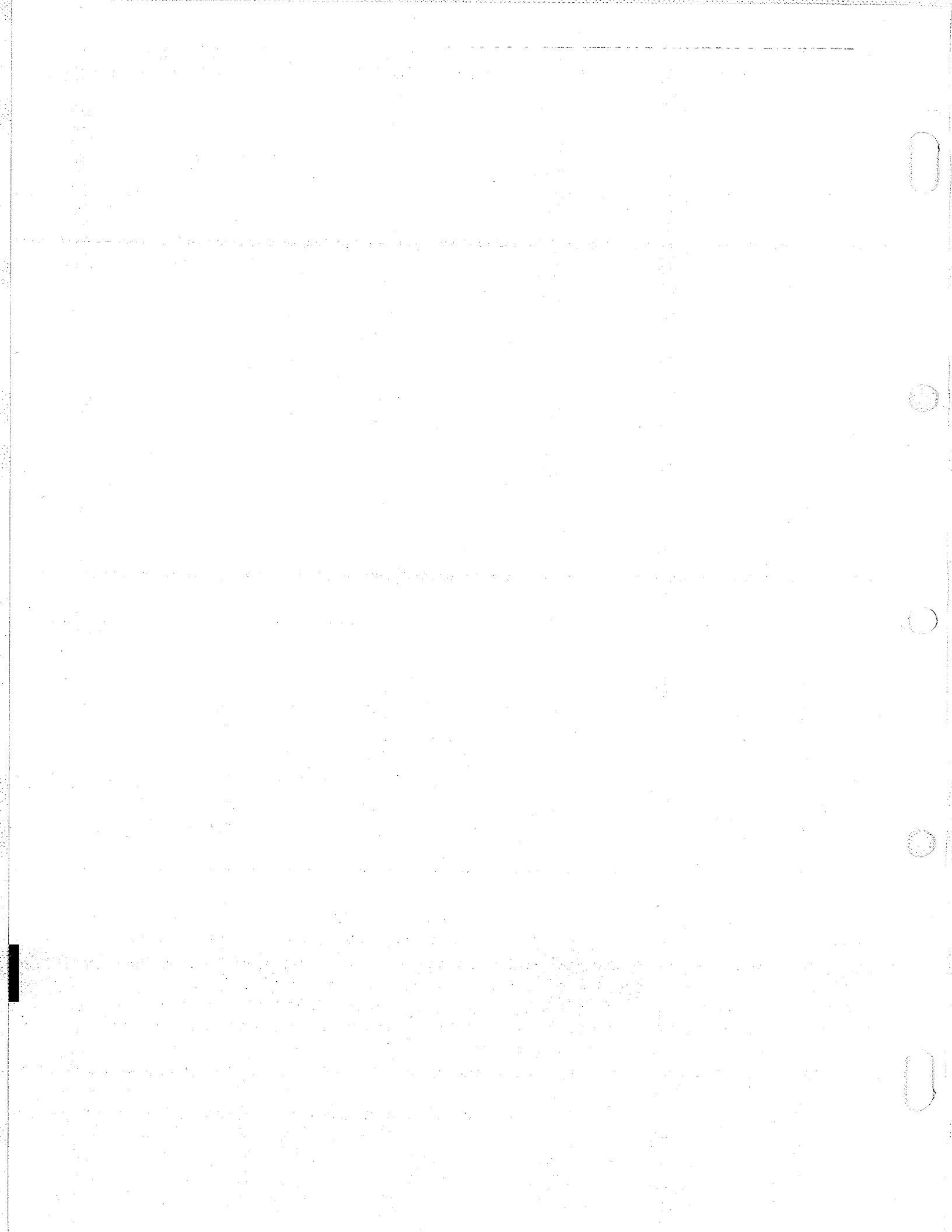

Fig. 13 – Install V Belt









**BRIGGS & STRATTON DAIHATSU 3 CYLINDER
LIQUID-COOLED GASOLINE ENGINE REPAIR MANUAL (MS-0750)**

Section 14 TOOLS

It is assumed that Briggs & Stratton Authorized Service Centers have common hand tools to repair engines.

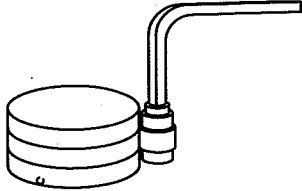
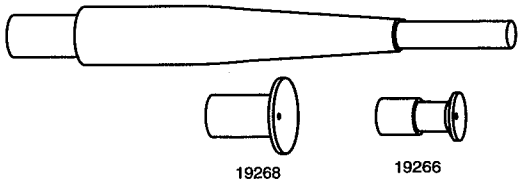
All Briggs & Stratton Authorized Service Centers are required to have Tool Kit #19300. Tools listed below are used on 3 cylinder water cooled engines and are part of Tool Kit #19300.

DESCRIPTION	TOOL NO.	USE
RING COMPRESSOR	19070	Install Piston and Rings 
VALVE LAPPER	19258	Lap Valve Face to Valve Seat Face 
VALVE GUIDE LUBRICANT (Anti-Seize Compound)	93963	Lubricate valve stems and valve guides, spark plug threads, muffler bolts and cylinder head bolts 
CLOVER® VALVE LAPPING COMPOUND	94150	Lapping Valves 

TOOLS

BRIGGS & STRATTON REPAIR TOOLS (Cont'd.)

The following special tools are required for Briggs & Stratton Authorized Service Centers, in addition to Tool Kit #19300.

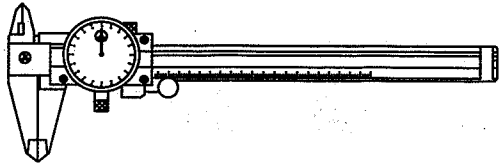
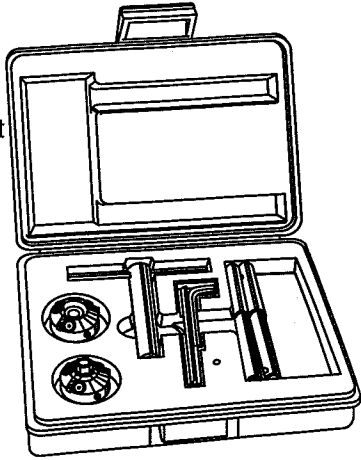
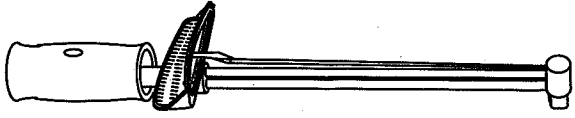
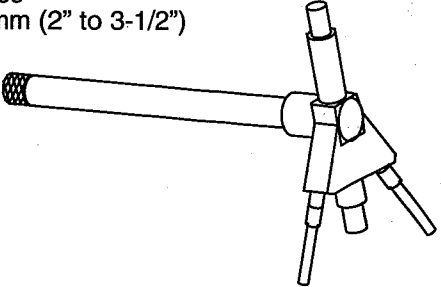
DESCRIPTION	TOOL NO.	USE
DIAL CALIPER	19199	Measure Engine Wear Range 0" to 6" Accurate to .001" 
VALVE SEAT CUTTER KIT	19446	Recondition 30° and 45° Valve Seats Includes 15° cutter for top cutting 30° seats Includes 6.0 and 6.02 mm pilots For replacement cutter blade set order part# 19302 Always replace blades as a set 
TORQUE WRENCH	19393	Range: 0 to 345 Kgcm (0 to 300 In. Lbs.) 
TELESCOPING GAUGE	19404	Measure Cylinder Bores Range: 50 mm to 89 mm (2" to 3-1/2") 

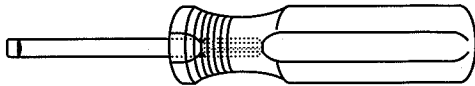
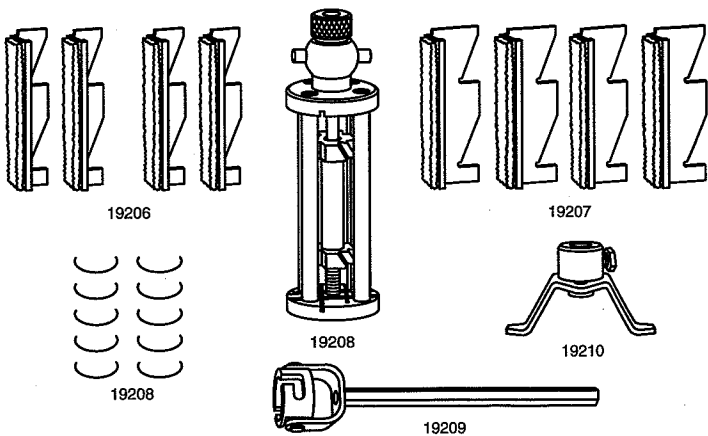
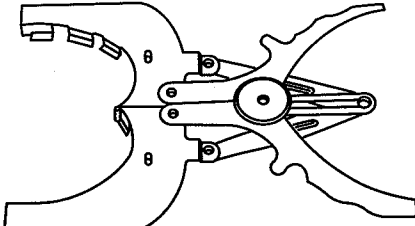
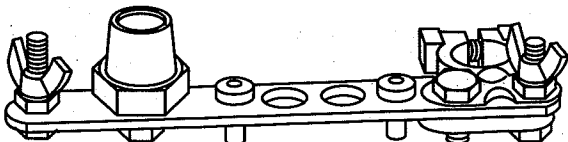

BRIGGS & STRATTON REPAIR TOOLS (Cont'd.)

The following tools are recommended for complete engine repair.

DESCRIPTION	TOOL NO.	USE
SCREWDRIVER	19061	Remove carburetor jets 
HONE SET	19205	Resize Cylinder Bores to .25 mm (.010"), .51 mm (.020"), .76 mm (.030") Oversize 
RING EXPANDER	19340	Remove and Install Piston Rings 
DC SHUNT	19468	Use with Digital Multimeter 19464 for measuring current draw of 12 volt electric starter motor and out put of charging system 

TOOLS

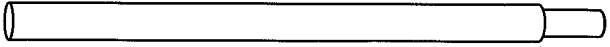
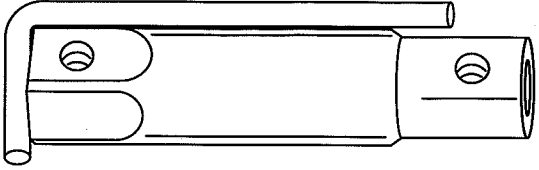
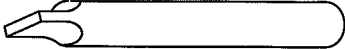
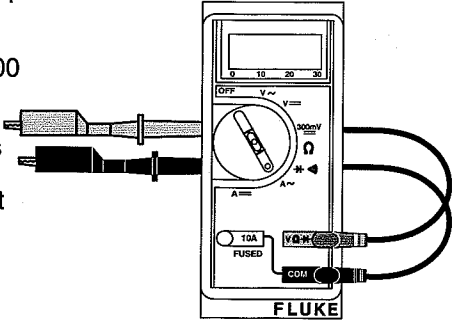
BRIGGS & STRATTON REPAIR TOOLS (Cont'd.)

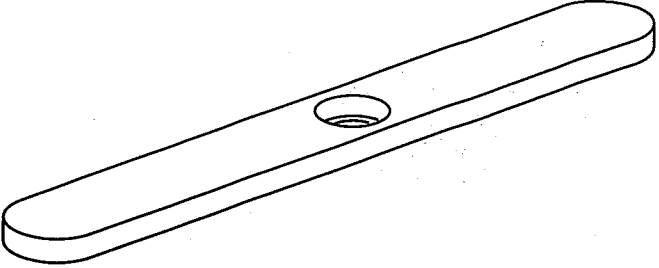
DESCRIPTION	TOOL NO.	USE
BUSHING DRIVER	19367	Remove Valve Guides 
SPARK PLUG WRENCH	19374	Remove 5/8" and 13/16" Spark Plugs 
PLUG GAUGE	19382	Check Valve Guides for Wear 
DIGITAL MULTIMETER	19464	Measure electrical equipment AC Volts, 0 to 750 DC Volts, 0 to 1000 Ohms, 0 to 320,000,000 AC & DC Amps, 0 to 10 Continuous 0 to 20 for 30 Seconds Audible Diode Test Audible Continuity Test Auto Ranging 
REPLACEMENT FUSE	19449	
VALVE GUIDE DRIVER	19416	For Installing Valve Guides 
VALVE SPRING COMPRESSOR	19417	For Removing And Installing Valve Springs 

BRIGGS & STRATTON REPAIR TOOLS (Cont'd.)

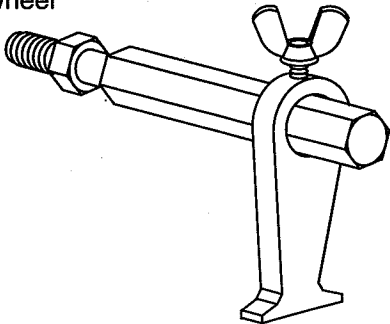
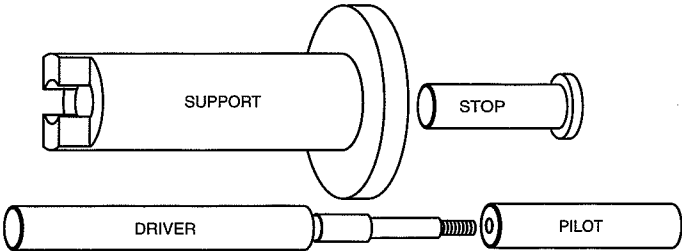
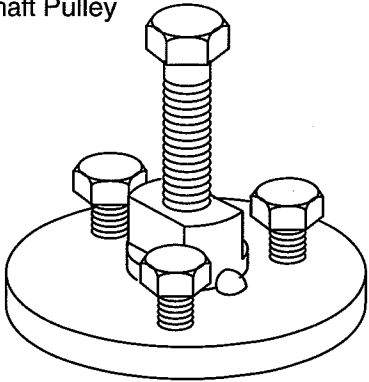
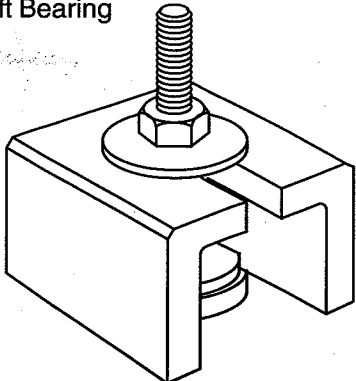
DESCRIPTION	PART NO.	USE
FLYWHEEL HOLDER	19418	For Holding Flywheel 
PISTON PIN FIXTURE	19419	For Removing and Installing Piston Pin 
CRANKSHAFT PULLEY PULLER	19420	For Removing Crankshaft Pulley 
CAMSHAFT BEARING PULLER	19421	For Removing Camshaft Bearing 

TOOLS

BRIGGS & STRATTON REPAIR TOOLS (Cont'd.)

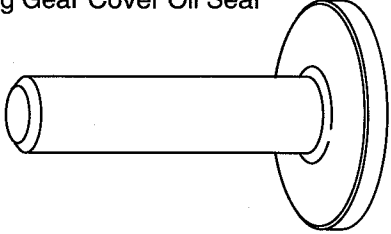
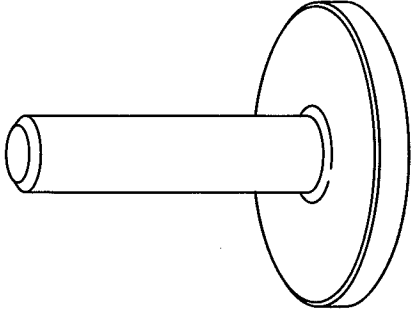
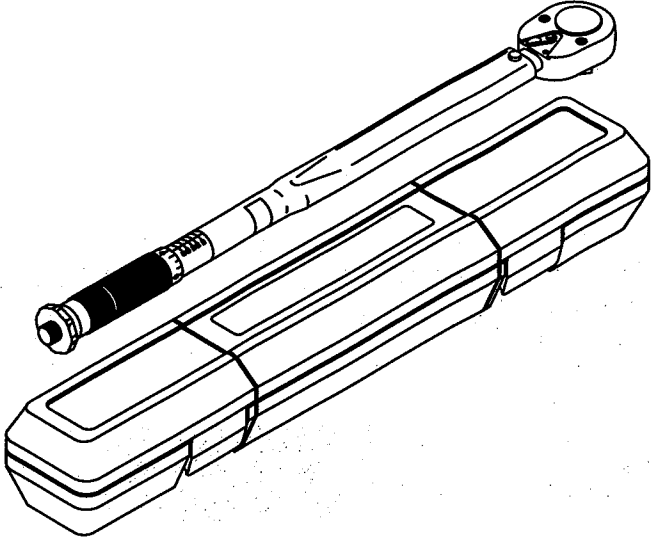
DESCRIPTION	PART NO.	USE
CAMSHAFT BEARING DRIVER	19422	For Installing Camshaft Bearing 
SEAL DRIVER	19423	For Installing Timing Gear Cover Oil Seal 
SEAL DRIVER	19424	For Installing Rear Oil Seal 
TORQUE WRENCH	19434	Adjustable Click Type With Ratchet 0 to 203 Nm (0 to 150 Ft. Lbs.) 

BRIGGS & STRATTON REPAIR TOOLS (Cont'd.)

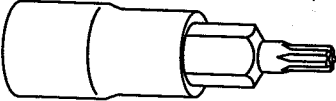
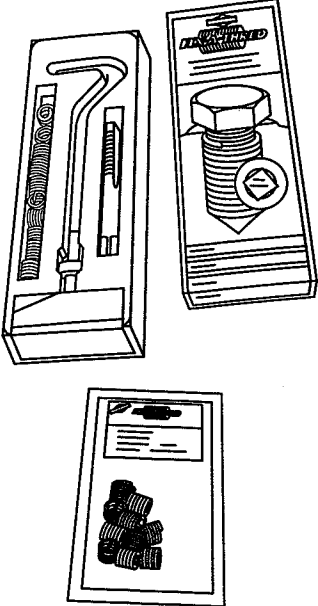
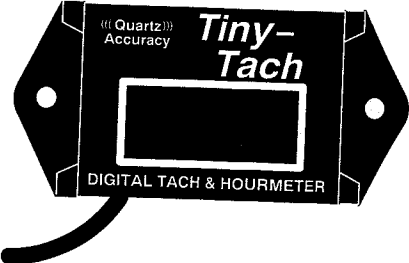
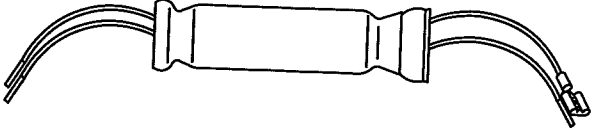
DESCRIPTION	PART NO.	USE
TORX® DRIVER	19445	For Installing Tamper Proof Governor Paddle Screws 
FIX-A-THREAD KITS THREAD INSERT REFILLS	100010 100011 100012 100013 100017 100018 100019 100021	For Repairing Damaged and Stripped Threads Thread Repair Kit M5x.8 Thread Repair Kit M6x1 Thread Repair Kit M8x1.25 Thread Repair Kit 14 mm Spark Plug – 3/4” M5x.8 Refill M6x1 Refill M8x1.25 Refill 14 mm Spark Plug Refill – 3/4” 
DIGITAL TACHOMETER & HOURMETER	19389	Meter displays RPM while engine is running. When engine is stopped, meter displays elapsed time. 
TACHOMETER ADAPTOR	19456	When attached to ignition module, permits use of Digital Tachometer, 19389 on Vanguard™ 3 cylinder liquid cooled gasoline engines. 

The first part of the document discusses the importance of maintaining accurate records of all transactions. It emphasizes that every entry should be supported by a valid receipt or invoice. This ensures transparency and allows for easy verification of the data.

Furthermore, it is noted that regular audits are essential to identify any discrepancies or errors early on. This proactive approach helps in maintaining the integrity of the financial statements and prevents any potential issues from escalating.

In addition, the document highlights the need for clear communication between all parties involved. Regular meetings and reports should be conducted to keep everyone informed about the current status and any changes that may occur. This collaborative effort is key to the success of the project.

The second section focuses on the implementation of the proposed plan. It details the specific steps that need to be taken, including the allocation of resources and the assignment of responsibilities. Each team member should have a clear understanding of their role and the expected outcomes.

It is also important to establish a timeline with realistic milestones. This will help in tracking progress and ensuring that the project stays on schedule. Any delays should be addressed immediately to avoid any negative impact on the overall objectives.

Finally, the document concludes by stating that the success of the project depends on the commitment and dedication of the entire team. By working together and following the guidelines outlined here, we can achieve our goals and deliver high-quality results.

The following table provides a summary of the key components and their respective responsibilities. This will serve as a reference point throughout the project.

Component	Responsible Party	Start Date	End Date
Financial Reporting	John Doe	2023-01-15	2023-03-31
Resource Allocation	Jane Smith	2023-02-01	2023-04-15
Communication & Reporting	Mike Johnson	2023-01-20	Ongoing
Quality Assurance	Sarah Lee	2023-03-01	2023-05-31

The third part of the document addresses the potential risks and challenges that may arise during the project. It provides strategies to mitigate these risks and ensure that the project remains on track.

One of the primary risks is the possibility of budget overruns. To avoid this, it is recommended to maintain a strict budget and regularly review the financial status. Any unexpected costs should be identified and addressed promptly.

Another challenge is the potential for communication breakdowns. To prevent this, it is crucial to establish clear channels of communication and hold regular check-ins. Encouraging open dialogue and active participation from all team members will help in resolving any issues quickly.

In conclusion, the document reiterates the importance of a structured and collaborative approach. By adhering to the guidelines and maintaining a focus on the project's goals, we can ensure a successful outcome.

The project manager is responsible for overseeing the implementation of this plan and ensuring that all team members are held accountable for their roles. Regular updates and reports will be provided to keep the stakeholders informed.