

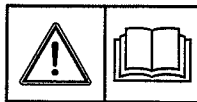

Before starting this engine, read and understand this *Operating & Maintenance Instructions*. Failure to follow these instructions could result in serious injury or death.

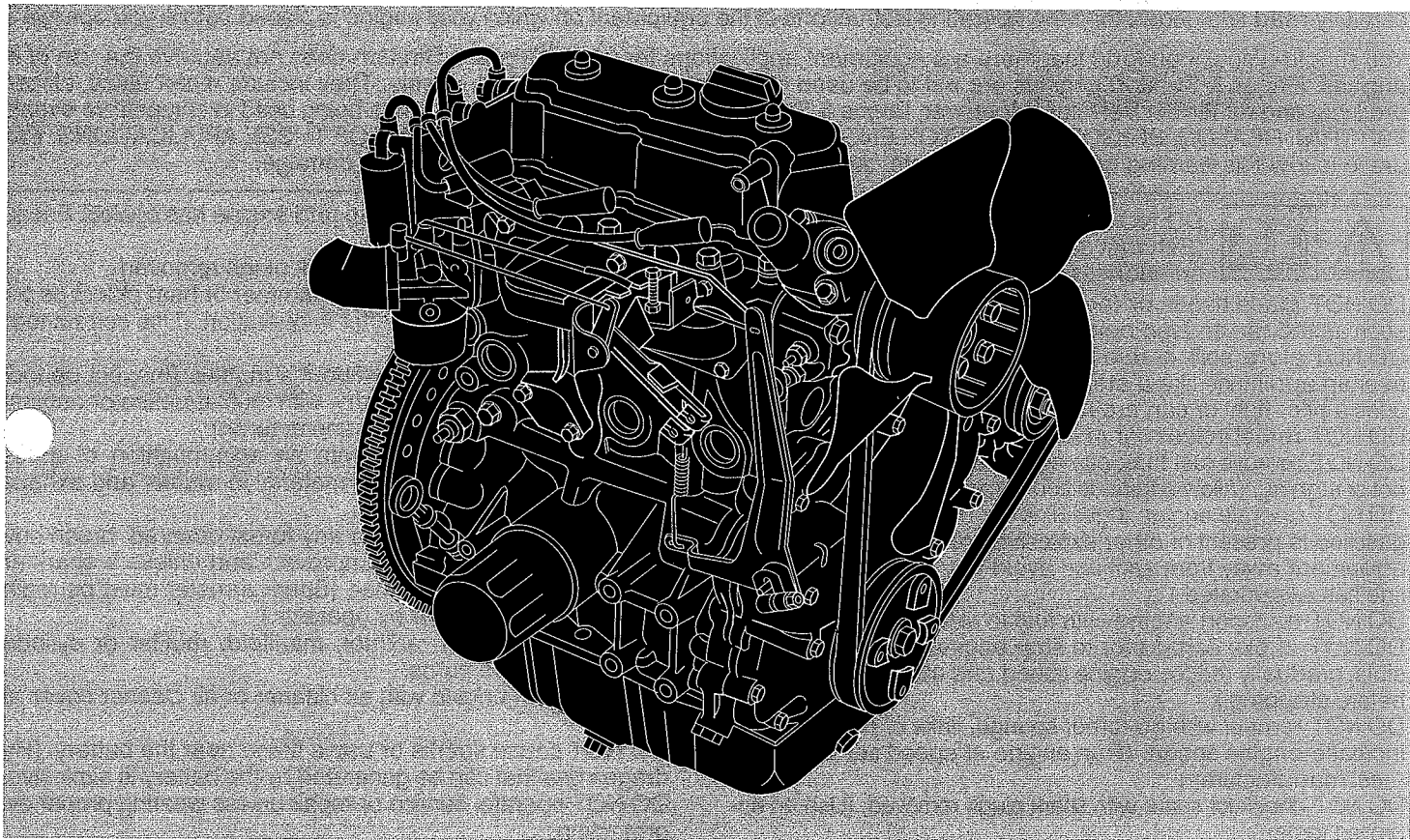

## Operating & Maintenance Instructions Gasoline Model Series 430447, 433447, 580447 & 583447



For future reference, write your Date of Purchase here. \_\_\_\_\_ →

### Table of Contents

<i>In the Interest of Safety</i> .....	2	<i>Maintenance</i> .....	6
<i>Oil, Fuel &amp; Coolant Recommendations</i> .....	3	<i>Service, Storage &amp; Specifications</i> .....	9
<i>Engine Components</i> .....	3	<i>Emission System Warranty</i> .....	10
<i>Starting &amp; Stopping</i> .....	4	<i>About Engine Warranty</i> .....	11
<i>Adjustments</i> .....	5	<i>Engine Warranty</i> .....	12

Maintenance, replacement or repair of the emission control devices and systems may be performed by any nonroad engine repair establishment or individual. However, to obtain no charge repairs under the terms and provisions of the Briggs & Stratton warranty statement, any service or emission control part repair or replacement must be performed by a factory authorized dealer.

## In the Interest of Safety



This safety alert symbol indicates that this message involves personal safety. Words danger, warning and caution indicate degree of hazard. Death, personal injury and/or property damage may occur unless instructions are followed carefully.



You are not ready to operate this engine if you have not read and understood the following safety items. Read this entire owner's manual and the operating instructions of the equipment this engine powers.

The Briggs & Stratton engine you bought with your equipment is made of the finest material in a state-of-the-art manufacturing facility. Please understand that Briggs & Stratton sells engines to original equipment manufacturers. It also sells to others in the distribution chain who may sell to the ultimate consumer, an equipment manufacturer, another distributor or a dealer. As a result, Briggs & Stratton does not necessarily know the application on which the engine will be placed. For that reason, you should carefully read and understand the operating instructions of the equipment on which your engine is placed before you operate it.

You should also understand that there are equipment applications for which Briggs & Stratton does not approve the use of its engines. Briggs & Stratton engines are not to be used on vehicles with less than 4 wheels. They include motor bikes, aircraft products and All Terrain Vehicles. Moreover, Briggs & Stratton does not approve of its engines being used in competitive events. FOR THAT REASON, BRIGGS & STRATTON ENGINES ARE NOT AUTHORIZED FOR ANY OF THESE APPLICATIONS. Failure to follow this warning could result in death, serious injury (including paralysis) or property damage.



DO NOT run engine in an enclosed area. (Exhaust gases contain carbon monoxide, an odorless and deadly poison.)

DO NOT place hands or feet near moving or rotating parts, such as the fan and fan belt.

DO NOT store, spill, or use gasoline near an open flame, nor near an appliance like a stove, furnace, or water heater that uses a pilot light or can create a spark.

DO NOT refuel indoors or in unventilated area.

DO NOT remove fuel tank cap nor fill fuel tank while engine is hot or running. (Allow engine to cool 2 minutes before refueling.)

DO NOT operate engine if gasoline is spilled or when smell of gasoline is present or other explosive conditions exist. (Move equipment away from spill and avoid any ignition until gasoline has evaporated.)

DO NOT transport engine with fuel in tank.

DO NOT choke carburetor to stop engine. (Whenever possible, gradually reduce engine speed and allow engine to cool before stopping.)

DO NOT tamper with governor springs, links or other parts to increase engine speed. (Run engine at speed set for equipment manufacturer.)

DO NOT check for spark with spark plugs removed. (Use an approved tester.)

DO NOT remove radiator cap until engine has cooled. Escaping steam can cause burns.

DO NOT crank engine with spark plugs removed.

DO NOT strike flywheel with a hammer or hard object as this may cause flywheel to shatter in operation. (Use correct tools to service engine.)

DO NOT operate engine without a muffler. (Inspect periodically and replace, if necessary, with muffler/deflector originally specified by equipment manufacturer.)

DO NOT operate engine with an accumulation of grass, leaves or other combustible material in muffler and exhaust manifold area.

DO NOT use this engine on any forest covered, brush covered, or grass covered unimproved land unless a spark arrester is installed on muffler. (Spark arrester must be maintained in working order by operator.)

DO NOT touch hot radiator, manifold, muffler or cylinder which can cause burns.

DO NOT start engine with air cleaner or air cleaner cover removed.

DO NOT cause sparks or use a flame near the battery. (Hydrogen gas that can be generated by the battery is explosive.)

DO NOT operate, service or repair unless wearing proper eye protection.

Note: The important safety instructions appearing in this manual are not meant to cover all possible conditions and situations that may occur. It must be understood that common sense, caution and care are factors which are not built into an engine, but are supplied by the person(s) maintaining and operating it.



✓ KEEP governor parts free of dirt and debris that can affect engine speed.

✓ PREVENT ACCIDENTAL STARTING by removing spark plug wires when servicing engine or equipment. Disconnect negative wire from battery terminal.

✓ USE fresh gasoline. Stale fuel can gum carburetor and cause leakage.

✓ CHECK fuel lines and fittings frequently for cracks or leaks. Replace if necessary.

✓ SHIELD eyes, protect skin and clothing when working with battery.

✓ CHECK fuel tank, fuel cap seat and fuel cap. Replace if damaged or if cap does not seal properly.

✓ Use only Genuine Briggs & Stratton Daihatsu Parts or their equivalent. The use of replacement parts which are not of equivalent quality may damage the engine.

### WARNING:

**The engine exhaust from this product contains chemicals known to the State of California to cause cancer, birth defects, or other reproductive harm.**

# Oil, Fuel & Coolant Recommendations

This engine is shipped from Briggs & Stratton Daihatsu **without oil. Before starting engine, check oil level as shown below.**

When changing or adding oil, use the chart below to select the correct viscosity grade for the temperature expected.

Do not over-fill.

Use a high quality detergent oil classified "For Service SH, SJ" or higher. Use no special additives with recommended oils.

Do not mix oil with gasoline.

## SAE Viscosity Grades

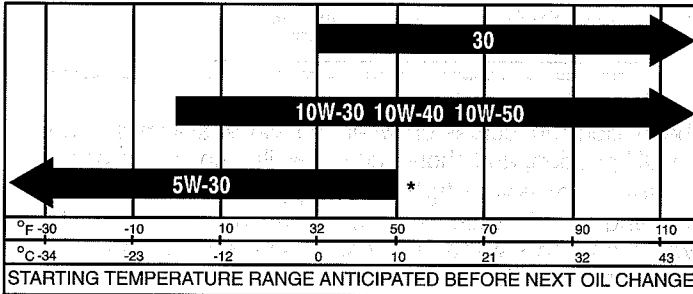

\* A synthetic 5W-30 oil may be used.

## Check oil level before starting engine.

Add oil as shown below.

Capacity, including oil filter, is approximately 3.2 quarts or 3 liters.

After filling with or changing oil, start and run engine at idle for 30 seconds. Shut engine off. Wait 30 seconds and check oil level. Add oil, if required, to bring level to **Full** mark on dipstick.

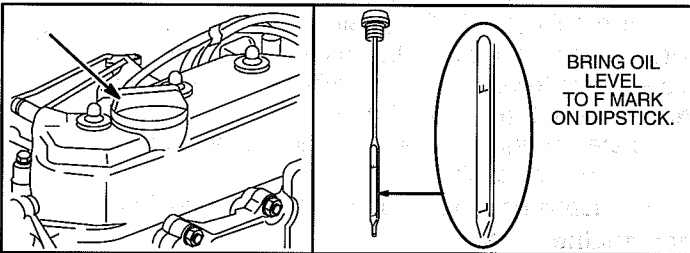

Place equipment level. Clean around oil fill.

Remove dipstick. Wipe with a clean cloth. Replace, remove and check.

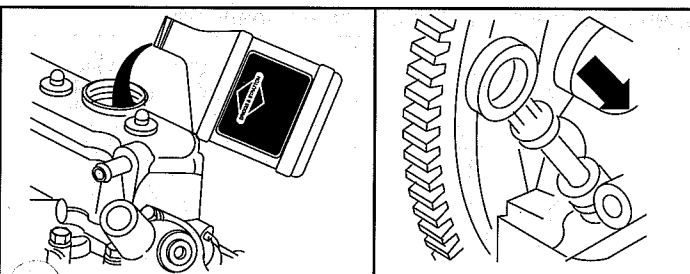

If oil is required, add slowly. Recheck.

Replace dipstick firmly before starting.

## THIS ENGINE IS CERTIFIED TO OPERATE ON GASOLINE.

**Fuel** - Use clean, fresh, unleaded gasoline with a minimum of 85 octane. Purchase fuel in quantity that can be used within 30 days to assure fuel freshness. We recommend the use of Briggs & Stratton Gasoline Additive. See storage instructions, on page 9. (See your Authorized Briggs & Stratton Service Dealer for Part No. 5041 or the single-use pouch.) In countries other than U.S.A., leaded gasoline may be used if it is commercially available and unleaded is unavailable.

**Note:** Some fuels, called oxygenated or reformulated gasolines, are gasolines blended with alcohols or ethers. Excessive amounts of these blends can damage the fuel system or cause performance problems. Do not use gasoline which contains Methanol. If any undesirable operating symptoms occur, use gasoline with a lower percentage of alcohol or ether.

**Fuel level** - Keep fuel tank full. Do not over-fill fuel tank. Allow space for fuel expansion. Check for fuel leaks at fuel filter, carburetor, fuel pump, etc.

## Coolant

This engine is water cooled. When changing or adding coolant, use a 50/50% mixture of phosphate-free antifreeze and tap water. This 50/50% mixture is required for heat dissipation, rust resistance and lubrication. Fill radiator to bottom of fill cap seat and between FULL and LOW in reservoir, if so equipped.

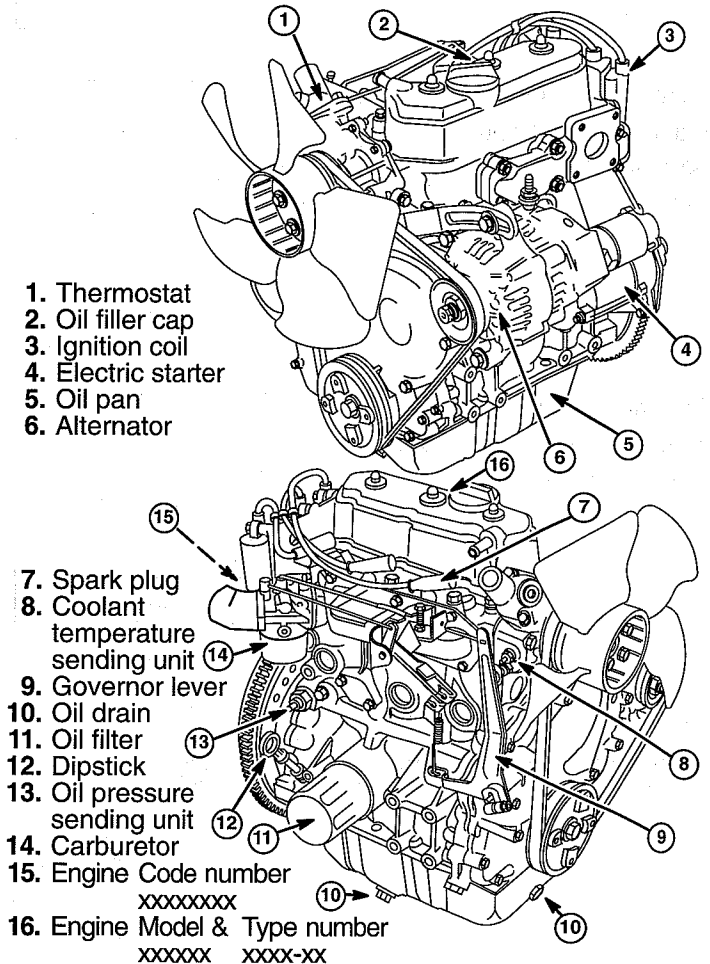

# Starting & Stopping

## Choke operation/engine warm-up

Open throttle control slightly.

If engine does not start immediately, pull choke.

After starting, allow engine to warm up a few minutes before applying load. Open choke gradually when applying load.

## Starting in cold weather:

Use the correct oil for the starting temperature expected.

De-clutch all possible external loads.

Pull choke and move throttle to FAST position.

When engine starts, release key, which will return to ON position. Gradually open choke and allow engine to warm up.

Do not use gasoline left over from summer. Use fresh winter grade gasoline which has higher volatility to improve starting.

## Typical gauges

### Coolant temperature gauge, if equipped

Indicates coolant temperature when the starter switch is ON.

Normal temperature range 80°–90° C (175°–195° F).

Dangerous temperature above 105° C (220° F).

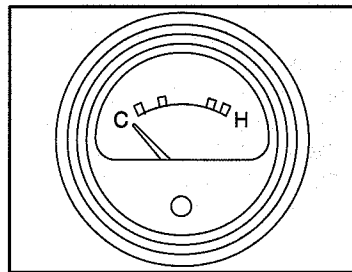

### Hour meter, if equipped

Indicates the total number of hours the engine has been run.

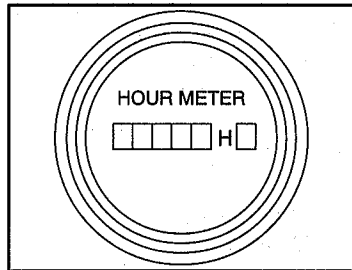

### Fuel gauge, if equipped

To minimize condensation, keep fuel tank full.

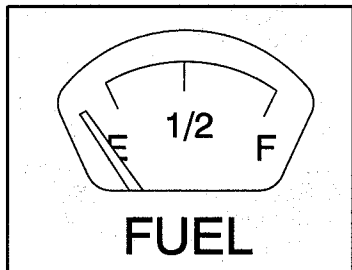

### Fuel shut-off, if equipped

Open valve before starting engine.

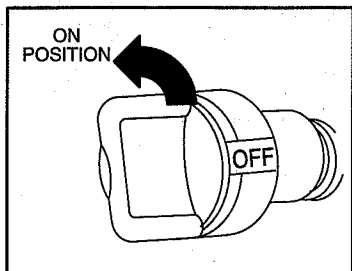

## Start engine



ALWAYS KEEP HANDS AND FEET CLEAR OF MOWER BLADE OR OTHER ROTATING MACHINERY.

Before starting engine the first time, charge battery as equipment manufacturer recommends.



Do not use a pressurized starting fluid. Starting fluid is flammable. Severe engine damage or fire may occur.

## Typical panel lights, if equipped

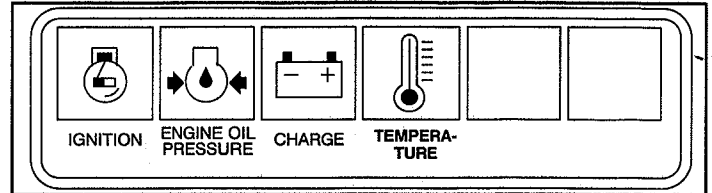

### Ignition light, if equipped

The ignition light comes on when the starter switch is turned to the ON position, and should be out while engine is running.

### Engine oil pressure light, if equipped

The engine oil pressure light comes on when the starter switch is turned to the ON position and should be out while engine is running.

### Charge light, if equipped

The charge light comes on when the starter switch is turned to the ON position, but should be out while engine is running.

1. Insert key into starter switch at OFF position.
2. Open throttle control slightly.
3. Turn key to START.

Use short starting cycles – 15 secs/min – to prolong starter life. Extended cranking can damage starter motor.

4. When engine starts, release key, which will return to ON position.

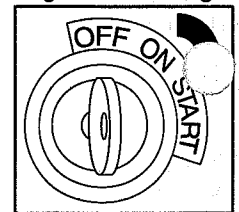

Typical starter switch

Note: If engine does not start immediately, pull choke.

Allow engine to warm up a few minutes before applying load.

### Temperature light, if equipped

If temperature light comes on, engine is overheating. Check:

- coolant level;
- debris on radiator or any restriction to air flow.

## Stop engine

Do not move choke control to CHOKE to stop engine. Backfire or engine damage may occur. Move throttle control to SLOW position. Allow engine to run for a short time to cool down. Then turn key to OFF. Always remove key from starter switch when equipment is not in use or left unattended.

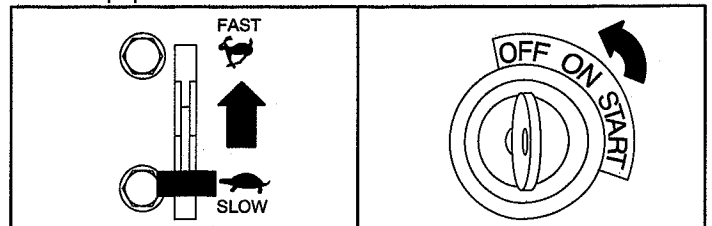

Typical throttle control

Starter switch



When engine is transported, close fuel shut-off valve or drain fuel tank to prevent leakage.

# Adjustments

## Control adjustments



The manufacturer of equipment on which this engine is installed specifies top speed at which engine will be operated. DO NOT EXCEED this speed.

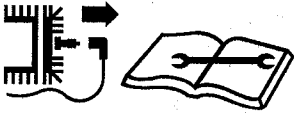

TO PREVENT ACCIDENTAL STARTING, disconnect battery at negative terminal, when adjusting controls.

If the engine is hard to start or acceleration is uneven, check control operation and adjust if required as described below.

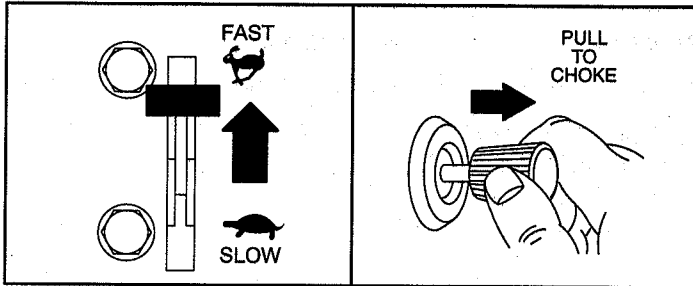

Choke and throttle controls

To adjust choke and throttle controls:

Move choke control to CHOKE position and throttle control to FAST position, loosen casing clamp screw. Then move casing and wire and engine choke lever in direction of arrow until choke valve is completely closed and/or move casing and wire and engine throttle lever in direction shown until it touches high speed screw. Tighten casing clamp screw.

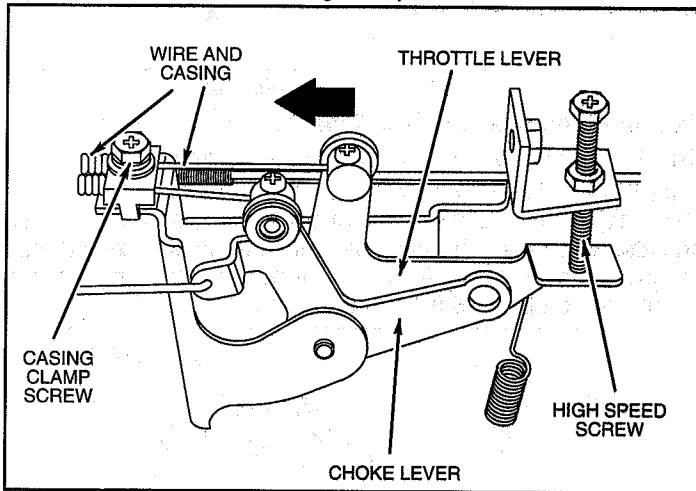

Choke and throttle control adjustment

## Carburetor adjustments

Differences in fuel, temperature, altitude or load may require minor carburetor adjustment. Air cleaner and air cleaner cover must be assembled to carburetor before starting engine.

The carburetor on this engine is low emission. It is equipped with an idle mixture valve with a limiter (see inset), which allows some adjustment, and an idle speed adjustment screw.

Before adjustment, start and warm up engine approximately 5 minutes.

### Adjustments

Place throttle control in IDLE or SLOW position. Rotate carburetor throttle lever against idle speed screw and hold. Adjust idle speed screw to obtain 1500 RPM. Turn idle mixture valve with limiter midway between limits.

Note: Engines operated at approximately 3000 to 5000 feet (900 to 1500 meters) or above sea level may require a high altitude carburetor main jet. If erratic performance is observed, contact a Briggs & Stratton Daihatsu Authorized Service Dealer for a high altitude carburetor main jet.

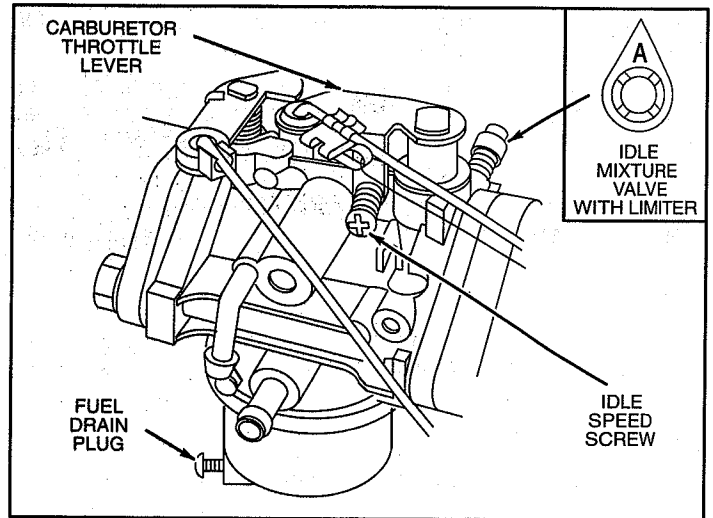

Carburetor adjustments

# Maintenance

More frequent service is required when operating in adverse conditions.

## Daily checks

### Oil

Before starting engine, check oil for correct oil level. See **Check oil level** on page 3.

**Coolant** (See **Maintenance Schedule** for intervals, page 8.)

If radiator is equipped with reservoir, check coolant level in reservoir. Coolant should be between FULL and LOW when engine is cold. If reservoir is dry, both reservoir and radiator must be filled.



If engine has been run, DO NOT remove radiator cap until engine has cooled.



Water temperature gauge should read between 175° and 195° F (80° and 90° C) when engine is warmed up. If water temperature rises above 220° F (105° C), idle engine down for a while. Then stop engine. After engine cools down, check coolant level, fan belt tension and for clogged radiator fins.

### Warning lights

If ignition light goes out when starter switch is turned to the ON position, check fuse or bulb.

If oil pressure light comes on while engine is running, stop engine immediately. Check oil level or electrical system. See an Authorized Briggs & Stratton Daihatsu Service Dealer if necessary.

If charge light comes on while engine is running, check electrical system. See an Authorized Briggs & Stratton Daihatsu Service Dealer if necessary.

### Muffler



Daily or more often, before running engine, clean muffler and manifold areas to remove all grass and combustible debris.

### Governor parts

To assure smooth operation, keep governor linkage, springs and controls free of debris.

### Regular maintenance

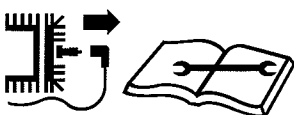

TO PREVENT ACCIDENTAL STARTING, disconnect battery at negative terminal, when servicing engine or equipment.

**Change oil** (See **Maintenance Schedule** for intervals, page 8.)

Warm up engine. Remove oil cap and drain plug. Drain oil while still warm. Replace drain plug and torque to 25.5 ft. lbs. (352 kg-cm)

Refill engine with new oil of recommended grade (see chart, page 2). Replace oil cap. Start and run engine at idle for 5 minutes. Stop engine. Wait 3 minutes and re-check oil level. If required, add oil to bring level to F mark on dipstick. Do not over-fill. Check for leaks.

**Change oil filter** (See **Maintenance Schedule** intervals, p. 8)

Remove used oil filter during oil change. Before installing new filter, lightly oil the gasket on the filter with fresh, clean oil. Screw oil filter on by hand until gasket contacts oil filter

adapter. Tighten 1/2 to 3/4 turn more. Continue oil change as described above. Check for oil leaks around filter.

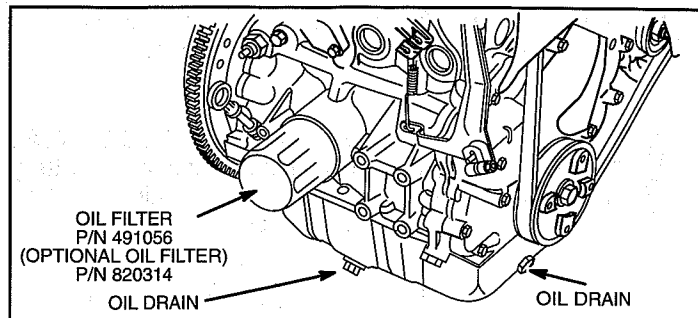

Oil drain/Oil filter

**Air cleaner** (See **Maintenance Schedule** for intervals, page 8.)

Note: Air cleaner may be supplied by equipment manufacturer.

1. Unlock clamps and remove cover.
2. Remove cartridge from air cleaner body.

Clean by tapping gently on end with the handle of a screwdriver. (Replace cartridge if very dirty or damaged.)

3. Carefully clean out air cleaner cover.
4. Install cartridge in body.
5. Install cover and lock clamps.

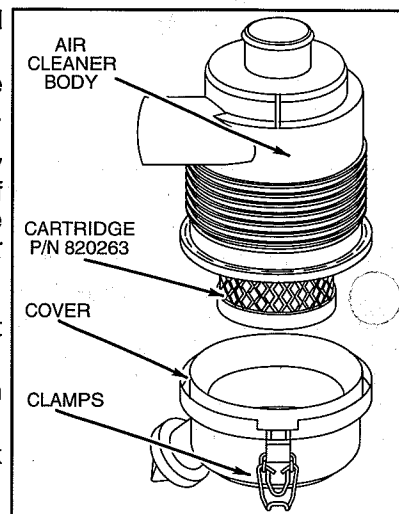

Typical air cleaner

**Fan belt** (See **Maintenance Schedule** for intervals, page 8.)

Check condition of fan belt. Replace if damaged or worn.

Check fan belt for correct tension. There should be 3/8 – 1/2 in (10 to 12 mm) belt movement at center of span between fan and alternator when pressing belt with a force of 22 lbs (10 kg). Torque alternator bolt A to 170 in-lbs (195 kg-cm). Torque alternator bolt B to 45 ft-lbs (622 kg-cm).

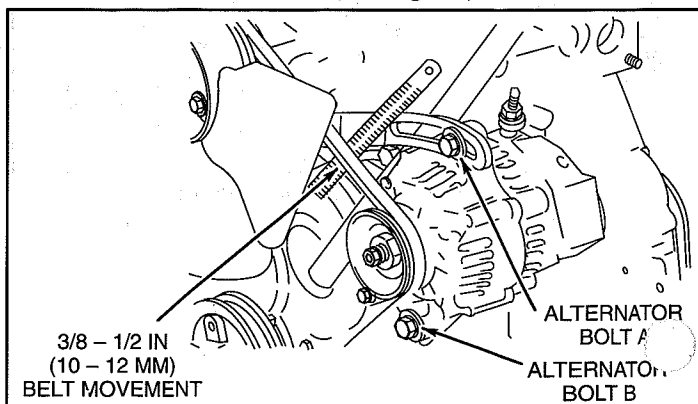

Adjusting fan belt

# Maintenance

More frequent service is required when operating in adverse conditions.

## Fan belt (See *Maintenance Schedule* for intervals, page 8.)

Check condition of fan belt for damage or wear. Replace if necessary.

Check fan belt for correct tension. There should be about 3/8 to 1/2 in (10 to 12 mm) play when pressing belt at center of span with a force of 22 lbs (10 kg).

## Fuel filter (See *Maintenance Schedule* for intervals, page 8.)

Replace fuel filter. Be sure clamps are tight and that fuel flows IN (direction of arrow).



Drain fuel tank or close fuel shut-off valve before replacing fuel filter.

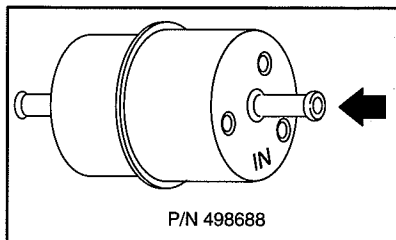

Fuel filter

## Spark plugs (See *Maintenance Schedule* for intervals, page 8.)

If required, check and re-gap spark plugs. Replace if damaged.

Use an approved spark tester to check for spark.

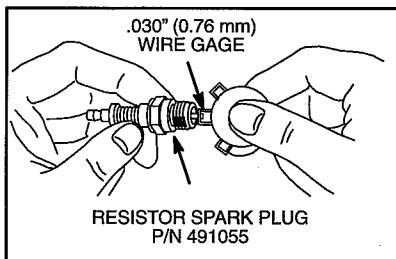

Spark plug

Note: In some areas, local law requires using resistor spark plugs to suppress ignition signals. If this engine was originally equipped with a resistor spark plug, use same type for replacement.

## Spark arrester

If engine muffler is equipped with spark arrester screen assembly, remove for cleaning and inspection every 50 hours. Replace if damaged.

## Valve clearances (See *Maintenance Schedule* for intervals, page 8.)

Note: If engine is running normally, this check and adjustment may be omitted.

With No. 1 piston at TDC of compression stroke, check valve clearances for cylinders shown in chart below. Rotate crankshaft 360° clockwise to check remaining valves. Adjust in same order, if required.

Piston Position	Cylinder	1	2	3
No. 1 piston at TDC, of compression stroke	Int	•		•
	Exh	•	•	
Rotate Crankshaft 360° clockwise	Int		•	
	Exh			•

Valve clearances (cold):

**Int** 0.007 in (0.18 mm)

**Exh** 0.007 in (0.18 mm)

Adjusting lock nut torque: 95 in-lbs (110 kg-cm).

Check valve cover gasket for leakage. Replace if required. Torque valve cover nuts to 48 in-lbs (55 kg-cm).

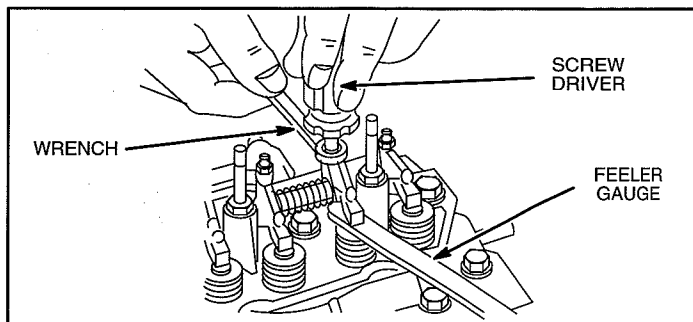

Valve clearance adjustment

See any Authorized Briggs & Stratton Service Dealer. Insist on Genuine Briggs & Stratton parts! Non-original parts may not perform as well and may void your warranty.

To obtain a complete Parts List of Genuine Briggs & Stratton Parts for your engine, fill in both sides of this order form carefully. We cannot fill your order without the correct Engine Model/Type/Code. (Please allow 3 to 4 weeks for delivery.)

Fill in both sides, clip and return to:  
**Briggs & Stratton Corporation**  
**P.O. Box 1144**  
**Milwaukee, WI 53201-1144 U.S.A.**

820824

Name \_\_\_\_\_

Address \_\_\_\_\_

City \_\_\_\_\_ State \_\_\_\_\_ Zip \_\_\_\_\_ County \_\_\_\_\_

Your Engine  
 Model

Type

Code

--	--	--	--	--	--	--	--	--	--

--	--	--	--	--	--	--	--	--	--

--	--	--	--	--	--	--	--	--	--

# Maintenance Schedule

820824

More frequent service is required when operating in adverse conditions (note 4 below).

System	Maintenance Operation	Daily	Every 50 hours	Every 100 hours	Every 200 hours	Every 600 hours	Yearly
Lubrication system	Check oil level	•					
	Check for oil leaks	•					
	Change oil		•1		•2, 4		
	Change oil filter		•1		•2, 4		
Cooling system	Check coolant	•					
	Change coolant						•
	Check fan belt			•			
Engine	Service air cleaner		•1	•2, 4		•3, 4	
	Check valve clearance					•	
Electrical system	Check battery electrolyte				•		
	Change spark plugs						•
Fuel system	Change fuel filter					•	



1. Perform first maintenance operation after 50 hours.
2. Then perform maintenance operation at this interval.
3. Replace after ever 600 hours of operation.
4. Service more often when operating under heavy load or in high temperatures.

### Briggs & Stratton Daihatsu Part Numbers of some parts:

Part	Briggs & Stratton Daihatsu Part No.
Oil .....	100028
Oil filter .....	491056
Oil filter (optional) .....	820314
Air filter .....	820263
Resistor spark plug .....	491055
Fuel filter .....	498688
Gas additive .....	5041

**Payment Method:** Fill in both sides of this order form carefully

Check or money order enclosed payable to **Briggs & Stratton Corporation** in the amount of \$ \_\_\_\_\_ (U.S. Dollars, please)

Please charge my  MasterCard   VISA 

\_\_\_\_\_ CREDIT CARD NUMBER

\_\_\_\_\_ SIGNATURE (REQUIRED FOR CREDIT CARD ORDERS)      \_\_\_\_\_ EXPIRATION DATE

**Parts List** \$2.00  
**Shipping & Handling** \$1.50  
**\*\*Add State Sales Tax** \_\_\_\_\_  
**Total** \_\_\_\_\_

Add sales tax if you live in any of the following states:  
 \*\*AL 5%, CT 6%, FL 6.5%, GA 4%, KY 6%, MI 6%, MN 6%, MO 4.225%, NY 8.5%, OH 5%, TN 6%, TX 6.25%, WA 6.5%, WI 5%

Only Genuine  
 Briggs & Stratton  
 Daihatsu Parts  
 have the  
 Briggs & Stratton logo!

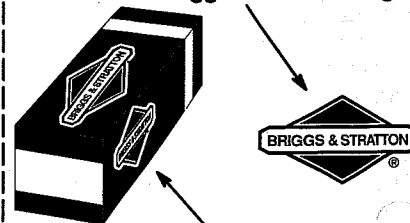

Look for Briggs & Stratton logo stamped on the package!

# Service, Storage & Specifications

## Service

See an Authorized Briggs & Stratton Daihatsu Service Dealer. Each one carries a stock of Genuine Briggs & Stratton Daihatsu Parts and is equipped with special service tools. Trained mechanics assure expert repair service on all Briggs & Stratton Daihatsu engines. Only dealers advertising as "Authorized Briggs & Stratton Daihatsu" are required to meet Briggs & Stratton Daihatsu standards.

You may locate your nearest Authorized Briggs & Stratton Daihatsu Service Dealer by calling 1-800-759-2744.

The illustrated shop manual shown here includes common specifications and detailed information covering adjustment, tune-up and repair of B&SD three cylinder, 4 cycle engines. It is available from an Authorized Briggs & Stratton Daihatsu Service Dealer or you can order it from the factory. Write:

Briggs & Stratton Corporation  
Attn: Service Division  
P. O. Box 1144  
Milwaukee, WI 53201



Part No. MS-0750

## Storage instructions

Engines stored over 30 days need to be protected or drained of fuel to prevent gum from forming in fuel system or on essential carburetor parts.

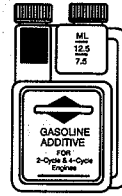

P/N 5041

1. For engine protection, we recommend use of Briggs & Stratton Gasoline Additive, Part No. 5041, available from an Authorized Briggs & Stratton Service Dealer. Mix additive with fuel in fuel tank or storage container. Run engine for a short time to circulate additive through carburetor. Engine and fuel can be stored up to 24 months.

Your Service Dealer has single-use



pouches of gasoline additive available.

Note: If engine is operating on oxygenated or reformulated gasoline (gasoline blended with an alcohol or an ether), remove all fuel from tank and run engine until it stops from lack of fuel. If engine is stored with gasoline in fuel tank, we recommend the use of gasoline additive, Part No. 5041.

2. While engine is still warm, drain oil from crankcase (see page 6). Refill with fresh oil of recommended grade (see chart page 3).
3. Remove spark plug and pour about 1 oz (30 ml) of engine oil into each cylinder. Replace spark plugs and crank slowly to distribute oil.
4. Clean dirt and chaff from cylinder, cylinder head and muffler area (see page 6).
5. Store in a clean and dry area, but NOT near a stove, furnace or water heater which uses a pilot light or any device that can create a spark.

## General information

This is a three cylinder, water cooled engine.

On mobile equipment, this engine will operate satisfactorily at any angle at which operator and equipment can function safely.

Model Series 430447, 433447

Bore ..... 2.68 in. (68 mm)  
Stroke ..... 2.52 in. (64 mm)  
Displacement ..... 42.5 cu. in. (697 cc)

Model Series 580447, 583447

Bore ..... 2.834 in. (72 mm)  
Stroke ..... 3.07 in. (78 mm)  
Displacement ..... 58.1 cu. in. (953 cc)

**Briggs & Stratton-Daihatsu L.L.C. (B&SD), the California Air Resources Board (CARB)  
and the United States Environmental Protection Agency (U.S. EPA)**

**Emission Control System Warranty Statement  
(Owner's Defect Warranty Rights and Obligations)**

EMISSION CONTROL WARRANTY COVERAGE IS APPLICABLE TO CERTIFIED ENGINES PURCHASED IN CALIFORNIA IN 1995 AND THEREAFTER, WHICH ARE USED IN CALIFORNIA, AND

TO CERTIFIED MODEL YEAR 1997 AND LATER ENGINES WHICH ARE PURCHASED AND USED ELSEWHERE IN THE UNITED STATES.

**California and United States Emission Control Defects Warranty Statement**

The California Air Resources Board (CARB), U.S. EPA and B&SD are pleased to explain the Emission Control System Warranty on your model year 2000 and later small off-road engine (SORE). In California, new small off-road engines must be designed, built and equipped to meet the State's stringent anti-smog standards. Elsewhere in the United States, new non-road, spark-ignition engines certified for model year 1997 and later, and compression-ignition engines certified for the year 2000 and later, must meet similar standards set forth by the U.S. EPA. B&SD must warrant the emission

control system on your engine for the period of time listed below, provided there has been no abuse, neglect or improper maintenance of your small off-road engine.

Your emission control system includes parts such as the carburetor, air cleaner, ignition system, muffler and catalytic converter. Also included may be connectors and other emission related assemblies. Where a warrantable condition exists, B&SD will repair your small off-road engine at no cost to you including diagnosis, parts and labor.

**Briggs & Stratton-Daihatsu Emission Control Defects Warranty Coverage**

Small off-road engines are warranted relative to emission control parts defects for a period of two years, subject to provisions set forth below. If

any covered part on your engine is defective, the part will be repaired or replaced by B&SD.

**Owner's Warranty Responsibilities**

As the small off-road engine owner, you are responsible for the performance of the required maintenance listed in your Operating & Maintenance Instructions. B&SD recommends that you retain all your receipts covering maintenance on your small off-road engine, but B&SD cannot deny warranty solely for the lack of receipts or for your failure to ensure the performance of all scheduled maintenance.

gine or a part has failed due to abuse, neglect, improper maintenance or unapproved modifications.

You are responsible for presenting your small off-road engine to an Authorized B&SD Service Dealer as soon as a problem exists. The undisputed warranty repairs should be completed in a reasonable amount of time, not to exceed 30 days.

If you have any questions regarding your warranty rights and responsibilities, you should contact a B&SD Service Representative at 1 (800) 759-2744.

**Briggs & Stratton Daihatsu Emission Control Defects Warranty Provisions**

The following are specific provisions relative to your Emission Control Defects Warranty Coverage. It is in addition to the B&SD engine warranty for non-regulated engines found in the Operating & Maintenance Instructions.

**2. Length of Coverage**

B&SD warrants to the initial owner and each subsequent purchaser that the Warranted Parts shall be free from defects in materials and workmanship which caused the failure of the Warranted Parts for a period of two years from the date the engine delivered to a retail purchaser.

**3. No Charge**

Repair or replacement of any Warranted Part will be performed at no charge to the owner, including diagnostic labor which leads to the determination that a Warranted Part is defective, if the diagnostic work is performed at an Authorized B&SD Service Dealer. For emission warranty service, contact your nearest Authorized B&SD Service Dealer as listed in the "Yellow Pages" under "Engines, Gasoline," "Gasoline Engines," "Lawn Mowers," or similar category.

**4. Claims and Coverage Exclusions**

Warranty claims shall be filed in accordance with the provisions of the B&SD Engine Warranty Policy. Warranty coverage shall be excluded for failures of Warranted Parts which are not original B&SD parts or because of abuse, neglect or improper maintenance as set forth in the B&SD Engine Warranty Policy. B&SD is not liable to cover failures of Warranted Parts caused by the use of add-on, non-original, or modified parts.

**5. Maintenance**

Any Warranted Part which is not scheduled for replacement as required maintenance or which is scheduled only for regular inspection to the effect of "repair or replace as necessary" shall be warranted as to defects for the warranty period. Any Warranted Part which is scheduled for replacement as required maintenance shall be warranted as to defects only for the period of time up to the first scheduled replacement for that part. Any replacement part that is equivalent in performance and durability may be used in the performance of any maintenance or repairs. The owner is responsible for the performance of all required maintenance, as defined in the B&SD Operating & Maintenance Instructions.

**6. Consequential Coverage**

Coverage hereunder shall extend to the failure of any engine components caused by the failure of any Warranted Part under warranty.

**1. Warranted Parts**

Coverage under this warranty extends only to the parts listed below (the emission control systems parts) to the extent these parts were present on the engine purchased.

**a. Fuel Metering System**

- |                                 |                                 |
|---------------------------------|---------------------------------|
| For Gasoline                    | For Diesel                      |
| • Carburetor and internal parts | • Injection pump with feed pump |
| • Cold start enrichment system  | • Injection nozzle              |
| • Fuel pump                     | • Fuel filter                   |
| • Fuel filter                   |                                 |
| For NG Gas, LPG Gas             | For LPG Gas                     |
| • Gas mixer                     | • Fuel metering valve           |
| • Gas regulator                 | • Venturi of gas mixer          |

**b. Air Induction System**

- Air cleaner
- Intake manifold

**c. Ignition System**

- |                               |             |
|-------------------------------|-------------|
| For Gasoline, NG Gas, LPG Gas | For Diesel  |
| • Spark plug                  | • Glow plug |
| • Ignition coil               |             |
| • Ignition processor          |             |

**d. Exhaust System**

- Exhaust manifold

**e. Miscellaneous Items Used in Above System**

- Vacuum, temperature, position, time sensitive valves and switches
- Electronic controls
- Connectors and assemblies
- Hoses

**ABOUT WARRANTY ON YOUR ENGINE: NOTE: See Back Cover For Statement Of Limited Warranty.**

Briggs & Stratton Daihatsu welcomes warranty repair and apologizes to you for being inconvenienced. Any Authorized Briggs & Stratton Daihatsu Service Dealer may perform warranty repairs. Most warranty repairs are handled routinely, but sometimes requests for warranty service may not be appropriate. For example, warranty would not apply if engine damage occurred because of misuse, lack of routine maintenance, shipping, handling, warehousing or improper installation. Similarly, warranty is void if the serial number of the engine has been removed or the engine has been altered or modified.

If a customer differs with the decision of the Service Dealer, an investigation will be made to determine whether the warranty applies. Ask the Service Dealer to submit all supporting facts to the Factory for review. If the Factory decides that the claim is justified, the customer will be fully reimbursed for those items that are defective. To avoid misunderstanding which might occur between the customer and the Dealer, listed below are some of the causes of engine failure that the warranty does not cover.

**IMPROPER MAINTENANCE:**

The life of an engine depends upon the conditions under which it operates, and the care it receives. Some applications are very often used in dusty or dirty conditions, which can cause what appears to be premature wear. Such wear, when caused by dirt, dust, spark plug cleaning grit, or other abrasive material that has entered the engine because of improper maintenance, is not covered by warranty.

**THIS WARRANTY COVERS ENGINE RELATED DEFECTIVE MATERIAL AND/OR WORKMANSHIP ONLY, AND NOT REPLACEMENT OR REFUND OF THE EQUIPMENT TO WHICH THE ENGINE MAY BE MOUNTED. NOR DOES THE WARRANTY EXTEND TO REPAIRS REQUIRED BECAUSE OF:**

1. Engines that are not properly applied to equipment. It is strongly recommended that the factory be contacted prior to applying a Briggs & Stratton Daihatsu engine to equipment that did not originally use a Briggs & Stratton Daihatsu engine.
2. PROBLEMS CAUSED BY PARTS THAT ARE NOT ORIGINAL BRIGGS & STRATTON DAIHATSU PARTS.
3. Equipment controls or installations that prevent starting, cause unsatisfactory engine performance, or shorten engine life. (Contact equipment manufacturer.)
4. Leaking carburetors, clogged fuel pipes, sticking valves, contaminated injection pumps and/or clogged injectors, or other damage, caused by using contaminated or stale fuel. (Use clean, fresh, lead-free gasoline, respectively diesel fuel and Briggs & Stratton gasoline stabilizer, Part No. 5041.)
5. Parts which are scored or broken because an engine was operated with insufficient or contaminated or incorrect grade of lubricating oil, or insufficient or inadequate cooling liquid. (Check oil level daily, top up when necessary and change oil and oil filter at recommended intervals.) Read Operator/Owner Manual.
6. Repair or adjustment of associated parts or assemblies such as clutches, transmissions, remote controls, etc., which are not manufactured by Briggs & Stratton Daihatsu.
7. Damage or wear to parts caused by dirt, which entered the engine because of improper air cleaner maintenance, re-assembly, or use of a nonoriginal air cleaner cartridge. (At recommended intervals, replace the cartridge.) Read Operator/Owner Manual.
8. Parts damaged by overspeeding, or overheating caused by grass, debris, or dirt, which plugs or clogs the radiator and/or cooling air access openings or damage caused by operating the engine in a confined area without sufficient ventilation. Engine damage caused by not using a 50/50% mix of antifreeze and tap water, or water entering the engine due to any cause.
9. Engine or equipment parts broken by excessive vibration caused by a loose engine mounting or loose or unbalanced impellers, improper attachment of equipment to engine crankshaft, overspeeding or other abuse in operation.
10. Routine tune-up or adjustment of the engine. Engine damage caused due to the use of starting fluids.

**WARRANTY IS AVAILABLE ONLY THROUGH SERVICE DEALERS WHICH HAVE BEEN AUTHORIZED BY BRIGGS & STRATTON DAIHATSU L.L.C. CALL 1-800-759-2744 FOR THE LOCATION OF YOUR NEAREST BRIGGS & STRATTON DAIHATSU AUTHORIZED SERVICE DEALERS.**

**BRIGGS & STRATTON DAIHATSU ENGINE WARRANTY POLICY**

effective  
January 1, 1995

**LIMITED WARRANTY**

"Briggs & Stratton Daihatsu LLC will repair or replace for the original purchasers, free of charge, any part, or parts of the engine that are defective in material or workmanship or both. Transportation charges on parts submitted for repair or replacement under this Warranty must be borne by purchaser. This warranty is effective for the time periods and subject to the conditions provided for in this policy. For warranty service, CALL 1-800-759-2744 for the location of your nearest Briggs & Stratton Daihatsu Authorized Service Dealer. THERE IS NO OTHER EXPRESS WARRANTY. IMPLIED WARRANTIES, INCLUDING THOSE OF MERCHANTABILITY AND FITNESS FOR A PARTICULAR PURPOSE ARE LIMITED TO ONE YEAR FROM PURCHASE, AND TO THE EXTENT PERMITTED BY LAW ANY AND ALL IMPLIED WARRANTIES ARE EXCLUDED. LIABILITY FOR CONSEQUENTIAL DAMAGES UNDER ANY AND ALL WARRANTIES ARE EXCLUDED TO THE EXTENT EXCLUSION IS PERMITTED BY LAW. Some states do not allow limitations on how long an implied warranty lasts, and some states do not allow the exclusion or limitation of incidental or consequential damages, so the above limitation and exclusion may not apply to you. This warranty gives you specific legal rights and you may also have other rights which vary from state to state."

Briggs & Stratton Daihatsu LLC

**WARRANTY PERIOD**

ENGINES	WITHIN U.S.A. AND CANADA CONSUMER AND COMMERCIAL USE*
Vanguard™ Briggs & Stratton Daihatsu Engines	<b>2-year engine, 3rd year major parts</b>

\* For purposes of this warranty policy, Parts and Labor coverage is 2 years. Major parts only coverage is extended to through the third year of operation.

**Major Parts Warranty (M.P.W.) covers** but is not limited to or exclusive to cylinder block, cylinder head, crankshaft, camshaft, gears, pistons, rods, flywheel, flywheel housing, oil pump, fan, pulleys, mechanical governor, intake manifold, oil pan.

**M.P.W. does not cover** and is not limited to piston rings, replaceable bearings, water pump, any electrical component, valve train components, accessory parts, seals, gaskets, carburetors, exhaust manifold, hoses, all fuel system components, injectors, injection pump, muffler, any filters, radiator, thermostat, spark plugs, glow plugs, fuel transfer pumps.

**NO WARRANTY REGISTRATION CARD IS NECESSARY TO OBTAIN WARRANTY ON  
BRIGGS & STRATTON DAIHATSU ENGINES.**

**YOU MUST SAVE THE PURCHASE RECEIPT. A PROOF OF PURCHASE DATE WILL BE REQUIRED TO OBTAIN  
WARRANTY.**