

Operation & Maintenance Manual

3304, 3306, 3304B and 3306B Industrial Engines

2B4364-UP
4B6032-UP
23C740-UP
66D8891-UP
10E300-UP

64Z1-UP
85Z1-UP
4XB1-UP
7JB1-UP

IMPORTANT SAFETY NOTICE

Most accidents involving engine operation are caused by failure to observe basic safety rules or precautions. An accident can often be avoided by recognizing potentially hazardous situations before an accident occurs.

Improper operation is dangerous and could result in injury or death.

READ AND UNDERSTAND ALL SAFETY PRECAUTIONS AND WARNINGS BEFORE OPERATING THIS ENGINE.

Basic safety precautions are outlined in the "Safety" Section of this Guide and in the description of operations where hazards exist. Warning decals have also been put on the engine to provide instructions and to identify specific hazards which, if not heeded, could cause bodily injury or death to you or other persons. These warnings in the Guide and on the engine decals are identified by the symbol .

Operations that may result only in engine damage are identified by CAUTION decals on the engine and in the Guide.

Caterpillar cannot anticipate every possible circumstance that might involve a potential hazard. The warnings in this Guide and on the engine are therefore not all inclusive. If an operation is not performed as specifically recommended by Caterpillar, you must satisfy yourself that it is safe for you and others. You should also ensure that the engine will not be damaged or made unsafe by the method of operation you choose.

WARNING

The proper and safe lubrication and maintenance procedures for this engine, recommended by Caterpillar, are outlined in the "Lubrication & Maintenance" Section of this Guide.

Improper performance of lubrication or maintenance procedures is dangerous and could result in injury or death. Read and understand the "Lubrication & Maintenance" Section before performing any lubrication or maintenance.

Foreword

This Operation and Maintenance Guide contains operation instructions, and lubrication and maintenance information. Application of this information should maximize performance and life of the engine; and minimize the costs of engine operation.

Caterpillar Engines are found in many applications. Therefore, the illustrations in this Guide are typical and may not be of your specific engine or application.

Familiarize yourself with the components installed on your engine as described in the instructions. Some components described in the instructions may not be on your engine or installation.

Continuing improvement and advancement of your Caterpillar product design may cause changes to your engine which may not be included in this publication.

Whenever a question arises regarding your Caterpillar product, or this publication, please consult your Caterpillar dealer for the latest available information.

The services of authorized Caterpillar dealers are recommended. Your dealer is staffed with trained personnel who are equipped with proper tools, necessary Caterpillar parts, and are trained in the latest service procedures.

Table of Contents

Model Views	2
Safety	3
Before Starting	4
Starting the Engine	5
Operating the Engine	7
Stopping the Engine	8
Gauges	10
Storage	12
Attachments	13
Maintenance Recommendations	21
Lubricants, Fuels and Coolants	23
Lubrication and Maintenance Chart	26
Refill Capacities	28
When Required	29
Every 10 Service Hours	40
Every 50 Service Hours	43
Every 125 Service Hours	45
Every 250 Service Hours	46
Every 500 Service Hours	50
Every 1000 Service Hours	51
Every 2000 Service Hours	52

Model Views

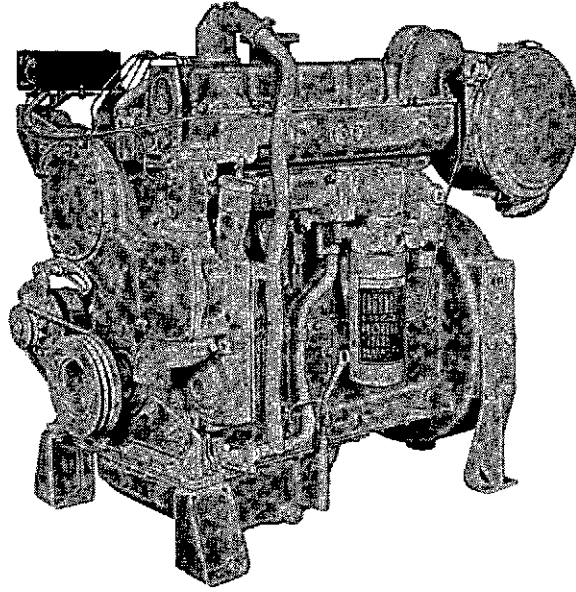

3304

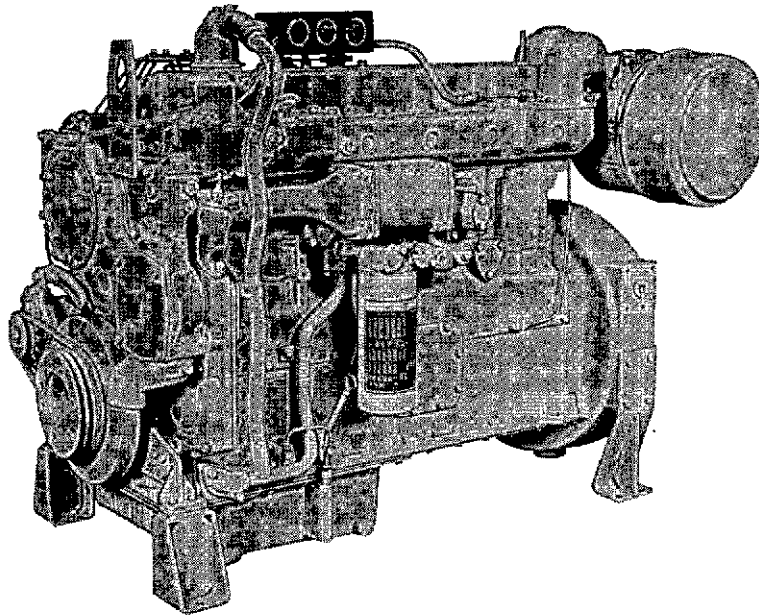

3306

Safety



THIS SYMBOL WARNS OF POSSIBLE PERSONAL INJURY

To prevent personal injury, install guards over all exposed rotating parts.

Do not attempt repairs you do not understand. Follow instructions.

Stop engine before adjusting or repairing engine or driven equipment.

Replace or repair broken or damaged servicing equipment. Use proper tools.

Do not wear loose clothing when working around engines or machinery.

Remove all tools, electrical cords and other loose items from the engine before starting.

To prevent hearing damage, wear ear protective devices if working inside an enclosed engine room with engine running.

Wipe up spilled oil, fuel, coolant or other liquids.

Wear protective glasses, clothing, hat, respirator or other protective items when necessary.

Provide adequate and safe waste oil disposal.

When using pressure air, wear protective face shield and clothing. Use 205 kPa (30 psi) maximum air for cleaning purposes.

Store oily rags in fireproof containers. DO NOT leave rags on engine.

Do not smoke while refueling. Fumes from fuel are flammable.

Never store flammable liquids near the engine.

Do not smoke when observing battery electrolyte level. Batteries give off flammable fumes.

To prevent accidental starting, disconnect and tape the battery ground lead before working on an engine.

Be sure engine room is properly ventilated.

Never start an engine with the governor linkage disconnected.

Do not allow electrolyte solution to contact skin or eyes. Electrolyte solution is an acid.

When starting an engine after repair, make provisions for shutting off air supply, to stop engine, in case there is an overspeed on start up.

Before Starting

Perform required periodic maintenance before starting the engine. Make a "walk-around" inspection of the installation. It only takes a few minutes to correct minor problems. This can prevent major repairs at a later date.

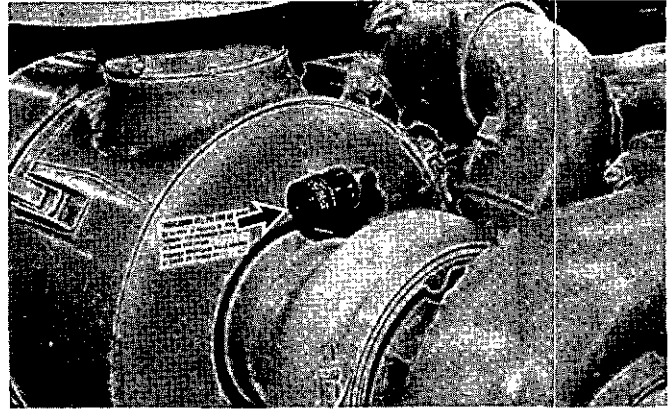

1. Inspect the air cleaner service indicator. If the red piston is locked in the raised position, service the air cleaner.

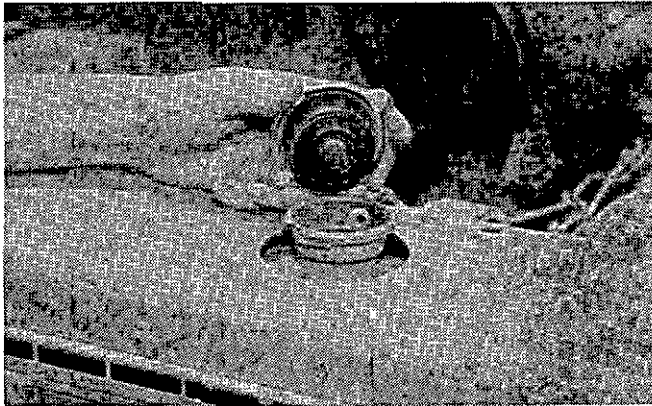

2. Inspect the coolant level. The level must be within 1 cm (1/2 inch) of the bottom of the radiator filler neck.



3. Measure the crankcase oil level. The oil level must be between ADD and FULL marks on the dipstick.

4. Inspect the fuel tank level.

5. Drain water and sediment from the water separator.

6. Disconnect any battery chargers that are not protected against the starter current drain.

7. All guards must be in place. Repair or replace all guards that are damaged.

Starting the Engine

Electric Starting

Engines Equipped With Glow Plug Starting Aid

⚠ WARNING

Starting fluid is volatile and must be stored away from heat and direct sunlight. If an aerosol container is used, follow the instructions on the container.

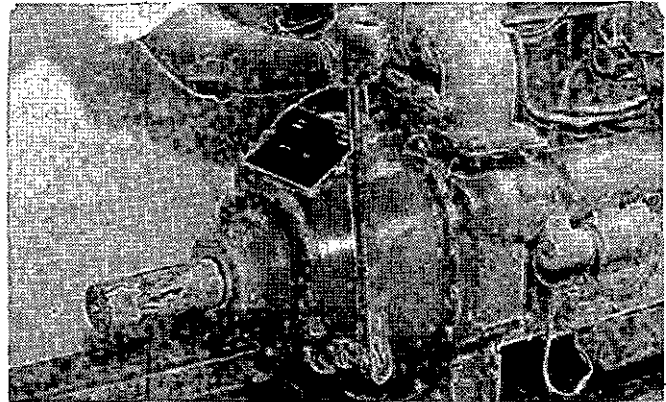

1. Place the transmission in NEUTRAL, or for generator sets, open the main electrical circuit breaker.
2. Move throttle to half engine speed.
3. Turn the battery disconnect switch to the ON position.
4. Turn the HEAT-START switch to HEAT or START, as indicated by the chart.
5. After the indicated heat time, turn the switch to the START position. If starting fluid is necessary, spray sparingly into the air cleaner inlet while the engine is cranking. (If the engine fails to start within 30 seconds, release the starter switch and wait 2 minutes, to allow the starter motor to cool, before using it again.)
6. As soon as the engine starts, allow the engine to idle 3 to 5 minutes or until the water temperature gauge has begun to rise. In cold temperatures, turn the HEAT-START switch to the HEAT position until the engine runs smoothly at low idle.
7. Do not apply load to the engine or increase engine speed until the oil pressure registers on the gauge. (Oil pressure should raise to normal within 15 seconds after the engine starts.) If oil pressure does not register within 15 seconds, stop the engine immediately to prevent damage.
8. Operate the engine at low load until all systems reach operating temperatures. Check all gauges during the warm-up period.

Starting Aid Chart

Engines Equipped With Glow Plug Starting Aid

Starting Temperature	Glow Plug Heating Time
Above 16°C (60°F)	As Required
Between 16°C and 0°C (60°F and 32°F)	1 Min.
Between 0°C and -18°C (32°F and 0°F)*	2 Min.
Below -18°C (0°F)**	3 Min.

*Use starting fluid sparingly if required.

**Heating of coolant and crankcase oil, use of starting fluid and/or use of extra battery capacity may be required.

Starting the Engine

Electric Starting

Engines Not Equipped With Glow Plug Starting Aid

If the temperature is below 16°C (60°F), a starting aid may be necessary and/or crankcase oil may need to be heated. Jacket water heaters are often used to assist starting in cold temperatures.



1. Place the transmission in NEUTRAL, or for generator sets open the main electrical circuit breaker.
2. Move the throttle to half engine speed.
3. Turn the starter switch to START. If starting fluid is necessary, spray it sparingly into the air cleaner inlet while the engine is cranking. (If the engine fails to start within 30 seconds, release the starter switch, and wait 2 minutes to allow the starter motor to cool before using it again.)
4. As soon as the engine starts, allow the engine to idle for 3 to 5 minutes, or until the water temperature gauge has begun to rise.
5. Do not apply load to the engine or increase engine speed until the oil pressure gauge indicates normal. (Oil pressure should raise within 15 seconds after the engine starts.) If oil pressure does not register within 15 seconds, stop the engine immediately to prevent damage.
6. Operate the engine at low load until all systems reach operating temperatures. Check all gauges during the warm-up period.

Air Starting

1. Open and close the bleed valve on the bottom of the air tank to drain condensation and oil carryover.
2. Check the air supply pressure. The air starter must have 7kg/cm² (100 psi) to operate properly.
3. Check the oil level in the oiler jar. Keep jar at least half full. Add oil if necessary. See the Refill Capacities Chart for the proper oil to use.

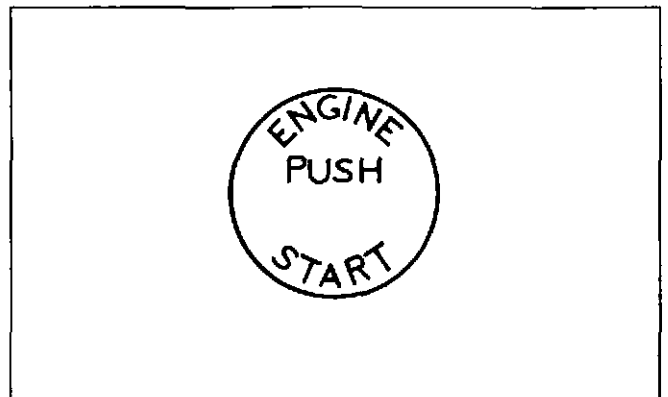

4. Pull the air valve upward or push the button to crank the engine. As soon as the engine starts, release the valve, or button.

Operating the Engine

1. Move the governor control to half engine speed.



2. Engage the driven equipment.

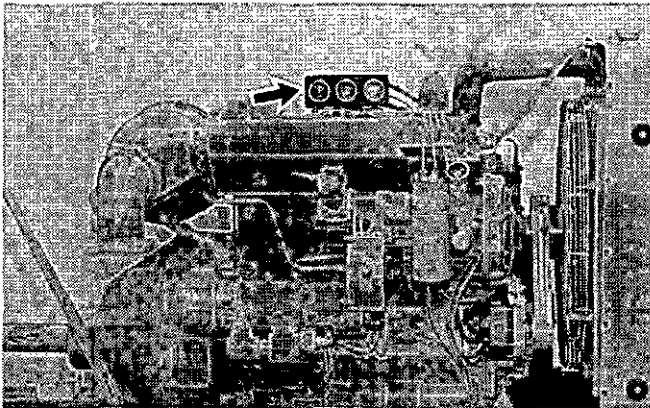

3. Check the engine gauges and equipment.

4. Move the governor control to high idle (full load) position.

5. Apply the load to the driven equipment.

Stopping the Engine

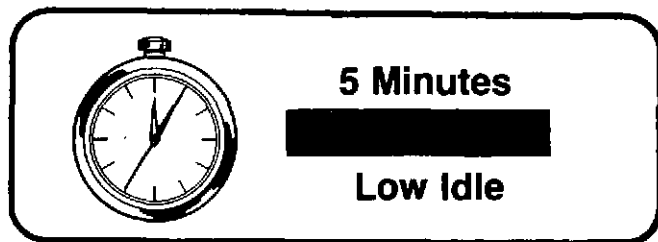

CAUTION

Stopping the engine immediately after it has been under load, can result in overheating and accelerated wear of the engine components. Follow the stopping procedure, outlined below, to allow the engine to cool, and to prevent excessive temperatures in the turbocharger center housing that will cause oil coking problems.

1. Operate the engine at low idle, with no load, for five (5) minutes.
2. Stop the engine.

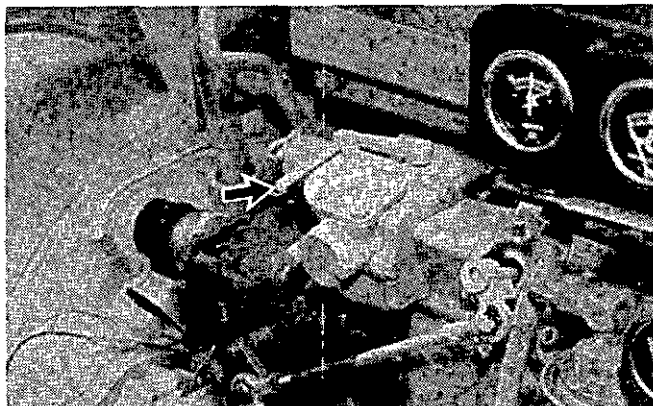

Move the governor control to the off position.

Mechanical Governor Control

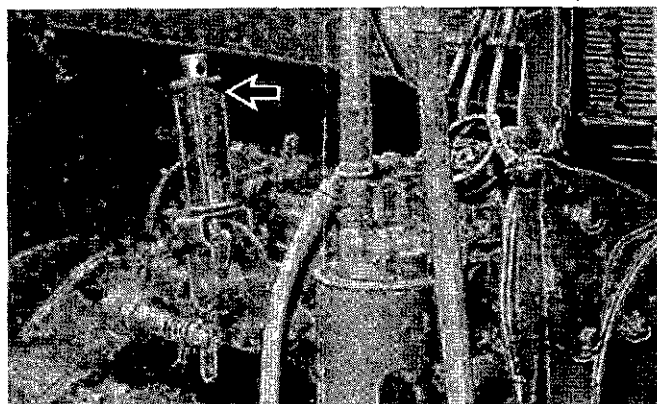

Pull upward on the hand grip, and move the control to the shut off position.

Solenoid Shutoff

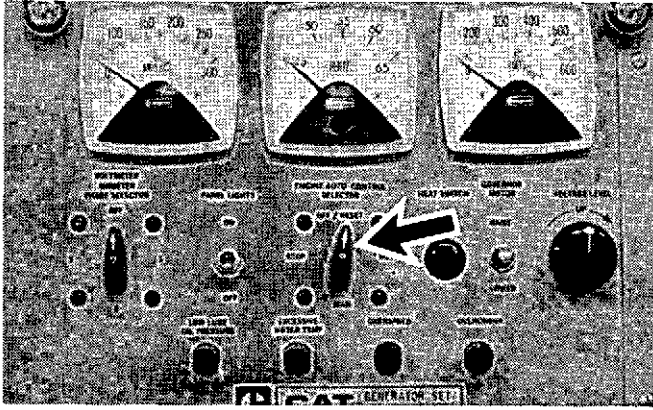

If a remote OFF/RESET switch is used, move the switch to the OFF position.

Gauges

Be sure the gauges are in good working order. You can determine what is "normal" operating range by observing and recording the gauge

readings over a period of time. The cause of any sudden or significant change in the readings should be determined and corrected.

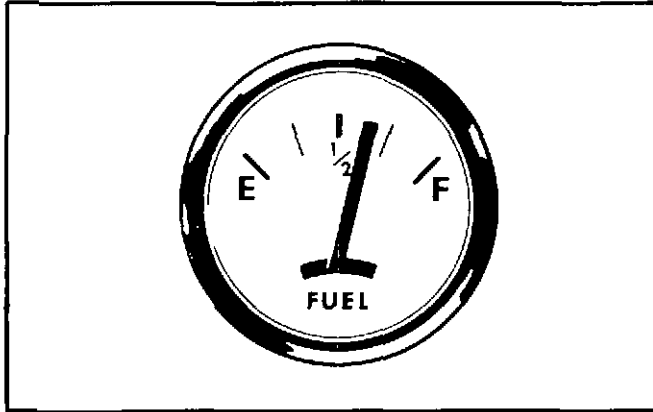

Fuel

Indicates the level of fuel in the tank. Electrically operated, it registers only when the key switch is ON.

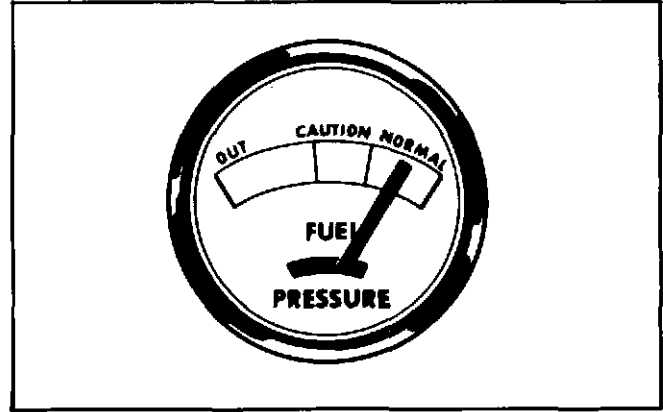

Fuel Pressure

Indicator should register in the NORMAL (green) range. When the filter element becomes clogged, the indicator moves to the OUT (red) position. Wash the primary fuel filter and replace the secondary fuel filter element.

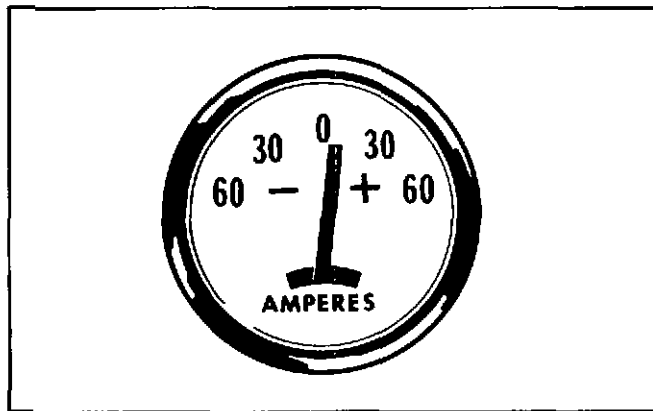

Ammeter

Indicates the rate of battery charge or discharge.

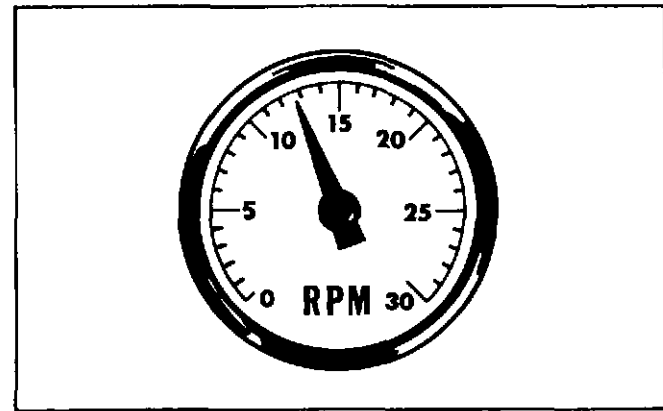

Tachometer

Indicates engine RPM.

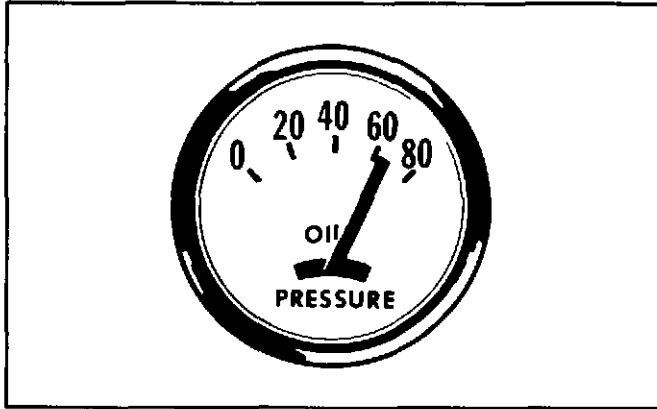

Oil Pressure

Oil Pressure will be greatest after starting a cold engine. Oil pressure will decrease as the engine warms while idling. As the engine speed is increased to full load speed, oil pressure will increase into the NORMAL range and stabilize.

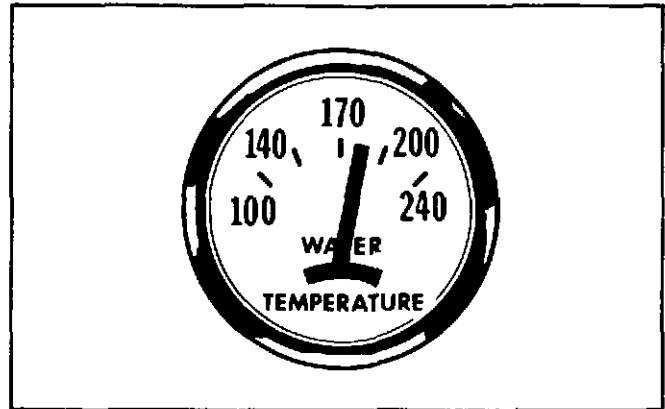

Water Temperature

The temperature of the coolant may vary according to load, but should never exceed the boiling temperature for the pressurized system being used.

Storage

If the engine is not started for several weeks, the lubricating oil drains from the cylinder walls and piston rings. This lack of oil permits the piston rings to rust; and causes metal-to-metal contact between the piston rings, the pistons and the cylinder liners when the engine is started. This metal-to-metal contact will result in shorter engine life. To prevent excessive engine wear:

1. Be sure all lubrication points listed in the "Lubrication and Maintenance Chart" are serviced.
2. Once a week, start and run the engine until it is thoroughly warm. For unattended engines with automatic start-stop systems, an engine exerciser can be installed for this purpose.

3. Stop the engine, perform required servicing.

4. If freezing temperatures can be expected, check the cooling system for adequate protection against freezing. A 50-50 solution of permanent type antifreeze and approved water will give protection below -29°C (-20°F).

If it will be impossible to start the engine every week, see your Caterpillar dealer for instructions to prepare your engine for extended storage.

Attachments

Emergency Shutoff Devices and Alarms

Emergency shutoff devices are either electrically or mechanically operated. Familiarize yourself with the types and locations of the shutoff devices, the conditions which cause each control to function, and the resetting procedure required to start the engine.

CAUTION

Always determine the cause of the shutdown. Have the necessary repairs made before restarting the engine.

Emergency shutoff controls are for emergency use only. Do not use an emergency shutoff device for a normal stopping procedure.

Electric Shutoff Controls

The operation of all electric shutoff controls is similar: A critical operating condition actuates a switch in the sensing unit. The switch closes the circuit to the shutoff solenoid which moves lin-

kage to stop the fuel to the cylinders; thus stopping the engine. The shutoff control may require resetting before the engine can start.

High Water Temperature Shutoff

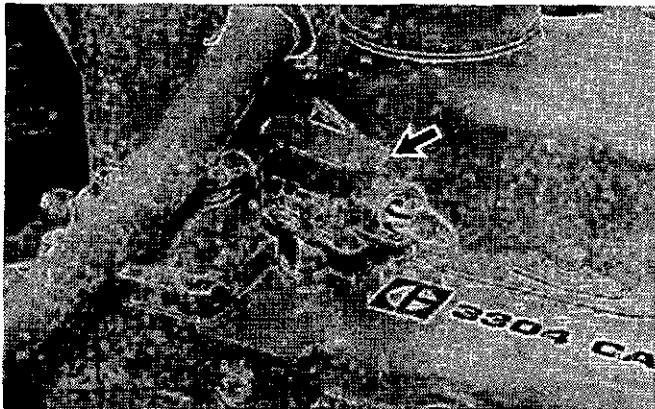

The shutoff switch is located in the water temperature regulator housing. Excessive water temperature closes the switch. No resetting procedure is required: As the coolant cools, the switch opens.

CAUTION

The sensing element must be submerged in the coolant to operate. A low coolant level cannot actuate the shutoff.

Low Oil Pressure Shutoff Switch

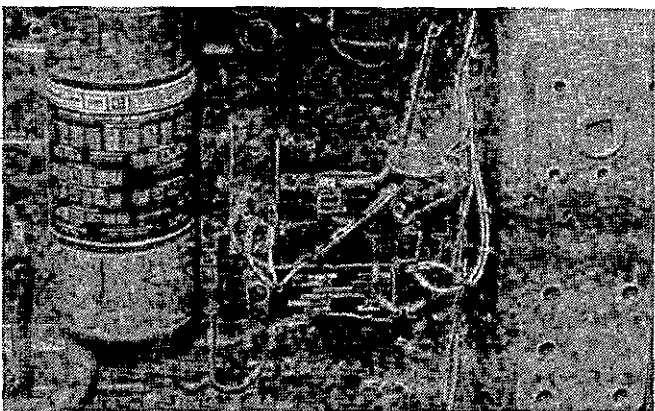

This switch is usually mounted on the side of the engine with oil lines connected to the switch. Low engine oil pressures closes the switch.

Attachments

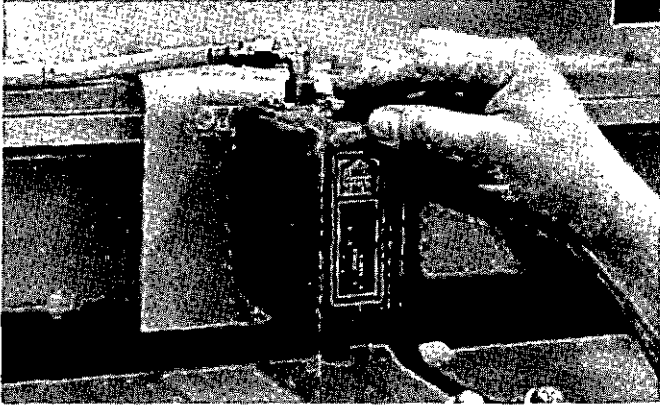

Manually operated systems require resetting by pushing the reset button until it latches. After the engine starts and develops oil pressure, the oil pressure will push the reset button to the extended running position.

CAUTION

If the reset button does not move to the extended position after the engine starts, the engine will not be protected by this switch.

If the button remains in the reset position, the engine oil pump is not developing normal oil pressure and a check should be made.

Automatic start-stop systems use a pressure switch which resets itself.

Electronic Overspeed Shutoff Switch



This switch uses a magnetic pickup mounted in the flywheel housing to sense engine speed.

Overspeed Shutoff

Should the engine overspeed, the magnetic pick-up will close the circuit to the fuel shutoff solenoid and stop the engine.

The shutoff switch can be checked for proper operation at 75% overspeed condition:

1. Determine the full load RPM of the engine from the serial number plate.

2. Operate the engine at the corresponding speed shown in the OVERSPEED TEST RPM Column of the chart below.

FULL LOAD RPM	OVERSPEED TEST RPM	ACTUAL OVERSPEED RPM
1500	1328	1770
1800	1593	2124
2000	1770	2360
2200	1947	2596

The Overspeed Test RPM is slower than the Full Load RPM:

$$\text{FULL LOAD RPM} \times .885 = \text{OVERSPEED TEST RPM}$$

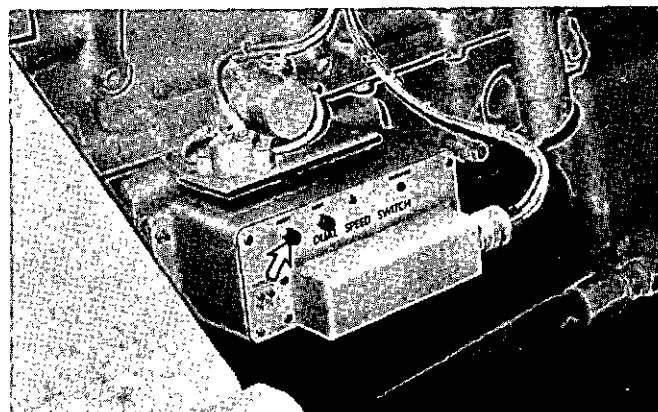

3. While maintaining test RPM, push and hold the VERIFY button. The engine should stop.

If the engine does not stop at the specified test RPM, contact your Caterpillar dealer.

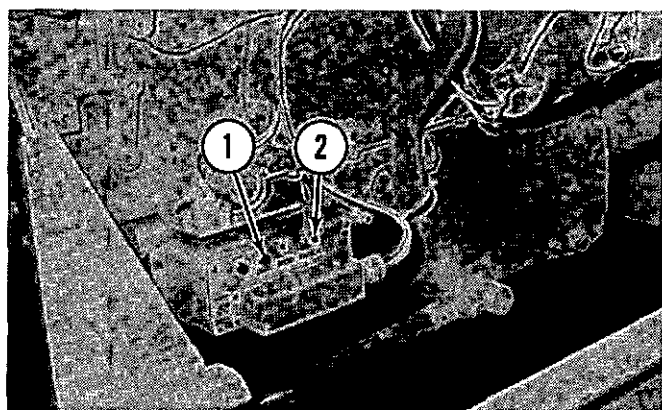

As the engine stops, the yellow light ② will go on. The RESET button ① must be pushed before starting the engine.

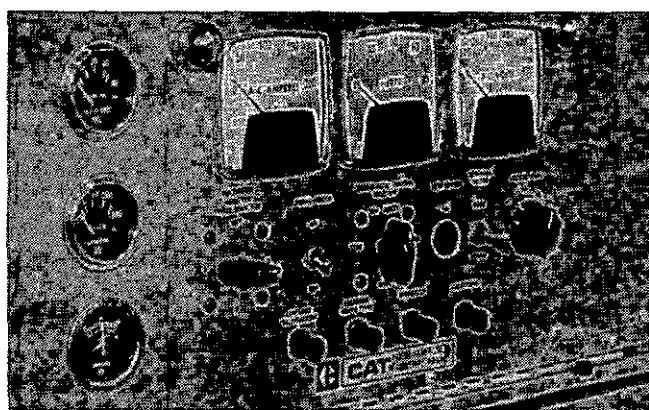

If the engine is equipped with a CAT Generator Set Control Panel, the devices on the panel must be reset:

Attachments

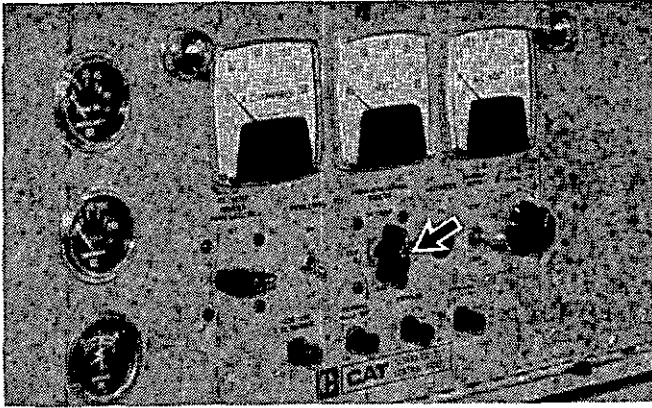

1. Turn the Engine Auto. Control Selector switch to OFF/RESET position.

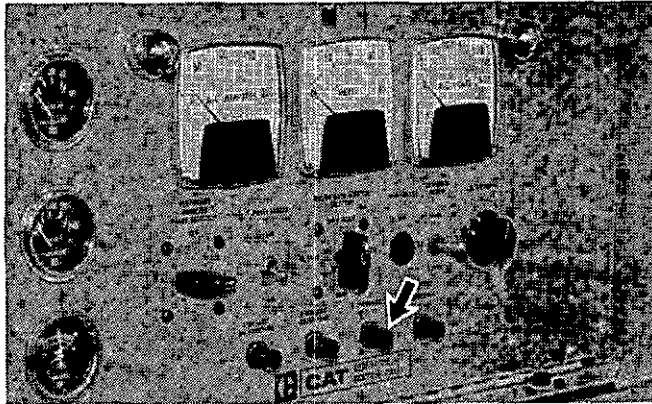

2. Push in on the OVERSPEED indicator to the reset position.

Electronic Overspeed Shutoff Switch With Cranking Termination

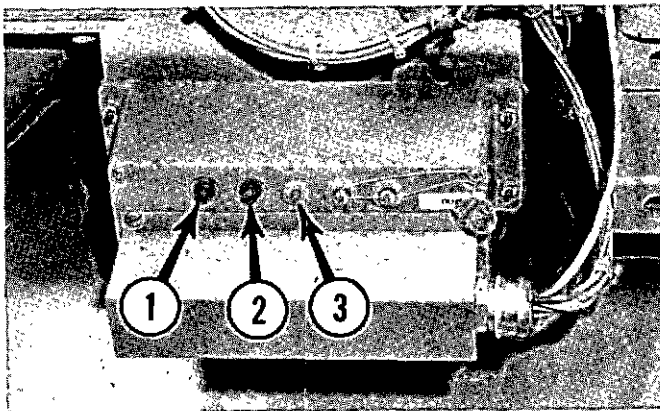

This switch has a 75% VERIFY button ①, a RESET button ② and an indicator light ③ similar to the speed switch. The operation of this portion of the switch is identical in all respects to the one just described.

In addition, this switch has a second sensing circuit which prevents the starter pinion from remaining engaged in the flywheel at excessive RPM.

After the starting motor has cranked the engine, the pinion gear can remain engaged with the flywheel as engine speed increases. At 600 RPM, the magnetic pickup opens the circuit to the

starter motor which allows the pinion to disengage. The circuit remains open until the flywheel stops. This prevents energizing the starter motor again while the flywheel is turning.

Overspeed Shutoff Switch (Electro-Mechanical)

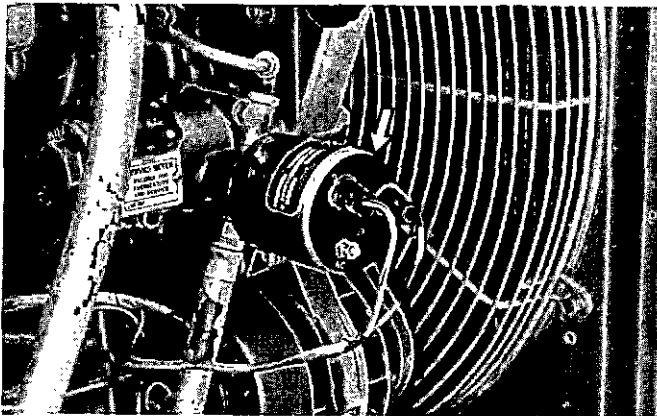

This switch is mounted either on the tachometer drive or on the governor. Excessive engine speed closes the switch by centrifugal force.

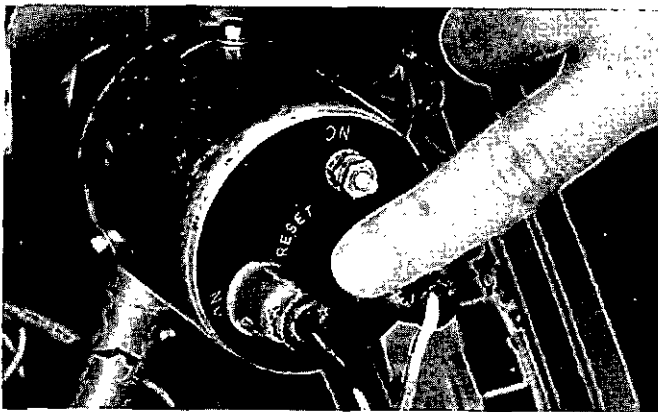

To reset the switch, push the button marked RE-SET. The knob will remain down until the engine overspeeds.

Attachments

Determine Cause of A Shutdown

CAUTION

If the engine has been shut down by a safety device, do not start the engine without having the cause of the shutdown corrected.

Woodward Governors

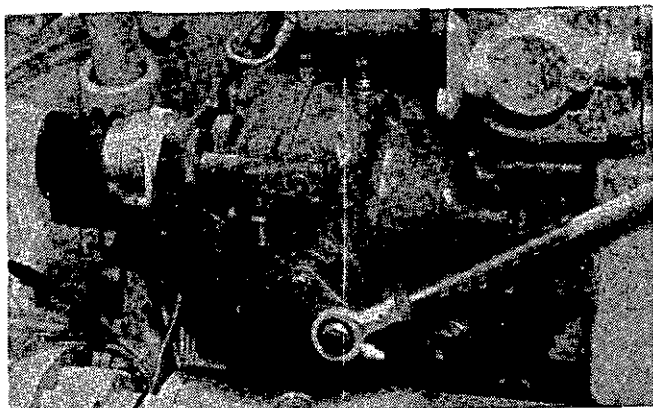

Woodward Governors are usually electrically operated from a control panel. The load application is usually a generator set operation. On standby sets the governor may be set to operate only at full load speed.

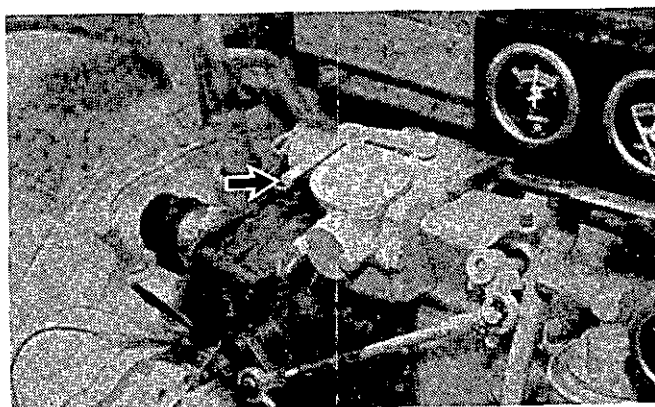

The engine may be stopped manually by moving the hand lever upward or forward, depending upon the installation.

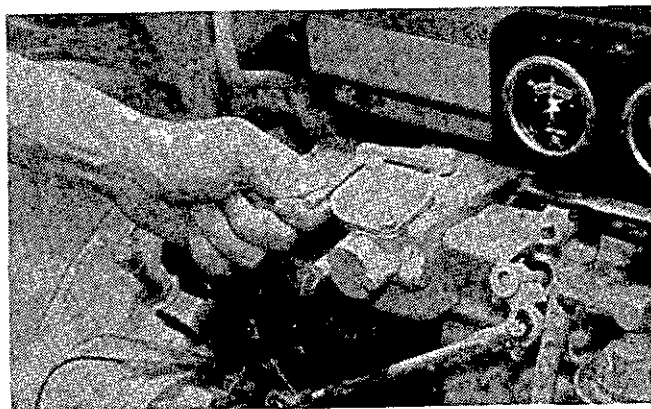

Hold the lever in the stop position until the engine stops.

To Change Engine Speed

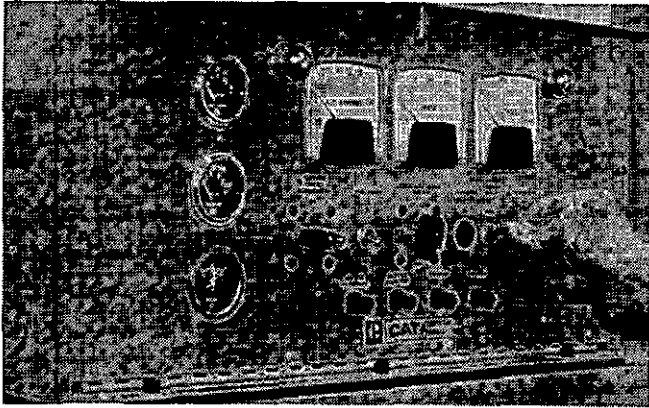

Move the "Raise-Lower" switch on the control panel to change engine speed.

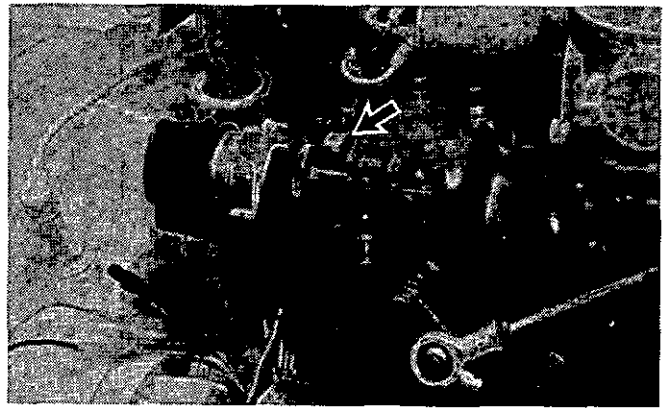

Manually turn the adjusting knob in or out to change engine speed.

To Change Speed Droop

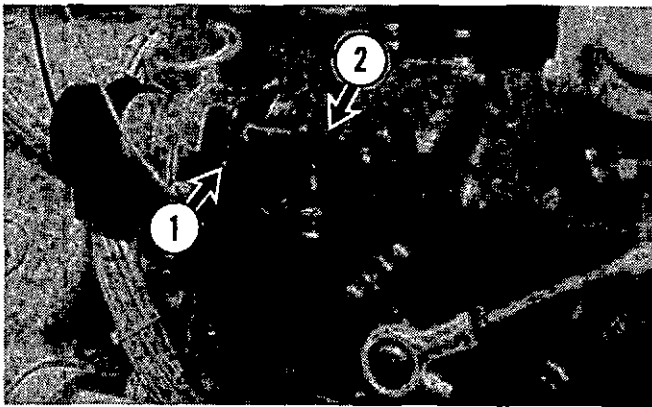

Loosen the set screw ① and move the lever ② to the upmost position for "O" speed droop.

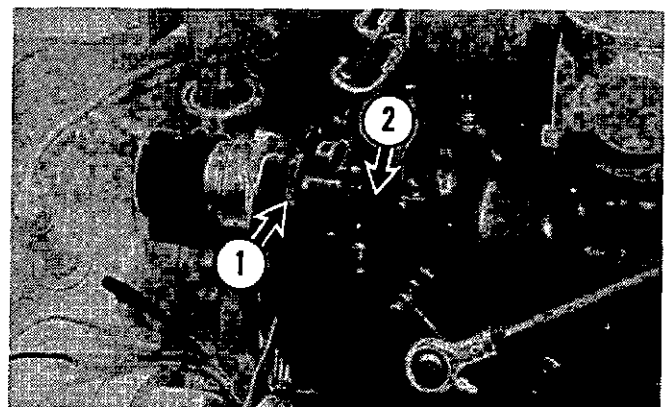

Loosen the set screw ① and move the lever ② to the lowest position for the percentage of speed droop required.

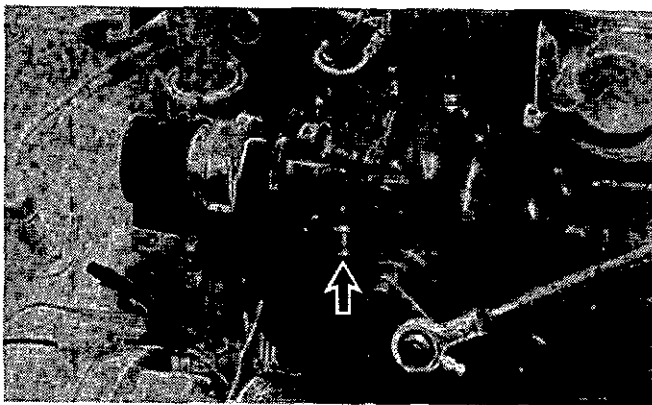

Speed droop stop used to change engine speed droop setting.

Attachments

Alarm Switches

Alarm switches are set at a less critical temperature, pressure, or level limit than the comparable shutoff control. The alarm switch warns the operator that an unsafe operating condition is starting to occur. *Corrective measures should be taken to avoid possible damage to the engine and/or a possible shutdown of the engine.*

When the preset temperature, pressure or fluid level occurs, the alarm switch will either turn on a light or an audible alarm. The light or alarm will continue to operate until the condition is corrected. *When the condition is corrected the alarm will automatically reset and the light will turn off.*

CAUTION

It could be hazardous to have the engine stop unexpectedly when engine power is needed. However, if the engine overspeeds, the engine must be stopped immediately.

CAUTION

The cause of the shutdown must be investigated and corrected before starting the engine.

Alarm Shutoff Switch

A switch may be installed in the alarm circuit for silencing the alarm while the engine is stopped for repairs. Before starting, be sure the switch is moved to the closed (ON) position, and the warning lights are lit.

CAUTION

If the switch is left in the open (OFF) position when the engine is started, the engine will not be protected.

Testing Indicator Lights

Most control panels are equipped with a test switch. Turn the switch ON, to check all of the indicator lights for proper operation. Test the in-

dicator lights periodically. Replace burned out light bulbs immediately.

Testing Shutoff Devices and Alarms

Have all shutoff controls and alarms on the engine checked twice a year by your Caterpillar dealer.

controlled testing procedures. To avoid damage to the engine, only authorized personnel should conduct these checks.

It is important that these controls function properly. Their operating condition can only be checked by simulating extreme operating conditions under

Maintenance Recommendations

Cooling

CAUTION

Never add coolant to an overheated engine; allow the engine to cool first.

Check specific gravity of antifreeze solution frequently in cold weather to assure adequate protection.

Coolant should be drained and replaced "Every 2000 Service Meter Units." With additions of Caterpillar Cooling System Conditioner or the use of Caterpillar Coolant Conditioner Elements as recommended, the drain period can be extended to "Every 4000 Service Meter Units".

All water is corrosive at engine operating temperature. The cooling system should be protected with conditioner at all times regardless of concentration of antifreeze.

When changing coolant or on initial fill, use a 3 percent solution of Caterpillar Cooling System Conditioner. This can be accomplished with .5 liter of conditioner for every 15 liters of cooling system capacity (1 pint for every 4 gallons). This concentration can be maintained by conditioner additions "Every 250 Service Meter Units." Add .5 liter of conditioner for every 76 liters of cooling system capacity (1 pint for every 20 gallons).

Most systems will require 2 liters (2 quarts) of conditioner at initial fill and .50 liters (1 pint) "Every 250 Service Meter Units."

Do not use Caterpillar Cooling System Conditioner with Dowtherm 209 Full-Fill coolant. Follow the recommendations provided with the Dowtherm 209 Full-Fill coolant.

Never use both liquid cooling system conditioner and coolant conditioner element at the same time.

When permanent antifreeze and water solutions are used in the cooling system, the solution should be drained and replaced "Every 2000 Service Meter Units".

When cooling system conditioner additions are made "Every 250 Service Meter Units" as recommended, this change period can be extended to "Every 4000 Service Meter Units or Two Years."

If the engine is to be stored or used in an area with below freezing temperatures, the cooling system must be protected to the lowest expected ambient temperature.

Operate with a thermostat in the cooling system all year-round. Problems can arise without a thermostat in the cooling system.

Use clean water that is low in scale forming minerals, not softened water.

Always recheck the coolant level when the engine reaches normal operating temperature. Add coolant as necessary to bring up to proper level.

Filling faster than 19 liters (5 U.S. gallons) per minute can cause air pockets in the cooling system.

Premix the antifreeze solution to provide protection to the lowest expected ambient temperature.

Electrical System

CAUTION

When using jumper cables to start the engine, be sure to connect in parallel: POSITIVE (+) to POSITIVE (+) and NEGATIVE (-) to NEGATIVE (-).

When using external electrical source to start the engine, turn the disconnect switch off and remove the key before attaching jumper cables.

Scheduled Oil Sampling

Use Scheduled Oil Sampling to monitor engine condition and maintenance requirements. Each oil sample should be taken when the oil is hot and well mixed to insure a sample which is representative of the oil in the compartment. Samples should be taken at each engine oil change. Consult your authorized Caterpillar engine dealer for complete information and assistance in establishing a scheduled oil sampling program for your engine.

Maintenance Recommendations

Fuel System

CAUTION

Fill the fuel tank at the end of each day of operation to drive out moisture laden air and to prevent condensation. Do not completely fill the tank. The fuel expands when it gets warm and may overflow.

Water and sediment should be drained from the fuel tank at the start of each shift or after the fuel tank has been filled and allowed to stand for 5 to 20 minutes. Drain the fuel tank and water separator of moisture and sediment as required by prevailing conditions.

After changing the fuel filters, always prime the fuel system to remove air bubbles.

General

CAUTION

Accumulated grease and oil on the engine is a fire hazard. Remove this debris with steam cleaning or high pressure water, at least every 1000 service meter units or each time any significant quantity of oil is spilled on the engine.

Wipe all fittings, caps and plugs before servicing.

GENERAL TIGHTENING TORQUE FOR BOLTS AND NUTS

The following charts give the standard torque values for bolts and nuts of SAE Grade 5 or better quality.

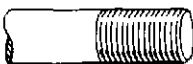

Standard thread		Use these torques for bolts and nuts with standard threads (conversions are approximate).	
			
THREAD DIAMETER		STANDARD TORQUE	
inches	millimeters	lb. ft.	N·m
1/4	6.35	9 ± 3	12 ± 4
5/16	7.94	18 ± 5	25 ± 7
3/8	9.53	32 ± 5	45 ± 7
7/16	11.11	50 ± 10	70 ± 15
1/2	12.70	75 ± 10	100 ± 15
9/16	14.29	110 ± 15	150 ± 20
5/8	15.88	150 ± 20	200 ± 25
3/4	19.05	265 ± 35	360 ± 50
7/8	22.23	420 ± 60	570 ± 80
1	25.40	640 ± 80	875 ± 100
1-1/8	28.58	800 ± 100	1000 ± 150
1-1/4	31.75	1000 ± 120	1350 ± 175
1-3/8	34.93	1200 ± 150	1600 ± 200
1-1/2	38.10	1500 ± 200	2000 ± 275

Lubricants - Fuels - Coolants

Fuel Specifications

Types of Fuel

Caterpillar Engines have the ability to burn a wide variety of fuels. These fuels are divided into two general groups, Preferred and Permissible.

The Preferred Fuels provide maximum engine service life and performance. These are distillate fuels. They are commonly called fuel oil, furnace oil, diesel fuel, or kerosene.

The Permissible Fuels are crude oils or blended fuels. Use of these fuels can result in higher maintenance costs and reduced engine service life.

See Caterpillar Form Number SEHS7067 Preferred and Permissible Fuels and their specifications.

Cetane Requirement

The minimum cetane number recommended for this engine is 35 for PC engines.

The minimum cetane number recommended for this engine is 40 for DI engines.

Fuel Cloud Point

In cold weather, the cloud point of the fuel must be below the temperature of the surrounding air. If the cloud point is too high, wax will form in the fuel, which will cause clogging of the fuel filters and loss of power. Fuel heaters are available which will permit the use of a fuel with a high cloud point or a fuel with a lower cloud point should be used.

Fuel Sulfur Content

The percentage of sulfur in the fuel will affect the engine oil recommendations. If the fuel has over 0.5% sulfur content, the engine oil must have a TBN of 20 times the percentage of fuel sulfur (TBN as measured by the ASTM D-2896 method). If the sulfur content is greater than 1.5%, consult your Caterpillar dealer for correct engine oil recommendations.

Coolant Specifications

Engine Coolant

Use a mixture of fill water, antifreeze and Cooling System Conditioner. Caterpillar Form Number SEBD0518 entitled, "Know Your Cooling System" can provide more detailed specifications.

Fill Water

Always add conditioner to water. Never use plain water.

Acceptable water for use in the ethylene glycol-type antifreeze and water mixture is shown on the chart below:

Acceptable Water		
Water Content	50% Antifreeze 50% Water	Without Antifreeze
Chlorides	100 ppm or less	50 ppm or less
Sulfates	100 ppm or less	50 ppm or less
Hardness as CaCO ₃	200 ppm or less	100 ppm or less
Dissolved Solids	500 ppm or less	250 ppm or less
pH	6.5 or higher	6.5 or higher

ppm = parts per million

Antifreeze

Use ethylene glycol-type antifreeze. Use the correct amount to provide freeze protection to the lowest expected temperature.

Lubrication and Maintenance Chart

Item	Procedure	Lube.	Page
When Required			
Cooling System	Drain and clean when solution is dirty		29
Air induction system ⁽¹⁾	Install clean filter elements when air cleaner indicator piston locks in the "UP" position. Clean precleaner		30
Fuel System Sleeve Metering System New Scroll Fuel System	Change filters every 500 service hours or when fuel gauge registers "OUT" with engine running. Prime the fuel system when required.		35
Air Starter	Fill motor oiler jar—Empty collector jar—Adjust oiler feed	CD	37
Batteries	Clean batteries and electrical connections		38
Glow Plugs	Inspect if a defective glow plug is suspected		39
Clutch	Inspect—Adjust if necessary		39
Every 10 Service Meter Units			
① Engine Crankcase	Check the oil level—add oil as required.	CD	40
② Air Cleaner Indicator	If the red piston locks in the "UP" position, service the element.		40
③ Fuel Tank	Drain water and sediment.		40
④ Water Separator	Drain water and sediment. Install new element when glass becomes clouded.		41
⑤ Cooling System	Inspect coolant level.		41
⑥ Clutch Shift Collar	Lubricate 1 fitting.	MPG	42
Every 50 Service Meter Units			
⑦ Dust Collector	Empty dust cap and clean tubes. May be required more often in dusty conditions.		43
⑧ Batteries	Observe electrolyte level.		43
Every 125 Service Meter Units			
⑨ Clutch Control Lever	Lubricate 2 fittings.	MPG	45
⑩ Clutch Pilot Bearing	Lubricate 1 fitting.	MPG	45
⑪ Clutch Main Shaft Bearing	Lubricate 1 fitting.	MPG	45
Every 250 Service Meter Units			
⑫ Alternator Belts	Inspect and adjust if necessary.		46
⑬ Engine Crankcase ⁽²⁾	Turbocharged engines—Change oil and filter. Clean the engine breather.	CD	47
⑭ Cooling System	Add cooling system conditioner.		49

Item	Procedure	Lube.	Page
Every 500 Service Meter Units			
15 Engine Crankcase ⁽²⁾	Naturally Aspirated engines—Change oil and filter. Clean the engine breather.	CD	50
16 Fan Bearing	Lubricate 1 fitting.	MPG	50
16A Fuel System Sleeve Metering System New Scroll Fuel System	Clean primary fuel filter and change final fuel filter.		50
Every 1000 Service Meter Units			
17 Woodward PSG Governor	Lubricate 2 fittings.	MPG	51
Synchronizing Motor	Oil.	CD	51
18 Shutoff Controls	Have operation checked by Caterpillar dealer.		51
19 Tachometer Drive	Lubricate 1 fitting.	MPG	52
Every 2000 Service Meter Units			
20 Engine Valve Lash	Measure—Adjust if necessary. Observe rotation of valves with engine idling.		53
21 Cooling System	Change antifreeze solution.		57

(1) Service intervals may be shortened in dusty operating conditions. If the exhaust smoke and/or loss of power continues after servicing the air cleaner, discard that element and install a new element. Install a new element at least once a year.

(2) The percentage of sulfur in the fuel will affect the engine oil recommendations. If the fuel has over 0.5% sulfur content, the CD engine oil must have a TBN of 20 times the percentage of fuel sulfur (TBN as measured by the ASTM D-2896 method). If the sulfur content is greater than 1.5%, consult your Caterpillar dealer for correct engine oil recommendations.

Refill Capacities

Refill Capacities (Approximate)	Liters	Gals.	Imp. Gals.
3304 ENGINE LUBRICATION SYSTEM:	19	5	4
Cooling System (Engine Only):	17	4.5	3.75
3306 ENGINE LUBRICATION SYSTEM:	27.5	7.25	6
Cooling System (Engine Only):	20	5.25	4.5

When Required

Cooling System—Cleaning

⚠ WARNING

At Operating Temperature, engine coolant is hot and under pressure.

Steam can cause personal injury.

Check coolant level **ONLY** when engine is stopped and radiator cap is cool enough to touch with your hand.

Remove filler cap slowly to relieve pressure.

Cooling System Conditioner contains alkali. Avoid contact with skin and eyes to prevent personal injury.

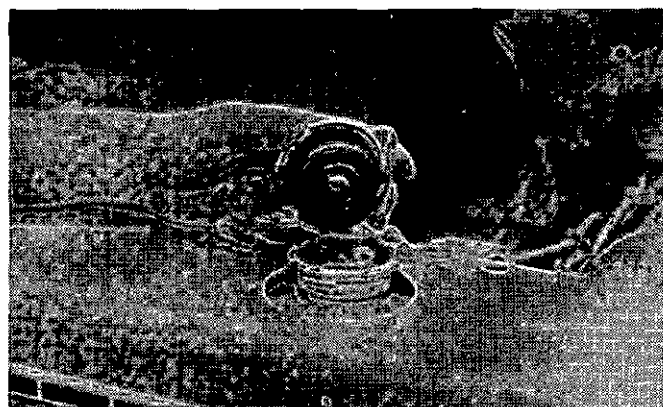

1. Loosen radiator cap slowly to release pressure and remove filler cap.

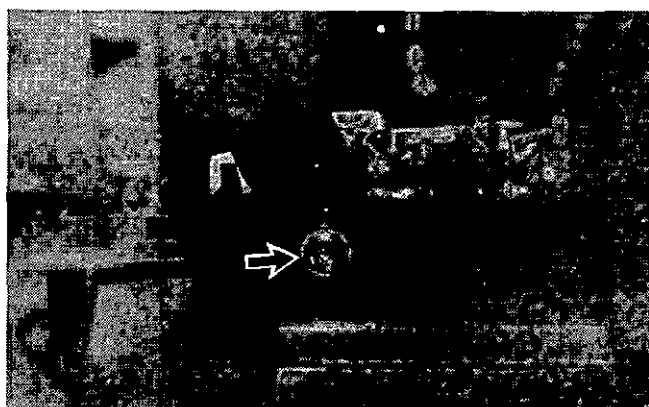

2. Remove radiator drain plug.



3. Remove the engine block drain plug.

CAUTION

If the engine is to be stored in, or shipped to, an area with below freezing temperatures, the cooling system must either be protected to the lowest expected ambient temperature, or drained completely.

Never add coolant to an overheated engine, allow engine to cool first.

Do not use Caterpillar Cooling System Conditioner or Coolant Conditioner Elements with Dowtherm 209 Full-Fill coolant.

⚠ WARNING

Use all cleaning solutions with care.

When Required

4. Install drain plugs. Fill system with a commercially available cleaning solution or 1 kilogram (2 lb.) Sodium Bisulfate (NaHSO_4) per 40 liters (10 U.S. gallons) water.

5. Start and run for 1/2 hour. Stop engine and drain cleaning solution.

6. Flush system with clean water until draining water is clean. Do not run engine while flushing.

7. Install all drain plugs. Fill system with neutralizing solution or 250 grams (1/2 lb.) Sodium Carbonate Crystals ($\text{Na}_2\text{CO}_3 \cdot \text{H}_2\text{O}$) per 40 liters (10 U.S. gallons) water.

8. Start and run engine for 10 minutes. Stop engine and drain neutralizing solution.

9. Flush system with clean water, until draining water is clean. Do not run engine while flushing.

10. Install all drain plugs.

11. Fill engine with clean water. Run the engine for 10 minutes and drain.

Repeat until drained water is clean.

12. Add 1 liter (1 quart) of Caterpillar Cooling System Conditioner, or equivalent, for each 30 liters (8 gallons) of cooling system capacity so cooling system will have a 3% to 6% concentration of conditioner.

Most systems will require 2 liters (2 quarts) of conditioner at initial fill and .50 liters (1 pint) "Every 250 Service Hours."

13. Mix antifreeze and water to provide protection to the lowest expected ambient temperature.

14. To help avoid air locks, add coolant slowly, at 19 liters (5 U.S. gallons) per minute or less.

Air Induction System—Changing Elements

Single Stage Air Cleaner

CAUTION

Service the air cleaner with the engine stopped.

Service the air cleaner when the red plunger in the indicator locks in the visible position.

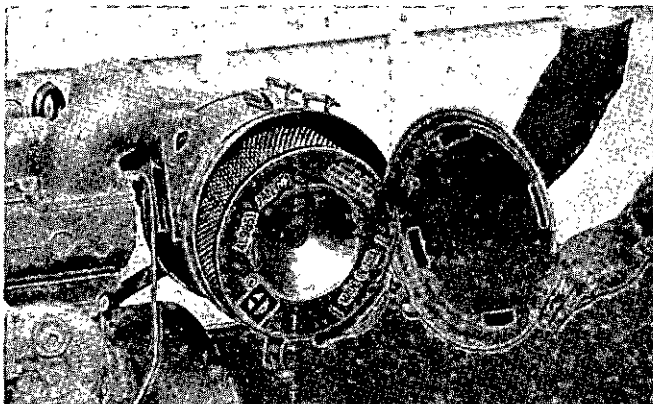

1. Remove the air cleaner cover and element.

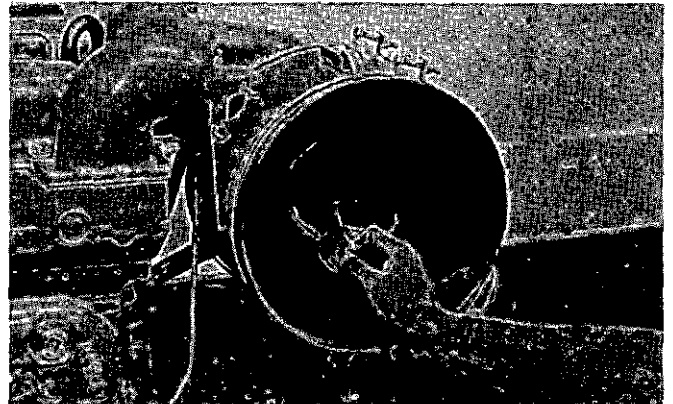

2. Cover the turbocharger inlet opening.

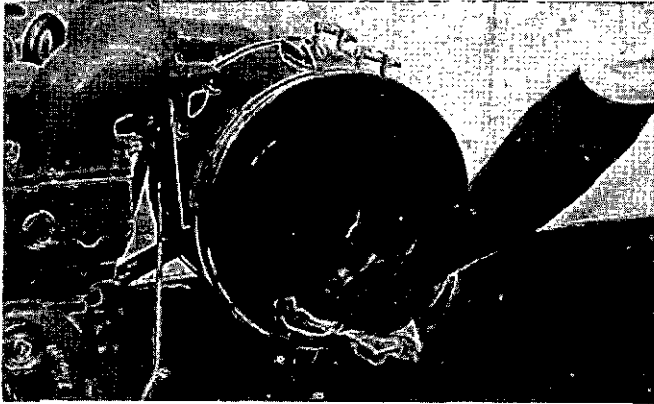

3. Clean the inside of the air cleaner cover and body.

4. Inspect the replacement element for damage and dirt.

5. Remove the covering from the turbocharger inlet opening.

6. Install a clean undamaged element.

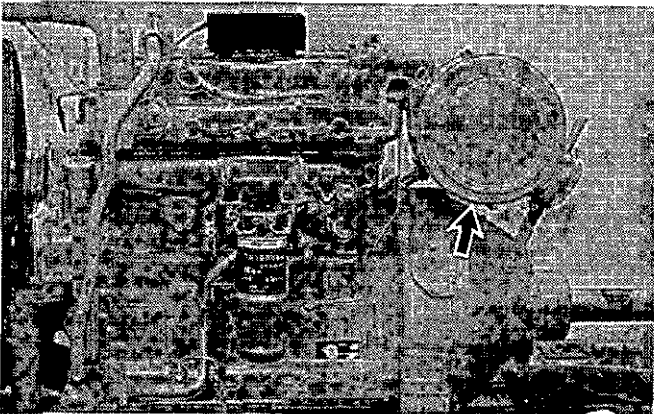

7. Install the air cleaner cover.

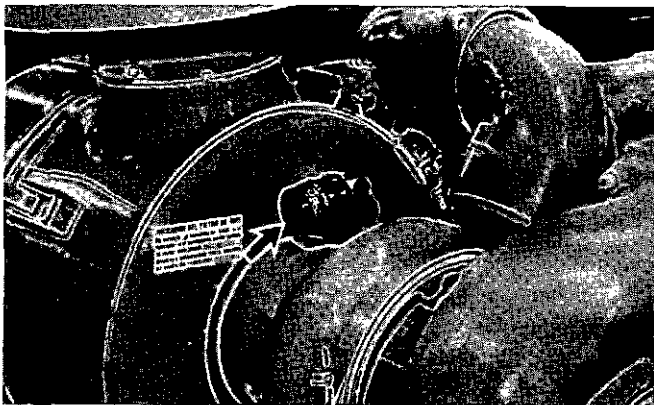

8. Reset the service indicator.

When Required

Two Stage Air Cleaner

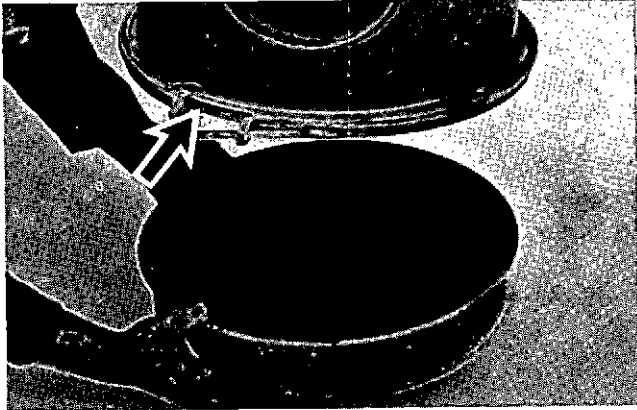

1. Loosen the clamping bolt on the lower body.
2. Remove and empty the dust collector cup.

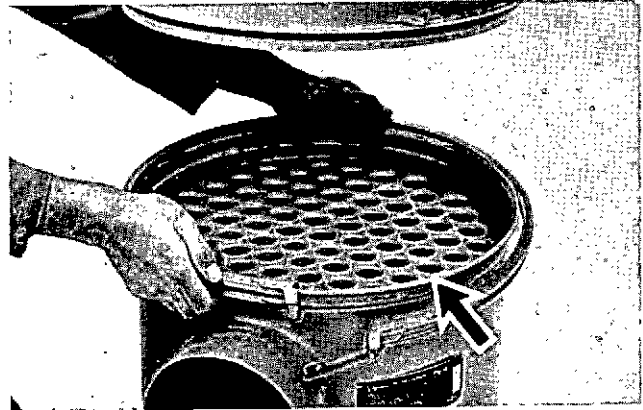

3. Loosen the clamping bolt on the upper body.

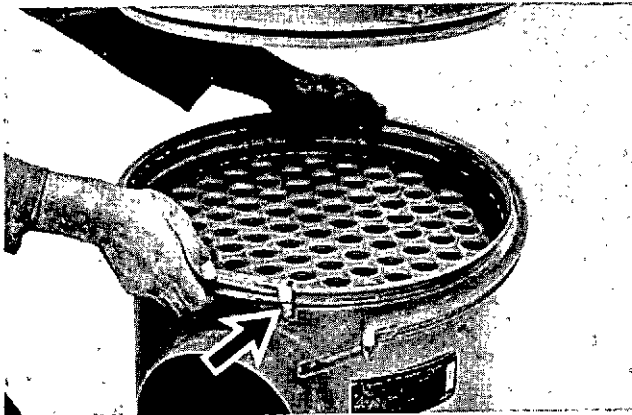

4. Remove the lower body and clean the tubes from both ends.

5. Inspect the seals between the lower body and the dust collector cup, and between the lower body and upper body. Install new seals if necessary.

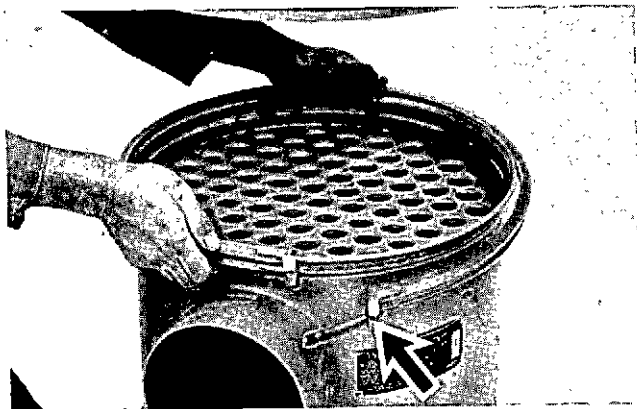

6. Install the lower body to the upper body and tighten the retaining clamp.

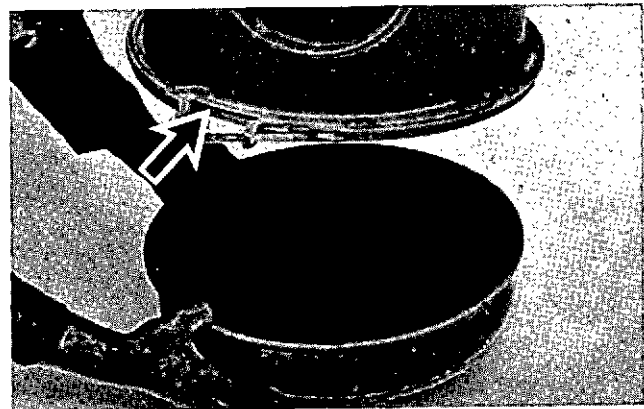

7. Install the dust cup and tighten the retaining clamp.

Installing Replacement Filter Elements For Two Stage Air Cleaner

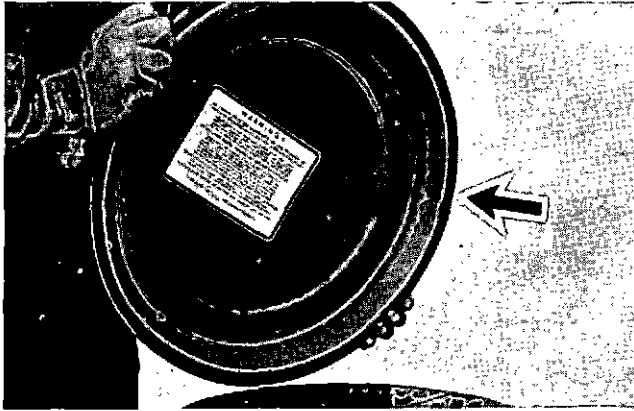

1. Remove the cover.

2. Remove the inner cover and filter element. In cold weather, a stuck inner cover may be removed by warming the air cleaner cover to 21-24°C (70-75°F).

3. Clean all parts of the air cleaner.

4. Inspect the replacement element for damage and cleanliness.

5. Install a clean undamaged element, inner cover, and wing nut. Tighten the wing nut.

6. Install the cover.

Cleaning Air Cleaner Elements

WARNING

When using pressure air, wear face shield and protective clothing. Maximum air pressure for cleaning purposes must be 205 kPa (30 psi).

CAUTION

When cleaning with pressure water, use 280 kPa (40 psi) maximum pressure to prevent element damage.

CAUTION

Do not clean elements by bumping or tapping them on hard objects.

Inspect an element after cleaning. Do not use an element with damaged pleats, gaskets or seals.

Have spare elements on hand to use when cleaning used ones.

Dry type air cleaner elements can be cleaned with either pressure air, water or detergent.

Pressure Air - 205 kPa (30 psi) Maximum

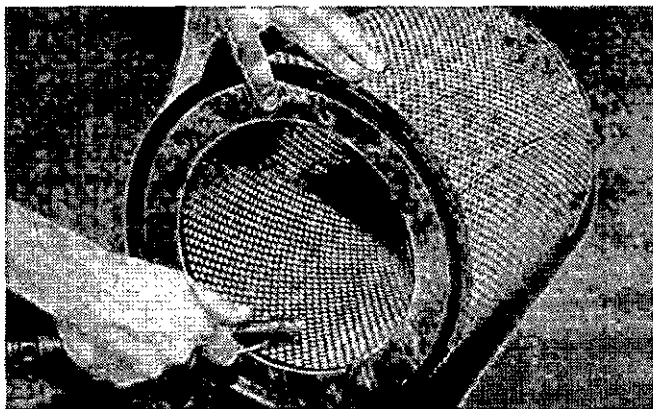

1. Direct air inside along length of pleats.

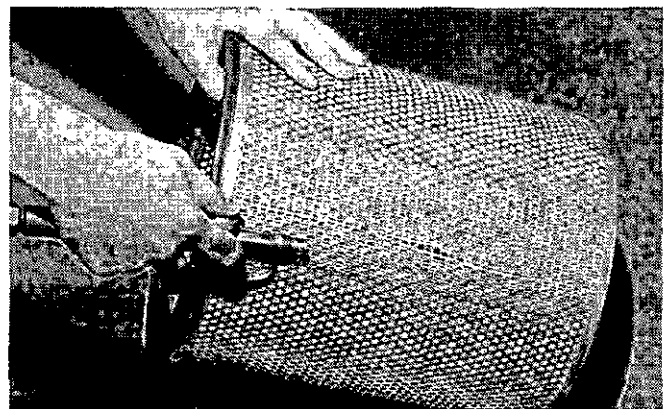

2. Direct air outside along length of pleats. Direct air inside along length of pleats. Inspect.

When Required

Water - 280 kPa (40 psi) Maximum

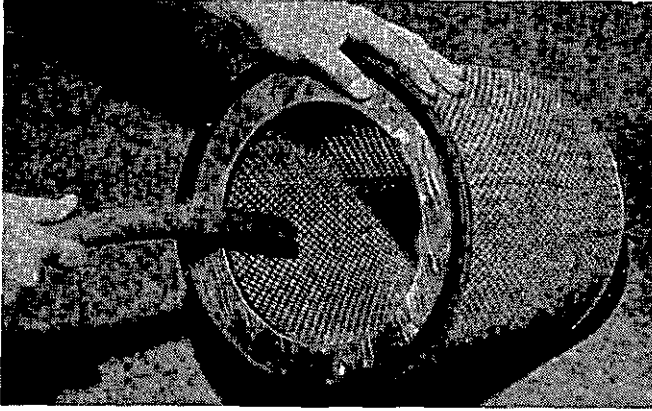

1. Direct water inside along length of pleats.

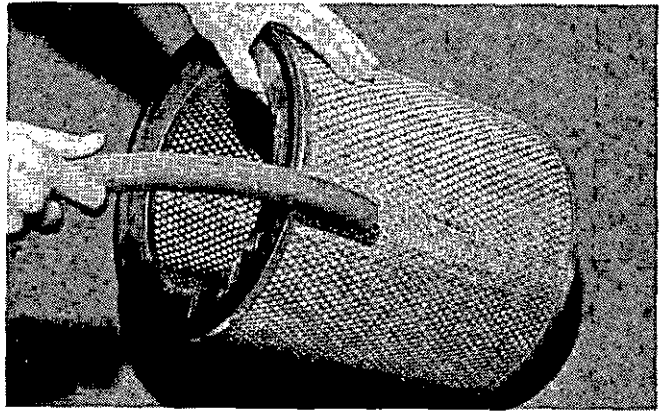

2. Direct water outside along length of pleats. Air dry and inspect the element.

Detergent

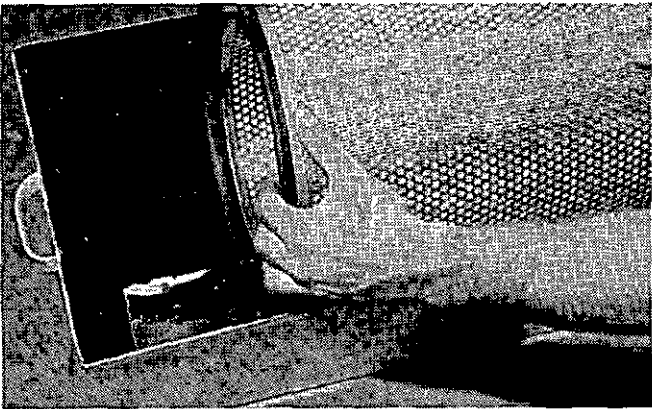

1. Wash in warm water and nonsudsing household detergent.

2. Rinse with clean water.

3. Air dry and inspect.

Inspecting Elements

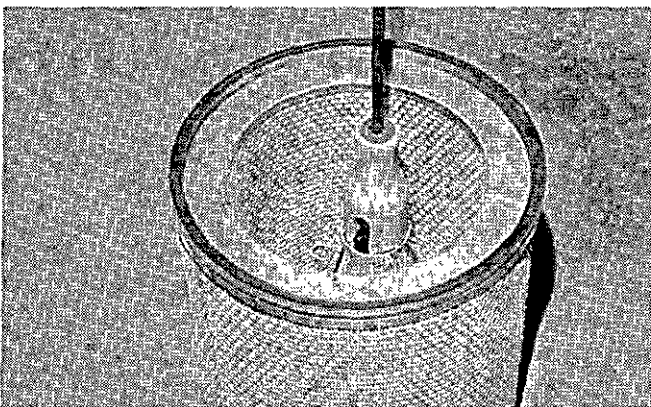

1. Insert a light inside a clean and dry element. Discard element if rips or tears are found.

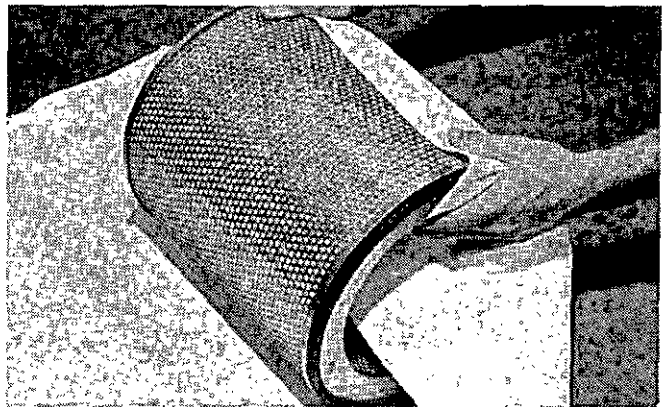

2. Wrap and store good elements in a clean dry place.

Fuel System — Sleeve Metering System

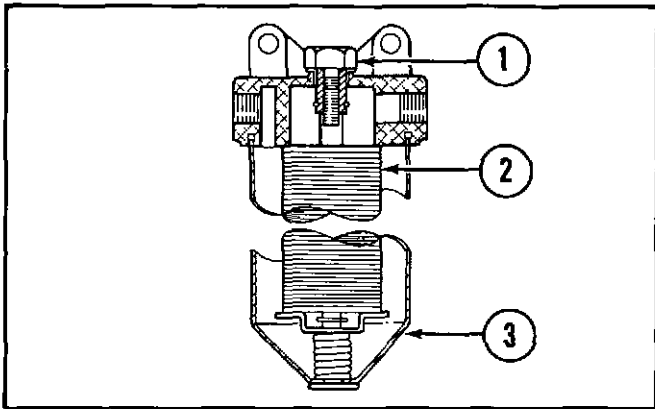

1. Stop the engine.
2. Shut off the fuel tank supply valve.
3. Loosen the nut (1) on the filter cover and lower the filter case (3).
4. Remove the element (2). Wash the cover and element in clean nonflammable solvent.
5. Reinstall the element.

Final Fuel Filters

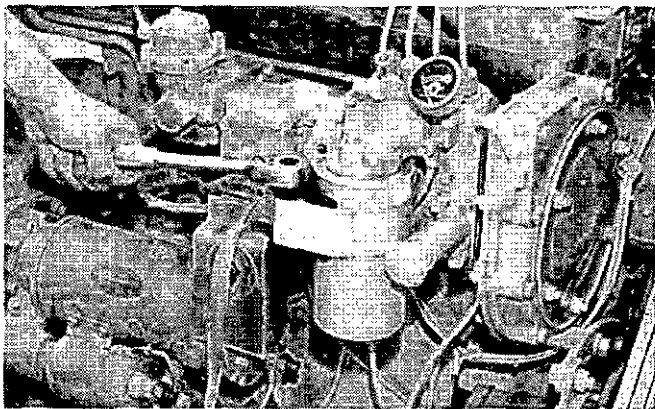

1. Remove and discard the filter (right hand thread).

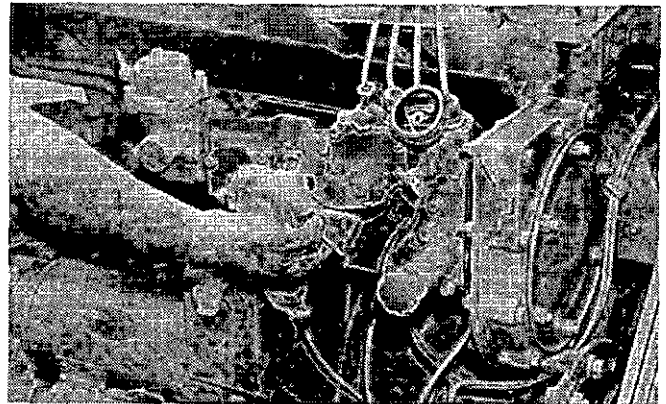

2. Clean the gasket sealing surface of the filter base.

CAUTION

Be sure all of old gasket is removed.

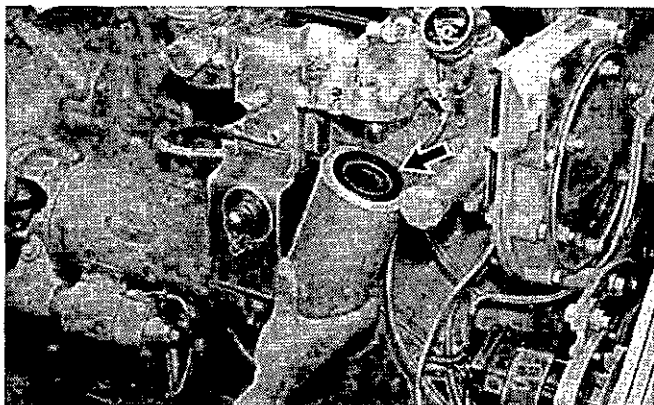

3. Lubricate the gasket of the new filter with clean fuel.

CAUTION

Do not pour fuel into the new filter element before installing. Prime the system as instructed in the topic, "To Prime the Fuel System."

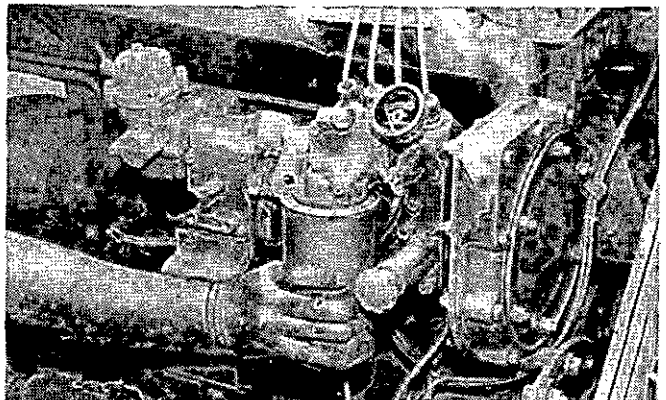

4. Install the filter and tighten it by hand until gasket contacts base, then tighten 1/2 to 3/4 turn more.
5. Prime the fuel system.

When Required

To Prime the Fuel System:

1. Move the governor control to the OFF position.

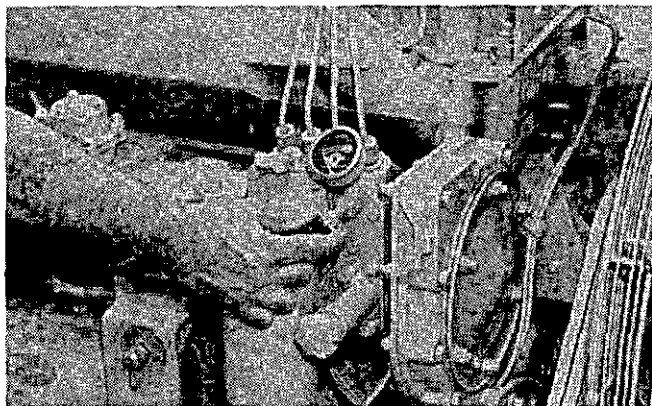

2. Open the vent valve on the fuel injection pump housing.

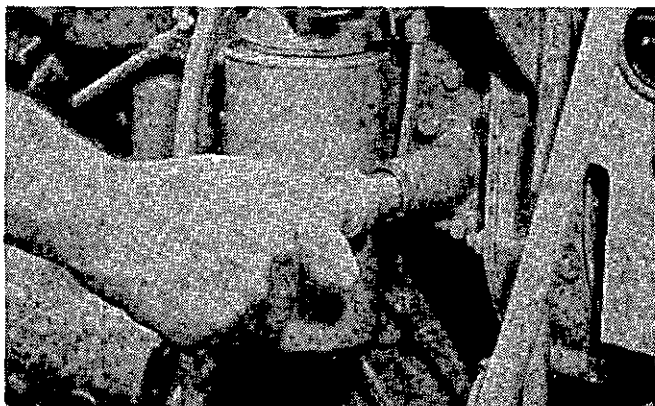

3. Operate the priming pump until the flow of fuel from the vent valve is continuous, and free of air bubbles.

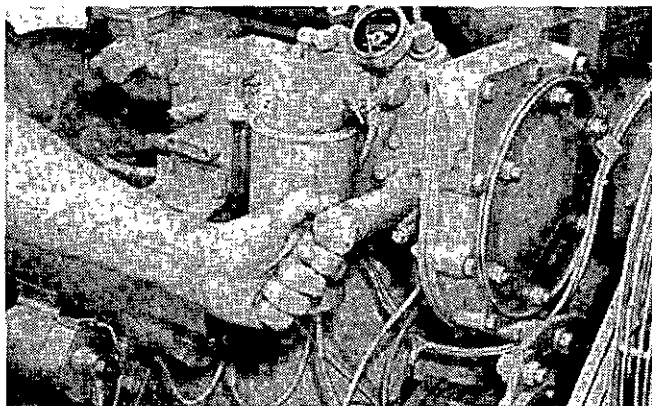

4. Close the vent valve and lock the fuel priming pump.

5. Start the engine. If the engine continues to misfire or smoke, further bleeding is necessary.

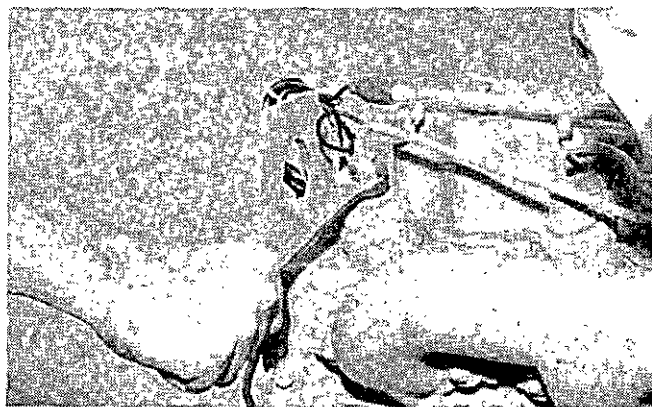

6. Loosen the fuel lines at the cylinder head. Crank the engine until fuel flows free of air bubbles.

7. Tighten the fuel line nuts to 30 ± 5 lb ft (40 ± 7 N.m).

Fuel System — New Scroll Fuel System

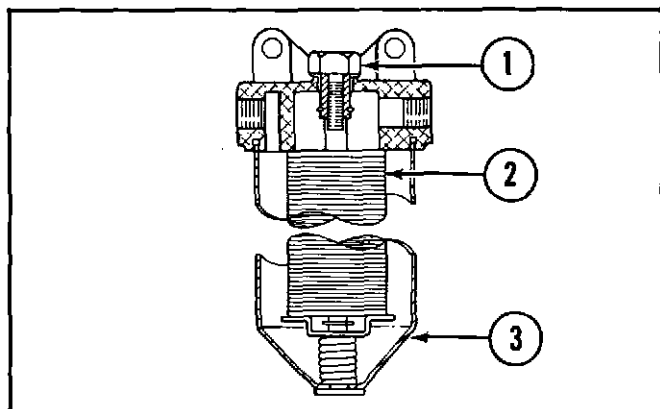

1. Stop the engine.
2. Shut off the fuel tank supply valve.
3. Loosen the nut (1) on the filter cover and lower the filter case (3).
4. Remove the element (2). Wash the cover and element in clean nonflammable solvent.
5. Reinstall the element.

Final Fuel Filters

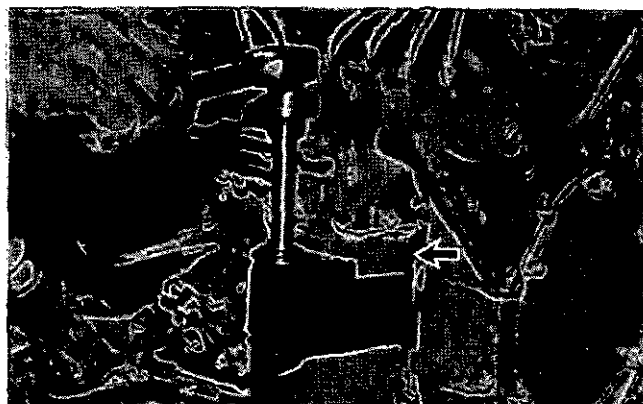

1. Remove and discard the filter (right hand thread).



2. Clean the gasket sealing surface of the filter base.

CAUTION

Be sure all of old gasket is removed.

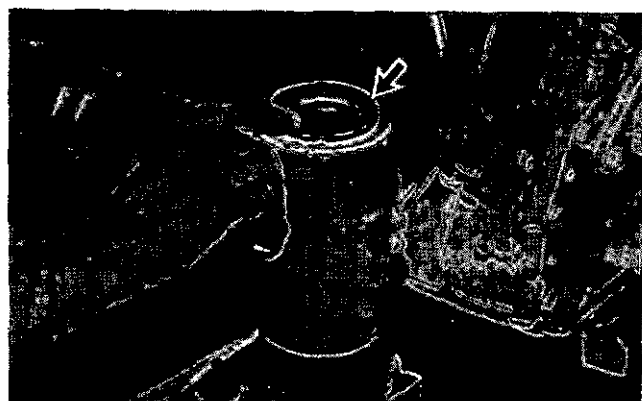

3. Lubricate the gasket of the new filter with clean fuel.

CAUTION

Do not pour fuel into the new filter element before installing. Prime the system as instructed in the topic, "To Prime the Fuel System."



4. Install the filter and tighten it by hand until gasket contacts base, then tighten 1/2 to 3/4 turn more.
5. Prime the fuel system.

When Required

To Prime the Fuel System:

1. Move the governor control to the OFF position.



2. Open the vent valve on the fuel injection pump housing.

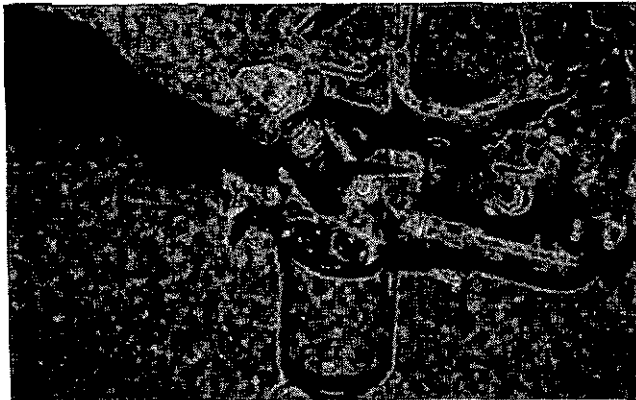

3. Operate the priming pump until the flow of fuel from the vent valve is continuous, and free of air bubbles.

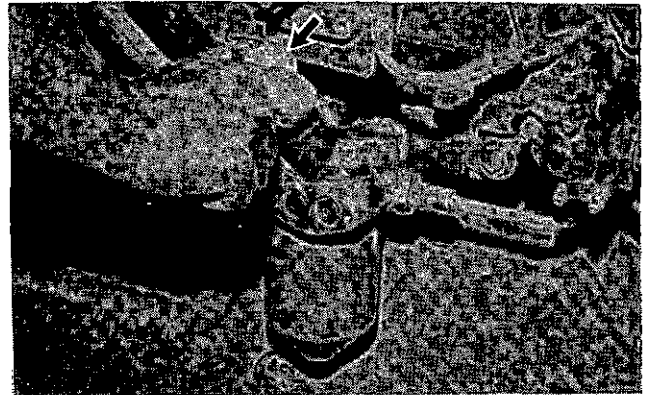

4. Close the vent valve and lock the fuel priming pump.

CAUTION

The fuel injection nozzles can be permanently damaged by twisting if only one wrench is used to loosen or tighten the fuel line nuts. Use one wrench to hold the nozzle and another to loosen the nut.

5. Start the engine. If the engine continues to misfire or smoke, further bleeding is necessary.

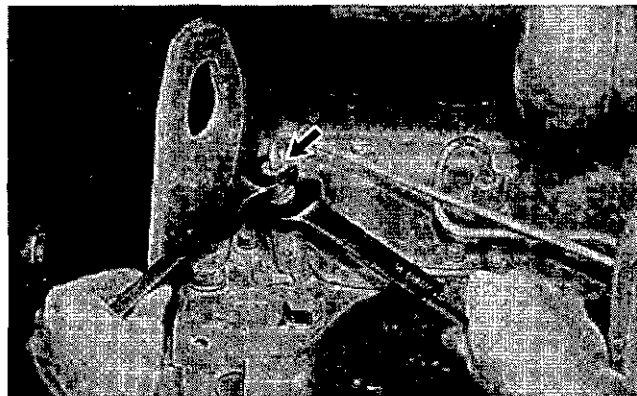

6. Loosen the fuel lines at the cylinder head. Crank the engine until fuel flows free of air bubbles.

7. Tighten the fuel line nuts to 30 ± 5 lb ft (40 ± 7 N.m).

Air Starter

Filling Motor Oiler

The vanes of the starting motor are lubricated with a fine oil mist from the motor oiler while the motor is operating.

When the oiler jar becomes half empty, remove the oil filler plug and fill the jar with clean oil. Refer to the Lubrication and Maintenance Chart for proper oil.

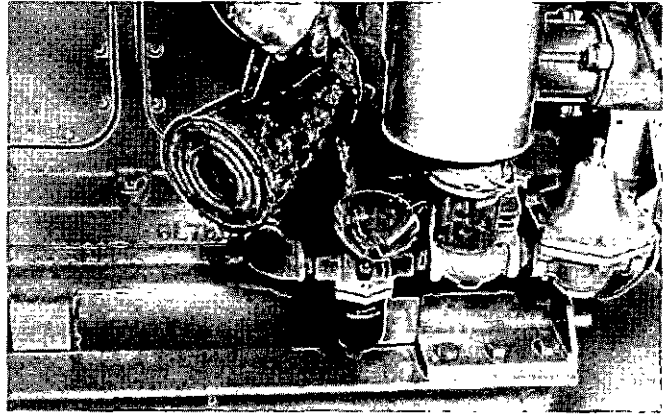

CAUTION

Never allow the jar to become empty. The starting motor will be damaged by lack of proper lubrication.

Emptying Oil Collector Jar

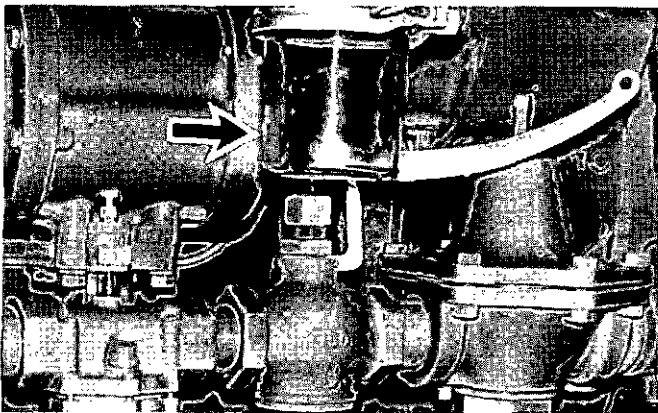

The collector jar collects both the oil after it has lubricated the starting motor vanes, and the moisture condensation from the compressed air.

Empty the collector jar whenever the jar becomes half full.

Adjusting Oiler Feed

If necessary, adjust the oiler to release approximately four drops of oil per minute into the starting motor air stream.

1. Be sure the fuel supply to the engine is turned OFF.
2. Pull up on the air start control lever and crank the engine.
3. Count the drops of oil released per minute into the air stream.
 - a. Turn the valve needle (the uppermost knob is the oiler) counterclockwise to increase the number of drops per minute.
 - b. Turn the valve needle clockwise to decrease the number of drops per minute.

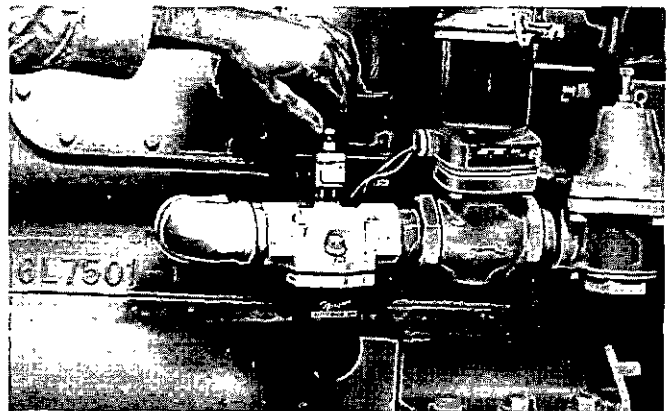

When Required

Batteries - Cleaning

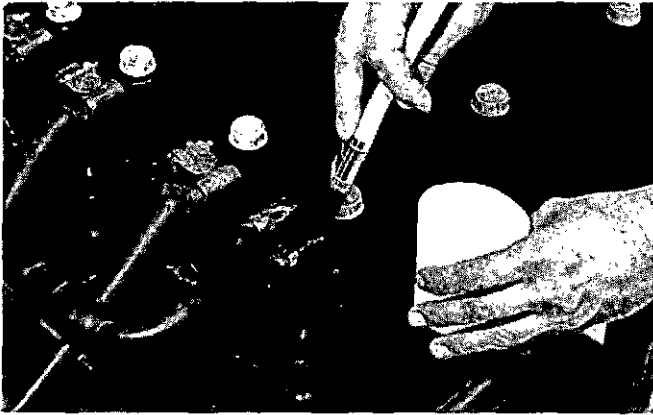

1. Loosen and remove cable clamps from all battery terminals.
2. Clean all battery terminals.
3. Clean all cable clamps.
4. Install and tighten cable clamps to battery terminals.
5. Coat cable clamps and terminals with grease.

Glow Plugs - Testing

1. Disconnect the wire lead from the glow plug terminal on the HEAT-START switch.
2. Install an ammeter with a capacity of over 75 amps, in a series, between the disconnected lead and the terminal on the HEAT-START switch.
3. Turn HEAT-START switch to HEAT.
4. Observe the ammeter. Each 12 volt glow plug draws approximately 12.5 amperes and each 24 volt glow plug draws approximately 6.5 amperes. The ampere draw of one glow plug multiplied by the number of engine cylinders will be the total

ampere draw of the glow plugs in the engine. A low reading indicates one or more defective glow plugs.

5. If a defective glow plug is indicated, disconnect one glow plug lead at a time.
6. Turn switch to the HEAT position. Observe the ammeter. Reconnect the lead.
7. The glow plug that does not change the reading on the ammeter, when the switch is turned on, is the defective glow plug.

Installing Glow Plugs

1. Disconnect the lead wire at the defective glow plug.
2. Remove the defective glow plug.
3. Apply anti-seize compound to the threads of the new glow plug.
4. Install the new glow plug and tighten to a torque of 45 to 53 N (10 to 12 pounds feet).
5. Turn the HEAT-START switch to the HEAT position and observe the ammeter reading.

6. Release the switch.
7. Install the lead wire.
8. Turn the HEAT-START switch to the HEAT position. The reading should be increased. If the reading is the same, check the glow plug wiring.
9. Disconnect the test ammeter.

Clutch - Adjustment

The clutch should engage with a hard push and a distinct snap. If the engagement is "soft", adjust the clutch.

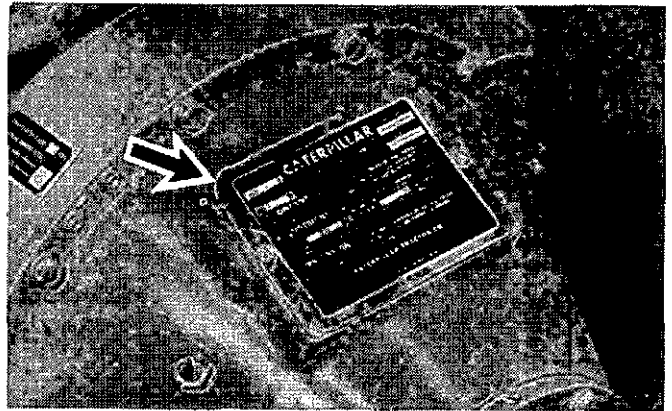

1. Stop the engine and remove the clutch inspection cover.



2. Turn the clutch until the lock pin, engaged in the locking ring, is visible.

3. Pull the lock pin out and rotate the locking ring clockwise until the lockpin pops into the next notch.

4. Test the clutch adjustment. If still too "soft", rotate the ring to the next notch. If the adjustment is too tight - turn the ring back one notch.

5. Install the cover.

Every 10 Service Hours

① Engine Crankcase

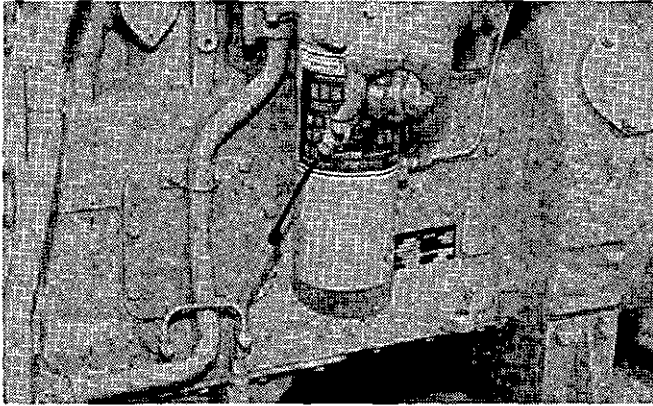

1. Measure oil level. Oil should be between the FULL and ADD marks on the "Running" side of the dipstick.

2. Add oil if necessary.

② Air Cleaner Indicator

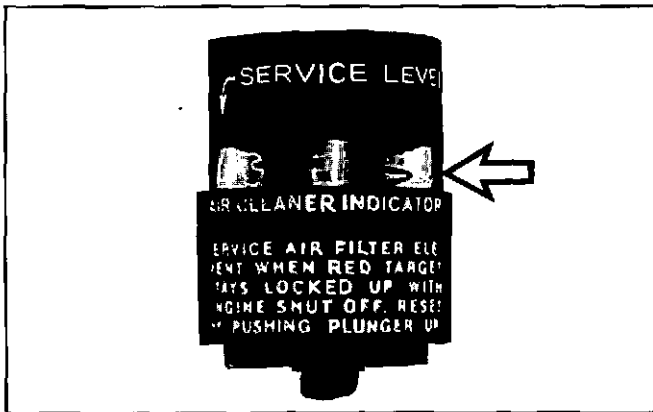

Inspect the air cleaner indicator. If the red piston is locked in the raised position, service the air cleaner.

③ Fuel Tank

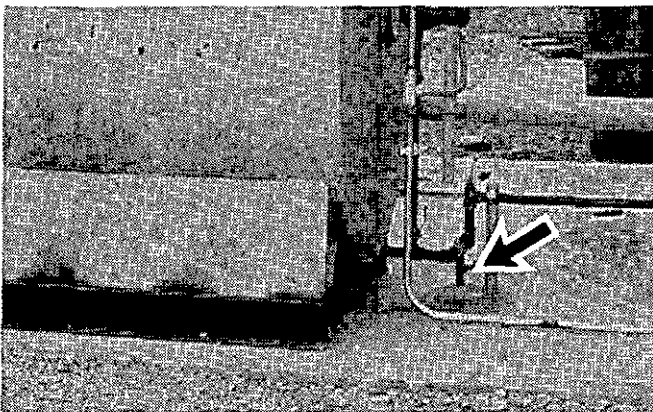

Drain water and sediment.

④ Water Separator—Drain

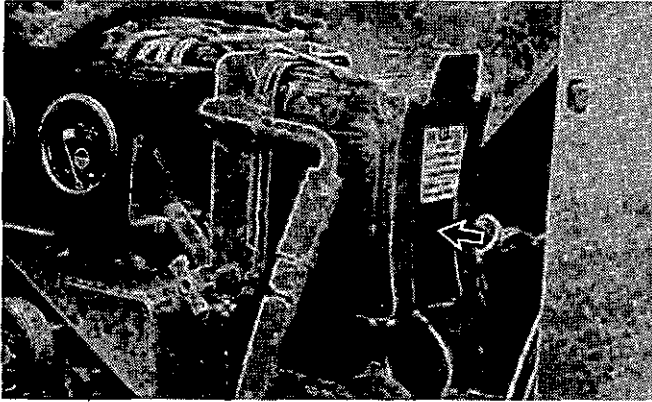

CAUTION

The engine should never be allowed to run with the water level in the element more than 1/2 full or engine damage may result.

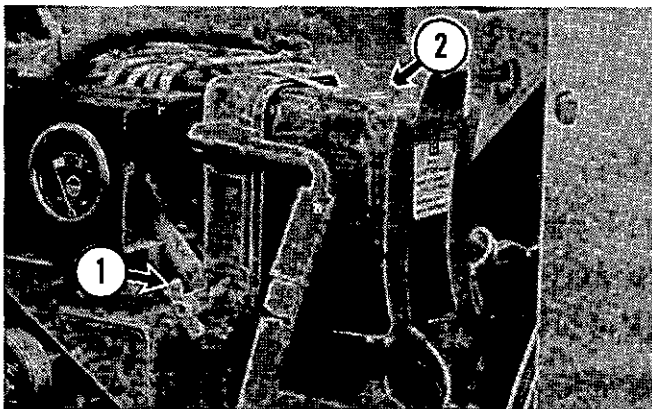

1. Close the fuel supply valve, if equipped.
2. Open the separator drain valve ①.
3. Open the separator vent valve ②.
4. After water is drained, close the vent valve and drain valve, and then open the fuel supply line valve.

Replace Element

Change element anytime water separator becomes contaminated enough that water level cannot be seen through the transparent cover.

1. Shut off the engine and close the fuel supply valve, if equipped.
2. Clean all dirt from the separator and surrounding area.

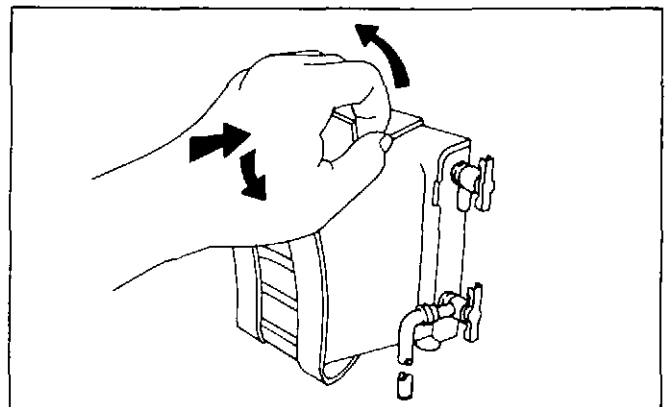

3. To remove the element, depress the extended tab with the heel of the hand. Then lift the slotted tab from the locking slot, at the top of the base, with the fingers.
4. Pull the old element from the base and discard it.

Every 10 Service Hours

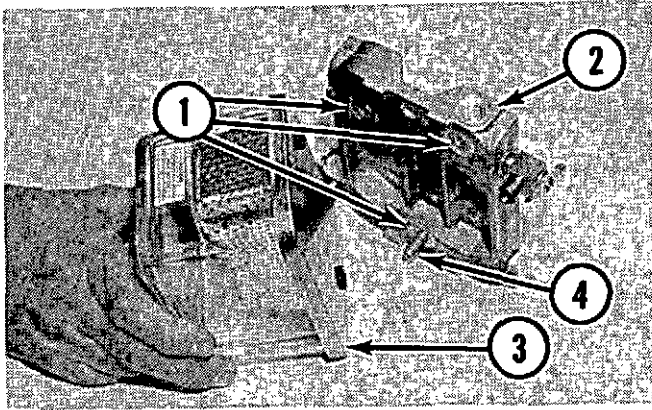

5. Clean the three sealing surfaces ① on the base ② with a clean cloth.

6. Install the new element ③ to the base by first inserting the roll pin ④ into the outlet passage at the bottom of the base. Align the filter holes with the base holes, and push the element into place.

7. Place the lower tab of the clamp in the bottom locking slot of the base. Push the upper tab into the locking slot at the top of the base. Make sure clamp is securely engaged in the top and bottom locking slots.

8. Open the fuel valve and start the engine. It may be necessary to prime the fuel system if the engine does not start. Inspect for fuel leaks.

⑤ Cooling System—Check Coolant Level

⚠ WARNING

At Operating Temperature, engine coolant is hot and under pressure.

Steam can cause personal injury.

Check coolant level **ONLY** when engine is stopped and filler cap is cool enough to touch with your hand.

Remove filler cap slowly to relieve pressure.

Cooling System Conditioner contains alkali. Avoid contact with skin and eyes to prevent personal injury.

If it is necessary to add coolant daily, inspect the cooling system for leaks.

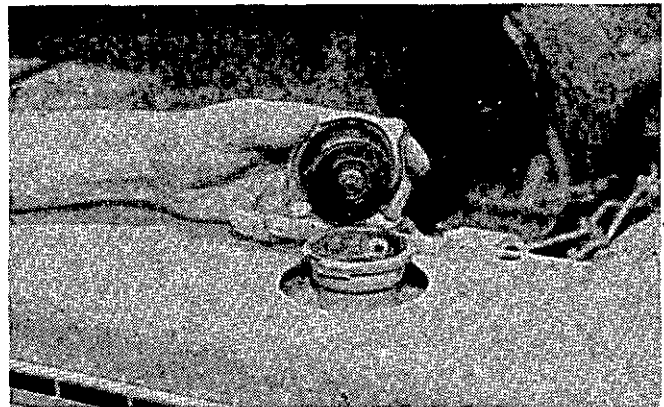

1. Inspect coolant level with the engine stopped and cold. Remove the radiator cap slowly to relieve pressure. Observe the coolant level.

2. Maintain coolant level within 1 cm (1/2 inch) below the top of the fill pipe. Inspect cap gasket and replace if necessary.

⑥ Clutch Shift Collar

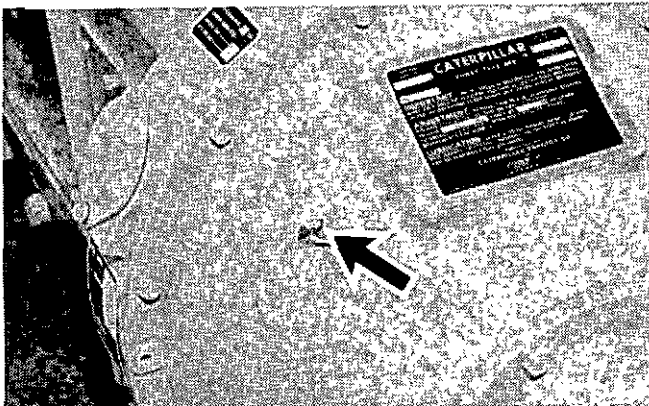

Lubricate 1 fitting.

Every 50 Service Hours

7 Dust Collector Cup—Clean



1. Remove the retaining wing nut from the top of the dust collector cup.



2. Remove and clean the dust collector cup.

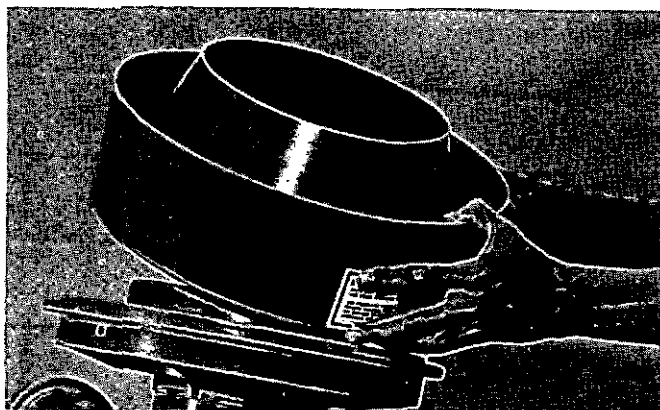

3. Install the dust collector cup.

8 Batteries—Check Electrolyte Level

WARNING

Do not smoke when observing battery electrolyte level. Batteries give off fumes that can explode.

Electrolyte is an acid and can cause personal injury if it contacts skin or eyes.

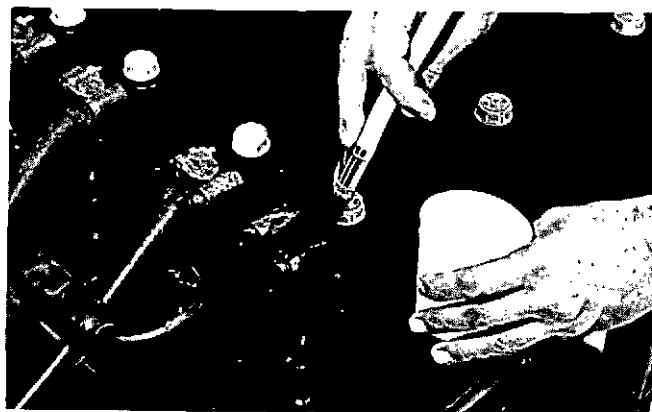

1. Clean the tops of the batteries. Keep the terminals clean and covered with a light coat of grease.

Every 50 Service Hours



2. Remove all fill caps. Observe the electrolyte level.

3. Maintain the electrolyte level to the bottom of the filler openings.

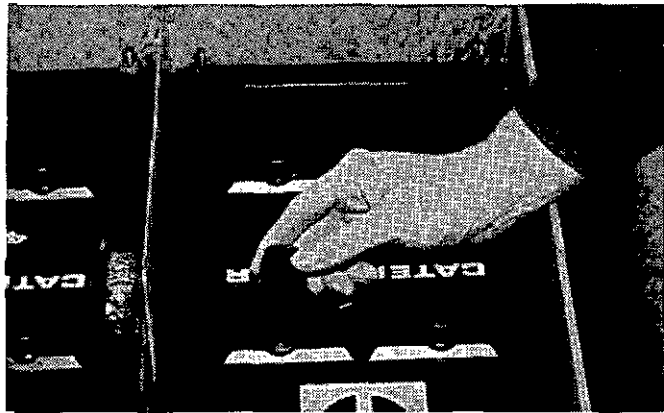

4. Install the fill caps.

If water is necessary, use distilled water if it is available. Otherwise, use clean water that is low in minerals. Do not use artificially softened water.

Every 125 Service Hours

9 Clutch Control Lever

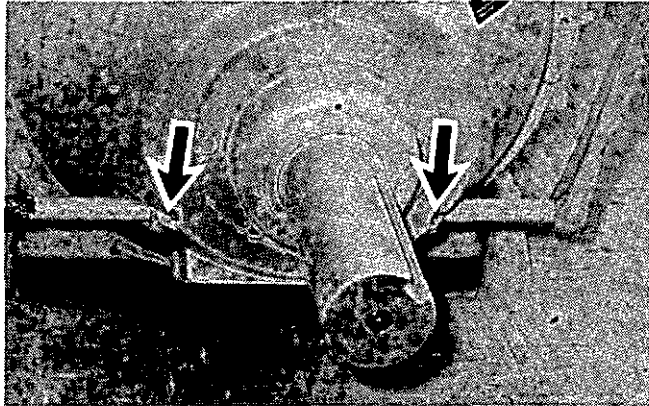

Lubricate 2 fittings; 1 fitting on each side of the clutch housing.

10 Clutch Pilot Bearing

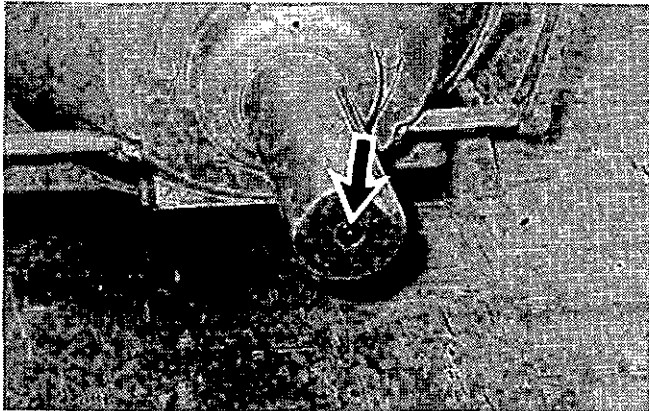

Lubricate 1 fitting at the end of shaft.

11 Clutch Main Shaft Bearing

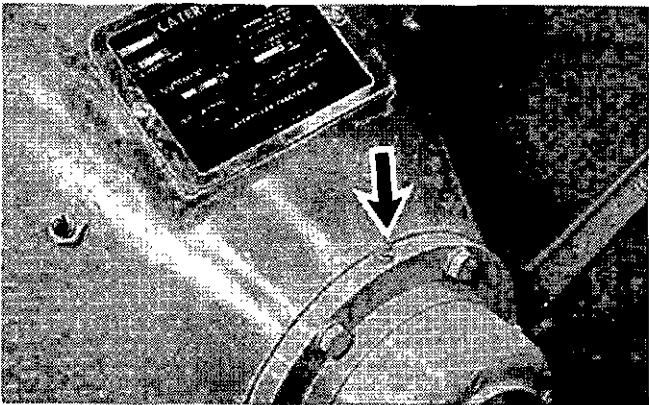

Lubricate 1 fitting on top-rear of housing.

Every 250 Service Hours

⑫ Alternator Belts

1. Check the belts for excessive wear, fraying and cracking.

When belt replacement is necessary, belts must be replaced in complete matched sets. Never replace only one belt. The new belt will carry all the load and fail rapidly.

2. Apply a 110 N (25 pound) force perpendicular to the belt, midway between the driving and driven pulley. Measure the belt deflection.

Proper belt deflection is 14 to 20 mm (9/16 to 13/16"). Adjust the belt tension as required.

To Adjust:

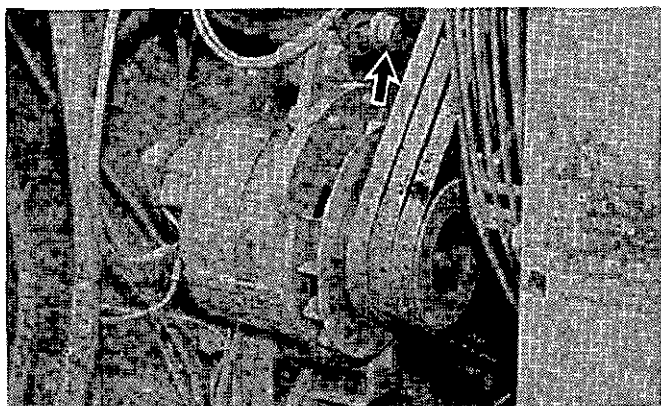

1. Loosen the anchor bolt in the slotted bracket.

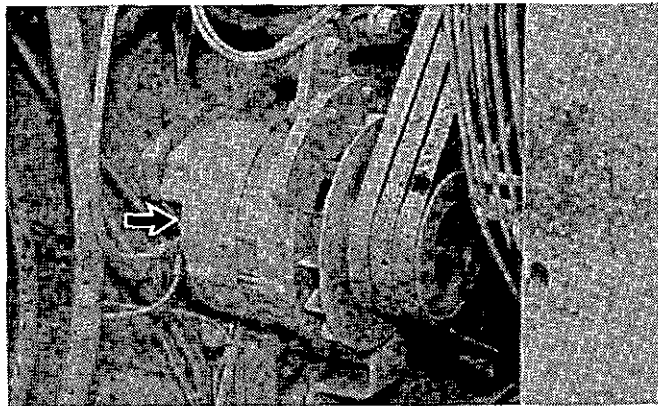

2. Move the alternator in or out to obtain proper adjustment.

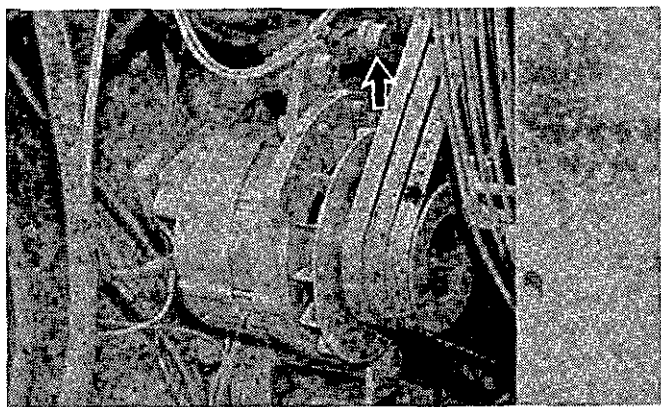

3. Tighten the anchor bolt after the belt is properly adjusted.

13 Engine Crankcase—Change Oil and Filter (Turbocharged)

⚠ WARNING

Use caution when draining oil or changing filters. Hot oil or components can cause burns if they contact skin.

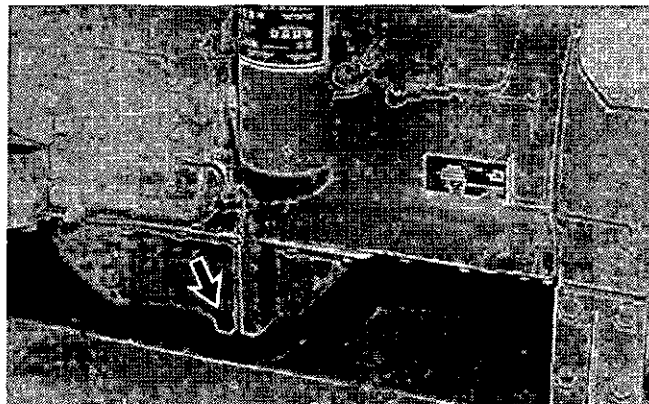

Engine stopped and the oil warm.

1. Remove the crankcase oil drain plug, and allow the oil to drain.

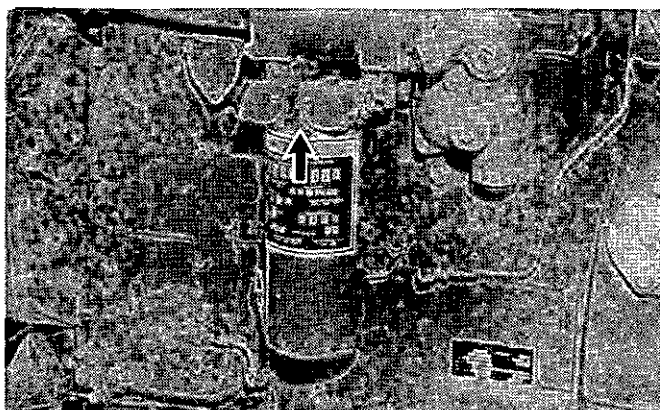

2. Wipe the dirt from the oil filter housing.

3. Remove and discard the filter.



4. Clean the filter base. Make sure all of old gasket is removed.

5. Install the new filter. Hand tighten the filter an additional $3/4$ turn after the gasket contacts the base.

The filter may have index marks spaced 90° apart. These marks should be used when tightening the new filter an additional $3/4$ turn.

Every 250 Service Hours

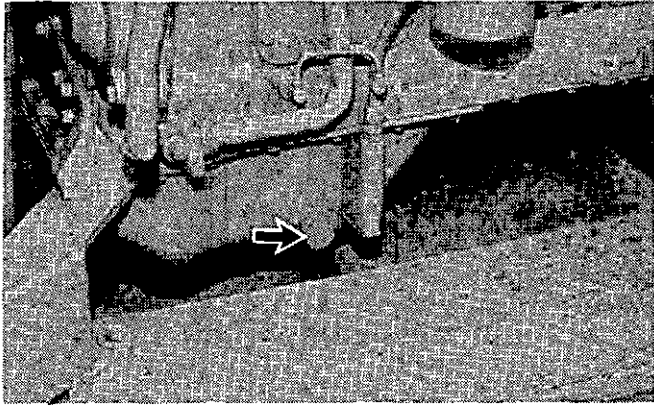

6. Clean the drain plug in clean nonflammable solvent and install it.

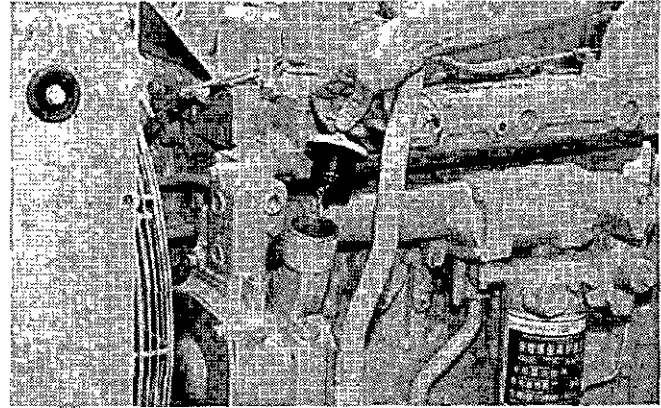

7. Fill the crankcase. See "Refill Capacities."

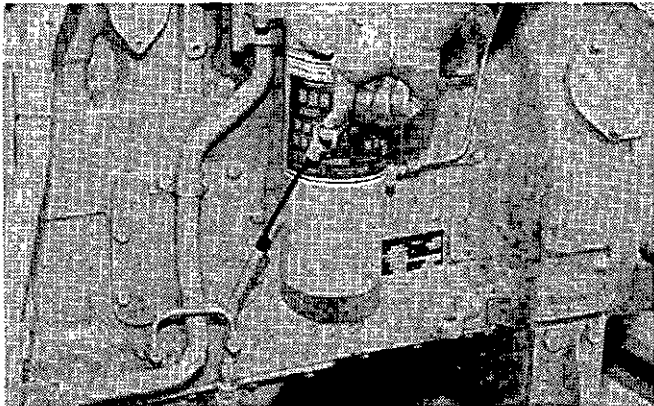

8. Crank the engine with the throttle in the FUEL OFF position until oil pressure is indicated on the pressure gauge. Then move the throttle to the FUEL ON position and start the engine.

9. Stop the Engine. Maintain level to FULL mark.

Crankcase Breather

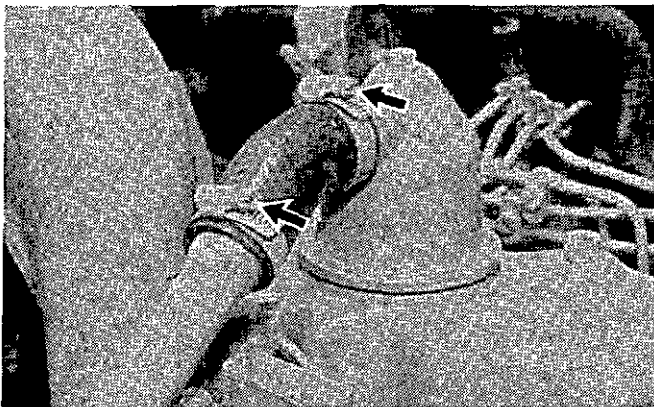

1. Release the fumes disposal hose clamps at the breather and disconnect the hose.

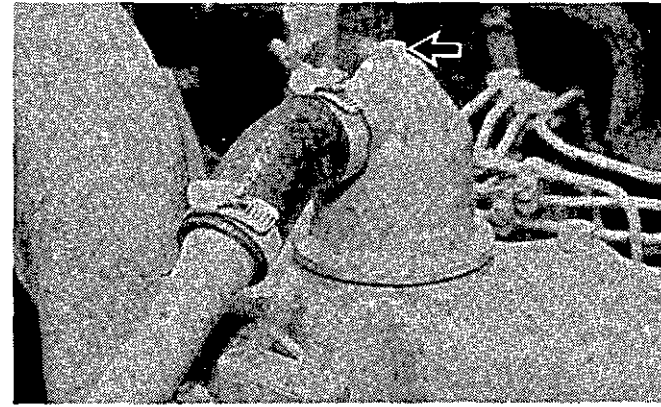

2. Loosen the breather retaining bolt and remove the breather.

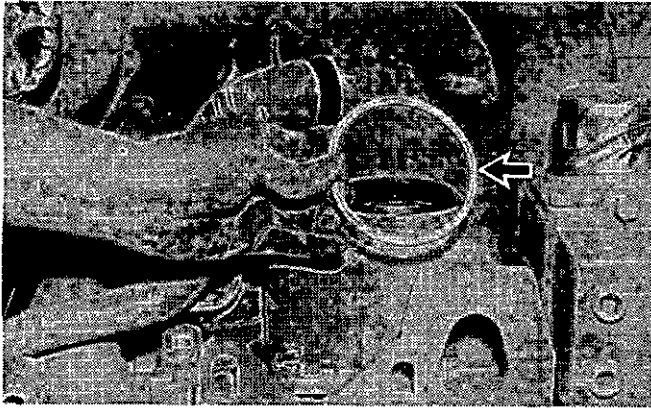

3. Inspect the gasket. Replace if necessary.
4. Clean the breather in clean nonflammable solvent. Allow to dry.
5. Install the breather.
6. Install the fumes disposal tube hose and clamps on the breather.

⑭ Cooling System - Add Cooling System Conditioner

⚠ WARNING

At Operating Temperature, engine coolant is hot and under pressure.

Steam can cause personal injury.

Check coolant level **ONLY** when engine is stopped and radiator cap is cool enough to touch with your hand.

Remove filler cap slowly to relieve pressure.

Cooling System Conditioner contains alkali. Avoid contact with skin and eyes to prevent personal injury.

CAUTION

Do not use Caterpillar Cooling System Conditioner with Dowtherm 209 Full-Fill Coolant.

CAUTION

Add conditioner if the engine has actually operated 250 Service Hours. Adding conditioner before 250 Service Hours will result in an excessive concentration of conditioner.

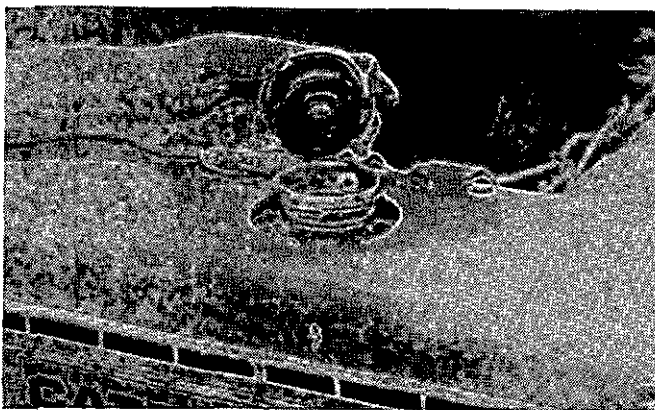

1. Loosen filler cap slowly to relieve pressure, and remove filler cap.

It may be necessary to drain enough coolant to allow for the addition of cooling system conditioner.

2. Add Caterpillar Cooling System Conditioner to the cooling system. See "Coolant Specifications" under the topic "Lubricants, Fuels and Coolants," for the proper concentration of conditioner.

Most systems will require 2 liters (2 quarts) of conditioner at initial fill and .50 liters (1 pint) "Every 250 Service Hours."

3. Inspect filler cap gasket. Replace if damaged.

4. Install filler cap.

Every 500 Service Hours

⑮ Engine Crankcase (N. A. Engine)—Change Oil and filter

Change oil, filter and clean breather. See Item (13) for details.

⑯ Fan Bearing

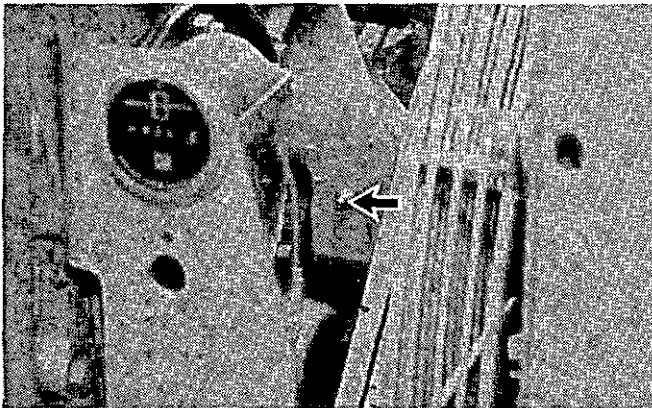

Lubricate 1 fitting.

⑯ Fuel System

Sleeve Metering System

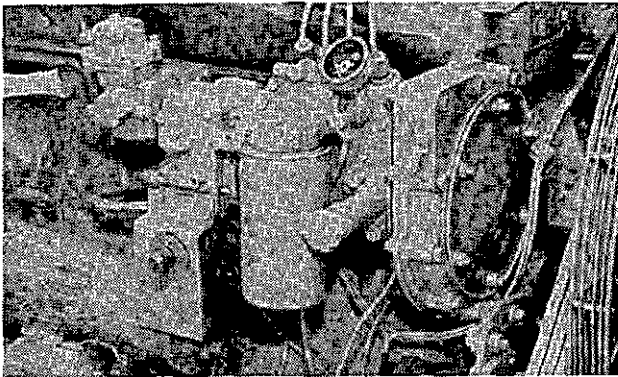

New Scroll Fuel System

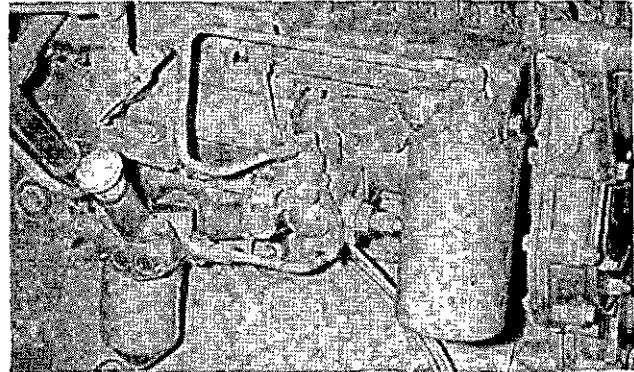

The primary fuel filter should be cleaned and the final fuel filter element replaced every 500 service hours of operation or when the fuel gauge registers "OUT" with the engine running. Refer to "Fuel System" in "When Required" section for procedure to change the fuel filters.

Every 1000 Service Hours

17 Woodward PSG Governor



Lubricate 2 fittings.

Synchronizing Motor

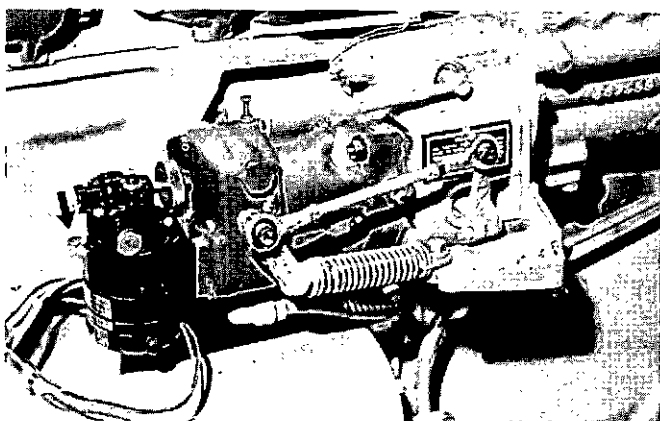

Fill oil cup.

18 Shutoff Controls

The shutoff controls must be checked periodically so that they will function properly, when required. To prevent damage to the engine while making the required test, only authorized personnel should perform the checks. Contact your Caterpillar dealer.

19 Tachometer Drive

Lubricate 1 fitting.

Every 2000 Service Hours

20 Engine Valve Lash

3306

3304

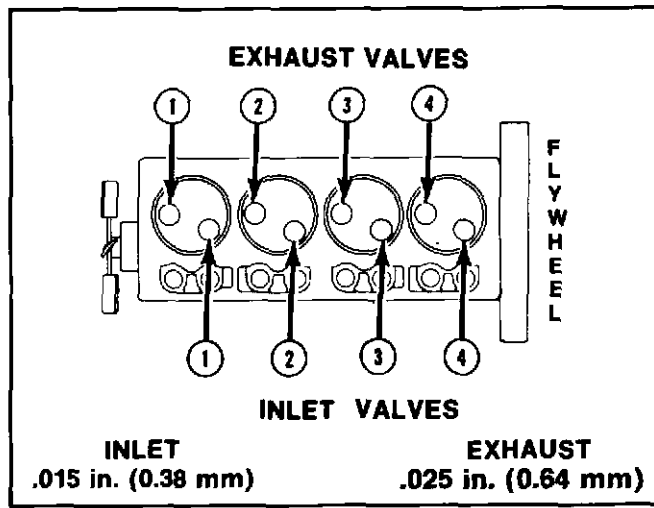
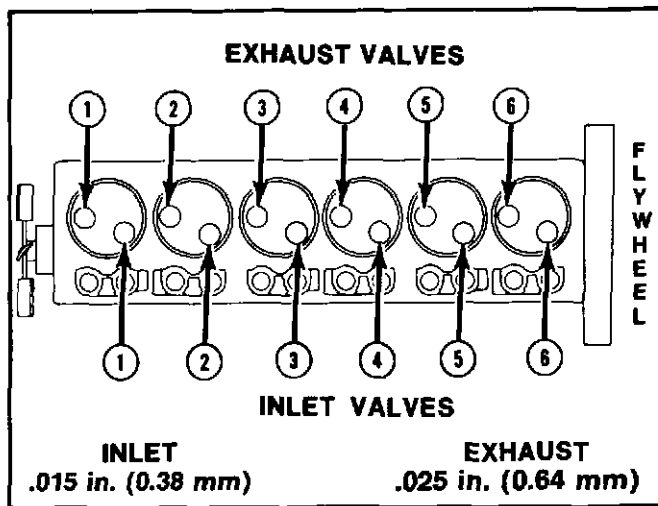

If valve clearance is within $\pm .003$ inch (0.07 mm) of the clearance given, adjustment is not required. If clearance is not within these limits, adjust the valves.

Adjust valves with the engine stopped and cold.

To Inspect Valve Lash

1. Stop engine.
2. Clean the base of the valve cover to prevent dirt from getting into valve mechanism.

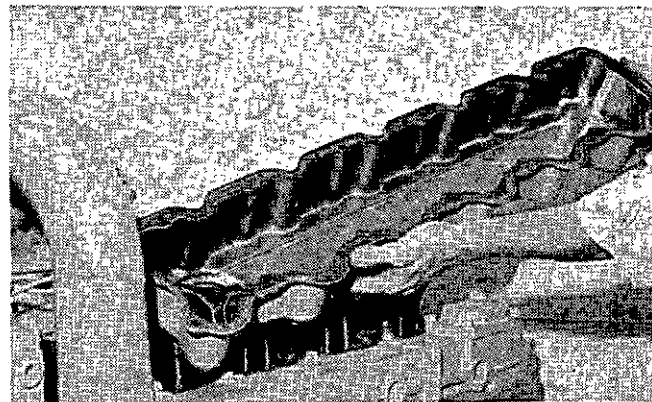

3. Remove the valve cover.



4. Remove the flywheel housing timing plug.

A flywheel Engine Turning Tool 5P7307, is available from your Caterpillar dealer. Consult your Caterpillar dealer for proper instructions for use of the tool.

5. Turn the flywheel to close No. 1 exhaust and inlet valves, aligning plug hole in the flywheel housing with the hole in the flywheel. The engine is now on Number 1 Top Center Compression Stroke.



6. Install a 63.5 mm (2 1/2 inch) long 9.40 mm (3/8 inch) NC bolt into the flywheel, through the flywheel housing.

7. Measure the lash for the valves shown in the Compression Stroke Charts.

3306 COMPRESSION STROKE	
VALVES	CYLINDERS
INLET	1-2-4
EXHAUST	1-3-5

EXHAUST STROKE	
VALVES	CYLINDERS
INLET	3-5-6
EXHAUST	2-4-6

8. Remove the timing bolt from the flywheel.

9. Rotate the flywheel 360° and install the timing bolt in the flywheel.

10. Measure the lash for the valves shown in the Exhaust Stroke Charts.

11. Remove bolt from flywheel and install plug in flywheel housing.

12. Remove the engine turning group and install the starting motor.

3304 COMPRESSION STROKE	
VALVES	CYLINDERS
INLET	1-2
EXHAUST	1-3

EXHAUST STROKE	
VALVES	CYLINDERS
INLET	3-4
EXHAUST	2-4

Every 2000 Service Hours

To Adjust Valves

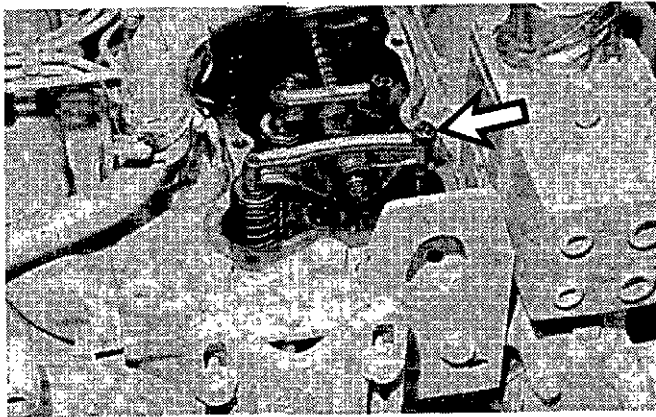

1. Loosen the locknut on the adjusting screw.

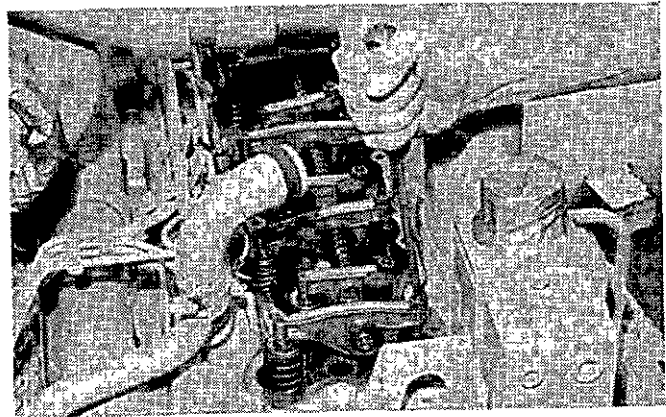

2. Turn the adjusting screw to obtain the proper valve lash.

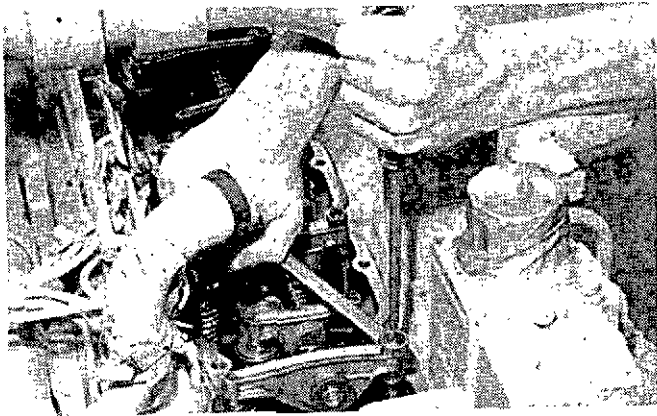

3. Hold the adjusting screw and tighten the locknut to 29 ± 7 N·m (21 ± 5 lb. ft.).

4. Measure the valve lash.

Observe Valve Rotation

After adjusting valve lash, and before installing the valve cover:

1. Start the engine and run at low idle.
2. Watch the valve rotocoils for rotation.

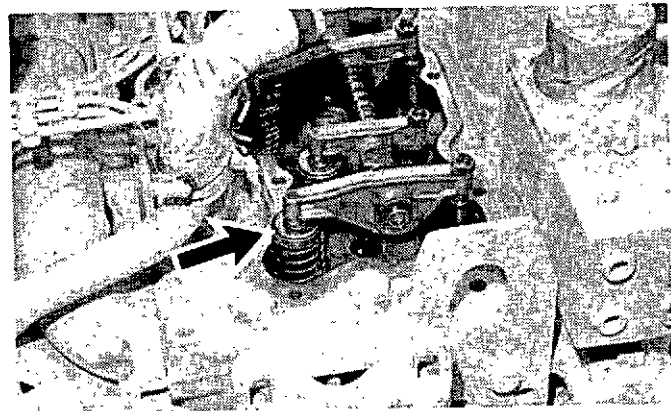

3. Each valve rotocoil should turn slightly each time the valve opens. If a valve fails to rotate, contact your Caterpillar dealer for service.

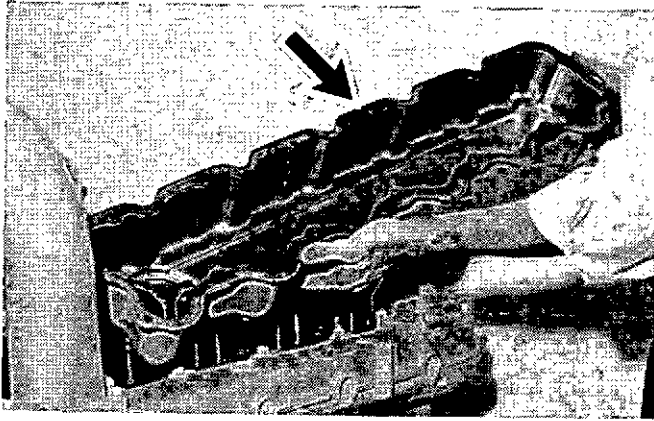

4. Stop the engine. Inspect the valve cover gasket. Use a new gasket if the used gasket is damaged.

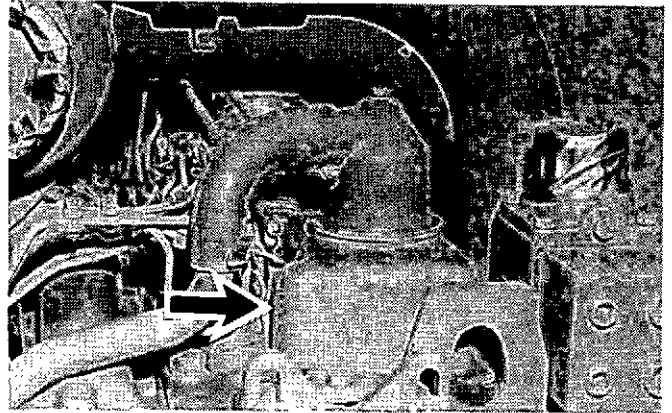

5. Install the valve cover. Tighten bolts to 11 ± 3 N-m (8 ± 2 lb. ft.).

Every 2000 Service Hours

21 Cooling System - Change Antifreeze Solution

⚠ WARNING

At Operating Temperature, engine coolant is hot and under pressure.

Steam can cause personal injury.

Check coolant level **ONLY** when engine is stopped and radiator cap is cool enough to touch with your hand.

Remove filler cap slowly to relieve pressure.

Cooling System Conditioner contains alkali. Avoid contact with skin and eyes to prevent personal injury.

CAUTION

All water is corrosive at engine operating temperature. Use either Caterpillar Cooling System Conditioner liquid, or the coolant conditioner element to treat either plain water or ethylene glycol antifreeze solution. **NEVER** use both the liquid cooling system conditioner and the coolant conditioner element at the same time.

When changing antifreeze solution, replace the attachment coolant conditioner group maintenance filter element with the appropriate precharge filter element.

Do not use Caterpillar Cooling System Conditioner or Coolant Conditioner Elements with Dowtherm 209 Full-Fill coolant.

Never add coolant to an overheated engine; allow the engine to cool first.

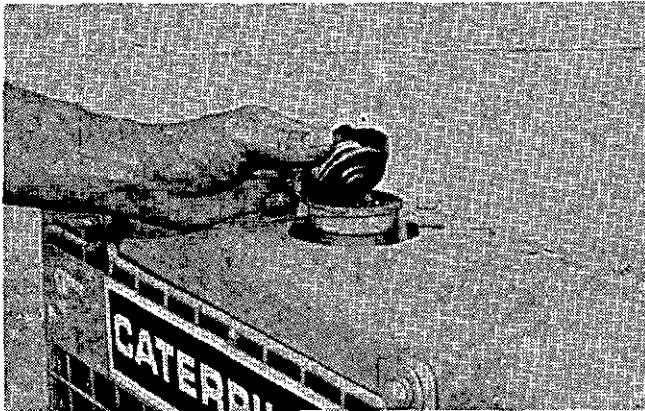

1. Loosen the radiator cap slowly to release pressure. Remove the radiator cap.

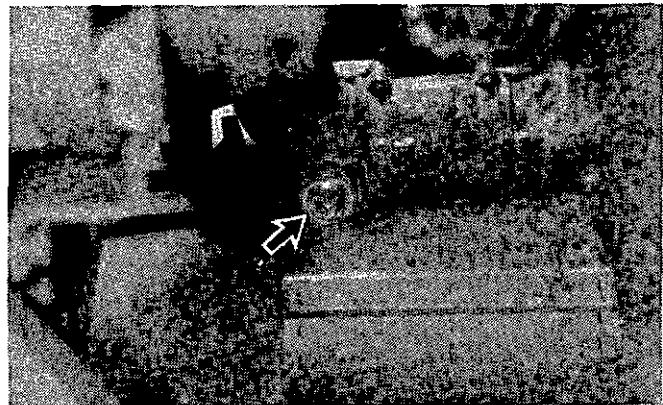

2. Remove the radiator drain plug. Allow the coolant to drain.

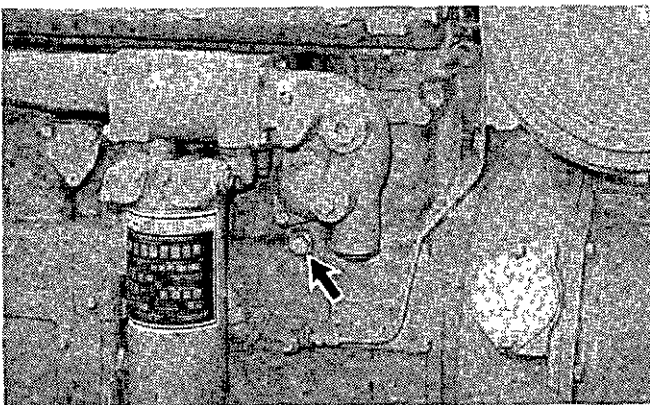

3. Remove engine block drain plugs. Allow coolant to drain.

4. Clean the drain plugs.

5. Install the drain plugs.

Filling the Cooling System

1. Mix antifreeze to provide protection to the lowest expected ambient temperature.

Do not fill cooling system to the top. Allow for addition of conditioner.

Most systems will require 2 liters (2 quarts) of conditioner at initial fill and .50 liters (1 pint) "Every 250 Service Hours."

2. To help avoid air pockets, add coolant slowly, at 5 U.S. gallons (19 liters) per minute or less. See REFILL CAPACITIES.

3. Add cooling system conditioner.

4. Bring the coolant level to within 1/2 inch (1 cm) of the bottom of the fill pipe.

5. Start the engine with the radiator cap off. Add coolant, if necessary, when level stabilizes.

6. Stop the engine. Replace the radiator cap seal if damaged. Install the radiator cap.

Effective with sales to the first user on or after March 1, 1988

Caterpillar Warranty

INDUSTRIAL, AGRICULTURAL, MARINE ENGINES AND MARINE TRANSMISSIONS, AND ELECTRIC POWER GENERATION PRODUCTS

Caterpillar warrants the following products sold by it for use in industrial, agricultural, marine, and electric power generation applications to be free from defects in material and workmanship:

- New, Remanufactured and Major Component Exchange (MCE) Engines.
- Marine Transmissions
- Electric Power Generation Products

This warranty does not apply to products sold for use in on-highway vehicles; machines manufactured by or for Caterpillar; products sold for use in personal, family, or household applications in the United States of America, its territories and possessions; 3500 and 3600 Family Engines used in locomotive applications, or 3114 and 3116 Engines, and marine transmissions and electric power generation products sold for use with such engines. Such products are covered by other Caterpillar warranties.

This warranty is subject to the following:

Warranty Period

The warranty period specified below is for whichever of the following occurs first after date of delivery to the first user.

- New engines used in industrial, agricultural, marine and electric power generation applications; and marine transmissions and electric power generation products: 12 months (24 months for mobile agricultural and standby electric power generation applications).
- Remanufactured 3200 Family Engines used in mobile agricultural and standby electric power generation applications: 12 months.
- Remanufactured Engines used in other applications and MCE engines used in any application: 6 months.

Caterpillar Responsibilities

If a defect in material or workmanship is found during the warranty period, Caterpillar will, during normal working hours and through a place of business of a Caterpillar dealer or other authorized source:

- Provide new, MCE, Remanufactured or Caterpillar-approved repaired parts or assembled components (at Caterpillar's choice) needed to correct the defect.

NOTE: Items replaced under this warranty become the property of Caterpillar.

- Provide reasonable and customary labor needed to correct the defect, including labor to disconnect the product from and reconnect the product to its attached equipment, mounting, and support systems, if required.
- Provide reasonable travel expenses for authorized mechanics, including meals, mileage and lodging when Caterpillar chooses to make the repair on-site.
- Replace lubricating oil, filters, antifreeze and other service items made unusable by the defect.

The User is responsible for:

User Responsibilities

- Labor costs, except as stated under "Caterpillar Responsibilities", including costs beyond those required to disconnect the product from and reconnect the product to its attached equipment, mounting and support systems.
- All costs for transporting the product or equipment in which the product is installed.
- Travel expenses not covered under "Caterpillar Responsibilities".
- Parts shipping charges in excess of those which are usual and customary.
- Local taxes, if applicable.
- Costs to investigate complaints, unless the problem is caused by a defect in Caterpillar material or workmanship.
- Giving timely notice of a warrantable failure and promptly making the product available for repair.

Continued on reverse side . . .

Limitations

Caterpillar is not responsible for failures resulting from:

- Any use or installation which Caterpillar judges improper.
- Attachments, accessory items and parts not sold nor approved by Caterpillar.
- Abuse, neglect and/or improper repair.
- User's unreasonable delay in making the product available after being notified of a potential product problem.

NEITHER THE FOREGOING EXPRESS WARRANTY NOR ANY OTHER WARRANTY BY CATERPILLAR, EXPRESS OR IMPLIED, IS APPLICABLE TO ANY ITEM CATERPILLAR SELLS, WHICH IS WARRANTED DIRECTLY TO THE USER BY ITS MANUFACTURER.

THIS WARRANTY IS EXPRESSLY IN LIEU OF ANY OTHER WARRANTIES, EXPRESS OR IMPLIED, INCLUDING ANY WARRANTY OF MERCHANTABILITY OR FITNESS FOR A PARTICULAR PURPOSE. REMEDIES UNDER THIS WARRANTY ARE LIMITED TO THE PROVISION OF MATERIAL AND SERVICES, AS SPECIFIED HEREIN. CATERPILLAR IS NOT RESPONSIBLE FOR INCIDENTAL OR CONSEQUENTIAL DAMAGES.

As Used in this warranty, the term "Caterpillar" means Caterpillar Inc. or its subsidiaries, except Caterpillar of Australia Ltd., whichever last sold the product involved.