

Chrysler

V-8 INDUSTRIAL ENGINES

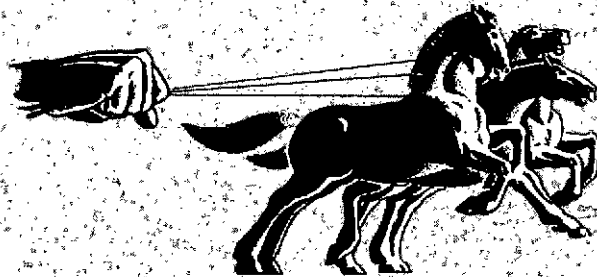

HORSEPOWER WITH A PEDIGREE!

MODEL
IND. 20A

OPERATING MANUAL

D-14054

Specifications

Make	Chrysler
Model	20A
Type	Overhead Valve
Arrangement	90 Degrees
Bore	3 13/16 in.
Stroke	3 5/8 in.
Piston Displacement	331 cu. in.
H. P. Rating	180 at 4000 R.P.M.
Compression Ratio	7.5 to 1
Compression pressure at 150 R.P.M.	135 to 165 lbs.
Minimum Allowable	90 lbs.
Maximum variation between cylinders	10 lbs.
Cylinder numbering (as viewed from rear (flywheel) of engine):	
Right bank	2-4-6-8
Left bank	1-3-5-7
Firing order	1-8-4-3-6-5-7-2
Oil pressure at 1500 R.P.M.	40 to 65 lbs.
Cooling system capacity	approximately 8 1/2 gals.
	(with Chrysler radiator)
Crankcase capacity	5 qts.
(When full-flow filter element is replaced, add 1 additional qt.)	

Table of Contents

	Page
Ordering of Parts	2
Description	4
Operating Instructions	24
Trouble Shooting	27
Lubrication	32
Maintenance	40
Adjustments	42
Preparation for Storage	50

Foreword

This instruction book is published as a guide and reference to assist in obtaining from the Chrysler Industrial Engine the many hours of low-cost, trouble-free service built into it.

In order to obtain the advantages of these qualities over a long period of time, it is necessary only that the engine be treated with reasonable care.

If followed, these instructions will ensure dependable operation, long service and satisfaction. For extensive repairs or overhaul, it is suggested that an authorized Dealer be consulted, as he has proper equipment and tools for overhaul and repair, and will provide the particular attention of an organization devoted to the interest of service.

Modifications

Slight modifications in design as dictated by field experience or desire to improve the unit, or changes of materials due to inability to procure those originally specified may become necessary. Such changes in design will be obvious and, wherever possible, parts or assemblies will be interchangeable with the original design.

Illustrations

The illustrations in this manual are intended to show typical construction of the various parts. In some instances the shapes or details of the parts illustrated may not exactly represent their actual appearance; however, they will serve to show the servicing methods explained or help to identify parts performing the same function.

●

Ordering of Parts

The exploded views shown in this book are intended to enable the operator to better understand the general construction of Chrysler Industrial Engines, and to assist in ordering parts.

The views are helpful in determining the sequence of assembly and function of the various parts; therefore, they will be of considerable assistance when making adjustments or repairs.

Important

Orders for parts should be placed with the nearest Authorized Dealer. Authorized Dealers are in possession of complete parts information and can, in most instances, promptly supply your parts requirements from their inventory. If you do not know the location of your nearest Chrysler Industrial Engine Dealer, a card addressed to the Chrysler Industrial Engine Division, 12200 East Jefferson Avenue, Detroit (31) Michigan, will bring you his name and address promptly.

Most important in ordering parts is the proper identification of the engine. Always mention the Model, Type and Serial Number. (Sample: Model Ind. 20A type 442, Serial Number 1273). This information is stamped on the identification plate and should be mentioned in all parts orders or communications. The number stamped on the front end of the cylinder block just back of the water pump is a manufacturing code and should not be used for the purpose of identification.

Identification

A brass name plate is attached to the oil filter side of the engine flywheel housing (Figure 1) showing the model symbol, type and serial number of the engine.

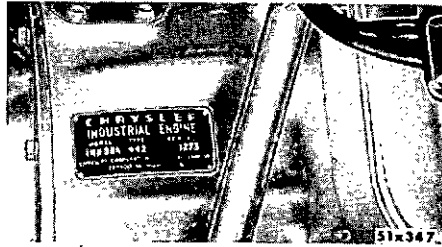

Figure 1 - Identification Name Plate

Important

For your convenience, fill in the information requested below on your own engine. It will then be readily available when needed for identification purposes, should the replacement of parts ever become necessary.

Model

Type

Serial No.

Description

GENERAL

The Chrysler V-8 Industrial Engine, Model Ind. 20A (Figures 2 and 3) is supplied as power for cranes, shovels, winches, road building equipment, generators, welders, farm tractors, irrigation, fire pumps, air conditioning units, and many other heavy duty Industrial installations.

The accessories supplied with the basic engine depend on the type of installation for which the unit is to be used. Figures 2 and 3 show a unit with the Power Take-Off and Heavy Duty Clutch. Other units may include the Gyrol Fluid Drive or a truck type fly-wheel with the 5-speed transmission. The Fluid-Torque Drive (torque converter) is also available.

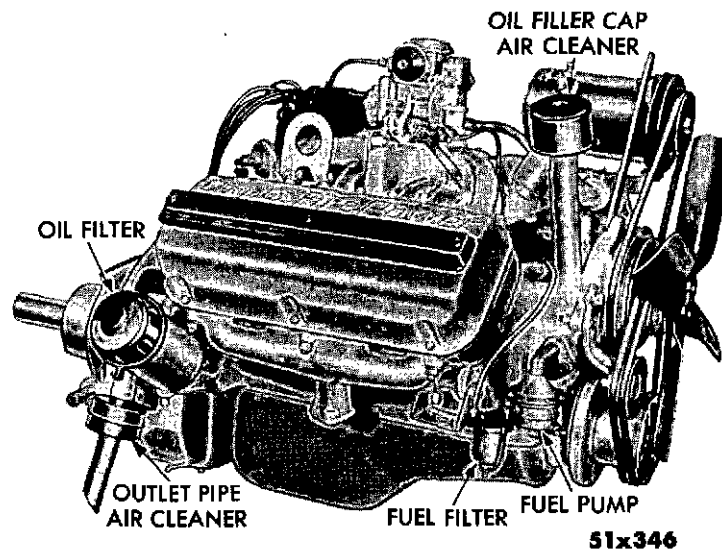

Figure 2 - Chrysler V-8 Industrial Engine,
Model Ind. 20A - Right Side

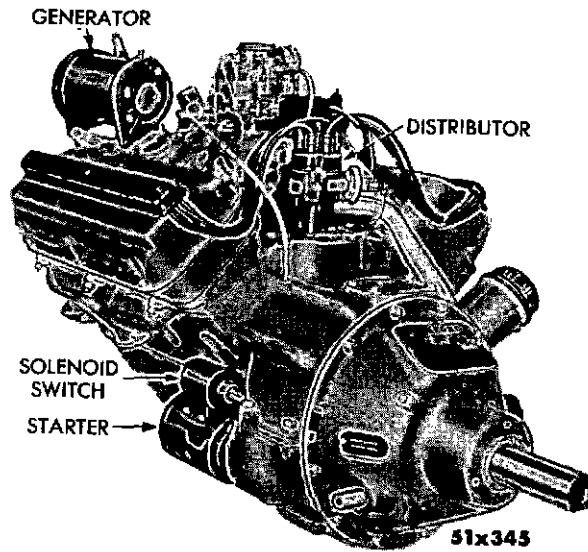
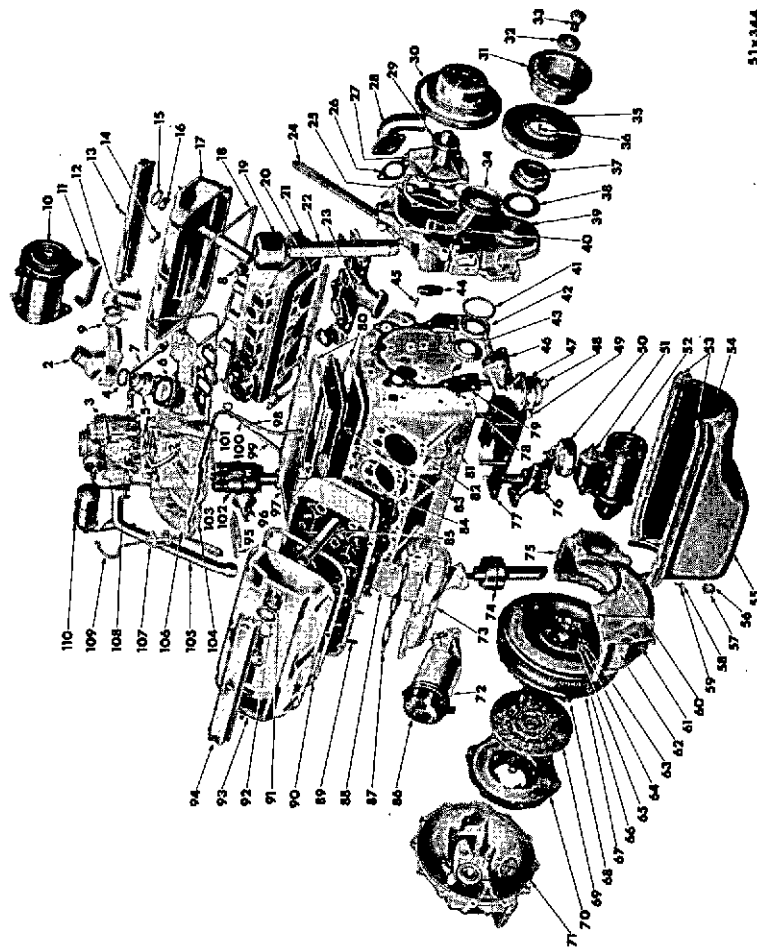

Figure 3 - Chrysler V-8 Industrial Engine,
Model Ind. 20A - Left Side

ENGINE

The basic engine is a V-type eight cylinder, four cycle, gasoline burning unit, with liquid cooling and full pressure lubrication. The valves are of the overhead type. Hydraulically operated valve tappets provide quiet and efficient operation and require no special attention. Figures 4 and 5 show the engine parts completely disassembled. Figure 6 is a sectional view of the engine.

CYLINDER HEADS. One of the most outstanding features of the Chrysler V-8 Industrial Engine, is the hemispherical combustion chambers, located in the cylinder heads (Figure 6). This type of combustion chamber plus the lateral valve arrangement provides the maximum amount of space for extra large valves and permits direct and unrestricted exhaust and intake valve porting.



51x344

Figure 4 - Chrysler V-8 Industrial Engine, External Parts - Exploded View

Ref. No.	Name	Part Type Code	Ref. No.	Name	Part Type Code	Ref. No.	Name	Part Type Code
1	Choke	14-39-45	38	Dust Seal	9-23-28	75	Dowel	9-02-8
2	Elbow	9-05-5	39	Cover	9-23-5	76	Pump Assembly	10-07-6
3	Carburetor	14-30-1	40	Bracket	7-04-5	77	Baffle	10-24-30
4	Gasket	7-41-16	41	Gasket	9-23-21	78	Dowel	9-02-7
5	Thermostat	7-41-4	42	Oil Seal	9-23-18	79	Gasket	9-23-17
6	Gasket	9-05-6	43	Slinger	9-07-17	80	Gasket	9-40-4
7	Tube	14-31-20	44	Snubber	9-20-7	81	Drain Cock	9-02-5
8	Plug	9-03-4	45	Pin	9-20-4	82	Dowel	9-02-8
9	Clamp	7-14-13	46	Gasket	14-74-1	83	Cover	9-40-3
10	Generator	8-26-3	47	Pump	14-73-2	84	Gasket	9-02-5
11	Bracket	8-28-36	48	Connector	14-89-57	85	Tube	8-36-136
12	Hose	7-14-5	49	Connector	14-85-1	86	Cover	10-26-26
13	Screw	8-36-4	50	Strainer	10-23-7	87	Gasket	9-50-5
14	Guide, Cable	8-36-14	51	Switch	8-52-330	88	Block	9-02-5
15	Retainer	8-36-138	52	Starter	8-52-4	89	Stud	9-48-43
16	Seal	8-36-137	53	Gasket	10-24-5	90	Gasket	9-03-29
17	Cover	9-03-28	54	Gasket	10-24-6	91	Seal	8-36-137
18	Gasket	9-03-29	55	Pan	10-24-4	92	Retainer	8-36-138
19	Air Cleaner	10-01-21	56	Gasket	10-24-38	93	Cover	9-03-28
20	Gasket	9-03-5	57	Plug	10-24-37	94	Cover	8-36-4
21	Head	9-03-4	58	Screw	10-24-4	95	Cover	9-47-10
22	Pipe	10-01-9	59	Washer	10-24-4	96	Chamber, Vacuum	8-27-309
23	Manifold	9-48-8	60	Dust Seal	9-47-17	97	Cover	9-40-3
24	Strap	8-28-15	61	Screen	9-47-27	98	Tube	14-85-1
25	Gasket	7-44-4	62	Housing	9-47-5	99	Tube	10-03-7
26	Gasket	7-48-3	63	Nut	9-46-11	100	Indicator	10-03-4
27	Pump	7-42-1	64	Washer	9-46-10	101	Gasket	14-34-2
28	Elbow	7-05-1	65	Stud	9-46-10	102	Distributor	8-27-1
29	Hub	7-05-1	66	Gear	9-45-2	103	Tube	14-31-20
30	Pulley	7-06-14	67	Fluid Drive	9-46-4	104	Gasket	9-50-6
31	Pulley	7-06-1	68	Plate	9-46-10	105	Pipe	10-02-15
32	Washer	9-07-22	69	Disc Assembly	6-13-1	106	Manifold	9-48-7
33	Screw	9-07-5	70	Cover Assembly	6-14-1	107	Tube	9-48-124
34	Pulley	7-04-1	71	Housing Assembly	6-09-1	108	Pot, Dash	14-50-25
35	Damper Assembly	9-13-5	72	Filter	10-26-6	109	Tube	9-48-124
36	Key	9-13-23	73	Manifold	9-48-6	110	Coll	8-36-4
37	Hub	9-13-21	74	Air Cleaner	10-02-8			

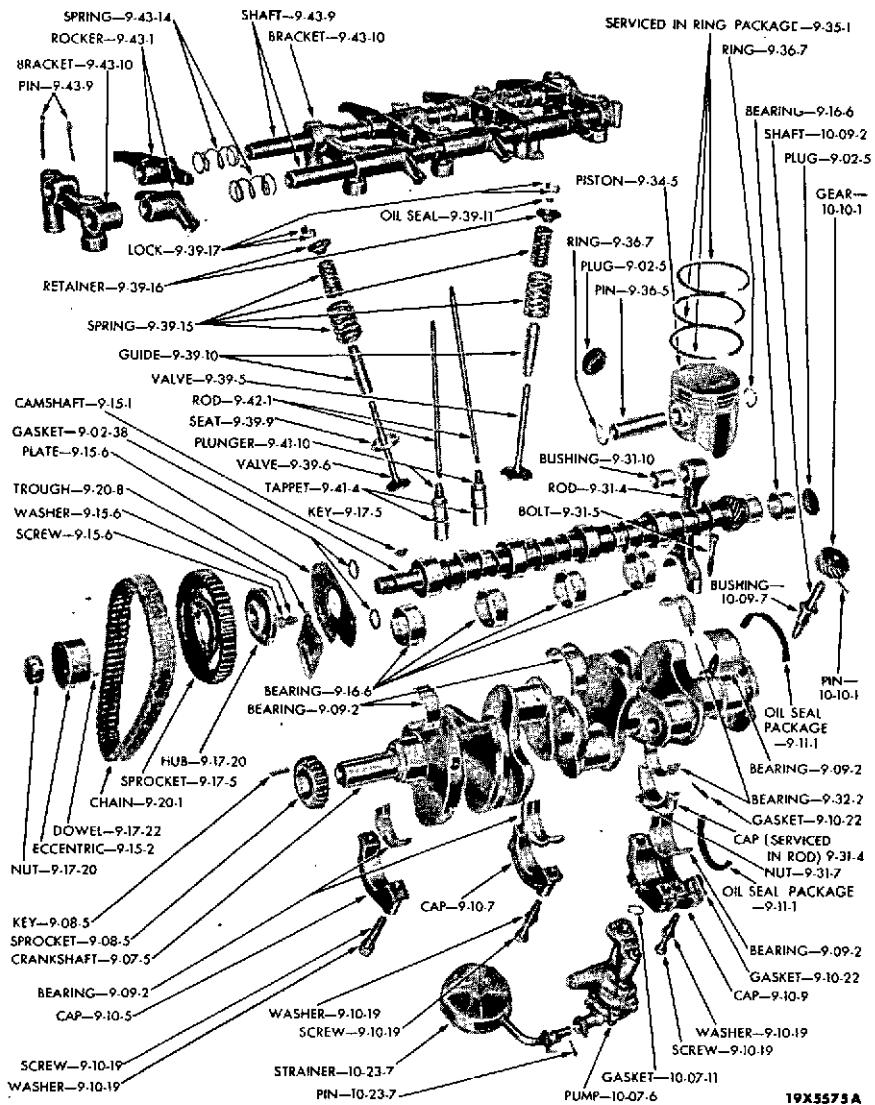

Figure 5 - Chrysler V-8 Industrial Engine,
Internal Parts - Exploded View

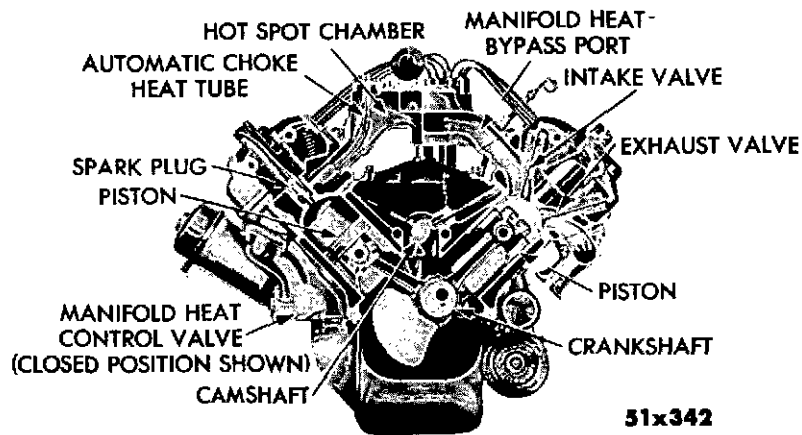

Figure 6 - Chrysler V-8 Engine (Cutaway Sectional View)

LUBRICATION. The engine lubricating system supplies a constant flow of filtered oil to all internal engine parts. The oil pump in the oil pan, driven by the distributor and oil pump drive shaft, draws oil through a floating strainer and forces it through the oil filter to the crankshaft, camshaft, timing gears and valve tappets. Pistons and cylinders are lubricated by splash feed. Crankcase ventilation is provided through a ventilator pipe with an air cleaner, removing fumes and moisture from the crankcase. An air filter on the oil filler pipe cleans air before it enters the crankcase. See figure 2.

ELECTRICAL SYSTEM. The six-volt electrical system includes the storage battery, generator, generator regulator, starting motor, ignition coil, distributor and spark plugs, together with the necessary cables, connecting wires and switches. See figure 7.

DISTRIBUTOR. The distributor used in the ignition system is driven by the distributor and oil pump drive shaft. This device times and distributes the ignition current to each spark plug at the exact instant necessary to fire the mixture in that combustion chamber. On any distributor, when the points open, the primary current through

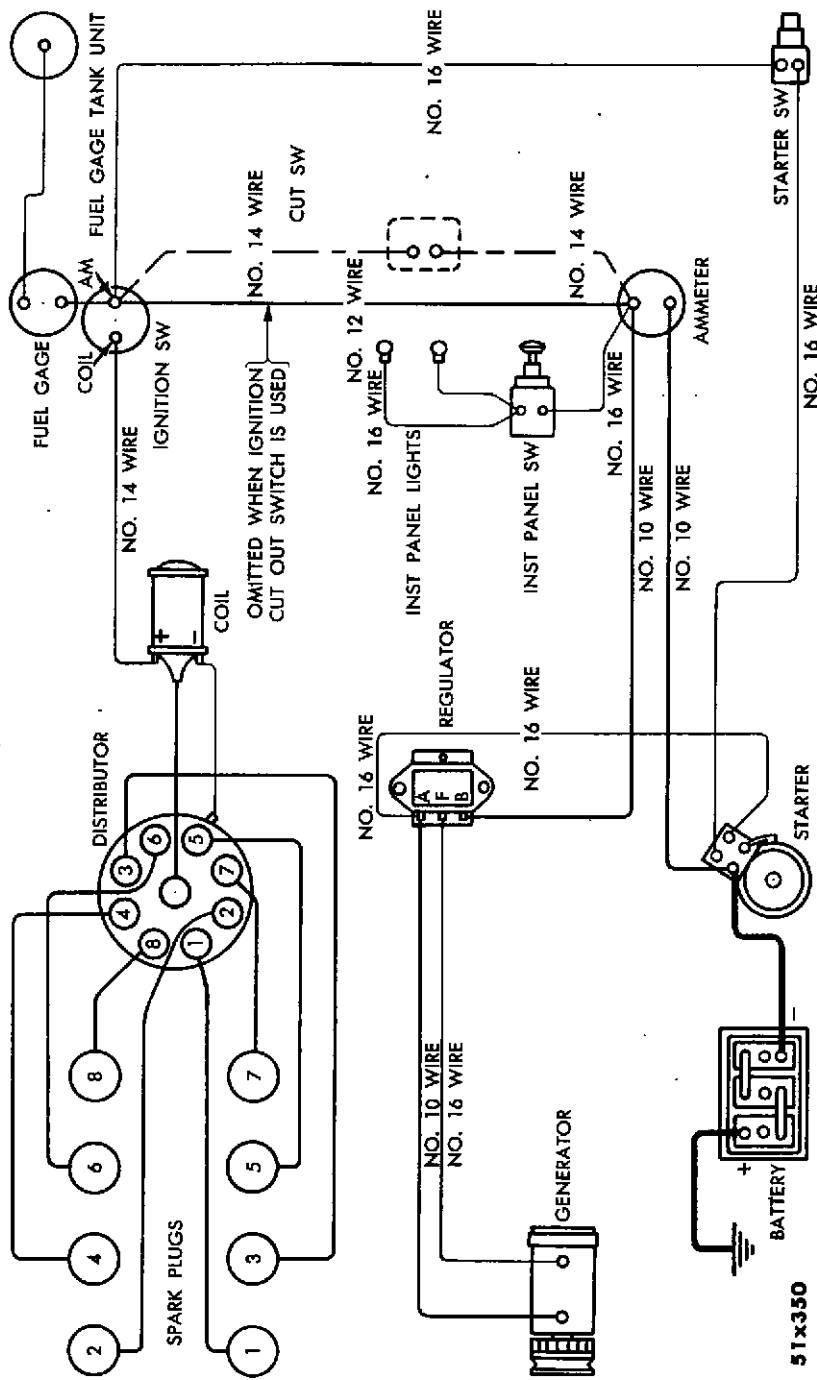

Figure 7 - Wiring Diagram

51x350

the coil is interrupted, causing the magnetic field to collapse suddenly, thus inducing a high voltage in the secondary winding. This high voltage fires the spark plug. The value of this voltage depends on the strength of the primary current at the instant the points open. Primary current starts to build up the instant the points close. The longer the points remain closed, the greater will be the primary current build-up (to the point of saturation), and the higher the voltage induced when the points again open to fire the next spark plug. On an 8-cylinder distributor with only one set of points, the length of time the points are closed when operating at high speed is so short that the primary current does not build up enough for efficient operation. The two sets of points in the distributor of the Chrysler V-8 Engine provide a means of increasing the build-up period for the primary current. The points are connected in parallel between the coil and the ground and are staggered in relation to the 8 lobe cam. The overlapped contacts result in longer coil saturation and as they are in a parallel circuit, no ignition occurs until both contacts are open. Figure 8 shows the positions of the points at various stages of the operation. Automatic spark advance is accomplished through the centrifugal governor in the distributor.

FUEL SYSTEM. The fuel system includes the fuel lines, fuel pump and filter, carburetor, intake manifold and throttle control. Fuel from the tank passes through the filter into the fuel pump, which is driven by an eccentric on the front end of the cam shaft. The fuel pump forces fuel into the carburetor where it is atomized and mixed with air and drawn through the manifold and valves into the combustion chamber.

CARBURETOR. A typical carburetor for the V-8 Industrial Engine is shown in figures 9 and 10. This is a double barrel down draft unit, with automatic choke. The snap action kick-down switch and dashpot unit shown are features peculiar to units equipped with hydraulically operated transmission. The climatic control choke provides efficient operation under all conditions of starting and warm-up. A thermostatic coil controls movement of the choke valve, opening or closing it as required. Overchoking of a warm engine is prevented by

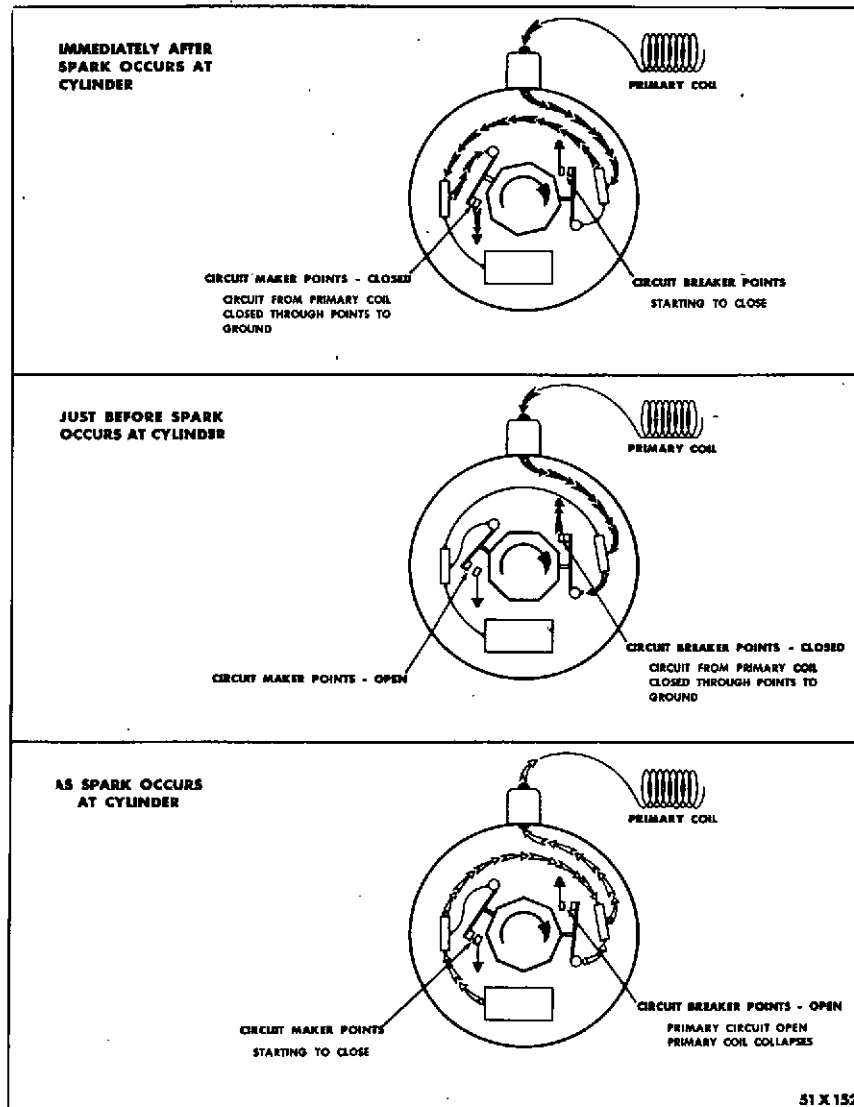
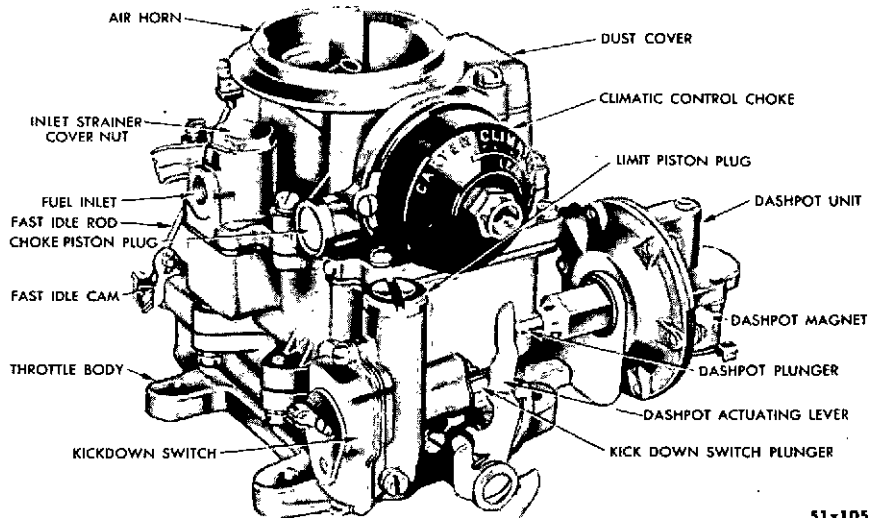
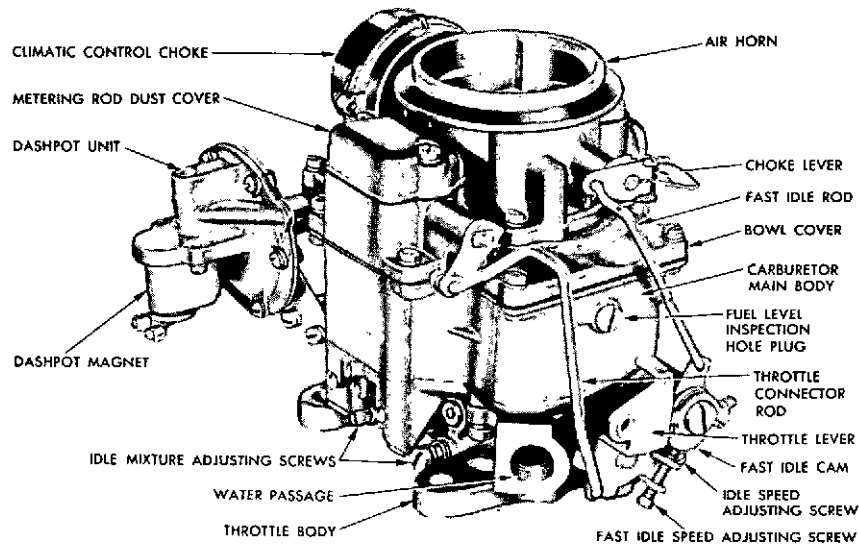

Figure 8 - Distributor (Operational Schematic)



51x105

Figure 9 - Typical Carburetor for V-8 Engine

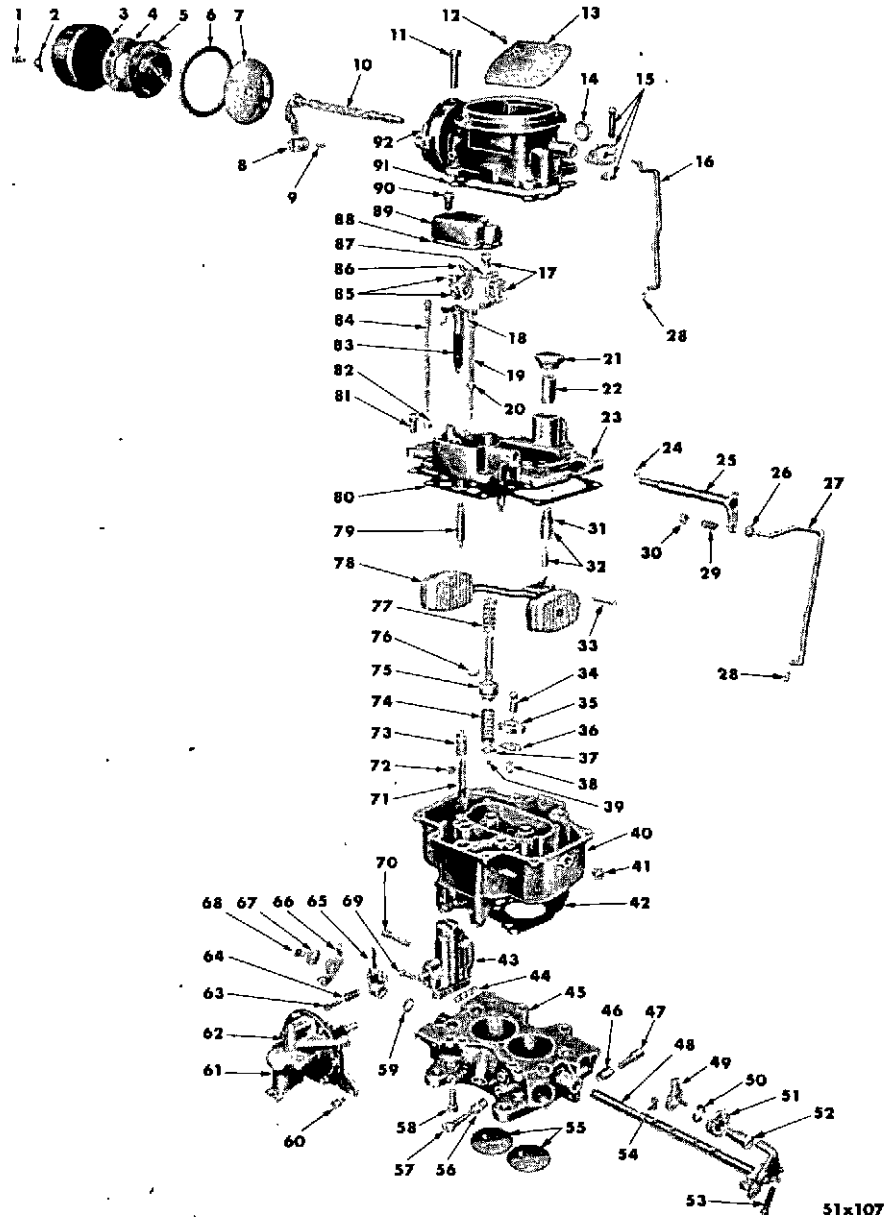

Figure 10 - Carburetor (Exploded View)

Figure 10 - Carburetor (Exploded View) (Contd)

Ref. No.	Name	Part Type Code	Ref. No.	Name	Part Type Code
1	Housing Mounting Screw	14-39-45	48	Throttle Shaft and Lever	14-38-12
2	Housing Retaining Clip	14-39-47	49	Fast Idle Cam Trip Lever	14-45-3
3	Housing	14-39-45	50	Fast Idle Cam Spring	14-45-4
4	Heat Retainer Plate Gasket	14-34-56	51	Fast Idle Cam	14-45-4
5	Thermostatic Coil and Heat Retainer Plate	14-39-45	52	Fast Idle Cam Mounting Screw	14-54-136
6	Housing Gasket	14-34-55	53	Fast Idle Speed Adjusting Screw	14-45-20
7	Baffle Plate	14-39-50	54	Throttle Valve Attaching Screw	14-54-4
8	Choke Piston	14-39-54	55	Throttle Valves	14-38-4
9	Piston Pin (retaining)	14-39-56	56	Idle Mixture Needle Spring	14-36-29
10	Choke Shaft and Lever	14-39-6	57	Idle Mixture Needle	14-45-1
11	Air Horn Attaching Screw, w/Washer	14-54-72	58	Main Body Attaching Screw, w/Washer	14-54-78
12	Choke Valve Attaching Screw	14-54-15	59	Throttle Shaft Retaining Ring	14-38-38
13	Choke Valve	14-39-1	60	Dashpot Mounting Screw, w/Washer	14-54-140
14	Choke Piston Expansion Plug	14-47-1	61	Dashpot Magnet	14-50-26
15	Choke Lever, Screw and Nut	14-39-9	62	Magnetic Dashpot	14-50-25
		14-54-14	63	Dashpot Adjusting Screw	14-54-74
16	Fast Idle Rod	14-39-28	64	Dashpot Adjusting Screw Spring	14-36-33
17	Metering Rod Lifter Arm and Screw	14-35-17	65	Dashpot Actuating Lever	14-50-29
18	Metering Rod Spring	14-36-36	66	Throttle Shaft Lever	14-38-17
19	Metering Rod	14-35-15	67	Throttle Shaft Lever Washer	14-54-131
20	Metering Rod Disc	14-35-20	68	Actuating Lever Retaining Screw	14-38-17
21	Inlet Strainer Cover Nut, w/Gasket	14-37-35	69	Kickdown Switch Mounting Screw (short), w/Washer	14-51-34
22	Inlet Strainer	14-58-2	70	Kickdown Switch Mounting Screw (long), w/Washer	14-51-34
23	Bowl Cover	14-40-12	71	Vacuumeter Spring	14-36-37
24	Countershaft Hairpin Clip	14-41-46	72	Metering Rod Jet	14-35-16
25	Countershaft	14-41-5	73	Vacuumeter Piston, w/Pin	14-35-34
26	Fast Idle Rod Washer	14-54-133	74	Pump Plunger Spring (lower)	14-36-15
27	Fast Idle Rod	14-38-28	75	Pump Plunger	14-41-3
28	Fast Idle Rod Hairpin Clip	14-39-27	76	Spring Retainer (upper)	14-41-3
29	Fast Idle Rod Retainer Spring	14-36-30	77	Pump Plunger Spring (upper)	14-41-3
30	Fast Idle Rod Retainer	14-38-47	78	Float	14-40-1
31	Needle Valve Seat Gasket	14-34-21	79	Low Speed Jet	14-35-13
32	Needle Valve Seat Assembly	14-40-7	80	Bowl Cover Gasket	14-34-22
33	Float Fulcrum Pin	14-40-1	81	Bowl Cover Attaching Screw, w/Washer	14-54-34
34	Discharge Cluster Screw	14-54-150	82	Metering Rod Disc	14-35-20
35	Discharge Cluster	14-35-40	83	Vacuumeter Link	14-35-36
36	Discharge Cluster Gasket	14-34-65	84	Metering Rod	14-35-15
37	Accelerator Plunger Ball Check Retainer	14-41-43	85	Accelerator Pump Arm and Screw	14-41-9
38	Discharge Check Needle	14-41-30	86	Pump Connector Link Hairpin Clip	14-41-45
39	Pump Intake Check Ball	14-37-29	87	Pump Connector Link	14-41-8
40	Main Body	14-49-1	88	Dust Cover Gasket	14-34-60
41	Inspection Hole Plug and Gasket	14-37-14	89	Metering Rod Dust Cover	14-40-20
42	Main to Throttle Body Gasket	14-34-4	90	Dust Cover Attaching Screw, w/Washer	14-40-20
43	Kickdown Switch	14-51-21	91	Air Horn Gasket	14-34-5
44	Kickdown Switch Gasket	14-34-32	92	Air Horn	14-47-1
45	Throttle Body	14-33-1			
46	Idle Speed Adjusting Screw Spring	14-36-1			
47	Idle Speed Adjusting Screw	14-45-25			

means of a heat retainer plate located next to the coil. This plate retards the cooling off of the thermostatic coil, thereby preventing it from closing the choke while the engine is still hot. A fast idle cam on the throttle body is provided for increased idle speeds during warm up. This cam is connected to the choke by means of a lever and rod. A fast idle speed screw on the throttle lever contacts the cam. The throttle body is connected to the cooling system to prevent icing of the throttle valves.

GOVERNOR. Some engines are equipped with a mechanical type governor. This unit is mounted on the fuel pump side of the engine, just above the fuel pump, and is driven by a belt from the double pulley at the fan. Governor weights revolving with the governor main shaft inside the housing actuate the operating lever, which is connected to the carburetor throttle lever. A calibrated spring controls movement of the operating lever to oppose the force exerted by the governor weights. Balance between these two forces governs engine speed. In the Hoof Governor, speed and sensitivity are set at the factory to provide accurate control. However, provision is made for some adjustment to vary sharpness of control, and to correct surge. The Pierce Governors may be adjusted for governed engine speed, as well as for control and to eliminate surge.

VALVE TAPPETS. The hydraulic tappets which operate the push rods are designed for quiet and efficient operation. Service adjustments are eliminated. These units automatically compensate for variations in the valve train resulting from temperature changes, using oil as the compensating factor.

EXHAUST VALVE ROTATORS (Figure 11).

Some of the industrial engines are equipped with exhaust valve rotators to provide positive rotation of the exhaust valves each time they open. Their purpose is to prolong the life of exhaust valves.

The rotators are installed on the valve stems in place of the conventional valve spring retainers, using the same locks.

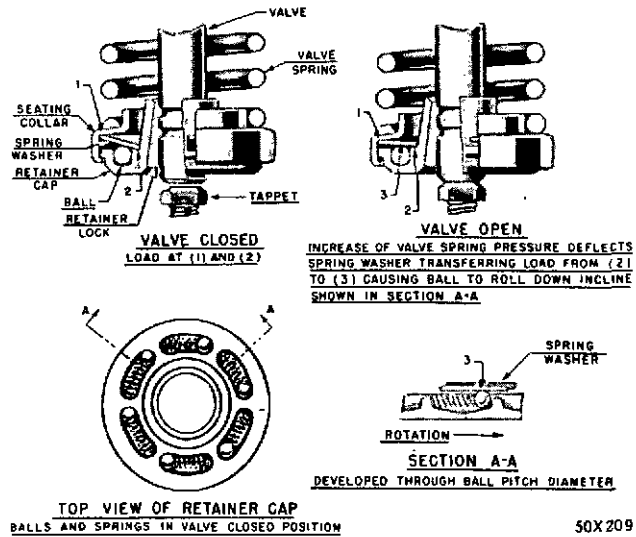

Figure 11 - Exhaust Valve Rotators (Cutaway Sectional Views)

When rotators are used on the exhaust valves, special valve springs are used, which are not interchangeable with intake valve springs.

CARBURETOR AIR CLEANER. A heavy duty oil bath type air cleaner protects the carburetor against dirt and other foreign matter which might otherwise enter the engine through the carburetor.

EXHAUST SYSTEM. Exhaust from the combustion chambers passes through the exhaust valve ports into the exhaust manifold and out through the exhaust pipe. Some engines are equipped with a manifold heat control valve, which permits faster warm-up of the engine by diverting the exhaust from the right engine bank through a bypass port and hot spot chamber in the intake manifold and out through the left exhaust manifold.

The manifold heat control valve is located between the right exhaust manifold and the exhaust pipe. It consists essentially of a

butterfly type valve operating on a shaft in a housing. Movement of the valve is controlled by a flat coil spring and a counterweight. The inner end of the spring fits in a slot in the valve shaft; the outer end contacts one of two stop pins; which also serve to limit travel of the valve. The counterweight fits over the outer end of the valve shaft, and is held with a key and clamp bolt. Bumpers and an anti-rattle spring keep the mechanism quiet.

When the engine is cold, the tension of the coil spring holds the valve in the closed position, restricting the exhaust passage. As the engine warms up, the spring loses enough tension to permit the counterweight to rotate the shaft and open the valve. The outer end of the spring must contact the correct stop pin to provide proper spring tension. Otherwise, the counterweight cannot overcome the spring tension to open the valve.

The heat tube from the carburetor automatic choke is located in the hot spot chamber of the intake manifold. Therefore, efficient operation of the automatic choke depends upon proper functioning of the manifold heat control valve.

COOLING SYSTEM. The belt driven, centrifugal type water pump circulates water from the heat exchanger or radiator to the cylinder block, completely around each cylinder bore, through the cylinder heads, around the exhaust valve ports into special passages in the intake manifold and thence to the thermostat housing for recirculation or return to the radiator or heat exchanger.

The thermostat restricts flow of the water to the radiator until the water has reached a predetermined temperature, thereby permitting faster warm-up of the engine.

A bypass passage and tubes from the intake manifold provide circulation through the carburetor throttle body. On units equipped with fluid-torque drive, an oil cooler is also connected to the cooling system.

Three drain cocks are provided for draining the cooling system, one in the radiator and one at each side of the cylinder block near the exhaust manifold outlet. All three must be open to drain the system completely.

FLUID DRIVE

The fluid drive in some units (Figure 12) serves to connect the engine crankshaft to the clutch. This unit consists essentially of an impeller and a turbine enclosed in an oil filled doughnut shaped housing. The vaned impeller, driven by the engine crankshaft, sets the oil in a rotary motion, actuating the vaned turbine, which is riveted to a hub keyed to the clutch driving plate. The hub rotates on a bearing submerged in the oil.

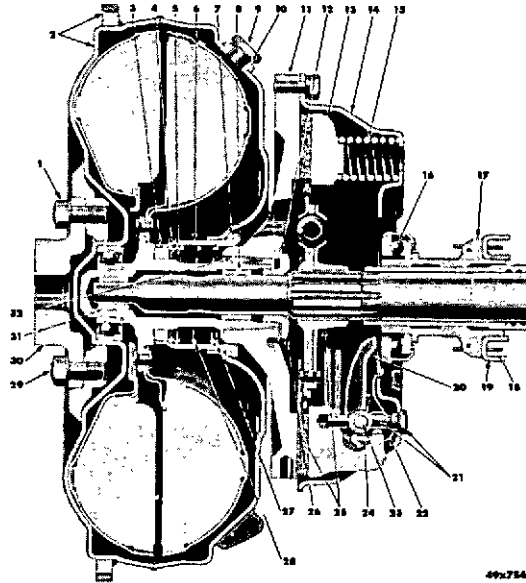

Figure 12 - Clutch and Fluid Drive (Sectional View)

- | | |
|--|---|
| 1 - Fluid drive flange stud nut | 17 - Clutch release bearing sleeve |
| 2 - Fluid drive assembly | 18 - Clutch release bearing sleeve pull-back spring |
| 3 - Fluid drive floating seal ring | 19 - Clutch release fork |
| 4 - Fluid drive seal ring gasket | 20 - Clutch release lever |
| 5 - Fluid drive seal ring gasket retainer | 21 - Clutch release lever eyebolt and nut |
| 6 - Fluid drive seal assembly | 22 - Clutch release lever spring |
| 7 - Fluid drive seal retainer gasket | 23 - Clutch release lever pin |
| 8 - Fluid drive runner bushing - rear | 24 - Clutch release lever strut |
| 9 - Fluid drive filler plug | 25 - Clutch disc assembly |
| 10 - Fluid drive filler plug gasket | 26 - Fluid drive driving plate nut |
| 11 - Fluid drive clutch driving plate | 27 - Fluid drive seal spring retainer snap ring |
| 12 - Fluid drive driving plate lock washer | 28 - Fluid drive seal spring |
| 13 - Clutch pressure plate | 29 - Fluid drive driving flange stud |
| 14 - Clutch cover | 30 - Crankshaft |
| 15 - Clutch pressure spring | 31 - Fluid drive runner bushing - front |
| 16 - Clutch release bearing | 32 - Fluid drive driving plate key |

FLUID-TORQUE DRIVE

The fluid-torque drive (Figure 13) in some units is somewhat similar to the fluid drive so far as principle of operation is concerned. The vanes in the impeller and turbine of the fluid-torque drive are curved, while those in the fluid drive are straight. In addition to this feature, there are two sets of stationary reaction vanes, or stators, located between the impeller and the turbine. The curved vanes of the impeller increase the acceleration and energy of oil flow into the turbine; the curved vanes of the turbine readily absorb the energy from the impeller. The stators direct the flow of oil as it leaves the turbine vanes into the impeller vanes with the direction of rotation, rather than against it, resulting in increasing the torque from the engine by a variable ratio up to 2.34 to 1 at stall. A rotary oil pump draws oil from the oil reservoir to the impeller. An oil cooler which is connected to the cooling system prevents overheating and thinning of the oil.

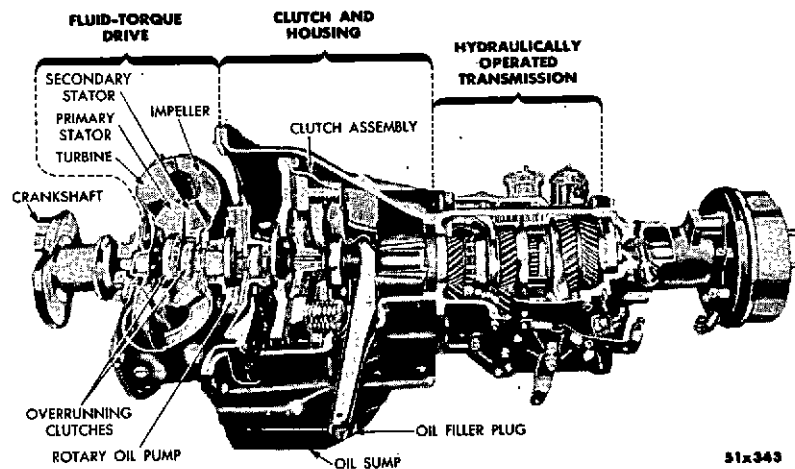

Figure 13 - Fluid-Torque Drive and Hydraulically Operated Transmission

CLUTCH

The type of clutch used is determined by the type of adaptation. On units equipped with fluid drive or fluid-torque drive, the turbine shaft is attached to the driving plate of the clutch. When the clutch is engaged, the clutch disc, which is splined to the transmission drive pinion, is clamped between the clutch driving plate and the clutch pressure plate to transmit power to the transmission. The unit is controlled by the clutch release through the clutch release fork and linkage to the clutch pedal or lever.

In units not equipped with fluid drive, fluid-torque drive, or power take-off with heavy duty clutch, the clutch cover is attached to the engine flywheel. When the clutch is engaged, the clutch disc is clamped between the pressure plate and the flywheel; drive is transmitted from the cover through the pressure plate to the disc and thence to the transmission.

5-SPEED TRANSMISSION

One of two 5-speed transmissions may be used in the unit (Figures 14 and 15). These transmissions are similar in design and operation, but the heavy duty transmission shown in Figure 14 is more widely used. In either unit, there are five forward speeds and one reverse. Direct drive is in fifth speed.

HYDRAULICALLY OPERATED TRANSMISSION

The hydraulically operated transmission used on some units is a 2-range, 4-speed geared transmission. See Figure 13. A manual shift provides a means of selecting reverse or high or low range. Shifting from first to second or from third to fourth speed is accomplished by momentarily closing the throttle at an engine speed over 500 rpm. Downshifts occur automatically at an engine speed of approximately 450 rpm in either range.

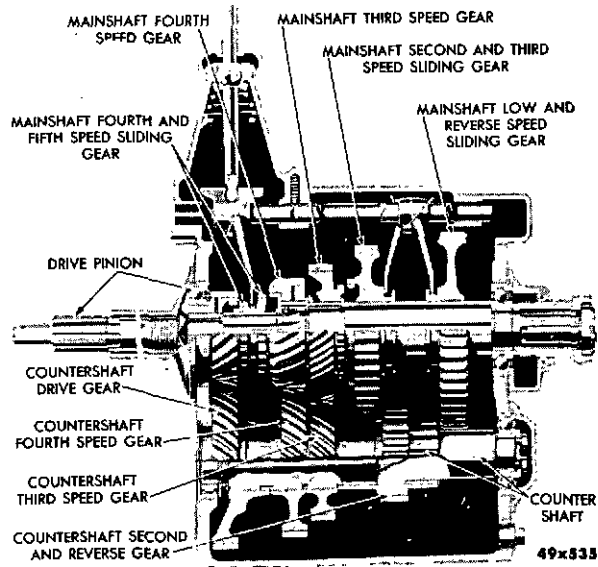

Figure 14 - 5-Speed Transmission

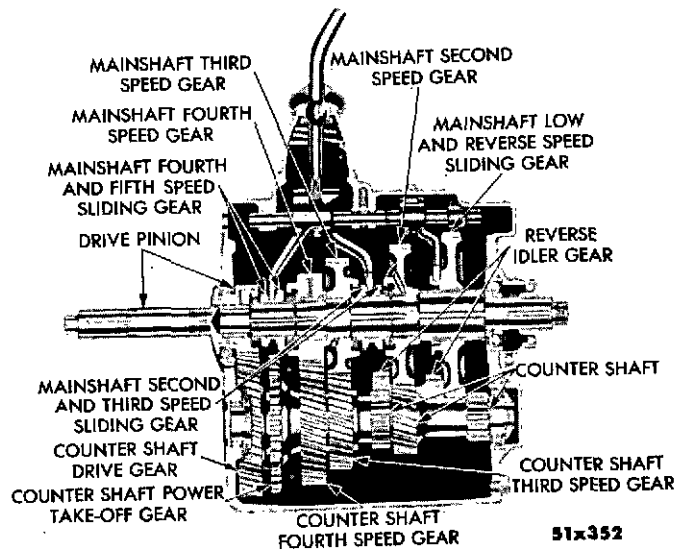

Figure 15 - 5-Speed Heavy Duty Transmission

Power Take-off with Heavy Duty Clutch

The power take-off and clutch assembly (Figure 16) used with some industrial engines is a heavy duty unit consisting of a three section dry disc clutch and a drive shaft enclosed in a special housing which is bolted to the engine. The clutch drive ring is attached to the engine flywheel and drives the pressure plate by means of internal gear teeth. When the clutch is engaged, the pressure plate is clamped between the discs, engaging the clutch body which is keyed to the drive shaft. The drive shaft is supported by a double row ball bearing at the front and by two tapered roller bearings at the rear of the housing. The clutch release lever controls the clutch release bearing through a clutch yoke which engages the clutch release bearing trunnion. Positive disengagement of the clutch mechanism is accomplished through a toggle arrangement acting in conjunction with the return springs. A threaded adjusting nut in the clutch provides a means of compensating for wear.

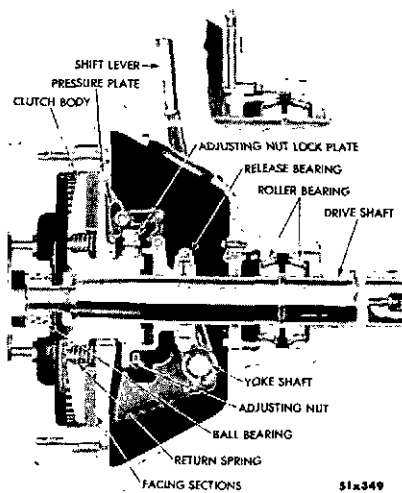

Figure 16 - Power Take-Off, With Heavy Duty Clutch
(Sectional View)

Operating Instructions

PREPARATION OF A NEW ENGINE

Before placing a new or rebuilt engine in service, make a thorough inspection for evidence of damage or loose parts.

ENGINE OIL. See that the crankcase contains the correct amount of clean new SAE 10-W engine oil.

COOLING SYSTEM. Fill the cooling system with water, using anti-freeze solution, if temperature requires it. In warm weather, the use of MOPAR Rust Resistor is recommended.

ENGINE ACCESSORIES. See that all points requiring lubrication are properly supplied. Check storage battery terminals to see that they are tight and clean. Check the electrolyte in the battery.

ELECTRICAL CONNECTIONS. See that all electrical connections are tight and clean. Check each spark plug for tightness.

ATTACHING PARTS. See that all nuts, bolts and screws that attach parts are secure.

PRESTARTING INSTRUCTIONS

When the engine is in daily use, inspect it daily and always before starting after a period of idleness.

ENGINE OIL LEVEL. Inspect the oil level and add oil if required.

FUEL. Check the fuel supply.

COOLING SYSTEM. Inspect the cooling system and add water or anti-freeze as required.

TIPS ON ENGINE CARE

NEW OR REBUILT ENGINES. It is good practice not to operate a new or rebuilt engine at more than $3/4$ throttle for the first 8 or 10 hours. This low speed will permit the bearings to seat properly, and will allow the operator to familiarize himself with the controls and performance of the engine.

No. 10-W engine oil should be used in the engine during the break-in period because the clearance between moving parts is very small and the light oil provides assured lubrication. Keep the oil at the proper level. After 25 hours of operation, the crankcase may be drained and refilled with oil as recommended in the Lubrication Section.

COLD ENGINES. When starting a cold engine (whether new or not), avoid unnecessary acceleration during the warm-up period. Keep the throttle at little more than idling speed until normal operating temperature is indicated on the temperature gauge. This simple precaution will assure long life of the engine and maximum efficiency of operation.

STARTING AND STOPPING THE ENGINE

STARTING. Open the throttle at $1/3$ opening. See that the clutch, gear shift lever or power take-off lever is in neutral position. Turn on the ignition switch and press the starting motor switch until the engine starts. Do not hold the starting motor switch in for periods longer than 15 seconds if the engine does not start promptly. After the engine starts, watch the oil pressure gauge. If oil pressure does not register after about 10 seconds, stop the engine and investigate.

STOPPING. To stop the engine, first close the throttle and disengage the clutch. Allow the engine to run at idle speed for a few minutes; then, with the throttle closed, turn off the ignition.

PRECAUTIONS

WARM-UP PERIOD. After starting a cold engine, operate it at a speed only slightly faster than idle (approximately 700 rpm) for a few minutes to allow the engine to reach normal operating temperature before placing it under full load. This warm-up period will permit oil to reach all bearing surfaces, thus reducing the possibility of scoring and premature wear of internal engine parts.

OIL PRESSURE. With the engine turning at approximately 2000 rpm and the water temperature at 160°F., the oil pressure should be from 45 to 55 pounds, providing there is no abnormal escape of oil from some point. As bearings wear and the increased clearances permit more than the normal escape of oil, there will be a drop in pressure shown on the gauge, particularly at idling speed. A drop in oil pressure may also be the result of a plugged oil filter element.

WATER TEMPERATURE. A thermostat in the cylinder block retards the circulation of liquid in the cooling system until the liquid has reached a predetermined temperature, thereby permitting faster warm-up of the engine. Do not operate the engine with the thermostat removed, as this unit is essential to proper circulation and efficient engine performance. Without the thermostat, sludge will form in the crankcase because the low temperature of the engine permits condensation of fumes in the crankcase. When operating in hot climates, the maximum reading of the temperature gauge should not exceed 100°F. above the prevailing atmospheric temperature.

AIR CLEANERS. Remove and service the carburetor and oil filler cap and crankcase ventilator outlet air cleaners every 50 hours or less, depending on the severity of working conditions.

IGNITION SYSTEM. Keep the units of the ignition system clean and properly adjusted.

FUEL SYSTEM. Keep the fuel tank, lines and filters clean. Always use a good grade of fuel.

COOLING SYSTEM. Do not fill the cooling system when the engine is overheated. Allow the engine to cool before adding liquid, in order to prevent cracking the cylinder blocks. Use a good grade of anti-freeze during cold weather, and MOPAR Rust Resistor during warm weather.

POWER TAKE-OFF AND CLUTCH ASSEMBLY

On units equipped with the Power Take-Off and Clutch Assembly, avoid unnecessary use of the shifting lever. Frequent engagement and disengagement of the clutch causes rapid wear of clutch facings, necessitating frequent adjustment and replacement of parts. Do not attempt to engage or disengage the clutch while the engine is accelerated. Do not operate the unit when the clutch is slipping. See Adjustment Section.



Trouble Shooting

A good rule to follow when trouble shooting is to make only one adjustment at a time. Locate the cause of failure or irregular operation by the process of elimination.

STARTER WILL NOT TURN ENGINE

LOOSE OR CORRODED BATTERY TERMINALS. Remove cable connections at battery and ground, clean and tighten securely.

BATTERY NOT FULLY CHARGED. Test the electrolyte in the battery. The specific gravity of a fully charged battery is 1.275. If the hydrometer reading is below 1.225, replace the battery with one fully charged.

INOPERATIVE STARTER. If the starter fails to run when the starter switch is closed, inspect all wiring connections to see that they are clean and tight. If there are no loose or corroded connections, inspect the starting motor for loose, worn, or corroded brushes or corrosion on the commutator. To test the starting motor, disconnect the cable from the battery terminal of the solenoid and touch it firmly to the solenoid starter terminal. If the starting motor operates, the trouble is not in the starting motor. If the motor fails to operate and a heavy arc occurs when the cable touches the solenoid starter terminal, a mechanical lock-up of the motor or pinion, or a grounded condition in the motor may be the cause. Failure of the motor to operate and no arc in the preceding test indicates poor brush contact or an open circuit in the motor windings. Remove the starting motor and test off the engine to determine if the trouble is electrical or mechanical. Repair or replace the starting motor as required.

SOLENOID OR STARTER SWITCH. To test the switches, remove the relay cover from the solenoid and observe whether the relay points close when the starter switch is closed. If the points close and the starting motor fails to operate, clean the relay points with 00 sandpaper and retest. If the points do not close, connect a jumper across the terminals of the starter switch. If the points now close, a faulty starter switch is indicated. Replace the starter switch. If the points do not close, replace the relay or the complete solenoid, as required.

STARTER PINION JAMS OR BINDS. Check to see that the nuts that hold the starter on the housing studs are tight. Loose attaching parts will cause misalignment of the starter pinion with the flywheel. Another cause may be incorrect pinion clearance. Too little clearance will permit the pinion to travel too far into the flywheel teeth, causing binding. Too much clearance will prevent full engagement of the pinion, causing the pinion to jam and chip the flywheel teeth. To adjust pinion travel, remove the starter from the engine, and adjust the pinion as described in the Adjustment Section, page 8.

ENGINE WILL NOT START

WEAK BATTERY. Battery run down because of low charging rate, resulting from a loose generator belt or a faulty generator or generator regulator.

LOOSE, DAMP, OR CORRODED CONNECTIONS. Corrosion at battery terminals or loose or damp connection at distributor, coil or spark plugs.

FOULED OR DAMP SPARK PLUGS OR INCORRECT GAP. Fouling of spark plugs caused by incorrect carburetor adjustment. Clean and dry plugs and set gap at .035 inch. Adjust carburetor.

DIRTY, WORN, OR INCORRECTLY ADJUSTED DISTRIBUTOR CONTACT POINTS. Clean both sets of points and examine for pitted and worn surfaces. The gap should be .015 to .018 inch. Replace worn points. When replacing the points, apply a small amount of MOPAR cam lubricant (Part No. 1473595) to the rubbing blocks.

COIL OR CONDENSER. Check spark at spark plugs to test for sufficient current.

DIRT OR MOISTURE IN FUEL SYSTEM. Check fuel lines to see that fuel reaches carburetor. Remove fuel level sight plug from carburetor to inspect fuel level, which should be at the lower edge of the sight plug opening.

POOR PERFORMANCE

Poor performance, such as lack of power, stalling, and missing at various speeds may be caused by an inferior grade of fuel; overheating, resulting from low oil level, insufficient liquid in cooling system, a loose fan belt or inoperative manifold heat control valve; ignition system difficulties; fuel system difficulties; or lack of compression resulting from burned or pitted valves or valve seats, or worn or broken piston rings.

FUEL SYSTEM DIFFICULTIES

FUEL DOES NOT REACH CARBURETOR. Clogged vent in fuel tank, dirty strainer element in fuel pump, restrictions in fuel line, or worn fuel pump valve or ruptured diaphragm.

FUEL REACHES CARBURETOR, BUT DOES NOT REACH CYLINDERS. Dirt in carburetor channels, float needle valve sticking in valve seat or incorrect float level, or lack of sufficient vacuum in intake manifold. See your Dealer.

CARBURETOR FLOODED. Inoperative automatic choke or carburetor float system.

FUEL PUMP NOT OPERATING. Loose fuel line fittings between filter and pump, leaking fuel pump valves or diaphragm assembly, or a weak or broken rocker arm spring. Fuel leaks at the fuel pump are an indication of loose fittings, worn or ruptured diaphragm or loose diaphragm mounting screws. See your Dealer.

IGNITION DIFFICULTIES

PRIMARY CIRCUIT. Primary circuit difficulties usually are caused by loose, broken, dirty or corroded connections, a grounded condenser, burned distributor contact points or incorrectly set points or sticking of the contact breaker arm.

SECONDARY CIRCUIT. Secondary circuit difficulties are usually caused by fouled or broken spark plugs, incorrect spark plug gap, wrong type of spark plug, a cracked or wet distributor cap, a faulty coil or a broken distributor rotor contact spring. Repair or replace parts as required.

BURNED OR PITTED DISTRIBUTOR CONTACT POINTS. Dirt or oil on points, incorrect setting of points, a faulty coil or condenser, or high voltage in the system.

COIL FAILURE. Excessively high voltage, moisture formation, engine overheating, or an open circuit at soldered connection on primary studs.

CONDENSER FAILURE. Normal fatigue, excessive heat or moisture formation.

FOULED OR BURNED SPARK PLUGS. Incorrect type of spark plug, spark plug *not sufficiently tight*, too much oil in carburetor air cleaner, incorrect carburetor adjustment, or inoperative automatic choke, incorrect ignition timing, water in combustion chamber, or oil leaking past piston rings.

ENGINE NOISES

PISTON NOISES. Broken piston ring or ring land, too tight or too loose piston pins, excessive clearance between pistons and bore, broken pistons or carbon deposits in cylinder head. See your Dealer.

VALVE NOISES. The hydraulic valve tappets are designed for quiet and efficient operation for an indefinite period of time and usually require no special attention. Oil pressure and oil level affect the operation of the tappets, since oil in the valve oil galleries acts as a compensating factor to maintain a zero clearance throughout the valve train. Low oil pressure or low oil level restricts flow of oil into the valve galleries, causing tappet noise. If the oil level in the crankcase is too high, the oil has a tendency to foam, thereby permitting air to enter the galleries and cause noise. Actual valve noises may be caused by wear of the rocker arms, worn valve guides or stems or broken valve springs. See your Dealer.

CONNECTING ROD NOISES. Low oil pressure, low oil level or thin or diluted oil, incorrect rod alignment, excessive bearing clearance or incorrectly fitted bearings or bearing caps. Inspect and correct oil level and pressure or see your Dealer.

MAIN BEARING NOISES. Low oil pressure, low oil level or thin or diluted oil, excessive bearing clearance or end play, eccentric or out of round journals or a sprung crankshaft. A loose flywheel or fluid drive may be mistaken for main bearing difficulty. See your Dealer.

Lubrication

ENGINE

OIL RECOMMENDATIONS:

For temperature not lower than 32° F.	Use SAE 30
For temperature as low as 10° F.	Use SAE 20-W
For temperature as low as -10° F.	Use SAE 10-W
For temperature below -10° F.	Use SAE 5-W

DILUTION OF ENGINE OIL. If SAE 5-W engine oil is not available, the oil should be diluted with gasoline to assure proper lubrication and easy starting. To dilute the oil, first fill the crankcase with SAE 10-W oil so that the oil level registers at "FULL" on the indicator. Then add one pint of gasoline and run the engine for five minutes to mix the oil and gasoline thoroughly. Stop the engine and note the reading on the oil level indicator. Scribe a line on the indicator showing the level after dilution. The dilution of the oil will increase the oil consumption; therefore the oil level should be checked frequently. While the engine is operating, maintain the level at "FULL" by adding SAE 10-W engine oil. If, after four hours of operation, the engine is to be unprotected while idle for a period of five hours or more, redilution will be necessary. For redilution, first bring the level to "FULL" on the indicator by adding SAE 10-W oil, then add gasoline to raise the level to the scribe mark previously made.

CHANGING OIL. Frequency of oil change is determined by the type of operation and by operating conditions. Under normal operating conditions, oil should be changed after each 50 hours of operation. High speed, heavy load and extremely dusty conditions necessitate more frequent changes. A comparison of the oil on the indicator with fresh oil will usually serve as a guide. Lack of body, the presence of dirt or grit and excessive darkening of the oil indicate that fresh oil is needed. The oil capacity is 5 quarts. If the full flow filter is used, add one additional quart when the filter element

is replaced. Drain the oil while the engine is hot, as the oil will flow freely and will carry more dirt and other foreign matter with it.

ADDING OIL. Between oil changes, check the oil level daily. The oil level indicator (Figure 16) is of the bayonet type, with two markings, "FULL" and "ADD OIL." After the engine has been standing, the oil level should be at the "FULL" mark. After the engine has started, this level will drop somewhat, due to the filling of oil passages and the oil filter. A quart of oil should be added when the level is at or slightly below the "ADD OIL" mark. Do not run the engine with the oil level below the "ADD OIL" mark.

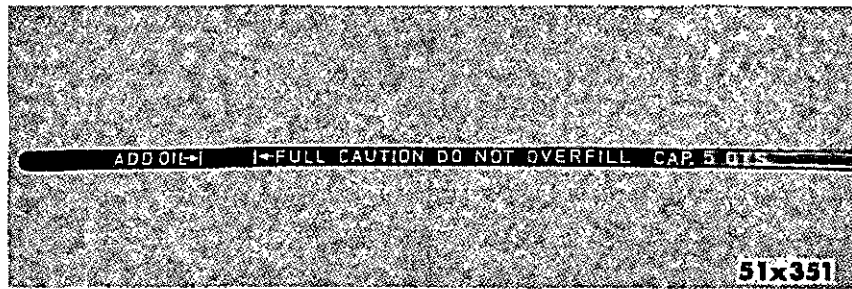

Figure 17 - Oil Level Indicator

COLD WEATHER OPERATION. During cold weather, examine the oil daily for evidence of sludge or water resulting from condensation of moisture in the crankcase. Under extreme conditions, the engine may not reach normal operating temperature during a short run, with the result that fumes are not dissipated in the crankcase and sludge forms. This sludge may freeze or clog the oil inlet strainer, retarding lubrication of internal parts. If there is evidence of sludge, change the oil. If excessive sludge accumulation is evident, remove the oil pan and clean all accessible parts, including the oil inlet strainer, as thoroughly as possible. Use a new oil pan gasket when installing the oil pan.

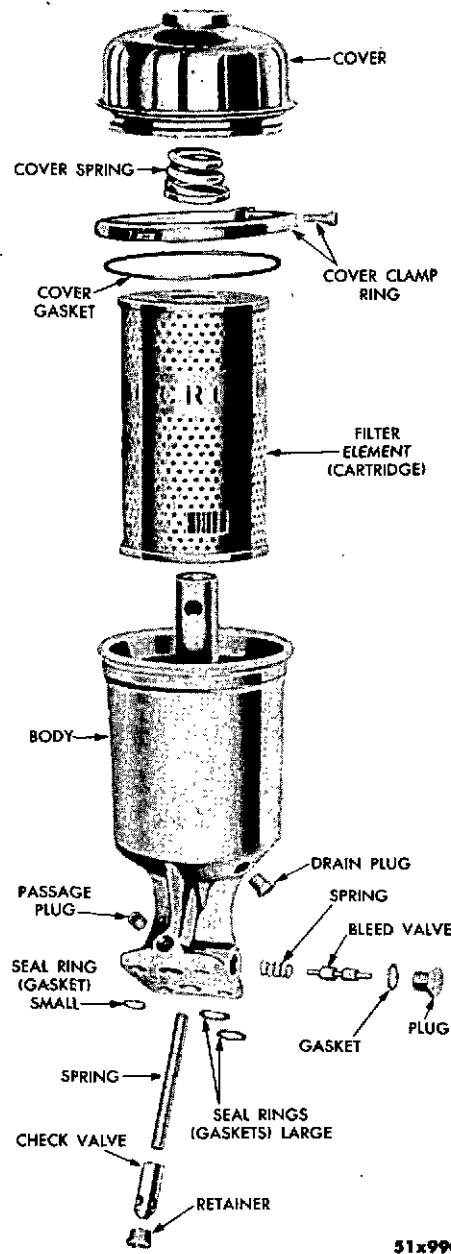

Figure 18 - Full Flow Oil Filter (Exploded View)

OIL FILTER

The full flow oil filter (Figure 18) cleans the oil as it comes from the oil pump. Replace the filter element after each 100 hours of operation or oftener, as conditions demand.

TO REPLACE FILTER ELEMENT. While the engine is warm, remove the filter drain plug and drain the oil. Remove the clamp screw from the clamp ring, open the ring and remove the filter cover, the cover gasket and the filter element. Wipe the housing clean and install the new filter element. Install a new cover gasket and the cover. Close the clamp ring and install the retaining screw. Be sure the drain plug is in place before starting the engine.

CARBURETOR AIR CLEANER

The carburetor air cleaner (Figure 19) should be inspected after each 50 hours of operation or oftener, depending on operating conditions. Dirt level above the lower off-set in the reservoir calls for cleaning of the unit.

PROCEDURE. Remove the cover filter element and clean in kerosene. Allow to drain. Unscrew the clamp screw and remove the reservoir and the gasket between the reservoir and the carburetor. Clean the reservoir thoroughly and install the reservoir with the gasket on the carburetor. Be sure the gasket is in good condition. Use a new gasket, if possible, and be sure the reservoir fits securely on the carburetor, then tighten the clamp screw. Refill the reservoir to the indicated level with one pint of SAE 50 engine oil for temperatures above 32° F., or SAE 20-W for temperatures consistently below 32° F. Do not overfill reservoir, as excess oil in the air cleaner may be sucked into the carburetor and the engine. Install the filter element and cover.

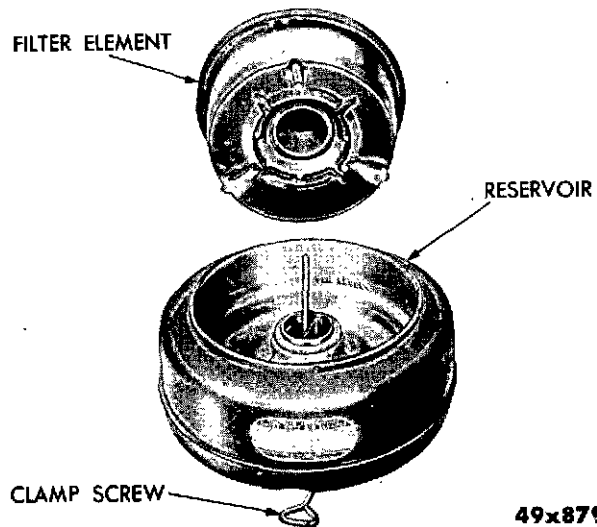

Figure 19 - Typical Carburetor Air Cleaner (Exploded View)

CRANKCASE VENTILATING AIR CLEANERS

After each 50 hours of operation, or with each oil change, remove the air cleaner from the oil filler pipe and one from the ventilator outlet pipe, wash in kerosene, dry and reoil with SAE 50 engine oil.

WATER PUMP

The water pump has one fitting. Lubricate after each 25 hours of operation with water pump grease.

GENERATOR

The generator has two oil cups, one at either end. Lubricate with five to ten drops of SAE 10 engine oil after each 50 hours of operation.

DISTRIBUTOR

The distributor has an oil cup at the side. Lubricate with five or ten drops of SAE 10 engine oil after each 50 hours of operation. After 250 hours of operation, remove the distributor cap and rotor and apply two or three drops of SAE 10 engine oil to the cam wick.

CAUTION: Keep oil away from the contact points.

GOVERNOR

Lubrication is the same for both the Pierce governor and the Hoof governor. Check the oil level in the governor housing daily by removing the inspection hole plug at the rear of the housing. The level should be even with the lower edge of the inspection hole. To replenish the oil, remove the filler hole plug at the top of the housing and fill with engine oil until oil reaches the correct level. Use oil of the same viscosity as that in the engine crankcase.

FLUID DRIVE

The oil in the fluid drive is retained by means of seals, and, normally, the unit requires no servicing. If there is evidence of loss of oil through the seals, see your dealer. Loss of oil in the fluid drive will cause increased engine speed, as in the case of a slipping clutch.

FLUID-TORQUE DRIVE

Remove the filler plug at the side of the reservoir below the clutch housing and inspect the level of the oil in the fluid-torque drive after 25 hours of operation and after each 250 hours thereafter. If necessary, replenish with MOPAR Fluid Drive Fluid to bring oil level to the bottom of the filler plug opening.

After 500 hours of operation, drain and refill the assembly.

To drain the reservoir, remove the drain plug from the bottom of the reservoir.

To drain the fluid-torque drive unit, first remove the flywheel housing cover plate (at bottom), then remove the drain plug from the fluid-torque drive housing and allow the oil to drain. Rotate the unit one-half revolution and remove the opposite drain plug. Allow the remainder of the oil to drain. Install the two drain plugs, with new gaskets. To refill, remove the filler plug from the left side of the reservoir and fill the reservoir to the lower edge of the filler plug opening, with MOPAR Fluid Drive Fluid. Start the engine and run between 500 rpm and 700 rpm with the transmission in neutral to permit the fluid to fill the unit. With the engine running, continue adding fluid to the reservoir until the fluid level remains constant at the lower edge of the filler opening. Install the filler plug, with the gasket and install the cover plate on the engine flywheel housing.

To eliminate air bubbles from the fluid, lock the output shaft and again run the engine between 500 rpm and 700 rpm for not more than two minutes and inspect the fluid level. Refill if necessary and install the filler plug. The capacity of the fluid-torque drive is 10 1/2 quarts.

5-SPEED TRANSMISSION - EITHER TYPE

Remove the filler plug and inspect the level of the lubricant after each 50 hours of operation. Level should be at bottom of the filler plug opening. Replenish, if necessary, with fluid gear lubricant of the proper grade. For temperatures above -10° F., use SAE 90 and for temperatures below -10° F., use SAE 80. If SAE 80 is not available, use a blend of four parts SAE 90 to one part SAE 10-W engine oil. Do not use a lubricant heavier than SAE 90. Drain and refill the transmission prior to anticipated temperature change or after each 800 hours of operation. The capacity of the regular 5-speed transmission is 9 pints, and that of the 5-speed heavy duty transmission is 16 pints. If the unit is equipped with a power take-off, add 1 1/2 pints.

HYDRAULICALLY-OPERATED TRANSMISSION

A new hydraulically-operated transmission is filled at the factory with a special lubricant similar in appearance to SAE 10-W engine oil, but containing certain additives to aid in proper breaking-in of a new unit. This oil should not be replaced before 250 hours of operation. If oil must be added before 250 hours, add SAE 10-W engine oil to keep the level even with the filler plug opening. If for any reason, the transmission must be drained before 250 hours, the original oil should be saved, filtered and returned to the repaired or replaced unit. The capacity of this transmission is 3 pints.

POWER TAKE-OFF, WITH HEAVY DUTY CLUTCH

Three lubrication fittings are provided for this assembly, one or two on the side of the housing and one at the end of the shaft. On some units, the fitting for the clutch release bearing is inside the housing, accessible by removing a small plate at the left side of the housing. See Figure 3. For some types of installation, the drive shaft must be lubricated from the side, rather than the end. In such case, remove the small plug from the shaft and install a fitting in its place. Remove the fitting from the end of the shaft and replace with the plug. Lubricate the clutch release daily with general purpose grease, and lubricate the drive shaft after each 50 hours of operation.

Maintenance

MAINTENANCE SCHEDULES

DAILY

1. Check level of oil in crankcase and add oil if necessary to bring level to "FULL" mark on indicator. See Lubrication Section for oil recommendations.
2. Check cooling system and add clean water or anti-freeze as required.
3. If the engine is operated under extremely dusty conditions, check the carburetor air cleaner and the two crankcase ventilation air cleaners for accumulation of oil and dirt and service as required. See Lubrication Section.
4. If the unit is equipped with a power take-off, lubricate the clutch release bearing.
5. Check oil level in governor housing, and replenish, if necessary (Pierce or Hoof governor).

AFTER 25 HOURS OF OPERATION

Lubricate and service as specified for "Daily" and perform the following additional operations:

1. Lubricate the water pump.
2. Check the level of the fluid in the fluid-torque drive, if unit is so equipped.
3. Adjust fan and generator belts.

EVERY 50 HOURS OF OPERATION

In addition to the operations listed under "Daily" and "After 25 Hours of Operation", perform the following operations:

1. Drain the engine crankcase and refill with recommended grade of oil. See Lubrication Section.
2. Clean and service the carburetor air cleaner and the crankcase ventilation air cleaners as described in the Lubrication Section.
3. Lubricate the generator. See Lubrication Section.
4. Lubricate the distributor (oil cup).
5. Check the lubricant in the transmission.
6. Lubricate the power take-off drive shaft bearings.
7. Check the electrolyte in battery.

EVERY 100 HOURS OF OPERATION

1. Replace filter element in oil filter.

EVERY 250 HOURS OF OPERATION

1. Clean and adjust contact points in distributor (.015 to .018 inch).
2. Lubricate distributor cam wick.
3. Check spark plugs for fouling and for proper gap (.035 inch).
4. Check ignition timing. See Adjustment Section.
5. Check carburetor adjustment. See Adjustment Section.
6. Inspect all wiring for loose connections and worn or broken insulation. Clean the battery terminals and coat with vaseline.
7. Clean the engine thoroughly.
8. Inspect fluid level in Fluid-Torque Drive.
9. Drain and refill transmission (hydraulically operated).

EVERY 500 HOURS OF OPERATION

1. Drain and refill transmission (5-speed).
2. Drain and refill Fluid-Torque Drive.

Adjustments

ELECTRICAL SYSTEM

DISTRIBUTOR CONTACT POINTS (Figure 20). In order to maintain efficient operation, the contact points in the distributor must be adjusted properly. There are two sets of points, the maker points and the breaker points.

To adjust either set of points, remove the distributor cap, rotate the distributor shaft until a high spot of the cam contacts the rubbing block for the points. Loosen the lock screw just enough to permit the stationary plate to be moved. Insert a screwdriver blade in the triangular space and rotate the blade against the stationary plate to open or close the point gap. Clearance between the points should be from .015 to .018 inch, as measured with a clean feeler gauge. Tighten the lock screw.

Rotate the distributor shaft until the high spot of the cam contacts the rubbing block of the opposite points and adjust in the same manner.

If the cam appears dry, apply a small amount of MOPAR cam lubricant (Part No. 1473595) to the rubbing blocks.

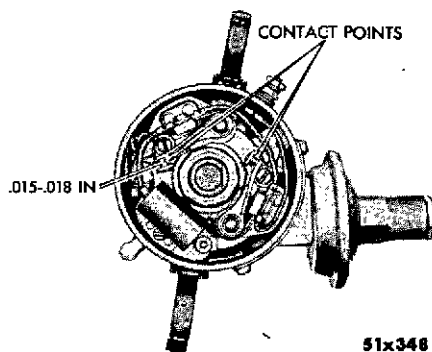

Figure 20 - Distributor Contact Point Adjustment

DISTRIBUTOR TIMING

GENERAL. Before adjusting ignition timing, be sure that the distributor is properly installed and that the points have been set to open .015 to .018 inch. Then determine the timing position; under ideal conditions, ignition should occur at top dead center, but if spark ping is excessive, ignition should be retarded, to occur at not more than 4 degrees after top dead center. In high altitudes, or in low altitudes when a premium grade of fuel is used, ignition may be advanced to occur at not more than 4 degrees before top dead center.

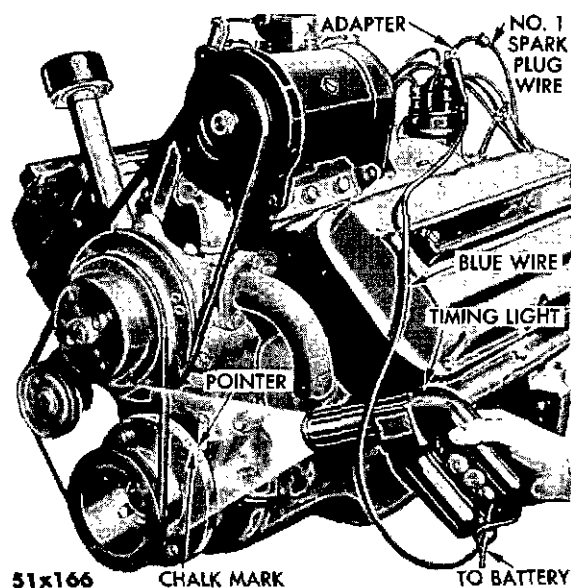

Figure 21 - Timing Distributor with Timing Light

PROCEDURE A (with timing light tool C-693) (figure 21). First, place a chalk mark on the vibration damper at the register mark indicating the desired timing point (TDC, or the correct number of degrees BTDC or ATDC). Remove the No. 1 spark plug wire from the distributor and insert it in the female end of the adapter tool

C-3066. Insert the male end of the adapter in the No. 1 distributor tower. Connect the blue wire of the timing lamp to the female end of the adapter tool, the wire with the black insulator to the negative battery terminal and the wire with the red insulator to the positive battery terminal. Start the engine and run at idle speed until normal operating temperature is reached. Observe the flash of the timing light, which should occur when the chalk mark on the vibration damper is exactly opposite the pointer on the engine block. If it does not, loosen the distributor clamp bolt and rotate the distributor clockwise or counter-clockwise until the specified timing is obtained; then tighten the clamp bolt. Accelerate the engine and observe the timing light. As engine speed increases, the timing light should indicate a gradual spark advance.

PROCEDURE B (with a test lamp). Rotate the engine in operation direction until the correct register mark on the vibration damper is opposite the pointer on the engine block. Connect a test lamp (6-volt) in series between the distributor primary lead and the negative terminal of the battery. Turn on the ignition. Loosen the distributor clamp bolt and turn the distributor clockwise until the test lamp lights. Then turn it counter-clockwise until the instant the light goes out. Then tighten the distributor clamp bolt.

SPARK PLUGS. Spark plugs used in the industrial engine are the Resistor type (4S165), size 14 mm. The gap should be .035 inch, \pm .001 inch. Be sure to use the correct type of spark plug, as this is a high compression engine.

CARBURETOR ADJUSTMENT

Before attempting any adjustment of the carburetor, check the following items:

- (1) Spark plugs. See that plugs are correct type, clean, and have correct gap (.035 inch).
- (2) Distributor Points. See that both sets of points are clean, in good condition and properly set (.015 to .018 inch).

(3) All high tension terminals. See that terminals are making good contact at plugs and at distributor cap.

(4) Compression should be approximately even in all cylinders.

(5) Carburetor should be clean and in good condition and firmly attached to the manifold with no air leaks.

(6) The manifold heat control valve should be free and functioning correctly.

Make initial adjustment of idle needle valves by turning both valves clockwise carefully until seated. Do not force the valves against the seats. Then back each valve out one full turn. Start the engine and run until normal operating temperature is reached. The choke valve should now be in the fully open position. Turn each needle valve $1/8$ turn clockwise (leaner).

Observe the performance of the engine for slightly increased speed, smoother running and absence of fluffs at the exhaust.

If these improvements are noticed, try turning the valves another $1/8$ turn clockwise and observe as before. If further improvement is noted, the adjustment is correct, but if the engine stalls or misses, turn the valves counter-clockwise until the engine runs smoothly and at the best idling speed.

Try to adjust both needle valves the same within $1/8$ turn. The best performance is usually obtained with both valves between $3/4$ and $1\ 1/4$ turns open.

Other carburetor adjustments are made during assembly of the carburetor and require the use of special tools. They should be made only by an experienced carburetor mechanic.

GOVERNOR ADJUSTMENT

DRIVE BELT (Pierce or Hoof). To tighten the governor drive belt, loosen the governor mounting bolts and move the governor away from the engine enough to establish tension on the belt, then tighten the mounting bolts.

THROTTLE TO GOVERNOR ROD (Pierce). Install the lower ball joint of the rod in the upper hole of the governor operating lever.

Turn the low speed stop screw in to hold the governor lever in the open position, and hold the carburetor throttle lever open against the stop. Adjust the length of the rod so that the upper ball joint just fits into the tapped hole in the throttle lever. Test the operation of the rod for friction or excessive free play, and adjust, if necessary, at the ball joint.

THROTTLE TO GOVERNOR ROD (Hoof). Adjust the length of the rod so that the throttle lever on the carburetor contacts the stop just as the governor lever is at the wide open position. Test the operation of the rod for friction or excessive free play and adjust, if necessary, at the ball joint.

ADJUST TO ELIMINATE SURGE (Pierce). Select an engine speed at the low point of the range at which the governor is to operate and set the speed change lever to obtain this speed. If a no-load surge is encountered at this point, turn the surge adjusting screw in slowly until the surge disappears. Under no circumstances should the surge screw be turned in far enough to increase the no-load speed of the engine more than 25 rpm.

To correct surge under load, loosen the spring eye-bolt lock nut and turn the eye-bolt to decrease spring tension. Then tighten the lock nut.

ADJUST TO ELIMINATE SURGE (Hoof). To correct no-load surge, loosen the adjusting screw lock nut and turn the adjusting screw in until the surge disappears, but not far enough to increase no-load engine speed more than a few rpm.

To correct surge under engine load, loosen the spring lever clamp screw and move the spring lever forward until the eye of the lever is clear of the front of the governor lever. Tighten the spring lever clamp screw.

ADJUST GOVERNED SPEED OF ENGINE (Pierce). Move the speed change lever in clockwise direction until an engine speed midway in the desired range is obtained. Load and unload the engine and

observe the variation in rpm between no-load and full-load speeds. If variation is excessive, adjust the spring eye-bolt to increase spring tension and move the speed change lever counter-clockwise until the previously selected speed is obtained. Check the results again and repeat the process until the desired regulation is obtained. Next, move the speed change lever clockwise until the top load is reached and set the maximum speed adjusting screw to limit lever travel at this point. Then move the speed change lever counter-clockwise until the lowest speed in the range is reached and set the minimum speed adjusting screw to limit lever travel at this point. Tighten all lock nuts after making the adjustments.

ADJUST VARIABLE SPEED LEVER TRAVEL (Some Hoof Models).

Test the engine rpm's at high and low speeds in the desired range and set the adjusting screws to limit travel of the variable speed lever in that range. The maximum speed adjusting screw is located at the right of the lever and the minimum speed adjusting screw is at the left. Both screws are provided with lock nuts to hold the adjustment.

ADJUST CONTROL (Hoof). Sharpness of governor control may be increased by varying the tension of the governor spring. In general, increasing the spring tension sharpens the control. However, for very low speeds, it may be advisable to reduce spring tension. To increase spring tension, loosen the spring lever clamp nut and move the spring lever counter-clockwise. To decrease tension, move the lever clockwise. The position of the lever will be determined by the speed range at which greatest accuracy is desired. For middle speed ranges, the spring lever should be approximately vertical when the throttle valve is wide open. Tighten the spring lever clamp screw after adjusting the lever. Check the spring deflection; normal deflection for wide range of speed is $\frac{3}{8}$ inch with the throttle wide open and the eye of the spring lever in alignment with the front edge of the operating lever. If spring deflection exceeds $\frac{3}{4}$ inch when the spring lever is vertical, or nearly so, hook the spring in the end hole in the spring clip, or move the spring clip

to the next anchor pin hole on the right. (The spring clip is secured to the anchor pin with a cotter pin).

STARTER PINION ADJUSTMENT

GENERAL. When the starter solenoid is energized to engage the starter pinion, there should be .015 to .030 inch clearance between the pinion and the pinion thrust washer, in order to prevent binding or jamming of the pinion. An accurate measurement of clearance can be made only when the solenoid is holding the pinion in the engaged position. For this reason, do not rely on a measurement made when holding the solenoid plunger in by hand.

PROCEDURE. Remove the starter from the engine. Detach the strap connecting the solenoid to the starting motor terminal. Connect a 6-volt battery to the frame of the starting motor (ground) and to the starter solenoid battery terminal. Connect a jumper wire from the solenoid relay ground terminal to the starter frame. Connect another jumper wire from the starter switch terminal of the relay to the solenoid battery terminal. (This wire energizes the solenoid). Push the solenoid plunger into the engaged position; the energized solenoid will hold the plunger in position. Measure the clearance between the pinion and the pinion thrust washer. If the clearance is not within the specified limits (.015 to .030 inch), remove the cotter pin and link pin that attaches the pinion yoke to the solenoid plunger and turn the plunger stud in or out the required distance to provide proper clearance.

FAN BELT ADJUSTMENT

Fan belt adjustment is made by moving the idler pulley to loosen or tighten the belt. To make the adjustment, loosen the idler pulley bracket bolt and position the idler pulley so that there is 1/2 inch

of slack when pressure is applied between the pulleys. Tighten the idler pulley bracket bolt after making the adjustment.

GENERATOR BELT ADJUSTMENT

Generator belt adjustment is made by means of the generator adjusting strap. To make the adjustment, loosen the generator mounting bolts and the adjusting strap screw. Then position the generator so that there is 3/4 inch slack when pressure is applied to the belt. Tighten the adjusting strap screw and the generator mounting bolts after making the adjustment.

POWER TAKE-OFF, WITH HEAVY DUTY CLUTCH

GENERAL. The clutch must be properly adjusted to prevent slippage, which causes rapid wear of the clutch facings and distortion of the plates. Frequency of adjustment is determined by the amount and nature of the load. Heavy or shock loads necessitate frequent clutch adjustment to compensate for wear.

PROCEDURE. Place the shifting lever in released position and remove the adjustment cover from the housing. See Figure 3. Release the adjustment nut lock and with a long screwdriver or rod inserted in a notch in the nut, turn the nut in a clockwise direction until firm pressure is required to engage the clutch. To keep the clutch from turning with the adjusting nut, apply pressure on the shifting lever while turning the nut. Be sure the lock engages to hold the adjustment.

Preparation for Storage

When the engine is to be stored or removed from operation for an extended period of time, the following precautions should be taken to prevent rust accumulation, corrosion of bearing and mating surfaces within the engine, and gum formation in the fuel system:

1. Drain the lubricating oil from the engine and add 2 1/2 quarts of Rust Preventive Oil which may be obtained from a reliable oil company.

2. Drain the cooling system, add MOPAR RUST RESISTOR and fill with clean water.

3. Run the engine at idle speed for three or four minutes (avoid overheating) to:

(a) Circulate the Rust Resistor to form a protective film in the water jackets and in the radiator or heat exchanger.

(b) Distribute the Rust Preventive Oil throughout the internal parts of the engine.

4. Remove the top of the carburetor air cleaner and with the engine running at approximately 1000 rpm, pour 1/2 pint of Rust Preventive Oil through the carburetor air intake. Turn off the ignition as soon as the 1/2 pint of oil has been drawn into the combustion chamber.

NOTE: If the engine will not run under its own power, turn it over several times with the starting motor to distribute the oil.

5. Drain the Rust Preventive Oil from the crankcase.

6. Remove the spark plugs and pour one ounce of rust preventive oil into each spark plug opening. Turn the engine over four or five revolutions with the starting motor and install the plugs.

7. Drain the cooling system (one drain cock in radiator, one at each side of engine block).

8. Drain the fuel system tank, fuel pump and filter and carburetor. Operate the carburetor throttle lever several times to empty the accelerator pump system.

9. Remove the carburetor air cleaner, the oil filler cap air cleaner and the outlet ventilator pipe air cleaner. Seal the openings with masking or adhesive tape. Also, seal the exhaust outlet opening in the exhaust manifold or exhaust pipe.

10. Replace the element in the oil filter after cleaning the filter housing.

11. Remove the storage battery and store in a cool, dry place. Replenish the water in the battery cells to cover the plates $\frac{3}{8}$ inch. See that the battery is fully charged and keep it fully charged during the idle period.

12. Protect the engine with a waterproof cover if it is exposed to the weather.

13. Make periodic inspections to see that the engine is properly stored and that all seals are intact.

