

ENGINE

TABLE OF CONTENTS

	page		page
2.5L ENGINE.....	1	4.0L ENGINE.....	61

2.5L ENGINE

TABLE OF CONTENTS

	page		page
DESCRIPTION AND OPERATION			
ENGINE.....	2	REPAIR DAMAGED OR WORN THREADS.....	27
LUBRICATION SYSTEM.....	2	SERVICE ENGINE ASSEMBLY (SHORT BLOCK)....	27
CYLINDER BLOCK.....	5	HYDROSTATIC LOCK.....	27
CYLINDER HEAD.....	5	ENGINE OIL SERVICE.....	27
CRANKSHAFT.....	5	REMOVAL AND INSTALLATION	
PISTON AND CONNECTING ROD.....	6	ENGINE MOUNTS—FRONT.....	29
CAMSHAFT.....	6	ENGINE MOUNT—REAR.....	30
ROCKER ARM.....	6	ENGINE.....	31
VALVES.....	6	INTAKE MANIFOLD.....	33
VALVE SPRING.....	7	EXHAUST MANIFOLD.....	35
CYLINDER HEAD COVER.....	7	CYLINDER HEAD COVER.....	35
HYDRAULIC TAPPET.....	7	ROCKER ARMS AND PUSH RODS.....	36
VALVE GUIDE.....	7	VALVE SPRING AND SEAL.....	37
OIL PAN.....	7	CYLINDER HEAD.....	38
VALVE STEM SEAL.....	8	CYLINDER HEAD.....	40
INTAKE MANIFOLD.....	8	HYDRAULIC TAPPETS.....	40
EXHAUST MANIFOLD.....	8	VIBRATION DAMPER.....	41
DIAGNOSIS AND TESTING			
ENGINE DIAGNOSIS—INTRODUCTION.....	8	TIMING CASE COVER OIL SEAL.....	41
SERVICE DIAGNOSIS—PERFORMANCE.....	9	TIMING CASE COVER.....	42
SERVICE DIAGNOSIS—MECHANICAL.....	10	TIMING CHAIN AND SPROCKETS.....	43
INTAKE MANIFOLD LEAKAGE DIAGNOSIS.....	13	CAMSHAFT.....	44
CYLINDER COMPRESSION PRESSURE TEST ..	13	CAMSHAFT PIN REPLACEMENT.....	45
ENGINE CYLINDER HEAD GASKET FAILURE		CAMSHAFT BEARINGS.....	47
DIAGNOSIS.....	13	CRANKSHAFT MAIN BEARINGS.....	47
CYLINDER COMBUSTION PRESSURE		OIL PAN.....	49
LEAKAGE TEST.....	13	OIL PUMP.....	50
ENGINE OIL LEAK INSPECTION.....	14	PISTON AND CONNECTING ROD.....	51
ENGINE OIL PRESSURE.....	15	REAR MAIN OIL SEAL.....	52
SERVICE PROCEDURES			
VALVE TIMING.....	15	DISASSEMBLY AND ASSEMBLY	
VALVE, GUIDE AND SEAL.....	15	CYLINDER BLOCK.....	53
PISTON—FITTING.....	17	CLEANING AND INSPECTION	
PISTON RING—FITTING.....	18	ROCKER ARMS AND PUSH RODS.....	53
CONNECTING ROD BEARINGS—FITTING.....	21	ENGINE CYLINDER HEAD.....	54
FITTING CRANKSHAFT MAIN BEARINGS.....	23	CYLINDER BLOCK.....	54
FORM-IN-PLACE GASKETS.....	25	SPECIFICATIONS	
ENGINE PERFORMANCE.....	26	ENGINE SPECIFICATIONS.....	55
HONING CYLINDER BORES.....	26	SPECIFICATIONS—TORQUE.....	59
		SPECIAL TOOLS	
		2.5L ENGINE SPECIAL TOOLS.....	60

DESCRIPTION AND OPERATION

ENGINE

DESCRIPTION

The 2.5 liter (150 CID) four-cylinder engine is an In-line, lightweight, overhead valve engine.

This engine is designed for unleaded fuel. The engine cylinder head has dual quench-type combustion chambers that create turbulence and fast burning of the air/fuel mixture. This results in good fuel economy.

The cylinders are numbered 1 through 4 from front to rear. The firing order is 1-3-4-2 (Fig. 1).

The crankshaft rotation is clockwise, when viewed from the front of the engine. The crankshaft rotates within five main bearings and the camshaft rotates within four bearings.

The engine Build Date Code is located on a machined surface on the right side of the cylinder block between the No.3 and No.4 cylinders (Fig. 2).

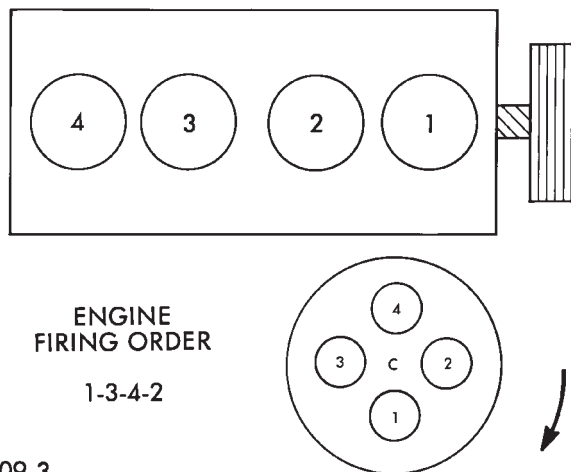

J9209-3

Fig. 1 Engine Firing Order

The digits of the code identify:

- 1st Digit—The year (8 = 1998).
- 2nd & 3rd Digits—The month (01 - 12).
- 4th & 5th Digits—The engine type/fuel system/compression ratio (HX = A 2.5 liter (150 CID) 9.1:1 compression ratio engine with a multi-point fuel injection system).

- 6th & 7th Digits—The day of engine build (01 - 31).

FOR EXAMPLE: Code * 801HX23 * identifies a 2.5 liter (150 CID) engine with a multi-point fuel injection system, 9.1:1 compression ratio and built on January 23, 1998.

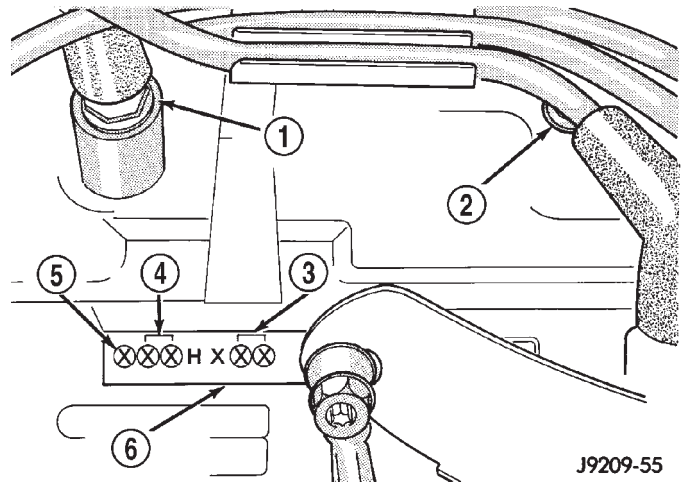

J9209-55

Fig. 2 Build Date Code Location

- 1 - NO. 4 CYLINDER
- 2 - NO. 3 CYLINDER
- 3 - DAY
- 4 - MONTH
- 5 - YEAR
- 6 - MACHINED SURFACE

LUBRICATION SYSTEM

DESCRIPTION

A gear-type positive displacement pump is mounted at the underside of the block opposite the No. 4 main bearing.

OPERATION

The pump draws oil through the screen and inlet tube from the sump at the rear of the oil pan. The oil is driven between the drive and idler gears and pump body, then forced through the outlet to the block. An oil gallery in the block channels the oil to the inlet side of the full flow oil filter. After passing through the filter element, the oil passes from the center outlet of the filter through an oil gallery that channels the oil up to the main gallery which extends the entire length of the block.

Galleries extend downward from the main oil gallery to the upper shell of each main bearing. The crankshaft is drilled internally to pass oil from the main bearing journals (except number 4 main bearing journal) to the connecting rod journals. Each connecting rod bearing cap has a small squirt hole, oil passes through the squirt hole and is thrown off as the rod rotates. This oil throwoff lubricates the camshaft lobes, distributor drive gear, cylinder walls, and piston pins.

The hydraulic valve tappets receive oil directly from the main oil gallery. Oil is provided to the camshaft bearing through galleries. The front camshaft bearing journal passes oil through the camshaft

DESCRIPTION AND OPERATION (Continued)

sprocket to the timing chain. Oil drains back to the oil pan under the number one main bearing cap.

The oil supply for the rocker arms and bridged pivot assemblies is provided by the hydraulic valve tappets which pass oil through hollow push rods to a

hole in the corresponding rocker arm. Oil from the rocker arm lubricates the valve train components, then passes down through the push rod guide holes in the cylinder head past the valve tappet area, and returns to the oil pan.

DESCRIPTION AND OPERATION (Continued)

CYLINDER BLOCK

DESCRIPTION

The cylinder block is a cast iron inline four cylinder design. The cylinder block is drilled forming galleries for both oil and coolant.

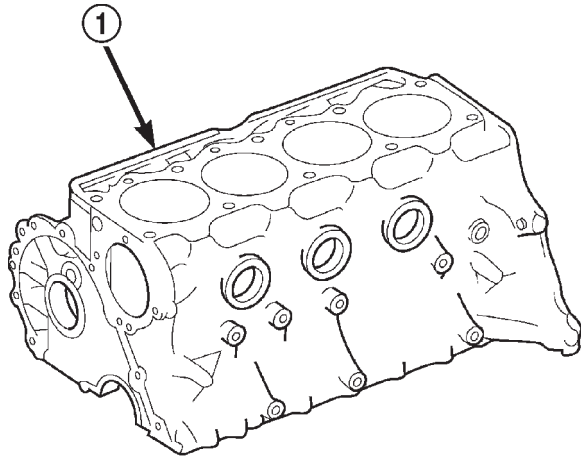

80be4676

Fig. 3 Cylinder Block—2.5L

1 - CYLINDER BLOCK

CYLINDER HEAD

DESCRIPTION

The cylinder head is made of cast iron containing eight valves made of chrome plated heat resistant steel, valve stem seals, springs, retainers and keepers. The cylinder head, valve seats and guides can be resurfaced for service purposes.

The cylinder head uses dual quench-type design combustion chambers which cause turbulence in the cylinders allowing faster burning of the air/fuel mixture, resulting in better fuel economy.

The valve guides are integral to the cylinder head. They are not replaceable. However, they are serviceable.

CRANKSHAFT

DESCRIPTION

The crankshaft is constructed of nodular cast iron.

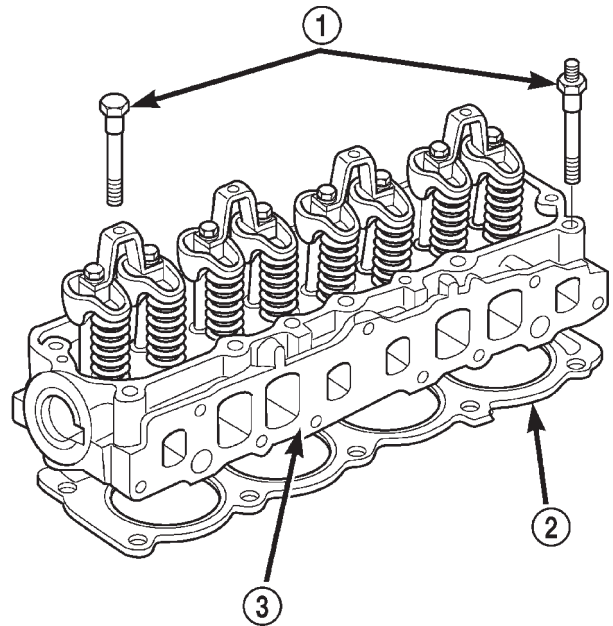

80be4674

Fig. 4 Cylinder Head

- 1 - CYLINDER HEAD BOLTS
2 - CYLINDER HEAD GASKET
3 - CYLINDER HEAD

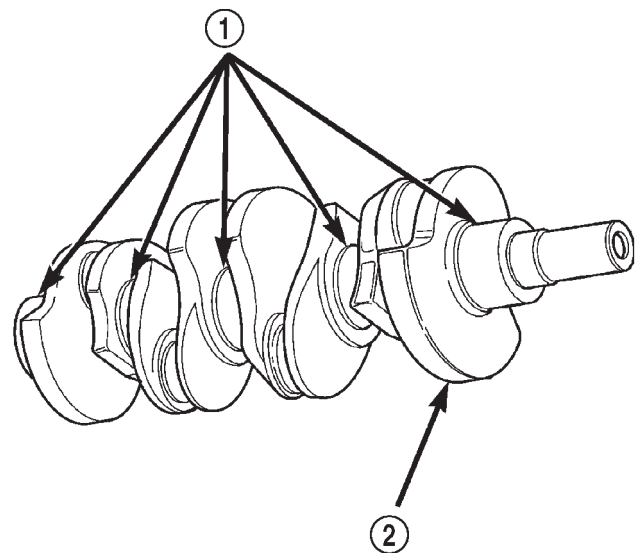

80bcea52

Fig. 5 Crankshaft—Typical

- 1 - MAIN BEARING JOURNALS
2 - COUNTER BALANCE WEIGHTS

DESCRIPTION AND OPERATION (Continued)

PISTON AND CONNECTING ROD

DESCRIPTION

The pistons are made of a high strength aluminum alloy, the piston skirts are coated with a solid lubricant (Molykote) to reduce friction and provide scuff resistance. The connecting rods are made of cast iron.

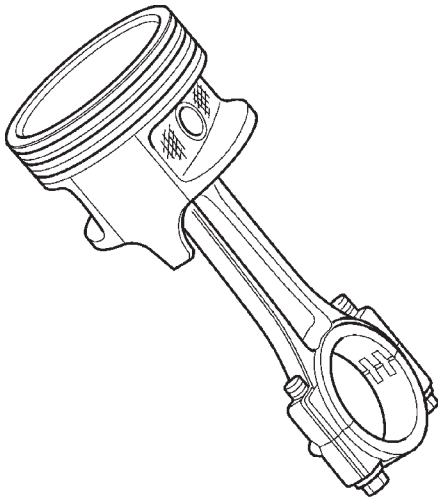

80bcea5c

Fig. 6 Piston and Connecting Rod Assembly

CAMSHAFT

DESCRIPTION

The camshaft is made of cast iron with eight machined lobes and four bearing journals.

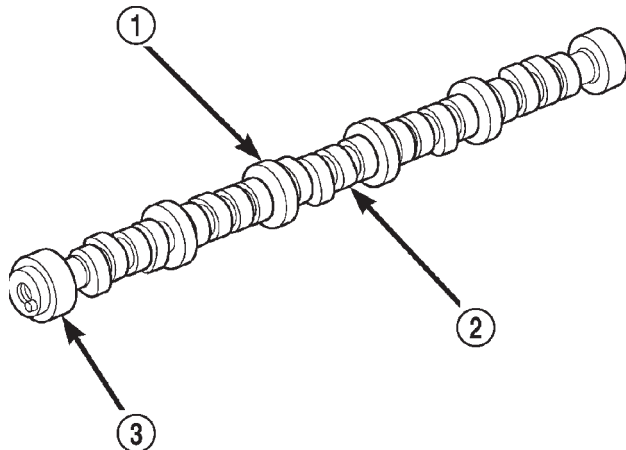

80be4673

Fig. 7 Camshaft—Typical

- 1 - CAMSHAFT
- 2 - LOBES
- 3 - BEARING JOURNAL

OPERATION

When the camshaft rotates, the lobes actuate the tappets and push rods forcing upward on the rocker arms which applies downward force on the valves.

ROCKER ARM

DESCRIPTION

The rocker arms are made of stamped steel and have a operational ratio of 1.6:1.

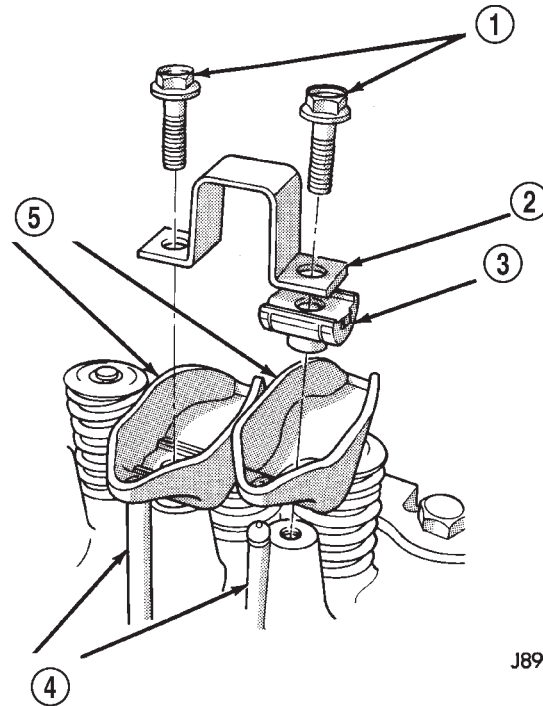

J8909-8

Fig. 8 Rocker Arms—Typical

- 1 - CAPSCREWS
- 2 - BRIDGE
- 3 - PIVOT ASSEMBLY
- 4 - PUSH RODS
- 5 - ROCKER ARMS

OPERATION

When the push rods are forced upward by the camshaft lobes the push rod presses upward on the rocker arms, the rocker arms pivot, forcing downward pressure on the valves forcing the valves to move downward and off from their seats.

VALVES

DESCRIPTION

The valves are made of heat resistant steel and have chrome plated stems to prevent scuffing. All valves use three bead lock keepers to retain the valve spring and promote valve rotation (Fig. 9).

DESCRIPTION AND OPERATION (Continued)

VALVE SPRING

DESCRIPTION

The valve springs are made of high strength chrome silicon steel. The springs are common for both intake and exhaust valves.

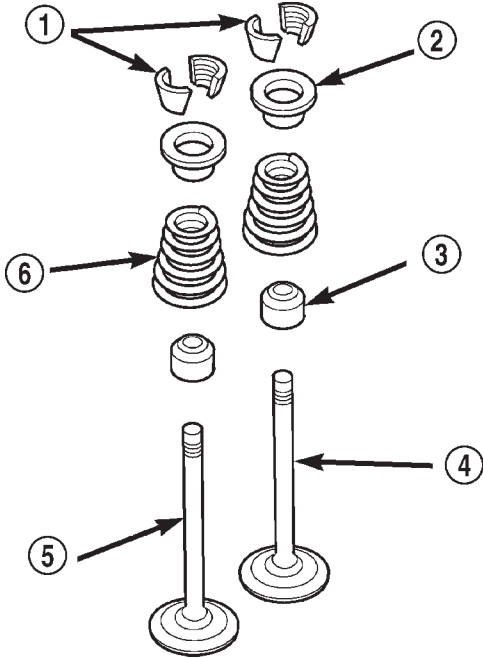

80b7704b

Fig. 9 Valve and Keeper Configuration 2.5L Engine

- 1 - VALVE LOCKS (3-BEAD)
- 2 - RETAINER
- 3 - VALVE STEM OIL SEAL
- 4 - INTAKE VALVE
- 5 - EXHAUST VALVE
- 6 - VALVE SPRING

CYLINDER HEAD COVER

DESCRIPTION

The cylinder head cover is made of die cast aluminum and incorporates the Crankcase Ventilation (CCV) Hoses and the oil fill opening.

HYDRAULIC TAPPET

DESCRIPTION

Valve lash is controlled by hydraulic tappets located inside the cylinder block, in tappet bores above the camshaft.

VALVE GUIDE

DESCRIPTION

The valve guides are integral to the cylinder head. They are not replaceable. However, they are serviceable.

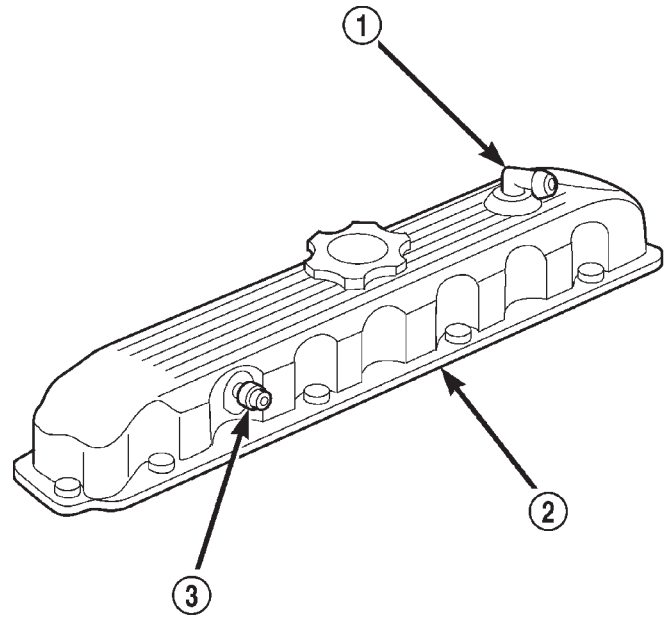

80be4679

Fig. 10 Cylinder Head Cover

- 1 - AIR INLET FITTING
- 2 - CYLINDER HEAD COVER
- 3 - FIXED ORIFICE FITTING

OIL PAN

DESCRIPTION

The oil pan is made of stamped steel. The oil pan gasket is a one piece steel backbone silicone coated gasket.

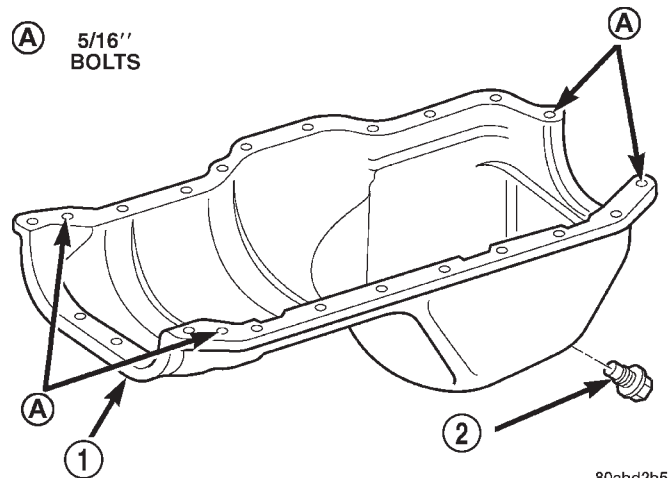

80abd2b5

Fig. 11 Oil Pan

- 1 - OIL PAN
- 2 - OIL PAN DRAIN PLUG

DESCRIPTION AND OPERATION (Continued)

VALVE STEM SEAL

DESCRIPTION

The valve stem seals are made of rubber and incorporate a garter spring to maintain consistent lubrication control (Fig. 9).

INTAKE MANIFOLD

DESCRIPTION

The intake manifold is made of cast aluminum and uses seven bolts to mount to the cylinder head. This mounting style improves sealing and reduces the chance of leaks.

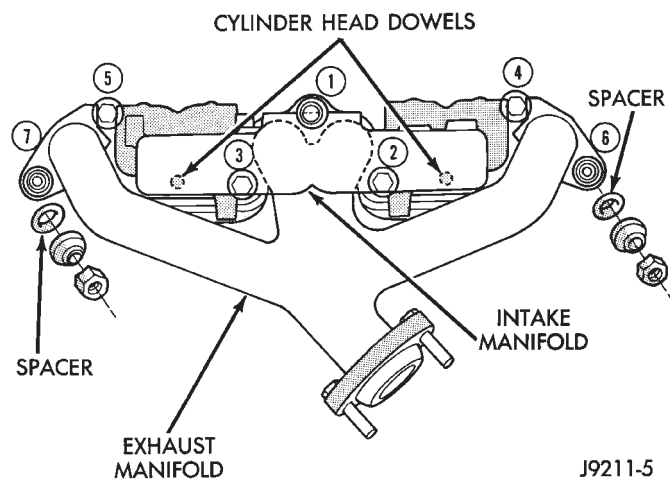

Fig. 12 Intake and Exhaust Manifold

EXHAUST MANIFOLD

DESCRIPTION

The exhaust manifold is log style and is made of high silicon molybdenum cast iron. The exhaust manifold shares a common gasket with the intake manifold. The exhaust manifold also incorporates a ball flange outlet for improved sealing and strain free connections (Fig. 12).

DIAGNOSIS AND TESTING

ENGINE DIAGNOSIS—INTRODUCTION

Engine diagnosis is helpful in determining the causes of malfunctions not detected and remedied by routine maintenance.

These malfunctions may be classified as either performance (e.g., engine idles rough and stalls) or mechanical (e.g., a strange noise).

Refer to the Service Diagnosis—Performance chart and the Service Diagnosis—Mechanical chart for possible causes and corrections of malfunctions. Refer to Group 14, Fuel System for the fuel system diagnosis.

Additional tests and diagnostic procedures may be necessary for specific engine malfunctions that can not be isolated with the Service Diagnosis charts. Information concerning additional tests and diagnosis is provided within the following diagnosis:

- Cylinder Compression Pressure Test.
- Cylinder Combustion Pressure Leakage Test.
- Engine Cylinder Head Gasket Failure Diagnosis.
- Intake Manifold Leakage Diagnosis.

DIAGNOSIS AND TESTING (Continued)

SERVICE DIAGNOSIS—PERFORMANCE

ENGINE PERFORMANCE DIAGNOSIS CHART

CONDITION	POSSIBLE CAUSES	CORRECTION
ENGINE WILL NOT CRANK	<ol style="list-style-type: none"> 1. Weak or dead battery 2. Corroded or loose battery connections 3. Faulty starter or related circuit(s) 4. Siezed accessory drive component 5. Engine internal mechanical failure or hydro-static lock 	<ol style="list-style-type: none"> 1. Charge/Replace Battery. Refer to Group 8A, Battery, for correct procedures. Check charging system. Refer to Group 8C, Charging Systems, for correct procedures. 2. Clean/tighten suspect battery/ starter connections 3. Check starting system. Refer to Group 8B, Starting Systems, for correct diagnostics/procedures 4. Remove accessory drive belt and attempt to start engine. If engine starts, repair/replace siezed component. 5. Refer to Group 9, Engine, for correct diagnostics/procedures
ENGINE CRANKS BUT WILL NOT START	<ol style="list-style-type: none"> 1. No spark 2. No fuel 3. Low or no engine compression 	<ol style="list-style-type: none"> 1. Check for spark. Refer to Group 8D, Ignition System, for correct procedures. 2. Perform fuel pressure test, and if necessary, inspect fuel injector(s) and driver circuits. Refer to Group 14, Fuel System, for correct procedures. 3. Perform cylinder compression pressure test. Refer to Group 9, Engine, for correct procedures.
ENGINE LOSS OF POWER	<ol style="list-style-type: none"> 1. Worn or burned distributor rotor 2. Worn distributor shaft 3. Worn or incorrect gapped spark plugs 4. Dirt or water in fuel system 5. Faulty fuel pump 6. Incorrect valve timing 7. Blown cylinder head gasket 8. Low compression 9. Burned, warped, or pitted valves 10. Plugged or restricted exhaust system 11. Faulty ignition cables 	<ol style="list-style-type: none"> 1. Install new distributor rotor 2. Remove and repair distributor (Refer to group 8D, Ignition System) 3. Clean plugs and set gap. (Refer to group 8D, Ignition System) 4. Clean system and replace fuel filter 5. Install new fuel pump 6. Correct valve timing 7. Install new cylinder head gasket 8. Test cylinder compression 9. Install/Reface valves as necessary 10. Install new parts as necessary 11. Replace any cracked or shorted cables

DIAGNOSIS AND TESTING (Continued)

CONDITION	POSSIBLE CAUSES	CORRECTION
	12. Faulty ignition coil	12. Test and replace, as necessary (Refer to Group 8D, ignition system)
ENGINE STALLS OR ROUGH IDLE	1. Carbon build-up on throttle plate 2. Engine idle speed too low 3. Worn or incorrectly gapped spark plugs 4. Worn or burned distributor rotor 5. Spark plug cables defective or crossed 6. Faulty coil 7. Intake manifold vacuum leak 8. EGR valve leaking or stuck open	1. Remove throttle body and de-carbon. (Refer to Group 14 for correct procedures) 2. Check Idle Air Control circuit. (Refer to Group 14, Fuel System) 3. Replace or clean and re-gap spark plugs (Refer to group 8D, Ignition System) 4. Install new distributor rotor 5. Check for correct firing order or replace spark plug cables. (Refer to Group 8D, Ignition System for correct procedures.) 6. Test and replace, if necessary (Refer to group 8D, Ignition System) 7. Inspect intake manifold gasket and vacuum hoses. Replace if necessary (Refer to Group 11, Exhaust System & Intake Manifold) 8. Test and replace, if necessary (Refer to group 25, Emission Control Systems)
ENGINE MISSES ON ACCELERATION	1. Worn or incorrectly gapped spark plugs 2. Spark plug cables defective or crossed 3. Dirt in fuel system 4. Burned, warped or pitted valves 5. Faulty coil	1. Replace spark plugs or clean and set gap. (Refer to group 8D, Ignition System) 2. Check Idle Air Control circuit. (Refer to Group 14, Fuel System) 3. Clean fuel system 4. Install new valves 5. Test and replace as necessary (refer to group 8D, Ignition System)

SERVICE DIAGNOSIS—MECHANICAL

ENGINE MECHANICAL DIAGNOSIS CHART

CONDITION	POSSIBLE CAUSES	CORRECTION
NOISY VALVES/LIFTERS	1. High or low oil level in crankcase 2. Thin or diluted oil 3. Low oil pressure	1. Check for correct oil level. Adjust oil level by draining or adding as needed 2. Change oil (Refer to Engine Oil Service in this group) 3. Check engine oil level. If ok, Perform oil pressure test. Refer to this group for engine oil pressure test/specifications

DIAGNOSIS AND TESTING (Continued)

CONDITION	POSSIBLE CAUSES	CORRECTION
	4. Dirt in tappets/lash adjusters 5. Bent push rod(s) 6. Worn rocker arms 7. Worn tappets/lash adjusters 8. Worn valve guides 9. Excessive runout of valve seats or valve faces	4. Clean/replace hydraulic tappets/lash adjusters 5. Install new push rods 6. Inspect oil supply to rocker arms and replace worn arms as needed 7. Install new hydraulic tappets/lash adjusters 8. Inspect all valve guides and replace as necessary 9. Grind valves and seats
CONNECTING ROD NOISE	1. Insufficient oil supply 2. Low oil pressure 3. Thin or diluted oil 4. Excessive connecting rod bearing clearance 5. Connecting rod journal out of round 6. Misaligned connecting rods	1. Check engine oil level. (Refer to group 0, Lubrication and Maintenance) 2. Check engine oil level. If ok, Perform oil pressure test. Refer to this group for engine oil pressure test/specifications 3. Change oil to correct viscosity. Refer to this group for correct procedure/engine oil specifications Measure bearings for correct clearance with plasti-gage. Repair as necessary 5. Replace crankshaft or grind journals 6. Replace bent connecting rods
MAIN BEARING NOISE	1. Insufficient oil supply 2. Low oil pressure 3. Thin or diluted oil 4. Excessive main bearing clearance 5. Excessive end play 6. Crankshaft main journal out of round or worn 7. Loose flywheel or torque converter	1. Check engine oil level. (Refer to group 0, Lubrication and Maintenance) 2. Check engine oil level. If ok, Perform oil pressure test. Refer to this group for engine oil pressure test/specifications 3. Change oil to correct viscosity. Refer to this group for correct procedure/engine oil specifications 4. Measure bearings for correct clearance. Repair as necessary 5. Check crankshaft thrust bearing for excessive wear on flanges 6. Grind journals or replace crankshaft 7. Inspect crankshaft, flexplate/flywheel and bolts for damage. Tighten to correct torque

DIAGNOSIS AND TESTING (Continued)

CONDITION	POSSIBLE CAUSES	CORRECTION
LOW OIL PRESSURE	<ol style="list-style-type: none"> 1. Low oil level 2. Faulty oil pressure sending unit 3. Clogged oil filter 4. Worn oil pump 5. Thin or diluted oil 6. Excessive bearing clearance 7. Oil pump relief valve stuck 8. Oil pump suction tube loose, broken, bent or clogged 9. Oil pump cover warped or cracked 	<ol style="list-style-type: none"> 1. Check oil level and fill if necessary 2. Install new sending unit 3. Install new oil filter 4. Replace worn gears or oil pump assy 5. Change oil to correct viscosity. Refer to this group for correct procedure/engine oil specifications 6. Measure bearings for correct clearance 7. Remove valve to inspect, clean and reinstall 8. Inspect suction tube and clean or replace if necessary 9. Install new oil pump
OIL LEAKS	<ol style="list-style-type: none"> 1. Misaligned or deteriorated gaskets 2. Loose fastener, broken or porous metal part 3. Front or rear crankshaft oil seal leaking 4. Leaking oil gallery plug or cup plug 	<ol style="list-style-type: none"> 1. Replace gasket 2. Tighten, repair or replace the part 3. Replace seal 4. Remove and reseal threaded plug. Replace cup style plug
EXCESSIVE OIL CONSUMPTION OR SPARK PLUGS OIL FOULED	<ol style="list-style-type: none"> 1. PCV System malfunction 2. Defective valve stem seal(s) 3. Worn or broken piston rings 4. Scuffed pistons/cylinder walls 5. Carbon in oil control ring groove 6. Worn valve guides 7. Piston rings fitted too tightly in grooves 	<ol style="list-style-type: none"> 1. Refer to group 25, Emission Control System for correct operation 2. Repair or replace seal(s) 3. Hone cylinder bores. Install new rings 4. Hone cylinder bores and replace pistons as required 5. Remove rings and de-carbon piston 6. Inspect/replace valve guides as necessary 7. Remove rings and check ring end gap and side clearance. Replace if necessary

DIAGNOSIS AND TESTING (Continued)

INTAKE MANIFOLD LEAKAGE DIAGNOSIS

An intake manifold air leak is characterized by lower than normal manifold vacuum. Also, one or more cylinders may not be functioning.

WARNING: USE EXTREME CAUTION WHEN THE ENGINE IS OPERATING. DO NOT STAND IN A DIRECT LINE WITH THE FAN. DO NOT PUT YOUR HANDS NEAR THE PULLEYS, BELTS OR THE FAN. DO NOT WEAR LOOSE CLOTHING.

- (1) Start the engine.
- (2) Spray a small stream of water at the suspected leak area.
- (3) If a change in RPM is observed the area of the suspected leak has been found.
- (4) Repair as required.

CYLINDER COMPRESSION PRESSURE TEST

The results of a cylinder compression pressure test can be utilized to diagnose several engine malfunctions.

Ensure the battery is completely charged and the engine starter motor is in good operating condition. Otherwise the indicated compression pressures may not be valid for diagnosis purposes.

- (1) Clean the spark plug recesses with compressed air.
- (2) Remove the spark plugs.
- (3) Secure the throttle in the wide-open position.
- (4) Disable the fuel system. (Refer to Group 14, Fuel System for the correct procedure)
- (5) Disconnect the ignition coil.
- (6) Insert a compression pressure gauge and rotate the engine with the engine starter motor for three revolutions.
- (7) Record the compression pressure on the 3rd revolution. Continue the test for the remaining cylinders.

Refer to Engine Specifications for the correct engine compression pressures.

ENGINE CYLINDER HEAD GASKET FAILURE DIAGNOSIS

A leaking engine cylinder head gasket usually results in loss of power, loss of coolant and engine misfiring.

An engine cylinder head gasket leak can be located between adjacent cylinders or between a cylinder and the adjacent water jacket.

- An engine cylinder head gasket leaking between adjacent cylinders is indicated by a loss of power and/or engine misfire.
- An engine cylinder head gasket leaking between a cylinder and an adjacent water jacket is indicated by coolant foaming or overheating and loss of coolant.

CYLINDER-TO-CYLINDER LEAKAGE TEST

To determine if an engine cylinder head gasket is leaking between adjacent cylinders; follow the proce-

dures outlined in Cylinder Compression Pressure Test. An engine cylinder head gasket leaking between adjacent cylinders will result in approximately a 50-70% reduction in compression pressure.

CYLINDER-TO-WATER JACKET LEAKAGE TEST

WARNING: USE EXTREME CAUTION WHEN THE ENGINE IS OPERATING. DO NOT STAND IN A DIRECT LINE WITH THE FAN. DO NOT PUT YOUR HANDS NEAR THE PULLEYS, BELTS OR THE FAN. DO NOT WEAR LOOSE CLOTHING.

Remove the radiator cap.

Start the engine and allow it to warm up until the engine thermostat opens.

If a large combustion/compression pressure leak exists, bubbles will be visible in the coolant.

If bubbles are not visible, install a radiator pressure tester and pressurize the coolant system.

If a cylinder is leaking combustion pressure into the water jacket, the tester pointer will pulsate with every combustion stroke of the cylinder.

CYLINDER COMBUSTION PRESSURE LEAKAGE TEST

The combustion pressure leakage test provides an accurate means for determining engine condition.

Combustion pressure leakage testing will detect:

- Exhaust and intake valve leaks (improper seating).
- Leaks between adjacent cylinders or into water jacket.

- Any causes for combustion/compression pressure loss.

(1) Check the coolant level and fill as required. **DO NOT** install the radiator cap.

(2) Start and operate the engine until it attains normal operating temperature, then turn the engine OFF.

(3) Remove the spark plugs.

(4) Remove the oil filler cap.

(5) Remove the air cleaner.

(6) Calibrate the tester according to the manufacturer's instructions. The shop air source for testing should maintain 483 kPa (70 psi) minimum, 1,379 kPa (200 psi) maximum and 552 kPa (80 psi) recommended.

(7) Perform the test procedures on each cylinder according to the tester manufacturer's instructions. While testing, listen for pressurized air escaping through the throttle body, tailpipe and oil filler cap opening. Check for bubbles in the radiator coolant.

All gauge pressure indications should be equal, with no more than 25% leakage.

FOR EXAMPLE: At 552 kPa (80 psi) input pressure, a minimum of 414 kPa (60 psi) should be maintained in the cylinder.

Refer to the Cylinder Combustion Pressure Leakage Test Diagnosis chart.

DIAGNOSIS AND TESTING (Continued)

CYLINDER COMBUSTION PRESSURE LEAKAGE DIAGNOSIS CHART

CONDITION	POSSIBLE CAUSE	CORRECTION
AIR ESCAPES THROUGH THROTTLE BODY	Intake valve bent, burnt, or not seated properly	Inspect valve and valve seat. Reface or replace, as necessary
AIR ESCAPES THROUGH TAILPIPE	Exhaust valve bent, burnt, or not seated properly	Inspect valve and valve seat. Reface or replace, as necessary
AIR ESCAPES THROUGH RADIATOR	Head gasket leaking or cracked cylinder head or block	Remove cylinder head and inspect. Replace defective part
MORE THAN 50% LEAKAGE FROM ADJACENT CYLINDERS	Head gasket leaking or crack in cylinder head or block between adjacent cylinders	Remove cylinder head and inspect. Replace gasket, head, or block as necessary
MORE THAN 25% LEAKAGE AND AIR ESCAPES THROUGH OIL FILLER CAP OPENING ONLY	Stuck or broken piston rings; cracked piston; worn rings and/or cylinder wall	Inspect for broken rings or piston. Measure ring gap and cylinder diameter, taper and out-of-round. Replace defective part as necessary

ENGINE OIL LEAK INSPECTION

Begin with a thorough visual inspection of the engine, particularly at the area of the suspected leak. If an oil leak source is not readily identifiable, the following steps should be followed:

(1) Do not clean or degrease the engine at this time because some solvents may cause rubber to swell, temporarily stopping the leak.

(2) Add an oil soluble dye (use as recommended by manufacturer). Start the engine and let idle for approximately 15 minutes. Check the oil dipstick to make sure the dye is thoroughly mixed as indicated with a bright yellow color under a black light.

(3) Using a black light, inspect the entire engine for fluorescent dye, particularly at the suspected area of oil leak. If the oil leak is found and identified, repair per service manual instructions.

(4) If dye is not observed, drive the vehicle at various speeds for approximately 24km (15 miles), and repeat inspection.

(4) **If the oil leak source is not positively identified at this time**, proceed with the air leak detection test method.

Air Leak Detection Test Method

(1) Disconnect the breather cap to air cleaner hose at the breather cap end. Cap or plug breather cap nipple.

(2) Remove the PCV valve from the cylinder head cover. Cap or plug the PCV valve grommet.

(3) Attach an air hose with pressure gauge and regulator to the dipstick tube.

CAUTION: Do not subject the engine assembly to more than 20.6 kpa (3 PSI) of test pressure.

(4) Gradually apply air pressure from 1 psi to 2.5 psi maximum while applying soapy water at the suspected source. Adjust the regulator to the suitable test pressure that provide the best bubbles which will pinpoint the leak source. If the oil leak is detected and identified, repair per service manual procedures.

(5) If the leakage occurs at the rear oil seal area, refer to the section, Inspection for Rear Seal Area Leak.

(6) If no leaks are detected, turn off the air supply and remove the air hose and all plugs and caps. Install the PCV valve and breather cap hose.

(7) Clean the oil off the suspect oil leak area using a suitable solvent. Drive the vehicle at various speeds approximately 24 km (15 miles). Inspect the engine for signs of an oil leak by using a black light.

INSPECTION FOR REAR SEAL AREA LEAKS

Since it is sometimes difficult to determine the source of an oil leak in the rear seal area of the engine, a more involved inspection is necessary. The following steps should be followed to help pinpoint the source of the leak.

If the leakage occurs at the crankshaft rear oil seal area:

(1) Disconnect the battery.

(2) Raise the vehicle.

(3) Remove torque converter or clutch housing cover and inspect rear of block for evidence of oil.

Use a black light to check for the oil leak:

(a) Circular spray pattern generally indicates seal leakage or crankshaft damage.

(b) Where leakage tends to run straight down, possible causes are a porous block, distributor seal, camshaft bore cup plugs oil galley pipe plugs, oil

DIAGNOSIS AND TESTING (Continued)

filter runoff, and main bearing cap to cylinder block mating surfaces.

(4) If no leaks are detected, pressurize the crankcase as outlined in the, Inspection (Engine oil Leaks in general)

CAUTION: Do not exceed 20.6 kPa (3 psi).

(5) If the leak is not detected, very slowly turn the crankshaft and watch for leakage. If a leak is detected between the crankshaft and seal while slowly turning the crankshaft, it is possible the crankshaft seal surface is damaged. The seal area on the crankshaft could have minor nicks or scratches that can be polished out with emery cloth.

CAUTION: Use extreme caution when crankshaft polishing is necessary to remove minor nicks and scratches. The crankshaft seal flange is especially machined to complement the function of the rear oil seal.

(6) For bubbles that remain steady with shaft rotation, no further inspection can be done until disassembled.

ENGINE OIL PRESSURE

(1) Disconnect connector and remove oil pressure sending unit.

(2) Install Oil Pressure Line and Gauge Tool C-3292 or equivalent. Start engine and record pressure. Refer to Oil Pressure in Engine Specifications for the correct pressures.

SERVICE PROCEDURES

VALVE TIMING

- Disconnect the spark plug wires and remove the spark plugs.
- Remove the engine cylinder head cover.
- Remove the capscrews, bridge and pivot assembly, and rocker arms from above the No.1 cylinder.
- Alternately loosen each capscrew, one turn at a time, to avoid damaging the bridge.
- Rotate the crankshaft until the No.4 piston is at top dead center (TDC) on the compression stroke.
- Rotate the crankshaft counterclockwise (viewed from the front of the engine) 90°.
- Install a dial indicator on the end of the No.1 cylinder intake valve push rod. Use rubber tubing to secure the indicator stem on the push rod.
- Set the dial indicator pointer at zero.
- Set the dial indicator pointer at zero.
- Rotate the crankshaft clockwise (viewed from the front of the engine) until the dial indicator

pointer indicates 0.305 mm (0.012 inch) travel distance (lift).

- The timing notch index on the vibration damper should be aligned with the TDC mark on the timing degree scale.

- If the timing notch is more than 13 mm (1/2 inch) away from the TDC mark in either direction, the valve timing is incorrect.

- If the valve timing is incorrect, the cause may be a broken camshaft pin. It is not necessary to replace the camshaft because of pin failure. A spring pin is available for service replacement.

VALVE, GUIDE AND SEAL

Clean all carbon deposits from the combustion chambers, valve ports, valve stems, valve stem guides and head.

Clean all grime and gasket material from the engine cylinder head machined gasket surface.

Inspect for cracks in the combustion chambers and valve ports.

Inspect for cracks on the exhaust seat.

Inspect for cracks in the gasket surface at each coolant passage.

Inspect valves for burned, cracked or warped heads.

Inspect for scuffed or bent valve stems.

Replace valves displaying any damage.

VALVE REFACING

(1) Use a valve refacing machine to reface the intake and exhaust valves to the specified angle.

(2) After refacing, a margin of at least 0.787 mm (0.031 inch) must remain (Fig. 13). If the margin is less than 0.787 mm (0.031 inch), the valve must be replaced.

VALVE SEAT REFACING

(1) Install a pilot of the correct size in the valve guide bore. Reface the valve seat to the specified angle with a good dressing stone. Remove only enough metal to provide a smooth finish.

(2) Use tapered stones to obtain the specified seat width when required.

(3) Control valve seat runout to a maximum of 0.0635 mm (0.0025 in.)— (Fig. 14).

VALVE STEM OIL SEAL REPLACEMENT

Valve stem oil seals are installed on each valve stem to prevent rocker arm lubricating oil from entering the combustion chamber through the valve guide bores. One seal is marked INT (intake valve) and the other is marked EXH (exhaust valve).

Replace the oil seals whenever valve service is performed or if the seals have deteriorated.

SERVICE PROCEDURES (Continued)

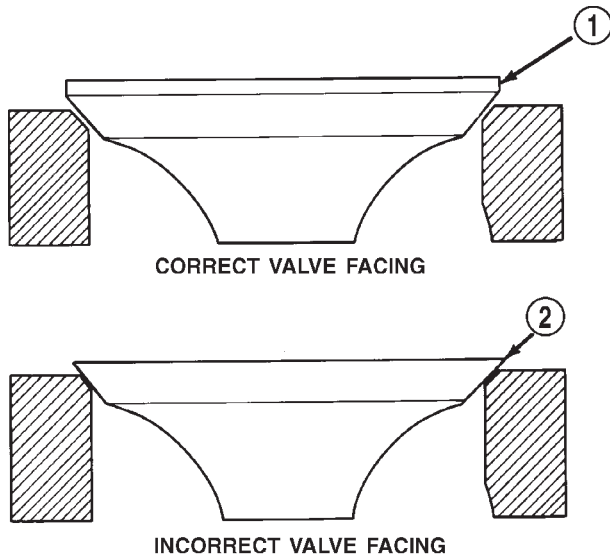

J8909-89

Fig. 13 Valve Facing Margin

- 1 - 0.787 MM (1/32 INCH) VALVE MARGIN
- 2 - NO MARGIN

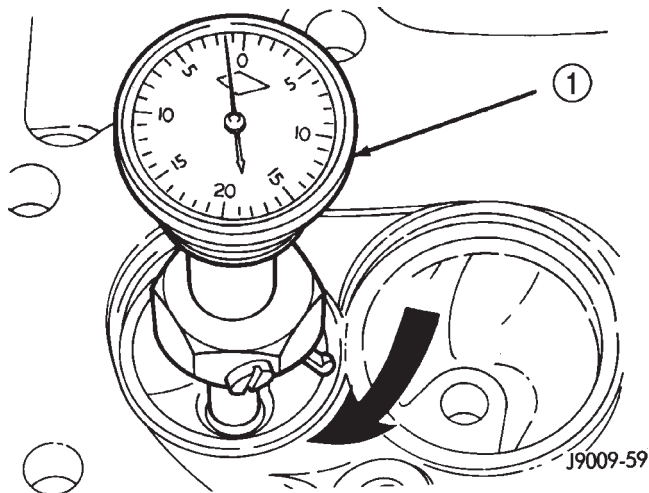

J9009-59

Fig. 14 Measurement of Valve Seat Runout

- 1 - DIAL INDICATOR

VALVE GUIDES

The valve guides are an integral part of the engine cylinder head and are not replaceable.

When the valve stem guide clearance is excessive, the valve guide bores must be reamed oversize. Service valves with oversize stems are available in 0.076 mm (0.003 inch) and 0.381 mm (0.015 inch) increments.

Corresponding oversize valve stem seals are also available and must be used with valves having 0.381 mm (0.015 inch) oversize stems, 0.076mm (.003in.) oversize stems do not require oversize seals.

NOTE: If the valve guides are reamed oversize, the valve seats must be ground to ensure that the valve seat is concentric to the valve guide.

VALVE STEM-TO-GUIDE CLEARANCE MEASUREMENT

Valve stem-to-guide clearance may be measured by either of the following two methods.

PREFERRED METHOD:

- (1) Remove the valve from the head.
- (2) Clean the valve stem guide bore with solvent and a bristle brush.
- (3) Insert a telescoping gauge into the valve stem guide bore approximately 9.525 mm (.375 inch) from the valve spring side of the head (Fig. 15).

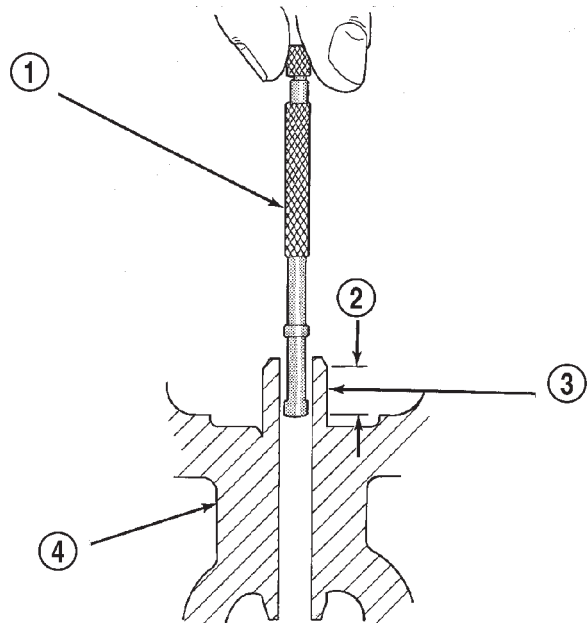

J9509-87

Fig. 15 Measurement of Valve Guide Bore Diameter

- 1 - GAUGE
- 2 - 9.525 MM (3/8 INCH)
- 3 - VALVE STEM GUIDE
- 4 - CYLINDER HEAD

(4) Remove and measure telescoping gauge with a micrometer.

(5) Repeat the measurement with contacts lengthwise to engine cylinder head.

(6) Compare the crosswise to lengthwise measurements to determine out-of-roundness. If the measurements differ by more than 0.0635 mm (0.0025 in.), ream the guide bore to accommodate an oversize valve stem.

(7) Compare the measured valve guide bore diameter with specifications (7.95-7.97 mm or 0.313-0.314

SERVICE PROCEDURES (Continued)

inch). If the measurement differs from specification by more than 0.076 mm (0.003 inch), ream the guide bore to accommodate an oversize valve stem.

ALTERNATIVE METHOD:

(1) Use a dial indicator to measure the lateral movement of the valve stem (stem-to-guide clearance). This must be done with the valve installed in its guide and just off the valve seat (Fig. 16).

(2) Correct clearance is 0.025-0.0762 mm (0.001-0.003 inch). If indicated movement exceeds the specification ream the valve guide to accommodate an oversize valve stem.

NOTE: Valve seats must be ground after reaming the valve guides to ensure that the valve seat is concentric to the valve guide.

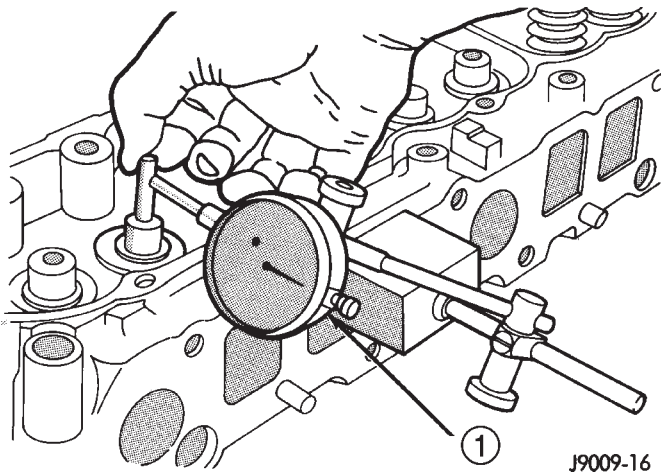

Fig. 16 Measurement of Lateral Movement Of Valve Stem

1 - DIAL INDICATOR

VALVE SPRING TENSION TEST

Use a Universal Valve Spring Tester and a torque wrench to test each valve spring for the specified tension value (Fig. 17).

Replace valve springs that are not within specifications.

PISTON—FITTING

BORE GAUGE METHOD

(1) To correctly select the proper size piston, a cylinder bore gauge, capable of reading in 0.003 mm (.0001 in.) INCREMENTS is required. If a bore gauge is not available, do not use an inside micrometer.

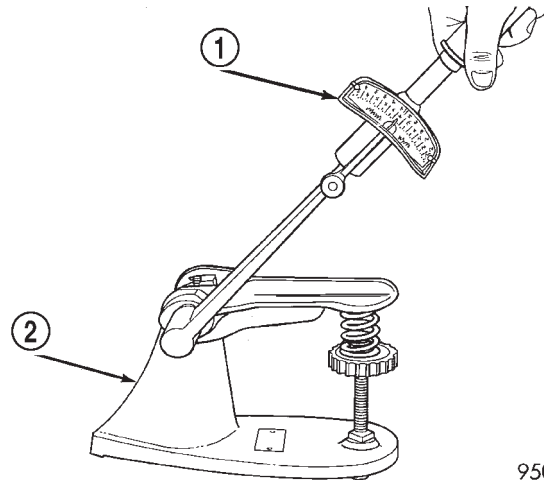

9509-79

Fig. 17 Valve Spring Tester

1 - TORQUE WRENCH
2 - VALVE SPRING TESTER

(2) Measure the inside diameter of the cylinder bore at a point 49.5 mm (1-15/16 inches) below top of bore. Start perpendicular (across or at 90 degrees) to the axis of the crankshaft at point A and then take an additional bore reading 90 degrees to that at point B (Fig. 19).

(3) The coated pistons will be serviced with the piston pin and connecting rod pre-assembled. **The coated piston connecting rod assembly can be used to service previous built engines and MUST be replaced as complete sets.** Tin coated pistons should not be used as replacements for coated pistons.

(4) The coating material is applied to the piston after the final piston machining process. Measuring the outside diameter of a coated piston will not provide accurate results (Fig. 18). Therefore measuring the inside diameter of the cylinder bore with a dial Bore Gauge is **MANDATORY**. To correctly select the proper size piston, a cylinder bore gauge capable of reading in 0.003 mm (.0001 in.) increments is required.

(5) Piston installation into the cylinder bore requires slightly more pressure than that required for non-coated pistons. The bonded coating on the piston will give the appearance of a line-to-line fit with the cylinder bore.

SERVICE PROCEDURES (Continued)

DO NOT MEASURE MOLY COATED PISTON

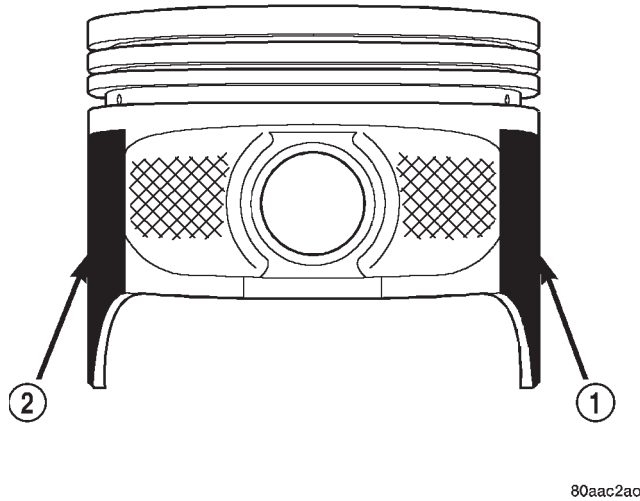

Fig. 18 Moly Coated Piston

- 1 - MOLY COATED
- 2 - MOLY COATED

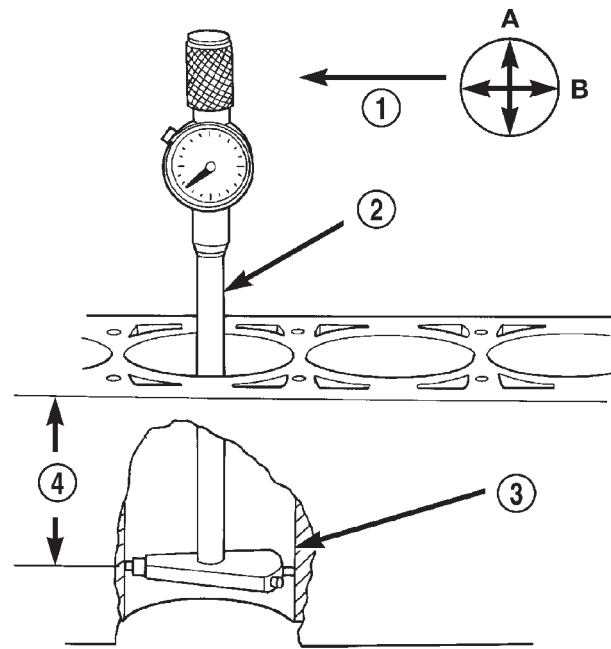

Fig. 19 Bore Gauge

- 1 - FRONT
- 2 - BORE GAUGE
- 3 - CYLINDER BORE
- 4 - 49.5 MM (1-15/16 in)

PISTON SIZE CHART

CYLINDER BORE SIZE	PISTON LETTER SIZE
98.438 - 98.448 mm (3.8755 - 3.8759 in.)	A
98.448 - 98.458 mm (3.8759 - 3.8763 in.)	B
98.458 - 98.468 mm (3.8763 - 3.8767 in.)	C
98.468 - 98.478 mm (3.8767 - 3.8771 in.)	D
98.478 - 98.488 mm (3.8771 - 3.8775 in.)	E
98.488 - 98.498 mm (3.8775 - 3.8779 in.)	F

PISTON RING—FITTING

(1) Carefully clean the carbon from all ring grooves. Oil drain openings in the oil ring groove and pin boss must be clear. DO NOT remove metal from the grooves or lands. This will change ring-to-groove clearances and will damage the ring-to-land seating.

(2) Be sure the piston ring grooves are free of nicks and burrs.

(3) Measure the ring side clearance with a feeler gauge fitted snugly between the ring land and ring (Fig. 20) (Fig. 21). Rotate the ring in the groove. It must move freely around circumference of the groove.

GROOVE HEIGHT

- A 1.530-1.555 mm (0.0602-0.0612 in)
- B 4.035-4.060 mm (0.1589-0.1598 in)

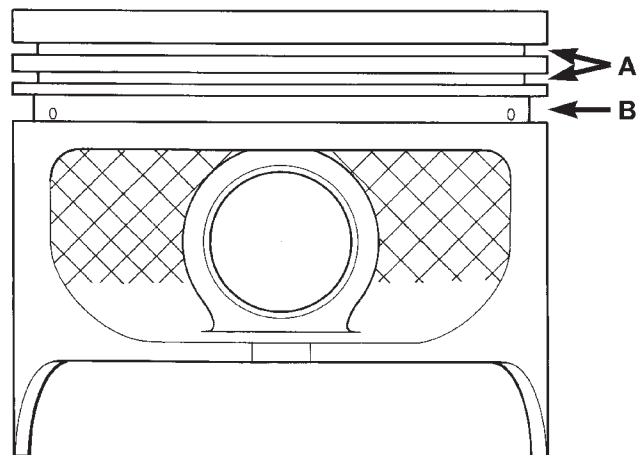
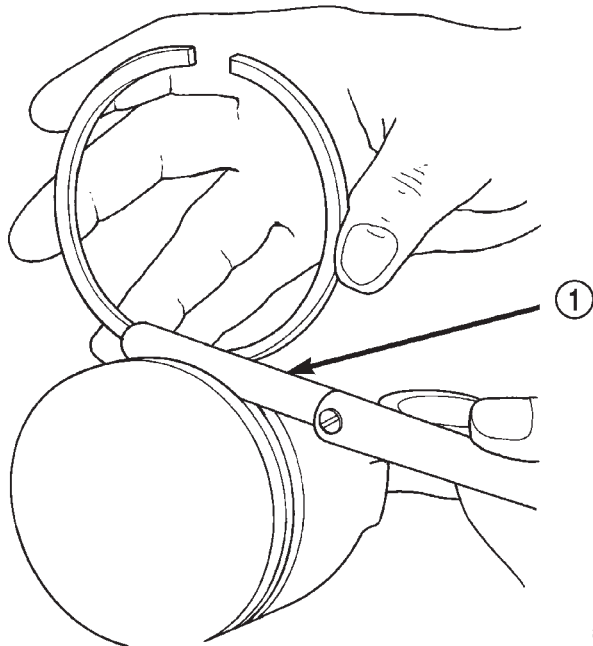

Fig. 20 Piston Dimensions

SERVICE PROCEDURES (Continued)



805dd887

Fig. 21 Ring Side Clearance Measurement

1 - FEELER GAUGE

RING SIDE CLEARANCE CHART

ITEM	SPECIFICATION
Top Compression Ring	0.042 - 0.084 mm (0.0017 - 0.0033 in.)
Second Compression Ring	0.042 - 0.084 mm (0.0017 - 0.0033 in.)
Oil Control Ring	0.06 - 0.21 mm (0.0024 - 0.0083 in.)

(4) Place ring in the cylinder bore and push down with inverted piston to position near lower end of the ring travel. Measure ring gap with a feeler gauge fitting snugly between ring ends (Fig. 22).

(5) The oil control rings are symmetrical, and can be installed with either side up. It is not necessary to use a tool to install the upper and lower rails. Insert oil rail spacer first, then side rails.

(6) The two compression rings are different and cannot be interchanged. The top compression ring can be identified by the shiny coating on the outer sealing surface and can be installed with either side up. (Fig. 23).

(7) The second compression ring has a slight chamfer on the bottom of the inside edge and a dot on the top for correct installation (Fig. 24).

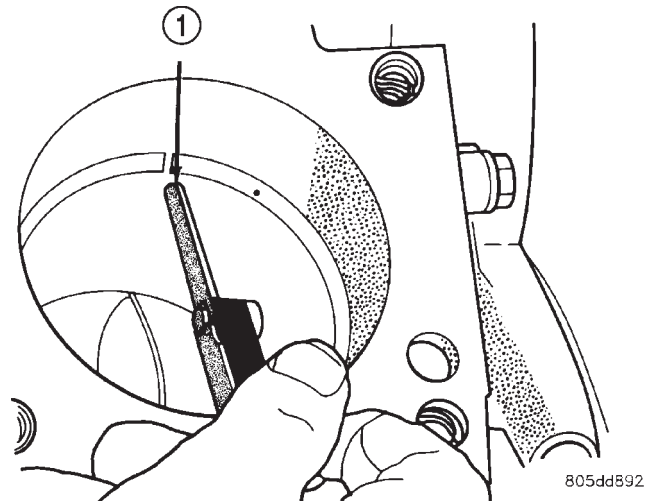

805dd892

Fig. 22 Gap Measurement

1 - FEELER GAUGE

RING GAP MEASUREMENT CHART

ITEM	SPECIFICATION
Top Compression Ring	0.229 - 0.610 mm (0.0090 - 0.0240 in.)
Second Compression Ring	0.483 - 0.965 mm (0.0190 - 0.080 in.)
Oil Control Ring	0.254 - 1.500 mm (0.010 - 0.060 in.)

(8) Using a ring installer, install the second compression ring with the dot facing up (Fig. 24) (Fig. 26).

(9) Using a ring installer, install the top compression ring (either side up).

Ring Gap Orientation

- Position the gaps on the piston as shown (Fig. 27).
- Oil spacer - Gap on center line of piston skirt.
- Oil rails - gap 180° apart on centerline of piston pin bore.
- No. 2 Compression ring - Gap 180° from top oil rail gap.
- No. 1 Compression ring - Gap 180° from No. 2 compression ring gap.

SERVICE PROCEDURES (Continued)

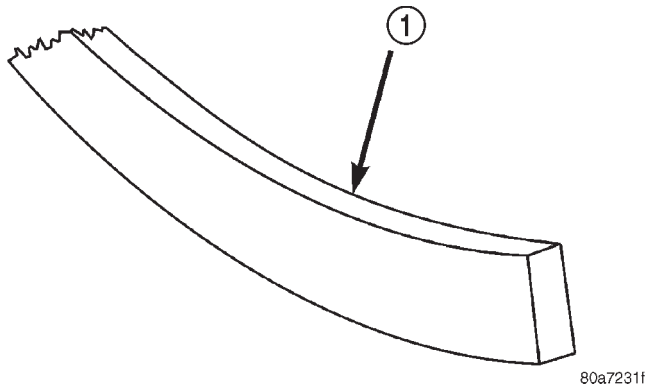

Fig. 23 Top Compression ring identification

- 1 - TOP COMPRESSION RING

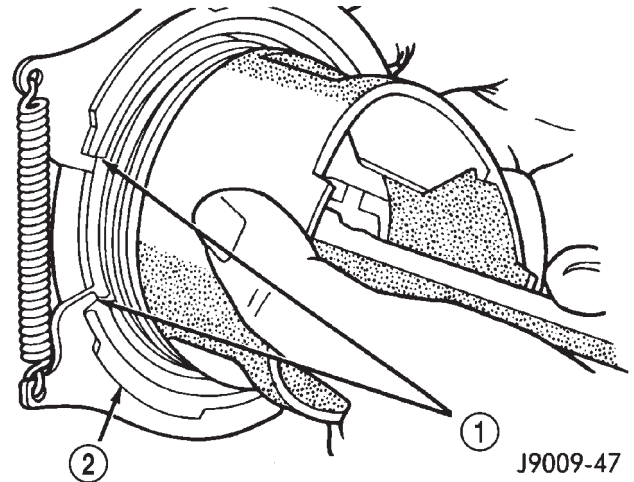

Fig. 26 Compression Ring Installation

- 1 - COMPRESSION RING
2 - RING EXPANDER RECOMMENDED

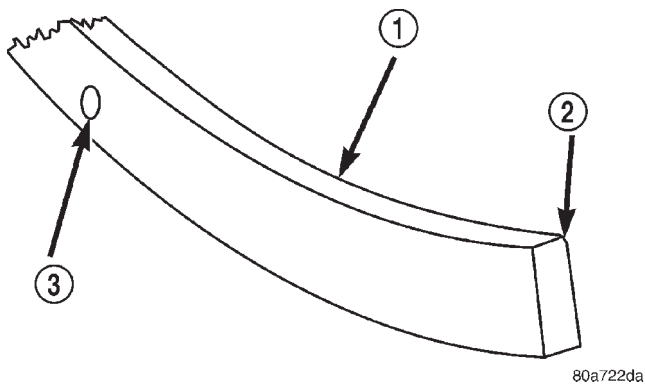

Fig. 24 Second Compression Ring Identification

- 1 - SECOND COMPRESSION RING
2 - CHAMFER
3 - ONE DOT

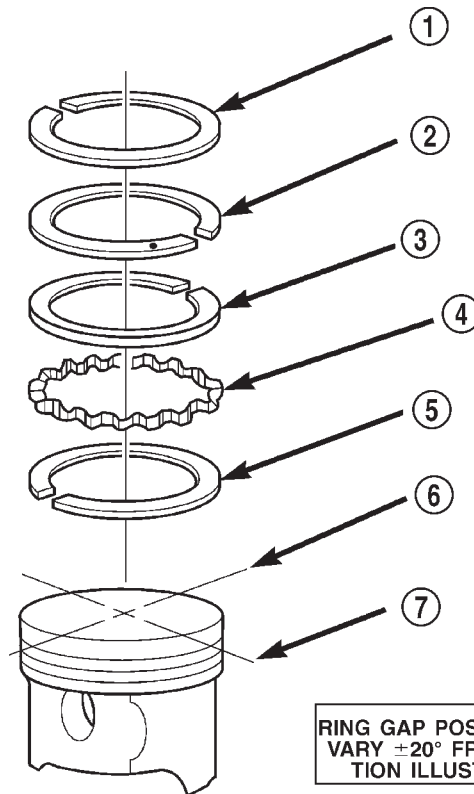

Fig. 27 Ring Gap Orientation

- 1 - TOP COMPRESSION RING
2 - BOTTOM COMPRESSION RING
3 - TOP OIL CONTROL RAIL
4 - OIL RAIL SPACER
5 - BOTTOM OIL CONTROL RAIL
6 - IMAGINARY LINE PARALLEL TO PISTON PIN
7 - IMAGINARY LINE THROUGH CENTER OF PISTON SKIRT

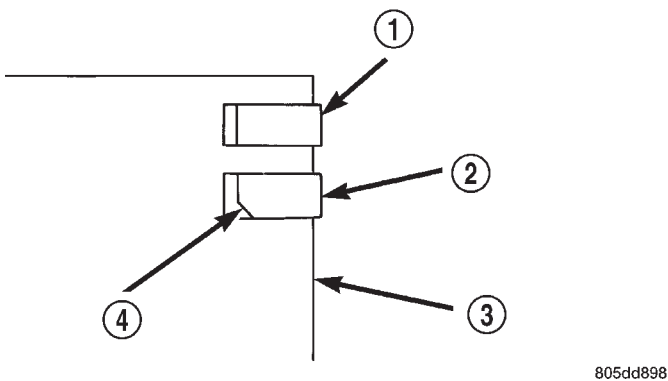

Fig. 25 Compression Ring Chamfer Location

- 1 - TOP COMPRESSION RING
2 - SECOND COMPRESSION RING
3 - PISTON
4 - CHAMFER

80a7233c

SERVICE PROCEDURES (Continued)

CONNECTING ROD BEARINGS—FITTING

Inspect the connecting rod bearings for scoring and bent alignment tabs (Fig. 28) (Fig. 29). Check the bearings for normal wear patterns, scoring, grooving, fatigue and pitting (Fig. 30). Replace any bearing that shows abnormal wear.

Inspect the connecting rod journals for signs of scoring, nicks and burrs.

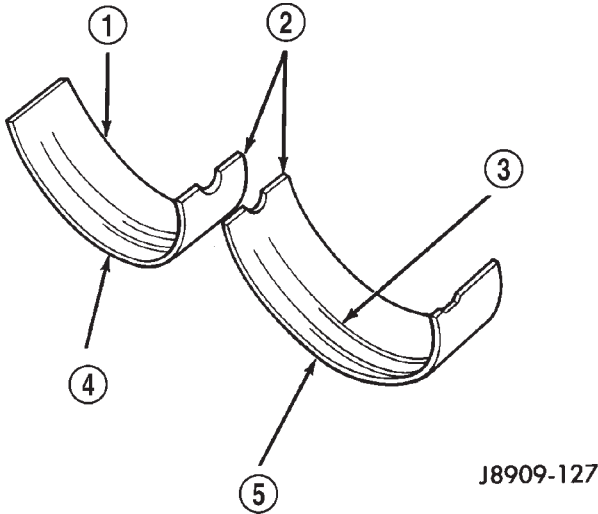

Fig. 28 Connecting Rod Bearing Inspection

- 1 - UPPER BEARING HALF
- 2 - MATING EDGES
- 3 - GROOVES CAUSED BY ROD BOLTS SCRATCHING JOURNAL DURING INSTALLATION
- 4 - WEAR PATTERN — ALWAYS GREATER ON UPPER BEARING
- 5 - LOWER BEARING HALF

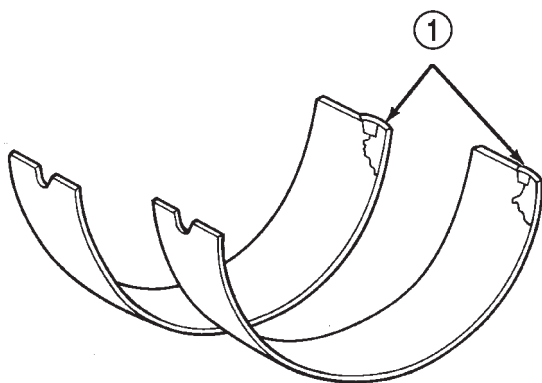

Fig. 29 Locking Tab Inspection

- 1 - ABNORMAL CONTACT AREA CAUSED BY LOCKING TABS NOT FULLY SEATED OR BEING BENT

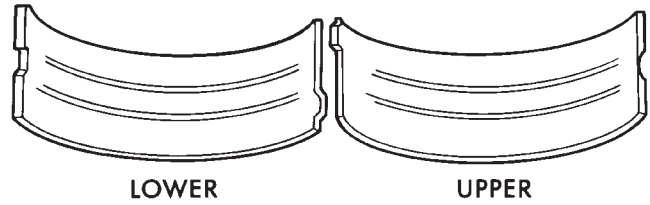

Fig. 30 Scoring Caused by Insufficient Lubrication or by Damaged Crankshaft Pin Journal

necting rod journals. If wear patterns or damage to any of these components indicate the probability of a misaligned connecting rod, inspect it for correct rod alignment. Replace misaligned, bent or twisted connecting rods.

- (1) Wipe the oil from the connecting rod journal.
- (2) Use short rubber hose sections over rod bolts during installation.
- (3) Lubricate the upper bearing insert and install in connecting rod.
- (4) Use piston ring compressor to install the rod and piston assemblies. The oil squirt holes in the rods must face the camshaft. The arrow on the piston crown should point to the front of the engine (Fig. 31). Verify that the oil squirt holes in the rods face the camshaft and that the arrows on the pistons face the front of the engine.

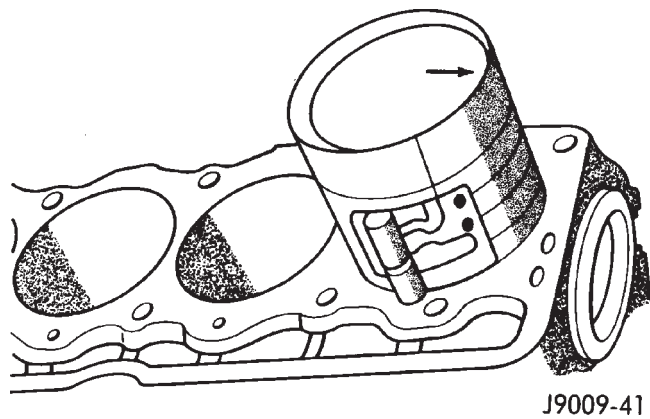

Fig. 31 Rod and Piston Assembly Installation

(5) Install the lower bearing insert in the bearing cap. The lower insert must be dry. Place strip of Plastigage across full width of the lower insert at the center of bearing cap. Plastigage must not crumble in use. If brittle, obtain fresh stock.

(6) Install bearing cap and connecting rod on the journal and tighten nuts to 45 N-m (33 ft. lbs.) torque. DO NOT rotate crankshaft. Plastigage will smear, resulting in inaccurate indication.

(7) Remove the bearing cap and determine amount of bearing-to-journal clearance by measuring the width of compressed Plastigage (Fig. 32). Refer to

Misaligned or bent connecting rods can cause abnormal wear on pistons, piston rings, cylinder walls, connecting rod bearings and crankshaft con-

SERVICE PROCEDURES (Continued)

Engine Specifications for the proper clearance. **Plastigage should indicate the same clearance across the entire width of the insert. If the clearance varies, it may be caused by either a tapered journal, bent connecting rod or foreign material trapped between the insert and cap or rod.**

(8) If the correct clearance is indicated, replacement of the bearing inserts is not necessary. Remove the Plastigage from crankshaft journal and bearing insert. Proceed with installation.

(9) If bearing-to-journal clearance exceeds the specification, install a pair of 0.0254 mm (0.001 inch) undersize bearing inserts. All the odd size inserts must be on the bottom. The sizes of the service replacement bearing inserts are stamped on the backs of the inserts. Measure the clearance as described in the previous steps.

(10) The clearance is measured with a pair of 0.0254 mm (0.001 inch) undersize bearing inserts installed. This will determine if two 0.0254 mm (0.001 inch) undersize inserts or another combination is needed to provide the correct clearance (refer to Connecting Rod Bearing Fitting Chart).

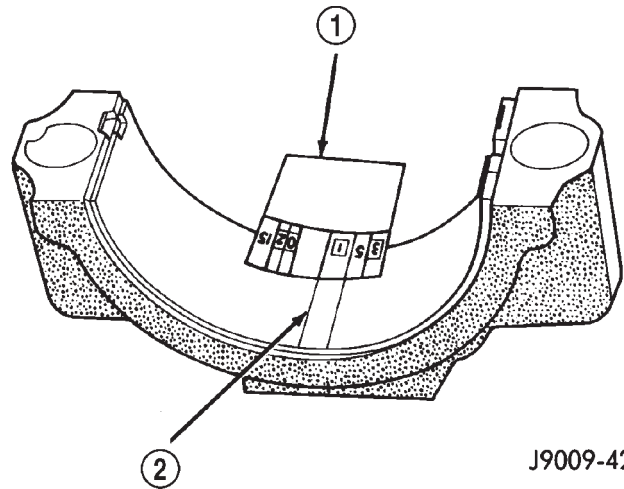

J9009-42

Fig. 32 Measuring Bearing Clearance with Plastigage

- 1 - PLASTIGAGE SCALE
- 2 - COMPRESSED PLASTIGAGE

CONNECTING ROD BEARING FITTING CHART

CRANKSHAFT JOURNAL		CORRESPONDING CONNECTING ROD BEARING INSERT	
Color Code	Diameter	Upper Insert Size	Lower Insert Size
Yellow	53.2257-53.2079 mm (2.0955-2.0948 in.)	Yellow - Standard	Yellow - Standard
Orange	53.2079 - 53.1901 mm (2.0948 - 2.0941 in.) 0.0178 mm (0.0007 in.) Undersize	Yellow - Standard	Blue - Undersize 0.025 mm (0.001 in.)
Blue	53.1901 - 53.1724 mm (2.0941 - 2.0934 in.) 0.0356 mm (0.0014 in.) Undersize	Blue - Undersize 0.025 mm (0.001 in.)	Blue - Undersize 0.025 mm (0.001 in.)
Red	52.9717 - 52.9539 mm (2.0855 - 2.0848 in.) 0.254 mm (0.010 in.) Undersize	Red - Undersize 0.254 mm (0.010 in.)	Red - Undersize 0.254 mm (0.010 in.)

SERVICE PROCEDURES (Continued)

(11) **FOR EXAMPLE:** If the initial clearance was 0.0762 mm (0.003 inch), 0.025 mm (0.001 inch) undersize inserts would reduce the clearance by 0.025 mm (0.001 inch). The clearance would be 0.002 inch and within specification. A 0.051 mm (0.002 inch) undersize insert would reduce the initial clearance an additional 0.013 mm (0.0005 inch). The clearance would then be 0.038 mm (0.0015 inch).

(12) Repeat the Plastigage measurement to verify your bearing selection prior to final assembly.

(13) Once you have selected the proper insert, install the insert and cap. Tighten the connecting rod bolts to 45 N·m (33 ft. lbs.) torque.

Slide snug-fitting feeler gauge between the connecting rod and crankshaft journal flange (Fig. 33). Refer to Engine Specifications for the proper clearance. Replace the connecting rod if the side clearance is not within specification.

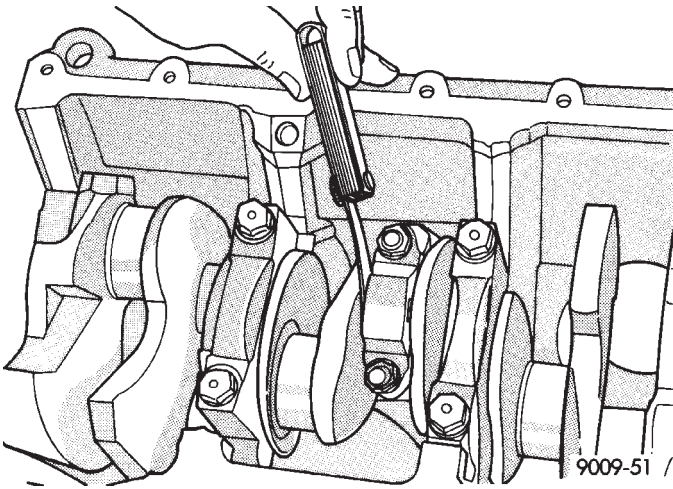

Fig. 33 Checking Connecting Rod Side Clearance—Typical

FITTING CRANKSHAFT MAIN BEARINGS

INSPECTION

Wipe the inserts clean and inspect for abnormal wear patterns and for metal or other foreign material imbedded in the lining. Normal main bearing insert wear patterns are illustrated (Fig. 34). In general the lower bearing half will have a heavier wear pattern.

NOTE: If any of the crankshaft journals are scored, remove the engine for crankshaft repair.

Inspect the back of the inserts for fractures, scrapings or irregular wear patterns.

Inspect the upper insert locking tabs for damage. Replace all damaged or worn bearing inserts.

FITTING BEARINGS (CRANKSHAFT INSTALLED)

The main bearing caps, numbered (front to rear) from 1 through 5 have an arrow to indicate the for-

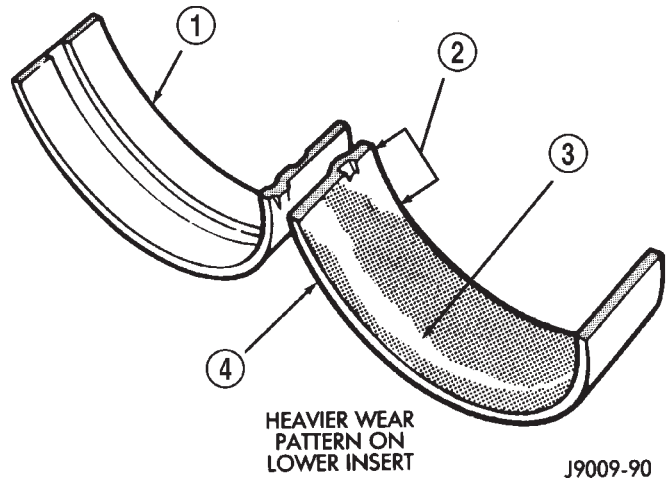

Fig. 34 Main Bearing Wear Patterns

- 1 - UPPER INSERT
- 2 - NO WEAR IN THIS AREA
- 3 - LOW AREA IN BEARING LINING
- 4 - LOWER INSERT

ward position. The upper main bearing inserts are grooved to provide oil channels while the lower inserts are smooth.

Each bearing insert pair is selectively fitted to its respective journal to obtain the specified operating clearance. In production, the select fit is obtained by using various-sized color-coded bearing insert pairs as listed in the Main Bearing Fitting Chart. The bearing color code appears on the edge of the insert. **The size is not stamped on bearing inserts used for engine production.**

The main bearing journal size (diameter) is identified by a color-coded paint mark on the adjacent cheek. The rear main journal, is identified by a color-coded paint mark on the crankshaft rear flange.

When required, upper and lower bearing inserts of different sizes may be used as a pair. A standard size insert is sometimes used in combination with a 0.025 mm (0.001 inch) undersize insert to reduce the clearance by 0.013 mm (0.0005 inch). **Never use a pair of bearing inserts with greater than a 0.025 mm (0.001 inch) difference in size. Refer to the Bearing Insert Pair Chart.**

BEARING INSERT PAIR CHART

INSERT	CORRECT	INCORRECT
UPPER	STANDARD	STANDARD
LOWER	0.025 mm (0.001 in.) UNDERSIZE	0.051 mm (0.002 in.) UNDERSIZE

SERVICE PROCEDURES (Continued)

NOTE: When replacing inserts, the odd size inserts must be either all on the top (in cylinder block) or all on the bottom (in main bearing cap).

Once the bearings have been properly fitted, proceed to Crankshaft Main Bearing—Installation.

BEARING-TO-JOURNAL CLEARANCE (CRANKSHAFT INSTALLED)

When using Plastigage, check only one bearing clearance at a time.

Install the grooved main bearings into the cylinder block and the non-grooved bearings into the bearing caps.

Install the crankshaft into the upper bearings dry.

Place a strip of Plastigage across full width of the crankshaft journal to be checked.

Install the bearing cap and tighten the bolts to 108 N·m (80 ft. lbs.) torque.

NOTE: DO NOT rotate the crankshaft. This will cause the Plastigage to shift, resulting in an inaccurate reading. Plastigage must not be permitted to crumble. If brittle, obtain fresh stock.

Remove the bearing cap. Determine the amount of clearance by measuring the width of the compressed Plastigage with the scale on the Plastigage envelope (Fig. 35). Refer to Engine Specifications for the proper clearance.

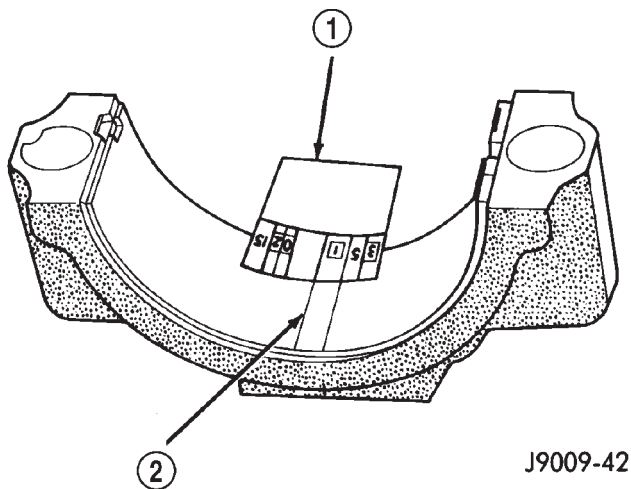

J9009-42

Fig. 35 Measuring Bearing Clearance with Plastigage

- 1 - PLASTIGAGE SCALE
2 - COMPRESSED PLASTIGAGE

Plastigage should indicate the same clearance across the entire width of the insert. If clearance varies, it may indicate a tapered journal or foreign material trapped behind the insert.

If the specified clearance is indicated and there are no abnormal wear patterns, replacement of the bear-

ing inserts is not necessary. Remove the Plastigage from the crankshaft journal and bearing insert. Proceed to Crankshaft Main Bearing—Installation.

If the clearance exceeds specification, install a pair of 0.025 mm (0.001 inch) undersize bearing inserts and measure the clearance as described in the previous steps.

The clearance indicated with the 0.025 mm (0.001 inch) undersize insert pair installed will determine if this insert size or some other combination will provide the specified clearance. **FOR EXAMPLE:** If the clearance was 0.0762 mm (0.003 inch) originally, a pair of 0.0254 mm (0.001 inch) undersize inserts would reduce the clearance by 0.0254 mm (0.001 inch). The clearance would then be 0.0508 mm (0.002 inch) and within the specification. A 0.051 mm (0.002 inch) undersize bearing insert and a 0.0254 mm (0.001 inch) undersize insert would reduce the original clearance an additional 0.0127 mm (0.0005 inch). The clearance would then be 0.0381 mm (0.0015 inch).

CAUTION: Never use a pair of inserts that differ more than one bearing size as a pair.

FOR EXAMPLE: DO NOT use a standard size upper insert and a 0.051 mm (0.002 inch) undersize lower insert.

If the clearance exceeds specification using a pair of 0.051 mm (0.002 inch) undersize bearing inserts, measure crankshaft journal diameter with a micrometer. If the journal diameter is correct, the crankshaft bore in the cylinder block may be misaligned, which requires cylinder block replacement or machining to true bore.

If journals 1 through 5 diameters are less than 63.4517 mm (2.4981 inches), replace crankshaft or grind crankshaft down to accept the appropriate undersize bearing inserts.

Once the proper clearances have been obtained, proceed to Crankshaft Main Bearing—Installation.

MAIN BEARING JOURNAL DIAMETER (CRANKSHAFT REMOVED)

Remove the crankshaft from the cylinder block (refer to Cylinder Block - Disassemble).

Clean the oil off the main bearing journal.

Determine the maximum diameter of the journal with a micrometer. Measure at two locations 90° apart at each end of the journal.

The maximum allowable taper and out of round is 0.013 mm (0.0005 inch). Compare the measured diameter with the journal diameter specification (Main Bearing Fitting Chart). Select inserts required to obtain the specified bearing-to-journal clearance.

Once the proper clearances have been obtained, proceed to Crankshaft Main Bearing—Installation.

SERVICE PROCEDURES (Continued)

MAIN BEARING FITTING CHART

CRANKSHAFT JOURNALS		CORRESPONDING CRANKSHAFT BEARING INSERT	
Color Code	Diameter	Upper Insert Size	Lower Insert Size
Yellow	63.5025 - 63.4898 mm (2.5001 - 2.4996 in.)	Yellow - Standard	Yellow - Standard
Orange	63.4898 - 63.4771mm (2.4996 - 2.4991 in.) 0.0127 mm (0.0005 in.) Undersize	Yellow - Standard	Blue- Undersize 0.025 mm (0.001 in.)
Blue	63.4771 - 63.4644 mm (2.4991 - 2.4986 in.) 0.0254 mm (0.001 in.) Undersize	Blue- Undersize 0.025 mm (0.001 in.)	Blue- Undersize 0.025 mm (0.001 in.)
Green	63.4644 - 63.4517 mm (2.4986 - 2.4981 in.) 0.0381 mm (0.0015 in.) Undersize	Blue - Undersize 0.025 mm (0.001 in.)	Green - Undersize 0.051 mm (0.002 in.)
Red	63.2485 - 63.2358 mm (2.4901 - 2.4896 in.) 0.254 mm (0.010 in.) Undersize	Red - Undersize 0.254 mm (0.010 in.)	Red - Undersize 0.254 mm (0.010 in.)

FORM-IN-PLACE GASKETS

There are several places where form-in-place gaskets are used on the engine. **DO NOT use form-in-place gasket material unless specified.** Care must be taken when applying form-in-place gaskets. Bead size, continuity and location are of great importance. Too thin a bead can result in leakage while too much can result in spill-over. A continuous bead of the proper width is essential to obtain a leak-free joint.

Two types of form-in-place gasket materials are used in the engine area (Mopar Silicone Rubber Adhesive Sealant and Mopar Gasket Maker). Each have different properties and cannot be used interchangeably.

MOPAR SILICONE RUBBER ADHESIVE SEALANT

Mopar Silicone Rubber Adhesive Sealant, normally black in color, is available in 3 ounce tubes. Moisture in the air causes the sealant material to cure. This material is normally used on flexible metal flanges. It has a shelf life of a year and will not properly cure if over aged. Always inspect the package for the expiration date before use.

MOPAR GASKET MAKER

Mopar Gasket Maker, normally red in color, is available in 6 cc tubes. This anaerobic type gasket material cures in the absence of air when squeezed between smooth machined metallic surfaces. It will not cure if left in the uncovered tube. DO NOT use on flexible metal flanges.

SURFACE PREPARATION

Parts assembled with form-in-place gaskets may be disassembled without unusual effort. In some instances, it may be necessary to lightly tap the part with a mallet or other suitable tool to break the seal between the mating surfaces. A flat gasket scraper may also be lightly tapped into the joint but care must be taken not to damage the mating surfaces.

Scrape or wire brush all gasket surfaces to remove all loose material. Inspect stamped parts to ensure gasket rails are flat. Flatten rails with a hammer on a flat plate, if required. Gasket surfaces must be free of oil and dirt. Make sure the old gasket material is removed from blind attaching holes.

GASKET APPLICATION

Assembling parts using a form-in-place gasket requires care.

SERVICE PROCEDURES (Continued)

Mopar Silicone Rubber Adhesive Sealant should be applied in a continuous bead approximately 3 mm (0.12 inch) in diameter. All mounting holes must be circled. For corner sealing, a 3 or 6 mm (1/8 or 1/4 inch) drop is placed in the center of the gasket contact area. Uncured sealant may be removed with a shop towel. Components should be torqued in place while the sealant is still wet to the touch (within 10 minutes). The use of a locating dowel is recommended during assembly to prevent smearing the material off location.

Mopar Gasket Maker should be applied sparingly to one gasket surface. The sealant diameter should be 1.00 mm (0.04 inch) or less. Be certain the material surrounds each mounting hole. Excess material can easily be wiped off. Components should be torqued in place within 15 minutes. The use of a locating dowel is recommended during assembly to prevent smearing the material off location.

ENGINE PERFORMANCE

It is important that the vehicle is operating to its optimum performance level to maintain fuel economy and the lowest emission levels. If vehicle is not operating to these standards, refer to Engine Diagnosis outlined in this section. The following procedures can assist in achieving the proper engine diagnosis.

- (1) Test cranking amperage draw. Refer to Electrical Group 8B, Cold Cranking Test.
- (2) Check intake manifold bolt torque; Refer to Group 11, Exhaust System and Intake Manifold.
- (3) Perform cylinder compression test. Refer to Cylinder Compression Pressure Test in the Engine Diagnosis area of this section.
- (4) Clean or replace spark plugs as necessary and adjust gap as specified in Electrical Group 8D. Tighten to specifications.
- (5) Test resistance of spark plug cables. Refer to Electrical Group 8D, Spark Plug Cables.
- (6) Inspect the primary wires. Test coil output voltage and primary resistance. Replace parts as necessary. Refer to Electrical Group 8D, for specifications.
- (7) Test fuel pump for pressure. Refer to Group 14, Fuel System Specifications.
- (8) The air filter elements should be replaced as specified in Lubrication and Maintenance, Group 0.
- (9) Inspect crankcase ventilation system as outlined in Group 0, Lubrication and Maintenance. For emission controls see Group 25, Emission Controls for service procedures.
- (10) Road test vehicle as a final test.

HONING CYLINDER BORES

Before honing, stuff plenty of clean shop towels under the bores and over the crankshaft to keep

abrasive materials from entering the crankshaft area.

(1) Used carefully, the Cylinder Bore Sizing Hone C-823 equipped with 220 grit stones, is the best tool for this job. In addition to deglazing, it will reduce taper and out-of-round as well as removing light scuffing, scoring or scratches. Usually a few strokes will clean up a bore and maintain the required limits.

CAUTION: DO NOT use rigid type hones to remove cylinder wall glaze.

(2) Deglazing of the cylinder walls may be done if the cylinder bore is straight and round. Use a cylinder surfacing hone, Honing Tool C-3501, equipped with 280 grit stones (C-3501-3810). 20-60 strokes, depending on the bore condition, will be sufficient to provide a satisfactory surface. Using honing oil C-3501-3880 or a light honing oil available from major oil distributors.

CAUTION: DO NOT use engine or transmission oil, mineral spirits or kerosene.

(3) Honing should be done by moving the hone up and down fast enough to get a crosshatch pattern. The hone marks should INTERSECT at 50° to 60° for proper seating of rings (Fig. 36).

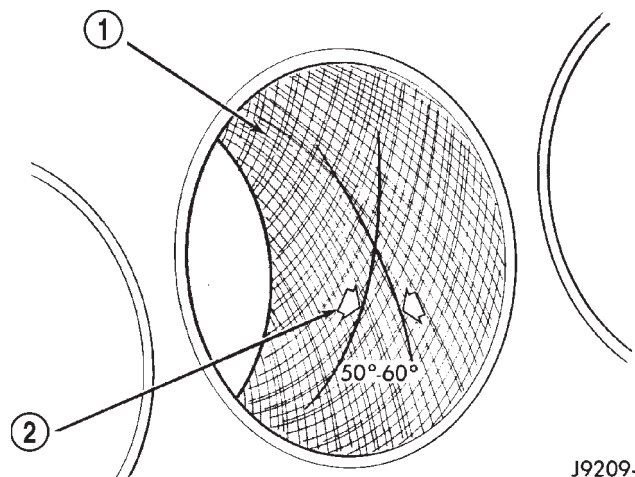

J9209-12

Fig. 36 Cylinder Bore Crosshatch Pattern

- 1 - CROSSHATCH PATTERN
2 - INTERSECT ANGLE

(4) A controlled hone motor speed between 200 and 300 RPM is necessary to obtain the proper crosshatch angle. The number of up and down strokes per minute can be regulated to get the desired 50° to 60° angle. Faster up and down strokes increase the crosshatch angle.

(5) After honing, it is necessary that the block be cleaned to remove all traces of abrasive. Use a brush

SERVICE PROCEDURES (Continued)

to wash parts with a solution of hot water and detergent. Dry parts thoroughly. Use a clean, white, lint-free cloth to check that the bore is clean. Oil the bores after cleaning to prevent rusting.

REPAIR DAMAGED OR WORN THREADS

CAUTION: Be sure that the tapped holes maintain the original center line.

Damaged or worn threads can be repaired. Essentially, this repair consists of:

- Drilling out worn or damaged threads.
- Tapping the hole with a special Heli-Coil Tap, or equivalent.
- Installing an insert into the tapped hole to bring the hole back to its original thread size.

SERVICE ENGINE ASSEMBLY (SHORT BLOCK)

A service replacement engine assembly (short block) may be installed whenever the original cylinder block is defective or damaged beyond repair. It consists of the cylinder block, crankshaft, piston and rod assemblies. If needed, the camshaft must be procured separately and installed before the engine is installed in the vehicle.

A short block is identified with the letter "S" stamped on the same machined surface where the build date code is stamped for complete engine assemblies.

Installation includes the transfer of components from the defective or damaged original engine. Follow the appropriate procedures for cleaning, inspection and torque tightening.

HYDROSTATIC LOCK

When an engine is suspected of hydrostatic lock (regardless of what caused the problem), follow the steps below.

- (1) Perform the Fuel Pressure Release Procedure (refer to Group 14, Fuel System).
- (2) Disconnect the negative cable from the battery.
- (3) Inspect air cleaner, induction system and intake manifold to ensure system is dry and clear of foreign material.
- (4) Place a shop towel around the spark plugs to catch any fluid that may possibly be under pressure in the cylinder head. Remove the plugs from the engine.

CAUTION: DO NOT use the starter motor to rotate the crankshaft. Severe damage could occur.

- (5) With all spark plugs removed, rotate the crankshaft using a breaker bar and socket.
- (6) Identify the fluid in the cylinders (i.e. coolant, fuel, oil, etc.).

(7) Make sure all fluid has been removed from the cylinders.

(8) Repair engine or components as necessary to prevent this problem from occurring again.

(9) Squirt engine oil into the cylinders to lubricate the walls. This will prevent damage on restart.

(10) Install new spark plugs. Tighten the spark plugs to 37 N·m (27 ft. lbs.) torque.

(11) Drain engine oil. Remove and discard the oil filter.

(12) Install the drain plug. Tighten the plug to 34 N·m (25 ft. lbs.) torque.

(13) Install a new oil filter.

(14) Fill engine crankcase with the specified amount and grade of oil (refer to Group 0, Lubrication and Maintenance).

(15) Connect the negative cable to the battery.

(16) Start the engine and check for any leaks.

ENGINE OIL SERVICE

WARNING: NEW OR USED ENGINE OIL CAN BE IRRITATING TO THE SKIN. AVOID PROLONGED OR REPEATED SKIN CONTACT WITH ENGINE OIL. CONTAMINANTS IN USED ENGINE OIL, CAUSED BY INTERNAL COMBUSTION, CAN BE HAZARDOUS TO YOUR HEALTH. THOROUGHLY WASH EXPOSED SKIN WITH SOAP AND WATER. DO NOT WASH SKIN WITH GASOLINE, DIESEL FUEL, THINNER, OR SOLVENTS, HEALTH PROBLEMS CAN RESULT. DO NOT POLLUTE, DISPOSE OF USED ENGINE OIL PROPERLY.

ENGINE OIL SPECIFICATION

CAUTION: Do not use non-detergent or straight mineral oil when adding or changing crankcase lubricant. Engine failure can result.

API SERVICE GRADE CERTIFIED

In gasoline engines, use an engine oil that is API Service Grade Certified (Fig. 37).

Standard engine oil identification notations have been adopted to aid in the proper selection of engine oil. The identifying notations are located on the label of engine oil plastic bottles and the top of engine oil cans (Fig. 37).

SAE VISCOSITY

An SAE viscosity grade is used to specify the viscosity of engine oil. SAE 10W-30 specifies a multiple viscosity engine oil.

When choosing an engine oil, consider the range of temperatures the vehicle will be operated in before the next oil change. Select an engine oil that is best

SERVICE PROCEDURES (Continued)

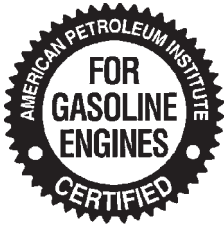

9400-9

Fig. 37 Engine Oil Container Standard Notations

suited to your area's particular ambient temperature range and variation (Fig. 38).

ENGINE OIL VISCOSITY GRADES								
					10W-30 (Preferred)			
		5W-30						
°F	-20°	0°	10°	20°	32°	60°	80°	100°
°C	-29°	-18°	-12°	-7°	0°	16°	27°	38°
Temperature range anticipated before next oil change								

Fig. 38 Temperature/Engine Oil Viscosity**ENERGY CONSERVING OIL**

An Energy Conserving type oil is recommended for gasoline engines. The designation of ENERGY CONSERVING is located on the label of an engine oil container.

CRANKCASE OIL LEVEL INSPECTION

CAUTION: Do not overfill crankcase with engine oil, oil foaming and oil pressure loss can result.

The engine oil level indicator (Dipstick) is located at the right rear of the 2.5L engine. Inspect engine oil level approximately every 800 kilometers (500 miles). Unless the engine has exhibited loss of oil pressure, run the engine for about five minutes before checking oil level. Checking engine oil level on a cold engine is not accurate.

To ensure proper lubrication of an engine, the engine oil must be maintained at an acceptable level. The acceptable levels are indicated between the ADD and SAFE marks on the engine oil dipstick (Fig. 39).

- (1) Position vehicle on level surface.
- (2) With engine OFF, allow approximately ten minutes for oil to settle to bottom of crankcase, remove engine oil dipstick.
- (3) Wipe dipstick clean.
- (4) Install dipstick and verify it is seated in the tube.

(5) Remove dipstick, with handle held above the tip, note oil level reading (Fig. 39).

(6) Add oil only if level is below the ADD mark on dipstick.

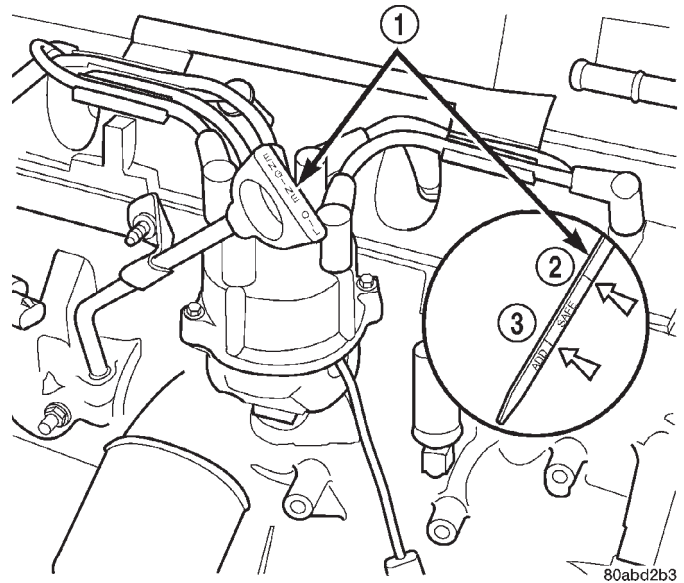
**Fig. 39 Engine Oil Dipstick—2.5L Engine**

- 1 - DIPSTICK
- 2 - SAFE
- 3 - ADD

ENGINE OIL CHANGE

Change engine oil at mileage and time intervals described in Maintenance Schedules.

Run engine until achieving normal operating temperature.

(1) Position the vehicle on a level surface and turn engine off.

(2) Hoist and support vehicle on safety stands.

(3) Remove oil fill cap.

(4) Place a suitable drain pan under crankcase drain.

(5) Remove drain plug from crankcase and allow oil to drain into pan. Inspect drain plug threads for stretching or other damage. Replace drain plug if damaged.

(6) Install drain plug in crankcase.

(7) Lower vehicle and fill crankcase with specified type and amount of engine oil described in this section.

(8) Install oil fill cap.

(9) Start engine and inspect for leaks.

(10) Stop engine and inspect oil level.

SERVICE PROCEDURES (Continued)

ENGINE OIL FILTER CHANGE

FILTER SPECIFICATION

CAUTION: Do not use oil filter with metric threads. The proper oil filter has SAE type 3/4 X 16 threads. An oil filter with metric threads can result in oil leaks and engine failure.

All Jeep engines are equipped with a high quality full-flow, throw-away type oil filter. Chrysler Corporation recommends a Mopar or equivalent oil filter be used.

OIL FILTER REMOVAL

- (1) Position a drain pan under the oil filter.
- (2) Using a suitable oil filter wrench loosen filter.
- (3) Rotate the oil filter counterclockwise to remove it from the cylinder block oil filter boss (Fig. 40).

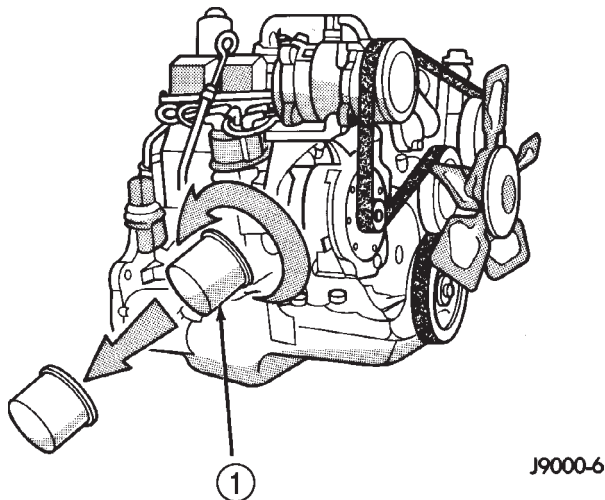

Fig. 40 Oil Filter—2.5L Engine

1 - OIL FILTER

(4) When filter separates from adapter nipple, tip gasket end upward to minimize oil spill. Remove filter from vehicle.

(5) With a wiping cloth, clean the gasket sealing surface (Fig. 41) of oil and grime.

OIL FILTER INSTALLATION

(1) Lightly lubricate oil filter gasket with engine oil or chassis grease.

(2) Thread filter onto adapter nipple. When gasket makes contact with sealing surface, (Fig. 41) hand tighten filter one full turn, do not over tighten.

(3) Add oil, verify crankcase oil level and start engine. Inspect for oil leaks.

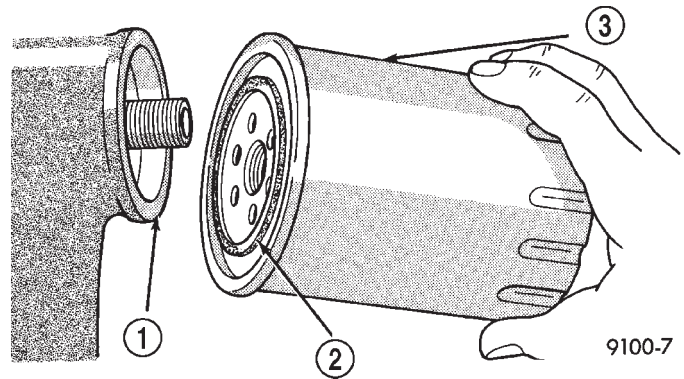

Fig. 41 Oil Filter Sealing Surface—Typical

- 1 - SEALING SURFACE
- 2 - RUBBER GASKET
- 3 - OIL FILTER

USED ENGINE OIL DISPOSAL

Care should be exercised when disposing used engine oil after it has been drained from a vehicle engine. Refer to the WARNING at beginning of this section.

REMOVAL AND INSTALLATION

ENGINE MOUNTS—FRONT

The front mounts support the engine at each side. These supports are made of resilient rubber.

REMOVAL

- (1) Disconnect negative cable from battery.
- (2) Raise the vehicle.
- (3) Support the engine.
- (4) Remove through bolt nut (Fig. 42). DO NOT remove the through bolt.
- (5) Remove the retaining bolts and nuts from the support cushions (Fig. 42).
- (6) Remove the through bolt.
- (7) Remove the support cushions.

INSTALLATION

(1) If the engine support bracket was removed, position the LEFT bracket (Fig. 42) and the RIGHT bracket (Fig. 43) onto the cylinder block. Install the bolts and stud nuts.

(a) RIGHT SIDE (Fig. 43) —Tighten the bolts to 61 N·m (45 ft. lbs.) torque. Tighten the stud nuts to 46 N·m (34 ft. lbs.) torque.

(b) LEFT SIDE (Fig. 42) —Tighten the bolts to 61 N·m (45 ft. lbs.) torque.

(2) If the support cushion brackets were removed, position the brackets onto the lower front sill (Fig. 42) (Fig. 44). Install the bolts and stud nuts. Tighten the bolts to 54 N·m (40 ft. lbs.) torque and the stud nuts to 41 N·m (30 ft. lbs.) torque.

REMOVAL AND INSTALLATION (Continued)

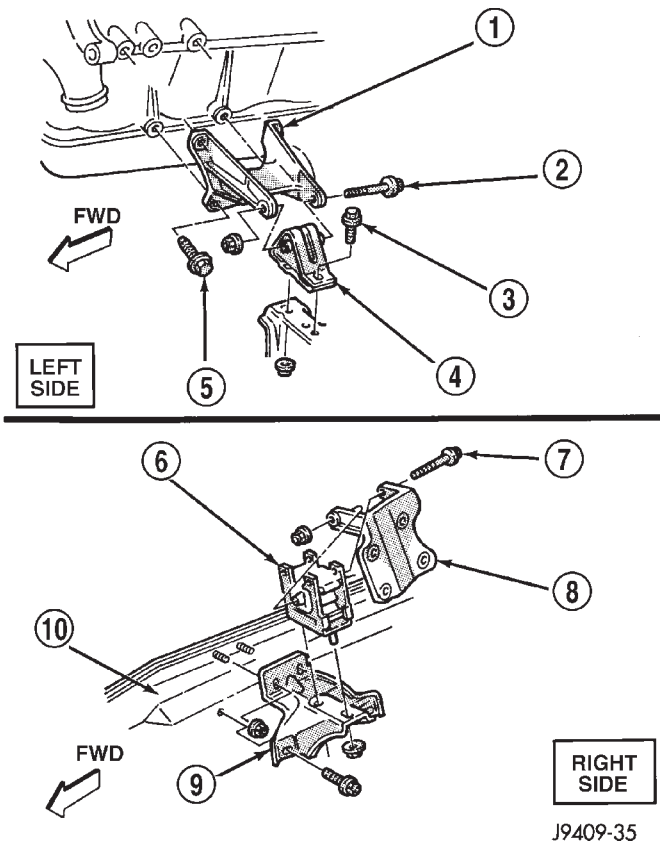
**Fig. 42 Front Mounts**

- 1 - ENGINE SUPPORT BRACKET
- 2 - THROUGH BOLT
- 3 - RETAINING BOLT
- 4 - SUPPORT CUSHION
- 5 - ATTACHING BOLT
- 6 - SUPPORT CUSHION
- 7 - THROUGH BOLT
- 8 - ENGINE SUPPORT BRACKET
- 9 - SUPPORT CUSHION BRACKET
- 10 - SILL

(3) Place the support cushions onto the support cushion brackets (Fig. 42). Tighten the right support cushion nuts to 65 N·m (48 ft. lbs.) torque. Tighten the left support cushion bolt and nut to 41 N·m (30 ft. lbs.) torque.

(4) Install the through bolt and the retaining nut (Fig. 42). Tighten the through bolt nut to 65 N·m (48 ft. lbs.) torque.

(5) Remove the engine support.

(6) Lower the vehicle.

(7) Connect negative cable to battery.

ENGINE MOUNT—REAR

A resilient rubber cushion supports the transmission at the rear between the transmission extension housing and the rear support crossmember or skid plate.

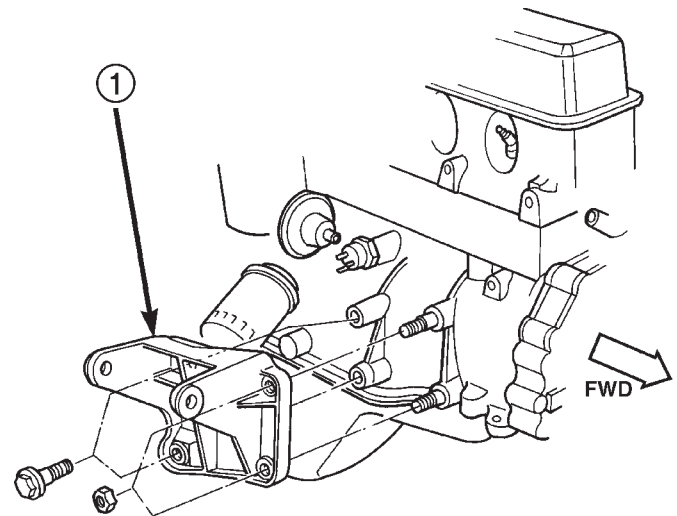

805dd883

Fig. 43 Engine Support Bracket—Right Side

- 1 - ENGINE SUPPORT BRACKET

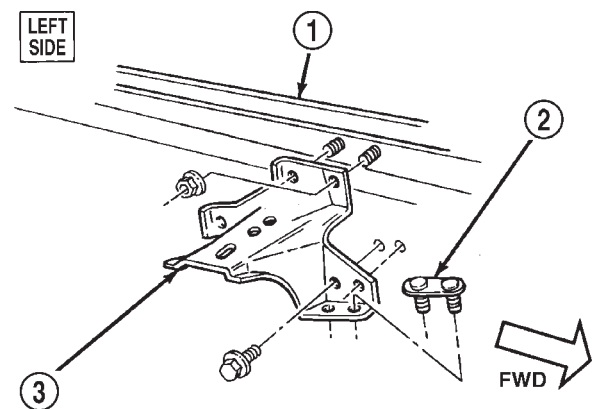

J9409-39

Fig. 44 Support Cushion Bracket—Left Side

- 1 - LOWER FRONT SILL
- 2 - TRACK BAR MOUNTING PLATE
- 3 - SUPPORT CUSHION BRACKET

REMOVAL

- (1) Disconnect negative cable from battery.
- (2) Raise the vehicle and support the transmission.
- (3) Remove the nuts holding the support cushion to the crossmember (Fig. 45) (Fig. 46). Remove the crossmember.

MANUAL TRANSMISSION:

- a. Remove the support cushion nuts and remove the cushion.
- b. If necessary, remove the bolts holding the transmission support bracket to the transmission (Fig. 45). Remove the bracket.

REMOVAL AND INSTALLATION (Continued)

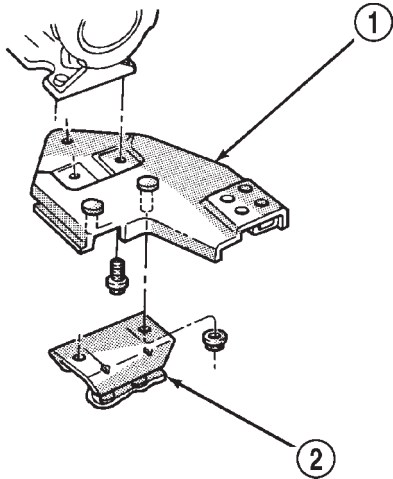

J9409-44

Fig. 45 Rear Mount (Manual Transmission)

- 1 - TRANSMISSION SUPPORT BRACKET
- 2 - SUPPORT CUSHION

AUTOMATIC TRANSMISSION:

- a. Remove the support cushion bolts and remove the cushion and the transmission support bracket.
- b. If necessary on 2WD vehicles, remove the bolts holding the transmission support adaptor bracket to the transmission (Fig. 46). Remove the adaptor bracket.

INSTALLATION

MANUAL TRANSMISSION:

- a. If removed, position the transmission support bracket to the transmission and install the bolts. Tighten the bolts to 43 N·m (32 ft. lbs.) torque.
- b. Position the support cushion onto the transmission support bracket. Install and tighten the nuts to 46 N·m (34 ft. lbs.) torque.

AUTOMATIC TRANSMISSION:

- a. If removed, position the transmission support adaptor bracket (2WD vehicles) to the transmission and install the bolts. Tighten the bolts to 75 N·m (55 ft. lbs.) torque.
- b. Position the transmission support bracket and support cushion to the transmission and install the bolts. Tighten the bolts to 75 N·m (55 ft. lbs.) torque.
- (1) Position the crossmember onto the support cushion studs and install the nuts. Tighten the nuts to 22 N·m (192 in. lbs.) torque.
- (2) Install the crossmember to sill bolts and tighten to 41 N·m (30 ft. lbs.) torque.
- (3) Remove the transmission support.
- (4) Lower the vehicle.
- (5) Connect negative cable to battery.

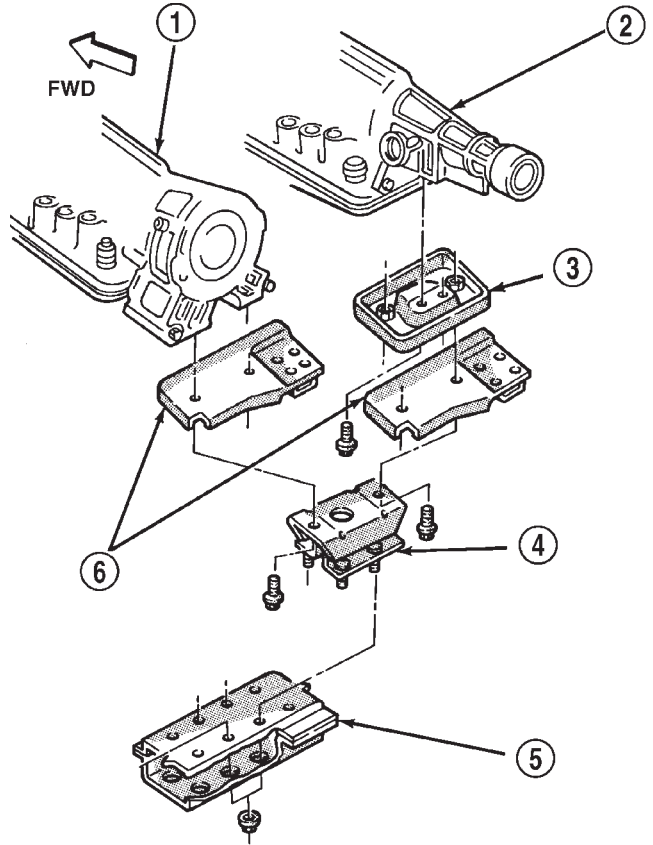

J9409-45

Fig. 46 Rear Mount (Automatic Transmission)

- 1 - 4×4
- 2 - 2×4
- 3 - TRANSMISSION SUPPORT ADAPTOR BRACKET
- 4 - SUPPORT CUSHION
- 5 - CROSSMEMBER ASSEMBLY
- 6 - TRANSMISSION SUPPORT BRACKET

ENGINE

REMOVAL

- (1) Disconnect the battery cables. Remove the battery.
- (2) Mark the hinge locations on the hood panel for alignment reference during installation. Remove the engine compartment lamp. Remove the hood.

WARNING: THE COOLANT IN A RECENTLY OPERATED ENGINE IS HOT AND PRESSURIZED. USE CARE TO PREVENT SCALDING BY HOT COOLANT. CAREFULLY RELEASE THE PRESSURE BEFORE REMOVING THE RADIATOR DRAIN COCK AND CAP.

- (3) Loosen the radiator drain cock and radiator cap to drain the coolant. DO NOT waste usable coolant. If the solution is clean, drain the coolant into a clean container for reuse.
- (4) Remove the air cleaner assembly (Fig. 47).
- (5) Remove the lower radiator hose.

REMOVAL AND INSTALLATION (Continued)

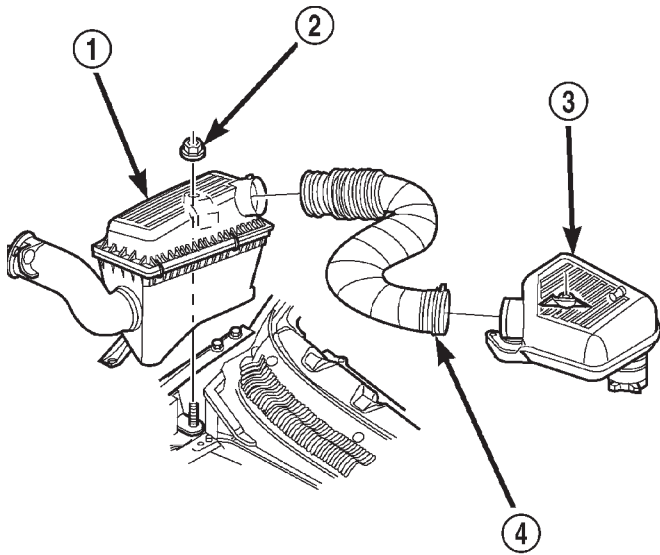

80bcea63

Fig. 47 Air Cleaner and Resonator Removal and Installation

- 1 - AIR CLEANER ASSEMBLY
- 2 - NUT AND WASHER
- 3 - RESONATOR ASSEMBLY
- 4 - AIR INLET HOSE

(6) Remove the upper radiator hose and coolant recovery hose (Fig. 48).

(7) Remove the fan shroud (Fig. 48).



Fig. 48 Upper Radiator Hose, Coolant Recovery Hose & Fan Shroud

- 1 - UPPER RADIATOR HOSE
- 2 - FAN SHROUD
- 3 - COOLANT RECOVERY HOSE

(8) Remove the radiator/condenser (if equipped with air conditioning).

(9) Remove fan assembly and install a 5/16 x 1/2-inch SAE capscrew through fan pulley into water pump flange. This will maintain the pulley and water pump in alignment when crankshaft is rotated.

(10) Disconnect the heater hoses.

(11) Disconnect the throttle cable, speed control cable (if equipped) and transmission cable (if equipped).

(12) Disconnect the body ground at the firewall.

(13) Disconnect the wires from the starter motor solenoid.

(14) Disconnect all fuel injection harness connections.

WARNING: THE FUEL SYSTEM IS UNDER A CONSTANT PRESSURE (EVEN WITH THE ENGINE TURNED OFF). BEFORE DISCONNECTING FUEL LINES, THE FUEL SYSTEM PRESSURE MUST BE RELEASED.

(15) Perform fuel pressure release procedure. (refer to Group 14, Fuel System for the proper procedure).

(16) Remove latch clip and disconnect the quick-connect fuel line at the fuel rail

(17) Recover refrigerant (if equipped with A/C). (Refer to group 24, Heating and Air Conditioning for proper procedures.)

(18) Disconnect suction/discharge hose from A/C compressor and cap off ports to prevent intrusion of foreign material or refrigerant oil loss.

(19) Remove the power brake vacuum check valve from the booster, if equipped.

(20) If equipped with power steering :

(a) Disconnect the power steering hoses from the fittings at the steering gear.

(b) Drain the pump reservoir.

(c) Cap the fittings on the hoses and steering gear to prevent foreign material from entering the system.

(21) Identify, tag and disconnect all necessary wire connectors and vacuum hoses.

(22) Raise the vehicle.

(23) Remove the oil filter.

(24) Remove the starter motor.

(25) Disconnect the exhaust pipe from the exhaust manifold.

(26) Remove the flywheel housing access cover.

(27) Remove the upper flywheel and converter housing bolts and loosen the bottom bolts.

(28) Remove the engine support cushion-to-engine compartment bracket bolts.

(29) Remove the engine shock damper bracket from the sill.

(30) Lower the vehicle.

(31) Attach a lifting device to the engine.

REMOVAL AND INSTALLATION (Continued)

(32) Raise the engine slightly off the front supports.

(33) Place a support stand under the converter or flywheel housing.

(34) Lift the engine out of the engine compartment and install on an engine stand.

(35) Install the oil filter to keep foreign material out of the engine.

INSTALLATION

(1) Remove the oil filter.

(2) Lift the engine off the stand and lower it into the engine compartment. For easier installation, it may be useful to remove the engine support cushions from the engine support brackets as an aide for alignment of the engine-to-transmission.

(3) Insert the transmission shaft into the clutch spline. (M/T models)

(4) Align the flywheel housing with the engine.

(5) Install and tighten the flywheel housing lower bolts.

(6) Install the engine support cushions (if removed).

(7) Lower the engine and engine support cushions onto the engine compartment brackets.

(8) Remove the engine lifting device.

(9) Raise the vehicle.

(10) Install the converter-housing access cover.

(11) Install the exhaust pipe support.

(12) Install the starter motor and connect the cable. Tighten the bolts to 45 N·m (33 ft. lbs.) torque.

(13) Tighten the engine support cushion through-bolt nuts.

(14) Connect the exhaust pipe to the manifold.

(15) Install the oil filter.

(16) Lower the vehicle.

(17) Connect the coolant hoses and tighten the clamps.

(18) If equipped with power steering:

(a) Remove the protective caps

(b) Connect the hoses to the fittings at the steering gear. Tighten the nut to 52 N·m (38 ft. lbs.) torque.

(c) Fill the pump reservoir with fluid.

(19) Remove the pulley-to-water pump flange alignment capscrew and install the fan assembly.

(20) Install the fan shroud and radiator and condenser (if equipped with air conditioning).

(21) Connect the radiator hoses.

(22) Connect the oxygen sensor wire connector.

(23) Connect the throttle cable and install the rod. Connect the transmission and speed control cables (if equipped)

(24) Connect the fuel supply line to the injector rail. push until a "click" is heard. Re-install latch clip.

(25) Connect all the vacuum hoses and wire connectors.

(26) Connect suction/discharge hose to compressor. (if equipped)

(27) Fill the power steering reservoir.

(28) Connect the battery cables.

(29) Install the air cleaner (Fig. 47).

(30) Install the hood.

(31) Add engine oil and coolant.

(32) Start the engine and inspect for leaks.

(33) Stop the engine and check the fluid levels.

Add fluid, as required.

(34) Recharge air conditioning (Refer to group 24, Heating and Air Conditioning for proper procedures).

INTAKE MANIFOLD**REMOVAL**

(1) Disconnect the battery negative cable.

(2) Remove the air inlet hose and resonator from the throttle body and air cleaner (Fig. 49).

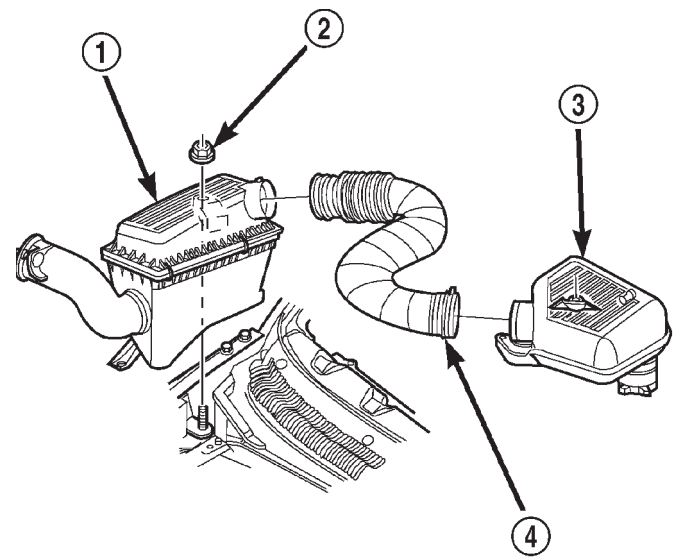

80bcea63

Fig. 49 Air Cleaner, Resonator and air Inlet Hose Removal and Installation

1 - AIR CLEANER ASSEMBLY

2 - NUT AND WASHER

3 - RESONATOR ASSEMBLY

4 - AIR INLET HOSE

(3) Loosen the accessory drive belt tension and remove the belt from the power steering pump (refer to Group 07, Cooling Systems for proper procedures).

(4) Remove the power steering pump and brackets from the water pump and intake manifold. Secure power steering pump and bracket out of the way.

REMOVAL AND INSTALLATION (Continued)

(5) Perform fuel system pressure release procedure (refer to Group 14, Fuel System for correct procedure).

(6) Disconnect fuel supply tube from the fuel rail. Some fuel lines require a special tool for removal/installation (refer to Group 14, Fuel System - Quick Connect Fittings).

(7) Disconnect the accelerator cable, the cruise control cable (if equipped), and the transmission line pressure cable (if equipped) from the throttle body and remove them from the cable bracket.

CAUTION: When disconnecting the cruise control connector at the throttle body, **DO NOT** pry the connector off with pliers or screwdriver. Use finger pressure only. Prying the connector off could break it.

(8) Disconnect the electrical connectors. Pull the harnesses away from the manifold and secure them so they do not interfere with the manifold removal and installation process.

- The throttle position sensor.
- The idle air control motor.
- The coolant temperature sensor at the thermostat.
- The manifold air temperature sensor at the intake manifold.
- The fuel injectors.
- The oxygen sensor.

(9) Disconnect the crankcase ventilation (CCV) vacuum hose and manifold absolute pressure (MAP) sensor vacuum hose connector at the intake manifold.

(10) Disconnect vacuum hose from vacuum port on the intake manifold.

(11) Disconnect CCV hose at the cylinder head cover (Fig. 50).

(12) Remove the molded vacuum harness.

(13) Disconnect the vacuum brake booster hose at the intake manifold.

(14) Remove bolts 2 through 5 securing the intake manifold to the cylinder head (Fig. 51). Slightly loosen bolt No.1 and nuts 6 and 7.

(15) Remove the intake manifold and gaskets. Drain the coolant from the manifold.

INSTALLATION

(1) Clean the intake manifold and cylinder head mating surfaces. **DO NOT allow foreign material to enter either the intake manifold or the ports in the cylinder head.**

(2) Install the new intake manifold gasket over the locating dowels.

(3) Position the manifold in place and finger tighten the mounting bolts.

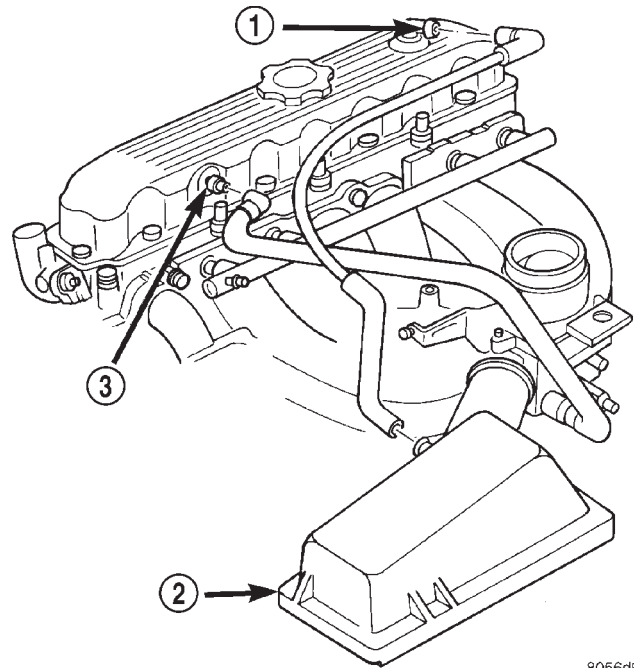

8056d9f4

Fig. 50 Crankcase Ventilation (CCV) Hose—2.5L Engine

- 1 - AIR INLET FITTING
- 2 - AIR FILTER COVER
- 3 - FIXED ORIFICE FITTING

(4) Tighten the fasteners in sequence and to the specified torque (Fig. 51).

- Fastener No.1—Tighten to 41 N·m (30 ft. lbs.) torque.
- Fasteners Nos.2 through 5—Tighten to 31 N·m (23 ft. lbs.) torque.
- Fasteners Nos.6 and 7—Tighten to 23 N·m (17 ft. lbs.) torque.

(5) Connect fuel supply tube to the fuel rail inlet. Push tube until a “click” is heard. **Before connecting the fuel line to the fuel rail replace the O-rings at the quick-connect fuel line coupling.**

(6) Pull out on the fuel supply tube to ensure that it is locked in place.

(7) Connect the molded vacuum hoses to the vacuum port on the intake manifold and the cylinder head cover.

(8) Connect the electrical connectors.

- The throttle position sensor.
- The idle air control motor.
- The coolant temperature sensor at the thermostat housing.
- The fuel injectors.
- The air manifold temperature sensor.
- The oxygen sensor.

(9) Connect the CCV vacuum hose and MAP sensor vacuum hose connectors to the throttle body.

REMOVAL AND INSTALLATION (Continued)

(10) Install the power steering pump and bracket assembly to the water pump and intake manifold. Hand start the three (3) tensioner bracket to p/s pump to intake manifold bolts and the two (2) tensioner bracket to water pump bolts.

(11) Tighten the power steering pump bolts to 28 N·m (21 ft. lbs.) Tighten the tensioner bracket to water pump bolts to 28 N·m (21 ft. lbs.).

(12) Connect the accelerator cable, cruise control cable (if equipped), and the transmission line pressure cable (if equipped) to the hold-down bracket and the throttle lever.

(13) Install and tension the accessory drive belt. Refer to Group 7, Cooling System for the proper procedure.

CAUTION: Ensure that the accessory drive belt is routed correctly. Failure to do so can cause the water pump to turn in the opposite direction resulting in engine overheating. Refer to Group 7, Cooling System for the proper procedure.

(14) Connect the air inlet hose and resonator to the throttle body and the air cleaner.

(15) Connect the battery negative cable.

(16) Start the engine and check for leaks.

EXHAUST MANIFOLD

REMOVAL

(1) Disconnect the battery negative cable.

(2) Raise the vehicle.

(3) Disconnect the exhaust pipe from the engine exhaust manifold.

(4) Lower the vehicle.

(5) Remove intake manifold (refer to procedure in this section)

(6) Remove fasteners 2 through 5 and remove the intake manifold (Fig. 51).

(7) Remove fasteners 1, 6 and 7 and remove the engine exhaust manifold (Fig. 51).

INSTALLATION

(1) Clean the intake and engine exhaust manifolds and cylinder head mating surfaces. **DO NOT allow foreign material to enter either the intake manifold or the ports in the cylinder head.**

(2) Install a new intake manifold gasket over the alignment dowels on the cylinder head.

(3) Install the engine exhaust manifold assembly. **Exhaust manifold must be centrally located over the end studs and spacer (Fig. 51).**

(4) Tighten bolt No.1 to 41 N·m (30 ft. lbs.) torque (Fig. 51).

(5) Install the intake manifold on the cylinder head dowels (Fig. 51).

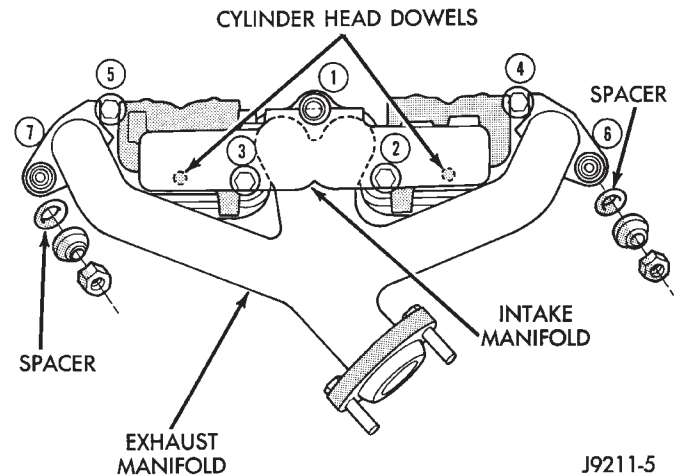

Fig. 51 Intake/Exhaust Manifold Removal/Installation—2.5L Engine

(6) Install bolts 2 through 5 (Fig. 51). Tighten these bolts to 31 N·m (23 ft. lbs.) torque.

(7) Install new engine exhaust manifold spacers over the engine exhaust manifold mounting studs in the cylinder head (Fig. 51).

(8) Tighten nuts 6 and 7 to 23 N·m (17 ft. lbs.) torque (Fig. 51).

(9) Install all components to the intake manifold.

(10) Raise the vehicle.

(11) Connect the exhaust pipe to the engine exhaust manifold. Tighten the bolts to 31 N·m (23 ft. lbs.) torque.

(12) Lower the vehicle.

(13) Connect the battery negative cable.

(14) Start the engine and check for leaks.

CYLINDER HEAD COVER

A cured gasket is part of the engine cylinder head cover.

REMOVAL

(1) Disconnect negative cable from battery.

(2) Disconnect the Crankcase Ventilation (CCV) vacuum hose from engine cylinder head cover (Fig. 52).

(3) Remove the air inlet hose and resonator from the air cleaner and throttle body.

(4) Remove the engine cylinder head cover mounting bolts.

(5) Remove the engine cylinder head cover (Fig. 52).

(6) Remove any original sealer from the cover sealing surface of the engine cylinder head and clean the surface using a fabric cleaner.

(7) Remove all residue from the sealing surface using a clean, dry cloth.

REMOVAL AND INSTALLATION (Continued)

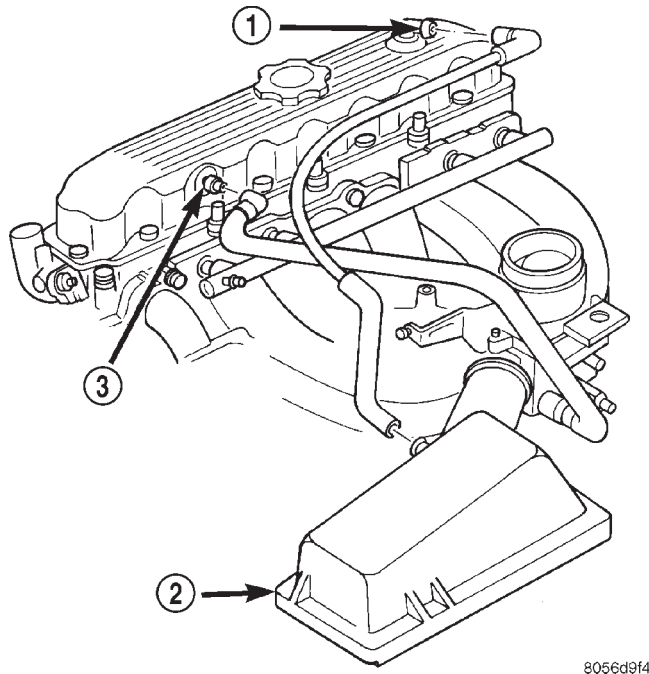

8056d9f4

Fig. 52 Engine Cylinder Head Cover

- 1 - AIR INLET FITTING
- 2 - AIR FILTER COVER
- 3 - FIXED ORIFICE FITTING

INSTALLATION

(1) Inspect the engine cylinder head cover for cracks. Replace the cover, if cracked.

NOTE: The original dark grey gasket material should NOT be removed. If sections of the gasket material are missing or are compressed, replace the engine cylinder head cover. However, sections with minor damage such as small cracks, cuts or chips may be repaired with a hand held applicator. The new material must be smoothed over to maintain gasket height. Allow the gasket material to cure prior to engine cylinder head cover installation.

(2) If a replacement cover is installed, transfer the CCV valve grommet the oil filler cap from the original cover to the replacement cover.

(3) Install engine cylinder head cover. Tighten the mounting bolts to 13 N·m (115 in. lbs.) torque.

(4) Connect the CCV hoses (Fig. 52).

(5) Connect negative cable to battery.

(6) Install the air inlet hose and resonator.

ROCKER ARMS AND PUSH RODS

This procedure can be done with the engine in or out of the vehicle.

REMOVAL

(1) Remove the engine cylinder head cover. (Refer to procedure in this section)

(2) Check for rocker arm bridges which are causing misalignment of the rocker arm to valve tip area.

(3) Remove the capscrews at each bridge and pivot assembly (Fig. 53). Alternately loosen the capscrews one turn at a time to avoid damaging the bridges.

(4) Remove the bridges, pivots and corresponding pairs of rocker arms (Fig. 53). Place them on a bench in the same order as removed.

(5) Remove the push rods and place them on a bench in the same order as removed.

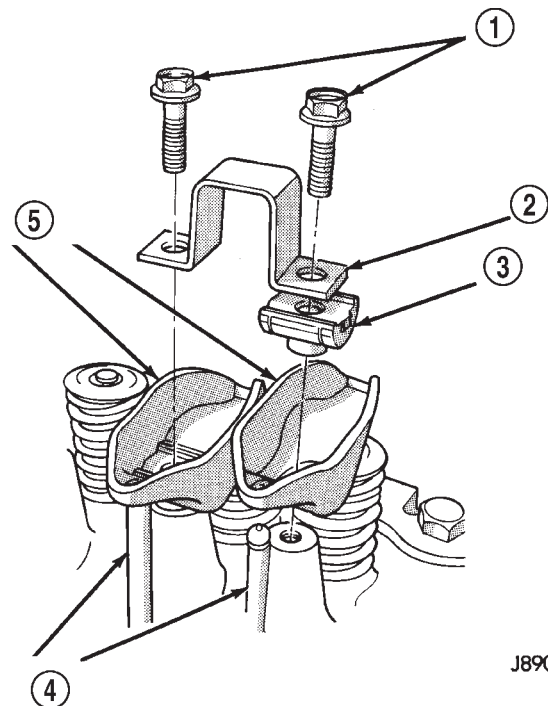

J8909-8

Fig. 53 Rocker Arm Assembly

- 1 - CAPSCREWS
- 2 - BRIDGE
- 3 - PIVOT ASSEMBLY
- 4 - PUSH RODS
- 5 - ROCKER ARMS

(6) Clean all the components with cleaning solvent.

(7) Use compressed air to blow out the oil passages in the rocker arms and push rods.

INSTALLATION

(1) Lubricate the ball ends of the push rods with Mopar Engine Oil Supplement, or equivalent and install push rods in their original locations. Ensure that the bottom end of each push rod is centered in the tappet plunger cap seat.

(2) Using Mopar Engine Oil Supplement, or equivalent, lubricate the area of the rocker arm that the

REMOVAL AND INSTALLATION (Continued)

pivot contacts. Install rocker arms, pivots and bridge above each cylinder in their original position.

(3) Loosely install the capscrews through each bridge.

(4) At each bridge, tighten the capscrews alternately, one turn at a time, to avoid damaging the bridge. Tighten the capscrews to 28 N·m (21 ft. lbs.) torque.

(5) Install the engine cylinder head cover.

VALVE SPRING AND SEAL

This procedure can be done with the engine cylinder head installed on the block.

REMOVAL

Each valve spring is held in place by a retainer and a set of conical valve locks. The locks can be removed only by compressing the valve spring.

(1) Remove the engine cylinder head cover. Refer to procedure in this section.

(2) Remove cap screws, bridge and pivot assemblies and rocker arms for access to each valve spring to be removed.

(3) Remove push rods. **Retain the push rods, bridges, pivots and rocker arms in the same order and position as removed.**

(4) Inspect the springs and retainer for cracks and possible signs of weakening.

(5) Remove the spark plug(s) adjacent to the cylinder(s) below the valve springs to be removed.

(6) Install a 14 mm (1/2 inch) (thread size) air hose adaptor in the spark plug hole.

(7) Connect an air hose to the adapter and apply air pressure slowly. Maintain at least 621 kPa (90 psi) of air pressure in the cylinder to hold the valves against their seats. For vehicles equipped with an air conditioner, use a flexible air adaptor when servicing the No.1 cylinder.

(8) Tap the retainer or tip with a rawhide hammer to loosen the lock from the retainer. Use Valve Spring Compressor Tool MD-998772A to compress the spring and remove the locks (Fig. 54).

(9) Remove valve spring and retainer (Fig. 54).

(10) Remove valve stem oil seals (Fig. 54). Note the valve seals are different for intake and exhaust valves. The top of each seal is marked either INT (intake/black in color) or EXH (exhaust/brown in color). DO NOT mix the seals.

INSTALLATION

Inspect the valve stems, especially the grooves. An Arkansas smooth stone should be used to remove nicks and high spots.

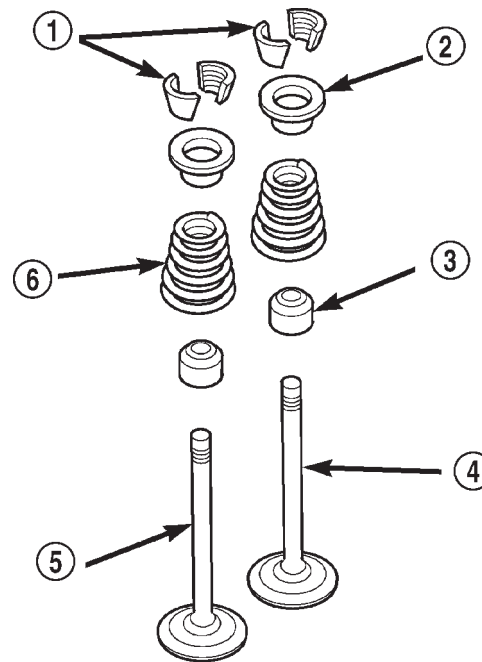

80b7704b

Fig. 54 Valve and Valve Components

- 1 - VALVE LOCKS (3-BEAD)
- 2 - RETAINER
- 3 - VALVE STEM OIL SEAL
- 4 - INTAKE VALVE
- 5 - EXHAUST VALVE
- 6 - VALVE SPRING

CAUTION: Install oil seals carefully to prevent damage from the sharp edges of the valve spring lock groove.

(1) Lightly push the valve seal over the valve stem and valve guide boss. Be sure the seal is completely seated on the valve guide boss.

(2) Install valve spring and retainer.

(3) Compress the valve spring with Valve Spring Compressor Tool MD-998772A and insert the valve locks. Release the spring tension and remove the tool. Tap the spring from side-to-side to ensure that the spring is seated properly on the engine cylinder head.

(4) Release air pressure and disconnect the air hose. Remove the adaptor from the spark plug hole and install the spark plug.

(5) Repeat the procedures for each remaining valve spring to be removed.

(6) Install the push rods. Ensure the bottom end of each rod is centered in the plunger cap seat of the hydraulic valve tappet.

(7) Install the rocker arms, pivots and bridge at their original location.

(8) Tighten the bridge cap screws alternately, one at a time, to avoid damaging the bridge. Tighten the cap screws to 28 N·m (21 ft. lbs.) torque.

REMOVAL AND INSTALLATION (Continued)

(9) Install the engine cylinder head cover.

CYLINDER HEAD

This procedure can be done with the engine in or out of the vehicle.

REMOVAL

(1) Disconnect negative cable from battery.

WARNING: DO NOT REMOVE THE CYLINDER BLOCK DRAIN PLUGS OR LOOSEN THE RADIATOR DRAIN COCK WITH THE SYSTEM HOT AND PRESSURIZED BECAUSE SERIOUS BURNS FROM THE COOLANT CAN OCCUR.

(2) Drain the coolant and disconnect the hoses at the engine thermostat housing. **DO NOT** waste reusable coolant. If the solution is clean and is being drained only to service the engine or cooling system, drain the coolant into a clean container for reuse.

(3) Remove the air cleaner assembly.

(4) Remove the engine cylinder head cover. (Refer to procedure in this section)

(5) Remove the capscrews, bridge and pivot assemblies and rocker arms (Fig. 55).

(6) Remove the push rods (Fig. 55). **Retain the push rods, bridges, pivots and rocker arms in the same order as removed.**

(7) Loosen the accessory drive belt at the power steering pump bracket, if equipped or at the idler pulley bracket (refer to Group 7, Cooling System for the proper procedure).

(8) If equipped with air conditioning, perform the following:

(a) Remove the bolts from the A/C compressor mounting bracket and set the compressor aside.

(b) Remove the air conditioner compressor bracket bolts from the engine cylinder head.

(c) Loosen the through bolt at the bottom of the bracket.

(9) If equipped, disconnect the power steering pump bracket. Set the pump and bracket aside. **DO NOT** disconnect the hoses.

(10) Perform fuel pressure release procedure (Refer to Group 14, fuel systems for proper procedures).

(11) Remove the latch clip and disconnect the fuel supply hose.

(12) Remove the intake and engine exhaust manifolds from the engine cylinder head (refer to Group 11, Exhaust System and Intake Manifold for the proper procedures).

(13) Number and disconnect the ignition wires and remove the spark plugs.

(14) Disconnect the coolant temperature sending unit connector.

(15) Remove the engine cylinder head bolts.

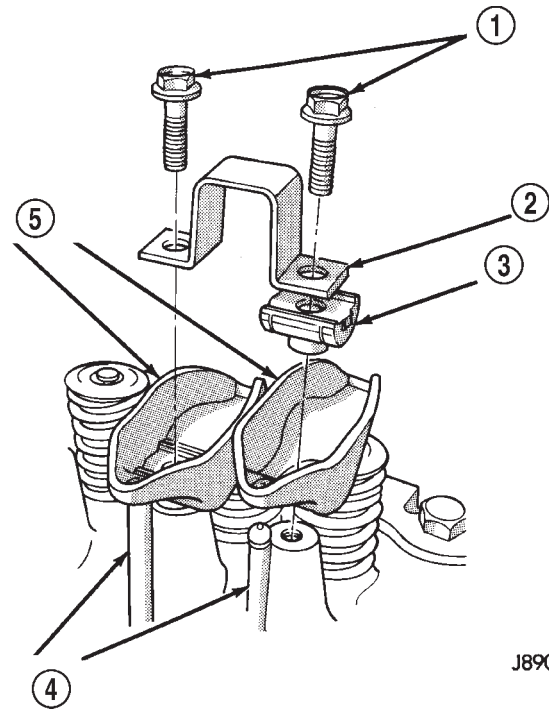

J8909-8

Fig. 55 Rocker Arm Assembly

- 1 - CAPSCREWS
- 2 - BRIDGE
- 3 - PIVOT ASSEMBLY
- 4 - PUSH RODS
- 5 - ROCKER ARMS

(16) Remove the engine cylinder head and gasket (Fig. 56).

(17) If this was the first time the bolts were removed, put a paint dab on the top of the bolt. If the bolts have a paint dab on the top of the bolt or it isn't known if they were used before, discard the bolts.

(18) Stuff clean lint free shop towels into the cylinder bores.

NOTE: If valves, springs, or seals are to be inspected/replaced at this time, refer to Valves and Valve Springs later in this section for proper inspection procedures.

INSTALLATION

The engine cylinder head gasket is a composition gasket. The gasket is to be installed **DRY**. **DO NOT use a gasket sealing compound on the gasket.**

If the engine cylinder head is to be replaced and the original valves used, measure the valve stem diameter. Only standard size valves can be used with a service replacement engine cylinder head unless the replacement head valve stem guide bores are reamed to accommodate oversize valve stems. Remove all carbon buildup and reface the valves.

REMOVAL AND INSTALLATION (Continued)

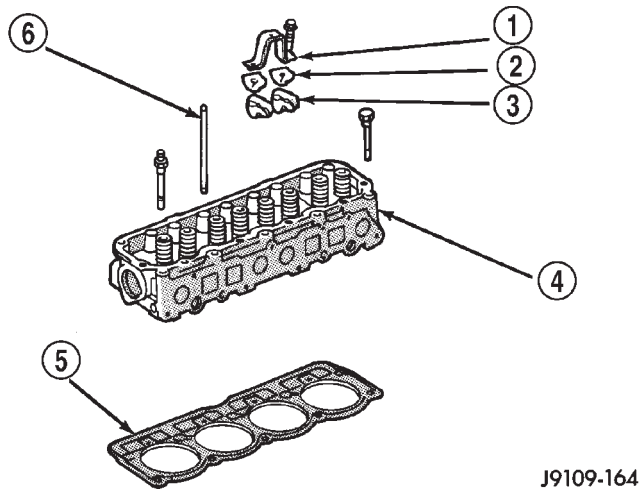
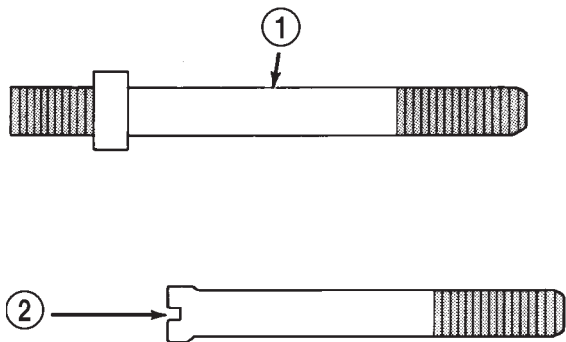

Fig. 56 Engine Cylinder Head Assembly

- 1 - BRIDGE
- 2 - PIVOT ASM.
- 3 - ROCKER ARM
- 4 - CYLINDER HEAD
- 5 - HEAD GASKET
- 6 - PUSH ROD

(1) Fabricate two engine cylinder head alignment dowels from used head bolts (Fig. 57). Use the longest head bolt. Cut the head of the bolt off below the hex head. Then cut a slot in the top of the dowel to allow easier removal with a screwdriver.



J9009-13

Fig. 57 Fabricate Alignment Dowels

- 1 - USED CYLINDER HEAD BOLT
- 2 - SLOT

(2) Install one dowel in bolt hole No.10 and the other dowel in bolt hole No.8 (Fig. 58).
 (3) Remove the shop towels from the cylinder bores. Coat the bores with clean engine oil.
 (4) Place the engine cylinder head gasket (with the numbers facing up) over the dowels.
 (5) Place the engine cylinder head over the dowels.

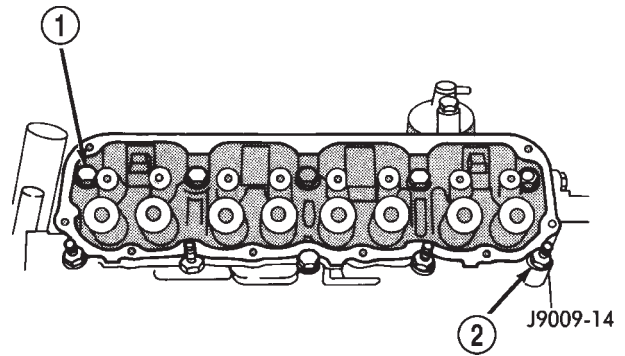

Fig. 58 Alignment Dowel Locations

- 1 - ALIGNMENT DOWEL
- 2 - ALIGNMENT DOWEL

CAUTION: Engine cylinder head bolts should be reused only once. Replace the head bolts if they were used before or if they have a paint dab on the top of the bolt.

- (6) Coat the threads of bolt No.7, only, with Loctite PST sealant or equivalent.
- (7) Install all head bolts, except No.8 and No.10.
- (8) Remove the dowels.
- (9) Install No.8 and No.10 head bolts.

CAUTION: During the final tightening sequence, bolt No.7 will be tightened to a lower torque than the rest of the bolts. DO NOT overtighten bolt No.7.

(10) Tighten the engine cylinder head bolts in sequence according to the following procedure (Fig. 59) :

- (a) Tighten all bolts in sequence (1 through 10) to 30 N·m (22 ft. lbs.) torque.
- (b) Tighten all bolts in sequence (1 through 10) to 61 N·m (45 ft. lbs.) torque.
- (c) Check all bolts to verify they are set to 61 N·m (45 ft. lbs.) torque.
- (d) Tighten bolts (in sequence):
 - Bolts 1 through 6 to 149 N·m (110 ft. lbs.) torque.
 - Bolt 7 to 136 N·m (100 ft. lbs.) torque.
 - Bolts 8 through 10 to 149 N·m (110 ft. lbs.) torque.

(e) Check all bolts in sequence to verify the correct torque.

(f) If not already done, clean and mark each bolt with a dab of paint after tightening. Should you encounter bolts which were painted in an earlier service operation, replace them.

(11) Connect the coolant temperature sending unit connector.

(12) Install the spark plugs and tighten to 37 N·m (27 ft. lbs.) torque. Connect the ignition wires.

REMOVAL AND INSTALLATION (Continued)

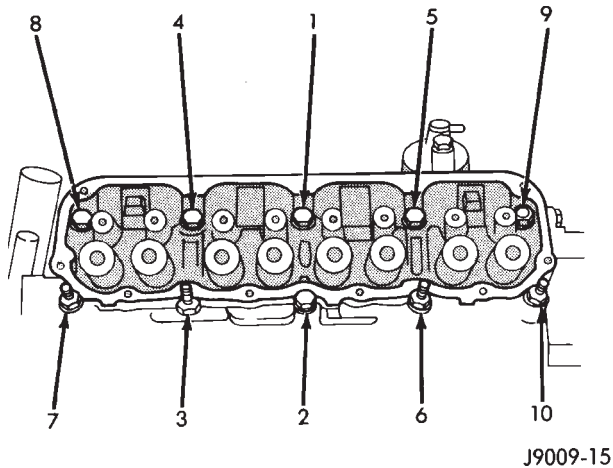

Fig. 59 Engine cylinder head Bolt Tightening Sequence

(13) Install the intake and exhaust manifolds (refer to Group 11, Exhaust System and Intake Manifold for the proper procedures).

(14) Install the fuel supply line. Push until a "click" is heard. Reinstall latch clip.

(15) If equipped, attach the power steering pump and bracket.

(16) Install the push rods, rocker arms, pivots and bridges in the order they were removed.

(17) Install the engine cylinder head cover.

(18) Attach the air conditioning compressor mounting bracket to the engine cylinder head and block. Tighten the bolts to 40 N·m (30 ft. lbs.) torque.

(19) Attach the air conditioning compressor to the bracket. Tighten the bolts to 27 N·m (20 ft. lbs.) torque.

CAUTION: The accessory drive belt must be routed correctly. Incorrect routing can cause the water pump to turn in the opposite direction causing the engine to overheat.

(20) Install the accessory drive belt and correctly tension the belt (refer to Group 7, Cooling System for the proper procedure).

(21) Install the air cleaner assembly.

(22) Connect the hoses to the thermostat housing and fill the cooling system to the specified level (refer to Group 7, Cooling Systems for the proper procedure).

(23) Install the coolant temperature sending unit connector.

(24) Connect negative cable to battery.

(25) Connect the upper radiator hose and heater hose at the thermostat housing.

(26) Fill the cooling system. Check for leaks.

WARNING: USE EXTREME CAUTION WHEN THE ENGINE IS OPERATING. DO NOT STAND IN DIRECT

LINE WITH THE FAN. DO NOT PUT HANDS NEAR THE PULLEYS, BELTS OR FAN. DO NOT WEAR LOOSE CLOTHING.

(27) Operate the engine with the radiator cap off. Inspect for leaks and continue operating the engine until the thermostat opens. Add coolant, if required.

CYLINDER HEAD

DISASSEMBLY

(1) Use Valve Spring Compressor Tool MD-998772A and compress each valve spring.

(2) Remove the valve locks, retainers, springs and valve stem oil seals. Discard the oil seals.

(3) Use an Arkansas smooth stone or a jewelers file to remove any burrs on the top of the valve stem, especially around the groove for the locks.

(4) Remove the valves, and place them in a rack in the same order as removed.

ASSEMBLY

(1) Thoroughly clean the valve stems and the valve guide bores.

(2) Lightly lubricate the stem.

(3) Install the valve in the original valve guide bore.

(4) Install the replacement valve stem oil seals on the valve stems. If the 0.381 mm (0.015 inch) over-size valve stems are used, oversize oil seals are required.

(5) Position the valve spring and retainer on the engine cylinder head and compress the valve spring with Valve Spring Compressor Tool MD-998772A.

(6) Install the valve locks and release the tool.

(7) Tap the valve spring from side to side with a hammer to ensure that the spring is properly seated at the engine cylinder head. Also tap the top of the retainer to seat the valve locks.

HYDRAULIC TAPPETS

REMOVAL

Retain all the components in the same order as removed.

(1) Remove the engine cylinder head cover (refer to procedure earlier in this section)

(2) Remove the bridge and pivot assemblies and rocker arms by removing the capscrews at each bridge. Alternately loosen each capscrew, one turn at a time, to avoid damaging the bridges.

(3) Remove the push rods.

(4) Remove the tappets through the push rod openings in the cylinder head with a Hydraulic Valve Tappet Removal/Installation Tool (Fig. 60).

REMOVAL AND INSTALLATION (Continued)

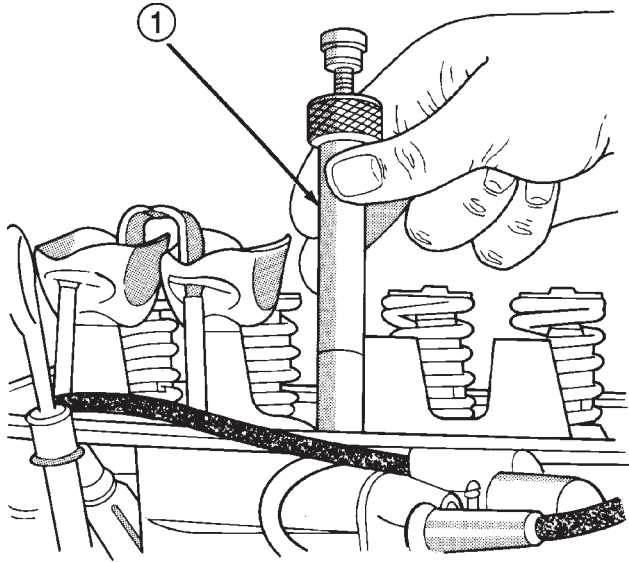

J8909-96

Fig. 60 Hydraulic Valve Tappet Removal/Installation Tool

1 - HYDRAULIC VALVE TAPPET REMOVAL/INSTALLATION TOOL

INSTALLATION

It is not necessary to charge the tappets with engine oil. They will charge themselves within a very short period of engine operation.

(1) Dip each tappet in Mopar Engine Oil Supplement, or equivalent.

(2) Use Hydraulic Valve Tappet Removal/Installation Tool to install each tappet in the same bore from where it was originally removed.

(3) Install the push rods in their original locations.

(4) Install the rocker arms and bridge and pivot assemblies at their original locations. Loosely install the capscrews at each bridge.

(5) Tighten the capscrews alternately, one turn at a time, to avoid damaging the bridges. Tighten the capscrews to 28 N·m (21 ft. lbs.) torque.

(6) Install the engine cylinder head cover.

VIBRATION DAMPER

REMOVAL

(1) Disconnect negative cable from battery.

(2) Remove the serpentine drive belt and fan shroud.

(3) Remove the vibration damper retaining bolt and washer.

(4) Use Vibration Damper Removal Tool 7697 to remove the damper from the crankshaft (Fig. 61).

INSTALLATION

(1) Apply Mopar Silicone Rubber Adhesive Sealant to the keyway in the crankshaft and insert the key.

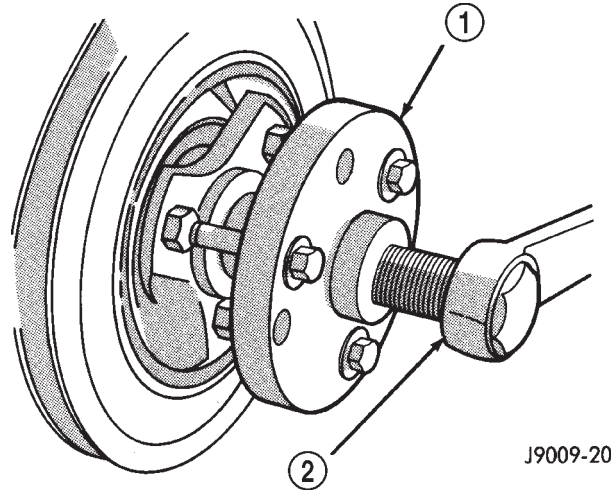

J9009-20

Fig. 61 Vibration Damper Removal Tool 7697

1 - VIBRATION DAMPER REMOVAL TOOL

2 - WRENCH

With the key in position, align the keyway on the vibration damper hub with the crankshaft key and tap the damper onto the crankshaft.

(2) Install the vibration damper retaining bolt and washer.

(3) Tighten the damper retaining bolt to 108 N·m (80 ft. lbs.) torque.

(4) Install the serpentine drive belt and tighten to the specified tension (refer to Group 7, Cooling Systems for the proper specifications and procedures).

(5) Connect negative cable to battery.

TIMING CASE COVER OIL SEAL

REMOVAL

This procedure is done with the timing case cover installed.

(1) Disconnect negative cable from battery.

(2) Remove the serpentine drive belt.

(3) Remove the vibration damper.

(4) Remove the radiator shroud.

(5) Carefully remove the oil seal. Make sure seal bore is clean.

INSTALLATION

(1) Position the replacement oil seal on Timing Case Cover Alignment and Seal Installation Tool 6139 with seal open end facing inward. Apply a light film of Perfect Seal, or equivalent, on the outside diameter of the seal. Lightly coat the crankshaft with engine oil.

(2) Position the tool and seal over the end of the crankshaft and insert a draw screw tool into Seal Installation Tool 6139 (Fig. 62). Tighten the nut against the tool until it contacts the cover.

REMOVAL AND INSTALLATION (Continued)

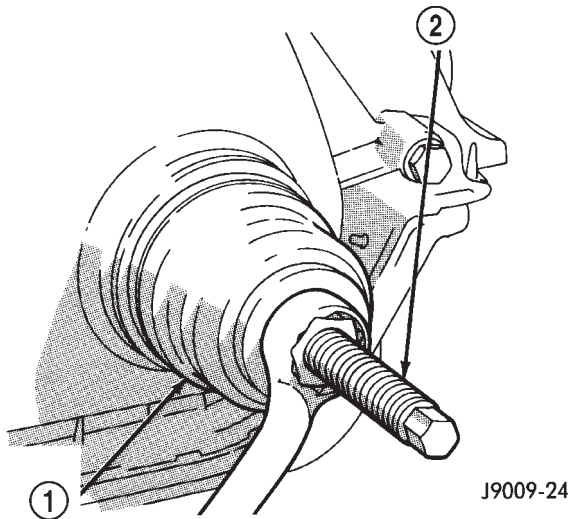
**Fig. 62 Timing Case Cover Oil Seal Installation**

- 1 - SEAL INSTALLATION TOOL
- 2 - DRAW SCREW TOOL

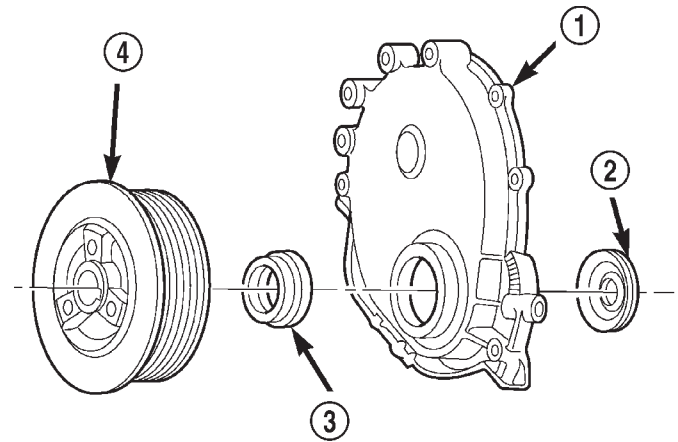
**Fig. 63 Timing Case Cover Components**

- 1 - TIMING CASE COVER
- 2 - OIL SLINGER
- 3 - CRANKSHAFT OIL SEAL
- 4 - VIBRATION DAMPER PULLEY

(3) Remove the tools. Apply a light film of engine oil on the vibration damper hub contact surface of the seal.

(4) Apply Mopar Silicone Rubber Adhesive Sealant to the keyway in the crankshaft and insert the key. With the key inserted in the keyway in the crankshaft, install the vibration damper, washer and bolt. Lubricate and tighten the bolt to 108 N·m (80 ft. lbs.) torque.

(5) Install the serpentine belt and tighten to the specified tension (refer to Group 7, Cooling Systems for the proper specifications and procedures).

(6) Install the radiator shroud.

(7) Connect negative cable to battery.

TIMING CASE COVER**REMOVAL**

(1) Disconnect battery negative cable.

(2) Remove accessory drive belt (Refer to Group 07, Cooling System for proper procedure)

(3) Remove the accessory drive brackets that are attached to the timing case cover.

(4) Remove the fan and hub assembly and remove the fan shroud.

(5) Remove the A/C compressor (if equipped) and generator bracket assembly from the engine cylinder head and move to one side.

(6) Remove the vibration damper (Fig. 63).

(7) Remove the oil pan-to-timing case cover bolts and timing case cover-to-cylinder block bolts.

(8) Remove the timing case cover and gasket from the engine.

(9) Pry the crankshaft oil seal from the front of the timing case cover (Fig. 63).

INSTALLATION

(1) Clean the timing case cover, oil pan and cylinder block gasket surfaces.

(2) Install a new crankshaft oil seal in the timing case cover. The open end of the seal should be toward the inside of the cover. Support the cover at the seal area while installing the seal. Force it into position with Seal Installation Tool 6139.

(3) Position the gasket on the cylinder block.

(4) Position the timing case cover on the oil pan gasket and the cylinder block.

(5) Insert Timing Case Cover Alignment and Seal Installation Tool 6139 in the crankshaft opening in the cover (Fig. 64).

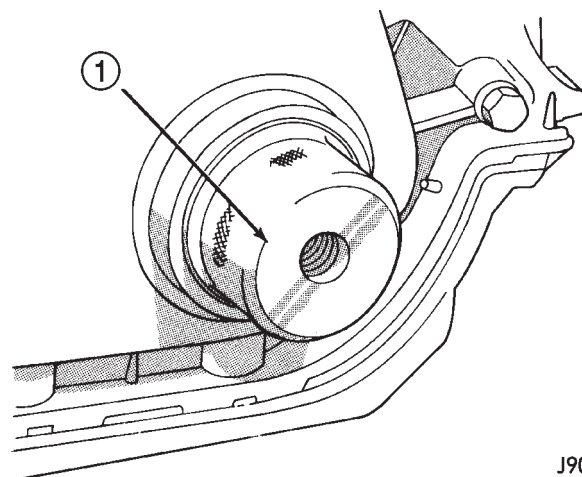
**Fig. 64 Timing Case Cover Alignment and Seal Installation Tool 6139**

- 1 - TIMING CASE COVER ALIGNMENT AND SEAL INSTALLATION TOOL

REMOVAL AND INSTALLATION (Continued)

(6) Install the timing case cover-to-cylinder block and the oil pan-to-timing case cover bolts.

(7) Tighten the 1/4 inch cover-to-block bolts to 7 N·m (60 in. lbs.) torque. Tighten the 5/16 inch front cover-to-block bolts to 22 N·m (192 in. lbs.) torque. Tighten the oil pan-to-cover bolts to 9.5 N·m (84 in. lbs.) torque.

(8) Remove the cover alignment tool.

(9) Apply a light film of engine oil on the vibration damper hub contact surface of the seal.

(10) Apply Mopar Silicone Rubber Adhesive Sealant to the keyway in the crankshaft and insert the key. With the key inserted in the keyway in the crankshaft, install the vibration damper, washer and bolt. Lubricate and tighten the bolt to 108 N·m (80 ft. lbs.) torque.

(11) Install the A/C compressor (if equipped) and generator bracket assembly.

(12) Install the engine fan and hub assembly and shroud.

(13) Install the accessory drive belt and tighten to obtain the specified tension.

(14) Connect negative cable to battery.

TIMING CHAIN AND SPROCKETS

The chain drive system is equipped with a timing chain tensioner which reduces noise and prolongs timing chain life. In addition, it compensates for wear and temperature changes on the valve train for proper engine operation.

REMOVAL

- (1) Disconnect negative cable from battery.
- (2) Remove the fan and shroud.
- (3) Remove the serpentine drive belt.
- (4) Remove the crankshaft vibration damper.
- (5) Remove the timing case cover.
- (6) Rotate crankshaft until the "0" timing mark is closest to and on the center line with camshaft sprocket timing mark (Fig. 65).

(7) Remove the oil slinger from the crankshaft.

(8) Remove the camshaft retaining bolt and remove the sprockets and chain as an assembly (Fig. 66).

(9) To replace the timing chain tensioner, the oil pan must be removed.

INSTALLATION

(1) Turn the tensioner lever to the unlocked (down) position (Fig. 67).

(2) Pull the tensioner block toward the tensioner lever to compress the spring. Hold the block and turn the tensioner lever to the lock position (Fig. 67).

(3) Apply Mopar Silicone Rubber Adhesive Sealant to the keyway in the crankshaft and insert the key. With the key in the crankshaft keyway, install the

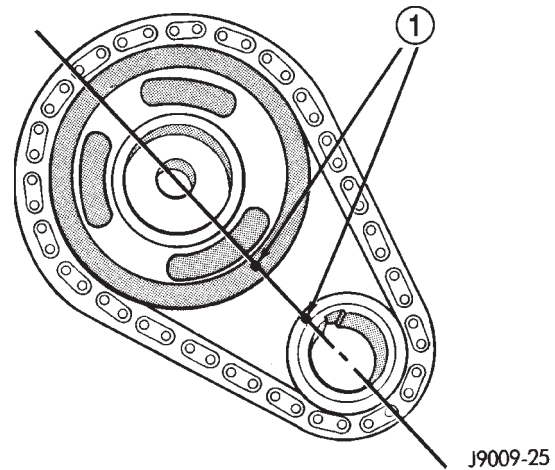

Fig. 65 Crankshaft—Camshaft Alignment

1 - TIMING MARKS

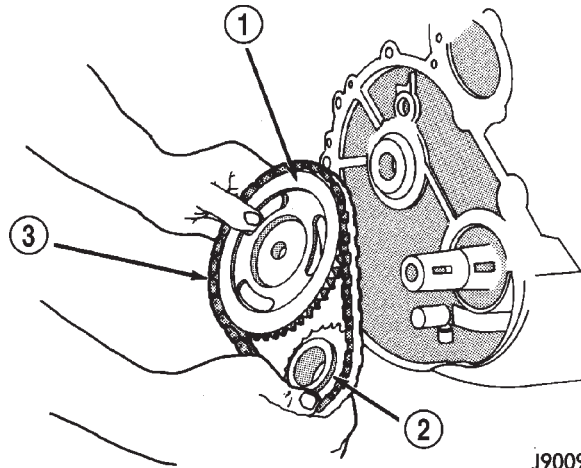

Fig. 66 Camshaft and Crankshaft Sprockets and Chain

1 - CAMSHAFT SPROCKET
2 - CRANKSHAFT SPROCKET
3 - CHAIN

crankshaft, camshaft sprockets and timing chain. Ensure the timing marks on the sprockets are properly aligned (Fig. 65).

(4) Install the camshaft sprocket retaining bolt and washer. Tighten the bolt to 108 N·m (80 ft. lbs.) torque.

(5) To verify correct installation of the timing chain, turn the crankshaft to position the camshaft sprocket timing mark as shown in (Fig. 68). Count the number of chain pins between the timing marks of both sprockets. There must be 20 pins.

(6) Turn the chain tensioner lever to the unlocked (down) position (Fig. 67).

(7) Install the oil slinger.

(8) Replace the oil seal in the timing case cover.

(9) Install the timing case cover and gasket.

REMOVAL AND INSTALLATION (Continued)

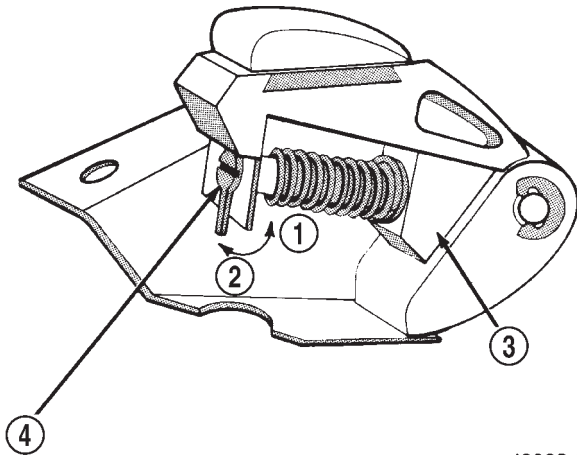

J9009-27

Fig. 67 Loading Timing Chain Tensioner

- 1 - LOCK
- 2 - UNLOCK
- 3 - TENSIONER BLOCK
- 4 - TENSIONER LEVER

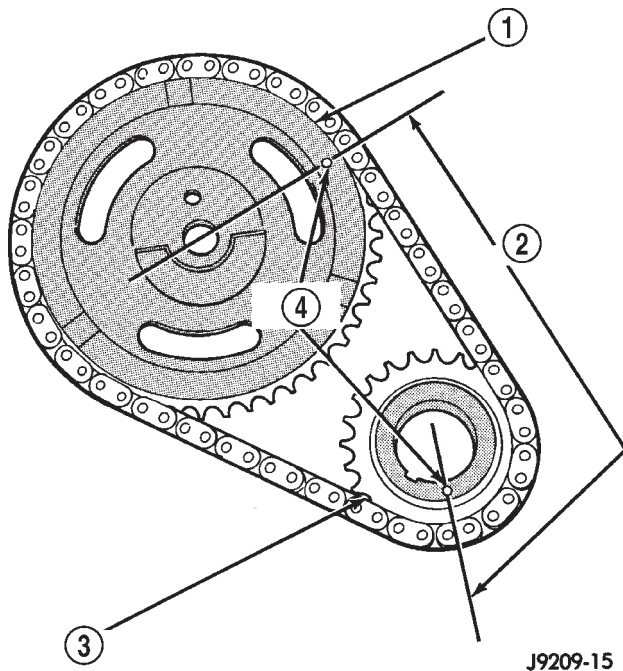

J9209-15

Fig. 68 Verify Sprocket—Chain Installation

- 1 - CAMSHAFT SPROCKET
- 2 - 20 PINS
- 3 - CRANKSHAFT SPROCKET
- 4 - TIMING MARKS

(10) With the key inserted in the keyway in the crankshaft, install the vibration damper, washer and bolt. Lubricate and tighten the bolt to 108 N·m (80 ft. lbs.) torque.

- (11) Install the fan and shroud.
- (12) Connect negative cable to battery.

CAMSHAFT

REMOVAL

WARNING: THE COOLANT IN A RECENTLY OPERATED ENGINE IS HOT AND PRESSURIZED. RELEASE THE PRESSURE BEFORE REMOVING THE DRAIN COCK, CAP AND DRAIN PLUGS.

- (1) Disconnect negative cable from battery.
- (2) Drain the cooling system. DO NOT waste reusable coolant. If the solution is clean, drain it into a clean container for reuse.
- (3) Remove the radiator or radiator and condenser, if equipped with A/C.
- (4) Scribe a mark on the distributor housing in line with the lip of the rotor.
- (5) Scribe a mark on the distributor housing near the clamp and continue the scribe mark on the cylinder block in line with the distributor mark.
- (6) For ease of installation, note the position of the rotor and distributor housing in relation to adjacent engine components.
- (7) Remove the distributor and ignition wires.
- (8) Remove the engine cylinder head cover.
- (9) Remove the rocker arms, bridges and pivots.
- (10) Remove the push rods.
- (11) Remove the hydraulic valve tappets from the engine cylinder head.
- (12) Remove the vibration damper.
- (13) Remove the timing case cover.
- (14) Remove the timing chain and sprockets.
- (15) Remove the camshaft (Fig. 69).

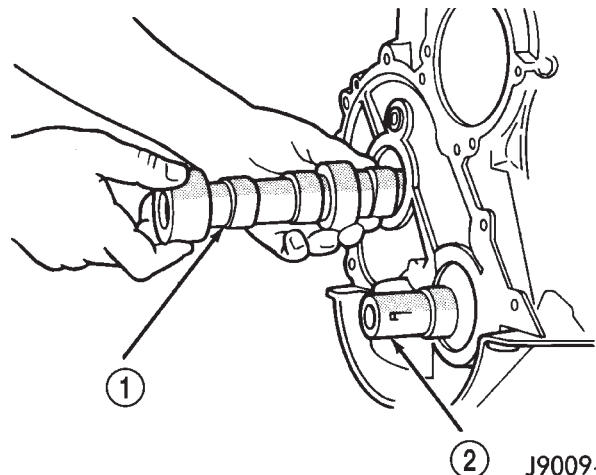

J9009-31

Fig. 69 Camshaft

- 1 - CAMSHAFT
- 2 - CRANKSHAFT

INSTALLATION

- (1) Inspect the cam lobes for wear.

REMOVAL AND INSTALLATION (Continued)

(2) Inspect the bearing journals for uneven wear pattern or finish.

(3) Inspect the bearings for wear.

(4) Inspect the distributor drive gear for wear.

(5) If the camshaft appears to have been rubbing against the timing case cover, examine the oil pressure relief holes in the rear cam journal. The oil pressure relief holes must be free of debris.

(6) Lubricate the camshaft with Mopar Engine Oil Supplement, or equivalent.

(7) Carefully install the camshaft to prevent damage to the camshaft bearings (Fig. 69).

(8) Turn the tensioner lever to the unlocked (down) position (Fig. 70).

(9) Pull the tensioner block toward the tensioner lever to compress the spring. Hold the block and turn the tensioner lever to the lock position (Fig. 70).

(10) Install the timing chain, crankshaft sprocket and camshaft sprocket with the timing marks aligned.

(11) Install the camshaft sprocket retaining bolt and washer. Tighten the bolt to 108 N·m (80 ft. lbs.) torque.

(12) Release the timing chain tensioner by moving the lever to the unlock position (Fig. 70).

(13) Install the timing case cover with a replacement oil seal (Fig. 71). Refer to Timing Case Cover Installation.

(14) Install the vibration damper.

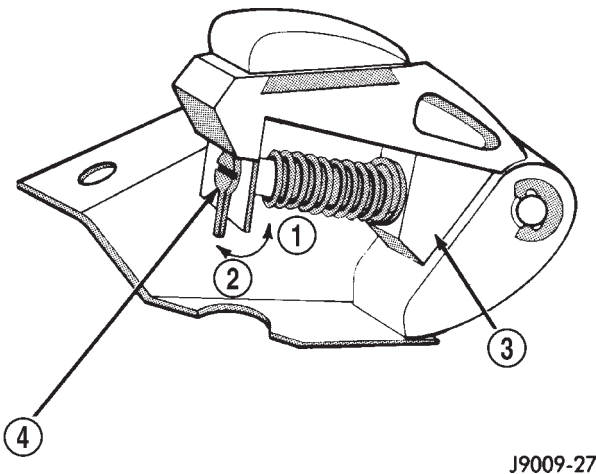

Fig. 70 Loading Timing Chain Tensioner

- 1 - LOCK
- 2 - UNLOCK
- 3 - TENSIONER BLOCK
- 4 - TENSIONER LEVER

(15) Install the hydraulic valve tappets.

(16) Install the push rods.

(17) Install the rocker arms, bridges and pivots.

(18) Install the engine cylinder head cover.

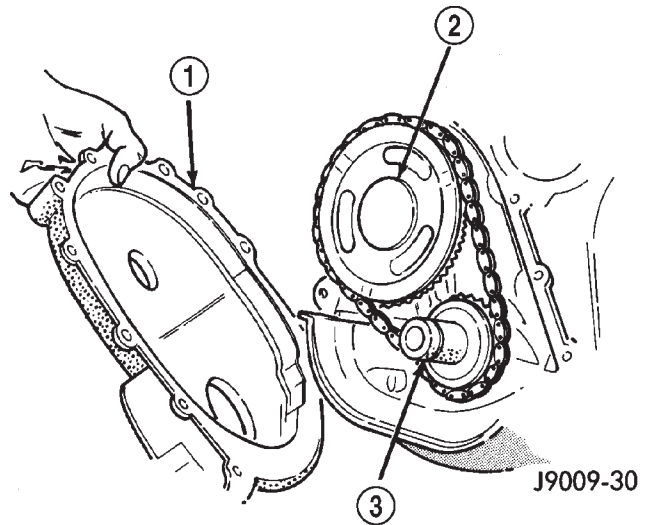

Fig. 71 Timing Case Cover

- 1 - TIMING CASE COVER
- 2 - CAMSHAFT
- 3 - CRANKSHAFT

(19) Position the oil pump gear. Refer to Distributor in the Component Removal/Installation section of Group 8D, Ignition Systems.

(20) Install the distributor and ignition wires. Refer to Distributor in the Component Removal/Installation section of Group 8D, Ignition Systems.

(21) Install the radiator or radiator and condenser, if equipped with A/C.

(22) Fill the cooling system.

(23) Connect negative cable to battery.

CAMSHAFT PIN REPLACEMENT

REMOVAL

WARNING: DO NOT LOOSEN THE RADIATOR DRAIN COCK WITH THE SYSTEM HOT AND PRESSURIZED BECAUSE SERIOUS BURNS FROM COOLANT CAN OCCUR.

- (1) Disconnect negative cable from battery.
- (2) Drain the radiator. DO NOT waste reusable coolant. Drain the coolant into a clean container.
- (3) Remove the fan and shroud.
- (4) Disconnect the radiator overflow tube, radiator hoses, automatic transmission fluid cooler pipes (if equipped).
- (5) Remove the radiator.
- (6) If equipped with air conditioning:

CAUTION: DO NOT loosen or disconnect any air conditioner system fittings. Move the condenser and receiver/drier aside as a complete assembly.

REMOVAL AND INSTALLATION (Continued)

- (a) Remove the A/C compressor serpentine drive belt idler pulley.
- (b) Disconnect and remove the generator.
- (c) Remove the A/C condenser attaching bolts and move the condenser and receiver/drier assembly up and out of the way.
- (7) Remove the serpentine drive belt.
- (8) Remove the crankshaft vibration damper.
- (9) Remove the timing case cover. Clean the gasket material from the cover.
- (10) Rotate crankshaft until the crankshaft sprocket timing mark is closest to and on the center line with the camshaft sprocket timing mark (Fig. 72).

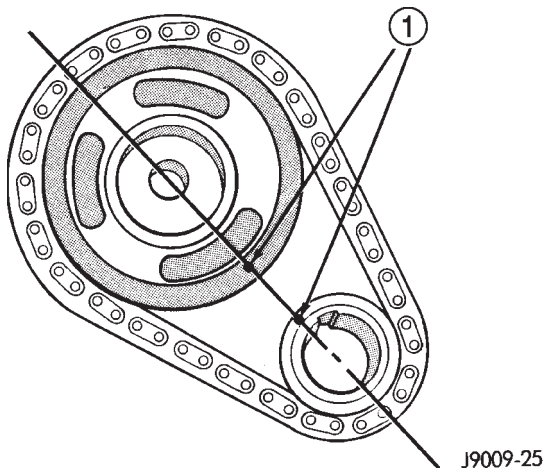
**Fig. 72 Timing Chain Alignment**

1 - TIMING MARKS

- (11) Remove camshaft sprocket retaining bolt.
- (12) Remove the crankshaft oil slinger.
- (13) Remove the sprockets and chain as an assembly (Fig. 73).

CAUTION: The following procedural step must be accomplished to prevent the camshaft from damaging the rear camshaft plug during pin installation.

- (14) Inspect the damaged camshaft pin.
- (15) If the pin is a spring-type pin, remove the broken pin by inserting a self-tapping screw into the pin and carefully pulling the pin from the camshaft.
- (16) If the pin is a dowel-type pin, center-punch it. Ensure the exact center is located when center-punching the pin.

CAUTION: Cover the opened oil pan area to prevent metal chips from entering the pan.

- (17) Drill into the pin center with a 4 mm (5/32 inch) drill bit.
- (18) Insert a self-tapping screw into the drilled pin and carefully pull the pin from the camshaft.

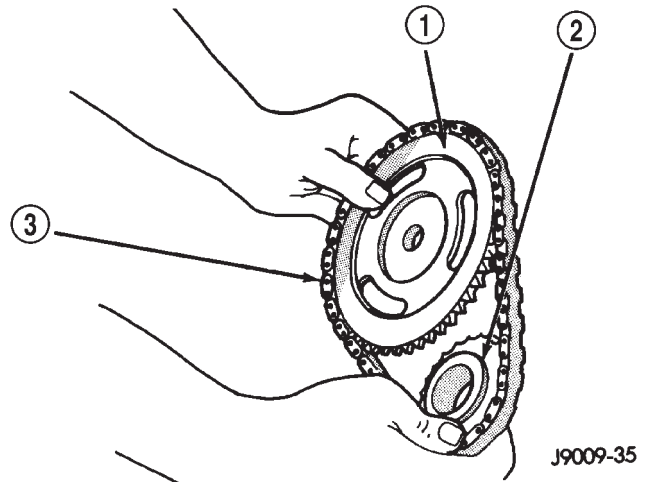
**Fig. 73 Camshaft and Crankshaft Sprocket and Chain**

- 1 - CAMSHAFT SPROCKET
- 2 - CRANKSHAFT SPROCKET
- 3 - CHAIN

INSTALLATION

- (1) Clean the camshaft pin hole.
- (2) Compress the center of the replacement spring pin with vise grips.
- (3) Carefully drive the pin into the camshaft pin hole until it is seated.
- (4) Install the camshaft sprocket, crankshaft sprocket and timing chain with the timing marks aligned (Fig. 72).
- (5) To verify correct installation of the timing chain, turn the crankshaft to position the camshaft sprocket timing mark as shown in (Fig. 74). Count the number of chain pins between the timing marks of both sprockets. There must be 20 pins.
- (6) Install the crankshaft oil slinger.
- (7) Tighten the camshaft sprocket bolt to 108 N·m (80 ft. lbs.) torque.
- (8) Check the valve timing.
- (9) Coat both sides of the replacement timing case cover gasket with gasket sealer. Apply a 3 mm (1/8 inch) bead of Mopar Silicone Rubber Adhesive Sealant, or equivalent to the joint formed at the timing case cover and cylinder block.
- (10) Position the timing case cover on the oil pan gasket and the cylinder block.
- (11) Place Timing Case Cover Alignment and Seal Installation Tool 6139 in the crankshaft opening of the cover (Fig. 75).
- (12) Install the timing case cover-to-cylinder block bolts. Install the oil pan-to-timing case cover bolts.
- (13) Tighten the 1/4 inch cover-to-block bolts to 7 N·m (60 in. lbs.) torque. Tighten the 5/16 inch front cover-to-block bolts to 22 N·m (192 in. lbs.) torque. Tighten the oil pan-to-cover 1/4 inch bolts to 14 N·m

REMOVAL AND INSTALLATION (Continued)

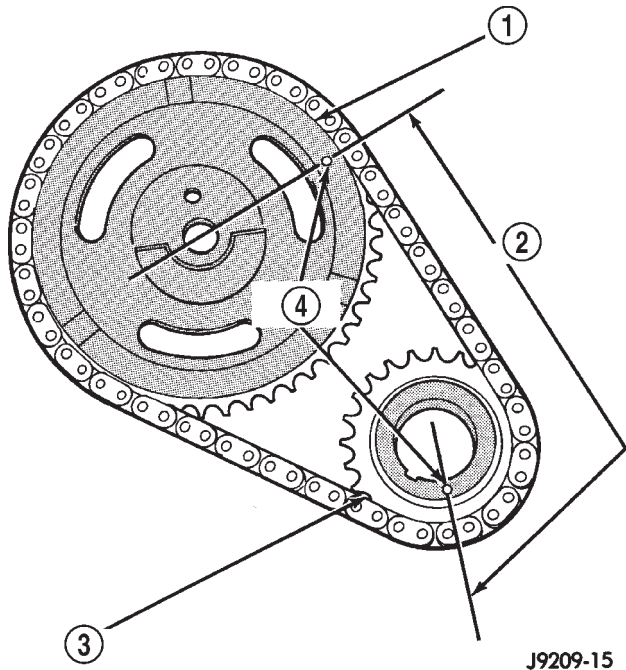

J9209-15

Fig. 74 Verify Crankshaft—Camshaft Installation

- 1 - CAMSHAFT SPROCKET
- 2 - 20 PINS
- 3 - CRANKSHAFT SPROCKET
- 4 - TIMING MARKS

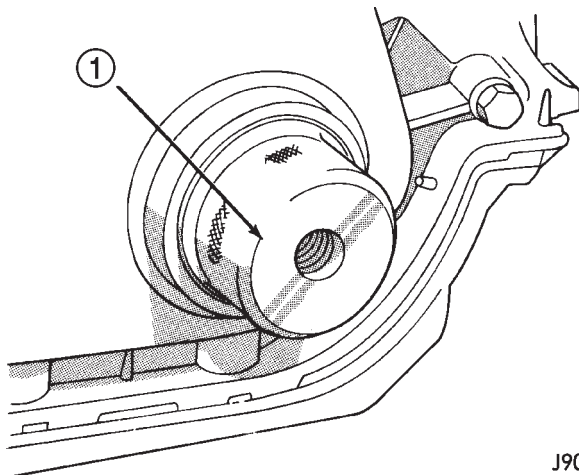

J9009-23

Fig. 75 Timing Case Cover Alignment and Seal Installation Tool 6139

- 1 - TIMING CASE COVER ALIGNMENT AND SEAL INSTALLATION TOOL

(120 in. lbs.) torque. Tighten the oil pan-to-cover 5/16 inch bolts to 18 N·m (156 in. lbs.) torque.

(14) Remove the cover alignment tool and install a replacement oil seal into the cover.

(15) Install the vibration damper on the crankshaft.

(16) Lubricate and tighten the damper bolt to 108 N·m (80 ft. lbs.) torque.

(17) If equipped with air conditioning:

(a) Install the A/C compressor serpentine drive belt idler pulley.

(b) Install the generator.

(c) Install the A/C condenser and receiver/drier assembly.

(18) Install the serpentine drive belt on the pulleys and tighten (refer to Group 7, Cooling System for the specifications and procedures).

(19) Install the radiator. Connect the radiator hoses and automatic transmission fluid cooler pipes, if equipped. Fill the cooling system.

(20) Install the fan and shroud.

(21) Connect negative cable to battery.

CAMSHAFT BEARINGS

The camshaft rotates within four steel-shelled, babbitt-lined bearings that are pressed into the cylinder block and then line reamed. The camshaft bearing bores and bearing diameters are not the same size. They are stepped down in 0.254 mm (0.010 inch) increments from the front bearing (largest) to the rear bearing (smallest). This permits easier removal and installation of the camshaft. The camshaft bearings are pressure lubricated.

NOTE: It is not advisable to attempt to replace camshaft bearings unless special removal and installation tools are available, such as recommended tool 8544 Camshaft Bushing Remover Installer.

Camshaft end play is maintained by the load placed on the camshaft by the oil pump and distributor drive gear. The helical cut of the gear holds the camshaft sprocket thrust face against the cylinder block face.

CRANKSHAFT MAIN BEARINGS**REMOVAL**

- (1) Disconnect negative cable from battery.
- (2) Remove the spark plugs.
- (3) Raise the vehicle.
- (4) Remove the oil pan and oil pump.
- (5) Remove only one main bearing cap and lower insert at a time (Fig. 76).

(6) Remove the lower insert from the bearing cap.

(7) Remove the upper insert by LOOSENING (DO NOT REMOVE) all of the other bearing caps. Now insert a small cotter pin tool in the crankshaft journal oil hole. Bend the cotter pin as illustrated to fabricate the tool (Fig. 77). With the cotter pin tool in place, rotate the crankshaft so that the upper bearing insert will rotate in the direction of its locking tab. Because there is no hole in the No.3 main journal, use a tongue depressor or similar soft-faced tool

REMOVAL AND INSTALLATION (Continued)

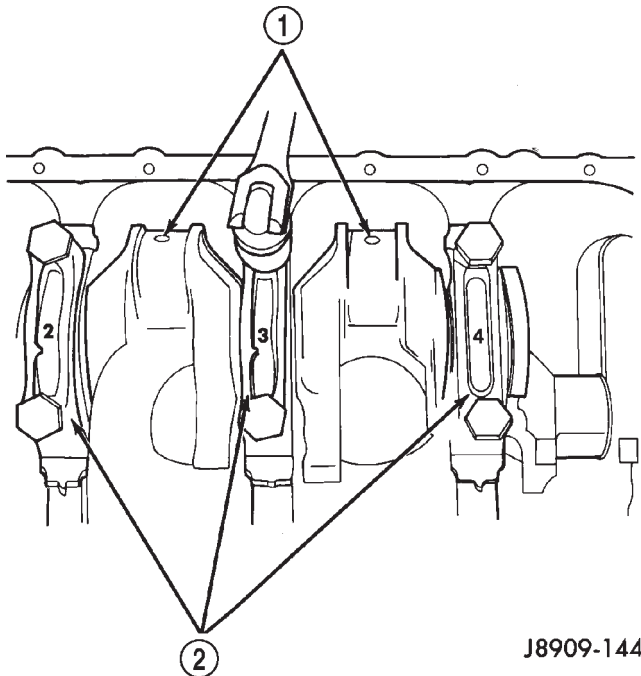

Fig. 76 Removing Main Bearing Caps and Lower Inserts

- 1 - CONNECTING ROD JOURNAL
- 2 - MAIN BEARING CAPS

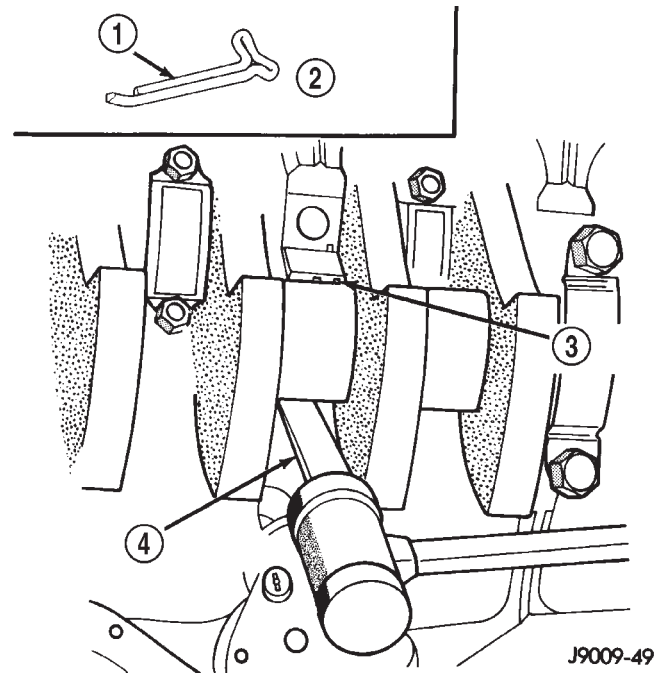

Fig. 77 Removing Upper Inserts

- 1 - COTTER PIN
- 2 - FABRICATED TOOL
- 3 - BEARING INSERT
- 4 - TONGUE DEPRESSOR

to remove the bearing insert (Fig. 77). After moving the insert approximately 25 mm (1 inch), it can be removed by applying pressure under the tab.

(8) Using the same procedure described above, remove the remaining bearing inserts one at a time for inspection.

INSTALLATION

(1) Lubricate the bearing surface of each insert with engine oil.

(2) Loosen all the main bearing caps. Install the main bearing upper inserts.

(3) Install the lower bearing inserts into the main bearing caps.

(4) Install the main bearing cap(s) and lower insert(s).

(5) Clean the rear main bearing cap (No.5) mating surfaces.

(6) Apply Mopar® Gasket Maker, or equivalent on the rear bearing cap (Fig. 78). The bead should be 3 mm (0.125 in) thick. DO NOT apply Mopar® Gasket Maker, or equivalent to the lip of the seal.

(7) Install the rear main bearing cap. DO NOT strike the cap more than twice for proper engagement.

(8) Tighten the bolts of caps 1, 3, 4 and 5 to 54 N·m (40 ft. lbs.) torque. Now tighten these bolts to 95 N·m (70 ft. lbs.) torque. Finally, tighten these bolts to 108 N·m (80 ft. lbs.) torque.

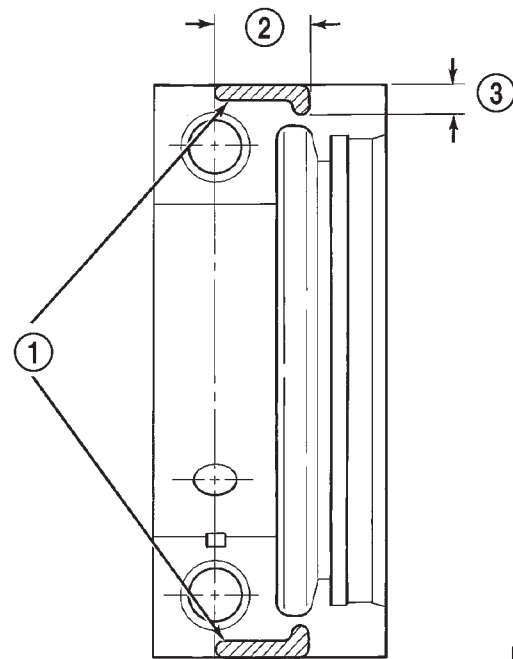

Fig. 78 Location of Mopar® Gasket Maker

- 1 - MOPAR® GASKET MAKER (OR EQUIVALENT)
- 2 - 19 mm (.75 IN)
- 3 - 6 mm (0.025 IN)

REMOVAL AND INSTALLATION (Continued)

(9) Push the crankshaft forward and backward. Load the crankshaft front or rear and tighten cap bolt No.2 to 54 N·m (40 ft. lbs.) torque. Then tighten to 95 N·m (70 ft. lbs.) torque and finally tighten to 108 N·m (80 ft. lbs.) torque.

(10) Rotate the crankshaft after tightening each main bearing cap to ensure the crankshaft rotates freely.

(11) Check crankshaft end play. Crankshaft end play is controlled by the thrust bearing which is flange and installed at the No.2 main bearing position.

(a) Attach a magnetic base dial indicator to the cylinder block at either the front or rear of the engine.

(b) Position the dial indicator rod so that it is parallel to the center line of the crankshaft.

(c) Pry the crankshaft forward, position the dial indicator to zero.

(d) Pry the crankshaft forward and backward. Note the dial indicator readings. End play is the difference between the high and low measurements (Fig. 79). Correct end play is 0.038-0.165 mm (0.0015-0.0065 inch). The desired specifications are 0.051-0.064 mm (0.002-0.0025 inch).

(e) If end play is not within specification, inspect crankshaft thrust faces for wear. If no wear is apparent, replace the thrust bearing and measure end play. If end play is still not within specification, replace the crankshaft.

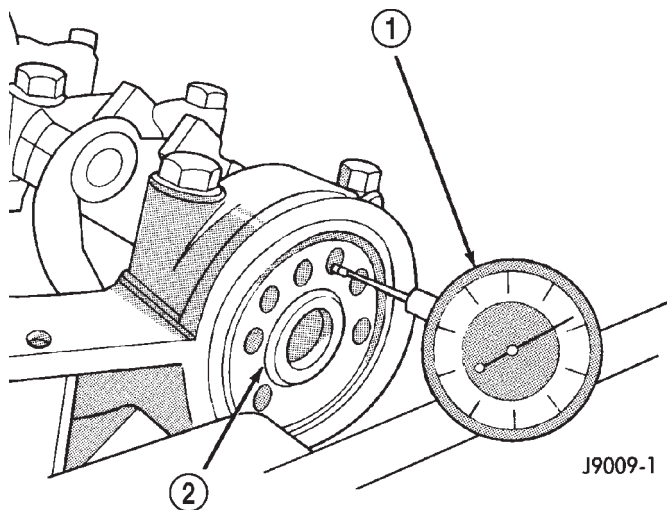

Fig. 79 Crankshaft End Play Measurement

- 1 - DIAL INDICATOR
2 - CRANKSHAFT

(12) If the crankshaft was removed, install the crankshaft into the cylinder block (refer to Cylinder Block - Assemble).

(13) Install the oil pan.

(14) Install the drain plug. Tighten the plug to 34 N·m (25 ft. lbs.) torque.

(15) Install new rear main seal. Refer to Rear Main Seal in this section.

(16) Lower the vehicle.

(17) Install the spark plugs. Tighten the plugs to 37 N·m (27 ft. lbs.) torque.

(18) Fill the oil pan with engine oil to the safe mark on the dipstick level.

(19) Connect negative cable to battery.

OIL PAN

REMOVAL

(1) Disconnect negative cable from battery.

(2) Raise the vehicle.

(3) Remove the oil pan drain plug and drain the engine oil.

(4) Disconnect the exhaust pipe at the engine exhaust manifold.

(5) Disconnect the exhaust hanger at the catalytic converter and lower the pipe.

(6) Remove the engine starter motor.

(7) Remove the flywheel/torque converter housing access cover.

(8) Position a jack stand directly under the engine vibration damper.

(9) Place a piece of wood (2 x 2) between the jack stand and the engine vibration damper.

(10) Remove the engine mount through bolts.

(11) Using the jack stand, raise the engine until adequate clearance is obtained to remove the oil pan.

(12) If equipped, disconnect the transmission cooler lines and oxygen sensor harness from oil pan mounting studs.

(13) Remove the oil pan bolts and studs. Carefully remove the oil pan and gasket.

INSTALLATION

(1) Clean the block and pan gasket surfaces.

(2) Fabricate 4 alignment dowels from 1/4 x 1 1/2 inch bolts. Cut the head off the bolts and cut a slot into the top of the dowel. This will allow easier installation and removal with a screwdriver (Fig. 80).

(3) Install two dowels in the timing case cover. Install the other two dowels in the cylinder block (Fig. 81).

(4) Apply Mopar® Silicone Adhesive Sealant onto the cylinder block in four location as shown (Fig. 82)

(5) Slide the one-piece gasket over the dowels and onto the block and timing case cover.

(6) Position the oil pan over the dowels and onto the gasket.

(7) Install the 1/4 inch oil pan bolts. Tighten these bolts to 9.5 N·m (84 in. lbs.) torque. Install the 5/16

REMOVAL AND INSTALLATION (Continued)

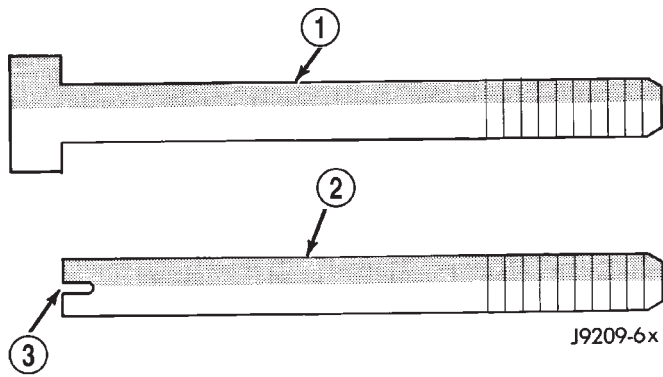
**Fig. 80 Fabrication of Alignment Dowels**

- 1 - 1/4" × 1 1/2" BOLT
- 2 - DOWEL
- 3 - SLOT

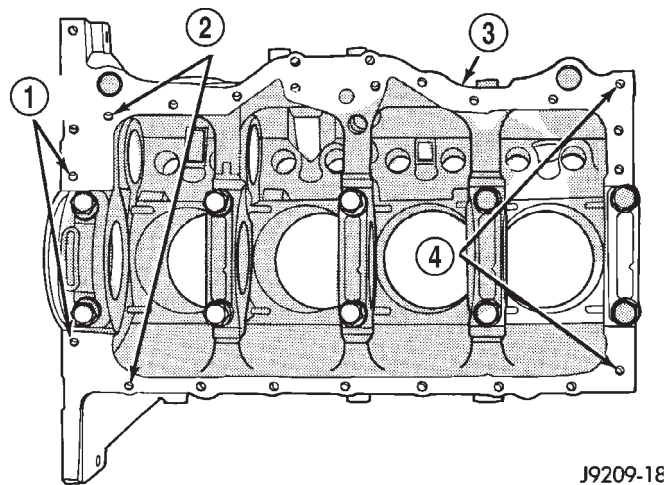
**Fig. 81 Position of Dowels in Cylinder Block**

- 1 - 5/16" HOLES
- 2 - DOWEL HOLES
- 3 - CYLINDER BLOCK
- 4 - 5/16" HOLES

inch oil pan bolts (Fig. 83). Tighten these bolts to 15 N·m (132 in. lbs.) torque.

(8) Remove the dowels. Install the remaining 1/4 inch oil pan bolts. Tighten these bolts to 9.5 N·m (84 in. lbs.) torque.

(9) Lower the engine until it is properly located on the engine mounts.

(10) Install the through bolts and tighten the nuts.

(11) Lower the jack stand and remove the piece of wood.

(12) Install the flywheel and torque converter housing access cover.

(13) Install the engine starter motor.

(14) Connect the exhaust pipe to the hanger and to the engine exhaust manifold.

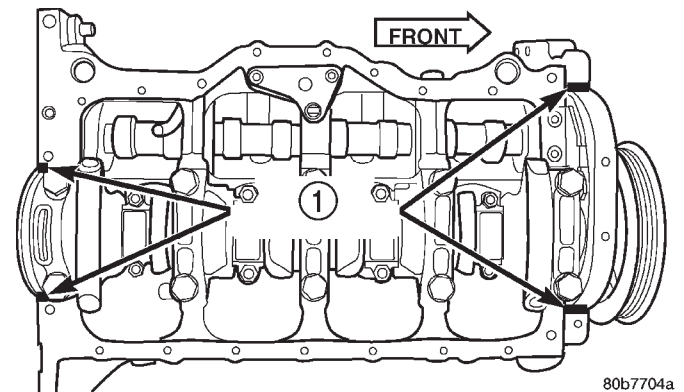
**Fig. 82 Location of Mopar® Silicone Adhesive Sealant on Cylinder Block**

- 1 - SEALER LOCATIONS

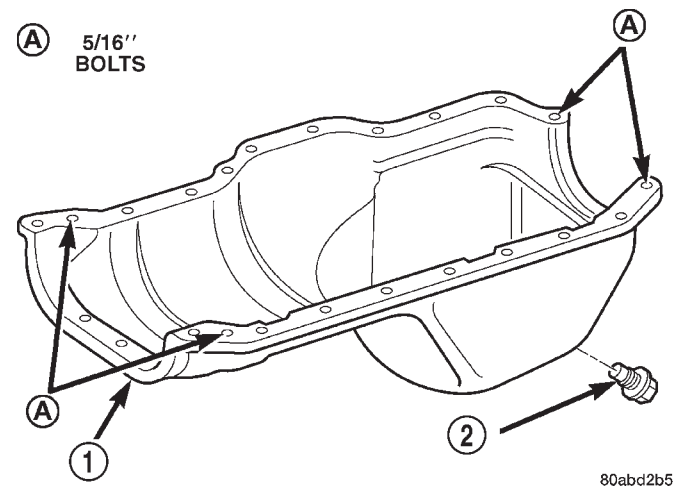
**Fig. 83 Position of 5/16 inch Oil Pan Bolts**

- 1 - OIL PAN
- 2 - OIL PAN DRAIN PLUG

(15) Install the oil pan drain plug (Fig. 83). Tighten the plug to 34 N·m (25 ft. lbs.) torque.

(16) Lower the vehicle.

(17) Connect negative cable to battery.

(18) Fill the oil pan with engine oil to the specified level.

WARNING: USE EXTREME CAUTION WHEN THE ENGINE IS OPERATING. DO NOT STAND IN A DIRECT LINE WITH THE FAN. DO NOT PUT YOUR HANDS NEAR THE PULLEYS, BELTS OR FAN. DO NOT WEAR LOOSE CLOTHING.

(19) Start the engine and inspect for leaks.

OIL PUMP

The positive-displacement gear-type oil pump is driven by the distributor shaft, which is driven by a gear on the camshaft. Oil is siphoned into the pump

REMOVAL AND INSTALLATION (Continued)

through an inlet tube and strainer assembly that is pressed into the pump body.

The pump incorporates a nonadjustable pressure relief valve to limit maximum pressure to 517 kPa (75 psi). In the relief position, the valve permits oil to bypass through a passage in the pump body to the inlet side of the pump.

Oil pump removal or replacement will not affect the distributor timing because the distributor drive gear remains in mesh with the camshaft gear.

REMOVAL

- (1) Drain the engine oil.
- (2) Remove the oil pan.
- (3) Remove the pump-to-cylinder block attaching bolts. Remove the pump assembly with gasket (Fig. 84).

CAUTION: If the oil pump is not to be serviced, **DO NOT** disturb position of oil inlet tube and strainer assembly in pump body. If the tube is moved within the pump body, a replacement tube and strainer assembly must be installed to assure an airtight seal.

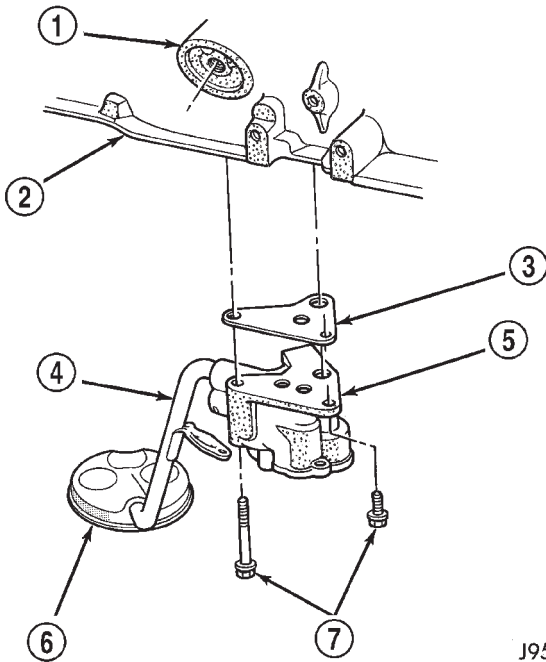

J9509-85

Fig. 84 Oil Pump Assembly

- 1 - OIL FILTER ADAPTOR
- 2 - BLOCK
- 3 - GASKET
- 4 - OIL INLET TUBE
- 5 - OIL PUMP
- 6 - STRAINER ASSEMBLY
- 7 - ATTACHING BOLTS

INSTALLATION

- (1) Install the oil pump on the cylinder block using a replacement gasket. Tighten the bolts to 23 N·m (17 ft. lbs.) torque.
- (2) Install the oil pan and gasket.
- (3) Fill the oil pan with oil to the specified level.

PISTON AND CONNECTING ROD

REMOVAL

- (1) Remove the engine cylinder head cover.
- (2) Remove the rocker arms, bridges and pivots.
- (3) Remove the push rods.
- (4) Remove the engine cylinder head.
- (5) Position the pistons one at a time near the bottom of the stroke. Use a ridge reamer to remove the ridge from the top end of the cylinder walls. Use a protective cloth to collect the cuttings.
- (6) Raise the vehicle.
- (7) Drain the engine oil.
- (8) Remove the oil pan and gasket.
- (9) Remove the connecting rod bearing caps and inserts. Mark the caps and rods with the cylinder bore location. The connecting rods and caps are stamped with a two letter combination (Fig. 85).

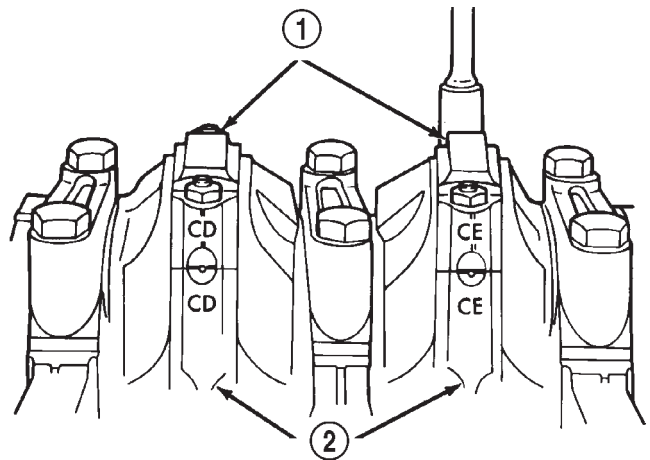

J9409-20

Fig. 85 Stamped Connecting Rods and Caps

- 1 - CONNECTING ROD CAP
- 2 - CONNECTING ROD

- (10) Lower the vehicle until it is about 2 feet from the floor.

CAUTION: Ensure that the connecting rod bolts **DO NOT** scratch the crankshaft journals or cylinder walls. Short pieces of rubber hose, slipped over the rod bolts will provide protection during removal.

- (11) Have an assistant push the piston and connecting rod assemblies up and through the top of the cylinder bores (Fig. 86).

REMOVAL AND INSTALLATION (Continued)

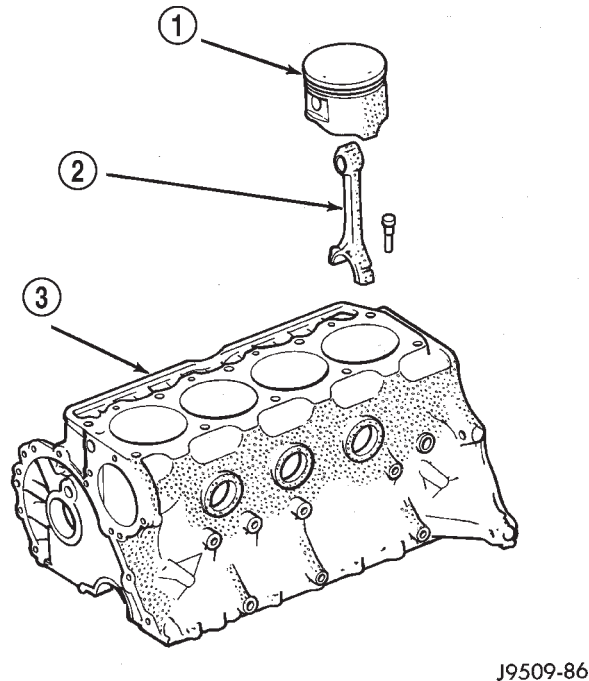

Fig. 86 Removal of Connecting Rod and Piston Assembly

- 1 - PISTON
2 - CONNECTING ROD
3 - CYLINDER BLOCK

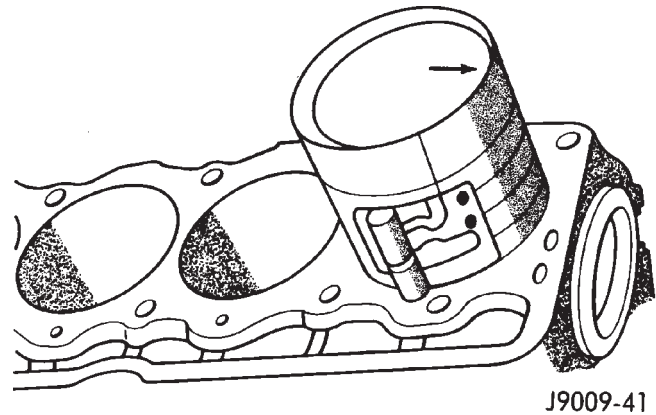

Fig. 87 Rod and Piston Assembly Installation

the bearing insert. The size is not stamped on inserts used for production of engines.

(9) The rod journal is identified during the engine production by a color-coded paint mark on the adjacent cheek or counterweight toward the flange (rear) end of the crankshaft. The color codes used to indicate journal sizes are listed in the Connecting Rod Bearing Fitting Chart.

(10) When required, upper and lower bearing inserts of different sizes may be used as a pair (refer to Connecting Rod Bearing Fitting Chart). A standard size insert is sometimes used in combination with a 0.025 mm (0.001 inch) undersize insert to reduce clearance 0.013 mm (0.0005 inch).

CAUTION: DO NOT intermix bearing caps. Each connecting rod and bearing cap are stamped with the cylinder number. The stamp is located on a machined surface adjacent to the oil squirt hole that faces the camshaft side of the cylinder block.

(11) Install the connecting rod bearing caps and inserts in the same positions as removed.

CAUTION: Verify that the oil squirt holes in the rods face the camshaft and that the arrows on the pistons face the front of the engine.

(13) Install the oil pan and gaskets as outlined in the installation procedure.

(14) Lower the vehicle.

(15) Install the engine cylinder head, push rods, rocker arms, bridges, pivots and engine cylinder head cover.

(16) Fill the crankcase with engine oil.

REAR MAIN OIL SEAL

REMOVAL

(1) Remove the flywheel or converter drive plate. Discard the old bolts.

INSTALLATION

(1) Clean the cylinder bores thoroughly. Apply a light film of clean engine oil to the bores with a clean lint-free cloth.

(2) Install the piston rings on the pistons if removed.

(3) Lubricate the piston and rings with clean engine oil.

CAUTION: Ensure that connecting rod bolts do not scratch the crankshaft journals or cylinder walls. Short pieces of rubber hose slipped over the connecting rod bolts will provide protection during installation.

(5) Use a piston ring compressor to install the connecting rod and piston assemblies through the top of the cylinder bores (Fig. 87).

(6) Ensure the arrow on the piston top points to the front of the engine (Fig. 87).

(7) Raise the vehicle.

(8) Each bearing insert is fitted to its respective journal to obtain the specified clearance between the bearing and the journal. In production, the select fit is obtained by using various-sized, color-coded bearing inserts as listed in the Connecting Rod Bearing Fitting Chart. The color code appears on the edge of

REMOVAL AND INSTALLATION (Continued)

(2) Pry out the seal from around the crankshaft flange, making sure not to scratch or nick the crankshaft. (Fig. 88).

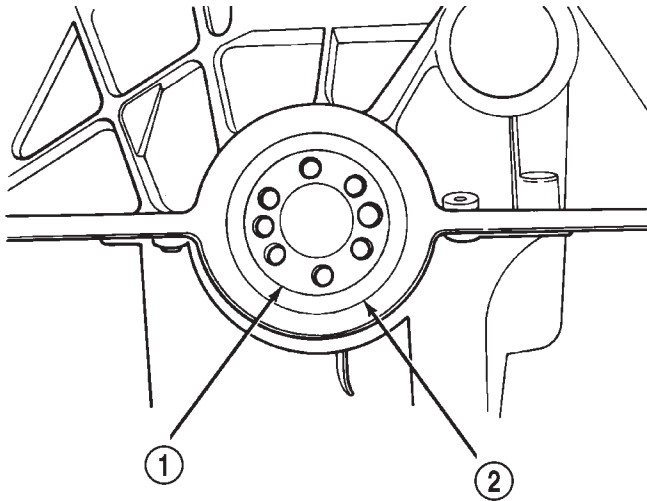

J8909-149

Fig. 88 Replacement of Rear Crankshaft Oil Seal

- 1 - CRANKSHAFT
2 - CRANKSHAFT OIL SEAL

INSTALLATION

(1) Wipe the seal surface area of the crankshaft until it is clean.

(2) Coat the outer lip of the replacement rear main bearing seal with engine oil.

(3) Carefully position the seal into place. Use rear main Seal Installer Tool 6271A to install the seal flush with the cylinder block.

CAUTION: The felt lip must be located inside the flywheel mounting surface. If the lip is not positioned correctly the flywheel could tear the seal.

(4) Install the flywheel or converter drive plate. New bolts **MUST** be used when installing the flywheel or converter plate. Tighten the new bolts to 68 N·m (50 ft. lbs.) torque. Turn the bolts an additional 60°.

DISASSEMBLY AND ASSEMBLY**CYLINDER BLOCK****DISASSEMBLY**

(1) Drain the engine oil. Remove and discard the oil filter.

(2) Remove the water pump from the cylinder block.

(3) Remove the distributor from the cylinder block.

(4) Remove the vibration damper.

(5) Remove the timing case cover and lay the cover upside down.

(6) Position a drift punch into the slot in the back of the cover and tap the old seal out.

(7) Remove the timing chain bumper.

(8) Remove the oil slinger from crankshaft.

(9) Remove the camshaft retaining bolt and remove the sprockets and chain as an assembly.

(10) Remove the camshaft.

(11) Remove the oil pan and gasket.

(12) Remove the timing chain tensioner.

(13) Remove the front and rear oil galley plugs.

(14) Remove the connecting rods and the pistons.

Remove the connecting rod and piston assemblies through the top of the cylinder bores.

(15) Remove the crankshaft.

ASSEMBLY

(1) Install the crankshaft.

(2) Install the connecting rods and the pistons through the top of the cylinder bores.

(3) Install the front and rear oil galley plugs.

(4) Install the timing chain tensioner.

(5) Install the camshaft.

(6) Install the sprockets and chain as an assembly.

(7) Install the oil slinger to the crankshaft.

(8) Install the timing chain bumper.

(9) Install the timing case cover seal.

(10) Install the timing case cover.

(11) Install the oil pan gasket and oil pan.

(12) Install the vibration damper.

(13) Install the water pump. Tighten the mounting bolts to 31 N·m (270 in. lbs.) torque.

(14) Remove the distributor from the cylinder block.

(15) Lubricate the oil filter seal with clean engine oil. Tighten oil filter to 18 N·m (13 ft. lbs.) torque.

(16) Install the engine into the vehicle.

(17) Fill the engine with clean lubrication oil.

(18) Fill the cooling system.

CLEANING AND INSPECTION**ROCKER ARMS AND PUSH RODS****CLEANING**

Clean all the components with cleaning solvent.

Use compressed air to blow out the oil passages in the rocker arms and push rods.

INSPECTION

Inspect the pivot surface area of each rocker arm. Replace any that are scuffed, pitted, cracked or excessively worn.

CLEANING AND INSPECTION (Continued)

Inspect the valve stem tip contact surface of each rocker arm and replace any rocker arm that is deeply pitted.

Inspect each push rod end for excessive wear and replace as required. If any push rod is excessively worn because of lack of oil, replace it and inspect the corresponding hydraulic tappet for excessive wear.

Inspect the push rods for straightness by rolling them on a flat surface or by shining a light between the push rod and the flat surface.

A wear pattern along the length of the push rod is not normal. Inspect the engine cylinder head for obstruction if this condition exists.

ENGINE CYLINDER HEAD

CLEANING

Thoroughly clean the engine cylinder head and cylinder block mating surfaces. Clean the intake and exhaust manifold and engine cylinder head mating surfaces. Remove all gasket material and carbon.

Check to ensure that no coolant or foreign material has fallen into the tappet bore area.

Remove the carbon deposits from the combustion chambers and top of the pistons.

INSPECTION

Use a straightedge and feeler gauge to check the flatness of the engine cylinder head and block mating surfaces.

CYLINDER BLOCK

CLEANING

Thoroughly clean the oil pan and engine block gasket surfaces.

Use compressed air to clean out:

- The galley at the oil filter adaptor hole, the filter bypass hole (Fig. 89).
- The front and rear oil galley holes (Fig. 90) (Fig. 91).
- The feed holes for the crankshaft main bearings.

Once the block has been completely cleaned, apply Mopar® Thread Sealant with Teflon to the threads of the front and rear oil galley plugs. Tighten the plugs to 41 N·m (30 ft. lbs.) torque.

INSPECTION

Inspect the cylinder bores for signs of scarring, pitting or cracks. If the cylinder bores are scorred or pitted the cylinder bores will require boring or honing to clean them up. Refer to Honing Cylinder Bores in this Section. If the cylinder bore(s) are cracked the cylinder block must be replaced.

Inspect the cylinder block to cylinder head mating surface for flatness and/or pitting.

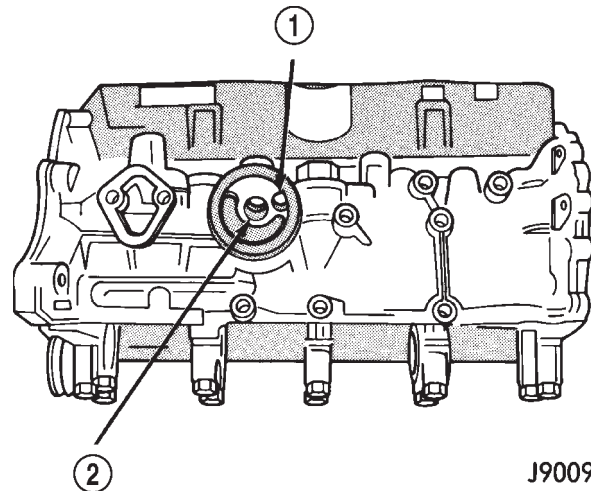

J9009-50

Fig. 89 Oil Filter Adaptor Hole

- 1 - FILTER BYPASS HOLE
2 - OIL FILTER ADAPTOR HOLE

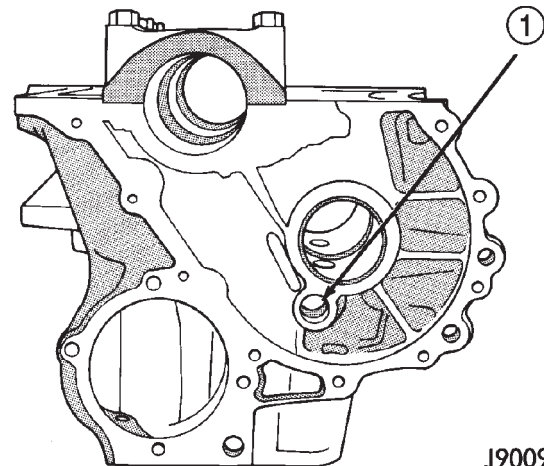

J9009-51

Fig. 90 Front Oil Galley Hole

- 1 - FRONT OIL GALLEY HOLE

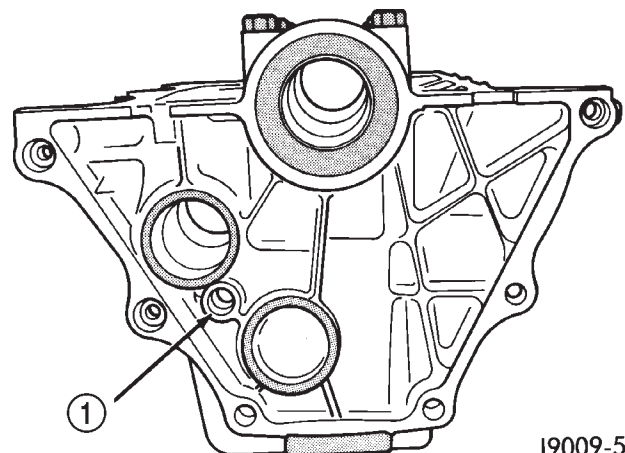

J9009-52

Fig. 91 Rear Oil Galley Hole

- 1 - REAR OIL GALLEY HOLE

SPECIFICATIONS

ENGINE SPECIFICATIONS

ENGINE DESCRIPTION

DESCRIPTION	SPECIFICATION
Engine Type	In-line 4 Cylinder
Bore and Stroke	98.4 x 81.0 mm (3.88 x 3.19 in.)
Displacement	2.5L (150 cu. in.)
Compression Ratio	9.1:1
Compression Pressure Range	827 to 1,034 kPa (120 to 150 psi)
Max. Variation Between Cylinders	206 kPa (30 psi)
Firing Order	1-3-4-2
Lubrication	Pressure Feed-Full Flow Filtration
Cooling System	Liquid Cooled-Forced Circulation
Cylinder Block	Cast Iron
Crankshaft	Cast Nodular Iron
Cylinder Head	Cast Iron
Camshaft	Cast Iron
Pistons	Aluminum Alloy
Cylinder Combustion Cavity	Double Quench
Connecting Rods	Cast Iron
CAMSHAFT	
Hydraulic Tappet Clearance	Zero Lash
Bearing Clearance	0.025 - 0.076 mm (0.001 - 0.003 in.)

DESCRIPTION	SPECIFICATION
Bearing Journal Diameter	
No. 1	51.54 - 51.56 mm (2.029 - 2.030 in.)
No. 2	51.28 - 51.31 mm (2.019 - 2.020 in.)
No. 3	51.03 - 51.05 mm (2.009 - 2.010 in.)
No. 4	50.78 - 50.80 mm (1.999 - 2.000 in.)
Base Circle Runout (Max)	0.03 mm (0.001 in.)
Camshaft Lobe Lift	
Exhaust	6.579 mm (0.259 in.)
Intake	6.477 mm (0.255 in.)
Camshaft Duration	
Intake	253.3°
Exhaust	259°
VALVES	
Valve Lift	
Exhaust	10.528 mm (0.4145 in.)
Intake	10.350 mm (0.4075 in.)
Intake Valve Timing	
Opens	15.4° (BTDC)
Closes	58° (ABDC)
Duration	253.3°
Exhaust Valve Timing	
Opens	52.8° (BBDC)
Closes	26.2° (ATDC)
Duration	259°
Valve Overlap	41.6°
Valve Length (Overall)	
Intake	124.435 - 125.070 mm (4.899 - 4.924 in.)
Exhaust	125.120 - 125.755 mm (4.927 - 4.952 in.)
Valve Stem Diameter	7.899 - 7.925 mm (0.311 - 0.312 in.)

SPECIFICATIONS (Continued)

DESCRIPTION	SPECIFICATION
Stem to Guide Clearance	0.025 - 0.076 mm (0.001 - 0.003 in.)
ValveFace Angle	
Intake	46.5°
Exhaust	46.5°
Valve Head Diameter	
Intake	48.387 - 48.641 mm (1.905 - 1.915 in.)
Exhaust	37.973 - 38.227 mm (1.495 - 1.505 in.)
Tip Refinishing (Max Allowable)	0.25 mm (0.010 in.)
VALVE SPRINGS	
Free Length (Approx.)	47.65 mm (1.876 in.)
Spring Load	
Valve Closed	316 to 351 N @ 41.656 mm (71 to 79 Lbs. @ 1.64 in.)
Valve Open	898.6 to 969.7 N @ 30.89 mm (202 to 218 Lbs. @ 1.216 in.)
Inside Diameter (Top)	21.0 mm to 21.51 mm (0.827 to 0.847 in.)
Installed Height	41.656 mm (1.640 in.)
CRANKSHAFT	
End Play	0.038 to 0.165 mm (0.0015 to 0.0065 in.)
Main Bearing Journal Diameter	63.489 to 63.502 mm (2.4996 to 2.5001 in.)

DESCRIPTION	SPECIFICATION
Main Bearing Journal Width	
No. 1	27.58 to 27.89 mm (1.086 to 1.098 in.)
No. 2	32.28 to 32.33 mm (1.271 to 1.273 in.)
No. 3-4-5	30.02 to 30.18 mm (1.182 to 1.188 in.)
Main Bearing Clearance	0.03 to 0.06 mm (0.001 to 0.0025 in.)
Main Bearing Clearance (Preferred)	0.051 mm (0.002 in.)
Connecting Rod Journal Diameter	53.17 to 53.23 mm (2.0934 to 2.0955 in.)
Connecting Rod Journal Width	27.18 to 27.33 mm (1.070 to 1.076 in.)
Out of Round - Max	0.013 mm (0.0005 in.)
Taper - Max	0.013 mm (0.0005 in.)
CYLINDER BLOCK	
Deck Height	236.73 mm (9.320 in.)
Deck Clearance	0.000 mm (0.000 in.)
Cylinder Bore Diameter—Standard	98.45 to 98.48 mm (3.8759 to 3.8775 in.)
Cylinder Bore Diameter—Taper (Max)	0.025 mm (0.001 in.)
Out of Round (Max)	0.025 mm (0.001 in.)
Tappet Bore Diameter	23.000 to 23.025 mm (0.9055 to 0.9065 in.)
Flatness	0.03 mm per 25 mm (0.001 in. per 1 in.) 0.05 mm per 152 mm (0.002 in. per 6 in.)

SPECIFICATIONS (Continued)

DESCRIPTION	SPECIFICATION
Flatness Max	0.20 mm for total length (0.008 in. for total length)
Main Bearing Bore Diameter	68.3514 to 68.3768 mm (2.691 to 2.692 in.)
CONNECTING RODS	
Total Weight (Less Bearing)	663 to 671 grams (23.39 to 23.67 oz.)
Length (Center to Center)	155.52 to 155.62 mm (6.123 to 6.127 in.)
Piston Pin Bore Diameter	23.59 to 23.62 mm (0.9288 to 0.9298 in.)
Bore (Less Bearings)	56.08 to 56.09 mm (2.2080 to 2.2085 in.)
Bearing Clearance	0.025 to 0.076 mm (0.001 to 0.003 in.)
Bearing Clearance (Preferred)	0.044 to 0.050 mm (0.0015 to 0.0020 in.)
Side Clearance	0.25 to 0.48 mm (0.010 to 0.019 in.)
Twist (Max)	0.002 mm per mm (0.002 in. per in.)
Bend (Max)	0.006 mm per mm (0.006 in. per inch.)
CYLINDER HEAD	
Combustion Chamber	49.9 to 52.9 cc (3.04 to 3.23 cu. in.)
Valve Guide I. D. (Integral)	7.95 to 7.97 mm (0.313 to 0.314 in.)
Valve Seat Angle Intake Exhaust	44.5° 44.5°
Valve Seat Width	1.01 to 1.52 mm (0.040 to 0.060 in.)

DESCRIPTION	SPECIFICATION
Valve Seat Runout	0.064 mm (0.0025 in.)
Flatness	0.03 mm per 25 mm (0.001 in. per 1 in.) 0.05 mm per 152 mm (0.002 in. per 6 in.)
Flatness (Max)	0.20 mm for total length (0.008 in. for total length)
ROCKER ARMS, PUSH RODS & TAPPETS	
Rocker Arm Ratio	1.6:1
Push Rod Length (Blue)	241.300 to 241.808 mm (9.500 to 9.520 in.)
Push Rod Diameter	7.92 to 8.00 mm (0.312 to 0.315 in.)
Hydraulic Tappet Diameter	22.962 to 22.974 mm (0.904 to 0.9045 in.)
Tappet to Bore Clearance	0.025 to 0.063 mm (0.001 to 0.0025 in.)
PISTON	
Weight (Less Pin)	417 to 429 grams (14.7 to 15.1 oz.)
Compression Height	40.61 to 40.72 mm (1.599 to 1.603 in.)
Piston to Bore Clearance	0.018 to 0.038 mm (0.0008 to 0.0015 in.)
Piston Ring Groove Height Compression Rings Oil Control Ring	1.530 to 1.555 mm (0.0602 to 0.0612 in.) 4.035 to 4.060 mm (0.1589 to 0.1598 in.)
Piston Ring Groove Diameter Compression Ring #1 Compression Ring #2	88.39 to 88.65 mm (3.48 to 3.49 in.) 87.63 to 87.88 mm (89.66 to 89.92 in.)

SPECIFICATIONS (Continued)

DESCRIPTION	SPECIFICATION
Oil Control Ring	89.66 to 89.92 mm (3.53 to 3.54 in.)
Piston Pin Bore Diameter	23.650 to 23.658 mm (0.9312 to 0.9315 in.)
Piston Pin Diameter	23.637 to 23.640 mm (0.9306 to 0.9307 in.)
Piston to Pin Clearance	0.0102 to 0.0208 mm (0.0005 to 0.0009 in.)
PISTON RINGS	
Ring Gap Clearance Top Compression Ring	0.229 to 0.610 mm (0.0090 to 0.0240 in.)
2nd Compression Ring	0.483 to 0.965 mm (0.0190 to 0.0380 in.)
Oil Control Steel Rails	0.254 to 1.500 mm (0.010 to 0.060 in.)
Ring Side Clearance Compression Rings	0.042 to 0.084 mm (0.0017 to 0.0033 in.)
Oil Control Rings	0.06 to 0.21 mm (0.0024 to 0.0083 in.)

DESCRIPTION	SPECIFICATION
OIL PUMP AND OIL PRESSURE	
Gear to Body Clearance (Radial) (Radial Preferred)	0.051 to 0.102 mm (0.002 to 0.004 in.) 0.051 mm (0.002 in.)
Gear End Clearance— Plastigage Plastigage Preferred Feeler Gauge Feeler Gauge Preferred	0.051 to 0.152 mm (0.002 to 0.006 in.) 0.051 mm (0.002 in.) 0.1016 to 0.2032 mm (0.004 to 0.008 in.) 0.1778 mm (0.007 in.)
Min. Pressure (600 rpm)	89.6 kPa (13 psi)
Min. Pressure at Idle (800 rpm)	172 to 241 kPa (25 to 35 psi)
Min. Pressure at 1600 rpm and Higher	255 to 517 kPa (37 to 75 psi)
Oil Pressure Relief	517 kPa (75 psi)

SPECIFICATIONS (Continued)

SPECIFICATIONS—TORQUE

TORQUE CHART 2.5L ENGINE

DESCRIPTION	N-m	Ft. Lbs.	In. Lbs
A/C Compressor Bracket to Engine—Bolts	47	35	—
A/C Compressor Mounting Bolts	28	—	250
Block Heater Nut	1.8	—	16
Camshaft Sprocket Bolt	108	80	—
Clutch Cover to Flywheel Bolts	31	23	—
Connecting Rod Cap Nuts	45	33	—
Cylinder Block Drain Plugs	41	30	—
Cylinder Head Bolts #1–10 & #12–14	149	110	—
Cylinder Head Bolt #11	135	100	—
Cylinder Head Cover Bolts	13	—	115
Dipstick Tube Bracket to Cylinder Block—Bolt	19	—	168
Distributor Hold-Down Clamp Bolt	23	—	204
Engine Front Insulator Bracket—Bolts	81	60	—
Insulator Bracket—Nuts	47	35	—
Insulator—Through Bolt	81	60	—
Engine Rear Support Cushion /Crossmember—Nuts	22	—	192
Support Cushion/Bracket Nuts	46	34	—
Transmission Support Bracket—Bolts	43	32	—
Transmission Support Bracket /Cushion—Bolt	75	55	—
Transmission Support Adaptor Bracket—Bolts	75	55	—
Exhaust Manifold/Pipe Nuts	27	20	—

DESCRIPTION	N-m	Ft. Lbs.	In. Lbs
Exhaust Manifold Bolt #1	41	30	—
Bolts #2-5	31	23	—
Nuts 6 and 7	14	—	126
Flywheel/Converter Housing Bolts	38	28	—
Flywheel to Crankshaft Bolts	143	105	—
Front Cover to Block Bolts 1/4-20	7	—	60
Front Cover to Block 5/16-18	22	—	192
Generator Mounting—Bolts	57	42	—
Generator Mounting Bracket to Engine—Bolts	47	35	—
Main Bearing Cap Bolts	108	80	—
Oil Filter Adaptor Bolt	102	75	—
Oil Filter Connector	68	50	—
Oil Filter	18	13	—
Oil Galley Plug	41	30	—
Oil Pan 1/4-20 Bolts	9.5	—	84
Oil Pan 5/16-18 Bolts	15	—	132
Oil Pan Drain Plug	34	25	—
Oil Pressure Sending Unit	15	—	130
Oil Pump Short Attaching Bolts	23	—	204
Oil Pump Long Attaching Bolts	23	—	204
Oil Pump Cover Bolts	8	—	70
Rocker Arm—Bolts	28	21	—
Spark Plugs	37	27	—
Starter Motor Mounting Bolts	45	33	—
Thermostat Housing Bolts	18	—	156
Throttle Body Bolts	10	—	90
Vibration Damper Bolt	108	80	—
Water Pump to Block Bolts	31	23	—

SPECIAL TOOLS

2.5L ENGINE SPECIAL TOOLS

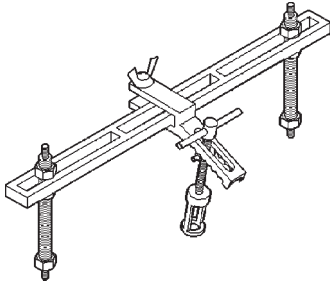

Valve Spring Compressor Tool MD-998772A

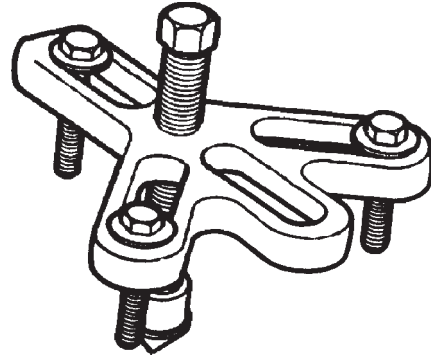

Vibration Damper Removal Tool 7697

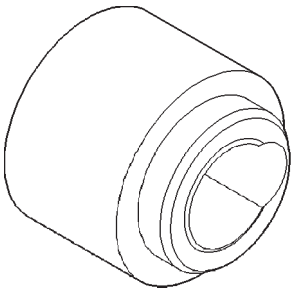

**Timing Case Cover Alignment and Seal installation
Tool 6139**

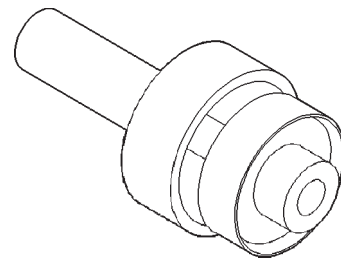

Rear Main Seal Installer Tool 6271A

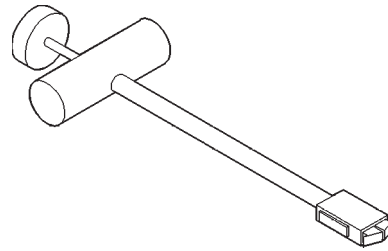

**Hydraulic Valve Tappet Removal/Installation Tool
C-4129-A**