

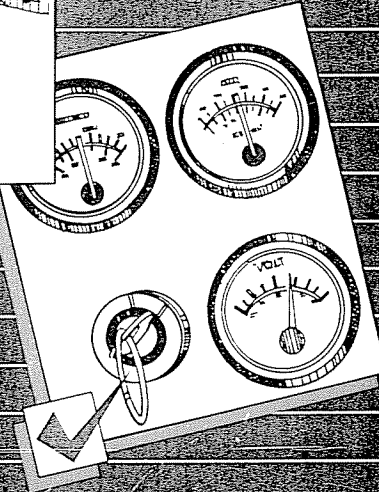

Operation and Maintenance Manual C Series Diesel Engines

Models: 6C8.3 6CT8.3 6CTA8.3

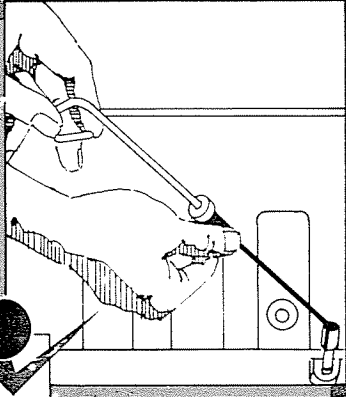
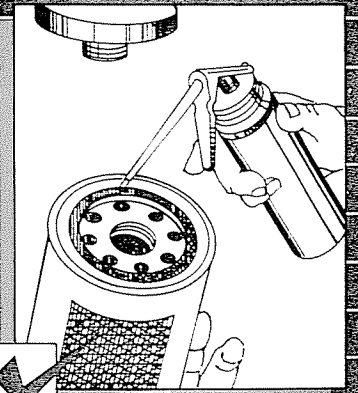
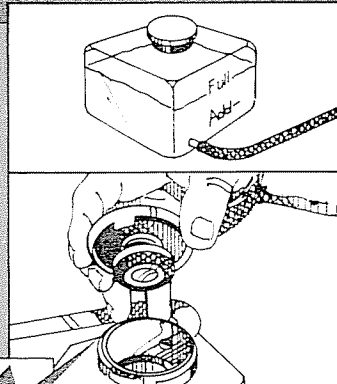

Operation and Maintenance Manual

Cummins Diesel Engines - C Series

Engine Models

6C8.3 6CT8.3 6CTA8.3

Important Reference Numbers

Fill in the part name and number in the blank spaces provided below. This will give you a reference whenever service or maintenance is required.

Engine Serial Number	_____	
Engine CPL Number	_____	
Fuel Pump Part Number	_____	
Engine Model	_____	
Filter Part Numbers	_____	_____
	_____	_____
	_____	_____
	_____	_____
Belt Part Numbers	_____	_____
	_____	_____
	_____	_____
	_____	_____
	_____	_____

Table of Contents

	Page No.
Warranty.....	i-7
Introduction.....	0-1
Operating Instructions.....	1-1
Maintenance Guidelines.....	2-1
Troubleshooting.....	3-1
Adjustment and Replacement.....	4-1
Engine Specifications.....	5-1
Service Assistance.....	6-1
Component Manufacturers.....	7-1
Service Literature.....	8-1
Index.....	9-1

Cummins Warranty - Automotive

COVERAGE

This warranty applies to C Series Engines (including fuel pumps, starters, alternators, air compressors and power steering pumps) sold by Cummins that are used in automotive on-highway applications in the United States* or Canada with one exception. Cummins provides different warranty coverage for Engines used in fire truck applications. This warranty applies to Engines delivered to the first user on or after January 1, 1988.

This warranty covers any failures of the Engine which result, under normal use and service, from defects in material or workmanship (Warrantable Failures). This coverage begins on the date of delivery of the Engine to the first user and continues for the Duration** stated below:

<u>Engine Horsepower</u>	<u>Duration**</u> <u>(whichever occurs first)</u>	
	<u>Months</u>	<u>Miles (Kilometers)</u>
Up to 225	24	Unlimited
226 and over	24	100,000 (160,935)

** Duration on starters, alternators and non-Cummins air compressors and power steering pumps is 6 months or 50,000 miles (80,468 kilometers), whichever occurs first.

Additional coverage is outlined in the Emission Warranty on the back page.

This warranty continues to all subsequent Owners until the end of the Duration stated above.

CUMMINS RESPONSIBILITIES

Cummins will pay for all parts and labor needed to repair the damage to the Engine resulting from the Warrantable Failure. All labor costs will be paid in accordance with Cummins' published Standard Repair Time guidelines.

Cummins will pay for the lubricating oil, antifreeze, filter elements and other maintenance items that are not reusable due to the Warrantable Failure.

Cummins will pay reasonable labor costs for Engine removal and reinstallation when necessary to make the warranty repair.

OWNER RESPONSIBILITIES

Owner is responsible for the operation and maintenance of the Engine as specified in Cummins Operation and Maintenance Manuals.

Before the expiration of the applicable warranty, Owner must notify a Cummins distributor, authorized dealer or other repair location approved by Cummins of any Warrantable Failure and deliver the Engine to such facility for repair. Locations in the United States and Canada are listed in the Cummins United States and Canada Sales and Service Directory; other locations are listed in the Cummins International Sales and Service Directory.

Owner is responsible for the cost of lubricating oil, antifreeze, filter elements and other maintenance items replaced during warranty repairs unless such items are not reusable due to the Warrantable Failure.

Owner is responsible for communication expenses, meals, lodging and similar costs incurred by Owner as a result of a Warrantable Failure.

Owner is responsible for non-Engine repairs and for "downtime" expenses, cargo damage, and all business costs and losses resulting from a Warrantable Failure. **CUMMINS IS NOT RESPONSIBLE FOR INCIDENTAL OR CONSEQUENTIAL DAMAGES.**

LIMITATIONS

Cummins is not responsible for failures resulting from Owner or operator abuse or neglect such as: operation without adequate coolant or lubricants; overfueling; overspeeding; lack of maintenance of lubricating, cooling or air intake systems; improper storage, starting, warm-up, run-in or shutdown practices. Cummins is also not responsible for failures caused by incorrect fuel or by water, dirt or other contaminants in the fuel.

Except for the five components included with the Engine in the first paragraph under "COVERAGE," this warranty does not apply to accessories supplied by Cummins which bear the name of another company. This

category includes, but is not limited to, fans, air conditioning compressors, clutches, filters, transmissions, torque converters, and non-Cummins engine compression brakes.

This warranty and the Emission Warranty are void and nonbinding on Cummins if, at the time of failure, the Engine is determined to have been modified so as to substantially alter its operating characteristics.

Excessive oil consumption is covered only during the first 100,000 miles (160,935 kilometers) of operation. Before a claim for excessive oil consumption will be considered, Owner must submit adequate documentation to show that consumption exceeds Cummins published standards.

Failures of belts are covered only during the first 15,000 miles (24,140 kilometers) or two years of operation, whichever occurs first.

Parts used in warranty repairs may be new Cummins parts, Cummins approved rebuilt parts, or repaired parts. Cummins is not responsible for failures resulting from the use of parts not approved by Cummins.

THIS WARRANTY AND THE EMISSION WARRANTY SET FORTH HEREINAFTER ARE THE SOLE WARRANTIES MADE BY CUMMINS IN REGARD TO THESE ENGINES. CUMMINS MAKES NO OTHER WARRANTIES, EXPRESS OR IMPLIED, OR OF MERCHANTABILITY OR FITNESS FOR A PARTICULAR PURPOSE.

EMISSION WARRANTY

PRODUCTS WARRANTED

This Emission Warranty applies to C Series engines marketed by Cummins that are used in the United States* in vehicles designed for transporting persons or property on a street or highway. This warranty applies to engines delivered to the ultimate purchaser on or after January 1, 1980.

COVERAGE

Cummins warrants to the ultimate purchaser and each subsequent purchaser that the engine is designed, built and equipped so as to conform at the time of sale by Cummins with all U.S. Federal emission regulations applicable at the time of manufacture and that it is free from defects in material and workmanship which would cause it not to meet these regulations within the period of five years or 100,000 miles (160,935 kilometers) or 3,000 hours of operation, whichever occurs first, as measured from the date of delivery of the engine to

the ultimate purchaser. Failures, other than those resulting from defects in materials or workmanship, which arise solely as a result of Owner abuse and/or lack of proper maintenance, are not covered in this warranty.

Cummins is not responsible for "downtime" expenses, cargo damage or any business costs or losses resulting from a warrantable failure. **CUMMINS IS NOT RESPONSIBLE FOR INCIDENTAL OR CONSEQUENTIAL DAMAGES.**

* Includes American Samoa, the Commonwealth of Northern Mariana Islands, Guam, Puerto Rico, and the U.S. Virgin Islands.

California Emission Control System Warranty

Products Warranted

This Emission Control System Warranty applies to engines certified with the California Air Resources Board beginning with the year 1985, marketed by Cummins, and sold in California for use in automotive on-highway applications.

Emission Control System Warranty

Cummins warrants that the engine at the time of sale by Cummins (1) has been designed, built and equipped to conform with applicable regulations of the U.S. Environmental Protection Agency and the California Air Resources Board, and (2) is free from defects in material and workmanship which would cause it to fail to conform with those regulations as may be applicable for a period of use of five years or 100,000 miles (160,000 kilometers) or 3,000 hours of engine operation, whichever occurs first, from the date of delivery of the engine to the first retail purchaser.

Coverage

This emission control system warranty applies only to the following emission control parts:

- Fuel Pump
 - LDA (Boost Control)
 - KSB Valve
- Injectors
- Exhaust Manifold
- Intake Manifold
- Turbocharger
- Aftercooler

Replacement Parts

Cummins recommends that any service parts used for maintenance, repair or replacement of emission control systems be new, genuine Cummins or Cummins approved rebuilt parts and assemblies, and that the engine be serviced by a Cummins distributor, authorized dealer or other repair location approved by Cummins. The owner may elect to have maintenance, replacement or repair of the emission control parts performed by a facility other than a Cummins distributor, an authorized dealer or a repair location approved by Cummins, and may elect to use parts other than new, genuine Cummins or Cummins approved rebuilt parts and assemblies for such maintenance, replacement or repair; however, the cost of such service or parts will not be covered under this emission control system warranty.

Cummins Responsibilities

Repairs and service will be performed by a Cummins distributor, authorized dealer or other repair location approved by Cummins using new, genuine Cummins or Cummins approved rebuilt parts and assemblies. Cummins will repair any of the emission control parts found by Cummins to be defective without charge for parts or labor (including diagnosis which results in a determination that there has been a failure of a warranted emission control part).

Emergency Repairs

In the case of an emergency where a Cummins distributor, authorized dealer, or other repair location approved by Cummins is not available, repairs may be performed by any available repair location. Cummins will reimburse the Owner for reasonable cost of such repairs that are covered under this warranty. Replaced parts and paid invoices must be presented at a Cummins authorized repair facility as a condition of reimbursement for emergency repairs not performed by a Cummins distributor, authorized dealer, or other repair location approved by Cummins.

Owner Responsibilities

Owner is responsible for the operation and maintenance of the engine as specified in Cummins Operation and Maintenance Manuals.

Prior to the expiration of the applicable warranty, Owner must give notice of any warranted emission control failure to a Cummins distributor, authorized dealer or other repair location approved by Cummins and deliver the engine to such facility for repair. Repair locations are listed in Cummins United States and Canada Service Directory.

Owner is responsible for communication expenses, meals, lodging and incidental costs incurred by Owner or employees of Owner as a result of a warrantable failure.

Owner is responsible for "downtime" expenses, cargo damage and all business costs and losses resulting from a warrantable failure. CUMMINS IS NOT RESPONSIBLE FOR OTHER INCIDENTAL OR CONSEQUENTIAL DAMAGES.

Warranty Limitations

Cummins is not responsible for failures resulting from Owner or operator abuse or neglect, such as: operation without adequate coolant, fuel or lubricants; overfueling; overspeeding; lack of maintenance of lubricating, cooling or air intake systems; improper storage, starting, warm-up, run-in or shut-down practices.

Cummins is not responsible for failures resulting from improper repair or the use of parts not approved by Cummins.

These warranties, together with the express commercial warranties and the emission warranty under the Clean Air Act, are the sole warranties of Cummins. There are no other warranties, express or implied, or of merchantability or fitness for a particular purpose.

Cummins Warranty - Worldwide Mobile Farming Equipment

Coverage

Products Warranted

This warranty applies to C series engines marketed by Cummins that are used in mobile farming equipment anywhere in the world where Cummins approved service is available through a Cummins distributor.

Engine Warranty

The Engine Warranty covers any failures of the engine which result, under normal use and service, from defects in workmanship or material. This coverage extends for two years or 2,000 hours of operation, whichever occurs first, from the date of delivery of the engine to the first user, except that if the 2,000 hour limit is exceeded during the first year, coverage continues until the end of the first year.

This warranty is made to all Owners in the chain of distribution and coverage continues to all subsequent Owners until the end of the period of coverage.

Cummins Responsibilities

Cummins will pay for all parts and labor needed to repair the damage to the engine resulting from the warrantable failure. All labor costs will be paid in accordance with Cummins published Standard Repair Operation guidelines.

Cummins will pay for the lubricating oil, antifreeze, filter elements, belts, hoses and other maintenance items that are not reusable due to the warrantable failure.

Cummins will pay reasonable labor costs for engine removal and reinstallation when necessary to make the warranty repair.

Cummins will pay reasonable travel expenses for mechanics to and from the engine site, including meals, mileage, and lodging when it is necessary for the mechanics to make on-site warranty repairs.

Owner Responsibilities

Owner is responsible for the cost of non-engine repairs and the cost of lubricating oil, antifreeze, filter elements, belts, hoses and other maintenance items replaced during warranty repairs unless such items are not reusable due to the warrantable failure.

Owner is responsible for the operation and maintenance of the engine as specified in Cummins Operation and Maintenance Manuals.

Before the expiration of the warranty, Owner must notify a Cummins distributor, authorized dealer or other repair location approved by Cummins of any warrantable failure and have the engine repaired by such facility. Locations in the United States and Canada are listed in the Cummins United States and Canada Sales and Service Directory; other locations are listed in the Cummins International Sales and Service Directory.

Owner is responsible for communication expenses, meals, lodging and incidental costs incurred by Owner or employees of Owner as a result of a warrantable failure.

Owner is responsible for "downtime" expenses, and all business costs and losses resulting from a warrantable failure. **CUMMINS IS NOT RESPONSIBLE FOR INCIDENTAL OR CONSEQUENTIAL DAMAGES.**

Limitations

Cummins is not responsible for failures resulting from Owner or operator abuse or neglect, such as: operation without adequate coolant, fuel or lubricants; overfueling; overspeeding; lack of maintenance of lubricating, cooling or air intake systems; improper storage, starting, warm-up, run-in or shutdown practices or for progressive damage resulting from a defective shutdown or warning device.

Cummins does not warrant accessories supplied by Cummins which bear the name of another company. These accessories are warranted by their respective manufacturers and not by Cummins. This category includes, but is not limited to: alternators, starters, non-Cummins air compressors, clutches, air cleaners, fans, transmissions, torque converters, hydraulic pumps, and air conditioning compressors.

This warranty is void and non-binding on Cummins if, at the time of failure, the engine is determined to have been modified so as to substantially alter its operating characteristics.

Before a claim for excessive oil consumption will be considered, Owner must submit adequate documentation to show that consumption exceeds Cummins published standards.

Failures caused by incorrect adjustment of valves or injectors are covered only during the first 1,500 hours of operation and only during the first year.

During the first year, failures caused by improper fuel pump or injector calibration are covered only during the first 4,500 hours of operation.

Failures of unknown cause resulting in scuffed piston rings, scored pistons or liners, or seized pistons are covered only during the first 500 hours of operation.

Failures of belts are covered only during the first 500 hours of operation.

Only new Cummins or Cummins approved rebuilt parts will be used in making warranty repairs. Cummins is not responsible for failures resulting from improper repair or the use of parts not approved by Cummins

THE WARRANTY SET FORTH HEREIN IS THE SOLE WARRANTY MADE BY CUMMINS IN REGARD TO THESE ENGINES. CUMMINS MAKES NO OTHER WARRANTIES, EXPRESS OR IMPLIED, OR OF MERCHANTABILITY OR FITNESS FOR A PARTICULAR PURPOSE.

Cummins Warranty - Worldwide Industrial and Marine

WARRANTY SCHEDULE

Application	Duration (whichever occurs first)	
	Months	Hours
Industrial/Construction/Marine	12	-
Mobile Farming Equipment	24	2,000*
Other Farming Equipment	12	-

* If the 2,000 hour limit is exceeded during the first year, coverage continues until the end of the first year.

COVERAGE

This warranty applies to the following Products sold by Cummins that are used in the above applications anywhere in the world where Cummins approved service is available, except the United States and Puerto Rico:

1. Non-automotive B and C Series engines, except those powering generator sets.
2. Power units powered by B and C Series engines. These products are identified by the letter P on the Product data plate.

This warranty applies to Products delivered to the first user on or after March 1, 1987. Any failure of the Product which results, under normal use and service, from a defect in material or workmanship (Warrantable Failure) is covered beginning on the date of delivery of the Product to the first user** and continuing for the Duration stated above, except that the Duration on starters, alternators and non-Cummins air compressors and power

steering pumps in applications other than fire pump drive engines, marine engines and power units is 6 months.

This warranty is made to all Owners in the chain of distribution, and coverage continues to all subsequent Owners until the end of the Duration stated.

** For engines in recreational boats, the duration begins on the date of delivery to the first retail purchaser.

CUMMINS RESPONSIBILITIES

Cummins will pay for all parts and labor needed to repair the damage to the Product resulting from the Warrantable Failure. Labor costs will be paid in accordance with Cummins published Standard Repair Time guidelines.

Cummins will pay for the lubricating oil, antifreeze, filter elements and other maintenance items that are not reusable due to the Warrantable Failure.

Cummins will pay reasonable travel expenses for mechanics to and from the equipment site, or repair dock in the case of a marine application, when it is necessary for mechanics to make on-site warranty repairs.

OWNER RESPONSIBILITIES

Owner is responsible for the operation and maintenance of the Product as specified in the Cummins Operation and Maintenance Manual.

Before the expiration of this warranty, Owner must notify a Cummins Distributor, authorized B and C Series dealer or other repair location approved by Cummins of any Warrantable Failure and have the failure repaired by such facility. Locations are listed in the Cummins International Sales and Service Directory.

Owner is responsible for the cost of lubricating oil, antifreeze, filter elements and other maintenance items replaced during warranty repairs unless such items are not reusable due to the Warrantable Failure.

In the event of any marine Product failure, Owner is responsible for the cost of towing the boat to the repair dock and for any associated docking and harbor charges.

Owner is responsible for communication expenses, meals, lodging and similar costs incurred by Owner as a result of a Warrantable Failure.

Owner is responsible for non-product repairs and for "downtime" expenses, cargo damage, and all business costs and losses resulting from a Warrantable Failure. **CUMMINS IS NOT RESPONSIBLE FOR INCIDENTAL OR CONSEQUENTIAL DAMAGES.**

LIMITATIONS

This warranty is void and nonbinding on Cummins if, at the time of failure, the Product is determined to have been modified so as to substantially alter its operating characteristics.

Cummins is not responsible for failures resulting from Owner or operator abuse or neglect such as: operation without adequate coolant or lubricants; overfueling; overspeeding; lack of maintenance of lubricating, cooling or air intake systems; improper storage, starting, warm-up, run-in, or shutdown practices. Cummins is also not responsible for failures caused by incorrect fuel, or by water, dirt, or other contaminants in the fuel.

With certain exceptions, this warranty does not apply to accessories supplied by Cummins which bear the name of another company. The exceptions to which the warranty does apply are:

1. Fuel pumps, starters, alternators, air compressors and power steering pumps.
2. Components, other than filters, furnished by Cummins as part of a marine engine, power unit, or fire pump drive engine.

Examples of accessories to which the warranty does not apply are: air conditioning compressors, clutches, air cleaners, fans, filters, transmissions, torque converters and hydraulic pumps.

Before a claim for excessive oil consumption will be considered, Owner must submit adequate documentation to show that consumption exceeds Cummins published standards.

Failures of belts will be covered for the duration of the warranty or 500 hours, whichever occurs first.

Parts used in warranty repairs may be new Cummins parts, Cummins approved rebuilt parts, or repaired parts. Cummins is not responsible for failures resulting from the use of parts not approved by Cummins.

As to consumer applications of the Products used in the United Kingdom, nothing in this warranty is to be taken as in any way excluding or restricting any statutory rights that any purchaser of such Products may have against his supplier.

THE WARRANTY SET FORTH HEREIN IS THE SOLE WARRANTY MADE BY CUMMINS IN REGARD TO THESE PRODUCTS. THERE ARE NO OTHER WARRANTIES, EXPRESS OR IMPLIED, OR OF MERCHANTABILITY OR FITNESS FOR A PARTICULAR PURPOSE.

Section 0 - Introduction

Table of Contents

Subject	Page
About the Manual	0-2
Symbols Used in this Manual	0-3
Abbreviations Used in this Manual.....	0-4
Illustrations	0-5
Safety Precautions and Warnings	0-6
To the Engine Owner and Operator	0-8
How to Identify Your Engine	0-9
Engine Dataplate	0-10
Fuel Pump Dataplate	0-11
External Engine Components.....	0-12

About the Manual
Page 0-2

Introduction
C Series

About the Manual

This manual is designed to provide:

- Warranty Information
- Description and Specifications of the Engine
- Engine Operation Procedures
- Engine Maintenance Procedures
- Troubleshooting Procedures
- Adjustment and Replacement Procedures
- A List of Authorized Service Locations

Cummins Engine Company, Inc., is continuously improving its products. If you find differences between your engine and the information contained in this manual, contact your local Cummins authorized repair location.

If you sell the engine, give this manual to the new owner.

Symbols

Become familiar with the symbols, used throughout the manual, to identify the action or procedure required.



WARNING - Personal safety is involved in the performance of the procedure.



CAUTION - Follow the instructions to avoid engine, part, or assembly damage.



Indicates a **REMOVAL** or **DISASSEMBLY** step.



Indicates an **INSTALLATION** or **ASSEMBLY** step.



INSPECTION is required.



CLEAN the part or assembly.



PERFORM a mechanical or time **MEASUREMENT**.



LUBRICATE the part or assembly.



Indicates that a **WRENCH** or **TOOL SIZE** will be given.



TIGHTEN to a specific torque.



PERFORM an electrical **MEASUREMENT**.



Refer to another location in this manual or another publication for additional information.

Abbreviations Used In This Manual Page 0-4

Introduction C Series

Abbreviations Used In This Manual

API	American Petroleum Institute	in-lb	Inch Pound
ASTM	American Society of Testing and Materials	kg	Kilograms
°C	Centigrade	km	Kilometers
C.I.D.	Cubic Inch Displacement	kPa	Kilopascal
CPL	Control Parts List	m	metre
cSt	Centistokes	mm	Millimetre
DCA	Diesel Coolant Additive	MPa	Megapascal
E.C.S.	Emission Control System	MPQ	Miles Per Quart
EPA	Environmental Protection Agency	N•m	Newton-metre
°F	Fahrenheit	OEM	Original Equipment Manufacturer
ft-lb	Foot Pound	ppm	Parts Per Million
GVW	Gross Vehicle Weight	psi	Pounds Per Square Inch
Hg	Mercury	RPM	Revolutions Per Minute
HP	Horsepower	S.A.E.	Society of Automotive Engineers
H ₂ O	Water	S.O.	Shop Order

Illustrations

Use the illustrations in this manual as a guide to perform the action or the repair described. Many illustrations are generic and will not look exactly like the engine or the parts used in your application. In order to provide clarity to illustrations, some illustrations show parts removed that are not related to the specific parts given in the text.

Most of the illustrations contain symbols to indicate an action required or to indicate an acceptable (OK) or unacceptable (not OK) condition.

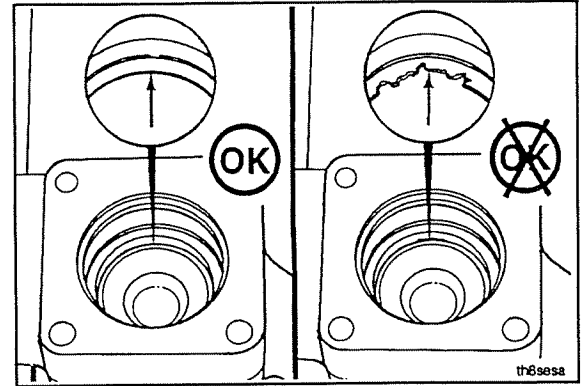

General Safety Precautions and Warnings







! Warning: This symbol appears in the manual when a potential safety hazard exists that can cause personal injury or death. These hazards are not always apparent to a trained mechanic.

Note: It is not possible for Cummins Engine Company, Inc. to anticipate every possible circumstance that can involve a potential hazard.

Read and understand all of the safety precautions and warnings before performing any repair. This list contains the general safety precautions that must be followed to provide personal safety. Special safety precautions are included in the procedures when they apply.

- !** Warning: Disconnect the battery and discharge any capacitors before beginning any repair work. Disconnect the air starter, if equipped, to prevent accidental engine starting. Put a "Do Not Operate" tag in the operator's compartment or on the controls.
- !** Warning: Use ONLY the correct engine barring techniques for manually rotating the engine. Do not attempt to rotate the engine by pulling or prying on the fan. This practice can cause serious personal injury, property damage, or damage to the fan blade(s), causing premature fan failure.
- !** Warning: If an engine has been operating and the coolant is hot, allow the engine to cool before you slowly loosen the filler cap and relieve the pressure from the cooling system.
- !** Warning: Do not work on anything that is supported ONLY by lift jacks or a hoist. Always use blocks or correct stands to support the product before performing any service work.

General Safety Precautions and Warnings (Continued)

-  Warning: To avoid burns, be alert for hot component parts just after the engine has been shut off and hot fluids in lines, tubes, and compartments.
-  Warning: Relieve all pressure in the air, the oil, and the cooling systems before any lines, fittings, or related items are removed or disconnected. Be alert for possible pressure when disconnecting any device from a system that utilizes pressure. Do not check for pressure leaks with your hand. High pressure oil or fuel can cause personal injury.
-  Warning: To prevent suffocation and frostbite, wear protective clothing and ONLY disconnect liquid refrigerant (freon) lines in a well ventilated area.
-  Warning: Corrosion inhibitor contains alkali. Do not get the substance in your eyes. Avoid prolonged or repeated contact with skin. Do not swallow internally. In case of contact, immediately wash skin with soap and water. In case of contact, immediately flood eyes with large amounts of water for a minimum of 15 minutes. IMMEDIATELY CALL A PHYSICIAN. KEEP OUT OF REACH OF CHILDREN.
-  Warning: Always use tools that are in good condition. Make sure you understand how to use them before performing any service work.
-  Warning: Always use the same fastener part number (or equivalent) when replacing fasteners. Do not use a fastener of lesser quality if replacements are necessary.
-  Warning: Never use gasoline or other flammable materials to clean parts. Always use approved cleaning solvents.

To the Engine Owner and Operator
Page 0-8

Introduction
C Series

To the Engine Owner and Operator

Preventative maintenance is the easiest and least expensive type of maintenance. Follow the maintenance schedule recommendations outlined in *Maintenance Guidelines* (Section 2).

Keep records of regularly scheduled maintenance.

Use the correct fuel, oil, and coolant in your engine as specified in *Engine Specifications* (Section 5).

Cummins uses the latest technology and the highest quality components to produce its engines. Cummins recommends using only genuine Cummins parts and ReCon® exchange parts.

Personnel at Cummins authorized repair locations have been trained to provide expert service and parts support. If you have a problem that cannot be resolved by a Cummins authorized repair location, follow the steps outlined in the *Cummins Owner Assistance* (Section 6).

How To Identify Your Engine

The model name provides the following engine data:

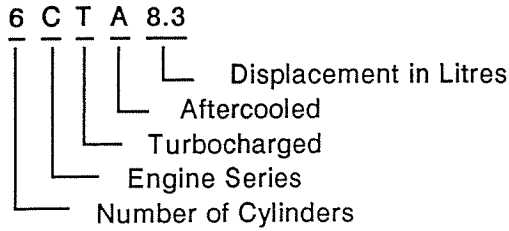

Engine Dataplate Page 0-10

Introduction C Series

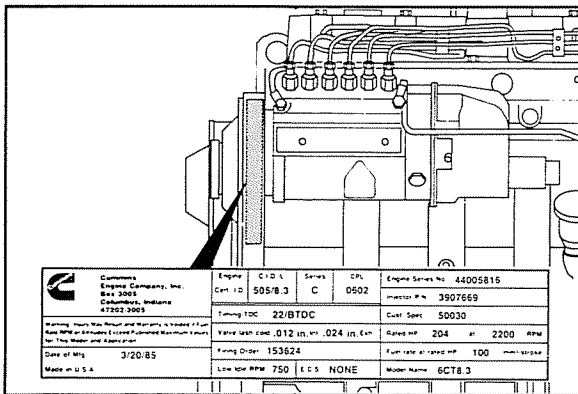

Engine Dataplate

The engine dataplate shows specific information about your engine. The engine serial number (1) and Control Parts List (CPL) (2) provide information for ordering parts and service needs.

 Cummins Engine Company, Inc. Box 3005 Columbus, Indiana 47202-3005	Engine Cert. I.D.	C.I.D./L. 505/8.3	Series C	CPL 0602	Engine Series No. 44005816
					Injector P/N. 3907669
	Timing-TDC 22/BTDC				Cust. Spec. 50030
	Valve lash cold .012 in. Int. .024 in. Exh.				Rated HP 204 at 2200 RPM
	Firing Order 153624				Fuel rate at rated HP 100 mm ³ /stroke
	Date of Mfg. 3/20/85		Low Idle RPM 750	E.C.S. NONE	Model Name 6CT8.3
<small>Warning: Injury May Result and Warranty is Voided if Fuel Rate RPM or Altitudes Exceed Published Maximum Values for This Model and Application.</small>					
<small>Made in U.S.A.</small>					



Fuel Pump Dataplate (Nameplate)

The fuel pump dataplate is located on the side of the fuel pump. It provides information for fuel pump calibration.

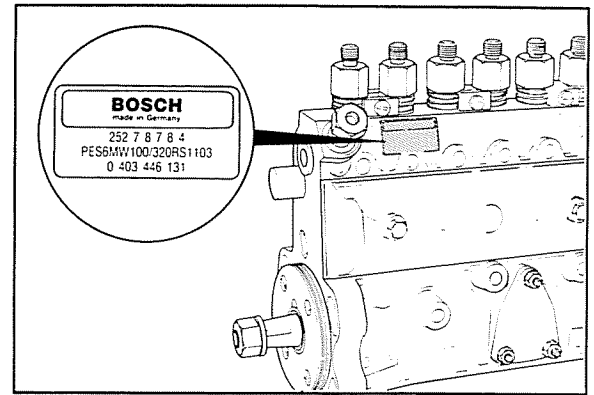

The Cummins part number for the fuel pump-governor combination is located on the governor dataplate.

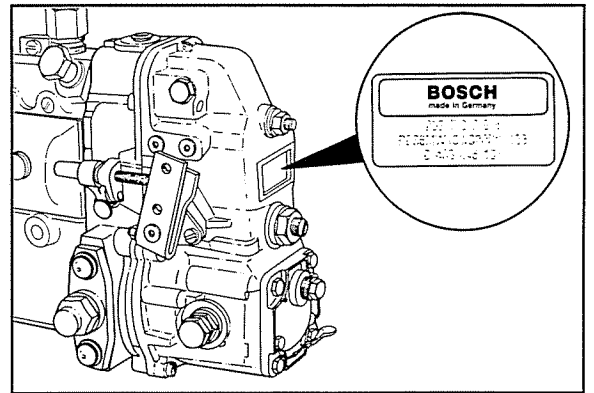

External Engine Components

The pictures which follow show the locations of the major external engine components, the filters, and other service and maintenance points. Some external components will be at different locations for different engine models.

Note: The pictures are only a reference to show a typical engine.

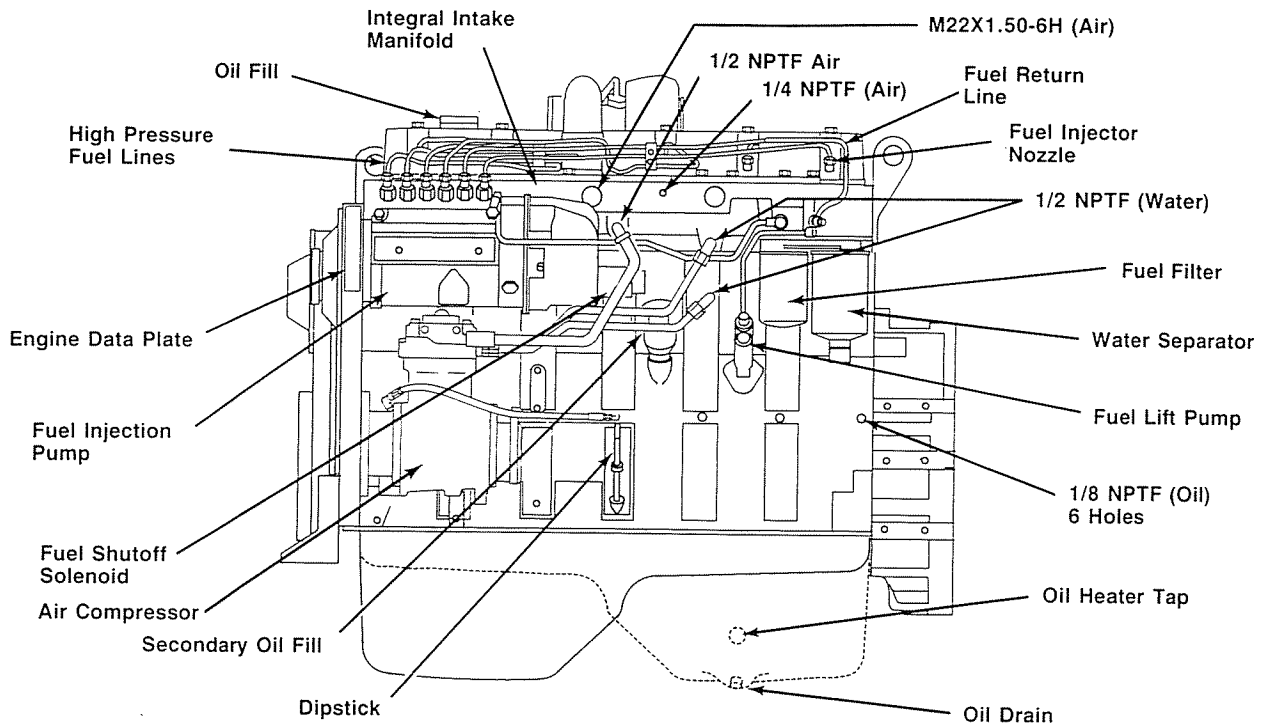

Fuel Pump Side View

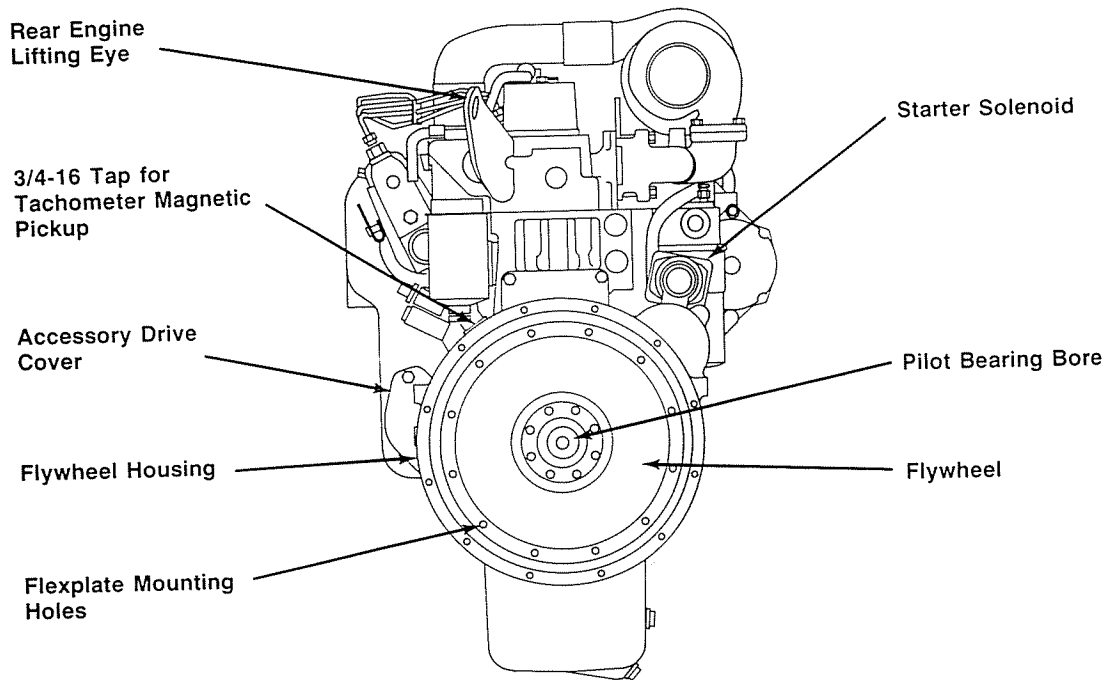

Rear View

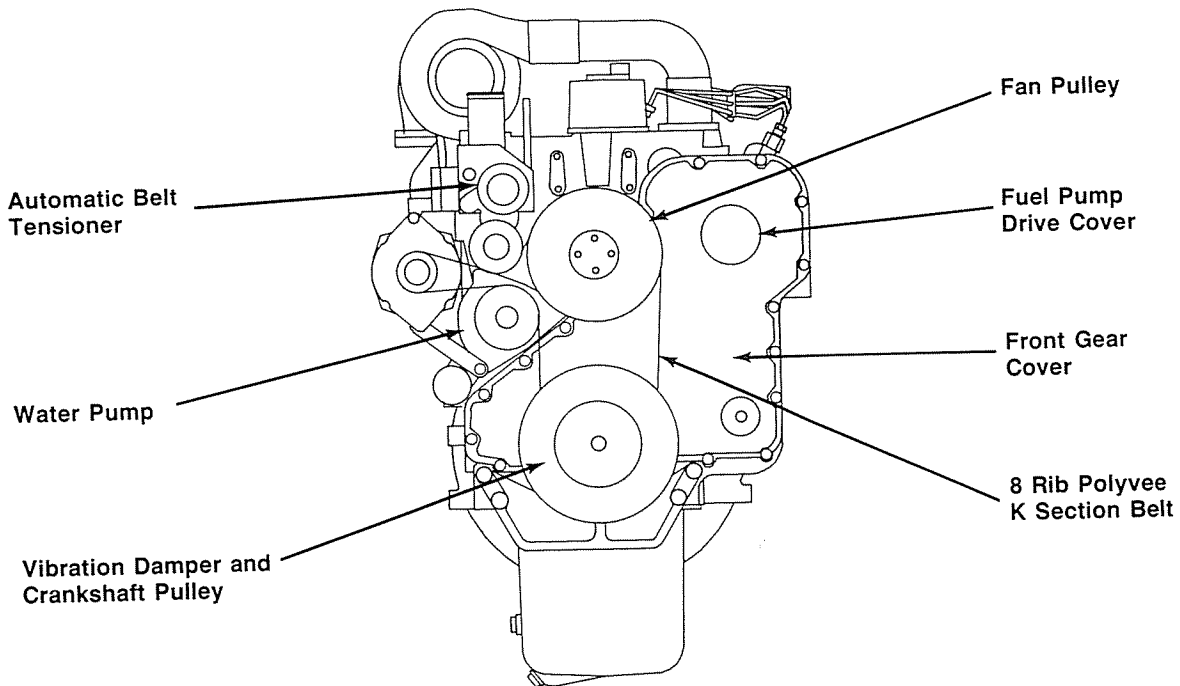
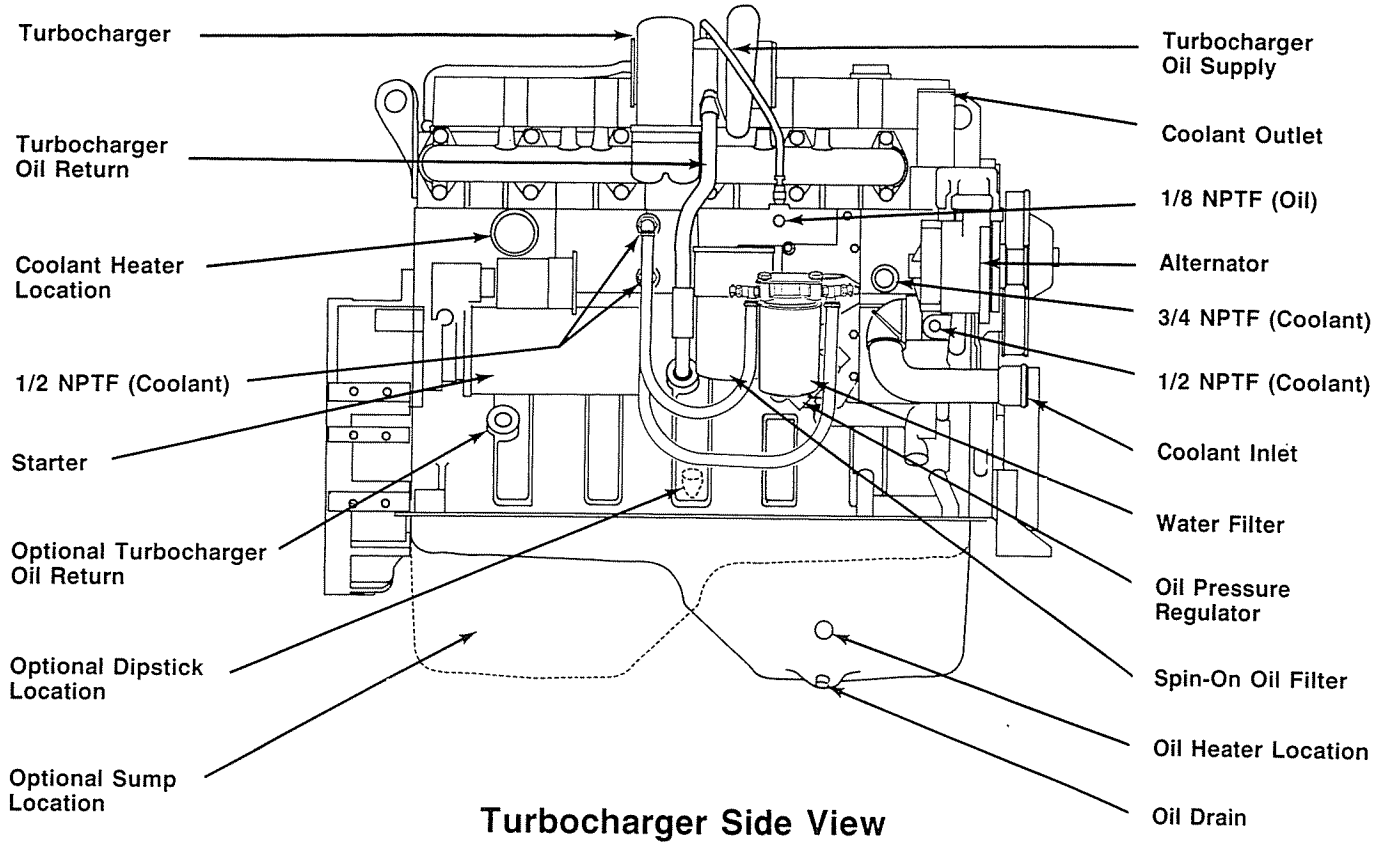

Section 1 - Operating Instructions

Table of Contents

Subject	Page
General	1-2
Normal Starting Procedure	1-2
Cold Weather Starting Aids.....	1-3
Cold Weather Starting with Starting Fluid	1-4
Operating the Engine.....	1-5
Prevent Engine Overspeed.....	1-6

General

Proper care of your engine will result in longer life, better performance, and more economical operation.

- Follow the daily maintenance checks listed in Section 2.
- Check the oil pressure indicator(s), temperature indicator(s), warning light(s), and other gauges daily to make sure they are operational.

Normal Starting Procedure

- Disengage the driven unit or put the transmission in neutral.
- Position the fuel shutoff, electrical switch or mechanical control, to the run position.
- On industrial equipment, set the throttle at idle. To start a cold automotive engine, depress the accelerator pedal to the floor and release the pedal before engaging the starter.

Note: Industrial engines are equipped with Robert Bosch RSV governors which automatically position the internal pump controls to the start position for maximum fuel delivery when the throttle is set at idle. Automotive engines with Bosch RQV governors will normally start with partial throttle but must be manually pre-set for maximum fuel delivery by depressing the accelerator all the way and releasing the pedal before engaging the starter.

Caution: To prevent damage to the starter, do not engage the starting motor more than 30 seconds. Wait two minutes between each attempt to start.

- Engine oil pressure must be indicated on the gauge within 15 seconds after starting.
- When starting a cold engine, increase the engine speed (RPM) slowly to be sure adequate lubrication is available to the bearings and to allow the oil pressure to stabilize.
- Idle the engine 3 to 5 minutes at 1,000 RPM before operating with a load.

Cold Weather Starting Aids

Use following chart as a reference for required cold weather starting aids.

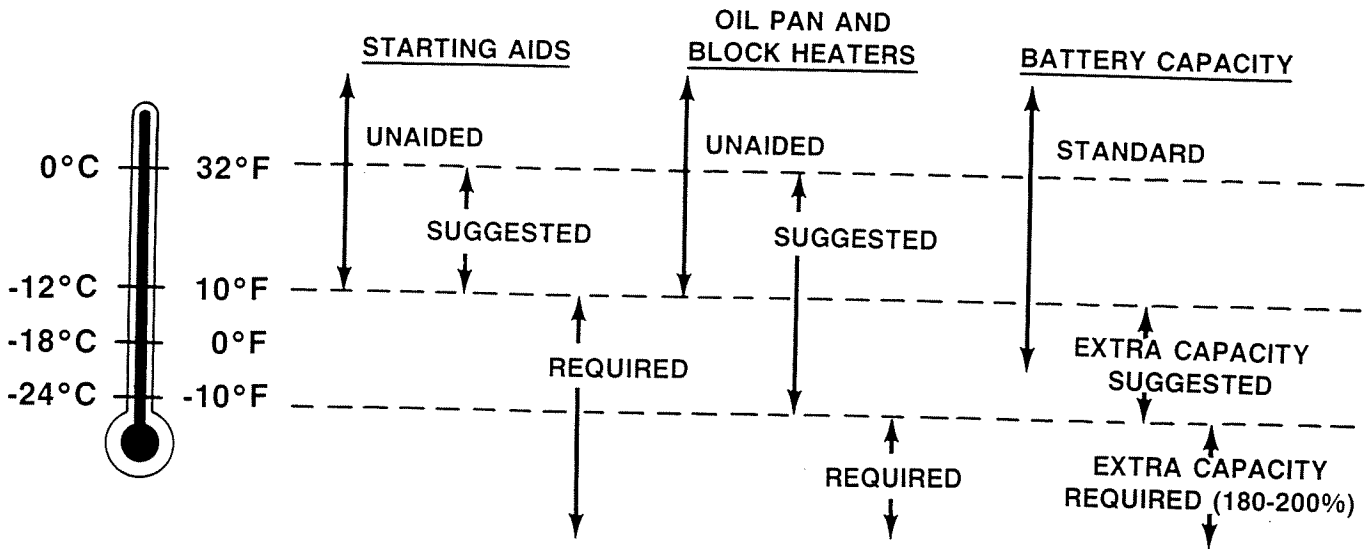

Cold Weather Starting With Starting Fluid Section 1-4

Cold Weather Starting With Starting Fluid Using Mechanical Or Electrical Metering Equipment

- On industrial equipment, set the throttle at idle. For automotive engines, depress the accelerator pedal all the way to the start position and release the pedal.
- Industrial engines are equipped with Robert Bosch RSV governors which automatically position the pump controls to the start position when the throttle is set at idle. Automotive engines are equipped with Bosch RQV governors. The accelerator pedal must be depressed all the way to the start position and then released before starting the engine.
- Disengage the driven unit or put the transmission in neutral.
- Position the fuel shutoff, electrical switch or mechanical control, to the run position.
- While cranking the engine, inject metered amounts of starting fluid.

Cold Weather Starting With Starting Fluid Using Mouth Metering Equipment

- ▲ **Warning:** Never use starting fluid near an open flame or with a preheater or flame thrower equipment.
- ▲ Do not breathe the fumes. Use of too much starting fluid will cause engine damage.
- Spray starting fluid into the air cleaner intake while another person cranks the engine.
- ▲ **Warning:** Do not use volatile cold starting aids in underground mine or tunnel operations. Check with the local U.S. Bureau of Mines Inspector for instructions.

Operating the Engine

- Do not operate the engine at full throttle below peak torque engine speed (RPM) for extended periods (more than a minute) of time.
- Allow the engine to idle 3 to 5 minutes before shutting it off after a full load operation.
- Monitor the oil pressure and coolant temperature gauges frequently. Refer to **Engine Specifications** (Section 5) for recommended operating pressures and temperatures. Shut the engine off if any pressure or temperature does not meet the specifications.

 **Caution:** Continuous operation with low coolant temperature (below 60° C [140° F]) or high coolant temperature (above 100° C [212° F]) can damage the engine.

- If an overheating condition starts to occur, reduce engine speed or shift to a lower gear, or both, until the temperature returns to normal operating range. If engine temperature does not return to normal, refer to **Troubleshooting** (Section 3) or contact a Cummins authorized repair location.
- Most failures give an early warning. Look and listen for changes in performance, sound, or engine appearance that can indicate service or engine repair is needed. Some changes to look for are:
 - Engine misfires
 - Vibration
 - Unusual engine noises
 - Fuel, oil or coolant leaks
 - Sudden changes in engine operating temperature or pressure
 - Excessive smoke
 - Loss of power
 - An increase in oil consumption
 - An increase in fuel consumption

Prevent Engine Overspeed

 **Caution:** Engine overspeed (engine speed exceeds high idle, no load RPM) can damage the engine.

When descending a steep grade, use a combination of the transmission gears and service brakes to control the vehicle speed and engine RPM.

Section 2 - Maintenance Guidelines

Table of Contents

Subject	Page
Maintenance Schedule	2-2
Maintenance Schedule Chart.....	2-3
Maintenance Record.....	2-4
Maintenance Tools Required	2-6
Daily Maintenance	2-7
Maintenance Required at each 8,000 KM	2-10
Maintenance Required at each 16,000 KM.....	2-17
Maintenance Required at 33,000 KM	2-25
Maintenance Required at Every 64,000 KM	2-35

Maintenance Schedule
Page 2-2

Maintenance Guidelines
C Series

Maintenance Schedule

Use the maintenance schedule on the next page as a guide. If the engine is operating in ambient temperatures consistently below -18°C [0°F] or above 38°C [100°F], perform maintenance at shorter intervals. Shorter maintenance intervals are also required if the engine is operated in a dusty environment or if frequent stops are made. See your Cummins authorized repair location for recommended intervals.

Daily Maintenance

Preventative maintenance begins with a day-to-day awareness of the condition of the engine and its systems.

Before starting the engine check the oil and coolant levels. Look for:

- Leaks
- Loose or damaged parts
- Worn or damaged belts
- Any change in engine appearance

Oil Level - Checking

Caution: Never operate the engine with the oil level below the "L" (Low) mark or above the "H" (High) mark. Wait at least 5 minutes after shutting off the engine to check the oil. This allows time for the oil to drain to the oil pan.

Low to High = 3.6 Litres [4 U.S. Quarts]

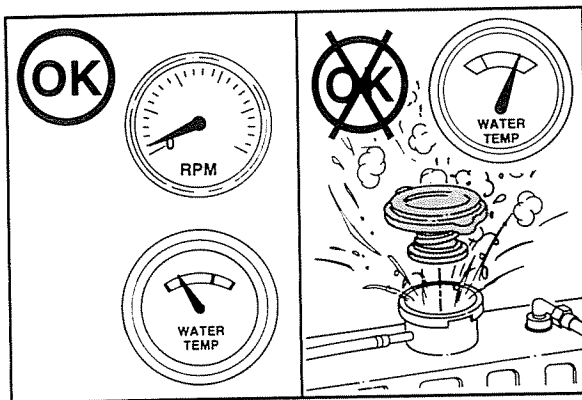
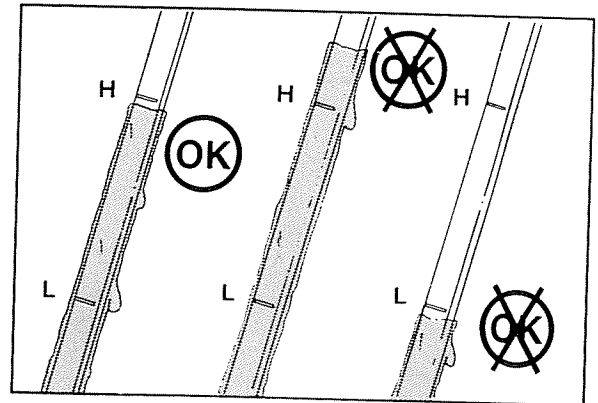

Coolant Level - Checking

Warning: Check the coolant level only when the engine is stopped. Wait until the temperature is below 70° C [160° F] before removing the pressure cap. Failure to do so can cause personal injury from heated coolant spray.



Remove the filler cap slowly to relieve coolant system pressure.

Note: Never use a sealing additive to stop leaks in the coolant system. This can result in coolant system plugging and inadequate coolant flow.

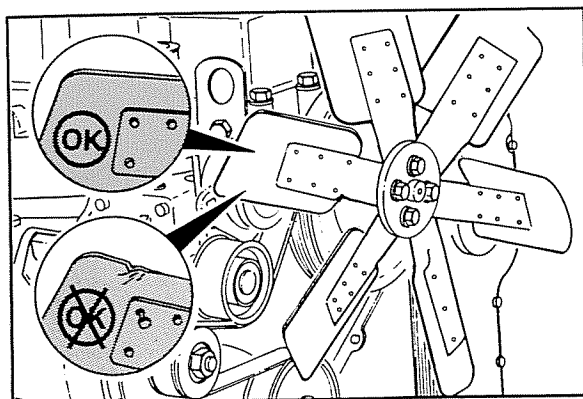

Fan - Inspection



Warning: Never use the fan to rotate the engine. The blade(s) can be damaged causing a fan failure which can result in personal injury or property damage. Use the engine barring tool or threaded dowels temporarily installed in the front of the crankshaft (Refer to Page 2-26).

Check the fan for cracks, loose rivets and bent or loose blades. Make sure it is securely mounted. Tighten the capscrews if loose. Replace damaged fans.

Drive Belt - Inspection

Visually inspect the belt. Check the belt for intersecting cracks. Transverse (across the belt width) cracks are acceptable. Longitudinal (direction of belt length) cracks that intersect with transverse cracks are not acceptable. Replace the belt if it is frayed or has pieces of material missing. Refer to Adjustment and Replacement (Section 4).

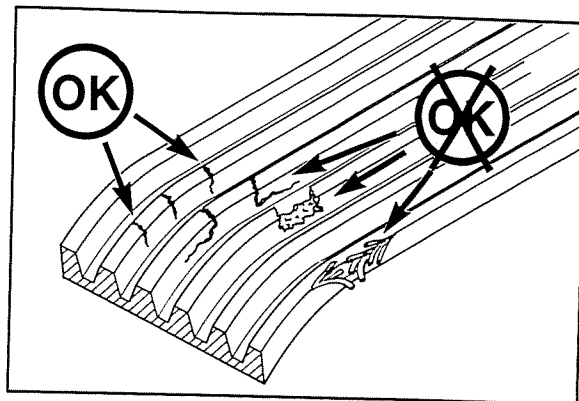

Fuel-Water Separator - Draining Water and Sediment

Open the valve on the bottom of the fuel filter to allow water to drain. Close the drain when clean fuel is visible.

Caution: Do not over-tighten the plastic valve.

Note: Also drain the sediment bowl on the pre-filter if one is installed between the lift pump and the supply tank.

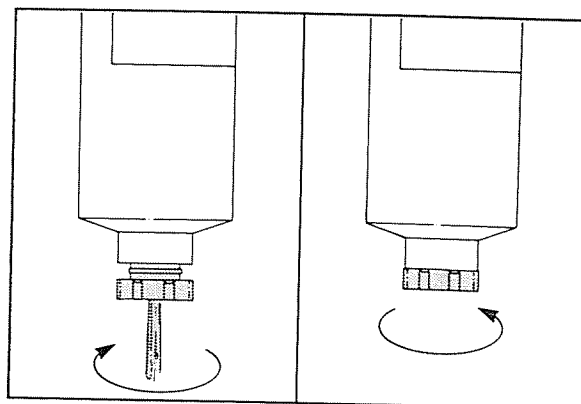

Maintenance Required at Each 8,000 KM Page 2-10

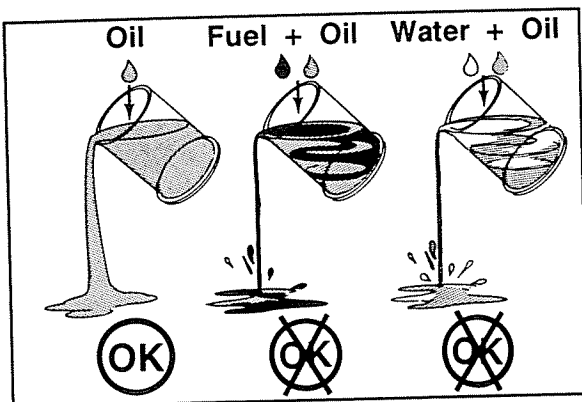

Maintenance Required at Each 8,000 KM [5,000 Miles], 250 Hours, or 3 Months Interval

Perform the daily maintenance checks plus the following.

Lubricating Oil and Filter - Change Interval

Engine oil becomes contaminated, and essential oil additives are depleted with use.

The amount of contamination is related to the total amount of fuel and oil consumed.



Caution: If the engine is being operated, under no circumstances can the oil drain interval extend beyond 8,000 km [5,000 miles], 250 hours, or 3 months.

Change the oil and filters to remove the contaminants suspended in the oil.

Note: Drain the oil only when it is hot and the contaminants are in suspension.

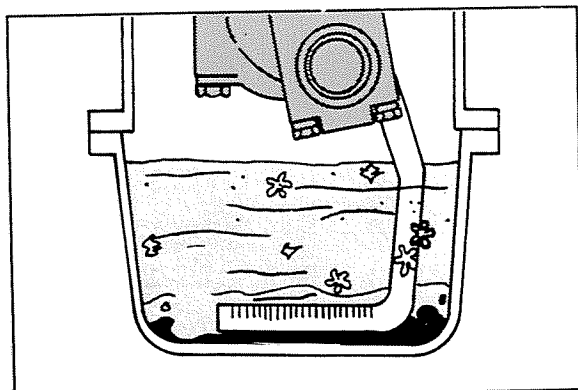

**Maintenance Guidelines
C Series**

17 mm

Warning: Hot oil can cause personal injury.

Operate the engine until the water temperature reaches 60° C [140° F]. Shut the engine off. Remove the oil drain plug.

Note: Use a container that can hold at least 22 litres (23 U.S. qts.) of oil.

Maintenance Required at Each 8,000 KM
Page 2-11

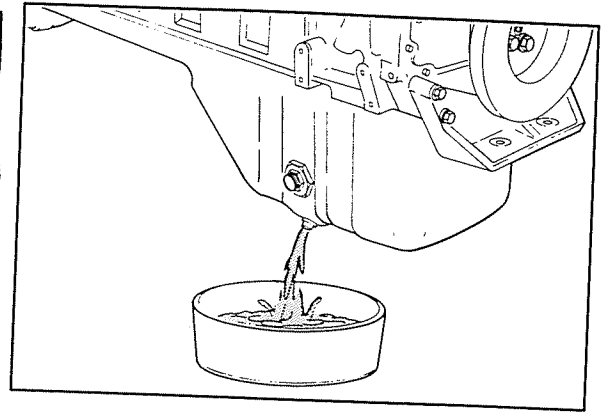

118 to 131 mm Filter Wrench

Clean the area around the lubricating oil filter head. Remove the filter. Clean the gasket surface of the filter head.

Note: The O-ring can stick on the filter head. Make sure it is removed.

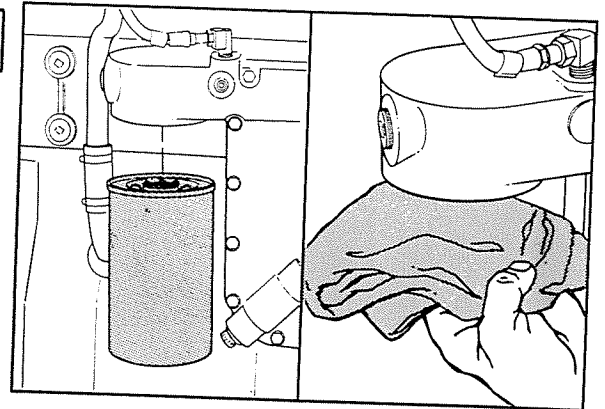

Maintenance Required at Each 8,000 KM
Page 2-12

Maintenance Guidelines
C Series

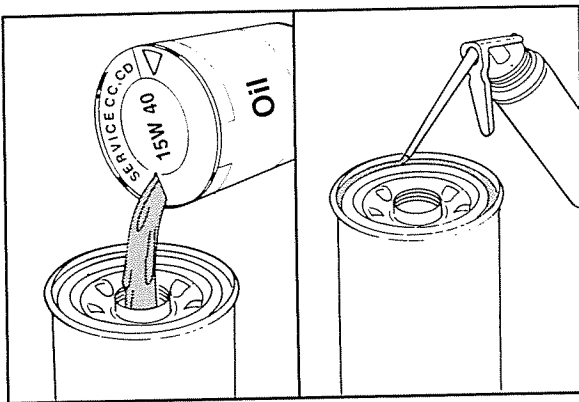

Caution: Fill the filters with clean lubricating oil before installation.

Apply a light film of lubricating oil to the gasket sealing surface before installing the filters.

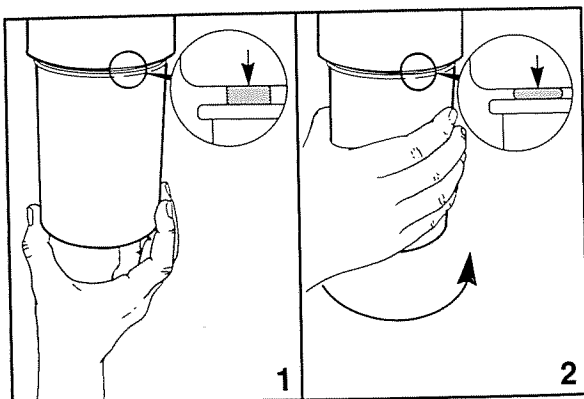

Caution: Mechanical over-tightening may distort the threads or damage the filter element seal.

Install the filter as specified by the filter manufacturer.

**Maintenance Guidelines
C Series**

17 mm

Check and clean the oil drain plug threads and sealing surface.

Install the oil pan drain plug. Tighten to 80 N•m [60 ft-lbs] torque.

NOTE: Use a high quality 15W-40 multi-viscosity oil, such as Cummins Premium Blue, or its equivalent in Cummins engines. Choose the correct oil for your operating climate as outlined in Section 5.

- Turbocharged engines CE/SF
- Naturally aspirated engines CC/CD

**Maintenance Required at Each 8,000 KM
Page 2-13**

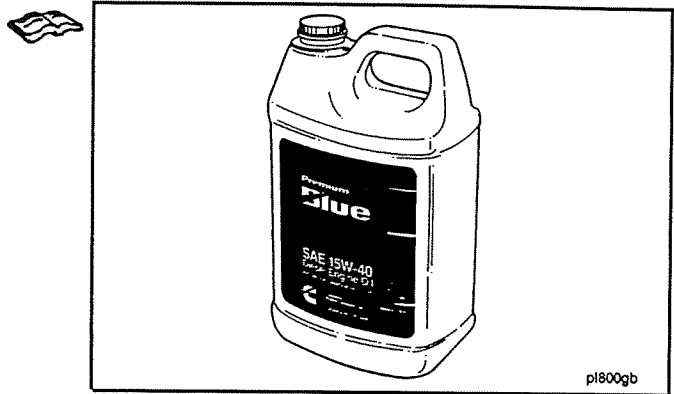
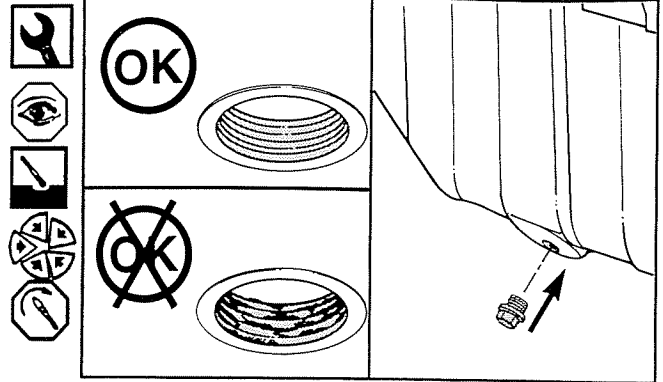

**Maintenance Required at Each 8,000 KM
Page 2-14**

**Maintenance Guidelines
C Series**

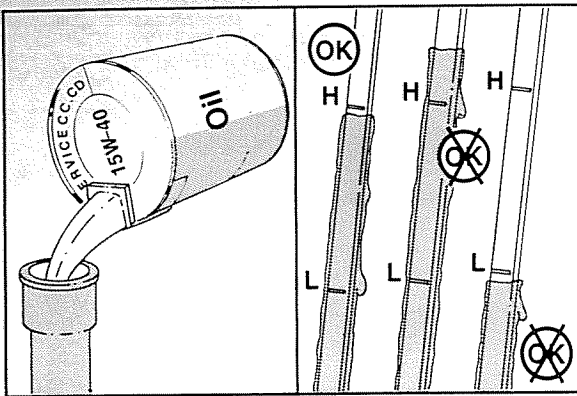

Fill the engine with clean oil to the proper level. Total system capacity including the filter is 22.4 litres [23.7 U.S. quarts].

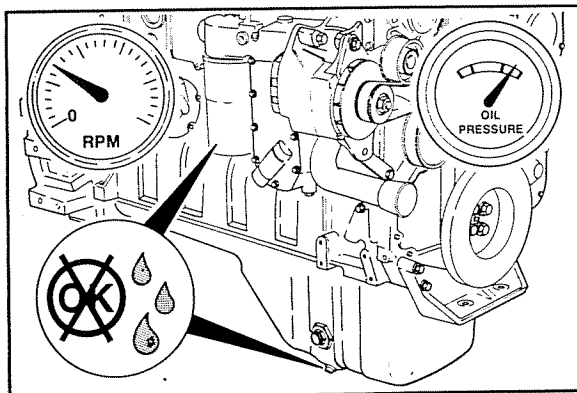

Idle the engine to inspect for leaks at the filters and the drain plug.

Maintenance Guidelines C Series

Stop the engine. Wait approximately 5 minutes to let the oil drain from the upper parts of the engine. Check the oil level again.

Add oil as necessary to bring the oil level to the "H" (High) mark on the dipstick.

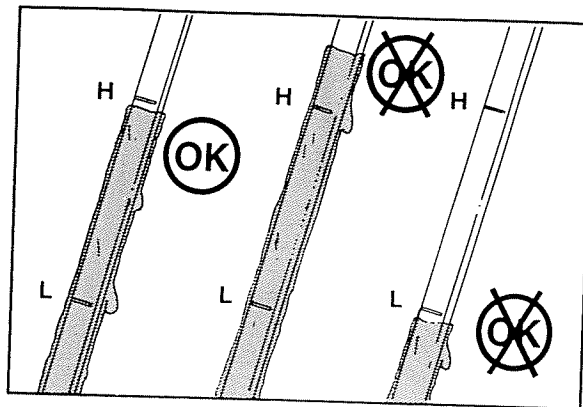

Maintenance Required at Each 8,000 KM
Page 2-15

Air Intake System - Inspection

Inspect the intake piping for cracked hoses, loose clamps, or punctures which may damage the engine.

Tighten or replace parts as necessary to make sure the air intake system does not leak.

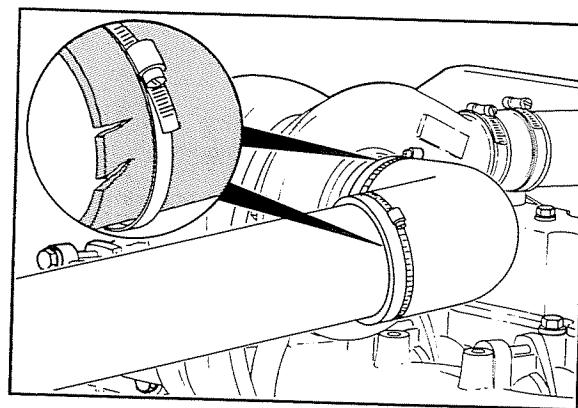

Maintenance Required at Each 8,000 KM
Page 2-16

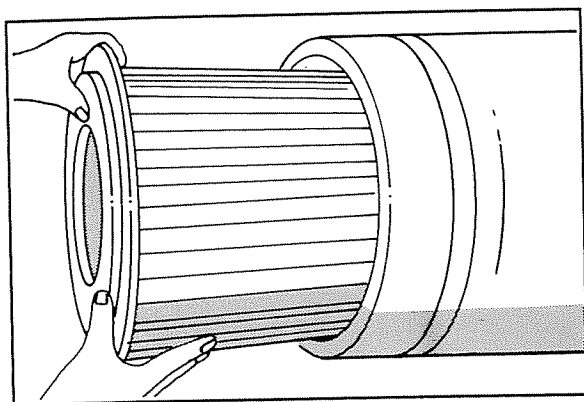

Maintenance Guidelines
C Series

Air Cleaner Element - Inspection

Maximum intake air restriction is 635 mm [25.0 in.] of water for turbocharged engines. Naturally aspirated engines have a maximum restriction of 510 mm [20.0 in.] of water.

Turbocharged engines must be operated at rated RPM and full load to check maximum intake air restriction. Replace the air cleaner element when the restriction reaches the maximum allowable limit or clean according to the manufacturer's recommendations.

Note: Follow the manufacturer's instructions when cleaning or replacing the air cleaner element.

Check the air cleaner service indicator, if equipped. Change the filter element when the red indicator flag is at the raised position.



Caution: Never operate the engine without an air cleaner. Intake air must be filtered to prevent dirt and debris from entering the engine and causing premature wear.

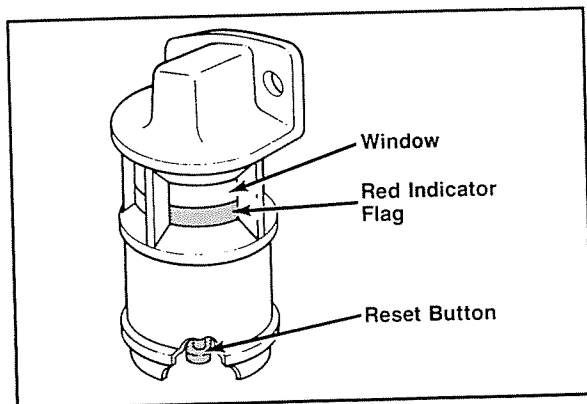

Maintenance Required at Each 16,000 KM [10,000 Miles], 500 Hours, or 6 Months Interval

Perform the 3 months or 250 hours maintenance and the following.

Fuel Filter - Replacement

75-80 mm and 90-95 mm

Clean the area around the fuel filter head. Remove the filters. Clean the gasket surface of the filter head.

Replace the o-ring.

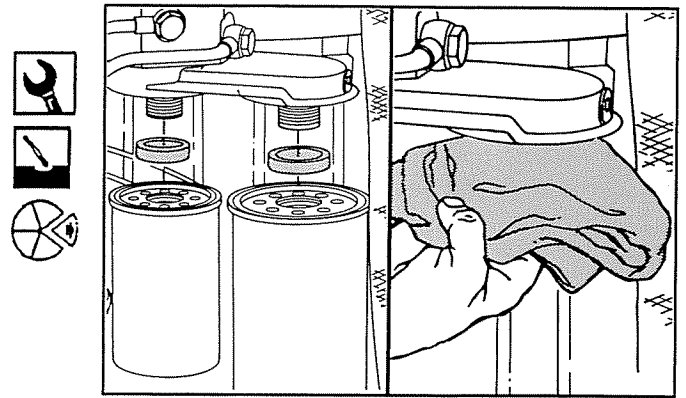

Maintenance Required at Each 16,000 KM Page 2-18

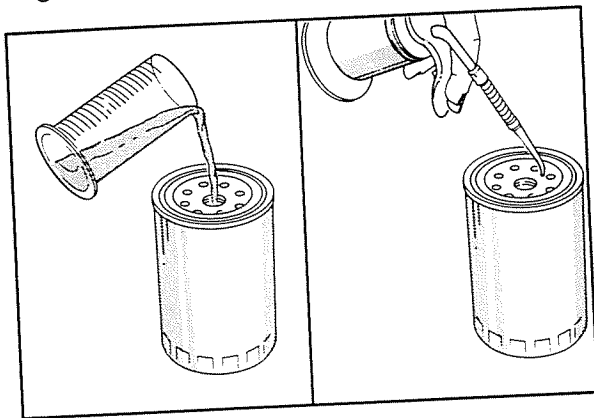

Fill the new filter(s) with clean fuel and lubricate the o-ring seal with clean lubricating oil.

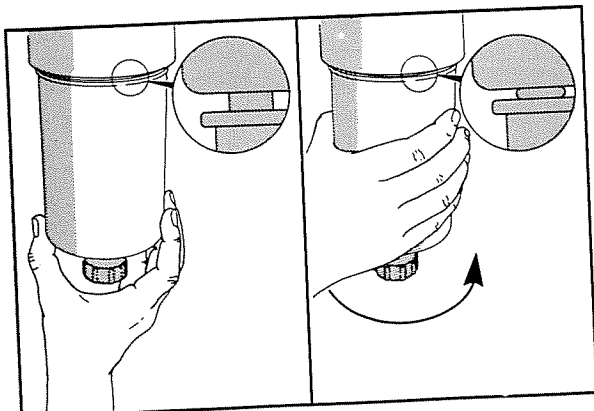

Caution: Mechanical over-tightening may distort the threads or damage the filter element seal.
Install the filter as specified by the filter manufacturer.

Low Pressure Lines and Fuel Filter(s) - Venting

8 mm

Open the bleed screw.

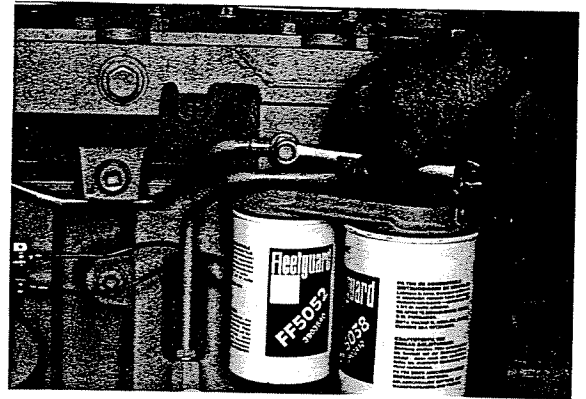

Operate the plunger on the lift pump until the fuel flowing from the fitting is free of air.

Tighten the bleed screw.



Maintenance Required at Each 16,000 KM Page 2-20

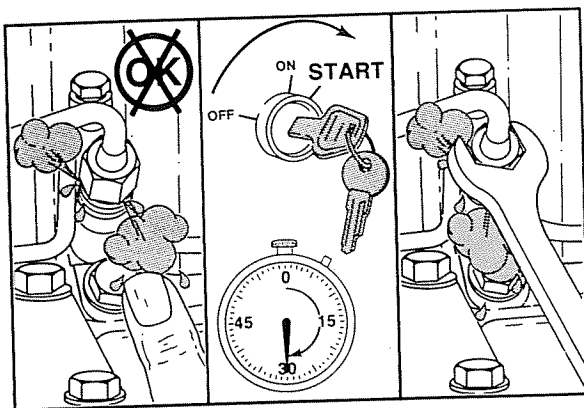

High Pressure Lines - Venting

17 mm

Warning: The pressure of the fuel in the line is sufficient to penetrate the skin and cause serious bodily harm.

Loosen the fittings at the injectors, and crank the engine to allow entrapped air to bleed from the lines. Tighten the fittings.

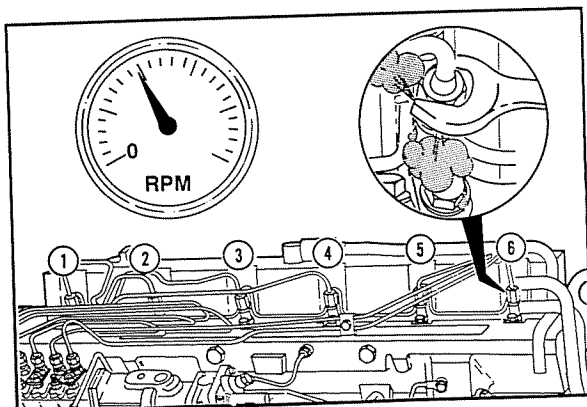

Start the engine and vent one line at a time until the engine runs smoothly.

Antifreeze Concentration - Check

Check the antifreeze concentration. Use ethylene-glycol base antifreeze to protect the engine to -37°C [-34°F] year round.

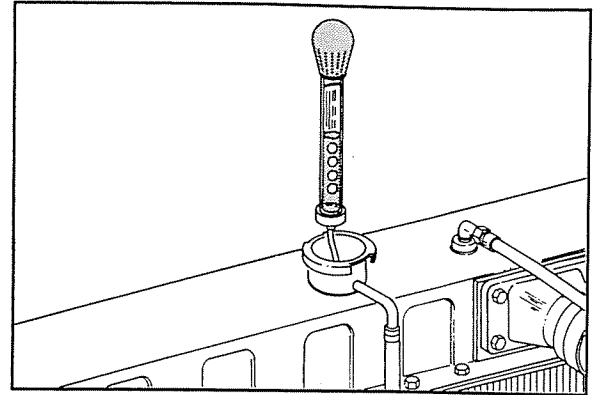

Coolant Additive Concentration - Check

Caution: Inadequate concentration of the coolant additive can result in major corrosive damage to cooling system components. Over concentration can cause formation of "gel" that can cause restriction, plugging of passages, and overheating.



Note: If the engine coolant is changed, the coolant filters must also be changed.

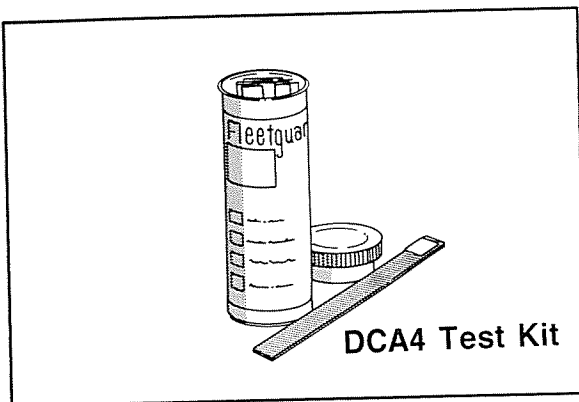

The cooling system must contain the proper coolant additive units to provide the best chemical protection. Refer to the Engine Specifications (Section 5).

DCA4 Test Kit: Use only DCA4 Coolant Test Kit, Fleetguard® Part No. CC-2600 to check the coolant additive concentration in the cooling system.

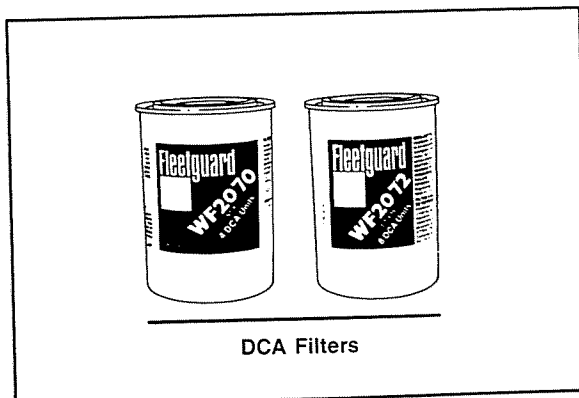

Coolant Filter/DCA4 Corrosion Resistor Cartridge

The correct coolant filter to be used is determined by the total cooling system capacity and other operational factors.



Refer to the DCA4 Maintenance Guide in Engine Specifications (Section 5) for the correct selection of the filter.

Coolant Filter - Replacement

Warning: Do not remove the radiator cap from a hot engine. Hot steam will cause serious personal injury. Remove the coolant system pressure cap and close the shutoff valve before removing the coolant filter. Failure to do so can result in personal injury from heated coolant spray.

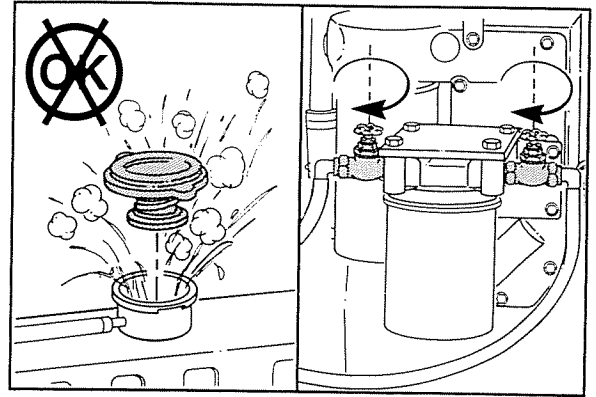

Remove and discard the coolant filter. Clean the gasket surface.

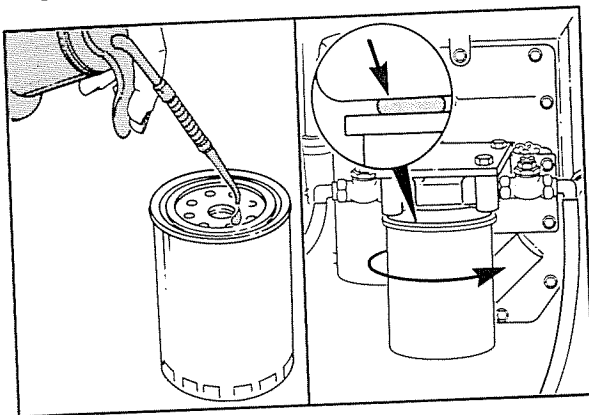
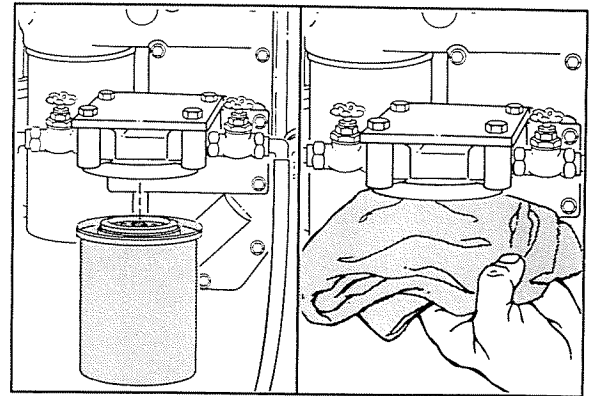

Apply a light film of lubricating oil to the gasket sealing surface before installing the coolant filter.

Caution: Mechanical over-tightening may distort the threads or damage the filter head.

Install the filter as specified by the filter manufacturer.

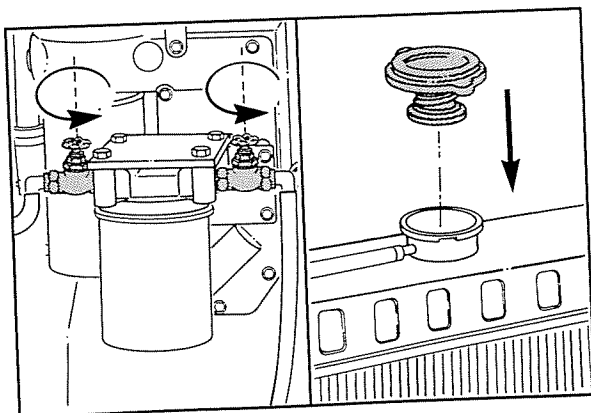

Open the shutoff valve and install the coolant system pressure cap.

Maintenance Required At 33,000 KM [20,000 Miles], 1,000 Hours, or 1 Year Interval

Perform the daily, 16,000 km [10,000 miles], 500 hours or 6 months maintenance and the following.

Valves - Adjustment

Screwdriver

Remove the air crossover tube.

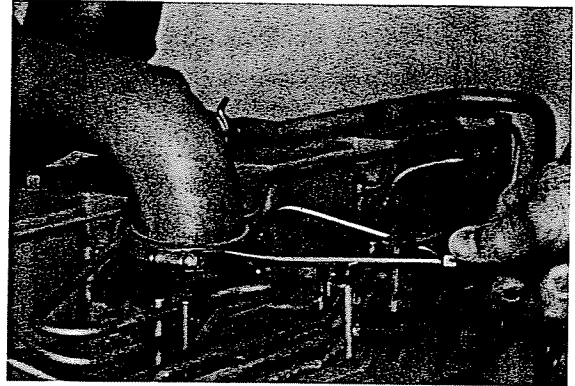

13 and 18 mm

Disconnect the support clamps, hose clamp and remove the crankcase vent tube.

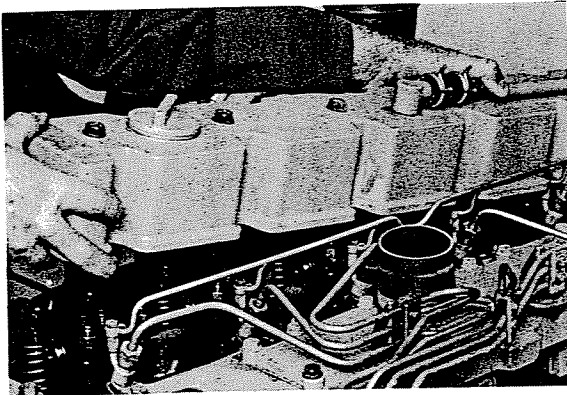
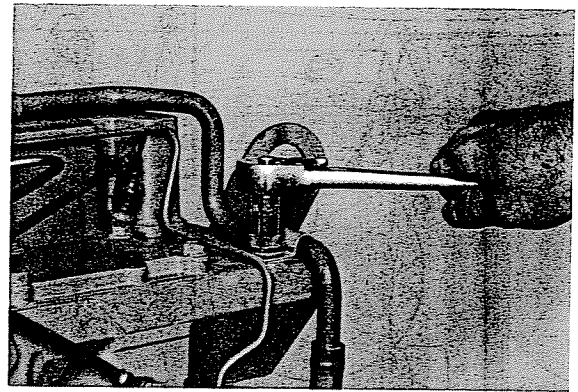

15 mm

Remove the valve cover.

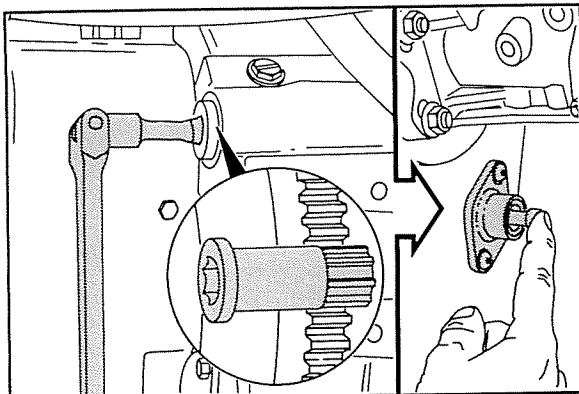

1/2 Inch Drive, 3904682 Barring Gear

Locate Top Dead Center (TDC) for Cylinder Number 1 by barring engine slowly while pressing on the engine timing pin.

When the pin engages the hole in the camshaft gear, Cylinder Number 1 is at TDC on the compression stroke.

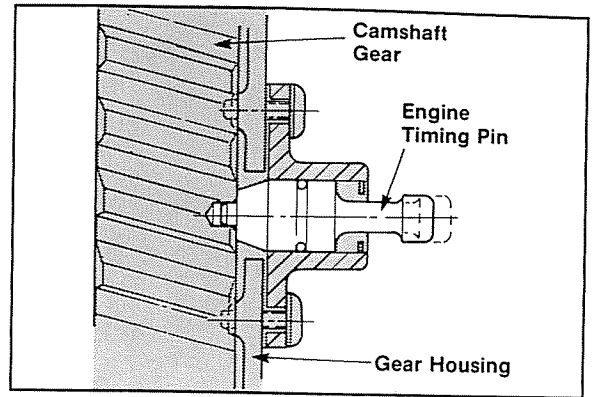

Caution: Be sure to disengage the pin after locating TDC.

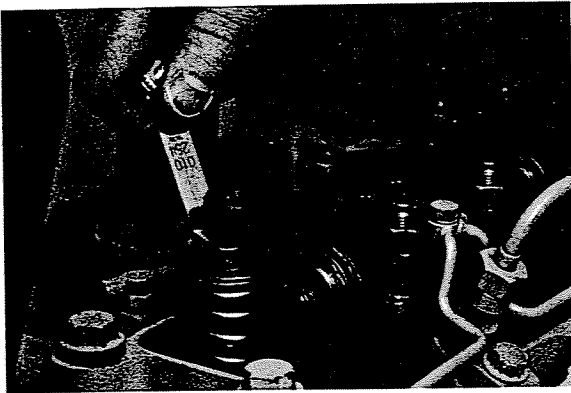
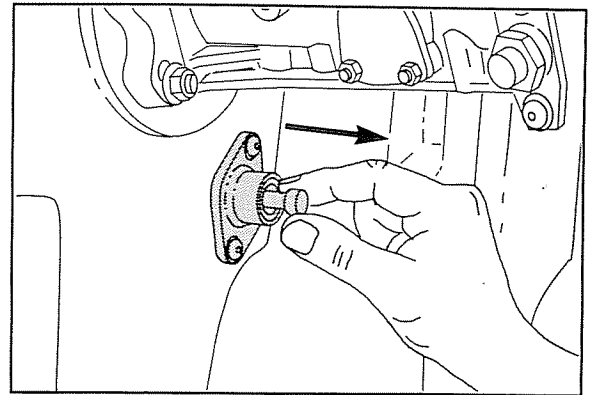

Feeler Gauge

Intake Clearance: 0.30 mm [0.012 inch]

Exhaust Clearance: 0.61 mm [0.024 inch]



Check/set valves with engine cold - below 60° C [140° F].

Note: The clearance is correct when some resistance is "felt" when the feeler gauge is slipped between the valve stem and the rocker lever.



14 mm, Flatblade Screwdriver

Locate Top Dead Center (TDC) for Cylinder Number 1.

Check/adjust the valves indicated for STEP A (I = Intake; E = Exhaust).



Tighten the locknut to 24 N•m [18 ft-lbs] and re-check the valve lash.

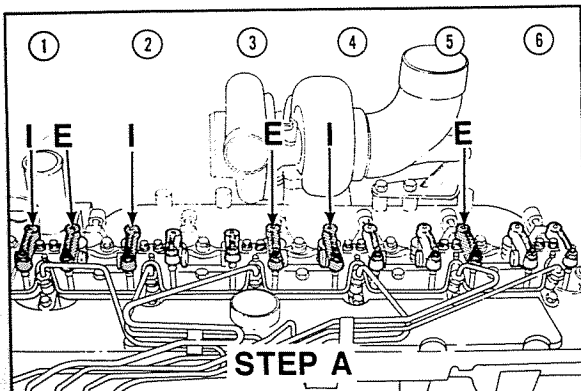

Mark the vibration damper and rotate the crankshaft 360 degrees.

Be sure timing pin is disengaged.

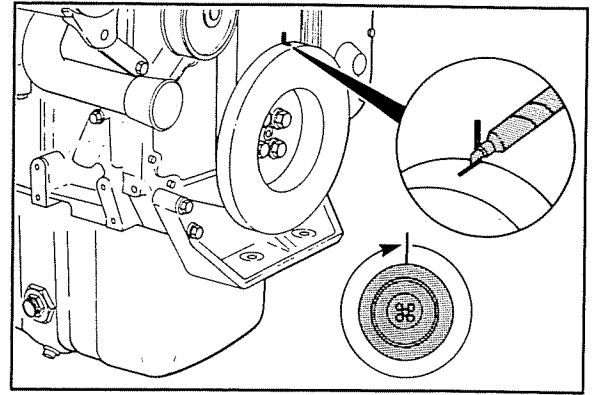

14 mm, Flatblade Screwdriver

Set the valves indicated for STEP B.

Tighten the lock nut to 24 N•m [18 ft-lbs] and recheck the valve lash.

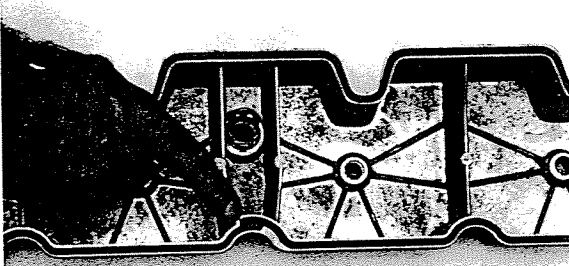
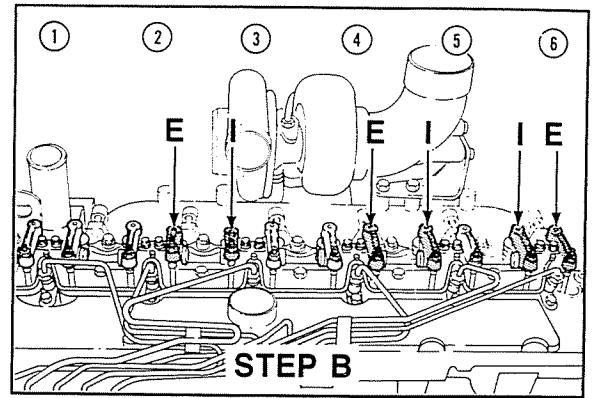

Install the rubber seal into the groove in the valve cover. Start the installation at the overlap area shown in the illustration. Do not stretch the rubber seal.

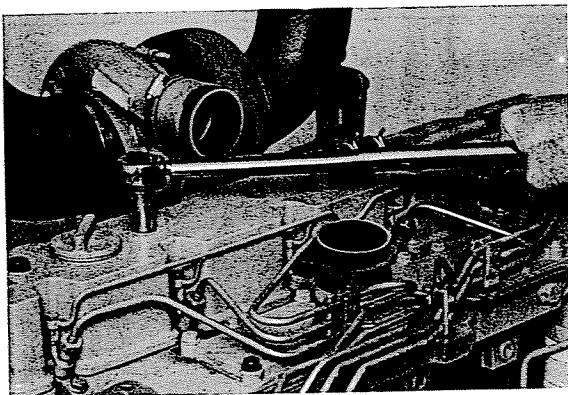

15 mm

Install the valve cover.

Torque Value: 24 N•m [18 ft-lb].

13 and 18 mm

Install the crankcase vent tube and secure with the support clamps and hose clamp.

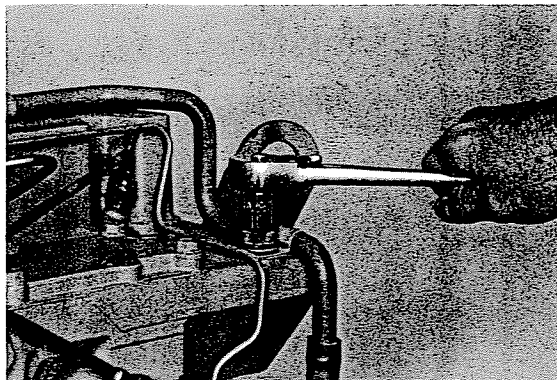

Screwdriver

Install the air crossover tube.

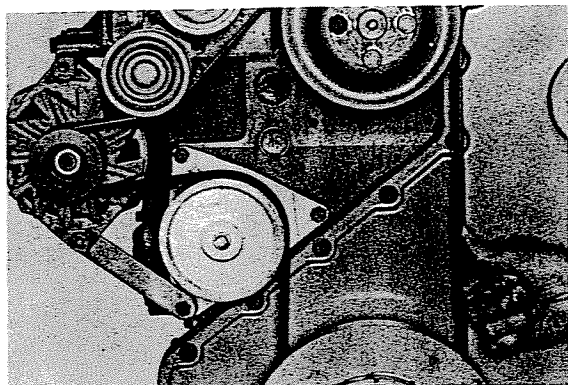
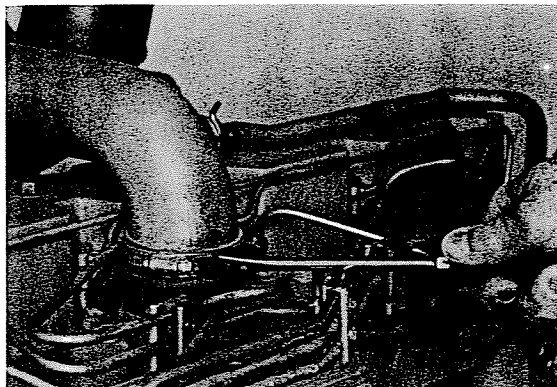

Drive Belt Tension - Check

Measure the belt deflection at the longest span of the belt.
Maximum Deflection: 9.5 to 12.7mm [3/8 to 1/2 inch]

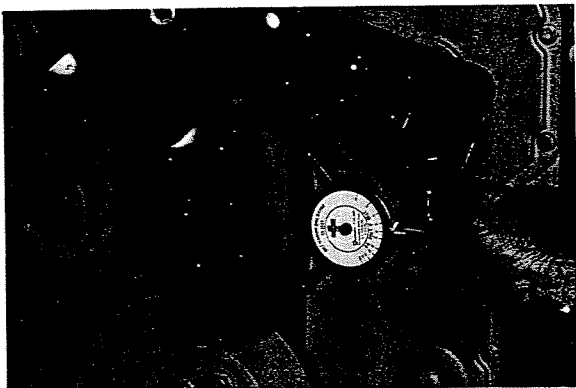

Note: The Cummins belt tension gauge ST-1293 can be used. The required gauge value is 80 to 110 lbs.

Drive Belt, Tensioner Bearing and Fan Hub - Inspection

Wrench Size: 1/2 Inch Square Drive

Remove the drive belt and complete the following steps:

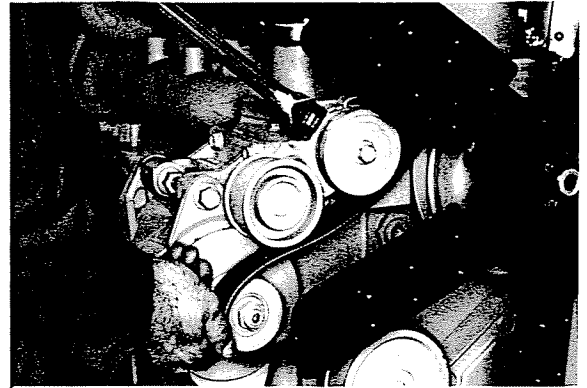

- Inspect the belt for damage.

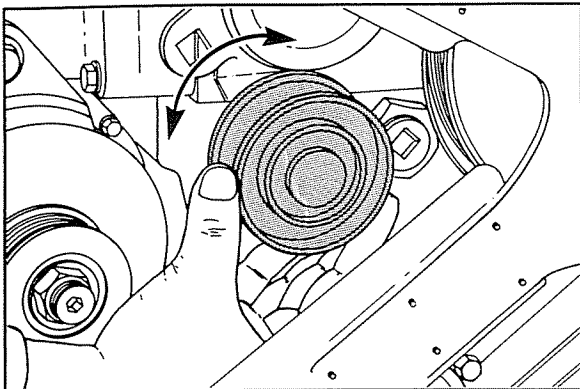
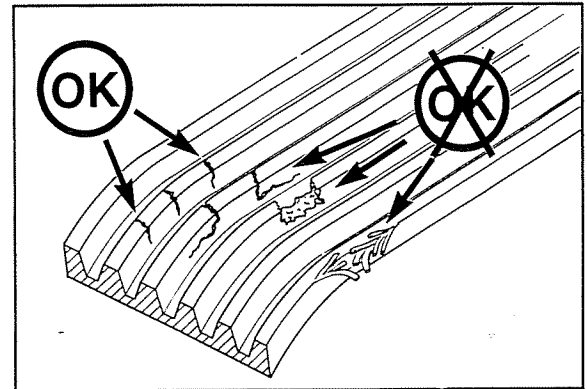

Note: The tensioner pulley should spin freely with no rough spots detected under hand pressure.

- Check the tensioner bearing.

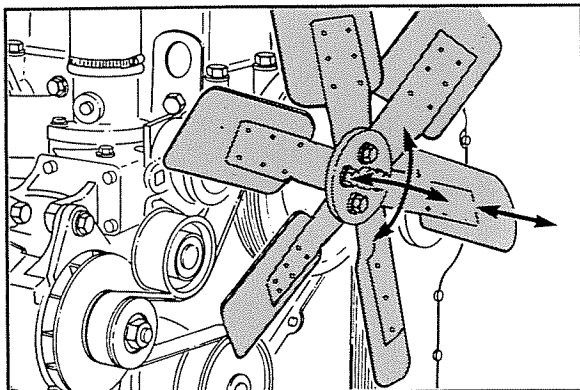

Note: The fan hub should spin freely without any wobble or excessive end play.

- Check the fan hub bearing.

Maximum End Play
0.15 mm [0.006 in.]

1/2 Inch Square Drive

Install the drive belt.

Service Tip: If difficulty is experienced installing the drive belt (the belt seems too short), position the belt over the grooved pulleys first and then, while holding the tensioner up, slide the belt over the water pump pulley.

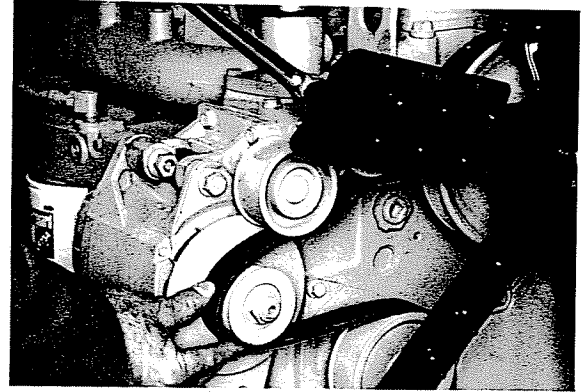

Maintenance Required At Every 64,000 KM [40,000 Miles], 2,000 Hours Or 2 Years Interval

Perform the 33,000 km [20,000 miles], 1,000 hours or 1 year maintenance and the following.

Coolant Change and Flushing the System

Warning: Wait until the temperature is below 50° C [120° F] before removing the coolant system pressure cap. Failure to do so can cause personal injury from heated coolant spray.

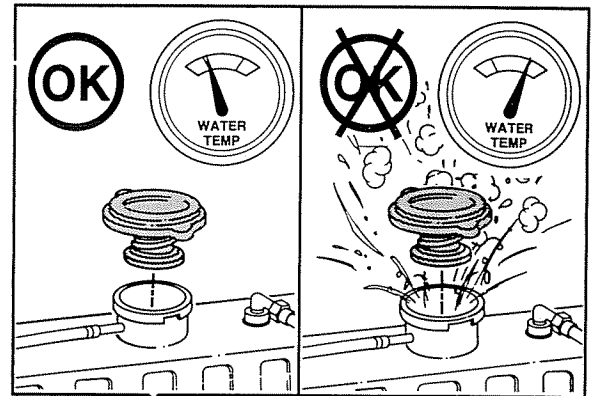

Maintenance Required At Every 64,000 KM Page 2-36

Maintenance Guidelines C Series

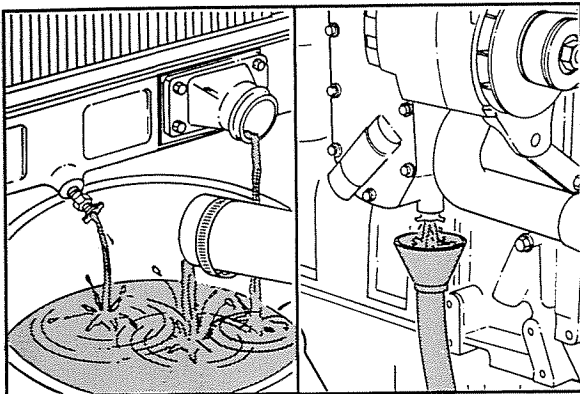

Drain the cooling system by opening the drain valve on the radiator and oil cooler. A drain pan with a capacity of 20 litres [5 U.S. gallons] will be adequate in most applications.

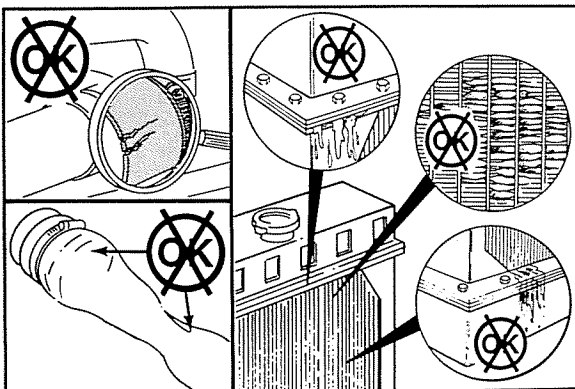

Check for damaged hoses and loose or damaged hose clamps. Replace as required. Check the radiator for leaks, damage and build up of dirt. Clean and repair as required.

**Maintenance Guidelines
C Series**

**Maintenance Required At Every 64,000 KM
Page 2-37**

Caution: During filling, air must be vented from the engine coolant passages. Open the engine venting petcock and, the petcock on the aftercooler for aftercooled engines.

Adequate venting is provided for a fill rate of 38 litres/minute [10 U.S. gallon/minute].

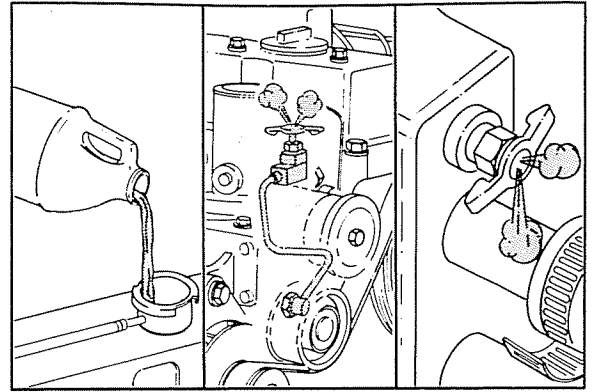

Fill the system with a mixture of sodium carbonate and water (or a commercially available equivalent).

Note: Use 0.5 kilogram [1.0 pound] of sodium carbonate for every 23 litres [6.0 U.S. gallons] of water.

Caution: Do not install the radiator cap.

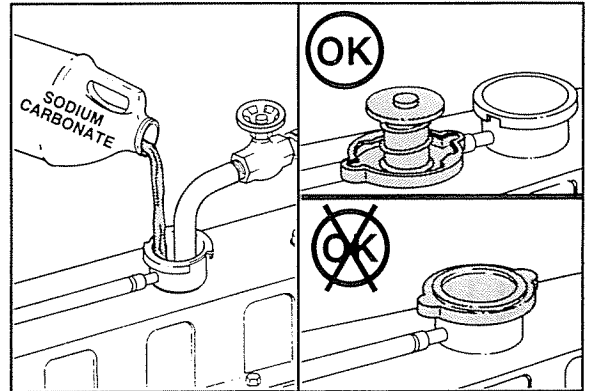

**Maintenance Required At Every 64,000 KM
Page 2-38**

**Maintenance Guidelines
C Series**

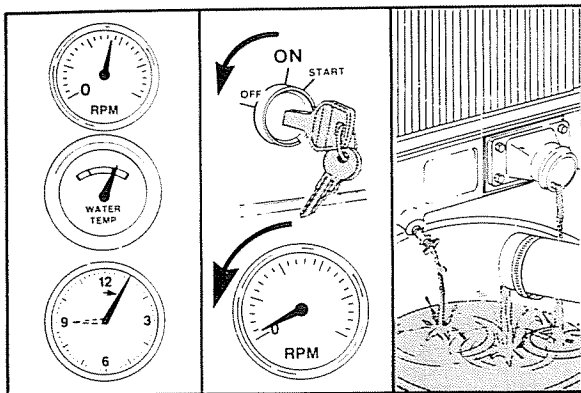

Operate the engine for 5 minutes with the coolant temperature above 80° C [180° F].

Shut the engine off, and drain the cooling system.

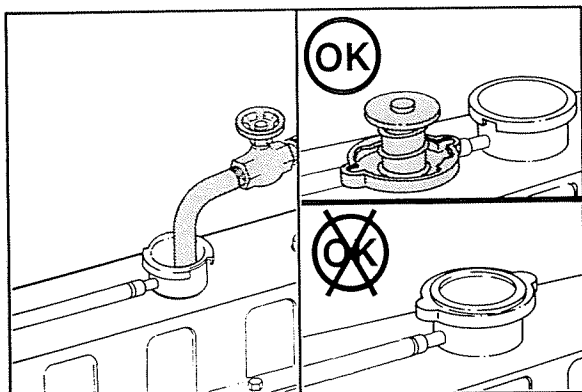

Fill the cooling system with clean water.

Note: Be sure to vent the engine and aftercooler for complete filling.

Caution: Do not install the radiator cap or the new coolant filter.

**Maintenance Guidelines
C Series**

**Maintenance Required At Every 64,000 KM
Page 2-39**

Operate the engine for 5 minutes with the coolant temperature above 80° C [180° F].

Shut the engine off, and drain the cooling system.

Note: If the water being drained is still dirty, the system must be flushed again until the water is clean.

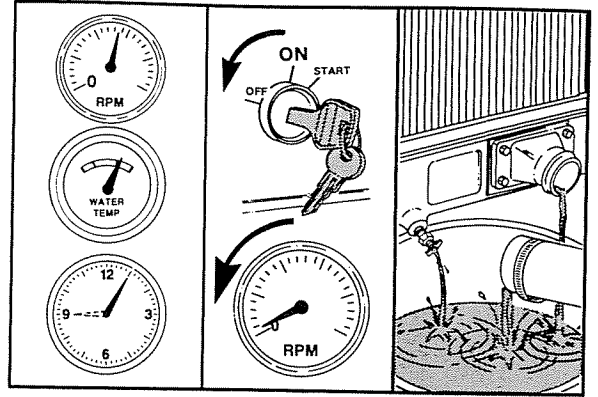

Use a mixture of 50 percent water and 50 percent ethylene glycol antifreeze to fill the cooling system.

Coolant Capacity (Engine Only)		Litre [U.S. Quarts]
6C8.3	6CTA8.3	6CT8.3
11.4 [12.0]	11.4 [12.0]	12.3 [13.0]

Note: Use the correct amount of DCA4 corrosion inhibitor to protect the cooling system. Refer to Section 5.

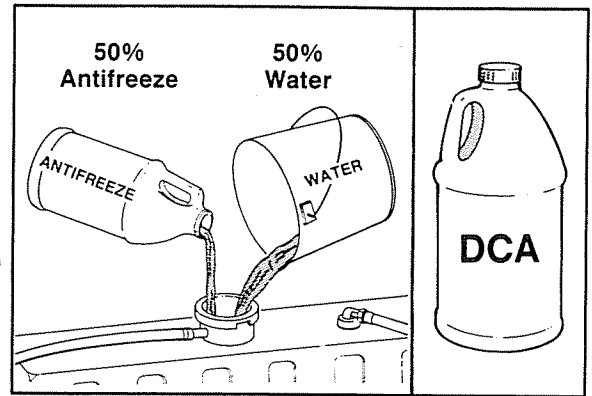

**Maintenance Required At Every 64,000 KM
Page 2-40**

**Maintenance Guidelines
C Series**

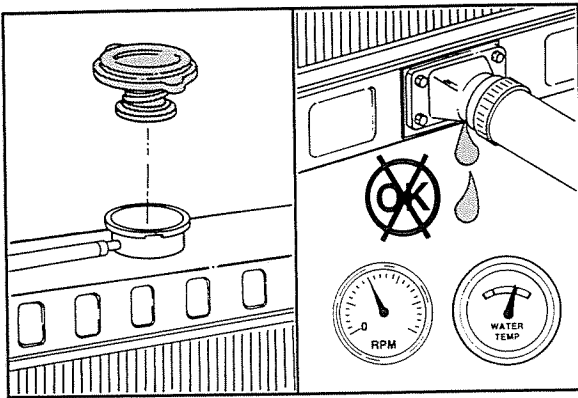

Install the pressure cap. Operate the engine until it reaches a temperature of 80° C [180° F], and check for coolant leaks.

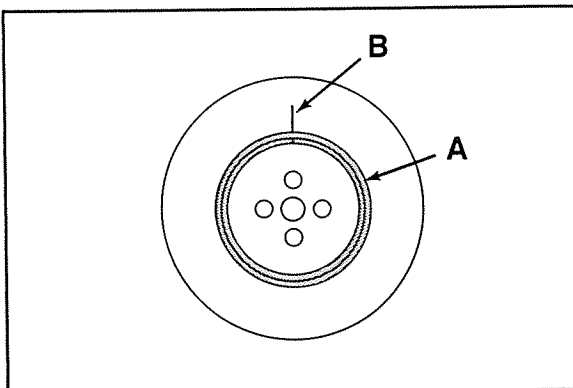

Vibration Damper - Inspection

Check the index lines (B) on the damper hub and the inertia member(A). If the lines are more than 1.59 mm [1/16 inch] out of alignment, replace the damper.

Inspect the rubber member for deterioration. If pieces of rubber are missing or if the elastic member is more than 3.18 mm [1/8 inch] below the metal surface, replace the damper.

Note: Also look for forward movement of the damper ring on the hub. Replace the damper if any movement is detected.

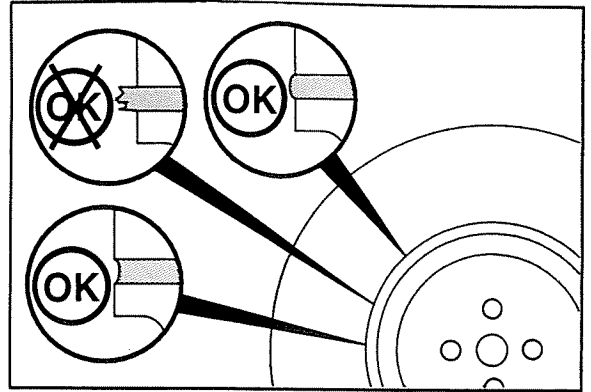

Air Compressor - Inspection

Note: All air compressors have a small amount of oil carryover which lubricates the piston rings and moving parts. When this oil is exposed to normal air compressor operating temperatures over a period of time, it will form varnish or carbon deposits. If the following inspections are not done, the air compressor piston rings will be affected by high operating temperatures and pressures and will not seal correctly.

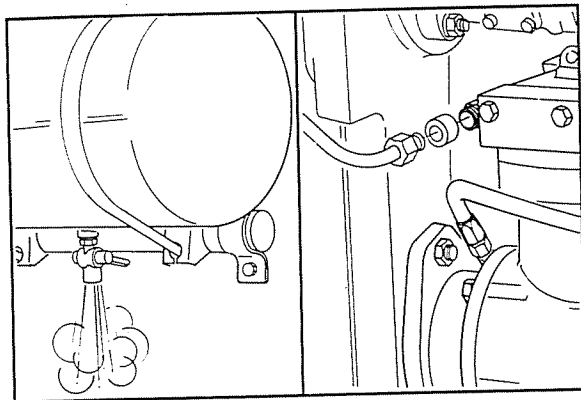
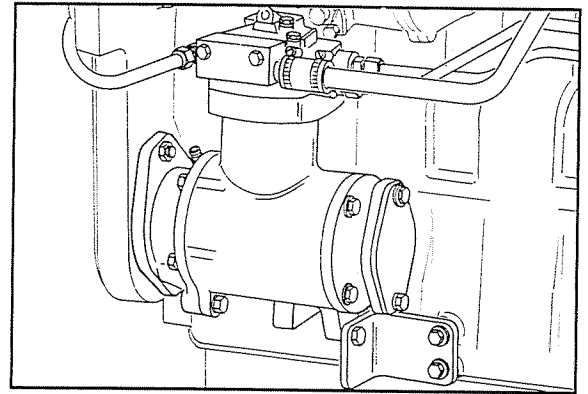

Air Compressor Discharge - Inspection

Drain the air system wet tank to release the system air pressure. Remove the air discharge line from the air compressor.

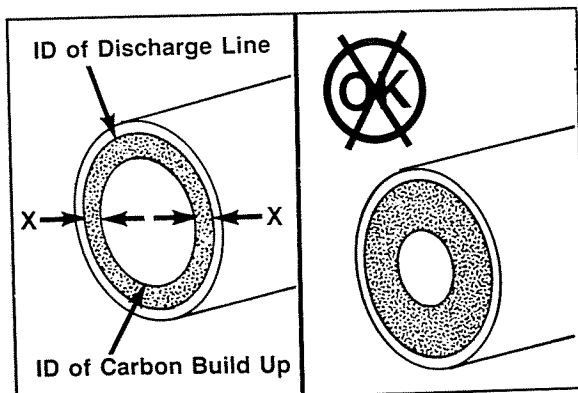

Measure the total carbon deposit thickness inside the air discharge line as shown. If the total carbon deposit (X + X) exceeds 2 mm [1/16-inch], clean and inspect the cylinder head, the valve assembly, and the discharge line. Replace if necessary. Contact your Cummins authorized repair location for procedures.

If the total carbon deposit exceeds specifications, continue checking the air discharge line connections up to the first tank until total carbon deposit is less than 2 mm [1/16-inch]. Clean or replace any lines or connections that exceed this specification.

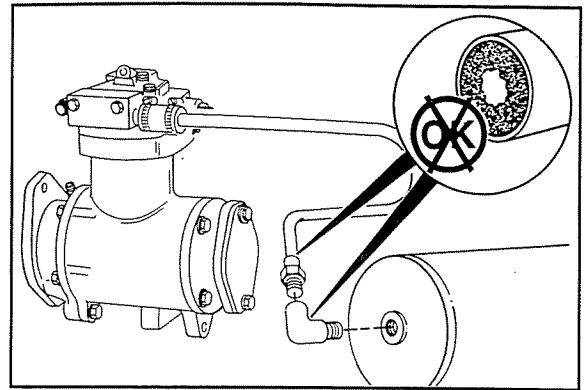

Inspect any air driers, spitter valves, pressure relief valves, and alcohol injectors for carbon deposits or malfunctioning parts. Inspect for air leaks. Maintain and repair the parts according to the manufacturer's specifications.

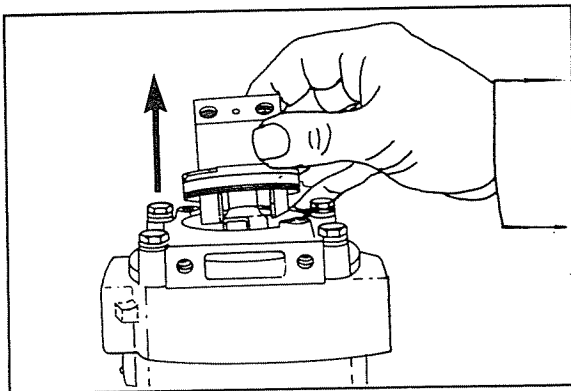
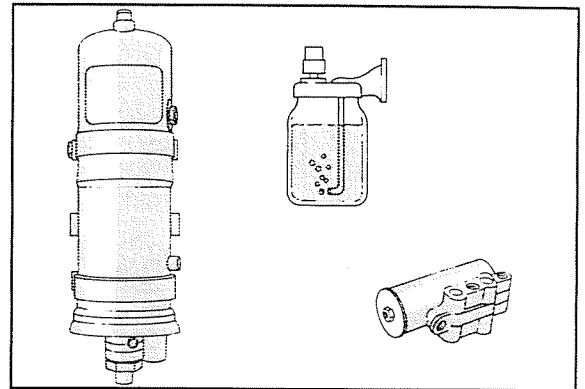

Air Compressor Intake - Inspection



Warning: Hold the unloader valve down when removing the capscrews. Personal injury can result from the sudden release of the spring-loaded unloader valve.

Remove the capscrews, the lock washers, and the flat washers that secure the unloader valve assembly to the cylinder head cover. Remove the unloader valve assembly and the spring from the cylinder head and the cover.

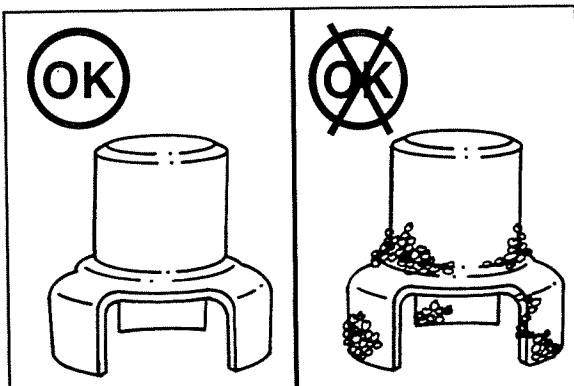

Visually inspect the unloader valve for carbon buildup. If carbon or heavy varnish is present, remove, clean, and inspect the compressor head and the valve assembly. Replace parts as necessary. Contact your nearest authorized repair location for procedures.

Note: The open side of the rectangular seal must face the top of the unloader body.

If the unloader valve is clean or only lightly varnished, install a new O-ring on the unloader body and a new rectangular seal inside the unloader body cavity.

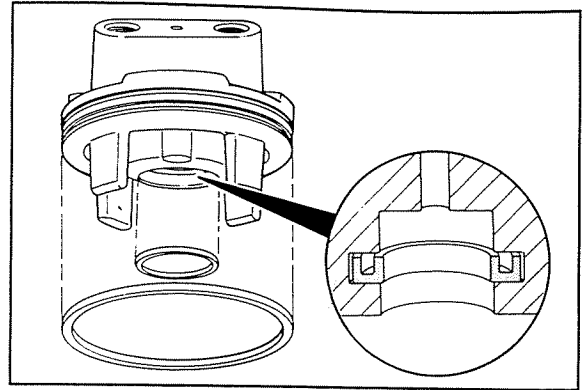

Lubricate the unloader cap with anti-seize compound. Lubricate the unloader body O-ring with engine oil. Assemble the unloader assembly to the cylinder head cover. Tighten the capscrews to 14 N•m [10 ft-lbs] torque.

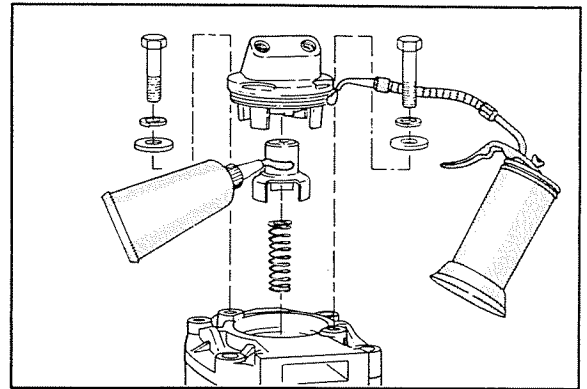

Section 3 - Troubleshooting

Table of Contents

Subject	Page
Troubleshooting Guide for the Operator.....	3-11
Symptoms List.....	3-12
Probable Cause and Recommended Correction Charts	3-13
Engine Systems Diagrams.....	3-2

Troubleshooting

Engine System Diagrams

The following drawings show the flow through the engine systems. Although parts can change between different applications and installations, the flow remains the same. The systems shown are:

- Lubrication
- Coolant
- Air
- Fuel

Knowledge of the engine systems can help you in troubleshooting, service and general maintenance of your engine.

Lubricating Oil System

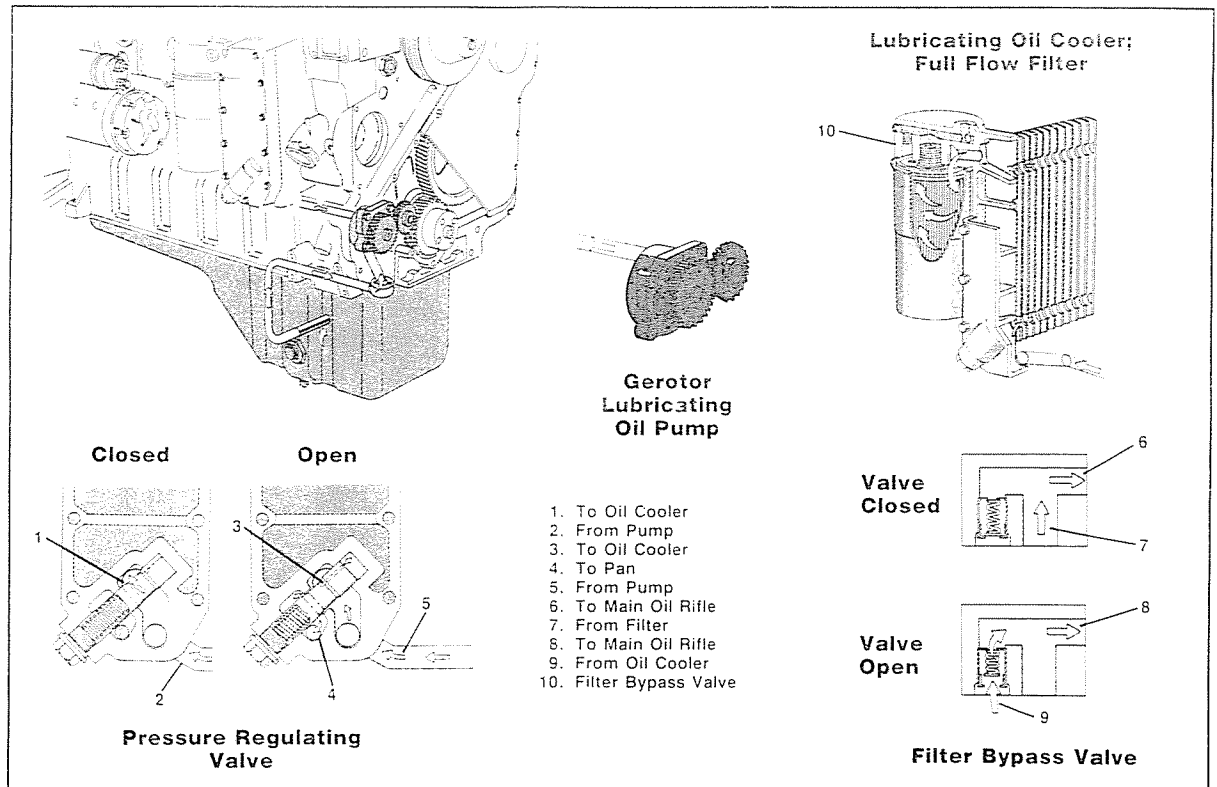

Lubrication for the Turbocharger

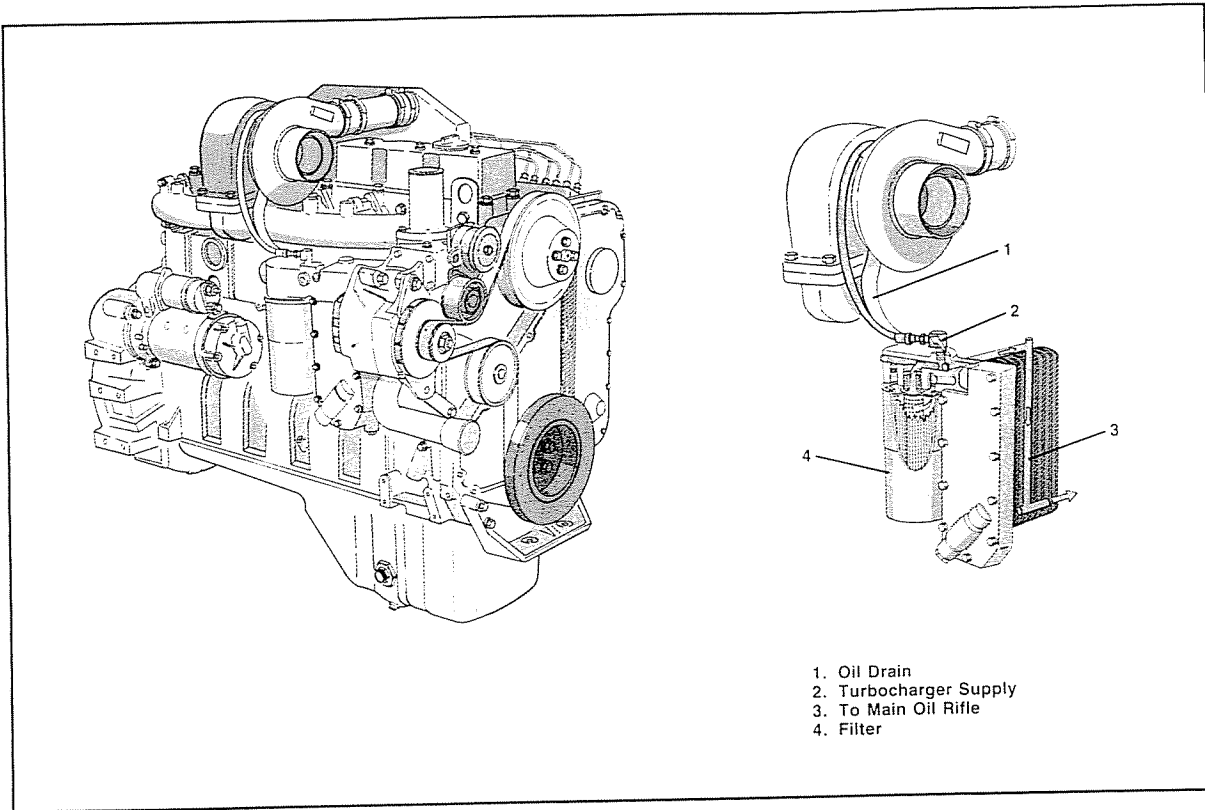

Lubrication for the Power Components

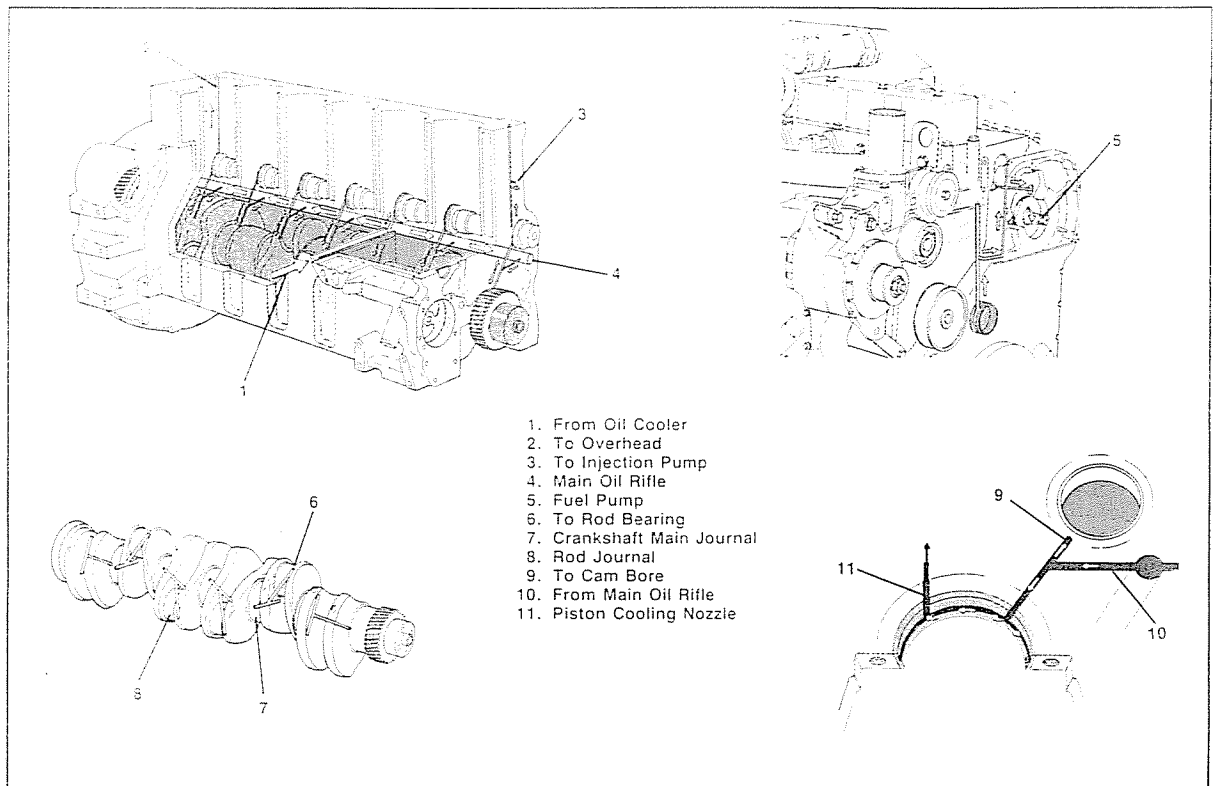

Lubrication for the Overhead

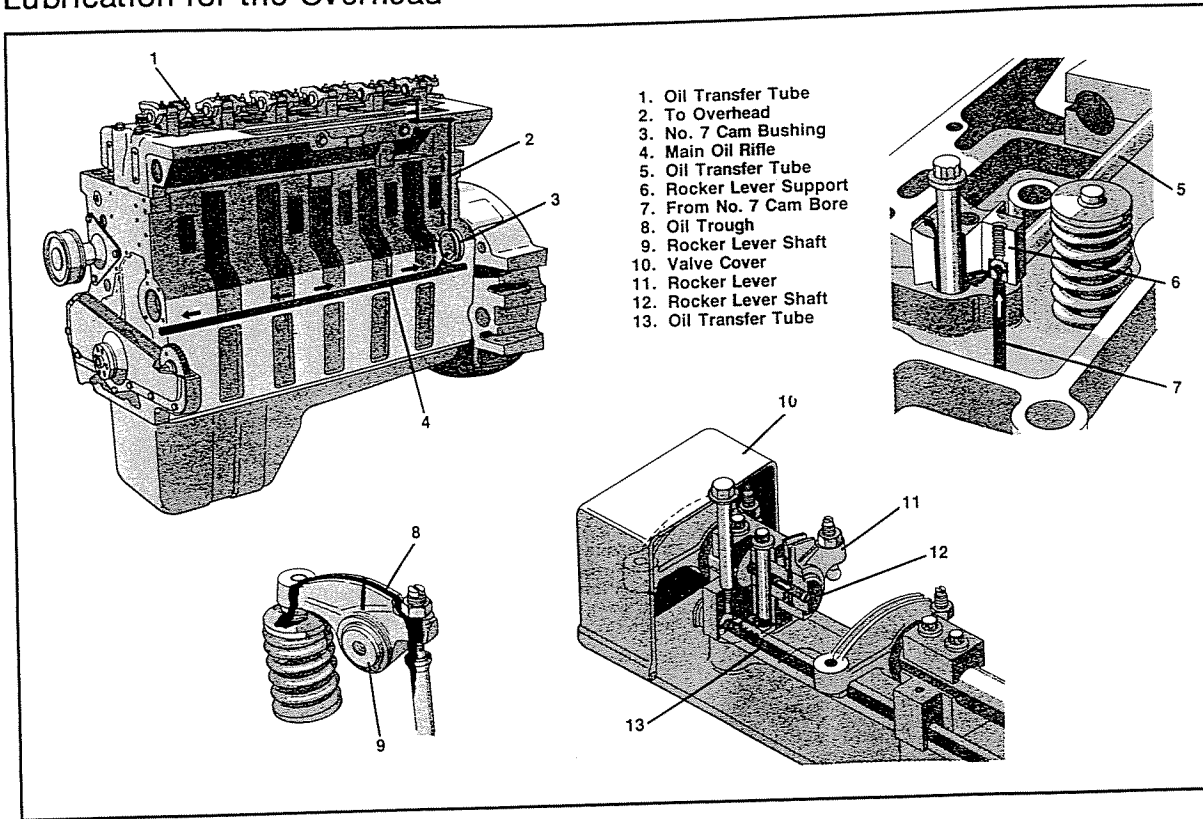

Coolant System

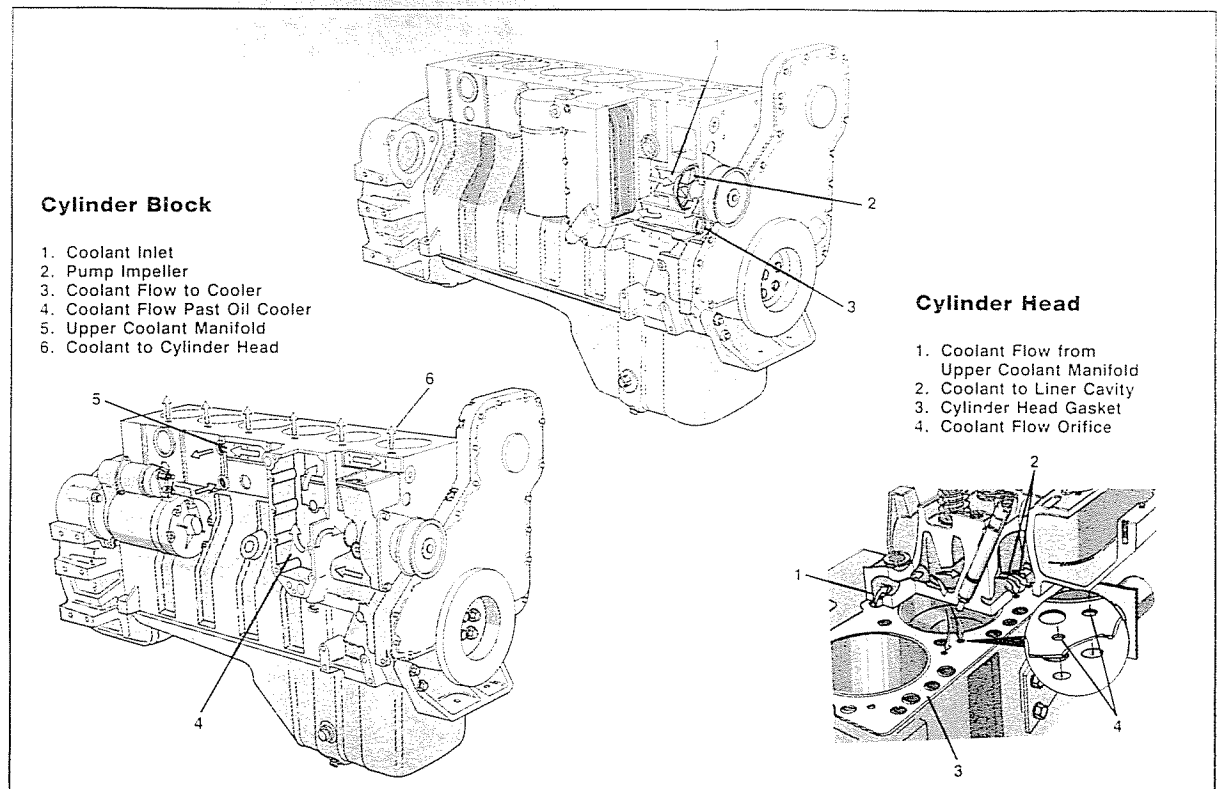

Coolant System

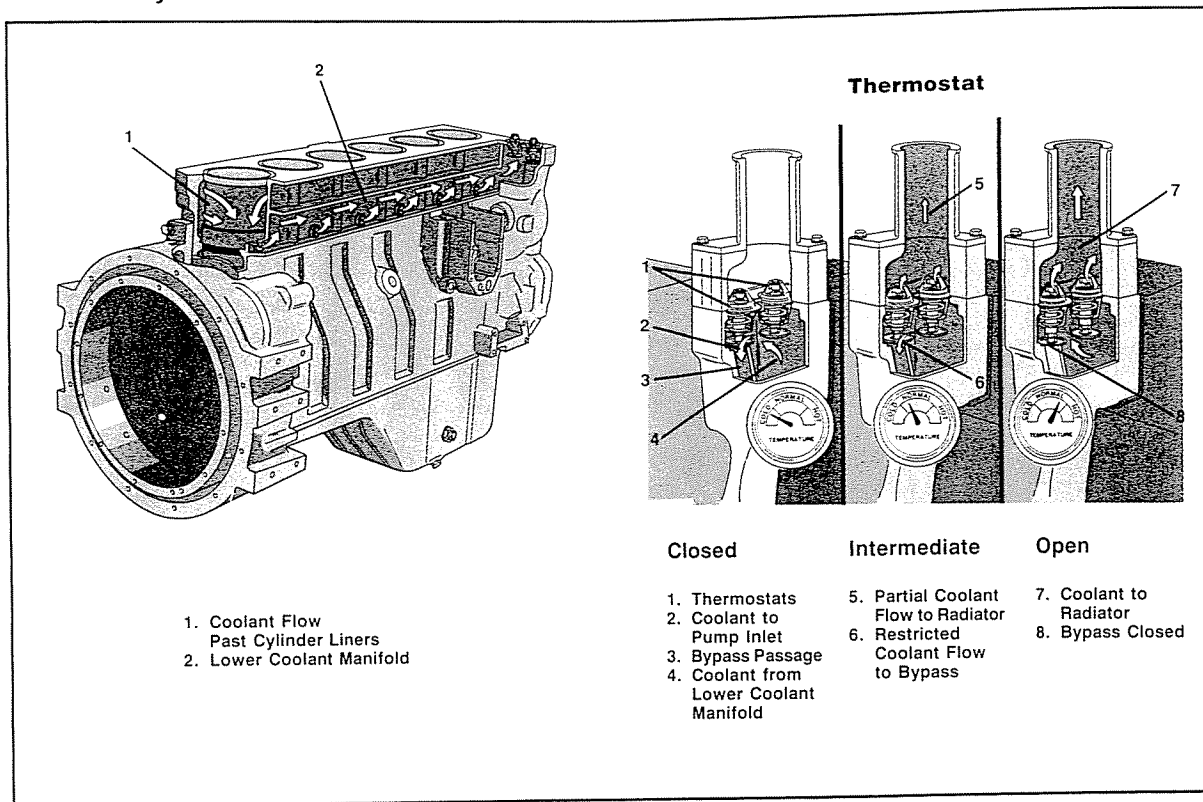

Air System

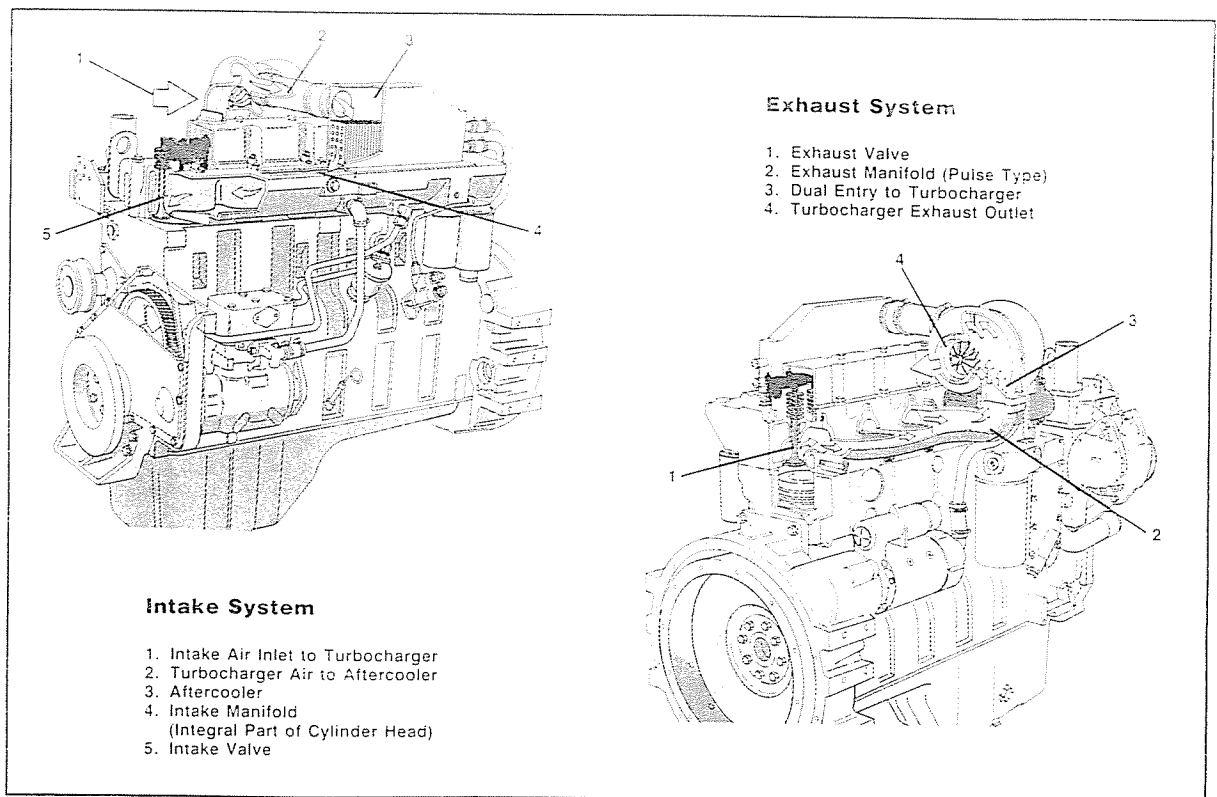

Fuel System

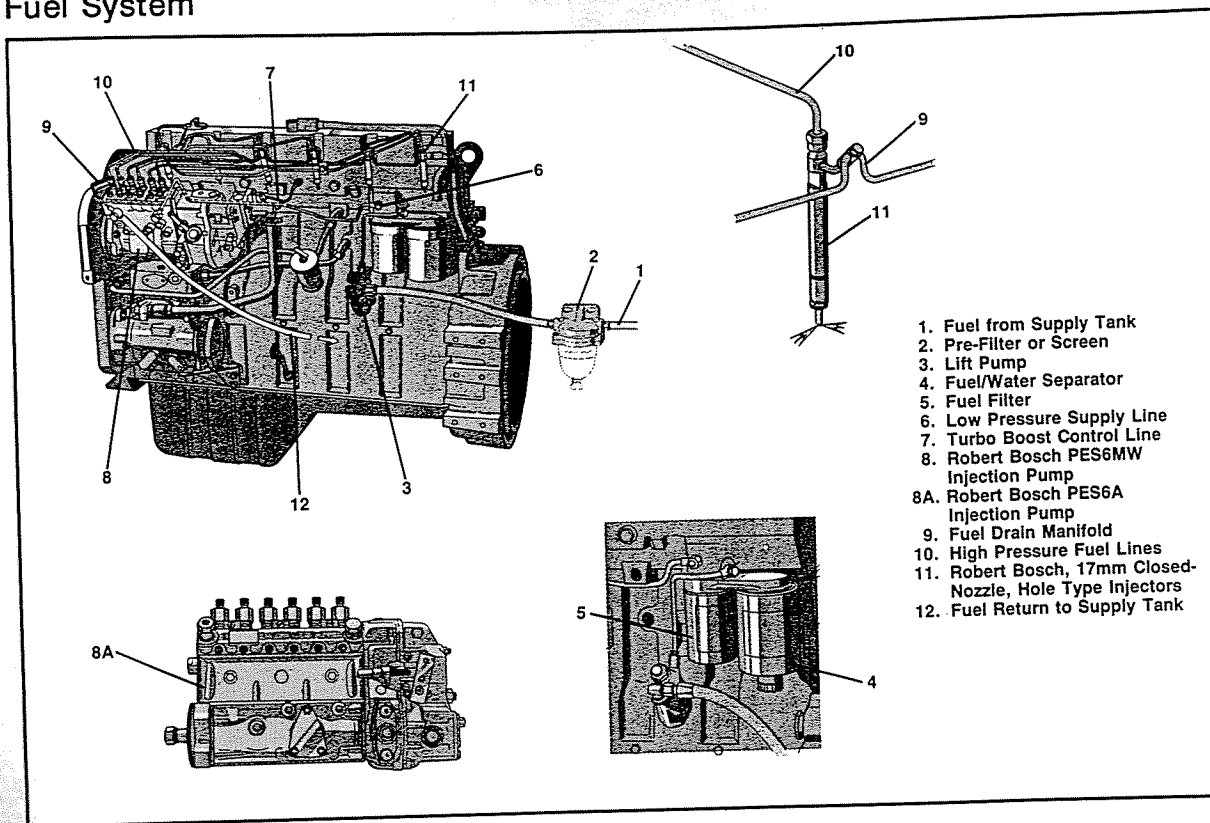

Troubleshooting Guide For The Operator

This guide describes some typical engine operating problems, their causes, and some acceptable corrections to those problems. Unless noted otherwise, the problems listed are those which an operator can diagnose and repair. See a Cummins authorized repair location for diagnosis and repair of problems not listed.

Follow the suggestions below to develop good troubleshooting procedures:

- Study the problem thoroughly before acting.
- Do the easiest and obvious things first.
- Find and correct the basic cause of the problem.

Troubleshooting Charts

Refer to Page No.

Symptoms List

- Alternator not charging or insufficient charging3-39
- Contaminated lube oil3-28
- Contaminated coolant3-27
- Coolant loss3-25
- Coolant temperature above normal3-23
- Coolant temperature below normal3-26
- Engine cranks, but will not start (no smoke from exhaust)3-15
- Engine hard to start, or will not start (exhaust smoke present)3-14
- Engine misfiring3-34
- Engine starts, but will not keep running3-16
- Engine surges at idle3-19
- Engine surges at idle3-13
- Engine will not crank or cranks slowly3-31
- Engine will not reach rated speed when loaded3-17
- Engine will not shut off3-38
- Excessive engine noises3-36
- Excessive fuel consumption3-37
- Excessive vibration3-30
- Exhaust smoke excessive under load3-35
- Fuel knock3-29
- Fuel or oil leaking from exhaust manifold3-32
- Low power3-22
- Lube oil loss3-20
- Lubricating oil pressure low3-21
- Lubricating oil pressure too high3-18
- Rough idle, warm engine3-18

Read each row of blocks from top to bottom. Follow the arrows through the chart to identify corrective action.

Troubleshooting
C Series

Troubleshooting Charts
Page 3-13

Engine Will Not Crank or Cranks Slowly

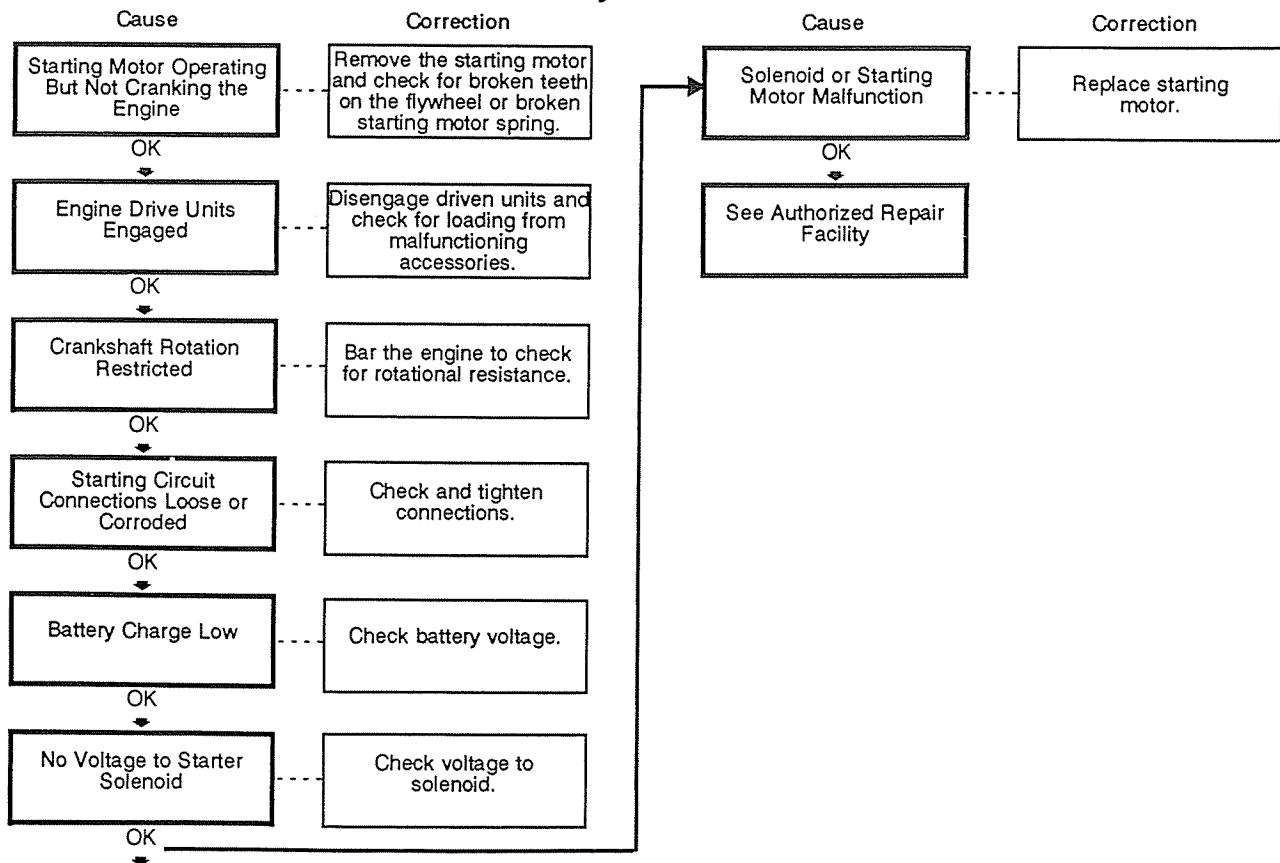

Engine Starts But Will Not Keep Running

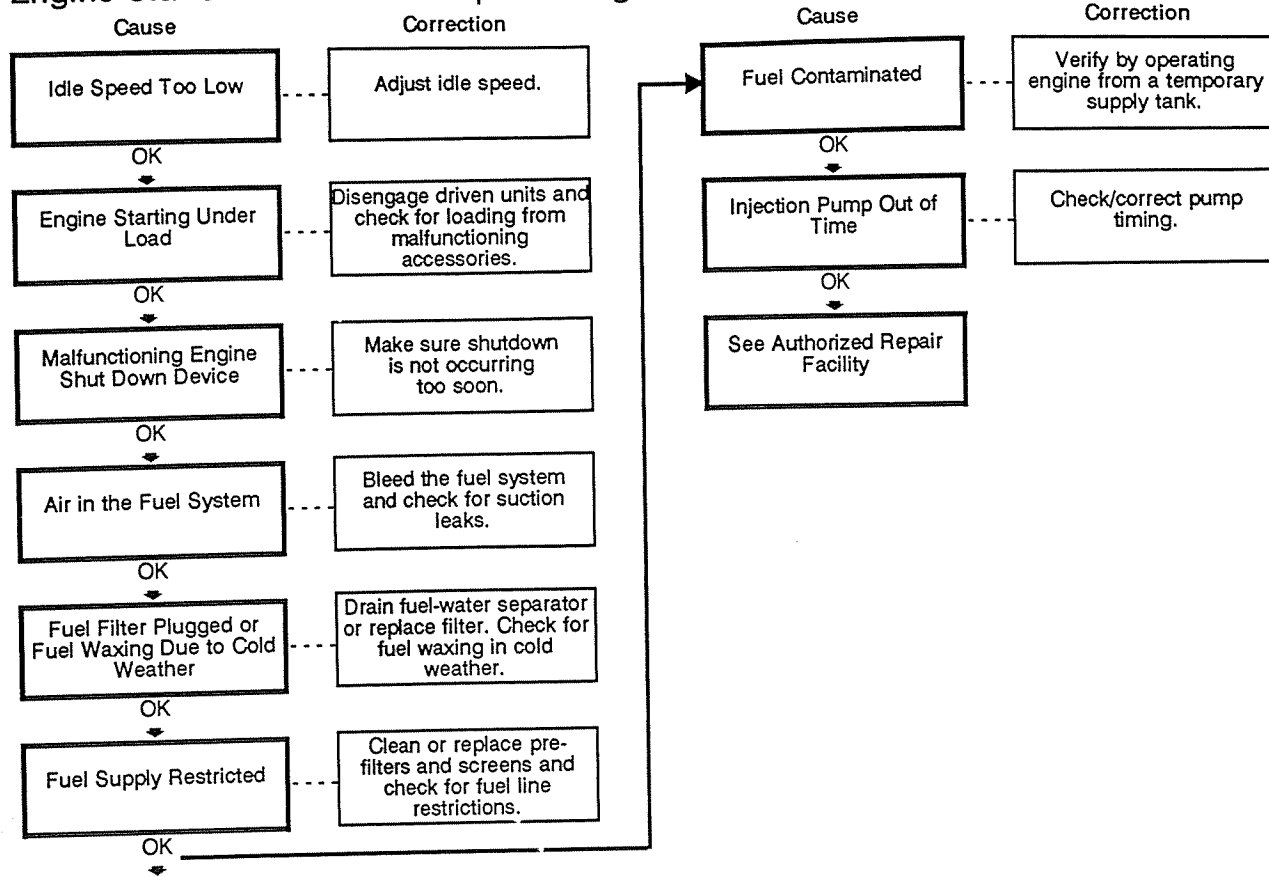

Engine Will Not Shut Off

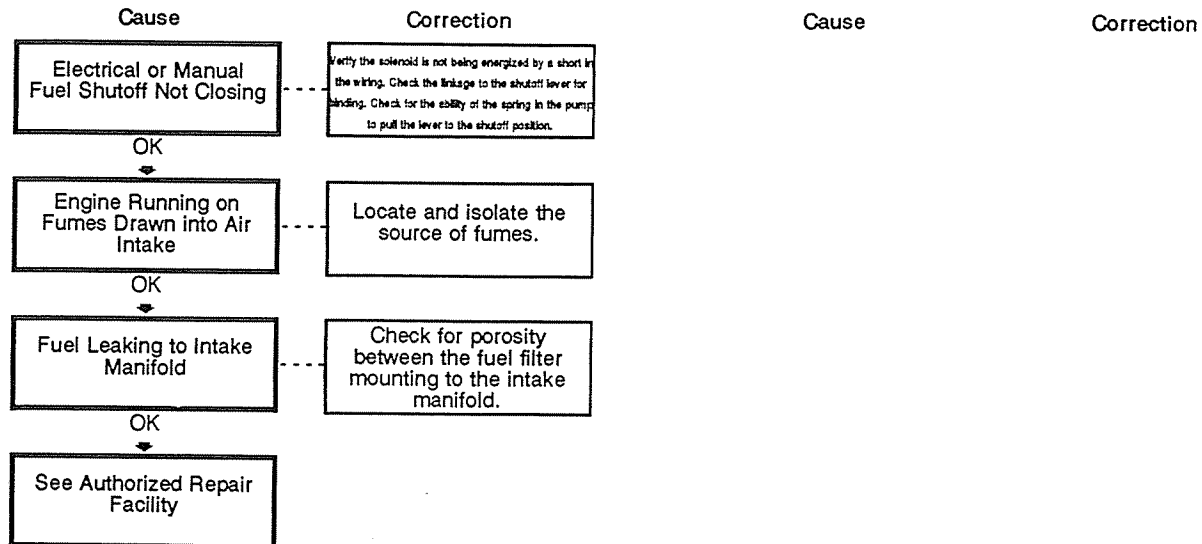

Rough Idle, Warm Engine

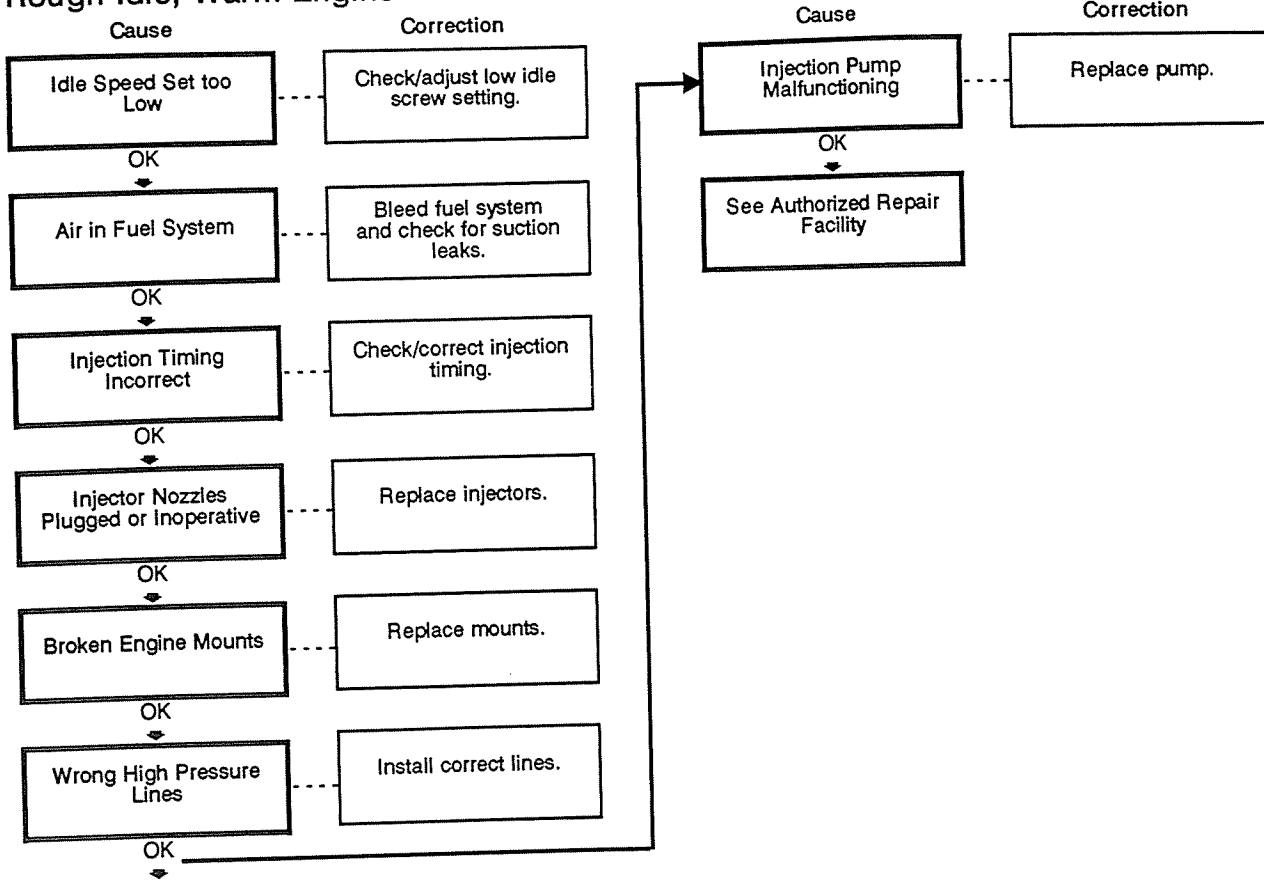

Troubleshooting C Series

Engine Surges at Idle

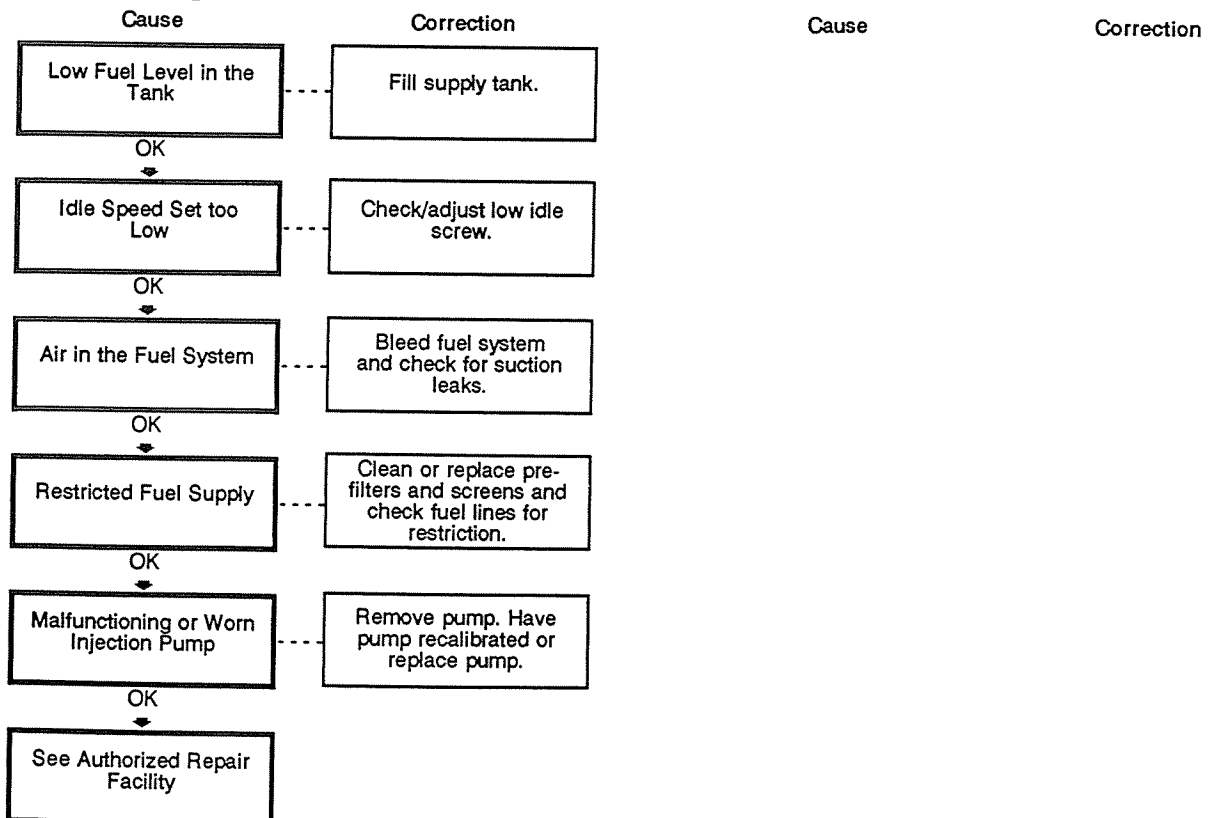

Lubricating Oil Pressure Low

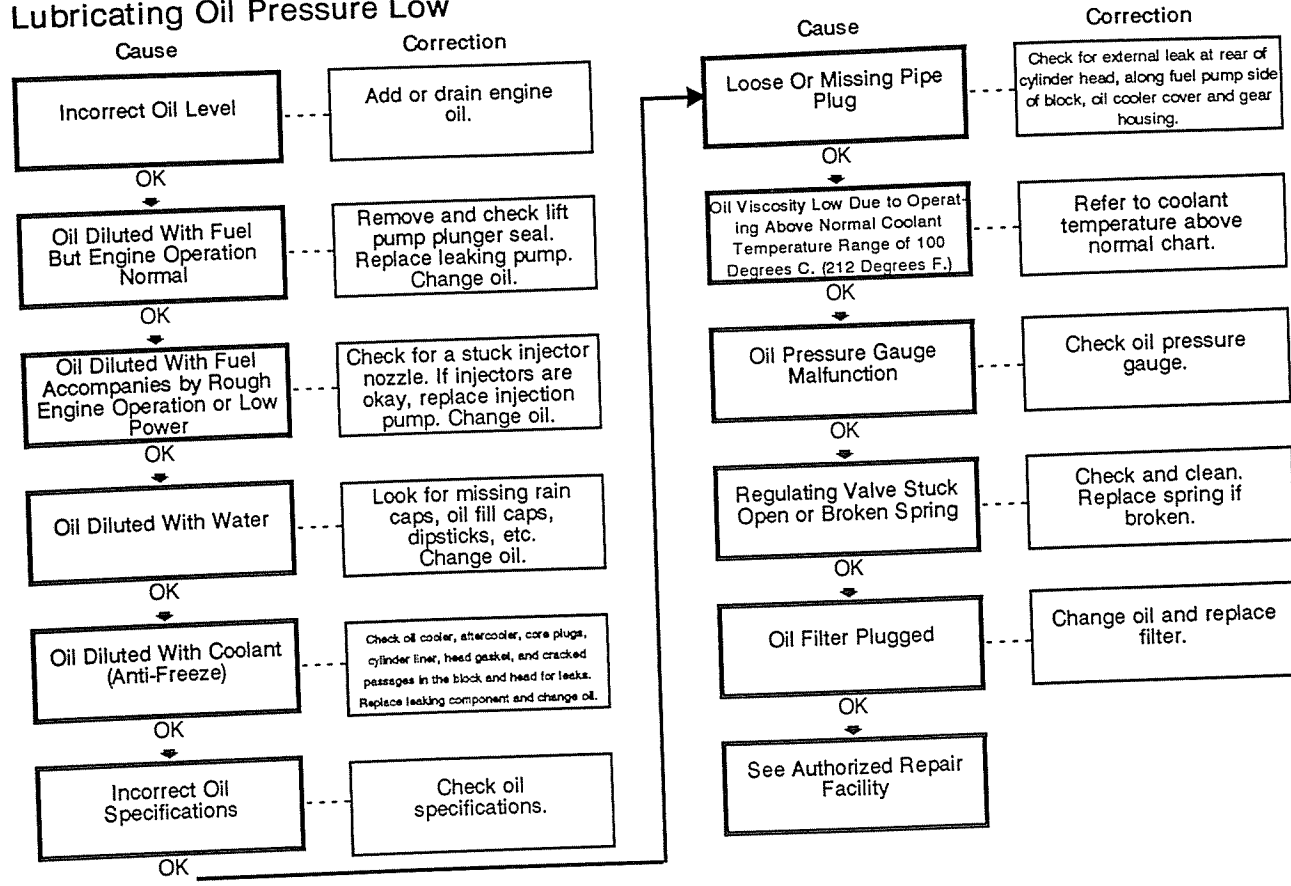

Lubricating Oil Pressure Too High

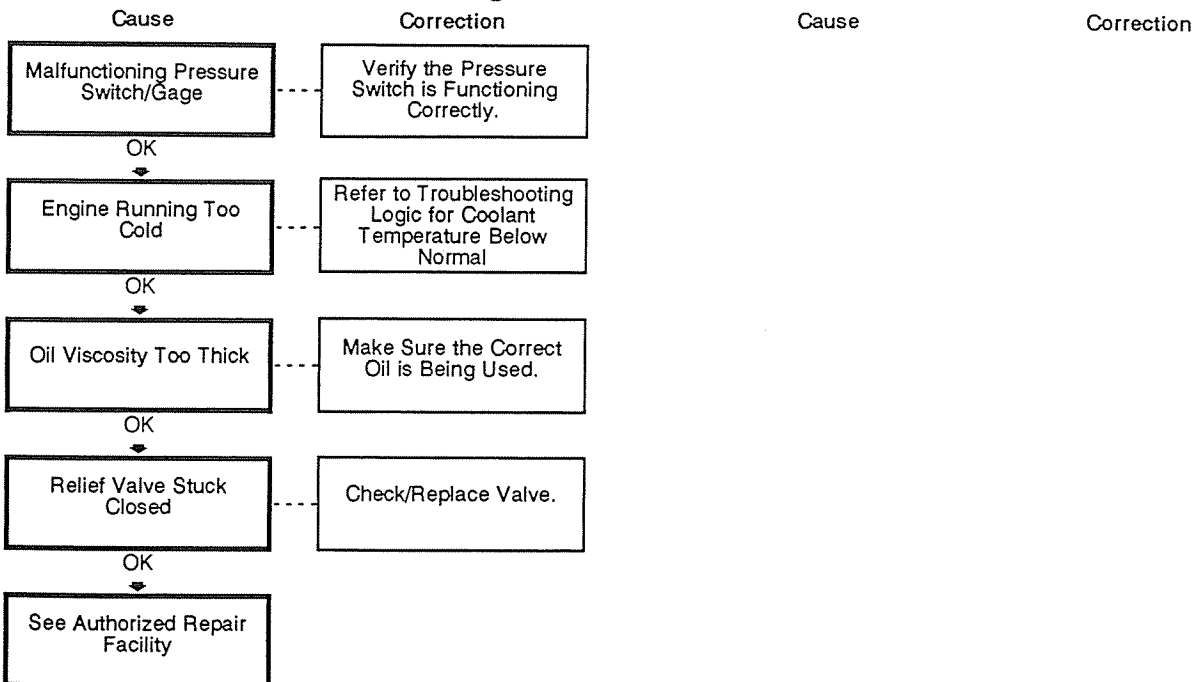

Lube Oil Loss

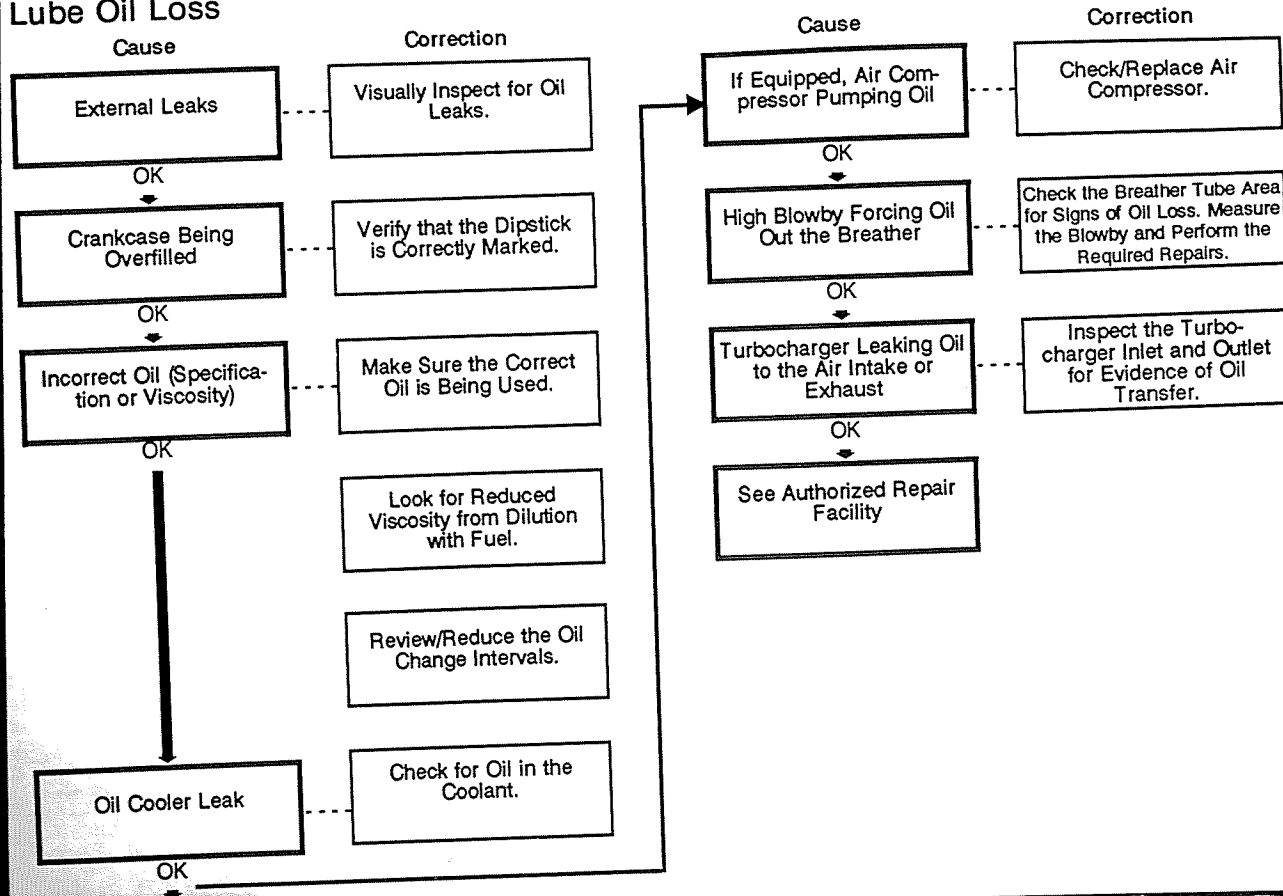

Coolant Temperature Above Normal

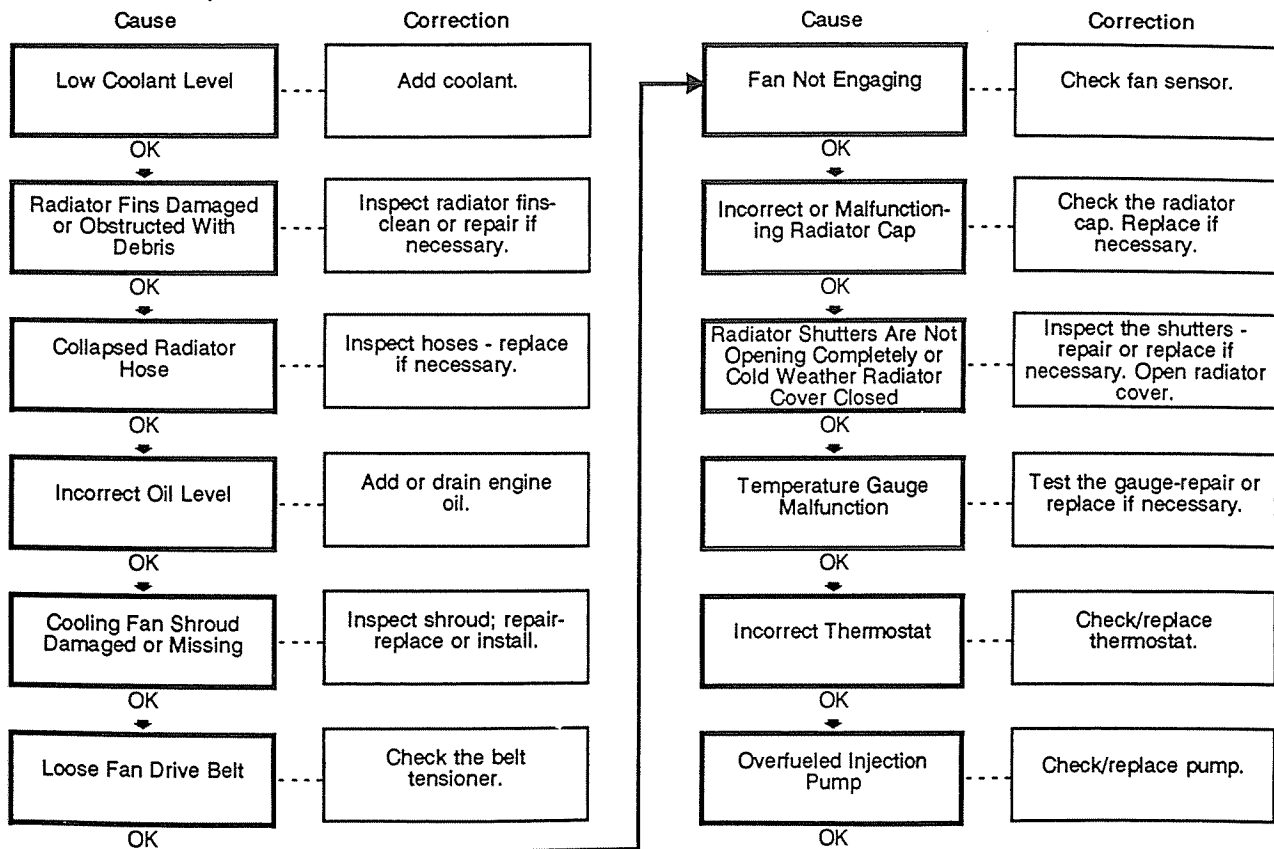

Coolant Temperature Above Normal (Continued)

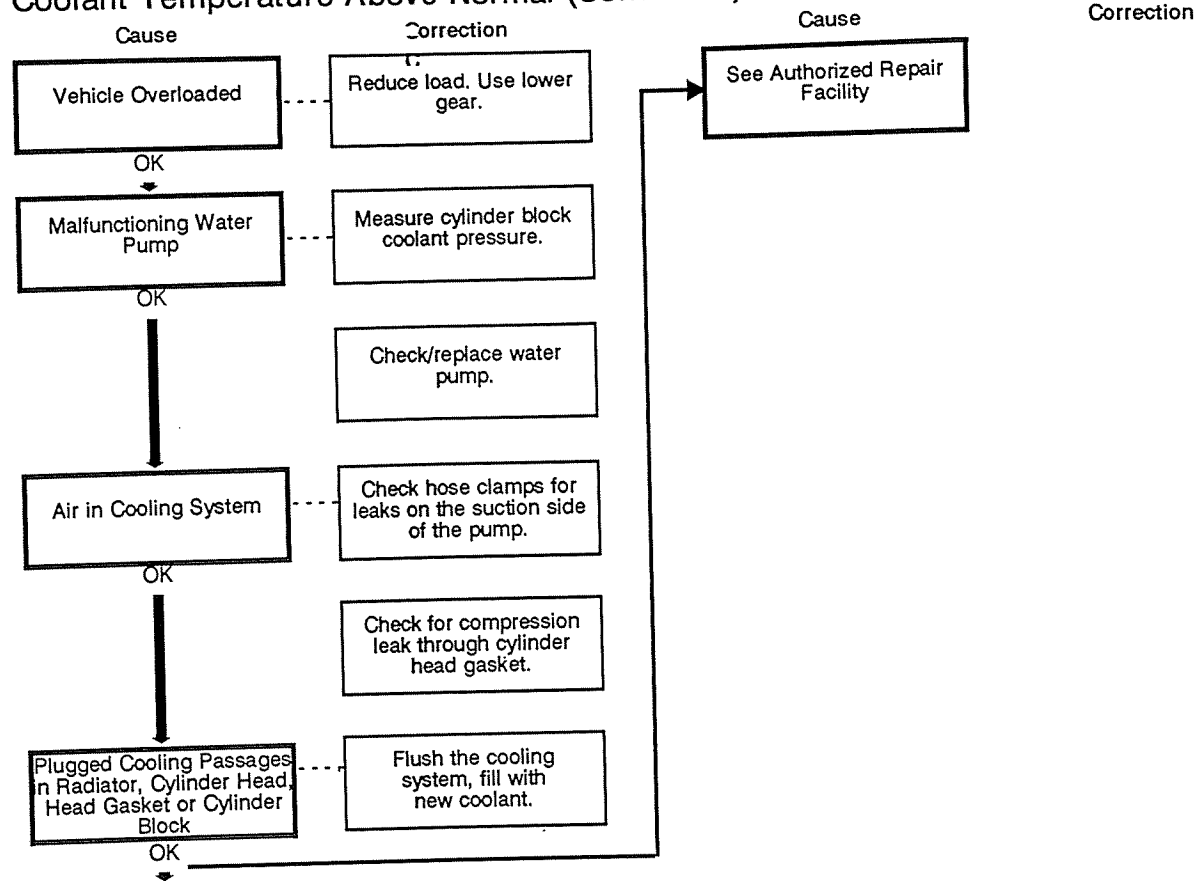

Coolant Loss

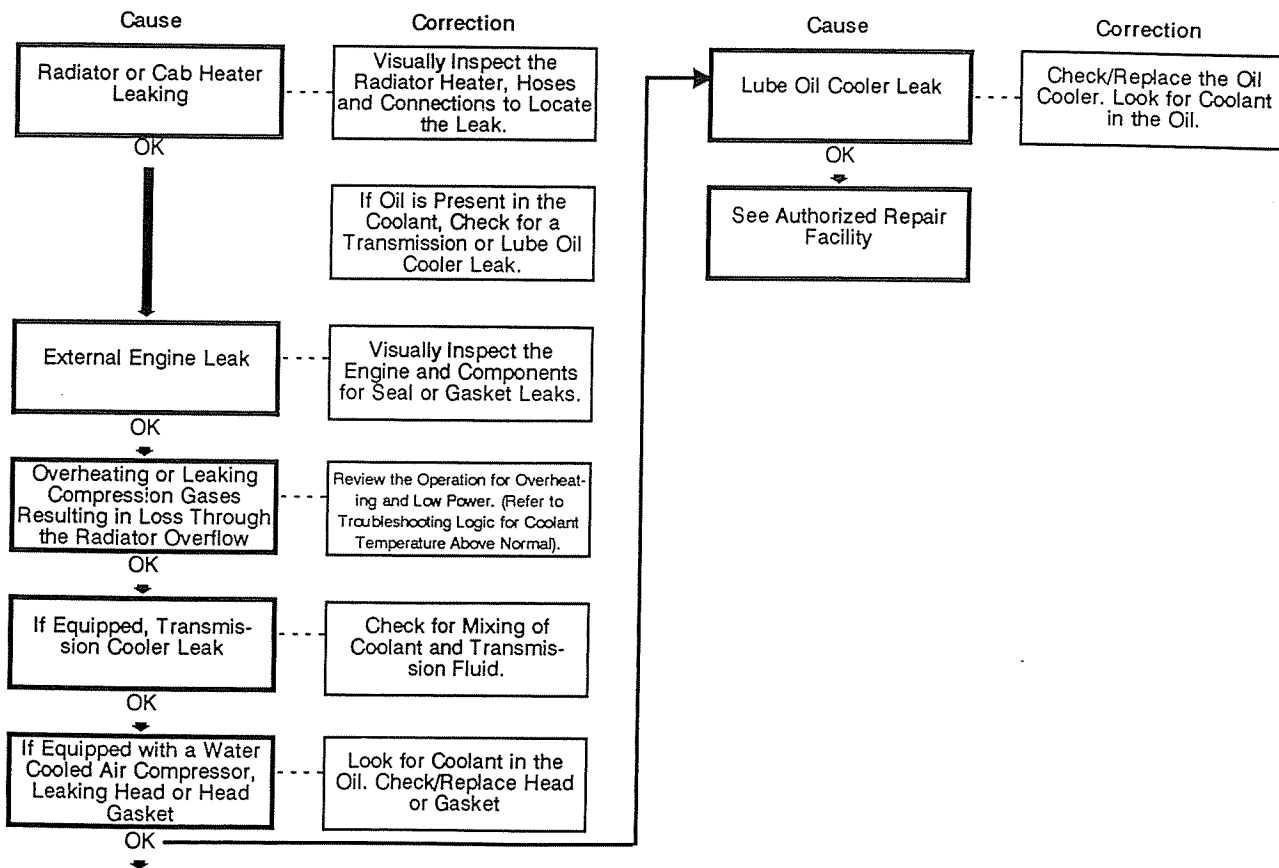

Coolant Temperature Below Normal

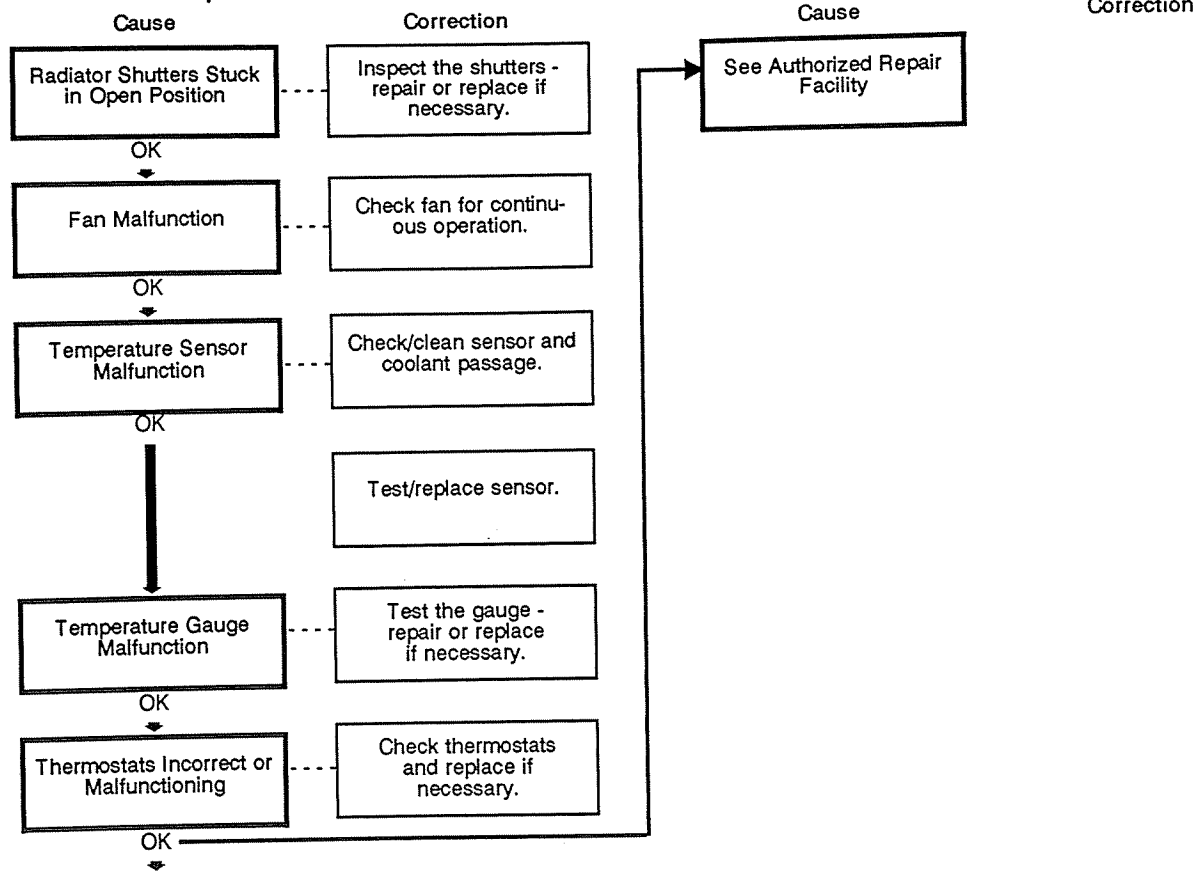

Contaminated Coolant

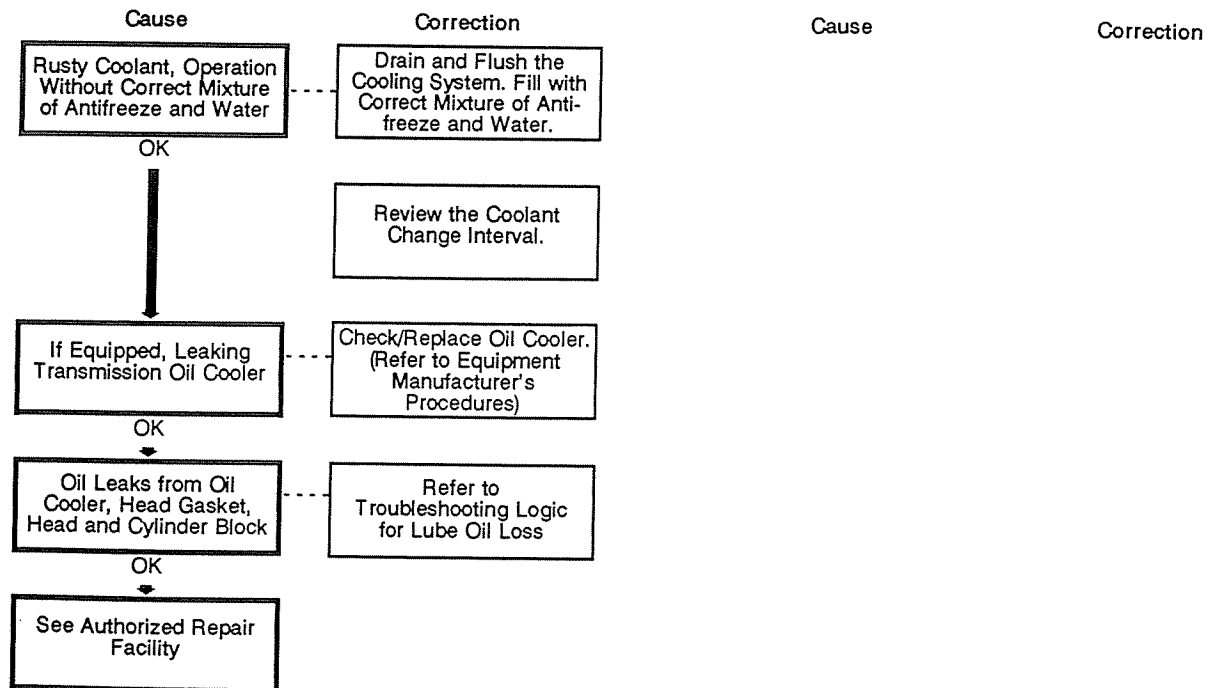

Exhaust Smoke Excessive Under Load

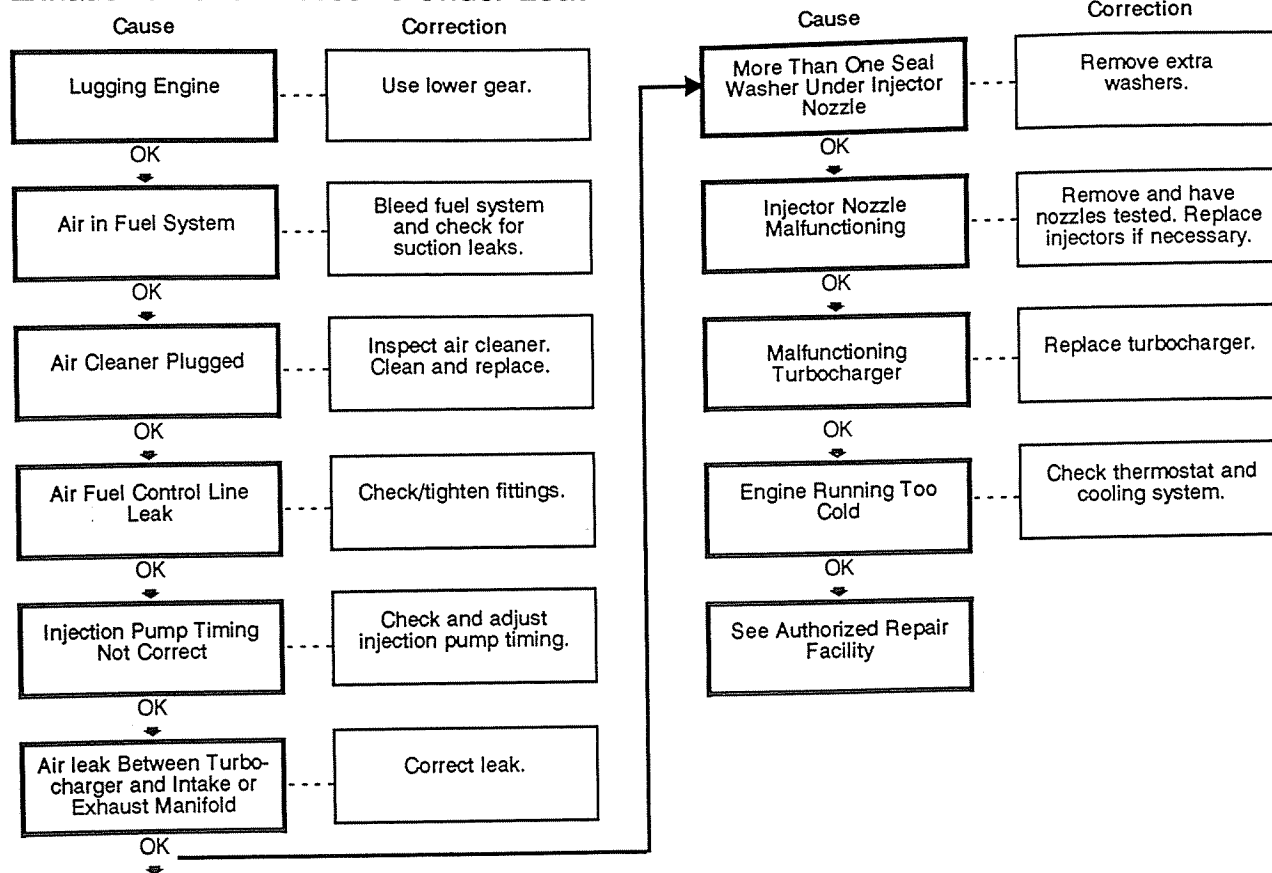

Engine Will Not Reach Rated Speed When Loaded

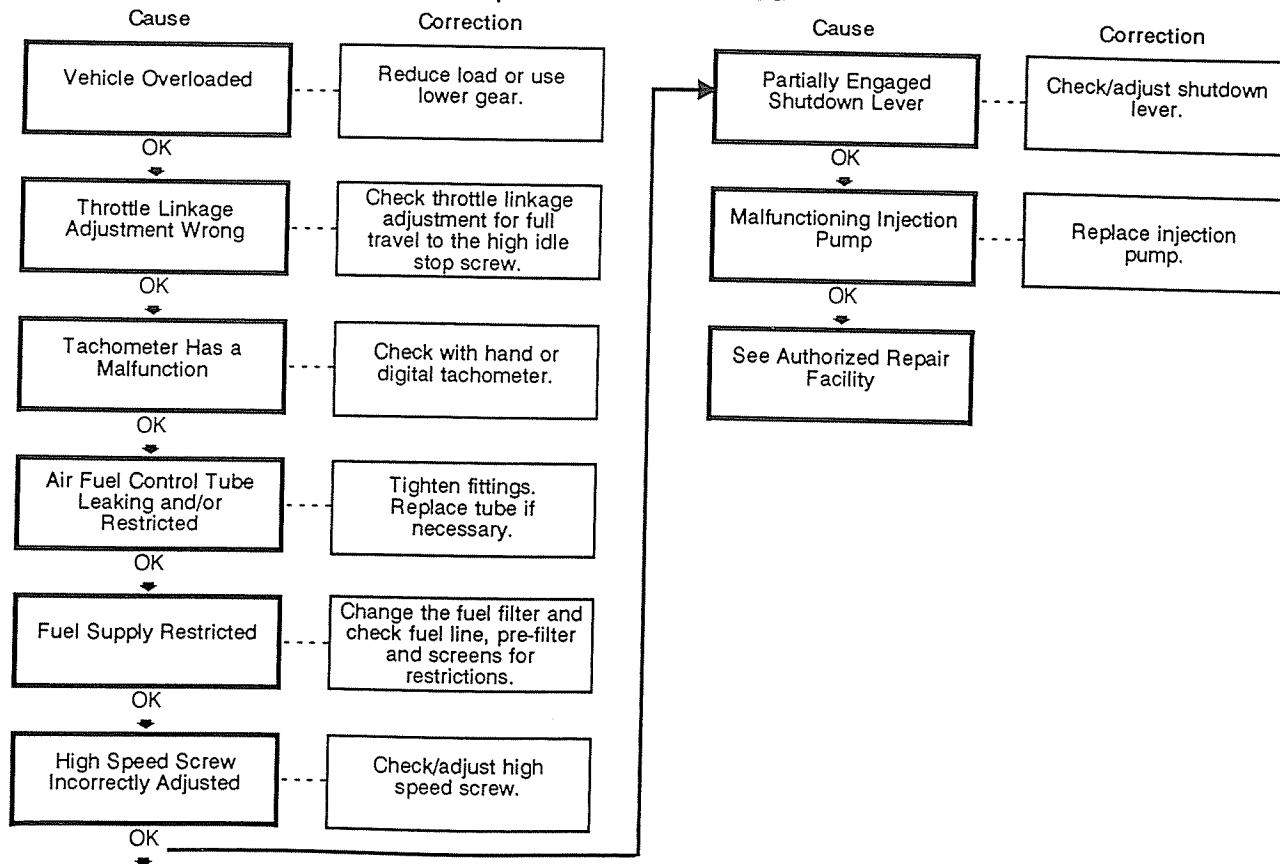

Low Power

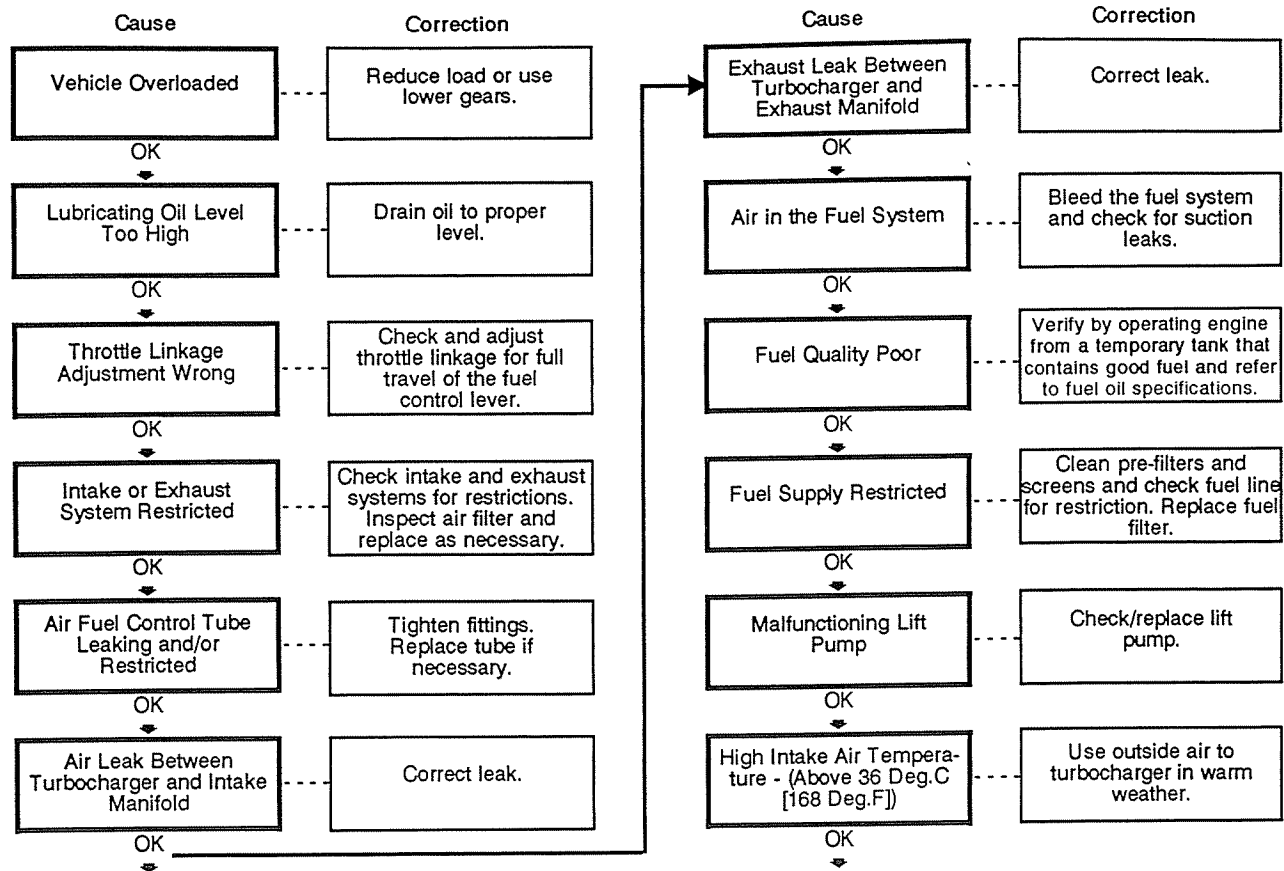

Troubleshooting
C Series

Low Power (Continued)

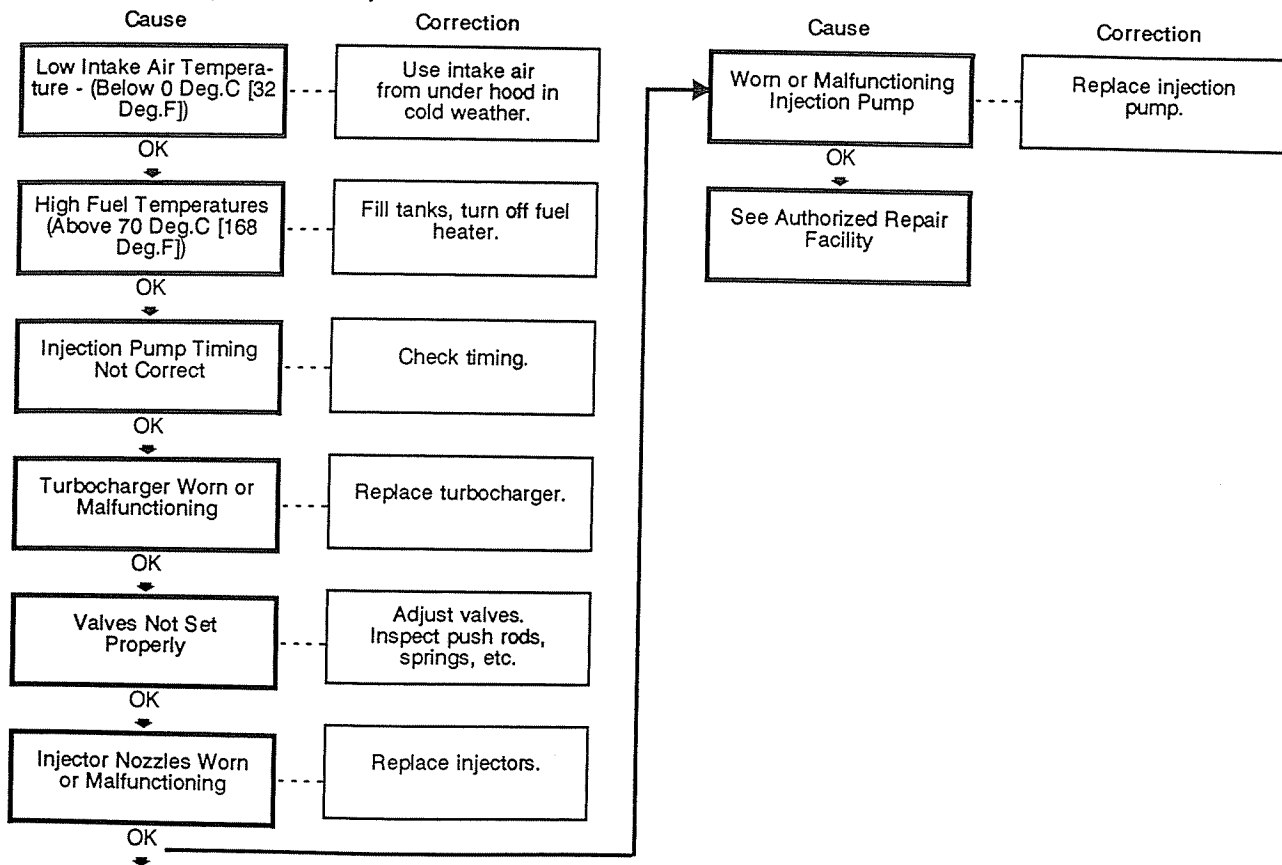

Engine Misfiring

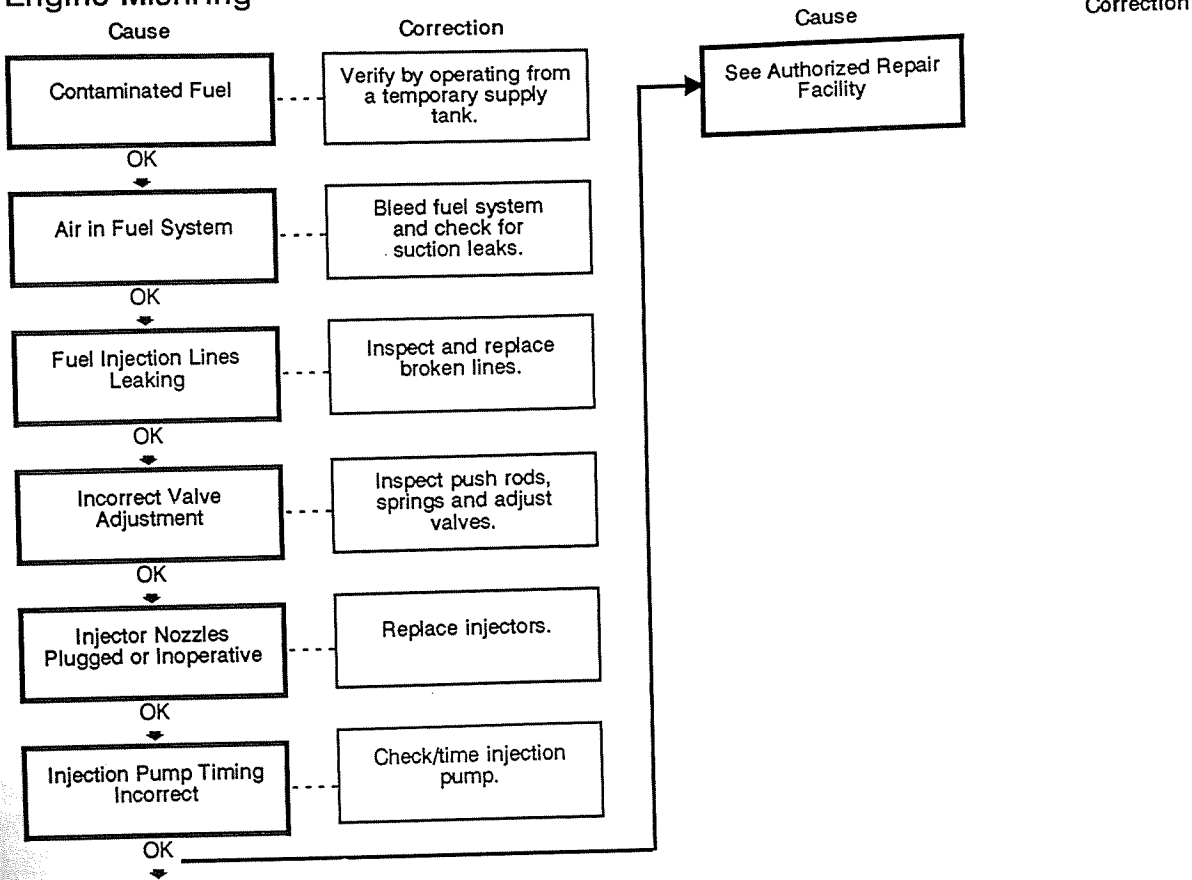

Troubleshooting C Series

Fuel Knock

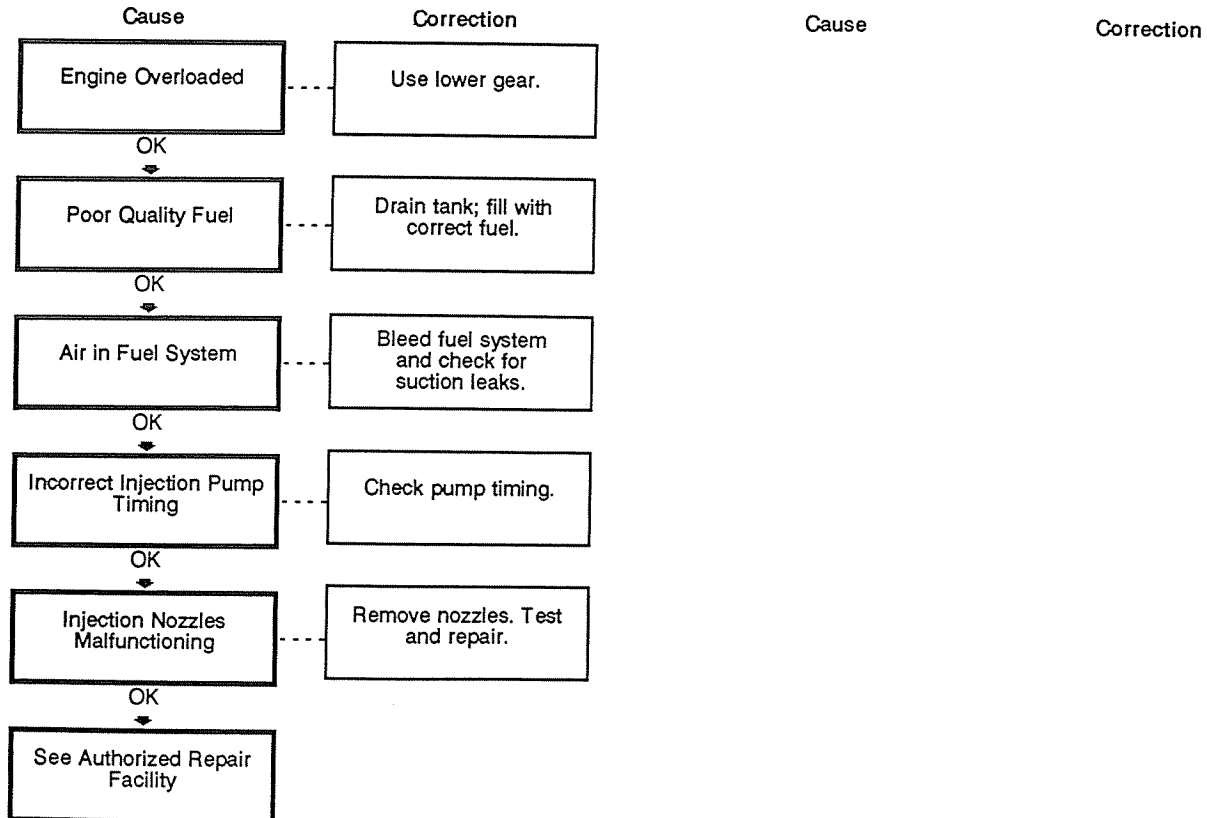

Excessive Fuel Consumption

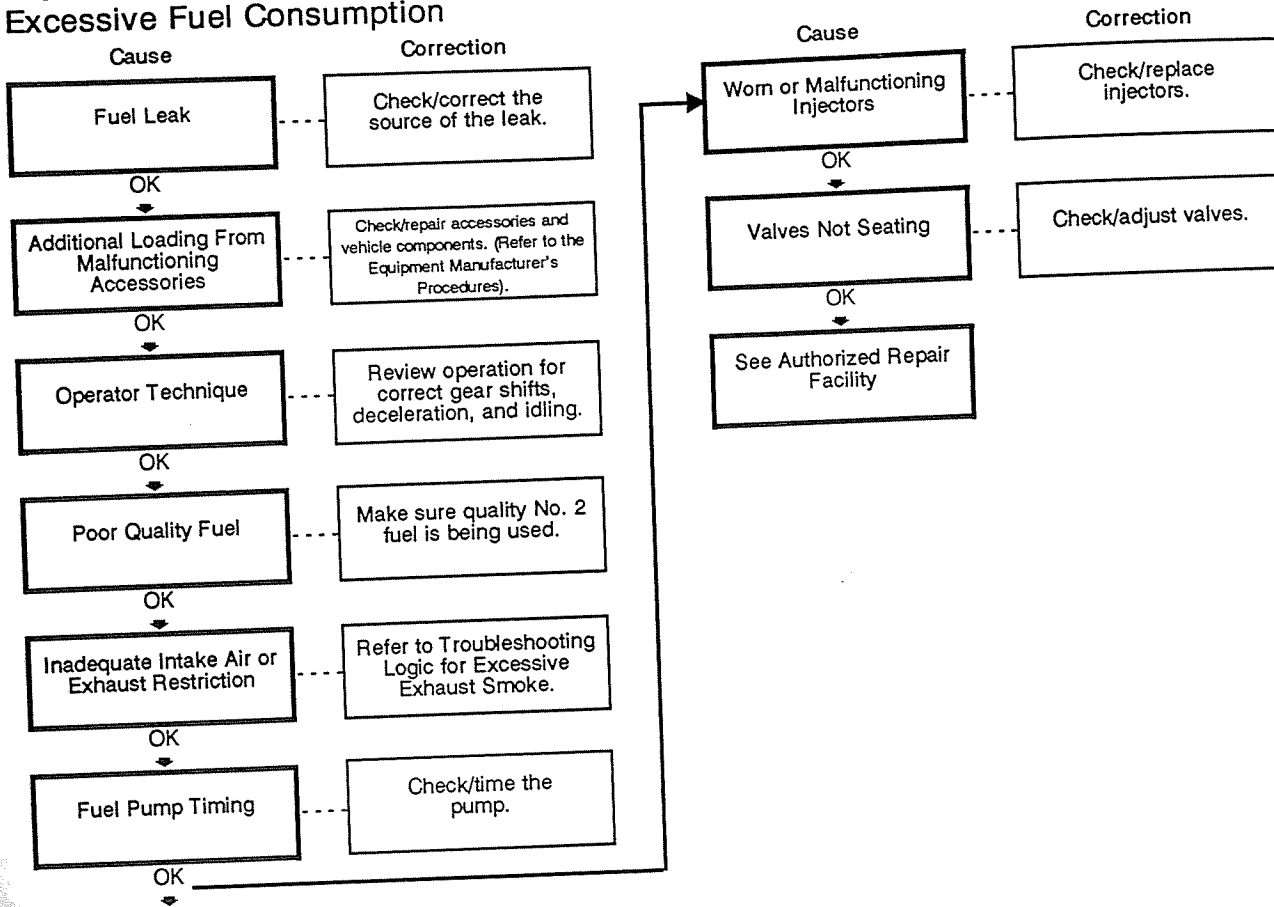

Excessive Vibration

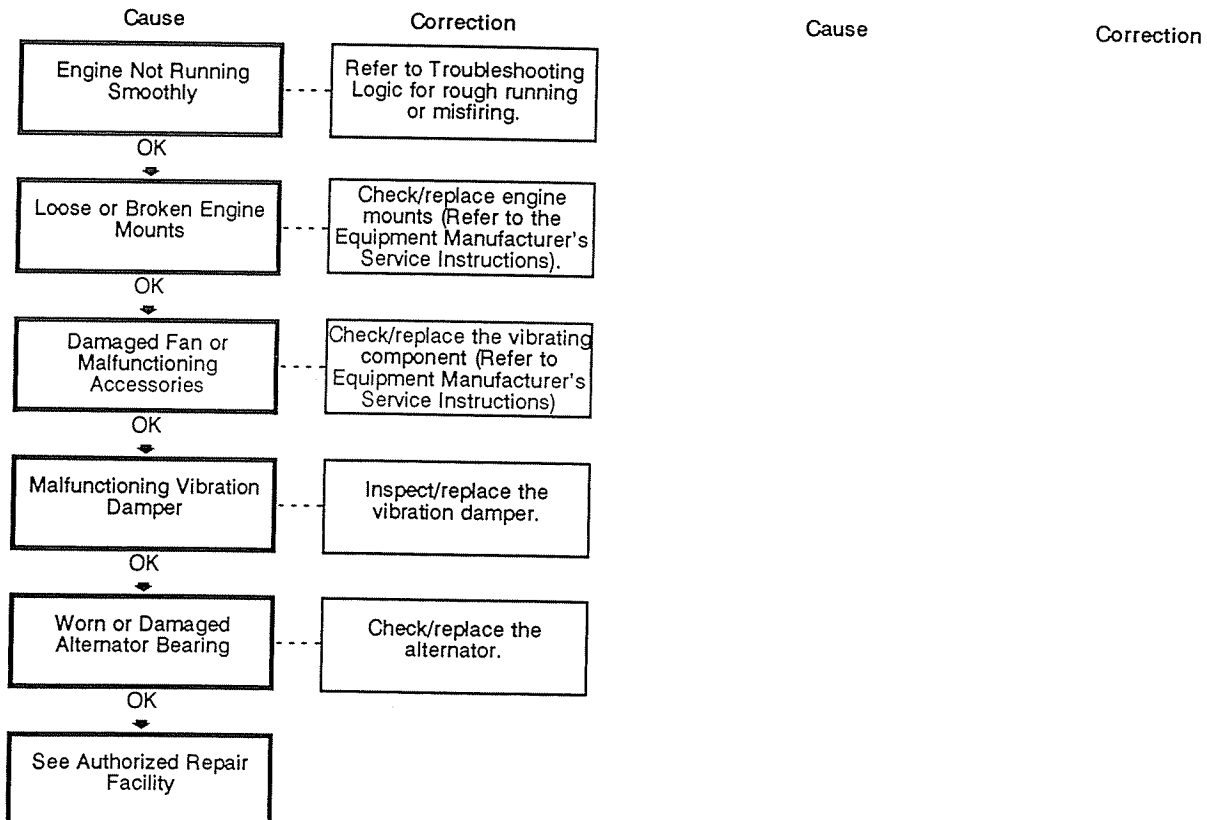

Excessive Engine Noises

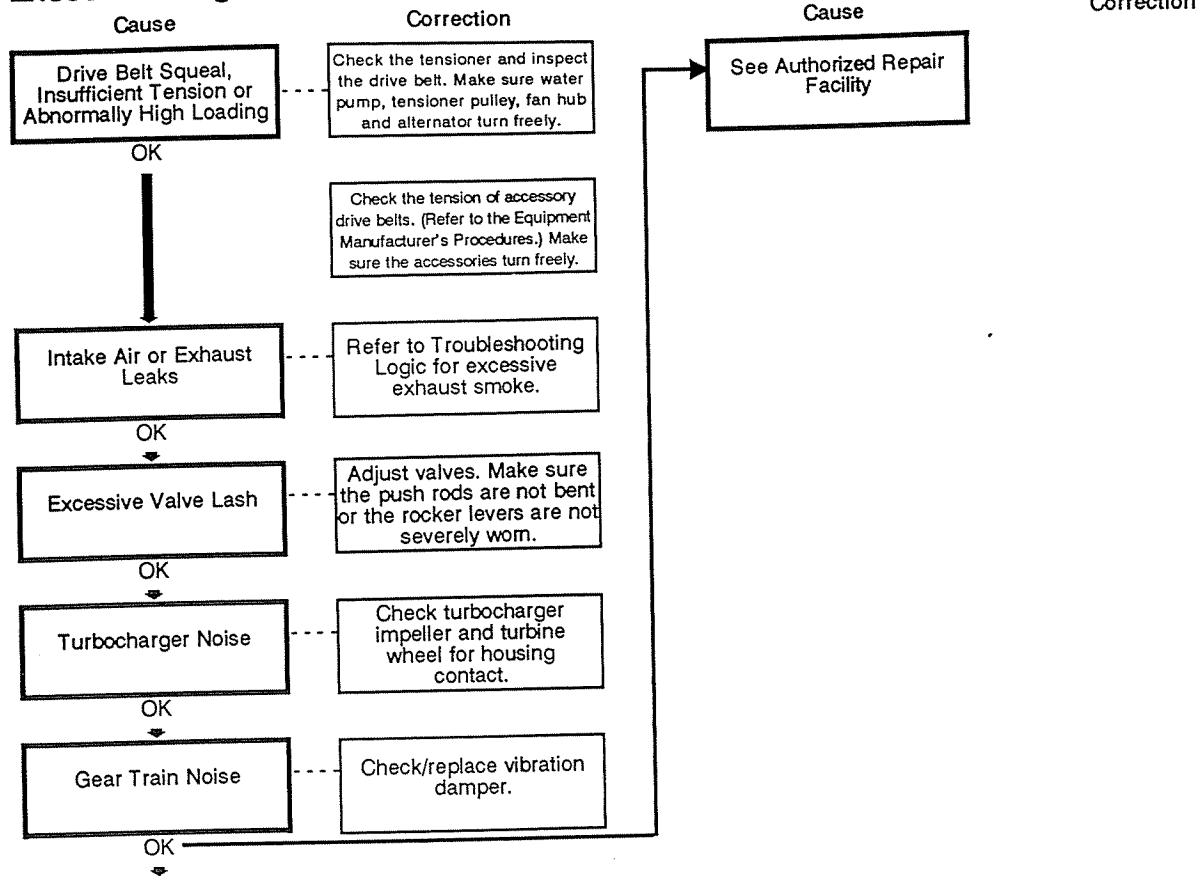

Alternator Not Charging or Insufficient Charging

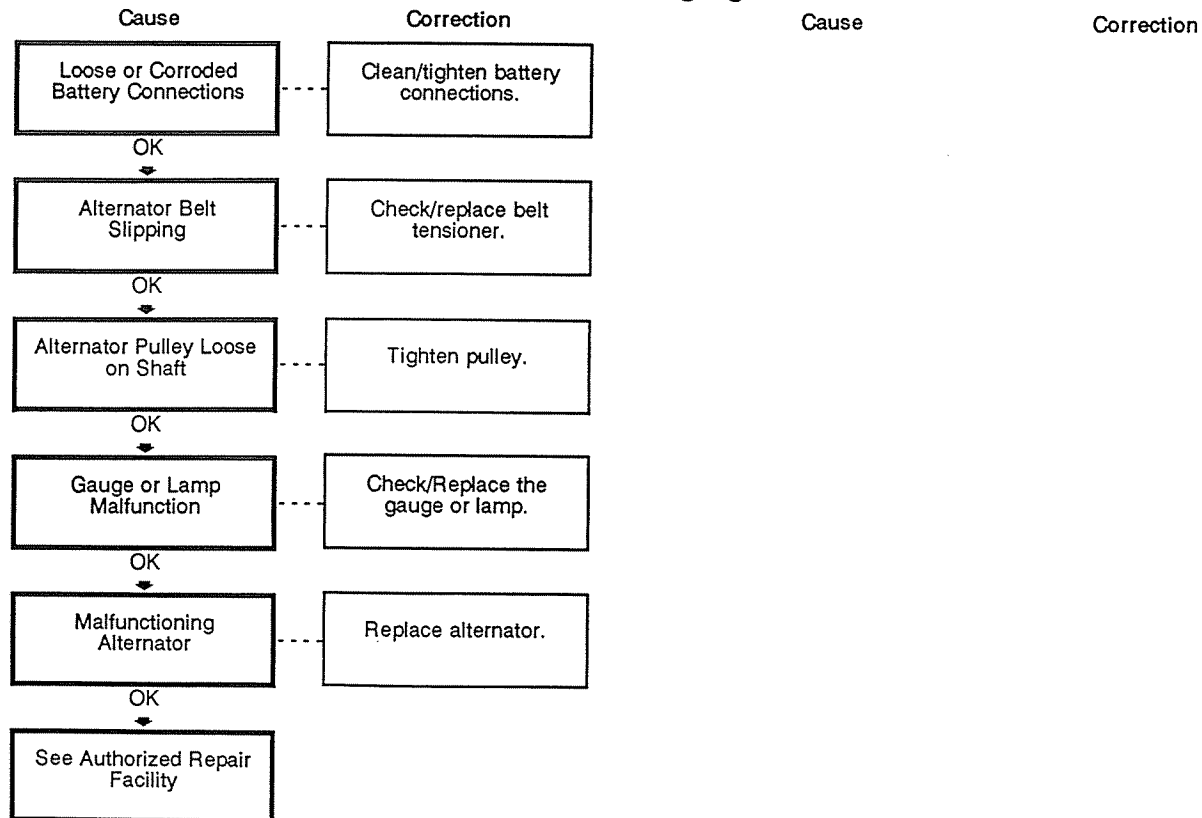

Section 4 - Adjustment, Replacement and Repair

Table of Contents

Subject	Page
Procedures.....	4-2
Repair Tools Required.....	4-3
Cooling System Repair Summary.....	4-4
Cooling System Repair.....	4-5
Fuel System Repair Summary.....	4-20
Fuel System Repair.....	4-21
Air System Repair Summary.....	4-48
Air System Repair.....	4-49
Lubricating System Repair Summary.....	4-74
Lubricating System Repair.....	4-75
Crankshaft Seal Repair Summary.....	4-86
Crankshaft Seal Repair.....	4-87
Electrical System Repair.....	4-98

Procedures
Page 4-2

Adjustment, Replacement and Repair
C Series

Procedures

The various repair procedures in this section have been organized by engine system. The summary statement of the steps and the tools needed for the replacement of a component, provided at the beginning of each group, will allow you to quickly assess the size of the task.

Follow the appropriate, illustrated steps to complete the repairs.

Symbols



Prior Information



Caution/Important



Inspect



Measure



Torque



Warning



Remove/Disassemble



Install/Assemble



Lubricate



Clean

Repair Tools Required

Sockets	Wrenches	Other
10mm		
12mm	8mm	Allen Wrench (8mm)
13mm	10mm	Breaker Bar (1/2 in. Sq. Drive)
15mm	13mm	Flat Screwdriver
17mm	15mm	Ratchet (3/8 in. Sq. Drive)
18mm	17mm (open end)	Ratchet (1/2 in. Sq. Drive)
19mm	19mm	Filter Wrenches (75-80mm, 90-95mm, and 118-131mm)
22mm	22mm	Drill Motor (1/4 inch)
27mm	24mm	Drill Bit (3mm)
		Slide Hammer
		Flat Chisel
		T-Bar Puller (75mm)
		Sheet Metal Screw (#10)
		Torque Wrench
		Pliers

Cooling System Repair Summary Page 4-4

Cooling System Repair Summary

Component To Be Replaced	Tools	Preparatory Steps
Drive Belt	Breaker Bar (1/2 inch square drive)	Remove Drive Belt
Belt Tensioner	Ratchet (1/2 inch drive) 15mm Socket and Torque Wrench	Remove Drive Belt and Fan Pulley
Fan Hub	10mm Socket/Wrench	Drain Coolant and Remove Drive Belt
Water Pump	10mm Socket/Wrench	Drain Coolant, Remove Drive Belt, Loosen Alternator Link, Remove Alter- nator Mounting Capscrew, Remove
Thermostat	10mm, 18mm and 19mm Socket/Wrench	Thermostat Housing

Cooling System Repair

Drive Belt - Replacement

1/2 Inch Square Drive

Lift the tensioner arm and pulley to remove and install the belt.

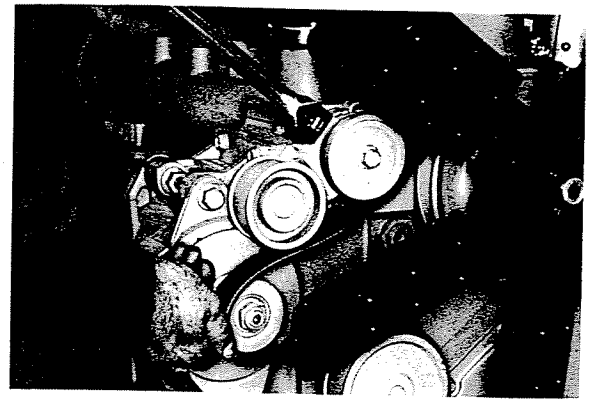

Belt Tensioner - Replacement

Preparatory Step:

- Remove the drive belt.

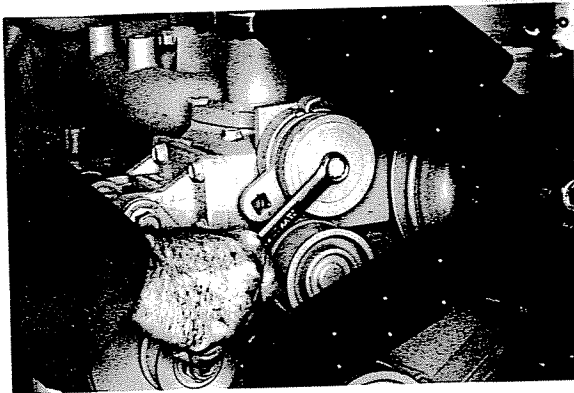

15 mm

Remove the belt tensioner from the bracket.

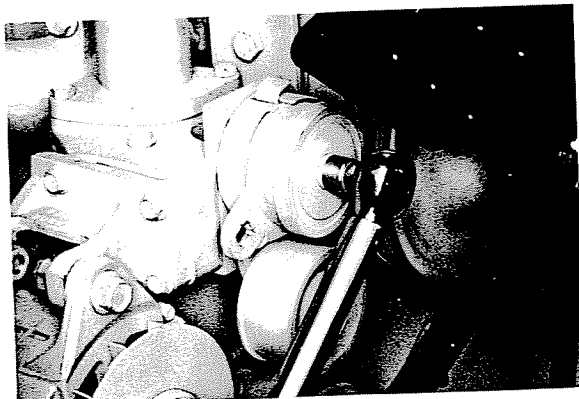

15 mm

Install the belt tensioner.

Torque Value: 43 N•m [32 ft-lbs].

Fan Pulley - Replacement

Preparatory Steps:

- Remove the drive belt.

Note: Loosen the capscrews before removing the belt and torque the capscrews after the belt is installed.



10 mm

Remove the four capscrews, fan and spacer. Replace the fan pulley.

Torque Value: 24 N•m [18 ft-lbs]

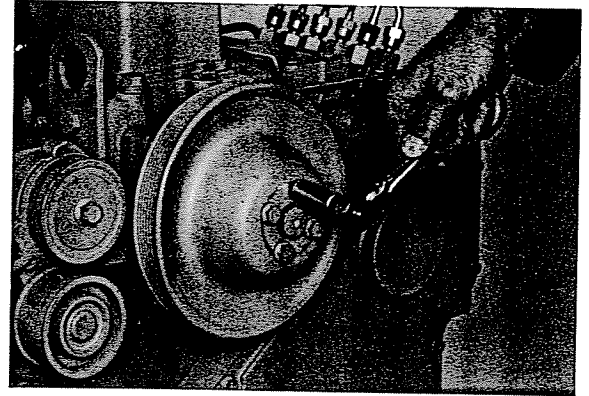

Water Pump - Replacement

Preparatory Steps:

- Drain the coolant.
- Remove the drive belt.

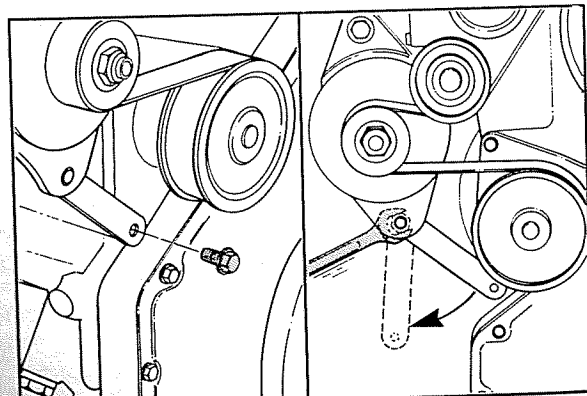

10 mm, 19 mm

Remove the alternator link.

10 mm

Remove the water pump.

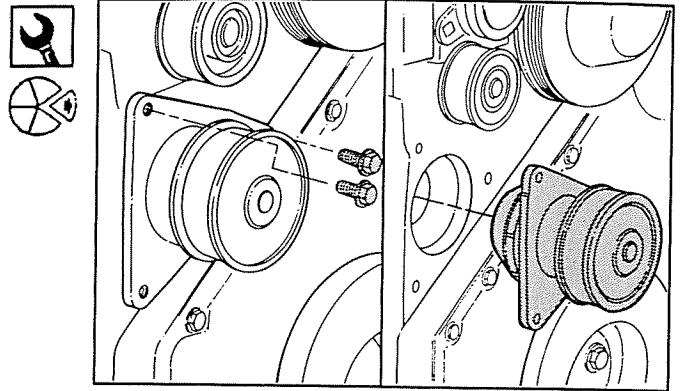

Clean the sealing surface on the cylinder block.

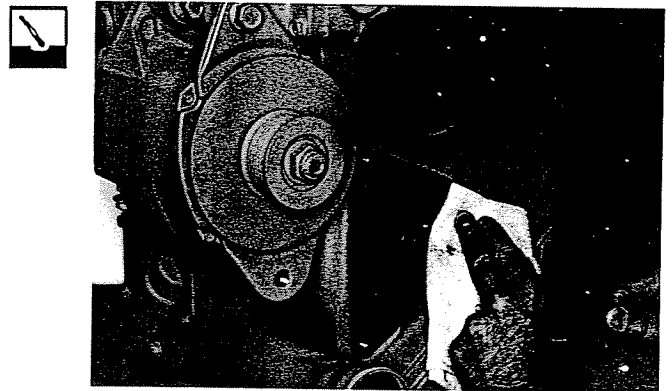

Install a new o-ring into the groove in the water pump.

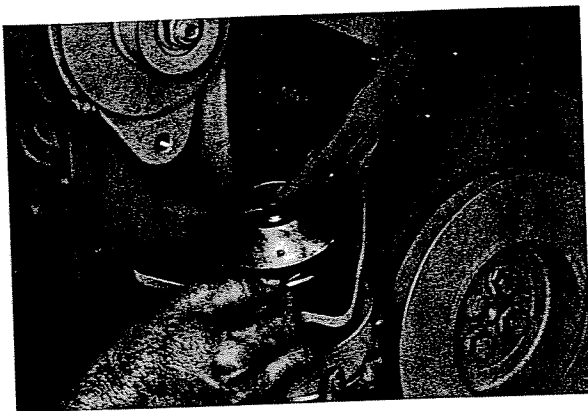

10 mm, 19 mm

Install the water pump and alternator link.



Torque Value:
(Water Pump) 24 N•m [18 ft-lbs]
(Alternator Link) 43 N•m [32 ft-lbs]

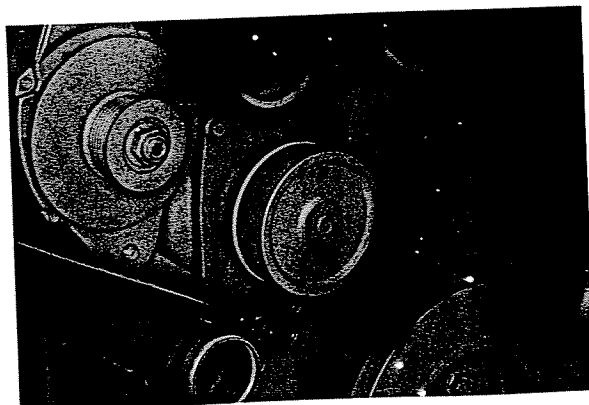

Lift the tensioner arm and pulley to install the drive belt.

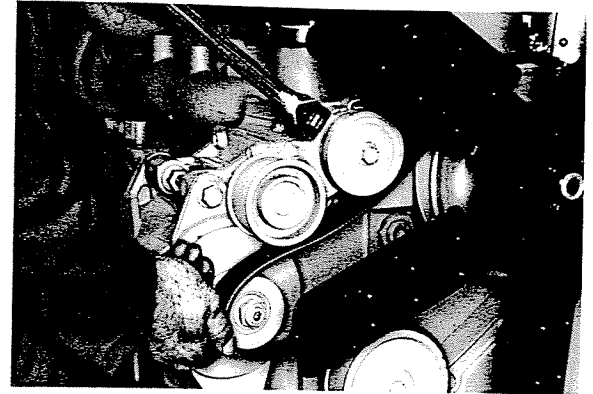

During filling, air must be vented from the engine coolant passages. Open the engine vent petcock. Also, be sure to open the petcock on the aftercooler for aftercooled engines.



The venting will permit a fill rate of 38 litres/minute [10 U.S. gallons/minute].

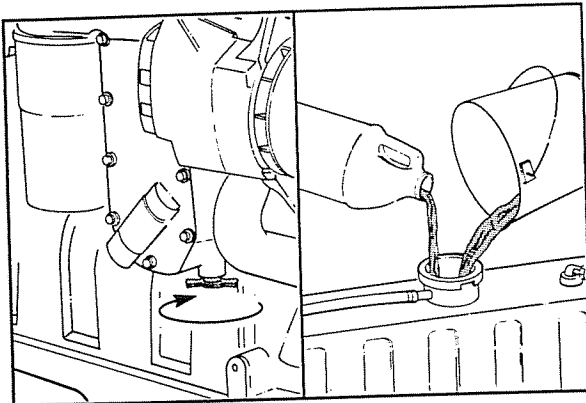
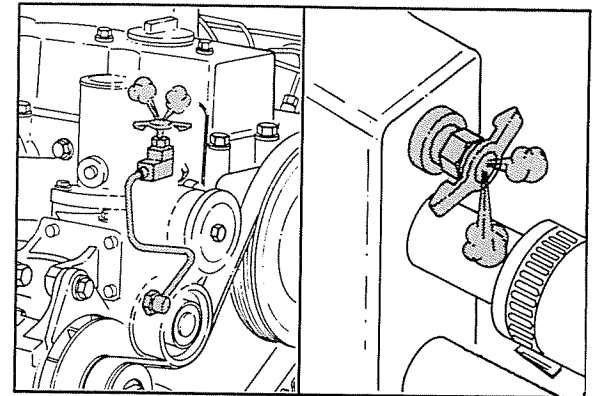

Close the drain valves. Fill the cooling system with a mixture of 50% water and 50% ethylene-glycol type antifreeze. Refer to Section 5 for the correct amount of DCA4 corrosion inhibitor.

Coolant Capacity (Engine Only)		Litre [U.S. Quarts]
6C8.3	6CT8.3	6CTA8.3
11.4 [12.0]	11.4 [12.0]	12.3 [13.0]

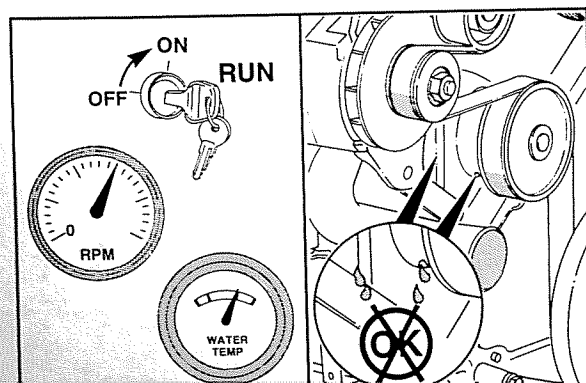

Install the pressure cap. Operate the engine until it reaches a temperature of 80° C [180° F], and check for coolant leaks.

Thermostat - Replacement

Preparatory Steps:

- Drain 2 litres (2.1 U.S. Quarts) of coolant.
- Remove the radiator hose from the outlet connection.
- Remove the drive belt.
- Disconnect the negative battery cable.

19 mm

Loosen the alternator link capscrew.

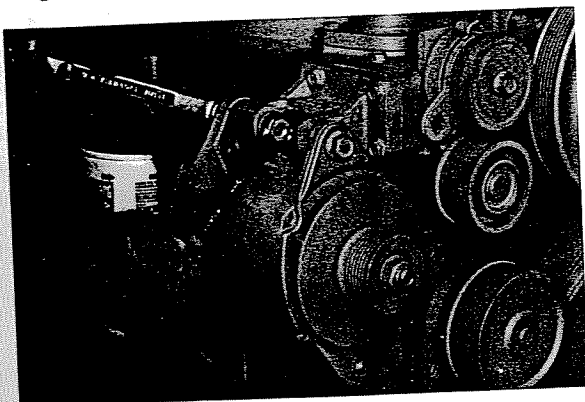
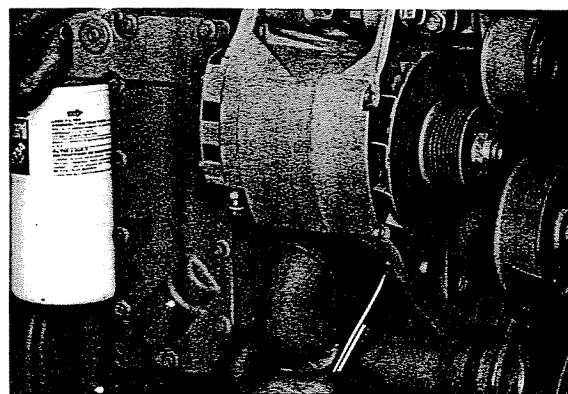

18 mm, 19 mm

Remove the alternator mounting bolts and nuts. Lower the alternator.

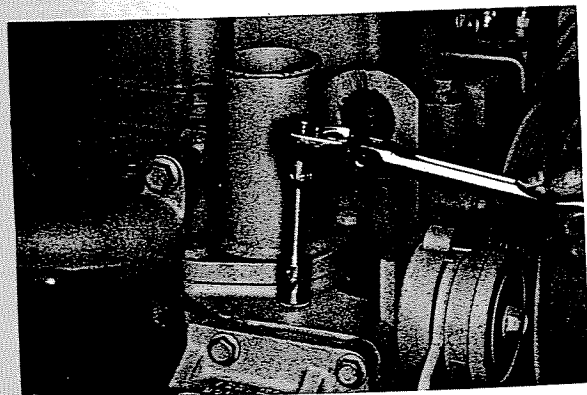

10 mm

Remove the capscrews from the thermostat housing and water outlet connection. Remove the water outlet connection.



Remove the thermostat housing and belt tensioner assembly.

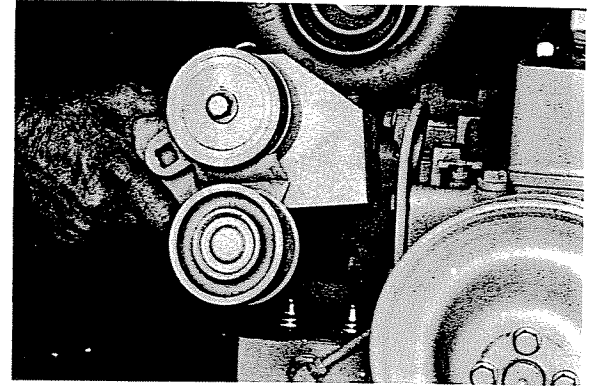

Remove the thermostats and clean the gasket surfaces.
Caution: Do not let any debris fall into the thermostat cavity when cleaning gasket surfaces.

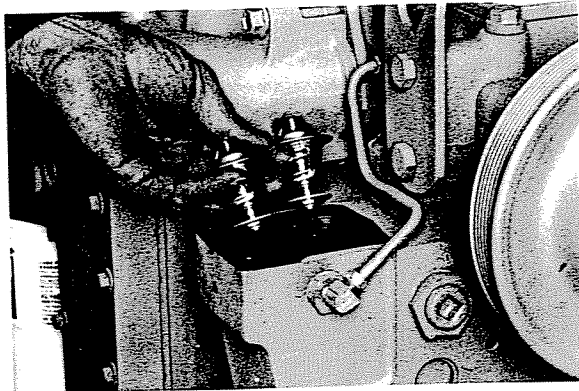
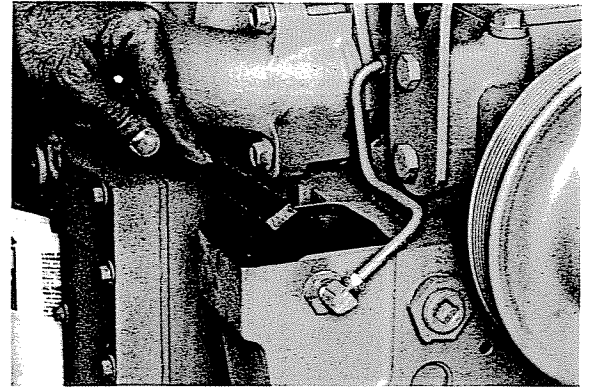

Install the new thermostats.

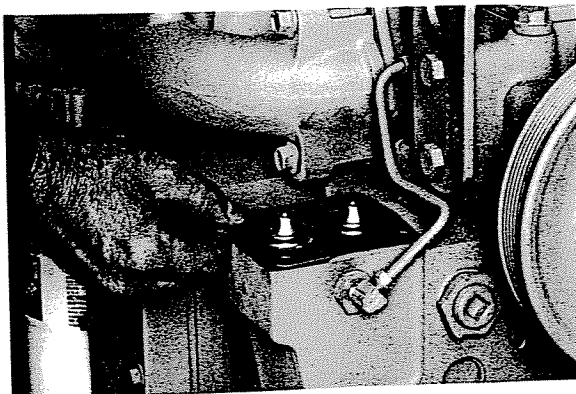

Position a new gasket over the thermostats.

Adjustment, Replacement and Repair
C Series

Position the thermostat housing and belt tensioner over the thermostats and gasket.

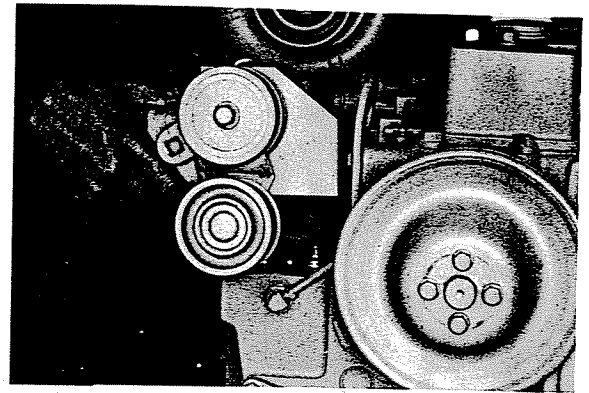

Make sure the gasket is aligned with the capscrew holes. Install the capscrews and use your fingers to tighten.

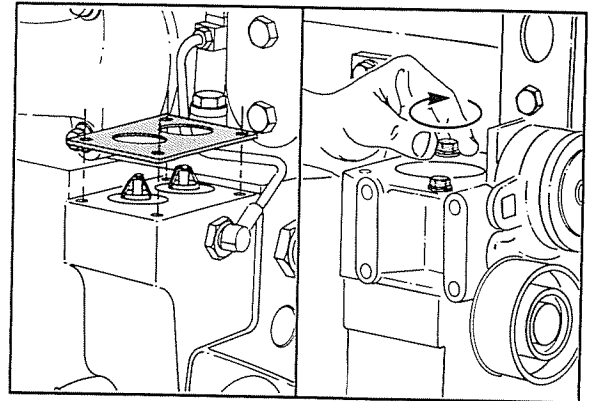

Cooling System Repair
Page 4-18

Adjustment, Replacement and Repair
C Series

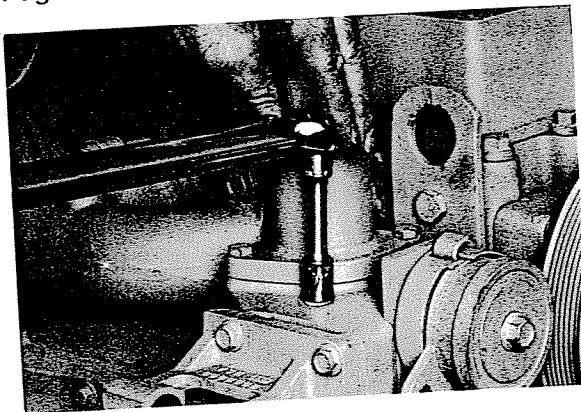

10 mm

Install the water outlet connection.



Tighten all capscrews.

Torque Value: 24 N•m [18 ft-lbs]

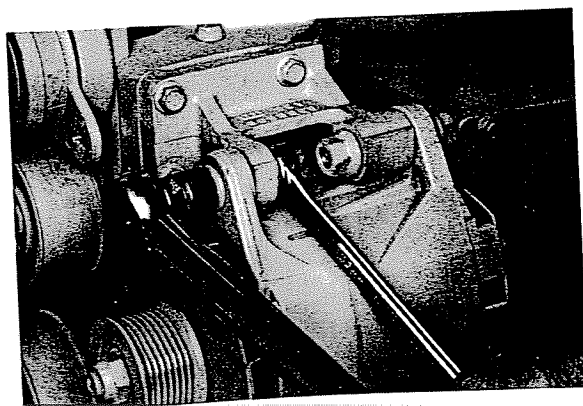

18 mm, 19 mm

Position the alternator and install the mounting bolts and nuts.



Torque Value:
(Alternator Mounting) 77 N•m [57 ft-lbs]
(Alternator Link) 43 N•m [32 ft-lbs]



Install the drive belt.

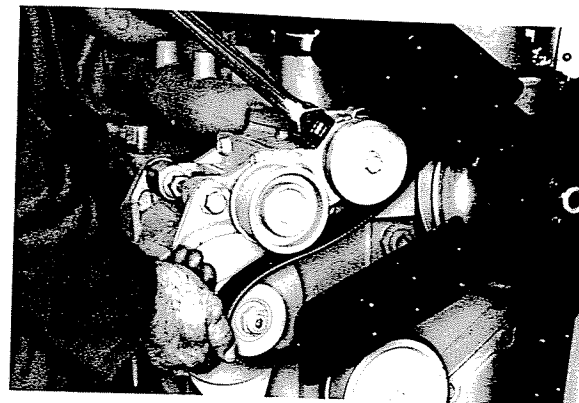

Fill the cooling system. Refer to page 4-10. Operate the engine and check for leaks.

Caution: Be sure to vent the engine and aftercooler during venting.

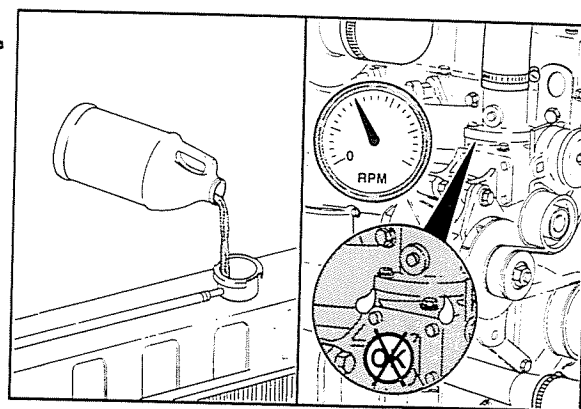

Fuel System Repair Summary
Page 4-20

Fuel System Repair Summary

Component To Be Replaced	Tools
Lift Pump	10, 14 and 20mm Wrenches
High Pressure Lines	17mm Open End Wrench and a Torque Wrench
Injector Fuel Drain Manifold	10mm and 19mm Wrenches, 10mm and 19mm Sockets, and a Torque Wrench
Injectors	10mm and a Torque Wrench Injector Bore Cleaning Brush
Injection Pump	Ratchet, 22mm Socket, 75mm T-Bar Puller (w/2 8mm capscrews) 1/2 in. open end Wrench 13mm Socket, 13mm Wrench and a Torque Wrench
Fuel Solenoid	10mm Wrench
Fuel Filter Head	24mm, 75-80mm and 90-95mm Filter Wrench

Adjustment, Replacement and Repair
C Series

Preparatory Steps

Clean debris.

Clean debris.

Clean debris.

Disconnect the high pressure lines and fuel drain manifold.

Remove high pressure lines, supply line and disconnect fuel drain manifold.

Label and disconnect wiring.

Clean debris.

Fuel System Repair

Fuel System Components - Cleaning

Thoroughly clean all fittings and components before removal. Make sure that the debris, water, steam or cleaning solution does not reach the inside of the fuel system.

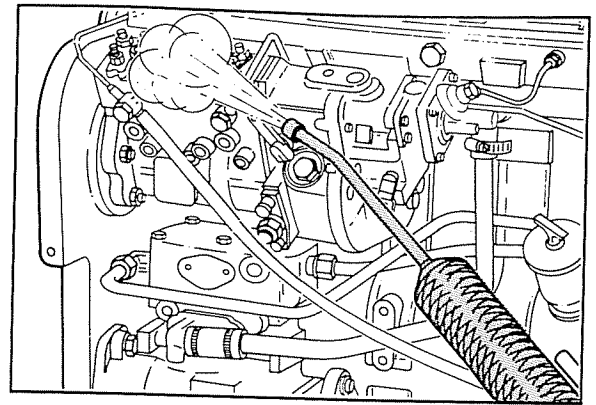

Low Pressure Fuel Line - Replacement

Preparatory Step:

- Clean debris from fittings.

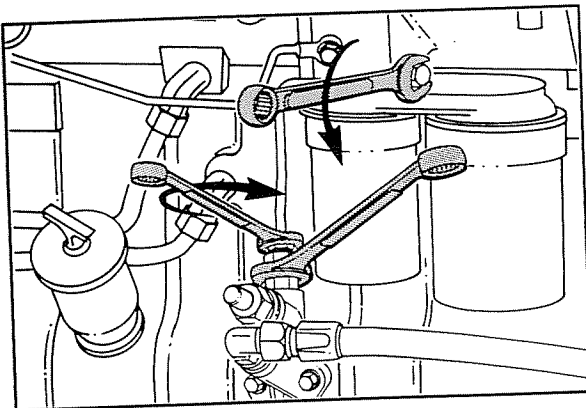

14 mm, 17 mm, 20 mm

Disconnect the fuel line from the lift pump and filter head. Use two wrenches to disconnect the line from the lift pump.

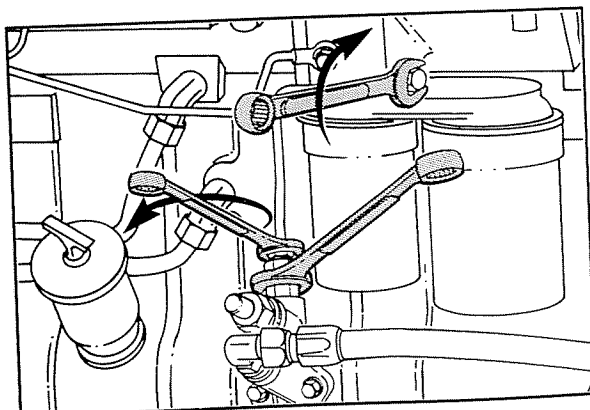

14, 17 mm, 20 mm

Install the fuel line to the lift pump and filter head. Use two wrenches to tighten the connection to the lift pump.

Torque Value: 24 Nm [18 ft-lbs]

Fuel Filter Head Adapter - Replacement

Preparatory Steps:

- Clean debris.
- Remove fuel filters.

24 mm

Remove the retaining nut, filter head adapter and sealing washers.

Install in the reverse order of removal.

Torque Value: 32 N•m [24 ft-lbs]

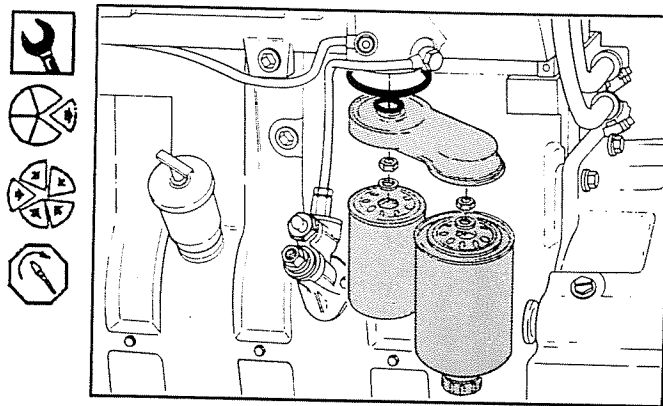

Lift Pump - Replacement

Preparatory Steps:

- Clean debris.
- Disconnect the fuel lines.

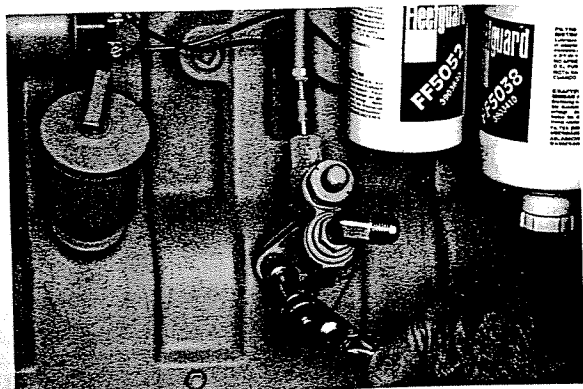

10 mm

Remove the lift pump.

Clean the mounting surface on the cylinder block.

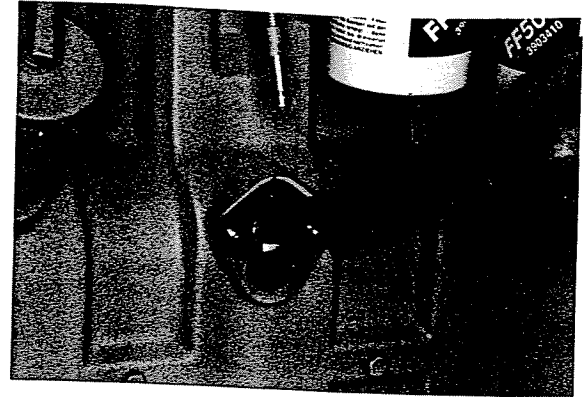

10 mm

Install the lift pump and a new gasket.

Connect the fuel lines.

Torque Value: 24 N•m [18 ft-lbs]

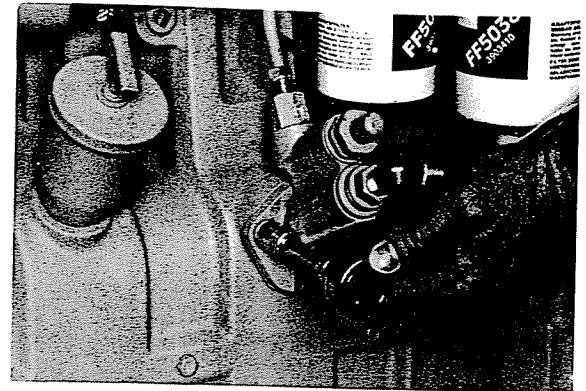

High Pressure Fuel Lines - Replacement

Preparatory Steps:

- Clean debris.

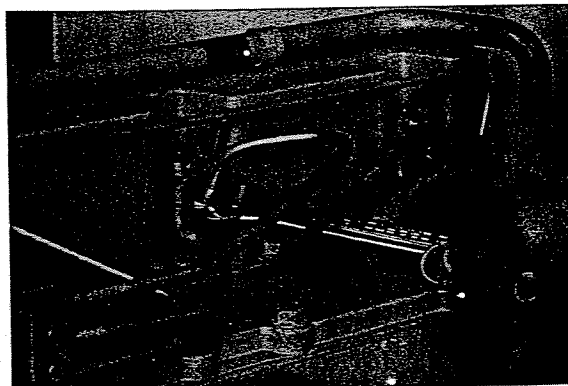

8 and 17 mm

Note: If individual lines are to be replaced, remove the support clamp from the set of lines containing the line to be replaced.

Disconnect the line(s) from the injectors.

17 mm

Disconnect the line(s) from the fuel pump.

Caution: If removed, reinstall the support clamp in the original position and make sure the lines do not contact each other or another component.

Install the lines in the reverse order of removal.

Torque Value:

(Line Fittings) 25 N•m [18 ft-lbs]

(Support Clamp) 6 N•m [4 ft-lbs]

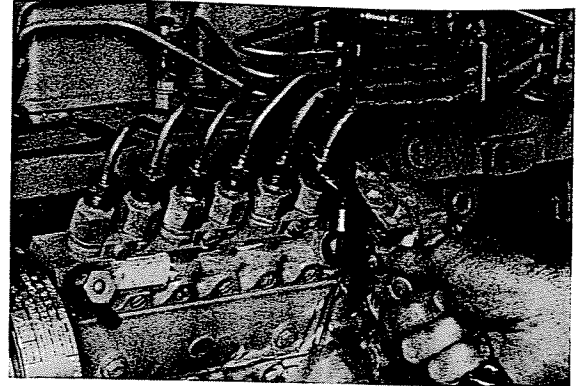

Fuel Drain Manifold - Replacement

Preparatory Steps:

- Clean debris.

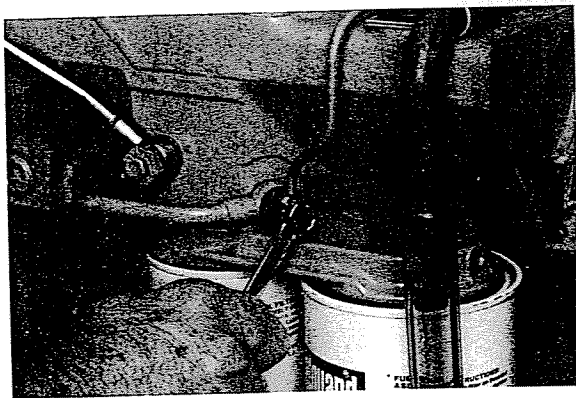

10 mm

Remove the drain line banjo cap screw from the fuel filter head.

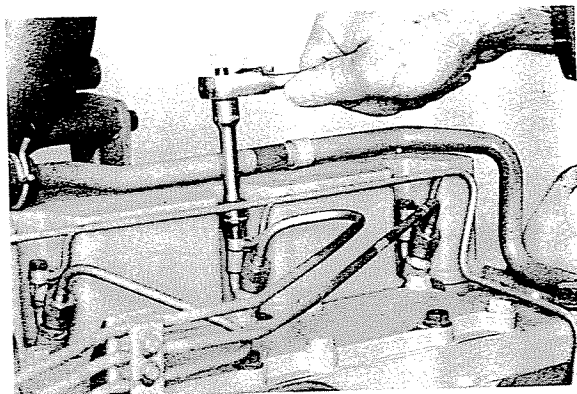

10 mm

Remove the banjo cap screws from the injectors.

Install the manifold in the reverse order of removal.

Torque Value: 8 N•m [6 ft-lbs]

Injectors - Replacement

Preparatory Steps:

- Thoroughly clean around the injectors.
- Disconnect the high pressure fuel lines.
- Disconnect the fuel drain manifold.

10mm

Remove the injectors.

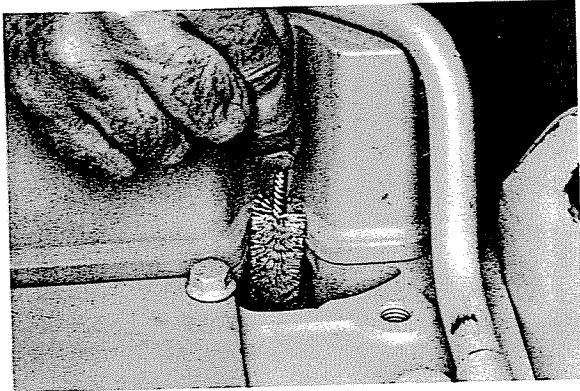
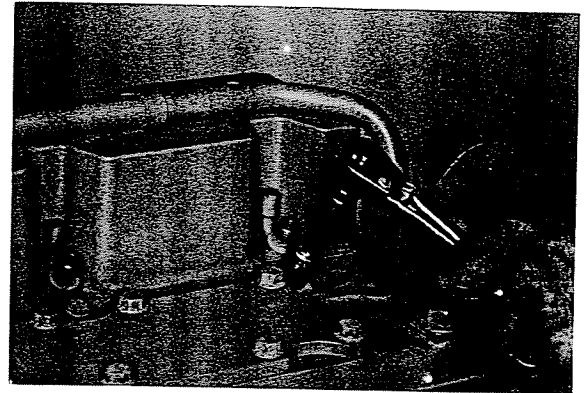

Injector Bore Brush

Clean the injector nozzle bore.



Lubricate the sealing lips of the sleeve with anti-seize compound. Package the injector, sealing sleeve, a new copper sealing washer and the holddown clamp.

Use only one washer.

Service Tip: A light coat of clean 15W40 engine oil between the washer and injector can help to keep the washer from falling during installation.

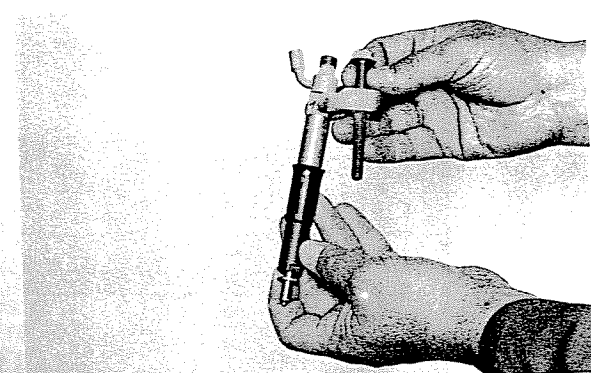

Install the injector package into the injector bore. The injector leak off connection must be toward the valve cover.

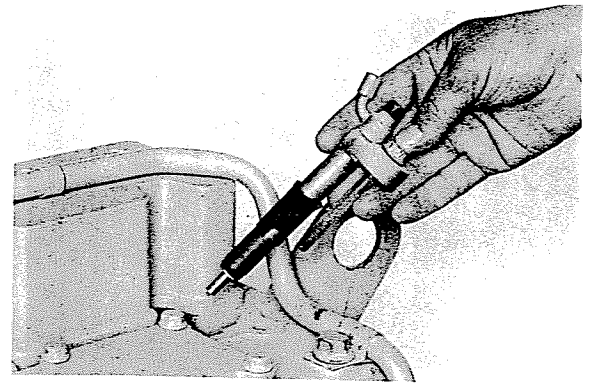

10 mm

Install the holddown capscrew.

Torque Value: 24 N•m [18 ft-lbs]

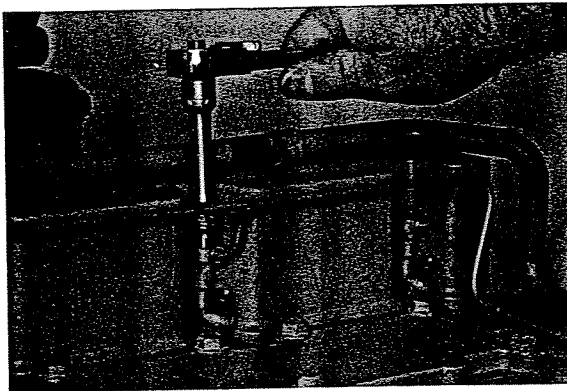
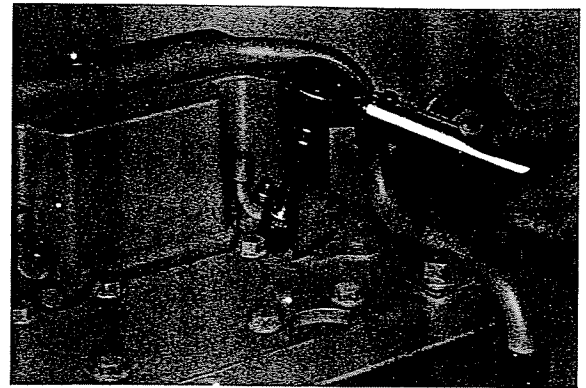

10 mm

Install the fuel drain manifold.

Torque Value: 8 N•m [6 ft-lbs]

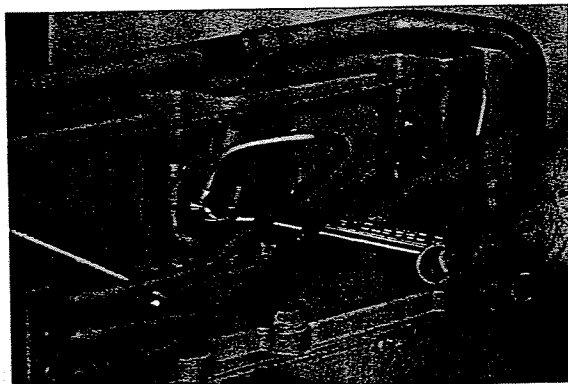

17 mm

Install the high pressure fuel lines.

Torque Value: 24 N•m [18 ft-lbs]

Fuel Shut Off Solenoid - Replacement

Preparatory Steps:

- Label and disconnect the wiring.

10 mm

Remove the mounting capscrews.

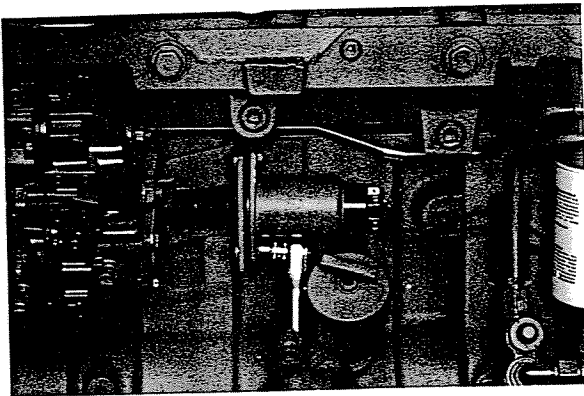
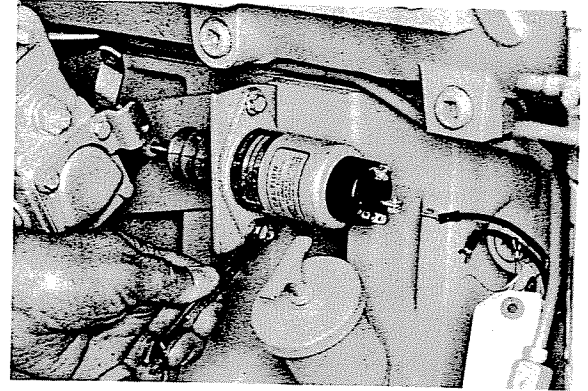

Caution: Be sure the acorn nut is tightened to be snug on the shaft.



Install the new solenoid and connect the wires.



Torque Value: 10 N•m [7 ft-lbs]

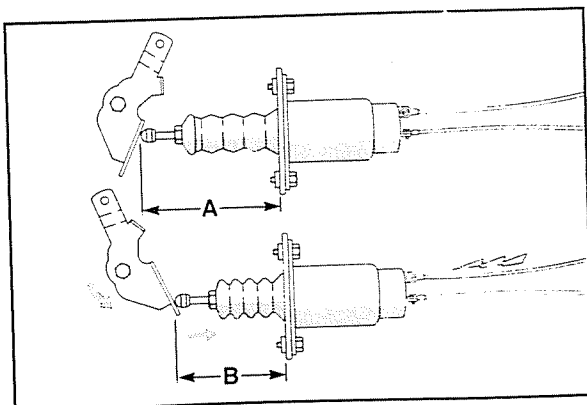

Activate the switch and check the plunger travel.

A = 86.6 mm [3.4 in.]
B = 60.2 mm [2.4 in.]



The plunger must be retracted when the solenoid is activated to the run position "B". The solenoid must operate without binding.

Fuel Pump - Replacement

Preparatory Steps:

- Clean debris.
- Remove all fuel lines.
- Remove control linkage.
- Remove fuel shut off solenoid.

Removing the Fuel Pump

Locate TDC for cylinder number 1. Push the TDC pin into the hole in the camshaft gear while slowly barring the engine.

Be sure to disengage the pin after locating TDC.

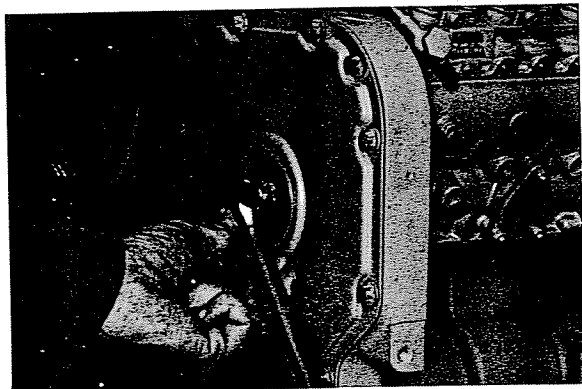
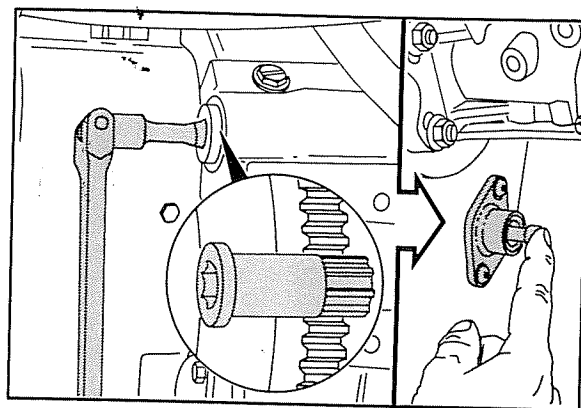

22 mm (PES6A Pump), 27 mm (PES6MW Pump)

Remove the gear cover access cap.



Remove the nut and washer from the fuel pump shaft.

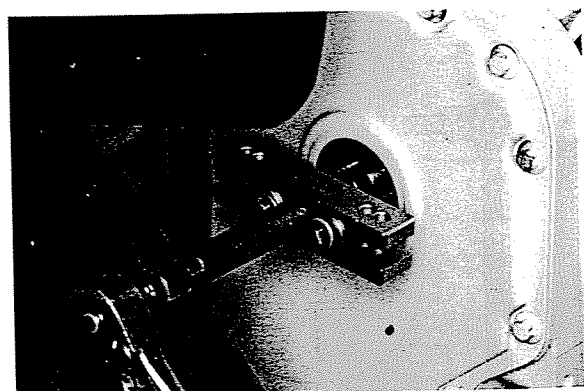

75 mm T-Bar Puller

Pull the fuel pump drive gear loose from the shaft.



15 mm

Remove the four mounting nuts.

Remove the fuel pump.

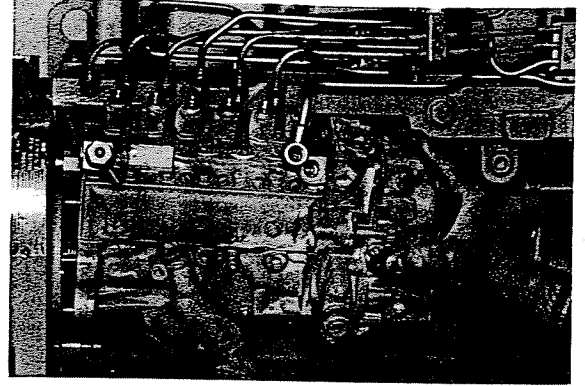

Installing the Fuel Pump

Make sure the engine has cylinder number 1 at TDC.

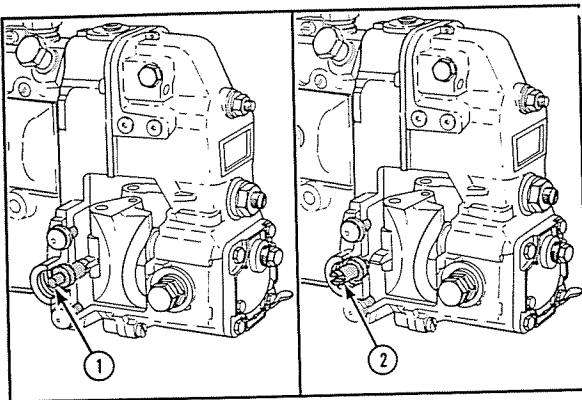
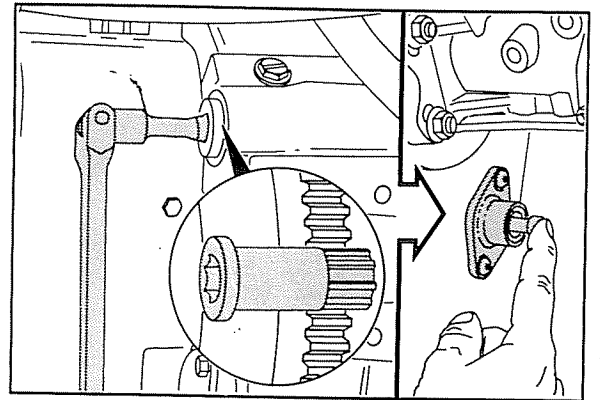

The injection pump also has a timing pin (1), located in the governor housing, to position the pump shaft to correspond with TDC for cylinder number 1. After the pump is installed the pin is to be reversed and stored in the housing (2).

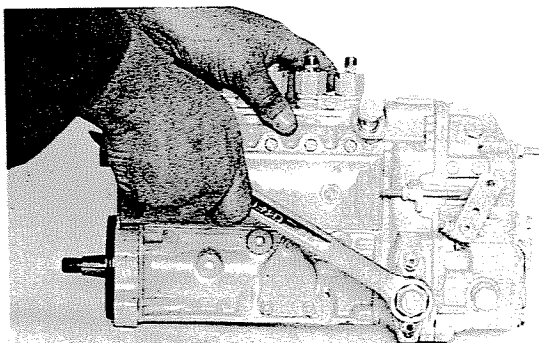

24 mm

Remove the access plug.

Remove the timing pin.

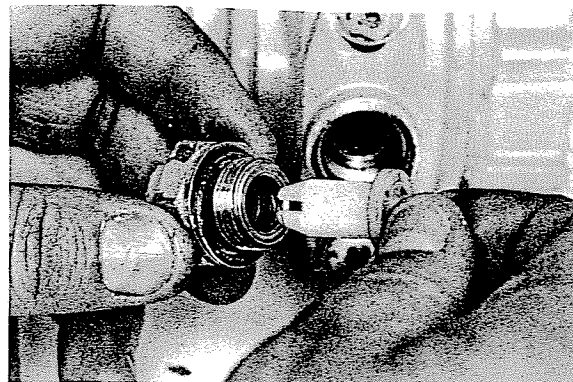

If the timing tooth is not aligned with the timing pin hole, rotate the pump shaft until the timing tooth aligns.

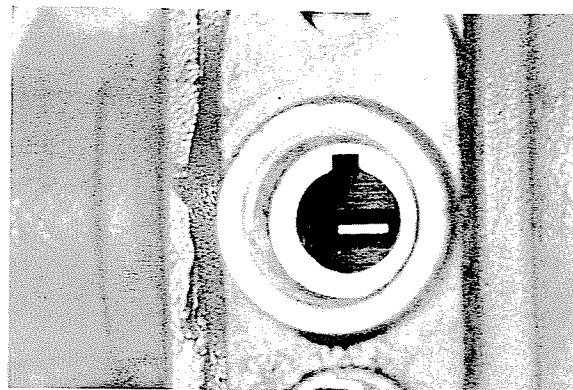

Reverse the position of the pin so the slot of the pin will fit over the timing tooth in the pump.



Install and secure the pin with the access plug.

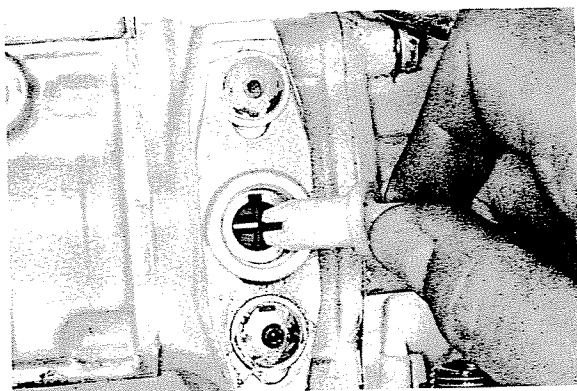

Make sure the o-ring seals for the fill orifice and pilot are correctly installed and are not damaged.

Lubricate the mounting flange with clean engine oil.

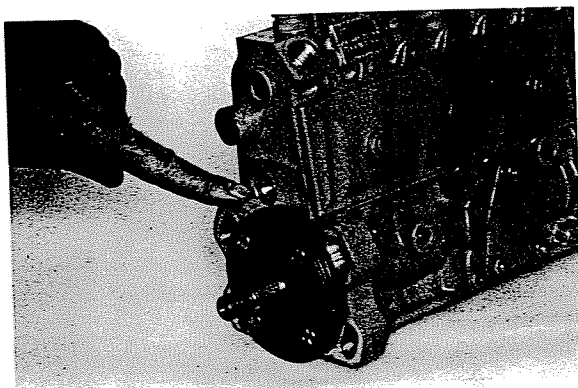

Slide the pump shaft through the drive gear and position the pump flange onto the mounting studs.

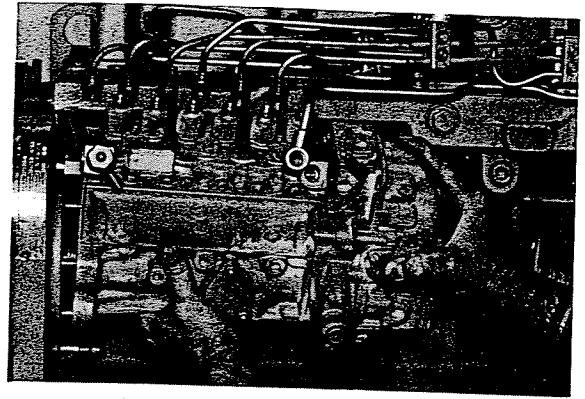

15 mm

Install the mounting nuts.

Torque Value: 43 N•m [32 ft-lbs]

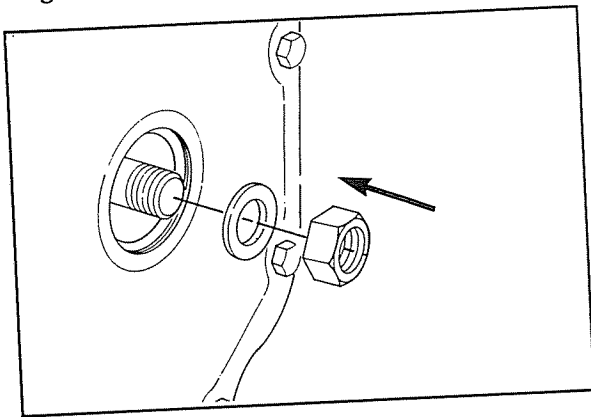
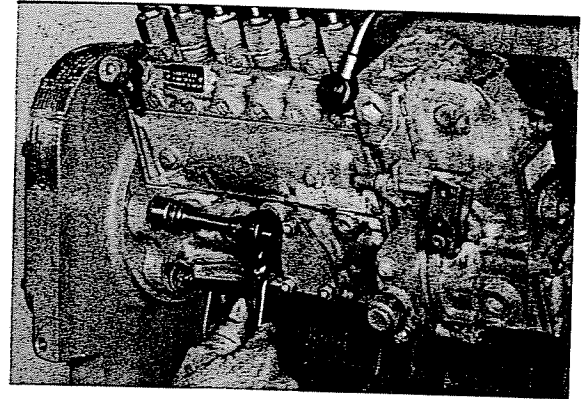

22 mm (PES6A Pump), 27 mm (PES6MW Pump)

Install the retaining nut and washer.

Torque Value: 10 to 15 N•m [7 to 11 ft-lbs]

Caution: Do not exceed the torque value given. This is not the final torque value for the retaining nut.

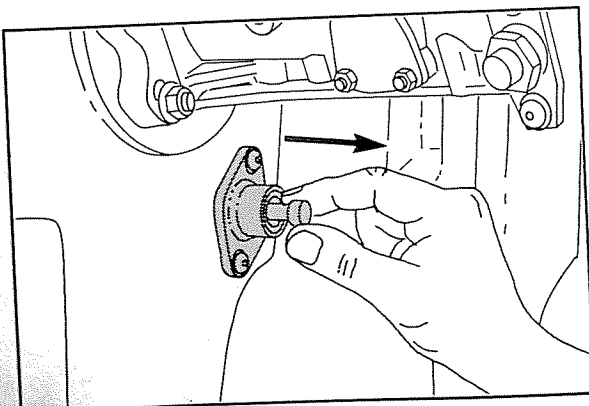

Disengage the engine timing pin.

24 mm

Remove the fuel pump timing pin plug. Reverse the position of the pin and install the pin, plug, and sealing washer.

Torque Value: 15 N•m [11 ft-lbs]

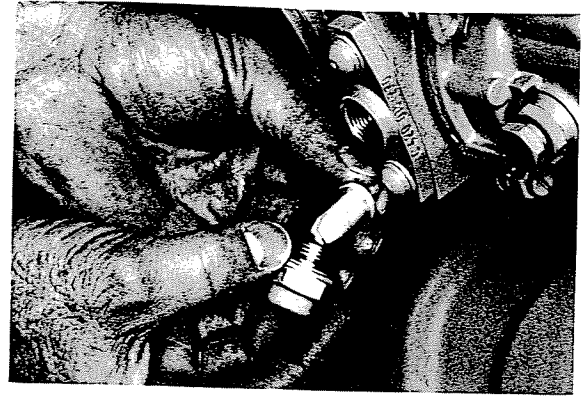

22 mm or 27 mm

Tighten the fuel pump drive nut.

Torque Value:

PES6A Pump, 93 N•m [68 ft-lbs]

PES6MW Pump, 105 N•m [77 ft-lbs]

Install the gear cover access cap hand tight.

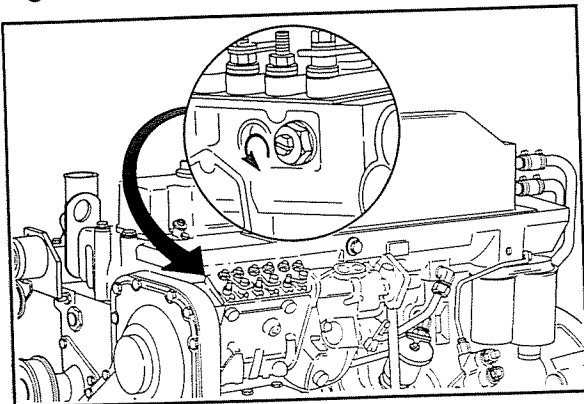
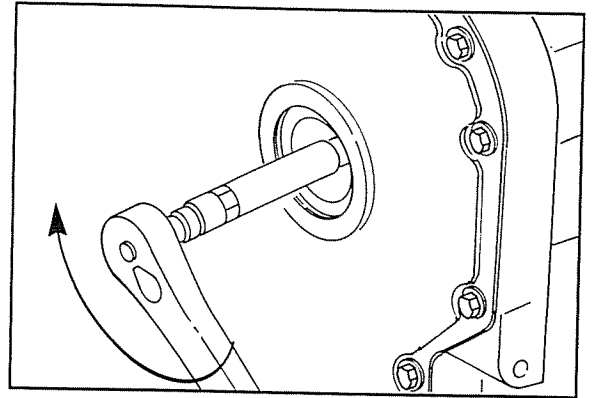

10 mm, 17 mm

Install the fuel lines, control linkage and fuel shut off solenoid.

The PES6MW pump **must** be vented after installation. Loosen the vent screw located near the front on the side nearest to the engine. Place the fuel control in the run position. Crank the engine so air can bleed from the pump. Then, tighten the vent screw.

NOTE: Earlier PES6MW pumps were not equipped with a vent screw. Remove the large plug from the location described above to vent the pump. PES6A pumps are self venting.

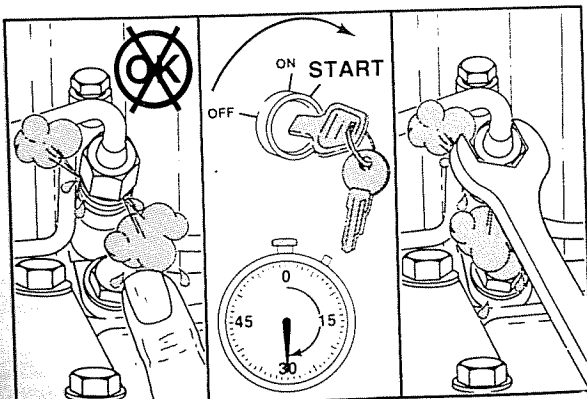

17 mm

Warning: The pressure of the fuel in the high pressure line is sufficient to penetrate the skin and cause serious bodily harm.

Vent the high pressure fuel lines. Loosen the fitting at the number 1 injector. Place the fuel control in the run position. Crank the engine so air can bleed from the fuel lines. Then, tighten the fitting.

Torque Value: 25 N•m [18 ft-lbs]

Vent each high pressure line separately until the engine runs smoothly.

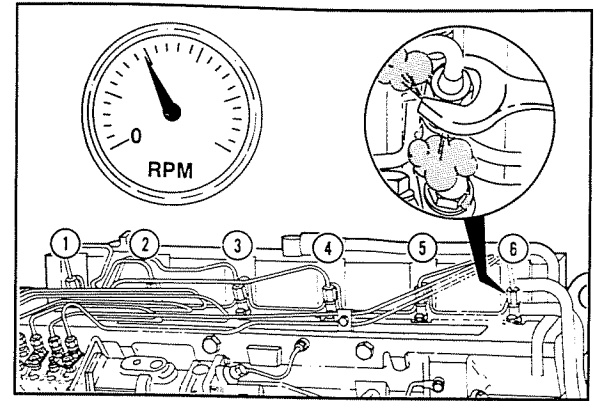

Idle Speed - Adjustment

Idle adjustment for industrial engines requires the setting of both the low idle screw (1) and the bumper spring screw (2).

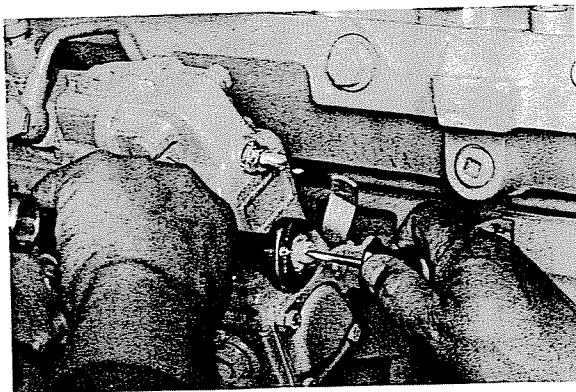
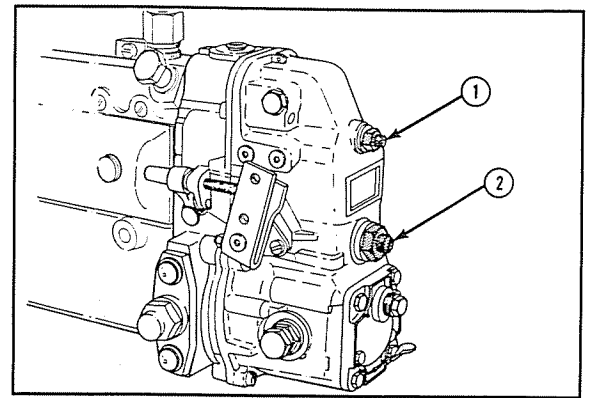

19 mm Screwdriver and Tachometer

First, loosen the locknut and back out the bumper spring screw until there is no change in engine speed.

Note: The speed should drop 20-30 rpm as the screw is backed out.

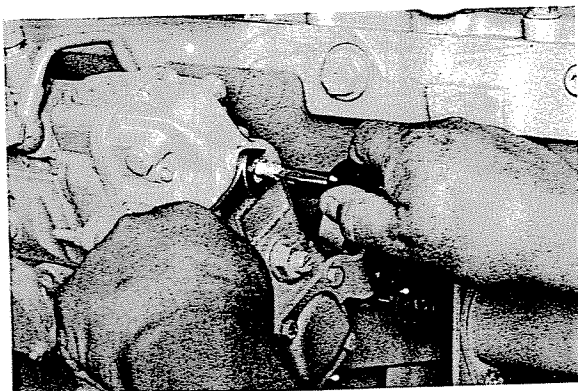

13 mm Screwdriver and Tachometer

Loosen the locknut and adjust the idle screw to 20-30 rpm less than the desired speed. Turn the screw counter-clockwise to decrease rpm; clockwise to increase rpm. Tighten the locknut.

Turn the bumper spring clockwise until the desired idle speed is obtained. Tighten the locknut.

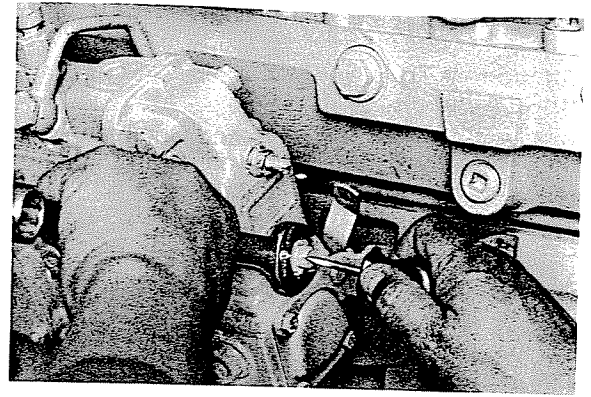

10 mm Screwdriver and Tachometer

Idle adjustment on automotive pumps requires setting of the stop screw.

Loosen the locknut and turn the screw counterclockwise to raise the rpm; clockwise to decrease the idle speed. Tighten the lockscrew.

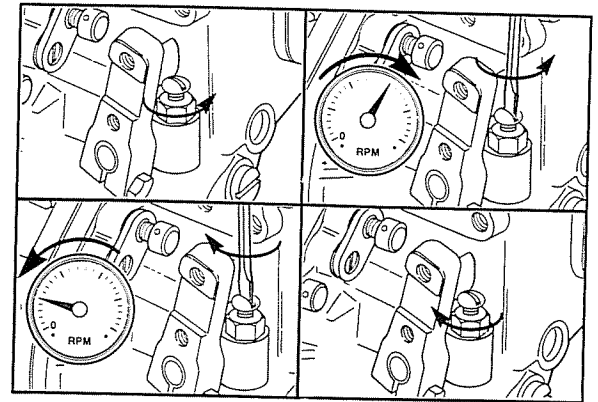

Air System Repair Summary Page 4-48

Air System Repair Summary

Component To Be Replaced	Tools
Air Crossover Tubing	8mm and Common Screwdriver and Torque Wrench
Intake Manifold Cover and Gasket	10mm Socket
Aftercooler and Gasket	8mm, 10mm Socket
Turbocharger and/or Gasket	10mm, 15mm, 16mm, 7/16-Inch Wrenches
Exhaust Manifold and/or Gasket	15mm Socket
Air Compressor	

Adjustment, Replacement and Repair C Series

Preparatory Steps*

Disconnect cold starting aid, if used, and air crossover tubing.

Disconnect Cold Starting aid if used, remove air crossover tube and drain coolant.

Disconnect intake and exhaust piping and remove crossover tubing.

Disconnect intake and exhaust piping, remove air crossover tube and remove the turbocharger.

Drain engine coolant.

*Removal of some chassis parts may be necessary to gain access to some engine components. Follow the equipment manufacturer's procedures and precautions for removing chassis parts.

Air System Repair

Air Crossover Tube - Replacement

8 mm or Screwdriver

Loosen the hose clamps and position the hose so the crossover tube can be removed.

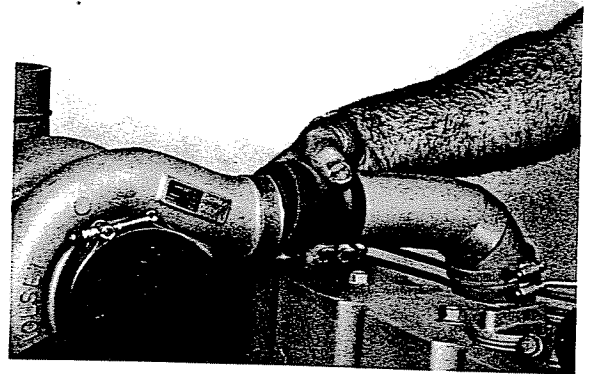

8 mm or Screwdriver

Use new hose and clamps as required to install the crossover tube.

Torque Value: 8 N•m [6 ft-lbs]

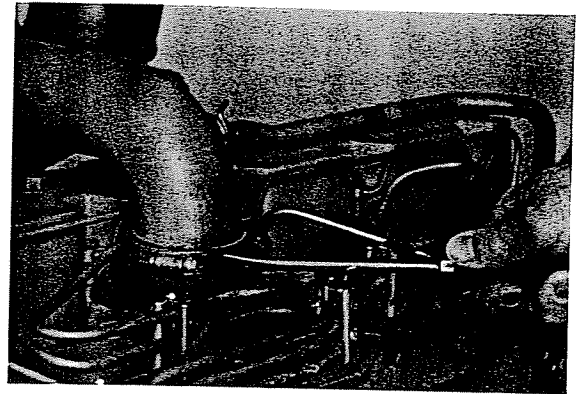

Intake Manifold Cover and Gasket - Replacement

Preparatory Steps:

- Disconnect the cold starting aid, if used.
- Remove the air crossover tube.

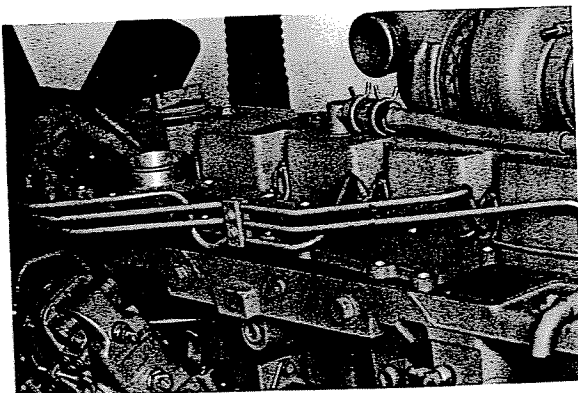

10 mm

Remove the manifold cover and gasket.

Clean the sealing surface.

Caution: Keep the gasket material and any other material out of the air intake.

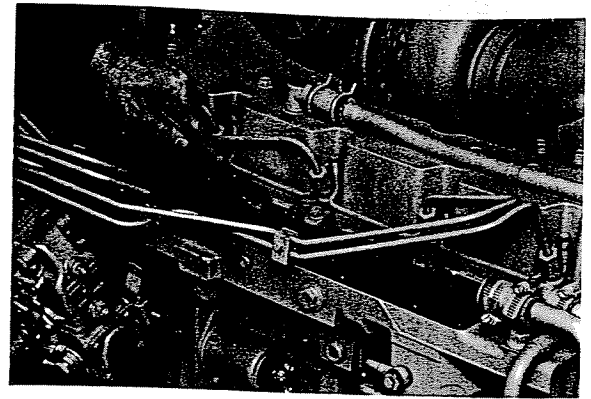

10 mm

Install the cover and a new gasket.

Torque Value: 24 Nm [18 ft-lbs]

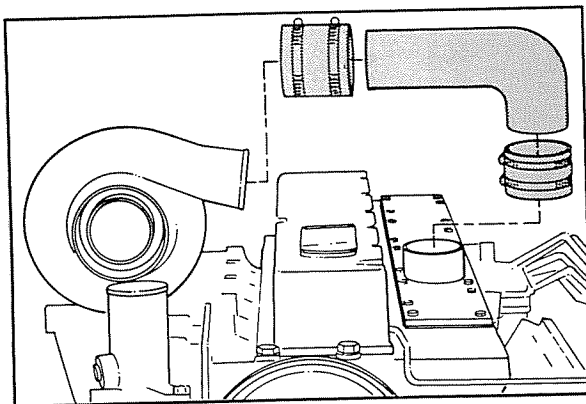
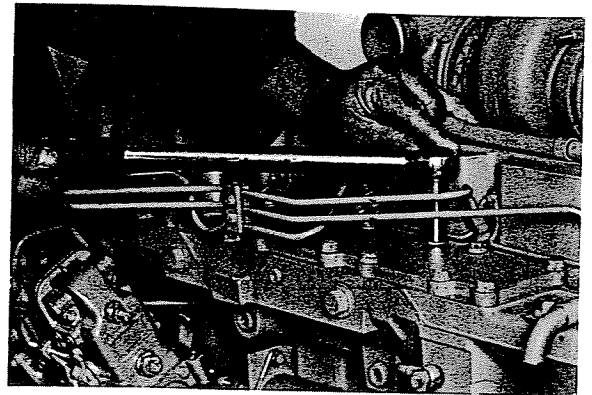

Assemble the intake piping and connect the cold starting aid if used.

Aftercooler and Gasket - Replacement Preparatory Steps:

- Disconnect the cold starting aid, if used.
- Remove the air crossover tube.
- Drain 2 litres (2.1 U.S. Quarts) of coolant.

Adjustment, Replacement and Repair
C Series

8 mm

Remove the coolant supply tube and the coolant return tube.

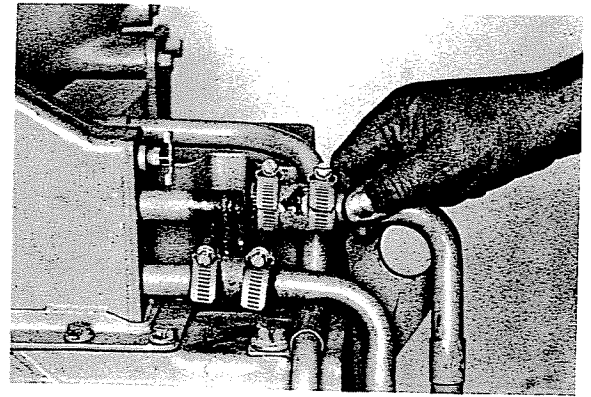

10 mm

Remove the aftercooler housing and gasket.

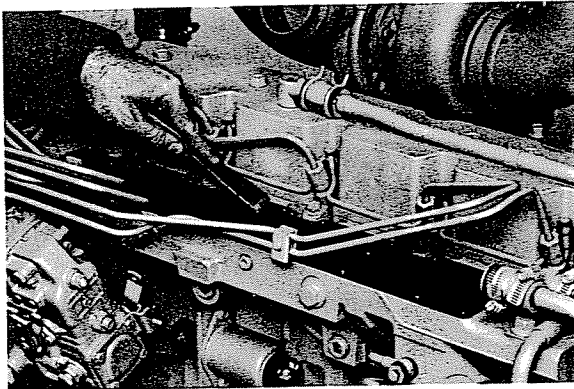
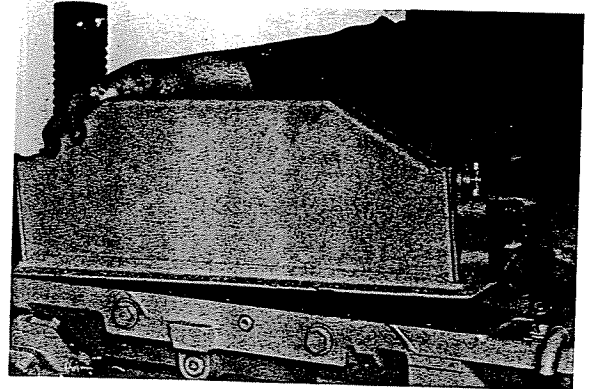

Clean the sealing surface.

Caution: Keep the gasket material and any other material out of the air intake.

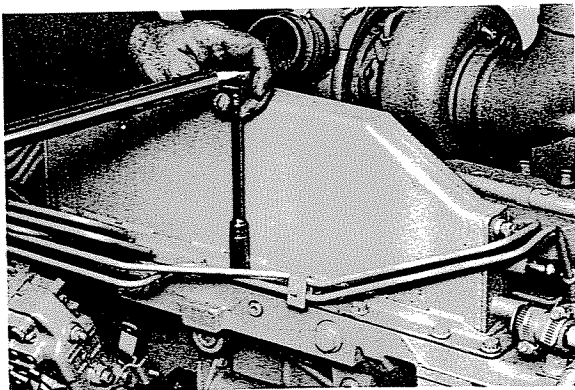

10 mm

Install the aftercooler housing and a new gasket.

Torque Value: 24 N•m [18 ft-lbs]

8 mm

Install the coolant supply tube (1) and coolant return tube (2). Install the air crossover tube.

Torque Value: 8 M•m [6 ft-lbs]

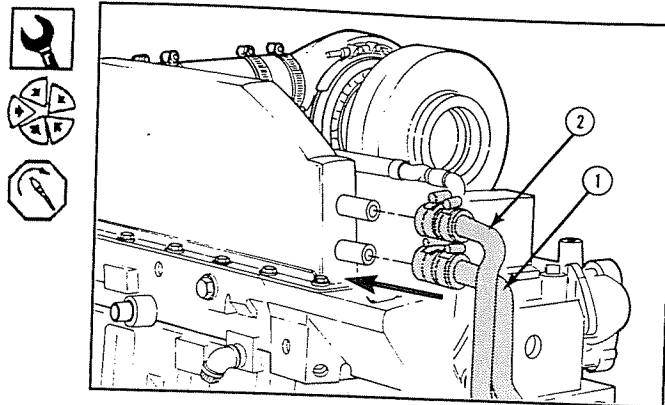

Caution: Be sure to open the engine and aftercooler vents to allow air to escape as the system is filled. Refer to Page 2-37.

Fill the coolant system with a mixture of 50% water and 50% ethylene-glycol type antifreeze.

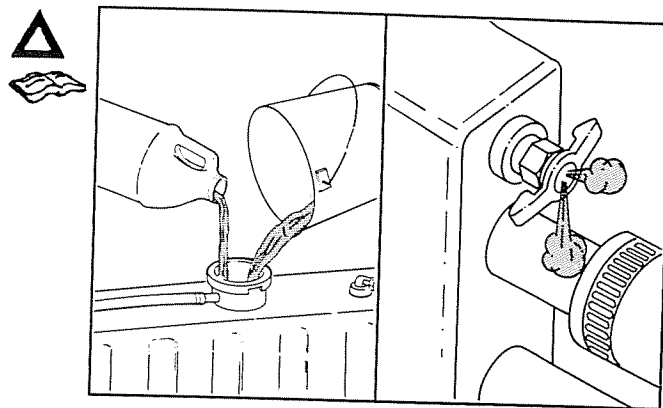

Turbocharger - Replacement

Preparatory Steps:

- Remove the air crossover tube.
- Disconnect the intake and exhaust piping.

10 mm

Remove the capscrews from the oil drain tube.

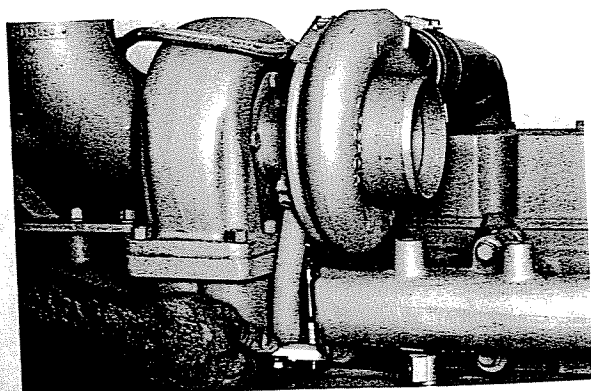

16 mm

Remove the oil supply line.

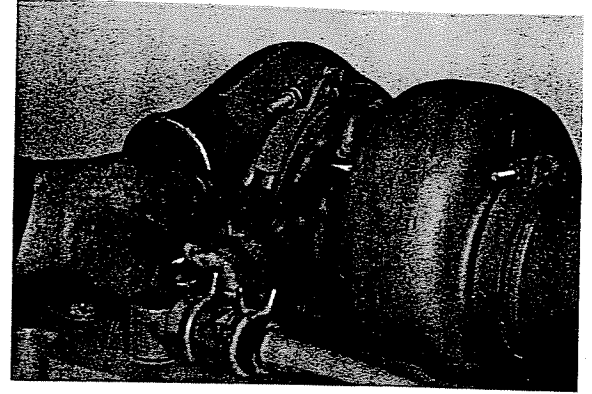

15 mm and 7/16-inch

Remove the exhaust clamp, turbocharger, and gasket.

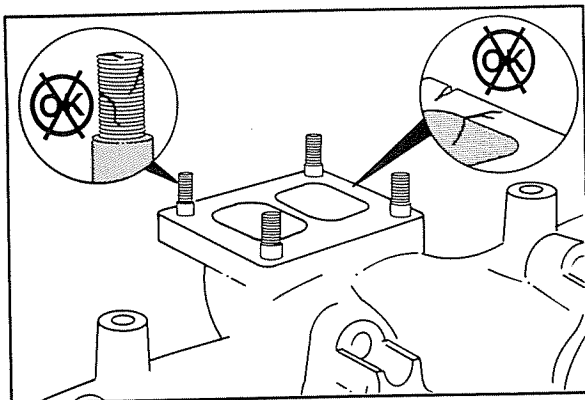
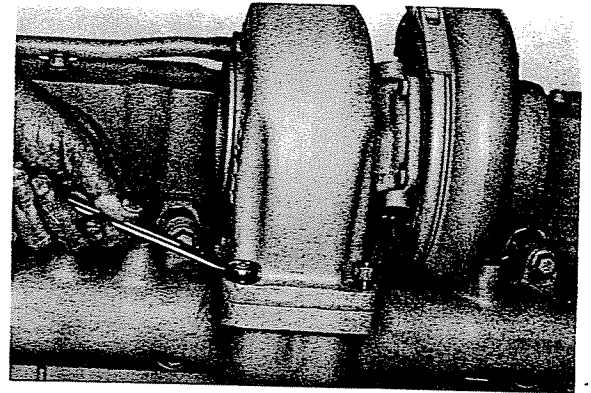

Clean the sealing surface. Inspect the sealing surface and mounting studs for damage.

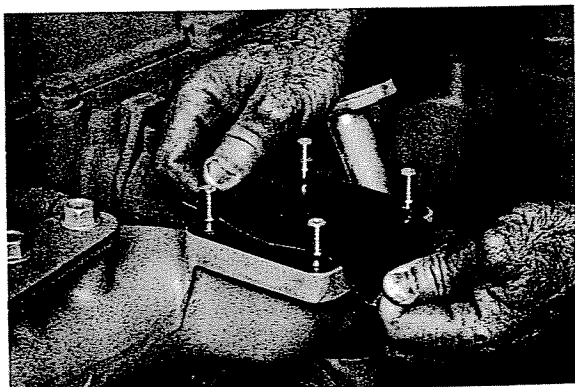

Caution: If the turbocharger is not to be immediately replaced, cover the opening to prevent any material from falling into the manifold.

Install a new gasket and apply anti-seize compound to the mounting studs.

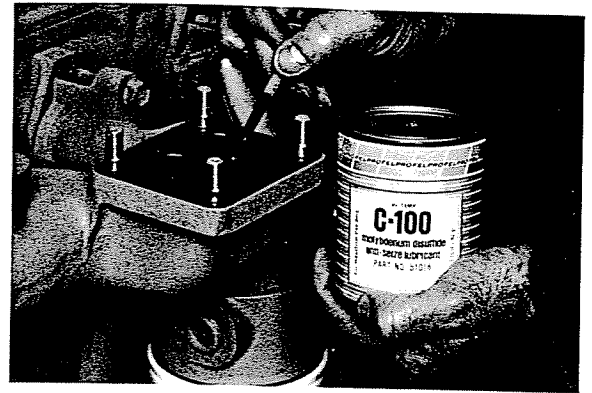

15 mm

Install the turbocharger and a new gasket.

Torque Value: 32 N•m [24 ft-lbs]

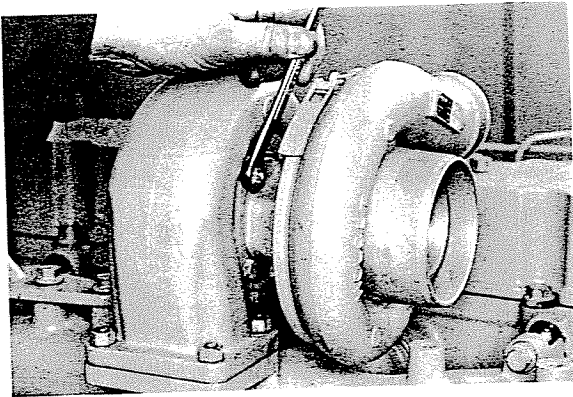
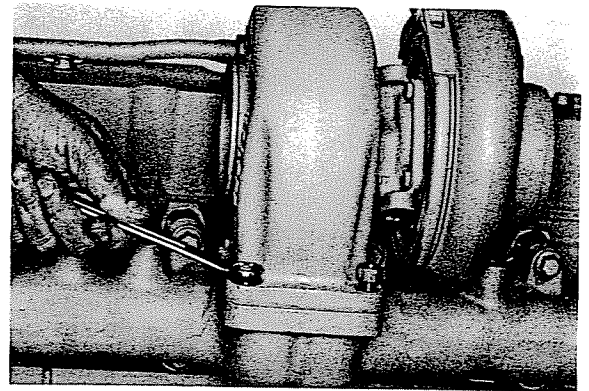

13 mm

If required, bend the lockplates back and loosen the turbine housing capscrews and position the bearing housing to install the turbocharger drain tube.

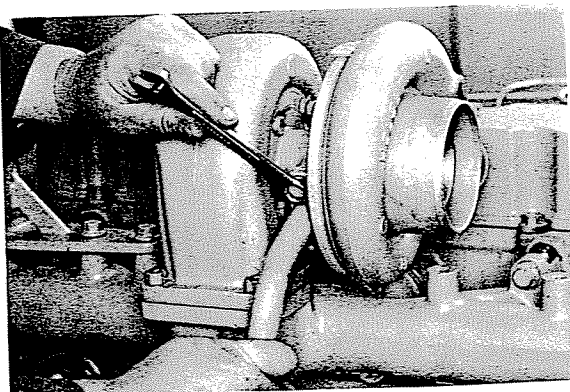

13 mm

Install the hose and clamps on the turbocharger drain tube loosely. Install the drain tube and gasket on the turbocharger.

Torque Value: 24 N•m [18 ft-lbs]

Position the turbocharger drain hose to connect the drain tubes; tighten the clamps.



13 mm, Punch, Hammer

If loosened, tighten the turbine housing capscrews. Bend the lockplates onto the flats to prevent loosening.

Torque Value: 11.3 N•m [100 inch-lbs]

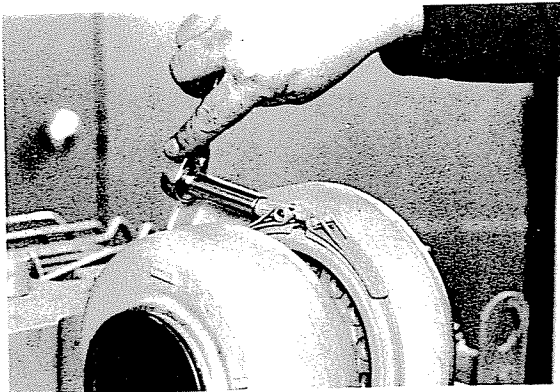
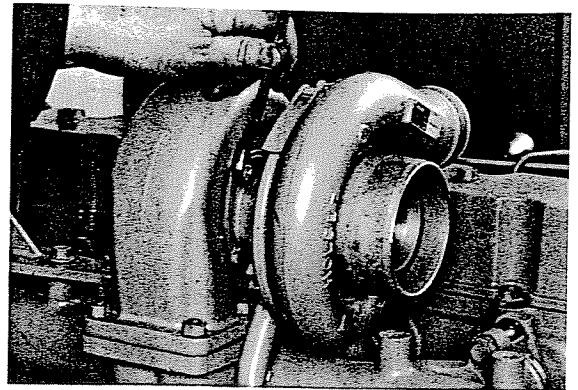

7/16 inch

If required, loosen the compressor housing and position the housing to align with the air crossover tube.

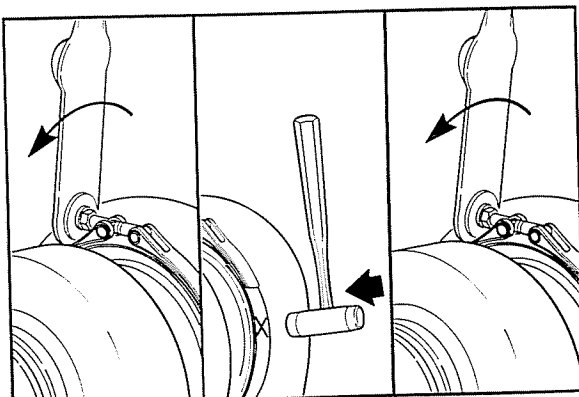

7/16 inch, Plastic Hammer

Tighten the band clamp to 5.7 N•m [50 inch-lbs]. Tap around the clamp with a plastic hammer and tighten again to 5.7 N•m [50 inch-lbs].

Caution: New turbochargers must be prelubricated before start-up.

Pour 50 to 60 cc [2 to 3 ounces] of clean engine oil into the oil supply fitting. Rotate the turbine wheel to allow the oil to enter the bearing housing.

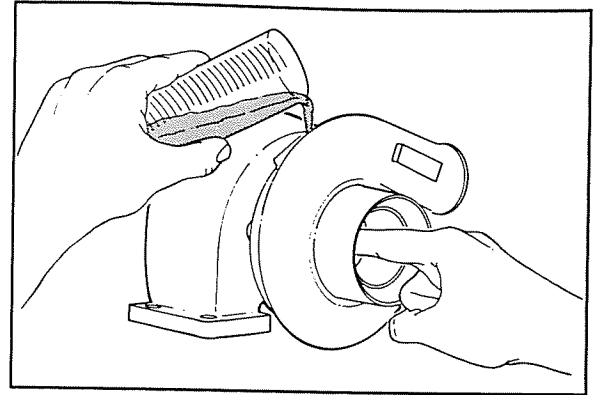

Install the exhaust outlet connection.

Do not tighten the two mounting capscrews until the band clamp has been tightened.

Torque Value: Band Clamp - 8 N•m [6 ft-lbs]
Capscrews - 43 N•m [32 ft-lbs]

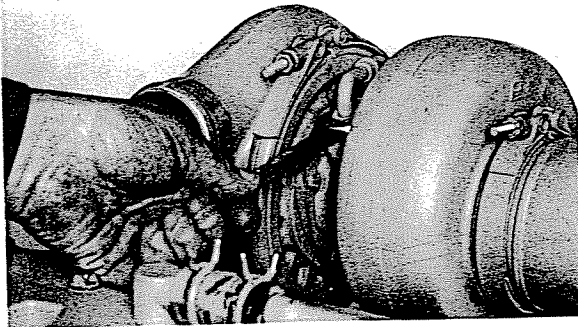
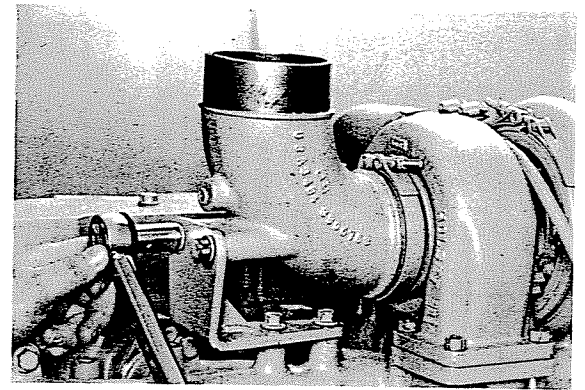

16 mm

Install the oil supply line.

Torque Value: 15 N•m [11 ft-lbs]

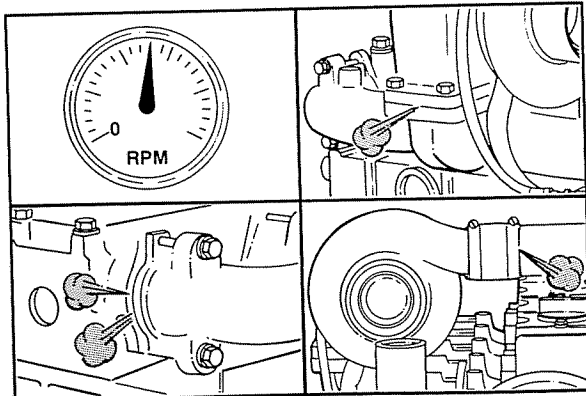

Install the air crossover tube, inlet and exhaust piping.
Operate the engine and check for leaks.



Exhaust Manifold and Gaskets - Replacement

Preparatory Steps:

- Remove the air crossover tube.
- Disconnect the air intake and exhaust piping.
- Remove the turbocharger, if used.

15 mm

Remove the exhaust manifold and gaskets.

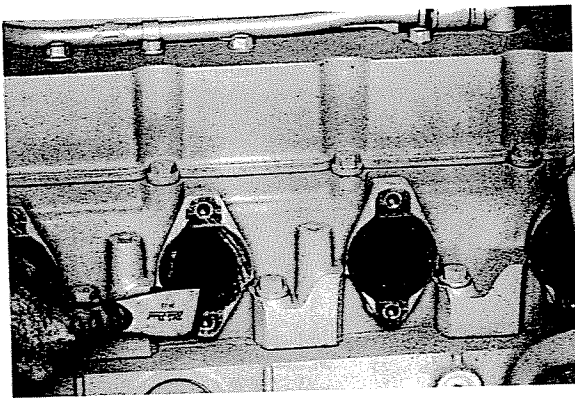
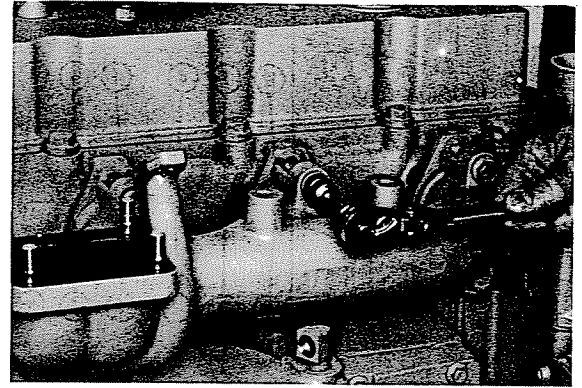

Clean the sealing surfaces.

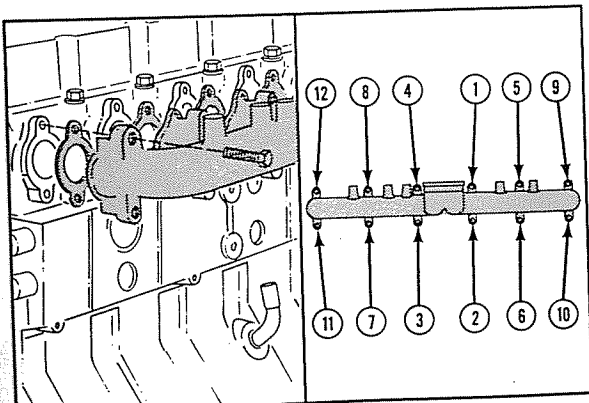

15 mm

Install the exhaust manifold and new gaskets.



Torque Value: 43 N•m [32 ft-lbs]



Follow the tightening sequence shown in the illustration. Then, follow the same sequence and tighten the cap-screws again to the same torque value.

Install the parts previously removed. Operate the engine and check for leaks.

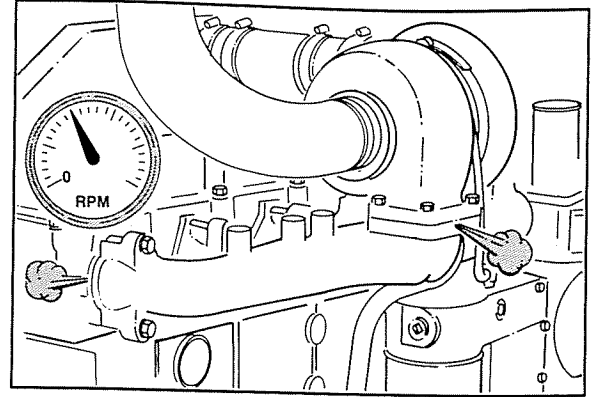

Air Compressor - Replacement

Preparatory Steps:

- Steam clean the air compressor and dry with compressed air.
- Drain the engine coolant.

Remove the air connections from the air compressor.

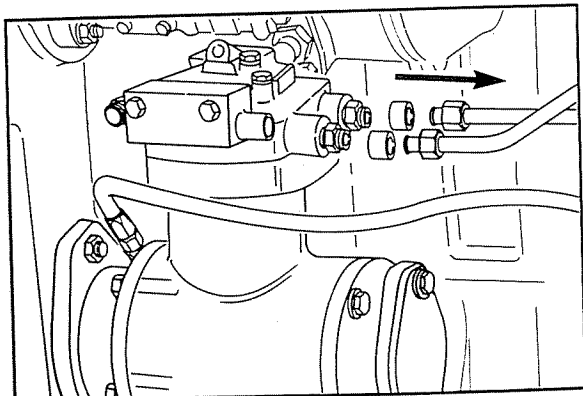
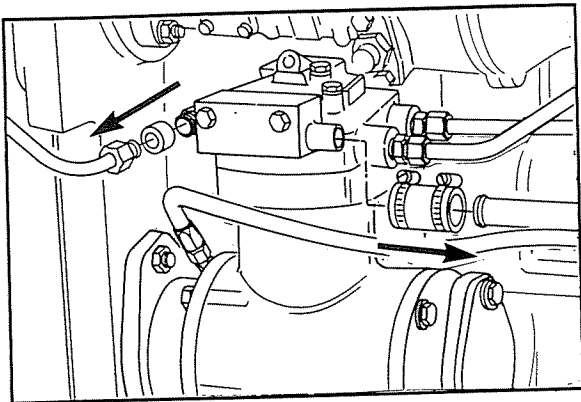

15/16 inch

Remove the coolant lines from the air compressor.

9/16 inch

Remove the oil supply line.

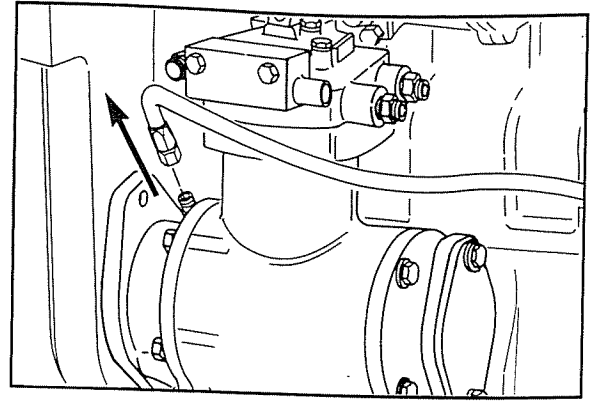

19mm, 15mm, 14mm

Remove the air compressor support bracket and cap-screws.

Remove the air compressor.

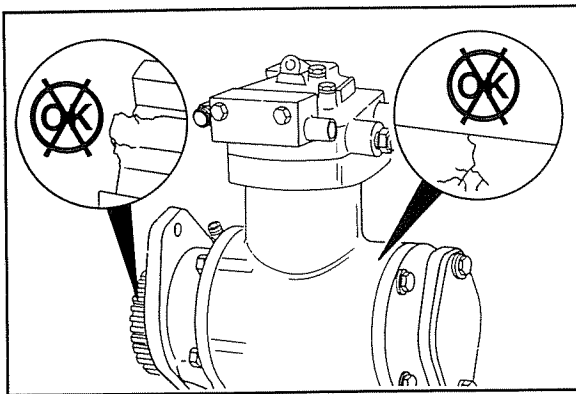
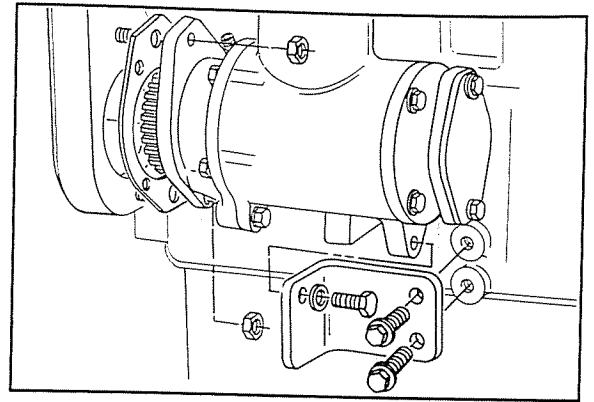

Visually inspect the compressor housing for cracks or damage.

Visually inspect the drive gear for cracks or damage.

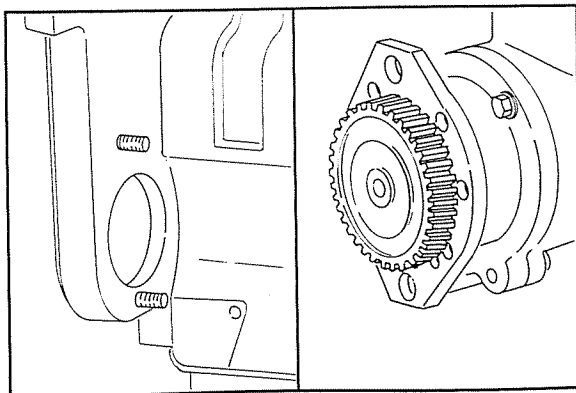

Be sure the gasket surfaces of the gear housing and air compressor are clean and not damaged.

Adjustment, Replacement and Repair C Series

19mm, 15mm, 14mm

Use a new gasket. Install the air compressor to the gear housing.

Tighten the nuts to 77 N•m [57 ft-lb] torque.

Install the air compressor support bracket.

Tighten the capscrews to 45 N•m [35 ft-lb] torque.

Caution: The gasket must be aligned as shown in the illustration to prevent blockage of the oil drain notch in the gear housing.

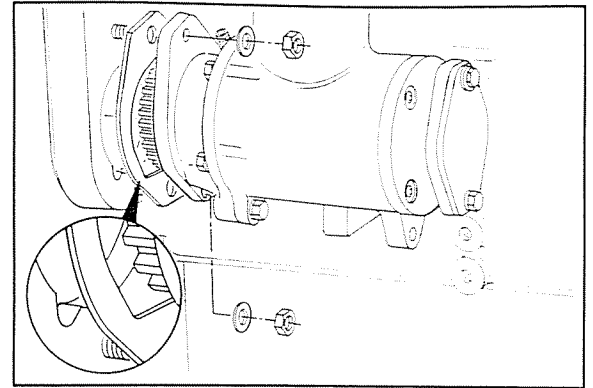

9/16 inch

Install the oil supply line.

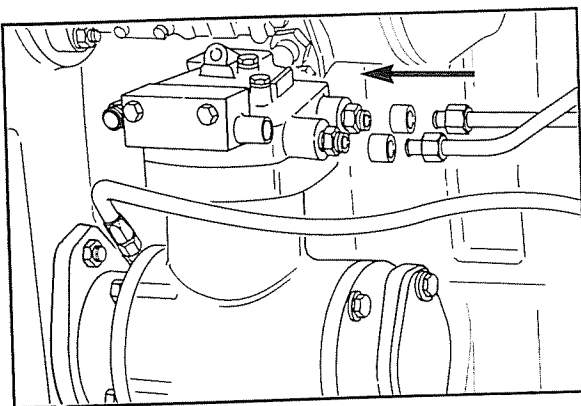
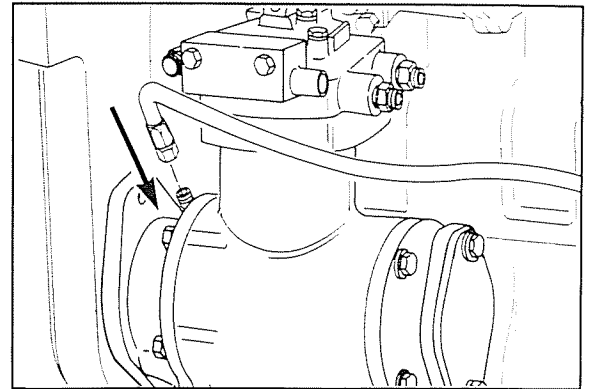

15/16 inch

Caution: If rubber grommets are used on the coolant lines, be sure they are installed carefully to prevent cuts or tears to the grommets which will cause coolant leaks.

Install the coolant lines.

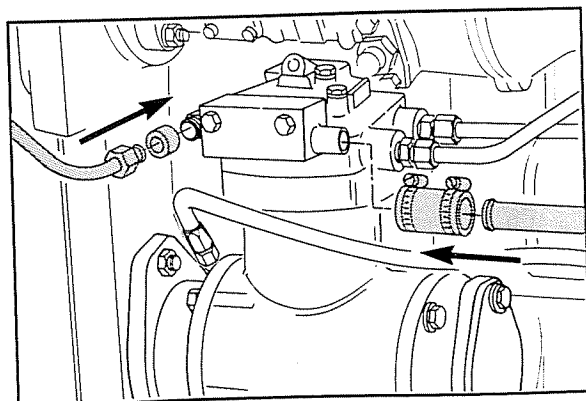

Install the air lines.

Fill the engine cooling system.

Operate the engine and check for leaks.

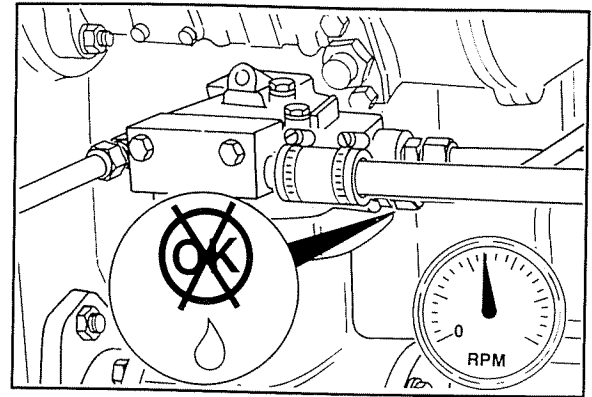

Lubricating System Repair Summary
Page 4-74

Lubricating System Repair Summary

Component To Be Replaced

Oil Pressure
Regulator Valve
and/or Spring

Oil Cooler
Element and/or
Gaskets

Oil Pan Suction
Tube and/or
Gaskets

Tools

Ratchet, 22mm Socket
and Torque Wrench

16mm Wrench, Ratchet,
10mm Socket and Torque
Wrench

Ratchet, 8mm, 10mm and
17mm Socket, Torque
Wrench

Adjustment, Replacement and Repair
C Series

Preparatory Steps

Clean debris.

Drain coolant.
Remove the oil filter.

Drain the oil.

Lubricating System Repair

Oil Pressure Regulator, Valve and Spring - Replacement

Preparatory Steps:

- Clean debris.

22 mm

Remove the plug and regulator valve.

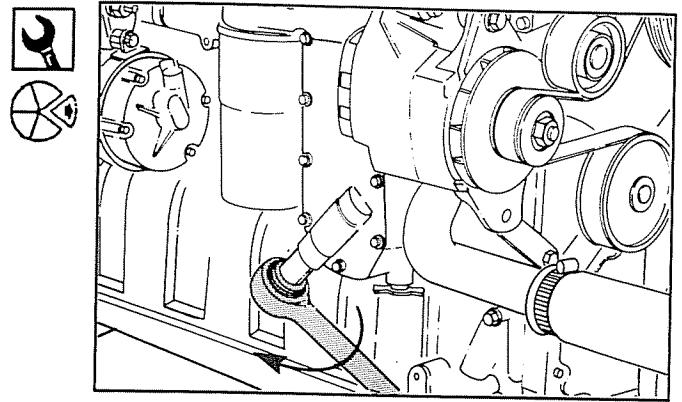

Lubricating System Repair Page 4-76

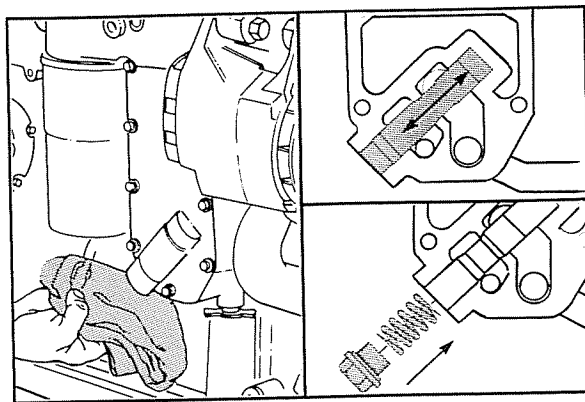

22 mm

Clean and inspect the bore and regulator valve before assembly.

The valve must move freely in the bore.

Install the regulator and spring.

Torque Value: 80 N•m [60 ft-lbs]

Oil Cooler Element and Gasket - Replacement

Preparatory Steps:

- Drain the coolant.
- Remove the oil filter.

Clean all debris from around the oil cooler.

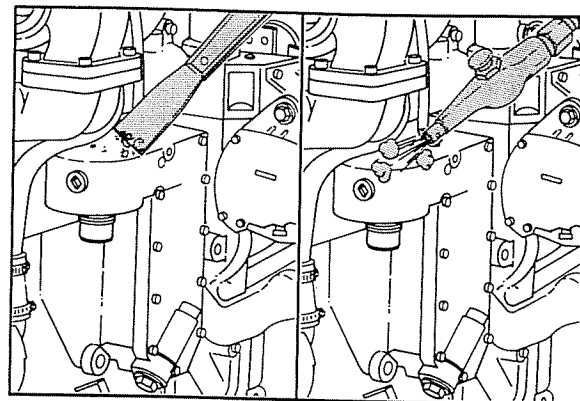

16 mm

Remove the turbocharger oil supply line from the oil filter head.

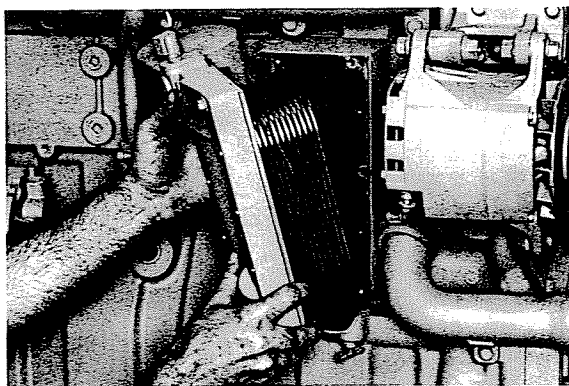
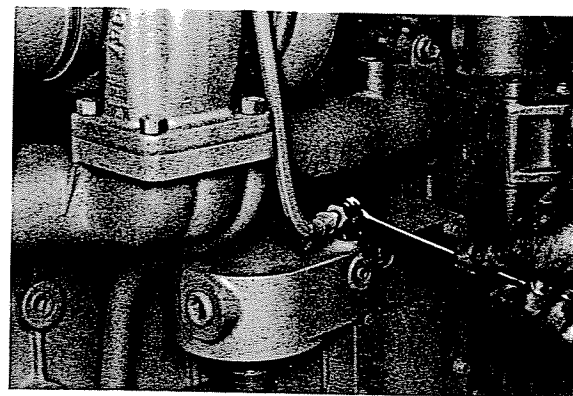

10 mm

Remove the oil cooler cover, element and gaskets.

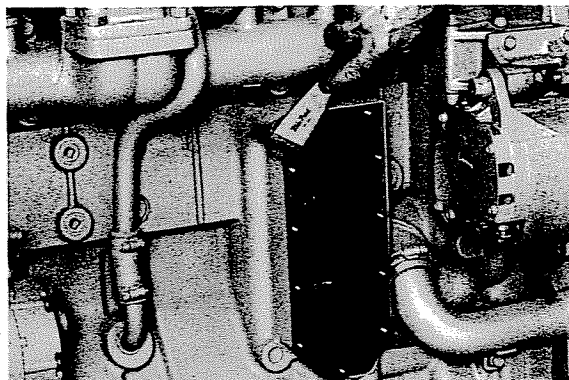

Clean the sealing surfaces.

Adjustment, Replacement and Repair
C Series

10 mm

Assemble the oil cooler gasket, element, cooler cover gasket and cooler cover to the cylinder block.

Be sure to remove the shipping plugs from the new cooler element.

Torque Value: 24 N•m [18 ft-lbs]

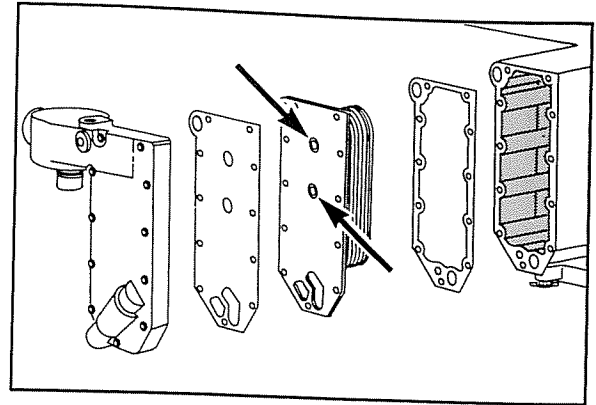

Lubricating System Repair
Page 4-79

16 mm

Connect the turbocharger oil supply line.

Torque Value: 15 N•m [11 ft-lbs]

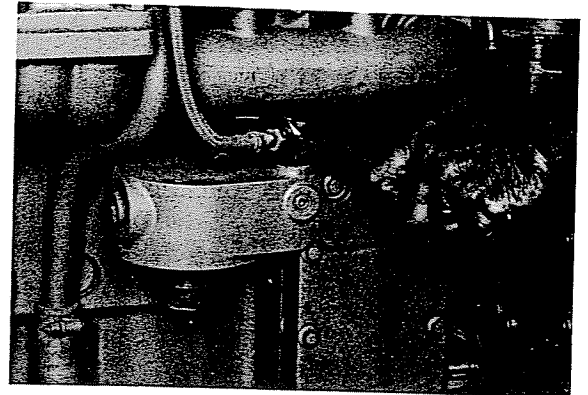

Lubricating System Repair
Page 4-80

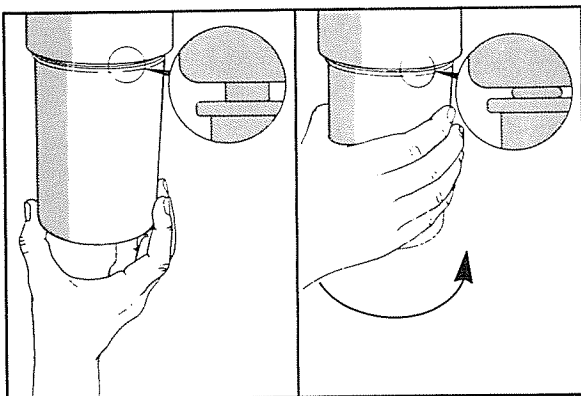

Install a new oil filter.

Follow the manufacturer's instructions for tightening.

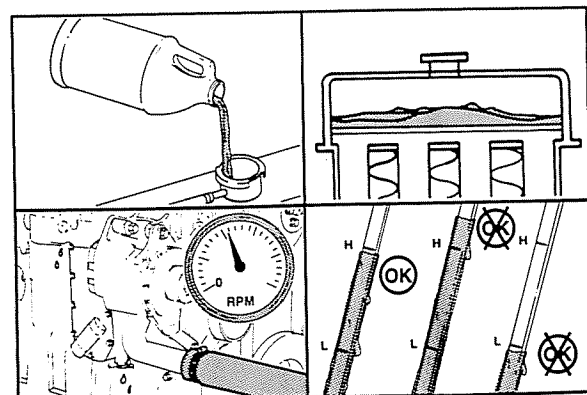

Caution: Be sure to open the engine and aftercooler vents to allow air to escape as the system is filled. Refer to Page 2-37.



Fill the coolant system and operate the engine to check for leaks.



Stop the engine and check the coolant and oil level.

Adjustment, Replacement and Repair
C Series

Oil Pan, Suction Tube and Gaskets - Re- placement

Preparatory Step:

- Drain the oil.

10 mm

Remove the oil pan.

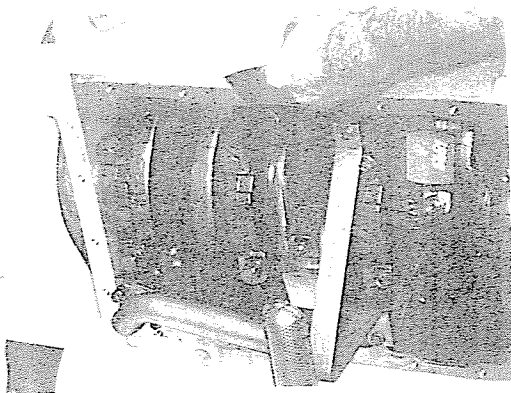
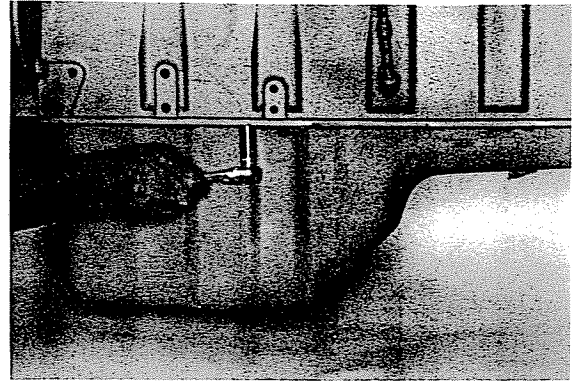

Clean the sealing surface.

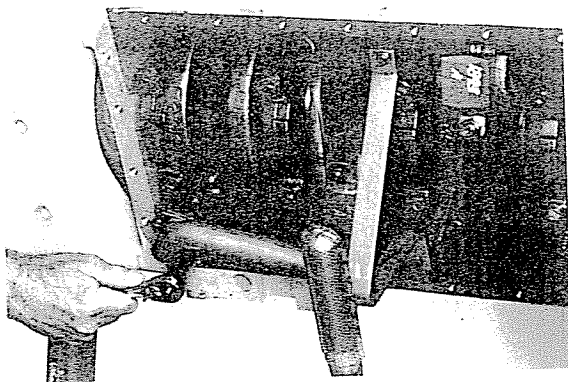

8 mm

Remove the suction tube and gasket.



Clean the sealing surface.



Adjustment, Replacement and Repair
C Series

8 mm

Install the suction tube and gasket. Be sure to connect the support bracket to the tube.

Torque Value: 9 N•m [7 ft-lb]

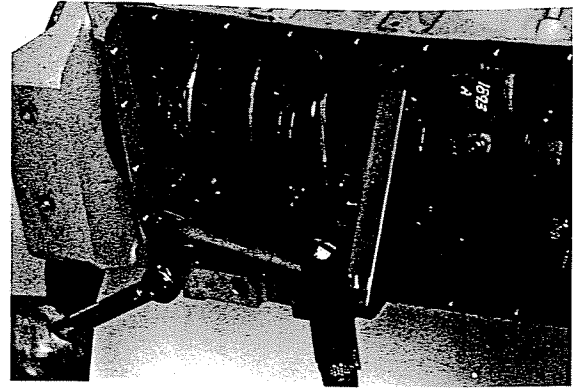

Be sure to fill the joints between the pan rail, gear housing and rear cover with Number 2 Permatex.

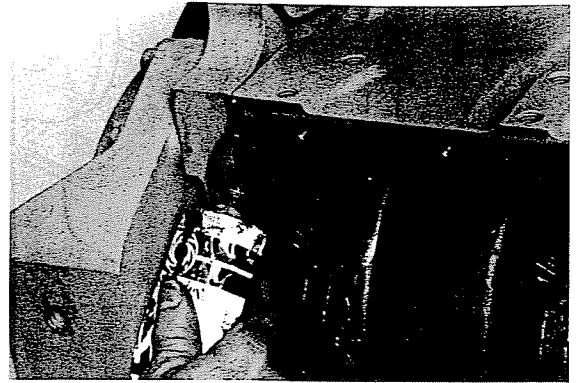

Lubricating System Repair
Page 4-84

Adjustment, Replacement and Repair
C Series

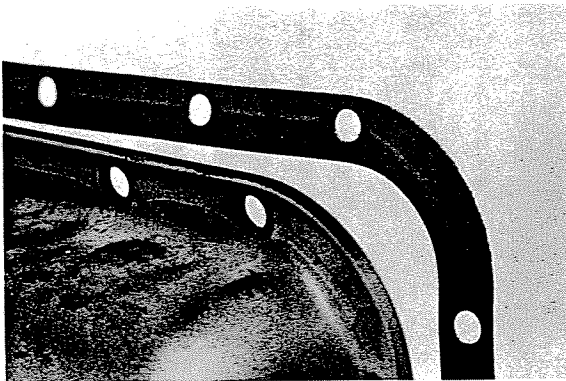

10 mm

Apply K & W copper coat to both sides of the pan gasket.

Install the oil pan and new gasket. Be sure the raised bead on the gasket is toward the oil pan.

Torque Value: 24 N•m [18 ft-lbs]

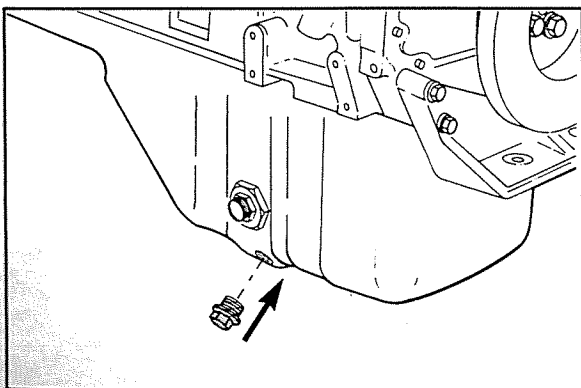

17 mm

Install the oil pan drain plug.

Torque Value: 80 N•m [60 ft-lbs]

- Fill the oil pan with clean engine oil.
- Operate the engine and check for leaks.
- Stop the engine and check the oil level with the dipstick.

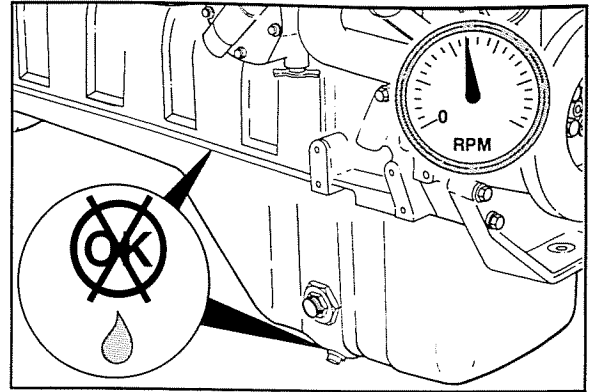

Crankshaft Seal Repair Summary
Page 4-86

Crankshaft Seal Repair Summary

Component To
Be Replaced

Front Crankshaft
Seal

Tools

Ratchet, 18mm Socket,
1/4" Drill Motor, 3mm
Drill, Slide Hammer fitted
with #10 Sheet Metal Screw,
Hammer, and Torque Wrench

Preparatory Steps

Remove drive belt
Remove fan

Rear Seal

Ratchet, 19mm Socket,
1/4" Drill Motor, 3mm
Drill, Slide Hammer fitted
with #10 Sheet Metal Screw,
Hammer, and Torque Wrench

Remove Transmission and Clutch
Remove Starter

Adjustment, Replacement and Repair
C Series

Crankshaft Seal Repair

Front Crankshaft Seal - Replacement

Preparatory Step:

- Remove the drive belt.

18 mm

Remove the vibration damper and pulley.

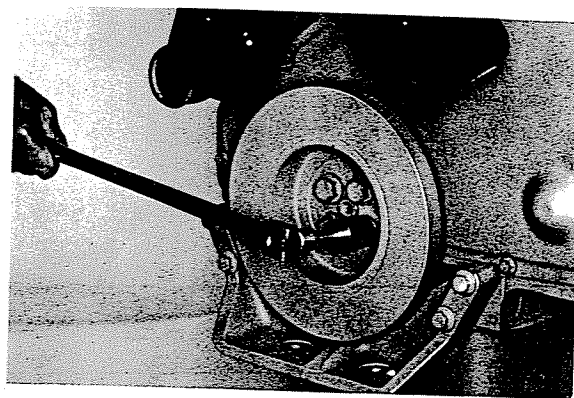

Crankshaft Seal Repair
Page 4-88

Adjustment, Replacement and Repair
C Series

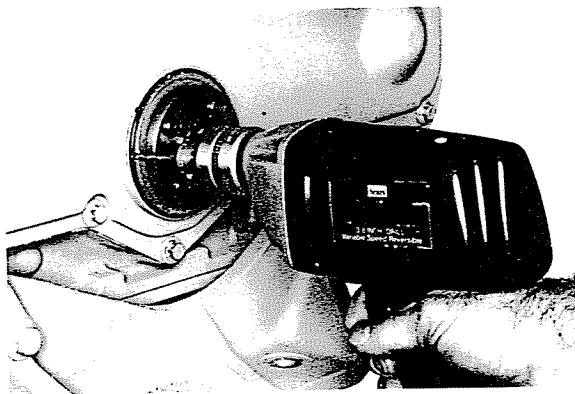

3 mm Drill, 1/4 Inch Drill Motor

Drill two holes, 180 degrees apart, into the metal part of the seal.

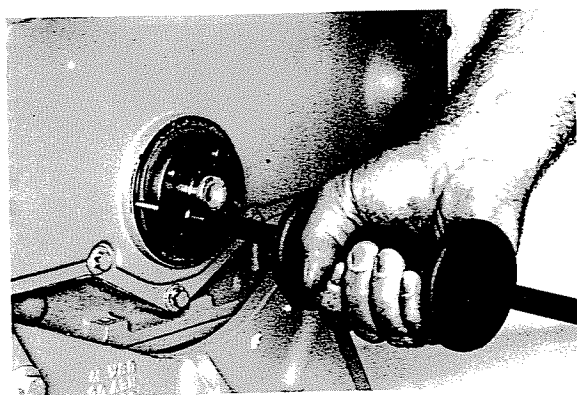

No. 10 Sheet Metal Screw, Slide Hammer

Use the screw and slide hammer to remove the seal.



Caution: The seal lip and the sealing surface on the crankshaft must be clean and free from all oil residue to prevent seal leaks.

Thoroughly clean the seal area of the crankshaft.



Install the pilot from the seal replacement kit onto the crankshaft. Apply a coat of Loctite 277 to the outside diameter of the seal. Push the seal onto the pilot and into the bore in the front cover. Remove the pilot.

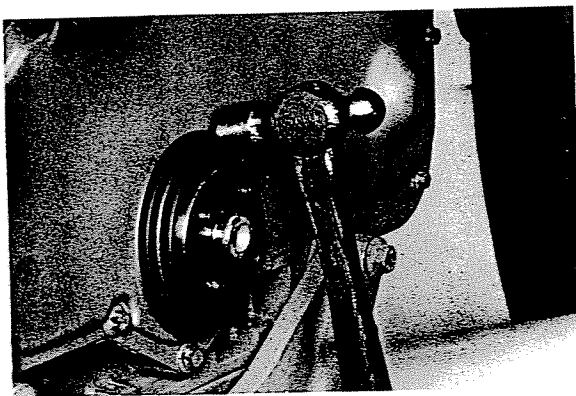
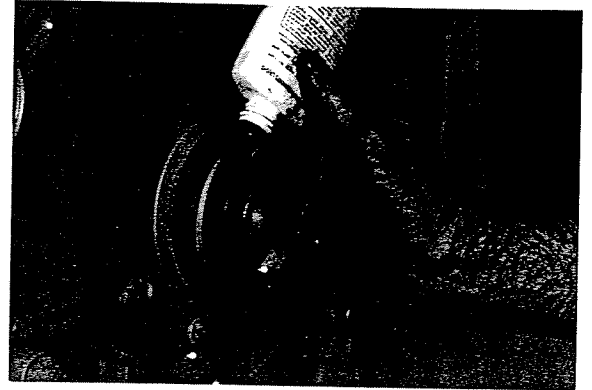

Use the installation tool from the seal replacement kit to install the seal to the correct depth in the bore.

To prevent damage to the seal, hit the installation tool alternately at the 12, 3, 6 and 9 o'clock positions.

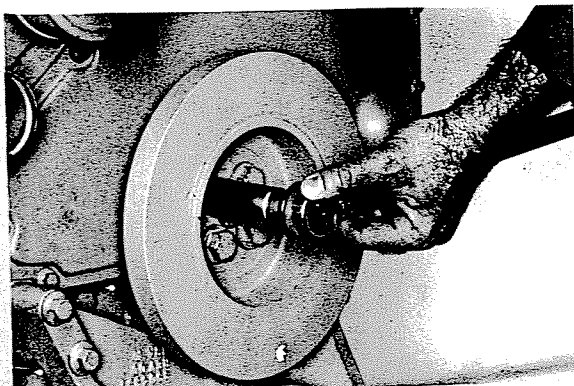

18 mm

Install vibration damper and pulley.



Torque Value:

Combination Vibration Damper and Pulley
200 N•m [148 ft-lbs]

Separate Pulley to Vibration Damper
77 N•m [57 ft-lbs]



Install the drive belt. Operate the engine and check for leaks.

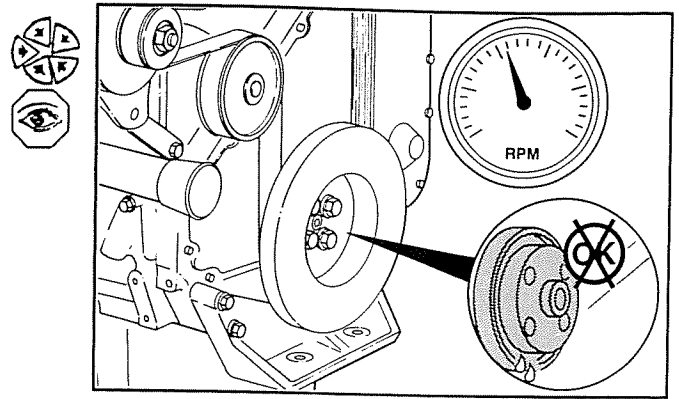

Rear Crankshaft Seal - Replacement

Preparatory Steps:

- Remove the transmission and clutch.
- Remove the starter.

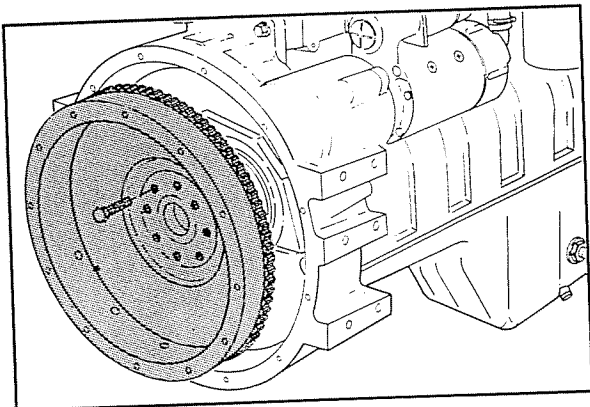

19 mm
Remove the flywheel.

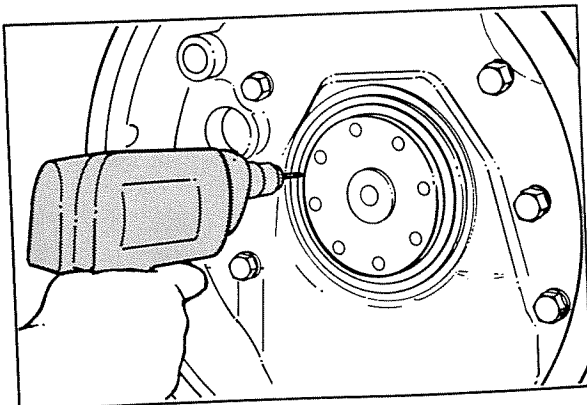

3 mm Drill, 1/4 Inch Drill Motor
Drill two holes, 180 degrees apart, into the metal part of the seal.

No. 10 Sheet Metal Screw, Slide Hammer

Use the screw and slide hammer to remove the seal.

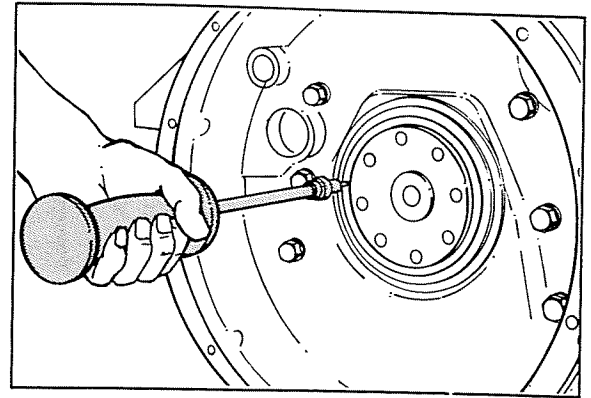

Caution: The seal lip and sealing surface of the crankshaft must be clean and free from all oil residue to prevent seal leaks.

Thoroughly clean the seal area of the crankshaft.

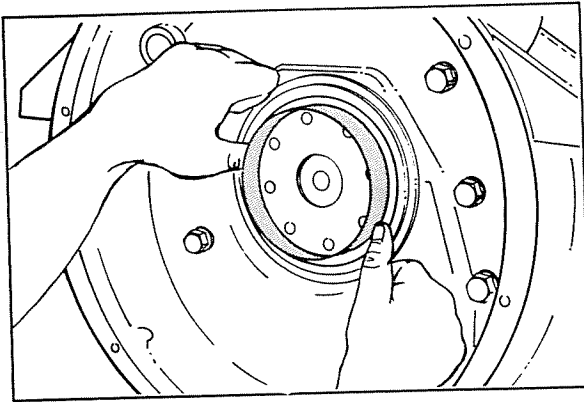
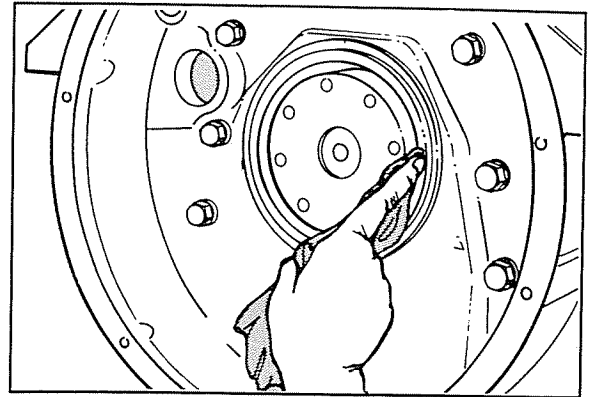

Install the pilot from the seal replacement kit onto the crankshaft. Apply a coat of mild soap to the O.D. of the seal. Push the seal onto the pilot and into the bore of the housing. Remove the pilot.



Do not use Loctite on the rear crankshaft seal.

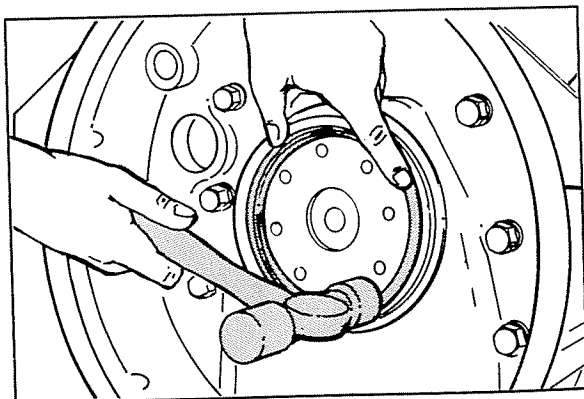

Use the installation tool from the seal replacement kit to install the seal to the correct depth. To prevent damage to the seal, hit the installation tool alternately at the 12, 3, 6 and 9 o'clock positions.

Note: Make sure the seal is completely installed into the rear housing.

**Adjustment, Replacement and Repair
C Series**

19 mm

Install the flywheel. Tighten the capscrews in sequence as shown in the illustration.

Torque Value: 137 N•m [101 ft-lbs]

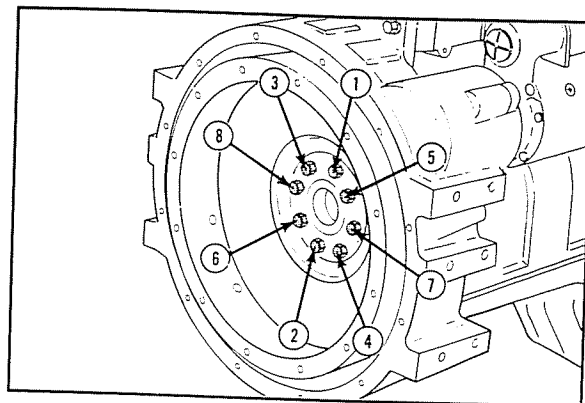

Install the clutch, transmission and starter. Operate the engine and check for leaks.

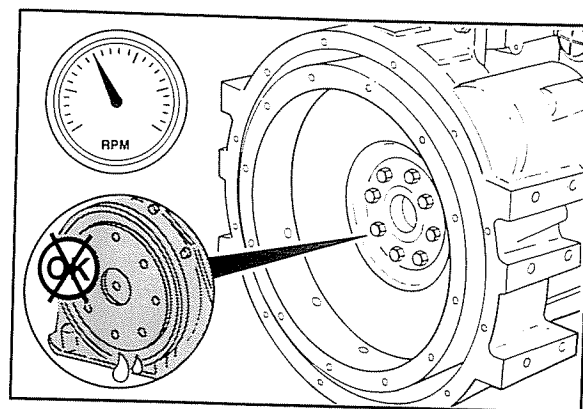

**Electrical System Repair Summary
Page 4-96**

**Adjustment, Replacement and Repair
C Series**

Electrical System Repair Summary

Component To Be Replaced

Tools

Preparatory Steps

Starting Motor

Ratchet, 16mm Socket, 19mm Wrench, and Torque Wrench

Disconnect ground cable to battery.

Alternator

Ratchet, 8mm, 13mm and 17mm Socket and Torque Wrench, 1/2 inch Square Drive Breaker Bar

Disconnect ground cable to battery and remove drive belt.

Electrical System Repair

Starting Motor - Replacement

Preparatory Steps:

- Disconnect the ground cable from the battery.
- Identify each electrical wire with a tag indicating location.

19 mm

Remove the battery cable from the solenoid.

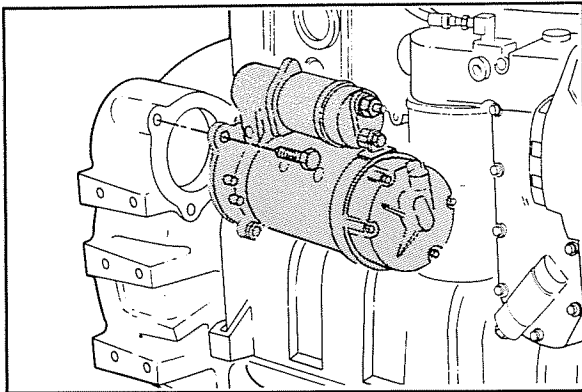
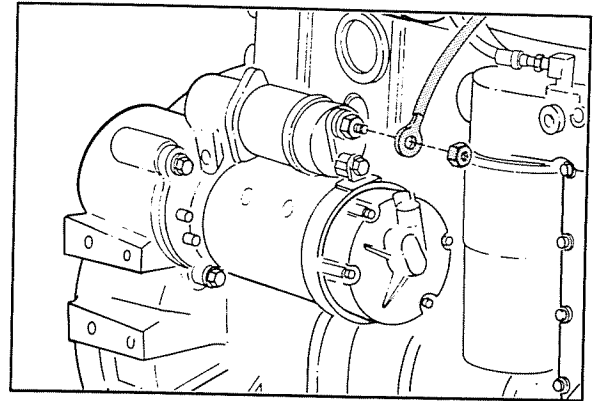

16 mm

Remove the starting motor.

Install the starting motor in the reverse order of removal.

Torque Value: 77 N•m [57 ft-lbs]

Alternator - Replacement

Preparatory Steps:

- Disconnect the ground cable from the battery terminal.
- Identify each electrical wire with a tag indicating location.

19 mm

Remove the capscrew from the alternator link.

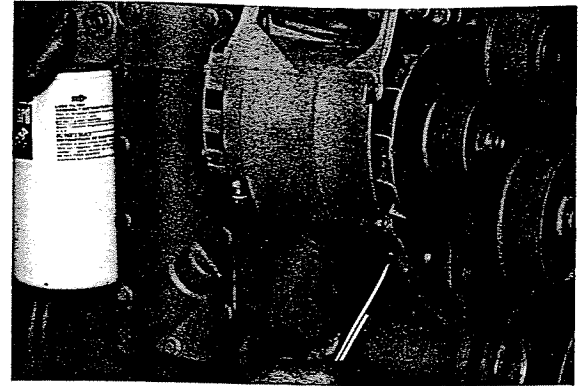

18 mm, 19 mm

Remove the alternator mounting capscrews and nuts.

Remove the alternator.

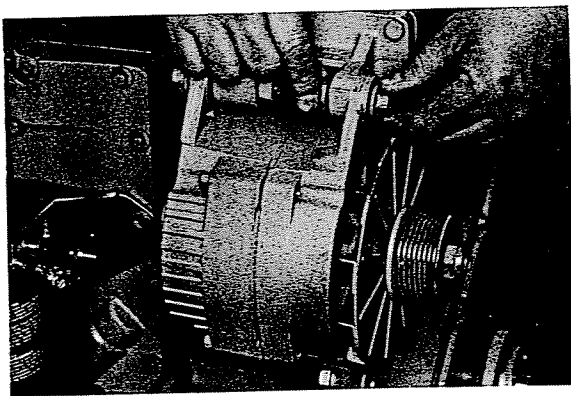
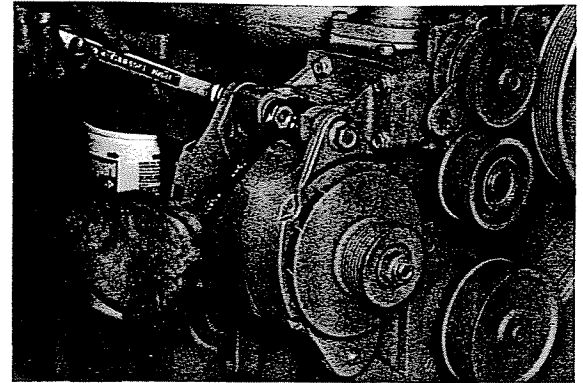

Position the alternator on the bracket and secure it with the mounting capscrews.

Do not tighten at this time.

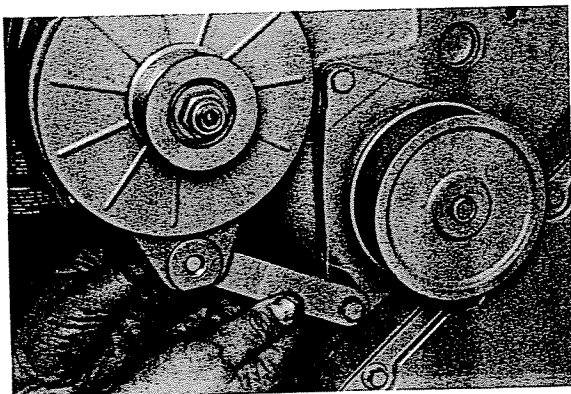

Connect the alternator link to the alternator. Finger tighten.

Caution: Make sure the alternator link is properly positioned for correct belt alignment.

15, 18, 19 mm

Tighten the alternator mounting capscrew.

Torque Value:

A = 43 N•m [32 ft-lbs]

B = 24 N•m [18 ft-lbs]

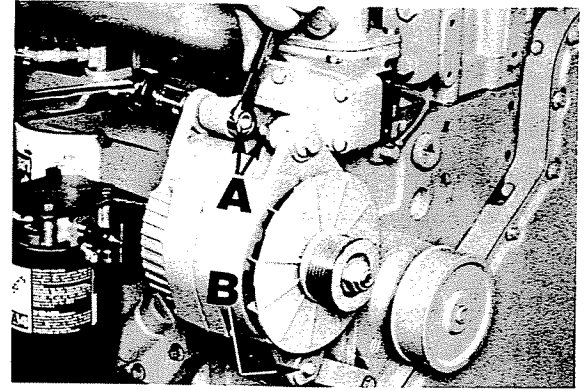

Section 5 - Specifications and Torque Values

Table of Contents

Subject	Page
Engine Component Torque Value	5-2
Sealants	5-7
Lubricants.....	5-8
Engine Specifications	5-10
Capscrew Markings and Torque Values.....	5-14
Lubricant, Fuel and Coolant.....	5-16

Engine Component Torque Value

Socket Or Wrench Size MM (Inch)		Torque ± N•m	(Ft-lb)
10	Aftercooler Mounting	24 ± 3	(18)
8	Aftercooler Water Hose Clamp.....	5 ± 1	(4)
(15/16)	Air Compressor Gear Nut	125 ± 13	(93)
18	Air Compressor Mounting Nut.....	77 ± 7	(57)
19 & 13	Air Comp to Brace.....	43 ± 4	(32)
24	Air Comp Water Line	35 ± 10	(25)
(15/16)	Alternator Pulley Nut.....	80 ± 8	(59)
8 Allen	(Alternator Shaft)		
13	Alternator Link	24 ± 3	(18)
13	Alternator Mounting Bolt (10-15 SI).....	43 ± 4	(32)
10	Alternator Support (Upper).....	24 ± 3	(18)
13	Belt Tensioner to Bracket	43 ± 4	(32)
5 Allen	Belt Tensioner Bracket to Block.....	24 ± 3	(18)
13	Cam Thrust Plate.....	24 ± 3	(18)
12	Connecting Rod.....	40 ± 5	(30)
	80 ± 5	(60)
	120 ± 5	(88)
18	Crankshaft Damper.....	200 ± 12	(148)

Engine Component Torque Value (Continued)

Socket Or Wrench Size MM (Inch)		Torque ± N•m	(Ft-lb)
8	Crossover Clamp	5 ± 1	(4)
15	Exhaust Manifold	43 ± 4	(32)
16	Exhaust Outlet Pipe Mounting	43 ± 4	(32)
11	Exh Outlet Pipe, "V" Band Clamp.....	5 ± 1	(4)
10	Fan Bracket Mounting	24 ± 3	(18)
13	Fan Hub	43 ± 4	(32)
16	Fan Hub (60 mm Bolt Circle)	43 ± 4	(32)
24	Flame Start Aid.....	40 ± 4	(30)
19	Flywheel	137 ± 7	(101)
18	Flywheel Housing	60 ± 6	(45)
10	Flywheel Housing Cover	24 ± 3	(18)
(1/2)	Flywheel Housing Drain Plug.....	43 ± 4	(32)
—	Front Cover Cap.....	—Hand Tighten—	
15	Front Engine Support Mounting.....	112 ± 10	(82)
17	Fuel Banjo Screw (in Filter Head)	32 ± 3	(24)
Slot	Fuel Vent Screw in Banjo	8 ± 1	(6)
75-80	Fuel Filter	3/4 Turn After Contact	
19	Fuel Low Pressure Supply at Pump.....	24 ± 3	(18)

Engine Component Torque Value (Continued)

Socket Or Wrench Size MM (Inch)		Torque ± Nom	(Ft-lb)
10	Fuel Low Pressure Return at Filter Head.....	8 ± 1	(6)
24	Fuel Filter Adapter Nut.....	32 ± 3	(24)
17	Fuel Line Fitting (High Pressure).....	25 ± 3	(18)
22	Fuel Pump Drive Gear (A).....	93 ± 7	(68)
27	Fuel Pump Drive Gear (MW).....	105 ± 10	(77)
24	Fuel Pump Lock.....	15 ± 3	(11)
15	Fuel Pump Mounting Nut.....	43 ± 4	(32)
15	Fuel Solenoid Bracket.....	43 ± 4	(32)
10	Fuel Solenoid Mounting.....	10 ± 2	(7)
10	Gear Cover.....	24 ± 3	(18)
10	Gear Housing-to-Block.....	24 ± 3	(18)
(7/16)	Gear Housing Pipe Plugs.....	5 ± 1	(4)
18	Cylinder Head Mounting..... Step 1	40	(27)
 Step 2	150	(110)
 Step 3	220	(162)
10	Injector Fuel Drain Manifold.....	8 ± 1	(6)
10	Injector Retaining Capscrew.....	24 ± 3	(18)
10	Intake Manifold Cover.....	24 ± 3	(18)

Engine Component Torque Value (Continued)

Socket Or Wrench Size MM (Inch)		Torque ± Nom	(Ft-lb)
10	Lift Pump Mounting/Cover Plate.....	24 ± 3	(18)
18	Lifting Bracket.....	77 ± 6	(57)
23	Main Bearing Cap..... Step 1	60	(44)
 Step 2	119	(88)
 Step 3	176	(129)
118-131	Oil Filter.....	3/4 Turn After Contact	
10	Oil Cooler Cover.....	24 ± 3	(18)
17	Oil Pan Drain Plug.....	80 ± 4	(60)
17	Oil Pan Heater Plug.....	80 ± 4	(60)
10	Oil Pan Mounting.....	24 ± 3	(18)
22	Oil Pressure Regulator Valve.....	80 ± 4	(60)
10	Oil Pump Mounting.....	24 ± 3	(18)
10	Oil Suction Tube (Flange).....	9 ± 1	(7)
10	Oil Suction Tube Brace.....	9 ± 1	(7)
15	PTO Adapter.....	77 ± 7	(57)
13	PTO Adapter Cover Plate A Drive.....	43 ± 4	(32)
15	PTO Adapter Cover Plate B Drive.....	77 ± 7	(57)
(3/4)	PTO Gear Nut A Drive.....	100 ± 10	(74)

Engine Component Torque Value (Continued)

Socket Or Wrench Size MM (Inch)		Torque \pm Nom	(Ft-lb)
(15/16)	PTO Gear Nut B Drive.....	134 \pm 13	(100)
(11/16)	PTO Flange Companion.....	85 \pm 8	(63)
10	Rocker Support.....	43 \pm 3	(32)
14	Rocker Lever Nut.....	24 \pm 3	(18)
15	Starter Mounting (12 Point).....	77 \pm 4	(57)
10	Tach Drive Retainer.....	3 \pm .5	(2)
10	Thermostat Housing.....	24 \pm 3	(18)
T-25 Torx	Timing Pin Flange Mounting.....	5 \pm 1	(4)
13	Turbine Housing.....	11 \pm 2	(8)
7/16	Turbo Compressor Housing Clamp.....	8 \pm 1	(6)
15	Turbo Mounting Nut.....	32 \pm 3	(24)
10	Turbo Drain Tube.....	24 \pm 3	(18)
16	Turbo Oil Supply (Both Ends).....	15 \pm 2	(11)
8	Water Hose.....	5 \pm 1	(4)
(3/8)	Water Inlet Plugs.....	34 \pm 3	(25)
10	Water Pump Mounting.....	24 \pm 3	(18)
15	Valve Cover.....	24 \pm 3	(18)
-	Valve Cover Oil Fill.....		Hand Tighten
13	WABCO Air Compressor Gear.....	24 \pm 3	(18)
27	WABCO Gear Hub Mounting Nut.....	180 \pm 18	(133)

C Series Sealants

Use the sealants listed below or sealants containing equivalent properties.

Description	Sealing Method
1. Pipe Plugs	Precoated teflon or pipe sealer.
2. Gaskets	
a. Oil Pan	K&W Copper Coat [®] - Both Sides Apply Permatex [®] No. 2 to the four "T" joints and smear into the joints with finger until full.
b. Gear Cover	K&W Copper Coat [®] - Both Sides.
c. All Other Gaskets	No sealant required.
3. Cup Plugs	Loctite [®] 277 or Cummins Sealant 3375068.
4. O-rings	No sealant required.
5. Rear Camshaft Expansion Plug	Loctite [®] 277 or Cummins Sealant 3375068.
6. Fuel Pump Studs	Loctite [®] 609.
7. Turbocharger Drain (in block)	Loctite [®] 277 or Cummins Sealant 3375068.
8. Dipstick Tube (in block)	Loctite [®] 277 or Cummins Sealant 3375068.
9. Wet Flywheel Housing to Block	K&W Copper Coat [®] .
10. Front Seal (in gear cover)	Loctite [®] 277 or Cummins Sealant 3375068.
11. Rear Seal (in rear cover)	No sealant.
12. Timing Pin Housing Capscrews	Loctite [®] 59,241 liquid teflon.
13. Side Oil Fill	Loctite [®] 277 or Cummins Sealant 3375068.

C Series Lubricants

Use the lubricants listed below or lubricants containing equivalent properties.

Parts	Lubricant Required
Rod Bearings	Lubriplate 105
Main Bearings	Lubriplate 105
Cam Lobes and Journals	Lubriplate 105
Tappets	Lubriplate 105
Pistons	15W40 Engine Oil
Piston Rings	15W40 Engine Oil
Piston Pin	15W40 Engine Oil
Rocker Assemblies	15W40 Engine Oil
Push Tubes	15W40 Engine Oil + Lubriplate 105 in cup
Liner O-Ring	15W40 Engine Oil

C Series Lubricants (Continued)

Capscrews - under head and on Threads, as follows:

- Main Bearing Capscrews 15W40 Engine Oil
- Cylinder Head Capscrews 15W40 Engine Oil
- Connecting Rod Capscrews 15W40 Engine Oil
- Flywheel Mounting Capscrews 15W40 Engine Oil
- Damper Mounting Capscrews 15W40 Engine Oil
- All Other Capscrews Preservative Oil or 15W40 Engine Oil

Valve Stems	90W or 140W Oil
Front and Rear Seals to Crankshaft	Dry (use no lubricants)
Rear Seal (in seal housing)	Soapy water to install seal in housing
Lube Oil Pressure Regulator	15W40 Engine

Engine Specifications

General

Metric [U.S.]

Engine Rating and Speed	(Industrial) 150 HP at 2200 RPM
Naturally Aspirated	(Automotive) 210 HP at 2200 RPM
Turbocharged	(Industrial) 210 HP at 2200 RPM
Aftercooled	(Automotive) 235 HP at 2200 RPM
	(Industrial) 234 HP at 2200 RPM
Bore & Stroke	114mm [4.49 in.] X 135mm [5.32 in.]
Displacement	8.27 litres [504.5 cu.in.]
Compression Ratio	16.4:1
6C8.3	17.3:1
6CT8.3	16.5:1
6CTA8.3	1-5-3-6-2-4
Firing Order	
Engine Weight (With Standard Accessories)	510-606 kg [1256-1335 lb.]
Dry Weight	599-636 kg [1320-1402 lb.]
Wet Weight (With Engine Fluids)	
Lubrication	
Oil Pressure - Low Idle (Minimum Allowable)	69 kPa [10 psi]
- At Rated Speed (Minimum Allowable)	207 kPa [30 psi]
Oil Capacity of Pan	18.9-15.3 litres [20-16 U.S. Qts.]
High-Low	
Total System Capacity	22.0 litres [23.5 U.S. Qts.]
6C8.3	22.4 litres [23.7 U.S. Qts.]
6CT8.3 and 6CTA8.3	

Specifications and Torque Values C Series

Engine Specifications
Page 5-11

Cooling

Metric [U.S.]

Coolant Capacity (Engine Only)	
6C8.3 - 6CT8.3	11.4 litres [12.0 U.S. Qts.]
6CTA8.3	12.3 litres [13.0 U.S. Qts.]
Thermostat	
Starts to Open	83° C [181° F]
Fully Open	95° C [203° F]
Maximum Allowable Top Tank Temperature	100° C [212° F]
Minimum Recommended Top Tank Temperature	70 ° C [158° F]
Minimum Allowable Pressure Cap	50 kPa [7.0 psi]

Fuel

Note: For performance and fuel rate values, consult the engine data sheet or the fuel pump code for the particular model involved.

Maximum Allowable Restriction to Pump	
With Dirty Filter	95 mm Hg [3.75 in. Hg]
Maximum Allowable Return Restriction	518 mm Hg [20.4 in. Hg]

Intake

Maximum Allowable Intake Restriction with Dirty Air Filter element	
6CT8.3 - 6CTA8.3	635mm H ₂ O [25.0 in. H ₂ O]
6C8.3	508 mm H ₂ O [20.0 in. H ₂ O]
Maximum Allowable Exhaust Back Pressure Imposed by Piping & Silencer	
	75mm Hg [3.0 in. Hg]
	1000mm H ₂ O [40.0 in. H ₂ O]

Minimum Recommended Battery Capacity

Battery Size	Ambient Temperatures			
	-18° C (0° F)		0° C (32° F)	
	Cold Cranking Amperes	Reserve Capacity *	Cold Cranking Amperes	Reserve Capacity *
12 Volt	1800	640	1280	480
24 Volt**	900	320	640	240

* The number of plates within a given battery size determine reserve capacity. Reserve capacity determines the length of time sustained cranking can occur.

** Per Battery (two 12 volt batteries in series) CCA ratings are based on -18° C [0° F].

Air Starters

The air starter system (tanks, line sizes, and valves) is designed and installed by the original equipment manufacturers and the starter suppliers. Refer any questions about the air starting systems to the manufacturer.

Air Starter Maintenance

- Do not operate air starters with air pressure lower than 483 kPa [70 psi].
- Maintain the air compressor according to the recommendations outlined in the manual.
- For maximum efficiency, the hoses, tubes, and lines must not leak.
- Refer to the original equipment manufacturers' and starter manufacturers' manuals for specific information regarding the starters, valves, and systems.

Torque Specification

The C series engine uses parts that are of metric dimensions.

Always use caution to be sure that capscrews from the engine are put back in their proper locations.

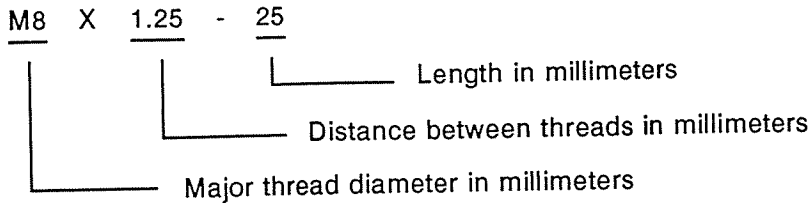

When replacing capscrews, always use a capscrew of the same measurement and strength as the capscrew being replaced. Incorrect capscrews can result in engine damage.

Metric Capscrew Nomenclature



Capscrew Markings and Torque Values (Continued)

Metric capscrews are identified by the grade number stamped on the head of the capscrew or on the surface of metric nuts. The higher the number, the greater the strength of the capscrew.

Commercial Steel Class			
Thread Diameter mm	Torque Nom [ft-lb]	Torque Nom [ft-lb]	Torque Nom [ft-lb]
5	6 [5]	8 [6]	8 [6]
6	9 [7]	14 [10]	15 [11]
8	24 [18]	34 [25]	38 [28]
10	43 [32]	64 [47]	77 [57]
12	77 [57]	112 [83]	137 [101]
14	127 [94]	180 [133]	216 [159]
16	195 [144]	266 [196]	319 [235]

Notes:

- Do not use these values when the torque values are specified in another section of the manual.
- These values are based on clean, dry threads. Reduce the value by 10% when a lubricant is used. Reduce the value by 20% if new plated capscrews are used.

Lubricant, Fuel and Coolant Specifications

Engine Lubricating Oil

The use of quality engine lubricating oils combined with appropriate oil drain and filter change intervals is a critical factor in maintaining engine performance and durability.

Cummins Engine Company, Inc. recommends the use of a high quality SAE 15W-40 heavy duty engine oil (such as Cummins Premium Blue) which meets the American Petroleum Institute (API) performance classification CE.

NOTE: CC/CD or CD/SF engine oils can be used in areas where CE oil is not yet available.

A sulfated ash limit of 1.0 mass percent is suggested for optimum valve and piston deposit and oil consumption control. The sulfated ash **must not** exceed 1.85 mass percent.

For further details and discussion of engine lubricating oils for Cummins engines, refer to Bulletin No. 3810340, Cummins Engine Oil Recommendations.

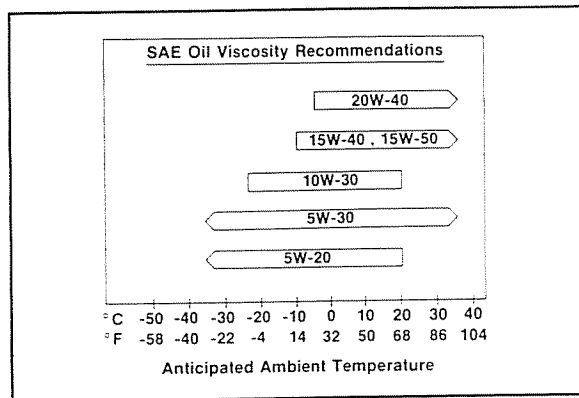

Caution: Limited use of low viscosity oils, such as 10W-30 may be used to aid in starting the engine and providing sufficient oil flow at ambient temperatures below -5°C [23°F]. However, continuous use of low viscosity oils can decrease engine life due to wear. Refer to the accompanying chart.

Artic Operation

If an engine is operated in ambient temperatures consistently below -23°C [-10°F] and there are no provisions to keep the engine warm when it is not in operation, use a synthetic CC/CD engine oil with adequate low temperature properties such as; 5W-20 or 5W-30.

The oil supplier must be responsible for meeting the performance service specifications.

△ Caution: The use of a synthetic base oil does not justify extended oil change intervals. Extended oil change intervals can decrease engine life due to factors such as; corrosion, deposits and wear.

Special "break in" engine lubricating oils are not recommended for new or rebuilt Cummins engines. Use the same type oil during the "break in" as that which is used in normal operation.

△ Caution: A sulfated ash limit of 1.85% has been placed on all engine lubricating oils recommended for use in Cummins engines. Higher ash oils may cause valve and/or piston damage and lead to excessive oil consumption.

For natural gas engines a sulfated ash range of .03 to .85 mass percent is recommended. Cummins Engine Company, Inc., does not recommend the use of ashless oils for natural gas engines.

Additional information regarding lubricating oil availability throughout the world is available in the "E.M.A. Lubricating Oils Data Book for Heavy Duty Automotive and Industrial Engines." The data book may be ordered from the engine Manufacturers Association, One Illinois Center, 111 East Wacker Drive, Chicago, IL U.S.A. 60601. The telephone number is: (312) 644-6610.

Fuel



Warning: Do not mix gasoline or alcohol with diesel fuel. This mixture can cause an explosion.

Cummins recommends the use of ASTM No. 2 D fuel. The use of No. 2 diesel fuel will result in optimum engine performance. At operating temperatures below 0° C [32° F], acceptable performance can be obtained by using blends of No. 2 D and No. 1 D. The use of lighter fuels can reduce fuel economy.

The fuel's viscosity must be kept above 1.3 cSt to provide adequate fuel system lubrication.

Coolant

Heavy-duty diesel engines require a balanced coolant mixture of water, antifreeze, and supplemental coolant additive (DCA4). Supplemental coolant additive recommendations are included in this Section.) Drain and replace the mixture every 2 years.

DCA4 is recommended to inhibit corrosion in the cooling system.

Antifreeze concentration level in coolant should not exceed required protection levels.

- A 50/50 antifreeze/water mix provides protection to -34° F. This is more than adequate for most geographic locations.
- Never exceed a 70/30 antifreeze/water mix ratio.
- Never use 100 percent antifreeze for makeup coolant.

DCA4 Unit Maintenance Guide

Use the supplemental coolant additive to protect the engine cooling system from corrosion. Antifreeze alone does not provide enough corrosion protection for a heavy-duty diesel engine. Supplemental corrosion protection must be supplied through periodic additions of the coolant additive to the coolant.

DCA4 can be used for in service engines provided the cooling systems are drained and flushed, and the old coolant is disposed of prior to installation of new coolant and the appropriate DCA4 filter.

Mixing of DCA4 and other supplemental coolant additives is **not** recommended because there is currently no test kit available to measure concentration levels with mixed chemical solutions.

With the use of DCA4 or the continued use of other supplemental coolant additives, Cummins Engine Company recommends the following steps to prevent overconcentration and gel formation:

- Antifreeze concentration level in coolant must **not** exceed the required protection levels.
- Maintain proper supplemental coolant additive levels (do not overconcentrate).
- With the use of any supplemental coolant additive, we recommend an antifreeze containing less than 0.1 percent of silicate (measured as anhydrous alkali metasilicate).

To protect against corrosion, a new coolant charge must be brought up to one DCA4 unit per 3.8 litres [1.00 U.S. gallon] of coolant (initial charge).

Each time the coolant is drained and replaced, the coolant must be recharged with DCA (or equivalent). New coolant can be correctly charged with supplemental coolant additives by using liquid DCA4 concentrates or DCA4 filters listed in the following table.

If coolant is added between drain intervals, additional DCA4 will be required. See **Maintenance Guidelines** (Section 2) or **Engine Specifications** (Section 5) for the correct test kit to check DCA concentration. Check the coolant periodically. The DCA4 concentration must not fall below 1.0 unit per 3.8 litres [1.00 U.S. gallon] or exceed 2 units per 3.8 litres [1.00 U.S. gallon].

DCA4 Unit Maintenance Guide

Fleetguard® Part No.	Cummins Part No.	DCA4 Units
DCA4 Liquid		
DCA 60L	3315459	4*
DCA4 Filter		
WF-2070	3318157	2
WF-2071	3315116	4
WF-2072	3318201	6
WF-2073	3315115	8
WF-2077	None	0

*If DCA60L is used, do not use a filter that contains coolant additives. The combination of liquid and filter coolant additives will result in overconcentration.

DCA4 Maintenance Guide

Maintenance Intervals		
Total Cooling System Capacity Litres [U.S. Gallons] (A)	Initial Charge (B)	6 Months
		500 Hours
		16,000 KM (10,000 MI)
30 to 57 [8 - 15]	WF-2072	WF-2070

Notes:

- A. Consult the vehicle equipment manufacturer's maintenance information for total cooling system capacity.
- B. After draining and replacing the coolant, install the initial per charge coolant filter to provide the recommended level of DCA4 concentration.
- C. Change coolant filters at regular intervals to protect the cooling system.
- D. Check the coolant additive concentration regularly. Check cooling systems using DCA4 only with DCA4 Coolant Test Kit, Fleetguard® Part No. CC-2600.

Section 6 - Service Assistance

Table of Contents

Subject	Page
Routine Service Assistance	6-2
Emergency Service Assistance	6-2
Problem Solving Assistance.....	6-3
Directories:	
- Division and Regional Offices	6-4
- Distributors and Branches:	
.. United States.....	6-5
.. Canada	6-19
.. Australia	6-22
.. New Zealand	6-23
.. Puerto Rico.....	6-24

Service Assistance

Routine Service Assistance

Personnel at a Cummins Authorized Repair Location can assist you with the correct operation or service of your engine. We have a worldwide service network of more than 5,000 Cummins Distributors and Dealers who have been trained to provide sound advice, expert service, and complete parts support. Check the telephone directory yellow pages or refer to the directory in this section for the nearest Cummins Authorized Repair Location.

Emergency Service Assistance

The Cummins Customer Relations Department provides a 24-hour, toll free telephone number to aid in locating emergency service when a local Cummins Authorized Repair Location can not be reached. The emergency service telephone numbers are:

- United States and Canada (excluding Alaska and Hawaii)
 - (800) D-I-E-S-E-L-S
 - (800) 343-7357
- Outside of North America contact your Regional Office. Telephone numbers and addresses are listed in this section.

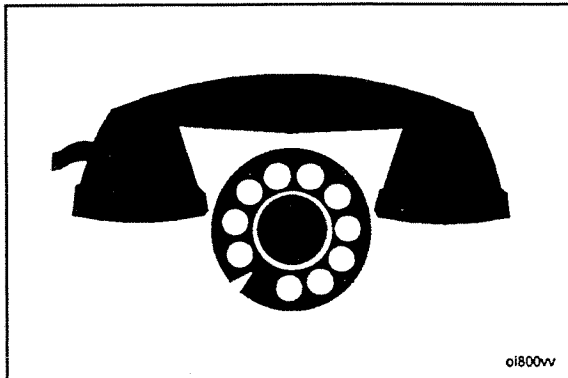

Problem Solving Assistance:

Normally, any problem that arises with the sale, service, or repair of your engine can be handled by a Cummins Authorized Repair Location in your area. Refer to the telephone directory yellow pages for the one nearest you. If the problem has **not** been handled satisfactorily, follow the steps outlined below:

1. If the disagreement is with a Dealer, talk to the Cummins Distributor with whom he has his service agreement.
2. If the disagreement is with a Distributor, call the nearest Cummins Division or Regional Office; however, most problems are solved below the Division or Regional office level. Telephone numbers and addresses are listed in this section. Before calling, write down the following information:
 - a. Engine model and serial number
 - b. Type and make of equipment
 - c. Total kilometers [miles] or hours of operation
 - d. Warranty start date
 - e. Nature of problem
 - f. Summary of the current problem arranged in the order of occurrence
 - g. Name and location of the Cummins Distributor or Dealer
3. If a problem can **not** be resolved satisfactorily through your Cummins Authorized Repair Location or Division Office, write to:

Customer Relations - 60406, Cummins Engine Company, Inc., Box 3005, Columbus, IN 47202-3005

Directory - Division and Regional Offices

NOTE: The following list contains offices in U.S., Canada, Australia, New Zealand and Puerto Rico.

United States

Eastern Division Office
Cummins Engine Company, Inc.
1100 - 31st Street, Suite 275
Downers Grove, IL 60515
Telephone: (312) 852-6604

Eastern Regional Office
Cummins Engine Company, Inc.
10 Wright Street
Suite 401
Westport, CT 06880
Telephone: (203) 226-7951

Southern Regional Office
Cummins Engine Company, Inc.
425 Franklin Road S.E.
Suite 500
Marietta, GA 30067
Telephone: (404) 423-1108

Plains Regional Office
Cummins Engine Company, Inc.
Twin Towers, North
Suite 633
8585 North Stemmons Freeway
Dallas, TX 75247
Telephone: (214) 638-5410

Western Division Office
Cummins Engine Company, Inc.
Plaza North Building, Suite 406
5660 South Syracuse Circle
Englewood, CO 80111
Telephone: (303) 773-2866

Western Regional Office
Cummins Engine Company, Inc.
375 No. Wiget Lane
Suite 220
Walnut Creek, CA 94598
Telephone: (415) 943-6901

Canada

Canadian Division Office
Cummins Diesel of Canada, Ltd.
700 Dorval Drive
Suite 600
Oakville, Ontario L6K 3V3
Telephone: (416) 842-8070

Western Canada Regional Office
Cummins Diesel of Canada, Ltd.
Suite 306
3701 East Hastings St.
Burnaby, B.C., V5C 2H6
Telephone: (604) 299-9361

Australia Regional Office

Cummins Diesel Australia
513-515 Maroondah Highway
Ringwood 3134
Victoria, Australia
Telephone: (3) 871-2222

NOTE: This office also serves New Zealand.

Cummins Americas Regional Office

Cummins Caribbean
16085 N. W. 52nd Avenue
Hialeah, FL 33014
Telephone: (305) 621-1300

NOTE: This office serves Puerto Rico.

Distributors and Branches, United States

Alabama

Birmingham Distributor

Cummins Alabama, Inc.
2200 Pinson Highway
P.O. Box 1147
Birmingham, AL 35201
Telephone: (205) 841-0421

Decatur Branch

Cummins Alabama, Inc.
Ratliff Industrial Park
Refreshment Place
P.O. Box 1825
Decatur, AL 35602
Telephone: (205) 350-5600

Mobile Branch

Cummins Alabama, Inc.
1924 Beltline Highway,
I-65 North
P.O. Box 2566
Mobile, AL 36601
Telephone: (205) 456-2236

Mobile Marine Branch

Cummins Alabama, Inc.
Marine Center
921 Corporate Drive South
P.O. Box 2566
Mobile, AL 36601
Telephone: (205) 456-2236

Montgomery Branch

Cummins Alabama, Inc.
2325 West Fairview Avenue
P.O. Box 9271
Montgomery, AL 36108
Telephone: (205) 263-2594

Alaska

Anchorage - (Branch of Portland)

Cummins Northwest, Inc.
2618 Commercial Drive
Anchorage, AK 99501
Telephone: (907) 279-7594

Bristol Bay Borough - (Branch of Portland)

Cummins Northwest, Inc.
Naknek Marine Center
Naknek, Alaska
Telephone: (907) 246-3350

Arizona

Phoenix Distributor and Branch

Cummins Southwest, Inc.
2239 North Black Canyon Hwy.
P.O. Box 6697
Phoenix, AZ 85005
Telephone: (602) 252-8021

Tucson Branch

Cummins Southwest, Inc.
1912 West Prince Road
Tucson, AZ 85705
Telephone: (602) 887-7440

Arkansas

Little Rock - (Branch of Memphis)

Cummins Mid-South, Inc.
6700 Interstate 30
P.O. Box 9000
Little Rock, AR 72219
Telephone: (501) 568-2200
Parts: (501) 568-2213

Van Buren - (Branch of Memphis)

Cummins Mid-South, Inc.
1906 N. 6th Street
Van Buren, AR 72956
Telephone: Sales: (501) 474-7953
Parts: (501) 474-7951
Service: (501) 474-7955

California

San Francisco Distributor and Branch

Cummins West, Inc.
1960 Folsom Street
San Francisco, CA 94103
Telephone: (415) 621-8930

Bakersfield Branch

Cummins West, Inc.
301 East Fourth Street
Bakersfield, CA 93307
Telephone: (805) 325-9404

Eureka Branch

Cummins West, Inc.
1048 Vigo Street
Eureka, CA 95501
Telephone: (707) 443-7385

Fresno Branch

Cummins West, Inc.
2740 Church Avenue
Fresno, CA 93706
Telephone: (209) 486-6050

Los Angeles Industrial Branch

Cummins West, Inc.
Industrial Division
1636 Staunton Avenue
Los Angeles, CA 90021
Telephone: (213) 746-3858/9

Los Angeles Operations

Cummins West, Inc.
1661 McGarry Street
Los Angeles, CA 90021
Telephone: (213) 746-3850
Branch: (213) 746-6410

Montebello Branch

Cummins West, Inc.
1105 South Greenwood Avenue
Montebello, CA 90640
Telephone: (213) 728-8111

Redding Branch

Cummins West, Inc.
2725 Favretto Avenue
Redding, CA 96001
Telephone: (916) 241-2154

Rialto Branch

Cummins West, Inc.
161 East Valley Blvd.
Rialto, CA 92376
Telephone: (714) 877-0433

San Diego Branch

Cummins West, Inc.
9191 Kearny Villa Court
San Diego, CA 92123
Telephone: (619) 278-4160

Stockton Office

Cummins West, Inc.
41 W. Yokuts Avenue, Suite 131
Stockton, CA 95207
Telephone: (209) 473-0386

West Sacramento Branch

Cummins West, Inc.
2661 Evergreen Avenue
West Sacramento, CA 95691
Telephone: (916) 371-0630

Colorado

Denver Distributor

Cummins Power, Inc.
5100 East 58th Avenue
Commerce City, CO 80022
Telephone: (303) 287-0201

Craig Branch

Cummins Power, Inc.
939 East First St.
P.O. Box 1083 (Zip 81626)
Craig, CO 81625
Telephone: (303) 824-8231

Gen Power

3801 E. 50th Avenue
Denver, CO 80216
Telephone: (303) 399-7697

Grand Junction Branch

Cummins Power, Inc.
2380 U.S. Highway 6 & 50
P.O. Box 339
Grand Junction, CO 81501
Telephone: (303) 242-5776

Connecticut

Hartford Distributor

Cummins Diesel Engines of
Connecticut, Inc.
260 Murphy Road
Hartford, CT 06114
Telephone: (203) 527-9156
Parts: (203) 525-5606

Florida

Tampa Distributor and Branch

Cummins Southeastern
Power, Inc.
5910 East Hillsborough Avenue
P.O. Box 11737
Tampa, FL 33680
Telephone: (813) 626-1101

Ft. Myers Branch

Cummins Southeastern Power, Inc.
2671 Edison Avenue
Ft. Myers, FL 33902
Telephone: (813) 337-1211

Jacksonville Branch

Cummins Southeastern
Power, Inc.
2060 West 21st Street
P.O. Box 12036
Jacksonville, FL 32209
Telephone: (904) 355-3437

Miami Branch

Cummins Southeastern
Power, Inc.
9900 N.W. 77th Court
Hialeah Gardens, FL 33016-2487
Telephone: (305) 821-4200

Orlando Branch

Cummins Southeastern
Power, Inc.
4820 North
Orange Blossom Trail
Orlando, FL 32810
Telephone: (305) 298-2080

Georgia

Atlanta Distributor

Cummins South, Inc.
100 University Avenue, S.W.
Atlanta, GA 30315
Telephone: (404) 524-7716

Albany Branch

Cummins South, Inc.
5430 Newton Road
Albany, GA 31707
Telephone: (912) 888-6210

Augusta Branch

Cummins South, Inc.
1255 New Savannah Road
Augusta, GA 30901
Telephone: (404) 722-8825

Columbus Branch

Cummins South, Inc.
1435 Jacqueline Drive
Columbus, GA 31907
Telephone: (404) 563-2536

Dalton Branch

Cummins South, Inc.
204 Carbondale Road
Dalton, GA 30720
Telephone: (404) 277-1144

Savannah Branch

Cummins South, Inc.
8 Interchange Court
Savannah, GA 31401
Telephone: (912) 232-5565

Hawaii

Honolulu Distributor

Cummins Hawaii, Inc.
(Street Address)
215 Puuhale Road
Honolulu, HI 96819

(Mailing Address)

P.O. Box 30208
Honolulu, HI 96820
Telephone: (808) 845-6606

Idaho

Boise - (Branch of Salt Lake City)

Cummins
Intermountain Idaho, Inc.
2851 Federal Way
P.O. Box 5215
Boise, ID 83705
Telephone: (208) 336-5000

Pocatello - (Branch of Salt Lake City)

Cummins Intermountain
Rt.1, Box 114,
Highway 30 West
Pocatello, ID 83201
Telephone: (208) 234-1661

Illinois

Chicago - (Branch of Indianapolis)

Cummins Mid-States Power, Inc.
5555 S. Kilpatrick Avenue
Chicago, IL 60629
Telephone: (312) 581-3100

Rock Island - (Branch of Omaha)

Cummins Great Plains
Diesel, Inc.
730 - 31st Avenue
Rock Island, IL 61201
Telephone: (309) 793-6650

Rockford - (Branch of Indianapolis)

Cummins Mid-States Power, Inc.
4117 - 11th Street
Rockford, IL 61109
Telephone: (815) 397-0600

Bloomington-Normal - (Branch of Indianapolis)

Cummins Mid-States Power, Inc.
P.O. Box 348
(at U.S. 51 N and I-55)
Bloomington-Normal, IL 61761
Telephone: (309) 452-4454

Mt. Vernon - (Branch of St. Louis)

Cummins Missouri, Inc.
819 Casey Street
P.O. Box 1744
Mt. Vernon, IL 62864
Telephone: (618) 244-1232

Indiana

Indianapolis Distributor

Cummins Mid-States Power, Inc.
2421 Production Drive
P.O. Box 41317
Indianapolis, IN 46241-0317
Telephone: (317) 243-7979

Evansville - (Branch of Louisville)

Cummins Cumberland, Inc.
1650 North Fares Avenue
Evansville, IN 47711
Telephone: (812) 425-2464

Ft. Wayne Branch

Cummins Mid-States Power, Inc.
3415 Coliseum Blvd. West
(At Jct. I-69 & 30/33)
Ft. Wayne, IN 46808
Telephone: (219) 482-3691

Gary - (Branch of Indianapolis)

Cummins Mid-States Power, Inc.
1440 Texas Street
Gary, IN 46402
Telephone: (219) 885-5591

Iowa

Cedar Rapids - (Branch of Omaha)

Cummins Great Plains
Diesel, Inc.
215 - 50th Avenue, S.W.
P.O. Box 1107
Cedar Rapids, IA 52406
Telephone: (319) 366-7537
(24 hours)

Des Moines - (Branch of Omaha)

Cummins Great Plains
Diesel, Inc.
1680 N.E. 51st Avenue
P.O. Box B
Des Moines, IA 50313
Telephone: (515) 262-9591
Parts: (515) 262-9744
(515) 262-9591 after midnight

*John
Spitzer*

Kansas

Colby - (Branch of Kansas City, Missouri)

Cummins Mid-America, Inc.
1880 South Range
P.O. Box 465
Colby, KS 67701-0465
Telephone: (913) 462-3945
(913) 462-3143

Garden City - (Branch of Kansas City, Missouri)

Cummins Mid-America, Inc.
2203 W. Jones Frontage Road
Box 2598
Garden City, Kansas 67846
Telephone: (316) 275-2277

Wichita - (Branch of Kansas City, Missouri)

Cummins Mid-America, Inc.
5101 North Broadway
P.O. Box 734
Wichita, KS 67201-0734
Telephone: (316) 838-0875
(24 hours)

Olathe - (Branch of Kansas City, Missouri)

Cummins Mid-America, Inc.
11615 South Rogers Road
Olathe, KS 66062
Telephone: (913) 469-5660

Kentucky

Louisville Distributor

Cummins Cumberland, Inc.
(Corporate Office)
9822 Bluegrass Parkway
Louisville, KY 40299
Telephone: (502) 491-6060

Hazard Branch

Cummins Cumberland, Inc.
Highway 15 North
P.O. Box 510
Hazard, KY 41701
Telephone: (606) 436-5718

Louisville Branch

Cummins Cumberland, Inc.
9820 Bluegrass Parkway
Louisville, KY 40299
Telephone: (502) 491-4263

Paducah Branch

Cummins Cumberland, Inc.
5108 Cairo Road
Paducah, KY 42001
Telephone: (502) 442-6559

Louisiana

Morgan City - (Branch of Memphis)

Cummins Mid-South, Inc.
Hwy. 90 East
P.O. Box 2897
Morgan City, LA 70381-2897
Telephone: (504) 631-0576
(24 hours)

New Orleans - (Branch of Memphis)

Cummins Mid-South, Inc.
4628 I-10 Service Road
P.O. Box 868, Metairie, LA
New Orleans, LA 70004-0868
Telephone: (504) 885-5675
(24 hours)

Maine

South Portland - (Branch of Boston)

Cummins North Atlantic, Inc.
205 Lincoln Street
South Portland, ME 04106
Telephone: (207) 767-3356

Maryland

Baltimore - (Branch of Charlotte)

Cummins Atlantic, Inc.
3140 Washington Boulevard
Baltimore, MD 21230
Telephone: (301) 644-6500

Massachusetts

Boston Distributor

Cummins North Atlantic, Inc.
100 Allied Drive
Dedham, MA 02026
Telephone: (617) 329-1750

West Springfield Branch

Cummins North Atlantic, Inc.
124 Ashley Avenue
West Springfield, MA 01089
Telephone: (413) 737-2659

Michigan

Detroit Distributor

Cummins Michigan, Inc.
41216 Vincent Court
Novi, MI 48050
Telephone: (313) 478-9700

Dearborn Branch

Cummins Michigan, Inc.
3760 Wyoming Avenue
Dearborn, MI 48120
Telephone: (313) 843-6200

Grand Rapids Branch

Cummins Michigan, Inc.
3715 Clay Avenue, S.W.
Grand Rapids, MI 49508
Telephone: (616) 538-2250

Saginaw Branch

Cummins Michigan, Inc.
722 N. Outer Drive
Saginaw, MI 48605
Telephone: (517) 752-5200

Iron Mountain - (Branch of De Pere)

Cummins Great Lakes, Inc.
P.O. Box 703
1901 North Stephenson Avenue
Iron Mountain, MI 49801
Telephone: (906) 774-2424

Minnesota

St. Paul Distributor

Cummins Diesel Sales, Inc.
2690 Cleveland Avenue North
St. Paul, MN 55113

(Mailing Address)

P.O. Box 64578
St. Paul, MN 55164
Telephone: (612) 636-1000

Duluth Branch

Cummins Diesel Sales, Inc.
3115 Truck Center Drive
Duluth, MN 55806
Telephone: (218) 628-3641

Hibbing Branch

Cummins Diesel Sales, Inc.
604 West 41st Street
P.O. Box 159
Hibbing, MN 55746
Telephone: (218) 263-7558

Mississippi

Jackson - (Branch of Memphis)

Cummins Mid-South, Inc.
New Highway 49 South
P.O. Box 54224
Jackson, MS 39208
Telephone: (601) 939-1800

Missouri

Kansas City Distributor

Cummins Mid-America, Inc.
1760 North Universal
Kansas City, MO 64120
General Accounting Office
Telephone: (816) 483-5070

Kansas City Branch

Cummins Mid-America, Inc.
3527 Gardner Avenue
Kansas City, MO 64120
Telephone: (816) 483-6313

Joplin Branch

Cummins Mid-America, Inc.
3507 East 20th Street
Joplin, MO 64801
Telephone: (417) 623-1661

Springfield Branch

Cummins Mid-America, Inc.
3637 East Kearney
Springfield, MO 65803
Telephone: (417) 862-0777

St. Louis Distributor
Cummins Missouri, Inc.
9305 Natural Bridge Road
St. Louis, MO 63134
Telephone: (314) 429-0095

St. Louis Branch
Cummins Missouri, Inc.
7210 Hall Street,
St. Louis, MO 63147
Telephone: (314) 389-5400

Columbia Branch
Cummins Missouri, Inc.
Hwy. 63 North
P.O. Box 1726
Columbia, MO 65205
Telephone: (314) 449-3711

Sikeston Branch
Cummins Missouri, Inc.
101 Keystone Drive
P.O. Box 786
Sikeston, MO 63801
Telephone: (314) 472-0303

Montana

Billings - (Branch of Denver)
Cummins Power, Inc.
5151 Midland Road
P.O. Box 30377
Billings, MT 59101
Telephone: (406) 245-4194

Great Falls - (Branch of Denver)
Cummins Power, Inc.
415 Vaughn Road
P.O. Box 3021
Great Falls, MT 59403
Telephone: (406) 452-8561

Missoula - (Branch of Portland)
Cummins Northwest, Inc.
4950 North Reserve Street
Missoula, MT 59801
Telephone: (406) 728-1300

Nebraska

Omaha Distributor and Branch
Cummins Great Plains
Diesel, Inc.
5515 Center Street
P.O. Box 6068
Omaha, NE 68106
Telephone: (402) 551-7678
(24 hours) or
(402) 493-4656

Kearney Branch
Cummins Great Plains
Diesel, Inc.
515 Central Avenue
P.O. Box 1326
Kearney, NE 68847
Telephone: (308) 234-1994

Scottsbluff Branch
Cummins Great Plains Diesel, Inc.
P.O. Box 1498
Scottsbluff, NE 69361
Telephone: (308) 635-0402 or
(308) 234-1994

Nevada

Battle Mountain - (Branch of San Francisco)
Cummins West, Inc.
240 N. Trescott Street
Battle Mountain, NV 89820
Telephone: (702) 635-2790

Las Vegas - (Branch of San Francisco)
Cummins West, Inc.
3337 South Industrial Road
Las Vegas, NV 89102
Telephone: (702) 735-4058

Sparks - (Branch of San Francisco)
Cummins West, Inc.
150 Glendale Avenue
Sparks, NV 89431
Telephone: (702) 331-4983

New Jersey

Newark - (Branch of Bronx)
Cummins Metropower, Inc.
Routes U.S. 1 & 22
Newark, NJ 07114
Telephone: (201) 242-2255

New Mexico

Albuquerque - (Branch of Phoenix)
Cummins Southwest, Inc.
1921 Broadway N.E.
Albuquerque, NM 87102
Telephone: (505) 247-2441

Farmington - (Branch of Phoenix)
Cummins Southwest, Inc.
1101 North Troy King Road
Farmington, NM 87401
Telephone: (505) 327-7331

Hobbs - (Branch of Phoenix)
Cummins Southwest, Inc.
3600 Lovington Highway
Hobbs, NM 88240
Telephone: (505) 392-3533

New York

Bronx Distributor
Cummins Metropower, Inc.
890 Zerega Avenue
Bronx, NY 10473
Telephone: (212) 892-2400

Newburgh Branch
Cummins Metropower, Inc.
724 Route 9W
Newburgh, NY 12550
Telephone: (914) 561-2887

Plainview Branch
Cummins Metropower, Inc.
105 South Service Road
Plainview, Long Island,
NY 11803
Telephone: (516) 249-7500

Syracuse - (Branch of Boston)
Cummins North Atlantic, Inc.
29 Eastern Avenue
Syracuse, NY 13211
Telephone: (315) 437-2751

Albany - (Branch of Boston)
Cummins North Atlantic, Inc.
101 Railroad Avenue
Albany, NY 12205
Telephone: (518) 459-1710

Buffalo - (Branch of Boston)
Cummins North Atlantic, Inc.
480 Lawrence Bell Dr.
Williamsville, NY 14221-7090
Telephone: (716) 631-3211

North Carolina

Charlotte Distributor
Cummins Atlantic, Inc.
11101 Nations Ford Road
P.O. Box 240729
Charlotte, NC 28224
Telephone: (704) 588-1240

Charlotte Branch
Cummins Atlantic, Inc.
3700 North Interstate 85
P.O. Box 26603
Charlotte, NC 28221-6603
Telephone: (704) 596-7690

Greensboro Branch
Cummins Atlantic, Inc.
513 Preddy Boulevard
P.O. Box 22066
Greensboro, NC 27420
Telephone: (919) 275-4531

Wilson Branch
Cummins Atlantic, Inc.
(Street Address)
1514 Cargill Avenue
Wilson, NC 27893

(Mailing Address)
P.O. Box 1177
Wilson, NC 27894
Telephone: (919) 237-9111

North Dakota

Dickinson - (Branch of St. Paul)
Cummins Diesel Sales, Inc.
Highway 10 West
P.O. Box 145
Dickinson, ND 58601
Telephone: (701) 225-9194
(701) 677-5354
after 12:30 a.m.

Fargo - (Branch of St. Paul)

Cummins Diesel Sales, Inc.
4050 West Main Avenue
P.O. Box 2111
Fargo, ND 58102
Telephone: (701) 282-2466

Grand Forks - (Branch of St. Paul)

Cummins Diesel Sales, Inc.
4728 Gateway Drive
P.O. Box 636
Grand Forks, ND 58201
Telephone: (701) 775-8197
(701) 772-7689
after 12:30 a.m.

Minot - (Branch of St. Paul)

Cummins Diesel Sales, Inc.
Highway 2 & 52 Bypass
P.O. Box 1179
Minot, ND 58701
Telephone: (701) 852-3585
(701) 839-3417
after 12:30 a.m.

Williston - (Branch of St. Paul)

Cummins Diesel Sales, Inc.
Highway 2 North
P.O. Box 1106
Williston, ND 58801
Telephone: (701) 774-8843

Ohio

Columbus Distributor and Branch

Cummins Ohio, Inc.
4000 Lyman Drive
Box 10
Hilliard (Columbus), OH 43026
Telephone: (614) 771-1000

Akron Branch

Cummins Ohio, Inc.
1033 Kelly Avenue
Akron, OH 44306
Telephone: (216) 773-7821

Cincinnati Branch

Cummins Ohio, Inc.
10470 Evendale Drive
Cincinnati, OH 45241
Telephone: (513) 563-6670

Cleveland Branch

Cummins Ohio, Inc.
7585 Northfield Road
Cleveland, OH 44146
Telephone: (216) 439-6800

Lima Branch

Cummins Ohio, Inc.
960 Broadway
Lima, OH 45804
Telephone: (419) 227-2641

Strasburg Branch

Cummins Ohio, Inc.
777 South Wooster Avenue
Box 136
Strasburg, OH 44680
Telephone: (216) 878-5511
After hours: (216) 364-1433

Toledo Branch

Cummins Ohio, Inc.
801 Illinois Avenue
Maumee
Toledo, OH 43537
Telephone: (419) 893-8711

Youngstown Branch

Cummins Ohio, Inc.
7145 Masury Road
Hubbard
Youngstown, OH 44425
Telephone: (216) 534-1935

Oklahoma

Duncan - (Branch of Arlington)

Cummins Southern Plains, Inc.
1400 East Bois D'Arc
P.O. Box 310
Duncan, OK 73534-0310
Telephone: (405) 255-1414
(24 Hours)

Oklahoma City - (Branch of Arlington)

Cummins Southern Plains, Inc.
5800 West Reno
P.O. Box 1636
Oklahoma City, OK 73101-1636
Telephone: (405) 946-4481
(24 hours)

Tulsa - (Branch of Arlington)

Cummins Southern Plains, Inc.
161st E. Avenue & I-44
P.O. Box 1616
Tulsa, OK 74147-1616
Telephone: (918) 234-3200
(24 hours)

Oregon

Portland Distributor and Branch

Cummins Northwest, Inc.
4711 N. Basin Avenue
P.O. Box 2710 (97208-2710)
Portland, OR 97217
Telephone: (503) 289-0900
Toll-Free Oregon
WATS Line: (800) 452-1070

Bend Branch

Cummins Northwest, Inc.
3500 N. Highway 97
P.O. Box 309
Bend, OR 97709
Telephone: (503) 389-1900

Eugene Branch

Cummins Northwest, Inc.
91201 Industrial Parkway
Coburg, OR 97401

(Mailing Address)

P.O. Box 10877
Eugene, OR 97440
Telephone: (503) 687-0000

Medford Branch

Cummins Northwest, Inc.
4045 Crater Lake Highway
Medford, OR 97501
Telephone: (503) 779-0151

North Bend Branch

Cummins Northwest, Inc.
612 California Avenue
P.O. Box 447
North Bend, OR 97459
Telephone: (503) 756-3111

Pendleton Branch

Cummins Northwest, Inc.
223 S.W. 23rd Street
Pendleton, OR 97801
Telephone: (503) 276-2561

Pennsylvania

Philadelphia Distributor

Cummins Diesel Engines, Inc.
3941 Commerce Avenue
Willow Grove, PA 19090-1108
Telephone: (215) 657-2200

Philadelphia Branch

Cummins Diesel Engines, Inc.
2727 Ford Road
Keystone Industrial park
Bristol, PA 19007
Telephone: (215) 785-6005

Ashland Branch

Cummins Diesel Engines, Inc.
32 Lehigh Street
Ashland, PA 17921
Telephone: (717) 875-2200

Clearfield Branch

Cummins Diesel Engines, Inc.
Clearfield Parts Center
501 Williams Street
Clearfield, PA 16830
Telephone: (814) 765-2421

Harrisburg Branch

Cummins Diesel Engines, Inc.
Lewis Road and Penhar Drive
P.O. Box 4215
Harrisburg, PA 17111
Telephone: (717) 564-1344

Mercer Branch

Cummins Diesel Engines, Inc.
R.D.#5, Box 58
Mercer, PA 16127
Telephone: (412) 748-4586

Monroeville Branch

Cummins Diesel Engines, Inc.
2740 Mossie Boulevard
Monroeville, PA 15146
Telephone: (412) 856-6700

South Carolina

Charleston - (Branch of Charlotte)

Cummins Atlantic, Inc.
3010 West Montague Avenue
P.O. Box 10341
Charleston, SC 29411
Telephone: (803) 554-5112

Columbia - (Branch of Charlotte)

Cummins Atlantic, Inc.
1233 Bluff Road
P.O. Box 13543
Columbia, SC 29201
Telephone: (803) 799-2410

South Dakota

Rapid City - (Branch of Omaha)

Cummins Great Plains
Diesel, Inc.
2310 Haines Avenue
P.O. Box 244
Rapid City, SD 57701
Telephone: (605) 343-6130

Sioux Falls - (Branch of Omaha)

Cummins Great Plains
Diesel, Inc.
701 East 54th Street North
Sioux Falls, SD 57104
Telephone: (605) 336-1715
(605) 334-6492
after 5:30 p.m.

Tennessee

Memphis Distributor & Parts Distribution Center

Cummins Mid-South, Inc.
666 Riverside Drive
P.O. Box 3080
Memphis, TN 38103
Telephone: (901) 577-0666

Memphis Branch

Cummins Mid-South, Inc.
1784 E. Brooks Road
Memphis, TN 38116
Telephone:
Sales Admin.-(901) 345-7424
Parts - - - -(901) 345-1784
Service - - - -(901) 345-6185

Nashville - (Branch of Louisville)

Cummins Cumberland, Inc.
706 Spence Lane
Nashville, TN 37217
Telephone: (615) 366-4341

Knoxville - (Branch of Louisville)

Cummins Cumberland, Inc.
1211 Ault Road
Knoxville, TN 37914
Telephone: (615) 523-0446

Chattanooga - (Branch of Atlanta)

Cummins South, Inc.
1509 East 26th Street
Chattanooga, TN 37407
Telephone: (615) 629-1447

Texas

Arlington Distributor and Branch

Cummins Southern Plains, Inc.
P.O. Box 90027
Arlington, TX 76004-3027
Telephone: (817) 640-6801
(24 hours)

Amarillo Branch

Cummins Southern Plains, Inc.
5224 Interstate 40 -
Expressway East
P.O. Box 31570
Amarillo, TX 79120-1570
Telephone: (806) 373-3793
(24 hours)

Brownsville Branch

Cummins Southern Plains, Inc.
Shrimp Basin
Star Route Box 19
Brownsville, TX 78521

Corpus Christi Branch

Cummins Southern Plains, Inc.
1302 Corn Products Road
P.O. Box 48
Corpus Christi, TX 78403-0048
Telephone: (512) 289-0700
(24 hours)

Dallas Branch

Cummins Southern Plains, Inc.
3707 Irving Boulevard
Dallas, TX 75247
Telephone: (214) 631-6400
(24 hours)

Fort Worth Branch

Cummins Southern Plains, Inc.
3250 North Freeway
Fort Worth, TX 76111
Telephone: (817) 624-2107
(24 hours)

Houston Branch

Cummins Southern Plains, Inc.
4750 Homestead Road
P.O. Box 1367
Houston, TX 77251-1367
Telephone: (713) 675-7421
(24 hours)

Lubbock Branch

Cummins Southern Plains, Inc.
120 Southeast Loop 289
P.O. Box 3927
Lubbock, TX 79452-3927
Telephone: (806) 745-4605
(24 hours)

Mesquite (East Dallas) Branch

Cummins Southern Plains, Inc.
2615 Big Town Blvd.
Mesquite, TX 75150
Telephone: (214) 321-5555
(24 hours)

Odessa Branch

Cummins Southern Plains, Inc.
1210 South Grandview
P.O. Box 633
Odessa, TX 79760-0633
Telephone: (915) 332-9121
(24 hours)

Orange Branch

Cummins Southern Plains, Inc.
3514 Interstate 10, West
P.O. Box 2709
Orange, TX 77631-2709
Telephone: (Orange)
(409) 883-6362
(24 hours)

San Antonio Branch

Cummins Southern Plains, Inc.
6226 Pan Am Expressway North
P.O. Box 18385
San Antonio, TX 78218-0385
Telephone: (512) 655-5420
(24 hours)

El Paso - (Branch of Phoenix)

Cummins Southwest, Inc.
14333 Gateway West
El Paso, TX 79927
Telephone: (915) 852-4200

Utah

Salt Lake City Distributor

Cummins Intermountain
Diesel Sales Co.
1030 South 300 West
P.O. Box 25428
Salt Lake City, UT 84125
Telephone: (801) 355-6500

Vernal Branch

Cummins Intermountain
1435 East 335 South
P.O. Box 903
Vernal, UT 84078
Telephone: (801) 789-5732

Virginia

Richmond - (Branch of Charlotte)

Cummins Atlantic, Inc.
3900 Deepwater Terminal Road
Richmond, VA 23234
Telephone: (804) 232-7891

Roanoke - (Branch of Charlotte)

Cummins Atlantic, Inc.
5307 Peters Creek Road
P.O. Box 7237
Roanoke, VA 24019
Telephone: (703) 362-1673

Bristol - (Branch of Louisville)

Cummins Cumberland, Inc.
400 Stagecoach Road
1-81 at Old Airport Road
Bristol, VA 24201
Telephone: (703) 669-4200

Washington

Seattle - (Branch of Portland)

Cummins Northwest, Inc.
811 S.W. Grady Way
P.O. Box 9811/98057
Renton, WA 98055
Telephone: (206) 235-3400

Renton - (Industrial Branch of Portland)

Cummins Northwest, Inc.
Power Systems Division
811 S.W. Grady Way
P.O. Box 9811(98057)
Renton, WA 98055
Telephone: (206) 235-3400

Chehalis - (Branch of Portland)

Cummins Northwest, Inc.
1200 N.W. Maryland
P.O. Box 1363
Chehalis, WA 98532
Telephone: (206) 748-8841

Spokane - (Branch of Portland)

Cummins Northwest, Inc.
E. 3904 Trent Avenue
P.O. Box 2746 -
Terminal Annex
Spokane, WA 99220
Telephone: (509) 534-0411

Tacoma - (Branch of Portland)

Cummins Northwest, Inc.
1662 Lincoln Ave.
Tacoma, WA 98421
Telephone: (206) 572-9800

Yakima - (Branch of Portland)

Cummins Northwest, Inc.
1905 East Central Avenue
P.O. Box 9129
Yakima, WA 98909
Telephone: (509) 248-9033

Longview - (Branch of Portland)

Cummins Northwest, Inc.
1153 Third Avenue
P.O. Box 1459
Longview, WA 98632
Telephone: (206) 425-0100

West Virginia

Charleston - (Branch of Louisville)

Cummins Cumberland, Inc.
Charleston Ordnance Center
P.O. Box 8456
South Charleston, WV 25303
Telephone: (304) 744-6373

Fairmont - (Branch of Louisville)

Cummins Cumberland, Inc.
South Fairmont Exit, I-79
Rt. 73, South
P.O. Box 988
Fairmont, WV 26554
Telephone: (304) 367-0196

Wisconsin

Cummins Great Lakes, Inc.

Corporate Office
P.O. Box 530
De Pere, WI 54115
Telephone: (414) 337-1991/1992

De Pere Distributor

Cummins Great Lakes, Inc.
P.O. Box 530
Route #3, Hwy. 41
DePere, WI 54115
Telephone: (414) 336-9631

Chippewa Falls Branch

Cummins Great Lakes, Inc.
Highway 53 North, Route #7
Box Number 88
Chippewa Falls, WI 54729
Telephone: (715) 832-4329

Milwaukee Branch

Cummins Great Lakes, Inc.
1921 South 108th Street
P.O. Box 27096
Milwaukee, WI 53227
Telephone: (414) 543-3160

Wyoming

Casper - (Branch of Denver)

Cummins Power, Inc.
2000 E. "F" St.
P.O. Drawer 2560
Casper, WY 82602
Telephone: (307) 234-6685

Gillette - (Branch of Denver)

Cummins Power, Inc.
Hwy. 14 & 16 North
P.O. Box 1207
Gillette, WY 82716
Telephone: (307) 682-9611

Laramie - (Branch of Denver)

Cummins Power, Inc.
1967 Carroll Avenue
Laramie, WY 82070
Telephone: (307) 742-0321

Rock Springs - (Branch of Salt Lake City)

Cummins Intermountain
2000 Foothill Blvd.
P.O. Box 1634
Rock Springs, WY 82901
Telephone: (307) 362-5168

Distributors and Branches, Canada

Alberta

Edmonton Distributor

Cummins Alberta
14755 - 121A Avenue
Edmonton, Alberta T5L 2T2
Telephone: (403) 455-2151

Calgary Branch

Cummins Alberta
703-64 Avenue S.E.
Calgary, Alberta T2H 2C3
Telephone: (403) 255-6691

Hinton Branch

Cummins Alberta
146 Veats Avenue
Hinton, Alberta TOE 1B0
Telephone: (403) 865-5111

Lethbridge Branch

Cummins Alberta
230 - 24th Street North
Lethbridge, Alberta T1J 3N2
Telephone: (403) 329-6144

Medicine Hat Branch

Cummins Alberta
1651 Broadway Avenue, Redcliff
Medicine Hat, Alberta TOJ 2P0
Telephone: (403) 548-7300

British Columbia

Vancouver Distributor

Cummins British Columbia
4270 Dawson Street
Burnaby, B.C. V5C 4B1
Telephone: (604) 299-9111

Kamloops Branch

Cummins British Columbia
976 Laval Crescent
Kamloops, B.C. Canada V2C 5P5
Telephone: (604) 828-2388

Sparwood Branch

Cummins British Columbia
P.O. Box 1526
115 Elk Valley Road
Sparwood, B.C. VOB 2G0
Telephone: (604) 425-0522

Tumbler Ridge Branch

Cummins British Columbia
Box 226
Tumbler Ridge, B.C.
Canada VOC 2W0
Telephone: (604) 242-4217

Manitoba

Winnipeg Distributor

Cummins Mid-Canada Ltd.
489 Oak Point Road
P.O. Box 1860
Winnipeg, Manitoba R3C 3R1
Telephone: (204) 632-5470

New Brunswick

Fredericton - (Branch of Montreal)

Cummins Diesel (Division of
Cummins Quebec Ltee)
Vanier Highway
P.O. Box 1178, Station "A"
Fredericton,
New Brunswick E3B 5C8
Telephone: (506) 452-1940

Newfoundland

St. John's - (Branch of Montreal)

Cummins Diesel (Division of
Cummins Quebec Ltee)
Box 8056, Station "A"
Kenmount Road
St. John's,
Newfoundland A1B 3M7
Telephone: (709) 753-6972

Nova Scotia

Dartmouth - (Branch of Montreal)

Cummins Diesel (Division of
Cummins Quebec Ltee)
10 Morris Drive, Unit 31
Dartmouth,
Nova Scotia B3K 5M1
Telephone: (902) 463-3500

Halifax - (Branch of Montreal)

Cummins Diesel (Division of
Cummins Quebec Ltee)
3204 Barrington Street
Halifax, Nova Scotia B3K 2X6
Telephone: (902) 429-1440

Ontario

Toronto Distributor

Cummins Ontario Ltd.
150 N. Queen Street
P.O. Box 40, Station "U"
Toronto, Ontario M8Z 5N1
Telephone: (416) 621-9921

Oakville Industrial Branch

Cummins Ontario Ltd.
301 Wycroft Road
Oakville, Ontario L6K 2H2
Telephone: (416) 844-5851

Thunder Bay Branch

Cummins Ontario Ltd.
1400 W. Walsh Street
Thunder Bay
Ontario P7C 4V9
Telephone: (807) 577-7561

Whitby Branch

Cummins Ontario Limited
1311 Hopkins Street
Whitby, Ontario L1N 2C2
Telephone: (416) 668-6886

Cardinal - (Branch of Montreal)

Cummins Diesel (Division of
Cummins Quebec Ltee)
Highway 401 and Shanley Road
Cardinal, Ontario K0E 1E0
Telephone: (613) 657-3139/30

Ottawa - (Branch of Toronto)

Cummins Ontario Ltd.
3189 Swansea Crescent
Hawthorne Industrial Park
Ottawa, Ontario K1G 3W5
Telephone: (613) 521-1146

Quebec

Montreal Distributor

Cummins Quebec Ltee
7200 Trans Canada Highway
Pointe Claire, Quebec H9R 1C2
Telephone: (514) 695-8410

Montreal Branch

Cummins Quebec Ltee
7200 Trans Canada Highway
Pointe Claire, Quebec H9R 1C2
Telephone: (514) 695-8410
Sales: (514) 694-5143
Parts: (514) 694-5880

Quebec City Branch

Cummins Quebec Ltee
2400 Watt Street
Ste. Foy, Quebec G1P 3T3
Telephone: (418) 651-2911

Saskatchewan

Lloydminster - (Branch of Winnipeg)

Cummins Mid-Canada Ltd.
110 Kress Street
P.O. Box 959
Lloydminster, SK S9V 0Y9
Telephone: (403) 825-2062

Regina - (Branch of Winnipeg)

Cummins Mid-Canada Ltd.
110 Kress Street
P.O. Box 98
Regina, SK S4P 2Z5
Telephone: (306) 545-9710

Saskatoon - (Branch of Winnipeg)

Cummins Mid-Canada, Ltd.
4550 Idylwyld Drive North
P.O. Box 7679
Saskatoon,
Saskatchewan S7K 4R4
Telephone: (306) 933-4022

Distributors and Branches, Australia

Sydney (Lansvale)

Cummins Diesel Sales &
Service
P.O. Box 150
164-170 Hume Highway
Lansvale, 2166
Cabramatta 2166
New South Wales,
Australia
Telephone: (02) 728-6211

Branches:

Adelaide (Gepps Cross)

Cummins Diesel Sales &
Service
P.O. Box 108
45-49 Cavan Road
Gepps Cross, 5094
Blair Athol, 5084
South Australia, Australia
Telephone: (08) 262-5211

Brisbane (Darra)

Cummins Diesel Sales &
Service
P.O. Box 124
2506 Ipswich Road
Darra, 4076
Queensland, Australia
Telephone: (07) 375-3277

Darwin (Winnellie)

Cummins Diesel Sales &
Service
P.O. Box 37587
Lot 1758 Graffin Crescent
Winnellie, 5789
Winnellie, Darwin, 578
Northern Territory, Australia
Telephone: (089) 47-0766

Devonport

Cummins Diesel Sales &
Service
P.O. Box 72E
31-33 Don Road
East Devonport, 7310
Tasmania, Australia
Telephone: (004) 24-4466

Grafton (South Grafton)

Cummins Diesel Sales &
Service
P.O. Box 18
3 Hunter Street
South Grafton, 2461
New South Wales, Australia
Telephone: (006) 42-3655

Mackay

Cummins Diesel Sales &
Service
P.O. Box 842
4 Presto Avenue
Mackay, 4740
Queensland, Australia
Telephone: (079) 55-1222

Melbourne (Campbellfield)

Cummins Diesel Sales &
Service
Private Bag 9, G.P.O.
1788-1800 Hume Highway
Campbellfield 3061
Victoria, Australia
Telephone: (03) 359-5622

Mount Gambier

Cummins Diesel Sales & Service
P.O. Box 2219
2 Avey Road
Mount Gambier, 5290
South Australia, Australia
Telephone: (087) 25-6422

Newcastle (Sandgate)

Cummins Diesel Sales &
Service
Lot 66, Ayshire Crescent
Sandgate, 2034
New South Wales, Australia
Telephone: (049) 67-3088

Perth (Kewdale)

Cummins Diesel Sales &
Service
P.O. Box 275
50 Kewdale Road
Kewdale, 6105
Cloverdale, 6105
Western Australia, Australia
Telephone: (09) 458-5911

Swan Hill

Cummins Diesel Sales & Service
P.O. Box 1264
Balranald Road
Murray Down, NSW
Swan Hill, 3585
Victoria, Australia
Telephone: (050) 32-3037

Tamworth

Cummins Diesel Sales &
Service
P.O. Box 677
Lot 65 Gunnedah Road
Tamworth, 2340
New South Wales, Australia
Telephone: (067) 65-5455

Wodonga

Cummins Diesel Sales &
Service
P.O. Box 174
165 Hume Highway
Wodonga, 3690
Victoria, Australia
Telephone: (060) 24-3655

Distributors and Branches, New Zealand

Auckland

Lees Power
P.O. Box 12-444
440 Church Street
Penrose, Auckland,
New Zealand
Telephone: (9) 591-009

Branches:

Auckland

Lees Power
P.O. Box 12-120
440 Church Street
Penrose, Auckland,
New Zealand
Telephone: (9) 591-009

Christchurch

Lees Power
P.O. Box 16-149, Hornby
268 Main South Road
Sockburn, Christchurch,
New Zealand
Telephone: (3) 497-178

Dunedin

Lees Power
P.O. Box 7027, Mornington
Cnr. McBride & Broughton Streets
Mornington, Dunedin,
New Zealand
Telephone: (24) 52012

Hamilton

Lees Power
P.O. Box 8028, Melville
Kahikatea Drive
Melville, Hamilton,
New Zealand
Telephone: (71) 73-392

Invercargill

Lees Power
P.O. Box 1040
205 Bond Street
Invercargill, New Zealand
Telephone: (21) 44073

Napier

Lees Power
P.O. Box 3021, Onekawa
Austin Street
Onekawa, Napier,
New Zealand
Telephone: (70) 436-129

Nelson

Lees Power
P.O. Box 2076, Stoke
59 Quarantine Road
Nelson, New Zealand
Telephone: (54) 79-651

Palmerston North

Lees Power
P.O. Box 9024
852-860 Tremaine Avenue
Palmerston North,
New Zealand
Telephone: (63) 62-209

Rotorua

Lees Power
P.O. Box 934
Te Ngae Road
Rotorua, New Zealand
Telephone: (73) 56-699

Wellington

Lees Power
P.O. Box 30-447,
Port Road South
Seaview, Lower Hutt,
New Zealand
Telephone: (4) 686-029

Distributors and Dealers, Puerto Rico

Catano

Cummins Diesel Power, Inc.
Box CPR
San Patricio Plaza
Puerto Rico 00920
Location:
Calle C #31 El Matadero
Puerto Nuevo
Telephone: (809) 793-1072

Dealers:

Anasco

Truck & Tractor Parts
P.O. Box 1388
Anasco, Puerto Rico 00610
Telephone: (809) 834-6220

Bayamon

Heavy Parts Center
P.O. Box 3157
Empress, Losada
Bayamon, Puerto Rico 00621
Telephone: (809) 785-9190

Hato Tejas

(Actual Location:)
Kane Caribbean, Inc.
Carretera No. 2 Km 17
Hato Tejas, Puerto Rico

(Mailing Address:)
Kane Caribbean, Inc.
G.P.O. Box 2376
San Juan,
Puerto Rico 00936
Telephone: (809) 787-3030

Ponce

(Actual Address:)
Kane Caribbean, Inc.
Road No. 1
Across from Mercedita Airport
Ponce, Puerto Rico 00731

(Mailing Address:)
Kane Caribbean, Inc.
P.O. Box 4501
Ponce, Puerto Rico 00731
Telephone: (809) 843-9088

Ponce

Carlos Mesa Truck Supplies
P.O. Box 7552
170 Hostos Avenue
Ponce, Puerto Rico 00732
Telephone: (809) 843-0660

San Juan

Atlas Trading
G.P.O. Box 1345
Edificio c Mercado Central
San Juan, Puerto Rico 00936
Telephone: (809) 782-2064

San Juan

Guaraguao Truck Sales
P.O. Box 1340
Carr. 174 Km. 4.6
Ruta Estrella 165A
San Juan, Puerto Rico 00936
Telephone: (809) 782-2064

San Juan

Centro Lamiones
P.O. Box 11411
Caparra Heights Station
San Juan, Puerto Rico 00922
Telephone: (809) 782-8000

Component Manufacturers
C Series

United States and United Kingdom Offices
Page 7-1

Section 7 - Components Manufacturers

United States and United Kingdom Offices

Note: The following list contains addresses and telephone numbers of suppliers of accessories used on Cummins engines. Suppliers may be contacted directly for any specifications not covered in this manual.

Air Cylinders

Bendix Ltd.
Douglas Road
Kingswood
Bristol
England
Telephone: 0272-671881

Catching Engineering
2101 Roberts Drive
Broadview, IL 60153
Telephone: (312) 344-2334

Air Heaters

Fleetguard, Inc.
Route 8
Cookeville, TN 38501
Telephone: (615) 526-9551

Kim Hotstart Co.
West 917 Broadway
Spokane, WA 99210
Telephone: (509) 534-6171

Air Starters

Ingersoll Rand
Chorley New Road
Horwich
Bolton
Lancashire
England
BL6 6JN
Telephone: 0204-65544

Ingersoll-Rand Engine
Starting Systems
888 Industrial Drive
Elmhurst, IL 60126
Telephone: (312) 530-3800

Start Master
Air Starting Systems
A Division of Sycon Corporation
P. O. Box 491
Marion, Ohio 43302
Telephone: (614) 382-5771

Alternators

Robert Bosch Ltd.
P.O. Box 98
Broadwater Park
North Orbital Road
Denham
Uxbridge
Middlesex UD9 5HG
England
Telephone: 0895-833633

Butec Electrics
Cleveland Road
Leyland
PR5 1XB
England
Telephone: 0744-21663
C.A.V. Electrical Equipment
P.O. Box 36
Warple Way
London
W3 7SS
England
Telephone: 01-743-3111

A.C. Delco Components Group
Civic Offices
Central Milton Keynes
MK9 3EL
England
Telephone: 0908-66001

Delco-Remy
P.O. Box 2439
Anderson, IN 46018
Telephone: (317) 646-7838

Leece-Neville Corp.
1374 E. 51st St.
Cleveland, OH 44013
Telephone: (216) 431-0740

Belts

Dayco Rubber U.K.
Sheffield Street
Stockport
Cheshire
SK4 1RV
England
Telephone: 061-432-5163

T.B.A. Ind. Products
P.O. Box 77
Wigan
Lancashire
WN2 4XQ
England
Telephone: 0942-59221

Dayco Corp.
Belt Technical Center
P.O. Box 3258
Springfield, MO 65804
Telephone: (417) 881-7440

Gates Rubber Company
5610 Crawfordsville Road
Suite 2002
Speedway, IN 46224
Telephone: (317) 248-0386

Goodyear Tire and
Rubber Company
49 South Franklin Road
Indianapolis, IN 46219
Telephone: (317) 898-4170

Clutches

Twin Disc International S.A.
Chaussee de Namur
Nivelles
Belguim
Telephone: 067-224941

Twin Disc Clutch Co.
Racine, WI 53403
Telephone: (414) 634-1981

Coolant Heaters

Fleetguard, Inc.
Route 8
Cookeville, TN 38501
Telephone: (615) 526-9551

Drive Plates

Detroit Diesel Allison
Division of General Motors
Corporation
P.O. Box 894
Indianapolis, IN 46206
Telephone: (317) 244-1511

Electric Starters

Butec Electrics
Cleveland Road
Leyland
PR5 1XB
England
Telephone: 0744-21663

C.A.V. Electrical Equipment
P.O. Box 36
Warple Way
London
W3 7SS
England
Telephone: 01-743-3111

A.C. Delco Components Group
Civic Offices
Central Milton Keynes
MK9 3EL
England
Telephone: 0908-66001

Delco-Remy
P.O. Box 2439
Anderson, IN 46018
Telephone: (317) 646-7838

Component Manufacturers C Series

Leece-Neville Corp.
1374 E. 51st Street
Cleveland, OH 44013
Telephone: (216) 431-0740

Fans

Trufflo Ltd.
Westwood Road
Birmingham
B6 7JF
England
Telephone: 021-557-4101

Hayes-Albion
1999 Wildwood Avenue
Jackson, MI 49202
Telephone: (517) 782-9421

Engineering Cooling Systems
201 W. Carmel Drive
Carmel, IN 46032
Telephone: (317) 846-3438

Brookside
McCordsville, IN 46055
Telephone: (317) 873-5093

Aerovent
8777 Purdue Rd.
Indianapolis, IN 46268
Telephone: (317) 872-0030

Kysor
1100 Wright Street
Cadillac, MI 49601
Telephone: (616) 775-4681

Schwitzer
1125 Brookside Avenue
P.O. Box 80-B
Indianapolis, IN 46206
Telephone: (317) 269-3100

Fan Clutches

Holset Engineering Co. Ltd.
P.O. Box 9
Turnbridge
Huddersfield
England
Telephone: 0484-22244

Rockford Division
Borg-Warner Corporation
1200 Windsor Road
P.O. Box 7007
Rockford, IL 61125-7007
Telephone: (815) 633-7460

Filters

Fleetguard International Corp.
Cavalry Hill Industrial Park
Weedon
Northampton NN7 4TD
England
Telephone: 0327-41313

Fleetguard, Inc.
Route 8
Cookeville, TN 38501
Telephone: (615) 526-9551

United States and United Kingdom Offices Page 7-3

Flexplates

Corrugated Packing and
Sheet Metal
Hamsterley
Newcastle Upon Tyne
Telephone: 0207-560-505

Detroit Diesel Allison
Division of General Motors
Corporation
P.O. Box 894
Indianapolis, IN 46206
Telephone: (317) 244-1511

Detroit Diesel Allison
Division of General Motors
36501 Van Born Road
Romulus, MI 48174
Telephone: (313) 595-5711

Midwest Mfg. Co.
30161 Southfield Road
Southfield, MI 48076
Telephone: (313) 642-5355

Fuel Warmers

Fleetguard, Inc.
Route 8
Cookeville, TN 38501
Telephone: (615) 526-9551

Gauges

A.I.S.
Dyffon Industrial Estate
Ystrad Mynach
Hengoed
Mid Glamorgan
CF8 7XD
England
Telephone: 0443-812791

Grasslin U.K. Ltd.
Vale Rise
Tonbridge
Kent
TN9 1TB
England
Telephone: 0732-359888

Icknield Instruments Ltd.
Jubilee Road
Letchworth
Herts
England
Telephone: 04626-5551

Superb Tool and Gauge Co.
21 Princip Street
Birmingham
B4 61E
England
Telephone: 021-359-4876

Kabi Electrical and Plastics
Cranborne Road
Potters Bar
Herts
EN6 3JP
England
Telephone: 0707-53444

Datcon Instrument Co.
P.O. Box 128
East Petersburg, PA 17520
Telephone: (717) 569-5713

Rochester Gauge of Texas
11637 Denton Drive
Dallas, TX 75229
Telephone: (214) 241-2161

Governors

Woodward Governors Ltd.
P.O. Box 15
663/664 Ajax Avenue
Slough
Bucks
SL1 4DD
England
Telephone: 0753-26835

Woodward Governor Co.
1000 E. Drake Road
Fort Collins, CO 80522
Telephone: (303) 482-5811

Barber Colman Co.
1300 Rock Street
Rockford, IL 61101
Telephone: (815) 877-0241

United Technologies
Diesel Systems
1000 Jorie Blvd.
Oak Brook, IL 60521
Telephone: (312) 325-2020

Hydraulic and Power Steering Pumps

Hobourn Eaton Ltd.
Priory Road
Strood
Rochester
Kent
ME2 2BD
Telephone: 0634-71773

Honeywell Control Systems Ltd.
Honeywell House
Charles Square
Bracknell
Berks RG12 1EB
Telephone: 0344-424555

Sundstrand Hydratec Ltd.
Cheney Manor Trading Estate
Swindon
Wiltshire
SN2 2PZ
England
Telephone: 0793-30101

Sperry Vickers
1401 Crooks Road
Troy, MI 48084
Telephone: (313) 280-3000

Component Manufacturers C Series

Z.F.
P.O. Box 1340
Grafvonsoden Strasse
5-9 D7070
Schwaebisch Gmuend
West Germany
Telephone: 7070-7171-31510

Oil Heaters

Fleetguard, Inc.
Route 8
Cookeville, TN 38501
Telephone: (615) 526-9551

Kim Hotstart Co.
West 917 Broadway
Spokane, WA 99210
Telephone: (509) 534-6171

Safety Controls

Teddington Industrial
Equipment
Windmill Road
Sunburn on Thames
Middlesex
TW16 7HF
England
Telephone: 09327-85500

The Nason Company
10388 Enterprise Drive
Davisburg, MI 48019
Telephone: (313) 625-5381

Torque Converters

Twin Disc International S.A.
Chaussee de Namur
Nivelles
Belgium
Telephone: 067-224941

Twin Disc Clutch Co.
Racine, WI 53403
Telephone: (414) 634-1981

Rockford Division
Borg-Warner Corporation
1200 Windsor Road
P.O. Box 7007
Rockford, IL 61125-7007
Telephone: (815) 633-7460

Modine
1500 DeKoven Avenue
Racine, WI 53401
Telephone: (414) 636-1640

Section 8 - Service Literature

Table of Contents

Subject	Page
Available Service Literature Listing.....	8-2
Literature Ordering Locations	8-3
Literature Order Form.....	8-5
Literature Order Shipping Label.....	8-6

Additional Service Literature
Page 8-2

Service Literature
C Series

Additional Service Literature

The following publications can be purchased by filling in and mailing the Service Literature Order Form:

Bulletin No.	Title Of Publication	Price (U.S. \$)*
3810261	Troubleshooting and Repair Manual	\$16.00
3810275	C Series Engine Shop Manual	\$16.00
3822026	C Series Engine Parts Catalog	\$ 5.50

* Prices subject to change without notice.

Service Literature Ordering Location

Order service literature from your nearest regional location; refer to the addresses listed below:

REGION	ORDERING LOCATION
United States and Canada	Literature Control Service 3400 Robards Court P. O. Box 34470 Louisville, Kentucky 40232-4470
U.K., Europe, Mid-East, Africa and Eastern European Countries	Cummins Daventry Royal Oak Way South Northants, England NN11 5 NU
South and Central America (excluding Brazil and Mexico)	Cummins Americas, Inc. 16085 Northwest 52nd Avenue Hialeah, Florida 33104
Brazil and Mexico	International Parts Order Dept. Cummins Engine Company Columbus, Indiana 47202 Mail Code 40931
Far East (excluding Australia and New Zealand)	Cummins Diesel Sales Corp. Literature Center 100-G Pasir Panjang Road Singapore 0511

Service Literature Ordering Location(Continued)

REGION	ORDERING LOCATION
Australia and New Zealand	Cummins Diesel Australia Maroondah Highway, P.O.B. 139 Ringwood 3134 Victoria, Australia

Service Literature Order Form

Use this form for prompt handling of your literature order.

Bulletin Number	Literature Description	Quantity	U.S. Price Each	Amount
			Subtotal	
			Indiana Residents add 5% sales tax	
			Total	

Payment enclosed. Make certified check or money order payable to Cummins Engine Company, Inc.

FROM:

Name: _____
 Street Address: _____
 City: _____ State: _____ Zip Code: _____
 Country: _____

SHIP TO: (Name and address where literature is to be shipped)

Name: _____
 Street Address: _____
 City: _____ State: _____ Zip Code: _____
 Country: _____

Abbreviations Used In This Manual	0-4	Drive Belt - Inspection	2-9
About the Manual	0-2	Fan - Inspection	2-8
Additional Service Literature	8-2	Fuel-Water Separator - Draining Water and Sediment	2-9
Air System Repair	4-49	Oil Level - Checking	2-7
Aftercooler and Gasket - Replacement	4-52	DCA4 Unit Maintenance Guide	5-19
Air Compressor - Replacement	4-67	Directory - Division and Regional Offices	6-4
Air Crossover Tube - Replacement	4-49	Australia Regional Office	6-4
Exhaust Manifold and Gaskets - Replacement	4-65	Canada	6-4
Intake Manifold Cover and Gasket - Replacement	4-50	Cummins Americas Regional Office	6-4
Preparatory Steps:	4-67	United States	6-4
Turbocharger - Replacement	4-56	Distributors and Branches, Australia	6-22
Air System Repair Summary	4-48	Branches:	6-22
C Series Engine Maintenance Schedule	2-3	Sydney (Lansvale)	6-22
C Series Lubricants	5-8, 5-9	Distributors and Branches, Canada	6-19
C Series Sealants	5-7	Alberta	6-19
California Emission Control System Warranty	i-11	British Columbia	6-19
Capscrew Markings and Torque Values	5-15	Manitoba	6-19
Cold Weather Starting Aids	1-3	New Brunswick	6-19
Cold Weather Starting With Starting Fluid	1-4	Newfoundland	6-19
With Mechanical Or Electrical Metering Equipment	1-4	Nova Scotia	6-20
Without Metering Equipment	1-4	Ontario	6-20
Cooling System Repair	4-5	Quebec	6-20
Belt Tensioner - Replacement	4-5	Saskatchewan	6-20
Drive Belt - Replacement	4-5	Distributors and Branches, New Zealand	6-23
Fan Pulley - Replacement	4-7	Auckland	6-23
Thermostat - Replacement	4-13	Branches:	6-23
Water Pump - Replacement	4-8	Distributors and Branches, United States	6-5
Cooling System Repair Summary	4-4	Alabama	6-5
Crankshaft Seal Repair	4-87	Alaska	6-5
Front Crankshaft Seal - Replacement	4-87	Arizona	6-5
Rear Crankshaft Seal - Replacement	4-91	Arkansas	6-5
Crankshaft Seal Repair Summary	4-86	California	6-5
Cummins Warranty - Automotive	i-7	Colorado	6-6
Cummins Warranty - Worldwide Industrial and Marine	i-17	Connecticut	6-6
Cummins Warranty - Worldwide Mobile Farming Equipment	i-14	Florida	6-6
Daily Maintenance	2-7	Georgia	6-7
Coolant Level - Checking	2-8	Hawaii	6-7

Index

Page 9-2

Idaho	6-7	Catano	6-24
Illinois	6-7	Dealers:	6-24
Indiana	6-8	Electrical System Repair	4-97
Iowa	6-8	Alternator - Replacement	4-98
Kansas	6-8	Starting Motor - Replacement	4-97
Kentucky	6-8	Electrical System Repair Summary	4-96
Louisiana	6-9	Emergency Service Assistance	6-2
Maine	6-9	Engine Component Torque Value	5-2, 5-3, 5-4, 5-5, 5-6
Maryland	6-9	Engine Dataplate	0-10
Massachusetts	6-9	Engine Specifications	5-10
Michigan	6-9	Air Starter Maintenance	5-13
Minnesota	6-10	Air Starters	5-13
Mississippi	6-10	Cooling	5-11
Missouri	6-10	Fuel	5-11
Montana	6-11	General	5-10
Nebraska	6-11	Intake	5-11
Nevada	6-11	Lubrication	5-10
New Jersey	6-11	Minimum Recommended Battery Capacity	5-12
New Mexico	6-11	Engine System Diagrams	3-2
New York	6-11	Air System	3-9
North Carolina	6-12	Coolant System	3-7, 3-8
North Dakota	6-12	Fuel System	3-10
Ohio	6-13	Lubricating Oil System	3-3
Oklahoma	6-13	Lubrication for the Overhead	3-6
Oregon	6-14	Lubrication for the Power Components	3-5
Pennsylvania	6-14	Lubrication for the Turbocharger	3-4
South Carolina	6-15	External Engine Components	0-12
South Dakota	6-15	Front View	0-16
Tennessee	6-15	Fuel Pump Side View	0-13
Texas	6-15	Rear View	0-14
Utah	6-16	Turbocharger Side View	0-15
Virginia	6-16	Fuel Pump Dataplate (Nameplate)	0-11
Washington	6-17	Fuel System Repair	4-21
West Virginia	6-17	Fuel Drain Manifold - Replacement	4-27
Wisconsin	6-17	Fuel Filter Head Adapter - Replacement	4-23
Wyoming	6-18	Fuel Pump - Replacement	4-35
Distributors and Dealers, Puerto Rico	6-24	Fuel Shut Off Solenoid - Replacement	4-33

Fuel System Components - Cleaning	4-21	Maintenance Required At Every 64,000 KM	2-35
High Pressure Fuel Lines - Replacement	4-26	Air Compressor - Inspection	2-41
Idle Speed - Adjustment	4-45	Coolant Change and Flushing the System	2-35
Injectors - Replacement	4-29	Vibration Damper - Inspection	2-40
Lift Pump - Replacement	4-24	Maintenance Schedule	2-2
Low Pressure Fuel Line - Replacement	4-21	Maintenance Tools Required	2-6
Fuel System Repair Summary	4-20	Metric Capscrew Nomenclature	5-14
General	1-2	Normal Starting Procedure	1-2
General Safety Precautions and Warnings	0-6	Operating the Engine	1-5
General Safety Precautions and Warnings	0-7	Operation and Maintenance Manual	0-1
How To Identify Your Engine	0-9	Prevent Engine Overspeed	1-6
Illustrations	0-5	Problem Solving Assistance:	6-3
Lubricant, Fuel and Coolant Specifications	5-16	Procedures	4-2
Coolant	5-18	Symbols	4-2
Engine Lubricating Oil	5-16	Repair Tools Required	4-3
Fuel	5-18	Routine Service Assistance	6-2
Lubricating System Repair	4-75	Service Literature Order Form	8-5
Oil Cooler Element and Gasket - Replacement	4-76	Service Literature Ordering Location	8-3
Oil Pan, Suction Tube and Gaskets - Replacement	4-81	Service Literature Ordering Location(Continued)	8-4
Oil Pressure Regulator, Valve and Spring - Replacement	4-75	Symbols	0-3
Lubricating System Repair Summary	4-74	Table of Contents	9-5
Maintenance Required At 33,000 KM	2-25	Subject	0-1
Drive Belt Tension - Check	2-32	To the Engine Owner and Operator	0-8
Drive Belt, Tensioner Bearing and Fan Hub - Inspection	2-33	Torque Specification	5-14
Valves - Adjustment	2-25	Troubleshooting Charts	3-12
Maintenance Required at Each 16,000 KM	2-17	Alternator Not Charging or Insufficient Charging	3-39
Antifreeze Concentration - Check	2-21	Contaminated Coolant	3-27
Coolant Additive Concentration - Check	2-21	Contaminated Lube Oil	3-28
Coolant Filter - Replacement	2-23	Coolant Loss	3-25
Coolant Filter/DCA4 Corrosion Resistor Cartridge	2-22	Coolant Temperature Above Normal	3-23
Fuel Filter - Replacement	2-17	Coolant Temperature Above Normal (Continued)	3-24
High Pressure Lines - Venting	2-20	Coolant Temperature Below Normal	3-26
Low Pressure Lines and Fuel Filter(s) - Venting	2-19	Engine Cranks, But Will Not Start - No Smoke From Exhaust	3-15
Maintenance Required at Each 8,000 KM	2-10	Engine Hard to Start or Will Not Start (Exhaust Smoke Present)	3-14
Air Cleaner Element - Inspection	2-16	Engine Misfiring	3-34
Air Intake System - Inspection	2-15	Engine Starts But Will Not Keep Running	3-16
Lubricating Oil and Filter - Change Interval	2-10		

Index

Page 9-4

Engine Surges at Idle	3-19
Engine Will Not Crank or Cranks Slowly	3-13
Engine Will Not Reach Rated Speed When Loaded	3-31
Engine Will Not Shut Off	3-17
Excessive Engine Noises	3-38
Excessive Fuel Consumption	3-36
Excessive Vibration	3-37
Exhaust Smoke Excessive Under Load	3-30
Fuel Knock	3-35
Fuel or Oil Leaking from Exhaust Manifold	3-29
Low Power	3-32
Low Power (Continued)	3-33
Lube Oil Loss	3-22
Lubricating Oil Pressure Low	3-20
Lubricating Oil Pressure Too High	3-21
Rough Idle, Warm Engine	3-18
Symptoms List	3-12
Troubleshooting Guide For The Operator	3-11
United States and United Kingdom Offices	7-1
Air Cylinders	7-1
Air Heaters	7-1
Air Starters	7-1
Alternators	7-1
Belts	7-2
Clutches	7-2
Coolant Heaters	7-2
Drive Plates	7-2
Electric Starters	7-2
Fan Clutches	7-3
Fans	7-3
Filters	7-3
Flexplates	7-3
Fuel Warmers	7-3
Gauges	7-4
Governors	7-4
Hydraulic and Power Steering Pumps	7-4
Oil Heaters	7-5

Safety Controls	7-5
Torque Converters	7-5

Cummins Engine Company, Inc.
Box 3005
Columbus, Indiana 47202-3005

Printed in U.S.A.
Bulletin 3810248-03