

Operation and Maintenance Manual G8.3 Series Engine

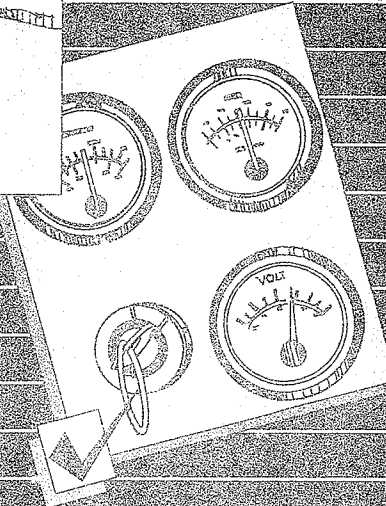

Cummins Customer Assistance Center
1-800-DIESELS (1-800-343-7357)
APPLICABLE ONLY IN U.S.A. AND CANADA

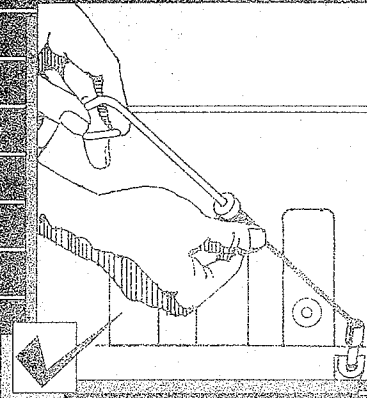

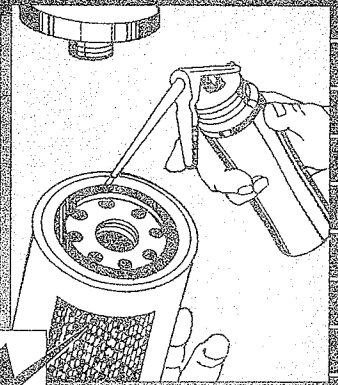
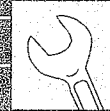
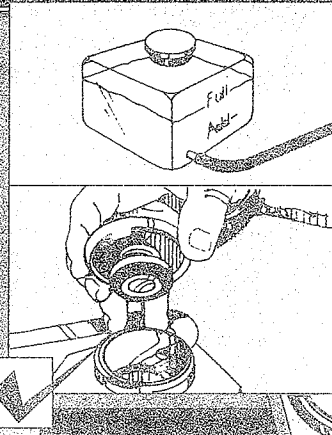
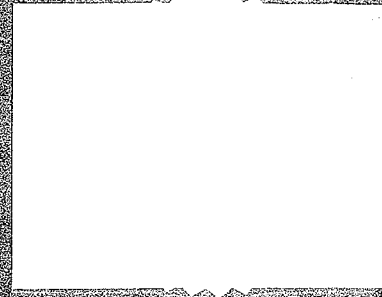

Operation and Maintenance Manual G8.3 Series Engine

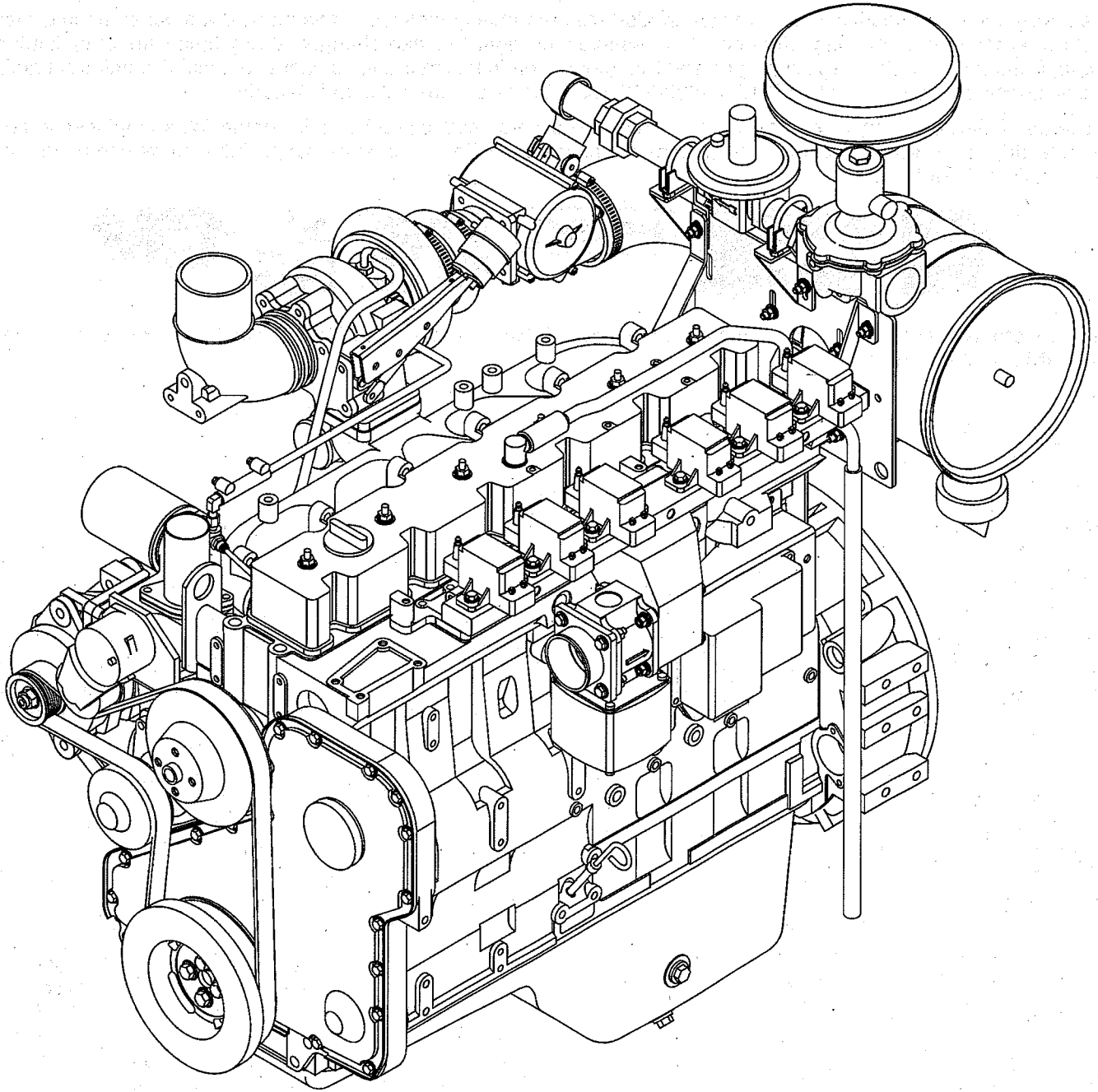

Copyright© 2004
Cummins Inc.
All rights reserved

00900399
Bulletin 4021489
Printed 16-SEPTEMBER-2004

Foreword

This manual contains information for the correct operation and maintenance of your Cummins engine. It also includes important safety information, engine and systems specifications, troubleshooting guidelines, and listings of Cummins Authorized Repair Locations and component manufacturers.

Read and follow all safety instructions. Refer to the WARNING in the General Safety Instructions in Section i - Introduction.

Keep this manual with the equipment. If the equipment is traded or sold, give the manual to the new owner.

The information, specifications, and recommended maintenance guidelines in this manual are based on information in effect at the time of printing. Cummins Inc. reserves the right to make changes at any time without obligation. If you find differences between your engine and the information in this manual, contact your local Cummins Authorized Repair Location or call 1-800-DIESELS (1-800-343-7357) toll free in the U.S. and Canada.

The latest technology and the highest quality components were used to produce this engine. When replacement parts are needed, we recommend using only genuine Cummins or ReCon® exchange parts. These parts can be identified by the following trademarks:



NOTE: Note: Warranty information is located in Section W. Make sure you are familiar with the warranty or warranties applicable to your engine.



NO POSTAGE
NECESSARY
IF MAILED
IN THE
UNITED STATES

BUSINESS REPLY MAIL

FIRST CLASS PERMIT NO. 15, COLUMBUS INDIANA

—POSTAGE WILL BE PAID BY ADDRESSEE—

Cummins Inc.
Product Registration Dept. (CAC)
P O Box 3005 M/C 91200
Columbus, IN 47202-3005

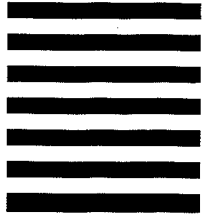

In order to serve you better it is very important that you fill out and return this card **within** 30 days of purchase.

Customer Name _____

Address _____

City / State _____

Zip Code _____

Home Phone Number (____) _____

Truck Phone / Cell Phone (____) _____

E-mail Address _____

Engine Serial Number _____

Date Purchased ____/____/____ VIN # _____

THANK YOU!!

Table of Contents

	Section
Introduction	i
Engine and System Identification	E
Operating Instructions	1
Maintenance Guidelines	2
Maintenance Procedures at Daily Interval	3
Maintenance Procedures at 250 Hours or 3 Months	4
Maintenance Procedures at 750 Hours or 6 Months	5
Maintenance Procedures at 1500 Hours or 1 Year	6
Maintenance Procedures at 6000 Hours or 2 Years	7
Adjustment, Repair, and Replacement	A
System Diagrams	D
Service Literature	L
Component Manufacturers	M
Service Assistance	S
Troubleshooting Symptoms	TS
Maintenance Specifications	V
Warranty	W

Important Reference Numbers

Fill in the part name and number in the blank spaces provided below. This will give you a reference whenever service or maintenance is required.

Part Name	Part Number	Part Number
Engine Model		
Engine Serial Number (ESN)		
Control Parts List (CPL)		
Fuel Pump Part Number		
Electronic Control Module (ECM)		
Electronic Control Module Serial Numbers (ECM)		
Filter Part Numbers:		
• Air Cleaner Element		
• Lubricating Oil Filter		
• Fuel		
• Fuel-Water Separator		
• Coolant		
• Remote Gas		
Governor Control Module (GCM) (if applicable)		
Belt Part Numbers:		
•		
•		
•		
Clutch or Marine Gear (if applicable):		
• Model		
• Serial Number		
• Part Number		
• Oil Type		
• Sea Water Pump		
- Model		
- Part Number		

Section i - Introduction

Section Contents

	Page
About the Manual	i-2
General Information.....	i-2
Acronyms and Abbreviations	i-12
General Information.....	i-12
General Cleaning Instructions	i-8
Abrasive Pads and Abrasive Paper.....	i-8
Definition of Clean.....	i-8
Gasket Surfaces.....	i-9
Plastic Bead Cleaning.....	i-10
Solvent and Acid Cleaning.....	i-9
Steam Cleaning.....	i-10
General Repair Instructions	i-7
General Information.....	i-7
Welding on a Vehicle with an Electronic Controlled Fuel System.....	i-7
General Safety Instructions	i-6
Important Safety Notice.....	i-6
How to Use the Manual	i-3
General Information.....	i-3
Illustrations	i-5
General Information.....	i-5
Symbols	i-4
General Information.....	i-4
To the Owner and Operator	i-1
General Information.....	i-1

This Page Left Intentionally Blank

To the Owner and Operator

General Information

Preventive maintenance is the easiest and least expensive type of maintenance. Follow the maintenance schedule recommendations outlined in Maintenance Guidelines (Section 2).

Keep records of regularly scheduled maintenance.

Use the correct fuel, lubricating oil, and coolant in your engine as specified in Maintenance Specifications (Section V).

Cummins Inc. uses the latest technology and the highest quality components to produce its engines. Cummins Inc. recommends using genuine Cummins new parts and ReCon® exchange parts.

Personnel at Cummins Authorized Repair Locations have been trained to provide expert service and parts support. If you have a problem that can **not** be resolved by a Cummins Authorized Repair Location, follow the steps outlined in the Service Assistance (Section S).

Product coverage, warranty limitations and owner responsibilities are available in Warranty (Section W).

△CAUTION△

Disconnect both the positive (+) and negative (-) battery cables from the battery before welding on the vehicle. Attach the welder ground cable no more than 0.61 meters [2 feet] from the part being welded. Do not connect the ground cable of the welder to the ECM cooling plate or ECM. Welding on the engine or engine mounted components is not recommended.

About the Manual

General Information

This manual contains information needed to correctly operate and maintain your engine as recommended by Cummins Inc. For additional service literature and ordering locations, refer to Service Literature (Section L).

This manual does not cover vehicle, vessel, or equipment maintenance procedures. Consult the original vehicle, vessel, or equipment manufacturer for specific maintenance recommendations.

Both metric and U.S. customary values are listed in this manual. The metric value is listed first, followed by the U.S. customary in brackets.

Numerous illustrations and symbols are used to aid in understanding the meaning of the text. Refer to Symbols in this section for a complete listing of symbols and their definitions.

Each section of the manual is preceded by a Section Contents to aid in locating information.

How to Use the Manual

General Information

This manual is organized according to intervals at which maintenance on your engine is to be performed. A maintenance schedule, that states the required intervals and maintenance checks, is located in Maintenance Guidelines (Section 2). Locate the interval at which you are performing maintenance; then follow the steps given in that section for all the procedures to be performed.

Keep a record of all the checks and inspections made. A maintenance record form is located in Maintenance Guidelines (Section 2).

Engine troubleshooting procedures for your engine are located in Troubleshooting Symptoms (Section TS).

Specifications for your engine are located in Maintenance Specifications (Section V).

Symbols

General Information

The following symbols have been used in this manual to help communicate the intent of the instructions. When one of the symbols appears, it conveys the meaning defined below:



WARNING - Serious personal injury or extensive property damage can result if the warning instructions are not followed.



CAUTION - Minor personal injury can result or a part, an assembly, or the engine can be damaged if the caution instructions are not followed.



Indicates a **REMOVAL** or **DISASSEMBLY** step.



Indicates an **INSTALLATION** or **ASSEMBLY** step.



INSPECTION is required.



CLEAN the part or assembly.



PERFORM a mechanical or time **MEASUREMENT**.



LUBRICATE the part or assembly.



Indicates that a **WRENCH** or **TOOL SIZE** will be given.



TIGHTEN to a specific torque.



PERFORM an electrical **MEASUREMENT**.



Refer to another location in this manual or another publication for additional information.



The component weighs 23 kg [50 lb] or more. To avoid personal injury, use a hoist or get assistance to lift the component.

Illustrations

General Information

Some of the illustrations throughout this manual are generic and will not look exactly like the engine or parts used in your application. The illustrations can contain symbols to indicate an action required and an acceptable or not acceptable condition.

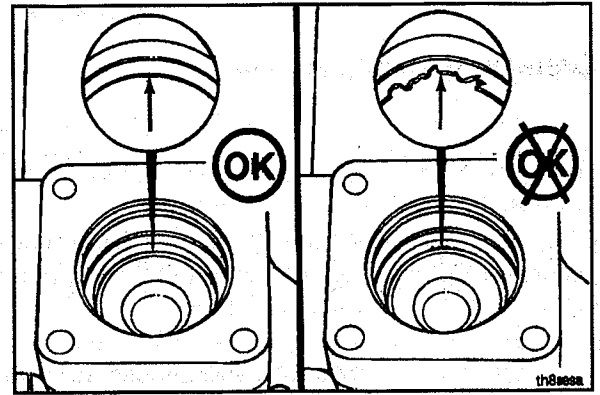

The illustrations are intended to show repair or replacement procedures. The procedure will be the same for all applications, although the illustration can differ.

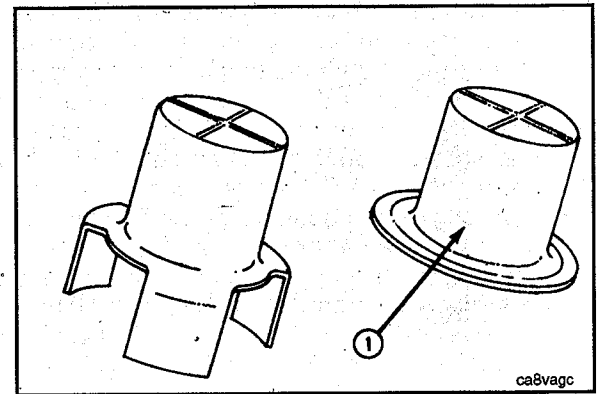

General Safety Instructions

Important Safety Notice



Improper practices, carelessness, or ignoring the warnings can cause burns, cuts, mutilation, asphyxiation or other personal injury or death.

Read and understand all of the safety precautions and warnings before performing any repair. This list contains the general safety precautions that **must** be followed to provide personal safety. Special safety precautions are included in the procedures when they apply.

- Work in an area surrounding the product that is dry, well lit, ventilated, free from clutter, loose tools, parts, ignition sources and hazardous substances. Be aware of hazardous conditions that can exist.
- **Always** wear protective glasses and protective shoes when working.
- Rotating parts can cause cuts, mutilation or strangulation.
- Do **not** wear loose-fitting or torn clothing. Remove all jewelry when working.
- Disconnect the battery (negative [-] cable first) and discharge any capacitors before beginning any repair work. Disconnect the air starting motor if equipped to prevent accidental engine starting. Put a "Do Not Operate" tag in the operator's compartment or on the controls.
- Use **ONLY** the proper engine barring techniques for manually rotating the engine. Do **not** attempt to rotate the crankshaft by pulling or prying on the fan. This practice can cause serious personal injury, property damage, or damage to the fan blade(s) causing premature fan failure.
- If an engine has been operating and the coolant is hot, allow the engine to cool before slowly loosening the filler cap to relieve the pressure from the cooling system.
- **Always** use blocks or proper stands to support the product before performing any service work. Do **not** work on anything that is supported **ONLY** by lifting jacks or a hoist.
- Relieve all pressure in the air, oil, fuel, and cooling systems before any lines, fittings, or related items are removed or disconnected. Be alert for possible pressure when disconnecting any device from a system that utilizes pressure. Do **not** check for pressure leaks with your hand. High pressure oil or fuel can cause personal injury.
- To reduce the possibility of suffocation and frostbite, wear protective clothing and **ONLY** disconnect liquid refrigerant (Freon) lines in a well ventilated area. To protect the environment, liquid refrigerant systems **must** be properly emptied and filled using equipment that prevents the release of refrigerant gas (fluorocarbons) into the atmosphere. Federal law requires capturing and recycling refrigerant.
- To reduce the possibility of personal injury, use a hoist or get assistance when lifting components that weigh 23 kg [50 lb] or more. Make sure all lifting devices such as chains, hooks, or slings are in good condition and are of the correct capacity. Make sure hooks are positioned correctly. **Always** use a spreader bar when necessary. The lifting hooks **must not** be side-loaded.
- Corrosion inhibitor, a component of SCA and lubricating oil, contains alkali. Do **not** get the substance in eyes. Avoid prolonged or repeated contact with skin. Do **not** swallow internally. In case of contact, immediately wash skin with soap and water. In case of contact, immediately flood eyes with large amounts of water for a minimum of 15 minutes. **IMMEDIATELY CALL A PHYSICIAN. KEEP OUT OF REACH OF CHILDREN.**
- Naptha and Methyl Ethyl Ketone (MEK) are flammable materials and **must** be used with caution. Follow the manufacturer's instructions to provide complete safety when using these materials. **KEEP OUT OF REACH OF CHILDREN.**
- To reduce the possibility of burns, be alert for hot parts on products that have just been turned off, and hot fluids in lines, tubes, and compartments.
- **Always** use tools that are in good condition. Make sure you understand how to use the tools before performing any service work. Use **ONLY** genuine Cummins or Cummins ReCon® replacement parts.
- **Always** use the same fastener part number (or equivalent) when replacing fasteners. Do **not** use a fastener of lesser quality if replacements are necessary.
- Do **not** perform any repair when fatigued or after consuming alcohol or drugs that can impair your functioning.
- Some state and federal agencies in the United States of America have determined that used engine oil can be carcinogenic and can cause reproductive toxicity. Avoid inhalation of vapors, ingestion, and prolonged contact with used engine oil.
- Liquefied petroleum gas is heavier than air and can accumulate near the floor, in sumps, and low-lying areas.
- Natural gas is lighter than air and can accumulate under hood and awnings.
- To reduce the possibility of suffocation and frostbite, wear protective clothing and **ONLY** disconnect natural gas and liquefied petroleum gas lines in a well ventilated area.
- Coolant is toxic. If **not** reused, dispose of in accordance with local environmental regulations.

General Repair Instructions

General Information

This engine incorporates the latest technology at the time it was manufactured; yet, it is designed to be repaired using normal repair practices performed to quality standards.

- **Cummins Inc. does not recommend or authorize any modifications or repairs to engines or components except for those detailed in Cummins Service Information. In particular, unauthorized repair to safety-related components can cause personal injury or death. Below is a partial listing of components classified as safety-related:**

1. Air Compressor
2. Air Controls
3. Air Shutoff Assemblies
4. Balance Weights
5. Cooling Fan
6. Fan Hub Assembly
7. Fan Mounting Bracket(s)
8. Fan Mounting Capscrews
9. Fan Hub Spindle
10. Flywheel
11. Flywheel Crankshaft Adapter
12. Flywheel Mounting Capscrews
13. Fuel Shutoff Assemblies
14. Fuel Supply Tubes
15. Lifting Brackets
16. Throttle Controls
17. Turbocharger Compressor Casing
18. Turbocharger Oil Drain Line(s)
19. Turbocharger Oil Supply Line(s)
20. Turbocharger Turbine Casing
21. Vibration Damper Mounting Capscrews

- **Follow all safety instructions noted in the procedures**

- Follow the manufacturer's recommendations for cleaning solvents and other substances used during the repair of the engine. Some solvents and used engine oil have been identified by government agencies as toxic or carcinogenic. Avoid excessive breathing, ingestion and contact with such substances. **Always** use good safety practices with tools and equipment.

- **Provide a clean environment and follow the cleaning instructions specified in the procedures**

- The engine and its components **must** be kept clean during any repair. Contamination of the engine or components will cause premature wear.

- **Perform the inspections specified in the procedures**

- **Replace all components or assemblies which are damaged or worn beyond the specifications**

- **Use genuine Cummins new or ReCon® service parts and assemblies**

- The assembly instructions have been written to use again as many components and assemblies as possible. When it is necessary to replace a component or assembly, the procedure is based on the use of new Cummins or Cummins ReCon® components. All of the repair services described in this manual are available from all Cummins Distributors and most Dealer locations.

- **Follow the specified disassembly and assembly procedures to reduce the possibility of damage to the components**

Complete rebuild instructions are available in the shop manual which can be ordered or purchased from a Cummins Authorized Repair Location. Refer to Section L — Service Literature for ordering instructions.

Welding on a Vehicle with an Electronic Controlled Fuel System

△CAUTION△

Disconnect both the positive (+) and negative (-) battery cables from the battery before welding on the vehicle. Attach the welder ground cable no more than 0.61 meters [2 feet] from the part being welded. Do not connect the ground cable of the welder to the ECM cooling plate or ECM. Welding on the engine or engine mounted components is not recommended or damage to the engine or components can result.

General Cleaning Instructions

Definition of Clean

Parts **must** be free of debris that can contaminate any engine system. This does **not** necessarily mean they have to appear as new.

Sanding gasket surfaces until the factory machining marks are disturbed adds no value and is often harmful to forming a seal. It is important to maintain surface finish and flatness tolerances to form a quality sealing surface. Gaskets are designed to fill small voids in the specified surface finish.

Sanding gasket surfaces where edge-molded gaskets are used is most often unnecessary. Edge-molded gaskets are those metal carriers with sealing material bonded to the edges of the gasket to seal while the metal portion forms a metal to metal joint for stability. Any of the small amounts of sealing material that can stick to the parts are better removed with a blunt-edged scraper on the spots rather than spending time polishing the whole surface with an air sander or disc.

For those gaskets that do **not** have the edge molding, nearly all have a material that contains release agents to prevent sticking. Certainly this is **not** to say that some gaskets are **not** difficult to remove because the gasket has been in place a long time, has been overheated or the purpose of the release agent has been defeated by the application of some sealant. The object however is just to remove the gasket without damaging the surfaces of the mating parts without contaminating the engine (don't let the little bits fall where they can not be removed).

Bead blasting piston crowns until the dark stain is removed is unnecessary. All that is required is to remove the carbon build-up above the top ring and in the ring grooves. There is more information on bead blasting and piston cleaning later in this document.

Cummins Inc. does **not** recommend sanding or grinding the carbon ring at the top of cylinder liners until clean metal is visible. The liner will be ruined and any signs of a problem at the top ring reversal point (like a dust-out) will be destroyed. It is necessary to remove the carbon ring to provide for easier removal of the piston assembly. A medium bristle, high quality, steel wire wheel that is rated above the rpm of the power tool being used will be just as quick and there will be less damage. Yes, one **must** look carefully for broken wires after the piston is removed but the wires are more visible and can be attracted by a magnet.

Oil on parts that have been removed from the engine will attract dirt in the air. The dirt will adhere to the oil. If possible, leave the old oil on the part until it is ready to be cleaned, inspected and installed, and then clean it off along with any attracted dirt. If the part is cleaned then left exposed it can have to be cleaned again before installation. Make sure parts are lubricated with clean oil before installation. They do **not** need to be oiled all over but do need oil between moving parts (or a good lube system priming process conducted before cranking the engine).

Bead blasting parts to remove exterior paint is also usually unnecessary. The part will most likely be painted again so all that needs happen is remove any loose paint.

Abrasive Pads and Abrasive Paper

The keyword here is "abrasive". There is no part of an engine designed to withstand abrasion. That is they are all supposed to lock together or slide across each other. Abrasives and dirt particles will degrade both functions.

WARNING

Abrasive material must be kept out of or removed from oil passages and parts wear points. Abrasive material in oil passages can cause bearing and bushing failures that can progress to major component damage beyond reuse. This is particularly true of main and rod bearings.

Cummins Inc. does **not** recommend the use of emery cloth or sand paper on any part of an **assembled** engine or component including but **not** limited to removing the carbon ridge from cylinder liners or to clean block decks or counterbores.

Great care **must** be taken when using abrasive products to clean engine parts, particularly on partially assembled engines. Abrasive cleaning products come in many forms and sizes. All of them contain aluminum oxide particles, silicon carbide, or sand or some other similar hard material. These particles are harder than most of the parts in the engine. Since they are harder, if they are pressed against softer material they will either damage the material or become embedded in it. These materials fall off the holding media as the product is used. If the products are used with power equipment the particles are thrown about the engine. If the particles fall between two moving parts, damage to the moving parts is likely.

If particles that are smaller than the clearance between the parts while they are at rest (engine stopped), but larger than the running clearance then damage will occur when the parts move relative to each other (engine started). While the engine is running and there is oil pressure, particles that are smaller than the bearing clearance are likely to pass

between the parts without damage and be trapped in the oil filter. However, particles larger than the bearing clearance will remove material from one part and can become embedded in one of the parts. Once embedded in one part it will abrade the other part until contact is no longer being made between the two parts. If the damage sufficiently degrades the oil film, the two parts will come into contact resulting in early wear-out or failure from lack of effective lubrication.

Abrasive particles can fly about during cleaning it is **very** important to block these particles from entering the engine as much as possible. This is particularly true of lubricating oil ports and oil drilling holes, especially those located downstream of the lubricating oil filters. Plug the holes instead of trying to blow the abrasive particles and debris with compressed air because the debris is often simply blown further into the oil drilling.

All old gasket material **must** be removed from the parts gasket surfaces. However, it is **not** necessary to clean and polish the gasket surface until the machining marks are erased. Excessive sanding or buffing can damage the gasket surface. Many newer gaskets are of the edge molded type (a steel carrier with a sealing member bonded to the steel). What little sealing material that can adhere is best removed with a blunt-edged scraper or putty knife. Cleaning gasket surfaces where an edge-molded gasket is used with abrasive pads or paper is usually a waste of time.

▲ WARNING ▲

Excessive sanding or grinding the carbon ring from the top of the cylinder liners can damage the liner beyond reuse. The surface finish will be damaged and abrasive particles can be forced into the liner material which can cause early cylinder wear-out or piston ring failures.

Tape off or plug all openings to any component interior before using abrasive pads or wire brushes. If really necessary because of time to use a power tool with abrasive pads, tape the oil drillings closed or use plug and clean as much of the surface as possible with the tool but clean around the oil hole/opening by hand so as to prevent contamination of the drilling. Then remove the tape or plug and clean the remaining area carefully and without the tool. **DO NOT** use compressed air to blow the debris out of oil drilling on an assembled engine! More likely than **not**, the debris can be blown further into the drilling. Using compressed air is fine if both ends of the drilling are open but that is rarely the case when dealing with an assembled engine.

Gasket Surfaces

The object of cleaning gasket surfaces is to remove any gasket material, not refinish the gasket surface of the part.

Cummins Inc. does **not** recommend any specific brand of liquid gasket remover. If a liquid gasket remover is used, check the directions to make sure the material being cleaned will **not** be harmed.

Air powered gasket scrapers can save time but care must be taken to **not** damage the surface. The angled part of the scraper must be against the gasket surface to prevent the blade from digging into the surface. Using air powered gasket scrapers on parts made of soft materials takes skill and care to prevent damage.

Do **not** scrape or brush across the gasket surface if at all possible.

Solvent and Acid Cleaning

Several solvent and acid-type cleaners can be used to clean the disassembled engine parts (other than pistons. See Below). Experience has shown that the best results can be obtained using a cleaner that can be heated to 90° to 95° Celsius (180° to 200° Fahrenheit). Kerosene emulsion based cleaners have different temperature specifications, see below. A cleaning tank that provides a constant mixing and filtering of the cleaning solution will give the best results. Cummins Inc. does not recommend any specific cleaners. Always follow the cleaner manufacturer's instructions. Remove all the gasket material, o-rings, and the deposits of sludge, carbon, etc., with a wire brush or scraper before putting the parts in a cleaning tank. Be careful not to damage any gasket surfaces. When possible, steam clean the parts before putting them in the cleaning tank.

▲ WARNING ▲

When using solvents, acids, or alkaline materials for cleaning, follow the manufacturers recommendations for use. Wear goggles and protective clothing to reduce the possibility of personal injury.

Experience has shown that kerosene emulsion based cleaners perform the best to clean pistons. These cleaners should **not** be heated to temperature in excess of 77°C (170°F). The solution begins to break down at temperatures in excess of 82°C (180°F) and will be less effective.

Do **not** use solutions composed mainly of chlorinated hydrocarbons with cresols, phenols and/or cresylic components. They often do **not** do a good job of removing deposits from the ring groove and are costly to dispose of properly.

Solutions with a pH above approximately 9.5 will cause aluminum to turn black; therefore do **not** use high alkaline solutions.

Chemicals with a pH above 7.0 are considered alkaline and those below 7.0 are acidic. As you move further away from the neutral 7.0, the chemicals become highly alkaline or highly acidic.

Remove all the gasket material, o-rings, and the deposits of sludge, carbon, etc., with a wire brush or scraper before putting the parts in a cleaning tank. Be careful to **not** damage any gasket surfaces. When possible use hot high pressure water or steam clean the parts before putting them in the cleaning tank. Removing the heaviest dirt before placing in the tank will allow the cleaner to work more effectively and the cleaning agent will last longer.

Rinse all the parts in hot water after cleaning. Dry completely with compressed air. Blow the rinse water from all the capscrew holes and the oil drillings.

If the parts are **not** to be used immediately after cleaning, dip them in a suitable rust proofing compound. The rust proofing compound **must** be removed from the parts before assembly or installation on the engine.

Steam Cleaning

Steam cleaning can be used to remove all types of dirt that can contaminate the cleaning tank. It is a good method for cleaning the oil drillings and coolant passages.

▲WARNING▲

When using a steam cleaner, wear safety glasses or a face shield, as well as protective clothing. Hot steam can cause serious personal injury.

Do **not** steam clean the following components:

- Electrical Components
- Wiring Harnesses
- Injectors
- Fuel Pump
- Belts and Hoses
- Bearings (ball or taper roller)
- Electronic Control Module (ECM)
- ECM Connectors

Plastic Bead Cleaning

Cummins Inc. does **not** recommend the use of glass bead blast or walnut shell media on **any** engine part. Cummins Inc. recommends using **only** plastic bead media, Part Number 3822735 or equivalent on any engine part. **Never** use sand as a blast media to clean engine parts. Glass and walnut shell media when **not** used to the media manufacturer's recommendations can cause excess dust and can embed in engine parts that can result in premature failure of components through abrasive wear.

Plastic bead cleaning can be used on many engine components to remove carbon deposits. The cleaning process is controlled by the use of plastic beads, the operating pressure and cleaning time.

▲CAUTION▲

Do not use bead blasting cleaning methods on aluminum pistons skirts or the pin bores in any piston, piston skirt or piston crown. Small particles of the media will embed in the aluminum or other soft metal and result in premature wear of the cylinder liner, piston rings, pins and pin bores. Valves, turbocharger shafts, etc., can also be damaged. Follow the cleaning directions listed in the procedures.

▲CAUTION▲

Do not contaminate wash tanks and tank type solvent cleaners with the foreign material and plastic beads. Remove the foreign material and plastic beads with compressed air, hot high pressure water or steam before placing them in tanks or cleaners. The foreign material and plastic beads can contaminate the tank and any other engine parts cleaned in the tank. Contaminated parts may cause failures from abrasive wear.

Plastic bead blasting media, Part Number 3822735, can be used to clean all piston ring grooves. Do **not** use any bead blasting media on piston pin bores or aluminum skirts.

Follow the equipment manufacturer's cleaning instructions. Make sure to adjust the air pressure in the blasting machine to the bead manufacturer's recommendations. Turning up the pressure can move material on the part and cause the plastic bead media to wear out more quickly. The following guidelines can be used to adapt to manufacturer's instructions:

1. Bead size: U.S. size Number 16 — 20 for piston cleaning with plastic bead media, Part Number 3822735
2. Operating Pressure — 270 kPa (40 psd) for piston cleaning. Pressure should not cause beads to break.

3. Steam clean or wash the parts with solvent to remove all of the foreign material and plastic beads after cleaning. Rinse with hot water. Dry with compressed air.

△CAUTION△

The bead blasting operation must not disturb the metal surface. If the metal surface is disturbed the engine can be damaged due to increased parts clearance or inadequate surface finish on parts that move against other parts.

When cleaning pistons, it is **not** necessary to remove all the dark stain from the piston. All that is necessary is to remove the carbon on the rim and in the ring grooves. This is best done by directing the blast across the part as opposed to straight at the part. If the machining marks are disturbed by the blasting process, then the pressure is too high or the blast is being held on one spot too long. The blast operation **must not** disturb the metal surface.

Walnut shell bead blast material is sometimes used to clean ferrous metals (iron and steel). Walnut shell blasting produces a great amount of dust particularly when the pressure if the air pressure on the blasting machine is increased above media manufacturer's recommendation. Cummins Inc. recommends **not** using walnut shell media to clean engine parts due to the risk media embedment and subsequent contamination of the engine.

Cummins Inc. now recommends glass bead media **NOT** used to clean any engine parts. Glass media is too easily embedded into the material particularly in soft materials and when air pressures greater than media manufacturer's recommend are used. The glass is an abrasive so when it is in a moving part, that part is abrading all the parts in contact with it. When higher pressures are used the media is broken and forms a dust of a very small size that floats easily in the air. This dust is very hard to control in the shop, particularly if **only** compressed air (and not hot water) is used to blow the media after it is removed from the blasting cabinet (blowing the part off inside the cabinet may remove large accumulations but never removes all the media).

Bead blasting is best used on stubborn dirt/carbon build-up that has **not** been removed by first steam/higher pressure washing then washing in a heated wash tank. This is particularly true of pistons. Steam and soak the pistons first then use the plastic bead method to safely remove the carbon remaining in the grooves (instead of running the risk of damaging the surface finish of the groove with a wire wheel or end of a broken piston ring. Make sure the parts are dry and oil free before bead blasting to prevent clogging the return on the blasting machine.

Always direct the bead blaster nozzle "across" rather than directly at the part. This allows the bead to get under the unwanted material. Keep the nozzle moving rather than hold on one place. Keeping the nozzle directed at one-place too long causes the metal to heat up and be moved around. Remember that the spray is **not** just hitting the dirt or carbon. If the machining marks on the piston groove or rim have been disturbed then there has **not** been enough movement of the nozzle and/or the air pressure is too high.

Never bead blast valve stems. Tape or use a sleeve to protect the stems during bead blasting. Direct the nozzle across the seat surface and radius rather than straight at them. The object is to remove any carbon build up and continuing to blast to remove the stain is a waste of time.

Acronyms and Abbreviations

General Information

The following list contains some of the acronyms and abbreviations used in this manual.

API	American Petroleum Institute
ASTM	American Society of Testing and Materials
°C	Celsius
CARB	California Air Resources Board
C.I.D.	Cubic Inch Displacement
CNG	Compressed Natural Gas
CPL	Control Parts List
cSt	Centistokes
ECM	Electronic Control Module
EGR	Exhaust Gas Recirculation
EPA	Environmental Protection Agency
°F	Fahrenheit
FMI	Failure Mode Identifier
GVW	Gross Vehicle Weight
LPG	Liquefied Petroleum Gas
Hg	Mercury
hp	Horsepower
H₂O	Water
ICM	Ignition Control Module
km/l	Kilometers per Liter
kPa	Kilopascal
LNG	Liquid Natural Gas
LTA	Low Temperature Aftercooling
MPa	Megapascal
mph	Miles Per Hour
mpq	Miles Per Quart
N•m	Newton-meter
NG	Natural Gas
OEM	Original Equipment Manufacturer
PID	Parameter Identification Descriptions
ppm	Parts Per Million
psi	Pounds Per Square Inch
PTO	Power Takeoff
rpm	Revolutions Per Minute
SAE	Society of Automotive Engineers
SCA	Supplemental Coolant Additive
STC	Step Timing Control
SID	Subsystem Identification Descriptions
VS	Variable Speed
VSS	Vehicle Speed Sensor

Section E - Engine and System Identification

Section Contents

	Page
Engine Diagrams	E-2
Engine Views.....	E-2
Engine Identification	E-1
Cummins Engine Nomenclature.....	E-1
Engine Dataplate.....	E-1

This Page Left Intentionally Blank

Engine Identification Engine Dataplate

The engine dataplates show specific information about the engine. The engine serial number (ESN) (1), Control Parts List (CPL) (2), model (3), and horsepower and rpm ratings (4) provide information for ordering parts and service needs.

NOTE: The engine dataplate **must not** be changed unless approved by Cummins Inc.

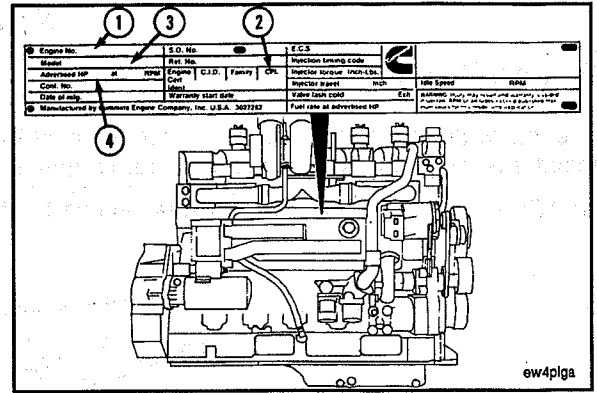

Cummins Engine Nomenclature

The model name provides identification data for the engine.

Refer to the illustration for the model name identification.

The application codes are:

- A = Agricultural
- C = Construction
- D = Generator Drive
- F = Fire Pump
- G = Gas
- L = Locomotive
- M = Marine
- P = Power Unit
- R = Railcar
- T = Tactical Military.

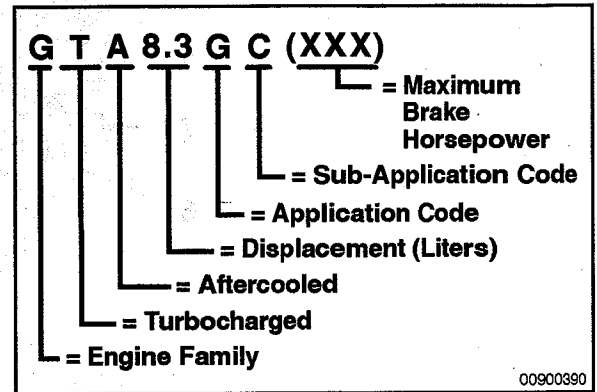

00900390

Engine Diagrams

Engine Views

The following illustrations show the locations of the major external engine components, filters, and other service and maintenance points. Some external components will be at different locations for different engine models.

NOTE: The illustrations are **only** a reference to show a typical engine.

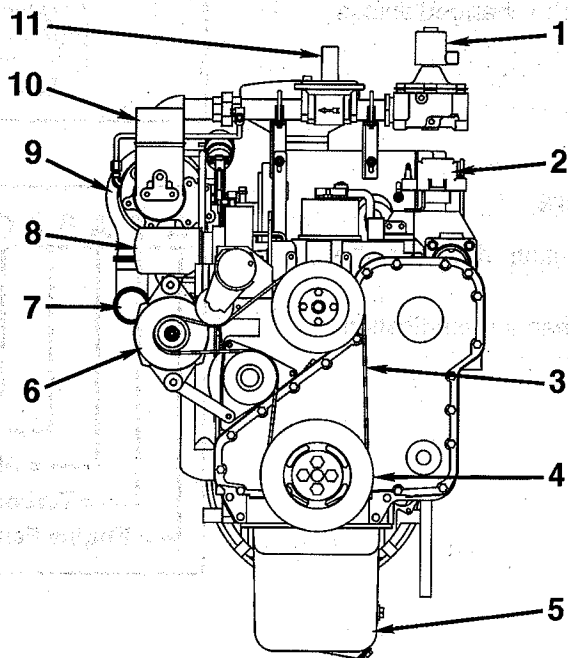

G8.3 Front View

1. Fuel shut off valve
2. Ignition coil
3. Drive Belt
4. Vibration damper
5. Oil pan
6. Alternator
7. Turbocharger compressor outlet (CAC only)
8. Coolant filter
9. Turbocharger
10. Turbocharger exhaust outlet
11. Secondary fuel regulator.

00900395

Engine Diagrams

Engine Views

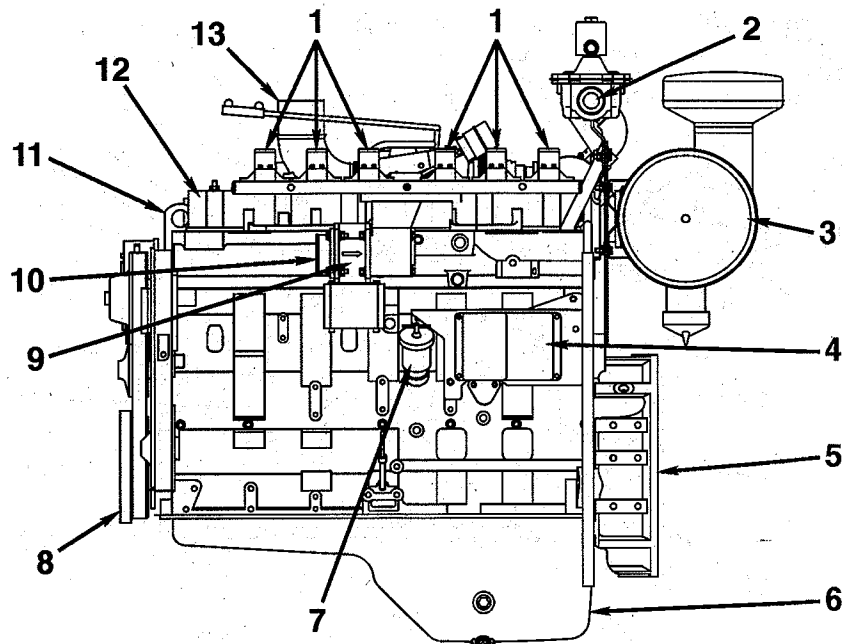

G8.3 Left/Aftercooler Side

00900396

1. Ignition coils
2. Fuel shutoff valve
3. Air cleaner housing
4. Ignition module
5. Flywheel housing
6. Oil pan
7. Dipstick
8. Vibration damper
9. Throttle body
10. Intake manifold inlet
11. Engine lift hook
12. Rocker lever covers
13. Exhaust outlet.

Engine Diagrams

Engine Views

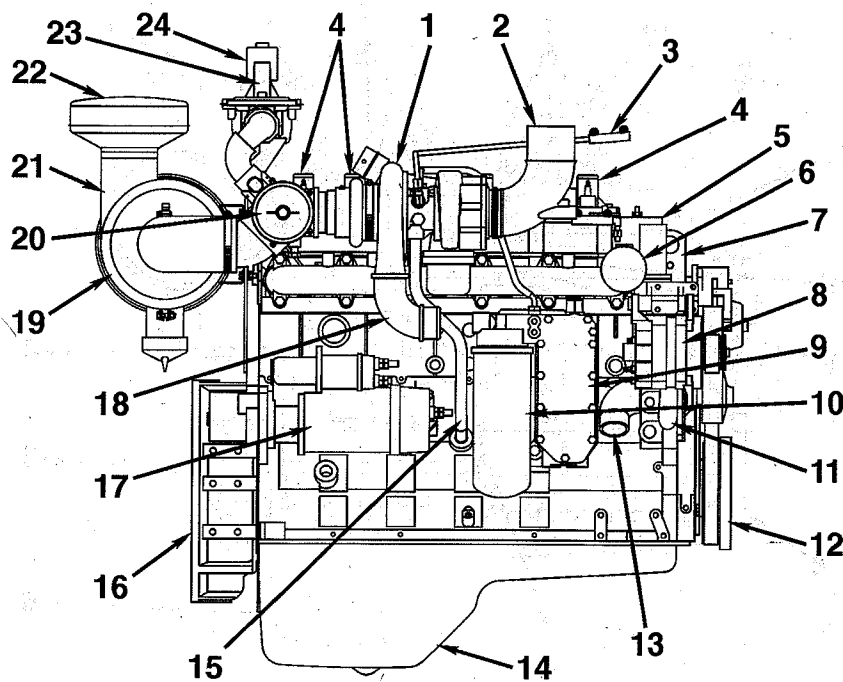

G8.3 Exhaust Side

00900397

1. Turbocharger
2. Turbocharger exhaust outlet
3. Governor linkage arm
4. Ignition coil
5. Rocker lever cover
6. Coolant filter
7. Engine lift hook
8. Alternator
9. Oil cooler
10. Oil filter
11. Water pump
12. Vibration damper
13. Coolant inlet
14. Oil pan
15. Turbocharger drain tube
16. Flywheel housing
17. Starter motor
18. Turbocharger compressor outlet (CAC only)
19. Air filter assembly
20. Air/fuel mixer
21. Air filter housing
22. Air filter inlet
23. Secondary fuel regulator
24. Fuel shutoff valve.

Engine Diagrams

Engine Views

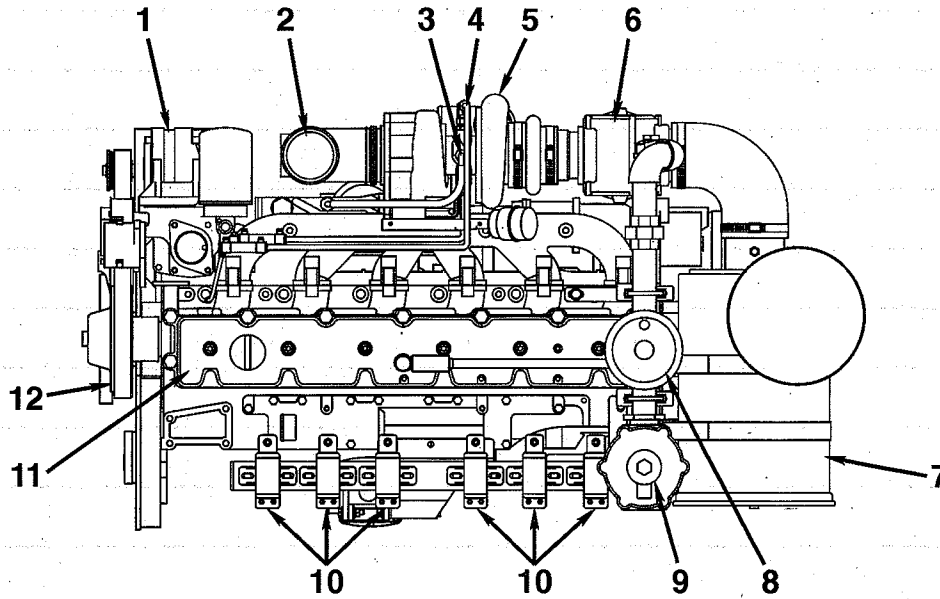

00900398

G8.3 Top View

1. Alternator
2. Turbocharger exhaust outlet
3. Turbocharger water supply
4. Turbocharger oil supply
5. Turbocharger
6. Air/fuel mixer
7. Air filter assembly
8. Secondary fuel regulator
9. Fuel shutoff valve
10. Ignition coils
11. Rocker lever cover
12. Vibration damper.

Section 1 - Operating Instructions

Section Contents

	Page
Cold Weather Starting	1-2
Using Starting Aids.....	1-2
Engine Operating Range	1-6
General Information.....	1-6
Engine Shutdown	1-6
General Information.....	1-6
Normal Starting Procedure	1-2
General Information.....	1-2
Operating Instructions - Overview	1-1
General Information.....	1-1
Operating the Engine	1-4
Ambient Temperature.....	1-5
0 to -32°C [32 to -25°F].....	1-5
-32 to -54°C [-25 to -65°F].....	1-5
Cold Weather.....	1-5
Normal.....	1-4
Winterfronts and Shutters.....	1-6
Starting Procedure After Extended Shutdown or Oil Change	1-3
General Information.....	1-3

This Page Left Intentionally Blank

Operating Instructions - Overview

General Information

Correct care of your engine will result in longer life, better performance, and more economical operation.

Follow the daily maintenance checks listed in Maintenance Guidelines (Section 2).

The new Cummins engine associated with this manual does not require a "break-in" procedure. This section of the manual provides all of the necessary information required for proper engine operation.

Check the oil pressure indicators, temperature indicators, warning lights, and other gauges daily to make sure they are operational.

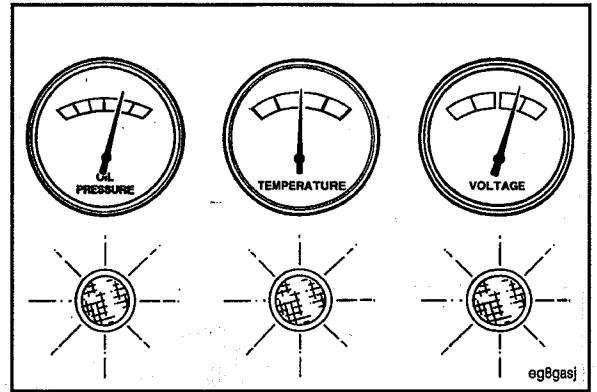

⚠ CAUTION ⚠

Do not expose the engine to corrosive chemicals. Corrosive chemicals can damage the engine.

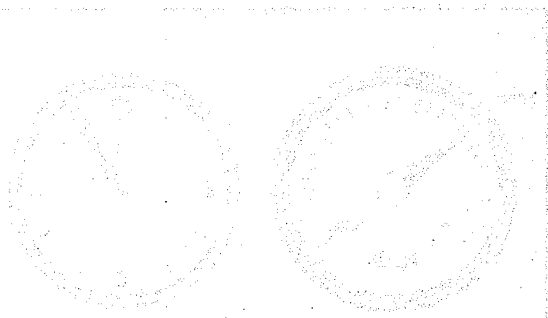
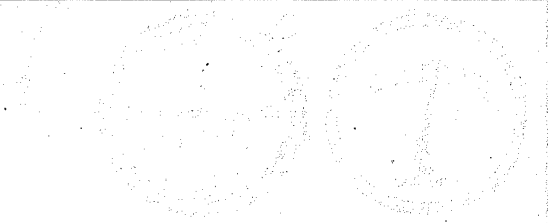

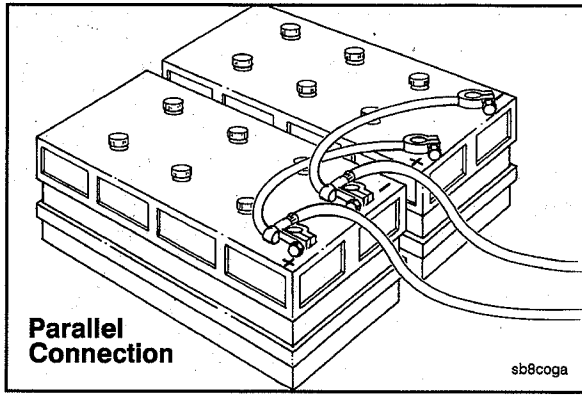

Normal Starting Procedure

General Information

⚠ CAUTION ⚠

To prevent damage to the starting motor, do not engage the starting motor for more than 30 seconds. Wait two minutes between each attempt to start (electrical starting motors only).

⚠ CAUTION ⚠

When using jumper cables to start the engine, make sure to connect the cables in parallel: positive (+) to positive (+) and negative (-) to negative (-). When using an external electrical source to start the engine, turn the disconnect switch to the "OFF" position. Remove the key before attaching the jumper cables to prevent unintentional starter engagement.

1. Check for free throttle operation.
2. Disengage the driven unit, or if equipped, put the transmission in neutral.
3. Position the fuel shutoff, electrical switch, or mechanism control to the RUN position.

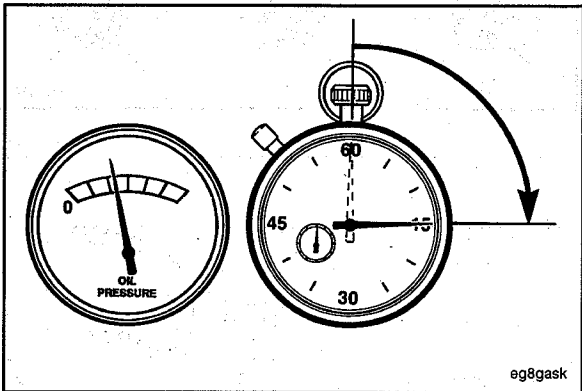

If the engine does **not** start after three attempts, check the fuel supply system.

Engine oil pressure **must** be indicated on the gauge within 15 seconds after starting. If oil pressure has **not** registered within 15 seconds, shut off the engine immediately to avoid engine damage. Check the engine oil level.

When starting a cold engine, increase the engine speed (rpm) slowly to make sure adequate lubrication is available to the bearings.

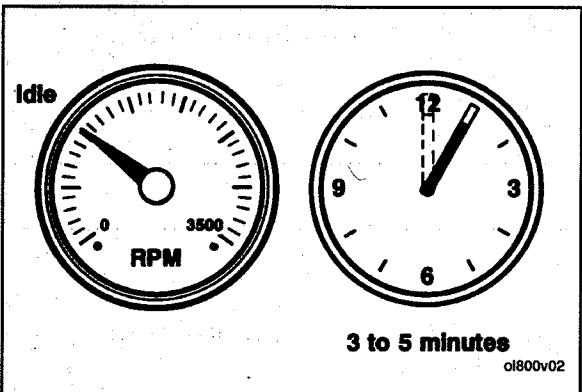

Cold Weather Starting

Using Starting Aids

⚠ CAUTION ⚠

In extreme temperatures, below -12°C [10°F], the only starting aids recommended for use are the coolant pre-heating system, and the oil pre-lube system. These systems are designed to keep the coolant and oil temperatures close to normal operating temperatures while the engine is not in operation.

⚠ CAUTION ⚠

Do not operate the engine unloaded for long periods. Periods of running unloaded for longer than 30 minutes can damage the engine. Increased oil consumption will result.

Follow the Normal Starting Procedures in this section.

Operate the engine 3 to 5 minutes at rated rpm before operating with a load.

Starting Procedure After Extended Shutdown or Oil Change

General Information

Complete the following steps after each oil change, or after the engine has been shut off for more than five days, to be sure that the engine receives oil flow through the lubrication system.

Verify that all sensors are functioning properly prior to engine start. Reset control and clear any inactive faults (using an electronic service tool).

Disconnect the engine position sensor if no pre-lubricating oil pump is installed.

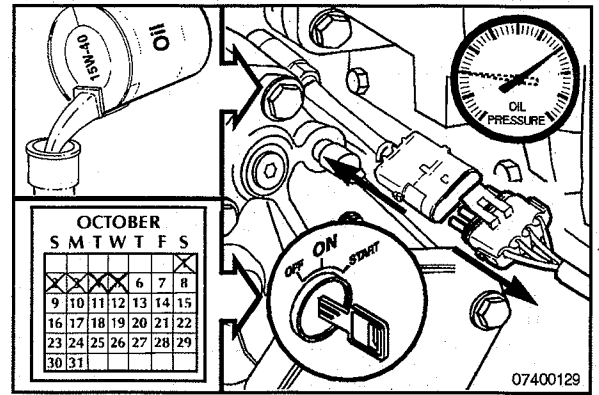

⚠ WARNING ⚠

Natural gas is highly flammable. Keep all cigarettes, sparks, arching switches and equipment, pilot lights, flames and other sources of ignition out of the work area, and areas sharing ventilation.

⚠ CAUTION ⚠

To reduce the possibility of shock loading of components downstream of the supply valve, opening and closing of the gas supply valve must be done slowly.

Make sure the fuel supply is shut off by turning the supply valve off as shown.

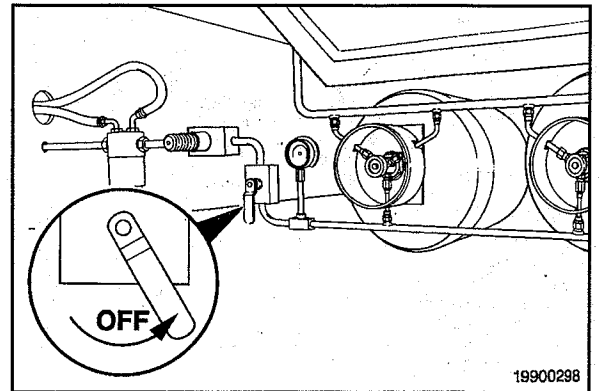

⚠ CAUTION ⚠

Do not engage the starter motor for more than 30 seconds. Wait two minutes between starter engagements to cool the starter motor.

Rotate the crankshaft using the starter motor until oil pressure appears on the gauge or the warning light goes out.

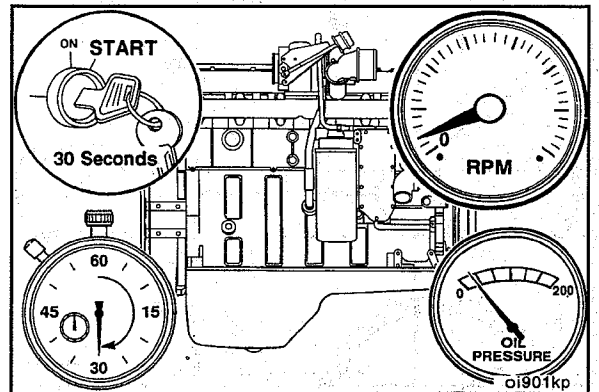

⚠ CAUTION ⚠

To reduce the possibility of shock loading of components downstream of the supply valve, opening and closing of the gas supply valve must be done slowly.

After oil pressure is observed, open the fuel supply valve.

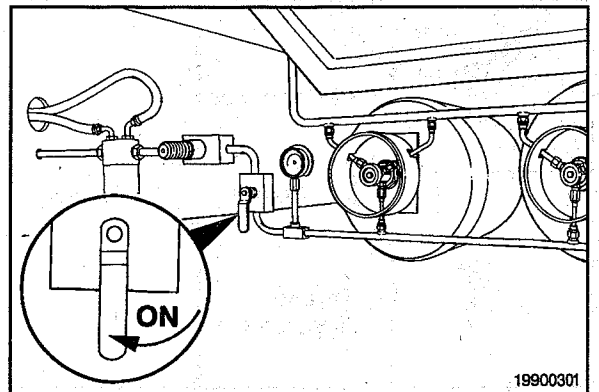

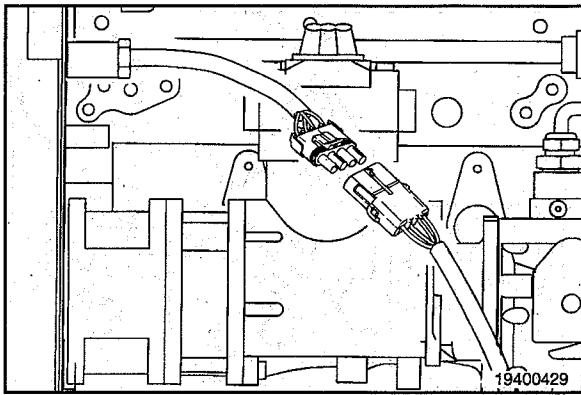

Connect the engine position sensor.

Start the engine. Refer to Procedure 101-014 (Normal Starting Procedures) in this section.

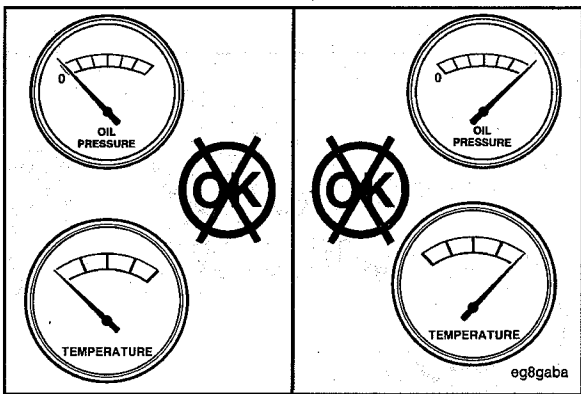

Operating the Engine Normal

If equipped, monitor the oil pressure and coolant temperature gauges frequently. Refer to Lubricating Oil System specifications and Cooling System specifications, in Maintenance Specifications (Section V) for recommended operating pressures and temperatures. Shut off the engine if any pressure or temperature does **not** meet the specifications.

Continuous operation with engine coolant temperature above or below the engine coolant temperature specifications listed in Maintenance Specifications (Section V) can damage the engine.

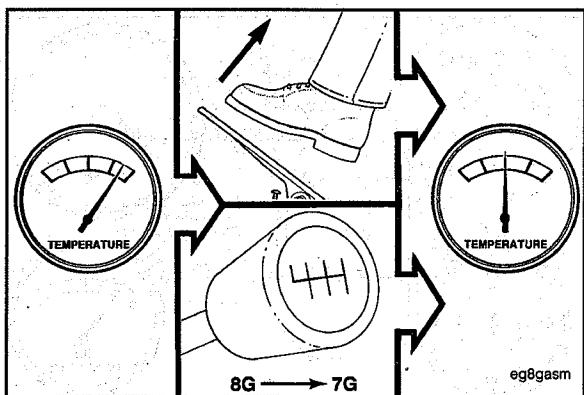

If an overheating condition starts to occur, reduce the power output of the engine by releasing the accelerator pedal or lever or shifting the transmission to a lower gear, or both, until the temperature returns to the normal operating range. If the engine temperature does **not** return to normal, shut off the engine, and refer to Troubleshooting Symptoms (Section TS), or contact a Cummins Authorized Repair Location.

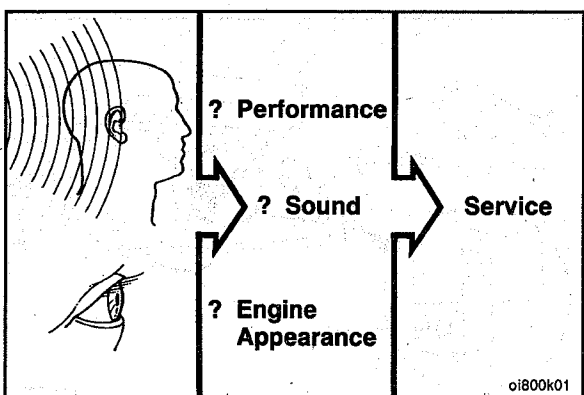

Most failures give an early warning. Look and listen for changes in performance, sound, or engine appearance that can indicate service or engine repair is needed. Some changes to look for are:

- Engine misfires
- Vibration
- Unusual engine noises
- Sudden changes in engine operating temperatures or pressures
- Excessive smoke
- Loss of power
- An increase in oil consumption
- An increase in fuel consumption
- Fuel, oil, or coolant leaks.

Cold Weather

It is possible to operate engines in extremely cold environments if they are properly prepared and maintained. Satisfactory performance of an engine in low ambient temperature conditions requires modification of the engine, surrounding equipment, operating practices and maintenance procedures.

The correct engine coolant lubricating oil and fuels **must** be used for the cold weather range in which the engine is being operated. Below are the recommendations for these critical engine fluids:

Ambient Temperature

0 to -32°C [32 to -25°F]

Use 50-percent ethylene glycol antifreeze and 50-percent water for the engine coolant mixture.

Refer to Maintenance Specifications (Section V) Lubricating Oil recommendations for the correct specifications.

-32 to -54°C [-25 to -65°F]

Use 60-percent ethylene glycol antifreeze and 40-percent water for the engine coolant mixture.

Refer to Maintenance Specifications (Section V) Lubricating Oil recommendations for the correct specifications.

The following cold weather operating aids are required for cold weather situations:

Cold Weather Operating Aids

Temperature	Coolant Heater	Oil Heater	Under-hood Air	Battery Heater	Radiator Shutters	Engine Enclosure	Thermatic Fan
50 to 32°F 10 to 0° C							Suggested
32 to -10°F 0 to -23° C	-12°C [11°F]	-12°C [11°F]	-9°C [15°F]	-9°C [15°F]	-0°C [32°F]	-19°C [-2°F]	-19°C [-2°F]
-10 to -25°F -23 to -32° C	Required	Required*	Required	Required	Required	Required	Required
-25 to -65°F -32 to -54° C							

* Required dependent upon viscosity/pour point.

00200040

Winterfronts and Shutters

Winterfronts and shutters can be used on a vehicle or equipment to reduce air flow through the radiator core into the engine compartment. This can reduce the time required to warm the engine and help maintain the engine coolant temperature. The engine coolant temperature specifications are in the Maintenance Specification (Section V).

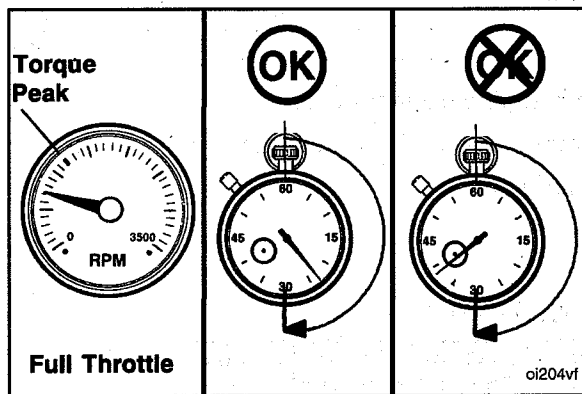

Engine Operating Range General Information

⚠ CAUTION ⚠

Do not operate the engine at full throttle operation below peak torque rpm (refer to engine dataplate for peak torque rpm) for more than 30 seconds. Operating the engine at full throttle below peak torque will shorten engine life to overhaul, can cause serious engine damage, and is considered engine abuse.

Cummins engines are designed to operate successfully at full throttle under transient conditions down to peak torque engine speed. This is consistent with recommended operating practices.

⚠ CAUTION ⚠

Do not operate the engine beyond the maximum engine speed. Operating the engine beyond the maximum engine speed can cause severe engine damage. Use proper operating techniques for the vehicle, vessel, or equipment to prevent engine overspeed. The maximum engine speed specification is listed in Maintenance Specifications (Section V).

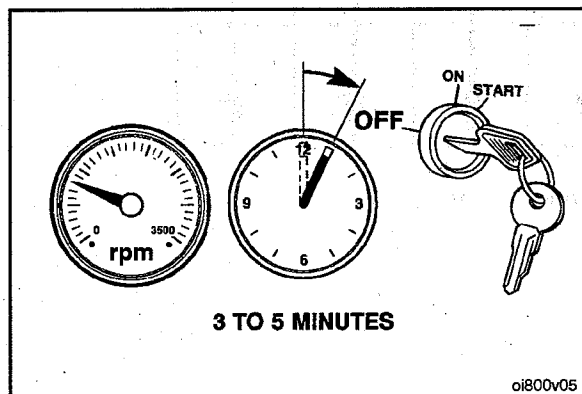

Engine Shutdown General Information

Allow the engine to idle 3 to 5 minutes before shutting it off after a full-load operation. This allows adequate cool down of pistons, cylinders, bearings, and turbocharger components.

Turn the ignition switch to the OFF position. If the engine does not shut down, refer to Troubleshooting Symptom (Section TS).

Section 2 - Maintenance Guidelines

Section Contents

	Page
Maintenance Guidelines - Overview	2-1
General Information.....	2-1
Maintenance Record Form	2-5
Maintenance Data.....	2-5
Maintenance Schedule	2-2
General Information.....	2-2
Industrial Applications.....	2-2
Power Generation.....	2-3
Gas Compression.....	2-4
Tool Requirements	2-1
General Information.....	2-1

availability of maintenance and repair
of engine and related

1. The engine shall be maintained in accordance with the manufacturer's recommendations.
2. The engine shall be inspected for leaks and abnormal noises at each service interval.
3. The engine shall be cleaned and protected from corrosion at each service interval.
4. The engine shall be tested for performance and efficiency at each service interval.
5. The engine shall be replaced if it is found to be inoperable or unsafe.

This Page Left Intentionally Blank

Maintenance Guidelines - Overview

General Information

Cummins Inc. recommends that the engine be maintained according to the Maintenance Schedule in this section.

If the engine is operating in ambient temperatures below -18°C [0°F] or above 38°C [100°F], perform maintenance at shorter intervals. Shorter maintenance intervals are also required if the engine is operated in a dusty environment or if frequent stops are made. Contact your local Cummins Authorized Repair Location for recommended maintenance intervals.

Some of these maintenance procedures require special tools or must be completed by qualified personnel. Contact your local Cummins Authorized Repair Location for detailed information.

If your engine is equipped with a component or accessory not manufactured by Cummins Inc., refer to the component manufacturer's maintenance recommendations.

Use the chart provided in this section as a convenient way to record maintenance performed.

Tool Requirements

General Information

Most of the maintenance operations described in this manual can be performed with common hand tools (metric and S.A.E. wrenches, sockets, and screwdrivers).

The following is a list of special service tools required for some maintenance operations:

Tool Part Number	Description
3375049	Oil Filter Wrench
3376592	Torque Wrench (valve adjustment)
3822524	Belt tension gauge, click type (v-belts and v-ribbed with 4 or 5 ribs)
3822525	Belt tension gauge, click type (v-ribbed with 6 to 12 ribs)
ST-1138	Belt tension gauge
3163099	In-line data link adapter kit
ST-1138	Belt tension gauge (v-ribbed belts 6 to 9 ribs)
3163196	Torque wrench adapter (used with 3163099 torque wrench)
ST-1273	Pressure gauge 0 to 1900 Hg [0 to 75 in Hg]
3824510	Electronic contact cleaner
3164486	Tester, Ignition (All natural gas and LPG engines)
3164204	Tester, Ignition (C8.3G and C Gas Plus only)
3376589	Female Compucheck® quick connect
3823983	Compression gauge/adapter set
3165179	Combustible gas detector
3824876	Plug socket
3164491	Pressure vacuum module
3164498	Automotive meter
3823921	Cylinder head capscrew length gauge
3163292	Valve spring compressor
3824510	QD contact cleaner: (to clean electrical connections)
3375273	Pressure kit, portable
3376891	Fluorescent dye
3163337	Battery black light
3824879	Anti-seize compound
ST-537	Dial depth gauge
ST-1111-3	Manometer
3164488	Digital multimeter

NOTE: Contact a Cummins Authorized Repair Location for information on hardware requirements.

Maintenance Schedule

General Information

Industrial Applications

All maintenance procedures listed for previous intervals **must** also be performed.

For convenience, listed below are the section numbers that contain specific instructions for performing the maintenance.

Daily - Maintenance Checks

Section 3

- Lubricating Oil Level - Check
- Engine Governor Oil Level - Check
- Engine Coolant Level - Check
- Aftercooler Coolant Level - Check
- Engine Crankcase Breather Tube - Check
- Fan, Cooling - Check
- Drive Belts - Check

Every 250 Hours, or 3 Months - Maintenance Checks

Section 4

- Lubricating Oil and Filters - Change
- Intake System Piping - Check
- Air Cleaner Restriction - Check
- Overhead Set¹ - Adjust
- Air/Fuel Mixer - O₂ Setting - Check

Every 750 Hours, or 6 Months - Maintenance Checks

Section 5

- Supplemental Coolant Additives (SCA) and Antifreeze² - Check
- Fan Belt Tensioner - Check
- Spark Plugs - Check

Every 1500 Hours, or 1 Year - Maintenance Checks

Section 6

- Engine Hoses - Check
- Engine Mounts - Check
- Batteries - Check
- Battery Cables and Connections - Check
- Auxiliary Water Pump - Check
- Spark Plug Wires - Check
- Engine Assembly - Clean
- Gas Filter - Replace
- Coolant Filter - Replace
- Overhead Set - Adjust
- Engine Timing - Check
- Gas Pressure to Air-Fuel Mixer - Check
- Air Cleaner - Replace
- Engine Governor Oil - Replace

Every 6000 Hours, or 2 Years - Maintenance Checks

Section 7

- Engine Water Pump - Check
- Water Pump Idler Assembly - Check
- Fan Hub - Check
- Vibration Damper - Check
- Turbocharger - Check
- Engine Coolant - Replace
- Drive Belt, Cooling Fan - Check

- Drive Belt , Aftercooler - Check
- 1. Adjust the valves at the first oil change period of 250 operating hours, and then at the interval of every 1500 hours or 1 year, whichever comes first.
- 2. Check the coolant additive concentration every 6 months unless the concentration is over 3.0 units. Then, check at every oil change interval until the concentration is below 3.0 units.

Power Generation

All maintenance procedures listed for previous intervals **must** also be performed.

For convenience, listed below are the section numbers that contain specific instructions for performing the maintenance.

Daily - Maintenance Checks

Section 3

- Lubricating Oil Level - Check
- Engine Governor Oil Level - Check
- Engine Coolant Level - Check
- Aftercooler Coolant Level - Check
- Engine Crankcase Breather Tube - Check
- Fan, Cooling - Check
- Drive Belts - Check

Every 250 Hours, or 1 Year - Maintenance Checks

Section 4

- Lubricating Oil and Filters - Change
- Intake System Piping - Check
- Air Cleaner Restriction - Check
- Overhead Set¹ - Adjust
- Air/Fuel Mixer - O₂ Setting - Check

Every 750 Hours, or 1 Year - Maintenance Checks

Section 5

- Supplemental Coolant Additives (SCA) and Antifreeze² - Check
- Fan Belt Tensioner - Check
- Spark Plugs- Check

Every 1500 Hours, or 1 Year - Maintenance Checks

Section 6

- Engine Hoses - Check
- Engine Mounts - Check
- Batteries - Check
- Battery Cables and Connections - Check
- Auxiliary Water Pump - Check
- Coolant Heater - Check
- Spark Plug Wires - Check
- Engine Assembly - Clean
- Gas Filter - Replace
- Coolant Filter - Replace
- Overhead Set - Adjust
- Engine Timing - Check
- Gas Pressure to Air-Fuel Mixer - Check
- Air Cleaner - Replace
- Engine Governor Oil - Replace

Every 6000 Hours, or 2 Years - Maintenance Checks

Section 7

- Engine Water Pump - Check
- Water Pump Idler Assembly - Check
- Fan Hub - Check
- Vibration Damper - Check
- Turbocharger - Check

- Engine Coolant - Replace
 - Drive Belt, Cooling Fan - Check
 - Drive Belt, Aftercooler - Check
1. Adjust the valves at the first oil change period of 250 operating hours, and then at the interval of every 1500 hours or 1 year, whichever comes first.
 2. Check the coolant additive concentration every 6 months unless the concentration is over 3.0 units. Then, check at every oil change interval until the concentration is below 3.0 units.

Gas Compression

All maintenance procedures listed for previous intervals **must** also be performed.

For convenience, listed below are the section numbers that contain specific instructions for performing the maintenance.

Daily - Maintenance Checks

Section 3

- Lubricating Oil Level - Check
- Engine Governor Oil Level - Check
- Engine Coolant Level - Check
- Aftercooler Coolant Level - Check
- Engine Crankcase Breather Tube - Check
- Fan, Cooling - Check
- Drive Belts - Check
- Air Cleaner Restriction - Check

Every 250 Hours, or 3 Months - Maintenance Checks

Section 4

- Lubricating Oil and Filters - Change
- Intake System Piping - Check
- Overhead Set¹ - Adjust
- Air/Fuel Mixer - O₂ Setting - Check

Every 750 Hours, or 6 Months - Maintenance Checks

Section 5

- Supplemental Coolant Additives (SCA) and Antifreeze² - Check
- Fan Belt Tensioner - Check
- Spark Plugs - Check

Every 1500 Hours, or 1 Year - Maintenance Checks

Section 6

- Engine Hoses - Check
- Engine Mounts - Check
- Batteries - Check
- Battery Cables and Connections - Check
- Auxiliary Water Pump - Check
- Coolant Heater - Check
- Spark Plug Wires - Check
- Engine Assembly - Clean
- Gas Filter - Replace
- Coolant Filter - Replace
- Overhead Set - Adjust
- Engine Timing - Check
- Gas Pressure to Air-Fuel Mixer - Check
- Air Cleaner - Replace
- Engine Governor Oil - Replace

Every 6000 Hours, or 2 Years - Maintenance Checks

Section 7

- Engine Water Pump - Check
- Water Pump Idler Assembly - Check
- Fan Hub - Check

Section 3 - Maintenance Procedures at Daily Interval

Section Contents

	Page
Coolant Level	3-2
Maintenance Check.....	3-2
Crankcase Breather Tube	3-5
Maintenance Check.....	3-5
Daily Maintenance Procedures - Overview	3-1
Engine Operation Report.....	3-1
General Information.....	3-1
Unusual Engine Noise.....	3-1
Drive Belts	3-3
Maintenance Check.....	3-3
Poly-Vee Belt.....	3-3
Cogged Belt.....	3-3
Fan, Cooling	3-4
Inspect for Reuse.....	3-4
Governor Oil	3-6
Maintenance Check.....	3-6
Lubricating Oil Level	3-5
Maintenance Check.....	3-5

This Page Left Intentionally Blank

Daily Maintenance Procedures - Overview

General Information

Preventative maintenance begins with day-to-day awareness of the engine and its system. Before starting the engine, check the oil and coolant levels. Look for:

- Leaks
- Loose or damaged parts
- Worn or damaged belts
- Any change in engine appearance.
- Odor of fuel

Engine Operation Report

The engine **must** be maintained in top mechanical condition if the operator is to get optimum satisfaction from its use. The maintenance department needs daily running reports from the operator to make necessary adjustments in the time allocated. The daily running report also helps to make provisions for more extensive maintenance work as the reports indicate the necessity.

Comparison and intelligent interpretation of the daily report, along with a practical follow-up action, will eliminate most failures and emergency repairs.

Report to the maintenance department any of the following conditions:

- Low lubricating oil pressure
- Low power
- Power increases or engine surge
- Erratic or no accelerator control or response
- Any warning lights flashing or staying on
- Abnormal water or oil temperature
- Unusual engine noise
- Excessive smoke
- Excessive use of coolant, fuel, or lubricating oil
- Any fuel, coolant, or lubricating oil leaks
- Loose or damaged parts
- Worn or damaged belts

Unusual Engine Noise

During daily maintenance checks, listen for any unusual engine noise that can indicate that service is required.

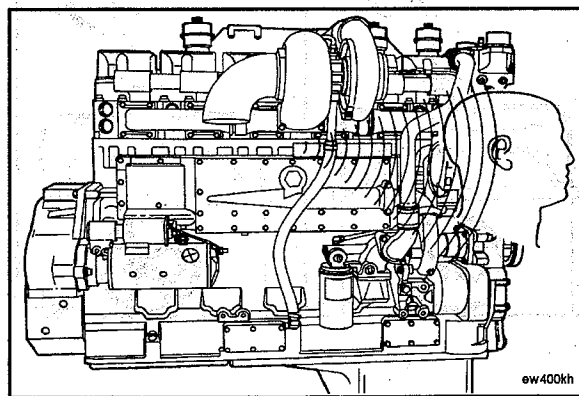

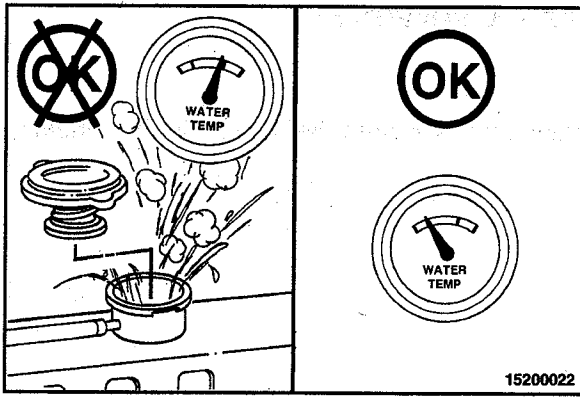

Coolant Level Maintenance Check

⚠ WARNING ⚠

Do not remove a pressure cap from a hot engine. Wait until the coolant temperature is below 50°C [120°F] before removing the pressure cap. Heated coolant spray or steam can cause personal injury.

⚠ CAUTION ⚠

Never use a sealing additive to stop leaks in the cooling system. This can result in cooling system plugging and inadequate coolant flow, causing the engine to overheat.

The coolant level must be checked daily.

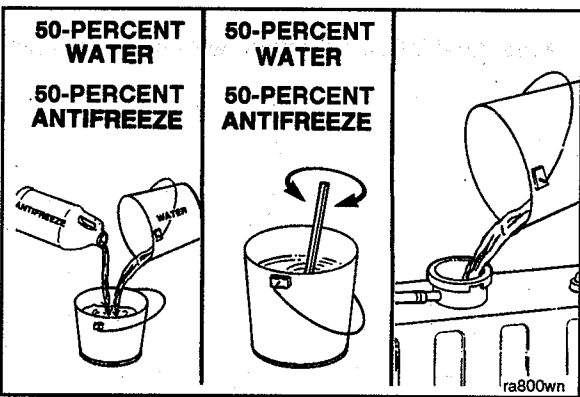

⚠ CAUTION ⚠

Do not add cold coolant to a hot engine. Engine castings can be damaged. Allow the engine to cool to below 50°C [120°F] before adding coolant.

Make up coolant added to the engine must be mixed with the correct proportions of antifreeze, supplemental coolant additive, and water to avoid engine damage.

Coolant recommendations and specification details on correct mixing of coolant can be found in Maintenance Specifications (Section V).

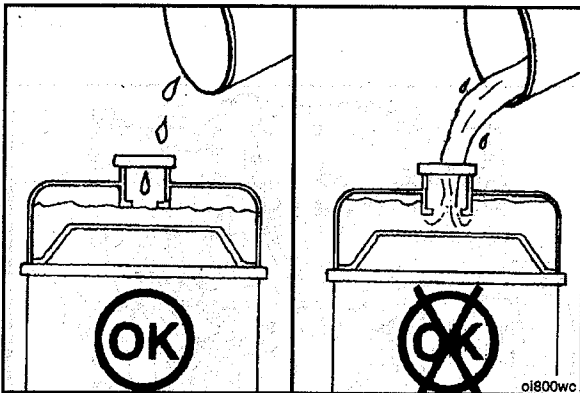

Fill the cooling system with coolant to the bottom of the fill neck in the radiator fill or expansion tank.

NOTE: Some radiators have two fill necks, both of which must be filled when the cooling system is drained.

Drive Belts

Maintenance Check

Poly-Vee Belt

Inspect the belts daily. Check the belt for intersecting cracks. Traverse (across the belt width) cracks are acceptable. Longitudinal (direction of belt length) cracks that intersect with transverse cracks are **not** acceptable. Replace the belt if it is frayed or has pieces of material missing. Refer to Section A for belt adjustment and replacement procedures.

Belt damage can be caused by:

- Incorrect tension
- Incorrect size or length
- Pulley misalignment
- Incorrect installation
- Severe operating environment
- Oil or grease on the side of belts.

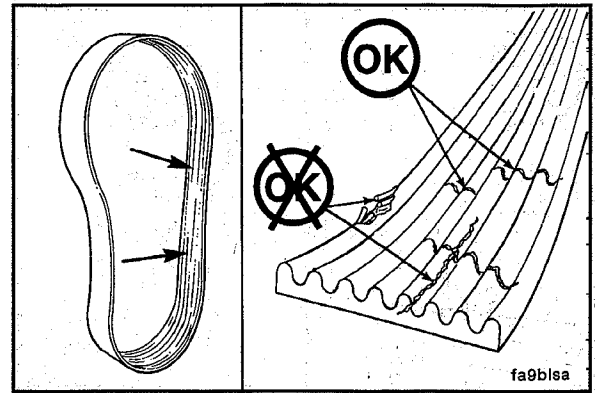

Cogged Belt

Inspect the belts daily. Replace the belts if they are cracked, frayed, or have chunks of material missing. Small cracks are acceptable.

Adjust the belts that have a glazed or shiny surface, which indicates belt slippage. Correctly installed and tensioned belts will show even pulley and belt wear. Refer to Section A for belt adjustment and replacement procedures.

Belt damage can be caused by:

- Incorrect tension
- Incorrect size or length
- Pulley misalignment
- Incorrect installation
- Severe operating environment
- Oil or grease on the belts

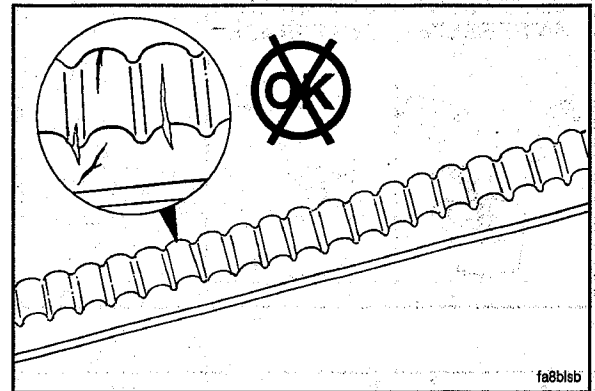

Measure the belt tension in the center span of the pulleys.

Refer to the Belt Tension Chart in Section V for the correct gauge and tension value for the belt width used.

An alternate method (deflection method) can be used to check belt tension by applying 110 N [25 lbf] force between the pulleys on v-belts. If the deflection is more than one belt thickness per foot of pulley center distance, the belt tension **must** be adjusted.

Refer to Section A for adjustment procedures.

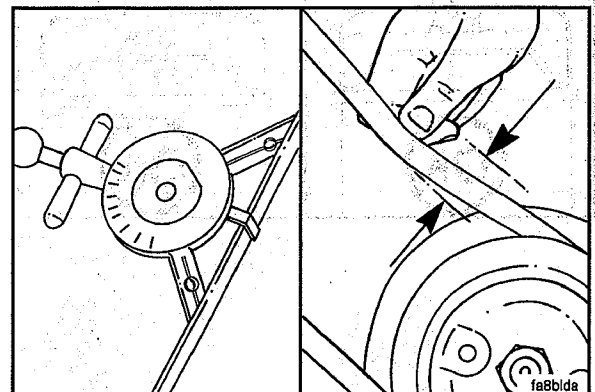

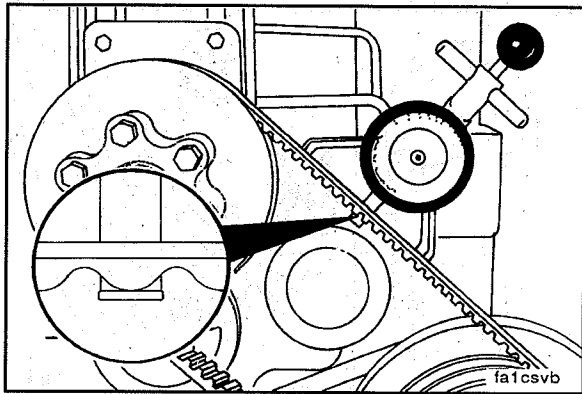

For cogged belts, **make sure** that the belt tension gauge is positioned so that the center tensioning leg is placed directly over the high point (hump) of a cog. Other positioning will result in incorrect measurement.

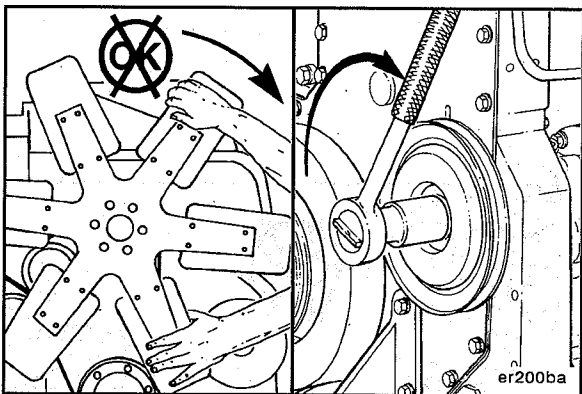

Fan, Cooling Inspect for Reuse

▲ WARNING ▲

Do not rotate the engine by pulling or prying on the fan. The fan blade(s) can be damaged and cause the fan to fail and cause personal injury or property damage. Use the accessory drive shaft or the crankshaft barring tool to rotate the crankshaft.

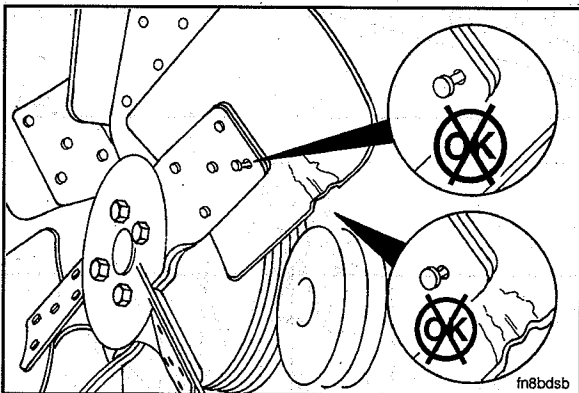

A visual inspection of the cooling fan is required daily. Check for cracks, loose rivets, and bent or loose blades. Check the fan to make sure it is securely mounted. Tighten the capscrews, if necessary.

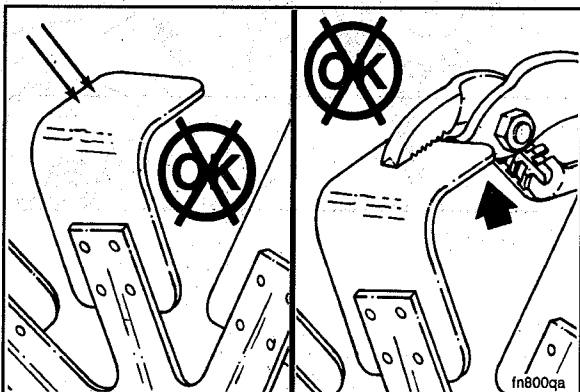

▲ WARNING ▲

Do not straighten a bent fan blade or continue to use a damaged fan. A bent or damaged fan blade can fail during operation and cause personal injury or property damage.

Replace original equipment fan that is damaged with a fan of the identical part number. Cummins Inc. **must** approve any other fan changes to be covered under warranty.

Refer to the vehicle or equipment manufacturer's specifications for capscrew torque.

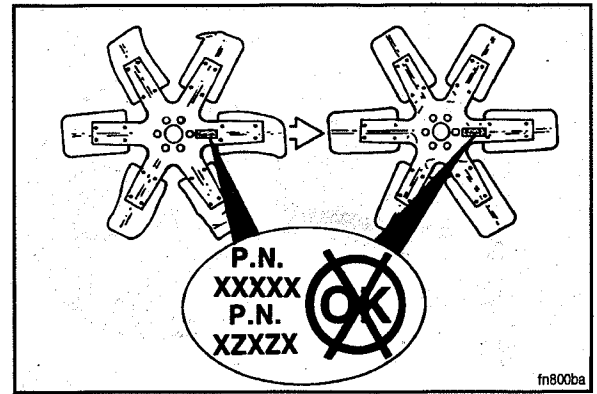

Lubricating Oil Level Maintenance Check

⚠CAUTION⚠

Never operate the engine with oil level below the L (low) mark or above the H (high) mark. Poor engine performance or engine damage can occur.

The engine **must** be level when checking the oil level to make sure the measurement is correct.

Shut off the engine for an accurate reading.

Wait at least 15 minutes after shutting off the engine to check the oil level. This allows time for the oil to drain into the oil pan.

For additional lubricating oil recommendations and oil pan capacity information, refer to Maintenance Specifications (Section V).

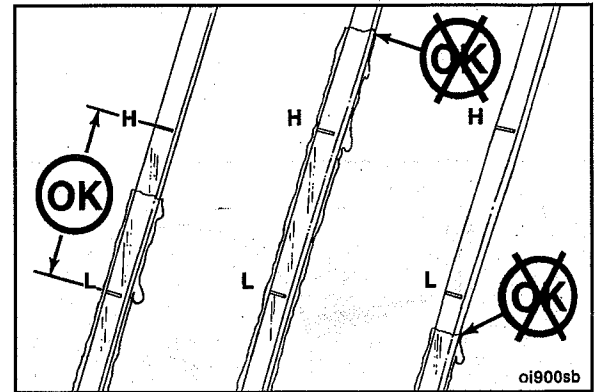

Crankcase Breather Tube Maintenance Check

Inspect the breather tube for sludge, debris, or ice in the tube.

Inspect the tube more frequently in icy conditions.

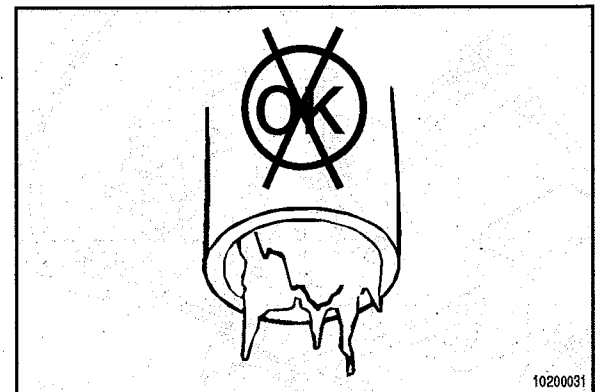

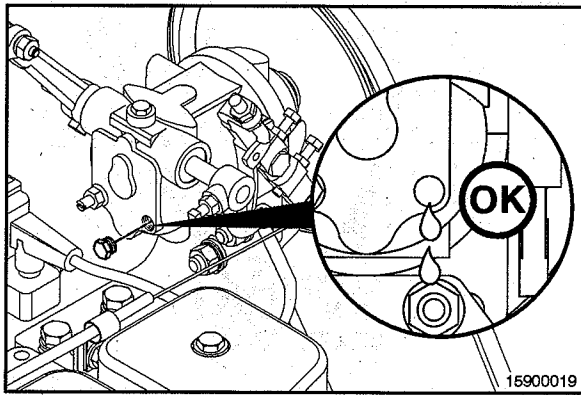

Governor Oil Maintenance Check



▲ WARNING ▲

The engine must shut down and be level when checking the governor oil level. If the engine is not shut down or level, an improper reading will result which can result in a governor malfunction and possible damage to the engine.

▲ WARNING ▲

To reduce the possibility of personal injury, avoid direct contact of hot oil with your skin.

Slowly remove the pipe plug from the base of the governor.

If the governor oil drips out of the drain plug opening, the governor oil level is correct.

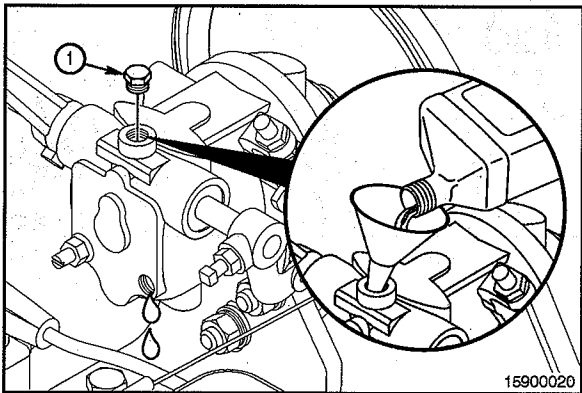

If no oil drips out of the drain plug opening, remove the pipe plug (1) and slowly add oil to the governor until oil is coming out of the drain plug opening.

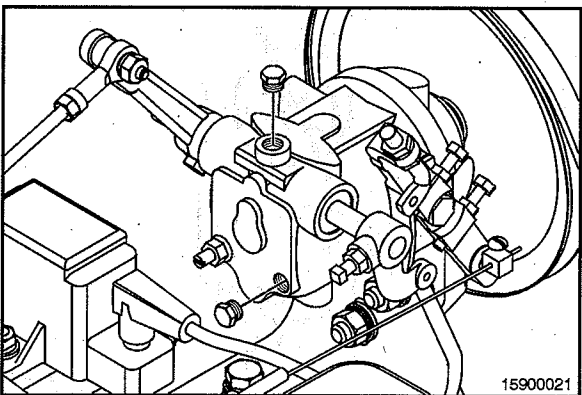

Install the drain plug, fill pipe plug and tighten.



Torque Value:

Pipe and Drain 25 N•m [18 ft-lb]

Plugs

Section 4 - Maintenance Procedures at 250 Hours or 3 Months

Section Contents

	Page
Air Cleaner Restriction	4-1
Maintenance Check.....	4-1
Charge-Air Piping	4-2
Maintenance Check.....	4-2
Lubricating Oil and Filters	4-7
Drain.....	4-7
Fill.....	4-9
General Information.....	4-7
Install.....	4-8
Remove.....	4-8
Maintenance Procedures - Overview	4-1
General Information.....	4-1
Overhead Set	4-4
Adjust.....	4-5
Finishing Steps.....	4-6
Preparatory Steps.....	4-4
Rocker Lever Cover	4-2
Clean and Inspect for Reuse.....	4-2
Finishing Steps.....	4-4
Install.....	4-3
Preparatory Steps.....	4-2
Remove.....	4-2

This Page Left Intentionally Blank

Maintenance Procedures - Overview

General Information

All maintenance checks and inspections listed in previous maintenance intervals **must** also be performed at this time, in addition to those listed under this maintenance interval.

Air Cleaner Restriction

Maintenance Check

Mechanical Indicator

NOTE: Do **not** remove the felt washer from the indicator. The felt washer absorbs moisture.

A mechanical restriction indicator is available to indicate excessive air restriction through a dry-type air cleaner. This instrument can be mounted in the air cleaner outlet or on the instrument panel. The red flag (1) in the window gradually rises as the cartridge loads with dirt. After changing or replacing the cartridge, reset the indicator by pushing the reset button (2).

Restriction or vacuum indicators need to be installed as close as possible to the turbocharger air inlet in order to obtain a true indication of restrictions.

⚠CAUTION⚠

Never operate the engine without an air cleaner. Intake air must be filtered to prevent dirt and debris from entering the engine and causing premature wear.

Vacuum Indicator

Vacuum switches actuate a warning light on the instrument panel when the air restriction becomes excessive.

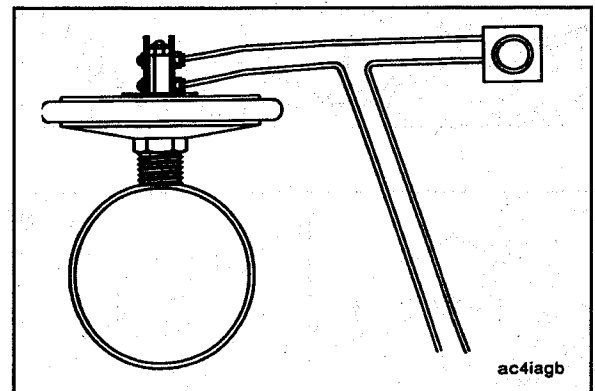
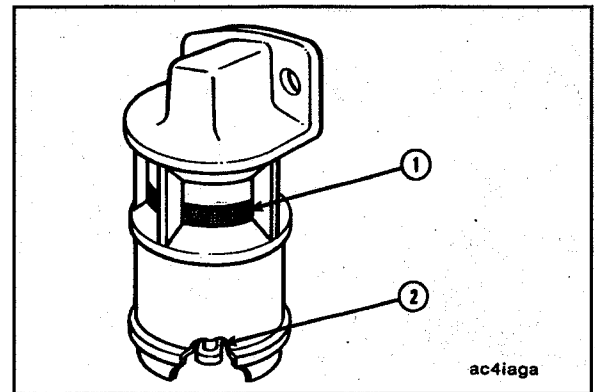

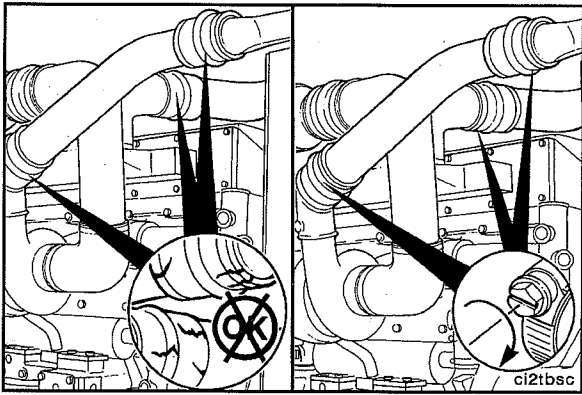

Charge-Air Piping Maintenance Check



Inspect the charge-air piping and hoses for leaks, holes, cracks, or loose connections. Tighten the hose clamps if necessary. Refer to the vehicle or equipment manufacturer's specifications for the correct torque value.

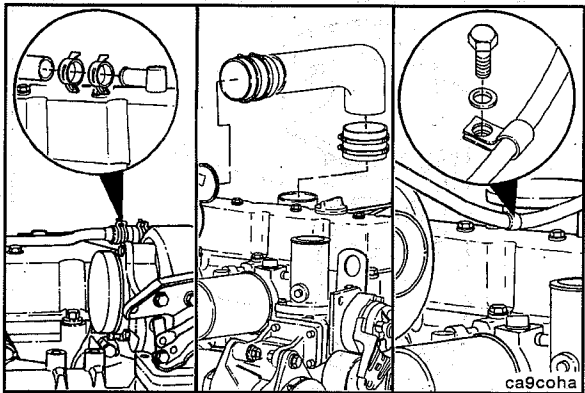

Rocker Lever Cover Preparatory Steps

NOTE: Shown throughout this procedure is the C8.3 diesel engine. Although different the procedure remains the same.

Remove the crankcase breather tube and hose.

Remove the air crossover tube (if installed).

Remove the capscrew from the support bracket for the turbocharger wastegate actuator hose (if installed).

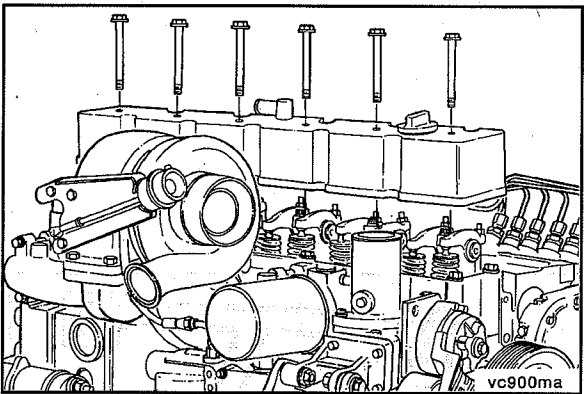

Remove

Remove the six valve cover mounting capscrews.

Discard the sealing o-rings.

Remove the Rocker Lever Cover.

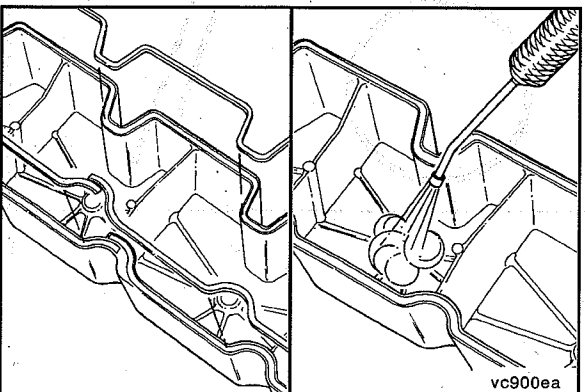

Clean and Inspect for Reuse



WARNING



When using a steam cleaner, wear protective clothing and safety glasses or a face shield. Hot steam can cause serious personal injury.



Inspect the seal for damage.

NOTE: The gasket can be reused if it is **not** damaged.

Steam-clean and dry with compressed air.

Inspect the cover for cracks or damage and replace if necessary.

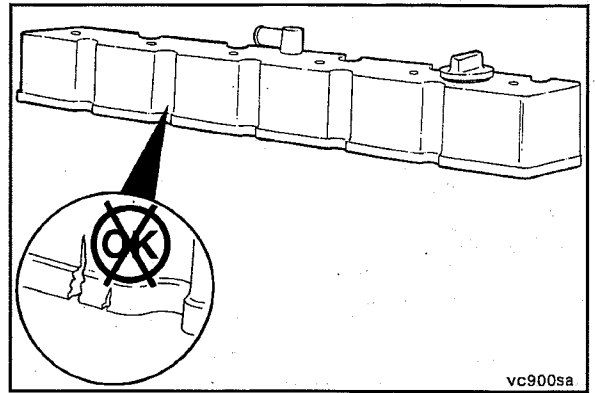

Install

NOTE: If the rocker lever gasket is **not** damaged, it can be reused.

If the rocker lever gasket is damaged, install a new gasket.

Install the rocker lever gasket into the groove in the rocker lever cover. Start the installation at the overlap area shown in the illustration. Do **not** stretch the rubber rocker lever gasket.

If the rocker lever gasket has more overlap than shown in the illustration, trim the length to provide the correct overlap.

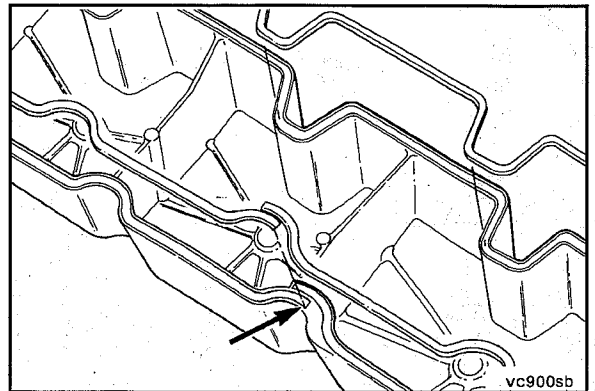

Install new sealing o-rings on the capscrews.

Install the six capscrews into the cover.

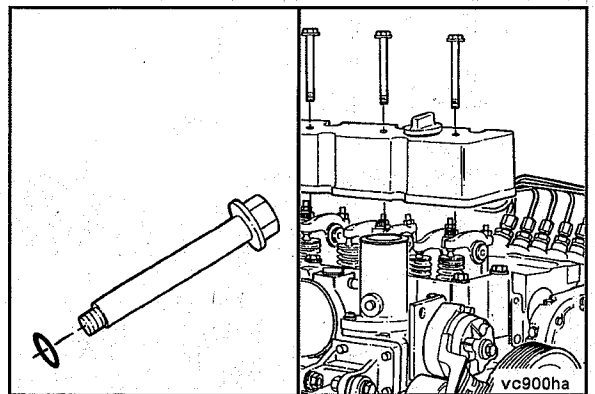

Tighten the capscrews in the sequence shown.

Torque Value: 24 N•m [18 ft-lb]

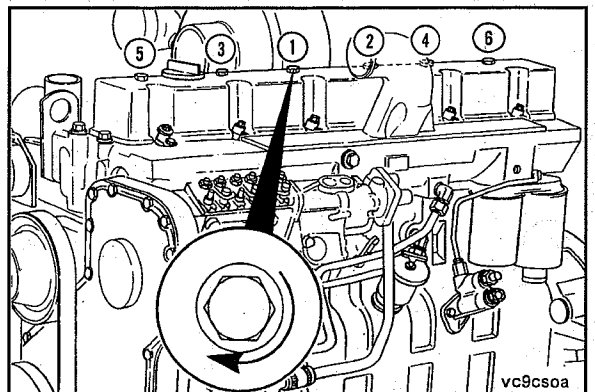

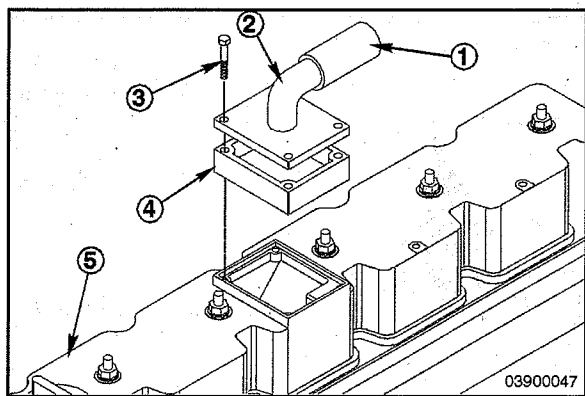

Install the Crankcase Breather Assembly components.

1. . Hose
2. . Breather
3. . Capscrew (self tapping)
4. . Mounting flange
5. . Rocker lever cover.

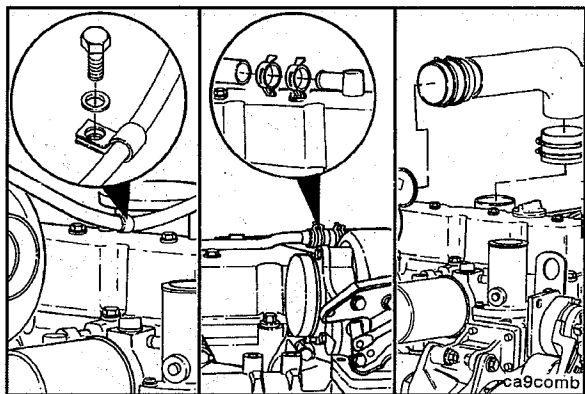

Finishing Steps

Install the capscrew into the support bracket for the turbocharger wastegate actuator hose (if installed).



Install the crankcase breather tube and hose. Refer to Procedure 003-018.

Install the air crossover tube (if installed).

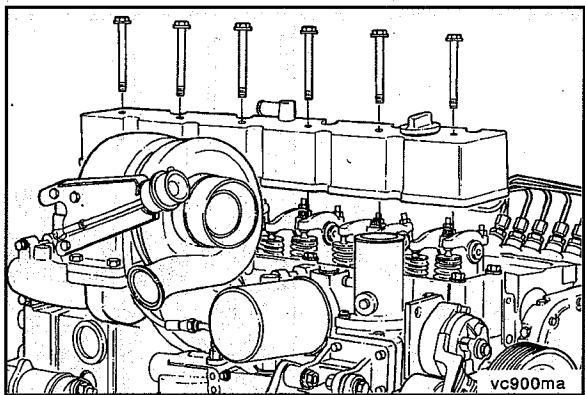

Overhead Set Preparatory Steps

Remove valve cover.

Refer to Procedure 003-011.

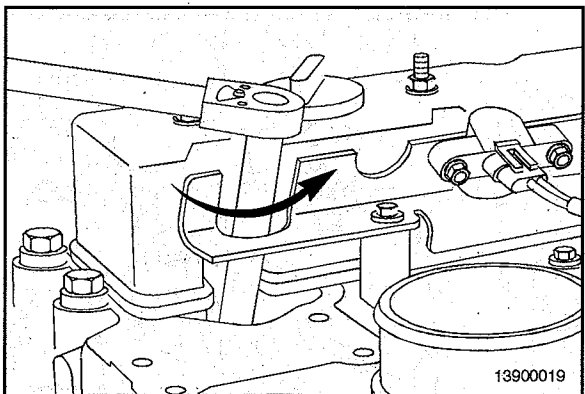

Remove number 1 spark plug.

Refer to Procedure 013-016.

To locate top dead center (TDC) for cylinder number 1 insert a small wooden dowel into the number 1 spark plug hole and rotate the engine until the engine is at top dead center (TDC).

The engine is at top dead center (TDC) if both number 1 rocker levers are loose.

If both rocker levers are **not** loose, rotate the crankshaft 360 degrees.

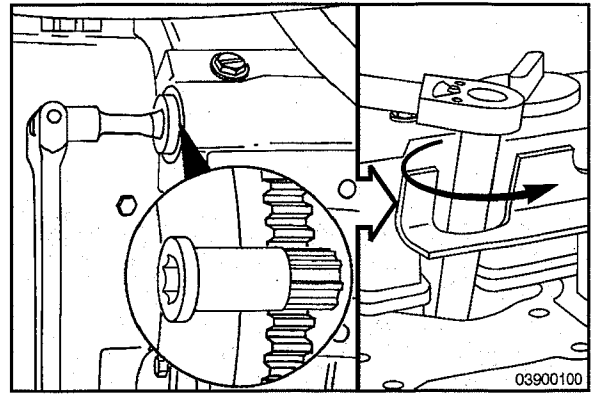

Adjust

Feeler Gauge

The clearance is correct when some resistance is felt when the feeler gauge is slipped between the valve stem and the rocker lever.

Intake Clearance: 0.305 mm [0.012 in]

Exhaust Clearance: 0.610 mm [0.024 in]

Check and set valves with engine cold - below 60 °C [140° F].

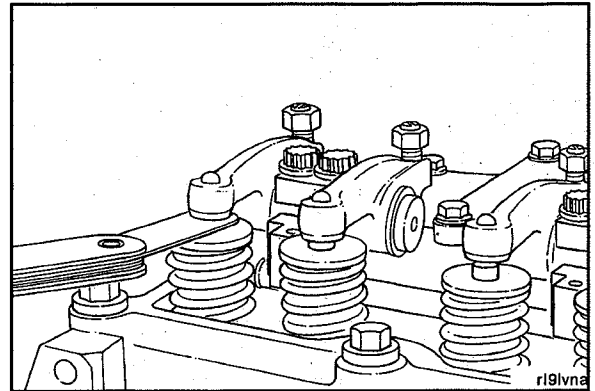

Check and adjust the valves indicated for STEP A (I = intake; E = exhaust).

After tightening the rocker lever locknut, check the valve clearance to make sure the valve clearance has **not** changed.

Torque Value: 24 N•m [212 in-lb]

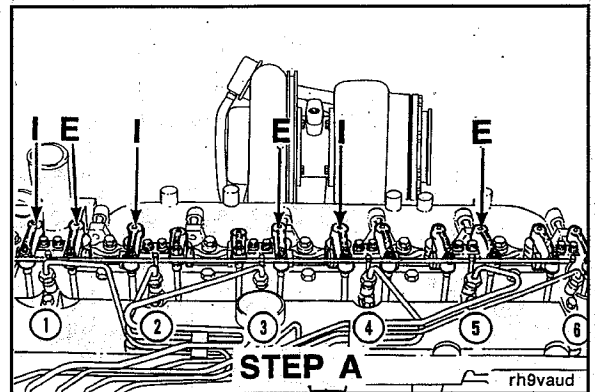

Mark the vibration damper and rotate the crankshaft 360 degrees.

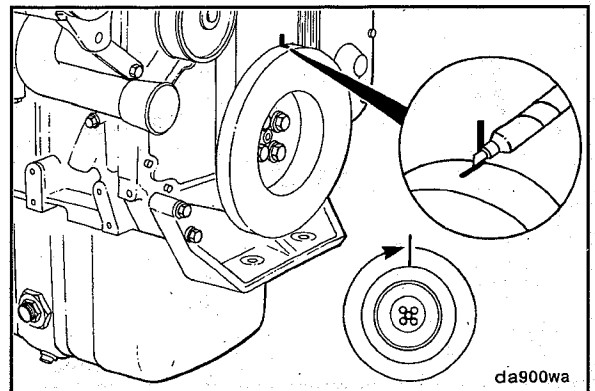

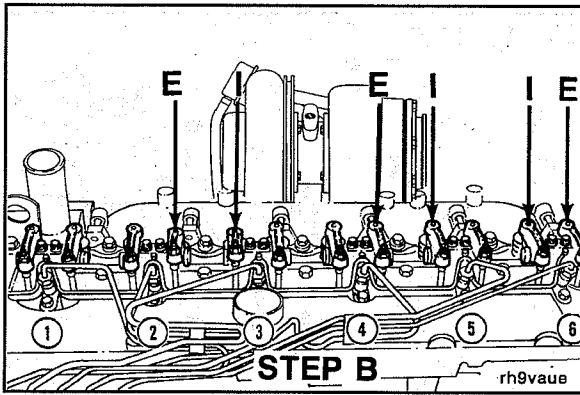

Set the valves indicated for Step B.

After tightening the rocker lever locknut, check the valve clearance to make sure the valve clearance has **not** changed.

Torque Value: 24 N•m [212 in-lb]

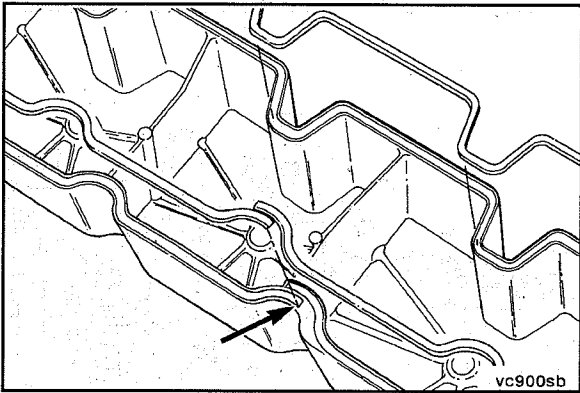

Finishing Steps

If the seal is **not** damaged, it can be used again. If the seal is damaged, install a new seal.

Install the rubber seal into the groove in the valve cover. Start the installation at the overlap area shown in the illustration. Do **not** stretch the rubber seal.

If the seal has more overlap than shown in the illustration, trim the length to provide the correct overlap.

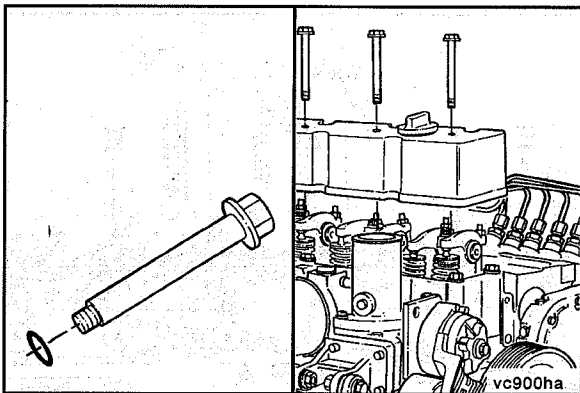

Install new sealing o-rings on the capscrews.

Refer to Procedure 003-011.

Install the valve cover.



Torque Value: 24 N•m [212 in-lb]

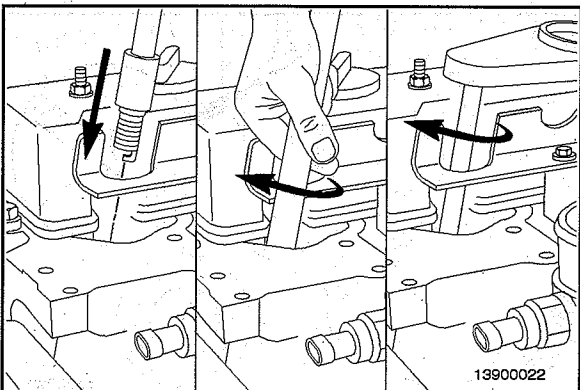

Install the spark plug.

Refer to Procedure 013-016.

Lubricating Oil and Filters

General Information

▲ WARNING ▲

Some state and federal agencies have determined that used engine oil can be carcinogenic and cause reproductive toxicity. Avoid inhalation of vapors, ingestion, and prolonged contact with used engine oil. If not reused, dispose of in accordance with local environmental regulations.

NOTE: Oil for natural gas engines does **not** darken and look dirty as diesel oil does. Use the recommended maintenance intervals to determine oil change requirements, **not** the oil's appearance.

Change the lubricating oil and filter(s) at the specified oil change intervals. Refer to Table 1, Oil Drain Intervals in Section 2 - Maintenance Guidelines to find the correct change interval for your application.

Change the oil and filter to remove the contaminants suspended in the oil.

NOTE: Drain the oil only when it is warm and the contaminants are in suspension.

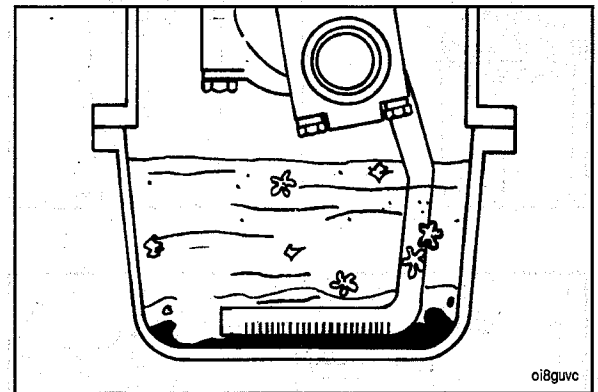

Drain

▲ WARNING ▲

To reduce the possibility of personal injury, avoid direct contact of hot oil with your skin.

▲ WARNING ▲

Some state and federal agencies have determined that used engine oil can be carcinogenic and cause reproductive toxicity. Avoid inhalation of vapors, ingestion, and prolonged contact with used engine oil. If not reused, dispose of in accordance with local environmental regulations.

Operate the engine until the water temperature reaches 70°C [158°F]. Shut the engine off.

NOTE: Use a container that can hold at least 25 liters [27 U.S. qts.] of oil.

Remove the drain plug.

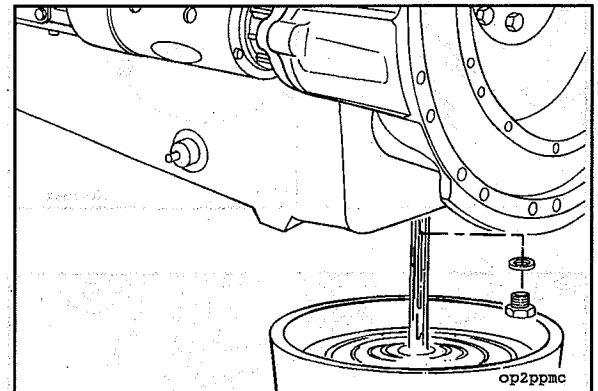

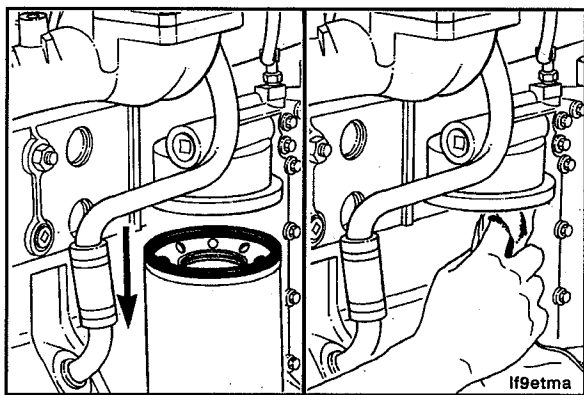

Remove

Remove the oil filter with filter wrench, Part Number 3375049.



Clean the area around the lubricating oil filter. Clean the gasket surface of the filter head.



NOTE: The o-ring can stick on the filter head. Make sure it is removed before installing the new filter.

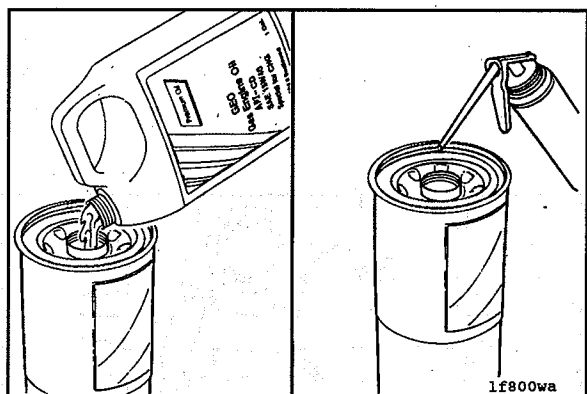

Install

Use the correct oil filter. Refer to Section V - Cummins/ Fleetguard™ Filter Specifications for the correct part number.

NOTE: Fill the filter with clean lubricating oil before installation. The lack of lubrication during the delay until the filter is pumped full of oil is harmful to the engine.

Apply a light film of lubricating oil to the gasket sealing surface before installing the new filter.

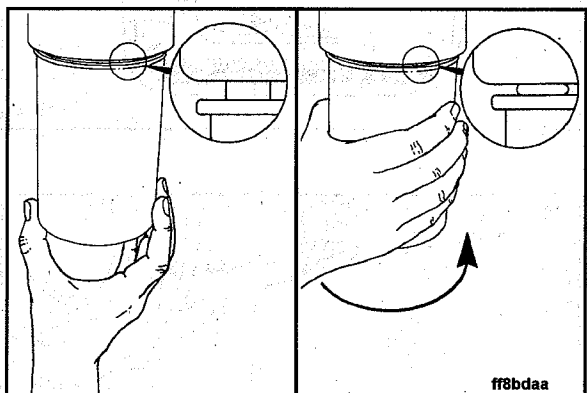

CAUTION

Mechanical overtightening can distort the threads or damage the lubricating oil filter element seal.

Install the oil filter. Turn the filter until the gasket contacts the filter head surface. Tighten the filter by hand an additional 1/2 to 3/4 of a turn after the gasket contacts the filter head surface, or as specified by the oil filter manufacturer.

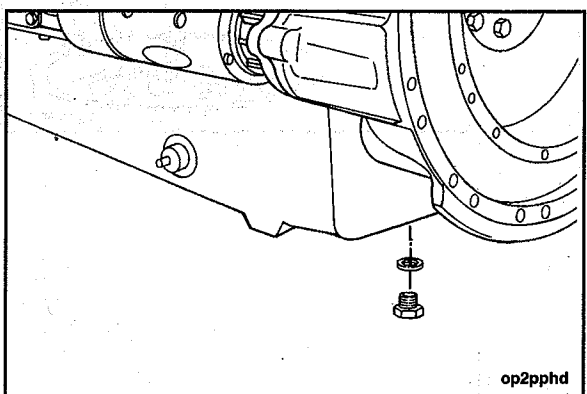

Check and clean the lubricating oil drain plug threads and sealing surface.



Install the oil pan drain plug.

Torque Value:

For steel stamp oil pans 80 N•m [59 ft-lb]



Fill

Use a high quality oil blend that meets Cummins specifications for natural gas engines. Refer to Section V - Lubrication Oil Specifications.

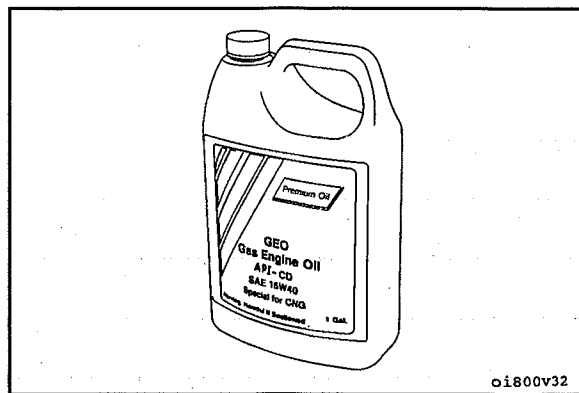

oi800v32

Fill the engine with clean lubricating oil to the proper level.



Oil Pan Capacity

Pan Capacity	18.9 Liters [20 U.S. qts.]
Total System Capacity	20.8 Liters [22 U.S. qts.]

NOTE: Total system capacity includes lubricating oil pan plus lubricating oil filter(s). Some applications use a slightly different lubricating oil pan capacity, and all lubricating oil quantities **must** be adjusted accordingly. Contact your Local Cummins Distributor if there is any questions.

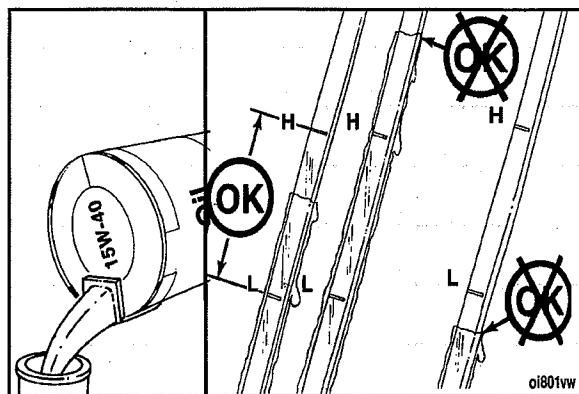

oi801vw

▲ WARNING ▲

If no oil pressure is noted within 15 seconds after the engine is started, shut down the engine to reduce the possibility of internal damage.

Operate the engine at idle to inspect for leaks at the lubricating oil filter and the drain plug.

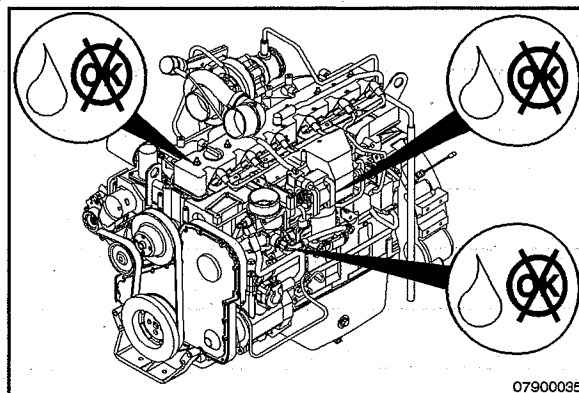

07900035

Stop the engine. Wait approximately 5 minutes to let the lubricating oil drain from the upper parts of the engine. Check the oil level again.



Add oil as necessary to bring the oil level to the H (high) mark on the dipstick.

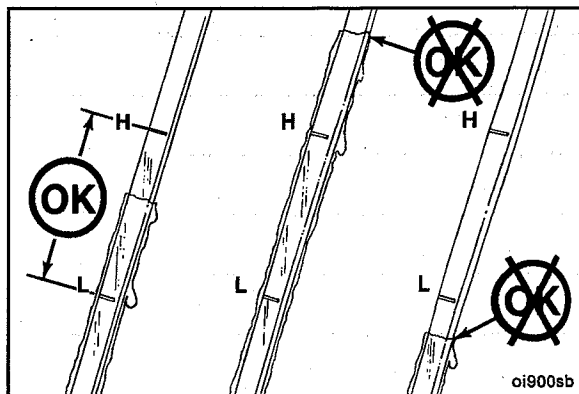

oi900sb

Section 5 - Maintenance Procedures at 750 Hours or 6 Months

Section Contents

	Page
Cooling Fan Belt Tensioner	5-2
Maintenance Check.....	5-2
Maintenance Procedures - Overview	5-1
General Information.....	5-1
Spark Plugs (Standard)	5-3
Clean and Inspect for Reuse.....	5-3
Install.....	5-4
Remove.....	5-3
Supplemental Coolant Additive (SCA) and Antifreeze Concentration	5-1
Maintenance Check.....	5-1
Supplemental Coolant Additive (SCA).....	5-1
Antifreeze.....	5-1

This Page Left Intentionally Blank

Maintenance Procedures - Overview

General Information

All maintenance checks and inspections listed in previous maintenance intervals **must** also be performed at this time, in addition to those listed under this maintenance interval.

Supplemental Coolant Additive (SCA) and Antifreeze Concentration

Maintenance Check

Supplemental Coolant Additive (SCA)

Check the SCA concentration level:

- At least twice a year
- At every subsequent oil drain interval if the concentration is above 3 units
- Whenever coolant is added to the cooling system between filter changes.

Use Fleetguard® coolant test kit, Part No. CC2602, to check the SCA concentration level. Instructions are included with the test kit. Refer to Coolant Recommendations and Specifications in Maintenance Specifications (Section V) for the correct SCA and antifreeze level.

Antifreeze



Overconcentration of antifreeze or use of high-silicate antifreeze can damage the engine.

Check the antifreeze concentration. Use a mixture of 50-percent water and 50-percent ethylene glycol or propylene glycol-based antifreeze to protect the engine to -32°C [-26°F] year-around.

The Fleetguard® refractometer, Part Number C2800, provides a reliable, easy-to-read, and accurate measurement of freezing point protection and glycol (antifreeze) concentration.

Antifreeze is essential in every climate.

Antifreeze broadens the operating temperature range by lowering the coolant freezing point and by raising its boiling point.

The corrosion inhibitors also protect the cooling system components from corrosion and prolong component life.

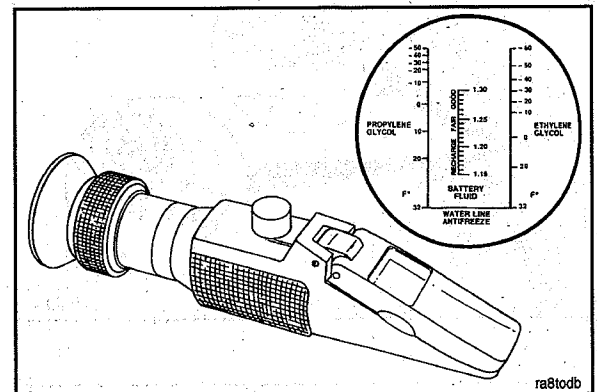
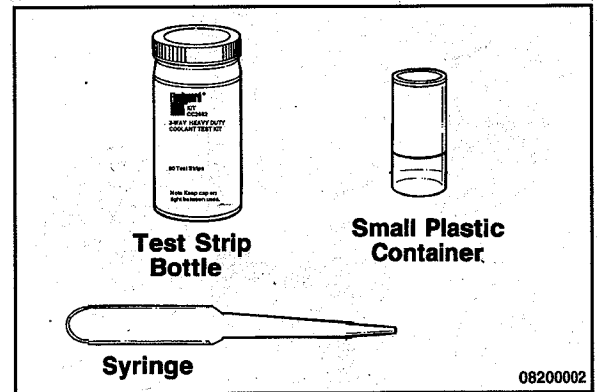

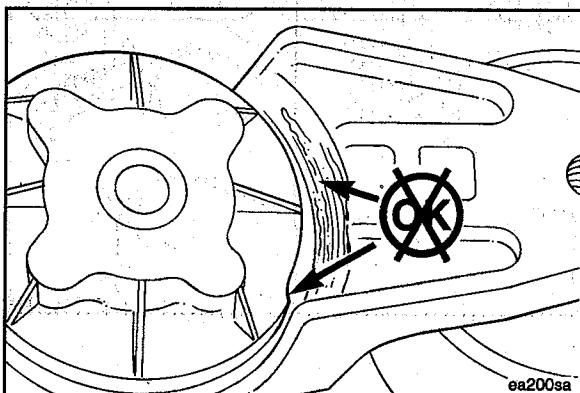
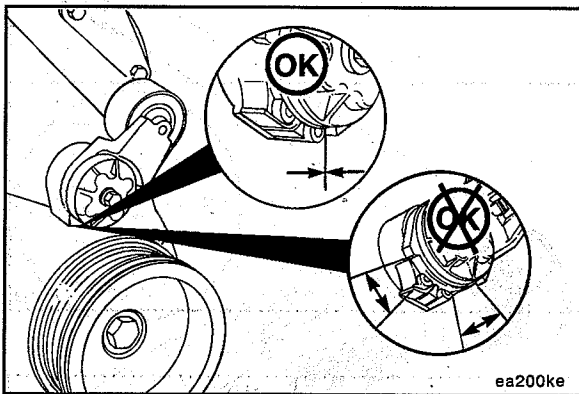
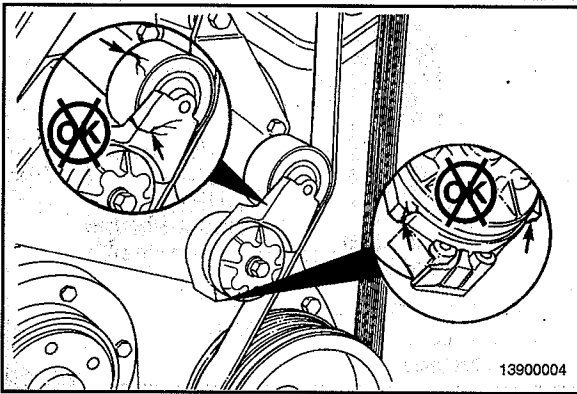
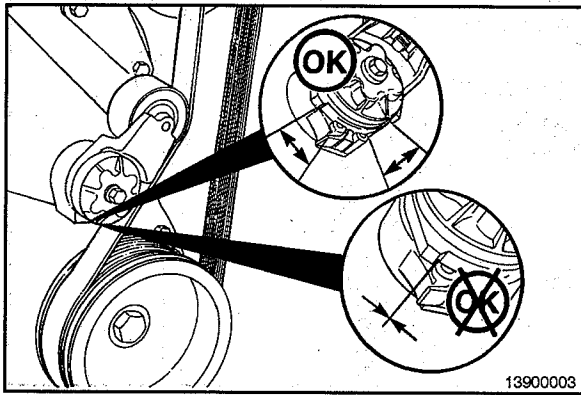

Cooling Fan Belt Tensioner Maintenance Check

With the engine turned off, check that neither the top nor bottom tensioner arm stop is touching the cast boss on the tensioner body. If either of the stops is touching a boss, the alternator belt **must** be replaced. Check to make certain the correct belt part number is being used if either condition exists.



▲ WARNING ▲

When using a steam cleaner, wear safety glasses or a face shield, as well as protective clothing. Hot steam can cause serious personal injury.



▲ WARNING ▲

Wear safety glasses or a face shield, as well as protective clothing, to prevent personal injury when using a steam cleaner or high-pressure water.



Check the tensioner pulley and body for cracks. If any cracks are noticed, the tensioner **must** be replaced. Refer to a Cummins Authorized Repair Facility.

Check the tensioner for dirt buildup. If this condition exists, the tensioner **must** be removed and steam-cleaned.



With the cooling fan belt removed, check that the bottom tensioner arm stop is in contact with the bottom tensioner arm stop boss on the tensioner body. If these two are **not** touching, the tensioner **must** be replaced.



Inspect the tensioner for evidence of the pivoting tensioner arm contacting the stationary circular base. If there is evidence of these two areas touching, the pivot tube bushing has failed and the tensioner **must** be replaced.

The worn tensioner that has play in it or a belt that "walks" off its pulley possibly indicates pulley misalignment.

NOTE: Maximum pulley misalignment is 3 degrees.

This measurement can be taken with a straightedge and an inclinometer.

Install the belt.

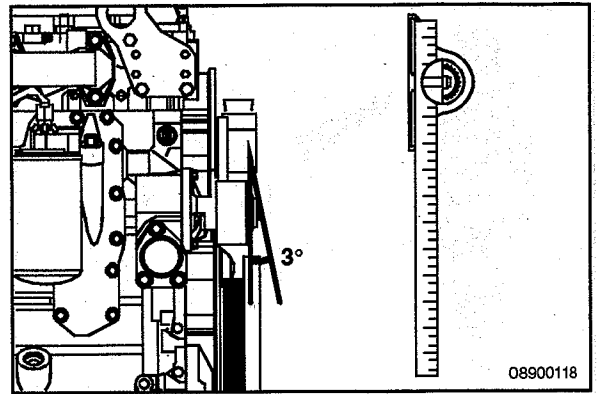

Spark Plugs (Standard)

Remove

NOTE: Shown throughout this procedure is the QSK19G engine. Although different in appearance, the procedure remains the same.

Disconnect the spark plug wire (1) from the ignition coil and remove the spark plug adapter (2).

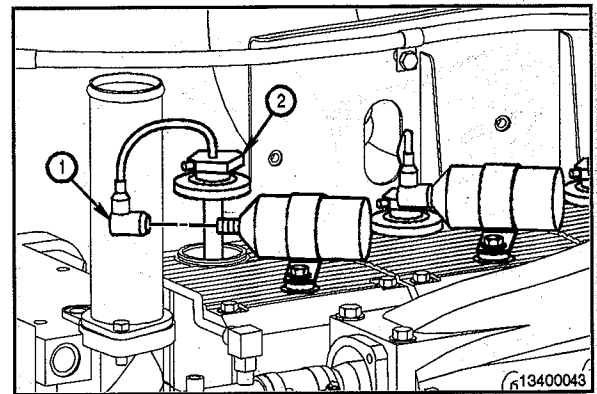

⚠ CAUTION ⚠

Do not let the spark plug fall into its well. Damage to the insulator can result. If the spark plug falls into the well, replace it with a new spark plug.

Using the spark plug socket, Part Number 3162231, and a wrench, remove the spark plug.

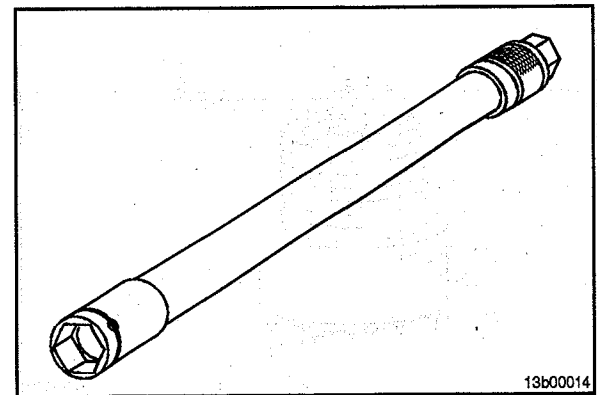

Clean and Inspect for Reuse

⚠ WARNING ⚠

When using solvents, acids, or alkaline materials for cleaning, follow the manufacturer's recommendations for use. Wear goggles and protective clothing to reduce the possibility of personal injury.

Spark plugs **must** always be kept clean. Never touch the porcelain of the spark plug. If the porcelain becomes dirty, it **must** be cleaned before installation. Cleaning can be done with rubbing alcohol and a clean cloth.

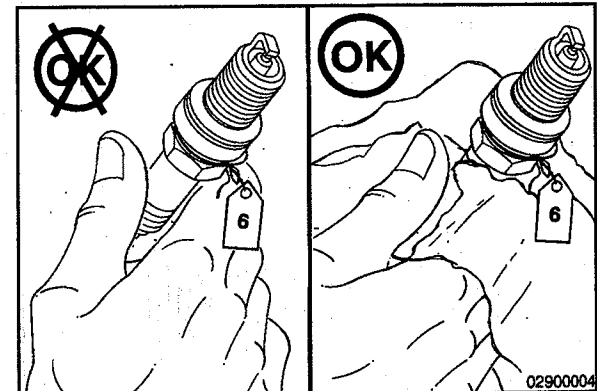

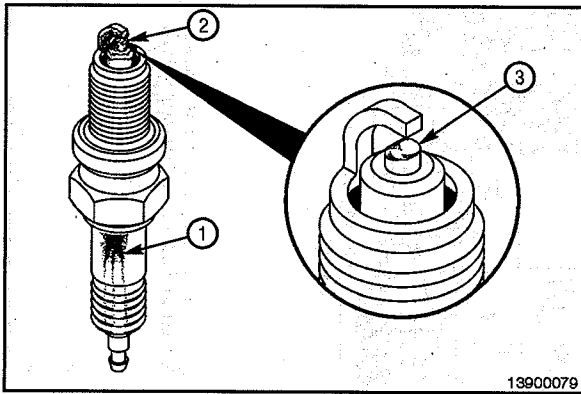

Inspect the spark plug for the following:

1. Insulator flashover
2. Electrode deposits or fouling
3. Worn or missing electrode.

If a spark plug exhibits any of these, the spark plug must be replaced.

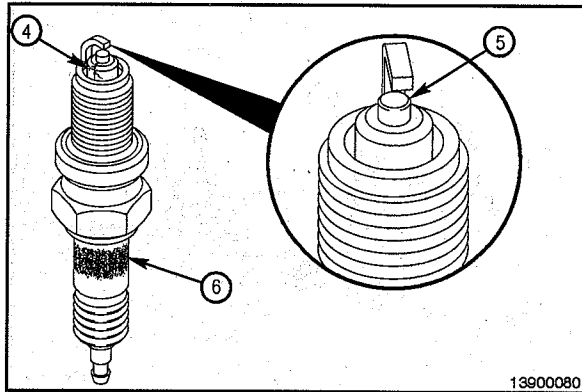

Inspect the spark plug for the following:

4. Cracked insulator
5. Electrode misalignment
6. Corona marks.

If a spark plug exhibits any of these, the spark plug must be replaced.

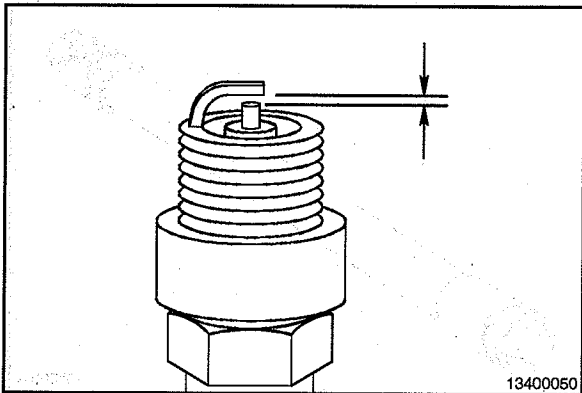

Install

CAUTION



Do not force a feeler gauge into the spark plug gap. This will damage the precious metal electrodes and shorten the spark plug life.

The spark plug can be serviced up to a maximum of three times.

Always replace the gasket, Part Number 3072541, whenever the spark plug is removed from the cylinder head.

Always inspect the gap of new spark plugs. The gap must be set to:

- KTA19-GC: 0.381 mm [0.015 in]
- All other mechanically controlled fuel system engines: 0.508 mm [0.020 in].

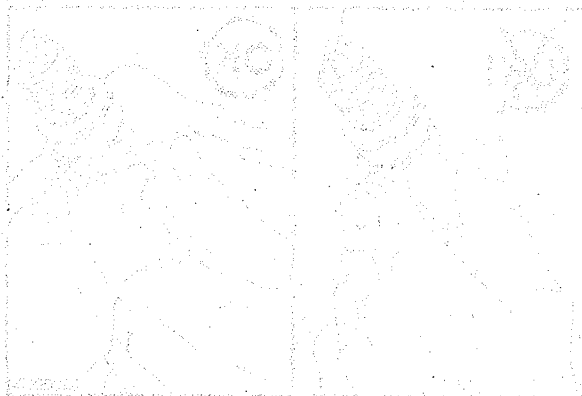

Adjust the gap by bending the ground (side) electrode using the slots on the gap tool. Align the center and ground electrode. The ground electrode **must** be parallel and centered over the middle of the electrode.

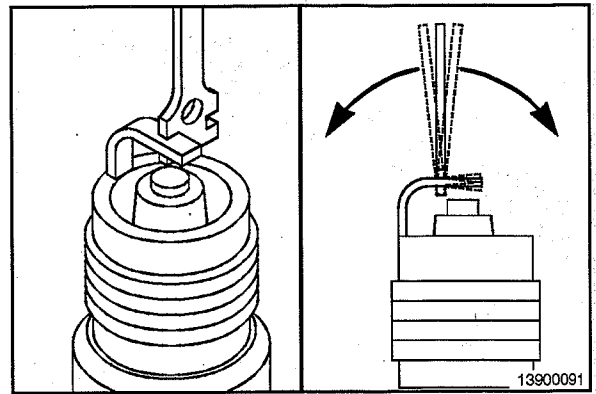

The spark plug socket used for installation **must** also be kept clean. Do **not** use a spark plug socket with a rubber insert. Rubber inserts can contaminate the spark plugs that you have just cleaned. Socket, Part Number 3162231, has a clip retainer at the bottom to hold the spark plug without contaminating the porcelain.

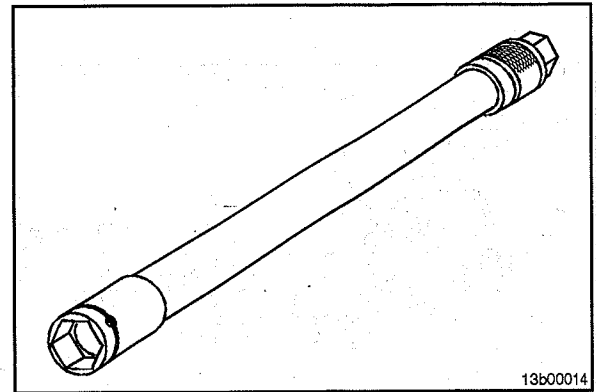

Spark plug threads have anti-seize plating. Anti-seize compound is generally conductive and **must not** be used on spark plugs.

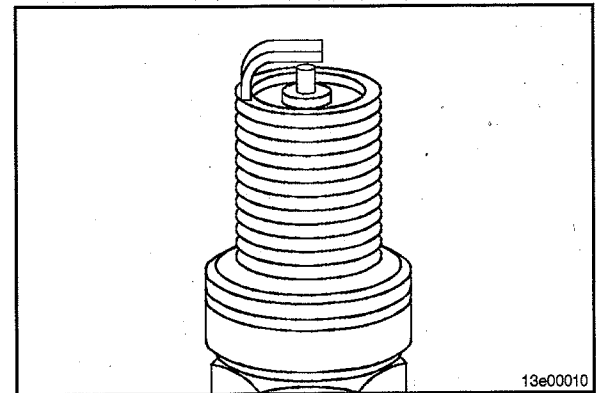

Install the spark plugs.

Spark plugs **must always** be tightened to the correct torque value. On a hot engine, tighten all of the spark plugs hand tight before tightening the first spark plug with a torque wrench. This will allow all of the spark plugs to warm up to the cylinder head temperature prior to tightening.

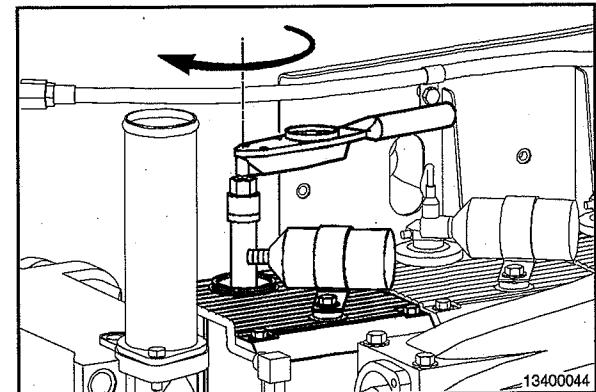

Spark Plug Torque		
N•m		ft-lb
49	MIN	36
54	MAX	40

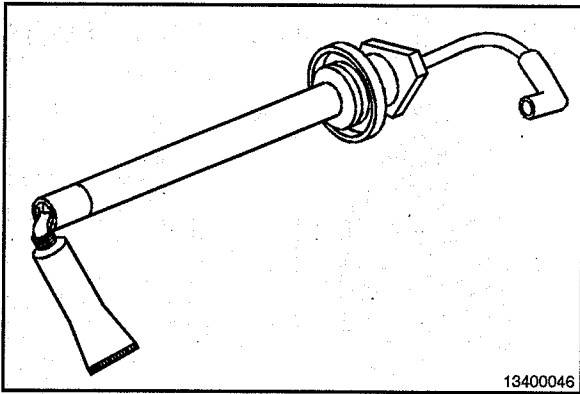

△CAUTION△

Never use Cummins Lubriplate™ in or on a spark plug adapter boot. Lubriplate™ is a conductor and its use can lead to spark plug flashover, resulting in engine damage.

Cummins Inc. recommends the following dielectric grease:

- Dupont Krytox 205, Cummins Part Number 3164956.

Always apply a pea-sized amount of dielectric lubricant to the spark plug adapter boot prior to installation. The approved dielectric grease is Cummins Part Number 3164956 or Dupont Krytox 205. This adds to the dielectric seal of the rubber boot and reduces the possibility of the boot melting onto the spark plug.

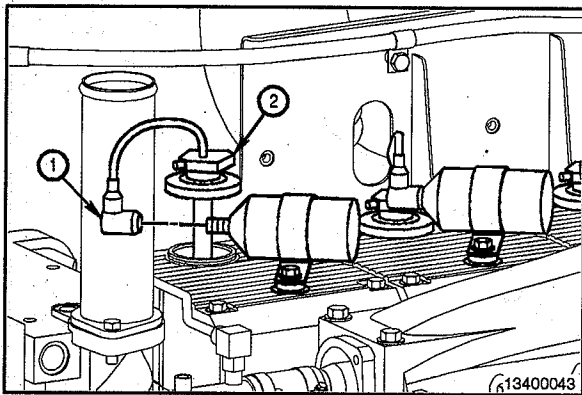

Install the spark plug adapter (2).

Install the spark plug wire (1) onto the ignition coil.

Section 6 - Maintenance Procedures at 1500 Hours or 1 Year

Section Contents

	Page
Air Cleaner Element, Paper Type	6-25
General Information.....	6-25
Air/Fuel Mixer	6-17
Adjust.....	6-22
Clean and Inspect for Reuse.....	6-20
Finishing Steps.....	6-21
General Information.....	6-17
Install.....	6-21
Preparatory Steps.....	6-19
Remove.....	6-19
Batteries	6-1
Inspect.....	6-1
Battery Cables and Connections	6-2
Initial Check.....	6-2
Engine Mounts	6-3
Inspect for Reuse.....	6-3
Governor Oil	6-12
Drain.....	6-12
Fill.....	6-12
Engine Steam Cleaning	6-11
Clean.....	6-11
Fuel Filter, NG	6-23
Finishing Steps.....	6-24
Install.....	6-24
Preparatory Steps.....	6-23
Remove.....	6-23
Ignition Timing	6-15
Adjust.....	6-15
Electro-Mechanical Type.....	6-16
Electronic Type.....	6-17
Low-Temperature Aftercooler (LTA) Water Pump	6-3
Clean and Inspect for Reuse.....	6-5
Finishing Steps.....	6-7
Initial Check.....	6-3
Install.....	6-6
Preparatory Steps.....	6-3
Remove.....	6-4
Coolant Filter	6-9
Clean.....	6-10
Install.....	6-10
Remove.....	6-9
Maintenance Procedures - Overview	6-1
General Information.....	6-1
Overhead Set	6-13
Adjust.....	6-13
Finishing Steps.....	6-14
Preparatory Steps.....	6-13
Radiator Hoses	6-24
Maintenance Check.....	6-24
Spark Plug Wire	6-8
Clean and Inspect for Reuse.....	6-8
Install.....	6-9
Remove.....	6-8

This Page Left Intentionally Blank

Maintenance Procedures - Overview

General Information

All maintenance checks and inspections listed in previous maintenance intervals **must** also be performed at this time, in addition to those listed under this maintenance interval.

Batteries

Inspect

Use an inductive charging and cranking system analyzer to load-test the state of charge of maintenance-free batteries. If the state of charge is low, use a battery charger to charge the battery. Refer to the manufacturer's instructions.

Replace the battery if it will **not** charge to the manufacturer's specifications or the battery will **not** maintain a charge.

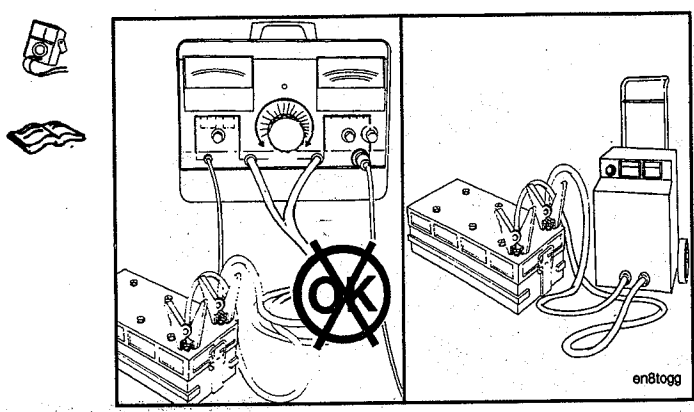

If conventional batteries are used, remove the cell caps or covers and check the electrolyte (water and sulfuric acid solution) level.

▲ WARNING ▲

Batteries can emit explosive gas. To reduce the possibility of personal injury, always ventilate the compartment before servicing the batteries. To reduce the possibility of arcing, remove the battery (-) negative cable first and attach the battery negative cable last.

NOTE: Maintenance-free batteries are sealed and do not require the addition of water.

Fill each battery cell with water. Refer to the manufacturer's specifications.

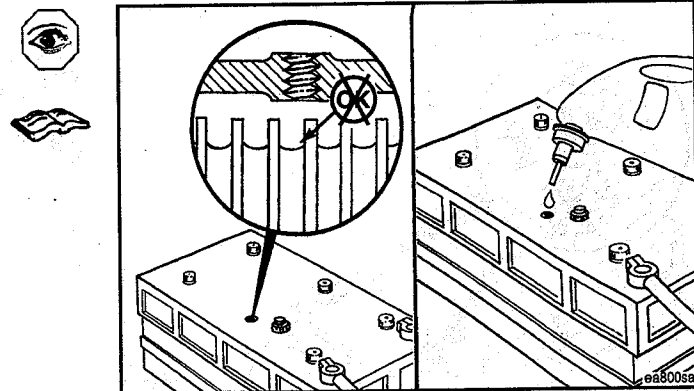

Refer to the accompanying table to determine the battery state of charge based on the specific-gravity readings.

Battery State of Charge	Specific Gravity @ 27°C [80°F]
100%	1.260 to 1.280
75%	1.230 to 1.250
50%	1.200 to 1.220
25%	1.170 to 1.190
Discharged	1.110 to 1.130

▲ WARNING ▲

Batteries can emit explosive gases. To reduce the possibility of personal injury, always ventilate the compartment before servicing the batteries. To reduce the possibility of arcing, remove the negative (-) battery cable first and attach the negative (-) battery cable last.

Install the cables and tighten the battery connections.
Coat the terminals with grease to prevent corrosion.

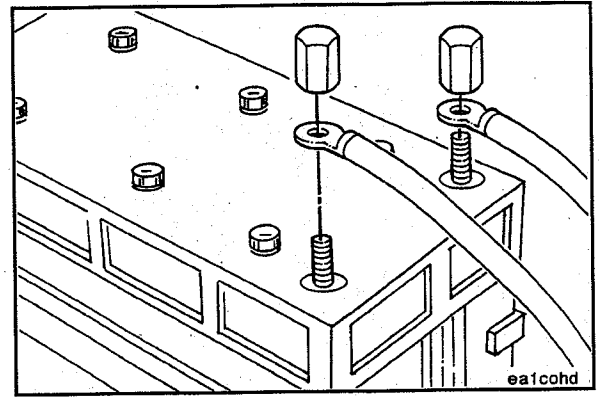

Engine Mounts
Inspect for Reuse

▲ CAUTION ▲

Damaged engine mounts and brackets can cause engine misalignment. Drivetrain component damage will possibly result in vibration complaints.

Inspect all rubber-cushioned mounts for cracks or damage.

Inspect all mounting brackets for cracks or damaged bolt holes.

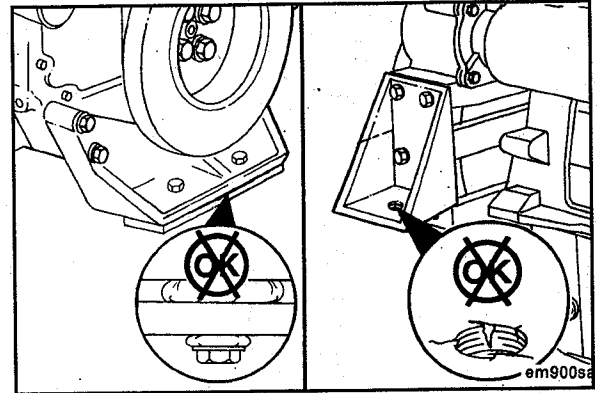

Low-Temperature Aftercooler (LTA)
Water Pump
Initial Check

Seal Leakage

Inspect the water pump for evidence of water or oil, indicating seal leakage. If seal leakage is evident, the pump **must** be repaired or replaced.

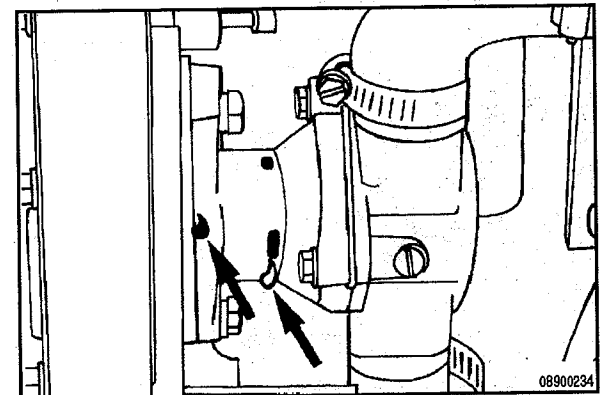

Preparatory Steps

Shut the Low Temperature Aftercooler (LTA) Water Pump inlet valve.

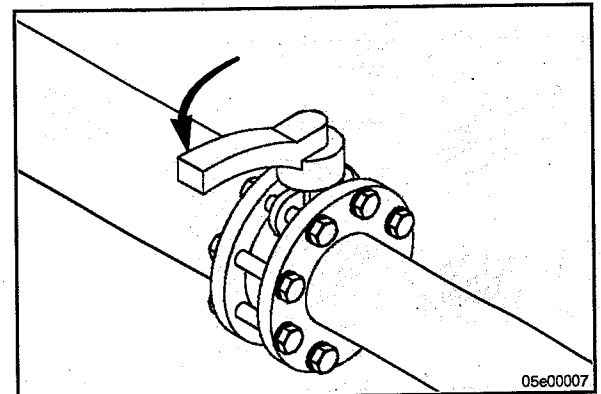

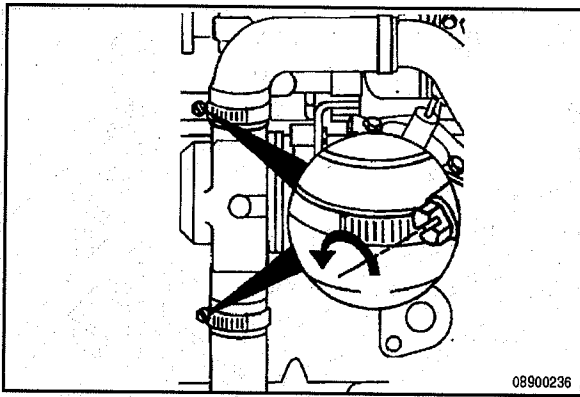

Remove the inlet and outlet hose and drain the water from the pump.

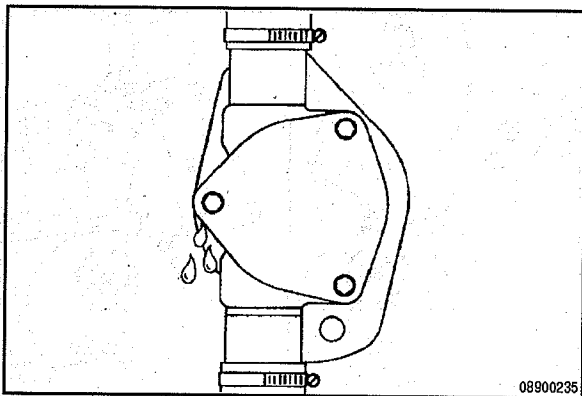

Remove

CAUTION

If the impeller has failed and pieces are missing, all pieces must be retrieved. The engine heat exchanger, gear oil cooler, and aftercooler (if equipped) must be flushed. Refer to the procedures for flushing these components in other headings of this section. Failure to do so can result in overheating and damage to engine can occur.

Impeller debris can also drop into the inlet piping. Make sure all debris is removed before installing a new impeller; otherwise, additional impeller failures or engine overheating will occur.

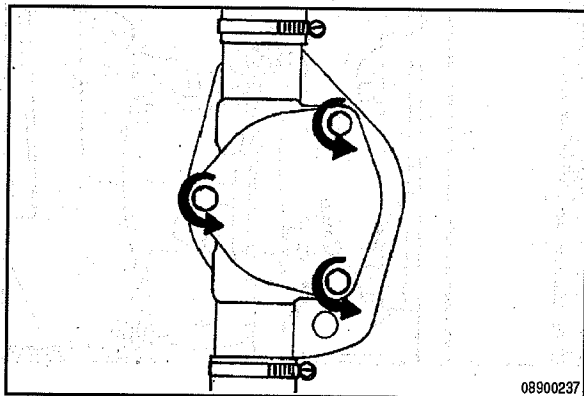

Remove the capscrews. Lift off the cover.

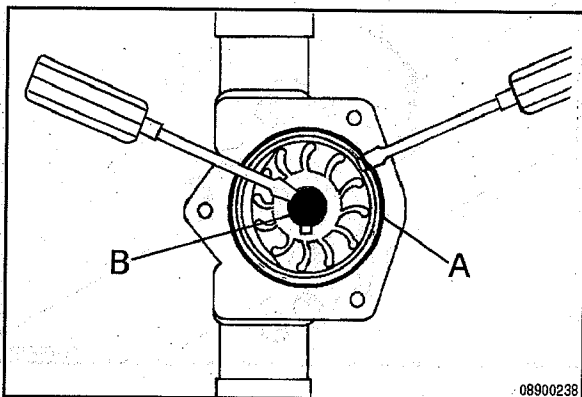

Use a small screwdriver to remove the o-ring (A).

Use a small screwdriver to remove the inner cap (B).

Clean the o-ring groove.



⚠CAUTION⚠

Do not pry against the pump housing to remove the impeller as this can cause damage to the liner.

Be sure to note the direction of impeller fins for proper installation. Mark the outer surface.

An impeller removal tool is available from Sherwood Pumps, Part Number 23631.

If the impeller is equipped with a threaded insert, use the special tool or a 3/4-NFT bolt (1) to insert in the impeller to pull the impeller out.

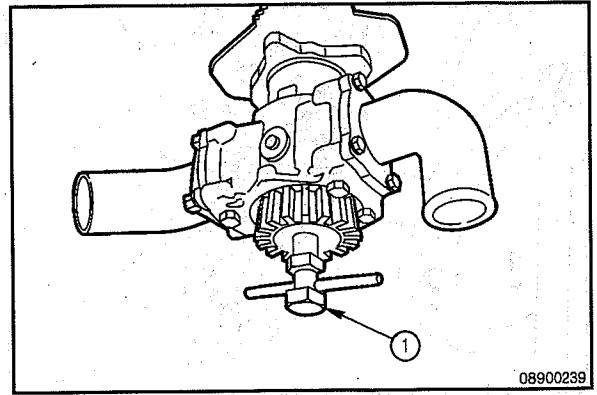

08900239

Be sure to note the direction of impeller fins for proper installation. Mark the outer surface.

If the impeller does **not** have a threaded bore, grasp the hub of the impeller with pliers and remove the impeller from the impeller bore.

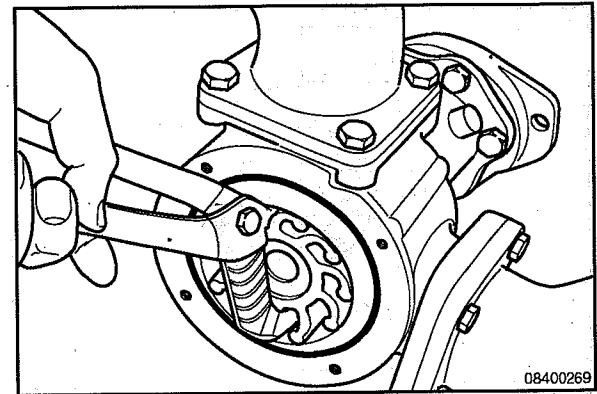

08400269

Clean and Inspect for Reuse

Inspect for damage such as rips, tears, chunks of material missing, or wear on the edges of the blades.

Replace as necessary.

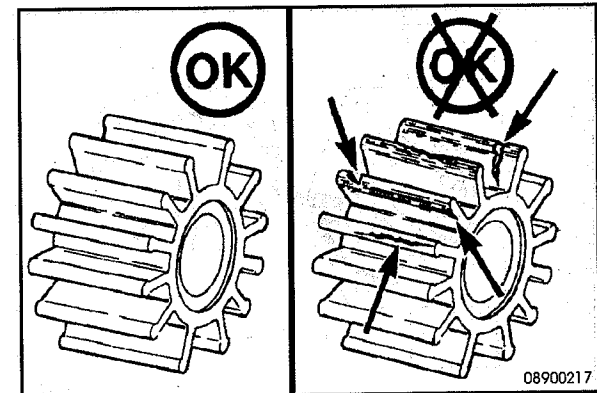

08900217

Clean the internal pump surfaces.

Lubricate the housing with silicone or glycerine non-petroleum-based lubricant. Petroleum-based lubricant will damage the rubber impeller.

If non-petroleum-based lubricant is **not** readily available, use soapy water to ease installation.

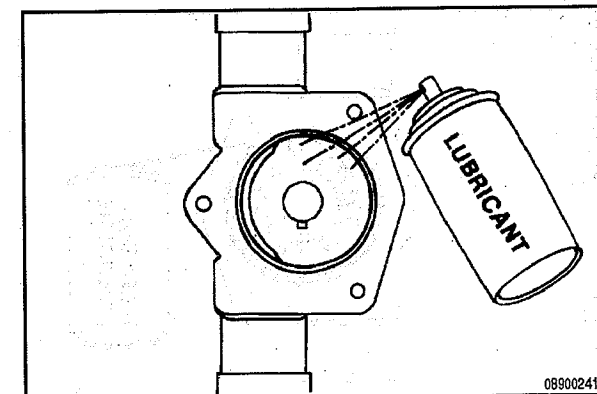

08900241

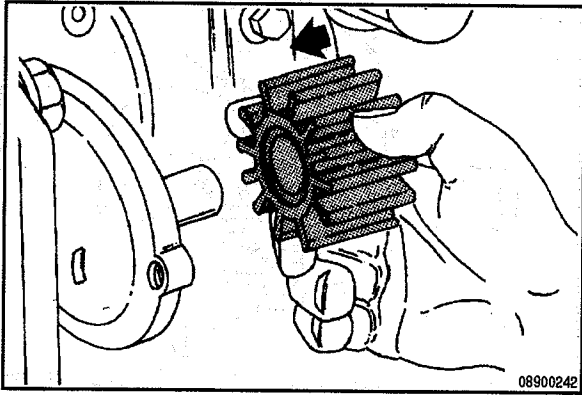

Install

If the impeller is in good shape and will be reused, install it in the same direction from which it was removed. Refer to the mark you made during removal.



If the impeller was **not** marked and the original rotation or direction can **not** be determined, replace the impeller with a new one.

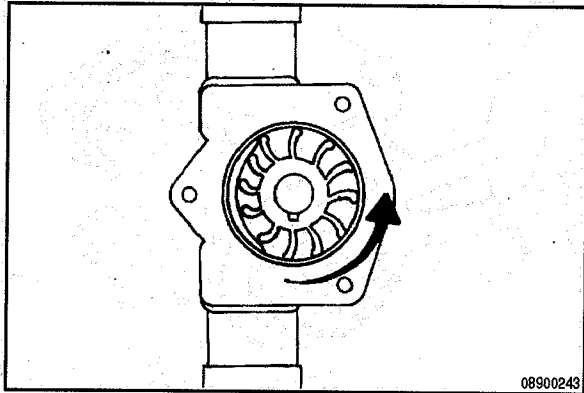

An oil filter strap wrench or even plastic wire straps can be used as an installation aid to hold the vanes.

Guide the impeller into the housing, twisting it **counterclockwise** as it is advanced so that the vanes will be deflected in the proper direction.

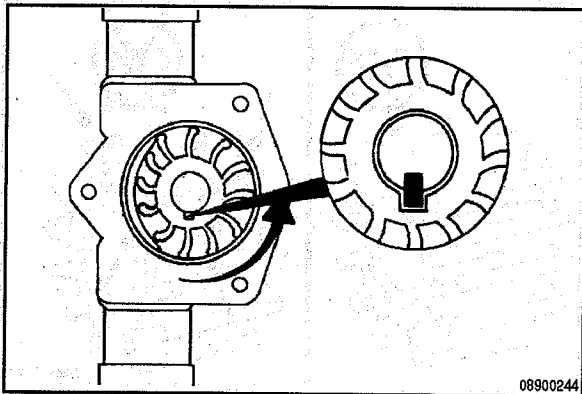

Continue to turn the impeller while pushing it into the housing. It will slide all the way in when the keyway lines up with the key.

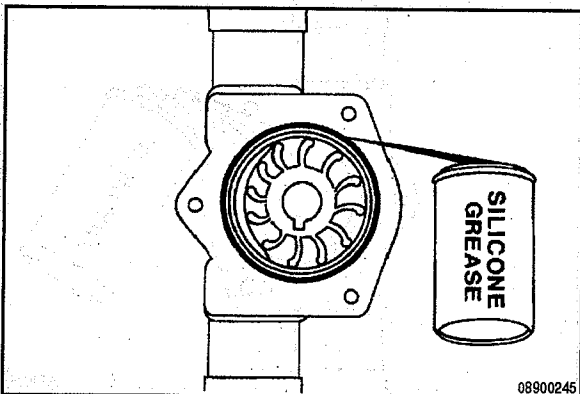

Insert the new o-ring into the impeller housing. Use a little silicone grease to hold it in place.

G8.3 Series Engine
Section 6 - Maintenance Procedures at 1500 Hours or 1 Year

Install the rubber impeller cap into the center hub of the impeller.

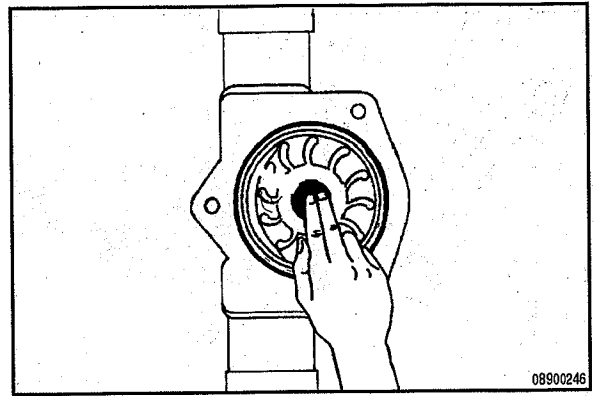

Install a new gasket, cover plate, and capscrews.

Tighten the capscrews.

Torque Value: 24 N•m [212 in-lb]

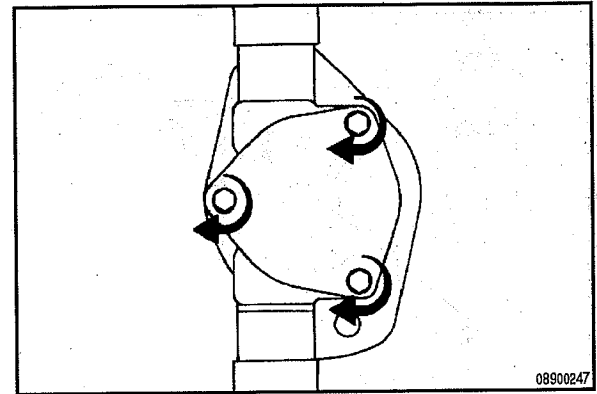

Finishing Steps

Install the inlet and outlet hose to the pump.

Open the Low Temperature Aftercooler (LTA) Water Pump inlet valve and check for leaks.

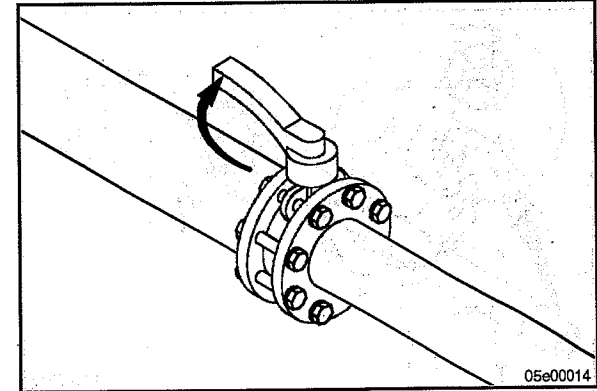

Check the Low Temperature Aftercooler (LTA) Water Pump and plumbing for leaks.

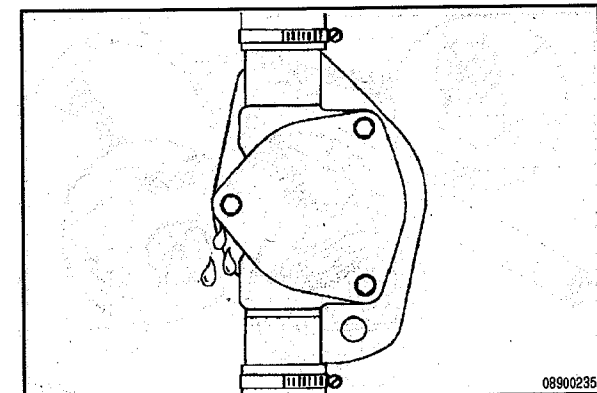

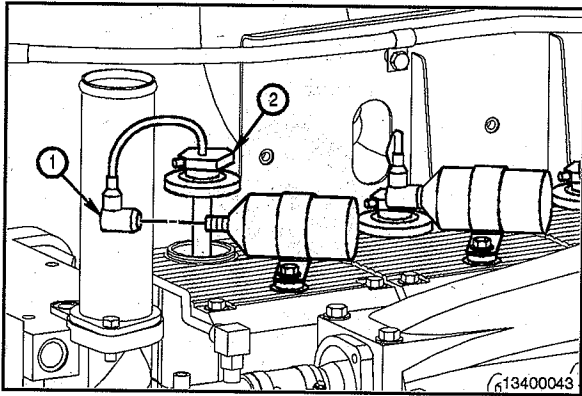

Spark Plug Wire Remove

Disconnect the spark plug wire (1) from the ignition coil and remove the spark plug adapter (2).

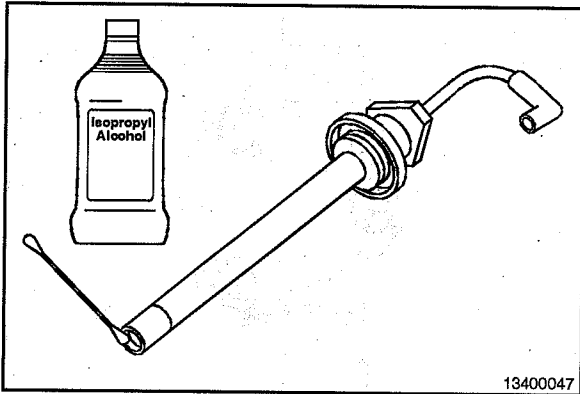

Clean and Inspect for Reuse

Using a lint free cloth or cotton swab and isopropyl alcohol, clean any excess or residue of the dielectric lubricant from the spark plug adapter boot.

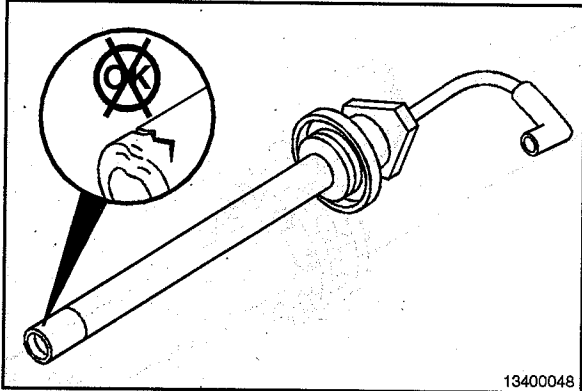

Inspect the spark plug adapter boot for melting and cracks.

Inspect the spark plug adapter for any cracks and spark carryover.

If any damage is found, replace the spark plug adapter and wire.

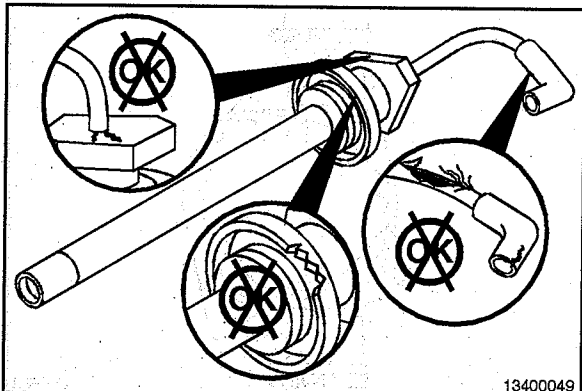

Check the spark plug wire for breaks or fraying.

Check the spark plug adapter rubber boot for damage.

If any damage is found, replace the spark plug adapter and wire.

Install

▲ CAUTION ▲

Never use Cummins Lubriplate™ in a spark plug adapter or ignition wire boot. Lubriplate™ is a conductor and its use can lead to spark plug flashover, resulting in engine damage.

Always apply a small amount of dielectric lubricant to the spark plug adapter boot prior to installation. Dow Corning® Number 4 insulating compound or GE G624 can be used. Outside the United States, if Dow Corning® Number 4 or GE G624 is not available, use Dow Corning® Number 111 valve lubricant and sealant. This adds to the dielectric seal of the rubber boot and reduces the possibility of the boot melting onto the spark plug.

Install the spark plug adapter (2).

Install the spark plug wire (1) onto the ignition coil.

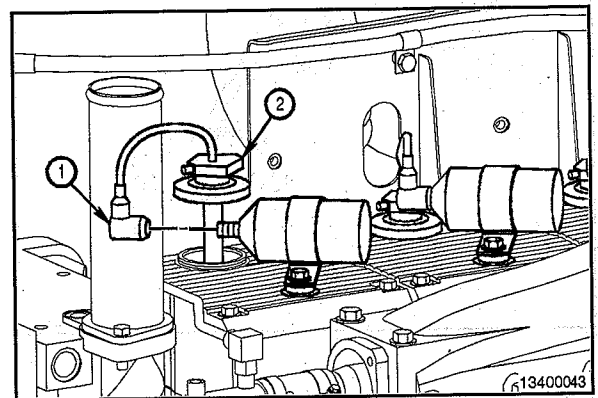
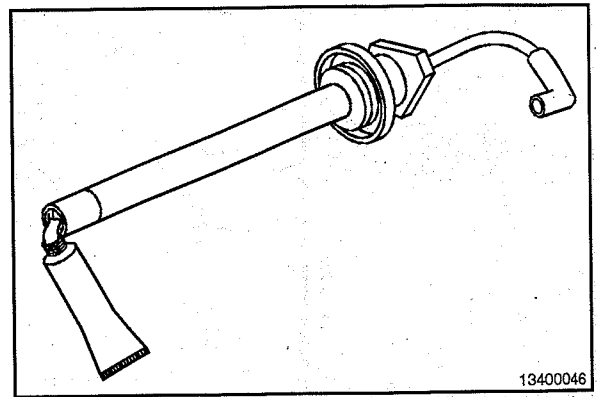

Coolant Filter

Remove

▲ WARNING ▲

Do not remove the pressure cap from a hot engine. Wait until the coolant temperature is below 50°C [120°F] before removing the pressure cap. Heated coolant spray or steam can cause personal injury.

Turn the shutoff valve to the OFF position by rotating the knob from vertical to horizontal in the direction shown.

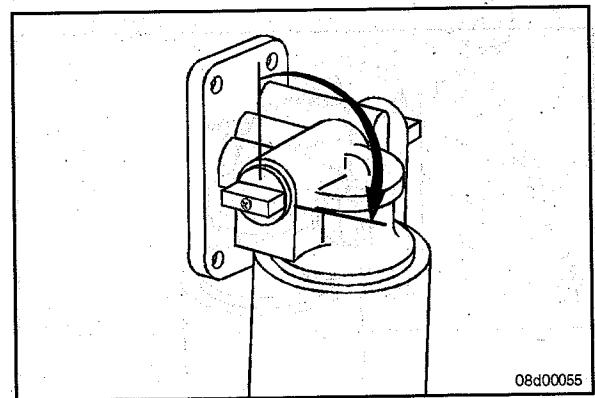

▲ WARNING ▲

A small amount of coolant can leak when servicing the coolant filter with the shutoff valve in the OFF position. To reduce the possibility of personal injury, avoid contact with hot coolant.

▲ WARNING ▲

Coolant is toxic. Keep away from children and pets. If not reused, dispose of in accordance with local environmental regulations.

Remove and discard the coolant filter.

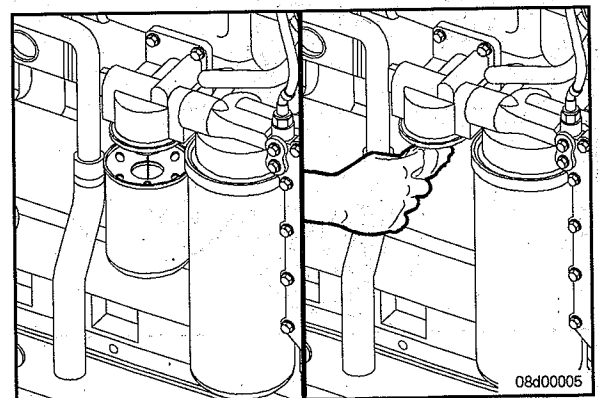

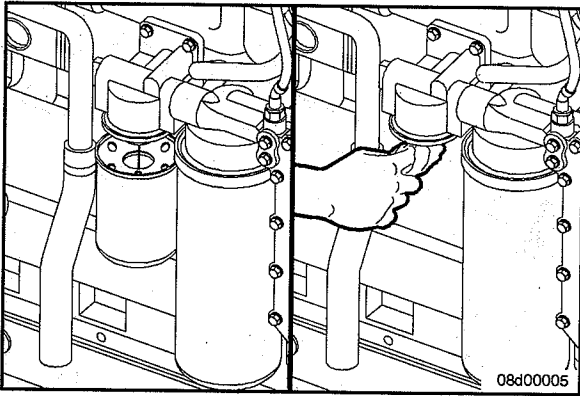

Clean

Clean the gasket surface.

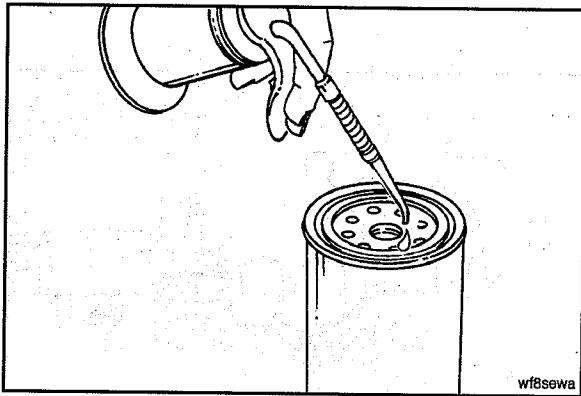

Install

⚠ CAUTION ⚠

Do not allow oil to get into the filter. Oil will damage the DCA.



⚠ CAUTION ⚠

Mechanical overtightening can distort the threads or damage the filter head.



Apply a thin film of lubricating oil to the gasket sealing surface before installing the new coolant filter.

Install the coolant filter on the filter head. Tighten the filter until the gasket contacts the filter head surface.

Tighten the coolant filter an additional 1/2 to 3/4 of a turn, or as specified by the filter manufacturer.

⚠ CAUTION ⚠

The valve must be in the ON position to prevent engine damage.

Turn the shutoff to the ON position by rotating the knob from horizontal to vertical in the direction shown.

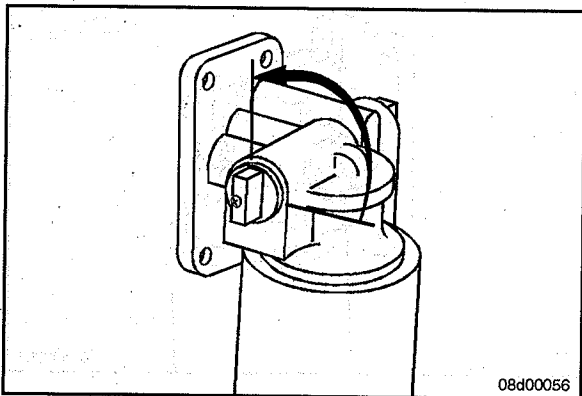

G8.3 Series Engine
Section 6 - Maintenance Procedures at 1500 Hours or 1 Year

Install the coolant system pressure cap.

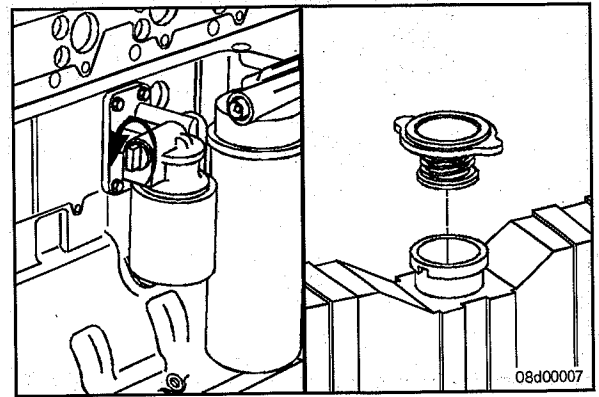

Operate the engine and check for coolant leaks.
After the air has been purged from the system, check the coolant level again.

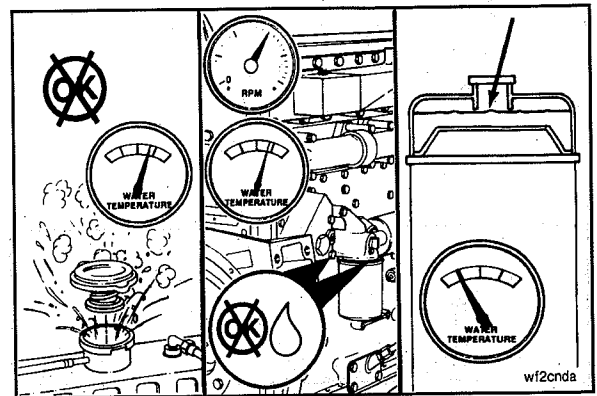

Engine Steam Cleaning Clean

▲ WARNING ▲

When using a steam cleaner, wear safety glasses or a face shield, as well as protective clothing. Hot steam can cause serious personal injury.

Steam is the best method of cleaning a dirty engine or a piece of equipment. If steam is not available, use a solvent to wash the engine.

Protect all electrical components, openings, and wiring from the full force of the cleaner spray nozzle.

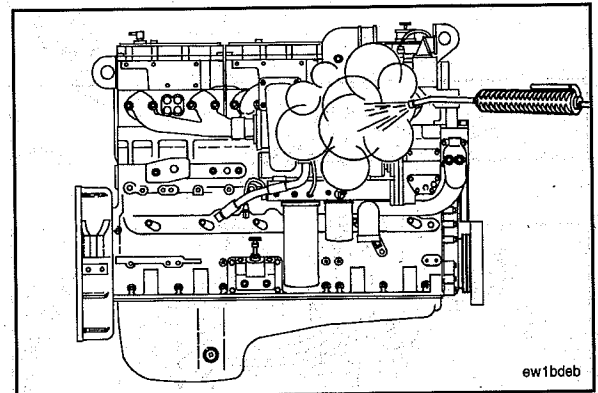

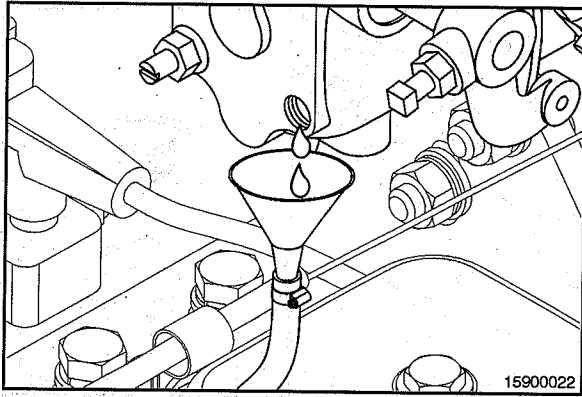

Governor Oil Drain



Some state and federal agencies have determined that used engine oil can be carcinogenic and cause reproductive toxicity. Avoid inhalation of vapors, ingestion, and prolonged contact with used engine oil. Dispose of the used oil in accordance with local environmental regulations.



The engine must shut down and be level when draining the governor oil.



To reduce the possibility of personal injury, avoid direct contact of hot oil with your skin.

Remove the pipe plug from the base of the governor. Drain the governor oil into a container for disposal.

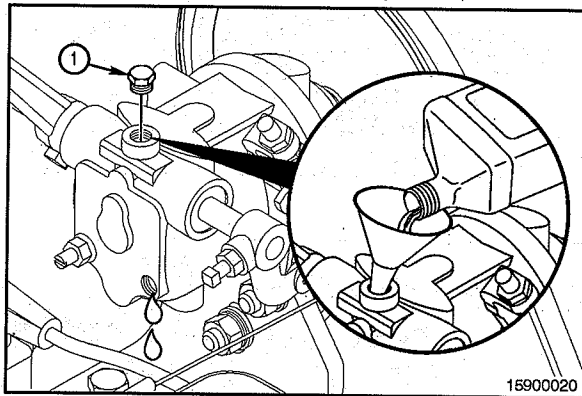

Fill

Remove the pipe plug (1) and slowly add oil to the governor until oil is coming out of the drain plug opening.

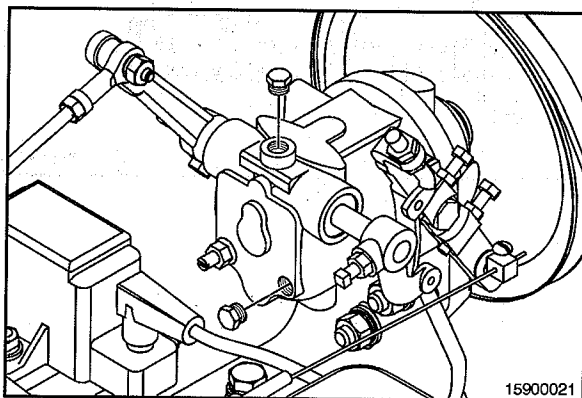

Install the drain plug, pipe plug and tighten.

Torque Value:

Pipe and Drain 25 N•m [18 ft-lb]

Plug



Wipe any oil residue from the governor drain plug.

Overhead Set Preparatory Steps

Remove valve cover.
Refer to Procedure 003-011.

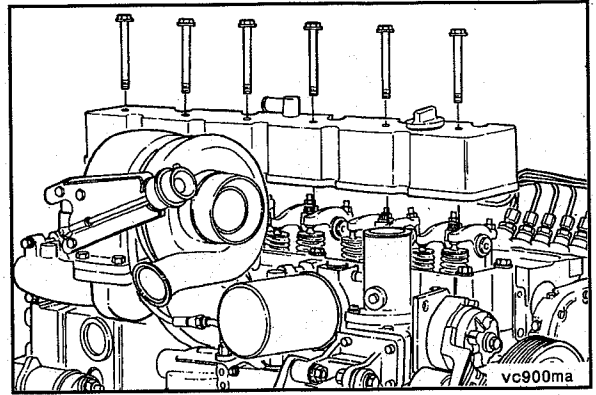

Remove number 1 spark plug.
Refer to Procedure 013-016.

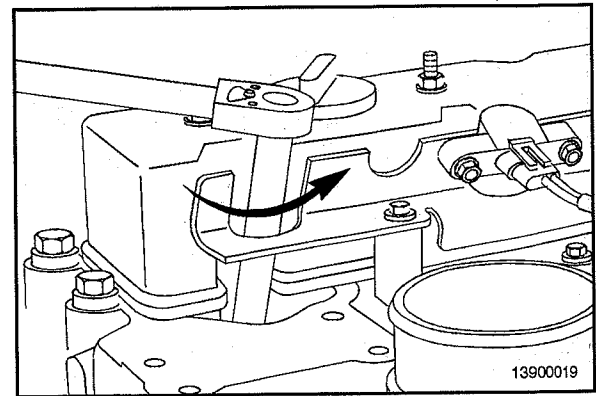

To locate top dead center (TDC) for cylinder number 1 insert a small wooden dowel into the number 1 spark plug hole and rotate the engine until the engine is at top dead center (TDC).

The engine is at top dead center (TDC) if both number 1 rocker levers are loose.

If both rocker levers are **not** loose, rotate the crankshaft 360 degrees.

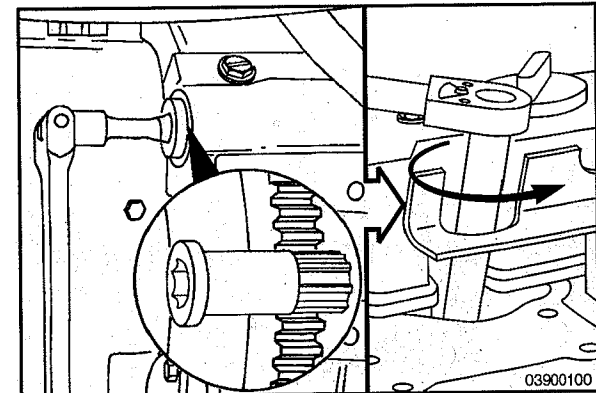

Adjust

Feeler Gauge

The clearance is correct when some resistance is felt when the feeler gauge is slipped between the valve stem and the rocker lever.

Intake Clearance: 0.305 mm [0.012 in]

Exhaust Clearance: 0.610 mm [0.024 in]

Check and set valves with engine cold - below 60 °C [140° F].

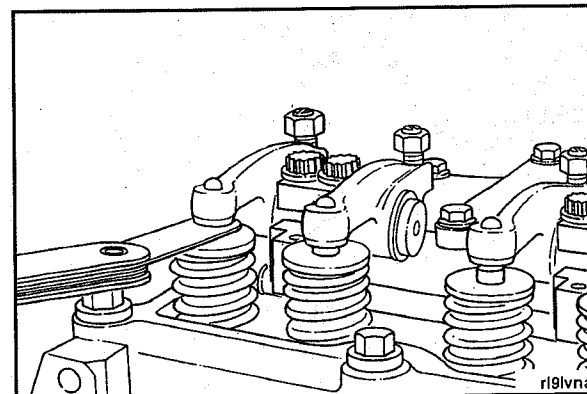

Section 6 - Maintenance Procedures at 1500 Hours or 1 Year

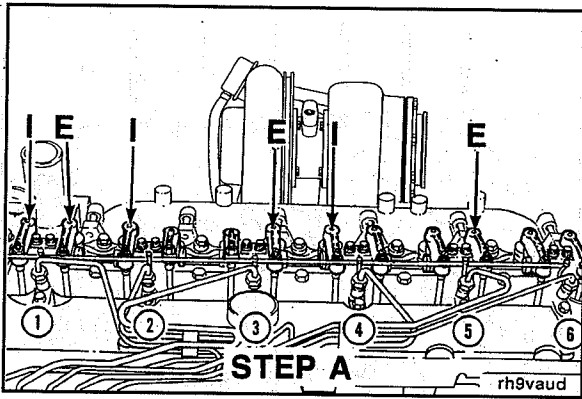

Check and adjust the valves indicated for STEP A (I = intake; E = exhaust).



After tightening the rocker lever locknut, check the valve clearance to make sure the valve clearance has **not** changed.

Torque Value: 24 N•m [212 in-lb]

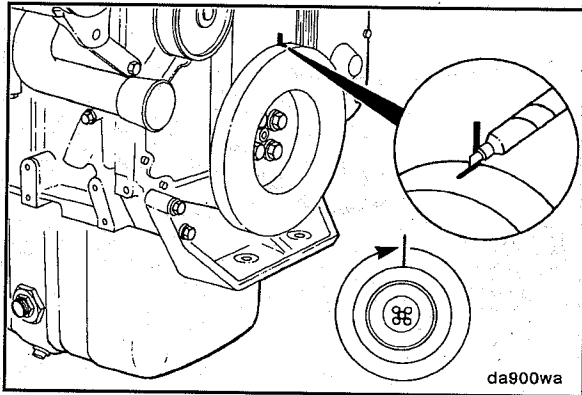

Mark the vibration damper and rotate the crankshaft 360 degrees.

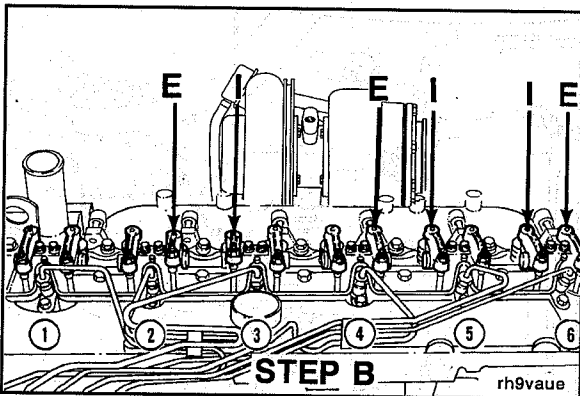

Set the valves indicated for Step B.

After tightening the rocker lever locknut, check the valve clearance to make sure the valve clearance has **not** changed.

Torque Value: 24 N•m [212 in-lb]

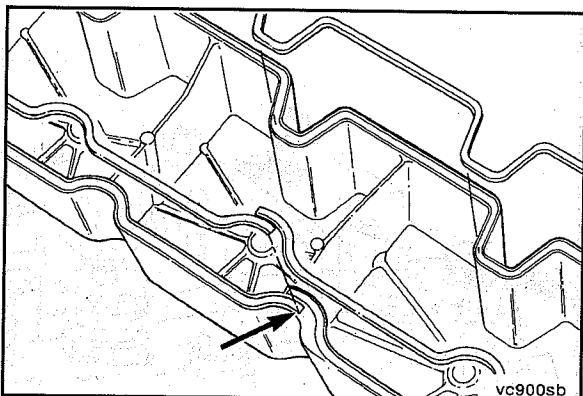

Finishing Steps

If the seal is **not** damaged, it can be used again. If the seal is damaged, install a new seal.

Install the rubber seal into the groove in the valve cover. Start the installation at the overlap area shown in the illustration. Do **not** stretch the rubber seal.

If the seal has more overlap than shown in the illustration, trim the length to provide the correct overlap.

Install new sealing o-rings on the capscrews.
 Refer to Procedure 003-011.

Install the valve cover.

Torque Value: 24 N•m [212 in-lb]

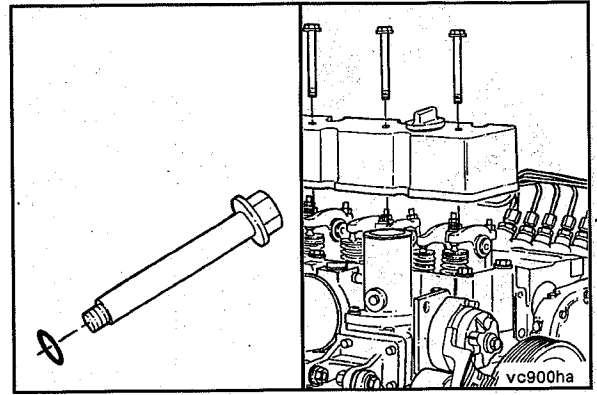

Install the spark plug.
 Refer to Procedure 013-016.

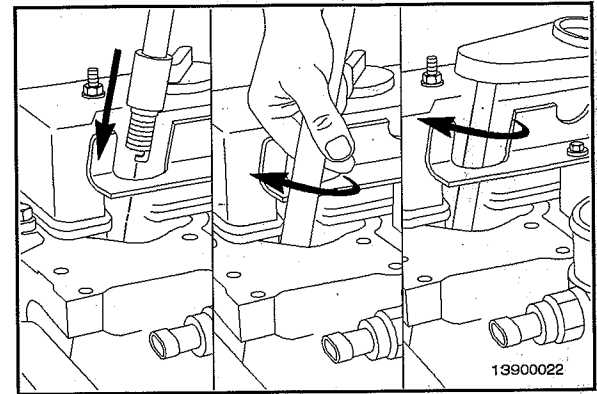

Ignition Timing Adjust



Check that the voltage of the timing light has the same voltage as the battery source, damage to the timing light can occur.

Connect the timing light induction pick up clamp around the spark plug secondary wire for number 1 cylinder and connect the leads to the battery.

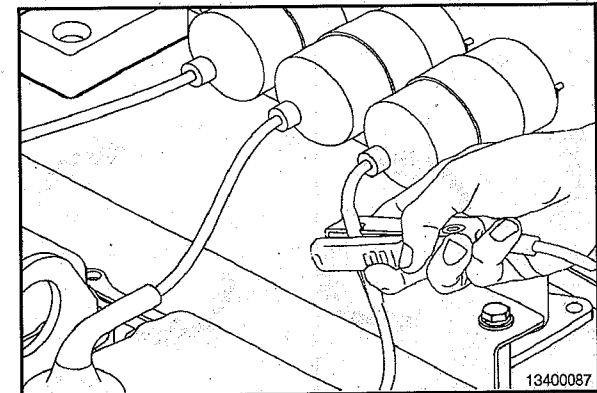

Start the engine and allow it to reach 60°C [140°F] coolant temperature.

Once up to temperature, set the rpm to rated speed.

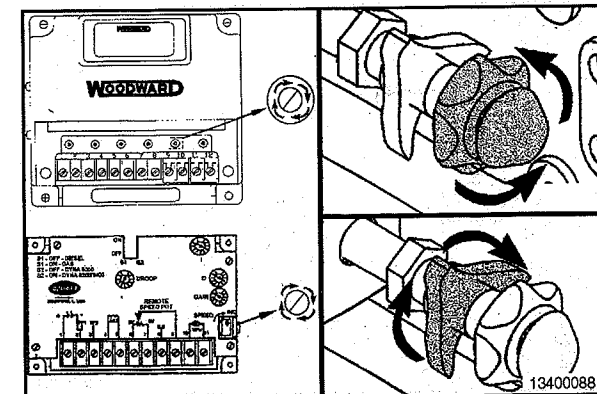

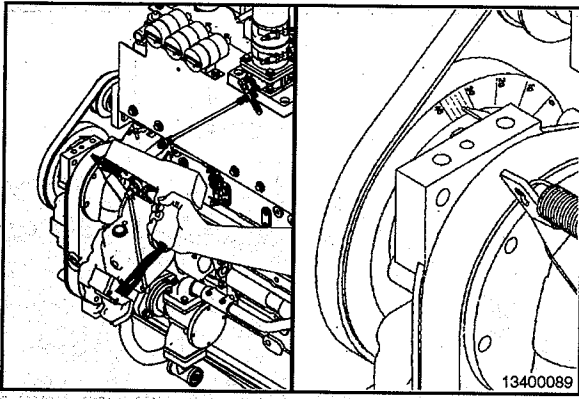

Point the timing light toward the ignition timing marks on the accessory drive pulley. The timing mark will be illuminated showing the number of degrees before top dead center (BTDC) that the spark is occurring on the cylinder which the timing light is connected to.

Compare the measured timing to the specification for the engine.

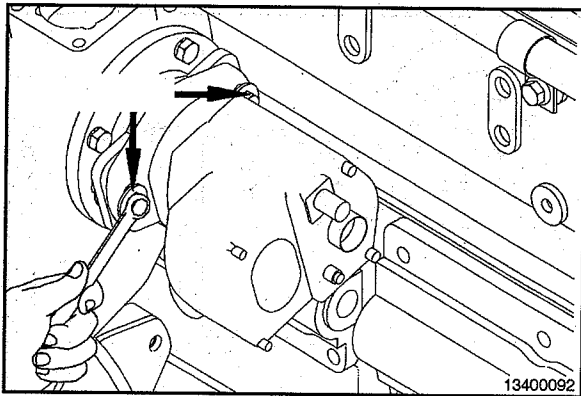

Electro-Mechanical Type

If the timing requires adjustment, loosen but do not remove the two mounting capscrews on the ignition generator so that the generator can be rotated.

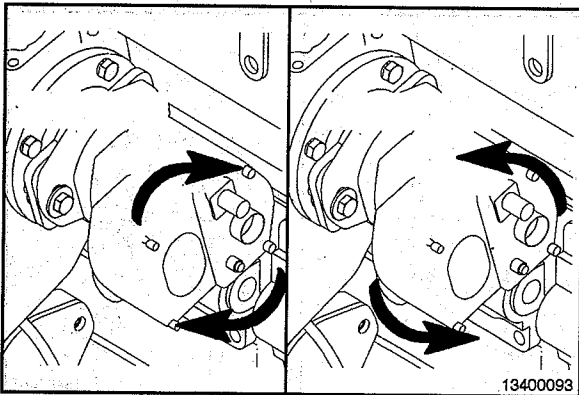

To advance the timing, rotate the ignition generator **clockwise** from the rear of the engine.

To retard the timing, rotate the ignition generator **counterclockwise** from the rear of the engine.

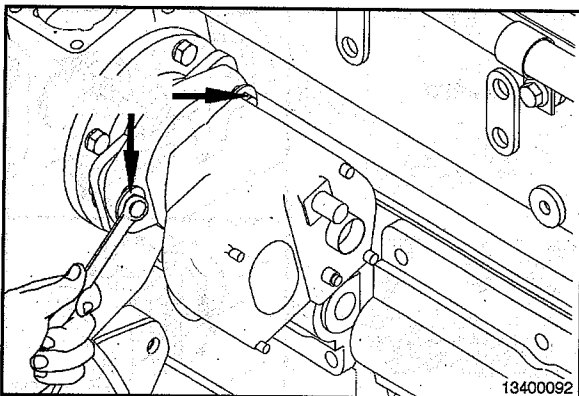

Once the required timing is achieved, tighten the two mounting capscrews.

Torque Value:

Electro-Mechanical Ignition Generator Capscrews

47 N•m [35 ft-lb]

Electronic Type

If the ignition timing requires adjustment, use the timing switch (1) located under the plastic white cap at one end of the ignition generator.

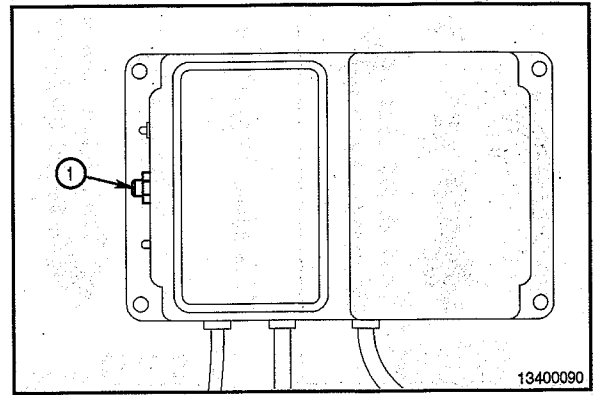

⚠ CAUTION ⚠

To reduce the possibility of shutting down or damage to the engine, do not switch from position 7 to 0 or 0 to 7 while the engine is running.

NOTE: Switch position 7 gives the most advanced timing, position 0 is full retard timing.

Turn the timing switch one position at a time while observing the timing marks with the timing light until the desired timing is obtained.

To advance the timing, rotate the switch **clockwise**.

To retard the timing, rotate the switch **counterclockwise**.

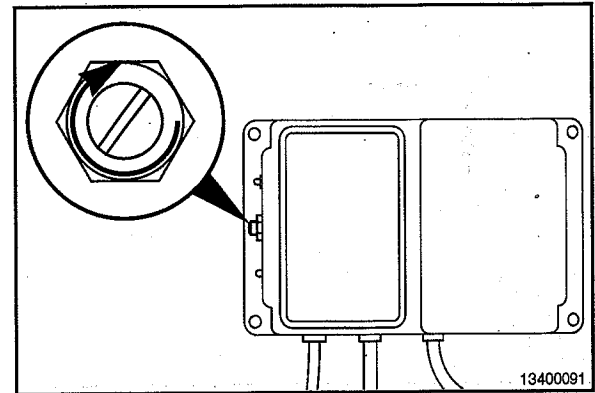

Air/Fuel Mixer

General Information

The proper adjustment of the air/fuel mixer has a direct relationship with the exhaust oxygen (O_2) content.

Exhaust oxygen (O_2) is an indication of the air/fuel ratio. A low exhaust oxygen (O_2) reading indicates a rich air/fuel ratio while a high exhaust oxygen (O_2) indicates a lean condition.

The exhaust oxygen (O_2) is measured by taking a sample of the exhaust gas after the turbocharger usually at a fitting in the exhaust stack.

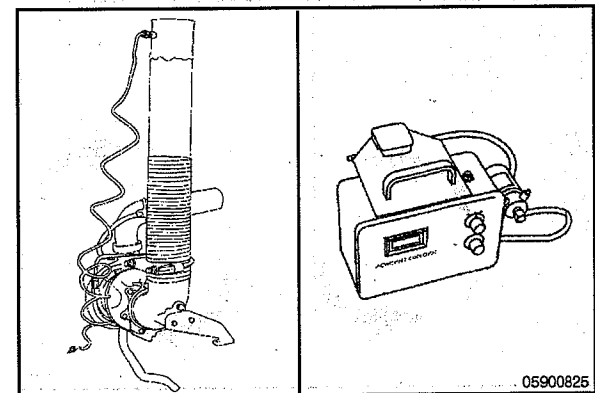

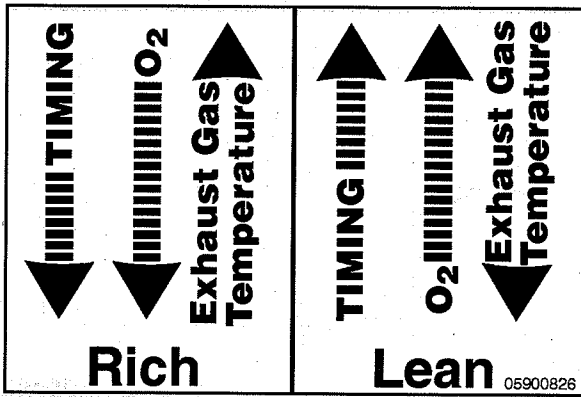

CAUTION

Engines using a Holset® turbocharger must not exceed 732°C [1350°F] turbine inlet temperature or damage to the turbocharger will occur. Engines using a Garrett® turbocharger must not exceed 843°C [1550°F] turbine inlet temperature or damage to the turbocharger will occur.

The turbine inlet temperature is the temperature of the exhaust gas taken as it leaves the engine combustion cylinder and prior to entering the turbocharger. The exhaust gas temperature is an indicator of a rich or lean condition.

Engines using a Holset® turbocharger must not exceed 732°C [1350°F] turbine inlet temperature or damage to the turbocharger will occur.

At the rated load and speed of the engine, turbine inlet temperature is affected by ignition timing, exhaust oxygen (O₂) air/fuel ratio, fuel type, fuel quality, altitude, and ambient temperature. The only two of these that are adjustable are timing and exhaust oxygen (O₂).

Both ignition timing and exhaust oxygen (O₂) are inversely related to turbine inlet temperature. When ignition timing is advanced, turbine inlet temperature decreases, and when ignition timing is retarded, turbine inlet temperature increases.

The same is true for exhaust oxygen (O₂). Increasing exhaust oxygen (O₂) indicates a leaner air/fuel mixture and results in decreasing turbine inlet temperature.

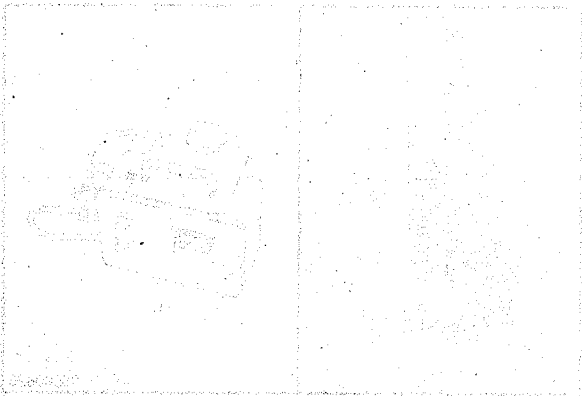
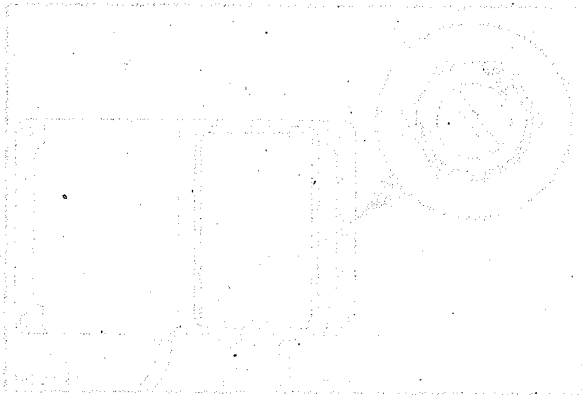

Preparatory Steps

⚠ WARNING ⚠

Natural gas is explosive and flammable. Keep all cigarettes, flames, pilot lights, arcing equipment, and switches out of the work area and areas with shared ventilation to reduce the possibility of severe personal injury or death when working on a natural gas system.

⚠ WARNING ⚠

Natural gas is lighter than air. Check the ceiling of the area where work is to be done for any possible ignition sources.

⚠ WARNING ⚠

Always have proper ventilation when working on a natural gas system.

⚠ WARNING ⚠

Batteries can emit explosive gases. To reduce the possibility of personal injury, always ventilate the compartment before servicing the batteries. To reduce the possibility of arcing, remove the negative (-) battery cable first and attach the negative (-) battery cable last.

⚠ CAUTION ⚠

To reduce the possibility of shock loading of components downstream of the supply valve, opening and closing of the gas supply valve must be done slowly.

- Disconnect the batteries. Refer to Procedure 013-009.
- Slowly close the manual gas supply valve. Refer to Procedure 006-063.

Remove

Remove the fuel supply line connecting the fuel regulator to the air/fuel mixer power valve.

NOTE: Shown is the KTA19GC engine, although different, the procedure remains the same. Depending on the installation instructions for the site, use of hard piping can be used instead of hose connections.

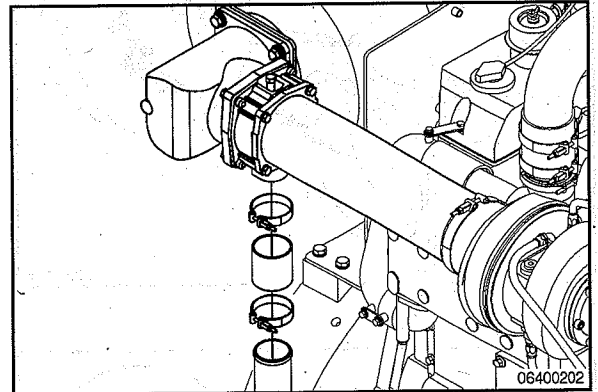
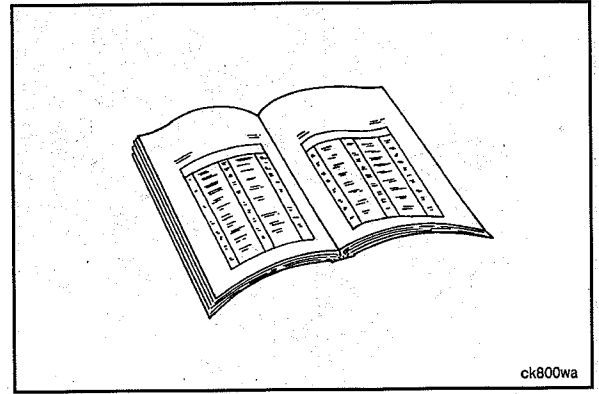

Section 6 - Maintenance Procedures at 1500 Hours or 1 Year

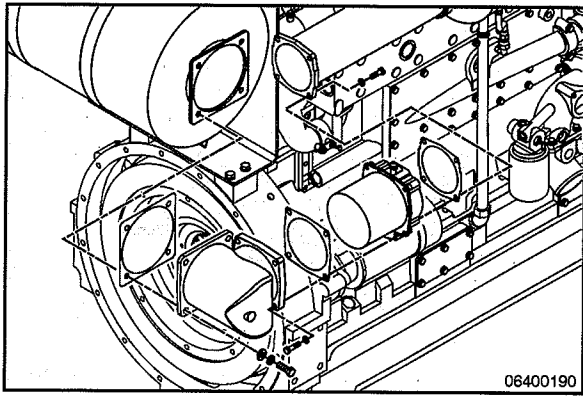

Remove the following capscrews:

- Compressor inlet tube to the air/fuel mixer power valve (7/16 capscrews).
- air/fuel mixer to the air/fuel mixer power valve (7/16 capscrews).
- air/fuel mixer to the air cleaner tube (3/8 capscrews).

NOTE: Shown is the KTA19GC engine. Depending on the installation instructions for the site, use of hose and clamps to connect the air/fuel mixer to the air cleaner tube can be used.

Remove and separate the air/fuel mixer from the air/fuel mixer power valve. Discard the gaskets.

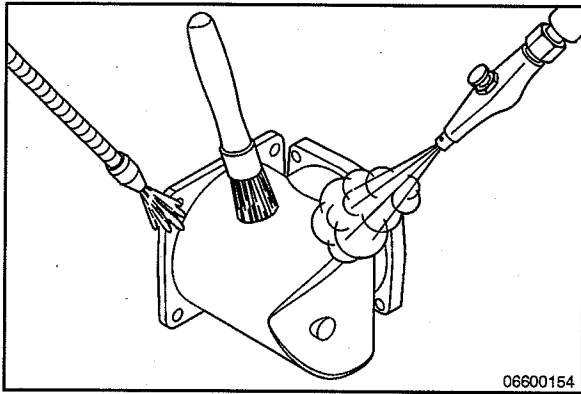

Clean and Inspect for Reuse

▲ WARNING ▲

When using solvents, acids, or alkaline materials for cleaning, follow the manufacturer's recommendations for use. Wear goggles and protective clothing to reduce the possibility of personal injury.

▲ WARNING ▲

Wear appropriate eye and face protection when using compressed air. Flying debris and dirt can cause personal injury.

Using solvent clean the air/mixer valve. Use a soft bristle brush for heavy deposits.

Dry using compressed air.

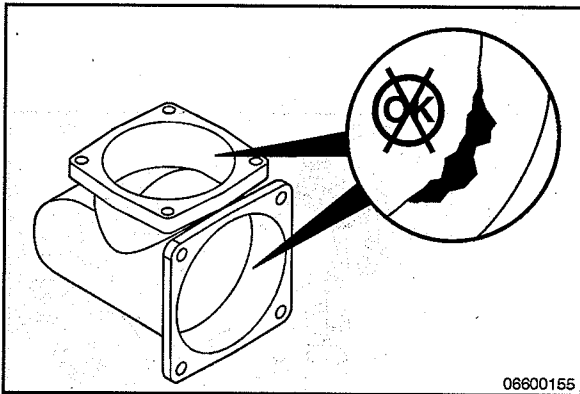

Inspect the air/fuel mixer body for any signs of damage.

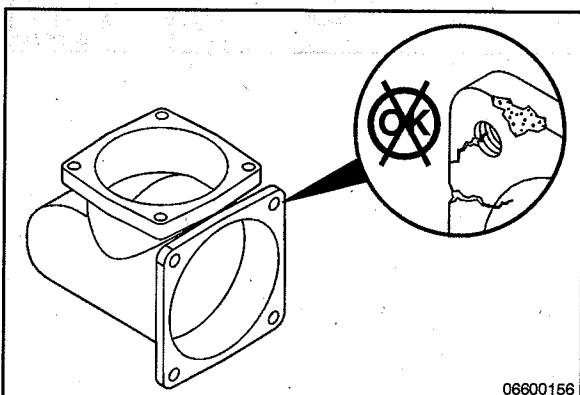

Inspect the flange areas for cracks or damaged capscrew holes.

Install

Using new gaskets, assemble the air/fuel mixer and the air/fuel mixer power valve using four 7/16 capscrews. Hand tighten **only**.

Install the air/fuel mixer onto the engine. Install the following capscrews hand tight:

- Four 7/16 capscrews connecting the compressor inlet tube to the air/fuel mixer power valve.
- Four 3/8 capscrews connecting the air/fuel mixer to the air cleaner tube.

NOTE: Shown is the KTA19GC engine. Depending on the installation instructions for the site, use of hose and clamps to connect the air/fuel mixer to the air cleaner tube can be used.

Tighten the capscrews

Torque Value:
7/16 capscrews 27 N•m [20 ft-lb]

Torque Value:
3/8 capscrews 61 N•m [45 ft-lb]

Install the fuel supply line connecting the fuel regulator to the air/fuel mixer power valve.

NOTE: Shown is the KTA19GC engine. Depending on the installation instructions for the site, use of hard piping can be used instead of hose connections.

Torque Value:
Hose clamps 7 N•m [62 in-lb]

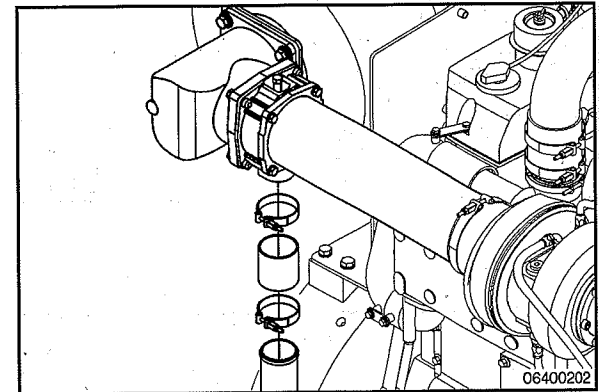
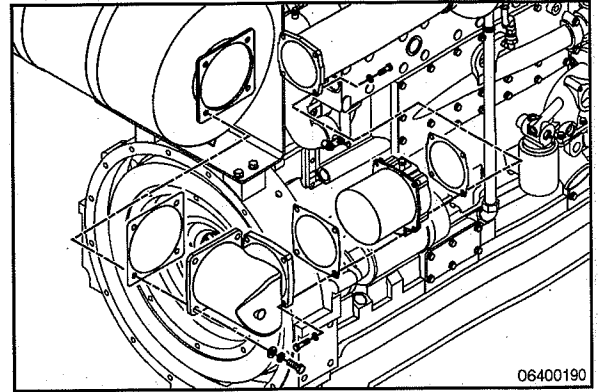

Finishing Steps

▲ WARNING ▲

Batteries can emit explosive gases. To reduce the possibility of personal injury, always ventilate the compartment before servicing the batteries. To reduce the possibility of arcing, remove the negative (-) battery cable first and attach the negative (-) battery cable last.

▲ CAUTION ▲

To reduce the possibility of shock loading of components downstream of the supply valve, opening and closing of the gas supply valve must be done slowly.

- Slowly open the manual gas supply valve. Refer to Procedure 006-063.
- Connect the batteries. Refer to Procedure 013-009.

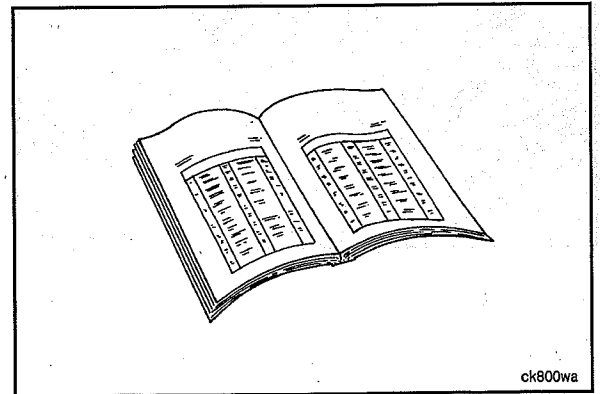

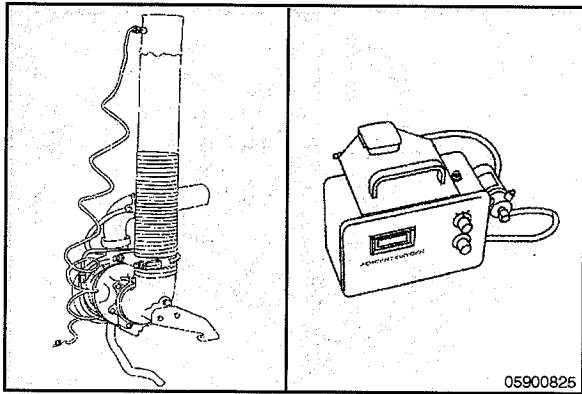

Adjust

Determine the correct exhaust oxygen (O_2) specifications from the Fuel System Operating Specifications and Derates table in Section V of this book.

Install the Exhaust Oxygen (O_2) using an oxygen meter. Refer to the manufacturer's operating instructions.

Start the engine. Refer to Procedure 101-014 (Normal Starting Procedure) in Section 1. Operate the engine until the coolant temperature reaches 60°C [140°F].

Once to operating temperature, raise the engine rpm to rated speed and load.

Measure the Exhaust Oxygen (O_2) using an oxygen meter. Refer to the manufacturer's operating instructions.

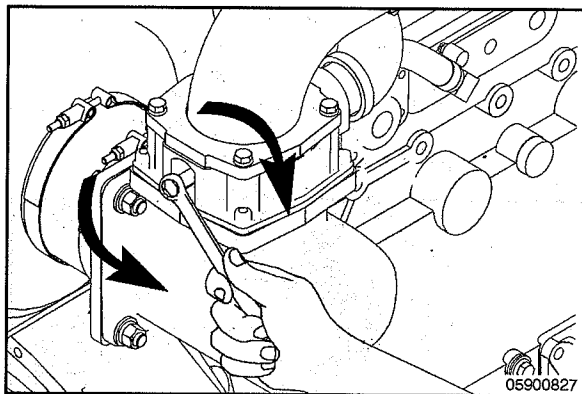

Adjust the exhaust oxygen (O_2) by turning the power valve on the carburetor.

Turn the valve **clockwise** to lean the air/fuel mixture which will cause the exhaust oxygen (O_2) reading to increase.

Turn the valve **counterclockwise** to richen the air/fuel mixture which will cause the exhaust oxygen (O_2) reading to decrease.

Allow adequate time between adjustments for the oxygen meter to react to the new condition. This can take up to 30 seconds.

Adjustment is complete when the meter displays the correct specifications for 30 seconds at the rated engine conditions.

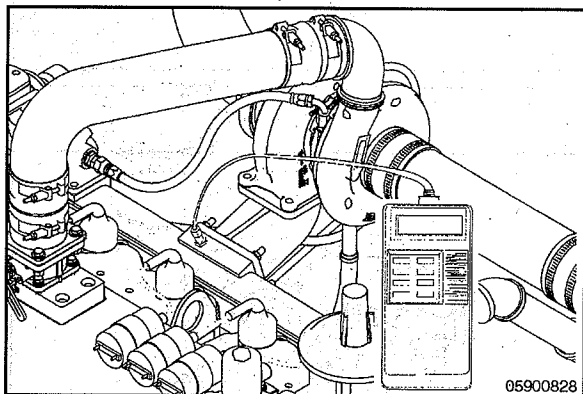

⚠ CAUTION ⚠

Engines using a Holset® turbocharger must not exceed 732°C [1350°F] turbine inlet temperature or damage to the turbocharger will occur. Engines using a Garrett® turbocharger must not exceed 843°C [1550°F] turbine inlet temperature or damage to the turbocharger will occur.

Measure the turbine inlet temperature.

It will be necessary to adjust (advance) the ignition timing to reduce the turbine inlet temperature. Refer to Ignition Timing, Procedure 013-042.

Fuel Filter, NG

Preparatory Steps

Close the manual shut off valve.

The shutoff valve and filter is located outside the module or building in which the engine is located.

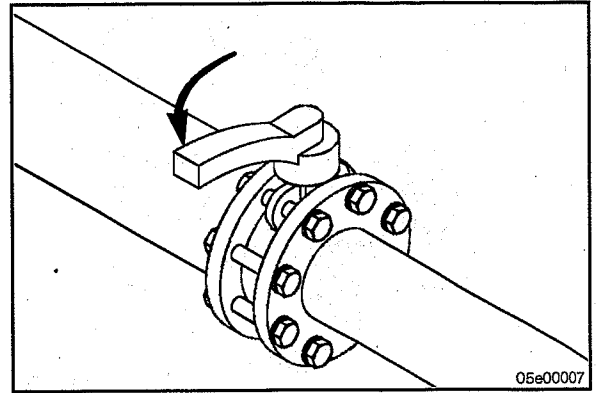

Remove

▲ WARNING ▲

Natural gas is explosive and flammable. Keep all cigarettes, flames, pilot lights, arcing equipment, and switches out of the work area and areas sharing ventilation to reduce the possibility of personal injury or death when working on a natural gas system.

▲ WARNING ▲

Natural gas is lighter than air. Check the ceiling in the area where work is to be done for any possible ignition source.

▲ WARNING ▲

Always have proper ventilation when working on a natural gas system.

Loosen the capscrews to the cover of the filter and allow the gas pressure, 21 kPa [3 psi], to vent.

Remove the filter cover (1) and element (2). Discard the filter o-ring (3).

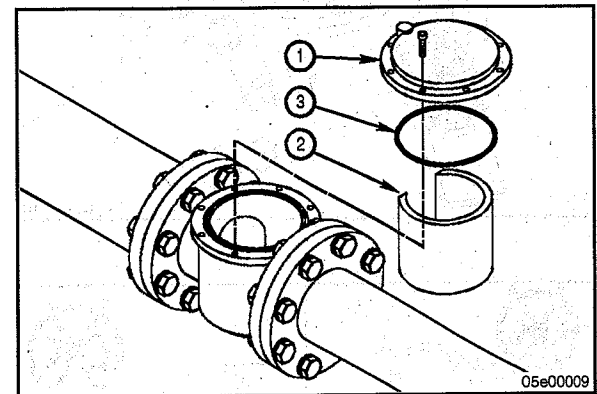
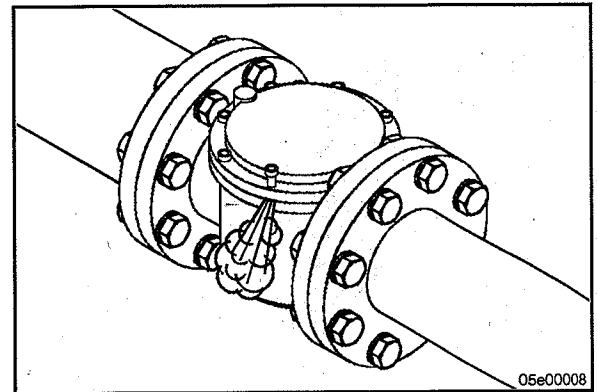

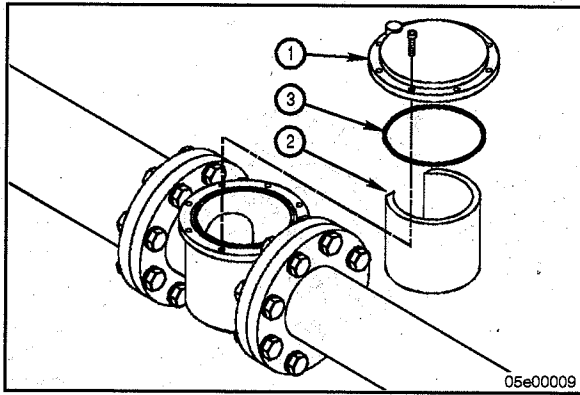

Install

Install a new filter element (2) and replace the filter cover (2) using a new o-ring seal (3).



Tighten the capscrows.

Torque Value: 30 N•m [25 ft-lb]

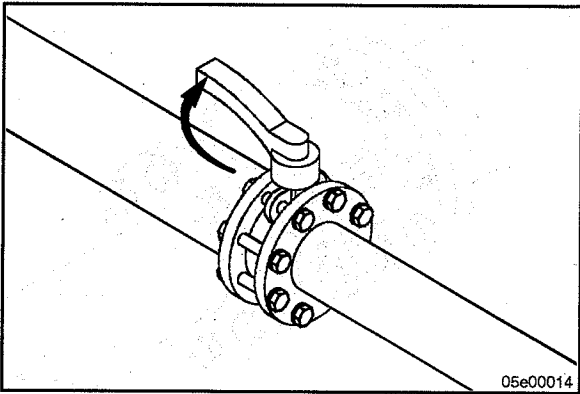

Finishing Steps

Slowly open the manual supply valve.

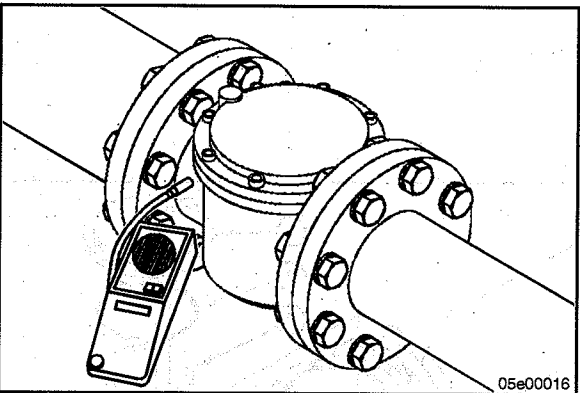

Check the filter housing for gas leaks using a gas detector. If a leak is detected, repair the leak and check again.

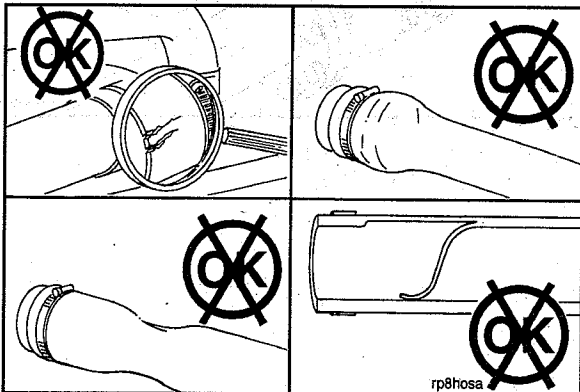

Radiator Hoses

Maintenance Check

Check all hoses for cracks, cuts, or collapsing.

NOTE: The silicone engine coolant hose will exhibit swelling due to the elasticity of the hose.

Air Cleaner Element, Paper Type General Information

The illustrations in this section show typical dry type air cleaner parts. The particular engine parts can vary.

Replace the element if the inlet restriction or vacuum at full power is found to exceed 3.5 kPa [15 in H₂O]. Changing filters or breaking the seal on the intake system more than necessary will result in excess dirt in the engine and **must** be avoided.

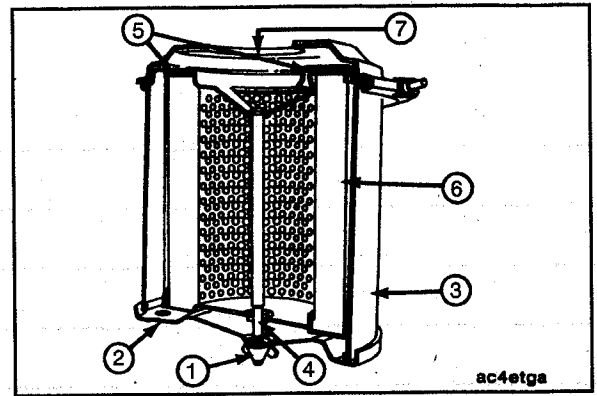

⚠CAUTION⚠

Holes, loose end seals, dented sealing surfaces and other forms of damage render the cleaner inoperative and require immediate element replacement.

Cummins Inc. does not recommend cleaning paper type air cleaner elements.

Elements that have been cleaned will clog and air flow to the engine will be restricted.

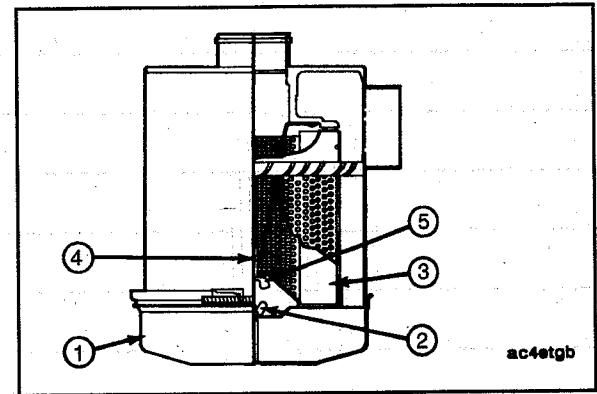

⚠CAUTION⚠

Pull the cover and the element straight out when removing them from the housing to reduce the possibility of damage to the element.

Remove the wing nut (1) that secures the bottom cover (2) to the cleaner housing (3). Remove the cover.

Pull the element (6) down from the center bolt (4).

Remove the gasket (5) from the outlet end (7) of the housing.

Inspect the gasket. Replace the gasket if necessary.

Assemble the bottom cover to the cleaner housing.

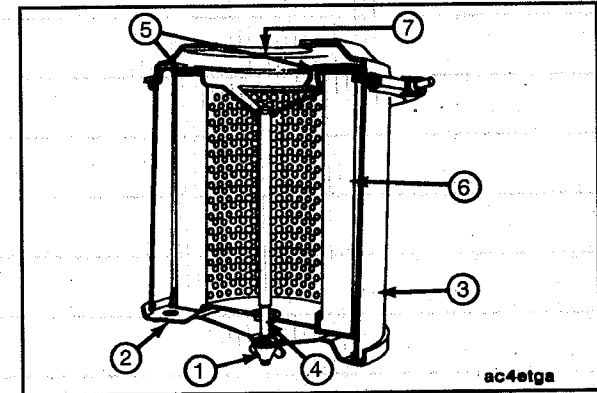

Notes

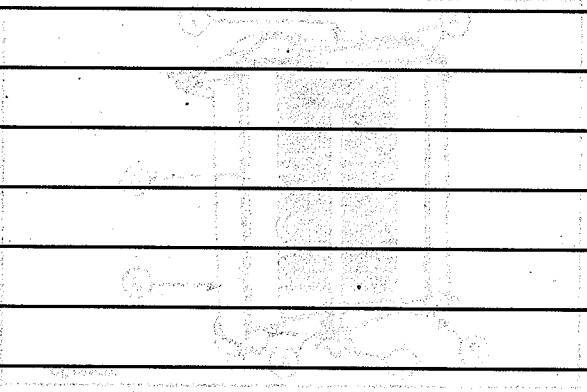
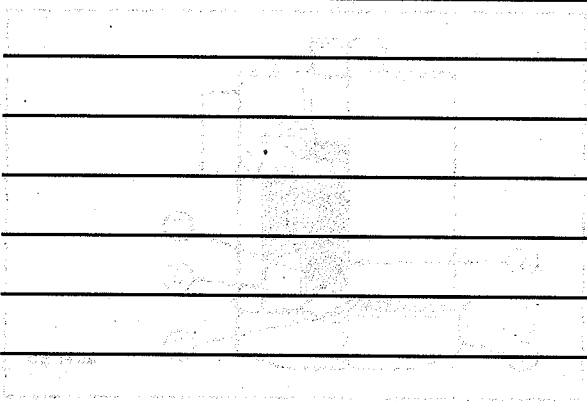
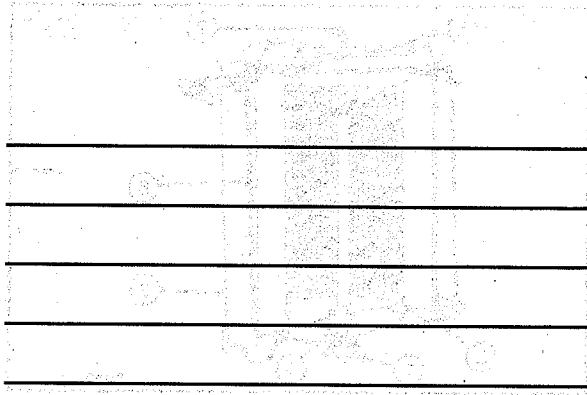

The air cleaner element is located in the engine compartment. To remove the element, turn the top cover counter-clockwise until it is loose. Then lift the element out of the housing. The element should be replaced if it is dirty or damaged.

When the element is removed, inspect it for dirt and damage. If the element is dirty, clean it with a mild detergent and water. If the element is damaged, replace it with a new one. The element should be replaced every 1500 hours or 1 year.

After cleaning or replacing the element, reassemble the air cleaner. Turn the top cover clockwise until it is tight. The air cleaner should be tested for proper operation. The air cleaner should be tested every 1500 hours or 1 year.

Section 7 - Maintenance Procedures at 6000 Hours or 2 Years

Section Contents

	Page
Cooling System	7-5
Drain	7-5
Marine Applications.....	7-5
Industrial Applications.....	7-5
Fill	7-9
Marine Applications.....	7-9
Industrial Applications.....	7-9
Flush	7-6
Marine Applications.....	7-6
Industrial Applications.....	7-8
Drive Belt, Cooling Fan	7-10
Inspect for Reuse.....	7-11
Install.....	7-11
Remove.....	7-10
Fan Hub, Belt Driven	7-2
Maintenance Check.....	7-2
Maintenance Procedures - Overview	7-1
General Information.....	7-1
Turbocharger	7-3
Maintenance Check.....	7-3
Vibration Damper, Rubber	7-2
Inspect.....	7-2
Vibration Damper, Viscous	7-3
Inspect.....	7-3
Water Pump	7-1
Maintenance Check.....	7-1

This Page Left Intentionally Blank

Maintenance Procedures - Overview

General Information

All maintenance checks and inspections listed in previous maintenance intervals **must** also be performed at this time, in addition to those listed under this maintenance interval.

Water Pump Maintenance Check

Check the water pump body for indications of water leakage at the weep hole.

A chemical streak or chemical buildup at the weep hole is **not** justification for water pump replacement. If a steady flow of coolant or oil is observed, replace the water pump with a new or rebuilt unit.

Refer to a Cummins Authorized Repair Location.

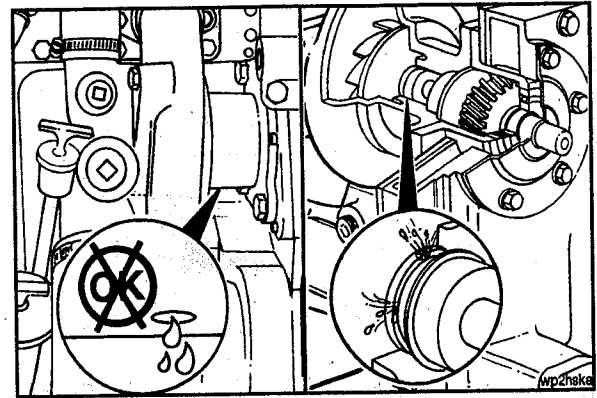

Make sure the weep hole is open. A small screwdriver or similar tool can be used to remove any debris.

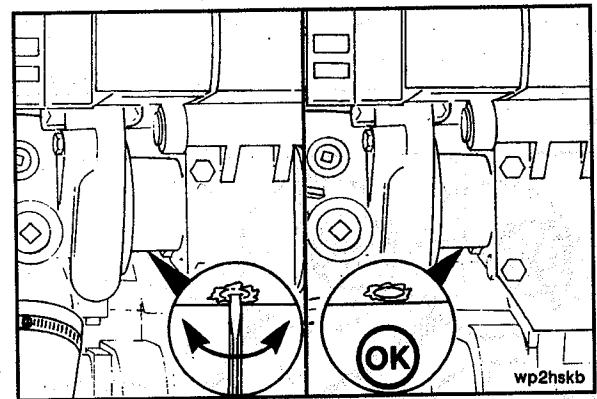

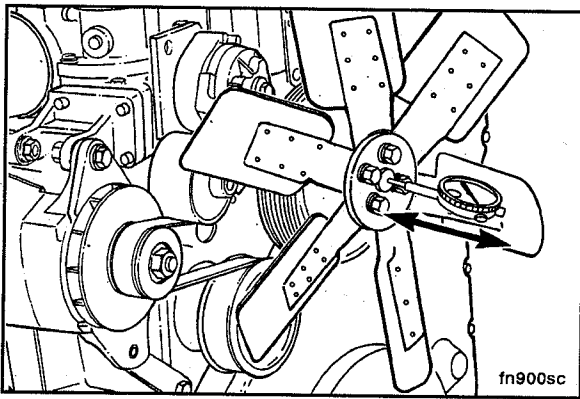

Fan Hub, Belt Driven Maintenance Check

Remove the fan drive belt.

Inspect the fan hub for the following:

- Freedom of rotation
- Cracks
- Grease seal leakage.

Measure the fan hub end clearance.

Fan Hub End Clearance		
mm		in
0.15	MAX	0.006

Replace or rebuild the fan hub if the clearance does not meet this specification. Refer to a Cummins Authorized Repair Location.

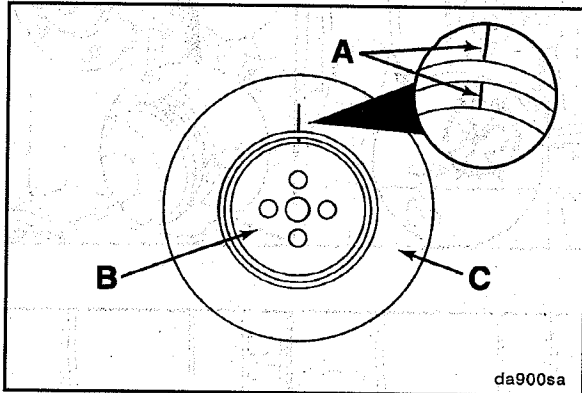

Vibration Damper, Rubber Inspect

Check the index lines (A) in the vibration damper hub (B) and the inertia member (C). If the lines are more than 1.59 mm [1/16 in] out of alignment, replace the vibration damper.

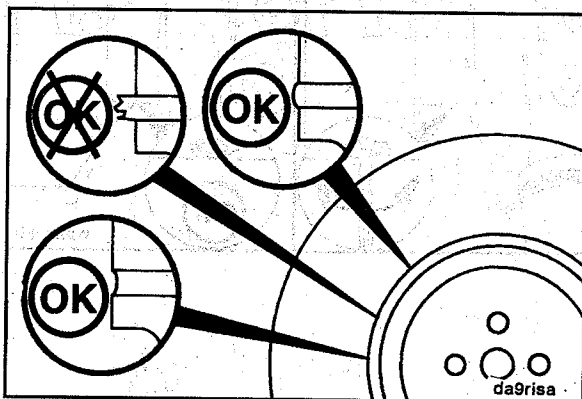

Inspect the rubber member for deterioration. If pieces of rubber are missing or if the elastic member is more than 3.18 mm [1/8 in] below the metal surface, replace the damper.

Look for forward movement on the damper ring on the hub. Replace the vibration damper if any movement is detected.

For vibration damper location, refer to Engine Diagrams in Engine Identification (Section E).

Vibration Damper, Viscous Inspect

⚠CAUTION⚠

The silicone fluid in the vibration damper will become solid after extended service and will make the damper inoperative. An inoperative vibration damper can cause major engine or drivetrain failures.

Check the vibration damper for evidence of fluid loss, dents, and wobble. Inspect the vibration damper thickness for any deformation or raising of the damper cover plate.

If any of these conditions are identified, contact your local Cummins Authorized Repair Location to replace the vibration damper.

Viscous dampers have a limited life. The maximum damper life specifications are located in Maintenance Specifications (Section V).

For vibration damper location, refer to Engine Diagrams in Engine Identification (Section E).

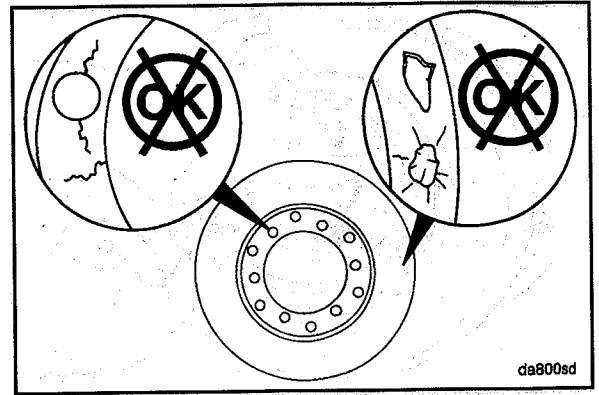

Turbocharger Maintenance Check

Remove the air intake and exhaust piping from the turbocharger.

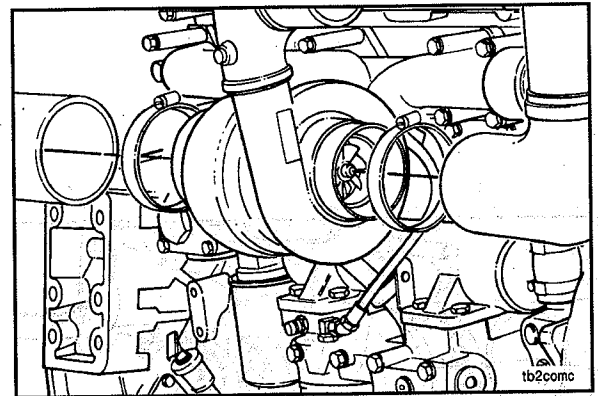

Inspect for any signs of rubbing with the compressor or turbine wheel to the compressor cover or turbine housing.

If signs of rubbing are present, replace the turbocharger. Contact a Cummins Authorized Repair Facility.

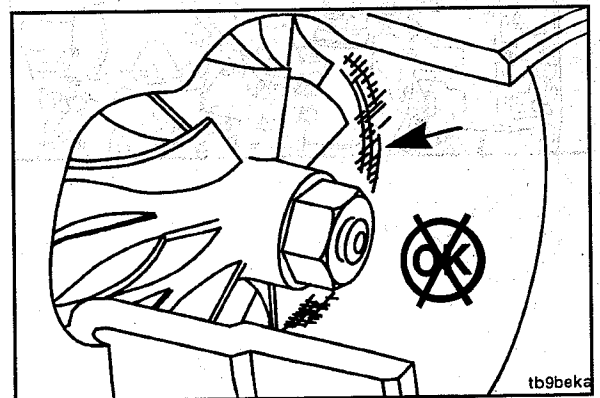

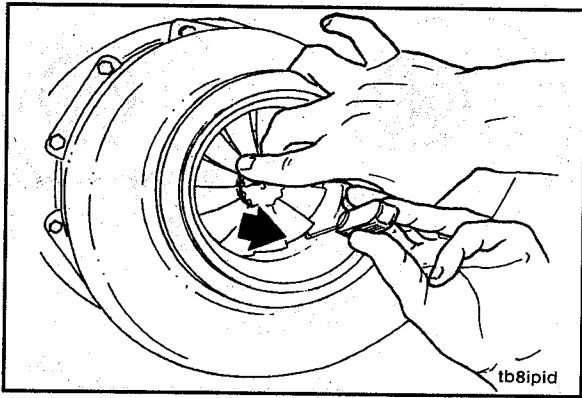

Using light finger pressure, push the compressor wheel radially toward the compressor cover.

If the compressor wheel touches the compressor cover, the turbocharger may have excessive bearing clearance.

Contact a Cummins Authorized Repair Facility.

If there is still a concern, contact a Cummins Authorized Repair Facility to perform radial and axial measurements of the turbocharger.

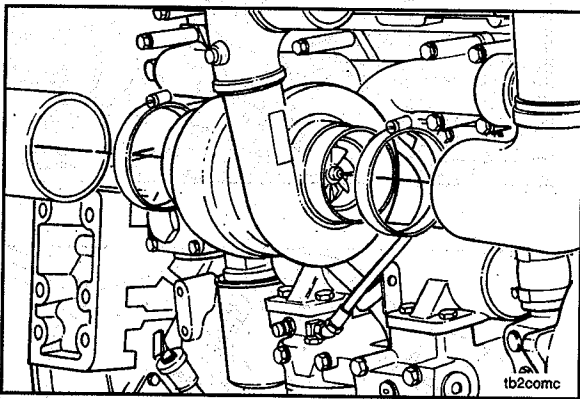

Install the air intake and exhaust piping to the turbocharger.

Cooling System

Drain

Marine Applications

▲ WARNING ▲

Do not remove the pressure cap from a hot engine. Wait until the coolant temperature is below 50°C [120°F] before removing the pressure cap. Heated coolant spray or steam can cause personal injury.

▲ WARNING ▲

Coolant is toxic. Keep away from children and pets. If not reused, dispose of in accordance with local environmental regulations.

- Avoid excessive contact, and wash thoroughly after contact.
- Keep out of reach of children.

Drain the engine cooling system by opening the drain valve on the engine oil cooler (exhaust side of engine). A drain pan with a capacity of 31.7 liters (8 gal) will be adequate in most installations. Remove the pressure cap to allow the coolant to drain properly. After the cooling system is completely drained, close the drain valve.

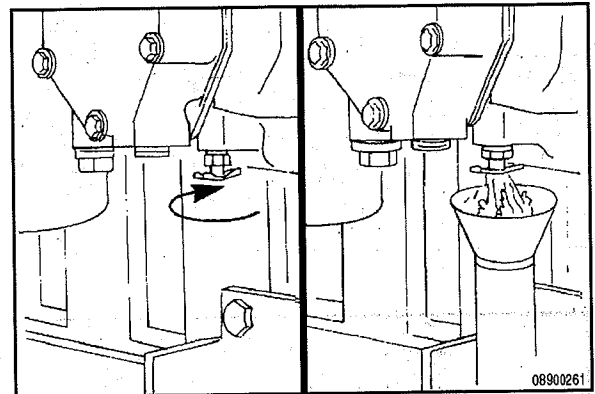
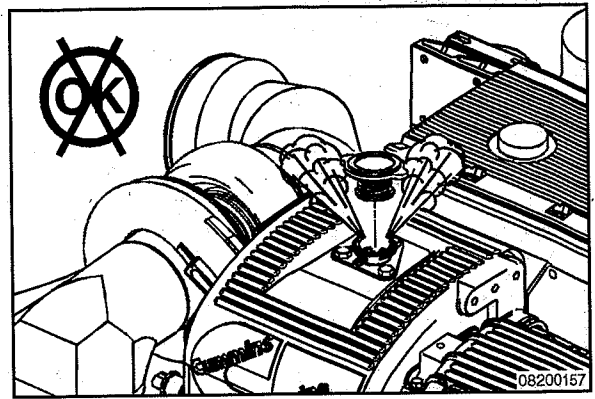

Industrial Applications

▲ WARNING ▲

Do not remove the pressure cap from a hot engine. Wait until the coolant temperature is below 50°C [120°F] before removing the pressure cap. Heated coolant spray or steam can cause personal injury.

▲ WARNING ▲

Coolant is toxic. Keep away from children and pets. If not reused, dispose of in accordance with local environmental regulations.

- Avoid excessive contact, and wash thoroughly after contact.
- Keep out of reach of children.

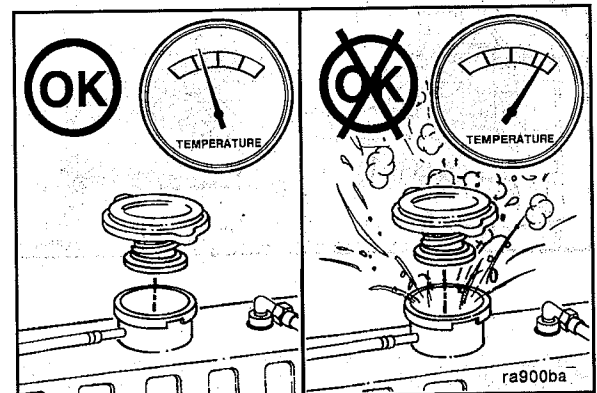

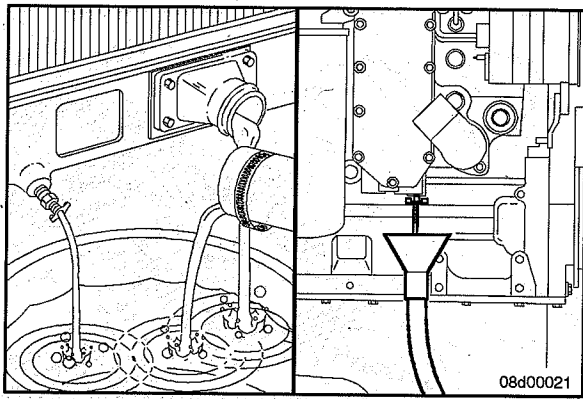

Drain the cooling system by opening the drain valve on the radiator and removing the plug in the bottom of the water inlet hose. A drain pan with a capacity of 19 liters [5 gal] will be adequate for most applications.

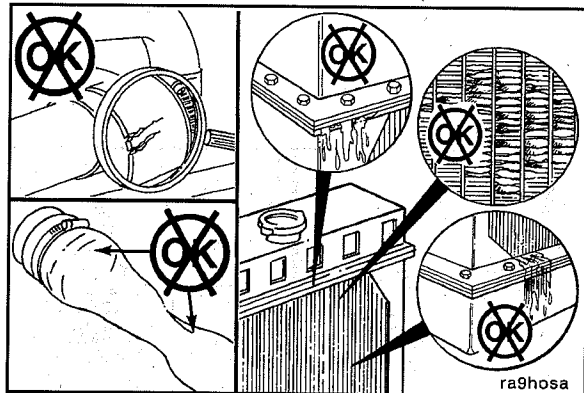

Check for damaged hoses and loose or damaged hose clamps. Replace as required.

Check the radiator for leaks, damage, and buildup of dirt.



Clean and replace as required.



Flush

Marine Applications

RESTORE™ is a heavy-duty cooling system cleaner that removes corrosion products, silica gel, and other deposits. The performance of RESTORE™ is dependent on time, temperature, and concentration levels. An extremely scaled or flow-restricted system, for example, can require higher concentrations of cleaners, higher temperatures, or longer cleaning times or the use of RESTORE Plus™. Up to twice the recommended concentration levels of RESTORE™ can be used safely. RESTORE Plus™ **must** be used **only** at its recommended concentration level. Extremely scaled or fouled systems can require more than one cleaning.

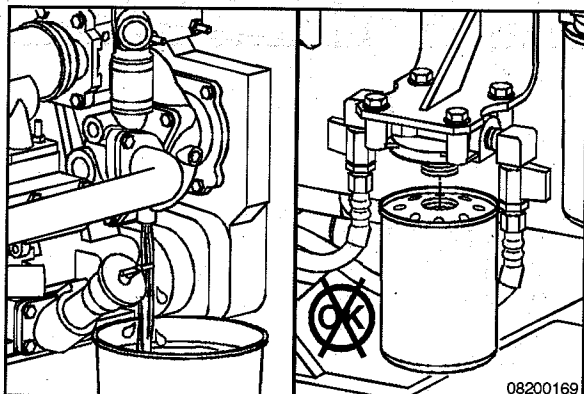

⚠ WARNING ⚠

Coolant is toxic. Keep away from children and pets. If not reused, dispose of in accordance with local environmental regulations.

If not previously done, drain the cooling system. Refer to Cooling System - Drain. Do **not** allow the cooling system to dry out.

Do **not** remove the coolant filter.

CAUTION

Fleetguard® RESTORE™ contains no antifreeze. Do not allow the cooling system to freeze during the cleaning operations.

Immediately add 3.8 liters [1 gal] of Fleetguard® RESTORE™, RESTORE Plus™, or equivalent, for each 38 to 57 liters [10 to 15 gal] of cooling system capacity. Fill the system with clean water.

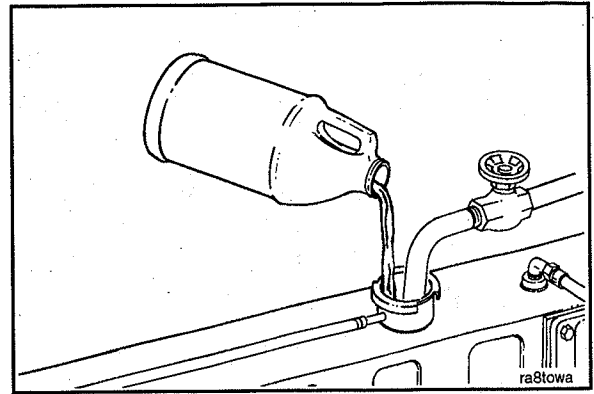

Operate the engine at normal operating temperatures, at least 85°C [185°F], for 1 to 1½ hours.

Shut off the engine, allow to cool to 50°C [122°F] and drain the cooling system.

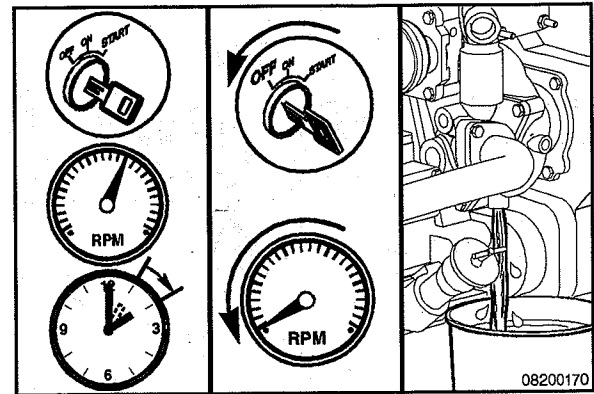

Fill the cooling system with clean water.

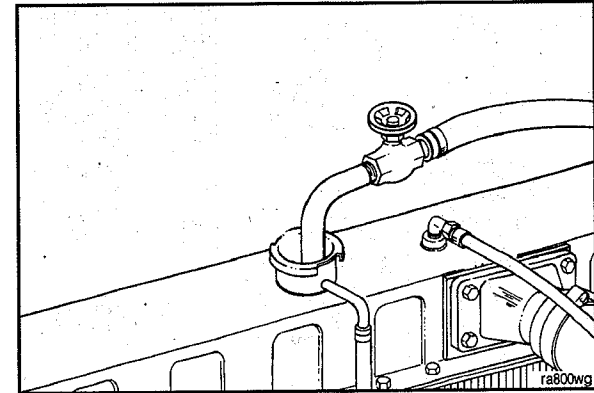

Operate the engine for 5 minutes with the coolant temperature above 85°C [185°F].

Shut off the engine, allow to cool to 50°C [122°F], and drain the cooling system.

If the water being drained is still dirty, the system **must** be flushed again until the water is clean.

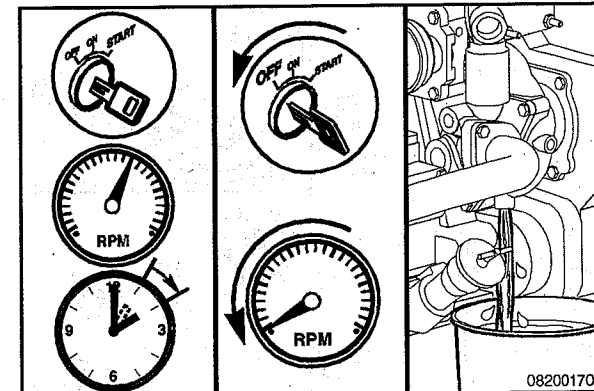

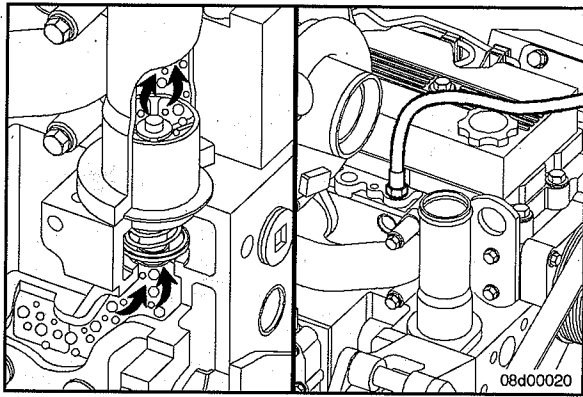

Industrial Applications

⚠ CAUTION ⚠

The system must be filled properly to prevent air locks. During filling, air must be purged from the engine coolant passages. Be sure to open the petcock on the aftercooler for aftercooled engines. Wait 2 to 3 minutes to allow air to be vented; then add mixture to bring the level to the top.

NOTE: Adequate venting is provided for a fill rate of 19 liters [5 gal] per minute.

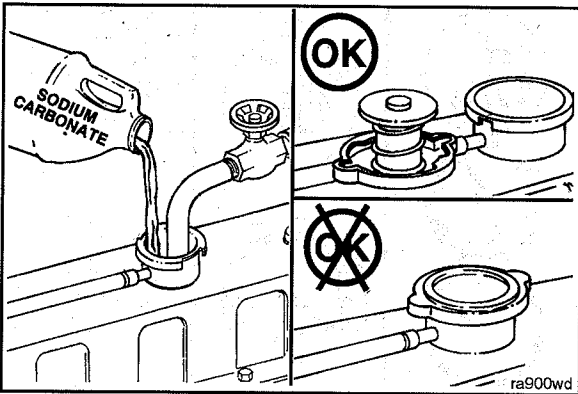

⚠ CAUTION ⚠

Do not install the radiator cap. The engine is to be operated without the cap for this process.

Fill the system with a mixture of sodium carbonate and water (or a commercially available equivalent).

NOTE: Use 0.5 kg [1 lb] of sodium carbonate for every 23 liters [6 gal] of water.

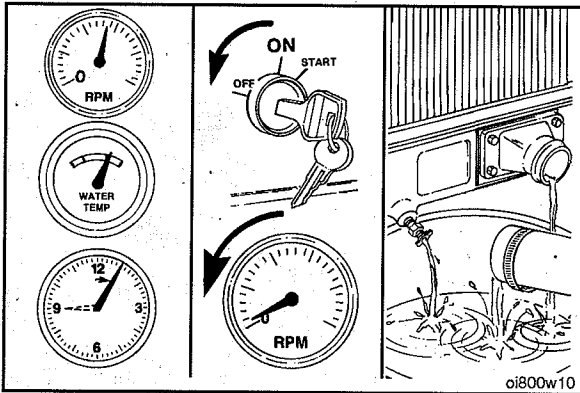

⚠ WARNING ⚠

Coolant is toxic. Keep away from children and pets. If not reused, dispose of in accordance with local environmental regulations.

Operate the engine for 5 minutes with the coolant temperature above 80°C [176°F].

Shut the engine off, and drain the cooling system.

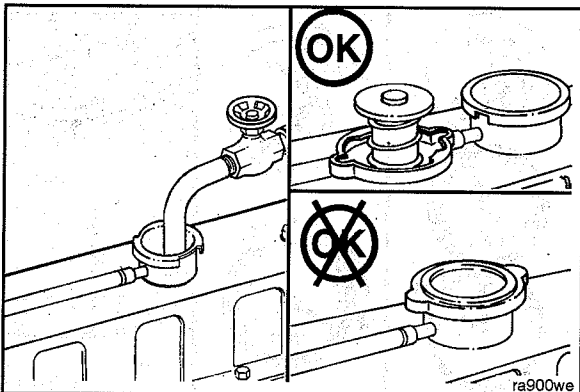

Fill the cooling system with high-quality water.

NOTE: Be sure to vent the engine and aftercooler for complete filling.

NOTE: Do not install the radiator cap or the new coolant filter.

Operate the engine for 5 minutes with the coolant temperature above 80°C [176°F].

Shut the engine off, and drain the cooling system.

NOTE: If the water being drained is still dirty, the system **must** be flushed again until the water is clean.

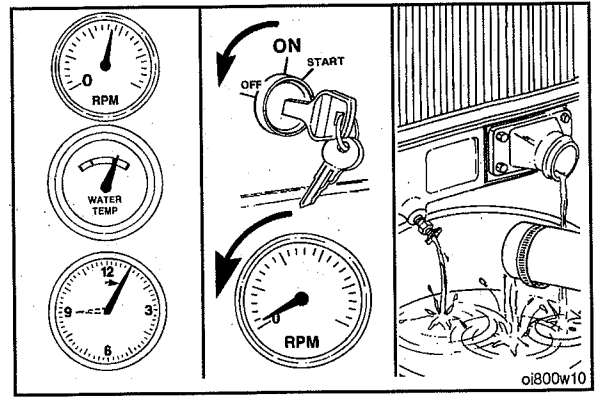

Fill

Marine Applications

Fill the cooling system with fully formulated coolant or a 50/50 mixture of recommended antifreeze, and clean, good-quality water. (Refer to the Coolant Specifications in Section V.)

Install the pressure cap. Operate the engine to 50°C [122°F], and check for coolant leaks.

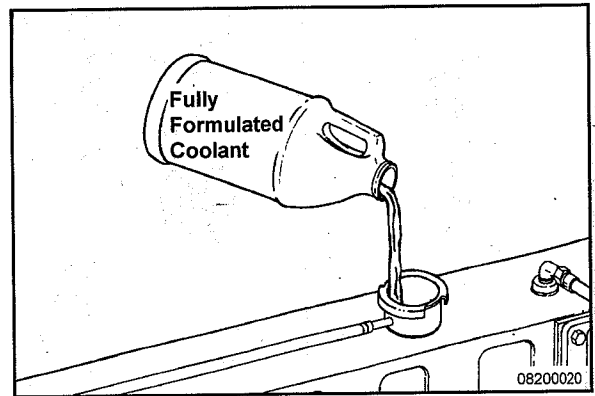

The freeze point protection **must** be checked after coolant is added to the cooling system.

The Fleetguard® refractometer, Part Number C2800, provides a reliable, easy-to-read, and accurate measurement of freeze point protection and antifreeze concentration.

Refer to the OEM's instructions for the correct operation instructions for the Fleetguard® refractometer, Part Number C2800.

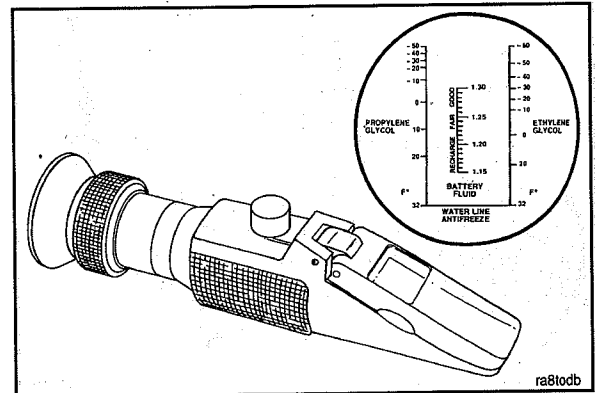
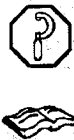

Industrial Applications

CAUTION

The system **must** be filled properly to prevent air locks. During filling, air must be purged from the engine coolant passages. Be sure to open the petcock on the aftercooler for aftercooled engines. Wait 2 to 3 minutes to allow air to be vented; then add mixture to bring the level to the top.

The system is designed to use a specific quantity of coolant. If the coolant level is low, the engine will run hot.

If frequent addition of coolant is necessary, the engine or system has a leak. Find and repair the leak.

The system has a designed fill rate of 19 liters [5 gal] per minute.

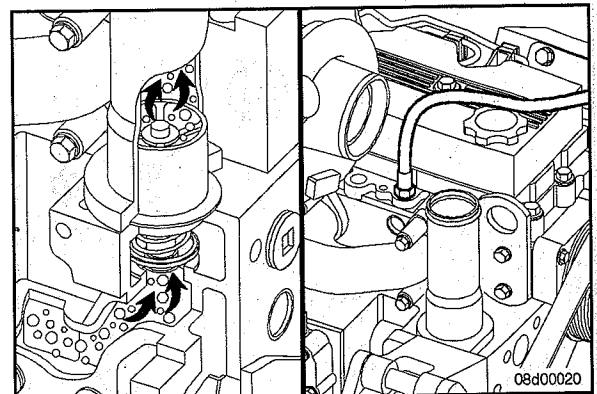

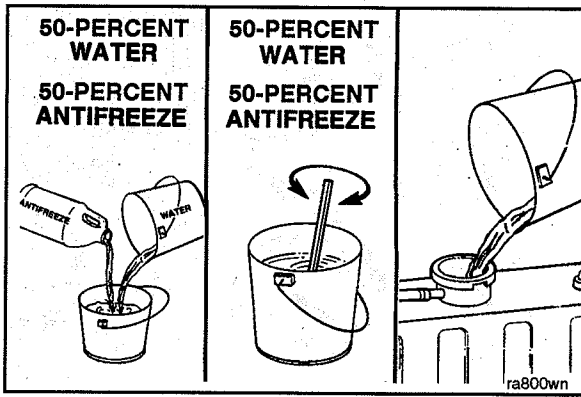

CAUTION

Never use water alone for coolant. This can result in damage from corrosion.

Use a mixture of 50-percent water and 50-percent ethylene glycol or propylene glycol antifreeze to fill the cooling system.

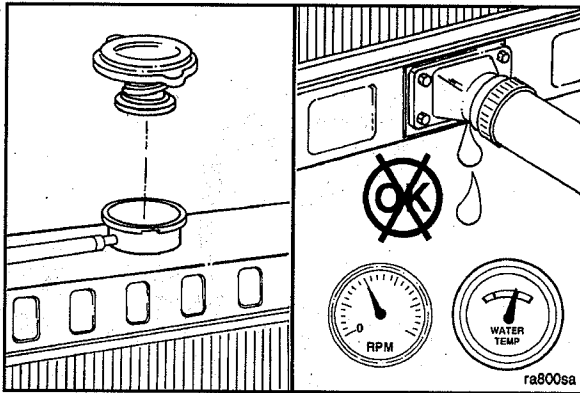

WARNING

Do not remove the pressure cap from a hot engine. Wait until the coolant temperature is below 50°C [120°F] before removing the pressure cap. Heated coolant spray or steam can cause personal injury.

Install the pressure cap. Operate the engine until the coolant reaches a temperature of 80°C [180°F], and check for coolant leaks.

Check the coolant level again to make sure the system is full of coolant or that the coolant level has risen to the hot level in the recovery bottle on the system, if so equipped.

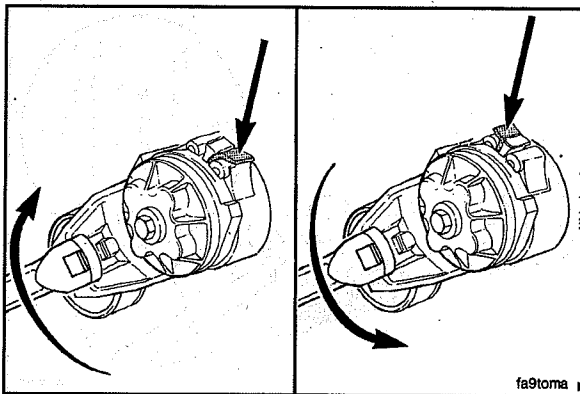

**Drive Belt, Cooling Fan
Remove**



Lift the tensioner to remove the drive belt.

NOTE: The belt tensioner winds in the direction that the spring tang is bent over the tensioner body. To loosen the tension on the belt, rotate the tensioner to wind the spring tighter.

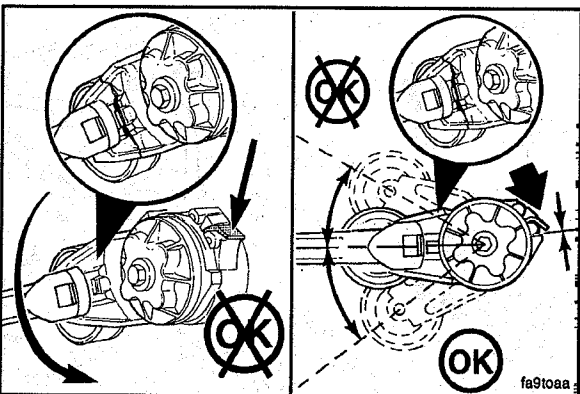

CAUTION

Applying excessive force in the opposite direction of windup or after the tensioner has been wound up to the positive stop can cause the tensioner arm to break.

Inspect for Reuse



Inspect the drive belt for:

- Cracks
- Glazing
- Tears or cuts
- Hardening
- Excessive wear.

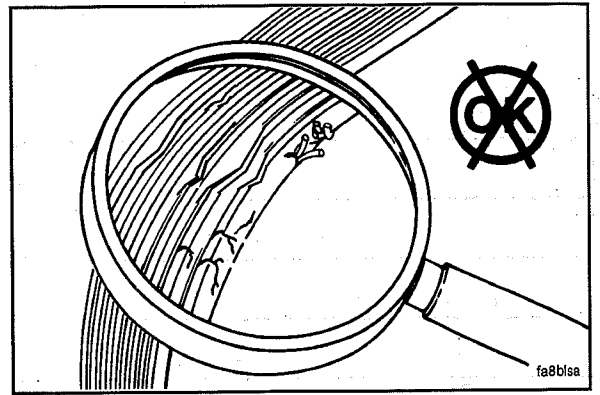

Install



⚠ CAUTION ⚠

The belt tensioner is spring-loaded and must be pivoted away from the drive belt. Pivoting in the wrong direction can result in damage to the belt tensioner.



Lift the tensioner to install the drive belt.

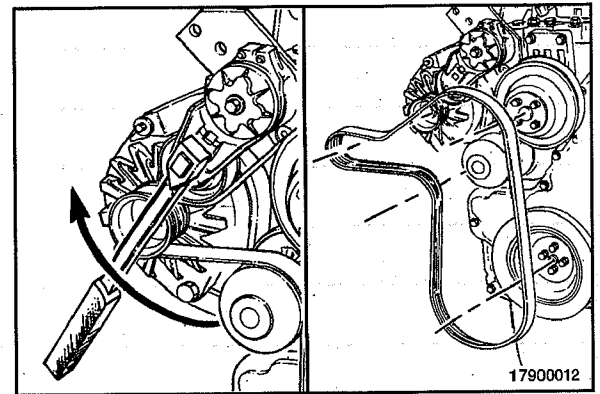

Section A - Adjustment, Repair, and Replacement

Section Contents

	Page
Starting Motor	A-1
Install.....	A-1
Preparatory Steps.....	A-1
Remove.....	A-1

[Faint, illegible text, possibly bleed-through from the reverse side of the page]

This Page Left Intentionally Blank

Starting Motor

Preparatory Steps

- Disconnect the ground cable from the battery terminal.
- Identify each electrical wire with a tag indicating location.

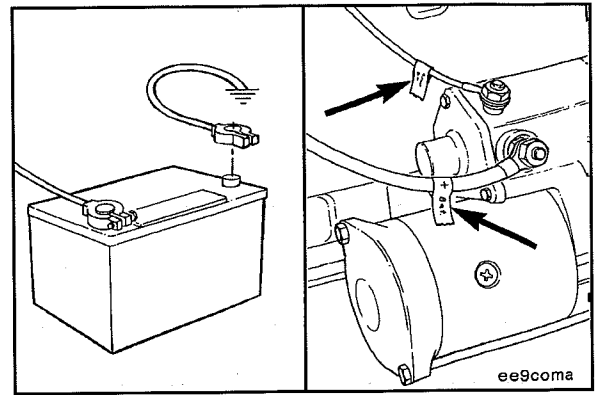

Remove

Remove the battery cable from the solenoid.
Remove all other wires connected to the starter.

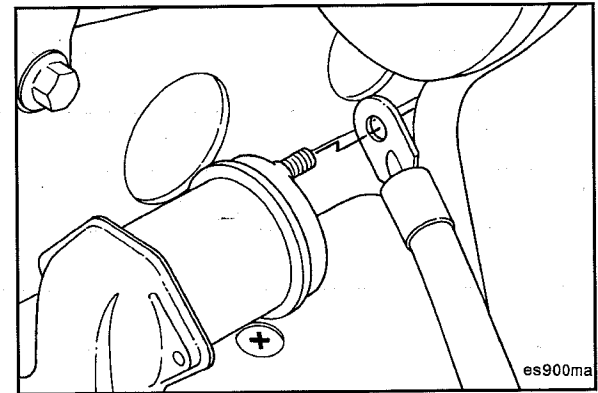

Remove the starter motor.

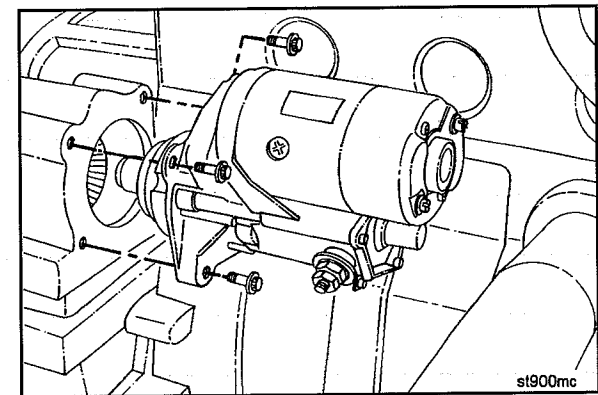

Install



Always connect the ground or negative (-) cable last to avoid arcing that can ignite explosive battery gases.

Install the starter motor.

Connect all cables, connecting ground (-) last.

Torque Value: 43 N•m [32 ft-lb]

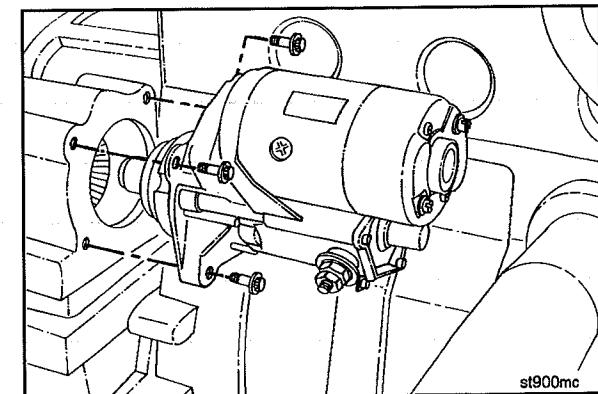

Section D - System Diagrams

Section Contents

	Page
Flow Diagram, Compressed Air System	D-13
Flow Diagram.....	D-13
Flow Diagram, Cooling System	D-7
General Information.....	D-7
Flow Diagram, Exhaust System	D-12
General Information.....	D-12
Flow Diagram, Fuel System	D-2
General Information.....	D-2
Flow Diagram, Lubricating Oil System	D-3
Flow Diagram.....	D-3
Lubrication for the Overhead.....	D-6
Lubrication for the Power Components.....	D-5
Lubrication for the Turbocharger.....	D-4
System Diagrams - Overview	D-1
General Information.....	D-1

Copyright © 2000 by General Motors Corporation

Engine Control System - Fuel System

The fuel system is responsible for delivering fuel to the engine cylinders. It consists of the fuel tank, fuel filter, fuel pump, fuel lines, and fuel injectors. The fuel pump draws fuel from the tank and sends it to the fuel filter. The fuel filter removes any contaminants from the fuel. The fuel pump then sends the fuel to the fuel injectors, which spray the fuel into the cylinders. The fuel injectors are controlled by the engine control system.

This Page Left Intentionally Blank

System Diagrams - Overview

General Information

The following drawings show the flow through the engine systems. Although parts can change between different applications and installations, the flow remains the same. The systems shown are:

- Fuel System
- Lubricating Oil System
- Coolant System
- Intake Air System
- Exhaust System
- Compressed Air System.

Knowledge of the engine systems can help you in troubleshooting, service, and general maintenance of your engine.

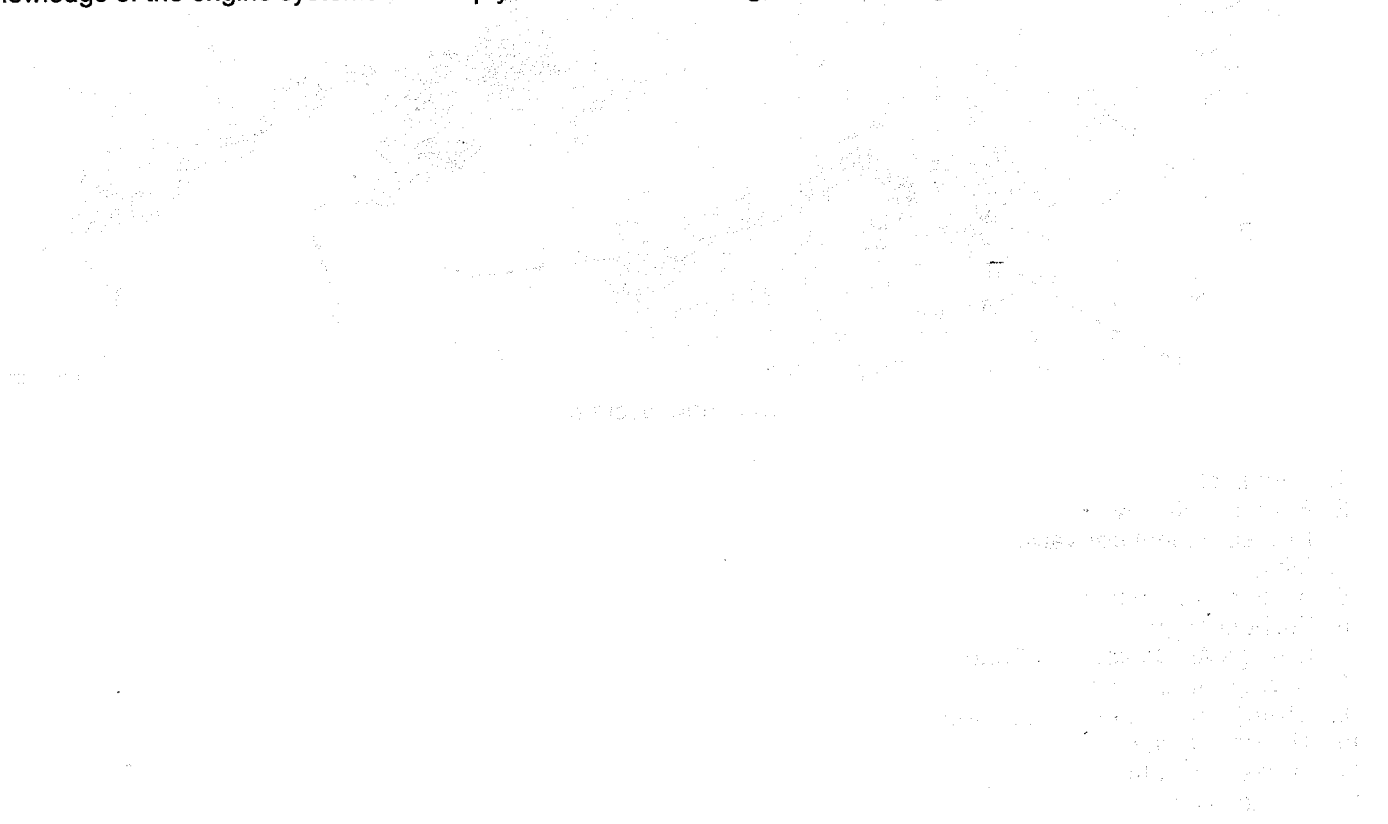

Flow Diagram, Fuel System

General Information

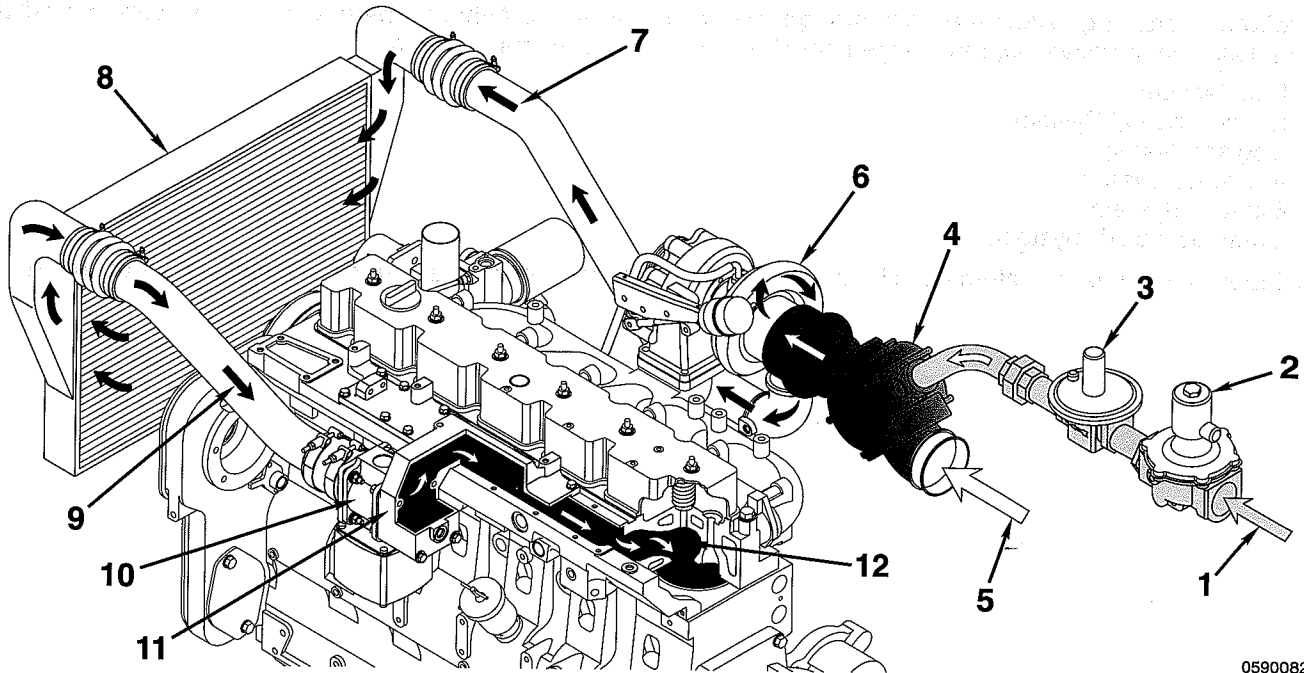

Gas Flow System

05900823

1. Fuel inlet
2. Fuel shutoff valve
3. Pressure regulator valve
4. Mixer
5. Air Inlet from Filter
6. Turbocharger
7. Charge Air Cooler Inlet Tube
8. Charge Air Cooler
9. Charge Air Cooler Outlet Tube
10. Throttle actuator
11. Intake manifold
12. Intake valve

Flow Diagram, Lubricating Oil System

Flow Diagram

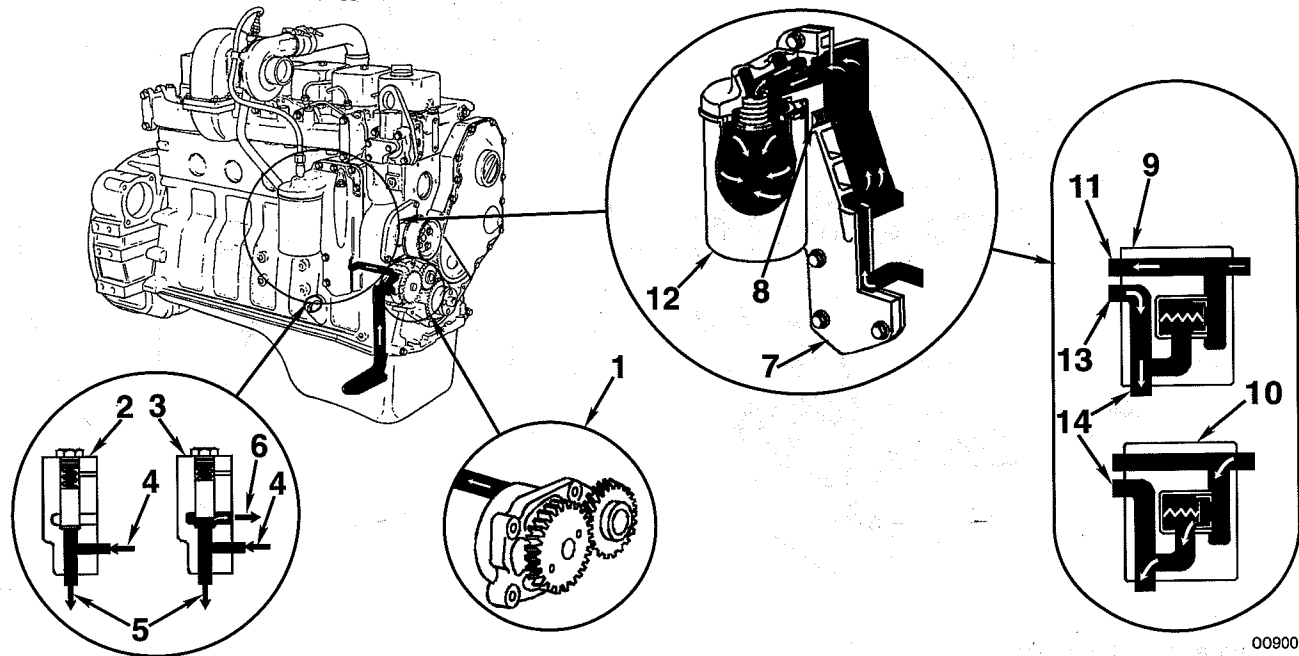

00900371

1. Lubricating Oil Pump
2. Pressure Regulating Valve Closed
3. Pressure Regulating Valve Open
4. From Lubricating Oil Pump
5. To Lubricating Oil Cooler
6. To Lubricating Oil Pan
7. Lubricating Oil Cooler
8. Filter Bypass Valve
9. Filter Bypass Valve Closed
10. Filter Bypass Valve Open
11. To Lubricating Oil Filter
12. Lubricating Oil Filter
13. From Lubricating Oil Filter
14. Main Lubricating Oil Rifle.

Lubrication for the Turbocharger

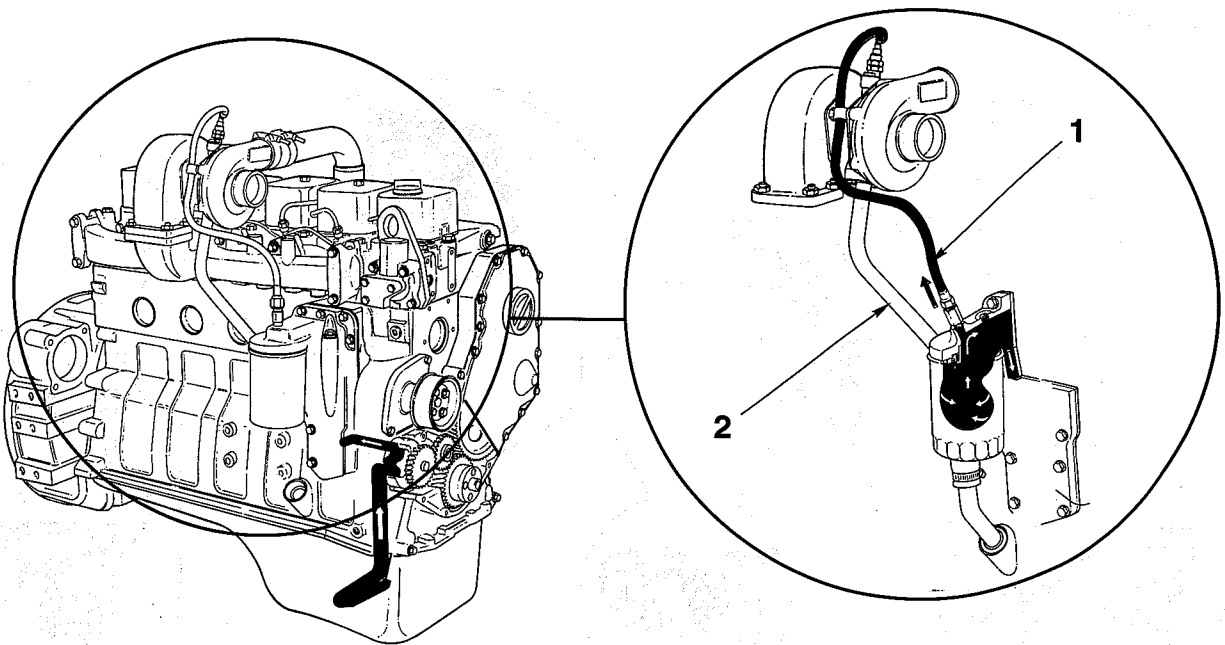

07900188

- 1. Lubricating Oil Supply
- 2. Lubricating Oil Drain.

Lubrication for the Power Components

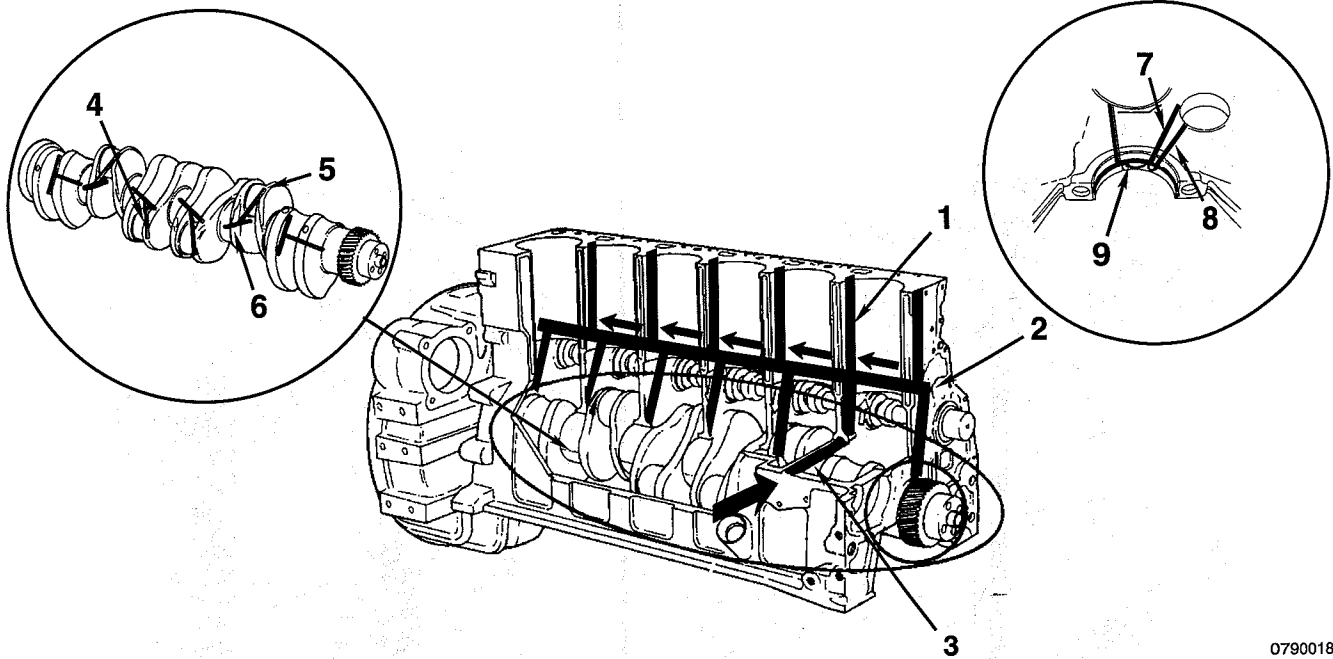

07900187

1. To Valve Train
2. Main Lubricating Oil Rifle
3. From Lubricating Oil Cooler
4. Connecting Rod Journal
5. To Connecting Rod Bearing
6. Crankshaft Main Journal
7. From Main Lubricating Oil Rifle
8. To Camshaft
9. To Piston Cooling Nozzle.

Lubrication for the Overhead

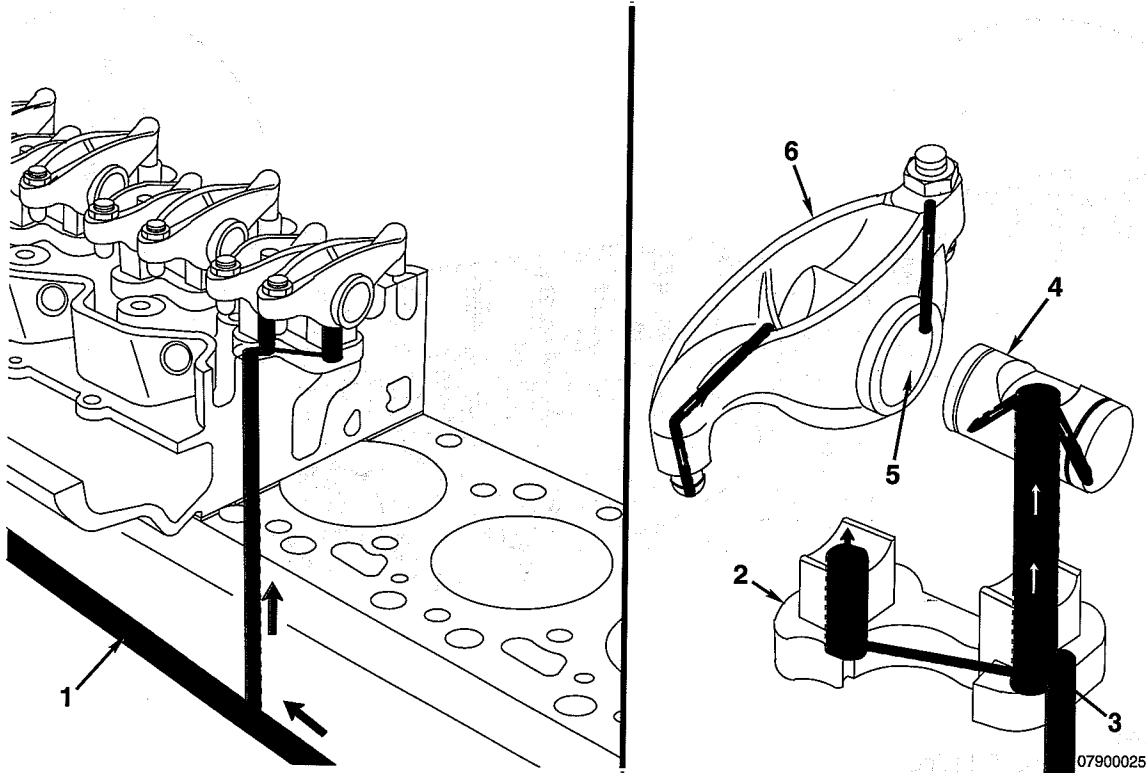

1. Main Lubricating Oil Rifle
2. Rocker Lever Support
3. Transfer Slot
4. Rocker Lever Shaft
5. Rocker Lever Bore
6. Rocker Lever.

Flow Diagram, Cooling System

General Information

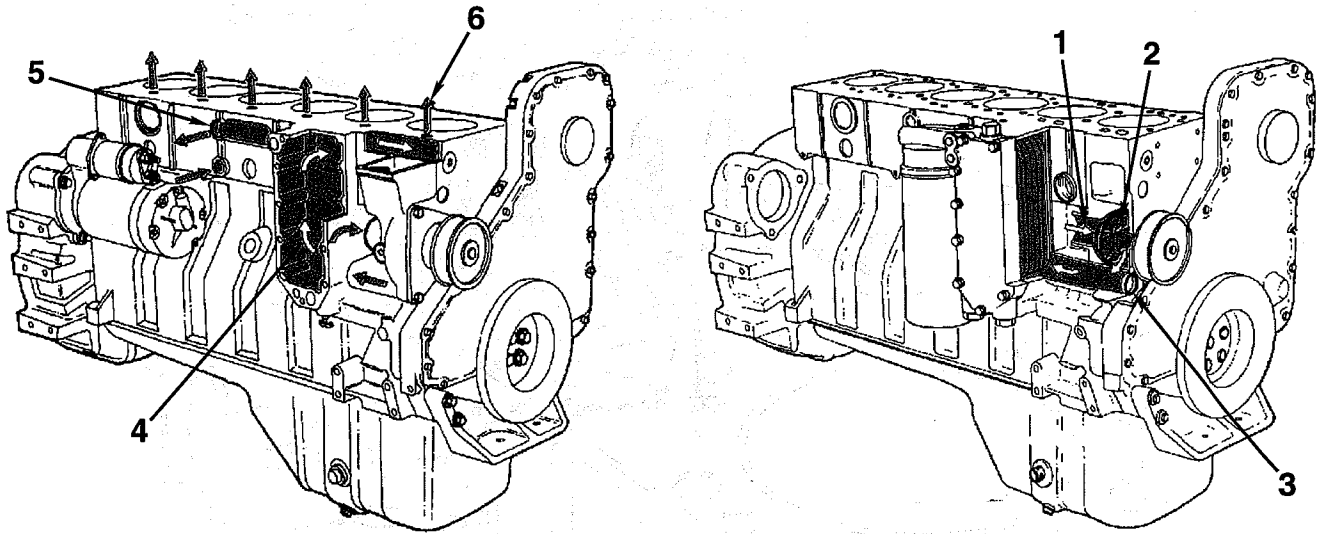

08900201

1. Coolant inlet
2. Water pump impeller
3. Coolant flow to oil cooler
4. Coolant flow past oil cooler
5. Upper coolant manifold
6. Coolant flow to cylinder head.

Flow Diagram, Cooling System

General Information

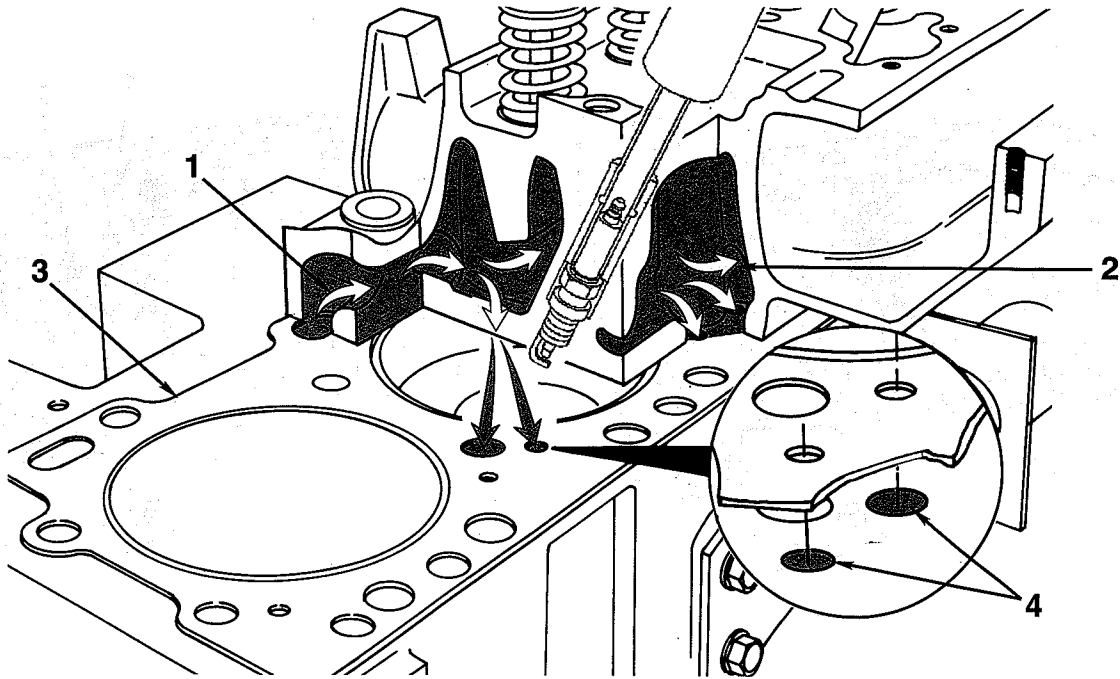

08900275

1. Flow from upper coolant manifold
2. Flow to liner cavity
3. Cylinder head gasket
4. Coolant flow orifice.

Copyright © 2000 GM Corp. All rights reserved.
This document is the property of GM Corp. It is to be used only for the purpose
indicated. It is not to be distributed, copied, or reproduced in any form
without the written permission of GM Corp.

Flow Diagram, Cooling System

General Information

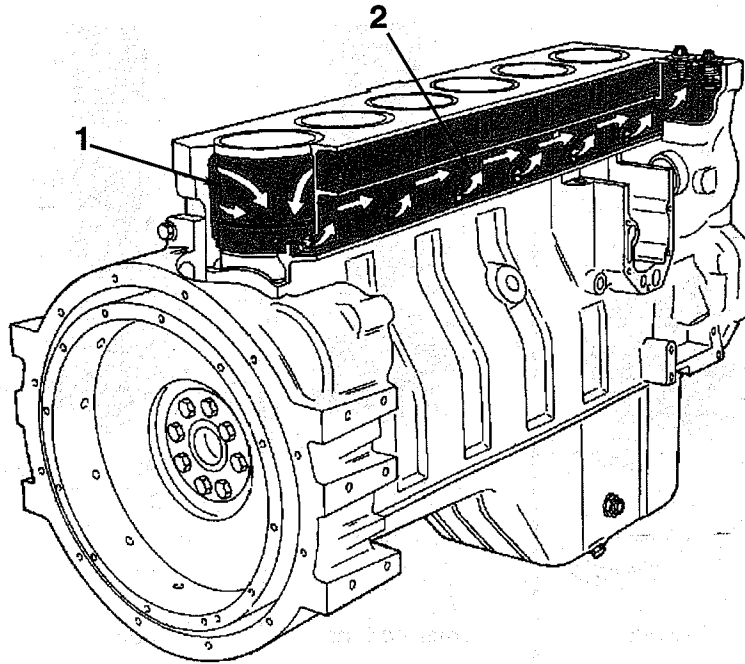

1. Flow past cylinder liners
2. Lower coolant manifold.

08900200

Flow Diagram, Cooling System

General Information

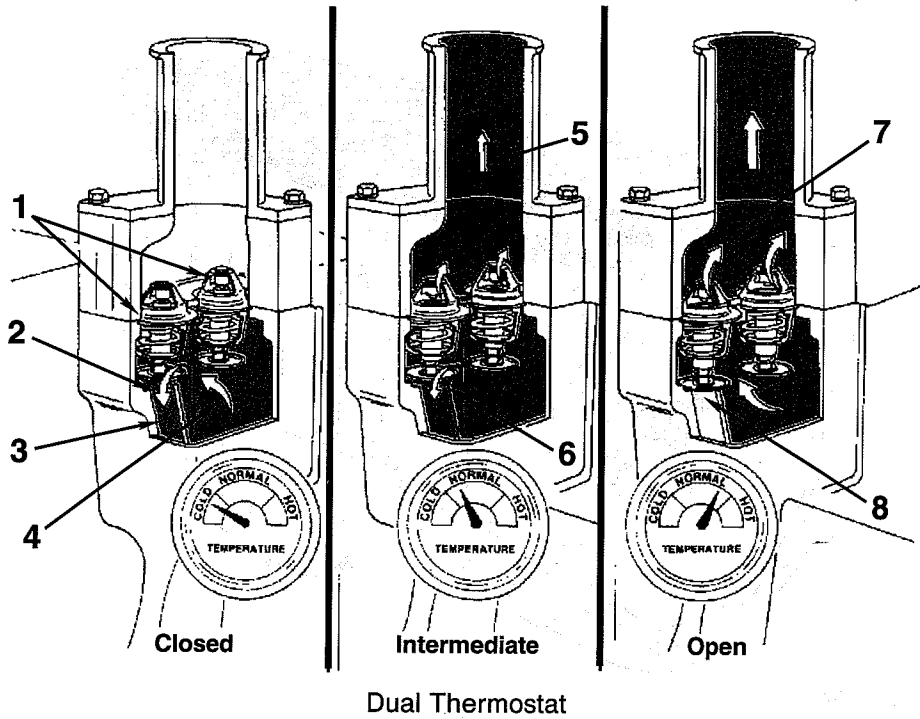

08900202

© 1997 GM Corp. All rights reserved.
GM Corp. Warrendale, PA 15090

1. Thermostats
2. Flow to water pump inlet
3. Bypass passage
4. Flow from lower coolant manifold
5. Partial coolant flow to radiator
6. Restricted flow to bypass
7. Flow to radiator
8. Bypass closed.

Flow Diagram, Cooling System

General Information

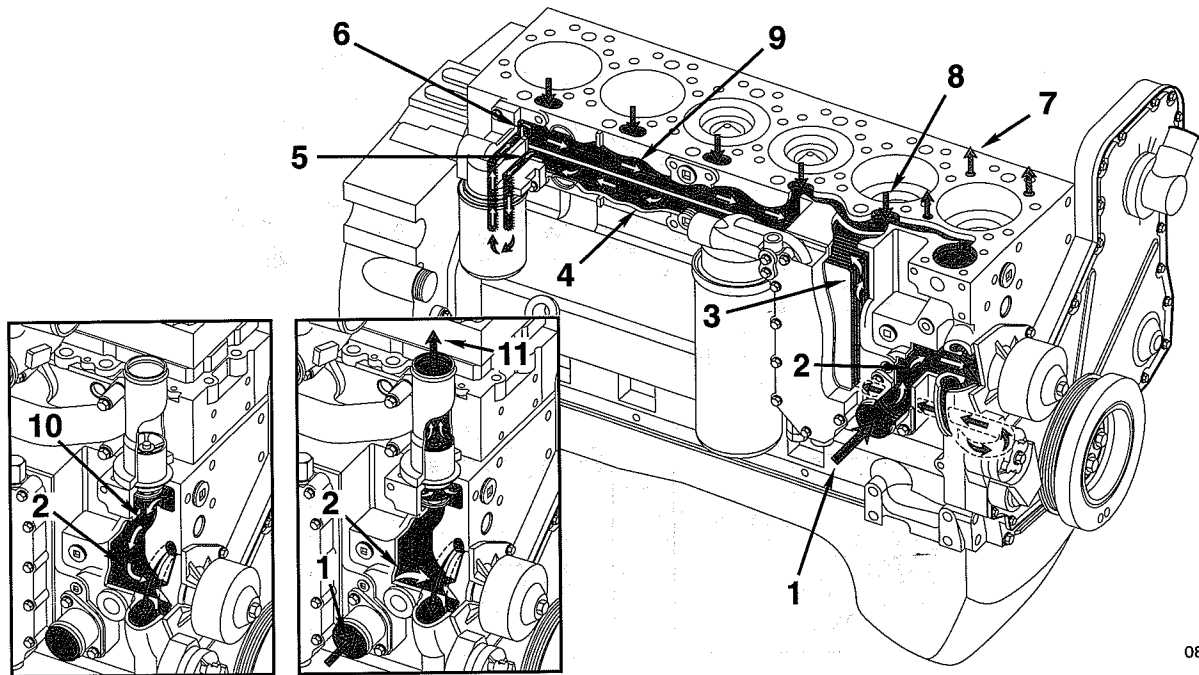

08900119

Single Thermostat

1. Coolant inlet from radiator
2. Water pump suction
3. Coolant flow through lubricating oil cooler
4. Block lower water manifold (to cylinders)
5. Coolant filter inlet
6. Coolant filter outlet
7. Coolant supply to cylinder head
8. Coolant return from cylinder head
9. Block upper water manifold
10. Thermostat bypass
11. Coolant return to radiator.

Flow Diagram, Exhaust System

General Information

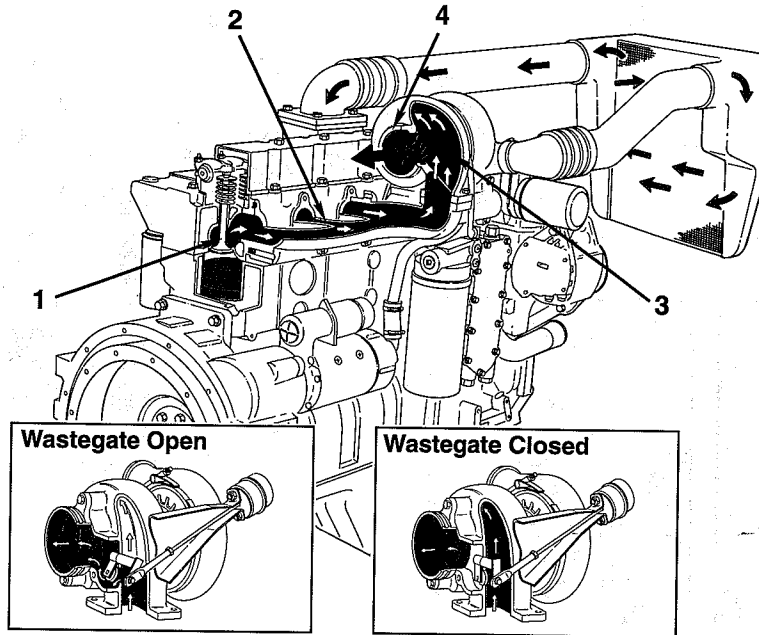

1. Exhaust valve
2. Exhaust manifold - pulse type
3. Dual entry to turbocharger
4. Turbocharger exhaust outlet.

11900058

Flow Diagram, Compressed Air System

Flow Diagram

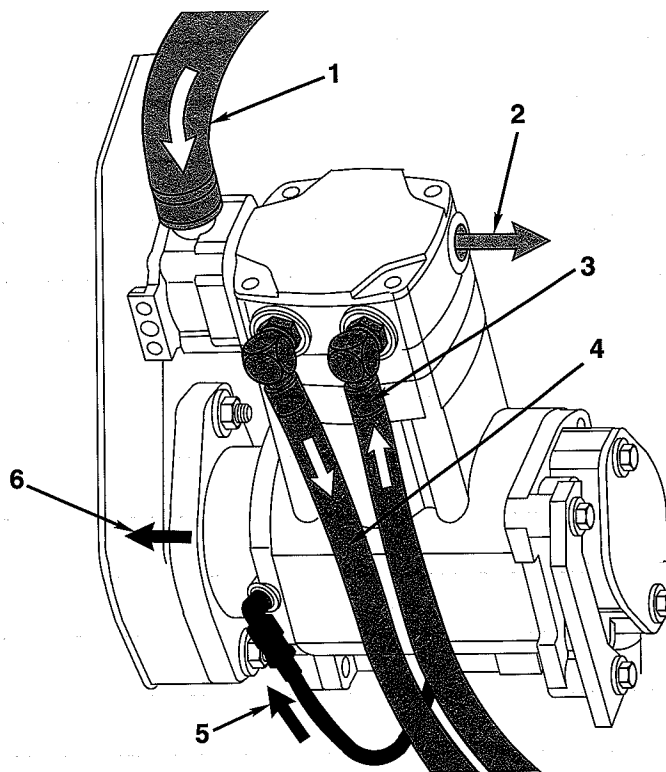

12900030

1. Air In
2. Air Out
3. Coolant In
4. Coolant Out
5. Lubricating Oil In
6. Lubricating Oil Out Is Internal to the Gear Housing.

Section L - Service Literature

Section Contents

	Page
Additional Service Literature	L-1
General Information.....	L-1
Cummins Customized Parts Catalog	L-3
General Information.....	L-3
Ordering the Customized Parts Catalog.....	L-3
Ordering by Telephone.....	L-3
Ordering On-Line.....	L-3
Service Literature Ordering Location	L-2
Contact Information.....	L-2

Section L - Service Literature

Section L - Service Literature

This Page Left Intentionally Blank

Additional Service Literature

General Information

The following publications can be purchased by contacting the nearest local Distributor.

Bulletin	Title of Publication
3666121	Holset® Air Compressor Master Repair Manual
3666132	Cummins Coolant Requirements and Maintenance Bulletin
3666286	Cummins Requirements for Cooling System Extended Service Intervals
3379001	Fuels for Cummins Engines
3810340	Cummins Engine Oil Recommendations
3666003	Troubleshooting and Repair Manual, C Series
4021404	Mechanical Gas Fuel System, Master Repair Manual

Installation Recommendations Bulletins:

3379009	Operation - Cold Weather Bulletin
3379000	Air for Your Engine

Service Literature Ordering Location Contact Information

Region

United States and Canada

U.K., Europe, Mid-East, Africa,
and Eastern European Countries

South and Central America
(excluding Brazil and Mexico)

Brazil and Mexico

Far East (excluding
Australia and New Zealand)

Australia and New Zealand

Ordering Location

Cummins Distributors

or

Credit Cards at 1-800-646-5609

or

Order online at www.powerstore.cummins.com

Cummins Engine Co., Ltd.

Royal Oak Way South

Daventry

Northants, NN11 5NU, England

Cummins Americas, Inc.

16085 N.W. 52nd Avenue

Hialeah, FL 33104

Cummins Inc.

International Parts Order Dept., MC 40931

Box 3005

Columbus, IN 47202-3005

Cummins Diesel Sales Corp.

Literature Center

8 Tanjong Penjuru

Jurong Industrial Estate

Singapore

Cummins Diesel Australia

Maroondah Highway, P.O.B. 139

Ringwood 3134

Victoria, Australia

Cummins Customized Parts Catalog

General Information

Cummins is pleased to announce the availability of a parts catalog compiled specifically for you. Unlike the generic versions of parts catalogs that support general high volume parts content; Cummins Customized catalogs contains only the new factory parts that were used to build your engine.

The catalog cover, as well as the content, is customized with you in mind. You can use it in your shop, at your worksite, or as a coffee table book in your RV or boat. The cover contains your name, company name, address, and telephone number. Your name and engine model identification even appears on the catalog spine. Everybody will know that Cummins created a catalog specifically for you.

This new catalog was designed to provide you with the exact information you need to order parts for your engine. This will be valuable for customers that do not have easy access to the Cummins Electronic Parts Catalog or the Cummins Parts Microfilm System.

Additional Features of the Customized Catalog include:

- Engine Configuration Data
- Table of Contents
- Separate Option and Parts Indexes
- Service Kits (when applicable)
- ReCon Part Numbers (when applicable)

Ordering the Customized Parts Catalog

Ordering by Telephone

North American customers can contact their Cummins Distributor or call Gannett Direct Marketing Services at 1-800-646-5609 and order by credit card. Outside North America order on-line or make an International call to Gannett at (+ +)502-454-6660.

Ordering On-Line

The Customized Parts Catalog can be ordered On-Line from the Cummins Powerstore by credit card. Contact the Powerstore at WWW.POWERSTORE.CUMMINS.COM

Contact GDMS or the CUMMINS POWERSTORE for the current price; Freight may be an additional expense.

Information we need to take your Customized Parts Catalog Order. This information drives the cover content of the CPC.

- Customer Name
- Street Address
- Company Name (optional)
- Telephone no.
- Credit Card No.
- Cummins Engine Serial Number (located on the engine data plate)
- Please identify the required media: Printed Catalog, CD-ROM, or PDF File

Unfortunately not all Cummins Engines can be supported by this parts catalog. Engines older than 1984 or newer than 3 months may not have the necessary parts information to compile a catalog. We will contact you if this occurs and explain why we are unable to fill your order.

Customized Parts Catalogs are produced specifically for a single customer. This means they are not returnable for a refund. If we make an error and your catalog is not useable, we will correct that error by sending you a new catalog.

Section M - Component Manufacturers

Section Contents

	Page
Component Manufacturers' Addresses	M-1
Air Compressors.....	M-1
Air Cylinders.....	M-1
Air Heaters.....	M-1
Air Starting Motors.....	M-1
Alternators.....	M-1
Auxiliary Brakes.....	M-1
Belts.....	M-1
Catalytic Converters.....	M-1
Coolant Level Switches.....	M-1
Clutches.....	M-1
Coolant Heaters.....	M-2
Drive Plates.....	M-2
Electric Starting Motors.....	M-2
Electronic Switches.....	M-2
Engine Protection Controls.....	M-2
Fan Clutches.....	M-2
Fans.....	M-2
Fault Lamps.....	M-2
Filters.....	M-2
Flexplates.....	M-2
Fuel Coolers.....	M-2
Fuel Pumps.....	M-2
Fuel Warmers.....	M-2
Gauges.....	M-3
Governors.....	M-3
Heat Sleeves.....	M-3
Hydraulic and Power Steering Pumps.....	M-3
In-Line Connectors.....	M-3
Oil Heaters.....	M-3
Prelubrication Systems.....	M-3
Radiators.....	M-3
Throttle Assemblies.....	M-3
Torque Converters.....	M-3

Section M - Component Manufacturers

Section M - Component Manufacturers

This Page Left Intentionally Blank

Component Manufacturers' Addresses

NOTE: The following list contains addresses and telephone numbers of suppliers of accessories used on Cummins engines. Suppliers can be contacted directly for any specifications **not** covered in this manual.

Air Compressors

Bendix Heavy Vehicles Systems
Div. of Allied Automotive
901 Cleveland Street
Elyria, OH 44036
Telephone: (216) 329-9000

Holset Engineering Co., Inc.
1320 Kemper Meadow Drive
Suite 500
Cincinnati, OH 45240
Telephone: (513) 825-9600

Midland-Grau
Heavy Duty Systems
Heavy Duty Group Headquarters
10930 N. Pamona Avenue
Kansas City, MO 64153
Telephone: (816) 891-2470

Air Cylinders

Bendix Ltd.
Douglas Road
Kingswood
Bristol
England
Telephone: 0117-671881

Catching Engineering
1733 North 25th Avenue
Melrose Park, IL 60160
Telephone: (708) 344-2334

TEC - Hackett Inc.
8909 Rawles Avenue
Indianapolis, IN 46219
Telephone: (317) 895-3670

Air Heaters

Fleetguard, Inc.
1200 Fleetguard Road
Cookeville, TN 38502
Telephone: (615) 526-9551

Kim Hotstart Co.
P.O. Box 11245
Spokane, WA 99211-0245
Telephone: (509) 534-6171

Air Starting Motors

Ingersoll Rand
Chorley New Road
Horwich
Bolton
Lancashire
England
BL6 6JN
Telephone: 01204-65544

Ingersoll-Rand Engine
Starting Systems
888 Industrial Drive
Elmhurst, IL 60126
Telephone: (708) 530-3875

StartMaster
Air Starting Systems
A Division of Sycon Corporation
9595 Cheney Avenue
P. O. Box 491
Marion, OH 43302
Telephone: (614) 382-5771

Alternators

Robert Bosch Ltd.
P.O. Box 98
Broadwater Park
North Orbital Road
Denham
Uxbridge
Middlesex UD9 5HG
England
Telephone: (0)1895-838383

Prestolite Electrics
Cleveland Road
Leyland
PR5 1XB
England
Telephone: (0)1772-421663

C. E. Niehoff & Co.
2021 Lee Street
Evanston, IL 60202
Telephone: (708) 866-6030

Delco-Remy America
2401 Columbus Avenue
P.O. Box 2439
Anderson, IN 46018
Telephone: (317) 646-3528

Leece-Neville Corp.
400 Main Street
Arcade, NY 14009
Telephone: (716) 492-1700

Auxiliary Brakes

The Jacobs Manufacturing Company
Vehicle Equipment Division
22 East Dudley Town Road
Bloomfield, CT 06002
Telephone: (203) 243-1441

Belts

T.B.A. Belting Ltd.
P.O. Box 77
Wigan
Lancashire
WN2 4XQ
England
Telephone: (0)1942-259221

Dayco Mfg.
Belt Technical Center
1955 Enterprize
Rochester Hills, MI 48309
Telephone: (810) 853-8300

Gates Rubber Company
900 S. Broadway
Denver, CO 80217

Goodyear Tire and
Rubber Company
Industrial Products Div.
2601 Fortune Circle East
Indianapolis, IN 46241
Telephone: (317) 898-4170

Catalytic Converters

Donaldson Company, Inc.
1400 West 94th Street
P.O. Box 1299
Minneapolis, MN 55440
Telephone: (612) 887-3835

Nelson Division
Exhaust and Filtration Systems
1801 U.S. Highway 51 P.O. Box 428
Stoughton, WI 53589
Telephone: (608) 873-4200

Walker Manufacturing
3901 Willis Road
P.O. Box 157
Grass Lake, MI 49240
Telephone: (517) 522-5500

Coolant Level Switches

Robertshaw Controls Company
P.O. Box 400
Knoxville, TN 37901
Telephone: (216) 885-1773

Clutches

Twin Disc International S.A.
Chaussee de Namur
Nivelles
Belguim
Telephone: 067-224941

Twin Disc Incorporated
1328 Racine Street
Racine, WI 53403
Telephone: (414) 634-1981

Coolant Heaters

Fleetguard, Inc.
1200 Fleetguard Road
Cookeville, TN 38502
Telephone: (615) 526-9551

Drive Plates

Detroit Diesel Allison
Division of General Motors
Corporation
P.O. Box 894
Indianapolis, IN 46206-0894
Telephone: (317) 242-5000

Electric Starting Motors

Prestolite Electrics
Cleveland Road
Leyland
PR5 1XB
England
Telephone: 01772-421663

Delco-Remy America
2401 Columbus Avenue
P.O. Box 2439
Anderson, IN 46018
Telephone: (317) 646-3528

Leece-Neville Corp.
400 Main Street
Arcade, NY 14009
Telephone: (716) 492-1700

Nippondenso Inc.
2477 Denso Drive
P.O. Box 5133
Southfield, MI 48086
Telephone: (313) 350-7500

Electronic Switches

Cutler-Hammer Products
Eaton Corporation
4201 N. 27th Street
Milwaukee, WI 53216
Telephone: (414) 449-6600

Engine Protection Controls

Flight Systems Headquarters
Hempt Road
P.O. Box 25
Mechanicsburg, PA 17055
Telephone: (717) 697-0333

The Nason Company
2810 Blue Ridge Blvd.
West Union, SC 29696
Telephone: (803) 638-9521

Teddington Industrial
Equipment
Windmill Road
Sunbury on Thames
Middlesex
TW16 7HF
England
Telephone: (0)9327-85500

Fan Clutches

Kysor Cooling Systems N.A.
6040 West 62nd Street
Indianapolis, IN 46278
Telephone: (317) 328-3330

Holset Engineering Co. Ltd.
ST Andrews Road
Huddersfield, West Yorkshire
England HD1 6RA
Telephone: (0)1484-22244

Horton Industries, Inc.
P.O. Box 9455
Minneapolis, MN 55440
Telephone: (612) 378-6410

Rockford Clutch Company
1200 Windsor Road
P.O. Box 2908
Rockford, IL 61132-2908
Telephone: (815) 633-7460

Fans

Truflo Ltd.
Westwood Road
Birmingham
B6 7JF
England
Telephone: (0)121-3283041

Hayes-Albion Corporation
Jackson Manufacturing Plant
1999 Wildwood Avenue
Jackson, MI 49202
Telephone: (517) 782-9421

Engineered Cooling Systems, Inc.
201 W. Carmel Drive
Carmel, IN 46032
Telephone: (317) 846-3438

Brookside Corporation
P.O. Box 30
McCordsville, IN 46055
Telephone: (317) 335-2014

TCF Aerovent Company
9100 Purdue Rd., Suite 101
Indianapolis, IN 46268-1190
Telephone: (317) 872-0030

Kysor-Cadillac
1100 Wright Street
Cadillac, MI 49601
Telephone: (616) 775-4681

Schwitzer
6040 West 62nd Street
P.O. Box 80-B
Indianapolis, IN 46206
Telephone: (317) 328-3010

Fault Lamps

Cutler-Hammer Products
Eaton Corporation
4201 N. 27th Street
Milwaukee, WI 53216
Telephone: (414) 449-6600

Filters

Fleetguard International Corp.
Cavalry Hill Industrial Park
Weedon
Northampton NN7 4TD
England
Telephone: 01327-341313

Fleetguard, Inc.
1200 Fleetguard Road
Cookeville, TN 38502
Telephone: 1-800-22-Filters
(1-800-223-4583)

Flexplates

Corrugated Packing and
Sheet Metal
Hamsterley
Newcastle Upon Tyne
England
Telephone: (0)1207-560-505

Allison Transmission
Division of General Motors
Corporation
P.O. Box 894
Indianapolis, IN 46206-0894
Telephone: (317) 242-5000

Midwest Mfg. Co.
29500 Southfield Road, Suite 122
Southfield, MI 48076
Telephone: (313) 642-5355

Wohlert Corporation
708 East Grand River Avenue
P.O. Box 20217
Lansing, MI 48901
Telephone: (517) 485-3750

Fuel Coolers

Hayden, Inc.
1531 Pomona Road
P.O. Box 848
Corona, CA 91718-0848
Telephone: (909) 736-2665

Fuel Pumps

Robert Bosch Corp.
Automotive Group
2800 South 25th Ave.
Broadview, IL 60153

Fuel Warmers

Fleetguard, Inc.
1200 Fleetguard Road
Cookeville, TN 38502
Telephone: (615) 526-9551

Gauges

Grasslin U.K. Ltd.
Vale Rise
Tonbridge
Kent
TN9 1TB
England
Telephone: (0)1732-359888

Datcon Instruments
P.O. Box 128
East Petersburg, PA 17520
Telephone: (717) 569-5713

Rochester Gauges, Inc.
11616 Harry Hines Blvd.
P.O. Box 29242
Dallas, TX 75229
Telephone: (214) 241-2161

Governors

Woodward Governor Co.
P.O. Box 1519
Fort Collins, CO 80522
Telephone: (303) 482-5811
(800) 523-2831

Barber Colman Co.
1354 Clifford Avenue
Loves Park, IL 61132
Telephone: (815) 637-3000

United Technologies
Diesel Systems
1000 Jorie Blvd.
Suite 111
Oak Brook, IL 69521
Telephone: (312) 325-2020

Heat Sleeves

Bentley Harris Manufacturing Co.
100 Bentley Harris Way
Gordonville, TN 38563
Telephone: (313) 348-5779

Hydraulic and Power Steering Pumps

Honeywell Control Systems Ltd.
Honeywell House
Arlington Business Place
Bracknell
Berks RG12 1EB
Telephone: (0)1344-656000

Sperry Vickers
P.O. Box 302
Troy, MI 48084
Telephone: (313) 280-3000

Z.F.
P.O. Box 1340
Grafvonsoden Strasse
5-9 D7070
Schwaebisch Gmuend
Germany
Telephone: 7070-7171-31510

In-Line Connectors

Pioneer-Standard Electronics, Inc.
5440 Neiman Parkway
Solon, OH 44139
Telephone: (216) 349-1300

Deutsch
Industrial Products Division
37140 Industrial Avenue
Hemet, CA 92343
Telephone: (714) 929-1200

Oil Heaters

Fleetguard, Inc.
1200 Fleetguard Road
Cookeville, TN 38502
Telephone: (615) 526-9551

Kim Hotstart Co.
P.O. Box 11245
Spokane, WA 99211-0245
Telephone: (509) 534-6171

Prelubrication Systems

RPM Industries, Inc.
Suite 109
55 Hickory Street
Washington, PA 15301
Telephone: (412) 228-5130

Radiators

JB Radiator Specialties, Inc.
P.O. Box 292087
Sacramento, CA 95829-2087
Telephone: (916) 381-4791

The G&O Manufacturing Company
100 Gando Drive
P.O. Box 1204
New Haven, CT 06505-1204
Telephone: (203) 562-5121

Young Radiator Company
2825 Four Mile Road
Racine, WI 53404
Telephone: (910) 271-2397

L and M Radiator, Inc.
1414 East 37th Street
Hibbing, MN 55746
Telephone: (218) 263-8993

Throttle Assemblies

Williams Controls, Inc.
14100 SW 72nd Avenue
Portland, OR 97224
Telephone: (503) 684-8600

Torque Converters

Twin Disc International S.A.
Chaussee de Namur
Nivelles
Belgium
Telephone: 067-224941

Twin Disc Incorporated
1328 Racine Street
Racine, WI 53403-1758
Telephone: (414) 634-1981

Rockford Powertrain, Inc.
Off-Highway Systems
1200 Windsor Road
P.O. Box 2908
Rockford, IL 61132-2908
Telephone: (815) 633-7460

Modine Mfg. Co.
1500 DeKoven Avenue
Racine, WI 53401
Telephone: (414) 636-1640

Section S - Service Assistance

Section Contents

	Page
Distributors - International	S-36
Locations.....	S-36
Distributors and Branches	S-3
Australia.....	S-24
Canada.....	S-21
New Zealand.....	S-28
United States.....	S-3
Division and Regional Offices	S-2
Locations.....	S-2
Emergency and Technical Service	S-1
General Information.....	S-1
Problem Solving	S-1
General Information.....	S-1
Regional Offices - International	S-29
Locations.....	S-29
Routine Service and Parts	S-1
General Information.....	S-1

Section S - Service Assistance

Section S - Service Assistance

Faint, illegible text, likely bleed-through from the reverse side of the page.

This Page Left Intentionally Blank

Routine Service and Parts

General Information

Personnel at Cummins Authorized Repair Locations can assist you with the correct operation and service of your engine. Cummins has a worldwide service network of more than 5,000 Distributors and Dealers who have been trained to provide sound advice, expert service, and complete parts support. Check the telephone directory yellow pages or refer to the directory in this section for the nearest Cummins Authorized Repair Location.

Emergency and Technical Service

General Information

The Cummins Customer Assistance Center provides a 24-hour, toll free telephone number to aid in technical and emergency service when a Cummins Authorized Repair Location can **not** be reached or is unable to resolve an issue with a Cummins product.

If additional assistance is required, call Toll-Free:

1-800-DIESELS
(1-800-343-7357)

- Includes all 50 states, Bermuda, Puerto Rico, Virgin Islands, and the Bahamas.
- Outside of North America contact your Regional Office. Telephone numbers and addresses are listed in the International Directory.

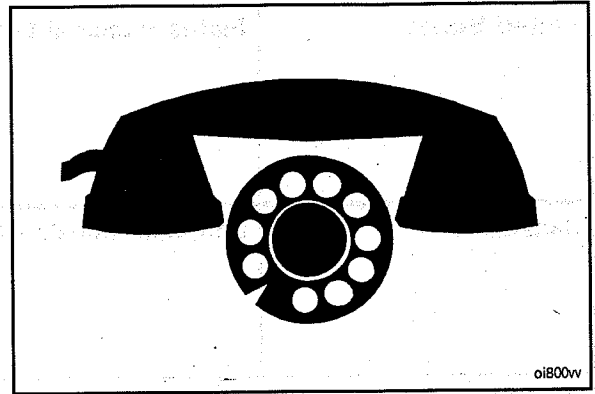

Problem Solving

General Information

Normally, any problem that arises with the sale, service, or repair of your engine can be handled by a Cummins Authorized Repair Location in your area. Refer to the telephone directory yellow pages for the one nearest you. If the problem has **not** been handled satisfactorily, follow the steps outlined below:

1. If the disagreement is with a Dealer, talk to the Cummins Distributor with whom he has his service agreement.
2. If the disagreement is with a Distributor, call the nearest Cummins Division or Regional Office; however, most problems are solved below the Division or Regional office level. Telephone numbers and addresses are listed in this section. Before calling, write down the following information:
 - a. Engine model and serial number
 - b. Type and make of equipment
 - c. Total kilometers [miles] or hours of operation
 - d. Warranty start date
 - e. Nature of problem
 - f. Summary of the current problem arranged in the order of occurrence
 - g. Name and location of the Cummins Distributor or Dealer
12. If a problem can **not** be resolved satisfactorily through your Cummins Authorized Repair Location or Division Office, write to:

Cummins Customer Assistance Center - 41403, Cummins Inc., Box 3005, Columbus, IN 47202-3005

Division and Regional Offices - Locations

NOTE: The following list contains offices in U.S., Canada, Australia, New Zealand, and Puerto Rico.

United States	Southern Division Office	Cummins Engine Company, Inc. 425 Franklin Road S.W. Suite 500 Marietta, GA 30067 Telephone: (770) 423-1108 FAX: (770) 499-8240
United States	Plains Regional Office	Cummins Engine Company, Inc. 1901 Central Drive Suite 356 Bedford, TX 76021 Telephone: (817) 267-3172 FAX: N/A
Canada	Canadian Division Office	Cummins Diesel of Canada, Ltd. 5575 North Service Road Burlington, Ontario L7Z6M1 Telephone: (905) 331-5944 FAX: (905) 331-0276
Canada	Western Canada Regional Office	Cummins Diesel of Canada, Ltd. 18452 - 96th Avenue Surrey, B.C. V3T 4W2 Telephone: (604) 882-5727 FAX: (604) 882-9110
Canada	Eastern Canada Regional Office	Cummins Diesel of Canada Ltd. 7200 Trans Canada Hwy. Pt. Cuaire, Quebec H9R 1C0 Telephone: (514) 695-2402 FAX: (514) 695-8917
Canada	Central Canada Regional Office	Cummins Diesel of Canada Ltd. 4887 - 35th Street SE Calgary, Alberta T2B 3C6 FAX: (403) 569-9974
Australia Regional Office	Cummins Engine Company Pty. Ltd.	2 Caribbean Drive Scoresby, Victoria 3179 Australia Telephone: (61-3) 9765-3222 FAX: (61-3) 9763-0079 NOTE: This office also serves New Zealand.
Cummins Americas Regional Office	Cummins Latin America	3088 N. Commerce Parkway MPC #14, Building A Miramar, FL 33025 Telephone: (305) 621-1300 NOTE: This office serves Puerto Rico and South America excluding Brazil.

Distributors and Branches - United States

Alabama	Birmingham Distributor	Cummins Alabama, Inc. 2200 Pinson Highway P.O. Box 1147 Birmingham, AL 35201 Telephone: (205) 841-0421 FAX: (205) 849-5926
Alabama	Mobile Branch	Cummins Alabama, Inc. 1924 N. Beltline Hwy. Mobile, AL 36601-1598 Telephone: (334) 456-2236 FAX: (334) 452-6419
Alabama	Mobile Onan/Marine Branch	Cummins Alabama, Inc. 3422 Georgia Pacific Avenue Mobile, AL 36617 Telephone: (334) 452-6426 FAX: (334) 473-6657
Alabama	Montgomery Branch	Cummins Alabama, Inc. 2325 West Fairview Avenue Montgomery, AL 36108 Telephone: (205) 263-2594 FAX: (205) 263-2594
Alaska	Anchorage - (Branch of Seattle)	Cummins Northwest, Inc. 2618 Commercial Drive Anchorage, AK 99501-3095 Telephone: (907) 279-7594 FAX: (907) 276-6340
Arizona	Phoenix Distributor and Branch	Cummins Southwest, Inc. 2239 N. Black Canyon Hgwy Phoenix, AZ 85009 Telephone: (602) 252-8021 FAX: (602) 253-6725
Arizona	Tucson Branch	Cummins Southwest, Inc. 1912 West Prince Road Tucson, AZ 85705 Telephone: (520) 887-7440 FAX: (520) 887-4173
Arkansas	Little Rock - (Branch of Memphis)	Cummins Mid-South, Inc. 6600 Interstate 30 Little Rock, AR 72209 Telephone: Sales: (501) 569-5600 Service: (501) 569-5656 Parts: (501) 569-5613 FAX: (501) 565-2199
California	San Leandro Distributor	Cummins West, Inc. 14775 Wicks Blvd. San Leandro, CA 94577-6779 Telephone: (510) 351-6101 FAX: (510) 352-3925

California	Arcata Branch	Cummins West, Inc. 4801 West End Road Arcata, CA 95521 Telephone: (707) 822-7392 FAX: (707) 822-7585
California	Bakersfield Branch	Cummins West, Inc. 4601 East Brundage Lane Bakersfield, CA 93307 Telephone: (805) 325-9404 FAX: (805) 861-8719
California	Fresno Branch	Cummins West, Inc. 2740 Church Avenue Fresno, CA 93706 Telephone: (209) 495-4745 FAX: (209) 486-7402
California	Redding Branch	Cummins West, Inc. 20247 Charlanne Drive Redding, CA 96001 Telephone: (916) 222-4070 FAX: (916) 224-4075
California	Stockton Branch	Cummins West, Inc. 41 West Yokuts Avenue Suite 131 Stockton, CA 95207 Telephone: (209) 473-0386 FAX: (209) 478-2454
California	West Sacramento Branch	Cummins West, Inc. 2661 Evergreen Avenue West Sacramento, CA 95691 Telephone: (916) 371-0630 FAX: (916) 371-2849
California	Los Angeles Distributor	Cummins Cal Pacific Inc. 1939 Deere Avenue (Irvine) Irvine, CA 92606 Telephone: (949) 253-6000 FAX: (949) 253-6080
California	Montebello Branch	Cummins Cal Pacific Inc. 1105 South Greenwood Avenue Montebello, CA 90640 Telephone: (323) 728-8111 FAX: (323) 889-7422
California	Bloomington Branch	Cummins Cal Pacific Inc. 3061 S. Riverside Avenue Bloomington, CA 92377 Telephone: (909) 877-0433 FAX: (909) 877-3787
California	San Diego Branch	Cummins Cal Pacific Inc. 310 N. Johnson Avenue El Cajon, CA 92020 Telephone: (619) 593-3093 FAX: (619) 593-0600

California	Ventura Branch	Cummins Cal-Pacific Inc. 3958 Transport St. Ventura, CA 93003 Telephone: (805) 644-7281 FAX: (805) 644-7284
Colorado	Denver Distributor	Cummins Rocky Mountain, Inc. 5100 East 58th Avenue Commerce City, CO 80022 Telephone: (303) 287-0201 FAX: (303) 288-7080
Colorado	Denver Onan/Industrial Branch	Cummins Rocky Mountain, Inc. 5100 East 58th Ave. Commerce City, CO 80022 Telephone: (303) 286-7697 FAX: (303) 287-4837
Colorado	Durango Branch	Cummins Rocky Mountain, Inc. 13595 County Road 213 Durango, CO 81301 Telephone: (970) 259-7470 FAX: (970) 259-7482
Colorado	Grand Junction Branch	Cummins Rocky Mountain, Inc. 2380 U.S. Highway 6 & 50 P.O. Box 339 Grand Junction, CO 81501 Telephone: (303) 242-5776 FAX: (303) 243-5495
Connecticut	Rocky Hill - (Branch of Bronx)	Cummins Metropower, Inc. 914 Cromwell Ave. Rocky Hill, CT 06067 Telephone: (860) 529-7474 FAX: (860) 529-7524
Florida	Tampa Distributor	Cummins Southeastern Power, Inc. Corporate Office 5421 N. 59th Street Tampa, FL 33610 Telephone: (813) 621-7202 FAX: (813) 621-8250
Florida	Ft. Myers Branch	Cummins Southeastern Power, Inc. 2671 Edison Avenue Ft. Myers, FL 33902 Telephone: (941) 337-1211 FAX: (941) 337-5374
Florida	Jacksonville Branch	Cummins Southeastern Power, Inc. 755 Pickettville Rd. Jacksonville, FL 32220 Telephone: (904) 378-1902 FAX: (904) 378-1904
Florida	Hialeah (Miami) Branch	Cummins Southeastern Power, Inc. 9900 N.W. 77th Avenue Hialeah Gardens, FL 33016 Telephone: (305) 821-4200 FAX: (305) 557-2992

Florida	Ocala Branch	Cummins Southeastern Power 321 Southwest 52nd Ave. Ocala, FL 34474-1892 Telephone: (352) 861-1122 FAX: (352) 861-1130
Florida	Orlando Branch	Cummins Southeastern Power, Inc. 4020 North Orange Blossom Trail Orlando, FL 32810 Telephone: (407) 298-2080 FAX: (407) 290-8727
Florida	Tampa Branch	Cummins Southeastern Power, Inc. 5912 E. Hillsborough Avenue Tampa, FL 33610 Telephone: (813) 626-1101 FAX: (813) 628-4183
Georgia	Atlanta Distributor	Cummins South, Inc. 5125 Georgia Highway 85 College Park, GA 30349 Telephone: (404) 763-0151 FAX: (404) 766-2132
Georgia	Albany Branch	Cummins South, Inc. 1915 W. Oakridge Drive Albany, GA 31707-4938 Telephone: (912) 888-6210 FAX: (912) 883-1670
Georgia	Atlanta Branch	Cummins South, Inc. 100 University Avenue, S.W. Atlanta, GA 30315-2202 Telephone: (404) 527-7800 FAX: (404) 527-7832
Georgia	Augusta Branch	Cummins South, Inc. 1255 New Savannah Road Augusta, GA 30901-3891 Telephone: (706) 722-8825 FAX: (706) 722-7553
Georgia	Savannah Branch	Cummins South, Inc. 8 Interchange Court Savannah, GA 31401-1627 Telephone: (912) 232-5565 FAX: (912) 232-5145
Hawaii	Kapolei Distributor	Cummins Hawaii Diesel Power, Inc. 91-230 Kalaeloa Blvd. Kapolei, HI 96707 Telephone: (808) 682-8110 FAX: (808) 682-8477
Idaho	Boise - (Branch of Salt Lake City)	Cummins Intermountain, Inc. 2851 Federal Way City Boise, ID 83705 Telephone: (208) 336-5000 FAX: (208) 338-5436

Idaho	Pocatello - (Branch of Salt Lake City)	Cummins Intermountain, Inc. 14299 Highway 30 West Pocatello, ID 83201 Telephone: (208) 234-1661 FAX: (208) 234-1662
Illinois	Chicago Distributor	Cummins Northern Illinois, Inc. 7145 Santa Fe Drive Hodgkins, IL 60525 Telephone: (708) 579-9222 FAX: (708) 352-7547
Illinois	Bloomington-Normal - (Branch of Indianapolis)	Cummins Mid-States Power, Inc. (at U.S. 51 N and I-55) 414 W. Northtown Road Bloomington-Normal, IL 61761 Telephone: (309) 452-4454 FAX: (309) 452-1642
Illinois	Onan Branch	Cummins/Onan Northern Illinois 8745 W. 82nd Place Justin, IL 60458 Telephone: (708) 563-7070 FAX: (708) 563-7095
Illinois	Harrisburg (Branch of St. Louis)	Cummins Gateway, Inc. Highway 45 North Harrisburg, IL 62946 Telephone: (618) 273-4138 FAX: (618) 273-4531
Illinois	Rock Island - (Branch of Omaha)	Cummins Great Plains Diesel, Inc. 7820 - 42nd Street West Rock Island, IL 61204 Telephone: (309) 787-4300 FAX: (309) 787-4397
Illinois	Onan Branch	Cummins Gateway, Inc. #1 Extra Mile Drive Collinsville, IL 62234 Telephone: (618) 345-0123 FAX: (314) 531-6604
Indiana	Indianapolis Distributor	Cummins Mid-States Power, Inc. P.O. Box 42917 3762 West Morris Street Indianapolis, IN 46242-0917 Telephone: (317) 243-7979 FAX: (317) 240-1925
Indiana	Evansville - (Branch of Louisville)	Cummins Cumberland, Inc. 7901 Highway 41 North Evansville, IN 47711 Telephone: (812) 867-4400 FAX: (812) 421-3282
Indiana	Ft. Wayne Branch	Cummins Mid-States Power, Inc. 3415 Coliseum Blvd. West (At Jct. I-69 & 30/33) Ft. Wayne, IN 46808 Telephone: (219) 482-3691 FAX: (219) 484-8930

Indiana	Gary - (Branch of Chicago)	Cummins Northern Illinois, Inc. 1440 Texas Street Gary, IN 46402 Telephone: (219) 885-5591 FAX: (219) 883-4817
Indiana	Indianapolis Branch	Cummins Mid-States Power, Inc. P. O. Box 42917 3621 West Morris Street Indianapolis, IN 46242-0917 Telephone: (317) 244-7251 FAX: (317) 240-1215
Indiana	Onan Branch	Mid-States Power, Inc. 4301 W. Morris Street P.O. Box 42917 Indianapolis, IN 46240-0917 Telephone: (317) 240-1967 FAX: (317) 240-1975
Iowa	Cedar Rapids - (Branch of Omaha)	Cummins Great Plains Diesel, Inc. 625 - 33rd Avenue SW Cedar Rapids, IA 52406 Telephone: (319) 366-7537 (24 hours) FAX: (319) 366-7562
Iowa	Des Moines - (Branch of Omaha)	Cummins Great Plains Diesel, Inc. 1680 N.E. 51st Avenue P.O. Box B Des Moines, IA 50313 Telephone: (515) 262-9591 Parts: (515) 262-9744 FAX: (515) 262-0626
Iowa	Des Moines - (Branch of Omaha)	Midwestern Power Products Division of Cummins Great Plains Diesel, Inc. 5194 N.E. 17th Street Des Moines, IA 50313 Telephone: (515) 264-1650 FAX: (515) 264-1651
Kansas	Colby - (Branch of Kansas City, Missouri)	Cummins Mid-America, LLC. 1880 South Range Colby, KS 67701 Telephone: (785) 462-3945 FAX: (785) 462-3970
Kansas	Garden City - (Branch of Kansas City, Missouri)	Cummins Mid-America, Inc. 1285 Acraway Garden City, KS 67846 Telephone: (316) 275-2277 FAX: (316) 275-2533
Kansas	Wichita - (Branch of Kansas City, Missouri)	Cummins Mid-America, Inc. 5101 North Broadway Wichita, KS 67201 Telephone: (316) 838-0875 FAX: (316) 838-0704

Kentucky	Louisville Distributor	Cummins Cumberland, Inc. (Corporate Office) 2301 Nelsonville Parkway Louisville, KY 40223 Telephone: (502) 254-3363 FAX: (502) 254-9272
Kentucky	Hazard Branch	Cummins Cumberland, Inc. Highway 15 South P.O. Box 510 Hazard, KY 41701 Telephone: (606) 436-5718 FAX: (606) 436-5038
Kentucky	Louisville Branch	Cummins Cumberland, Inc. 9820 Bluegrass Parkway Louisville, KY 40299 Telephone: (502) 491-4263 FAX: (502) 499-0896
Louisiana	Morgan City - (Branch of Memphis)	Cummins Mid-South, Inc. Hwy. 90 East P.O. Box 1229 Amelia, LA 70340 Telephone: (504) 631-0576 FAX: (504) 631-0081
Louisiana	New Orleans - (Branch of Memphis)	Cummins Mid-South, Inc. 110 E. Airline Highway Kenner, LA 70062 Telephone: (504) 468-3535 FAX: (504) 465-3408
Maine	Bangor (Branch of Boston)	Cummins Northeast, Inc. 221 Hammond Street Bangor, ME 04401 Telephone: (207) 941-1061 FAX: (207) 945-3170
Maine	Scarborough - (Branch of Boston)	Cummins Northeast, Inc. 10 Gibson Road Scarborough, ME 04074 Telephone: (207) 883-8155 FAX: (207) 883-5526
Maryland	Baltimore Distributor	Cummins Power Systems, Inc. 1907 Parkwood Drive MD 21061 Telephone: (410) 590-8700 FAX: (410) 590-8723
Massachusetts	Boston Distributor	Cummins Northeast, Inc. 100 Allied Drive Dedham, MA 02026 Telephone: (781) 329-1750 FAX: (781) 329-4428
Massachusetts	Springfield Branch	Cummins Northeast, Inc. 177 Rocus Street Springfield, MA 01104 Telephone: (413) 737-2659 FAX: (413) 731-1082

Mexico	Tijuana - (Branch of Los Angeles)	Distribuidora Cummins De Baja Blvd. 3ra. Oeste No. 17523 Fracc. Industrial Garita de Otay C.P. 22400 Tijuana, Baja California Mexico Telephone: 011-52-66-238433 FAX: 011-52-66-238649
Michigan	Detroit (Novi) Distributor	Cummins Michigan, Inc. 41216 Vincenti Court Novi, MI 48375 Telephone: (248) 478-9700 FAX: (248) 478-1570
Michigan	Blissfield, Michigan	Diesel Fuel Systems, Inc. Subsidiary of Cummins Michigan Inc. 211 N. Jipson Street Blissfield, MI 49228 Telephone: (517) 486-4324 FAX: (517) 486-3614
Michigan	Dearborn Branch	Cummins Michigan, Inc. 3760 Wyoming Avenue Dearborn, MI 48120 Telephone: (313) 843-6200 FAX: (313) 843-6070
Michigan	Grand Rapids Branch	Cummins Michigan, Inc. 3715 Clay Avenue, S.W. Grand Rapids, MI 49508 Telephone: (616) 538-2250 FAX: (616) 538-3830
Michigan	Grand Rapids Branch	Standby Power, Inc. 7580 Expressway Drive S.W. Grand Rapids, MI 49548 Telephone: (616) 281-2211 FAX: (616) 281-3177
Michigan	Iron Mountain - (Branch of De Pere)	Cummins Great Lakes, Inc. 1901 Stevenson Avenue Iron Mountain, MI 49801 Telephone: (906) 774-2424 (800) 236-2424 FAX: (906) 774-1190
Michigan	Novi Branch	Cummins Michigan, Inc. 25100 Novi Road Novi, MI 48375 Telephone: (248) 380-4300 FAX: (248) 380-0910
Michigan	Power Products (Branch of Detroit)	Cummins Michigan, Inc. 41326 Vincenti Ct. Novi, MI 48375 Telephone: (248) 426-9300 FAX: (248) 473-8560
Michigan	Saginaw Branch	Cummins Michigan, Inc. 722 N. Outer Drive Saginaw, MI 48605 Telephone: (517) 752-5200 FAX: (517) 752-4194

Michigan	Standby Power - (Branch of Detroit)	Cummins Michigan, Inc. 12130 Dixie Redford, MI 48239 Telephone: (313) 538-0200 FAX: (313) 538-3966
Minnesota	St. Paul Distributor	Cummins North Central, Inc. 3030 Centre Pointe Drive Suite 500 Roseville, MN 55113 Telephone: (651) 636-1000 FAX: (651) 638-2442
Minnesota	Duluth Branch	Cummins Diesel Sales, Inc. 3115 Truck Center Drive Duluth, MN 55806-1786 Telephone: (218) 628-3641 FAX: (218) 628-0488
Minnesota	St. Paul Branch	Cummins North Central, Inc. 2690 Cleveland Ave. North St. Paul, MN 55113 Telephone: (651) 636-1000 FAX: (651) 638-2497
Mississippi	Jackson - (Branch of Memphis)	Cummins Mid-South, Inc. 325 New Highway 49 South Jackson, MS 39288-4224 Telephone: Admin.: (601) 932-7016 Parts: (601) 932-2720 Service: (601) 939-1800 FAX: (601) 932-7399
Missouri	Kansas City Distributor and Branch	Cummins Mid-America, Inc. 8201 NE Parvin Road Kansas City, MO 64161 Telephone: (816) 414-8200 FAX: (816) 414-8299
Missouri	Joplin Branch	Cummins Mid-America, Inc. 3507 East 20th Street Joplin, MO 64801 Telephone: (417) 623-1661 FAX: (417) 623-1817
Missouri	Springfield Branch	Cummins Mid-America, Inc. 3637 East Kearney Springfield, MO 65803 Telephone: (417) 862-0777 FAX: (417) 862-4429
Missouri	St. Louis Distributor	Cummins Gateway, Inc. 7210 Hall Street St. Louis, MO 63147 Telephone: (314) 389-5400 FAX: (314) 389-9671
Missouri	Columbia Branch	Cummins Gateway, Inc. 5221 Highway 763 North Columbia, MO 65202 Telephone: (314) 449-3711 FAX: (314) 449-3712

Missouri	Sikeston Branch	Cummins Gateway, Inc. 101 Keystone Drive Sikeston, MO 63801 Telephone: (314) 472-0303 FAX: (314) 472-0306
Missouri	Industrial Power Branch	Cummins Gateway, Inc. 3256 E. Outer Road Scott City, MO 63788 Telephone: (573) 335-9399 FAX: (573) 335-7062
Montana	Billings - (Branch of Denver)	Cummins Rocky Mountain, Inc. 5151 Midland Road Billings, MT 59101 Telephone: (406) 245-4194 FAX: (406) 245-7923
Montana	Great Falls - (Branch of Denver)	Cummins Rocky Mountain, Inc. 415 Vaughn Road Great Falls, MT 59404 Telephone: (406) 452-8561 FAX: (406) 452-9911
Montana	Missoula - (Branch of Seattle)	Cummins Northwest, Inc. 4950 North Reserve Street Missoula, MT 59802-1498 Telephone: (406) 728-1300 FAX: (406) 728-8523
Nebraska	Omaha Distributor and Branch	Cummins Great Plains Diesel, Inc. 5515 Center Street P.O. Box 6068 Omaha, NE 68106 Telephone: (402) 551-7678 (24 Hours) FAX: (402) 551-1952
Nebraska	Kearney Branch	Cummins Great Plains Diesel, Inc. 515 Central Avenue Kearney, NE 68847 Telephone: (308) 234-1994 FAX: (308) 234-5776
Nevada	Elko - (Branch of Salt Lake City)	Cummins Intermountain, Inc. 5370 East Idaho Street Elko, NV 89801 Telephone: (775) 738-6405 FAX: (775) 738-1719
Nevada	Las Vegas - (Branch of Salt Lake City)	Cummins Intermountain, Inc. 2750 Losee Road North Las Vegas, NV 89030 Telephone: (702) 399-2339 FAX: (702) 399-7457
Nevada	Sparks - (Branch of Salt Lake City)	Cummins Intermountain, Inc. 150 Glendale Avenue Sparks, NV 89431 Telephone: (775) 331-4983 FAX: (775) 331-7429

New Jersey	Newark - (Branch of Bronx)	Cummins Metropower, Inc. 41-85 Doremus Ave. Newark, NJ 07105 Telephone: (973) 491-0100 FAX: (973) 578-8873
New Mexico	Albuquerque - (Branch of Phoenix)	Cummins Southwest, Inc. 1921 Broadway N.E. Albuquerque, NM 87102 Telephone: (505) 247-2441 FAX: (505) 842-0436
New Mexico	Farmington - (Branch of Phoenix)	Cummins Southwest, Inc. 1101 North Troy King Road Farmington, NM 87401 Telephone: (505) 327-7331 FAX: (505) 326-2948
New York	Ex Distributor	Cummins Metropower, Inc. 890 Zerega Avenue Bronx, NY 10473 Telephone: (718) 892-2400 FAX: (718) 892-0055
New York	Albany - (Branch of Boston)	Cummins Northeast, Inc. 101 Railroad Avenue Albany, NY 12205 Telephone: (518) 459-1710 FAX: (518) 459-7815
New York	Williamsville - (Branch of Boston)	Cummins Northeast, Inc. 480 Lawrence Bell Dr. Williamsville, NY 14221-7090 Telephone: (716) 631-3211 FAX: (716) 626-0799
New York	Syracuse - (Branch of Albany)	Cummins Northeast, Inc. 29 Eastern Avenue Syracuse, NY 13211 Telephone: (315) 437-2751 FAX: (315) 437-8141
North Carolina	Charlotte Distributor	Cummins Atlantic, Inc. 11101 Nations Ford Road (28273) P.O. Box 240729 Charlotte, NC 28224-0729 Telephone: (704) 588-1240 FAX: (704) 587-4870
North Carolina	Charlotte Branch	Cummins Atlantic, Inc. 3700 North Interstate 85 Charlotte, NC 28206 Telephone: (704) 596-7690 FAX: (704) 596-3038
North Carolina	Greensboro Branch	Cummins Atlantic, Inc. 513 Preddy Boulevard (27406) P.O. Box 22066 Greensboro, NC 27420-2066 Telephone: (336) 275-4531 FAX: (336) 275-8304

North Carolina	Wilson Branch	Cummins Atlantic, Inc. 1514 Cargill Avenue (27893) P.O. Box 1177 Wilson, NC 27894-1117 Telephone: (252) 237-9111 FAX: (252) 237-9132
North Dakota	Fargo - (Branch of St. Paul)	Cummins North Central, Inc. 3801 - 34th Ave. SW Fargo, ND 58104 Telephone: (701) 282-2466 FAX: (701) 277-5399
North Dakota	Grand Forks - (Branch of St. Paul)	Cummins North Central, Inc. 4728 Gateway Drive Grand Forks, ND 58201 Telephone: (701) 775-8197 FAX: (701) 775-4833
North Dakota	Minot - (Branch of St. Paul)	Cummins North Central, Inc. 1501 - 20th Avenue, S.E. Minot, ND 58702 Telephone: (701) 852-3585 FAX: (701) 852-3588
Ohio	Columbus Distributor and Branch	Cummins Interstate Power, Inc. 4000 Lyman Drive Hilliard (Columbus), OH 43026 Telephone: (614) 771-1000 FAX: (614) 771-0769
Ohio	Columbus Distributor	Cummins Interstate Power, Inc. 2297 Southwest Blvd., Suite K Grove City, OH 43123 Telephone: (614) 771-1000 FAX: (614) 527-2576
Ohio	Cincinnati Branch	Cummins Interstate Power, Inc. 10470 Evendale Drive Cincinnati, OH 45241 Telephone: (513) 563-6670 FAX: (513) 563-0594
Ohio	Cleveland Branch	Cummins Interstate Power, Inc. 7585 Northfield Road Cleveland, OH 44146 Telephone: (440) 439-6800 FAX: (440) 439-7390
Ohio	Strasburg Branch	Cummins Interstate Power, Inc. 777 South Wooster Avenue Strasburg, OH 44680 Telephone: (216) 878-5511 FAX: (216) 878-7666
Ohio	Toledo Branch	Cummins Interstate Power, Inc. 801 Illinois Avenue Maumee (Toledo), OH 43537 Telephone: (419) 893-8711 FAX: (419) 893-5362

Ohio	Youngstown Branch	Cummins Interstate Power, Inc. 7145 Masury Road Hubbard (Youngstown), OH 44425 Telephone: (216) 534-1935 FAX: (216) 534-5606
Oklahoma	Oklahoma City - (Branch of Arlington)	Cummins Southern Plains, Inc. 5800 West Reno Oklahoma City, OK 73127 Telephone: (405) 946-4481 (24 hours) FAX: (405) 946-3336
Oklahoma	Tulsa - (Branch of Arlington)	Cummins Southern Plains, Inc. 16525 East Skelly Drive Tulsa, OK 74116 Telephone: (918) 234-3240 FAX: (918) 234-2342
Oregon	Bend - (Branch of Seattle)	Cummins Northwest, Inc. 3500 N. Highway 97 (97701-5729) P.O. Box 309 Bend, OR 97709-0309 Telephone: (541) 389-1900 FAX: (541) 389-1909
Oregon	Coburg/Eugene - (Branch of Seattle)	Cummins Northwest, Inc. 91201 Industrial Parkway Coburg, OR 97401 (Mailing Address) P.O. Box 10877 Eugene, OR 97440-2887 Telephone: (541) 687-0000 FAX: (541) 687-1977
Oregon	Medford - (Branch of Seattle)	Cummins Northwest, Inc. 4045 Crater Lake Highway Medford, OR 97504-9796 Telephone: (541) 779-0151 FAX: (541) 772-2395
Oregon	Pendleton - (Branch of Seattle)	Cummins Northwest, Inc. 223 S.W. 23rd Street Pendleton, OR 97801-1810 Telephone: (541) 276-2561 FAX: (541) 276-2564
Oregon	Portland - (Branch of Seattle)	Cummins Northwest, Inc. 4711 N. Basin Avenue P. O. Box 2710 (97208-2710) Portland, OR 97217-3557 Telephone: (503) 289-0900 FAX: (503) 286-5938
Pennsylvania	Philadelphia Distributor	Cummins Power Systems, Inc. 2727 Ford Road Bristol, PA 19007 Telephone: (215) 785-6005 and (609) 563-0005 FAX: (215) 785-4085

Pennsylvania	Bristol Branch	Cummins Power Systems, Inc. 2727 Ford Road Bristol, PA 19007 Telephone: (215) 785-6005 and (609) 563-0005 FAX: (215) 785-4728
Pennsylvania	Pittsburgh Branch	Cummins Power Systems, Inc. 3 Alpha Drive Pittsburgh, PA 15238-2901 Telephone: (412) 820-8300 FAX: (412) 820-8308
Pennsylvania	Harrisburg Branch	Cummins Power Systems, Inc. 4499 Lewis Road Harrisburg, PA 17111-2541 Telephone: (717) 564-1344 FAX: (717) 558-8217
Puerto Rico	Puerto Nuevo - (Branch of Tampa)	Cummins Diesel Power, Inc. #31 Calle "C" El Matadero Puerto Nuevo, Puerto Rico 00920 Telephone: (787) 793-0300 FAX: (787) 793-1072
South Carolina	Charleston - (Branch of Charlotte)	Cummins Atlantic, Inc. 3028 West Montague Avenue Charleston, SC 29418-5593 Telephone: (843) 554-5112 FAX: (843) 745-0745
South Carolina	Charleston - (Branch of Charlotte)	Cummins Atlantic Inc. 231 Farmington Road Charleston, SC 29483 Telephone: (843) 851-9819 FAX: (843) 875-4338
South Carolina	Columbia - (Branch of Charlotte)	Cummins Atlantic, Inc. 1233 Bluff Road (29201) P.O. Box 13543 Columbia, SC 29201-3543 Telephone: (803) 799-2410 FAX: (803) 779-3427
South Dakota	Sioux Falls - (Branch of Omaha)	Cummins Great Plains Diesel, Inc. 701 East 54th Street North Sioux Falls, SD 57104 Telephone: (605) 336-1715 FAX: (605) 336-1748
Tennessee	Memphis Distributor & Distribution Center	Cummins Mid-South, Inc. 666 Riverside Drive Memphis, TN 38703 Telephone: (901) 577-0666 FAX: (901) 522-8758
Tennessee	Chattanooga - (Branch of Atlanta)	Cummins South, Inc. 1509 East 26th Street Chattanooga, TN 37407-1095 Telephone: (615) 629-1447 FAX: (615) 629-1494

Tennessee	Knoxville - (Branch of Louisville)	Cummins Cumberland, Inc. 1211 Ault Road Knoxville, TN 37914 Telephone: (423) 523-0446 FAX: (423) 523-0343
Tennessee	Memphis Branch	Cummins Mid-South, Inc. 1784 E. Brooks Road Memphis, TN 38116 Telephone: Sales/Admin.: (901) 345-7424 Parts: (901) 345-1784 Service: (901) 345-6185 FAX: (901) 346-4735
Tennessee	Nashville - (Branch of Louisville)	Cummins Cumberland, Inc. 706 Spence Lane Nashville, TN 37217 Telephone: (615) 366-4341 FAX: (615) 366-5693
Texas	Arlington Distributor	Cummins Southern Plains, Inc. 600 N Watson Road Arlington, TX 76004-3027 Telephone: (817) 640-6801 FAX: (817) 640-6852
Texas	Amarillo Branch	Cummins Southern Plains, Inc. 5224 Interstate 40 - Expressway East P.O. Box 31570 Amarillo, TX 79120-1570 Telephone: (806) 373-3793 (24 hours) FAX: (806) 372-8547
Texas	Dallas Branch	Cummins Southern Plains, Inc. 3707 Irving Boulevard Dallas, TX 75247 Telephone: (214) 631-6400 (24 hours) FAX: (214) 631-2322
Texas	El Paso - (Branch of Phoenix)	Cummins Southwest, Inc. 14333 Gateway West El Paso, TX 79927 Telephone: (915) 852-4200 FAX: (915) 852-3295
Texas	Fort Worth Branch	Cummins Southern Plains, Inc. 3250 North Freeway Fort Worth, TX 76111 Telephone: (817) 624-2107 (24 hours) FAX: (817) 624-3296
Texas	Houston Branch	Cummins Southern Plains, Inc. 4750 Homestead Road P.O. Box 1367 Houston, TX 77251-1367 Telephone: (713) 675-7421 (24 hours) FAX: (713) 675-1515

Texas	Mesquite Branch	Cummins Southern Plains, Inc. 2615 Big Town Blvd. Mesquite, TX 75150 Telephone: (214) 321-5555 (24 hours) FAX: (214) 328-2732
Texas	Odessa Branch	Cummins Southern Plains, Inc. 1210 South Grandview P.O. Box 633 Odessa, TX 79760-0633 Telephone: (915) 332-9121 (24 hours) FAX: (915) 333-4655
Texas	San Antonio Branch	Cummins Southern Plains, Inc. 6226 Pan Am Expressway North P.O. Box 18385 San Antonio, TX 78218-0385 Telephone: (512) 655-5420 (24 hours) FAX: (512) 655-3865
Texas	Houston Onan Branch	Southern Plains Power A Division of Cummins Southern Plains 1155 West Loop North Houston, TX 77055 Telephone: (713) 956-0020 FAX: (713) 956-0266
Utah	Salt Lake City Distributor	Cummins Intermountain, Inc. 1030 South 300 West Salt Lake City, UT 84101 Telephone: (801) 355-6500 FAX: (801) 524-1351
Utah	Vernal Branch	Cummins Intermountain, Inc. 1435 East 335 South Vernal, UT 84078 Telephone: (435) 789-5732 FAX: (435) 789-2853
Virginia	Cloverdale - (Branch of Charlotte)	Cummins Atlantic, Inc. 263 Simmons Drive Cloverdale, VA 24077 Telephone: (540) 966-3169 FAX: (540) 966-3749
Virginia	Richmond - (Branch of Charlotte)	Cummins Atlantic, Inc. 3900 Deepwater Terminal Road Richmond, VA 23234 Telephone: (804) 232-7891 FAX: (804) 232-7428
Virginia	Tidewater - (Branch of Charlotte)	Cummins Atlantic, Inc. Atlantic Power Generation 3729 Holland Blvd. Chesapeake, VA 23323 Telephone: (757) 485-4848 FAX: (757) 485-5085
Washington	Seattle Distributor	Cummins Northwest, Inc. 811 S.W. Grady Way (98055-2944) P.O. Box 9811 Renton, WA 98057-9811 Telephone: (425) 235-3400 FAX: (425) 235-8202

Washington	Chehalis Branch	Cummins Northwest, Inc. 926 N.W. Maryland Chehalis, WA 98532-0339 Telephone: (360) 748-8841 FAX: (360) 748-8843
Washington	Spokane Branch	Cummins Northwest, Inc. 11134 W. Westbow Blvd. Spokane, WA 99204 Telephone: (509) 455-4411 FAX: (509) 624-4681
Washington	Tacoma Branch	Cummins Northwest, Inc. 3701 Pacific Highway East Tacoma, WA 98424-1135 Telephone: (253) 922-2191 FAX: (253) 922-2379
Washington	Yakima Branch	Cummins Northwest, Inc. 1905 East Central Avenue (98901-3609) P.O. Box 9129 Yakima, WA 98909-0129 Telephone: (509) 248-9033 FAX: (509) 248-9035
West Virginia	Charleston - (Branch of Louisville)	Cummins Cumberland, Inc. 3100 MacCorkle Ave. SW P.O. Box 8456 South Charleston, WV 25303 Telephone: (304) 744-6373 FAX: (304) 744-8605
West Virginia	Fairmont - (Branch of Louisville)	Cummins Cumberland, Inc. South Fairmount Exit, I-79 145 Middletown Road Fairmont, WV 26554 Telephone: (304) 367-0196 FAX: (304) 367-1077
Wisconsin	DePere Distributor	Cummins Great Lakes, Inc. Corporate Office 875 Lawrence Drive P.O. Box 5070 DePere, WI 54115-5070 Telephone: (920) 337-1991 FAX: (920) 337-9746
Wisconsin	Chippewa Falls Branch	Cummins Great Lakes, Inc. 2030 St. Highway 53 Chippewa Falls, WI 54729 Telephone: (715) 720-0680 FAX: (715) 720-0685
Wisconsin	DePere Branch	Cummins Great Lakes, Inc. 939 Lawrence Drive P. O. Box 5070 DePere, WI 54115-5070 Telephone: (920) 336-9631 (800) 236-1191 FAX: (920) 336-8984

Wisconsin	Milwaukee Branch	Cummins Great Lakes, Inc. 9401 South 13th Street P.O. Box D Oak Creek, WI 53154 Telephone: (414) 768-7400 (800) 472-8283 FAX: (414) 768-9441
Wisconsin	Wausau Branch	Cummins Great Lakes, Inc. 4703 Rib Mountain Drive Wausau, WI 54401 Telephone: (715) 359-6888 (800) 236-3744 FAX: (715) 359-3744
Wyoming	Gillette - (Branch of Denver)	Cummins Rocky Mountain, Inc. 2700 Hwy. 14 & 16 North P.O. Box 1207 (82717) Gillette, WY 82716 Telephone: (307) 682-9611 FAX: (307) 682-8242
Wyoming	Rock Springs - (Branch of Salt Lake City)	Cummins Intermountain, Inc. 2000 Foothill Blvd. P.O. Box 1634 Rock Springs, WY 82901 Telephone: (307) 362-5168 FAX: (307) 362-5171

Distributors and Branches - Canada

Alberta	Edmonton Distributor and Branch	Cummins Alberta 11751 - 181 Street Edmonton, AB T5S 2K5 Telephone: (780) 455-2151 FAX: (780) 454-9512
Alberta	Calgary Branch	Cummins Alberta 4887 - 35th Street S.E. Calgary, Alberta T2B 3H6, Canada Telephone: (403) 569-1122 FAX: (403) 569-0027
Alberta	Grande Prairie	Cummins Alberta - Grande Praire RR2, Site 9, Box 22 Sexsmith, AB CN T0H 3C0 Telephone: (780) 568-3359 FAX: (780) 568-2263
Alberta	Hinton Branch	Cummins Alberta 135 Veats Avenue Hinton, Alberta T7V 1S8, Canada Telephone: (780) 865-5111 FAX: (780) 865-5714
Alberta	Lethbridge Branch	Cummins Alberta 240 - 24th Street North Lethbridge, Alberta T1H 3T8, Canada Telephone: (403) 329-6144 FAX: (403) 320-5383
British Columbia	Vancouver Distributor	Cummins British Columbia 18452 - 96th Avenue Surrey, B.C., Canada V4N 3P8 Telephone: (604) 882-5000 FAX: (604) 882-5080
British Columbia	Kamloops Branch	Cummins British Columbia 976 Laval Crescent Kamloops, B.C. Canada V2C 5P5 Telephone: (250) 828-2388 FAX: (250) 828-6713
British Columbia	Prince George Branch	Cummins British Columbia 102- 3851- 18th Avenue Prince George, B.C. V2N 1B1 Telephone: (250) 564-9111 FAX: (250) 564-5853
British Columbia	Sparwood Branch	Cummins British Columbia 731 Douglas Fir Road Sparwood, B.C. VOB 2G0, Canada Telephone: (250) 425-0522 FAX: (250) 425-0323
British Columbia	Tumbler Ridge Branch	Cummins British Columbia Industrial Site, Box 226 Tumbler Ridge, B.C. Canada VOC 2W0 Telephone: (250) 242-4217 FAX: (250) 242-4906

Manitoba	Winnipeg Distributor	Cummins Mid-Canada Ltd. 489 Oak Point Road P.O. Box 1860 Winnipeg, MB R3C 3R1, Canada Telephone: (204) 632-5470 FAX: (204) 697-0267
New Brunswick	Fredericton - (Branch of Montreal)	Cummins Eastern Canada, Inc. R.R.#1 Doak Road P.O. Box 1178, Station 'A' Fredericton, New Brunswick E3B 4X2, Canada Telephone: (506) 451-1929 FAX: (506) 451-1921
Newfoundland	St. John's - (Branch of Montreal)	Cummins Eastern Canada, Inc. 122 Clyde Avenue Donovans Industrial Park Mount Pearl, Newfoundland A1N 2C2 Canada Telephone: (709) 747-0176 FAX: (709) 747-2283
Newfoundland	Wabush - (Branch of Montreal)	Cummins Eastern Canada, Inc. Wabush Industrial Park Wabush, Newfoundland A0R 1B0 Telephone: (709) 282-3626 FAX: (709) 282-3108
Nova Scotia	Halifax - (Branch of Montreal)	Cummins Eastern Canada, Inc. 50 Simmonds Drive Dartmouth, Nova Scotia B3B 1R3 Telephone: (902) 468-7938 FAX: (902) 468-5177 Parts: (902) 468-6560
Ontario	Toronto Distributor	Cummins Ontario, Inc. 7175 Pacific Circle Mississauga, ON L5T 2A5 Telephone: (905) 795-0050 FAX: (905) 795-0021
Ontario	Kenora - (Branch of Winnipeg)	Cummins Mid-Canada Ltd. Highway 17 East P.O. Box 8 Kenora, Ontario P9N 3X1 Telephone: (807) 548-1941 FAX: (807) 548-8302
Ontario	Ottawa Branch	Cummins Ontario Inc. 3189 Swansea Crescent Ottawa, Ontario K1G 3W5, Telephone: (613) 736-1146 FAX: (613) 736-1202
Ontario	Thunder Bay Branch	Cummins Ontario Inc. 1400 W. Walsh Street Thunder Bay Ontario P7E 4X4 Telephone: (807) 577-7561 FAX: (807) 577-1727

Ontario	Whitby Branch	Cummins Ontario Inc. 1311 Hopkins Street Whitby, Ontario L1N 2C2, Canada Telephone: (905) 668-6886 FAX: (905) 668-1375
Quebec	Montreal Distributor	Cummins Eastern Canada, Inc. 7200 Trans Canada Highway Pointe Claire, Quebec H9R 1C2, Telephone: (514) 695-8410 FAX: (514) 695-8917
Quebec	Montreal Branch	Cummins Eastern Canada, Inc. 7200 Trans Canada Highway Pointe Claire, Quebec H9R 1C2, Canada Telephone: (514) 695-8410 Sales: (514) 695-4555 Parts: (514) 694-5880 FAX: (514) 695-8917
Quebec	Dorval Onan Branch	Cummins, Eastern Canada, Inc. 580 Lepihe Dorval, Quebec H9H 1G2 Telephone: (514) 631-5000 FAX: (514) 631-0104
Quebec	Quebec City Branch	Cummins Diesel Branch of Cummins Americas, Inc. 2575 Dalton Street Ste. Foy, Quebec G1P 3S7 Telephone: (418) 653-6411 FAX: (418) 653-5844
Quebec	Val D'Or Branch	Cummins, Eastern Canada, Inc. 1025 Rue Del Val D'Or, Quebec 59P 4P6 Telephone: (819) 825-0993 FAX: (819) 825-8488
Saskatchewan	Lloydminster - (Branch of Winnipeg)	Cummins Mid-Canada Ltd. 4005 52nd Lloydminster, SK S9V 0Y9 Telephone: (305) 825-2062 FAX: (305) 825-6702
Saskatchewan	Regina - (Branch of Winnipeg)	Cummins Mid-Canada Ltd. 110 Kress Street P.O. Box 98 Regina, SK S4P 2Z5 Telephone: (306) 721-9710 FAX: (306) 721-2962
Saskatchewan	Saskatoon - (Branch of Winnipeg)	Cummins Mid-Canada, Ltd. 3001 Faithful Avenue P.O. Box 7679 Saskatoon, SK S7K 4R4, Canada Telephone: (306) 933-4022 FAX: (306) 242-1722

Distributors and Branches - Australia

Branches:	Gepps Cross	Cummins Engine Company, Pty. Ltd. P.O. Box 108 Blair Athol, 5084 South Australia, Australia Location: 45-49 Cavan Road Gepps Cross, 5094 Telephone: (61-8) 8262-5211
Branches:	Dosra	Cummins Engine Company, Pty. Ltd. P.O. Box 124 Darra, 4076 Queensland, Australia Location: 33 Kimberley Street Darra, 4076, Australia Telephone: (61-7) 3375-3277
Branches:	Bunbury	Cummins Engine Company, Pty. Ltd. P.O. Box 1751 Bunbury, WA 6230 Australia Location: 11 Dryanda Court Picton, WA 6230 Telephone: (61-8) 9725-6777 FAX: (61-8) 9725-6444
Branches:	Cairns	Cummins Engine Company, Pty. Ltd. P.O. Box 7189 Cairns Mail Centre, 4870 Queensland, Australia Location: Liberty Street Cairns, 4870 Telephone: (61-7) 935-2999
Branches:	Campbellfield	Cummins Engine Company, Pty. Ltd. Private Bag 9 Campbellfield, 3061 Victoria, Australia Location: 1788-1800 Hume Highway Campbellfield, 3061 Telephone: (613) 9357-9200
Branches:	Dandenong	Cummins Engine Company, Pty. Ltd. Lot 7 Greens Road Dandenong, 3175 Victoria, Australia Telephone: (613) 9706-8088
Branches:	Darwin	Cummins Engine Company, Pty. Ltd. P.O. Box 37587 Winnellie, 0821 Northern Territory, Australia Location: Lot 1758 Graffin Crescent Winnellie, 0821 Telephone: (61-8) 8947-0766

<p>Branches:</p>	<p>Devonport</p>	<p>Cummins Engine Company, Pty. Ltd. P.O. Box 72E Tasmania, Australia Location: 2 Matthews Way Devonport, 7310 Telephone: (61-3) 6424-8800</p>
<p>Branches:</p>	<p>Emerald</p>	<p>Cummins Engine Company, Pty. Ltd. P.O. Box 668 Emerald, 4720 Queensland, Australia Location: Capricorn Highway Emerald, 4720 Telephone: (61-7) 4982-4022</p>
<p>Branches:</p>	<p>Grafton</p>	<p>Cummins Engine Company, Pty. Ltd. P.O. Box 18 South Grafton, 2461 New South Wales, Australia Location: 18-20 Induna Street South Grafton, 2461 Telephone: (61-2) 6642-3655</p>
<p>Branches:</p>	<p>Hexham</p>	<p>Cummins Engine Company, Pty. Ltd. 21 Galleghan Street Hexham New South Wales, Australia Telephone: (61-2) 4964-8466 FAX: (61-2) 4964-8616</p>
<p>Branches:</p>	<p>Kalgoorlie</p>	<p>Cummins Engine Company, Pty. Ltd. P.O. Box 706 Kalgoorlie, 6430 Western Australia, Australia Location: 16 Atbara Street Kalgoorlie, 6430 Telephone: (61-8) 9021-2588</p>
<p>Branches:</p>	<p>Karratha</p>	<p>Cummins Engine Company, Pty. Ltd. P.O. Box 377 Karratha, WA 6714 Australia Location: 1490 Lambert Road Karratha, WA 6714 Australia Telephone: (61-8) 9144-4646 FAX: (61-8) 9143-1507</p>
<p>Branches:</p>	<p>Laverton</p>	<p>Cummins Engine Company, Pty. Ltd. Locked Bag 1 Laverton, Victoria 3028 Australia Location: 195 Boundary Road Laverton North, Victoria 3028 Australia Telephone: (61-3) 9360-0800 FAX: (61-3) 9360-0438</p>

<p>Branches:</p>	<p>Leeton</p>	<p>Cummins Engine Company, Pty. Ltd. P.O. Box 775 Leeton, NSW 2705 Australia Location: 29 Brady Way Leeton, NSW 2705 Australia Telephone: (61-2) 6953-3077 FAX: (61-2) 6953-3109</p>
<p>Branches:</p>	<p>Mackay</p>	<p>Cummins Engine Company, Pty. Ltd. P.O. Box 842 Mackay, 4740 Queensland, Australia Location: 4 Presto Avenue Mackay, 4746 Telephone: (61-7) 4955-1222</p>
<p>Branches:</p>	<p>Mount Gambier</p>	<p>Cummins Engine Company, Pty. Ltd. P.O. Box 2219 Mount Gambier, 5290 South Australia, Australia Location: 2 Avey Road Mount Gambier, 5290 Telephone: (61-87) 25-6422</p>
<p>Branches:</p>	<p>Penrith</p>	<p>Cummins Engine Company, Pty. Ltd. P.O. Box 132 Cambridge Park, 2747 New South Wales, Australia Location: 7 Andrews Road Penrith, 2750 Telephone: (61-2) 4729-1313</p>
<p>Branches:</p>	<p>Queanbeyan</p>	<p>Cummins Engine Company, Pty. Ltd. P.O. Box 527 Queanbeyan, 2620 New South Wales, Australia Location: 15-27 Bayldon Road Queanbeyan, 2620 Telephone: (61-2) 6297-3433 FAX: (61-2) 6297-6709</p>
<p>Branches:</p>	<p>Regency Park</p>	<p>Cummins Engine Company, Pty. Ltd. P.O. Box 2147 Regency Park, SA 5942 Australia Location: 11 Manton Street Hindmarsh, SA 5942 Australia Telephone: (61-8) 8346-3832 FAX: (61-8) 8340-2045</p>

Branches:	Swan Hill	Cummins Engine Company, Pty. Ltd. P.O. Box 1264 Swan Hill, 3585 Victoria, Australia Location: 5 McAllister Road Swan Hill, 3585 Telephone: (61-3) 5032-1511
Branches:	Tamworth	Cummins Engine Company, Pty. Ltd. P.O. Box 677 Tamworth, 2320 New South Wales, Australia Location: Lot 65 Gunnedah Road Tamworth, 2340 Telephone: (61-2) 6765-5455
Branches:	Townsville	Cummins Engine Company, Pty. Ltd. P.O. Box 7339 Garbutt Business Centre, QLD4814 Australia Location: 704-710 Ingham Road Townsville, QLD 4814 Telephone: (61-7) 4774-7733 FAX: (61-7) 4774-7640
Branches:	Welshpool	Cummins Engine Company, Pty. Ltd. P. O. Box 52 Welshpool, 6986 Western Australia, Australia Location: 50 Kewdale Road Welshpool, 6106 Telephone: (61-8) 9458-5911
Branches:	Wetherill Park	Cummins Engine Company, Pty. Ltd. Private Bag 150 Wetherill Park, NSW 2164 Australia Location: 492-494 Victoria Street Wetherill Park, NSW 2164 Australia Telephone: (61-2) 9616-5300 FAX: (61-2) 9616-5399
Branches:	Wodonga	Cummins Engine Company, Pty. Ltd. P.O. Box 174 Wodonga, 3690 Victoria, Australia Location: 9-11 McKoy Street Wodonga, 3690 Telephone: (61-2) 6024-3655

Distributors and Branches - New Zealand

Auckland		Cummins Engine Company, Pty. Ltd. Private Bag 92804 Penrose, Auckland, New Zealand Location: 440 Church Street Penrose Telephone: (64-9) 579-0085
Branches:	Auckland	Cummins Engine Company, Pty. Ltd. Private Bag 92804 Penrose, Auckland, New Zealand Location: 440 Church Street Penrose Telephone: (64-9) 579-0085
Branches:	Christchurch	Cummins Engine Company, Pty. Ltd. P.O. Box 16-149 Hornby, Christchurch, New Zealand Location: 35 Parkhouse Road Sockburn, Christchurch Telephone: (64-3) 348-8170
Branches:	Dunedin	Cummins Engine Company, Pty. Ltd. P.O. Box 2333 South Dunedin, New Zealand Location: 8 Devon Street Dunedin Telephone: (643) 477-8818
Branches:	Palmerston North	Cummins Engine Company, Pty. Ltd. P.O. Box 9024 Palmerston North, New Zealand Location: 852-860 Tremain Avenue Telephone: (64-6) 356-2209
Branches:	Rotorua	Cummins Engine Company, Pty. Ltd. P.O. Box 934 Rotorua, New Zealand Location: 328 Te Ngae Road Rotorua Telephone: (647) 345-6699

Regional Offices - International - Locations

European Regional Office - Mechelen																			
<p>Cummins Diesel N.V. Blarenberglaan 4 Industriepark Noord 2 2800 Mechelen Brussels Telephone: (32-15) 89000</p>																			
<p>Countries Covered:</p> <table style="width: 100%; border: none;"> <tr> <td style="width: 33%;">Austria</td> <td style="width: 33%;">Luxembourg</td> </tr> <tr> <td>Belgium</td> <td>Netherlands</td> </tr> <tr> <td>Czech Republic</td> <td>Norway</td> </tr> <tr> <td>Denmark</td> <td>Portugal</td> </tr> <tr> <td>Finland</td> <td>Slovakia</td> </tr> <tr> <td>Greece</td> <td>Spain</td> </tr> <tr> <td>Hungary</td> <td>Sweden</td> </tr> <tr> <td>Iceland</td> <td>Switzerland</td> </tr> <tr> <td>Israel</td> <td></td> </tr> </table>		Austria	Luxembourg	Belgium	Netherlands	Czech Republic	Norway	Denmark	Portugal	Finland	Slovakia	Greece	Spain	Hungary	Sweden	Iceland	Switzerland	Israel	
Austria	Luxembourg																		
Belgium	Netherlands																		
Czech Republic	Norway																		
Denmark	Portugal																		
Finland	Slovakia																		
Greece	Spain																		
Hungary	Sweden																		
Iceland	Switzerland																		
Israel																			

Cumbrasa Regional Office - Brazil	
<p>Cummins Brasil S.A. Rua Jati, 266 07180-900 Guarulhos Sao Paulo, Brazil</p>	<p>Mailing Address: P.O. Box 13 07180-900 Guarulhos Sao Paulo, Brazil Telephone: (55-11) 945-9811</p>
<p>Country Covered: Brazil</p>	

Beijing Regional Office - China	
<p>Cummins Corporation China World Tower, Suite 917 China World Trade Center No. 1 Jian Guo Men Wai Beijing 100004 People's Republic of China Telephone: (86-1) 6505-1658 Fax: (88-10) 6505-4211</p>	
<p>Countries Covered: China Mongolia</p>	

Bogota Regional Office - Columbia									
Cummins Engine Co. de Colombia S.A. Carrera 11A No. 90-15 Of. 601/602 Bogota, D.E., Colombia Telephone: (57-1) 610-4849	Mailing Address: Apartado Aereo 90988 Bogota D.E., Colombia								
Countries Covered: <table style="width: 100%; border: none;"> <tr> <td style="width: 50%;">Argentina</td> <td style="width: 50%;">Ecuador</td> </tr> <tr> <td>Bolivia</td> <td>Paraguay</td> </tr> <tr> <td>Chile</td> <td>Peru</td> </tr> <tr> <td>Colombia</td> <td>Uruguay</td> </tr> </table>		Argentina	Ecuador	Bolivia	Paraguay	Chile	Peru	Colombia	Uruguay
Argentina	Ecuador								
Bolivia	Paraguay								
Chile	Peru								
Colombia	Uruguay								

Gross-Gerau Regional Office - Germany															
Cummins Diesel Deutschland GmbH Odenwaldstr. 23 D-4521 Gross-Gerau Germany Telephone: (49-6152) 174-0															
Countries Covered: <table style="width: 100%; border: none;"> <tr> <td style="width: 50%;">Albania</td> <td style="width: 50%;">Poland</td> </tr> <tr> <td>Bulgaria</td> <td>Romania</td> </tr> <tr> <td>Latvia</td> <td>Lithuania</td> </tr> <tr> <td>Germany</td> <td>Estonia</td> </tr> <tr> <td>Luxembourg</td> <td>Croatia</td> </tr> <tr> <td>Slovenia</td> <td>Bosnia</td> </tr> <tr> <td>Macedonia</td> <td></td> </tr> </table>		Albania	Poland	Bulgaria	Romania	Latvia	Lithuania	Germany	Estonia	Luxembourg	Croatia	Slovenia	Bosnia	Macedonia	
Albania	Poland														
Bulgaria	Romania														
Latvia	Lithuania														
Germany	Estonia														
Luxembourg	Croatia														
Slovenia	Bosnia														
Macedonia															

Hong Kong Regional Office - Hong Kong	
Cummins Engine H.K. Ltd. Unison Industrial Centre 15th Floor, Units C & D 27-31 Au Pui Wan Street P. O. Box 840 Shatin Fo Tan, Shatin, N.T. Hong Kong Telephone: (852) 2606-5678 Fax: (852) 2691-1641, 2687-3552	
Country Covered: Hong Kong, Macau	

Pune Kirloskar Regional Office - India	
Kirloskar Cummins Limited Kothrud Pune - 411 029, India Telephone: (91-212) 33-0240, 33-5435, 33-1105	
Countries Covered:	Bhutan India Nepal
Milan Regional Office - Italy	
Cummins Diesel Italia S.P.A. Piazza Locatelli 8 Zona Industriale 20098 San Giuliano Milanese Milan, Italy Telephone: (+ 39-02) 98-83-111	
Country Covered:	Italy
North Asia Regional Office - Japan	
Cummins Diesel Sales Corporation 1-12-10 Shintomi Chuo-ku, Tokyo 104 Japan Telephone: (81-3) 3555-3131/2/3/4/5	
Country Covered:	Japan
Seoul Regional Office - Korea	
Cummins Korea Ltd. 5th Floor, Hye Sung Building 35-26 Sam Sung Dong, Kang Nam Ku Seoul, South Korea Telephone: (82-2) 516-0431/2/3, 517-3370/1	
Country Covered:	South Korea

Cummsa Regional Office - Mexico	
Cummins, S.A. de C.V. Arquimedes No. 209 Col. Polanco 11560 Mexico, D.F. Mexico Telephone: (52-5) 254-3822/3783/3622	Mailing/Shipping Address: Gonzalez de Castilla Inc. P.O. Box 1391 4605 Modern Lane Modern Industrial Park Laredo, TX 78040 Telephone: (512) 722-5207
Country Covered: Mexico	

Moscow Regional Office - Russia															
Cummins Engine Co., Inc. Park Place Office E708 Leninsky Prospect 113 Russia 117198 Telephone: (7-502) 256-5122 or 256-5123															
Countries Covered: <table style="width: 100%; border: none;"> <tr> <td style="width: 50%;">Armenia</td> <td style="width: 50%;">Moldova</td> </tr> <tr> <td>Azerbaijan</td> <td>Russia</td> </tr> <tr> <td>Belarus</td> <td></td> </tr> <tr> <td>Tajikistan</td> <td></td> </tr> <tr> <td>Georgia</td> <td>Turkmenistan</td> </tr> <tr> <td>Kyrgyzstan</td> <td>Ukraine</td> </tr> <tr> <td>Kazakhstan</td> <td>Uzbekistan</td> </tr> </table>		Armenia	Moldova	Azerbaijan	Russia	Belarus		Tajikistan		Georgia	Turkmenistan	Kyrgyzstan	Ukraine	Kazakhstan	Uzbekistan
Armenia	Moldova														
Azerbaijan	Russia														
Belarus															
Tajikistan															
Georgia	Turkmenistan														
Kyrgyzstan	Ukraine														
Kazakhstan	Uzbekistan														

South And East Asia Area Office - Singapore															
Cummins Diesel Sales Corporation 8 Tanjong Penjuru Jurong Industrial Estate Singapore 2260 Telephone: (65) 265-0155															
Countries Covered: <table style="width: 100%; border: none;"> <tr> <td style="width: 50%;">Bangladesh</td> <td style="width: 50%;">Malaysia</td> </tr> <tr> <td>Brunei</td> <td>Mongolia</td> </tr> <tr> <td>Burma/Mynamar</td> <td>Philippines</td> </tr> <tr> <td>Cambodia</td> <td>Singapore</td> </tr> <tr> <td></td> <td>Sri Lanka</td> </tr> <tr> <td>Indonesia</td> <td>Thailand</td> </tr> <tr> <td>Laos</td> <td>Vietnam</td> </tr> </table>		Bangladesh	Malaysia	Brunei	Mongolia	Burma/Mynamar	Philippines	Cambodia	Singapore		Sri Lanka	Indonesia	Thailand	Laos	Vietnam
Bangladesh	Malaysia														
Brunei	Mongolia														
Burma/Mynamar	Philippines														
Cambodia	Singapore														
	Sri Lanka														
Indonesia	Thailand														
Laos	Vietnam														

Taipei Regional Office - Taiwan	
<p>Cummins Corporation - Taiwan 12th Floor, No. 149 Min-Sheng E. Road Section 2 Taipei, Taiwan R.O.C. 104 Telephone: (886-2) 2503-8441</p>	
<p>Country Covered: Taiwan</p>	

Middle East Regional Office																									
<p>Cummins Diesel FZE Units ZF 5 & 6, Jebel Ali Free Zone Dubai United Arab Emirates Telephone: (971) 4 883-8998 Fax: (971) 4 883-8997 E-mail: cdfze@emirates.net.ae)</p>																									
<p>Countries Covered:</p> <table style="width: 100%; border: none;"> <tr> <td colspan="3">MIDEAST</td> </tr> <tr> <td style="width: 33%;">Afghanistan</td> <td style="width: 33%;">Jordan</td> <td style="width: 33%;">Saudi Arabia</td> </tr> <tr> <td>Bahrain</td> <td>Kuwait</td> <td>Sudan</td> </tr> <tr> <td>Cyprus</td> <td>Lebanon</td> <td>Syria</td> </tr> <tr> <td>Djibouti</td> <td>Oman</td> <td>U.A.E.</td> </tr> <tr> <td>Egypt</td> <td>Pakistan</td> <td>United Kingdom</td> </tr> <tr> <td>Iraq</td> <td>Qatar</td> <td>Yemen</td> </tr> <tr> <td>Iran</td> <td>Turkey</td> <td></td> </tr> </table>		MIDEAST			Afghanistan	Jordan	Saudi Arabia	Bahrain	Kuwait	Sudan	Cyprus	Lebanon	Syria	Djibouti	Oman	U.A.E.	Egypt	Pakistan	United Kingdom	Iraq	Qatar	Yemen	Iran	Turkey	
MIDEAST																									
Afghanistan	Jordan	Saudi Arabia																							
Bahrain	Kuwait	Sudan																							
Cyprus	Lebanon	Syria																							
Djibouti	Oman	U.A.E.																							
Egypt	Pakistan	United Kingdom																							
Iraq	Qatar	Yemen																							
Iran	Turkey																								

North/West/East and Central Africa Regional Office - Daventry (U.K.)

Cummins Engine Company Ltd.
Royal Oak Way South
Daventry, Northants NN11 5NU
England
Telephone: (44-1327) 886000

Countries Covered:

NORTH/WEST/EAST AND CENTRAL AFRICA

Benin (from Togo)	Gabon	Mauritania
Burkina-Paso	Gambia	Morocco
Burundi		
Cameroon	Ghana	Niger
Cape Verde	Guinea	Nigeria
Central African Republic	Guinea-Bissau	Sao Tome & Principe
	Ivory Coast	
Chad	Liberia	Senegal
Congo (D.R.)		Seychellès
Congo (P.R.)		
	Libya	Siera Leone
Djibouti		Somalia
Equatorial Guinea	Mali	Togo
	Malta	Tunisia
		Uganda

Latin America Regional Office - Miramar (U.S.A.)

Cummins Americas, Inc.
Miramar Park of Commerce
3450 Executive Way
Miramar, FL 33025
Telephone: (305) 431-5511

Countries Covered:

Argentina	Guatemala
Bolivia	Honduras
Chile	Nicaragua
Colombia	Panama
Costa Rica	Paraguay
Dominican Republic	Peru
El Salvador	Uruguay
Ecuador	Venezuela

Caracas Regional Office - Venezuela

Cummins Engine Company
Oficina de Delegado
Torre La Primera, Oficina 5-D
Av. Francisco de Miranda
Chacao, Caracas 1060

Mailing Address:
Cummins Engine Company M-227
c/o Jet Cargo International
P.O. Box 020010
Miami, FL 33102-0010 U.S.A.
Telephone: (58-2) 32-0563, 32-718

Counties

Covered:

Costa Rica
Dominican
Republic
El Salvador
Guatemala

Honduras
Nicaragua
Panama
Venezuela

Southern Africa Regional Office

Cummins Diesel South Africa (Pty) Ltd
13 Eastern Service Road
Kelvin View 2054
South Africa
Telephone: (00 27 11) 321 8700 (from U.K.)
Fax: (00 27 11 444 1899)

Mailing Address:
Wendywood 2144
Gauteng
South Africa

Countries

Covered:

Angola
Botswana
Comoros Island
Lesotho
Madagascar
Malawi
Mauritius
Mozambique
Nambia

Swaziland
South Africa
ST. Helena
Tanzania

Zambia
Zimbabwe

Distributors - International - Locations

ABU DHABI		- See United Arab Emirates
AFGHANISTAN		- See Middle East Regional Office
ALBANIA		- See Germany Regional Office - Gross-Gerau
ALGERIA		- See Cummins Diesel S.A. - Lyon
AMERICAN SAMOA		- See South Pacific Regional Office
ANDORRA		- See European Regional Office - Mechelen
ANGOLA	Luanda	Hull Blyth (Angola) Ltd Casa Inglesa Rua Major Kahangulo, 134/140 Luanda Republic of Angola Telephone: (244-2) 331817/337184/310026 Fax: (244-2) 335602
ANTIGUA		Miami (Office In U.S.A.) Cummins Southeastern Power, Inc. 9900 N.W. 77 Court Hialeah Gardens, FL 33016 Telephone: (305) 821-4200
ARGENTINA	Buenos Aires	Distribuidora Cummins, S.A. (DICUMAR) Av. Del Libertador 602 Piso 5 Buenos Aires, Argentina Telephone: (54-1)814-1895/1395/1393
ARUBA, ISLAND OF		- See Netherlands Antilles
AUSTRIA	Neudoerfl	Cummins Diesel Motorenvertriebsges m.b.H. Trenner & Co. Bickfordstr. 25 A-7201 Neudoerfl Austria Telephone: (43-2622) 77418/77625
BAHAMAS	Miami (Office in U.S.A.)	Cummins Southeastern Power, Inc. 9900 N.W. 77 Court Hialeah Gardens, FL 33016 Telephone: (305) 821-4200
BAHRAIN	Bahrain	Yusuf Bin Ahmed Kanoo W.L.L. P.O. Box 45, Manama Bahrain Telephone: (973) 738200
BALEARIC ISLANDS	Madrid (Office in Spain)	Cummins Ventas y Servicio, S.A. Torrelaguna, 56 28027 Madrid, Spain Telephone: (34-91) 367-2000 376-2404

BANGLADESH	Dhaka	Equipment & Engineering Co., Ltd. G.P.O. Box 2339 Dhaka 1000, Bangladesh Location: 56, Dilkusha Commercial Area 2nd Floor/Eastern Block Telephone: (880-2) 234357, 234060
BARBADOS	Miami (Office in U.S.A.)	Cummins Southeastern Power, Inc. 9900 N.W. 77 Court Hialeah Gardens, FL 33016 Telephone: (305) 821-4200
BELGIUM	Brussels	Cummins Distributor Belgium S.A. 623/629 Chaussee de Haecht B-1030 Brussels, Belgium Telephone: (24 hr.) (32-2) 216-81-10
BELIZE	Tampa (Office in U.S.A.)	Cummins Southeastern Power, Inc. 5421 N. 59th Street Tampa, FL 33610 Telephone: (813) 621-7202
BENIN		- See Togo
BERMUDA	Bronx (Office in U.S.A.)	Cummins Metropower, Inc. 890 Zerega Avenue Bronx, NY 10473 Telephone: (718) 892-2400
BHUTAN	Pune (Office in India)	Cummins Diesel Sales & Service (India) Ltd. 35A/1/2, Erandawana Pune - 411 038, India (State of Maharashtra) India Telephone: (91-212) 331234/331554/ 331635/330066/ 330166/330356/ 31703
BOLIVIA	La Paz	Machinery & Auto Service Casilla 4042 La Paz, Bolivia Location: Av. 20 de Octubre Esq. Rosendo Gutierrez Telephone: (591-2) 379650, 366394
BONAIRE, ISLAND OF		- See Netherlands Antilles
BOTSWANA		- See Southern Africa Regional Office - Kelvin
BRAZIL	Ananindeua	Marcos Marcelino & Companhia Ltda. Rodovia BR-316, Km 9 67020-010 Ananindeua, Para, Brazil Telephone: (55-91) 235-4100/4132/ 4143/4012

BRAZIL	Belo Horizonte	Distribuidora Cummins Minas S.A. 31950-640 Olhos D'Agua Norte Belo Horizonte, MG Brazil Telephone: (55-31) 288-1344
BRAZIL	Campo Grande	Distribuidora Cummins Mato Grosso Ltda. Rodovia BR 163 Km 01 79060-000 Campo Grande Mato Grosso do Sul, Brazil Telephone: (55-67) 787-1166
BRAZIL	Curitiba	Distribuidora Cummins Parana S.A. Rua Brasilio Itibere, 2195 80230 Curitiba, Parana Brazil Telephone: (55-41) 222-4036
BRAZIL	Fortaleza	Distribuidora Cummins Diesel Do Nordeste Ltda. Av. da Abolicao, 3882, Mucuripe 60165-081 Fortaleza, Ceara Brazil Telephone: (55-85) 263-1212
BRAZIL	Goianian	Distribuidora de Motores Cummins Centro Oeste Ltda. Av. Caiapo 777 - Setor Sta. Genoveva 74672-400 Goiania, Goias Brazil Telephone: (55-62) 207-1010
BRAZIL	Manaus	Distribuidora Cummins Amazonas Ltda. Estrada da Ponta Negra, 6080 - Sao Jorge 69037 Manaus, Amazonas, Brazil Telephone: (55-92) 656-5444
BRAZIL	Porto Alegre	Distribuidora Cummins Meridional S.A. Rua Dona Alzira, 98, Sarandi 91110-010 Porto Alegre, Rio Grande do Sul, Brazil Telephone: (55-51) 340-8222
BRAZIL	Rio de Janeiro	Distribuidora Cummins Leste Ltda. Rua Sariema, 138-Olaria 21030-550 Rio de Janeiro, Rio de Janeiro, Brazil Telephone: (55-21) 290-7899
BRAZIL	Sao Paulo	Companhia Distribuidora de Motores Cummins Rua Martin Burchard, 291 - Bras 03043-020 Sao Paulo, Sao Paulo, Brazil Telephone: (55-11) 270-2311

BRITISH VIRGIN ISLANDS		- See Puerto Rico
BRUNEI		- See Malaysia
BURKINA - FASO		- See North/West/East and Central Africa Regional Office - Daventry
BULGARIA		-See Germany Regional Office - Gross-Gerau
BURMA	Kuala Lumpur (Office In Malaysia)	Contact: Scott & English (M) Sdn Bhd P.O. Box 10324 50710 Kuala Lumpur West Malaysia Location: 16 Jalan Chan Sow Lin 55200 Kuala Lumpur West Malaysia Telephone: (60-3) 2211033
BURUNDI	Brussels (Office in Belgium)	Bia, S.A. Rameistraat, 123 B-3090 - Overijse, Belgium Telephone: (32-2) 6892811
CAMBODIA		- See South & East Asia Regional Office - Singapore
CANARY ISLANDS	Madrid (Office in Spain)	Cummins Ventas y Servicio, S.A. Torrelaguna, 56 28027 Madrid, Spain Telephone: (34-91) 3672000/3672404
CAPE VERDE		- See ECV Portugal
CENTRAL AFRICAN REPUBLIC		- See North/West Africa Regional Office - Daventry
CEYLON		- See Sri Lanka
CHAD		- See North/West/East and Central Africa Regional Office - Daventry
CHILE	Santiago	Distribuidora Cummins Diesel S.A.C.I. Casilla Postal 1230 Calle Bulnes 1203 Santiago, Chile Corporate Office: Av. Providencia 2653, Office 1901 Santiago, Chile Telephone: (56-2) 698-2113/4/5, 697-3566/7/8, 697-2709
CHINA, PEOPLE'S REPUBLIC	Beijing	Cummins Engine (Beijing) Co., Ltd. No. 8, Wan Yuan Street Beijing Economic and Technology Development Zone Beijing, 100176 People's Republic of China Telephone: (86-10) 67882258 Fax: (86-10) 67882285

CHINA, PEOPLE'S REPUBLIC	Shenyang	Cummins Engine (China) Investment Co., Ltd. - Shenyang No. 198, Lianhe Rd., Dadong District Shenyang, 110044 People's Republic of China Telephone: (86-24) 88094014, 88905794 Fax: (86-24) 88905970
CHINA, PEOPLE'S REPUBLIC	Kunming	Cummins Engine (China) Investment Co., Ltd. - Kunming Suite A4, A5 No. 114 East 2nd Ring Rd. Kunming, 650224 People's Republic of China Telephone: (86-871) 5629579, 5630958 Fax: (86-871) 5632210
CHINA, PEOPLE'S REPUBLIC	Urumqi	Cummins Engine (China) Investment Co., Ltd. - Urumqi No. 275, A Le Tai Rd., Urumqi, 830011 Xinjiang, People's Republic of China Telephone: (86-991) 3844712, 3844723 Fax: (86-991) 3849232
CHINA, PEOPLE'S REPUBLIC	Shanghai	Cummins Engine (China) Investment Co., Ltd. - Shanghai 1st Floor, 555 Zhong Shan Nan Er Rd., Shanghai, 200032 People's Republic of China Telephone: (86-21) 64033999 Fax: (86-21) 64033111
CHINA, PEOPLE'S REPUBLIC	Wuhan	Cummins Engine (China) Investment Co., Ltd. - Wuhan No. 198, Jianshe Rd., Jiangnan District Wuhan, 430030 People's Republic of China Telephone: (86-27) 83330180, 83330182 Fax: (86-27) 83330180 ext. 812
CHINA, PEOPLE'S REPUBLIC	Guangzhou - South China Regional Office	Cummins Engine (China) Investment Co., Ltd. - Guangzhou Rm. 211, Bai Yun Hotel, 367 Huan Shi Dong Rd. Guangzhou, 510065 People's Republic of China Telephone: (86-20) 83313136, 83313137 Fax: (86-20) 83313135
CHINA, PEOPLE'S REPUBLIC	Shenzhen (JV)	Shenzhen Chongfa Cummins Engine Co., Ltd. Unit D2-F2.6 Tian An Che Gong Miao Industrial Estate Shen Nan Rd., Shenzhen, 518040 People's Republic of China Telephone: (86-755) 3415479 Fax: (86-755) 3415480
COLOMBIA	Barranquilla	Cummins de Colombia S.A. Apartado Aereo 5347 Barranquilla, Colombia Location: Calle 30, No. 19 - 21 Telephone: (57-58) 40-02-06/40-13-46

COLOMBIA	Bogota	Cummins Colombiana Ltda. Apartado Aereo No. 7431 Bogota, D.E. Colombia Location: Av. Americas X Carrera 42C No. 19-45 Telephone: (57-1) 244-5688/5882
COLOMBIA	Bucaramanga	Cummins API, Ltda. Apartado Aereo 352 Bucaramanga, Colombia Location: Autopista a Giron, Km 7 Telephone: (57-76) 468060
COLOMBIA	Cali	Distribuidora Cummins del Valle, Ltda. Apartado Aereo No. 6398 Cali, Colombia Location: Av. 3a. # 39-35 - Vipasa Telephone: (57-3) 65-4343
COLOMBIA	Medellin	Equipos Tecnicos Ltda. Apartado Aereo No. 2046 Medellin, Colombia Location: Carrera 52 No. 10-184 Telephone: (57-4) 255-4200
COLOMBIA	Pereira	Equipos Tecnicos Ltda. C.Q.R. Apartado Aereo No. 1240 Pereira, Colombia Location: Carrera 8a. No. 45-39 Telephone: (57-63) 366341
COMOROS		- See Southern Africa Regional Office - Kelvin
CONGO, PEOPLE'S REPUBLIC	Brussels (Office in Belgium)	Bia, S.A. Rameistraat, 123 B-3090 Overijse, Belgium Telephone: (32-2) 6892811
CORSICA		- See France
COSTA RICA	San Jose	Servicios Unidos, S.A. P.O. Box 559 San Jose, Costa Rica Location: 100 metros al este de Excelsior Antiguo Curridabat, San Jose Telephone Office: (506) 53-93-93 Telephone Service Shop: (506) 26-00-76
CUBA	Miami (Office in U.S.A.)	Cummins Southeastern Power, Inc. 9900 N.W. 77 Court Hialeah Gardens, FL 33016 Telephone: (305) 821-4200

CYPRUS	Nicosia	Alexander Dimitriou & Sons Ltd. P.O. Box 21932 Nicosia, Cyprus CY-1515 Location: 4 Salamis Avenue Telephone: (357-2) 349450
CZECH REPUBLIC		- See Austrian Distributor
DENMARK	Glostrup	Cummins Diesel Salg & Service A/S Hovedvejen 233B Osted DK-4000 Roskilde Denmark Telephone: (45-46) 423 552
DJIBOUTI		- See North/West/East and Central Africa
DOMINICA	Miami (Office in U.S.A.)	Cummins Southeastern Power, Inc. 9900 N.W. 77 Court Hialeah Gardens, FL 33016 Telephone: (305) 821-4200
DOMINICAN REPUBLIC	Santo Domingo	Argico C. Por A. P.O. Box 292-2 Feria Santo Domingo Dominican Republic, ZP-6 Location: Calle Jose A. Soler No. 3, ESQ. Avenida Lope de Vega Telephone: (809) 562-6281
DUBAI		- See United Arab Emirates
ECUADOR	Guayaquil	Motores Cummins (MOTCUM) S.A. P.O. Box 1062 Guayaquil, Ecuador Location: Avenida Carlos Julio Arosemena Km. 4 Telephone: (593-4) 203995/201177
ECUADOR	Quito	Rectificadora Botar S.A. P.O. Box 17-01-3344 Quito, Ecuador Location: Av. 10 de Agosto No. 5980 Telephone: (593-2) 465-176/177/ 178/195/197
EGYPT	Cairo	ADAT P.O. Box 1572 Cairo, Egypt Sales and Service Location: 25, Pyramid Road Giza, Cairo, Egypt Telephone: (20-2) 385-4001/2/4/5/6/8/9

EL SALVADOR	San Salvador	Salvador Machinery Company, S.A. de C.V. P.O. Box 125 San Salvador, El Salvador Location: Blvd. Ejercito Nacional Telephone: (503) 711022, 228388
ENGLAND		- See United Kingdom
EQUATORIAL GUINEA		- See North/West/East and Central Africa Regional Office - Daventry
ESTONIA		- See Gross Gerau Regional Office - Germany
FAROE ISLANDS	Wellingborough (Office in United Kingdom)	Cummins Diesel Rutherford Drive Park Farm South Wellingborough Northants NN8 2QH, England Telephone: (44-1933) 334200
FERNANDO PO		- See Spain
FIJI		- See Cummins Diesel Sales & Service New Zealand Ltd.
FINLAND	Helsinki	Machinery OY P.O. Box 560 FIN 01741 Varta Finland Telephone: Int: (358-9) 8955 2215
FRANCE	Lyon	Cummins Diesel S.A. Sales Corporation 39, rue Ampere Z.I. 69680 Chassieu, France Telephone: (33) 72-22-92-72 Parts and Service Telephone: (33) 72-22-92-69
GABON		- See North/West/East and Central Africa Regional Office - Daventry
GAMBIA		- See Matforce Senegal
GEORGIA		- See Moscow Regional Office - Moscow
GERMANY	Gross-Gerau	Cummins Diesel Deutschland GmbH P.O. Box 1134 D-6080 Gross-Gerau, Germany Location: Odenwaldstr. 23 Telephone: (49-6152) 174-0
GHANA	Accra	J&D Diesels and Systems P.O: Box c2381 Cantonments Accra, Ghana Telephone: (233-21) 30-14-51

GREECE	Athens	Ergotrak Box 51528 14 Km. National Rd. Athens-Lamia 14510 Kifissia, Greece Telephone: (30-1) 6293400/41
GREENLAND		- See Denmark
GRENADA	Miami (Office in U.S.A.)	Cummins Southeastern Power, Inc. 9900 N.W. 77 Court Hialeah Gardens, FL 33016 Telephone: (305) 821-4200
GUADELOUPE	Miami (Office in U.S.A.)	Cummins Southeastern Power, Inc. 9900 N.W. 77 Court Hialeah Gardens, FL 33016 Telephone: (305) 821-4200
GUAM	Barrigada	Mid-Pac Far East, Inc. Airport Industrial Park 825 Tiyan Parkway Barrigada, Guam 96921 Telephone: (671) 632-5160
GUATEMALA	Guatemala City	Maquinaria y Equipos, S.A. P.O. Box 2304 Guatemala City, Guatemala Location: Carretera Amatitlan Km 12 zona 12 Telephone: (502-2) 773334/7/9
GUINEA	Brussels (Office in Belgium)	BIA s.a. Rameistraat, 123 B-3090 - Overijse, Belgium Telephone: (32-2) 6892811
GUINEA BISSAU		- See North/West/East and Central Africa Regional Office - Daventry
GUYANA	Miami (Office in U.S.A.)	Cummins Southeastern Power, Inc. 9900 N.W. 77 Court Hialeah Gardens, FL 33016 Telephone: (305) 821-4200
GUYANA, FRENCH	Miami (Office in U.S.A.)	Cummins Southeastern Power, Inc. 9900 N.W. 77 Court Hialeah Gardens, FL 33016 Telephone: (305) 821-4200
HAITI	Miami (Office in U.S.A.)	Cummins Southeastern Power, Inc. 9900 N.W. 77 Court Hialeah Gardens, FL 33016 Telephone: (305) 821-4200
HOLLAND		- See Netherlands

HONDURAS	Tegucigalpa	Comercial Laeisz Honduras, S.A. P.O. Box 1022 Tegucigalpa, D.C., Honduras Location: Zona La Burrera, Blvd. Toncontin Frente a Gasolinera Esso. Telephone: (504) 333570/335615
HONG KONG	Kowloon	Cummins Engine H. K. Ltd. P.O. Box 840 Shatin N.T., Hong Kong Location: Unison Industrial Centre 15th Floor, Units C & D 27-31 Au Pui Wan Street Fo Tan, Shatin, Hong Kong Telephone: (852) 2606-5678 Fax: (852) 2691-1641, 2687-3552
ICELAND	Velasalan H.F.	Ananaustrum 1 121 Reykjavik Iceland Telephone: (354) 5526122
INDIA	Pune	Cummins Diesel Sales & Service (India) Ltd. 35A/1/2, Erandawana Pune - 411 038, (State of Maharashtra) India Telephone: (91-212) 331234, 331554, 331635, 330066, 330166, 330356, 331703
INDIA	Bombay	Cummins Diesel Sales & Service (I) Ltd. 298, Perin Nariman Street, Fort, Bombay 400001, India Telephone: (91-22) 2863566/2862247
INDIA	Calcutta	Cummins Diesel Sales & Service (I) Ltd. 94, Tivoli Court, I/C Ballygunge Circular Road Calcutta 700 019 (West Bengal), India Telephone: (91-33) 2478065/2470481/ 2470774
INDIA	New Delhi	Cummins Diesel Sales & Service (I) Ltd. Flat No. 307, Meghdoot Building 94 Nehru Place New Delhi 110 019, India Telephone: (91-11) 6431051/6445756/ 6452817
INDIA	Raipur	Cummins Diesel Sales & Service (I) Ltd. Plot No. 15, Jalashay Marg Choube Colony Raipur 492 001 (Madhya Pradesh), India Telephone: (91-771) 24994/23157/29498

INDIA	Ranchi	Cummins Diesel Sales & Service (I) Ltd. 'Shanti Kunj' C-202, Vidyalaya Marg Road No. 1, Ashoknagar Ranchi 834 002 (Bihar) India Telephone: (91-651) 301948/303623
INDONESIA	Jakarta	P.T. Alltrak 1978 P.O. Box 64/KBYL Jakarta Selatan 12330, Indonesia Location: J1. R.S.C. Veteran No. 4 Bintaro, Rempoa Telephone: (62-21) 736-1978/736-3302
IRAN		- See Middle East Regional Office - United Arab Emirates
IRAQ		- See Middle East Regional Office or United Arab Emirates
IRELAND	Wellingborough (Office in England)	Cummins Diesel Denington Estate Wellingborough Northants NN8 2QH, England Telephone: (44-1933) 334200
ISRAEL	Tel Aviv	Israel Engines & Trailers Co. Ltd. Levinson Brothers Engineers P. O. Box 390 33 Hahashmal Street Tel Aviv, Israel 61003 Telephone: (972-3) 7106222
ITALY	Milan	Cummins Diesel Italia S.p.A. Piazza Locatelli, 8 Zona Industriale Sesto Uteriano 20098 S. Giuliano Milanese (Milan), Italy Telephone: (39-2) 9828-1235/6/7
IVORY COAST		- See Cote d'Ivoire
JAMAICA	Miami (Office in U.S.A.)	Cummins Southeastern Power, Inc. 9900 N.W. 77 Court Hialeah Gardens, FL 33016 Telephone: (305) 821-4200
JAPAN	Tokyo	Cummins Diesel (Japan) Ltd. 1-12-10-Shintomi Chuo-ku, Tokyo 104 Japan Telephone: (81-3) 3555-8511
JORDAN	Amman	S.E.T.I. Jordan Limited P.O. Box 8053 Amman, Jordan Telephone: (962-6) 621867/621884

KENYA	Nairobi	Werrot & Company Limited P.O. Box 41216 Nairobi, Kenya Location: Lusaka Road Telephone: (254-150) 20316
KOREA, SOUTH	Seoul	Hwa Chang Trading Co., Ltd. Central P.O. Box No. 216 Seoul, South Korea Location: 143-11 Doksan-dong, Kuro-ku Telephone: (82-2) 854-0071/2/3/4/5, 869-1411/2/3
KUWAIT	Kuwait	General Transportation & Equipment Co. (Sales Department) P.O. Box 1096 13011 Safat, Kuwait Location: Shuwaikh Behind Canada Dry Factory Telephone: (965) 4833380/1/2
KUWAIT	Kuwait	General Transportation & Equipment Co. (Service Department) East Ahmadi Area 13011 Safat, Kuwait Telephone: (965) 3981577
LAOS		- See South and East Asia Regional Office - Singapore
LATVIA		- See Moscow Regional Office - Moscow
LEBANON	Beirut	S.E.T.I. Charles Keller S.A.L. B.P. 16-6726 Beirut, Lebanon Location: Corniche du Fleuve Telephone: (961-1) 425040/41
LESOTHO		- See South Africa
LIBYA		- See North/West Africa Regional Office - Daventry
LIECHTENSTEIN		- See Switzerland
LUXEMBOURG	Gross-Gerau (Office in Germany)	Cummins Diesel Deutschland GmbH P.O. Box 11 34 Odenwaldstrasse 23 D-6080 Gross-Gerau, Germany Telephone: (49-6152) 174-0
MACAU		- See Hong Kong
MADAGASCAR		- See East and Southern Africa Regional Office - Harare
MADEIRA ISLANDS		- See Portugal

MALAYSIA	Kuala Lumpur	Cummins Diesel Sales & Service Div. of Scott & English (M) Sdn. Bhd. P.O. Box 10324 50710 Kuala Lumpur, West Malaysia Location: 16 Jalan Chan Sow Lin 55200 Kuala Lumpur Telephone: (60-3) 2211033
MALI		- See Senegal (Matforce)
MALTA	Valletta	Plant & Equipment Ltd. Regency House 254, Republic Street Valletta, Malta Telephone: (356) 23-26-20, 23-33-43, 23-16-23, 24-75-17
MARTINIQUE	Miami (Office in U.S.A.)	Cummins Southeastern Power, Inc. 9900 N.W. 77 Court Hialeah Gardens, FL 33016 Telephone: (305) 821-4200
MEXICO	Guadalajara	Cummins Del Occidente, S.A. Lazaro Cardenas No. 2950 Fracc. Alamo Industrial 45560 Guadalajara, Jal. Mexico Telephone: (52-3) 670-93-06, 670-53-38, 670-63-61, 670-62-33
MEXICO	Monterrey	Tecnica Automotriz, S.A. Av. Alfonso Royes No. 3637 Nte. Monterrey, Nuevo Leon, Mexico Telephone: (52-83) 51-41-51, 51-46-56
MEXICO	Merida	Cummins Del Sureste, S.A. de C.V. Av. Aviacion Civil No. 647 Esquina Calle 100 Col. Sambula 97259 Merida, Yucatan, Mexico Telephone: (52-99) 24-11-55, 24-00-15
MEXICO	Puebla	Cummins de Oriente, S.A. de C.V. Av. Reforma No. 2112, Puebla, Pue. Mexico Telephone: (52-22) 48-76-74, 48-76-75
MEXICO	Queretaro	Distribuidor Cummins Del Centro, S.A. de C.V. Bld. Bernardo Quintana No. 518 Col. Arboledas C.P. 76140 Queretaro, Qro., Mexico Telephone: (52-42) 12-41-90, 12-58-90, 12-62-94, 14-04-16, 14-08-81, 14-15-91
MEXICO	Tlalnepantla	Distribuidor Cummins Metropolitana, S.A. DE C.V. Sor Juana Ines de la Cruz No. 555 54000 Tlalnepantla, Edo. de Mexico, Mexico Telephone: (52-5) 327-38-00, 390-64-37, 390-12-27

MOROCCO	Casablanca	Soberma (Groupe Auto Hall) Société Soberma Chamin Ain Borja Quartier Beausite Ain Sebaâ Casablanca, Morocco Telephone: (212-22) 66 66 40-43 Fax: (212-22) 66 66 45-46
MOZAMBIQUE		- See Southern Africa Regional Office - Kelvin
NAMIBIA (Southwest Africa)	Walvis Bay	Namib Diesel P.O. Box 2449, Walvis Bay, Namibia Location: 210, 2nd Street Walvis Bay, Namibia Telephone: 064-203971
NEPAL	Pune (Office in India)	Cummins Diesel Sales & Service (India) Ltd. 35A/1/2, Erandawana Pune, - 411 038, (State of Maharashtra) India Telephone: (91-212) 331234, 331554, 331635, 330066, 330166, 330356, 331703
NETHERLANDS	Dordrecht	Cummins Diesel Sales & Service, B.C. Galvanistraat 35 3316 GH Dordrecht Netherlands Telephone: (31-78) 618-12-00
NETHERLANDS ANTILLES	Miami (Office in U.S.A.)	Cummins Southeastern Power, Inc. 9900 N.W. 77 Court Hialeah Gardens, FL 33016 Telephone: (305) 821-4200
NEW CALEDONIA		- See South Pacific Regional Office - Melbourne
NEW GUINEA		- See Papua New Guinea
NICARAGUA	Managua	F. Alf. Pellas & Cia. Apartado Postal No. 46 Managua, Nicaragua Location: 6a. Calle 30 y 31 Avs. N.O., Zona 5 Telephone: (505-2) 660616
NIGERIA	Lagos	SCOA TRAC P.M.B. 21108 Ikeja, Lagos Nigeria Location: Apapa-Oshodi Expressway Isolo Industrial Estate, Isolo Telephone: (234-1) 45-21-539/45-21-803

NIGERIA	Paris (Office in France)	SCOA INTER Immeuble Marie-Joseph Rue du Maréchal de Lattre de Tassigny 78990 Elancourt France Telephone: (33-1) 30-68-82-68
NORTHERN IRELAND		- See United Kingdom
NORWAY	Oslo	Cummins Diesel Salg & Service A/S Hestehagen 3 Postboks 151 N-1441 DR0BAK Norway Telephone: (47) 64 90 70 80
OMAN	Ruwi	Universal Engineering Services L.L.C. P.O. Box 2688 Ruwi Sultanate of Oman Telephone: (968) 590830, 591304
PAKISTAN	Karachi	Diesel Power Systems 2 Bangalore Town Main Shahrah-e-Faisal Karachi 75350 Pakistan Telephone: (92) 21-453 9603/4/5
PANAMA	Panama City	Grupo Tiesa, S.A. Apartado Postal #55-0549 Partillo, Panama Telephone: (507) 67-3866
PAPUA NEW GUINEA	Sydney (Office in Australia)	Cummins Diesel Sales & Service P.O. Box 150 Cabramatta, 2166 New South Wales, Australia
PARAGUAY	Asuncion	Automotores y Maquinaria, S.R.L. Yegros y Fulgencio R. Moreno P.O. Box 1160 Asuncion, Paraguay Telephone: (595-21) 493111, 493115
PERU	Lima	Comercial Diesel del Peru S.A. P.O. Box 14-0234 Lima, Peru Location: Ave. V.R. Haya de la Torre 2648 Lima 3, Peru Telephone: (51-14) 74-3173/4374/ 3144/2281

PHILIPPINES	EDSA	Power Systems, Inc. EDSA P.O. Box 3241 Manila Philippines 1501 Location: 79E. Delos Santos Ave. Mandaluyong, Metro Manila Telephone: (63-2) 791769, 791771, 5311945, 5315448, 5311934, 5312531, 53414513
POLAND		Polremaco 30-709 Krakow Ul. Stoczniewcow 3 Poland Telephone: (48-12) 6561917
PORTUGAL	Lisbon	Electro Central Vulcanizadora, Lda. P.O. Box 3077 1302 Lisbon, Portugal Location: Rua Conselheiro Martins de Carvalho Lote 1480 1400 Lisboa (Restelo) Telephone: (351-2) 303 4800
QATAR	Doha	Jaidah Motors & Trading Co. P.O. Box 150 Doha, Qatar (Arabian Gulf) Telephone: (974) 442-6161
REUNION		- See Lyon Regional Office - Lyon
RIO DE ORO		- See Spain
ROMANIA		- See Germany Regional Office - Gross-Gerau
RUSSIA		- See Moscow Regional Office - Moscow
RWANDA	Brussels (Office in Belgium)	Bia, S.A. Rameistraat, 123 B-3090 - Overijse, Belgium Telephone: (32-2) 6892811
ST. LUCIA	Miami (Office in U.S.A.)	Cummins Southeastern Power, Inc. 9900 N.W. 77 Court Hialeah Gardens, FL 33016 Telephone: (305) 821-4200
ST. VINCENT	Miami (Office in U.S.A.)	Cummins Southeastern Power, Inc. 9900 N.W. 77 Court Hialeah Gardens, FL 33016 Telephone: (305) 821-4200
SAN MARINO		- See Italy
SAO TOME AND PRINCIPE		- See North/West/East and Central Africa Regional Office - Daventry

SAUDI ARABIA	Al-Khobar	GCC Olayan P.O. Box 356 Al-Khobar 31952 Saudi Arabia Telephone: (966-3) 882-0888
SCOTLAND		- See United Kingdom
SENEGAL	Dakar	Matforce B.P. 397 Dakar, Senegal Location: 10 Avenue Faidherbe Telephone: (221-8) 399500 Fax: (221-8) 399531/399550 Equipements et Services (Mining Only) BP 15372-Fann Dakar Senegal Contacts: Mr. Jean Smets Tel: (221-8) 60 77 76 & 24.73 62 Fax: (221-8) 60 95 98
SEYCHELLES		- See North/West/East & Central Regional Office - Daventry
SIERRA LEONE		- See North/West/East and Central Africa Regional Office - Daventry
SINGAPORE	Singapore	Applied Diesel Sales & Service Pte Ltd 8 Tanjong Penjuru Jurong Industrial Estate Singapore 2260 Telephone: (65) 261-3555
SLOVAKIA		- See European Regional Office - Gross-Gerau
SOLOMON ISLANDS		- See South Pacific Regional Office - Melbourne
SOMALIA		- See East and Southern Africa Regional Office - Harare
SOUTH AFRICA	Johannesburg	Cummins Diesel South Africa Pty. Ltd. Private Bag X7 Wendywood 2144 South Africa Location: 13 Eastern Service Road Kelvin View 2054 Telephone: (27-11) 321 8700
SOUTHWEST AFRICA		- See Namibia
SPAIN	Madrid	Cummins Ventas y Servicio S.A. Torrelaguna, 56 28027 Madrid, Spain Telephone: (34-91) 367-2000/3672404
SPANISH GUINEA		- See Spain

SRI LANKA	Colombo	Trade Promoters Ltd P.O. Box 321 69, Walukarama Road Colombo 3 Sri Lanka Telephone: (94-1) 573927, 574651, 575005
SUDAN		- See Middle East Regional Office - United Arab Emirates
SURINAM	Miami (Office in U.S.A.)	Cummins Southeastern Power, Inc. 9900 N.W. 77 Court Hialeah Gardens, FL 33016 Telephone: (305) 821-4200
SWAZILAND		- See South Africa
SWEDEN	Stockholm	SMA Maskin AB Aggelundavagen 7 S-17562 Jarfalla Sweden Telephone: (46-8) 56-222-500
SWITZERLAND	Regensdorf	Robert Aebi S.A. Riedhofstrasse 100 8105 Regensdorf Switzerland Telephone: (41-1) 842-5111
SYRIA	Damascus	Puzant Yacoubian & Sons P.O. Box 3617 Damascus, Syria Location: Abou Baker El Saddik Street Kafar Sousse Square Telephone: (963-11) 212-8600
TAHITI, ISLAND OF		- See French Polynesia
TAIWAN	Taipei (JV)	Cummins Power Service & Parts Corp. No. 115, Wu Ko 1st Rd., Wu Ku, Industrial District Taipei, Taiwan, R.O.C. Telephone: (886-2) 2290-0331 Fax: (886-2) 2290-0393
TANZANIA		- See South African Regional Office - Kelvin
THAILAND	Bangkok	Diethelm & Company Ltd. 1696 New Petchburi Road Bangkok 10310, Thailand Telephone: (66-2) 254-4900
TOGO (and BENIN)	Lome	Togomat B.P. 1641 Lome, Togo Location: Zone Industrielle CNPPME Telephone: (228) 27-23-95
TONGA, ISLAND OF		- See South Pacific Regional Office - Melbourne

TRINIDAD and TOBAGO	Miami (Office in U.S.A.)	Cummins Southeastern Power Inc. 9900 N.W. 77 Court Hialeah Gardens, FL 33016 Telephone: (305) 821-4200
TURKEY	Istanbul	Hamamcioglu Muesseseleri Okul Cad. No. 9 81474 Orhanli - Tuzia Istanbul, Turkey Telephone: (90) 216-394-3210
UKRAINE		- See Moscow Regional Office - Moscow
UNITED ARAB EMIRATES	Dhabi	Cummins Diesel FZE P.O. Box 17636 Units ZF516, Jebel Ali Free Zone Dhabi, United Arab Emirates Telephone: (971) 4-883-8998
UNITED KINGDOM	Wellingborough	Cummins Diesel Rutherford Drive Park Farm South Wellingborough Northants NN8 2QH, England Telephone: (44-1933) 334200
URUGUAY	Montevideo	Santaro S.A. P.O. Box 379 Montevideo Uruguay Location: Avenida Millan No. 2441 Telephone: (598-2) 293908
VATICAN CITY		- See Italy
VENEZUELA	Caracas	Sudimat Apartado Postal 1322 Carmelitas Caracas 1010 Venezuela Location: Final Avenida San Martin Urb. la Quebradita Caracas 1061 Telephone: (58-2) 442-6161/2647
VIETNAM	Hanoi	Diethelm & Co. Ltd. Engineering Room No. 1, 2nd Floor 8 Trang Thi Street Hanoi, Vietnam Telephone: (84-4) 260-332, 244-394
VIETNAM	Ho Chi Minh City	Diethelm & Co. Ltd. Engineering 3rd Floor, IBC Building 1 Me Linh Square District 1 Ho Chi Minh City, Vietnam Telephone: (84-8) 294-102, 294-103
WESTERN SAMOA		- See South Pacific Regional Office - Melbourne

YEMEN	Sana'a	Zubieri Trading Co. P.O. Box 535 Sana'a, Yemen Arab Republic Telephone: (967) 1-223943/224051
YUGOSLAVIA		Cummins Dizel Motori Doo Prodaja I Servis Autoput 22 11080 Zemun Beograd F.R. Yugoslavia Telephone: (381-11) 314 9071
ZAMBIA	Ndola	Cummins Diesel Services (Zambia) Ltd. P.O. Box 71501 Ndola, Zambia Telephone: (260-2) 610729
ZIMBABWE	Harare	Cummins Zimbabwe (Pvt) Ltd. P.O. Box ST363 Southerton Harare, Zimbabwe Location: 72 Birmingham Road Southerton, Harare Telephones: (263-4) 621871/2/3/4/5

Section TS - Troubleshooting Symptoms

Section Contents

	Page
Troubleshooting Procedures and Techniques	TS-1
General Information.....	TS-1
Troubleshooting Symptoms Charts	TS-2
General Information.....	TS-2
Lubricating Oil Temperature Above Specification.....	TS-26
Coolant Loss - External.....	TS-3
Coolant Temperature Above Normal - Gradual Overheat.....	TS-4
Coolant Temperature Below Normal.....	TS-5
Engine Acceleration or Response Poor.....	TS-6
Engine Decelerates Slowly.....	TS-7
Engine Difficult to Start or Will Not Start.....	TS-8
Engine Noise Excessive.....	TS-9
Engine Power Output Low.....	TS-10
Engine Runs Rough at Idle.....	TS-11
Engine Runs Rough or Misfires.....	TS-12
Engine Speed Surges at Low or High Idle.....	TS-13
Engine Starts But Will Not Keep Running.....	TS-14
Engine Transient Response Poor.....	TS-15
Engine Vibration Excessive.....	TS-16
Engine Will Not Crank or Cranks Slowly (Air Starter).....	TS-17
Engine Will Not Reach Rated Speed (RPM).....	TS-18
Engine Will Not Shut Off.....	TS-20
Fuel Consumption Excessive.....	TS-21
Lubricating Oil Consumption Excessive.....	TS-22
Lubricating Oil Pressure High.....	TS-23
Lubricating Oil Pressure Low.....	TS-24
Lubricating Oil Sludge in the Crankcase Excessive.....	TS-25

This Page Left Intentionally Blank

Troubleshooting Procedures and Techniques

General Information

This guide describes some typical engine operating problems, their causes, and some acceptable corrections to those problems. Unless noted otherwise, the problems listed are those which an operator can diagnose and repair.

▲ WARNING ▲

Performing troubleshooting procedures NOT outlined in this section can result in equipment damage or personal injury or death. Troubleshooting must be performed by trained, experienced technicians. Consult a Cummins Authorized Repair Location for diagnosis and repair beyond that which is outlined, and for symptoms not listed in this section. Before beginning any troubleshooting, refer to General Safety Instructions in Section i of this manual.

Follow the suggestions below for troubleshooting:

- Study the complaint thoroughly before acting
- Refer to the engine system diagrams
- Do the easiest and most logical things first
- Find and correct the cause of the complaint

Troubleshooting Symptoms Charts

General Information

Use the charts on the following pages of this section to aid in diagnosing specific engine symptoms. Read each row of blocks from top to bottom. Follow through the chart to identify the corrective action.



WARNING

Troubleshooting presents the risk of equipment damage, personal injury or death. Troubleshooting must be performed by trained, experienced technicians.

Coolant Loss - External

Cause

Correction

STEP 1
Coolant level is above specification

Check the coolant level. Refer to Procedure 008-066 (Coolant Level) in Section 3.

OK
Go To Next Step

STEP 2
External coolant leak

Inspect the engine for coolant leaking from hoses, draincocks, water manifold, expansion and pipe plugs, fittings, radiator core, exhaust heat shield, heat exchanger, air compressor and cylinder head gaskets, lubricating oil cooler, water pump seal, and OEM-mounted components that have coolant flow.

OK
Go To Next Step

STEP 3
Radiator cap is **not** correct, is malfunctioning, or has low-pressure rating

Check the radiator pressure cap. Refer to the OEM service manual.

OK
Go To Next Step

STEP 4
Fill line or vent lines are restricted, obstructed, or **not** routed correctly

Check the vent lines and the fill line for correct routing and for restriction. Refer to OEM specifications.

OK
Go To Next Step

STEP 5
Coolant fill line is restricted or obstructed

Check the coolant fill line for restrictions or obstructions. Refer to the OEM installation instructions.

OK
Go To Next Step

STEP 6
Engine is overheating

Refer to Coolant Temperature Above Normal symptom tree.

Coolant Temperature Above Normal - Gradual Overheat

Cause

Correction

STEP 1

Coolant level is below specification

Inspect the engine and cooling system for external coolant leaks. Repair if necessary. Add coolant. Refer to Procedure 018-018 (Cooling System) in Section V.

OK

Go To Next Step

STEP 2

Lubricating oil level is above or below specification

Check the oil level. Add or drain oil, if necessary. Refer to Procedure 007-043 (Lubricating Oil Level) in Sections 3 and Procedure 007-002 (Lubricating Oil and Filters) in Section 4.

OK

Go To Next Step

STEP 3

Load is excessive for engine horsepower rating

Reduce the load on the engine. Refer to OEM specifications.

OK

Go To Next Step

STEP 4

Coolant temperature gauge is malfunctioning

Test the temperature gauge. Repair or replace the gauge if necessary. Refer to the OEM service manual.

OK

Go To Next Step

STEP 5

Radiator fins are damaged or obstructed with debris

Inspect the radiator fins. Clean and repair the fins as necessary. Refer to the OEM service manual.

OK

Go To Next Step

STEP 6

Radiator cap is **not** correct, is malfunctioning, or has low-pressure rating

Check the radiator pressure cap. Refer to the OEM service manual.

OK

Go To Next Step

STEP 7

Cooling system hose is collapsed, restricted, or leaking

Inspect the hoses. Refer to OEM installation instructions.

Coolant Temperature Below Normal

Cause

Correction

STEP 1

Engine is operating at low ambient temperature

Check the shutters and engine compartment air. Refer to Cold Weather Operation, Bulletin 3387266.

OK

Go To Next Step

STEP 2

Temperature gauge malfunction

Check or replace the temperature gauge. Refer to the OEM service manual.

OK

Go To Next Step

STEP 3

Thermostat is **not** operating properly.

Check the thermostat for correct operation. Refer to a Cummins Authorized Repair Facility.

Engine Acceleration or Response Poor

Cause

Correction

STEP 1

Verify the complaint

Refer to the Human Machine Interface, if available or an electronic service tool to verify system faults and system status. Contact a Cummins Authorized Repair Facility if an electronic service tool is required.

OK

Go To Next Step

STEP 2

Fuel leak

Check the fuel lines, fuel connections, and fuel filters for leaks using the combustible gas detector service tool. Refer to Procedure 006-063 (Fuel Filter) in Section 6. If the leak persists contact a Cummins Authorized Repair Facility.

OK

Go To Next Step

STEP 3

Load is excessive for engine horsepower rating

Reduce the load on the engine. Refer to the OEM service manual.

OK

Go To Next Step

STEP 4

Air intake or exhaust leaks

Check for loose or damaged piping connections and missing pipe plugs. Check the turbocharger and exhaust manifold mounting. Refer to the OEM service manual.

OK

Go To Next Step

STEP 5

Air intake system restriction is above specification

Inspect the air intake system for restriction. Replace the air filter. Refer to Procedure 010-059 (Air Cleaner Restriction) in Section 4 and Procedure 010-060 (Air Cleaner Element, Single Heavy Duty Dry Type) in Section 6.

OK

Go To Next Step

STEP 6

Exhaust system restriction is **not** within specification

Check the exhaust system for restrictions. Contact a Cummins Authorized Repair Facility.

OK

Go To Next Step

STEP 7

Ignition system is malfunctioning or misfiring

Check the ignition system. Refer to Procedure 013-016 (Spark Plugs) in Section 5 and Procedure 013-014 (Spark Plug Wire) in Section 6. If the problem persists contact a Cummins Authorized Repair Facility.

Engine Decelerates Slowly

Cause

Correction

STEP 1

Electronic control module system calibration is not correct

Compare the calibration in the electronic control system with the engine rating and the Control Parts List (CPL), Bulletin number 3379133 or 4021327. If necessary, calibrate the system. Refer to a Cummins Authorized Repair Facility.

OK

Go To Next Step

STEP 2

Throttle plate is malfunctioning

Check the throttle plate for sticking or hysteresis. Refer to a Cummins Authorized Repair Facility.

Engine Difficult to Start or Will Not Start

Cause

Correction

STEP 1
OEM manual fuel shutoff valve is closed

Check the OEM fuel shutoff valves. Verify that the fuel tanks are open.

OK

Go To Next Step

STEP 2
Engine cranking speed is too slow

If the cranking speed is slower than 150 rpm, refer to the Engine Will Not Crank or Cranks Slowly symptom tree.

OK

Go To Next Step

STEP 3
Air intake system restriction is above specification

Inspect the air intake system for restriction. Replace the air filter. Refer to Procedure 010-059 (Air Cleaner Restriction) in Section 4 and Procedure 010-060 (Air Cleaner Element, Single Heavy Duty Dry Type) in Section 6.

OK

Go To Next Step

STEP 4
Engine-driven units are engaged

Disengage engine-driven units.

OK

Go To Next Step

STEP 5
Starting procedure is **not** correct

Verify the correct starting procedure. Refer to Procedure 101-014 (Normal Starting Procedure) in Section 1.

Engine Noise Excessive

Cause

Correction

<p>STEP 1 Lubricating oil pressure is below specification</p>	<p>Check the oil pressure. If the pressure is low, refer to the Lubricating Oil Pressure Low symptom tree.</p>
<p>OK Go To Next Step</p>	
<p>STEP 2 Coolant temperature is above specification</p>	<p>Refer to the Coolant Temperature is Above Normal symptom tree.</p>
<p>OK Go To Next Step</p>	
<p>STEP 3 Fan drive belt is loose, tight, or not in alignment</p>	<p>Check the fan drive belt. Refer to Section Procedure 008-087 (Cooling Fan Belt Tensioner) in Section 5 and Procedure 008-002 (Drive Belts) in Section 7.</p>
<p>OK Go To Next Step</p>	
<p>STEP 4 Engine mounts are worn, damaged, or not correct</p>	<p>Check the engine mounts. Refer to the OEM service manual.</p>
<p>OK Go To Next Step</p>	
<p>STEP 5 Ignition system is malfunctioning or misfiring</p>	<p>Check the ignition system. Refer to Procedure 013-016 (Spark Plugs) in Section 5 and Procedure 013-014 (Spark Plug Wire) in Section 6. If the problem persists contact a Cummins Authorized Repair Facility.</p>
<p>OK Go To Next Step</p>	
<p>STEP 6 Overhead adjustments are not correct</p>	<p>Measure and adjust the overhead settings. Refer to Procedure 003-004 (Overhead Set) in Section 4.</p>

Engine Power Output Low

Cause	Correction
<p>STEP 1 Verify the complaint</p>	<p>Test the engine operation while under load. Perform an engine acceleration test. Perform an engine load/install test. Refer to the OEM installation instructions.</p>
<p>OK Go To Next Step</p>	
<p>STEP 2 Load is excessive for engine horsepower rating</p>	<p>Reduce the load on the engine. Refer to OEM specifications.</p>
<p>OK Go To Next Step</p>	
<p>STEP 3 Engine is misfiring</p>	<p>Refer to the Engine Runs Rough or Misfires symptom tree.</p>
<p>OK Go To Next Step</p>	
<p>STEP 4 Air intake or exhaust leaks</p>	<p>Check for loose or damaged piping connections and missing pipe plugs. Check the turbocharger and exhaust manifold mounting. Refer to the OEM service manual.</p>
<p>OK Go To Next Step</p>	
<p>STEP 5 Air intake system restriction is above specification</p>	<p>Check the air intake system for restriction. Clean or replace the air filter and inlet piping as necessary. Refer to Procedure 010-059 (Air Cleaner Restriction) in Section 4 and Procedure 010-060 (Air Cleaner Element, Single Heavy Duty Dry Type) in Section 6.</p>
<p>OK Go To Next Step</p>	
<p>STEP 6 Low or no fuel pressure at the fuel filter (primary pressure)</p>	<p>Increase output pressure from the primary regulator. Refer to a Cummins Authorized Repair Facility.</p>
<p>OK Go To Next Step</p>	
<p>STEP 7 Low or no fuel pressure at the fuel filter (secondary pressure)</p>	<p>Increase output pressure from the secondary regulator. Refer to a Cummins Authorized Repair Facility.</p>

Engine Runs Rough at Idle

Cause

Correction

STEP 1

Engine mounts are worn, damaged, or **not** correct

Inspect the engine mounts. Replace as needed. Refer to a Cummins Authorized Repair Facility.

OK

Go To Next Step

STEP 2

Ignition system is malfunctioning or misfiring

Check the ignition system. Refer to Procedure 013-016 (Spark Plugs) in Section 5 and Procedure 013-014 (Spark Plug Wire) in Section 6. If the problem persists contact a Cummins Authorized Repair Facility.

OK

Go To Next Step

STEP 3

Intake air restricted

Inspect and change air cleaner. Look for other restrictions. Refer to Procedure 010-059 (Air Cleaner Restriction) in Section 4 and Procedure 010-060 (Air Cleaner Element, Single Heavy Duty Dry Type) in Section 6.

OK

Go To Next Step

STEP 4

Overhead adjustments are **not** correct

Measure and adjust the overhead settings. Refer to Procedure 003-004 (Overhead Set) Section 4.

Engine Runs Rough or Misfires

Cause

Correction

STEP 1
Fuel leak

Check the fuel lines, fuel connections, and fuel filters for leaks using the combustible gas detector service tool. Refer to Procedure 006-063 (Fuel Filter) in Section 6. If the leak persists contact a Cummins Authorized Repair Facility.

OK

Go To Next Step

STEP 2
Ignition system is malfunctioning or misfiring

Check the ignition system. Refer to Procedure 013-016 (Spark Plugs) in Section 5 and Procedure 013-014 (Spark Plug Wire) in Section 6. If the problem persists contact a Cummins Authorized Repair Facility.

Engine Speed Surges at Low or High Idle

Cause

Correction

STEP 1
Engine is cold

Allow the engine to warm up for approximately 1 to 3 minutes. Refer to Procedure 101-999 (Operating Instructions) in Section 1.

OK
Go To Next Step

STEP 2
Fuel leak

Check the fuel lines, fuel connections, and fuel filters for leaks using the combustible gas detector service tool. Refer to Procedure 006-063 (Fuel Filter) in Section 6. If the leak persists contact a Cummins Authorized Repair Facility.

OK
Go To Next Step

STEP 3
Ignition system is malfunctioning or misfiring

Check the ignition system. Refer to Procedure 013-016 (Spark Plugs) in Section 5 and Procedure 013-014 (Spark Plug Wire) in Section 6. If the problem persists contact a Cummins Authorized Repair Facility.

Engine Starts But Will Not Keep Running

Cause

Correction

STEP 1
Manual fuel valve closed

Open manual fuel valve.

OK
Go To Next Step

STEP 2
Load is excessive for engine horsepower rating

Reduce the load on the engine. Refer to OEM specifications.

OK
Go To Next Step

STEP 3
Air intake system restriction is above specification

Inspect the air intake system for restriction. Replace the air filter. Refer to Procedure 010-059 (Air Cleaner Restriction) in Section 4 and Procedure 010-060 (Air Cleaner Element, Single Heavy Duty Dry Type) in Section 6.

OK
Go To Next Step

STEP 4
Exhaust system restriction is **not** within specification

Check the exhaust system for restrictions. Contact a Cummins Authorized Repair Facility.

OK
Go To Next Step

STEP 5
Fuel supply pressure is below specification

Measure the fuel supply pressure. Refer to a Cummins Authorized Repair Facility.

OK
Go To Next Step

STEP 6
Low or no fuel pressure at the mixer (secondary pressure)

Increase output pressure from the secondary regulator.

Engine Transient Response Poor

Cause

Correction

STEP 1
Fuel leak

Check the fuel lines, fuel connections, and fuel filters for leaks using the combustible gas detector service tool. Refer to Procedure 006-063 (Fuel Filter) in Section 6. If the leak persists contact a Cummins Authorized Repair Facility.

OK
Go To Next Step

STEP 2
Load is excessive for engine horsepower rating

Reduce the load on the engine. Refer to OEM specifications.

OK
Go To Next Step

STEP 3
Air intake or exhaust leaks

Check for loose or damaged piping connections and missing pipe plugs. Check the turbocharger and exhaust manifold mounting. Refer to the OEM service manual.

OK
Go To Next Step

STEP 4
Air intake system restriction is above specification

Inspect the air intake system for restriction. Replace the air filter. Refer to Procedure 010-059 (Air Cleaner Restriction) in Section 4 and Procedure 010-060 (Air Cleaner Element, Single Heavy Duty Dry Type) in Section 6.

OK
Go To Next Step

STEP 5
Exhaust system restriction is **not** within specification

Check the exhaust system for restrictions. Contact a Cummins Authorized Repair Facility.

OK
Go To Next Step

STEP 6
Ignition system is malfunctioning or misfiring

Check the ignition system. Refer to Procedure 013-016 (Spark Plugs) in Section 5 and Procedure 013-014 (Spark Plug Wire) in Section 6. If the problem persists contact a Cummins Authorized Repair Facility.

OK
Go To Next Step

STEP 7
Low or no fuel pressure at the fuel filter (primary pressure)

Increase output pressure from the primary regulator. Refer to a Cummins Authorized Repair Facility.

OK
Go To Next Step

STEP 8
Low or no fuel pressure at the fuel filter (secondary pressure)

Increase output pressure from the secondary regulator. Refer to a Cummins Authorized Repair Facility.

Engine Vibration Excessive

Cause

Correction

STEP 1
Engine is misfiring

Refer to the Engine Runs Rough or Misfires symptom tree.

OK
Go To Next Step

STEP 2
Fan is loose, damaged, or **not** balanced

Check the fan. Refer to Procedure 008-040 (Fan, Cooling) in Section 3.

OK
Go To Next Step

STEP 3
Engine mounts are worn, damaged, or **not** correct

Check the engine mounts. Refer to Procedure 016-010 (Engine Mounts) in Section 6.

Engine Will Not Crank or Cranks Slowly (Air Starter)

Cause

Correction

STEP 1
Starting procedure is **not** correct

Verify the correct starting procedure. Refer to Procedure 101-014 (Cold Weather Starting) in Section 1.

OK
Go To Next Step

STEP 2
Crankshaft rotation is impaired

Check the crankshaft for ease of rotation. Refer to Procedure 101-018 (Starting Procedure After Extended Shutdown or Oil Change) in Section 1.

OK
Go To Next Step

STEP 3
Starting air pressure low

Check that the air supply valve is open completely. Check the air compressor for proper operation.

OK
Go To Next Step

STEP 4
Starting circuit component is malfunctioning

Check the starting circuit components. Refer to the OEM service manual.

Engine Will Not Reach Rated Speed (RPM)

Cause

Correction

STEP 1

Load is excessive for engine horsepower rating

Reduce the load on the engine. Refer to OEM specifications.

OK

Go To Next Step

STEP 2

Tachometer is **not** calibrated or is malfunctioning

Compare the tachometer reading with a handheld tachometer or an electronic service tool reading. Calibrate or replace the tachometer as necessary. Refer to the OEM service manual.

OK

Go To Next Step

STEP 3

Air intake or exhaust leaks

Check for loose or damaged piping connections and missing pipe plugs. Check the turbocharger and exhaust manifold mounting. Refer to the OEM Service Manual.

OK

Go To Next Step

STEP 4

Air intake system restriction is above specification

Inspect the air intake system for restriction. Replace the air filter. Refer to Procedure 010-059 (Air Cleaner Restriction) in Section 4 and Procedure 010-060 (Air Cleaner Element, Single Heavy Duty Dry Type) in Section 6.

OK

Go To Next Step

STEP 5

Engine power output is low

Refer to the Engine Power Output Low symptom tree.

OK

Go To Next Step

STEP 6

Fuel leak

Check the fuel lines, fuel connections, and fuel filters for leaks using the combustible gas detector service tool. Refer to Procedure 006-063 (Fuel Filter) in Section 6. If the leak persists contact a Cummins Authorized Repair Facility.

OK

Go To Next Step

STEP 7

Ignition system is malfunctioning or misfiring

Check the ignition system. Refer to Procedure 013-016 (Spark Plugs) in Section 5 and Procedure 013-014 (Spark Plug Wire) in Section 6. If the problem persists contact a Cummins Authorized Repair Facility.

OK

Go To Next Step

STEP 8

Fuel supply pressure is below specification

Measure the fuel supply pressure. Refer to a Cummins Authorized Repair Facility.

OK

Go To Next Step

Engine Will Not Reach Rated Speed (RPM)

Cause

Correction

STEP 9

Low or no fuel pressure at the mixer (secondary pressure)

Increase output pressure from the secondary regulator.

Faint, illegible text in the cause box area.

Faint, illegible text in the correction box area.



Engine Will Not Shut Off

Cause

Correction

STEP 1

Stop/Run switch circuit is malfunctioning

Check the Stop/Run switch circuit. Refer to the OEM service manual.

OK

Go To Next Step

STEP 2

Engine is running on fumes drawn into the air intake

Check the air intake ducts. Locate and isolate the source of the fumes. Repair as necessary. Refer to the OEM installation and service manual.

Fuel Consumption Excessive

Cause

Correction

<p>STEP 1 Verify the complaint</p> <p>OK Go To Next Step</p>	<p>Refer to the engine datasheet. Compare the fuel usage records with the engine datasheet.</p>
<p>STEP 2 Fuel leak</p> <p>OK Go To Next Step</p>	<p>Check the fuel lines, fuel connections, and fuel filters for leaks using the combustible gas detector service tool. Refer to Procedure 006-063 (Fuel Filter) in Section 6. If the leak persists contact a Cummins Authorized Repair Facility.</p>
<p>STEP 3 Load is excessive for engine horsepower rating</p> <p>OK Go To Next Step</p>	<p>Reduce the load on the engine. Refer to OEM specifications.</p>
<p>STEP 4 Fuel consumption has increased after an engine repair</p> <p>OK Go To Next Step</p>	<p>Evaluate the engine repair to determine its effect on fuel consumption. Check part numbers to make sure the correct parts were used. Refer to the Control Parts List (CPL), Bulletin Number 4021326 or 4021326.</p>
<p>STEP 5 Exhaust system restriction is not within specification</p> <p>OK Go To Next Step</p>	<p>Check the exhaust system for restrictions. Contact a Cummins Authorized Repair Facility.</p>
<p>STEP 6 Air intake system restriction is above specification</p> <p>OK Go To Next Step</p>	<p>Check the air intake system for restriction. Clean or replace the air filter and inlet piping as necessary. Refer to Procedure 010-059 (Air Cleaner Restriction) in Section 4 and Procedure 010-060 (Air Cleaner Element, Single Heavy Duty Dry Type) in Section 6.</p>
<p>STEP 7 Ignition system is malfunctioning or misfiring</p>	<p>Check the ignition system. Refer to Procedure 013-016 (Spark Plugs) in Section 5 and Procedure 013-014 (Spark Plug Wire) in Section 6. If the problem persists contact a Cummins Authorized Repair Facility.</p>

Lubricating Oil Consumption Excessive

Cause

Correction

STEP 1
Lubricating oil leak (external)

Inspect the engine for external oil leaks. Tighten the capscrews, pipe plugs, and fittings. Replace gaskets, if necessary. Refer to Procedure 018-009 (Capscrew Markings and Torque Values) in Section V torque for specifications.

OK
Go To Next Step

STEP 2
Lubricating oil level is above or below specification

Check the oil level. Add or drain oil, if necessary. Refer to Procedure 007-043 (Lubricating Oil Level) in Section 3 and Procedure 007-002 (Lubricating Oil and Filters) in Section 4.

OK
Go To Next Step

STEP 3
Engine is cold

Allow the engine to warm to operating temperature. If the engine will **not** reach operating temperature, refer to the Coolant Temperature Below Normal symptom tree.

OK
Go To Next Step

STEP 4
Lubricating oil does **not** meet specifications for operating conditions

Change the oil and filters. Refer to Procedure 007-002 (Lubricating Oil and Filters) in Section 4. Use the oil recommended in Section V.

Lubricating Oil Pressure High

Cause

Correction

STEP 1

Lubricating oil pressure switch, gauge, or sensor is malfunctioning or is **not** in the correct location

Check the oil pressure switch, gauge, or sensor for correct operation and location. Refer to the OEM service manual.

OK

Go To Next Step

STEP 2

Coolant temperature is below specification

Refer to the Coolant Temperature Below Normal symptom tree.

OK

Go To Next Step

STEP 3

Lubricating oil does **not** meet specifications for operating conditions

Change the oil and filters. Refer to Procedure 007-002 (Lubricating Oil and Filters) in Section 4. Use the oil type recommended in Section V.

Lubricating Oil Pressure Low

Cause

Correction

STEP 1

Lubricating oil level is above or below specification

Check the oil level. Add or drain oil if necessary. Refer to Procedure 007-043 (Lubricating Oil Level) in Section 3 and Procedure 007-002 (Lubricating Oil and Filters) in Section 4. Check the dipstick calibration.

OK

Go To Next Step

STEP 2

Lubricating oil pressure switch, gauge, or sensor is malfunctioning or is **not** in the correct location

Check the oil pressure switch, gauge, or sensor for correct operation and location. Refer to the OEM service manual.

OK

Go To Next Step

STEP 3

Lubricating oil does **not** meet specifications for operating conditions

Change the oil and filters. Refer to Procedure 007-002 (Lubricating Oil and Filters) in Section 4.

OK

Go To Next Step

STEP 4

Lubricating oil temperature is above normal (120° C [248°F])

Refer to the Coolant Temperature Above Normal symptom tree.

Lubricating Oil Sludge in the Crankcase Excessive
Cause Correction

STEP 1
Lubricating oil drain interval is excessive

Verify the correct lubricating oil drain interval. Refer to Procedure (Maintenance Schedule) in Section 2.

OK
Go To Next Step

STEP 2
Engine is cold

Allow the engine to warm to operating temperature. If the engine will **not** reach operating temperature, refer to the Coolant Temperature Below Normal symptom tree.

OK
Go To Next Step

STEP 3
Lubricating oil does **not** meet specifications for operating conditions

Change the oil and filters. Refer to Procedure 007-002 (Lubricating Oil and Filters) in Section 4. Use the oil type recommended in Section V.

OK
Go To Next Step

STEP 4
Bulk oil supply is contaminated

Check the bulk oil supply. Drain the oil and replace with noncontaminated oil. Replace the oil filter(s).

Lubricating Oil Temperature Above Specification

Cause

Correction

STEP 1

Coolant temperature is above specification

Refer to the Coolant Temperature Above Normal symptom tree.

OK

Go To Next Step

STEP 2

Lubricating oil level is above or below specification

Check the oil level. Add or drain oil, if necessary. Refer to Procedure 007-043 (Lubricating Oil Level) in Section 3 and Procedure 007-002 (Lubricating Oil and Filters) in Section 4.

OK

Go To Next Step

STEP 3

Lubricating oil pressure sensor or gauge is malfunctioning or is **not** in the correct location

Check the oil pressure switch or gauge for correct operation and location. Refer to the OEM service manual for proper operation and the OEM installation instructions for proper location of pressure gauge or sensor.

Section V - Maintenance Specifications

Section Contents

	Page
Air Intake System	V-5
Specifications.....	V-5
Capscrew Markings and Torque Values	V-18
Capscrew Markings and Torque Values - Metric.....	V-18
Capscrew Markings and Torque Values - U.S. Customary.....	V-18
General Information.....	V-18
Coolant Recommendations and Specifications	V-11
Coolant Replacement Requirements.....	V-15
Cooling System Sealing Additives.....	V-13
Cooling System Soluble Oils.....	V-13
Fully Formulated Coolant/Antifreeze.....	V-11
General Information.....	V-11
Supplemental Coolant Additive (SCA).....	V-13
Test Intervals.....	V-14
Testing SCA Concentration Level CC-2602 Test Kit.....	V-14
Cooling System	V-4
Specifications.....	V-4
C8.3G and C Gas Plus.....	V-4
L Gas Plus.....	V-4
Cummins/Fleetguard® Filter Specifications	V-8
General Information.....	V-8
Electrical System	V-7
Specifications.....	V-7
Engine Component Torque Values	V-16
Component List.....	V-16
Exhaust System	V-6
Specifications.....	V-6
Fuel System	V-2
Specifications.....	V-2
General Engine	V-1
Specifications.....	V-1
C8.3G and C Gas Plus.....	V-1
L Gas Plus.....	V-1
Lubricating Oil Recommendations and Specifications	V-9
General Information.....	V-9
Lubricating Oil System	V-3
Specifications.....	V-3
C8.3G and C Gas Plus.....	V-3
L Gas Plus.....	V-3
Sealants	V-17
General Information.....	V-17

Section V - Maintenance Specifications

Section V - Maintenance Specifications

1-1

1-2

1-3

1-4

1-5

1-6

1-7

1-8

1-9

1-10

1-11

1-12

1-13

1-14

1-15

1-16

1-17

1-18

1-19

1-20

1-21

1-22

1-23

1-24

1-25

1-26

1-27

1-28

1-29

1-30

1-31

1-32

1-33

1-34

1-35

This Page Left Intentionally Blank

General Engine

Specifications

C8.3G and C Gas Plus

For horsepower and engine speed at maximum output values, refer to the engine data sheet for the particular model involved.

Bore and Stroke.....	114 mm [4.49 in] x 135 mm [5.32 in]
Displacement.....	8.3 liters [504.5 C.I.D.]
Compression Ratio:.....	8.5:1 and 10.5:1
Firing Order.....	1-5-3-6-2-4
Horsepower:.....	Check engine dataplate for engine horsepower information.
Governed Speed:.....	Check engine dataplate for engine governed speed information.
Idle Speed:.....	Check engine dataplate for engine idle speed information.
Torque:.....	365 lb ft
Engine Weight:	
Dry (fan hub to flywheel).....	721 kg [1590 lb]
Wet (fan hub to flywheel).....	748 kg [1650 lb]
Crankshaft Rotation (viewed from the front of the engine).....	Clockwise

L Gas Plus

For horsepower and engine speed at maximum output values, refer to the engine data sheet for the particular model involved.

Bore and Stroke.....	114 mm [4.49 in] x 144.5 mm [5.69 in]
Displacement.....	8.9 liters [540.2 C.I.D.]
Firing Order.....	1-5-3-6-2-4
Crankshaft Rotation (viewed from the front of the engine).....	Clockwise

Fuel System

Specifications

Gas pressure to engine-mounted regulator (water column at full load):	254 to 508 mm [10 to 20 in]
Gas pressure to carburetor (water column at full load):	102 to 452 mm [4 to 6 in]
Ignition Timing and Exhaust Oxygen Content:	
G8.3 - Degrees Before Top Dead Center	26
G8.3 - Excess O ₂ Percent (Standby - Maximum)	0.5
G8.3 - Excess O ₂ Percent (Prime - Continuous)	2.6
GTA8.3 - Degrees Before Top Dead Center	30
GTA8.3 - Excess O ₂ Percent (Standby - Maximum)	6.1
GTA8.3 - Excess O ₂ Percent (Prime - Continuous)	6.1
Application Derates: Altitude, Ambient Air:	
Application(s): Industrial, Generator	
Power Rating:	Maximum, Standby and Continuous, Prime
Maximum Altitude (ft.) w/o Derate:	
G8.3 - Maximum, Standby	500
G8.3 - Continuous, Prime	1500
GTA8.3 - Maximum, Standby (High Compression Ratio)	3000
GTA8.3 - Maximum, Standby (Low Compression Ratio)	3000
GTA8.3 - Continuous, Prime (High Compression Ratio)	5000
GTA8.3 - Continuous, Prime (Low Compression Ratio)	5000
Maximum Ambient - Intake Manifold Temperature, w/o Derate:	
G8.3 - Maximum, Standby	30°C [85°F]
G8.3 - Continuous, Prime	38°C [100°F]
GTA8.3 - Maximum, Standby (High Compression Ratio)	52°C [125°F]
GTA8.3 - Maximum, Standby (Low Compression Ratio)	60°C [140°F]
GTA8.3 - Continuous, Prime (High Compression Ratio)	52°C [125°F]
GTA8.3 - Continuous, Prime (Low Compression Ratio)	60°C [140°F]

Lubricating Oil System

Specifications

C8.3G and C Gas Plus

Oil Pressure:	
Low Idle (minimum allowable).....	70 kPa [10 psi]
At 1400 rpm or Torque Peak (minimum allowable).....	207 kPa [30 psi]
Oil Capacity:	
Standard Oil Pan.....	15 to 19 liter [4.0 to 5.0 gal]
High Capacity Oil Pan:.....	22.7 to 35 liter [6.0 to 9.25 gal]
Total System Capacity Including Filters:	
Standard Oil Pan:.....	23.8 liter [6.3 gal]
High Capacity Oil Pan:.....	39.9 liter [10.55 gal]
Maximum Allowable Oil Temperature:.....	127°C [260°F]

L Gas Plus

Oil Pressure:	
Low Idle (minimum allowable).....	70 kPa [10 psi]
At 1400 rpm or Torque Peak (minimum allowable).....	207 kPa [30 psi]

Cooling System

Specifications

C8.3G and C Gas Plus

Coolant Capacity (engine only):	10.9 liter [11.5 qt.]
Standard Modulating Thermostat Range:	81° to 95°C [181° to 203°F]
Minimum Allowable Pressure Cap:	
104°C [220°F] System:	103 kPa [15 psi]
Operating Temperatures:	
Minimum Recommended:	70°C [158°F]
Maximum Allowable:	100°C [212°F]

L Gas Plus

Standard Modulating Thermostat Range:	81° to 95°C [181° to 203°F]
Operating Temperatures:	
Minimum Recommended:	70°C [158°F]
Maximum Allowable:	100°C [212°F]

Air Intake System

Specifications

All measurements are while engine is under rated conditions.....	6 kPa [25 in H ₂ O]
Maximum Intake Air Restriction:	
With Dirty Filter Element.....	6 kPa [25 in H ₂ O]
With Normal-Duty Air Cleaner and Clean Air Filter Element.....	2 kPa [10 in H ₂ O]
With Heavy-Duty Air Cleaner and Clean Air Filter Element.....	4 kPa [15 in H ₂ O]

Exhaust System

Specifications

Maintain the following limits during a chassis dynamometer test:

Maximum Exhaust Back Pressure:.....	50 mm Hg [2.0 in Hg]
Exhaust Outlet Pipe Size:.....	89 mm [3.5 in]
Maximum Turbine Inlet Temperature (dry manifold).....	726°C [1375°F]

Electrical System

Specifications

Minimum Recommended Battery Capacity (Cold soak —18°C [0°F] or above).....	24-VDC
Engine Only:	
Cold Cranking Amps.....	900
Reserve Capacity (minimum).....	320
Engine Loaded:	
Cold Cranking Amps.....	900
Reserve Capacity (minimum).....	320
Maximum Allowable Resistance to Starting Circuit (Ohms).....	.002 Ohms
Starting Circuit	
Maximum Resistance	
12-VDC Starter.....	0.0012 ohm
24-VDC Starter.....	0.0040 ohm

Minimum Recommended Battery Capacity				
System Voltage	Ambient Temperature: -18°C [0°F]		Ambient Temperature: 0°C [32°F]	
	Cold Cranking Amperes	Reserve Capacity ¹ Amperes	Cold Cranking Amperes	Reserve Capacity ¹ Amperes
12-VDC	1800	640	1280	480
24-VDC ²	900	320	640	240

1. The number of plates within a given battery size determines reserve capacity. Reserve capacity determines the length of time that sustained cranking can occur.
2. CCA ratings are based on two 12-VDC batteries in series.

Lubricating Oil Recommendations and Specifications

General Information

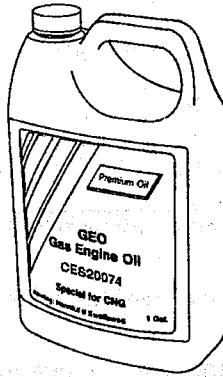

07900244

▲ CAUTION ▲

Do not use L10G engine oil in the B5.9G, B Gas Plus, B5.9LPG, B LPG Plus, C8.3G, C Gas Plus and L Gas Plus engines. If L10G engine lubricating oil is used, failure of the tappets and camshaft will occur.

▲ CAUTION ▲

Do not use diesel engine oil in a natural gas engine. If diesel engine oil is used, valve torching, piston scuffing, and reduction of spark plug life will occur.

▲ CAUTION ▲

A sulfated ash limit of 0.6 percent has been placed on all engine lubricating oil recommended for use in Cummins natural gas engines. Higher ash oils can cause valve and/or piston damage and lead to excessive oil consumption and degradation of the catalyst.

Cummins® natural gas engines require a special oil that is available from major oil suppliers. Careful attention **must** be paid to engine oil specifications because natural gas engine oil has different properties than a diesel engine oil.

The oil specification for the B5.9G, B Gas Plus, B5.9LPG, B LPG Plus, C8.3G, C Gas Plus and L Gas Plus engines is **not** the same as the L10G engine lubricating oil specification.

B5.9G, B Gas Plus, B5.9LPG, B LPG Plus, C8.3G, C Gas Plus and L Gas Plus engines **must** use oil that conforms to Cummins Engineering Standards (CES) 20074. This standard will be identified on the supplier's oil packaging. If in doubt whether the oil meets the Cummins specification, contact the supplier to obtain a copy of the Cummins registration letter that certifies the oil meets specifications.

For easy identification, the packaging of the oil will show CES20074 upon it.

For further assistance contact an authorized Cummins repair location, which can supply information regarding oil brands that comply with Cummins specifications.

Correct engine lubricating oil and filter change intervals **must** be maintained for each specific Cummins engine model. A sharp increase in component wear and damage can occur if lubricating oil and filter maintenance intervals are **not** followed as outlined in the maintenance schedule in Section 2.

Quality engine lubricating oils combined with appropriate oil and filter change intervals are critical factors in maintaining engine performance and durability.

Special "break-in" engine lubricating oils are **not** recommended for new or rebuilt Cummins natural gas engines. During "break-in", use the same lubricating oil that will be used in normal engine operation.

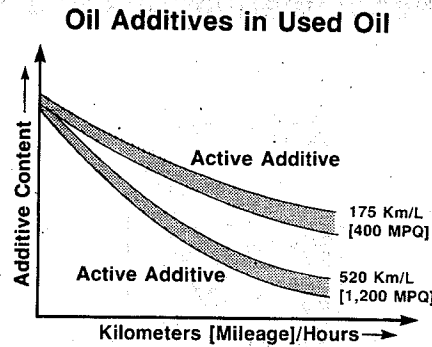

oi8guvb

As the engine oil becomes contaminated, essential oil additives are depleted. Lubricating oils protect the engine as long as these additives are functioning properly.

Progressive contamination of the oil between oil and filter change intervals is normal. The amount of contamination will vary depending on the operation of the engine, distance on the oil, fuel consumed, and new oil added.

NOTE: Oil for natural gas engines does **not** darken and look dirty as diesel oil does. Use the maintenance schedule in Section 2 to determine the oil change interval requirement, **not** the oil's appearance.

Additional information regarding lubricating oil availability throughout the world is available in the E.M.A. Lubricating Oils Data Book for Heavy-Duty Automotive and Industrial Engines. The data book can be ordered from the following:

Engine Manufacturers Association
2 North LaSalle Street
Suite 2200
Chicago, IL, U.S.A. 60602
Phone 1-312-827-8700

For further details and discussion of engine lubricating oils for Cummins engines, refer to Bulletin 3810340, Cummins Engine Oil Recommendations.

Coolant Recommendations and Specifications

General Information

Cummins Inc. recommends the use of fully-formulated antifreeze or coolant containing a pre-charge of Supplemental Coolant Additive (SCA). The use of fully formulated antifreeze or coolant significantly simplifies cooling system maintenance.

Fully-formulated antifreeze contains balanced amounts of antifreeze, SCA, and buffering compounds, but does **not** contain 50 percent water.

Fully-formulated coolant contains balanced amounts of antifreeze, SCA, and buffering compounds already premixed 50 to 50 with deionized water.

The following pages will give an explanation of water, antifreeze, and SCA's. They will also explain how to test antifreeze and SCA levels.

Alternative maintenance practices for cooling systems can be found in Cummins Coolant Requirements and Maintenance, Bulletin 3666132.

Fully Formulated Coolant/Antifreeze

Cummins Inc. recommends using either a 50 to 50 mixture of high quality water and fully formulated antifreeze, or fully formulated coolant when filling the cooling system.

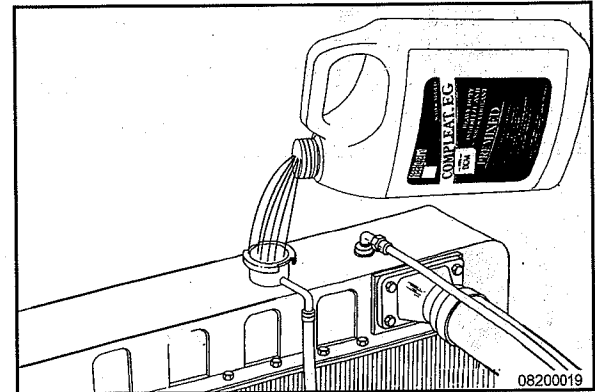

High quality water is important for cooling system performance. Excessive levels of calcium and magnesium contribute to scaling problems, and excessive levels of chlorides and sulfates cause cooling system corrosion.

Water Quality	
Calcium Magnesium (Hardness)	Maximum 170 ppm as (CaCO ₃ + MgCO ₃)
Chloride	40 ppm as(Cl)
Sulfur	100 ppm as (SO ₄)

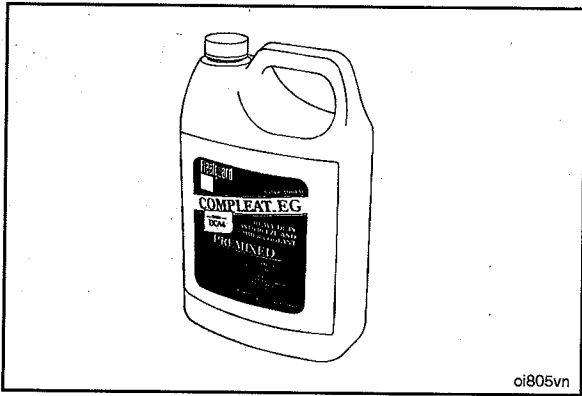

oi805vn

Cummins Inc. recommends using Fleetguard® Compleat. It is available in both glycol forms (ethylene and propylene).

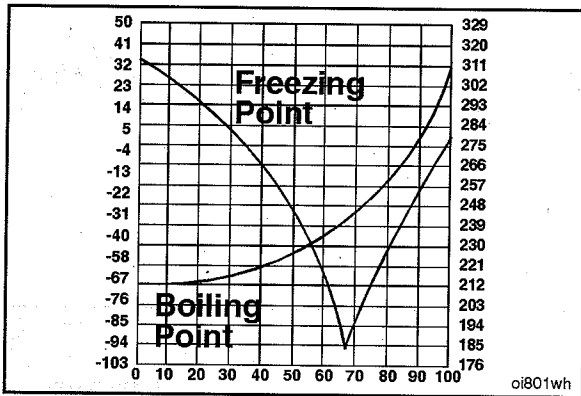

oi801wh

Fully-formulated antifreeze **must** be mixed with high quality water at a 50 to 50 ratio (40 to 60 percent working range). A 50 to 50 mixture of antifreeze and water gives a -36°C [-34°F] freeze point and a boiling point of 110°C [228°F], which is adequate for all locations. The actual lowest freeze point of ethylene glycol antifreeze is at 69 percent. Using higher concentrations of antifreeze will raise the freeze point of the solution and increase the possibility of a silicate gel problem.

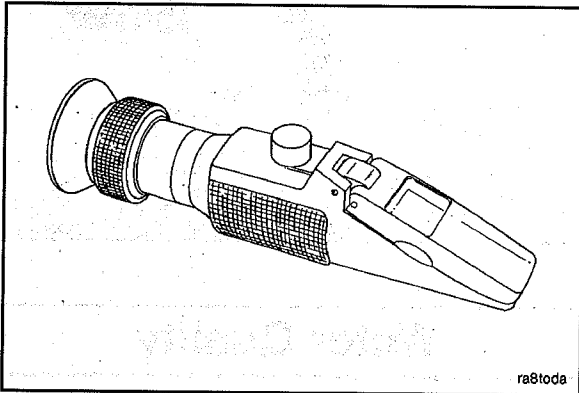

ra8toda



A refractometer, Part Number CC-2800, **must** be used to accurately measure the freeze point of the coolant.

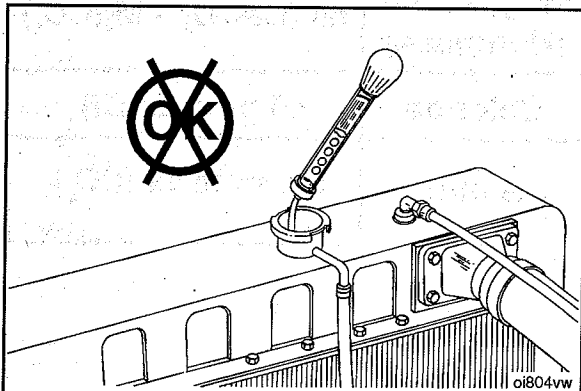

oi804vw

Do **not** use a floating ball hydrometer, as it can give incorrect readings.

Cooling System Sealing Additives

Do **not** use sealing additives in the cooling systems. The use of sealing additives will:

- Build up in coolant low flow areas
- Plug the radiator and oil cooler.

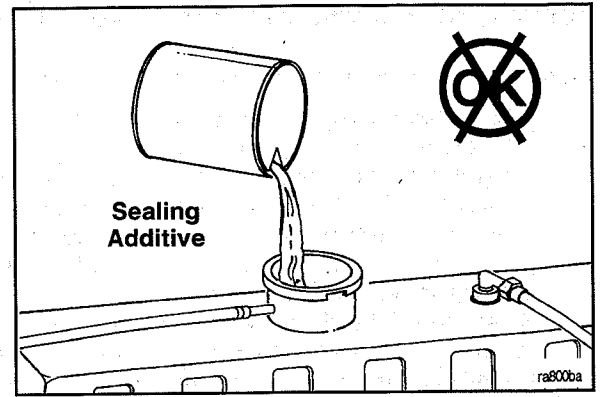

Cooling System Soluble Oils

Do **not** use soluble oils in the cooling system. The use of soluble oils will:

- Allow cylinder liner pitting
- Corrode brass and copper
- Damage heat transfer surfaces
- Damage seals and hoses.

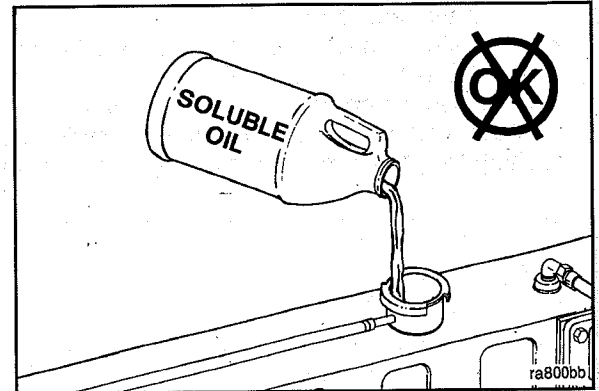

Supplemental Coolant Additive (SCA)

Fully-formulated products contain SCA's and are required to protect the cooling system from fouling, solder blooming, and general corrosion.

Supplemental coolant additives, or equivalent, are used to prevent pitting, corrosion, and scale deposits in the cooling system.

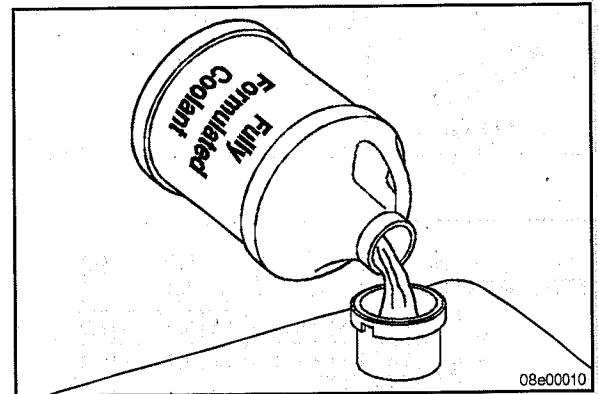

⚠ CAUTION ⚠

Insufficient concentration of the coolant additives will result in cylinder liner pitting, corrosion, solder blooming, and scale deposits which will lead to engine failure.

The SCA concentration **must not** fall below 1.5 units or exceed 3 units per gallon of cooling system capacity.

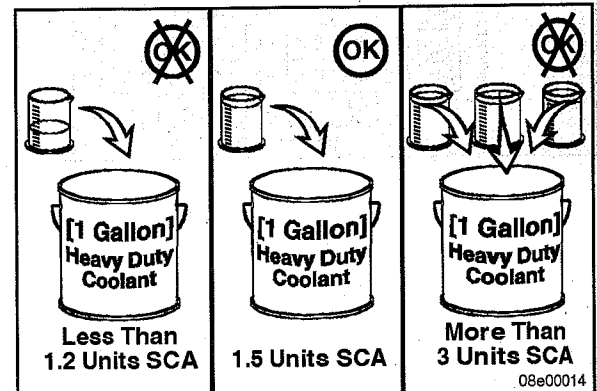

Testing SCA Concentration Level CC-2602 Test Kit

Carefully follow the instructions to test the coolant and take the appropriate action recommended by the kit.

- The coolant sample to be tested **must** be between 10 and 54°C [50 and 130°F]. If the sample is too cold or too hot, the results will be incorrect.
- To get the best color match results, compare test strip pads to the color chart in daylight or under cool white fluorescent lighting. If unsure about a specific color match when a test falls between two colors on the color chart, choose the lower numbered block. It is safer to underestimate results than to overestimate.
- The test strips have a limited shelf life and are sensitive to humidity and extreme heat. Proper handling and storage is necessary to protect the life of the strips.
- Keep the lid tightly sealed on the strip bottle except when removing a strip. Store away from direct sunlight and in an area where the temperature will generally stay below 32°C [90°F].
- Do **not** use the test strips after the expiration date stamped on the bottle.
- Discard the kit if any of the pads on the unused strips have turned light brown or pink.
- Use one strip at a time and take care **not** to touch and pads on the strip. Doing so will contaminate the pads and affect the test results.
- If the strip container is left uncapped for 24 hours, moisture in the air will render the strips useless, although no discoloration will be evident.
- Only use the color chart supplied with the kit.
- Clean and dry the sample cup and syringe after each use. This will prevent contaminating future samples.
- Following the correct test times is very important, use a clock or stopwatch.

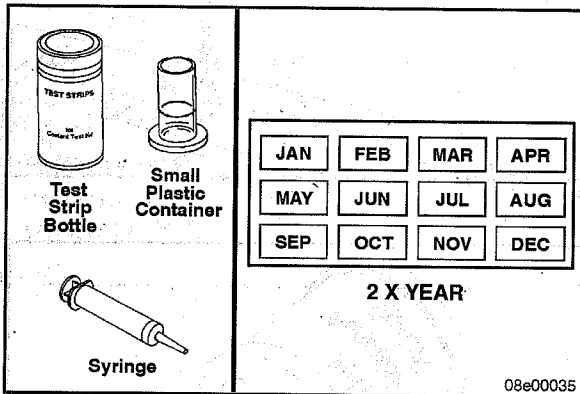

Test Intervals

Testing is recommended if the operator is **not** sure of the cooling system condition due to leaks, uncontrolled topping off of the system, or major coolant loss.

Test the cooling system at a minimum of twice a year to monitor the SCA level. If the SCA level is above 3 units, test at subsequent oil drain intervals until the concentration is back under 3 units.

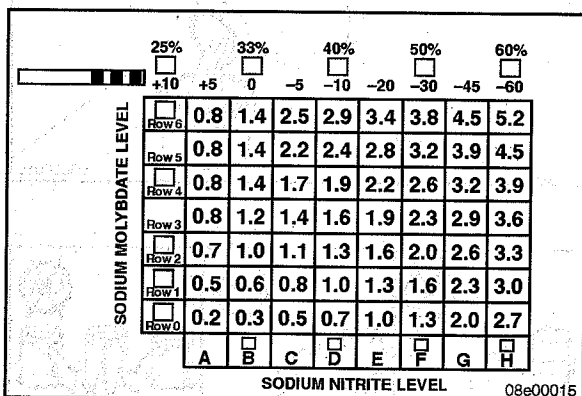

Do **not** use the test kit to maintain minimum SCA concentration levels (i.e. 1.5 units). The recommended SCA level is 1.5 units per gallon.

In some instances the A or B reading can be high. However, it is the combined reading that is important. Therefore, **always** follow the chart.

Part Number Description

CC2602 Works with any SCA formulation (Call 1-800-521-4005 if the color chart does **not** show the number of units of SCA per gallon of coolant.)
Coolant Test Kit

Probablizer:

3318169S Installs on the engine for easy coolant sampling
Plug

3318168S Use with Monitor C bottle to sample coolant
Cap

CC2700 Lab analysis of coolant sample
Monitor C

To get answers to any questions regarding cooling system maintenance, contact a local Cummins authorized repair location.

Coolant Replacement Requirements

NOTE: If the coolant is **not** going to be reused, dispose of in accordance with local environmental regulations.

Drain and flush the cooling system after 15,000 hours or 30 months of service. Refill with either new fully-formulated coolant or a 50 to 50 mixture of high quality water and fully-formulated antifreeze.

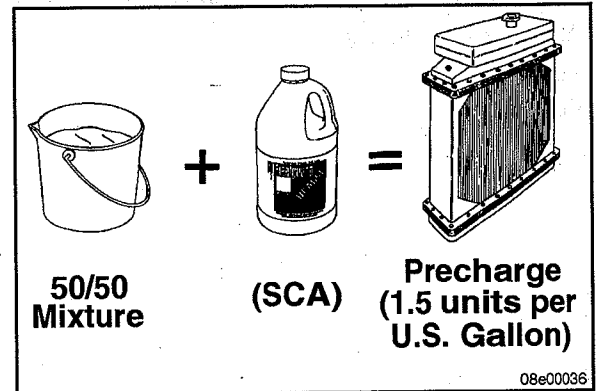

Engine Component Torque Values

Component List

Engine Component Torque List

Component
Oil Pan Drain Plug
Rocker Lever Cover Capscrews
Air Intake Hose Clamps
Spark Plugs
Starter Motor
Turbocharger exhaust and Intake Piping Hose Clamps
Coils to Coil Bracket
Belt Tensioner
Fan Pulley
Thermostat Housing / Water Outlet Connection
Alternator Mounting
Alternator Link
Filters

Torque Values

N•m	ft-lb
80	59
15	130 in-lb
8	72 in-lb
35 to 41	26 to 30
43	32
8	72 in-lb
9	80 in-lb
43	32
24	18
24	18

Refer to the OEM Service Literature

Refer to the OEM Service Literature

Contact plus 1/2 to 3/4 turn

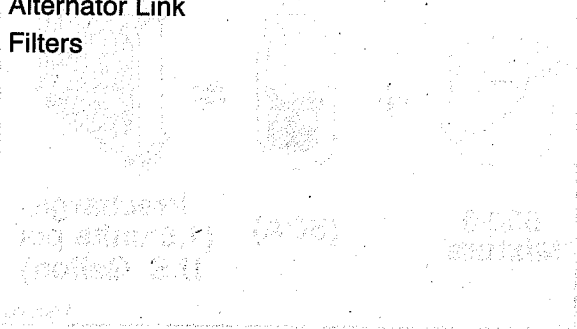

Sealants

General Information

Use the sealants listed below or sealants containing equivalent properties.

Item Description	Sealing Method
Pipe Plugs	Precoated teflon or pipe sealer
Cup Plugs	Loctite 277 or 11,264
O-Rings	Lubriplate™ 105
Rear Camshaft Expansion Plug	Precoated or Loctite 59,241 liquid teflon
Fuel Block Mounting Studs	Loctite 609
Turbocharger Drain in Block	Loctite 277 or 11,264
Front Seal in Gear Cover	Loctite 277 or 11,264
Rear Seal in Rear Cover	No sealant
Oil Pan at T-Joint	Three-Bond™ 1207C (Cummins Part Number 3823494)

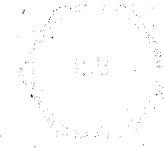
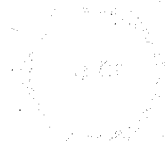
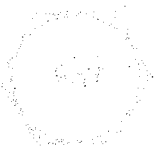

Item	Part No.	Qty	Notes
1	100	1	
2	101	1	
3	102	1	
4	103	1	
5	104	1	
6	105	1	
7	106	1	
8	107	1	
9	108	1	
10	109	1	
11	110	1	
12	111	1	
13	112	1	
14	113	1	
15	114	1	
16	115	1	
17	116	1	
18	117	1	
19	118	1	
20	119	1	
21	120	1	
22	121	1	
23	122	1	
24	123	1	
25	124	1	
26	125	1	
27	126	1	
28	127	1	
29	128	1	
30	129	1	
31	130	1	
32	131	1	
33	132	1	
34	133	1	
35	134	1	
36	135	1	
37	136	1	
38	137	1	
39	138	1	
40	139	1	
41	140	1	
42	141	1	
43	142	1	
44	143	1	
45	144	1	
46	145	1	
47	146	1	
48	147	1	
49	148	1	
50	149	1	
51	150	1	
52	151	1	
53	152	1	
54	153	1	
55	154	1	
56	155	1	
57	156	1	
58	157	1	
59	158	1	
60	159	1	
61	160	1	
62	161	1	
63	162	1	
64	163	1	
65	164	1	
66	165	1	
67	166	1	
68	167	1	
69	168	1	
70	169	1	
71	170	1	
72	171	1	
73	172	1	
74	173	1	
75	174	1	
76	175	1	
77	176	1	
78	177	1	
79	178	1	
80	179	1	
81	180	1	
82	181	1	
83	182	1	
84	183	1	
85	184	1	
86	185	1	
87	186	1	
88	187	1	
89	188	1	
90	189	1	
91	190	1	
92	191	1	
93	192	1	
94	193	1	
95	194	1	
96	195	1	
97	196	1	
98	197	1	
99	198	1	
100	199	1	

Capscrew Markings and Torque Values

General Information



When replacing capscrews, always use a capscrew of the same measurement and strength as the capscrew being replaced. Using the wrong capscrews can result in engine damage.

Metric capscrews and nuts are identified by the grade number stamped on the head of the capscrew or on the surface of the nuts. U.S. Customary capscrews are identified by radial lines stamped on the head of the capscrew.

The following examples indicate how capscrews are identified:

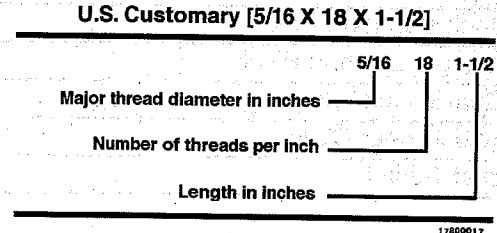
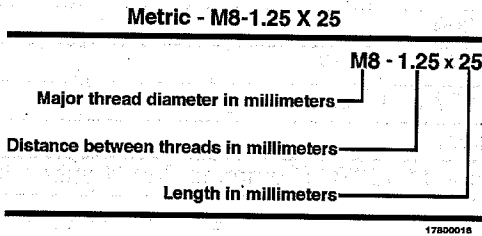

NOTES:

1. Always use the torque values listed in the following tables when specific torque values are not available.
2. Do not use the torque values in place of those specified in other sections of this manual.
3. The torque values in the table are based on the use of lubricated threads.
4. When the ft-lb value is less than 10, convert the ft-lb value to in-lb to obtain a better torque with an in-lb torque wrench. Example: 6 ft-lb equals 72 in-lb.

Capscrew Markings and Torque Values - Metric

Commercial Steel Class

8.8

10.9

12.9

Capscrew Head Markings

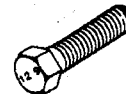
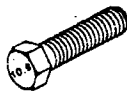
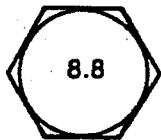
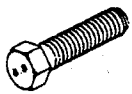

Body Size

Torque

Torque

Torque

Diameter mm	Cast Iron		Aluminum		Cast Iron		Aluminum		Cast Iron		Aluminum	
	N•m	ft-lb	N•m	ft-lb	N•m	ft-lb	N•m	ft-lb	N•m	ft-lb	N•m	ft-lb
6	9	5	7	4	13	10	7	4	14	9	7	4
7	14	9	11	7	18	14	11	7	23	18	11	7
8	23	17	18	14	33	25	18	14	40	29	18	14
10	45	33	30	25	65	50	30	25	70	50	30	25
12	80	60	55	40	115	85	55	40	125	95	55	40
14	125	90	90	65	180	133	90	65	195	145	90	65
16	195	140	140	100	280	200	140	100	290	210	140	100
18	280	200	180	135	390	285	180	135	400	290	180	135
20	400	290	—	—	550	400	—	—	—	—	—	—

Capscrew Markings and Torque Values - U.S. Customary

SAE Grade Number

5

8

Capscrew Head Markings

These are all SAE Grade 5 (3 line)



Capscrew Torque - Grade 5 Capscrew

Capscrew Torque - Grade 8 Capscrew

Capscrew Body Size	Cast Iron		Aluminum		Cast Iron		Aluminum	
	N•m	ft-lb	N•m	ft-lb	N•m	ft-lb	N•m	ft-lb
1/4 - 20	9	7	8	6	15	11	8	6
1/4 - 28	12	9	9	7	18	13	9	7
5/16 - 18	20	15	16	12	30	22	16	12
5/16 - 24	23	17	19	14	33	24	19	14
3/8 - 16	40	30	25	20	55	40	25	20
3/8 - 24	40	30	35	25	60	45	35	25
7/16 - 14	60	45	45	35	90	65	45	35
7/16 - 20	65	50	55	40	95	70	55	40
1/2 - 13	95	70	75	55	130	95	75	55
1/2 - 20	100	75	80	60	150	110	80	60
9/16 - 12	135	100	110	80	190	140	110	80
9/16 - 18	150	110	115	85	210	155	115	85
5/8 - 11	180	135	150	110	255	190	150	110
5/8 - 18	210	155	160	120	290	215	160	120
3/4 - 10	325	240	255	190	460	340	255	190
3/4 - 16	365	270	285	210	515	380	285	210
7/8 - 9	490	360	380	280	745	550	380	280
7/8 - 14	530	390	420	310	825	610	420	310
1 - 8	720	530	570	420	1100	820	570	420
1 - 14	800	590	650	480	1200	890	650	480

Section W - Warranty

Section Contents

	Page
Gaseous Fueled EnginesWorldwideGenerator DriveCommercial	W-7
Gaseous Fueled EnginesWorldwideGenerator DriveConsumer	W-5
Gaseous Fueled EnginesWorldwideIndustrial (Off Highway)Commercial	W-3
Gaseous Fueled EnginesWorldwideIndustrial (Off Highway)Consumer	W-1

Section W - Warranty

Section W - Warranty

Section W - Warranty

This Page Left Intentionally Blank

Gaseous Fueled Engines Worldwide Industrial (Off Highway) Consumer PRODUCTS COVERED

Cummins Inc. (Cummins) warrants to the purchaser (and any subsequent owner) for personal, family or household use (the "Owner") that the following products or components are free from defects in materials and workmanship appearing within the time and/or mileage indicated.

PRODUCT WARRANTY	DURATION of WARRANTY
Base Engine Warranty: New Cummins Gaseous Off-Highway Engines sold by Cummins and delivered to the first user on or after October 1, 2004.	Two years or 2,000 hours of operation, whichever comes first, from the date of delivery to the first end-user; provided, however, that if 2,000 hours of operation are met within the first year, coverage will last until the end of that year.
Accessories Warranty: Cummins branded accessories, excluding clutches and filters.	The duration of the Base Engine Warranty.
Belts Warranty: Belts supplied by Cummins.	One year or 500 hours of operation, whichever comes first, from the date of delivery to the first end-user.

THERE ARE NO EXPRESS WARRANTIES OTHER THAN THE ABOVE LIMITED WARRANTIES.

IN NO EVENT SHALL ANY IMPLIED WARRANTIES, INCLUDING ANY IMPLIED WARRANTIES OF MERCHANTABILITY OR FITNESS FOR PARTICULAR PURPOSE, EXTEND BEYOND THE DURATION OF THESE WARRANTIES.

Some states do not allow limitations on how long an implied warranty lasts.

PRODUCTS NOT COVERED

The following products are not covered by any of the limited warranties described above:

Any accessories bearing the name or brand of another company, even if supplied by Cummins.

OTHER EXCLUSIONS

These limited warranties do not apply to the following:

1. . Engines used commercially, industrially, for competition.
2. . Normal wear and tear.
3. . Damage caused by accidents, abuse, alteration, modification, misuse, neglect or improper care or maintenance, including, but not limited to, the following: operation without adequate coolants or lubricants; overfueling; overspeeding; lack of maintenance of lubricating, cooling or intake systems; improper storage; and starting, warm-up, run-in or shutdown practices.
4. . Damage or failures caused by repair or replacement using parts not supplied, rebuilt or repaired by Cummins.
5. . Damage caused by operation of the engine outside of the recommended specifications for timing and/or fueling.
6. . Damage or failures caused by incorrect oil or fuel or by the presence of water, dirt or other contaminants in the fuel, oil and/or coolant.
7. . Claims for excessive oil consumption where the Owner cannot provide adequate documentation to show that consumption met or exceeded published standards.
8. . Damage due to the failure to follow all instructions specified in the Cummins Operation and Maintenance Manual. Proof of proper maintenance is the Owner's responsibility. Keep all receipts and be prepared to make them available if questions arise about maintenance.
9. . The cost of normal maintenance or replacement of parts which are not defective. These are the sole responsibility of the Owner.

REMEDIES

Cummins will repair or replace, free of charge, the defective part or product.

Cummins will pay for all labor costs to remove and/or reinstall the Engine or to repair parts, and will also pay for any additional replacement parts needed for the repair (even if such parts are not defective in material or workmanship).

Any repair or replacement must be done by Cummins or a Cummins distributor.

If Cummins replaces maintenance items, including, but not limited to, lubricating oil, antifreeze and filter elements, because they have been damaged by a warranted failure, Cummins will repair or replace these maintenance items

free of charge; if such items are replaced at the Owner's request in the course of repair, and not because they have been damaged by a warranted failure, the cost of such replacement is the sole responsibility of the Owner.

Any part repaired or replaced by Cummins or a Cummins distributor under this Warranty will be covered by the remainder of the applicable warranty.

CUMMINS' ONLY RESPONSIBILITY, AND THE OWNER'S ONLY REMEDY, IS REPAIR OR REPLACEMENT AS DESCRIBED IN THIS WARRANTY.

CUMMINS SHALL NOT BE LIABLE FOR INCIDENTAL, CONSEQUENTIAL OR SPECIAL DAMAGES.

Some states do not allow the exclusion or limitation of incidental or consequential damages, so the above exclusions may not apply to you. This warranty gives you specific legal rights, and you may also have other legal rights which vary from state to state.

HOW TO OBTAIN SERVICE

To obtain warranty service in the United States, the Engine or part believed to be defective, and proof of the date of delivery to the first end-user must be presented to a Cummins distributor. Any charges incurred for service calls, meals, lodging, transportation to/from the Cummins distributor and other similar costs are the responsibility of the Owner. If you have any questions regarding this limited warranty, please visit our website at <http://www.cummins.com>.

Gaseous Fueled Engines Worldwide Industrial (Off Highway) Commercial PRODUCTS COVERED

Cummins Inc. (Cummins) warrants to the purchaser (and any subsequent owner) for industrial and commercial use (the "Owner") that the following products or components are free from defects in materials and workmanship appearing within the time and/or mileage indicated.

PRODUCT WARRANTY	DURATION of WARRANTY
Base Engine Warranty: New Cummins Gaseous Off-Highway Engines sold by Cummins and delivered to the first user on or after October 1, 2004, for industrial and commercial use.	Two years or 2,000 hours of operation, whichever comes first, from the date of delivery to the first end-user; provided, however, that if 2,000 hours of operation are met within the first year, coverage will last until the end of that year.
Accessories Warranty: (1) Cummins Branded Accessories, excluding clutches and filters.	The duration of the Base Engine Warranty.
Belts Warranty: Belts supplied by Cummins.	One year or 500 hours of operation, whichever comes first, from the date of delivery to the first user.

THERE ARE NO EXPRESS WARRANTIES OTHER THAN THE ABOVE WARRANTIES, WHICH ARE IN LIEU OF ANY IMPLIED WARRANTIES, INCLUDING ANY IMPLIED WARRANTIES OF MERCHANTABILITY OR FITNESS FOR PARTICULAR PURPOSE.

PRODUCTS NOT COVERED

The following products are not covered by any of the limited warranties described above:

Any accessories bearing the name or brand of another company, even if supplied by Cummins.

OTHER EXCLUSIONS

These limited warranties do not apply to the following:

- Engines used for personal, family or household purposes, or for competition.
- Normal wear and tear.
- Damage caused by accidents, abuse, alteration, modification, misuse, neglect or improper care or maintenance, including, but not limited to, the following: operation without adequate coolants or lubricants; overfueling; overspending; lack of maintenance of lubricating, cooling or intake systems; improper storage; and starting, warm-up, run-in or shutdown practices.
- Damage or failures caused by repair or replacement using parts not supplied, rebuilt or repaired by Cummins.
- Damage caused by operation of the engine outside of the recommended specifications for timing and/or fueling.
- Damage or failures caused by incorrect oil or fuel or by the presence of water, dirt or other contaminants in the fuel, oil, air and/or coolant.
- Claims for excessive oil consumption where the Owner cannot provide adequate documentation to show that consumption met or exceeded published standards.
- Damage due to the failure to follow all instructions specified in the Cummins Operation and Maintenance Manual. Proof of proper maintenance is the Owner's responsibility. Keep all receipts and be prepared to make them available if questions arise about maintenance.
- The cost of normal maintenance or replacement of parts which are not defective. These are the sole responsibility of the Owner.

REMEDIES

Cummins will repair or replace, free of charge, the defective part or product.

Cummins will pay for all labor costs to remove and/or reinstall the Engine or to repair parts, and will also pay for any additional replacement parts needed for the repair (even if such parts are not defective in material or workmanship).

Any repair or replacement must be done by Cummins or a Cummins distributor.

If Cummins replaces maintenance items, including, but not limited to, lubricating oil, antifreeze and filter elements, because they have been damaged by a warranted failure, Cummins will repair or replace these maintenance items free of charge; if such items are replaced at the Owner's request in the course of repair, and not because they have been damaged by a warranted failure, the cost of such replacement is the sole responsibility of the Owner.

Any part repaired or replaced by Cummins or a Cummins distributor under this Warranty will be covered by the remainder of the applicable warranty.

CUMMINS' ONLY RESPONSIBILITY, AND THE OWNER'S ONLY REMEDY, IS REPAIR OR REPLACEMENT AS DESCRIBED IN THIS WARRANTY.

CUMMINS SHALL NOT BE LIABLE FOR INCIDENTAL, CONSEQUENTIAL OR SPECIAL DAMAGES.

HOW TO OBTAIN SERVICE

To obtain warranty service in the United States, the Engine or part believed to be defective, and proof of the date of delivery to the first end-user must be presented to a Cummins distributor. Any charges incurred for service calls, meals, lodging, transportation to/from the Cummins distributor and other similar costs are the responsibility of the Owner.

The owner must present the engine to the distributor for repair or replacement under this warranty.	The distributor must repair or replace the engine or part under this warranty.
The owner must pay for any charges incurred for service calls, meals, lodging, transportation to/from the Cummins distributor and other similar costs.	The distributor must provide the engine or part under this warranty.

TO OBTAIN WARRANTY SERVICE IN THE UNITED STATES, THE ENGINE OR PART BELIEVED TO BE DEFECTIVE, AND PROOF OF THE DATE OF DELIVERY TO THE FIRST END-USER MUST BE PRESENTED TO A CUMMINS DISTRIBUTOR. ANY CHARGES INCURRED FOR SERVICE CALLS, MEALS, LODGING, TRANSPORTATION TO/FROM THE CUMMINS DISTRIBUTOR AND OTHER SIMILAR COSTS ARE THE RESPONSIBILITY OF THE OWNER.

OWNER'S ONLY RESPONSIBILITY, AND THE OWNER'S ONLY REMEDY, IS REPAIR OR REPLACEMENT AS DESCRIBED IN THIS WARRANTY. CUMMINS SHALL NOT BE LIABLE FOR INCIDENTAL, CONSEQUENTIAL OR SPECIAL DAMAGES.

TO OBTAIN WARRANTY SERVICE IN THE UNITED STATES, THE ENGINE OR PART BELIEVED TO BE DEFECTIVE, AND PROOF OF THE DATE OF DELIVERY TO THE FIRST END-USER MUST BE PRESENTED TO A CUMMINS DISTRIBUTOR. ANY CHARGES INCURRED FOR SERVICE CALLS, MEALS, LODGING, TRANSPORTATION TO/FROM THE CUMMINS DISTRIBUTOR AND OTHER SIMILAR COSTS ARE THE RESPONSIBILITY OF THE OWNER.

OWNER'S ONLY RESPONSIBILITY, AND THE OWNER'S ONLY REMEDY, IS REPAIR OR REPLACEMENT AS DESCRIBED IN THIS WARRANTY. CUMMINS SHALL NOT BE LIABLE FOR INCIDENTAL, CONSEQUENTIAL OR SPECIAL DAMAGES.

TO OBTAIN WARRANTY SERVICE IN THE UNITED STATES, THE ENGINE OR PART BELIEVED TO BE DEFECTIVE, AND PROOF OF THE DATE OF DELIVERY TO THE FIRST END-USER MUST BE PRESENTED TO A CUMMINS DISTRIBUTOR. ANY CHARGES INCURRED FOR SERVICE CALLS, MEALS, LODGING, TRANSPORTATION TO/FROM THE CUMMINS DISTRIBUTOR AND OTHER SIMILAR COSTS ARE THE RESPONSIBILITY OF THE OWNER.

OWNER'S ONLY RESPONSIBILITY, AND THE OWNER'S ONLY REMEDY, IS REPAIR OR REPLACEMENT AS DESCRIBED IN THIS WARRANTY. CUMMINS SHALL NOT BE LIABLE FOR INCIDENTAL, CONSEQUENTIAL OR SPECIAL DAMAGES.

TO OBTAIN WARRANTY SERVICE IN THE UNITED STATES, THE ENGINE OR PART BELIEVED TO BE DEFECTIVE, AND PROOF OF THE DATE OF DELIVERY TO THE FIRST END-USER MUST BE PRESENTED TO A CUMMINS DISTRIBUTOR. ANY CHARGES INCURRED FOR SERVICE CALLS, MEALS, LODGING, TRANSPORTATION TO/FROM THE CUMMINS DISTRIBUTOR AND OTHER SIMILAR COSTS ARE THE RESPONSIBILITY OF THE OWNER.

Gaseous Fueled Engines Worldwide Generator Drive Consumer

PRODUCTS COVERED

Cummins Inc. warrants to the purchaser (and any subsequent owner) for personal, family or household use solely in generator drive applications (the "Owner") that the following products or components are free from defects in materials and workmanship appearing within the time or hours or actual operation indicated:

PRODUCT WARRANTY	DURATION of WARRANTY
Base Engine Warranty: New Cummins engines sold by Cummins and delivered to the first user on or after October 1, 2004. The duration of the warranty depends on the power rating assigned to the engine which can be found stamped on the engine data plate.	
Standby Power Rating	24 months or 400 hours of actual operation, whichever comes first, from the date of delivery to the first end-user.
Unlimited Time Running Prime Power Rating	12 months from the date of delivery to the first end-user
Limited Time Running Prime Power Rating	12 months or 750 hours of actual operation, whichever comes first, from the date of delivery to the first end-user.
Continuous/Base Power Rating	12 months from the date of delivery to the first end-user
Accessories Warranty: Cummins branded accessories, excluding clutches and filters.	The duration of the Base Engine Warranty.
Belts Warranty: Belts supplied by Cummins.	One year or 500 hours of actual operation, whichever comes first, from the date of delivery to the first end-user.

THERE ARE NO EXPRESS WARRANTIES OTHER THAN THE ABOVE LIMITED WARRANTIES.

IN NO EVENT SHALL ANY IMPLIED WARRANTIES, INCLUDING ANY IMPLIED WARRANTIES OF MERCHANTABILITY OR FITNESS FOR PARTICULAR PURPOSE, EXTEND BEYOND THE DURATION OF THESE WRITTEN WARRANTIES.

Some states do not allow limitations on how long an implied warranty lasts.

PRODUCTS NOT COVERED

The following products are not covered by any of the limited warranties described above:

Any accessories bearing the name or brand of another company, even if supplied by Cummins.

OTHER EXCLUSIONS

These limited warranties do not apply to the following:

1. . Engines used commercially, industrially, for competition or in applications other than generator drive applications.
2. . Normal wear and tear.
3. . Damage caused by accidents, abuse, alteration, modification, misuse, neglect or improper care or maintenance, including, but not limited to, the following: operation without adequate coolants or lubricants; overfueling; overspeeding; lack of maintenance of lubricating, cooling or intake systems; improper storage; and starting, warm-up, run-in or shutdown practices.
4. . Damage caused by operation of the engine outside of the recommended specifications for timing and/or fueling.
5. . Damage or failures caused by repair or replacement using parts not supplied, rebuilt or repaired by Cummins.
6. . Damage or failures caused by incorrect oil or fuel or by the presence of water, dirt or other contaminants in the fuel, oil, air and/or coolant.
7. . Claims for excessive oil consumption where the Owner cannot provide adequate documentation to show that consumption met or exceeded published standards.
8. . Damage due to the failure to follow all instructions specified in the Cummins Operation and Maintenance Manual. Proof of proper maintenance is the Owner's responsibility. Keep all receipts and be prepared to make them available if questions arise about maintenance.
9. . The cost of normal maintenance or replacement of parts which are not defective. These are the sole responsibility of the Owner.

10. Any engine on which the hourmeter has been disconnected or damaged by causes other than warranted defects, except to the extent that, after presuming 400 hours of actual operation for each month since delivery to the first end-user, the applicable warranty remains in force.
11. Use of an engine that is inconsistent with its applicable rating as described in the Cummins Operation and Maintenance Manual.
12. Failure to make installations adequately or correctly in accordance with the Cummins Generator Drive Installation Guidelines.

REMEDIES

Cummins will repair or replace, free of charge, the defective part or product during normal business hours.

Cummins will pay for all labor costs to remove and/or reinstall the engine or to repair parts, and will also pay for any additional replacement parts needed for the repair (even if such parts are not defective in material or workmanship).

Any repair or replacement must be done by Cummins or a Cummins distributor. (The Owner is responsible for providing sufficient access to enable the servicing entity to remove the engine from the installation.)

If Cummins replaces maintenance items, including, but not limited to, lubricating oil, antifreeze and filter elements, because they have been damaged by a warranted failure, Cummins will repair or replace these maintenance items free of charge; if such items are replaced at the Owner's request in the course of repair, and not because they have been damaged by a warranted failure, the cost of such replacement is the sole responsibility of the Owner.

Any part repaired or replaced by Cummins or a Cummins distributor under this Warranty will be covered by the remainder of the applicable warranty.

CUMMINS' ONLY RESPONSIBILITY, AND THE OWNER'S ONLY REMEDY, IS REPAIR OR REPLACEMENT AS DESCRIBED IN THIS WARRANTY.

CUMMINS SHALL NOT BE LIABLE FOR INCIDENTAL, CONSEQUENTIAL OR SPECIAL DAMAGES.

Some states do not allow the exclusion or limitation of incidental or consequential damages, so the above exclusions may not apply to you. This warranty gives you specific legal rights, and you may also have other legal rights which vary from state to state.

HOW TO OBTAIN SERVICE

To obtain warranty service, contact a Cummins distributor and provide proof of the date of delivery to the first end-user. If you have any questions regarding this limited warranty, please visit our website at <http://www.cummins.com>.

Gaseous Fueled Engines Worldwide Generator Drive Commercial

PRODUCTS COVERED

Cummins Inc. warrants to the purchaser (and any subsequent owner) for industrial and commercial use solely in generator drive applications (the "Owner") that the following products or components are free from defects in materials and workmanship appearing within the time or hours or actual operation indicated:

PRODUCT WARRANTY	DURATION of WARRANTY
<p>Base Engine Warranty: New Cummins engines sold by Cummins and delivered to the first user on or after October 1, 2004. The duration of the warranty depends on the power rating assigned to the engine which can be found stamped on the engine data plate.</p>	
Standby Power Rating	24 months or 400 hours of actual operation, whichever comes first, from the date of delivery to the first end-user.
Unlimited Time Running Prime Power Rating	12 months from the date of delivery to the first end-user
Limited Time Running Prime Power Rating	12 months or 750 hours of actual operation, whichever comes first, from the date of delivery to the first end-user.
Continuous/Base Power Rating	12 months from the date of delivery to the first end-user
<p>Accessories Warranty: Cummins branded accessories, excluding clutches and filters.</p>	The duration of the Base Engine Warranty.
<p>Belts Warranty: Belts supplied by Cummins.</p>	One year or 500 hours of actual operation, whichever comes first, from the date of delivery to the first end-user.

THERE ARE NO EXPRESS WARRANTIES OTHER THAN THE ABOVE WARRANTIES, WHICH ARE IN LIEU OF ALL IMPLIED WARRANTIES, INCLUDING ANY IMPLIED WARRANTIES OF MERCHANTABILITY OR FITNESS FOR PARTICULAR PURPOSE.

PRODUCTS NOT COVERED

The following products are not covered by any of the limited warranties described above:

Any accessories bearing the name or brand of another company, even if supplied by Cummins.

OTHER EXCLUSIONS

These limited warranties do not apply to the following:

1. Engines used for personal, family or household purposes, for competition or in applications other than generator drive applications.
2. Normal wear and tear.
3. Damage caused by accidents, abuse, alteration, modification, misuse, neglect or improper care or maintenance, including, but not limited to, the following: operation without adequate coolants or lubricants; overfueling; overspeeding; lack of maintenance of lubricating, cooling or intake systems; improper storage; and starting, warm-up, run-in or shutdown practices.
4. Damage caused by operation of the engine outside of the recommended specifications for timing and/or fueling.
5. Damage or failures caused by repair or replacement using parts not supplied, rebuilt or repaired by Cummins.
6. Damage or failures caused by incorrect oil or fuel or by the presence of water, dirt or other contaminants in the fuel, oil, air and/or coolant.
7. Claims for excessive oil consumption where the Owner cannot provide adequate documentation to show that consumption met or exceeded published standards.
8. Damage due to the failure to follow all instructions specified in the Cummins Operation and Maintenance Manual. Proof of proper maintenance is the Owner's responsibility. Keep all receipts and be prepared to make them available if questions arise about maintenance.
9. The cost of normal maintenance or replacement of parts which are not defective. These are the sole responsibility of the Owner.
10. Any engine on which the hourmeter has been disconnected or damaged by causes other than warranted defects, except to the extent that, after presuming 400 hours of actual operation for each month since delivery to the first end-user, the applicable warranty remains in force.

11. Use of an engine that is inconsistent with its applicable rating as described in the Cummins Operation and Maintenance Manual.
12. Failure to make installations adequately or correctly in accordance with the Cummins Generator Drive Installation Guidelines.

REMEDIES

Cummins will repair or replace, free of charge, the defective part or product during normal business hours.

Cummins will pay for all labor costs to remove and/or reinstall the engine or to repair parts, and will also pay for any additional replacement parts needed for the repair (even if such parts are not defective in material or workmanship).

Any repair or replacement must be done by Cummins or a Cummins distributor. (The Owner is responsible for providing sufficient access to enable the servicing entity to remove the engine from the installation.)

If Cummins replaces maintenance items, including, but not limited to, lubricating oil, antifreeze and filter elements, because they have been damaged by a warranted failure, Cummins will repair or replace these maintenance items free of charge; if such items are replaced at the Owner's request in the course of repair, and not because they have been damaged by a warranted failure, the cost of such replacement is the sole responsibility of the Owner.

Any part repaired or replaced by Cummins or a Cummins distributor under this Warranty will be covered by the remainder of the applicable warranty.

CUMMINS' ONLY RESPONSIBILITY, AND THE OWNER'S ONLY REMEDY, IS REPAIR OR REPLACEMENT AS DESCRIBED IN THIS WARRANTY.

CUMMINS SHALL NOT BE LIABLE FOR INCIDENTAL, CONSEQUENTIAL OR SPECIAL DAMAGES.

HOW TO OBTAIN SERVICE

To obtain warranty service, contact a Cummins distributor and provide proof of the date of delivery to the first end-user.

Lubricating Oil Temperature Above Specification.....	TS-26	Fill.....	119-0
About the Manual	i-2	Marine Applications.....	119-0
General Information.....	i-2	Industrial Applications.....	119-0
Acronyms and Abbreviations	i-12	Flush.....	119-0
General Information.....	i-12	Marine Applications.....	119-0
Additional Service Literature	L-1	Industrial Applications.....	119-0
General Information.....	L-1	Cooling System	V-4
Air Cleaner Element, Paper Type	118-0	Specifications.....	V-4
General Information.....	118-0	C8.3G and C Gas Plus.....	V-4
Air Cleaner Restriction	132-0	L Gas Plus.....	V-4
Maintenance Check.....	132-0	Crankcase Breather Tube	3-5
Air Intake System	V-5	Maintenance Check.....	3-5
Specifications.....	V-5	Cummins Customized Parts Catalog	L-3
Air/Fuel Mixer	118-0	General Information.....	L-3
Adjust.....	118-0	Ordering the Customized Parts Catalog.....	L-3
Clean and Inspect for Reuse.....	118-0	Ordering by Telephone.....	L-3
Finishing Steps.....	118-0	Ordering On-Line.....	L-3
General Information.....	118-0	Cummins/Fleetguard® Filter Specifications	V-8
Install.....	118-0	General Information.....	V-8
Preparatory Steps.....	118-0	Daily Maintenance Procedures - Overview	3-1
Remove.....	118-0	Engine Operation Report.....	3-1
Batteries	118-0	General Information.....	3-1
Inspect.....	118-0	Unusual Engine Noise.....	3-1
Battery Cables and Connections	118-0	Distributors - International	S-36
Initial Check.....	118-0	Locations.....	S-36
Capscrew Markings and Torque Values	V-18	Distributors and Branches	S-3
Capscrew Markings and Torque Values - Metric.....	V-18	Australia.....	S-24
Capscrew Markings and Torque Values - U.S. Customary.....	V-18	Canada.....	S-21
General Information.....	V-18	New Zealand.....	S-28
Charge-Air Piping	132-0	United States.....	S-3
Maintenance Check.....	132-0	Division and Regional Offices	S-2
Cold Weather Starting	1-2	Locations.....	S-2
Using Starting Aids.....	1-2	Drive Belt, Cooling Fan	119-0
Component Manufacturers' Addresses	M-1	Inspect for Reuse.....	119-0
Air Compressors.....	M-1	Install.....	119-0
Air Cylinders.....	M-1	Remove.....	119-0
Air Heaters.....	M-1	Drive Belts	3-3
Air Starting Motors.....	M-1	Maintenance Check.....	3-3
Alternators.....	M-1	Poly-Vee Belt.....	3-3
Auxiliary Brakes.....	M-1	Cogged Belt.....	3-3
Belts.....	M-1	Electrical System	V-7
Catalytic Converters.....	M-1	Specifications.....	V-7
Coolant Level Switches.....	M-1	Emergency and Technical Service	S-1
Clutches.....	M-1	General Information.....	S-1
Coolant Heaters.....	M-2	Engine Acceleration or Response Poor.....	TS-6
Drive Plates.....	M-2	Engine Component Torque Values	V-16
Electric Starting Motors.....	M-2	Component List.....	V-16
Electronic Switches.....	M-2	Engine Decelerates Slowly.....	TS-7
Engine Protection Controls.....	M-2	Engine Diagrams	E-2
Fan Clutches.....	M-2	Engine Views.....	E-2
Fans.....	M-2	Engine Difficult to Start or Will Not Start.....	TS-8
Fault Lamps.....	M-2	Engine Identification	E-1
Filters.....	M-2	Cummins Engine Nomenclature.....	E-1
Flexplates.....	M-2	Engine Dataplate.....	E-1
Fuel Coolers.....	M-2	Engine Mounts	118-0
Fuel Pumps.....	M-2	Inspect for Reuse.....	118-0
Fuel Warmers.....	M-2	Engine Noise Excessive.....	TS-9
Gauges.....	M-3	Engine Operating Range	1-6
Governors.....	M-3	General Information.....	1-6
Heat Sleeves.....	M-3	Engine Power Output Low.....	TS-10
Hydraulic and Power Steering Pumps.....	M-3	Governor Oil	118-0
In-Line Connectors.....	M-3	Drain.....	118-0
Oil Heaters.....	M-3	Fill.....	118-0
Prelubrication Systems.....	M-3	Engine Runs Rough at Idle.....	TS-11
Radiators.....	M-3	Engine Runs Rough or Misfires.....	TS-12
Throttle Assemblies.....	M-3	Engine Shutdown	1-6
Torque Converters.....	M-3	General Information.....	1-6
Coolant Level	3-2	Engine Speed Surges at Low or High Idle.....	TS-13
Maintenance Check.....	3-2	Engine Starts But Will Not Keep Running.....	TS-14
Coolant Loss - External.....	TS-3	Engine Steam Cleaning	118-0
Coolant Recommendations and Specifications	V-11	Clean.....	118-0
Coolant Replacement Requirements.....	V-15	Engine Transient Response Poor.....	TS-15
Cooling System Sealing Additives.....	V-13	Engine Vibration Excessive.....	TS-16
Cooling System Soluble Oils.....	V-13	Engine Will Not Crank or Cranks Slowly (Air Starter).....	TS-17
Fully Formulated Coolant/Antifreeze.....	V-11	Engine Will Not Reach Rated Speed (RPM).....	TS-18
General Information.....	V-11	Engine Will Not Shut Off.....	TS-20
Supplemental Coolant Additive (SCA).....	V-13	Exhaust System	V-6
Test Intervals.....	V-14	Specifications.....	V-6
Testing SCA Concentration Level CC-2602 Test Kit.....	V-14	Fan Hub, Belt Driven	119-0
Coolant Temperature Above Normal - Gradual Overheat.....	TS-4	Maintenance Check.....	119-0
Coolant Temperature Below Normal.....	TS-5	Fan, Cooling	3-4
Cooling Fan Belt Tensioner	227-0	Inspect for Reuse.....	3-4
Maintenance Check.....	227-0	Flow Diagram, Compressed Air System	D-13
Cooling System	119-0	Flow Diagram.....	D-13
Drain.....	119-0	Flow Diagram, Cooling System	D-7
Marine Applications.....	119-0	General Information.....	D-7
Industrial Applications.....	119-0	Flow Diagram, Exhaust System	D-12

Index
Page X-2

General Information.....	D-12	Maintenance Schedule	2-2
Flow Diagram, Fuel System	D-2	General Information.....	2-2
General Information.....	D-2	Industrial Applications.....	2-2
Flow Diagram, Lubricating Oil System	D-3	Power Generation.....	2-3
Flow Diagram.....	D-3	Gas Compression.....	2-4
Lubrication for the Overhead.....	D-6	Normal Starting Procedure	1-2
Lubrication for the Power Components.....	D-5	General Information.....	1-2
Lubrication for the Turbocharger.....	D-4	Operating Instructions - Overview	1-1
Fuel Consumption Excessive.....	TS-21	General Information.....	1-1
Fuel Filter, NG	118-0	Operating the Engine	1-4
Finishing Steps.....	118-0	Ambient Temperature.....	1-5
Install.....	118-0	0 to -32°C [32 to -25°F].....	1-5
Preparatory Steps.....	118-0	-32 to -54°C [-25 to -65°F].....	1-5
Remove.....	118-0	Cold Weather.....	1-5
Fuel System	V-2	Normal.....	1-5
Specifications.....	V-2	Winterfronts and Shutters.....	1-4
Gaseous Fueled EnginesWorldwideGenerator DriveCommercial	W-7	Overhead Set	132-0
Gaseous Fueled EnginesWorldwideGenerator DriveConsumer	W-5	Adjust.....	132-0
Gaseous Fueled EnginesWorldwideIndustrial (Off Highway)Commercial	W-3	Finishing Steps.....	132-0
Gaseous Fueled EnginesWorldwideIndustrial (Off Highway)Consumer	W-1	Preparatory Steps.....	132-0
General Cleaning Instructions	i-8	Overhead Set	118-0
Abrasive Pads and Abrasive Paper.....	i-8	Adjust.....	118-0
Definition of Clean.....	i-8	Finishing Steps.....	118-0
Gasket Surfaces.....	i-9	Preparatory Steps.....	118-0
Plastic Bead Cleaning.....	i-10	Problem Solving	S-1
Solvent and Acid Cleaning.....	i-9	General Information.....	S-1
Steam Cleaning.....	i-10	Radiator Hoses	118-0
General Engine	V-1	Maintenance Check.....	118-0
Specifications.....	V-1	Regional Offices - International	S-29
C8.3G and C Gas Plus.....	V-1	Locations.....	S-29
L Gas Plus.....	V-1	Rocker Lever Cover	132-0
General Repair Instructions	i-7	Clean and Inspect for Reuse.....	132-0
General Information.....	i-7	Finishing Steps.....	132-0
Welding on a Vehicle with an Electronic Controlled Fuel System.....	i-7	Install.....	132-0
General Safety Instructions	i-6	Preparatory Steps.....	132-0
Important Safety Notice.....	i-6	Remove.....	132-0
Governor Oil	3-6	Routine Service and Parts	S-1
Maintenance Check.....	3-6	General Information.....	S-1
How to Use the Manual	i-3	Sealants	V-17
General Information.....	i-3	General Information.....	V-17
Ignition Timing	118-0	Service Literature Ordering Location	L-2
Adjust.....	118-0	Contact Information.....	L-2
Electro-Mechanical Type.....	118-0	Spark Plug Wire	118-0
Electronic Type.....	118-0	Clean and Inspect for Reuse.....	118-0
Illustrations	i-5	Install.....	118-0
General Information.....	i-5	Remove.....	118-0
Low-Temperature Aftercooler (LTA) Water Pump	118-0	Spark Plugs (Standard)	227-0
Clean and Inspect for Reuse.....	118-0	Clean and Inspect for Reuse.....	227-0
Finishing Steps.....	118-0	Install.....	227-0
Initial Check.....	118-0	Remove.....	227-0
Install.....	118-0	Starting Motor	A-1
Preparatory Steps.....	118-0	Install.....	A-1
Remove.....	118-0	Preparatory Steps.....	A-1
Lubricating Oil and Filters	132-0	Remove.....	A-1
Drain.....	132-0	Starting Procedure After Extended Shutdown or Oil Change	1-3
Fill.....	132-0	General Information.....	1-3
General Information.....	132-0	Supplemental Coolant Additive (SCA) and Antifreeze Concentration	227-0
Install.....	132-0	Maintenance Check.....	227-0
Remove.....	132-0	Supplemental Coolant Additive (SCA).....	227-0
Lubricating Oil Consumption Excessive.....	TS-22	Antifreeze.....	227-0
Coolant Filter	118-0	Symbols	i-4
Clean.....	118-0	General Information.....	i-4
Install.....	118-0	System Diagrams - Overview	D-1
Remove.....	118-0	General Information.....	D-1
Lubricating Oil Level	3-5	To the Owner and Operator	i-1
Maintenance Check.....	3-5	General Information.....	i-1
Lubricating Oil Pressure High.....	TS-23	Tool Requirements	2-1
Lubricating Oil Pressure Low.....	TS-24	General Information.....	2-1
Lubricating Oil Recommendations and Specifications	V-9	Troubleshooting Procedures and Techniques	TS-1
General Information.....	V-9	General Information.....	TS-1
Lubricating Oil Sludge in the Crankcase Excessive.....	TS-25	Troubleshooting Symptoms Charts	TS-2
Lubricating Oil System	V-3	General Information.....	TS-2
Specifications.....	V-3	Turbocharger	119-0
C8.3G and C Gas Plus.....	V-3	Maintenance Check.....	119-0
L Gas Plus.....	V-3	Vibration Damper, Rubber	119-0
Maintenance Guidelines - Overview	2-1	Inspect.....	119-0
General Information.....	2-1	Vibration Damper, Viscous	119-0
Maintenance Procedures - Overview	119-0	Inspect.....	119-0
General Information.....	119-0	Water Pump	119-0
Maintenance Procedures - Overview	132-0	Maintenance Check.....	119-0
General Information.....	132-0		
Maintenance Procedures - Overview	227-0		
General Information.....	227-0		
Maintenance Procedures - Overview	118-0		
General Information.....	118-0		
Maintenance Record Form	2-5		
Maintenance Data.....	2-5		

[The following text is extremely faint and illegible due to the quality of the scan. It appears to be a multi-paragraph document.]

SECRET

SECRET

[The body of the document contains several paragraphs of text that are extremely faint and illegible due to the quality of the scan. The text appears to be a formal report or memorandum.]

SECRET

CALIFORNIA
Proposition 65 Warning

Natural Gas engine exhaust and some of its constituents are known to the State of California to cause cancer, birth defects, and other reproductive harm.

Cummins Inc.
Box 3005
Columbus, Indiana, U.S.A., 47202

Registered Office
Cummins Engine Company, Ltd.
46-50 Coombe Road
New Malden,
Surrey KT3 4QL
England
Registration 573951 England

Copyright © 2004
Cummins Engine Company, Inc.

Cummins Customer Assistance Center
1-800-DIESELS (1-800-343-7357)
APPLICABLE ONLY IN U.S.A. AND CANADA