

INSTRUCTION BOOK

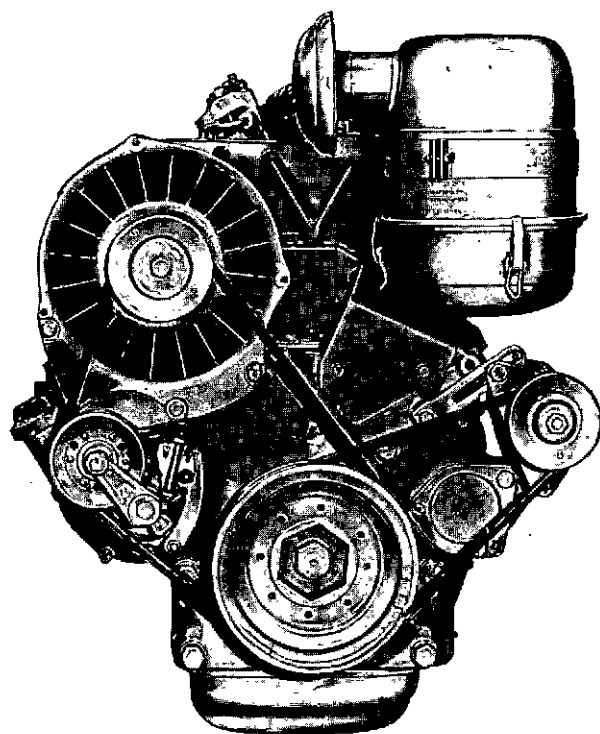

F3-6L912



2971444 UF 0150-99

E

Surely you expect top service from your DEUTZ engine . . .

so please study this booklet very carefully!

Before the engine left our works, it had stood severest tests and trials; it proved that it was in perfect working order in every respect. If you now wish to keep the engine at its high performance level at all times, be sure to give it all the care and attention it needs and deserves. In other words: maintain your engine and you will maintain its efficiency!

However, should trouble arise, after all, do not hesitate to consult your local DEUTZ distributor. We are not only interested in selling our products — we are just as much interested in keeping them going. Because your satisfaction is our reputation.

It will in the first place be in your own interest to contact DEUTZ in cases of trouble, as the shops of our world-wide service organisation are staffed with specially trained mechanics and equipped with specially designed tools and facilities, and since only there can you get

Genuine DEUTZ Spares.

Remember that only parts bearing our name are covered by our full guarantee since only those parts have passed the rigid DEUTZ quality control.

For ordering spare parts, please always refer to the relevant Catalogue.

And now we wish you much success in your work with the DEUTZ engine . . .

Klöckner-Humboldt-Deutz AG



CONTENTS

Cross Section of Engine	2
Lube Oil Circuit	3
Specification Data	4

Engine Operation	5
Fuel	5
Motor Oil	5
Starting	7
Stopping	9
Hints for Winter Operation	9
Air-venting the Fuel System	12

Maintenance Schedule	14
Notes on Maintenance Schedule	18

Workshop Maintenance	32
Trouble Chart	34
Recommended Lube Oils	36

Hints for the Mechanic	38
Bolt Tightening Table	39
Hints on Installing the Engine	40
Engine Preservation	40

Summary Instructions	back cover
-----------------------------	------------

Editing Department	ASJ Köln-Deutz
Issuing Department	MMLV

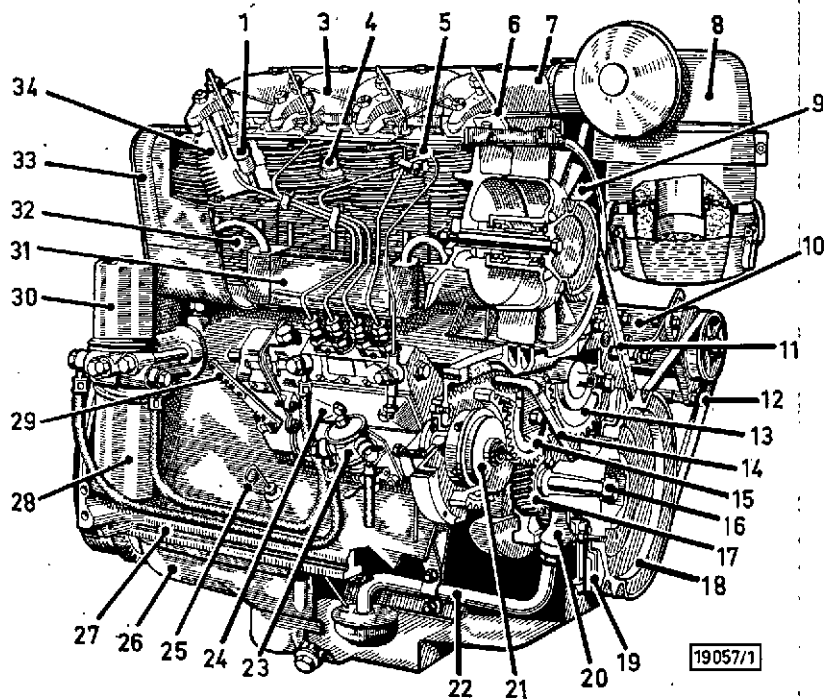

Fig. 1

Cross Section of Engine

- | | |
|--|---|
| 1 Injector with four-hole nozzle | 17 Crankshaft gear |
| 3 Backleakage line | 18 V-belt pulley |
| 4 Cylinder head anti-fatigue bolt (4 bolts securing each cylinder head with cylinder to crankcase) | 19 Vibration damper* |
| 5 Overflow line | 20 Oil pump |
| 6 Injection line to cyl. 4 | 21 Injection pump drive gear with advance/retard unit* |
| 7 Cylinder head cover | 22 Oil suction pipe |
| 8 Oil bath air cleaner (dry-type air cleaner optional) | 23 Fuel lift pump |
| 9 Cooling blower (V-belt-driven) | 24 Bosch in-line injection pump with mech. centrifugal governor |
| 10 Generator (dynamo or alternator) | 25 Oil dipstick |
| 11 Cooling blower V-belt | 26 Oil sump of sheet metal or cast iron |
| 12 Generator V-belt | 27 Crankcase (cast iron) |
| 13 Camshaft gear | 28 Oil filter |
| 14 Oil delivery pipe | 29 Speed control lever |
| 15 Idler gear (driving injection pump and camshaft) | 30 Fuel filter |
| 16 Anti-fatigue bolt (securing V-belt pulley to crankshaft) | 31 Block-type oil cooler* |
| | 32 Finned cylinder of grey cast iron (separately removable) |
| | 33 Removable air cowling |
| | 34 Cylinder head (light alloy) |

* if provided

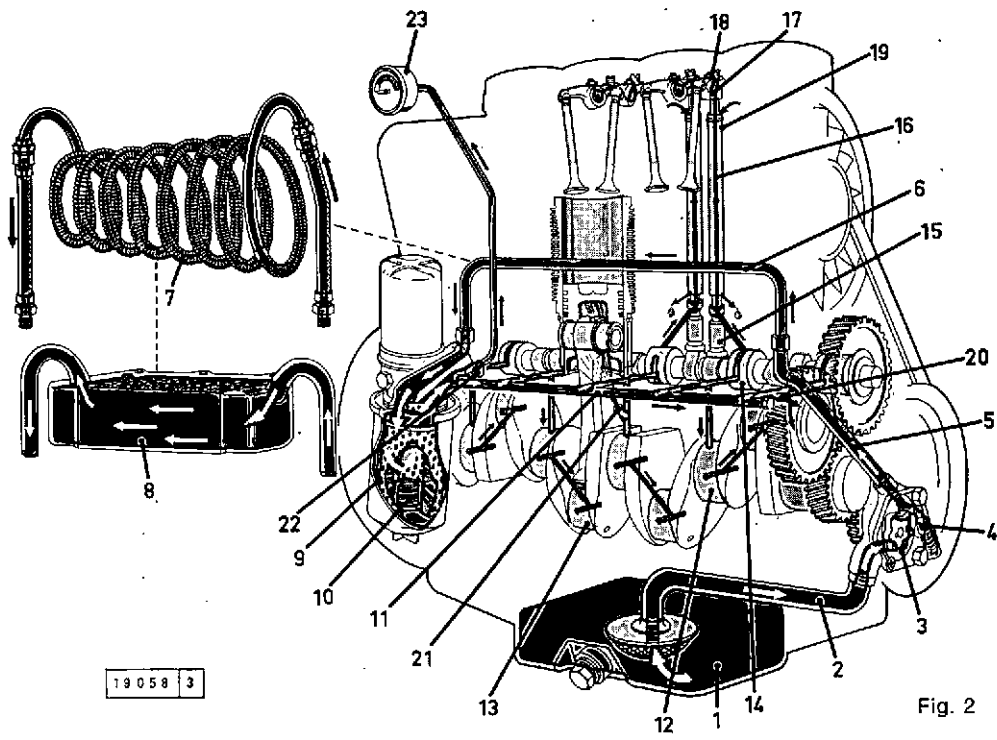

Fig. 2

Lube Oil Circuit

- | | |
|------------------------------|--|
| 1 Oil sump | 14 Camshaft bearing |
| 2 Suction pipe | 15 Tappet (with groove for impulse-lubrication of rocker arms) |
| 3 Lube oil pump | 16 Pushrod (hollow for oil flow to rocker arms) |
| 4 Oil pressure control valve | 17 Rocker arm bearing |
| 5 Delivery pipe | 18 Metering plug (for valve lubrication) |
| 6 Bypass pipe or, at option | 19 Pushrod cover tube (for oil return from cylinder head to crankcase) |
| 7 Cooling coil or, at option | 20 Throttle hole (for lubrication of gears) |
| 8 Block-type cooler | 21 Spray nozzle for piston cooling system |
| 9 Oil filter | 22 Connection for oil pressure gauge |
| 10 Safety valve | 23 Oil pressure gauge |
| 11 Oil gallery | |
| 12 Main Bearing | |
| 13 Big-end bearing | |

Specification Data

Model	F3L 912	F4L 912	F5L 912	F6L 912
Number of cylinders	3	4	5	6
Bore \varnothing mm	100	100	100	100
(in.)	(3 ¹⁵ / ₁₆)	(3 ¹⁵ / ₁₆)	(3 ¹⁵ / ₁₆)	(3 ¹⁵ / ₁₆)
Stroke mm	105/120	105/120	105/120	120
(in.)	4 ²³ / ₃₂	4 ²³ / ₃₂	4 ²³ / ₃₂	4 ²³ / ₃₂
Piston displacement cm ³	2826	3768	4710	5652
(cu.in.)	(172.45)	(229.94)	(287.42)	(344.91)
Direction of rotation (facing flywheel)	counter-clockwise			
Working principle	four-stroke diesel with direct injection			
Weight (less starter and generator) kg	270	300	380	410
approx. (lbs.)	(595.25)	(661.38)	(837.76)	(903.90)
Power output* HP	see rating plate			
Speed* rev/min	see rating plate			
Lubrication system	forced lubrication			
Oil capacity: initial fill approx. ltr.	9**	11**	13.5**	14**
(Imp. gall.)	(1.98)	(2.42)	(2.97)	(3.08)
refill approx. ltr.	8**	9.5**	12**	12**
(Imp. gall.)	(1.76)	(2.09)	(2.64)	(2.64)
Commencement of Injection (In-line injection pump) with advance/retard				F6L B/F6L
unit above 2300 rpm C.A. bef. TDC	24/22°	24/22°	25°	27/25° 24°
with rigid drive up to 1800 rpm C.A. bef. TDC	26°	26°	29°	29°
with rigid drive up to 2300 rpm C.A. bef. TDC	30°	30°	32°	32°
with rigid drive up to 2800 rpm C.A. bef. TDC	32°	32°	35°	35°
with rigid drive up to 3000 rpm C.A. bef. TDC	32°	32°	35°	35°
Commencement of Injection (Distributor injection pump) (With crank angle X° bef. TDC, the plunger stroke being 1 mm)	depends on engine application. See pump flange			
Valve clearance (engine cold)	0.15 mm (0.006 in.)			
Inlet valves open	32° before T.D.C.			
Inlet valves close	60° after B.D.C.			
Exhaust valves open	70° before B.D.C.			
Exhaust valves close	32° after T.D.C.			
} at specified valve clearance				
Piston crown clearance (measured with lead wire)	1.0-1.2 mm (0.040 to 0.047 in.)			
Injection pressure	175+8 atm. (2489.1 p.s.i.)			
Firing order: 3-cylinder	1-2-3			
4-cylinder	1-3-4-2			
5-cylinder	1-2-4-5-3			
6-cylinder	1-5-3-6-2-4			

* Depending on engine application

** Approximate value refers to standard oil sump

Observe dipstick marks!

Note: In view of the constant improvements to our engines, the above specification data as well as other information included in this booklet are subject to change without notice and do not entitle to any claims.

Engine Operation

Starting up a new engine for the first time involves a number of preparatory jobs. Some of these, however, are not confined just to the first starting up. They must also be carried out later on in the course of routine maintenance (please see Maintenance Schedule on page 14).

1. Fuel

Always use a reputable branded grade of fuel (gasoil) with a sulphur content of less than 0.5% and observe strict cleanliness when filling in. At low ambient temperatures use only winter-grade fuel (see hints on page 9). The fuel supply must be replenished promptly to prevent the tank running dry, otherwise the injection pump, fuel filters and injection lines will need air venting (see on page 12). Our engines leave our works without any fuel in the tank, and air venting must therefore be carried out before starting up for the first time.

2. Oil Change and checking Oil level (see on page 18, B 1)

2.1 Oil Quality

During operation of the engine not only part of the oil lubricating the pistons is burnt ("consumed"), but the thermal stress and the combustion residues mixing with the oil also entail a degradation of the oil and in particular of its chemical additives. Therefore, a complete change of the oil has to be carried out at the recommended intervals. As this "degradation" is greatly influenced by the operating conditions as well as by the quality of the fuel and that of the oil ("lubricity"), the oil change intervals differ accordingly. Therefore, the oil grades and oil change periods as specified on page 23 must strictly be observed.

2.2 Oil Viscosity

The viscosity of the oil is more or less greatly influenced by the ambient temperature. As a too viscous oil causes starting difficulties, the temperature prevailing at the time of starting and not the peak temperature during the day should govern the choice of the viscosity grade.

To suit **ambient temperatures**, the oils should have the following viscosity grades:

Above +20° (68° F) SAE 30
From +20° C to -10° C (68° F to 14° F) SAE 20 W/20

For **industrial engines** in continuous full-load operation, the viscosity grade should be the following:

Above +10° (50° F) SAE 30

SAE 20 W/20 may be used all the year round, provided the temperatures are not extremely high in summer or continually low in winter.

If you intend to use multi-grade oils, they should satisfy the requirements of high-quality HD-B motor oils* in conformity with MIL-L-46152 specification. The multi-grade oils, too are subject to the oil change periods recommended on page 23.

For starting at low ambient temperatures, please see our special notes on page 10.

Oil capacities are given under "Specification Data" on page 4.

3. Injection Pump and Governor (Fig. 20, page 22)

These units also contain a certain amount of lubricating oil, the level of which can be checked by means of the check plug. They must be filled with the same grade of oil as used in the engine itself.

4. Oil Bath Air Cleaner

The air cleaner must be filled with oil before starting up (see B 2, page 18). To do this, fill in the same grade of motor oil as that used for the engine. Be sure not to fill dust trap 7 of precleaner 6 with oil as it is exclusively meant for collecting dust.

5. Tachometer

When a mechanical tachometer with hourmeter is fitted, the operating hours can accurately be determined by multiplying the recorded hours by the factor given in the table below.

Engine rpm	Factor	Engine rpm	Factor
1500	1	2300	0.65
1800	0.85	2500	0.6
2000	0.75	2650	0.57
2150	0.7	2800	0.537

Example:

Indicated Operating Hours		Factor at 2300 rpm		Actual Operating Hours
10	x	0.65	=	6.5

* See B 6, page 23.

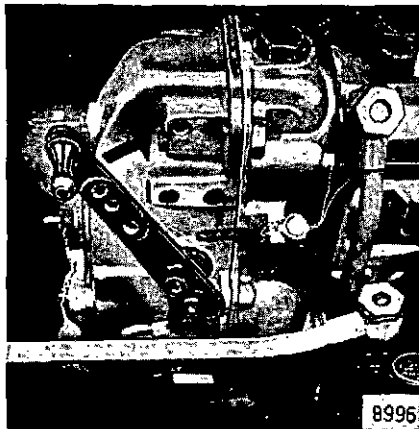

Fig. 3

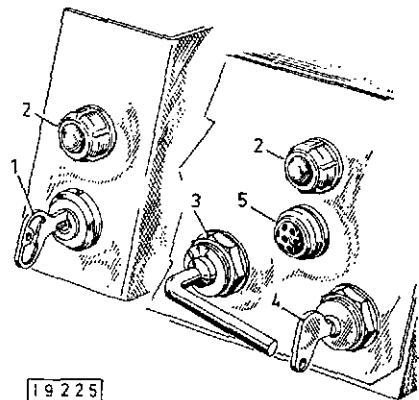

Fig. 4

Starting and Stopping of Engines with Bosch In-line Injection Pump

Starting

1. Disengage the clutch.
2. Move speed control (Fig. 3) to about quarter speed by hand or foot (arrowed direction).
3. Insert starter key 1 (Fig. 4), turn clockwise to first detent and check that charging pilot lamp 2 lights up. Push key in deeper and turn farther clockwise against spring pressure; release key as engine starts firing.

Design with heater plug/starter switch 3: Insert switch box key 4 as far as it will go and turn key of switch 3 via position 1 to position 2; release key as engine starts firing.

For starting under winter conditions please refer to the instructions on page 10, Section 3.

Do not leave the starter motor running uninterruptedly for more than 10 seconds. Also, battery life will be prolonged if an interval of about one minute is allowed between successive starting attempts.

4. Cut the speed back as soon as the engine is firing smoothly. The charging pilot lamp should by now have gone out. A few minutes' running at moderate load and varying speed will bring the engine up to its normal working temperature. On engines driving electric generating sets warming up should be done at preset rated speed.

When an oil pressure gauge with red/green dial is fitted, the pointer must stand at green.

When pointing to the red sector*), the engine must be shut down immediately and the cause be traced on the lines of the trouble chart. This also applies where a green warning lamp lights up.

In the window of the temperature indicator a green sector is displayed when the engine is at normal working temperature. **The appearance of a red sector with "Stop" in this window means that the engine is overheated and must be shut down immediately.** In this case the cause of the overheating must likewise be traced on the lines indicated in the trouble chart (see page 32, Section E).

* Temporary pointing to red is admissible at low idling speed, provided the pointer returns to the green sector as speed is increased.

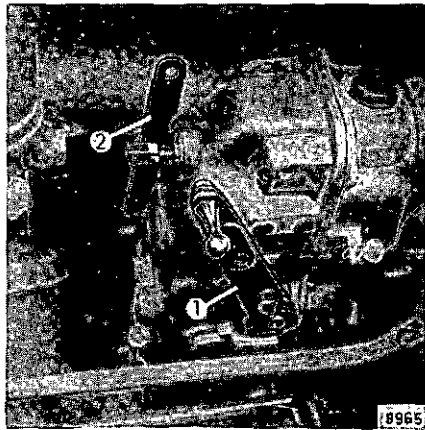

Fig. 5

Stopping

Do not shut the engine down suddenly from full-load running, but let it idle for some time to allow for temperature balance.

1. Set speed control lever 1 (Fig. 5) to low idling.
2. Operate stopping lever 2 on the injection pump until the engine comes to a stop, whereafter the charging pilot lamp 2 (Fig. 4) will light up again.
3. Turn starter key 1 anti-clockwise to detent and pull out or, in the case of design with heater plug/starter switch, pull out switch box key 4; this will cause the charging pilot lamp 2 to go out.

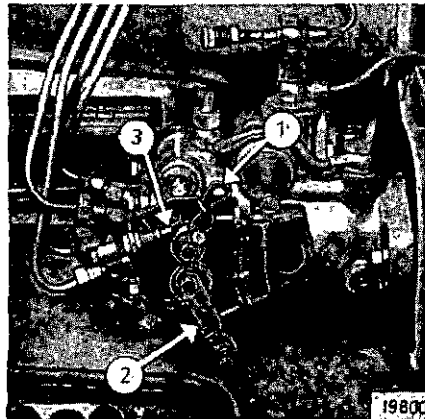

Fig. 6

Starting and Stopping of Engine with Bosch Distributor Injection Pump

Starting

1. Disengage the clutch.
2. With speed control lever 2 in idling position, pull start/stop lever 1 (Fig. 6) to first detent (2/3 and hold).
3. Insert starter key 1 (Fig. 4), turn clockwise to first detent and check that charging pilot lamp 2 lights up. Push key in deeper and turn farther clockwise against spring pressure; release key as engine starts firing.

Design with heater plug/starter switch 3: Insert switch box key 4 as far as it will go and turn switch 3 via position 1 to position 2; release key as engine starts firing.

For starting under winter conditions please refer to instructions on page 10, Section 3.

Do not leave the starter motor running for more than 10 consecutive seconds. Also, battery life will be prolonged if an interval of about one minute is allowed between successive starting attempts.

4. Hold start/stop lever until engine fires smoothly, in idling position, but **do not yet actuate speed control lever.**
5. Release start/stop lever and **thereupon** (not at the same time) move speed control lever to full-throttle position (engine will speed up; end of starting operation).

Important:

With the start/stop lever pulled, the speed control lever must be in idling position, otherwise the injection pump will be in "stop" position so that starting is impossible. If the speed control lever is moved too early, i. e. with the engine not yet firing smoothly, the engine will stall.

Stopping

Do not shut engine down suddenly from full-load running, but let it idle for some time to allow for temperature balancing.

Pull start/stop lever vigorously beyond spring detent 3 to fixed stop until engine is stationary. When pulling start/stop lever slowly, there will again be a brisk speeding up of the engine before it comes to rest. This phenomenon is without importance; it can be moderated by a vigorous pull at the start/stop lever. Check that charging pilot lamp 2 (Fig. 4) lights up again.

Turn starter key 1 anti-clockwise to detent and pull out or, in the case of design with heater plug/starter switch, pull out switch box key 4; this will cause the charging pilot lamp 2 to get out.

Hints for Winter Operation

1. Use winter grade motor oil

At low ambient temperatures, the motor oil is subjected to particularly adverse operating conditions. It is therefore necessary to use a high-grade HD oil of the following viscosity classes:

- from +20° C to -10° C (68° F to 14° F) SAE 20 W/20
- Below -10° C (14° F) SAE 10 W

The viscosity class should be selected according to the temperature prevailing at the time of starting, not to the peak temperature of the day.

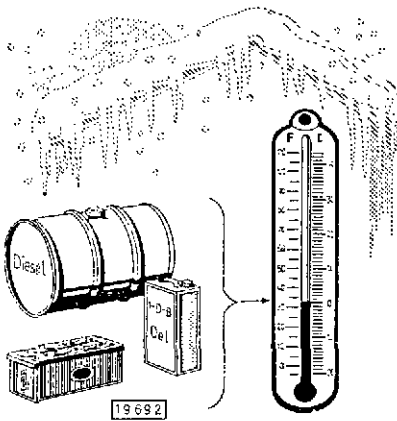

Fig. 7

2. Use winter grade diesel fuel because with ordinary fuel, clouding may occur at low temperatures and clog the fuel filter. At excessively low temperatures, winter grade fuel will cloud, too. Therefore, if only summer grade fuel is available, or if winter grade fuel is used at very low temperatures, we recommend the following admixtures of kerosine, tractor fuel, or standard gasoline, whereby the admixture of the latter is to be considered as a substitute only which can be used for not more than one tank filling:

Ambient Temperature limit	Summer diesel fuel %	Admixture %	Winter diesel fuel %	Admixture %
-10° C (+14° F)	90	10	100	—
-14° C (+ 7° F)	70	30	100	—
-20° C (- 4° F)	50	50	80	20
-30° C (-22° F)	—	—	50	50

Here is a simple method for testing the suitability of diesel fuel: pour some fuel into a small bottle and expose to the cold; clouding would mean that the fuel can be used only at higher temperatures.

3. Starting

3.1 Without Starting Aid (limit temperatures -12° C [10.4° F])*

Provided engine and battery are properly serviced, the direct injection principle enables the engine to start with no need for any starting aid.

3.2 With Preheating Tube (limit temperature -15° C [5° F] — for F3L 912 only —)*

Situated at the inlet of the air intake manifold, the preheating tube uses an electric coil to preheat the combustion air. This preheater not only lowers the starting limit temperature by 3° C but saves the battery and facilitates starting at temperatures where a starting aid will normally not be required.

3.3 With Flame-type Heater Plug (limit temperature -15° C [5° F])*

Likewise situated at the inlet of the air intake manifold, this preheater is a plug that heats up the combustion air by burning a small supply of fuel from the injection pump as metered by a solenoid valve. It likewise lowers the starting limit temperature by 3° C and will prove useful at temperatures normally not requiring a starting aid or on engines that are in a bad shape. This preheater can also be used for afterburning for the purpose of preventing starting smoke.

3.4 With Start Pilot (limit temperature -18° C [0.4° F])*

The start pilot is used to spray starting fuel of high ignitability into the intake manifold during the starting attempt. (See instruction booklet for model Viso 2 or for model Viso F 27).

3.5 With preheating Device

In the case of temperatures below the starting limit temperature, it is possible to start an engine with start pilot only when the engine has been preheated with a preheating device. Parts for connecting preheating devices, however, are only provided on engines intended for operation in extremely cold regions.

* The above start limit temperatures refer to Bosch in-line injection pumps. Where a Bosch distributor-type pump is fitted, the limit temperatures will be higher by 2° C.

3.6 Condition of Battery

The starting limit temperatures mentioned under 3.1–3.4 require satisfactory battery condition and battery temperatures equal to the limit temperatures.

Lowering the limit temperatures by further 4 or 5° C (39.2 or 41° F) is possible by raising the battery temperature to about +20° (68° F). This is done by removing the battery with the engine stopped and storing it in a warm room.

When installing the battery, ensure satisfactory terminal contact by keeping contact surfaces clean and bright. To avoid distortion of terminal cones, be sure to tighten screws only moderately.

3.7 Starting Operation

3.7.1 With Preheating Tube or Flame-type Heater Plug

1. Disengage driven equipment. 2. Place speed control lever at quarter speed; in the case of engines with distributor injection pump, with speed control lever in idling position, pull start/stop lever to first indent (2/3) and hold. 3. Insert switch box key 4 (Fig. 4) as far as it will go and check that battery charge pilot light 2 (Fig. 4) goes on. Turn key of heater plug/starter switch 3 (Fig. 4) to preheating position I and keep here for about 1 minute. Where a flame-type heater plug is provided, check that heater plug indicator 5 (Fig. 4) lights up brightly.

Turn key of heater plug/starter switch 3 to starting position II. Once the engine fires smoothly, release key, which will then return to neutral position. Should the engine not fire smoothly, afterheat in position I. Continue starting attempt for not more than 15 seconds if no firing occurs. When starting attempt is assisted by some firing, the attempt may be sustained for 20–25 seconds. Intervals between starting attempts should be 2 minutes or so, enabling the battery to recover. The next starting attempt has to begin again in preheating position (one minute).

3.7.2 With Start Pilot

Assist starting attempt by operating start pilot until engine runs smoothly. (See instruction booklet for model Viso 2 and for model Viso F 27.) For checking the preheating system see section B 16, page 28.

4. **Drain off the thick sludge from the fuel tank once a week.** Do this by taking out the sludge drain plug. The filter screen 4 (Fig. 18, page 21) in the pre-cleaner of the fuel lift pump should also be cleaned weekly.
5. **The grade of oil in the air cleaner** should suit the ambient temperature just like the engine oil.
6. **The flywheel ring gear** should be lubricated at temperatures below -20° C (-4° F) with low temperature grease, e. g. Bosch FT 1 V31, from time to time through the pinion hole (if necessary remove starter); this will ensure full engagement of the pinion.

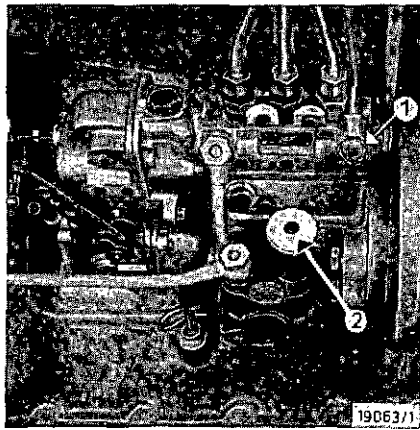

Fig. 8

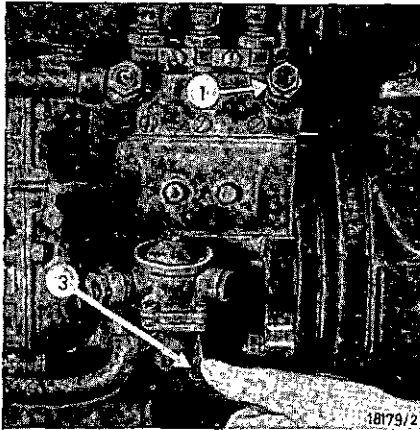

Fig. 9

Air-venting the Fuel System

Make sure that the tank is **never** run dry. The presence of air at any point in the fuel system — whether in the fuel filter or fuel piping — means that there is no fuel at that point. The air which has made its way into the fuel system prevents the proper flow of fuel to the injection pump so that the engine will either start with difficulty or not at all. Therefore, after the fuel filter has been renewed and following any work involving disconnection of fuel piping, it is essential to air-vent the fuel system.

In-line Injection Pump

Where a Bosch lift pump (Fig. 8) is provided, release hex. bolt 1 of spill valve (Fig. 8) on injection pump by two or three turns. Give the knurled knob 2 of the hand priming pump a few turns counter-clockwise to release it from the locked position and then pump it up and down until fuel free from air bubbles emerges at the released hex. bolt 1. Retighten hex. bolt 1. When finished with the hand priming pump the knob must be firmly screwed back to its locked position without fail.

Where a Pierburg lift pump (Fig. 9) is provided, operate priming lever 3 by thumb pressure downwards until fuel free of bubbles emerges at the spill valve after removing hex. bolt 1; thereafter refit hex. bolt.

When operated by hand, the lift pump will only work if the camshaft of the injection pump is in such position that the diaphragm of the lift pump is not lifted.

When operating the prime lever, the distinctly perceivable "pressure point", i. e. the commencement of the lifting movement of the diaphragm has to occur in the first quarter of its total travel, if not turn engine over a little by hand.

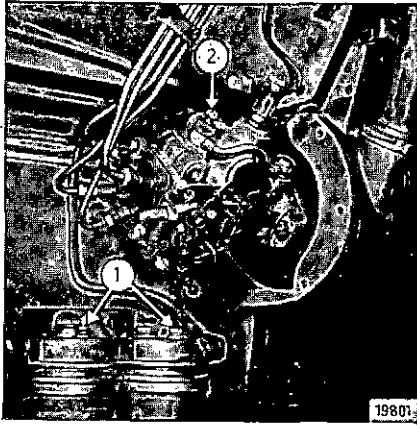

Fig. 10

Distributor-type Injection Pump

Loosen vent plug 1 (Fig. 10) on two-stage fuel filter until fuel comes out free from air bubbles. Loosen vent plug 2 on injection pump and operate starter motor until fuel comes out here too free from bubbles.

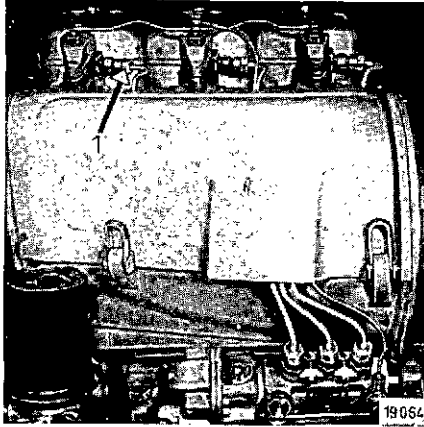







Fig. 11

If the fuel injection lines have been taken down, these also must be air-vented. Do this by operating the starting motor until fuel free from air bubbles emerges at union nut 1 (Fig. 11) at the respective end of the injection line, after slackening the nut through 2 or 3 turns. While doing so, the speed control must be on full speed.

MAINTENANCE SCHEDULE FL 912/3-6 Cyl.

Perform at following intervals	B = Routine servicing W = Workshop maintenance	Page
Every  hours	B 1 Check engine-oil level	18
	B 2 Check air cleaner and clean (every 10-60 hours according to dust conditions)	18
	B 3 Check water separator	21
Every  hours	B 4 Clean strainer of fuel lift pump	21
	B 5 Check oil level in injection pump and governor	22
	B 6 Change engine oil	23
	B 7 Clean cooling fins and, if provided, hydraulic oil cooler (if necessary, at more frequent intervals)	24
	B 8 Check warning device for correct function	25
	B 9 Check electrolyte in battery	25
	B 6 Change engine oil	23
	B 10 Renew oil filter cartridge	26
Every  hours	B 11 Check valve clearance, initially after 20 hours	27
	B 12 Check V-belt tension	28
	B 13 Renew 1st stage of two-stage fuel filter (on version with distributor-type pump)	30
Every  hours	B 14 Renew 2nd stage of two-stage fuel filter (on version with distributor-type pump)	30
	B 15 Renew single fuel filter cartridge (on version with in-line pump)	31
Before the cold season begins	B 16 Test heating tube or flame-type heater plug	31
Every 600 hours	W 1 Check temperature indicator	32
	W 2 Check injectors	32
	W 3 Check fixation of intake and exhaust manifolds	32
	W 4 Check dynamo	33
Every  hours	W 5 Check alternator	33
	W 6 Check starter motor	33
Every 3000 hours	W 7 Check injection pump	34

The maintenance jobs duly completed can be recorded and certified in the schedule below.

Carry out

after every 120 hours maintenance jobs B 4 to B 9

after every 240 hours maintenance jobs B 4 to B 13

Completed Maintenance Jobs					
after every 120 and 240 running hours					
Hours	Date	Signature	Hours	Date	Signature
* 20					
*60/80					
120			240		
360			480		
600			720		
840			960		
1 080			1 200		
1 320			1 440		
1 560			1 680		
1 800			1 920		
2 040			2 160		
2 280			2 400		
2 520			2 640		
2 760			2 880		
3 000			3 120		
3 240			3 360		
3 480			3 600		
3 720			3 840		
3 960			4 080		
4 200			4 320		
4 440			4 560		
4 680			4 800		
4 920			5 040		
5 160			5 280		
5 400			5 520		
5 640			5 760		
5 880			6 000		

* See instructions at bottom of page 17.

The maintenance jobs duly completed can be recorded and certified in the schedule below.

Carry out

after every 120 hours maintenance jobs B 4 to B 9

after every 240 hours maintenance jobs B 4 to B 13

Completed Maintenance Jobs					
after every		120	and	240	running hours
Hours	Date	Signature	Hours	Date	Signature
6 120			6 240		
6 360			6 480		
6 600			6 720		
6 840			6 960		
7 080			7 200		
7 320			7 440		
7 560			7 680		
7 800			7 920		
8 040			8 160		
8 280			8 400		
8 520			8 640		
8 760			8 880		
9 000			9 120		
9 240			9 360		
9 480			9 600		
9 720			9 840		
9 960			10 080		
10 200			10 320		
10 440			10 560		
10 680			10 800		
10 920			11 040		
11 160			11 280		
11 400			11 520		
11 640			11 760		
11 880			12 000		

The maintenance jobs duly completed can be recorded and certified in the schedule below.

Carry out

after every 600 hours maintenance jobs W 1 to W 4

after every 1200 hours maintenance jobs W 1 to W 6 and B 14, B 15

after every 3000 hours check in addition injection pump W 7

Completed Maintenance Jobs					
after every		600		3000	running hours
Hours	Date	Signature		Hours	Date
600				1 200	
1 800				2 400	
3 000				3 600	
4 200				4 800	
5 400				6 000	
6 600				7 200	
7 800				8 400	
9 000				9 600	
10 200				10 800	
11 400				12 000	

Ever-ready Availability

and a long working life will be obtained from the engine if it is given proper maintenance at the recommended intervals. During this work always use the specified lubricants and detergents. The 16 maintenance tasks (B 1) to (B 16) affecting the relatively few lubricating and maintenance points on these engines are not only clearly set out in the Maintenance Schedule but are also explained in detail on the following pages. Please read these pages carefully, too.

Important: Oil changes for New or Overhauled Engines

Routine Change every	1st change after	2nd change after a further	3rd change after a further	Further changes every
100-120 hours	20 hours	40 hours*	-	100-120 hours
200-240 hours	20 hours	60 hours*	120 hours*	200-240 hours

* Renew lube oil filter cartridge at the same time.

When switching over to higher-grade oil, it is advisable to perform the first oil change in any case already at the end of 20 running hours. At the same time, the filter should be cleaned or replaced as required.

Note: When performing the second oil change, be sure to retighten any new V-belts. Retighten fastening bolts of intake and exhaust manifolds at cylinder heads as well as bolts of oil sump and engine mounting. See that the self-adhesive Maintenance Schedule supplied loose with each engine is adhered at a conspicuous point.

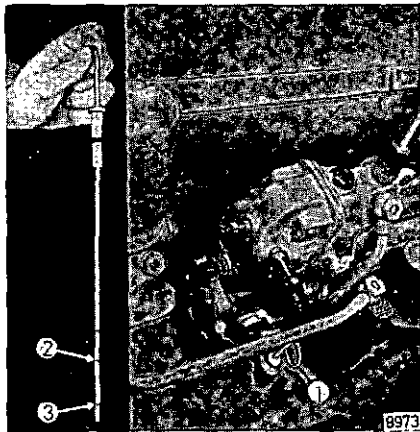

Fig. 12

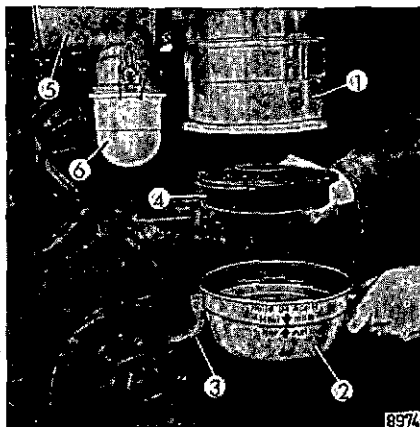

Fig. 13

Notes on Maintenance Schedule

1 running hour roughly corresponds to the following km-performance:

- (a) long-distance vehicles = 50 km
- (b) short-distance vehicles = 25 km

B 1 Checking Engine Oil Level

Normally, new engines have a higher oil consumption. During the running-in period (about 200 running hours) it is therefore essential to check the oil level twice a day. After the running-in period, one check per day is sufficient. This check should be made with the engine in horizontal position. Pull out dipstick 1 (Fig. 12), wipe it with a nonfraying rag, push it in as far as it will go and then withdraw again. The coating of oil left on the dipstick should extend to the upper mark 2. If the level only reaches to the lower mark 3, the oil should be topped up without delay. Failure to attend to this may result in serious damage to the engine (pistons and bearing seizure).

B 2 Checking and Cleaning Air Cleaners

Dust in the combustion air can cause premature wear of the engine. Maintenance of the air cleaners is therefore essential to ensure long life. It is also necessary to check the connecting points of the intake manifold regularly.

Oil Bath Air Cleaner

every 10 to 60 running hours according to dust conditions. This check should only be made after the engine has been stopped for at least one hour that the oil has had time to drip down from cleaner 1 (Fig. 13) into bowl 2. The first step is to release the snap clips 3 so that bowl 2 can be removed. Element 4 of the air cleaner is easily removable by sidewise tapping with the hand or by inserting a screwdriver. Pour out the

dirty oil and clean the dismantled component with diesel fuel. When all the fuel used for cleaning has drained out of element 4 the bowl should be filled up to the mark (arrowheads) with fresh motor oil and the unit then reassembled with element 4 in position.

In the case of moderate dust conditions, the oil bath air cleaner must be taken apart once a year and the fixed upper metal wool be cleansed by repeated immersion in diesel fuel. In case of extreme dust conditions, this procedure has to be carried out twice a year.

Make sure that the rubber washer sealing the air cleaner element is not damaged!

When in very dusty conditions a cyclone-type pre-cleaner 5 is fitted, empty the associated dust trap 6 when it is half full. This dust trap must under no circumstances be filled with oil as it is exclusively meant for collecting dust. Always remember that only a clean air cleaner will give clean combustion air, which is so vital for high engine performance and low wear.

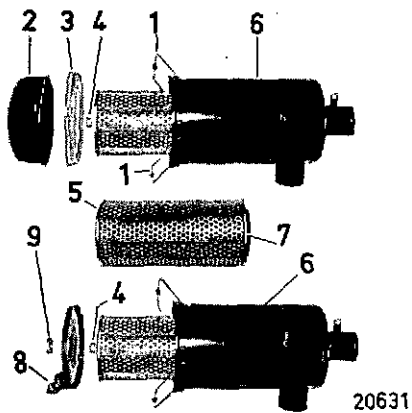

Fig. 14



Fig. 15

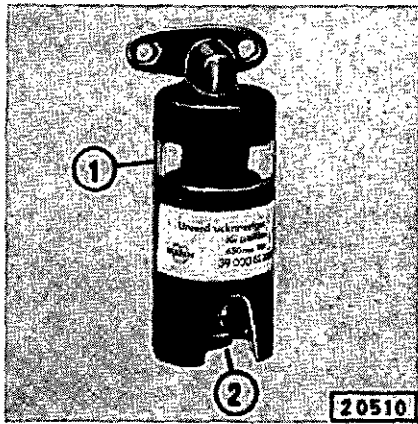

Fig. 16

Dry-type Air Cleaner

The life of the expendable paper cartridges in dry-type air cleaners depends on dust collector 2 (Fig. 14) being emptied in good time. Failing this, the cartridge will clog up fast. **Be sure, therefore, to empty the collector not later than when filled half.** Where the air is very dust-laden, this may require daily servicing.

If a special dust ejector 8 is provided, it is only necessary to clear the discharge slot from time to time.

1. Emptying the Dust Collector

Stop engine.

Release clips 1 (Fig. 14) and remove dust collector 2 along with cover 3. Take down cover and empty collector. Refit assembly, seeing to it that recess on cover mates with lug on collector (see arrows in Fig. 15). When cleaner is installed in horizontal position, check that the "Top" mark is up.

2. Servicing the Cartridge

Where a vacuum-type contamination indicator (Fig. 16) is fitted and keeps displaying the red warning signal 1 when the engine is stopped, or where a yellow warning light goes on with the engine running, the cartridge is due for servicing. (Also indicated by smoking exhaust and decreasing engine output.) It is not advisable to service the cartridge more frequently as this may affect seal 7 (Fig. 14) between cartridge 5 and housing 6.

Proceed by taking down dust collector 2 (Fig. 14) as under 1. (Where a dust ejector 8 is provided, unscrew wing nut 9 and remove cover.) Next unscrew hex. nut 4, take out cartridge and replace or clean as below. After 4 or 5 times cleaning, or where the cartridge is contaminated by soot, replacement is indispensable.

It is urgently recommended to use genuine cartridges of the air cleaner manufacturer only as outside source products are mostly unsuitable and liable to endanger the engine.

Cleaning by dry means:

Tap cartridge 5 with its end gently several times, e. g. against the palm of your hand, to shake off the dust. Alternatively apply air blast of max. 5 atm diagonally inside and out (**do not blow out housing 6**).

Washing the cartridge:

Wash the cartridge by shuttling in lukewarm water containing a commercial-grade mild detergent. Rinse thoroughly in clean water, shake off water and let dry well. In no event use benzine or hot liquids.

3. Checking:

Prior to reassembly, introduce a lighted bulb into filter cartridge 5 to see whether it suffered damage (damaged cartridges must definitely be renewed). Also make sure that gasket 7 is not defective. If a contamination indicator with visual signal is fitted (Fig. 16), push button 2; this causes the red signal to disappear from the window.

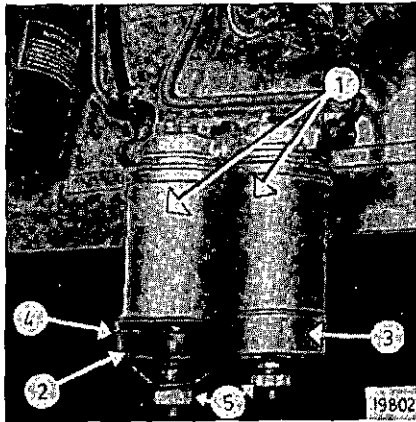

Fig. 17

B 3 Checking Water Separator on Two-stage Fuel Filter

every 10 to 60 running hours according to water content in fuel.

Engines fitted with distributor-type injection pump use a two-stage fuel filter 1 (Fig. 17) with water separator. The water collects in bowls 2 and 3. In the transparent bowl 2; the water is distinguished from the fuel above by its brighter shade. Make sure that water level will not exceed the lower rim of bead 4. To drain water, loosen knurled screw 5 through one or two turns. Next drain water from bowl 3 also.

Note: Be sure not to tighten knurled screw 5 with brute force.

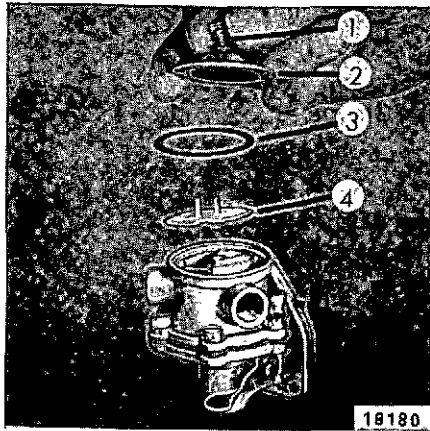

Fig. 18

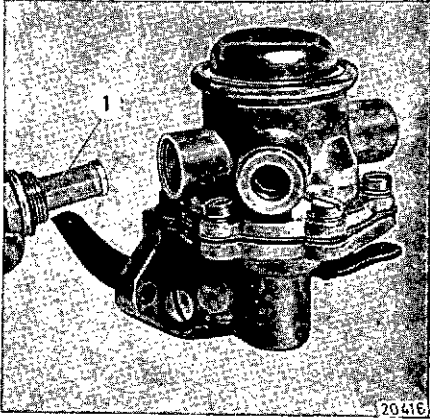

Fig. 19

B 4 Cleaning Strainer of Fuel Lift Pump

Pierburg lift pump in case of **in-line injection pump**.

Every 120 running hours remove consecutively screw 1, cover 2, gasket 3 and strainer 4 (Fig. 18). Clean strainer in fuel. When reassembling, ensure perfect tightness.

Pierburg lift pump in case of **distributor-type injection pump every 120 running hours**. Remove filter 1 (Fig. 19) and clean in fuel. When reassembling ensure perfect tightness.

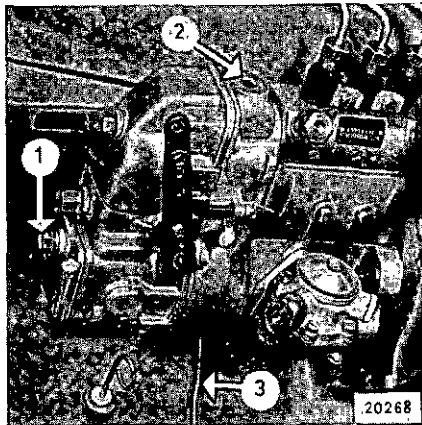

Fig. 20

B 5 Checking Oil Level in Injection Pump and Governor

every 120 running hours. Slacken the oil level check plug 1 (Fig. 20) through 3 turns to drain any surplus oil/fuel mixture. If necessary remove screw plug 2 and fill in fresh oil until it spills at check plug 1. At the end of 3,000 hours or 100,000 km (62,000 miles) renew the entire oil filling.

Approximate oil quantities are as follows:

Standard design

for F3L 912 370 cm³
 for F4L 912 390 cm³
 for F5L 912 480 cm³
 for F6L 912 480 cm³

If the engine is operated more than 1 hour at the following inclinations, the oil level in the injection pump has to be raised.

Inclinations

toward blower or flywheel side: 15° or more
 towards injection pump or exhaust side: 20° or more

Approximate oil quantities:

for F3L 912 850 cm³
 for F4L 912 1050 cm³
 for F5L 912 1250 cm³
 for F6L 912 1250 cm³

The oil level in this case being higher than the check plug, the plug must never be removed.

Use a piece of wire to make sure that spill pipe 3 is not clogged.

Be sure to carry out an oil change routine according to the table below. (Regarding the suitable viscosity class see 2.2 on page 5).

Operating conditions	Sulphur content of fuel (% by wt.)	Oil change intervals (hours according to specified oil grades)		
		HD-S 1	HD-B	HD-C
Normal	up to 0.5	100-120	200-240	200-240
Normal	over 0.5		100-120	200-240
Heavy*	up to 0.5			
Heavy*	over 0.5			100-120

In the case of engines on temporary duty only, e. g. standby power generation, carry out oil changes not later than at the end of six months.

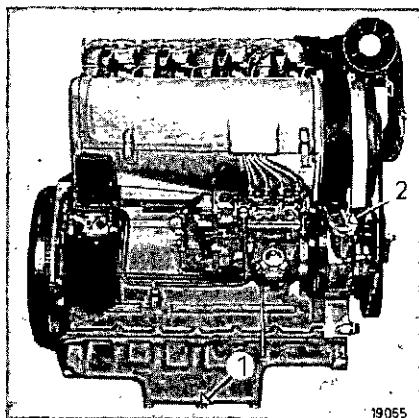

Fig. 21

Regarding initial oil change for new or overhauled engines, please see page 17.

Note: Carry out oil change when the engine is hot, since the old oil will run out more easily in this condition.

Proceed by unscrewing drain plug 1 (Fig. 21). When all old oil has run off, refit drain plug and fill in fresh oil through filler neck 2 up to top dipstick mark (Fig. 12), but not higher. Following a short trial run check oil level again.

Oil capacity at Refill (approx.)

3 cyl.: 8 ltr. (1.76 Imp. gall.)
 4 cyl.: 9.5 ltr. (2.09 Imp. gall.)
 5 cyl.: 12 ltr. (2.64 Imp. gall.)
 6 cyl.: 12 ltr. (2.64 Imp. gall.)

These approximate values always refer to standard oil sumps. **Observe dipstick marks!**

Oil Grades:

- ** HD-S 1 oils are motor oils conforming to MIL-L-2104 A, Supplement 1 or DEF 2101 D.
- ** HD-B oils are high-blended motor oils corresponding to specification MIL-L-2104 B as well as to specification MIL-L-2104 A, Supplement 1. Oils complying with the new specification MIL-L-46152 and with the former specification MIL-L-45199 B or with the specification S 3 are also in conformity with the required oils grades.
- ** HD-C oils are motor oils corresponding to the new specification MIL-L-2104 C.

* Heavy operating conditions are understood to be: Long idling periods of the engine, long-lasting ambient temperatures above +30° C, operation in winter, combine harvester and crawler tractor duty.

** For examples see on page 36.

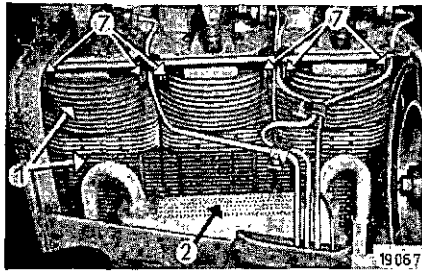

Fig. 22

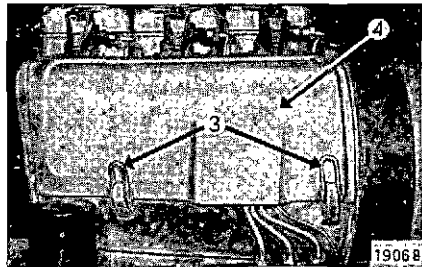

Fig. 23

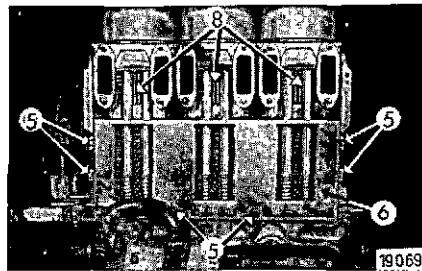

Fig. 24

B 7 Cleaning the Cooling Fins

every 120 running hours, in very dusty conditions more frequently.

Fin cleaning is essential since accumulation of dust on fins 1 (Fig. 22) of cylinders and heads as well as on oil cooler 2 is liable to reduce cooling efficiency substantially.

Proceed by releasing fasteners 3 (Fig. 23) on the injection pump side and removing air cowling 4. Next release bolts 5 (Fig. 24) on the exhaust side and remove baffle 6.

As to the actual cleaning method, it is advisable to use dry means, e. g. a wire and, if possible, compressed air. Take special care to clean the vertical cylinder head cooling fins 7 (Fig. 22) and 8 (Fig. 24).

Carefully clean also the fins of the oil cooler 2 (Fig. 22), if fitted. Start blowing through from the exhaust side.

If diesel fuel or a cold cleansing agent is used for cleaning, it is important, after allowing an adequate soaking-in period, to wash the engine parts with a powerful water-jet. Following this, the engine should be run until warm so that any water left behind will be evaporated before rust can form.

If a steam-jet is available, this method of cleaning is preferable to any other.

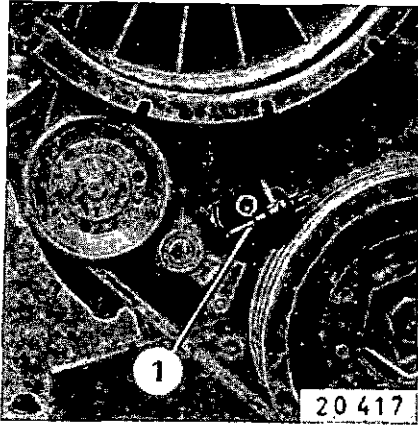

Fig. 25

B 8 Checking the Warning Device*

every 120 running hours. Give the pin 1 (Fig. 25) a pull up. This will cause the electric stop switch to give an audible or visual warning signal.

In the event of V-belt failure the idler pulley will operate the stop switch via pin 1.

B 9 Checking Electrolyte in Battery

every 120 running hours but a least once a month. Check the electrolyte level in each cell after unscrewing caps 1 (Fig. 26). In some cases electrolyte level testers 2 are provided: the level should be high enough to wet the bottom of these. An alternative method is to insert a clean wooden stick 3 into the cell until it touches the top of the lead plates. The electrolyte should wet the stick over a length of about 10–15 mm (0.4–0.6 in). If the electrolyte level is low, top up with distilled water only. Owing to the danger of short circuits never rest tools on the battery. The battery should be taken to a workshop from time to time for a check on its charge. For hints on battery care in winter see page 11.

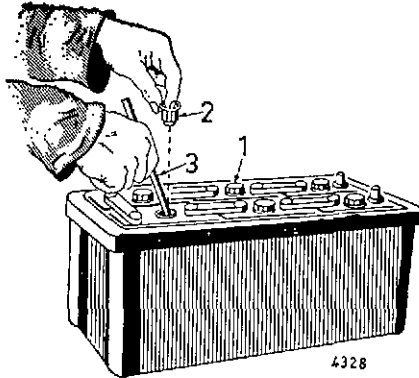

Fig. 26

* Only fitted to order and on special models.



Renewing the Oil Filter Cartridge

every 200 to 240 running hours. Loosen cartridge 1 (Fig. 27) with mandrel or screwdriver 2 and screw off by hand. After slightly oiling rubber gasket 3 (Fig. 28), screw new cartridge in place until gasket is squarely seated and give the assembly a final half turn.

Cartridge spare Nos. are as follows:

3-cyl.: A 1 H 4123

4-cyl.: A 1 H 4123

5-cyl.: A 1.5 H 4123

6-cyl.: A 1.5 H 4123

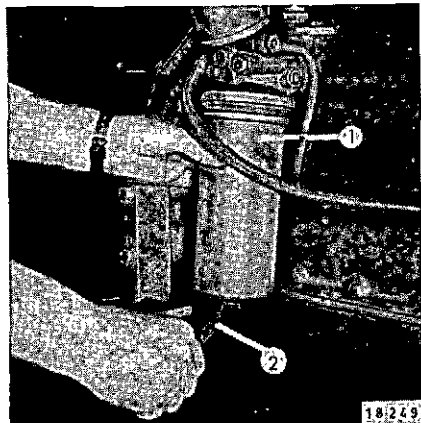

Fig. 27

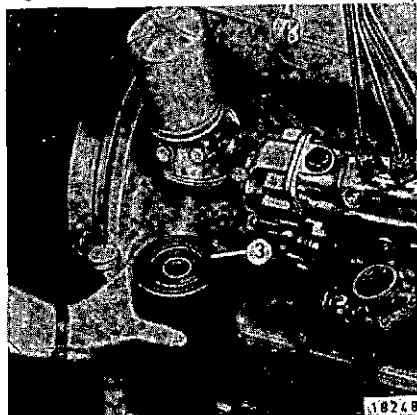

Fig. 28

During service following assembly check oil pressure and filter tightness.



B 11 Checking Valve Clearance*
(Fig. 29 and 30)

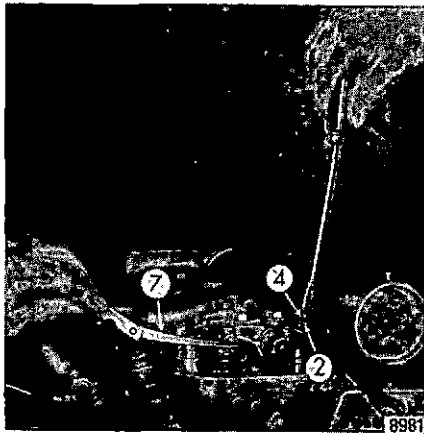

Fig. 29

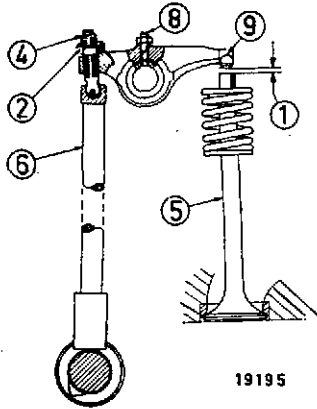

Fig. 30

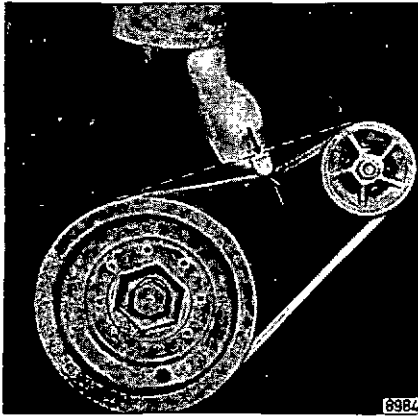

Fig. 31

at 1st and 2nd oil changes and later, under normal working conditions, every 240–360 running hours.

Where working conditions are severe, e. g. heavy load variation, stop-and-go duty, or high dust content of air, the valve clearance should generally be checked at shorter intervals.

Check clearance with engine cold by means of a 0.15 mm (0.006 in.) feeler gauge 7 (Fig. 29). To do this, turn crankshaft at front end until the piston of the cylinder in question reaches the compression dead center, i. e. after overlapping of both valves (exhaust valve about to close, inlet valve about to open), go on turning the crankshaft through 360°, corresponding to a complete revolution. Valve clearance 1 is correct when the feeler gauge can be inserted with a slight drag in the gap 1 between rocker arm 9 and valve 5, both inlet and exhaust. If not, loosen lock nut 2 of adjusting screw 4 through one or two turns and adjust by means of a screw driver.

Check that the punch mark above the bevel on oil nozzle 8 points to rocker arm pad 9, to maintain lubrication under idling conditions.

* As engine performance is essentially governed by this clearance 1 between rocker arm pads 9 and valve stems 5, it may be preferable to have the adjustment carried out by a skilled mechanic.

B 12 Checking V-belt Tension

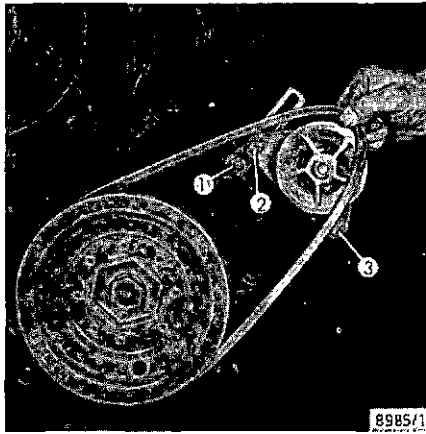

Fig. 32

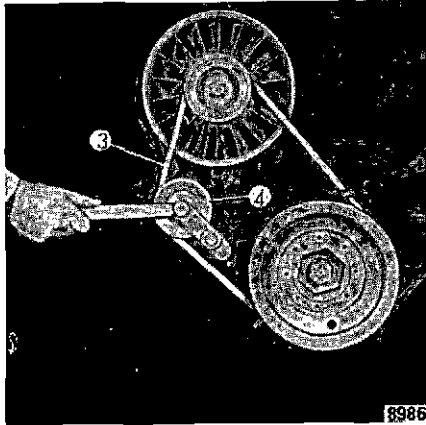

Fig. 33

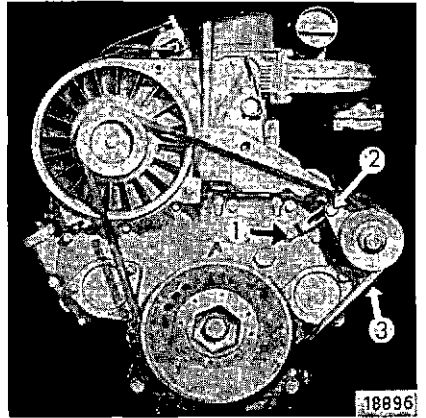

Fig. 34

every 240 running hours. Check by pressing with the thumb (Fig. 31) to see whether the generator V-belt deflects inwards by max. 10–15 mm (0.4–0.6 in). If the belt requires re-tensioning slacken hex. nut 1 in (Fig. 32) and securing bolts 2 and 3. Push the generator outwards until the correct belt tension is obtained. Finally, securely retighten hex. nut 1 and bolts 2 and 3.

A new generator V-belt should be pulled up tight after a short period of service and in any case not later than at the end of 40 running hours.

For generator belt replacement (Fig. 32) slacken hex. nut 1 plus bolt 2, and press generator toward engine as far as it will go.

For blower belt 3 replacement (Fig. 33) all you have to do is to push idler pulley 4 vigorously inwards.

Where a **common** V-belt for generator and blower is provided (Fig. 34), adjust tension as follows: Slacken hex. bolts 1 and 2 as well as screw 3, press generator outwards until correct tension is obtained, and retighten bolts and screw.

To avoid damage to the V-belts, remove or refit the belts without screwdriver or other tools.

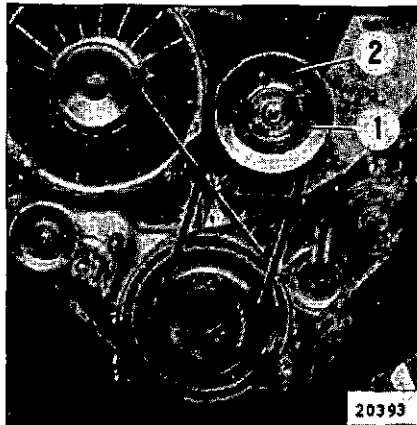

Fig. 35

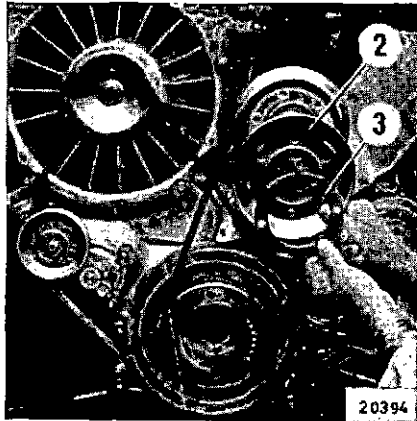

Fig. 36

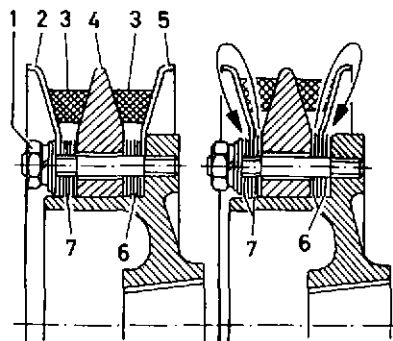

Fig. 37

Retensioning single-type V-belt on compressor

1. Unscrew hex. bolts 1 (Fig. 35).
2. Take down outer half-pulley 2.
3. Remove one or more shims 3 (Fig. 36) — as may be required — from inside and place removed shim(s) outside on half-pulley 2.
4. Retighten bolts 1 (Fig. 35) while turning over the engine with the turning device to prevent the belt to be squeezed.

Retensioning twin-type V-belt on compressor

1. Unscrew hex. nuts 1 (Fig. 37).
2. Take down half-pulleys 2 and 5 together with shim packs 6 and 7 as well as intermediate piece 4.
3. For the purpose of retensioning the belts, take one or more shims — as may be required — from packs 6 and 7 and place them before or behind the half-pulleys to ensure alignment of the belts. The number of shims taken from each pack at the same time must always be the same.
4. Retighten hex. nuts while turning over the engine with the turning device to prevent the belts to be squeezed.

Where two V-belts are provided, always renew both belts when only **one** is worn or damaged. The difference in length of the new V-belts may not exceed 0.15 %.

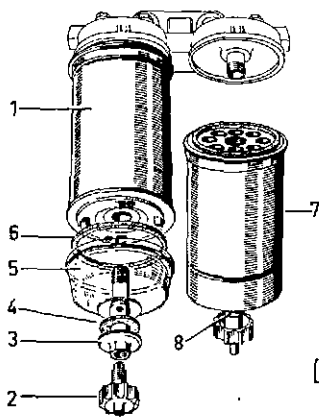

Fig. 38

B 13 Renewing the Two-stage Fuel Filter (1st stage)

every 240 running hours or earlier if power output decreases. If the cartridge is to be renewed earlier because of loss of power, this means that the fuel is soiled. Check the fuel tank for cleanliness and its cover for tightness.

To replace cartridge 1 (Fig. 38) unscrew drain plug 2 and, by means of a screwdriver, release clamping pin 3 thus bared.

Remove transparent water bowl 5 and the two seals 4 and 6. Unscrew cartridge from bracket and replace cartridge. Refit water bowl in reverse order taking care that seals 4 and 6 are properly seated.

B 14 Renewing the Two-stage Fuel Filter (2nd stage)

every 1,200 running hours. Unscrew cartridge 7 (Fig. 38) complete with drain plug by utilizing hexagon 8 at bottom part.

To ensure good filtering efficiency, it is advisable not to renew both cartridges at the same time.

Spare Nos. of filter cartridges:

1st stage No. 213 3558

2nd stage No. 213 3943

B 15 Renewing the Single Fuel Filter*)

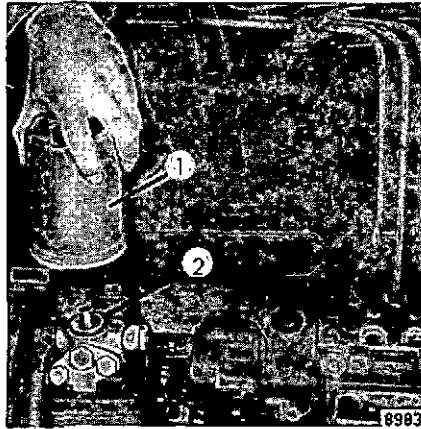

Fig. 39

every 1,200 running hours or earlier if power output falls off. If the cartridge is to be renewed earlier because of loss of power, this is a sign that the fuel is soiled. Check the fuel tank for cleanliness and its cover for tightness. Screw off the expendable cartridge 1 (Fig. 39) with care as the fuel will run out and clean seat 2 if necessary.

For reassembly, slightly oil rubber seal and screw new cartridge in place until seal is squarely seated. Then give assembly a final half turn.

Air-vent filter as described on page 12.

After restarting engine, check that the filter assembly is actually tight.

The spare No. of the expandable cartridge is:
116 0243

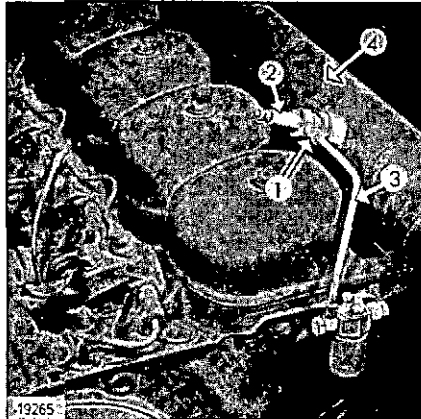

Fig. 40

B 16 Testing the Heating Tube or Flame-type Heater Plug before the Cold Season begins or in Case of Starting Difficulties.

For checking the function of the heating tube or the flame-type heater plug, preheat approx. 1 minute with the heater plug/starter switch in position 1. In doing so, a distinct warming up of the heating tube close to the electric line connection must be felt with your hand. If a flame-type heater plug is provided, the heater plug indicator must brightly light up.

For checking the fuel supply of the flame-type heater plug, loosen by a few turns the pipe coupling 1 (Fig. 40) of the flame-type heater plug. Then — without preheating in position 1 — switch at once to position 2 to turn engine by starter motor. In doing so, fuel must emerge at the slackened pipe connection. If no fuel emerges, this trouble must be remedied in the shop.

Should the engine fail to start, despite fuel emerging at the loosened pipe coupling, the flame-type heater plug 2 must be removed and checked for free flow. To do this, connect fuel line 3 to the heater plug in removed condition and start the engine for a brief period. Clogged flame-type heater plugs must be renewed.

When the flame-type heater plug functions properly, the intake pipe 4 close to the heater plug must warm up when starting the engine.

* The fuel filter has an essential function since injection pump and nozzles are high-precision items which can properly operate only on perfectly clean fuel.

Workshop Maintenance

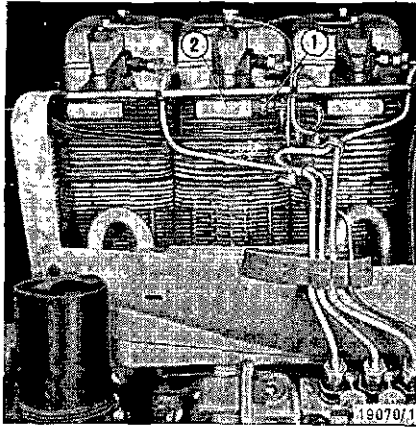

Fig. 41

W 1 Remote-reading Thermometer

Every 600 running hours the sensitive element 1 (Fig. 41) should be unscrewed from cylinder head 2, and immersed in oil at 150–155° C (302° F to 311° F). This should cause the red "stop" sector to appear in the window of the indicator.

The sensitive element is always screwed into the head of the 2nd cylinder.

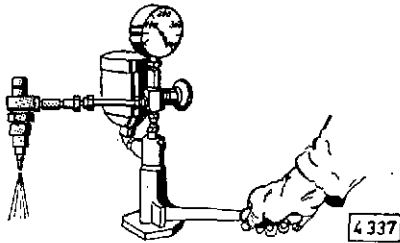

Fig. 42

W 2 Injectors

Every 600 running hours the injectors should be taken down and properly cleaned in diesel fuel. Following this they should be tested to see that they give the injection pressure of $175 \pm 8 \text{ kg/cm}^2$ (2483.1 p.s.i.) specified for DEUTZ engines. (Check that all four jets issue evenly.) This test is best made with the aid of a nozzle tester (Fig. 42).

W 3 Intake and Exhaust Manifolds

Every 600 running hours, check fixation at cylinder heads for leaks and tighten up if necessary.

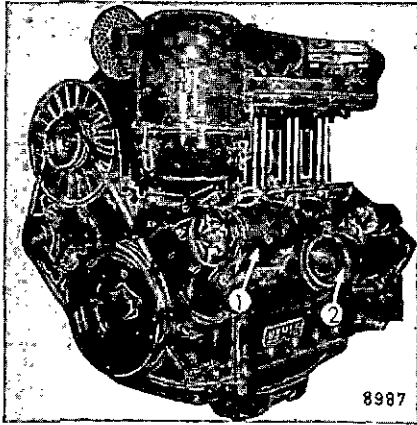

Fig. 43

W 4 Dynamo

Every 600 running hours it is advisable to have dynamo 1 (Fig. 43) inspected by a specialist.

W 5 Alternator

Every 1,200 running hours it is advisable to have the alternator inspected by a specialist.

Unlike the dynamo, the alternator supplies power already when the engine is idling, thus providing for full battery charge at all times.

Service the three-phase system as follows:

1. When the engine is **running**, never disconnect the leads between battery — alternator — tension regulator. Where it is however necessary to operate the engine without battery, disconnect alternator from tension regulator.
2. Never confuse the battery connections.
3. Replace any defective charging pilot light immediately.
4. Before washing the engine, protect alternator and tension regulator.
5. To check whether the three-phase system is "live", be sure never to produce a transient short-circuit with the positive lead against the earth lead, a procedure usually adopted for D. C. systems.
6. In case of electric welding, connect the earth terminal of the welding apparatus direct to the piece to be welded.

W 6 Starter motor

Every 1,200 running hours it is advisable to have starter motor 2 (Fig. 43) inspected, especially if the motor is frequently used.

W 7 Injection Pump

Every 3,000 running hours have the injection pump inspected in a service station.

Trouble Chart

If troubles should occur, these will be frequently due to incorrect operation, lubrication or maintenance of the engine. In such a case, therefore, make a point of thoroughly re-reading the Sections on pages 5 to 31. If you cannot identify the cause of the trouble or are unable to put it right yourself, then your best plan is to contact your local DEUTZ distributor.

Trouble	No.	Cause	Remedy	Further details on page
A Engine fails to start	1	Fuel tank empty	Fill up tank and air-vent	12
	2	Shut-off valve closed	Open shut-off valve and air-vent if necessary	12
	3	Strainer in fuel lift pump blocked	Clean strainer	21
	4	Fuel filter blocked; in winter through fuel clouding	Renew filter and then air-vent; use winter-grade fuel	31 12 10
	5	Fuel lines leaking	Check all fuel line connections for tightness	
	6	Charging pilot lamp fails to light up although bulb is not defective	Turn switch key clockwise to first detent, tighten terminals on battery, check wiring	7
B Engine is difficult to start	7	Battery low, battery terminals loose or oxidized causing starting motor to turn slowly	Have battery inspected, clean terminals, tighten and coat with acid-free grease	25
	8	Grade of motor oil used is too viscous (applies particularly in winter)	Choose grade of motor oil suited to temperature conditions	9 23
	9	Fuel supply not sufficient; in winter blockage by clouding	Renew fuel filter and then air-vent, clean strainer in fuel lift pump, check fuel line connections for tightness; use winter-grade fuel	31 12 21 10

Trouble	No.	Cause	Remedy	Further details on page
C Engine gives poor performance	10	Fuel supply not sufficient	Renew fuel filter and air-vent Clean strainer of lift pump Tighten fuel line connections	31 12 21
	11	Valve clearances out of adjustment, valve spring broken	Readjust valve clearances, fit new valve spring	27 38
	12	Nozzle needle sticking	Have inspected by specialists	32
D Exhaust smokes badly	13	Too much oil in sump	Drain off until level reaches top mark on dipstick	18
	14	Oil level in oil bath air cleaner too high	Pour off until level agrees with mark	18
	15	Inefficient compression due to sticking or broken compression rings or incorrect valve clearances	Have compression rings and pistons inspected by specialists Readjust valve clearances	27
E Engine overheats (causing temperature indicator to display "STOP") (Shut down engine immediately)	16	Cooling fins on cylinders and cylinder heads very dirty	Clean cooling fins, particularly the vertical ones on the cylinder heads	24
	17	Injectors defective	Have inspected by specialists	32
	18	Injection pump delivery out of adjustment	Have adjusted by specialists	33
	19	Insufficient cooling air input to blower	Make sure that air can enter blower freely	40
	20	Blower V-belt broken	Replace V-belt	28
F Engine oil pressure too low (Shut down engine immediately)	21	Leaks in lubricating oil system	Check connections on pump, lines, filter, pressure gauge and cooler for tightness.	
		Excessive main bearing clearance	Have adjusted consult specialists	
G Charging indicator lamp lights up while engine is running	22	Generator speed too low	Check V-belt tension	28
	23	Generator not charging battery because generator or tension regulator defective	Have inspected by specialists	33

List of Recommended Lube Oils

(Effective summer 1974, not exclusive*)

According to the suppliers, the brands listed below are of **HD-S1** quality as described under section B 6 on page 23.

Oil Company	Brand of Oil
ARAL	ARAL AUTORAL
BP	BP DIESEL MOTOROEL HD, BP ENERGOLIC-D, BP ENERGOLIC-M
CASTROL	CASTROL HD, CASTROL/DEUSOL CRI
DEUTZER OEL-GES.	DEUTZ OIL SGHD
ESSO	ESSO ESTOR HD, ESSOFLEET HD
FINA	FINA SOLNA HD S 1
MOBIL	DELVAC 1130, MOBILGARD 312
RHEIN. MOTOR-OEL	RMV-HD-MOTOR OIL EXTRA SPECIAL RMV; High-quality Motor Oil 1315 H
TEXACO	TEXACO GARANT HD
VEEDOL	VEEDOL MOTOR OIL CADEL HD M
WENZEL & WEIDMANN	ECUBSOL-MOTOR OIL EXTRA HD

According to the suppliers, the brands listed below are of **HD-B** quality as described under B 6 on page 23.

Oil Company	Brand of Oil
ARAL	ARAL SUPER, ARAL KOWAL, ARAL SUPER KOWAL, ARAL SPECIAL ARAL MOTORAL
BP	BP VANELLUS-T, BP VANELLUS M, BP ENERGOL HD, BP ENERGOL DS-B, BP SUPER VISCOSTATIC
CASTROL	CASTROL/DEUSOL CRB
CHEVRON	CHEVRON DELO SPECIAL MOTOR OIL, DELO 200 MOTOR OIL, DELO 300 MOTOR OIL
DEUTZER OEL-GES.	DEUTZ OIL HD SUPER DB, SGHD-B/2X
ESSO	ESSOLUBE SDX, ESSO ESTOR SDX, ESSOLUBE HDX, ESSO MOTOR OIL
FINA	FINA DELTA PLUS MOTOR OIL, PURFINA MOTOR OIL or FINA DELTA MOTOR OIL, FINA SOLNA S 3
FUCHS	RENOLIN HD, PENA PURA HD, PENA PURA HD SUPER, PENA PURA LD EXTRA, PENA PURA HD SUPERIOR, PENA PURA HD SUPER N TITAN 10 W-50
MOBIL	DELVAC 1130, DELVAC 1230, MOBILGARD 312
RHEIN. MOTOR-OEL	RMV-HD Emblem, RMV-HD Emblem DB, RMV-RHEMOTOL HD S 3
SHELL	SHELL ROTELLA SX, SHELL ROTELLA TX
TEXACO	URSA OIL ED, ULTRA MOTOROIL, ULTRA ALL TEMP, URSA OIL S 3, URSA OIL LA 3
VALVOLINE	VALVOLINE SUPER ALL CLIMATE, RITZOL SUPER HDX, LOROCO HD (DBM), VALVOLINE HD SUPER, HPO D. B.
VEEDOL	VEEDOL MOTOR OIL CADEL HD 900, VEEDOL SUPER 10/40 VEEDOL SUPER 20/50, VEEDOL MOTOR OIL CADEL HD S 3
WENZEL & WEIDMANN	ECUBSOL MOTOR OIL EXTRA HD, ECUBSOL SUPER OIL HD

According to the suppliers, the brands listed below are of **HD-C** quality as described under section B 6 on page 23.

Oil Company	Brand of Oil
ARAL	ARAL TURBORAL
BP	BP VANELLUS C 3, BP ENERGOL DS-3
CASTROL	CASTROL/DEUSOL CRD, CASTROL/DEUSOL CRF
CHEVRON	DELO 400 MOTOR OIL
DEUTZER OEL-Ges.	DEUTZ OEL SGHD-G
ESSO	ESSOLUBE D-3, ESSOLUBE D-3 HP, ESSO ESTOR D-3
FINA	FINA KAPPA MOTOR OIL
FUCHS	PENA PURA UNIVERSAL HD
MOBIL	DELVAC 1330
SHELL	SHELL MYRINA, SHELL RIMULA CT
TEXACO	TEXACO URSA OIL LA 3
VALVOLINE	TOPFLITE CS-3, RITZOL HD C-3
VEEDOL	VEEDOL ADELBUS HD-C
WENZEL & WEIDMANN	ECUBSOL SUPREMA C/S 3 HD

*) The above oil brands are quoted as examples of oils meeting our quality requirements. Other oil brands may also be used, of course, provided they correspond in quality to these specified.

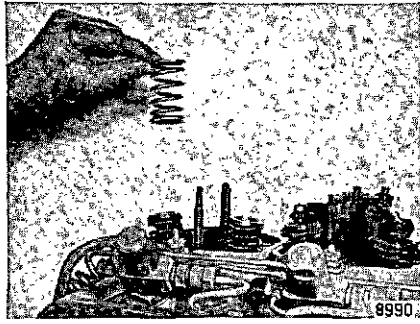

Fig. 44

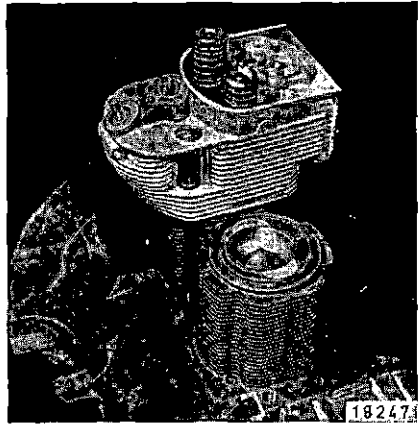

Fig. 45

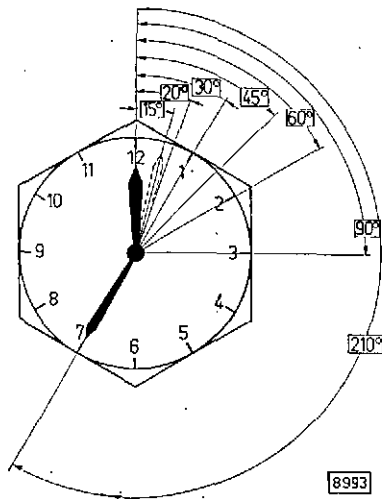

Fig. 46

Hints for the Mechanic

The English version of the Workshop Manual for the engine series dealt with in this booklet can be obtained from the Cologne Spare Parts Dept. under the parts number 291 1842.

When fitting a valve spring be sure that the more closely wound end of the spring is at the bottom (Fig. 44).

When fitting a new piston, be sure that the arrow marked on the piston points to the exhaust-air side (Fig. 45).

Tightening Highly-Stressed Bolts (Studs)

The following information is intended in particular for mechanics who may have to carry out repairs on these engines but who do not belong to the DEUTZ/MAGIRUS organization.

To prevent incorrect assembly, the following notes include some instructions on the tightening of the bolts and studs since the procedure differs from that usually employed. The final tightening angle is specially important in this connection and for this reason. Fig. 46 indicates how various angles can be readily obtained by comparison with a clock face. To obtain the required angle, it is only necessary to turn the tommy bar of the spanner through the same angle as that included between the large and the small hands of the clock. Also, the angle of 60° of a hex. bolt head can serve as a guide.

1. **Wet threads and seatings with motor oil before fitting.**
2. **Screw the bolts in** until they are squarely seated, using a socket spanner without tommy bar or, in the absence of a socket spanner, a box or ordinary spanner without making use of the leverage.
3. **Pre-load the bolts** by holding the tommy bar in such a manner that both hands are in contact with the spanner. When using a box or ordinary spanner for pre-loading, the tip of your straight thumb holding the spanner must touch the head of the bolt.
4. **Tighten the bolts** according to the Instructions on page 38, if necessary in stages in conformity with the tightening angles specified.

Bolt Tightening Table (Screws and Studs)

Designation		Pre-loading mkp	Tightening				Note
			1st stage	2nd stage	3rd stage	Total	
Cylinder head bolt	M 10 1681	3	45°	45°	45°	135°	3,5 mkp
Connecting rod	M 12 x 1,5 x 55	3	60°	30°	—	90°	
Bearing cap	M 14 x 110	3	60°	45°	—	105°	FL 911/912
Idler gear	M 10 x 60	3	60°	—	—	60°	
Balance weight	M 12 x 60	3	30°	30°	—	60°	
Flywheel	M 10 x 1 x 35	3	60°	30°	—	90°	waisted bolt H 803 bolt DIN 961
Flywheel	M 10 x 1 x 40	3	60°	30°	—	90°	waisted bolt H 803 bolt DIN 961
Flywheel	M 10 x 1 x 45	3	60°	30°	—	90°	waisted bolt H 803 bolt DIN 961
Flywheel	M 10 x 1 x 50	3	60°	30°	—	90°	
Fixation of injector	M 10 DIN 934-8 B4C			—	—		
V-belt pulley	M 24 x 2 x 110	5	210°	—	—	210°	
Cooling blower	M 12 x 140	3	60°	30°	—	90°	F 3/4 L
Cooling blower	M 12 x 180	3	60°	30°	—	90°	F 5/6 L
Filter carrier	M 10 x 160	3	60°	60°	30°	150°	
Dynamo/Alternator	M 10 x 180 M 10 x 230	3 3	60° 150°	—	—	180° 150°	
Idler pulley	213 6384	3	45°	—	—	45°	
Engine suspension	M 14 x 100	3	60°	15°	—	75°	
Engine suspension	M 14 x 110	3	60°	45°	—	105°	
Engine suspension	M 14 x 125	3	60°	45°	—	105°	
Advance/retard unit	—	—	—	—	—	—	6 + 1 mkp

When renewing main and big-end bearings or after piston seizures, be sure to renew the bearing bolts too.

To dismantle the injection pump, an extracting tool, Order No. 1-1-034-0, is necessary. This can be ordered from Head Office (Dept. SKK). To loosen the slotted nut in the case of drive with advance/retard unit, a 20 mm-wide screwdriver can be used. A universal-joint spanner (17 mm a/f) should be used to undo the four hex. nuts at the injection pump flange.

Hints on Installing the Engine

Take all precautions to ensure that hot air exhausted from the engine cannot be re-circulated. In fact, if such hot air is taken in by the cooling blower, this will cause engine overheating; if taken in for combustion, the power output will fall off.

Where it is advisable to provide special exhaust-air discharge ducting, we shall be glad to offer suitable equipment.

The zone from which cooling and combustion air is drawn should be as clean as possible, and we shall gladly advise you in this respect, too:

Do not hesitate, therefore, to call in one of our installation specialists at an early date!

Engine Preservation

If your engine is to be shut down for a major period (e. g. over the winter), we recommend the following preservative measures against rust formation.

1. Clean the outside of the engine with diesel fuel or benzine.
2. Drain the engine oil in hot condition and fill in corrosion inhibitor oil*).
3. Pour the oil out of the air cleaner bowl, clean bowl and fill in inhibitor.
4. Drain fuel from tank, mix well with 10 % inhibitor and fill back into tank. Instead of adding inhibitor oil to the fuel, the tank can be filled up with injection pump testing oil having corrosion inhibiting properties (e. g. Calibration Fluid B).
5. Drain or draw off oil from injection pump and governor and refill with corrosion inhibitor oil.
6. Run engine for about 10 minutes, so that pipes, filter, pump and nozzles are filled with the preservative mixture and the new motor oil is distributed to all parts.
7. After this run, detach the rocker chamber covers and the lateral cover of the injection pump and spray the rocker chambers as well as the spring chamber of the injection pump with a mixture of diesel fuel and 10 % anti-corrosive or with injection pump testing oil. After this, refit the covers.
8. Now turn the engine over several times without firing in order to spray the mixture into the combustion chambers.
9. Detach V-belts and spray the pulley grooves with corrosion inhibitor. Remove inhibitor before reusing the engine.
10. Tightly close openings of oil bath air cleaner intake and exhaust pipe.

These measures will give about 6 to 12 months protection, depending on weather effects. Before putting the engine back to use, replace the preserving oil by fresh motor oil. Where only temporary operation for not more than 10 hours and only at partial load is envisaged, the preserving oil may be retained.

* Shell-Ensis 20 or equivalent

Please note

The Maintenance Schedule illustrated overleaf is supplied with each engine as self-adhesive "sticker". This is to be adhered to the engine or to the equipment at a conspicuous point.

Should this Schedule be missing, ask your engine or equipment dealer to supply you with one.

SUMMARIZED INSTRUCTIONS

Checking Engine Oil Level

Starting

1. Isolate driven equipment by **declutching**.
2. Set speed control lever to 1/4 speed.
3. Insert starter key and turn clockwise. Do not operate starter motor uninterruptedly for more than 10 seconds.
Starting with distributor injection pump see page 8.

After Starting

1. Check oil pressure.
2. Re-check oil level after a short trial run of engine.

Stopping

Never shut engine down suddenly from full load running, but let it idle for a short time to permit temperature balance.

1. Move speed control lever back.
2. Operate stopping lever until engine comes to rest.
3. Withdraw starter key

	3-cyl.	4-cyl.	5-cyl.	6-cyl.
Total filling for oil changes (ltr.)	8	9.5	12	12

Designation of filter cartridges

Lube oil filter cartridge

for 3-cyl. engine	} A 1 H 4123
for 4-cyl. engine	
for 5-cyl. engine	
for 6-cyl. engine	} A 1.5 H 4123

Fuel filter cartridge:

In-line injection pump No. 1 160 243

Distributor-type injection pump:

1st stage No. 213 3558

2nd stage No. 213 3943

MAINTENANCE SCHEDULE

