

INSTRUCTION MANUAL

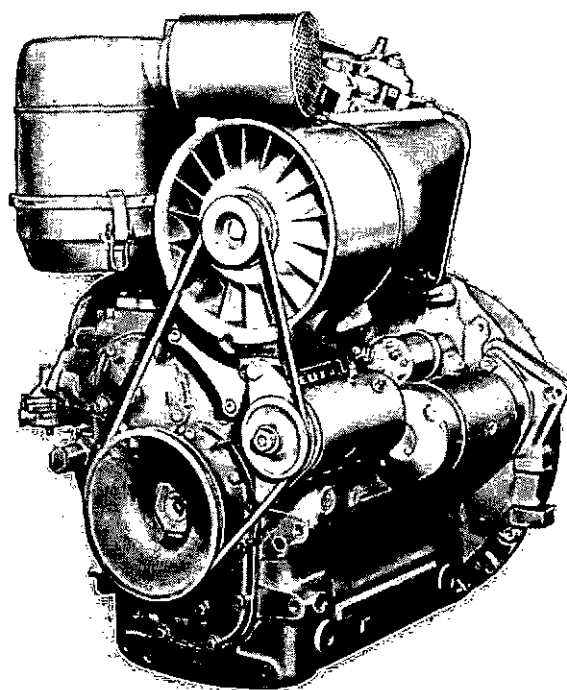

F2L912

F2L912W



297 1566 UF 0155-99

E

**Before putting the new engine into service
please read this booklet carefully**

Your engine was given a bench test before leaving our works. This proved that all the component parts function correctly and the required power output is attained. No doubt you wish to keep your engine at peak operating efficiency at all times, just as we are equally anxious that it should be your constant, dependable and trusty aid. To make this possible you should comply precisely with all the operating and maintenance instructions, and then you will always find it a pleasure to use your DEUTZ engine.

However, should you experience troubles, please contact your DEUTZ dealer, who will gladly be of assistance in remedying any defects. Remember that only at the repair shops displaying the DEUTZ sign will you find properly trained mechanics provided with all the essential special-purpose tools and equipment. And only there will you be able to obtain genuine spare parts bearing the DEUTZ quality symbol.

This symbol alone ensures that you will be getting the best, the genuine spare parts which alone carry our full guarantee.

Therefore always insist on



When ordering these spares please quote the references contained in the Parts List supplied with your engine.

We trust that your DEUTZ engine will do you a power of good at your work- whatever it may be.

Klöckner-Humboldt-Deutz AG



CONTENTS

	Page
Cut-away view of Engine	2
Lube Oil Circuit	3
Specification Data	5
<hr/>	
Operation of Engine	6
Fuel	6
Motor Oil	6
F2L 912	
Starting	8
Stopping	9
F2L 912 W	
Starting	10
Stopping	12
<hr/>	
Hints for Winter Operation	12
<hr/>	
Air-venting the Fuel System	15
<hr/>	
Maintenance Schedule	16
Notes on Maintenance Schedule	20
<hr/>	
Workshop Maintenance	27
<hr/>	
Preservation of Engine	28
<hr/>	
Troubles – Causes and Remedies	29
<hr/>	
For the Specialist	
<hr/>	
Tightening Screwed Joints	33
Hints for Installing the Engine	34
<hr/>	
Fuel Piping	36
Summary Instructions see back cover	

Editing Department ASJ
Issuing Department MMLV

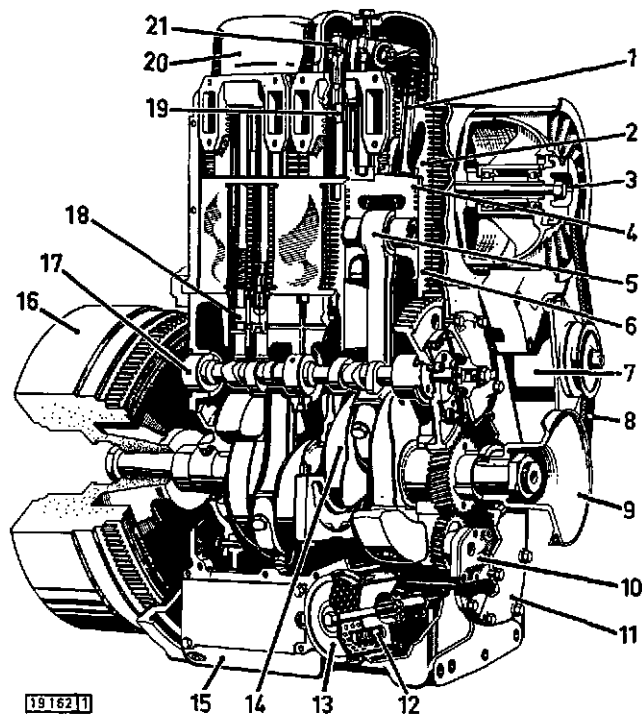

Figure 1

Cut-away view of Engine F2L 912/W

- | | |
|----------------------------------------------------------------|------------------------------------|
| 1 Inlet valve | 11 Front cover |
| 2 Cylinder head (light metal) | 12 Safety valve in lube oil filter |
| 3 Cooling blower | 13 Lube oil filter with cartridge |
| 4 Piston (light metal) | 14 Crankshaft (forged steel) |
| 5 Connecting rod (forged) with replaceable finish-bored shells | 15 Crankcase (cast iron) |
| 6 Finned cylinder (grey cast iron, separately removable) | 16 Flywheel with ring gear |
| 7 Generator | 17 Camshaft |
| 8 V-belt driving generator and cooling blower | 18 Tappet |
| 9 V-belt pulley | 19 Pushrod |
| 10 Lube oil pump | 20 Cylinder head cover |
| | 21 Rocker arm |

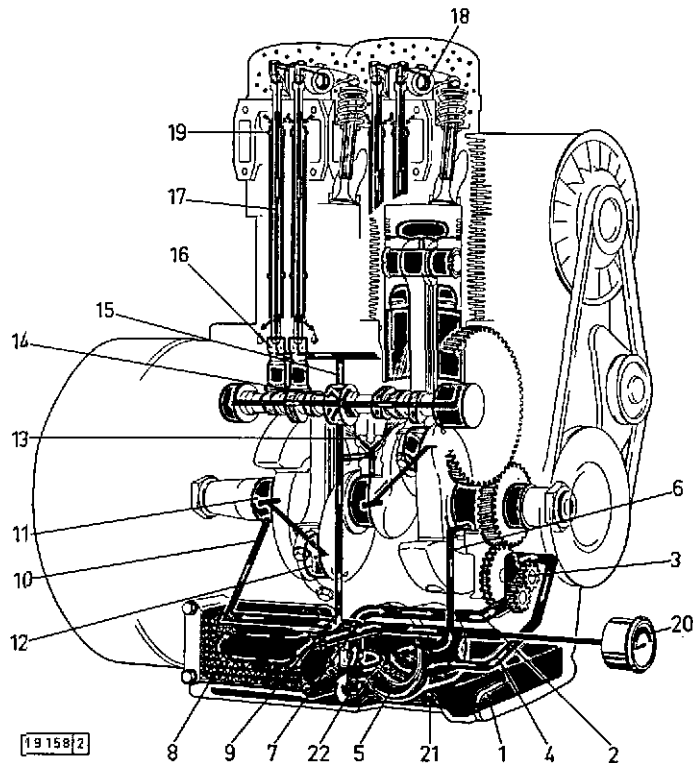

Figure 2

Lube Oil Circuit F2L 912/W

- | | |
|--------------------------------------------------------------------------------------|------------------------------------------------------------------------|
| 1 Oil sump | 14 Camshaft bearing |
| 2 Intake pipe | 13 Spray nozzle for piston cooling |
| 3 Lube oil pump | 15 Oil gallery to tappets |
| 4 Delivery line | 16 Tappet (with groove for impulse lubrication of rocker arms) |
| 5 Oil filter with cartridge (in main flow) | 17 Pushrod (hollow, for oil flow to rocker arms) |
| 6 Oil port to 3rd crankshaft bearing | 18 Rocker arm bearing |
| 7 Oil port to oil cooler | 19 Pushrod cover tube (for oil return from cylinder head to crankcase) |
| 8 Oil cooler (depending on version) | 20 Oil pressure gauge |
| 9 Oil port to 2nd crankshaft bearing, to valve operating gear and for piston cooling | 21 Oil drain plug of lube oil filter body |
| 10 Oil port to 1st crankshaft bearing | 22 Main oil drain plug |
| 11 Main bearing | |
| 12 Big-end bearing | |

Note

This Instruction Manual applies both to engine F2L912 (with direct injection) and engine F2L912W (with two-stage combustion system).

The difference of the two systems and their operation is dealt with in the sections „Specification Data“, „Starting“ and „Operation in Winter“.

Engines provided with direct injection are destined for such applications where high power output combined with little space requirement is of more importance than best exhaust gas quality.

Two-stage combustion engines, on the other hand, are to be recommended where power output may be somewhat less but where the least possible nuisance by exhaust gases is of great importance.

Specification Data

Model	F2L 912	F2L 912 W
Number of cylinders	2	
Bore mm (in.)	100 (3 ¹⁵ / ₁₆)	
Stroke mm (in.)	120 (4 ²³ / ₃₂)	
Piston displacement cm ³ (cu.in.)	1885 (115)	
Direction of rotation (facing flywheel)	(counter-clockwise)	
Working principle	four-stroke diesel with direct injection two-stage combustion	
Weight (depending on version) . . . approx. kg (lbs)	255 (562)	
Power output* HP	see rating plate	
Speed rev/min	see rating plate	
Lubrication system	forced lubrication	
Oil capacity		
initial fill approx litre (imp. gall.)	6 (1.32)	
refill approx litre (imp. gall.)	4.5 (1.0)	
Valve clearance (engine cold) mm (in.)	0.15 (0.006)	
Inlet valve open	26° C.A. before TDC	
Inlet valve close	67° C.A. after BDC	
Exhaust valve open	73° C.A. before BDC	
Exhaust valve close	30° C.A. after TDC	
Piston crown clearance (measured with lead wire) mm (in.)	1.0-1.2 (0.040 to 0.047)	
Injection pressure atm (psi)	175+8 (2489.1)	125+8 (1777.9)
Commencement of injection		
up to 2300 rpm C.A. bef. TDC	32° ± 1°	27° ± 1°
above 2300 rpm C.A. bef. TDC	38° ± 1°	27° ± 1°
Firing order	1-2	

* Power output and speed depend in each individual case on the application of the engine.
 In view of the constant improvement to our engines, the above specification data, illustrations and other information included in this booklet are not binding and subject to change without notice; no claims may, therefore, be inferred herefrom.

Tachometer

Where a mechanical tachometer with hourmeter is fitted, the operating hours can accurately be determined by multiplying the recorded hours by the factor given in the table below.

Engine rpm	Factor	Engine rpm	Factor
1500	× 1	2150	× 0.7
1800	× 0.85	2300	× 0.65
2000	× 0.75	2500	× 0.6

Example:

Indicated Operating Hours	Factor at 2000 rpm	Actual Operating Hours
20	× 0.75	= 15

Engine Operation

Starting up of a new engine for the first time involves a number of preparatory jobs. Some of these, however, are not confined just to the first time of starting up a new engine. They must also be carried out later on in the course of routine maintenance (see Maintenance Schedule on page 16).

1. Fuel

- Always use a reputable branded grade of fuel (gas oil), the sulphur content of which should be below 0.5 %, and observe strict cleanliness when filling in. At low ambient temperature use only winter-grade fuel (see hints on page 12). The fuel must be replenished promptly to prevent the tank from running dry, otherwise the injection pump, fuel filters and injection lines will need air-venting. Instructions to this effect are given on page 15. Our engines leave our works without any fuel in the tank, and air-venting must therefore be carried out before starting up for the first time.

2. Oil Change and Checking Oil Level (see page 20, B 1)

2.1 Oil Quality

During operation of the engine not only part of the oil lubricating the pistons is burnt ("consumed"), but the thermal stress and the combustion residues mixing with the oil also entail a degradation of the oil and in particular of its chemical additives. Therefore, a complete change of the oil has to be carried out at the recommended intervals.

As this "degradation" is greatly influenced by the operating conditions as well as by the quality of the fuel and that of the oil ("lubricity"), the oil change intervals differ accordingly. Therefore, the oil grades and oil change periods as specified on page 24 must strictly be observed.

2.2 Oil Viscosity

The viscosity of the oil being greatly influenced by the temperature, the choice of the viscosity grade (SAE-grade) should be governed by the ambient temperature at engine site (see diagram).

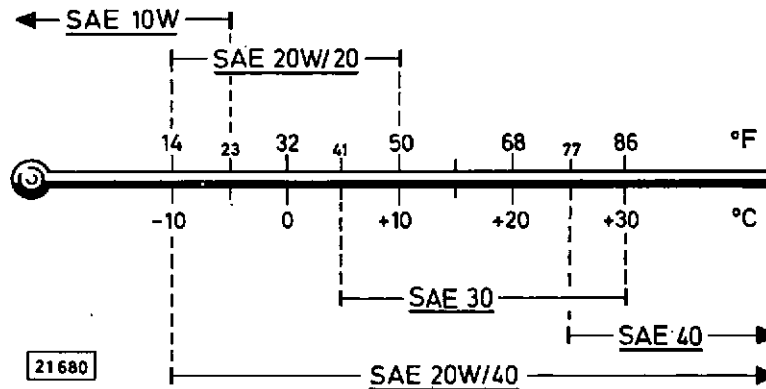

A too viscous oil causing starting difficulties, the choice of the viscosity grade during winter operation should be governed by the ambient temperature prevailing **at the time of starting the engine**. Oil changes as a function of temperatures can be avoided by using multi-grade oils which, however, should at least satisfy the requirements of high-quality HD-B oils, in conformity with MIL-L-46152 specification. Multi-grade oils, too, are subject to the oil change intervals recommended on page 24.

The required initial filling capacities are given under "Specification Data" on page 5.

3. Oil Bath Air Cleaner

The air cleaner must be filled with oil before starting up (see B 2 on page 20). To do this, fill in the same grade of motor oil as that used for the engine. Be sure not to fill dust trap 7 of precleaner 6, if fitted, with oil as it is exclusively meant for collecting dust.

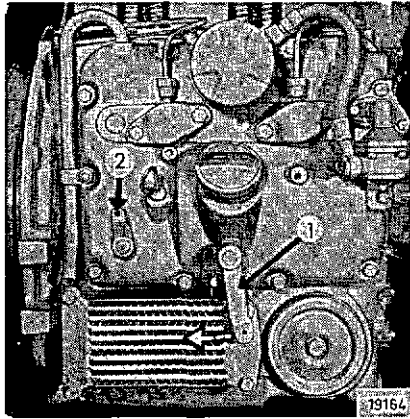

Fig. 3

Starting (Electrically) F2L 912 (Direct Injection)

1. Disengage clutch to disconnect engine from driven equipment.
2. Move speed control lever 1 (Fig. 3) to about quarter speed by hand or foot (arrowed direction).
3. Insert starter key 1 (Fig. 4), turn clockwise to detent and check that charging pilot lamp 2 and oil pressure lamp 3 light up. Push key in deepest position and turn farther clockwise against spring pressure; release key as engine starts firing.

If heater plug/starter switch 4 is provided:

First, insert switch box key 5 to stop, turn key of heater plug/starter switch 4 via position 1 to position 2. Release key as soon as engine fires. Key returns to neutral under spring load. For starting under winter conditions please refer to the instructions on page 13, section 3. Do not leave the starter motor running uninterrupted for more than 10 seconds. You save on your battery if an interval of about one minute is allowed between successive starting attempts.

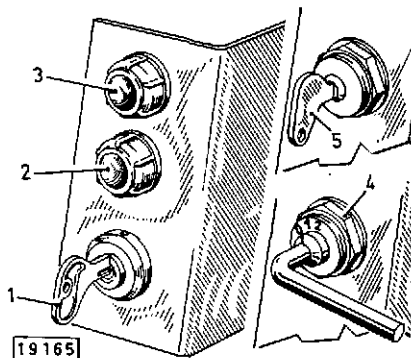

Fig. 4

4. Cut the speed back as soon as the engine is firing smoothly. The charging pilot lamp and oil pressure lamp should by now have gone out. A few minutes' running at moderate load and varying speed will bring the engine up to its normal working temperature. On engines driving electric generating sets warming up should be done at preset speed.

When an oil pressure gauge with red/green dial is fitted, the pointer must stand at green. When pointing to the red sector*, the engine must be shut down immediately and the cause be traced on the lines of the trouble chart. This also applies where a green warning lamp lights up.

In the window of the temperature indicator a green sector is displayed when the engine is at normal working temperature.

The appearance of a red sector with „Stop“ in this window means that the engine is overheated and must be shut down immediately. In this case the cause of the overheating must likewise be traced on the lines indicated in the trouble chart (see page 31 Section E).

* Transient pointing to red is admissible at low idling speed, provided the hand returns to the green sector as speed is increased.

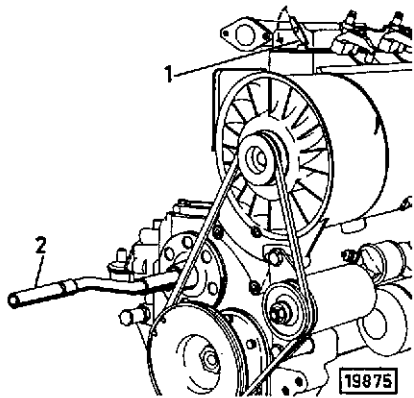

Fig. 5

Starting (by Hand) F2L 912 (Direct Injection)

1. Disengage clutch to isolate engine from driven equipment.
2. Set speed control lever 1 (Fig. 3) by hand or foot to about 1/4 speed position in the direction of the arrow.
3. Move decompression lever 1 (Fig. 5) in the direction of the arrow up to the stop.
4. Now turn starting handle 2 (Fig. 5) briskly until after about six turns the decompression is shut off automatically and the engine starts to fire.
5. As soon as the engine runs smoothly, cut back the speed. When a moderate load is applied and the speed is varied, the engine will warm up to its working temperature in a short time.
6. Keep an eye on the oil pressure gauge. The hand must point to the green sector. If the hand points to the red sector^{*)}, the low oil pressure must be remedied in accordance with the trouble chart.

The decompression device must not be worked when the engine is running. It is provided only on hand-started engines.

^{*)} Transient pointing to red is admissible at low idling speed, provided the hand returns to the green sector as speed is increased.

Stopping F2L 912 (Direct Injection)

Do not shut the engine down suddenly from full load running, but let it idle for a short time to allow for temperature balancing.

1. Set speed control lever 1 (Fig. 3) to low idling.
2. Operate stopping lever 2 (Fig. 3) on the injection pump until the engine comes to a stop, whereafter the charging pilot lamp 2 (Fig. 4) and oil pressure lamp 3 (Fig. 4) will light up again.
3. Turn starter key 1 anti-clockwise to first detent or, if a heater plug/starter switch 4 is provided, pull out switch box key 5; this will cause the charging pilot lamp 2 and the oil pressure lamp 3 to go out.

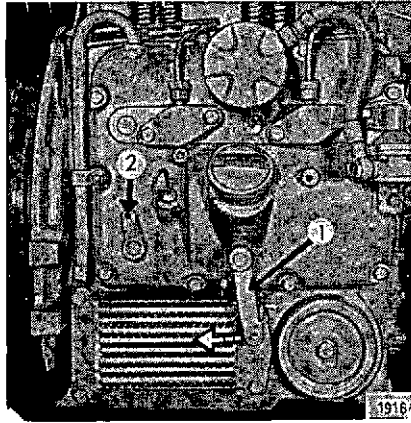

Fig. 6

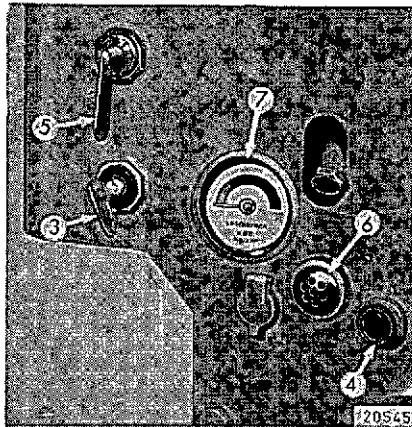

Fig. 7

Starting (electrically)

F2L 912 W (Two-stage Combustion)

1. Disengage clutch to isolate engine from driven equipment.
2. Set speed control lever 1 (Fig. 6) to about quarter speed by hand or foot in the arrowed direction.
3. Insert switch box key 3 (Fig. 7) and check that charging pilot lamp 4 lights up.
4. To preheat turn heater plug/starter key 5 to position 1. Preheat for about 30 to 60 seconds and in winter at low temperatures for approx. 1 to 2 minutes. Check that heater plug indicator 6 glows up slowly. Preheating is not required when the engine is still warm.
5. Turn heater plug/starter key 5 further to position 2. Release key as soon as engine starts firing. Do not operate the starter motor uninterruptedly for more than 10 seconds. The life of the battery and that of the starter motor will be prolonged if an interval of about 1 minute is allowed between successive starting attempts. Do not start as long as the engine is still running. For starting under winter conditions please refer to the instructions on page 12.
6. Cut the speed back as soon as the engine is firing smoothly. The charging pilot lamp 4 and heater plug indicator 6 should by now have gone out. A few minutes running at moderate load and varying speed will bring the engine up to its normal operating temperature.
7. Keep an eye on the oil pressure gauge 7. The pointer must stand at green. If it remains on the red sector* or if in case of an engine provided with an oil pressure warning lamp the latter lights up, the engine must be stopped immediately and the cause of the low oil pressure be traced on the lines of the trouble chart.

* Transient pointing to red is admissible at low idling speed, provided the pointer returns to the green sector as speed is increased.

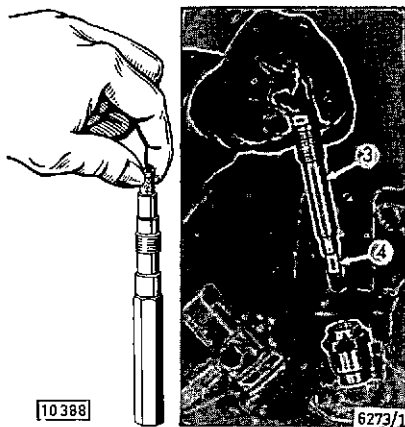

Fig 8

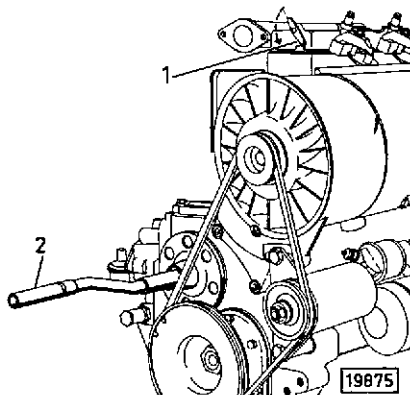

Fig 9

Starting (by Hand)

F2L 912 W (Two-stage Combustion)

1. Disengage clutch to isolate engine from driven equipment.
2. Move speed control lever 1 (Fig. 6) to about 1/4 speed position by hand or foot in arrowed direction.
3. Unscrew ignition paper holder 3 (Fig. 8) from cylinder head, insert the soft, non impregnated end of a dry self-igniting paper **firmly** in the holder and refit the latter. The ignition paper fits tight enough when the weight of the holder can be held by the salient paper end.

On no account should a detached ignition paper fall into the combustion chamber, thus causing the engine to get choked.

4. Move decompression lever 1 (Fig. 9) up to stop position in the arrowed direction.
5. Now turn starting handle 2 (Fig. 9) briskly until after about six turns the decompression is shut off automatically and the engine starts firing.
6. As soon as the engine runs smoothly, cut back the speed. A few minutes' running at moderate load and varying speed will bring the engine up to its normal operating temperature.
7. Keep an eye on the oil pressure gauge. The pointer must stand at green. If it remains on the red sector*, the cause of the low oil pressure must be traced on the lines of the trouble chart.

The decompression device must not be actuated when the engine is still running. It is provided only on hand-started engines.

* Transient pointing to red is admissible at low idling speed, provided the pointer returns to the green sector as speed is increased.

Stopping F2L 912 W (Two-stage Combustion)

Do not shut the engine down suddenly from full-load running, but let it idle for some time to allow for temperature balancing.

1. Set speed control lever 1 (Fig. 6) to low idling.
2. Operate stopping lever 2 on injection pump until the engine comes to a stop. In case of an electrically started version, the charging pilot lamp 4 (Fig. 7) and, where an oil pressure indicator lamp is provided, the latter will light up.
3. Pull out switch box key 3 (Fig. 7) whereupon the charging pilot lamp 4 and the oil pressure indicator lamp — if provided — will go out.

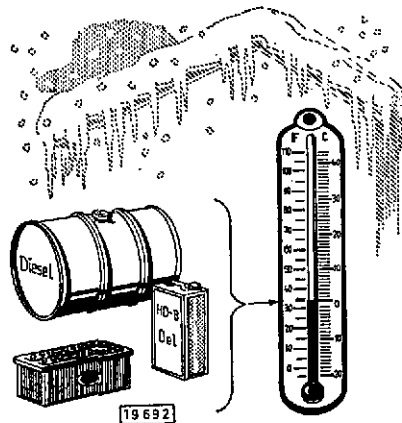

Fig. 10

Hints for Winter Operation

1. Use winter-grade motor oil

At low ambient temperatures, the motor oil is subjected to particularly adverse conditions. Therefore, high-grade HD-B or HD-C oils should be used (oil change intervals see on page 24).

To ensure satisfactory cold starting; the choice of the viscosity grade (SAE-grade) should be governed by the ambient temperature prevailing **at the time of starting** (viscosity specifications on page 7).

As to the oil change intervals, it should be borne in mind that operation in winter is to be considered as "heavy operating conditions", consequently resulting in shorter oil change intervals (see section B 5, page 24).

2. Use winter grade diesel fuel only during the cold season, because with ordinary fuel, paraffin deposits may form at low temperatures and clog the fuel filter. At excessively low temperatures, even winter grade fuel will tend to cloud. If only summer grade fuel is available, or if winter grade fuel is used at very low temperatures, we recommend the following values for the admixture of kerosene, tractor fuel, or standard gasoline, whereby the admixture of the latter is to be considered as a substitute which must not be used for more than one tank filling.

Ambient temperature	Summer diesel fuel %	Admixture %	Winter diesel fuel %	Admixture %
down to -10°C ($+14^{\circ}\text{F}$)	90	10	100	—
down to -14°C ($+7^{\circ}\text{F}$)	70	30	100	—
down to -20°C (-4°F)	50	50	80	20
down to -30°C (-22°F)	—	—	50	50

Here is a simple method for testing the suitability of diesel fuel at low temperatures: pour some diesel fuel into a small bottle and expose to the cold — any clouding would mean that the fuel can be used only in summer or in tempered rooms.

3. Cold Start F2L 912 (Direct Injection)

3.1. Without starting aid (down to -12°C) (10.4°F)

Since the engine works according to the direct injection principle, a cold start down to above-mentioned temperature can securely be performed without starting aid, provided that engine and battery are in good operating condition.

3.2. With preheating tube (down to -15°C) (5°F)

The heating tube, located at the suction end of the intake pipe, houses an electric heating coil for preheating the combustion air. In addition to lowering the starting temperature by 3°C (5.4°F), the preheating tube can also be employed to facilitate starting at temperatures which do not call for a starting aid — this helps to save your battery.

3.3. With start pilot (down to -18°C) (-0.4°F)

With the aid of the start pilot, highly ignitable fuel is sprayed into the intake pipe during starting. (See leaflet for start pilot Viso 2 and leaflet for start pilot Viso F 27.)

3.4. If starting with the start pilot is no more possible, the use of a preheating device is necessary. Connecting parts for preheating devices, however, are only provided on engines intended for operation in extremely cold areas.

3.5. Charging state of battery

Minimum starting temperatures as given under 3.1. and 3.3. suppose the battery to be in good charging condition; in this case, ambient battery temperatures are identical with minimum starting temperatures.

By warming the battery to approx. $+20^{\circ}\text{C}$ (68°F) (removing the battery after engine shut-down and storing it in a warm room) indicated minimum starting temperatures can be lowered by another $4-5^{\circ}\text{C}$ (7.5 to 9°F).

When refitting the battery, be sure that terminal connections make good contact (contact surfaces must be clean; tighten terminal clamping bolts without forcing them to prevent battery terminals from getting warped).

3.6. Starting procedure

3.6.1. With preheating tube

1. Disengage the clutch; 2. Move speed control to about quarter speed; 3. Insert switch-box key 5 (Fig. 4) to stop. Now turn heater plug/starter key 4 (Fig. 4) to position I and hold for approx. 1 minute (preheating). Then turn heater plug/starter key 4 to position II. As soon as engine commences firing, release heater plug/starter key (returns to O-position) or if engine failed starting, preheat again in position I. Never have the starter motor running uninterruptedly for more than 15 seconds. However, if sporadic firing occurs, the starter motor may be actuated up to 20–25 seconds. If engine fails starting, you save on your battery, if an interval of 2 minutes is allowed between successive starting attempts.

3.6.2. With Start Pilot

To aid starting procedure, actuate pump until engine fires regularly. Please refer to leaflet for start pilots Viso 2 and leaflet for Viso F 27.

4. Cold Start of F2L 912 W (Two-stage Combustion)

Starting limit temperature below -18°C (0.4°F)

Starting procedure as described on pages 10 and 11. If at low temperatures the engine runs untrue (misfirings) when being started, continue to preheat for 1 to 2 minutes with heater plug/starter key in position 1. In case of an electrically started engine ensure that the battery is in perfect condition. See section 3.5.

5. Once a week drain off the thick sludge from the fuel tank and fuel filter by removing the sludge drain plug. Also, clean lift pump strainer 4 (Fig. 18 on page 22).

6. The Grade of Oil in the Oil Bath Air Cleaner should suit the ambient temperature just like the engine oil.

7. Flywheel ring gear. If ambient temperature drops below -20°C (-4°F), lubricate ring gear from time to time through the pinion hole with low-temperature grease, e. g. Bosch FT 1 V 31 grease, in order to ensure full meshing of starter pinion. To do so it may be necessary to remove the starter motor.

Air-Venting the Fuel System

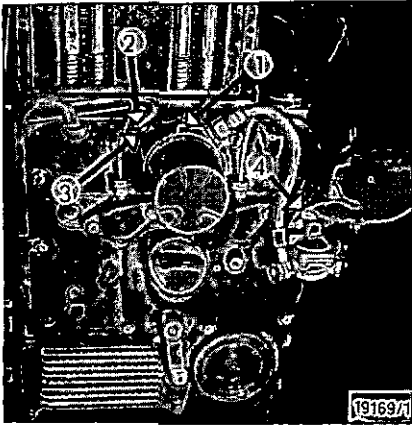

Fig. 11

Make sure that the tank is never run dry. The presence of air at any point in the fuel system — whether in the fuel filter or fuel piping — means that there is no fuel at that point. The air which has made its way into the fuel system prevents the proper flow of fuel to the injection pump so that the engine will either start with difficulty or not at all. Therefore, after the fuel filter has been renewed and following any work involving disconnection of fuel piping, it is essential to air-vent the fuel system.

To do this, release venting screw 1 (Fig. 11) and actuate priming lever 4 by applying thumb pressure in upward direction until fuel emerges free of bubbles at the released venting screw 1. Then retighten venting screw 1. Repeat this priming procedure — after having released banjo bolt 2 and reducing screw 3 — until fuel emerges free of bubbles at these screws, too. Retighten reducing screw 3 and banjo bolt 2.

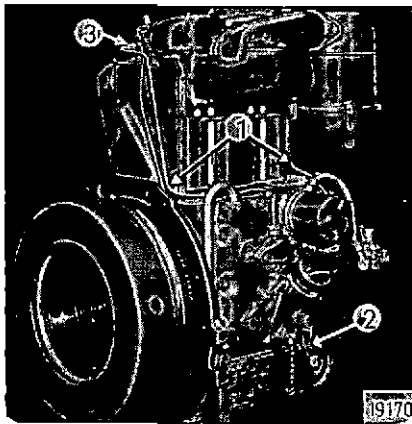





Fig. 12

When operated by hand, the lift pump will only work if the camshaft is in such position that the diaphragm of the lift pump is not lifted. When operating the prime lever, the distinctly perceivable "pressure point", i. e. the commencement of the lifting movement of the diaphragm has to occur in the first quarter of its total travel, if not turn engine a little over by hand.

If the injection lines 1 (Fig. 12) had been dismantled, they must also be re-primed. To do this, set speed control 2 to full load position and actuate starter motor until bubble-free fuel emerges at union nut 3 which had been released by 2 or 3 turns at either line end.

MAINTENANCE SCHEDULE for **DEUTZ** Diesel Engine F 2 L 912/W

Perform at following intervals	B = W =	Routine servicing Workshop maintenance	Details see page
Every  10 hours	B 1	Check oil level in engine	20
	B 2	Check air cleaner and clean (every 10 to 60 hours depending on dust in air)	20 21
Every  120 hours	B 3	Clean strainer of fuel lift pump	22
	B 4	Clean cooling fins	23
	B 5	Change oil in engine and clean lube oil filter . .	24
	B 6	Check battery electrolyte level	25
Every  240 hours	B 5	Change oil in engine and clean lube oil strainer .	24
	B 7	Check valve clearance (for the first time after 20 running hours)	25
	B 8	Check V-belt tension	26
Every 600 hours	W 1	Check injectors	27
	W 2	Check connections of intake and exhaust manifold .	27
	W 3	Check Dynamo	27
Every  1200 hours	W 4	Check 3-phase alternator	27
	W 5	Check starter motor	28
	B 9	Replace fuel filter cartridge	27

Our guarantee is invalidated, should, during the period covered by it, any adjustments or repairs be done without our approval.

The maintenance jobs duly completed can be recorded and certified in the schedule below.

Carry out

every 120 running hours maintenance jobs B 3 to B 6

every 240 running hours maintenance jobs B 3 to B 8

Completed Maintenance Jobs					
every		120	and	240	running hours
Hours	Date	Signature	Hours	Date	Signature
* 20			—		
* 60/80			—		
120			240		
360			480		
600			720		
840			960		
1080			1200		
1320			1440		
1560			1680		
1800			1920		
2040			2160		
2280			2400		
2520			2640		
2760			2880		
3000			3120		
3240			3360		
3480			3600		
3720			3840		
3960			4080		
4200			4320		
4440			4560		
4680			4800		
4920			5040		
5160			5280		
5400			5520		
5640			5760		
5880			6000		

* See notes at bottom of page 19

The maintenance jobs duly completed can be recorded and certified in the schedule below.

Carry out

every 120 running hours maintenance jobs B 3 to B 6

every 240 running hours maintenance jobs B 3 to B 8

Completed Maintenance Jobs						
		every	<div style="border: 1px solid black; display: inline-block; padding: 2px 10px;">120</div>	and	<div style="border: 1px solid black; display: inline-block; padding: 2px 10px; transform: rotate(45deg); transform-origin: center;">240</div>	running hours
Hours	Date	Signature	Hours	Date	Signature	
6120			6240			
6360			6480			
6600			6720			
6840			6960			
7080			7200			
7320			7440			
7560			7680			
7800			7920			
8040			8160			
8280			8400			
8520			8640			
8760			8880			
9000			9120			
9240			9360			
9480			9600			
9720			9840			
9960			10080			
10200			10320			
10440			10560			
10680			10800			
10920			11040			
11160			11280			
11400			11520			
11640			11760			
11880			12000			

The maintenance jobs duly completed can be recorded and certified in the schedule below.
 Carry out
 every 600 running hours maintenance jobs W 1 to W 3
 every 1200 running hours maintenance jobs W 1 to W 5 and B 9

Completed Maintenance Jobs					
		every 600 and  running hours			
Hours	Date	Signature	Hours	Date	Signature
600			1200		
1800			2400		
3000			3600		
4200			4800		
5400			6000		
6600			7200		
7800			8400		
9000			9600		
10200			10800		
11400			12000		

Ever-ready availability

and a long working life will be obtained from the engine if it is given proper maintenance at the recommended intervals. During this work always use the specified lubricants and detergents. The 9 maintenance jobs (B 1) to (B 9) affecting the relatively few lubricating and maintenance points are not only clearly set out in the Maintenance Schedule but are also explained in detail on the following pages. Please read them carefully, too.

Oil Changes for New or Overhauled Engines

Routine change every	1st change after	2nd change after a further	3rd change after a further	further changes every
100-120 hours	20 hours	40 hours	—	100-120 hours
200-240 hours	20 hours	60 hours	120 hours	200-240 hours

When switching over to a higher-grade oil, it is advisable to perform the first oil change in any case already at the end of 20 running hours. At the same time, the filter should be cleaned or replaced as required.

Note: When performing the second oil change, be sure to retighten any new V-belts. Retighten fastening bolts of intake and exhaust manifolds at cylinder heads as well as bolts of oil sump and engine mounting.

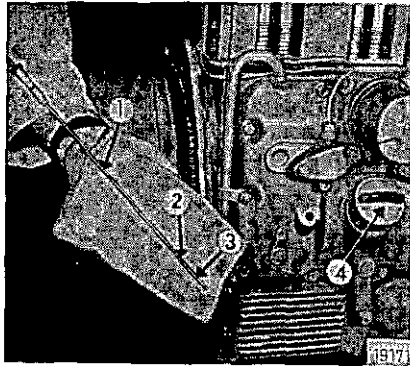

Fig. 13

Notes on Maintenance Schedule

B1 Check Engine Oil Level

Normally, new engines have a higher oil consumption which necessitates the oil level being checked twice a day during the running-in period (the first 200 operating hours). Thereafter, one oil level check per day will be sufficient. Check oil level with the engine stopped and standing in the horizontal. Pull out dipstick 1 (Fig. 13), wipe it with a non-fraying rag, push it in as far as it will go and then withdraw it again. The dipstick should then have a coating of oil extending to the upper mark 2. If the oil level is only up to the lower mark 3, top up with oil immediately, through filler 4, otherwise serious damage might be done to the engine. (Seizure of the pistons and bearings.)

B2 Checking and Cleaning Air Cleaners

Dust in the combustion air can cause premature wear of the engine. Maintenance of the air cleaners, therefore, is essential to ensure long life. It is also necessary to check regularly the connecting points of the intake manifold.

Oil Bath Air Cleaner

every 10 to 60 running hours, depending on dust conditions. But the engine should have been stopped for at least an hour, so that the oil has had time to drip from the air cleaner unit 1 (Fig. 14) into the bowl 2. First release clips 3 to enable bowl 2 to be removed. The bottom part 4 of the air cleaner can be easily dismantled by giving it a slight tap on the side with the hand. Pour out the old thick and sludgy oil and clean with diesel fuel the dismantled components 2 and 4. After the fuel has completely dripped out of the filter element 4, the bowl should be filled with fresh motor oil up to the oil level mark 5 (bead) and, together with the clean filter 4, reassembled in position. Check that joint between air cleaner and intake pipe is tight.

Once a year, if the ambient air is moderately dust-laden, dismantle the entire air cleaner and service the top fixture containing metal wool by dipping several times in diesel fuel. In case of extreme dust conditions, this procedure has to be carried out twice a year.

Do not damage the rubber sealing ring on the bottom part of the air cleaner.

When very dusty conditions are experienced, a cyclone type pre-cleaner 6 is often fitted, the dust outlet 7 of which must never be clogged.

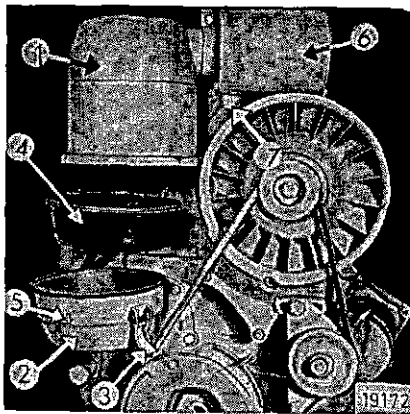

Fig. 14

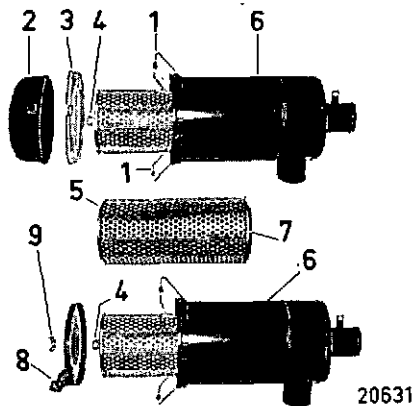

Fig. 15

Dry-type Air Cleaner

The life of the expendable paper cartridge in dry-type air cleaners is influenced by the dust collector being emptied regularly and in good time. Failing this, the cartridge will soon be clogged by large quantities of dust. Therefore, the dust accumulating must never fill the collector to more than half. In dusty conditions, this means that the collector may have to be emptied daily. If a special dust ejector 8 is provided, it is only necessary to clear the discharge slot from time to time.

1. Emptying the Dust Collector

Stop engine. Release clips 1 (Fig. 15) and remove dust collector 2 along with cover 3. Take down cover and empty collector. Refit assembly, seeing to it that recess on cover mates with lug on collector (see arrows in Fig. 16). When cleaner is installed in horizontal position, check that "Top" mark is up.

2. Servicing the Cartridge

Where a vacuum-type contamination indicator (Fig. 17) is fitted and keeps displaying a red warning signal when the engine is stopped, or where a yellow warning light goes on with the engine running, the cartridge is due for servicing. (Also indicated by smoking exhaust and decreasing engine output.) It is not advisable to service the cartridge more frequently as this may affect seal 7 (Fig. 15) between cartridge 5 and housing 6.

Replace cartridge not later than at the end of 12 months.

Proceed by taking down dust collector 2 (Fig. 15) as under 1. (Where a dust ejector 8 is provided, unscrew wing nut 9 and remove cover.) Next unscrew hex. nut 4, take out cartridge and replace or clean as below. After 4 or 5 times of intensive cleaning, or where the cartridge is contaminated by soot, replacement is indispensable.

Make sure that only genuine cartridges are used as supplied by the air cleaner manufacturer. Cartridges of other make usually do not fit and are a hazard to the engine.

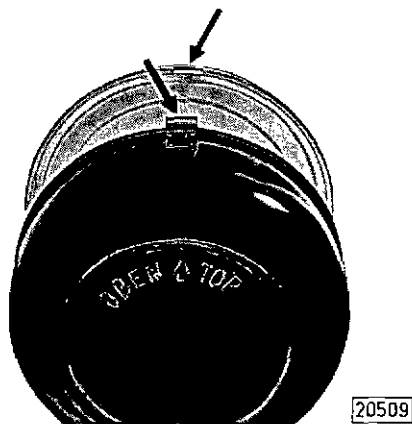

Fig. 16

Cleaning by dry means

- a) provisional: Tap cartridge 5 with its front end gently several times, i. g. against the palm of your hand or on a soft surface, to shake off the dust. Take care not to damage the front end of the cartridge.
- b) intensive: Apply air blast of max. 5 atm. diagonally inside and out until no more dust is coming forth.

Do not blow out housing 6.

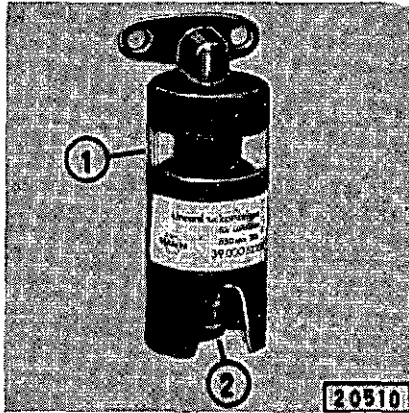

Fig. 17

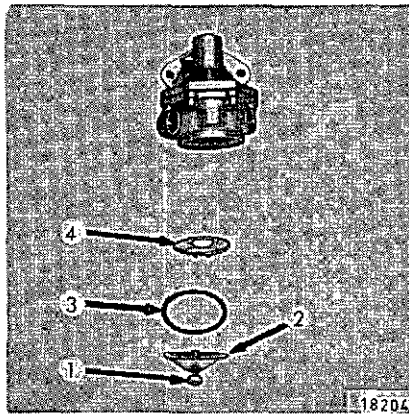

Fig. 18

Washing the cartridge:

Wash the cartridge 5 in lukewarm water containing a mild commercial detergent by shuttling it in the water for some time. Then rinse it thoroughly in fresh water, shake off the water and let it **dry well** (in no event use benzine or hot liquids).

3. Checking:

Prior to reassembly, introduce a lighted bulb into filter cartridge 5 to see whether it suffered damage (damaged cartridges must definitely be renewed). Also make sure that seal 7 is not defective. If a contamination indicator with visual signal is fitted (Fig. 17), push button 2; this causes the red signal to disappear from the window.



Cleaning Strainer of Fuel Lift Pump

Every 120 running hours. Remove consecutively screw 1, cover 2, gasket 3 and strainer 4 (Fig. 18). Clean strainer in fuel. When reassembling, ensure perfect tightness.

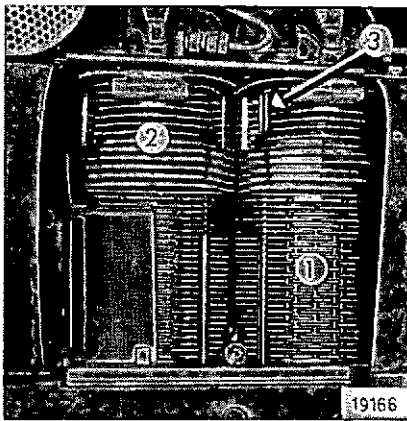

Fig. 19

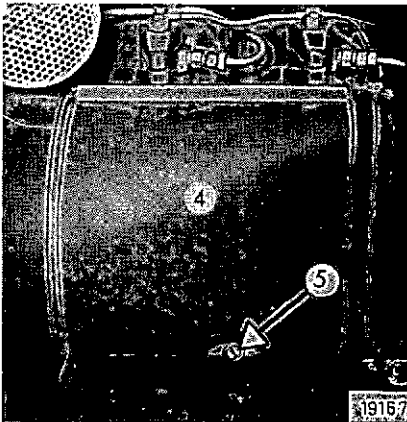

Fig. 20

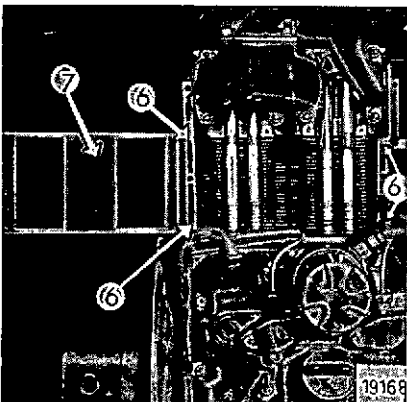

Fig. 21

B4 **Cleaning the Cooling Fins every 1200 running hours,**

more frequently in case of very dusty operating conditions.

Dust accumulated on the cylinder cooling fins 1 (Fig. 19) and cylinder heads 2, especially in the presence of fuel and lubricating oil, reduces cooling efficiency. Special care should be given to cleaning the vertical cylinder head fins 3.

Proceed by detaching air cowling 4 (Fig. 20) after removing screw 5. Following this detach baffle 7 on the exhaust side after loosening hex bolts 6 (Fig. 21).

For cleaning the fins of the lube oil cooler, remove the four fastening screws and detach oil cooler with care as the oil in the pipes will run out.

When refitting, make sure that gasket is squarely seated; replenish lost oil.

We recommend cleaning the cooling fins by dry means, e. g. a wire and, if possible, compressed air. It is advisable to start blowing through the cooling fins from the exhaust side. If diesel fuel or a cold cleansing agent is used for cleaning, it is important, after allowing for an adequate soaking-in period, to wash the engine parts with a powerful water jet.

Following this, the engine should be run until warm so that any water left behind will be evaporated before rust can form.

If a steam jet is available, this method of cleaning is preferable to any other.

Carry out the oil changes at regular intervals and strictly adhere to the prescriptions of the table below. (As to the viscosity grades see sect. 2.2 on page 7.)

Operating conditions	Sulphur content of fuel (% by weight)	Oil change intervals (hours) according to specified oil grades		
		HD-S 1	HD-B	HD-C
Normal	up to 0.5	100-120	200-240	200-240
Normal	above 0.5		100-120	200-240
Heavy **	up to 0.5			100-120
Heavy **	above 0.5			100-120

In the case of engines on temporary duty only, e.g. standby power generation, carry out oil changes not later than at the end of six months.

Oil Grades:

HD-S 1 ***

oils are motor oils conforming to MIL-L-2104 A, Supplement 1 or DEF 2101 D.

HD-B ***

oils are high-blended motor oils corresponding to specification MIL-L-2104 B as well as to specification MIL-L-2104 A, Supplement 1. Oils complying with the new specification MIL-L-46152 and with the former specification MIL-L-45199 B or with the specification S 3 are also in conformity with the required oil grades

HD-C ***

oils are motor oils corresponding to the new specification MIL-L-2104 C.

Regarding initial oil change for new or overhauled engines, please see page 19.

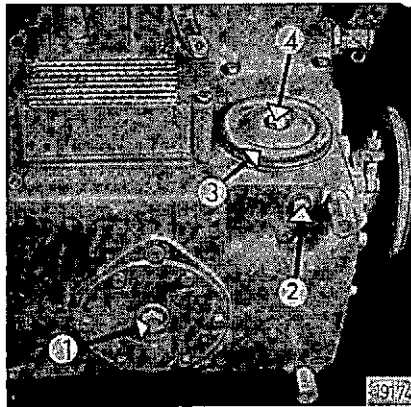

Fig. 22

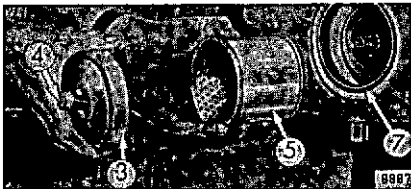

Fig. 23

Carry out oil changes only when the engine is warm as the oil drains off better when warm. Remove for this plugs 1 and 2 (Fig. 22). Next remove screw 4 to detach filter bowl 3 and wash strainer 5 (Fig. 23) in clean diesel fuel.

When re-assembling be sure the drain plugs and the oil strainer seal 7 are tight. Fill in fresh oil through the filler neck only to top dipstick mark 2 (Fig. 13). Check the oil level again after a short trial run. During the trial run, the oil pressure indicator should be watched and proper tightness secured.

If you expect the filter to function properly – service it properly!

Oil Change Quantity: approx. 4.5 ltrs.

* The lube oil filter (Fig. 23) consists of strainer 5, through which the oil, coming from the oil pump, is forced and deposits its impurities on the jacket surface. The filtered oil reaches the lubrication points.

** Heavy operating conditions are understood to be: long idling periods, prolonged temperatures above 30° C, operation in winter.

*** For examples see on pages 31, 32.

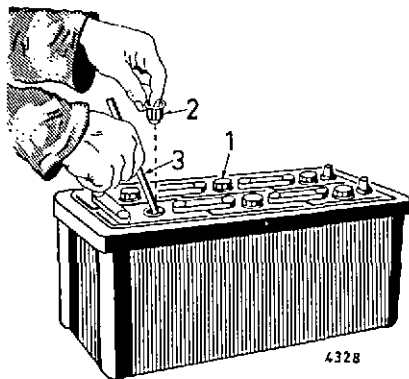

Fig. 24

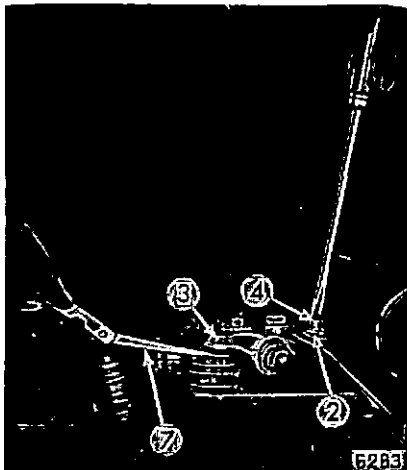

Fig. 25

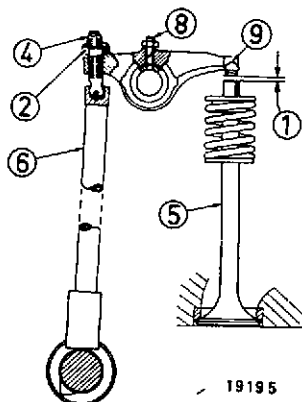

Fig. 26

B6 Check Electrolyte in Battery

every 120 running hours, at least every four weeks. For this purpose check the level in the individual cells after unscrewing the screw plug 1 (Fig. 24). In some cases electrolyte level testers 2 will be fitted. The level should be sufficiently high to wet the bottom of the testers.

If these testers are not provided, a clean wooden stick 3 should be inserted into each cell until it touches the top of the lead plate. After it has been withdrawn, it should be wet over a distance of 10 to 15 mm ($\frac{3}{8}$ to $\frac{5}{8}$ "'). If the level of the electrolyte is low, distilled water only should be used for topping up. Never place tools on the battery as they might cause short-circuit. The battery should undergo a workshop test from time to time for checking its condition.

For use in winter see page 13.

B7 Check Valve Clearance *)

at 1st and 2nd oil changes and later under normal working conditions:

every 240 to 360 running hours:

Where, however, working conditions are severe, e. g.

heavy load variation,
frequent starting attempts,
very high dust content of air,

the checking intervals should be shorter and the maximum valve clearance be chosen.

Check clearance with engine **c o l d** by means of a feeler gauge 7 (Fig. 25) of 0.15 mm (0.006 in.) thickness. To do this, turn crankshaft until the piston of the cylinder in question reaches the compression dead center, i. e. after overlapping of both valves (exhaust valve about to close, inlet valve about to open), go on turning the crankshaft through 360°, corresponding to a complete revolution.

Valve clearance 1 is correct when the feeler gauge can be inserted with a slight drag in the gap 1 between rocker arm 3 and valve 5 (Fig. 26), both intake and exhaust. If not, loosen lock nut 2 of adjusting screw 4 by one or two turns and adjust by means of a screw driver in such a way that the feeler gauge can easily be drawn out upon retightening lock nut 2.

The center punch mark located above the chamfer on the oil nozzle 8 (Fig. 26) must always point towards rocker arm 9 so as to ensure lubrication even at low idling.

On hand-startable engines, after having tightened both screws fastening the cylinder head covers, check that the decompression shafts can be turned easily in a small angle of about 10° .

* The valve clearance is the requisite gap 1 between the rocker arms 9 and valves 5 (Fig. 26). Good engine performance and power output depend on its correct setting which can be done by a skilled mechanic according to the above instructions. If not, it should be carried out by a specialist.

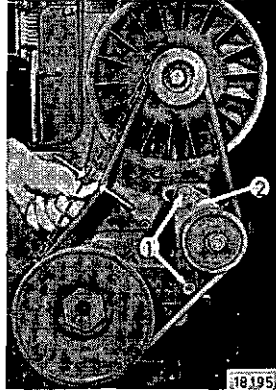

Fig. 27



Check V-belt Tension of Generator and Blower

At intervals of **240 running hours** check that V-belt, when pressed half-way with the thumb (Fig. 27) does not deflect by more than 15–20 mm ($\frac{5}{8}$ – $\frac{3}{4}$ in.). For re-tightening the belt loosen the two hex. bolts 1 and swing generator 2 outwards until belt tension is correct. Re-tighten hex. bolts 1 securely.

With a two-belt drive always replace **both** belts by a new set, even if only **one** belt is broken or worn. The length of the two new V-belts must not differ by more than 0.15 %.

New generator V-belts must be well re-tightened after a short initial operating period and not later than after 40 hours.

If a mechanical V-belt safety device (Fig. 28) is provided, pulley 1 effects engine shut down in case of V-belt rupture.

Watch for proper V-belt tension, otherwise deflection of pulley 1 will actuate shut-down rod 2. When changing motor oil, lubricate pin 3 with one drop of oil.

Shut-down rod 2 must be so adjusted that shut-down lever 4 clears its final stop by an angle of approx. 3° .

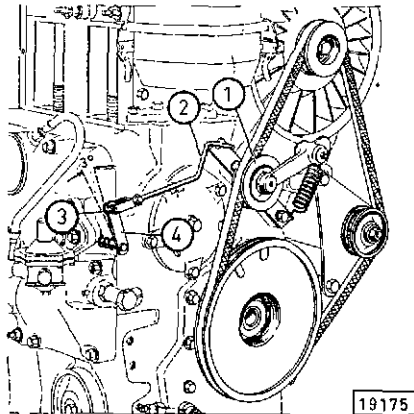

Fig. 28

Workshop Maintenance

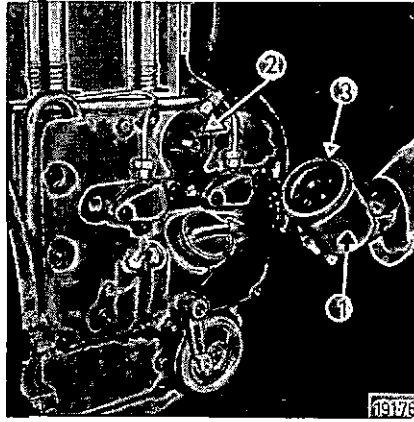

Fig. 29

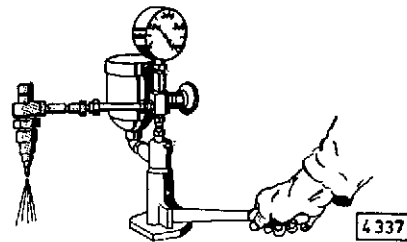

Fig. 30

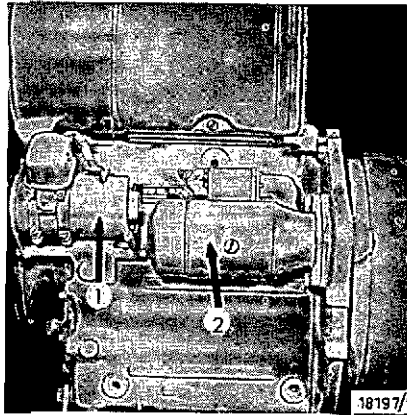

Fig. 31

B9

Renew Fuel Filter Cartridge *)

every 1200 running hours or when the engine's output falls off. To do this, detach filter bowl 1 (Fig. 29) with integral filter carefully as the fuel will run out. See that seat 2 is perfectly clean.

Before fitting the new filter, slightly oil rubber seal 3 and screw in the filter until seal is squarely seated. Then give assembly a final half turn to have it tight.

Air-venting of the filter according to page 15. After restarting the engine, check that the filter assembly is perfectly tight.

Order-No. of the expendable fuel filter cartridge:
116 1341 EE 8941-17

*) The fuel filter has an essential function since injection pump and nozzles are high-precision items which can properly operate only on perfectly clean fuel.

W 1 Injectors

Every 600 running hours the injectors should be taken down and properly cleaned in diesel fuel. Following this they should be tested to see that they give the specified injection pressure for DEUTZ engines, i. e. for:

F2L 912 D 175 kp/cm²

F2L 912 W 125 kp/cm².

This test is made with the aid of a nozzle tester (Fig. 30).

W 2 Intake and Exhaust Manifolds

Every 600 running hours, check connections at cylinder heads for leaks and tighten up if necessary.

W 3 Checking the Dynamo

Every 600 running hours it is advisable to have the generator 1 (Fig. 31) checked in a specialized workshop.

W 4 Checking the Alternator

It is recommended to have the alternator checked every 1,200 running hours in a specialized workshop.

In contrast to the direct current generator, the alternator delivers already at idling speed of the engine and thus ensures always a fully charged battery.

To keep the three-phase current system in good working order, the following instructions should be carefully observed:

1. When the engine is **running**, never disconnect the leads between battery – alternator – tension regulator. Where it is necessary, however, to operate the engine without battery, disconnect alternator from tension regulator prior to starting.
2. Do not confuse the battery terminals.
3. Renew immediately defective charging indicator lamp.
4. Cover generator and tension regulator when cleaning the engine.
5. In case of an alternator never make an earth connection by touching a solid body with a cable – contrary to a direct current system where such a testing method is usual – in order to ascertain whether a line is live.
6. In case of electric welding, connect the earth terminal of the welding apparatus direct to the piece to be welded.

W 5 Checking the Starter Motor

Every 1200 running hours, the starter motor 2 (Fig. 31) should be checked if frequently used.

Engine Preservation

If your engine is to be shut down for a major period (e. g. over the winter), we recommend the following preservative measures against rust formation.

1. Clean the outside of the engine with diesel fuel or benzine.
2. Drain the engine oil in hot condition and fill in corrosion inhibitor oil *).
3. Pour the oil out of the air cleaner bowl, clean bowl and fill in inhibitor.
4. *Drain fuel from tank, mix well with 10 % inhibitor and fill back into tank. Instead of adding inhibitor oil to the fuel, the tank can be filled up with injection pump testing oil having corrosion inhibiting properties (e. g. Calibration Fluid B).*
5. Run engine for about 10 minutes, so that pipes, filter, pump and nozzles are filled with the preservative mixture and the new motor oil is distributed to all parts.
6. After this run, detach the rocker chamber covers and spray the rocker chambers with a mixture of diesel fuel and 10 % anti-corrosive or injection pump testing oil having corrosion inhibiting properties. After this, refit the covers.
7. Now turn the engine over several times **without firing** in order to spray the mixture into the combustion chambers.
8. Detach V-belts and spray the pulley grooves with corrosion inhibitor. Remove inhibitor before re-using the engine.
9. Tightly close openings of air cleaner intake and exhaust pipe.

These measures will give about 6 to 12 months protection, depending on weather effects. *Before putting the engine back to use, replace the preserving oil by fresh motor oil. Where only temporary operation for not more than 10 hours and only at partial load is envisaged, the preserving oil may be retained.*

*) Shell-Ensis 20 or equivalent

Troubles – Their Causes and Remedies

Troubles are usually attributable to incorrect operation, lubrication or maintenance of the engine. Should you therefore experience trouble re-read carefully the few sections on pages 7 to 27 dealing with correct operation and maintenance. If you are unable to identify the cause of the trouble or cannot remedy it yourself, your best plan is to contact your DEUTZ dealer.

Trouble	No.	Possible cause	Remedy	Details on page
A Engine fails to start	1	Fuel tank empty	Fill up tank and vent	15
	2	Shut-off valve closed	Open shut-off valve and element, vent	15
	3	Fuel filter blocked, in winter through clouding	Renew filter use winter grade fuel	27 12
	4	Fuel lines leaky	Check all fuel lines for tightness and tighten unions	
	5	Charging indicator lamp does not light up inspite of bulb not being defective	Push home the switch key, tighten battery terminals, check wiring connections	8
	6	Heater plug indicator does not light up inspite of fully charged battery. On F 2 L 912 W only	Tighten battery terminals, check or replace coil in heater plug indicator	10
B Engine difficult to start	7	Battery low, battery terminals loose or oxidized causing starting motor to run slowly	Have battery tested, clean terminals, tighten and coat with acid-free grease	25
	8	In winter especially, grade of motor oil used is too viscous	Crank engine smartly by hand.	14
			Use a grade of motor oil to suit the temperature conditions	12
9	Inadequate fuel supply, fuel piping clogged in winter by paraffin deposits	Replace fuel filter, air-vent system, clean lift pump strainer, check fuel line connections for tightness and tighten unions. At low temperatures, use winter-grade fuel	27 15 22 12	

Trouble	No.	Possible cause	Remedy	Details on page
C Engine runs unsteadily and power output is low	10	Inadequate fuel supply	Replace fuel filter, air-vent system, clean lift pump strainer, tighten unions	27 15 22
	11	Valve clearance out of adjustment, valve spring broken	Readjust valve clearances. Have valve spring renewed	25 35
	12	Nozzle needles stick	Have them checked by a mechanic	28
D Dense exhaust	13	Level of motor oil too high	Drain off to upper mark on dipstick	20
	14	Level of oil in oil bath air cleaner too high	Pour off oil to reduce level to the mark	20
	15	Inefficient compression due to seized or broken compression rings, or incorrect valve clearances	Have compression rings and piston checked by a mechanic Readjust valve clearances	25
E Engine overheats	16	Cooling fins on cylinders and cylinder heads very dirty	Clean cooling fins, vertical ones on cylinder head in particular	23
	17	Injectors defective	Have them checked by a mechanic	28
	18	Injection pump delivery out of adjustment	Have it readjusted by a mechanic	
	19	Blocked blower air intake	Clear air intake	26
	20	Cooling blower V-belt broken	Replace V-belt	34
F Engine oil pressure too low	21	Leaks in lubrication system	Stop engine immediately Check unions on lubricating pump, oil pipe, oil filter and oil pressure gauge for tightness and tighten screw. Otherwise call in a mechanic	
G Charging indicator lamp lights up when engine is running	22	Generator speed too low	Check V-belt tension	26
	23	Generator not charging battery because either the generator or regulator/cut-out is defective	Have it checked by a mechanic	

List of Recommended Lube Oils

(Effective summer 1974, not exclusive *)

According to the suppliers, the brands listed below are of **HD-S 1** quality as described under section B 5 on page 24.

Oil Company	Brand of Oil
ARAL	ARAL AUTORAL
BP	BP DIESEL MOTOROIL HD, BP ENERGOL IC-D, BP ENERGOL IC-M
CASTROL	CASTROL HD, CASTROL/DEUSOL CRI
DEUTZER OEL-GES.	DEUTZ OIL SGHD
ESSO	ESSO ESTOR HD, ESSOFLEET HD
FINA	FINA SOLNA HD S 1
MOBIL	DELVAC 1130, MOBILGARD 312
RHEIN. MOTOR-OEL	RMV-HD-MOTOR OIL EXTRA SPECIAL RMV High-quality Motor Oil 1318 H
TEXACO	TEXACO GARANT HD
VEEDOL	VEEDOL MOTOR OIL CADEL HD M
WENZEL & WEIDMANN	ECUBSOL-MOTOR OIL EXTRA HD

According to the suppliers, the brands listed below are of **HD-B** quality as described under section B 5 on page 24.

Oil Company	Brand of Oil
ARAL	ARAL SUPER, ARAL KOWAL, ARAL SUPER KOWAL, ARAL SPECIAL, ARAL MOTORAL
BP	BP VANELLUS-T, BP VANELLUS M, BP ENERGOL HD, BP ENERGOL DS-B, BP SUPER VISCOSTATIC
CASTROL	CASTROL/DEUSOL CRB
CHEVRON	CHEVRON DELO SPECIAL MOTOR OIL, DELO 200 MOTOR OIL, DELO 300 MOTOR OIL
DEUTZER OEL-GES.	DEUTZ OIL HD SUPER DB, SGHD-B/2X
ESSO	ESSOLUBE SDX, ESSO ESTOR SDX, ESSOLUBE HDX, ESSO MOTOR OIL
FINA	FINA DELTA PLUS MOTOR OIL, PURFINA MOTOR OIL or FINA DELTA MOTOR OIL, FINA SOLNA S 3
FUCHS	RENOLIN HD, PENA PURA HD, PENA PURA HD SUPER, PENA PURA LD EXTRA, PENA PURA HD SUPERIOR, PENA PURA HD SUPER N
MOBIL	DELVAC 1130, DELVAC 1230, MOBILGARD 312
RHEIN. MOTOR-OEL	RMV-HD EMBLEM, RMV-HD EMBLEM DB, RMV-RHEMOTOL HD S 3
SHELL	SHELL ROTELLA SX, SHELL ROTELLA TX
TEXACO	URSA OIL ED, ULTRA MOTOROIL, ULTRA ALL TEMP, URSA OIL S 3, URSA OIL LA 3
VALVOLINE	VALVOLINE SUPER ALL CLIMATE, RITZOL SUPER HDX, LOROCO HD (DBM), VALVOLINE HD SUPER, HPO D.B.
VEEDOL	VEEDOL MOTOR OIL CADEL HD 900, VEEDOL SUPER 10/40, VEEDOL SUPER 20/50, VEEDOL MOTOR OIL CADEL HD S 3
WENZEL & WEIDMANN	ECUBSOL MOTOR OIL EXTRA HD, ECUBSOL SUPER OIL HD

According to the suppliers, the brands listed below are of **HD-C** quality as described under section B 5 on page 24.

<i>Oil Company</i>	<i>Brand of Oil</i>
ARAL	ARAL TURBORAL
BP	BP VANELLUS C 3, BP ENERGOL DS 3
CASTROL	CASTROL/DEUSOL CRD, CASTROL/DEUSOL CRF
CHEVRON	DELO 400 MOTOR OIL
DEUTZER OEL-GES.	DEUTZ OIL SGHD-G
ESSO	ESSOLUBE D-3, ESSOLUBE D-3 HP, ESSO ESTOR D 3
FINA	FINA KAPPA MOTOR OIL
FUCHS	PENA PURA UNIVERSAL HD
MOBIL	DELVAC 1330
SHELL	SHELL MYRINA, SHELL RIMULA CT
TEXACO	TEXACO URSA OIL LA 3
VALVOLINE	TOPFLITE CS-3, RITZOL HD C-3
VEEDOL	VEEDOL ADELBUS HD-C
WENZEL & WEIDMANN	ECUBSOL SUPREMA C/S 3 HD

* The above oil brands are quoted as examples of oils meeting our quality requirements. Other oil brands may also be used, of course, provided they correspond in quality to these specified.

Hints for the Specialist Tightening Screwed Joints

The Workshop Manual dealing with the subject engine of this booklet bears the number 291 1841 and can be ordered with our central spare parts department.

The following information is intended in particular for mechanics having to carry out repairs on these engines, but who do not belong to the DEUTZ organisation.

To prevent faulty assembly, the following notes include instructions on the tightening of the cylinder head bolts, because the procedure differs from that normally employed. The final tightening angle is especially important, and for this reason Fig. 32 indicates how the various angles can be readily obtained by comparison with a clock face. To obtain the desired angle all that has to be done is for the tommy bar on the spanner to be turned through the same angle as that formed by the hour and minute hands of the clock. The 60° angle of a hex. bolt head may also be a guide.

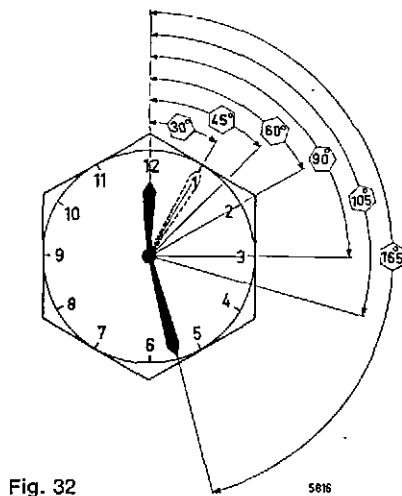

Fig. 32

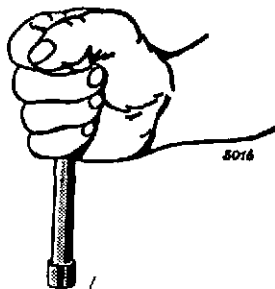

Fig. 33

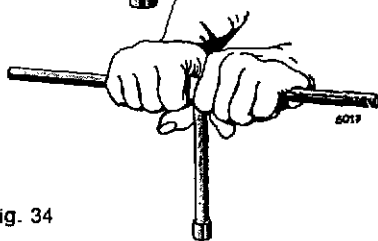

Fig. 34

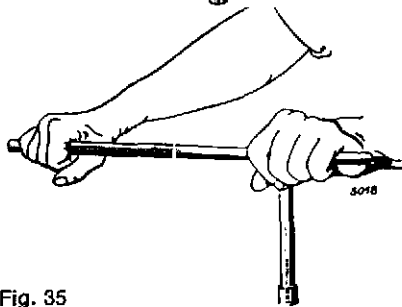

Fig. 35

1. **Wet threads and seatings with motor oil before fitting.**
2. **Screw the bolts in (Fig. 33)** until they are squarely seated, using a socket spanner without tommy bar or, in the absence of a socket spanner, a box or open-end spanner without making use of the leverage.
3. **Preload the bolts (Fig. 34)** by holding the tommy bar in such a manner that both hands are in contact with the spanner. When using a box or open-end spanner, the tip of your straight thumb of the hand holding the spanner must touch the head of the bolt. Preload bolts hand-tight, i. e. apply wrist force only (see adjoining table).
4. **Tighten the bolts (Fig. 35)** according to the Table on page 34, if necessary in stages, attaining the tightening angles specified.

Bolt Tightening Table

Fastening bolts/nuts	Designation	Pre-loading mkp	Tightening				Notes
			1st stage	2nd stage	3rd stage	Total	
Cylinder head	210 1681	3	45°	45°	45°	135°	
Connecting rod	M 12×1,5×55	3	60°	30°	—	90°	
Bearing cap	M 14×110	3	60°	45°	—	105°	
Rocker arm bracket	M 8×55	—	—	—	—	—	2.8 mkg
Balance weight	M 12×70	3	30°	30°	—	60°	
Flywheel nut	2116	5	90°	90°	—	180°	
Injector	M 10	—	Tightening torque 2.5 mkp				Only for F2L 912 D
V-belt pulley	M 35×1.5	5	60°	—	—	60°	
Cooling blower	M 12×140	3	60°	30°	—	90°	
Adapter housing	216 4062	3	90°	90°	60°	240°	

When replacing main and big-end bearings or after piston seizures, be sure to replace the bearing bolts, too.

Hints on Installing the Engine

Your plant or equipment will give trouble-free performance with the engine we have supplied if you attend to the following points:

Make quite sure that there is no possibility of the hot air discharged from the engine being re-circulated through it. If the air at the cooling blower intake is hot the engine will overheat; if the air at the air cleaner is hot the engine will develop less power. Prevent the re-circulation of hot air by providing means for the free escape of the air discharged from the engine. We suggest that you get in touch with us if you intend to provide a hot air offtake, as we are able to supply suitable fittings and components for this purpose. The air for cooling the engine and for combustion should be taken from a point where there is minimum of dirt and dust. We shall be glad to advise you on this problem, too.

Before you install your engine, do not fail to consult in good time one of our installation specialists. He will gladly pay you a visit to help you to solve your particular problems.

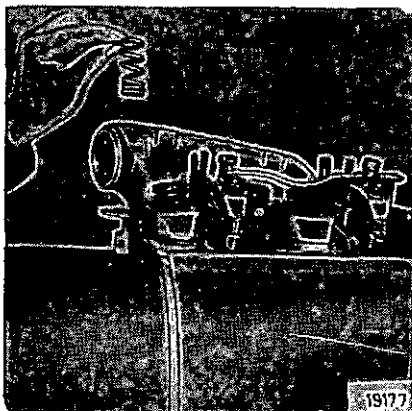

Fig. 36

When fitting a valve spring,
be sure that the more closely wound end of the spring is at the bottom (Fig. 36).

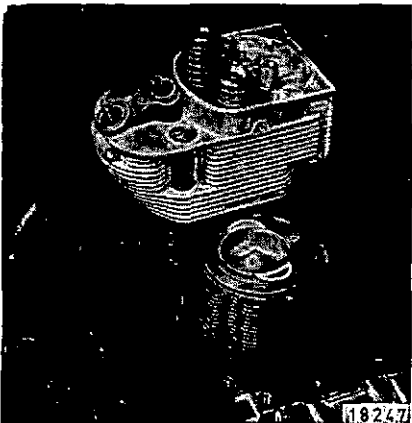

Fig. 37 (F2L 912)

F2L 912 (Fig. 37)

When fitting a new piston,
take care that, on the direct-injection engine, the arrow marked on the piston points to the exhaust side.

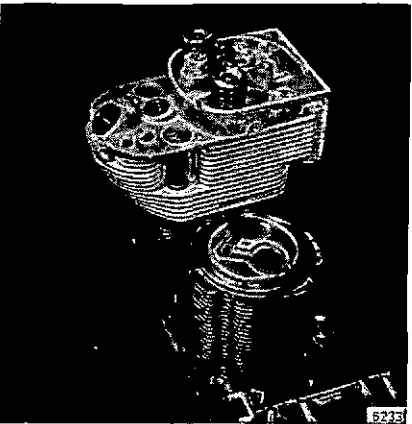

Fig. 38 (F2L 912 W)

2FL 912 W (Fig. 38)

When fitting a new piston,
take care that, on the two-stage combustion engine, the grooves in the piston crown point to the swirl chamber side of the cylinder head.

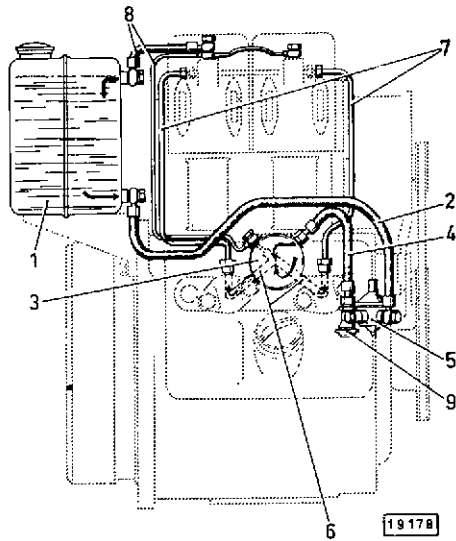

Fig. 39

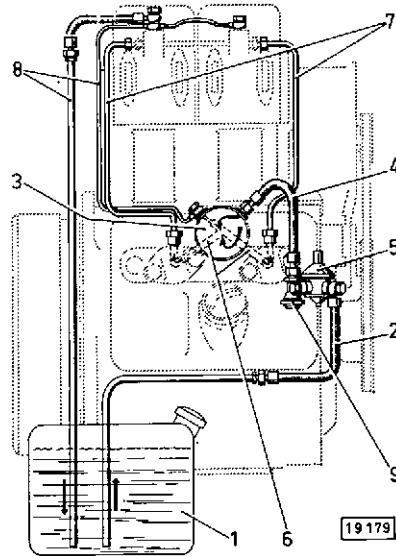

Fig. 40

Fuel Piping

With high- or low-level fuel tank

- 1 Fuel tank
- 2 Suction line
- 3 Fuel filter
- 4 Line from lift pump to filter
- 5 Lift pump
- 6 Piping in injection pump mounting cover
- 7 Injection lines
- 8 Spill lines
- 9 Diaphragm valve

PLEASE NOTE

The Maintenance Schedule illustrated overleaf is supplied with each engine as self-adhesive "sticker". This is to be adhered to the engine or to the equipment at a conspicuous point.

Should this Schedule be missing, ask your engine or equipment dealer to supply you with one.

SUMMARIZED INSTRUCTIONS

Checking Engine Oil Level

Starting

1. Isolate driven equipment by **declutching**.
2. Set speed control lever to 1/4 load position.

F 2 L 912

3. Insert starter key and turn clockwise. Do not operate starter motor uninterruptedly for more than 10 seconds.

At very low temperatures: See instructions on page 13.

F 2 L 912 W

4. Insert switchbox key (red charging indicator lights up). Turn heater plug/starter key to position 1. **Preheat** for at least one minute (and for 1 to 2 minutes at very low temperatures).

Heater plug indicator will go on.

Move heater plug/starter key to position 2: **starting**. Operate starter motor until engine fires, but for not more than 10 seconds. If engine will not fire, preheat again with heater plug/starter key in position 1.

After Starting

1. Check oil pressure.
2. Re-check oil level after a short trial run of engine.

Stopping

Never shut engine down suddenly from full load running, but let it idle for a short time to permit temperature balance.

1. Move speed control lever back.
2. Operate stopping lever until engine comes to rest.
3. Withdraw heater plug/starter key.
4. Withdraw switchbox key.

Total filling for oil changes: 4.5 liters.

Fuel filter cartridge: Q 0,5 H 4117

MAINTENANCE SCHEDULE

