

Operation Manual

B/FL 1011F

B/FM 1011F

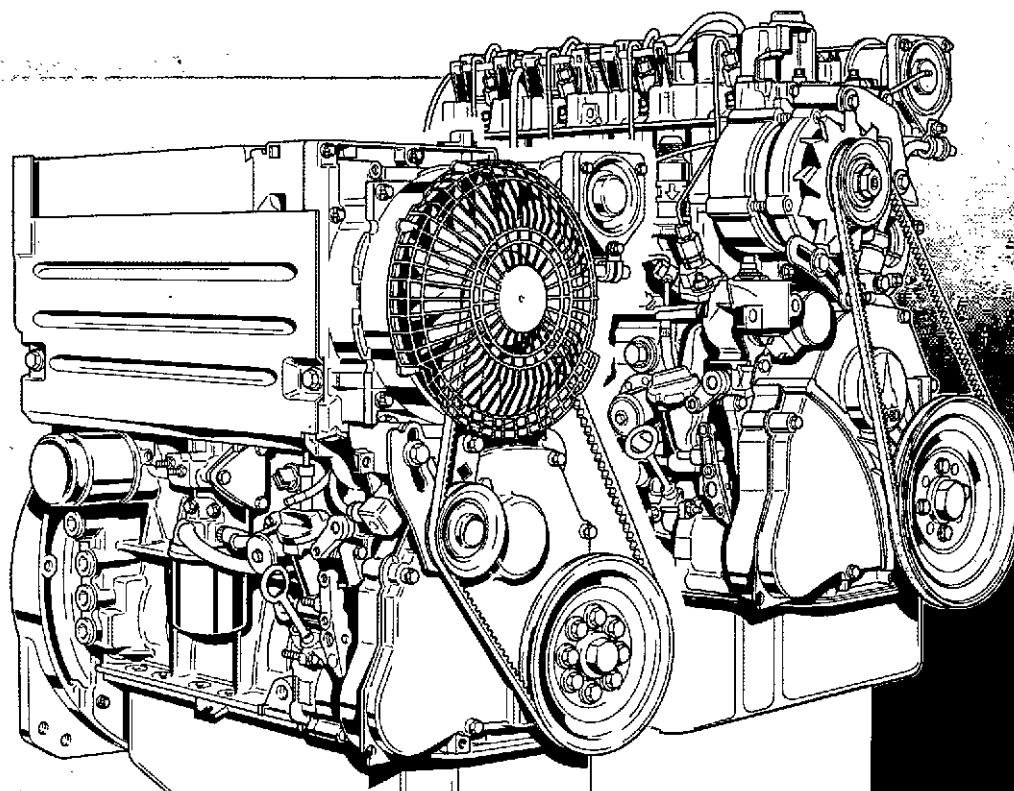

● Please read and observe the information given in this Operation Manual. This will enable you to avoid accidents, preserve the manufacturer's warranty and maintain the engine in peak operating condition.

● This engine has been built exclusively for the application specified in the scope of supply – as described by the equipment manufacturer – and is to be used only for the intended purpose. Any use *exceeding that scope is considered to be contrary* to the intended purpose. The manufacturer will not assume responsibility for any damage resulting therefrom. The risks involved are to be borne solely by the user.

● Use in accordance with the intended purpose also implies compliance with the conditions laid down by the manufacturer for operation, maintenance and servicing. The engine should only be operated by personnel trained in its use and the hazards involved.

● The relevant accident prevention guidelines and other generally accepted safety and industrial hygiene regulations must be observed.

● Unauthorized engine modifications will invalidate any liability claims against the manufacturer for resultant damage. Manipulations of the injection and regulating system may also influence the performance of the engine, and its emissions. Adherence to legislation on pollution cannot be guaranteed under such conditions.

● Do not change, convert or adjust the cooling air intake area.

The manufacturer shall not be held responsible for any damage which results from such work.

Operation Manual

B/FL 1011F

B/FM 1011F



0297 7118 en

Engine Serial Number

--	--	--	--	--	--	--	--	--	--

Please enter the engine serial number here. This number should be quoted when inquiring about Customer Service, Repairs or Spare Parts (see Section 2.1).

All rights reserved. Technical modifications required to improve our engines are reserved with regard to specification data and other technical information contained in this Operation Manual. No parts of this Manual may be reproduced in any form or by any means without our written approval.



Foreword

Dear Customer,

Air / liquid-cooled DEUTZ engines are designed for a large number of applications. Consequently, a wide range of variants are offered to meet the requirements of specific cases.

Your engine is appropriately equipped for the installation concerned, which means that not all of the components described in this Operation Manual are necessarily mounted to your engine.

We have endeavored to highlight any differences so that you will be able to locate the operating and maintenance instructions relevant to your engine quickly and easily.

Please read this Manual before starting your engine, and always observe the operating and maintenance instructions.

We are available to help with any additional inquiries

Sincerely,

DEUTZ SERVICE INTERNATIONAL GmbH

1	General	3.5	Operating Conditions	6.6	Adjustments
2	Engine Description	3.5.1	Winter Operation	6.6.1	Checking / Adjusting Valve Clearances
2.1	Model	3.5.2	High Ambient Temperature, High Altitude	6.7	Accessories
2.1.1.	Rating Plate	4	Operating Media	6.7.1	Battery
2.1.2	Rating Plate Location	4.1	Lube Oil	6.7.2	Three-Phase Alternator
2.1.3	Engine Serial Number	4.1.1	Quality Grade	6.7.3	Lifting Tackle
2.1.4	Cylinder Numbering	4.1.2	Viscosity	6.7.4	Ether Starting System
2.1.5	Fuel Delivery Lock	4.2	Fuel Operating Media	6.8.1	Engine Cleaning
2.2	Engine Illustrations	4.2.1	Quality Grade	7	Troubleshooting
2.2.1	Service Side FL 1011F	4.2.2	Winter-Grade Fuel	7.1	Diagnostic chart
2.2.2	Exhaust Side FL 1011F	5	Routine Maintenance	8	Engine Preservation
2.2.3	Service Side BFL 1011F	5.1	Maintenance Schedule	8.1	Preservation
2.2.4	Exhaust Side BFL 1011F	5.2	Maintenance Chart	8.1.1	Preserving Engine
2.2.5	Service Side FM 1011/ F	5.3	Maintenance Work Completed	8.1.2	Removing Engine Preservations
2.2.6	Exhaust Side FM 1011/ F	6	Service and Maintenance	9	Technical Specification
2.2.7	Service Side BFM 1011F	6.1	Lubrication System	9.1	Engine Specifications and Settings
2.2.8	Exhaust Side BFM 1011F	6.1.1	Oil Change Intervals	9.2	Torque Wrench Settings
2.3	Oil Circuit	6.1.2	Changing Engine Oil, Check Oil Level	9.3	Tools
2.3.1	Lube Oil Circuit	6.1.3	Changing Oil Filter		
2.4	Fuel System Schematic	6.2	Fuel System		
2.4.1	Fuel System	6.2.1	Changing Fuel Filter		
3	Engine Operation	6.2.2	Clean Strainer of Fuel Filter		
3.1	Commissioning	6.3	Cooling System		
3.1.1	Adding Engine Oil	6.3.1	Cleaning Intervals		
3.1.2	Filling oil bath air filter with engine oil	6.4	Combustion Air Cleaner		
3.1.3	Adding Fuel	6.4.1	Cleaning Intervals		
3.1.4	Other Preparations	6.4.2	Emptying Cyclone Type Precleaner		
3.1.5	Additional Maintenance Work	6.4.3	Cleaning Oil Bath Air Cleaner		
3.2	Starting	6.4.4.	Dry Type Air Cleaner		
3.2.1	Starting	6.5	Belt Drives		
3.3	Monitoring Systems	6.5.1	Checking V-Belts		
3.3.1	Engine Oil Pressure	6.5.2	Tensioning V-Belts		
3.3.2	Coolant Temperature	6.5.3	Changing V-Belts		
3.4	Stopping				
3.4.1	Mechanical Shutdown				
3.4.2	Electrical Shutdown				

1
2
3
4
5
6
7
8
9
10

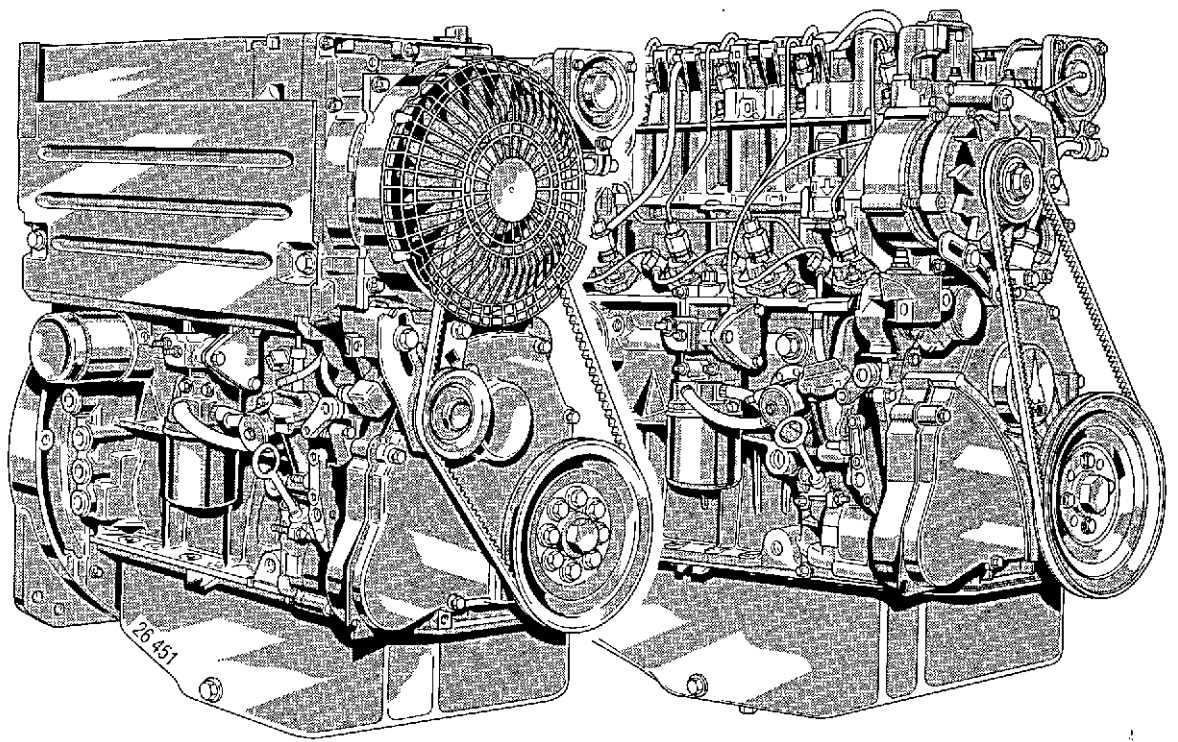

DEUTZ Diesel Engines

are the product of many years of research and development. The resulting know-how, coupled with stringent quality standards, guarantee their long service life, high reliability and low fuel consumption.

It goes without saying that the highest standards for environmental protection are met.

Service and Maintenance

Sound service and maintenance practices will ensure that the engine continues to meet your requirements.

Recommended service intervals must be observed and maintenance work carried out conscientiously. Special care should be taken under abnormally demanding operating conditions.

DEUTZ SERVICE INTERNATIONAL GmbH

Please contact one of our authorized service representatives in the event of breakdowns or for spare parts inquiries. Our trained specialists will carry out repairs quickly and professionally, using only genuine spare parts. Genuine spare parts from DEUTZ SERVICE INTERNATIONAL GmbH are always manufactured to the highest technical standards.

A table of DEUTZ SERVICE INTERNATIONAL GmbH contact numbers is given at the end of this Operation Manual.

1

Beware of Running Engine

Shut the engine down before carrying out maintenance or repair work. Ensure that the engine cannot be accidentally started – accidents may otherwise occur –.

When the work is complete, be sure to refit any panels and guards that have been removed.

Never fill the fuel tank while the engine is running. Observe industrial safety regulations when running the engine in an enclosed space or underground.

Safety

All safety instructions in this Manual are designated by the accompanying symbol. Please follow them carefully. The attention of operating personnel should be drawn to these safety instructions.

General safety and accident prevention regulations laid down by law must also be observed.

Asbestos

The seals and gaskets used in this engine are asbestos-free. When carrying out maintenance and repair work, please use appropriate spare parts.

- 2.1 Model**
- 2.2 Engine Illustration**
- 2.3 Lube Oil Circuit Schematic**
- 2.4 Fuel System Schematic**

2

2.1.1 Rating Plate

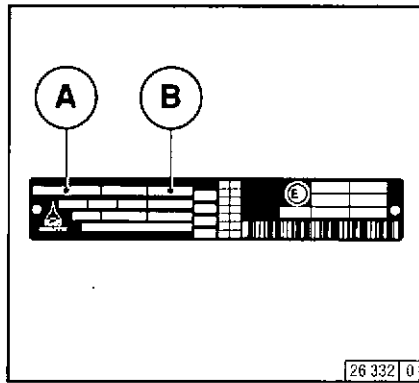

The model **A**, the engine serial number **B** and the performance data are stamped on the rating plate. The model and engine serial number must be given when ordering parts.

2.1.2 Rating Plate Location

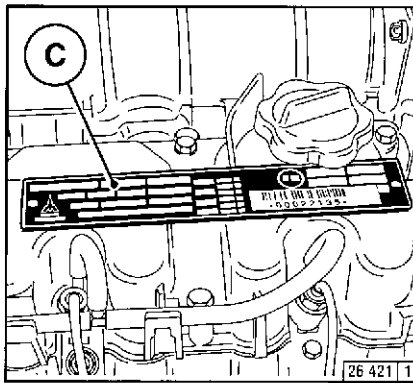

The rating plate **C** is attached to the valve cover.

2.1.3 Engine Serial Number

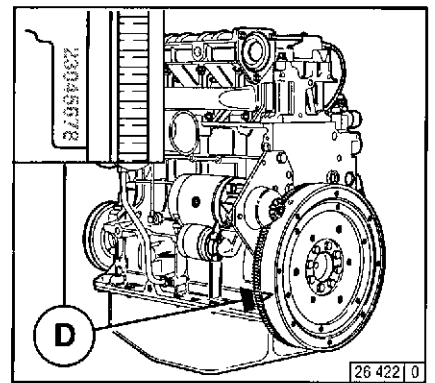

The engine serial number **B** is stamped on the crankcase **D** as well as the rating plate.

2.1.4 Cylinder Numbering

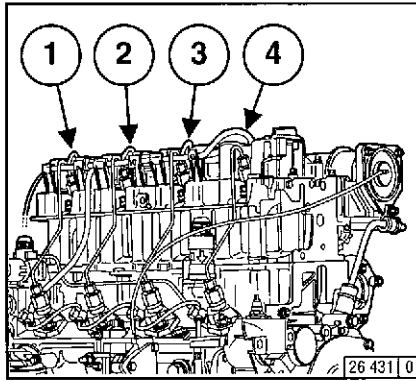

Cylinders are numbered consecutively, beginning at the flywheel end.

2.1.5 Fuel Delivery Lock

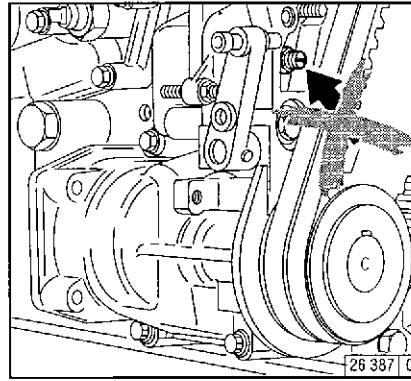

The manufacturer shall not be held liable for damages resulting from adjustments made to the regulator by the operator.

The lock screws are protected in order to prevent this:

1. with locking paint on model:
torque balancer
2. with plastic protective cap on model:
without torque balancer.



Adjustments to the regulator are to be carried out only by authorized DEUTZ SERVICE - specialists.

2.2.1 Service Side FL 1011F

2

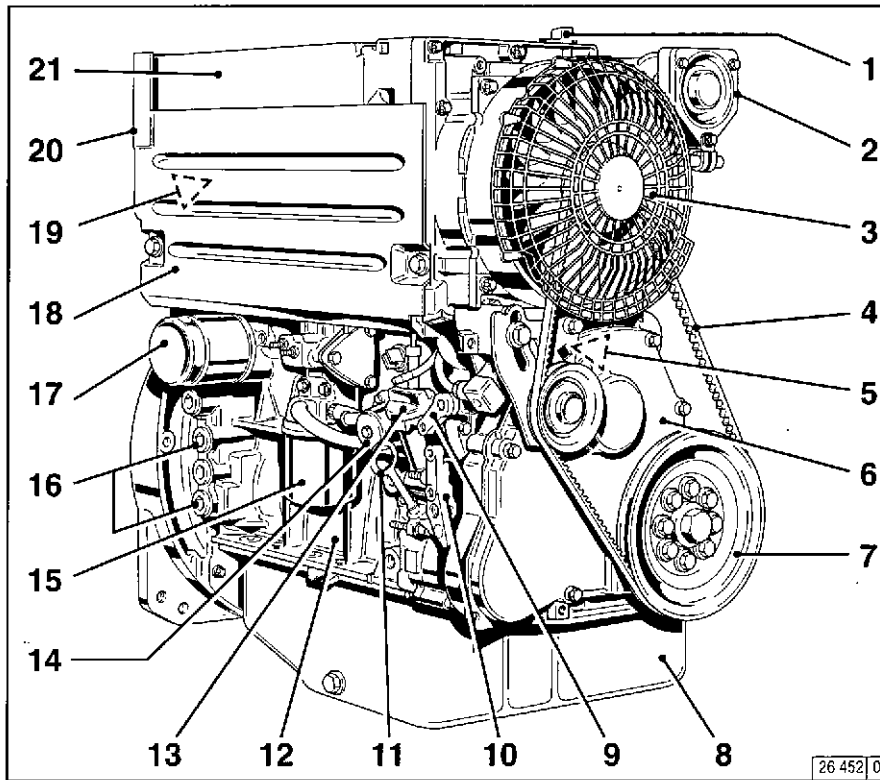

- 1 Oil filler neck (valve-gear cover)
- 2 Charge-air line / air-intake line
- 3 Fan with integrated generator
- 4 Narrow V-belt
- 5 Solenoid
- 6 Toothed belt cover
- 7 V-belt pulley on crankshaft
- 8 Oil sump
- 9 Cut-out handle
- 10 Speed control lever
- 11 Oil dipstick
- 12 Crankshaft housing
- 13 Oil fill point (on side of crankcase)
- 14 Fuel pump
- 15 Easy-change fuel filter
- 16 Connecting facility for oil heater
- 17 Lube oil easy-change filter
- 18 Removable coolant intake hood
- 19 Injection pumps
- 20 Date plate
- 21 Oil cooler

2.2.2 Exhaust side FL 1011F

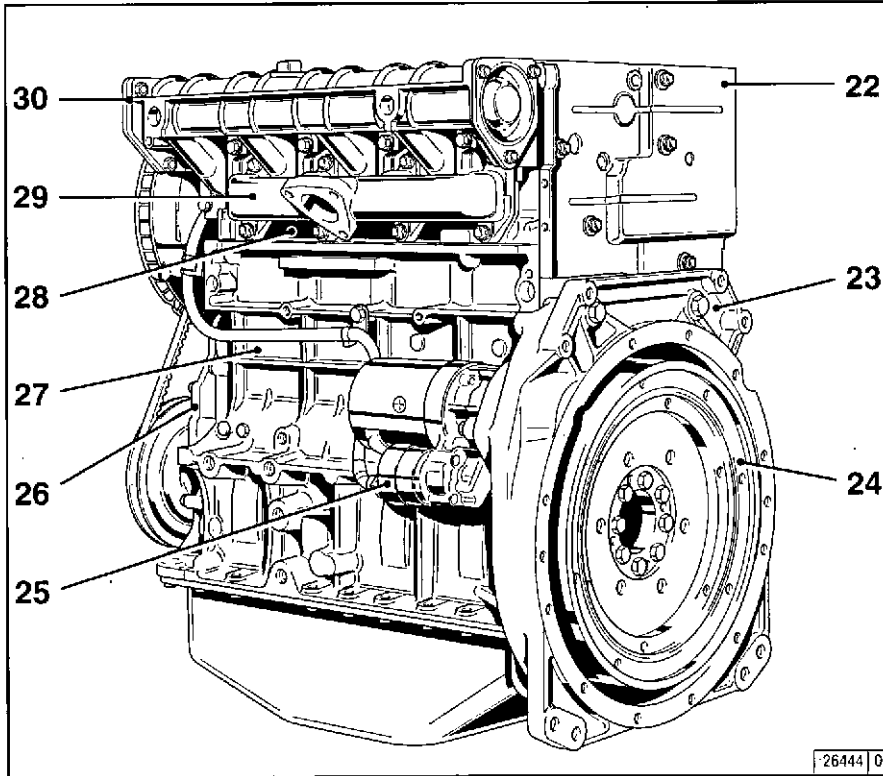

- 22 Date plate
- 23 Connection housing (SAE)
- 24 Flywheel with ring gear
- 25 Starter
- 26 Front cover
- 27 Crankcase
- 28 Cylinder head
- 29 Exhaust manifold pipe
- 30 Air-intake pipe

2.2.3 Service Side BFL 1011F

2

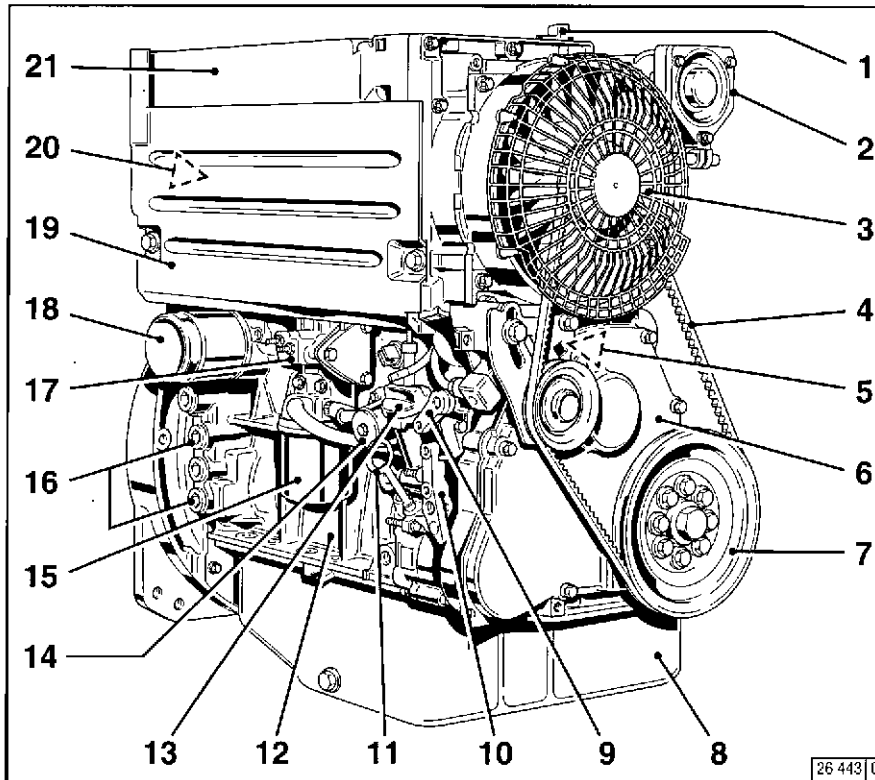

- 1 Oil filler neck (valve-gear housing cover)
- 2 Charge-air line / air-intake line
- 3 Fan with integrated generator
- 4 Narrow V-belt
- 5 Solenoid
- 6 Wheel-house cover
- 7 V-belt pulley on crankshaft
- 8 Oil sump
- 9 Cut-out handle
- 10 Speed control lever
- 11 Oil dipstick
- 12 Crankshaft housing
- 13 Oil fill point (on side of crankcase)
- 14 Fuel pump
- 15 Easy-change fuel filter
- 16 Connection facility for oil heater
- 17 Charge-air pressure full-load stop (LDA)
- 18 Lube oil easy-change filter
- 19 Removable coolant intake hood
- 20 Injection pumps
- 21 Oil cooler

2.2.4 Exhaust side BFL 1011F

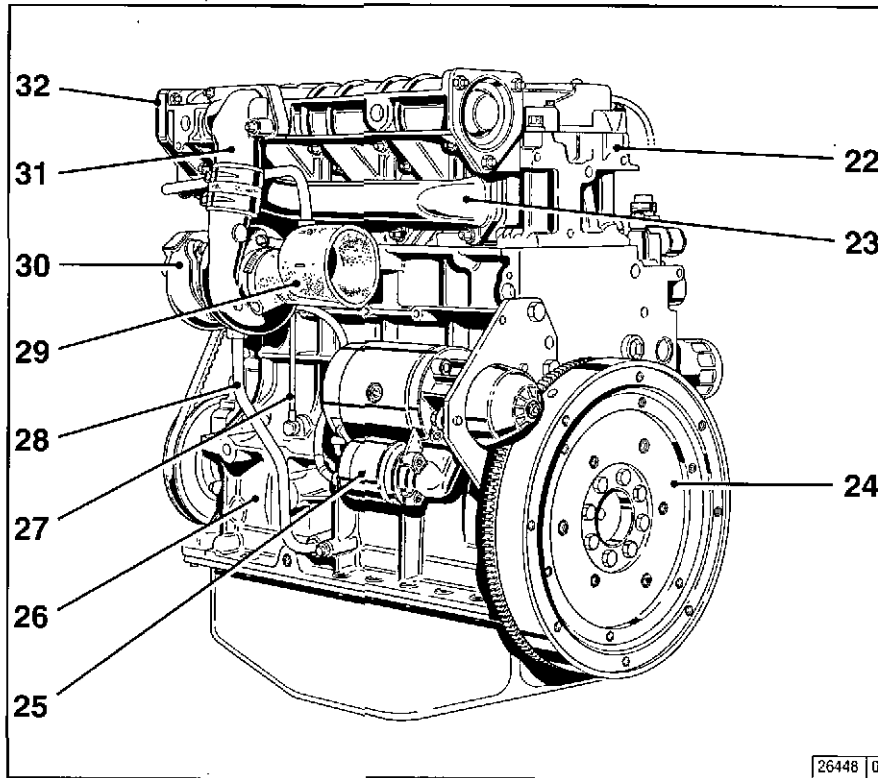

- 22 Cylinder head
- 23 Exhaust manifold pipe
- 24 Flywheel with ring gear
- 25 Starter
- 26 Crankshaft housing
- 27 Inlet line to TC (Lube oil)
- 28 Return line from TC (Lube oil)
- 29 Induction pipe
- 30 Turbocharger (TC)
- 31 Intake manifold
- 32 Air-intake line

2.2.5 Service Side FM 1011F

2

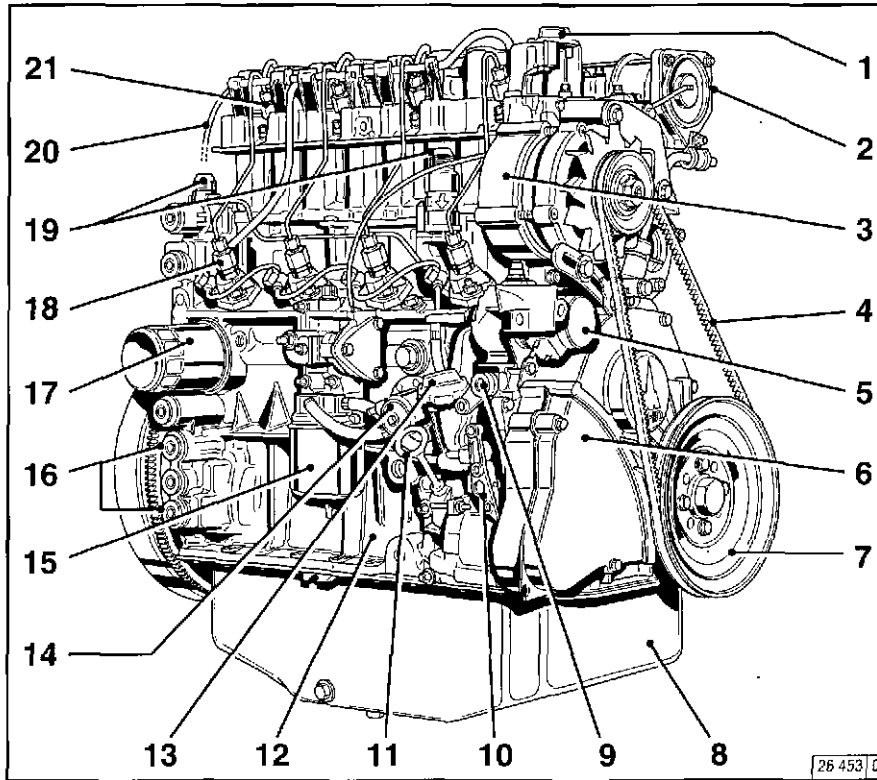

- 1 Oil filler neck (valve-gear housing)
- 2 Charge-air line / air-intake line
- 3 Generator
- 4 Narrow V-belt
- 5 Solenoid
- 6 Wheel-house cover
- 7 V-belt pulley on crankshaft
- 8 Oil sump
- 9 Cut-out handle
- 10 Speed control lever
- 11 Oil dipstick
- 12 Crankshaft housing
- 13 Oil fill point (on side of crankcase)
- 14 Fuel pump
- 15 Easy-change fuel filter
- 16 Connecting facility for oil heater
- 17 Lube oil easy-change filter
- 18 Injection pumps
- 19 Connection for oil cooler
- 20 Leakage-fuel line
- 21 Injection valves

2.2.6 Exhaust side FM 1011F

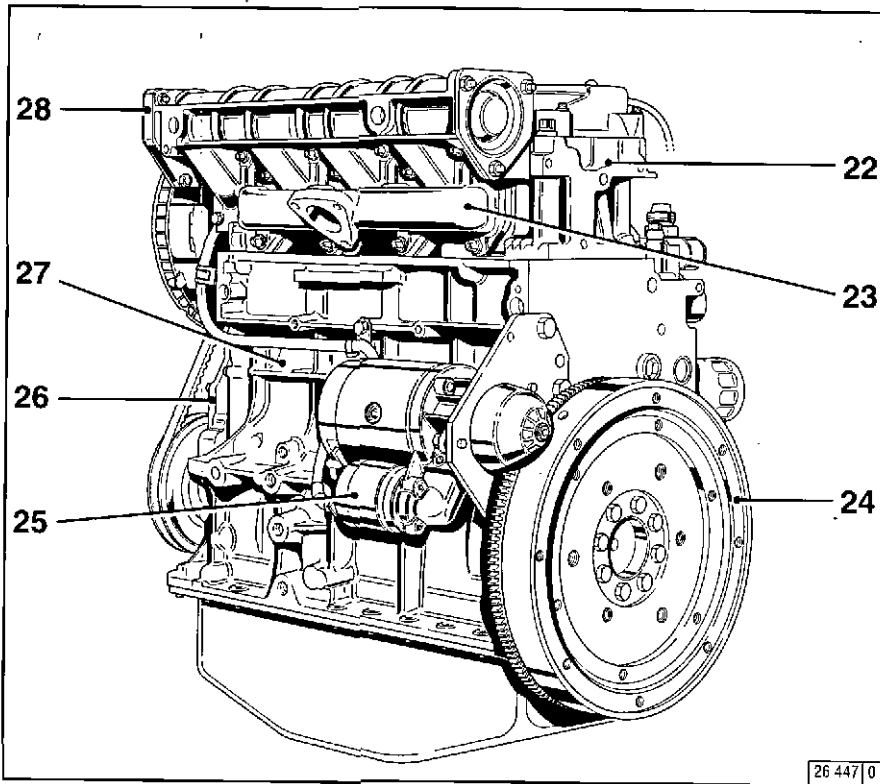

- 22 Cylinder head
- 23 Exhaust manifold line
- 24 Flywheel with ring gear
- 25 Starter
- 26 Front cover
- 27 Crankcase
- 28 Intake pipe

2.2.7 Service Side BFM 1011F

2

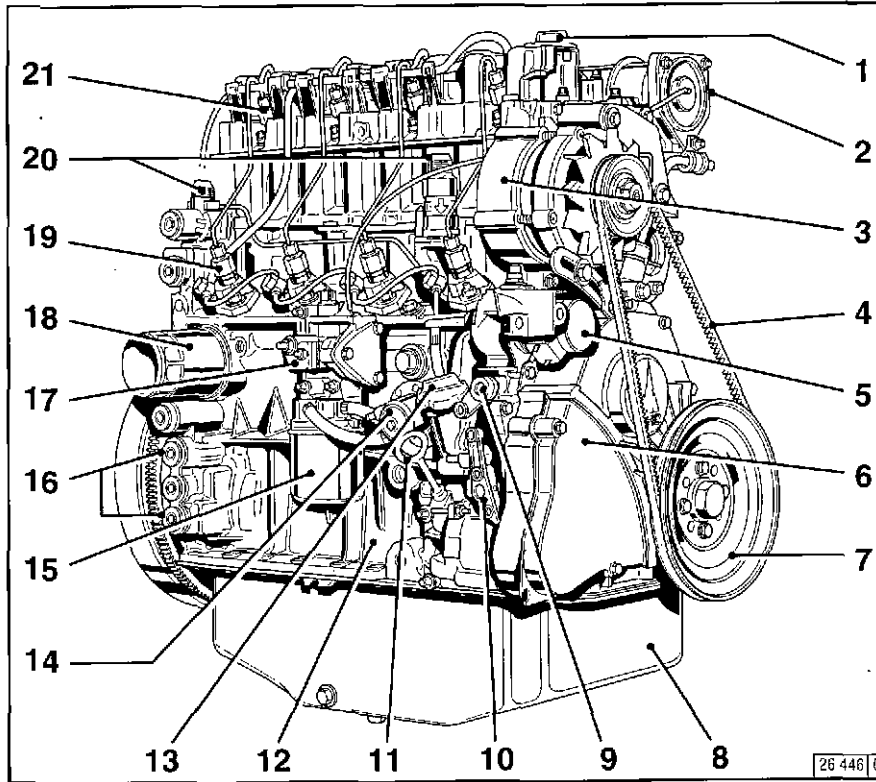

- 1 Oil filler neck (valve-gear housing cover)
- 2 Charge-air line / air-intake line
- 3 Generator
- 4 Narrow V-belt
- 5 Solenoid
- 6 Wheel-house cover
- 7 V-belt on crankshaft
- 8 Oil sump
- 9 Cut-out handle
- 10 Speed control lever
- 11 Oil dipstick
- 12 Crankshaft housing
- 13 Oil fill point (on side of crankcase)
- 14 Fuel pump
- 15 Easy-change fuel filter
- 16 Connecting facility for oil heater
- 17 Charge-air pressure full-load stop (TC)
- 18 Lube oil easy-change
- 19 Injection pumps
- 20 Oil cooler connection
- 21 Injection valves

2.2.8 Exhaust side BFM 1011F

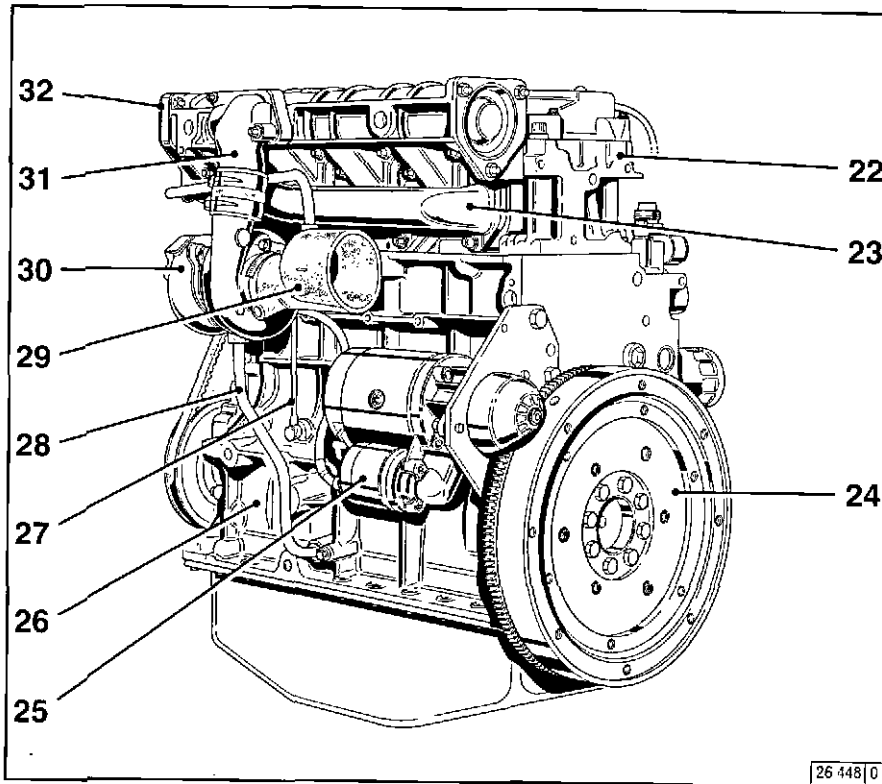

- 22 Cylinder head
- 23 Exhaust manifold pipe
- 24 Flywheel with ring gear
- 25 Starter
- 26 Crankshaft housing
- 27 Inlet line to TC (Lube oil)
- 28 Return line from TC (Lube oil)
- 29 Induction pipe
- 30 Turbocharger (TC)
- 31 Intake manifold
- 32 Air-intake line

26 448 0

2.3.1 Lube Oil Circuit Schematic

2

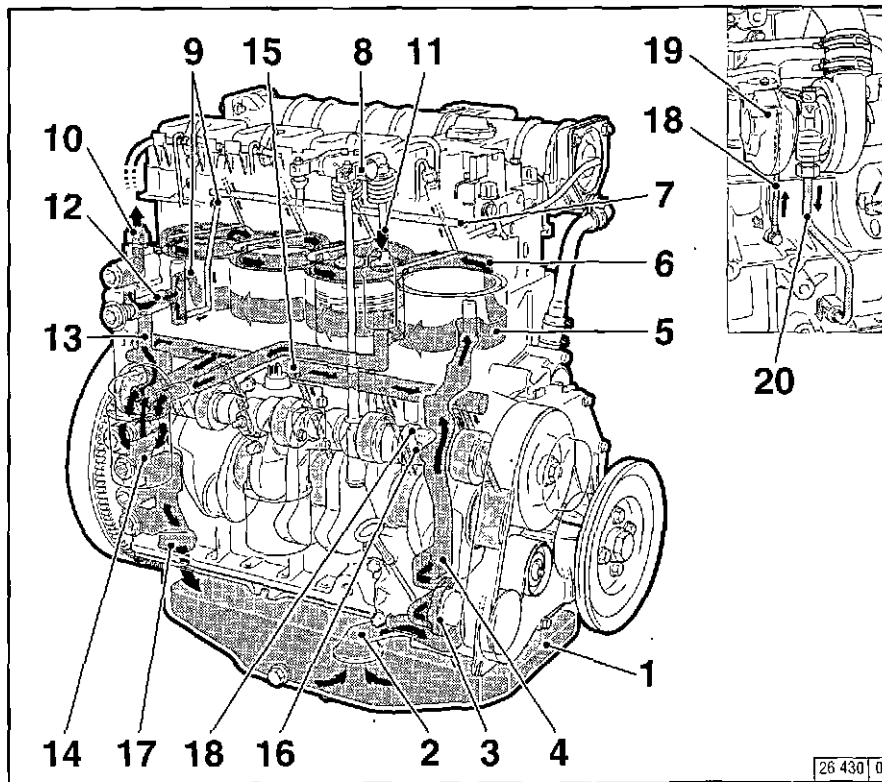

- 1 Oil sump
- 2 Intake manifold
- 3 Oil pump
- 4 Main oil duct
- 5 Oil-cooled cylinder
- 6 Cylinder head cooling neck
- 7 Oil duct for rocker arm lubrication
- 8 Rocker arm
- 9 Oil manifold for the thermostat
- 10 Intake to external engine oil cooler
- 11 Return from external engine oil cooler
- 12 Thermostat housing with slide thermostat
- 13 Oil duct to oil filter
- 14 Oil filter
- 15 Oil duct to the cam, con-rod and crankshaft bearing
- 16 Injection jet for cooling the pistons
- 17 Oil return via crankcase to the oil sump
- 18 Lube oil intake to turbocharger
- 19 Turbocharger
- 20 Return from turbocharger to oil sump

26 430 0

2.4.1 Fuel system schematic

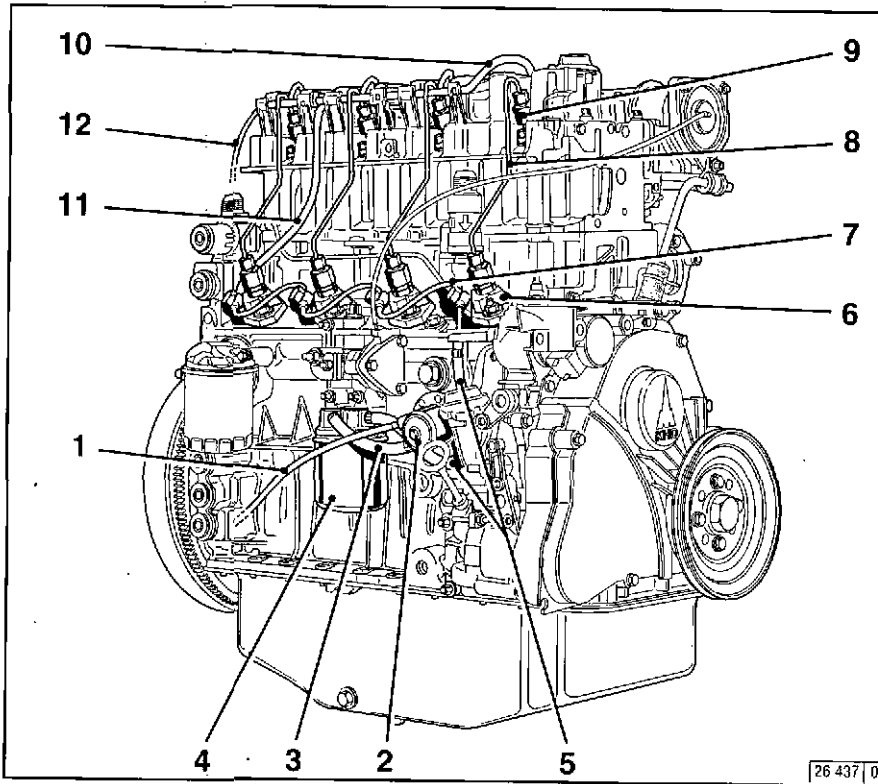

- 1 Fuel line from tank to fuel pump
- 2 Fuel pump
- 3 Fuel line from fuel pump to easy-change fuel filter
- 4 Easy-change fuel filter
- 5 Fuel line from filter to injection pump
- 6 Injection pumps
- 7 Fuel distributor line
- 8 Injection lines
- 9 Injection valves
- 10 Fuel leakage line
- 11 Fuel overflow pipe
- 12 Fuel return line to tank

- 3.1 Commissioning**
- 3.2 Starting**
- 3.3 Monitoring Systems**
- 3.4 Stopping**
- 3.5 Operating Conditions**

3.1.1 Adding Engine Oil

3.1.1.1 Initial Engine Oil Fill-Up for B/FM1011F Series

3.1.1.2 Initial Engine Oil Fill-up for B/FM 1011F Series

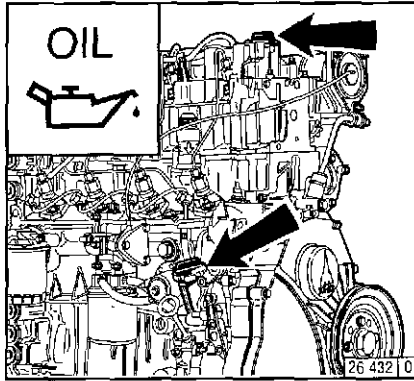

- Fill oil into the oil sump up to the "max." mark on the engine dip stick (for oil top-up quantity see 9.1).
- Start the engine and allow to run at a low idling speed for approx. 2 mins.
- Switch off the engine.
- Check the oil level, if necessary, top up oil to the „max.“ mark.

- Fill oil into the oil sump up to the "min." mark on the engine dip stick.
- In addition, top up the oil quantity of the supply hoses and of the external oil cooler (according to manufacturer's details).
- Allow the engine to run warm until the thermostat opens (at approx. 95°C).
- Allow the engine to run for approx. 2 mins.
- Switch off the engine.
- Check the oil level, and if necessary, top up oil to the „max.“ mark.

As a rule, engines are delivered empty of oil. Pour lube oil into the oil filler neck (arrow). For oil grade and viscosity, see 4.1.

If the person operating the engine does not run up the engine until the thermostat opens, the oil level may lie above the „max“ mark on the engine dip stick when delivered. The level can then only be assessed after the engine has been run up.

3.1.1.3 Initial Engine Oil Fill-Up for B/FM 1011F Genset Engine

- Fill oil into the oil sump up to the "max." mark on the engine dip stick (for oil quantity see 9.1).
- Start up the engine and allow to run at a lower idling speed for approx. 2 mins.
- Switch off the engine.
- Check the oil level and fill up with oil up to the upper „max.“ mark.

3.1.2 Filling Oil Bath Air Filter with Engine Oil

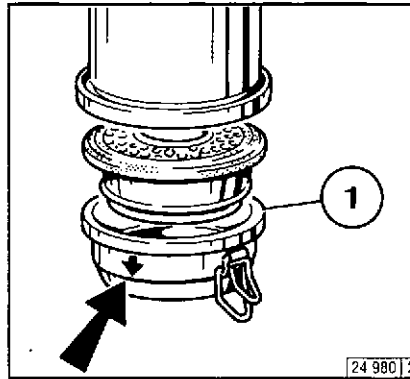

Fill oil cup 1 of the oil bath air cleaner with oil up to the arrow.
For oil grade and viscosity, see 4.1.

3.1.3 Adding Fuel

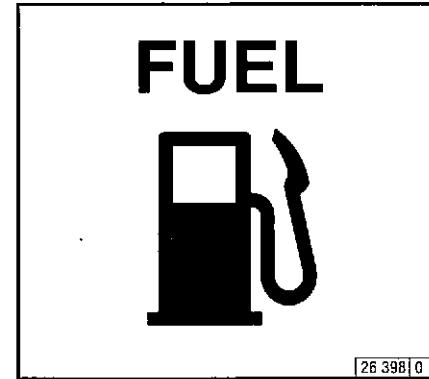

Use only commercial-grade diesel fuel. For fuel grade, see 4.2. Use summer or winter-grade fuel, depending on the ambient temperature.



Do not fill the precleaner dust collector (if fitted) with oil.



Never fill the tank while the engine is running. Keep the filler cap area clean and do not spill fuel.

3.1.4 Other Preparations

- Check battery and cable connections, see 6.7.1

- Transport hooks
Remove if fitted (see 6.7.3)

- Trial run
After the engine has been prepared, let it run for about 10 minutes without load.

During and after trial run

- Check the engine for leaks

After the engine has been turned off

- Check the oil level,
see 6.1.2

If necessary, top up oil,
see 3.1.1

- Retension V-belts, see 6.5

- Breaking in
During the break-in phase – about 200 operating hours – check the oil level twice a day. After the engine is broken in, checking once a day will be sufficient.

3.1.5 Additional Maintenance Work

The following maintenance should be carried out after 50-150 operating hours:

- Change lube oil,
see 6.1.2
- Change oil filter cartridge,
see 6.1.3
- Change fuel filter cartridge,
see 6.2.1
- Check V-belts and retension as necessary,
see 6.5.
- Check valve clearance and adjust as necessary, see 6.6.1
- Check the engine for leaks
- Check the engine mount and adjust as necessary, see 9.2

3.2.1 Electric Starting

3



Before starting, make sure that nobody is standing in the immediate vicinity of the engine or driven machine. After repair work:

Check that all guards have been replaced and that all tools have been removed from the engine.

When starting with glow plugs, do not use any other starter substance (e.g. injection with start pilot).

Caution: If the speed regulator has been removed, the engine must not be tested under any circumstances:

Disconnect the battery.

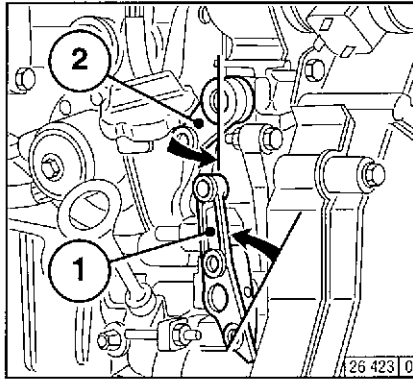

- Where possible, disengage the clutch to separate the engine from any driven parts.
- Move speed control lever 1 into idle position.
- Move cut-out handle 2 into operating position.

Starting without Cold-Start Aid

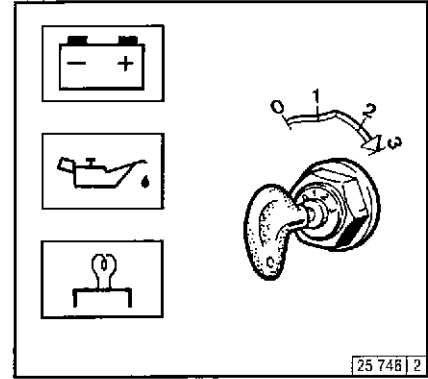

- Insert key.
 - Position 0 = no operating voltage
- Turn key clockwise
 - Position 1 = operating voltage
 - Pilot lights come on
- Push the key in and turn it further clockwise against spring pressure
 - Position 2 = no function
 - Position 3 = start
- Release key as soon as engine fires
 - Pilot lights go out

Do not actuate the starter for more than 20 seconds. If the engine does not catch, wait a minute then try again.

If the engine does not catch after two attempts, refer to the Diagnosis Chart (see 7.1).

with Cold-Start Aid - Glow Plug

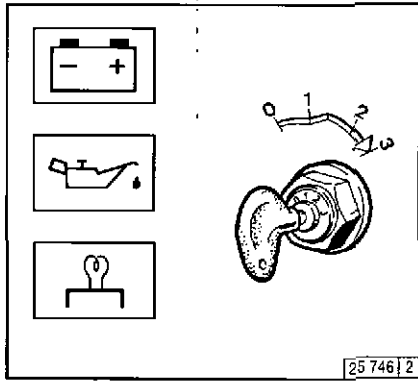

- Insert key.
 - Position 0 = no operating voltage
- Turn key clockwise
 - Position 1 = operating voltage
 - Pilot lights come on
- Push key in and turn further clockwise against spring pressure
 - Position 2 = Preheat, hold for approx. 1 minute.
 - Preheat lamp comes on
 - Position 3 = Start
- Release key as soon as engine fires
 - Pilot lights go out

with Cold-Start Aid - Ether Starting System

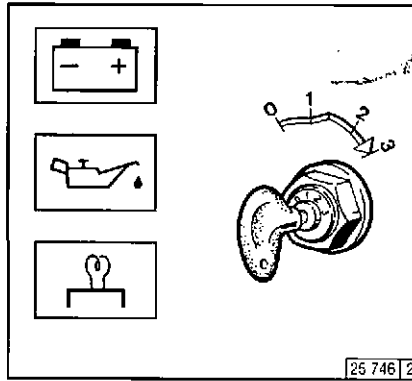

- Insert key.
 - Position 0 = no operating voltage
- Turn key clockwise
 - Position 1 = operating voltage
 - Pilot lights come on
- Push key in and turn further clockwise against spring pressure
 - Position 2 = no function
 - Position 3 = start
- Release key as soon as engine fires
 - Pilot lights go out

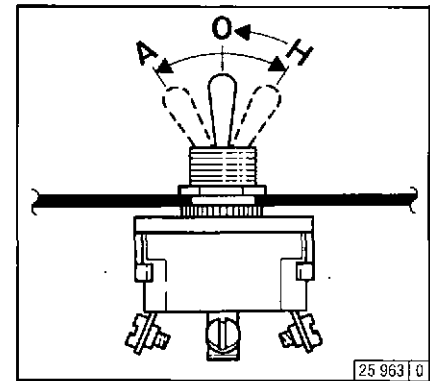

- Starting fluid is injected automatically in switch position **A**, as long as the starter is operated.
- To assist acceleration at lower temperatures and to avoid white fumes, briefly hold the arctic switch in switch position **H**.



The switch must not be moved to position **H** when the engine is switched off and the ignition is switched on.

3.3.1 Engine Oil Pressure Oil Pressure Pilot Light

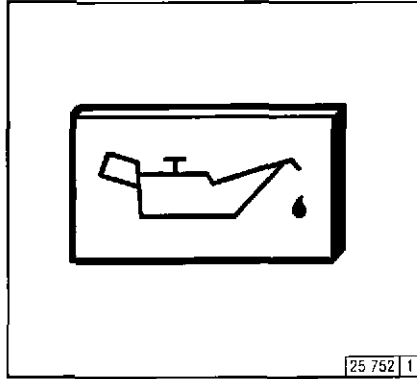

- The oil pressure pilot light comes on with operating voltage on and engine off.
- The oil pressure pilot light should go out when the engine is running.

Oil Pressure Indicator

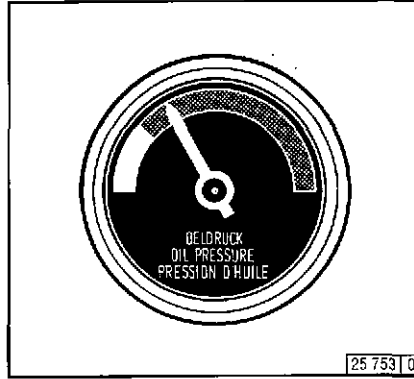

- The pointer must remain in the green sector over the entire range.

Oil Pressure Gauge

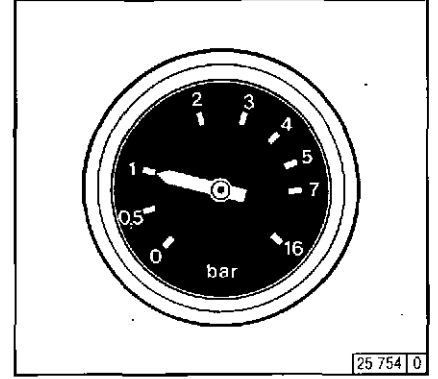

- The pointer must indicate the minimum oil pressure (see 9.1).

3.3.2 Coolant Temperature Engine Temperature Gauge

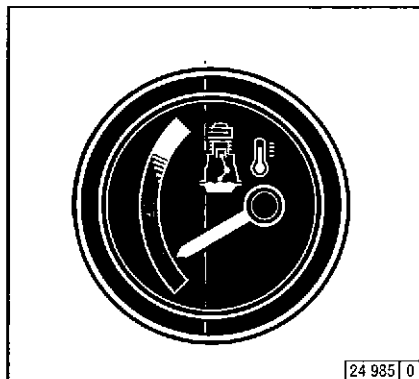

- The engine temperature gauge pointer should remain in the green sector most of the time. It should rarely enter the yellow-green sector. If the pointer enters the orange sector, the engine is overheating. Turn off and establish the cause from the Diagnosis Chart (see 7.1).

3

3.4.1 Mechanical Shutdown

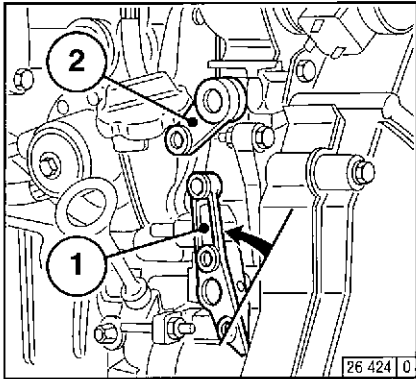

- Move speed control lever 1 to low idle.
- Operate shutdown lever 2 until the engine comes to a stop. The charge pilot light and the oil pressure pilot light will come on when the engine stops.
- Turn key counterclockwise (to position 0) and remove. The pilot lights will go out.

3.4.2 Electrical Shutdown (Ignition Key)

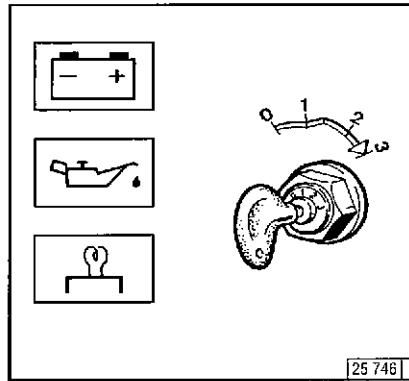

- Turn key counterclockwise (to position 0) and remove. The pilot lights will go out.

If possible, do not suddenly switch off the engine when under full load.

3.5.1 Winter Operation

- **Lube Oil Viscosity**
 - Select the oil viscosity (SAE grade) according to the ambient temperature when the engine is started, see 4.1.2.
 - Increase oil change frequency when operating below -10°C , see 6.1.1.
- **Diesel Fuel**
 - Use winter-grade diesel fuel for operation below 0°C , see 4.2.2.
- **Additional Maintenance Work**
 - Drain the sludge from the fuel tank once a week. (Unscrew the sludge drain plug)
 - If necessary, allow the oil in the oil bath air cleaner and the engine oil to settle at the ambient temperature.
 - Below -20°C , after removing the starter if necessary, smear the ring gear on the fly wheel via the pinion bore from time to time with cold-resistant grease. (e.g. Bosch grease FT 1 V 31).
- **Cold-Start Aid**
 - At temperatures near or below freezing point, use glow plugs if necessary, see 3.2.1. This not only lowers the starting limit temperature, but provides easier starting at temperatures normally not requiring a starting aid.

- **Battery**
 - Efficient cold starting requires a healthy battery, see 6.7.1.
 - The starting limit temperatures can be lowered by $4-5^{\circ}\text{C}$ by heating the battery up to about $+20^{\circ}\text{C}$. (To do so, remove the battery and store in a warm place).

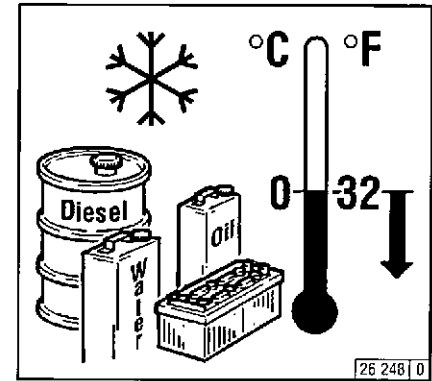

3.5.2 High Ambient Temperatures, High Altitude

3

- As the altitude and ambient temperature rise, the density of air tends to decrease, which affects the maximum power output of the engine, the exhaust gas quality and, in extreme cases, the starting behavior. Under transient conditions, the engine can be used at altitudes up to 1000 m and temperatures up to 30°C. If the engine is to operate under more severe conditions (at higher altitudes or temperatures), it will be necessary to reduce the injected fuel quantity and thus, engine power.
- If you have any doubts about engine operation under these or similar conditions, ask your engine or equipment supplier whether the engine has been derated in the interests of reliability, service life and exhaust gas quality (smoke). Otherwise contact DEUTZ SERVICE.

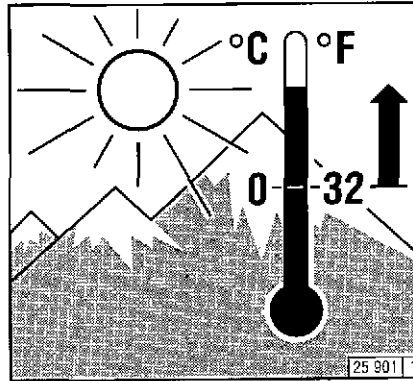

- 4.1 Lube Oil**
- 4.2 Fuel**

4.1.1 Quality grade

Lube oils are differentiated according to their performance and quality class. In common use are specifications named after the **API** (American Petroleum Institute) and **CCMC** (Committee of Common Market Automobile Constructors).

Approved API Oils:

Naturally aspirated engines: CC/SE CC/SF

Turbocharged engines: CD CF
CE CF-4

Approved CCMC Oils:

Naturally aspirated engines: D4

Turbocharged engines: C4 D5
D5 (sulphate-ash 1.8% by mass) corresponds to SHPD

* SHPD-(Super High Performance Diesel) oils.
If in doubt, ask the nearest service representative.

Oil change intervals, see 6.1.1
Oil capacities, see 9.1

4.1.2 Viscosity

As the viscosity of the lube oil is dependent on temperature, the choice of SAE grade should be governed by the ambient temperature prevailing at the engine operating site. Optimum operating behavior will be attained if you take the accompanying oil viscosity diagram as a guide.

Should the temperature fall temporarily below the limits of SAE grade selected, cold starting may be affected but the engine will not be damaged. In order to keep wear to a minimum, do not exceed application limits for extended periods of time. Oil changes dictated by the seasons can be avoided by using multi-grade lube oils. Multi-grade oils - particularly light-flowing oils - also reduce fuel consumption.

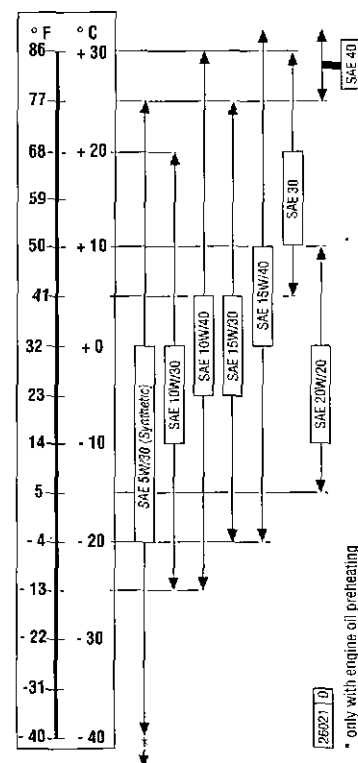

4.2.1 Quality Grade

Use commercially available diesel fuel with less than 0.5 % sulfur content. If the sulfur content is higher than 0.5 % oil change intervals should be reduced, see 6.1.1.

The following fuel specifications / standards are approved:

- DIN 51 601 (Febr. 1986)
- BS 2869: A1 and A2
(with A2, take note of the sulfur content)
- ASTM D 975-88; 1-D and 2-D
- CEN EN 590 or DIN EN 590
- NATO Code F-54 and F-75

4.2.2 Winter-Grade Fuel

Waxing may occur at low temperatures, clogging the fuel system and reducing engine efficiency. If the ambient temperature is less than 0 °C, winter-grade fuel (suitable down to -15 °C) should be used. (This fuel is usually available from the filling stations well in advance of the cold months). Diesel fuel containing additives (Super diesel) is often on sale as well, for use down to -20 °C.

- At temperatures below -15 °C to -20 °C, kerosene should be added to the diesel fuel. The relevant percentages are given in the adjacent diagram.

If summer-grade diesel fuel must be used at temperatures below 0 °C, up to 60% kerosene can be added (see diagram).

In most cases, adequate resistance to cold can be obtained by adding a flow improver (additive). Please inquire at DEUTZ SERVICE.

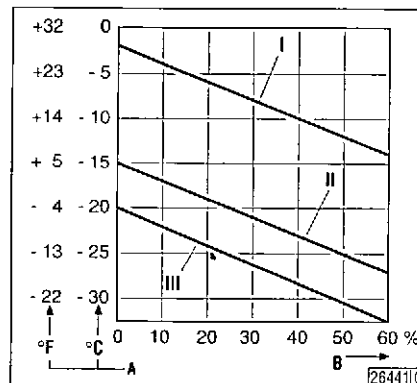

- I = Summer diesel fuel
- II = Winter diesel fuel
- III = Super diesel fuel

A = Ambient temperature

B = Proportion of Kerosene to be added



Mix in tank only. Fill with the appropriate amount of kerosene first, then add the diesel fuel.

- 5.1 Maintenance Schedule**
- 5.2 Maintenance Chart**
- 5.3 Maintenance Work Completed**

once after 2)	Operating Hours (OP) every 1)								check	clean	change	see Section										
	50-150	every 10 OH or daily	125	250	500	750	1000	2000					3000	Operation								
															●	●	●	●	●	●	●	●
●	●								●	Oil level in engine / separate container 9)	6.1.2/3.1.4											
●	●								●	Engine leaks												
	●								●	Oil bath and dry type air cleaners 3) 4) 5)	6.4											
		●							●	Battery and cable connectors	6.7.1											
		●	●	●		●	●		●	Cooling system (depending on engine use 3)	6.3.1/6.3.2											
●				●	7)	●	6)		●	Engine oil (depending on engine use) 4) 6)	6.1.1/6.1.2											
●				●	7)	●	6)		●	Oil filter cartridge (depending on oil change interval) 4) 6)	6.1.3											
●						●			●	Fuel filter cartridge	6.2.1											
●						●			●	Valve clearance (adjust if necessary)	6.6.1											
●						●			●	Engine mounts (retighten if necessary)	9.2											
●				●					●	V-belts (retensioning if necessary)	6.5											
						●			●	Toothed belts 8) 10)												
								●	●	Injection valves												
								●	●	Fuel pump / strainer 5)	6.2.2											

1) recommended maximum
 2) commissioning new or reconditioned engine
 3) clean if needed
 4) Oil quality API-CD or CCMC-D4 + D5
 5) change if required
 Wenn vorhanden nach Wartungsanzeiger warten.
 6) for oil change intervals, naturally aspirated engines. see Section 6.1.1
 7) for oil change intervals, turbocharged engines, see Section 6.1.1
 8) **without toothed belt ventilation** renew after 3000 running hours, after 5 years at the latest if running hours are not reached: in both cases together with idler pulley
with toothed belt ventilation renew after 4500 running hours, after 5 years at the latest if running hours are not reached: in both cases together with idler pulley
 9) during run-in period, check 2 x daily
 10) retensioning of toothed belts is not permitted

5.2 Maintenance Chart

Routine Maintenance

The maintenance chart shown here is supplied as a self-adhesive label with each engine. It should be affixed where it can be seen clearly on the engine or driven equipment.

Check that this is the case.

If necessary, ask your engine or equipment supplier for a fresh supply of labels.

Routine work should be carried out according to the schedule in 5.1.

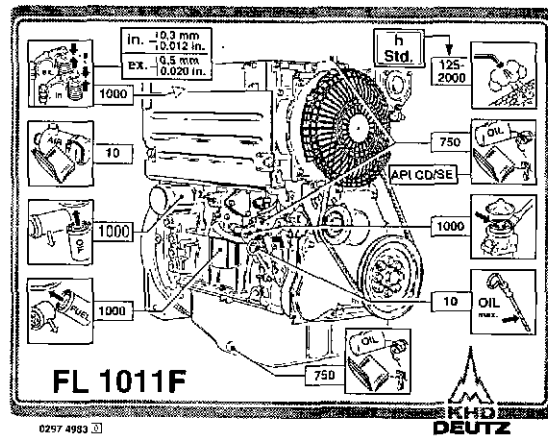

0297 4983 [E]

DEUTZ

5



Stop the engine before carrying out any maintenance work.

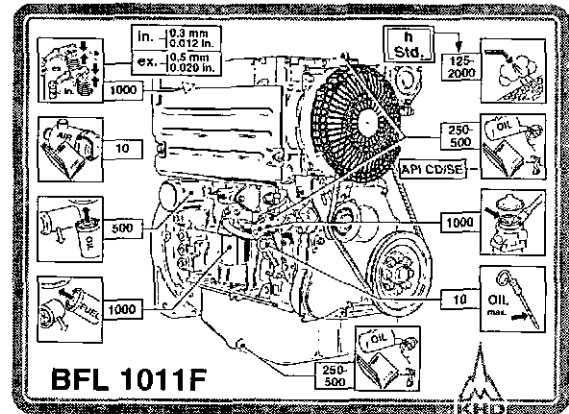

0297 4986 [E]

DEUTZ

The maintenance chart shown here is supplied as a self-adhesive label with each engine. It should be affixed where it can be seen clearly on the engine or driven equipment.

Check that this is the case.

If necessary, ask your engine or equipment supplier for a fresh supply of labels.

Routine work should be carried out according to the schedule in 5.1.

5

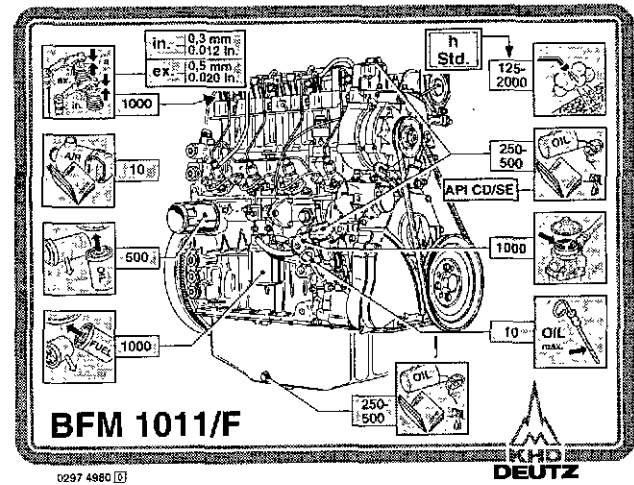
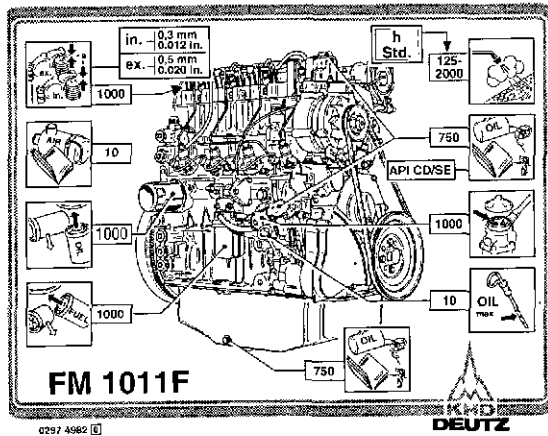

Stop the engine before carrying out any maintenance work.

5.3 Maintenance Work Completed

Routine Maintenance

OH	Date	Signature / Stamp	OH	Date	Signature / Stamp
* 50			—		
125			250		
375			500		
625			750		
875			1000		
1125			1250		
1375			1500		
1625			1750		
1875			2000		
2125			2250		
2375			2500		
2625			2750		

Duly completed maintenance jobs can be recorded and signed off in the above chart.
* After commissioning of new and reconditioned engines.

Routine Maintenance

5.3 Maintenance Work Completed

5

OH	Date	Signature / Stamp	OH	Date	Signature / Stamp
2875			3000		
3125			3250		
3375			3500		
3652			3750		
3875			4000		
4125			4250		
4375			4500		
4625			4750		
4875			5000		
5125			5250		
5375			5500		
5625			5750		

Duly completed maintenance jobs can be recorded and signed off in the above chart.

5.3 Maintenance Work Completed

Routine Maintenance

OH	Date	Signature / Stamp	OH	Date	Signature / Stamp
5875			6000		
6125			6250		
6375			6500		
6625			6750		
6875			7000		
7125			7250		
7375			7500		
7625			7750		
7875			8000		
8125			8250		
8375			8500		
8625			8750		

Duly completed maintenance jobs can be recorded and signed off in the above chart.

- 6.1 Lubrication System**
 - 6.2 Fuel System**
 - 6.3 Cooling System**
 - 6.4 Combustion Air System**
 - 6.5 Belt Drives**
 - 6.6 Adjustments**
 - 6.7 Accessories**
- Service and Maintenance**

6.1.1 Oil Change Intervals

- The oil change intervals are dependent on the engine application and the quality of the lube oil.
- If the engine runs fewer hours during the year than stated in the table, the oil should be changed at least once a year.
- The table refers to the following conditions:
 - For diesel fuel: sulfur content max. 0.5% by weight.
 - Continuous ambient temperatures down to -10 °C (+14 °F).
- If the sulfur content is > 0.5 to 1% or the continuous ambient temperature below -10 °C (+14 °F), the intervals between oil changes should be halved.

Installed engines			Lube oil intervals in OH		Lube oil intervals in OH	
			Naturally aspirated engines		Turbocharged engines	
Lube oil quality	API classification		CC 1)	CD/CE 1)	CD/CE/CF-4	CF-4
	CCMC classification		—	D4	D4	D5 2) (SHPD) 3)
Normal oil usage, e.g.:						
Road vehicles, cranes, construction machinery, ships, electrical units, pumps, rail-run vehicles			500	1000	250	500
Heavy-duty oil usage, e.g.:						
Combine harvesters, emergency pumps, underground equipment, sweeping machines, winter operation equipment, emergency power generating units			250	500	125	250
Vehicle engines			Lube oil intervals in km		Lube oil intervals in km	
			Naturally aspirated engines		Turbocharged engines	
Lube oil quality	API classification		CC 1)	CD/CE 1)	CD/CE/CF-4	CF-4
	CCMC classification		—	D4	D4	D5 2) (SHPD) 3)
Service group	Annual kilometrage km	average speed approx. km/h				
I	to 30 000	20	10 000	20 000	5 000	10 000
II	more than 30 000 to 100 000	40	20 000	40 000	10 000	20 000
III	more than 100 000	60	30 000	60 000	15 000	30 000

Change the oil with the engine off but still warm (lube oil temperature approx. 80 °C).

¹⁾ Lube oils having both a C- and an S classification (e.g. CD / SE) can be used. Oils with only a C classification (e.g. CE) generally perform very well in diesel engines and are to be preferred.

²⁾ D5 grade oil with sulfate ash content > 1.8% by mass.

³⁾ SHPD lube oils can be used.

These are the equivalent of D5 grade.

- In the case of fuels containing more than 1% sulfur, contact your service representative.

6.1.2 Checking Oil Level/Changing Engine Oil

6.1.2.1 Checking Oil Level

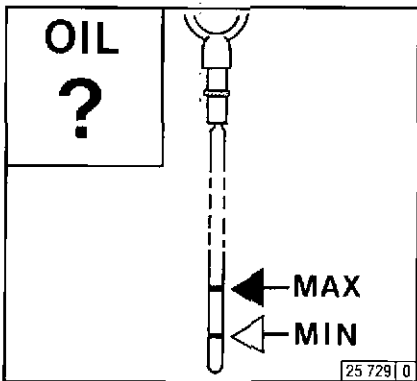

- Ensure that the engine or vehicle is in a level position.
- Remove the oil dipstick.
- Wipe the dipstick with a non-fibrous, clean cloth.
- Insert it to the stop and remove again.
- Check the oil level, and if necessary, top up to the "MAX" mark.
 - If the oil level is only just above the "MIN" mark, more oil must be added.

The oil level must not drop below the "MIN" mark.

6.1.2.2 Changing Engine Oil

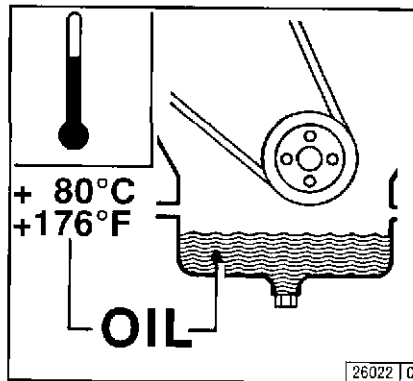

- Allow the engine to warm up.
- Ensure that the engine or vehicle is in a level position.
 - Lube oil temperature approx. 80 °C.
- Turn the engine off

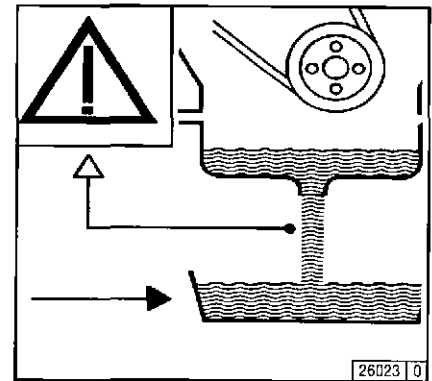

- Place oil tray under the engine.
- Unscrew drain plug.
- Drain oil.
- Fit oil drain plug, with the new gasket and tighten firmly (for torque, see 9.2)
- Pure in lube oil
 - For grade / viscosity, see 4.1
 - For quantity, see 9.1
- Check oil level, see 6.1.2.1.



Be careful when draining hot oil – danger of scalds!
Do not let used oil run into the soil but catch it in a container ready for proper disposal!

6.1.3 Changing Oil Filter

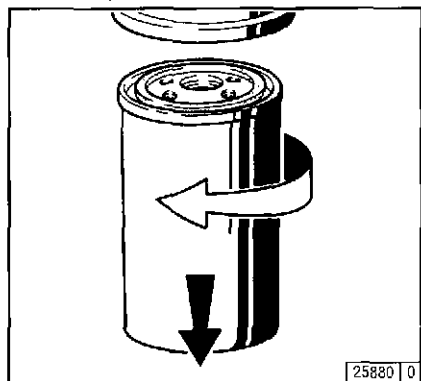

- Undo the filter cartridge using a commercial tool and spin off.
- Catch any dripping oil.

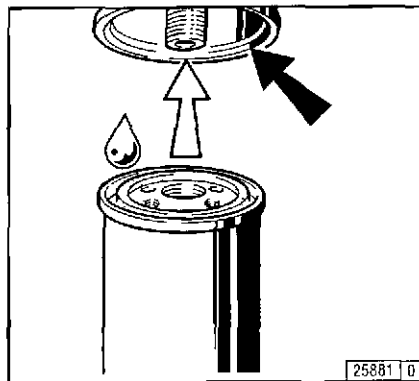

- Clean any dirt from the filter carrier rim.
- Lightly oil the rubber gasket of the new oil filter cartridge.
- Screw in the new cartridge finger tight against the gasket.

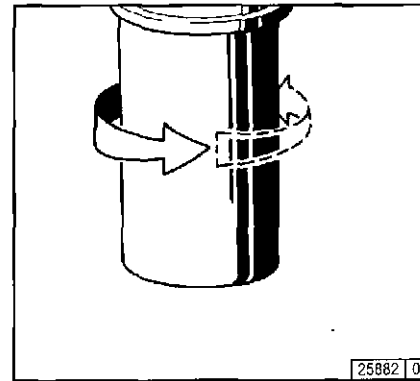

- Tighten the oil filter cartridge with another half-turn.
- Check oil level, see 6.1.2.
- Check oil pressure, see 3.3.1.
- Check cartridge seal for leaks.



Beware of burns from hot oil.

6.2.1 Changing Fuel Filter

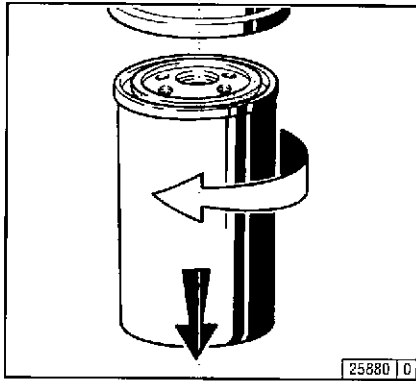

- Close fuel stopcock.
- Undo fuel filter cartridge with commercial tool and spin off.
- Catch any fuel.

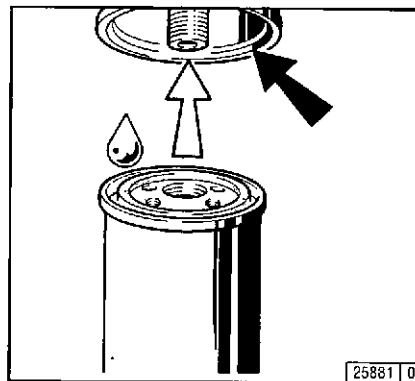

- Clean any dirt from the filter cartridge with a final half-turn.
- Apply light film of oil or diesel fuel to the rubber gasket of the new fuel filter cartridge.
- Screw in the new cartridge finger tight against the gasket.

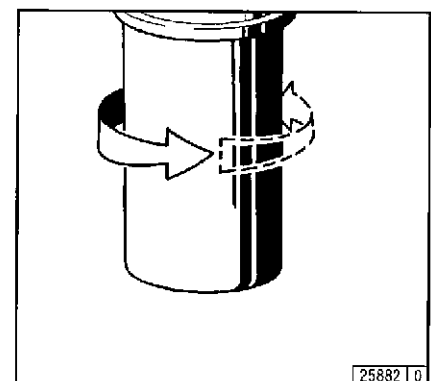

- Tighten the fuel filter cartridge with a final half-turn.
- Open fuel stopcock.
- Check for leaks.



Keep naked flames away when working on the fuel system. Do not smoke.

The fuel system does not need to be bled.

6.2.2 Fuel Pump Cleaning the Strainer

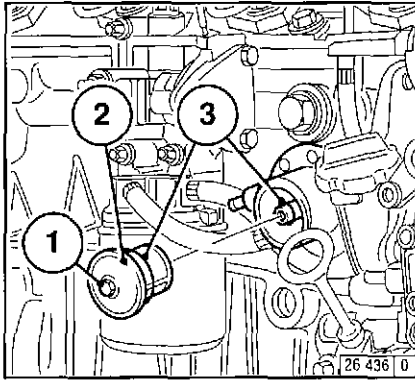

6

- Close the fuel shut-off valve.
- Loosen and unscrew the hexagonal nut 1.
- Remove the fuel strainer cover 2 (cover and strainer, one unit)
- Clean the fuel strainer with diesel fuel. Replace if necessary.
- Place seals 3 in position.
- Mount the fuel strainer cover 2.
- Tighten the hexagonal screw 1.
- Check for leaks.



Keep naked flames away when working on the fuel system.
Do not smoke!

6.3.1 Cleaning Intervals

- The amount of contamination in the cooling system depends on the engine application.
- Spilled oil or fuel on the engine increases the risk of contamination. Be especially careful if the engine is used in dusty environments.
- Serious contamination can occur, for example:
 - on construction sites where there is a high level of air-borne dust.
 - in harvesting application where there are high concentrations of chaff and chopped straw in the vicinity of the machine.
- Because applications vary, cleaning intervals have to be determined from case to case. The cleaning intervals given in the table on the right can be used as a guide.
- Clean the engine as described in 6.8.1.

Inspection and cleaning intervals Recommended OH	Engine application
2000	Ships, Electrical units in enclosed areas, pumps
1000	Vehicles on reinforced highways
500	Tractors, fork-lift trucks, mobile electrical units
250	Vehicles on construction sites and on roads with loose surfaces, construction machinery, compressors, mining equipment
125	Agricultural machinery, tractors used for harvesting purposes

6.4.1 Cleaning Intervals

- The amount of dirt in the air cleaner depends on the amount of dust in the air and the size of the air cleaner used. If a high level of dust is anticipated, a cyclone-type precleaner can be fitted to the air cleaner.
- Cleaning intervals will have to be determined from case to case.
- Air cleaner servicing is needed when:
 - **Service indicator**
the red signal 1 is fully visible when the engine is off.
 - **Service switch**
the yellow pilot light comes on when the engine is running.
- After carrying out service work, reset the signal by pressing the button on the service indicator.

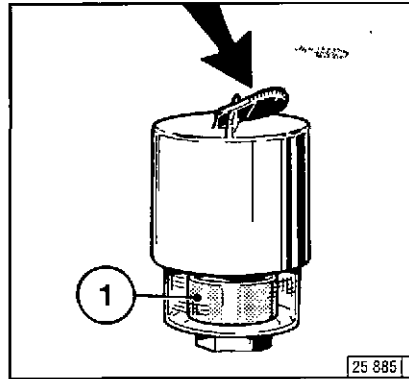

6.4.2 Emptying Cyclone Type Precleaner.

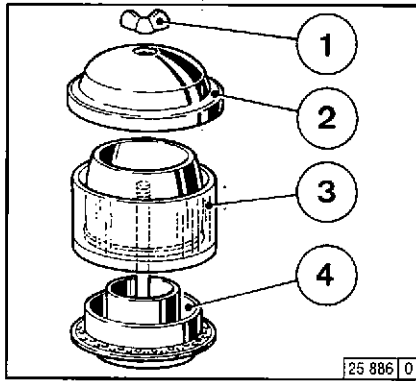

- Undo wing nut 1 and remove cover 2.
- Remove collector bowl 3 from lower section 4 and empty. Clean leaves, straw and other foreign matter from lower section of pre-cleaner.
- Reposition collector bowl 3 onto lower section 4, fasten cover 2 in place by tightening wing nut 1.

Never fill collector bowl with oil. Replace collector bowl if damaged.

6.4.3 Cleaning Oil Bath Air Cleaner

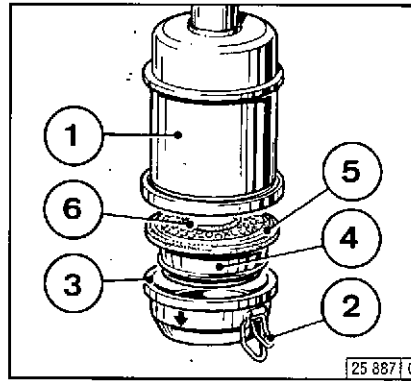

- Turn engine off and wait about 10 minutes for the oil to drain from filter housing 1.
- Release snap clips 2 and remove oil cup 3 together with filter element 4. If necessary prise element out with a screwdriver, taking care not to damage the rubber gasket 5.
- Remove dirty oil and sludge. Clean oil cup.
- Clean filter element 4 in diesel fuel and allow to drip-dry.

- Clean filter housing 1 if very dirty.
- Inspect and replace rubber gasket 5 and 6 if necessary.
- Fill oil cup with engine oil up to the mark (arrow) (for viscosity, see 4.1.2).
- Refit oil cup and element to filter housing and secure with snap clips.



Never clean air cleaner with gasoline. Dispose of cold oil in accordance with environmental regulations!

6.4.4 Dry Type Air Cleaner Dust Discharge Valve

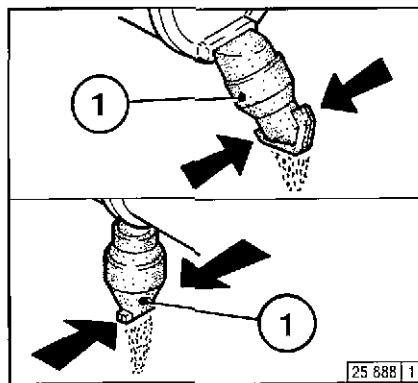

- Empty dust discharge valve 1 by pressing apart lips of discharge slot as indicated by arrows.
- Clean discharge slot from time to time.
- Remove any caked dirt by pressing together the upper section of the valve.

Filter Cartridge

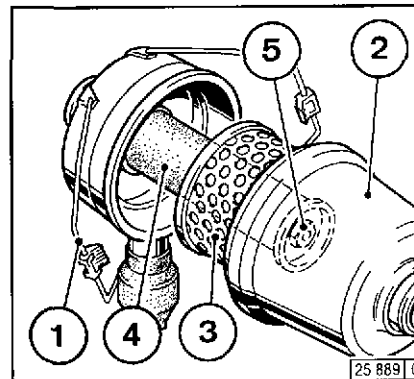

- Undo clip fasteners 1.
- Take off hood 2 and remove cartridge 3.
- Clean cartridge (replace at least once a year)
- Clean cartridge 3.
Blow out from inside out with dry compressed air (max. 5 bar), (or in difficult cases, tap out, taking care not to damage the cartridge, or wash according to manufacturer's instructions).
- Through regular removal and replacement, the gaskets on the filter cartridge can become damaged. Check paper filter (light showing through) and gaskets for damage. Replace if necessary.

- After five cleaner services or after two years at the latest, replace safety cartridge 4 (never clean).
To do so:
 - Undo hex. nut 5 and remove cartridge 4.
 - Install new cartridge, insert and tighten hex nut.
- Install cartridge 3, replace hood 2 and do up clip fasteners 1.



Never clean filter cartridge with gasoline or hot fluids.

6.5.1 Checking V-Belts

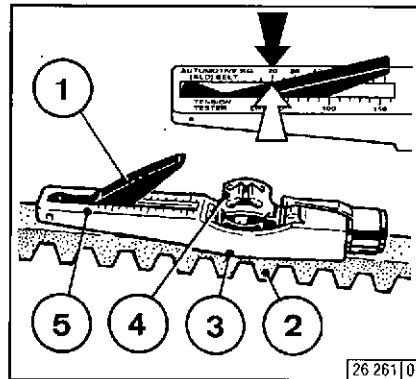
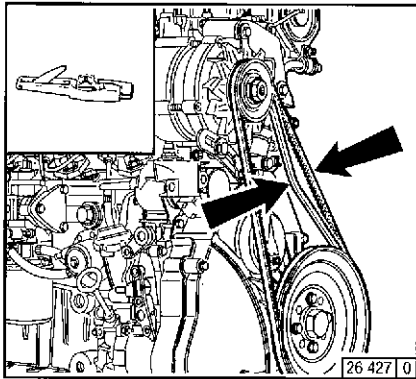

- Inspect entire V-belt for damage.
- Replace damaged V-belts.
- After installing new belts, run engine for 15 minutes, then check belt tension.
- To check the tension of the V-belt, use a tension gauge (see 9.3).
 - Place indicator arm 1 into gauge.
 - Position gauge on V-belt 2, midway between the pulleys, with flange 3 on bottom of gauge against the edge of belt.
 - Push slowly on the black pad 4 at right angles to belt 2 until the spring is heard or felt to trigger.

- Carefully remove the gauge without altering the position of the indicator arm 1.
- Read off the value where the black indicator arm 1 intersects scale 5 (arrow). For settings, see 9.1.
- If necessary, retension belt and measure again.



Check tension and change belts only with the engine off. Refit belt guard, if provided.

When new V-belts are fitted, check the belt tension after ca. 15 minutes running time.

6.5.2 Tensioning Alternator Belts

6.5.3 Changing Alternator Belts

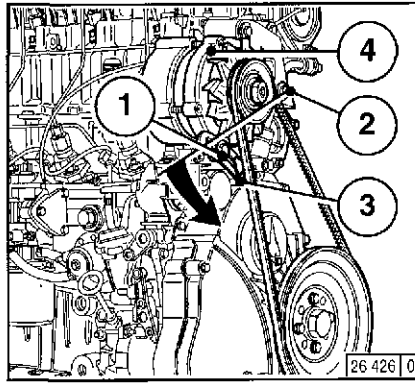
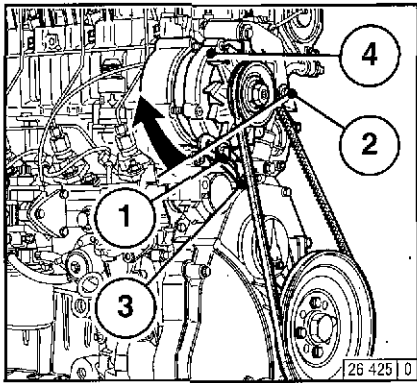

6

- Slacken off bolts 1, 2 and 3.
- Adjust alternator 4 in direction of arrow by turning bolt 3 until correct belt tension is achieved.
- Retighten bolts 1, 2 and 3.

- Slacken off bolts 1, 2 and 3.
- Adjust alternator 4 in direction of arrow by turning bolt 3.
- Remove and replace belt.
- Adjust alternator 4 against the direction of the arrow by turning bolt 3, until correct belt tension is achieved.
- Retighten bolts 1, 2 and 3.



Check, tension and change belts only with the engine off. Refit belt guard, if provided.

6.6.1 Checking / Adjusting Valve Clearances

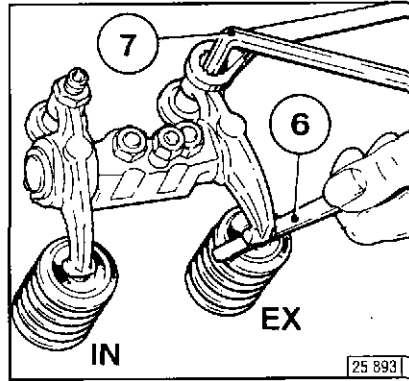
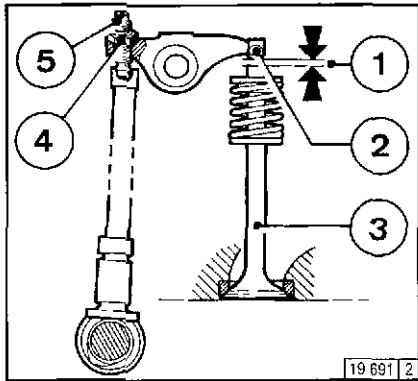

6

- Remove the cylinder head cover.
- Position crankshaft as per schematic 6.6.1.1.
- Before adjusting valve clearance, allow engine to cool down for at least 30 minutes. The oil temperature should be below 80 °C.
- Check valve clearance 1 between rocker arm / tappet contact face 2 and valve stem 3 with feeler gauge 6 (there should be only slight resistance when feeler blade is inserted).
For permissible valve clearance, see 9.1.

- Adjust valve clearance if necessary:
 - Release locknut 4.
 - Use alien key 7 to turn setscrew 5 so that the correct clearance is attained after locknut 4 has been tightened.
- Check and adjust valve clearance on all remaining cylinders.
- Replace cylinder head cover (use new gasket if needed).

6.6.1.1 Valve Clearance Adjustments Schematic

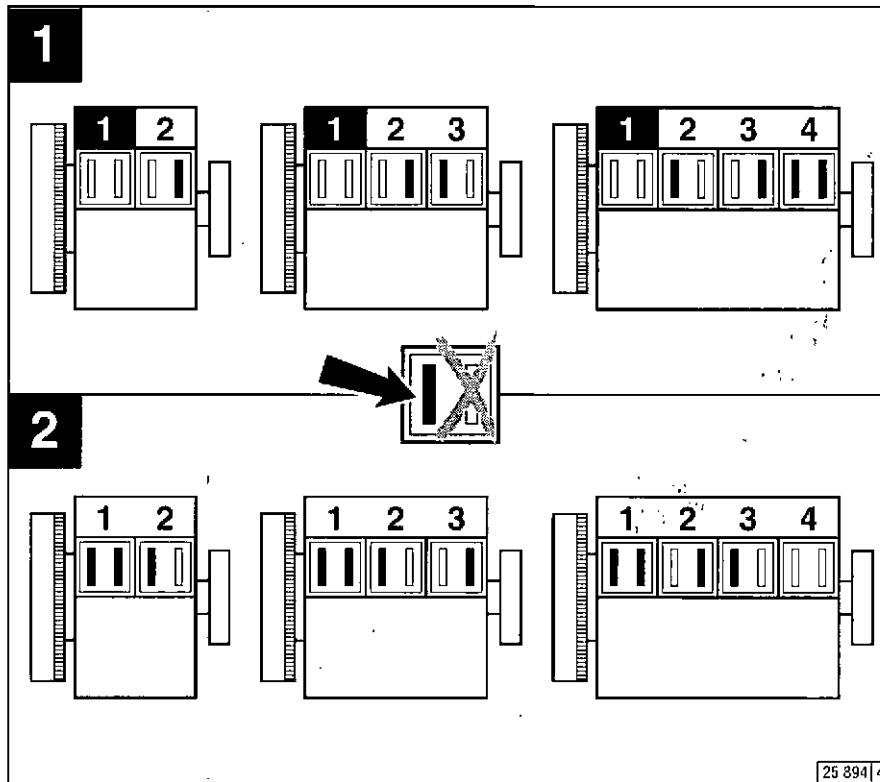

● **Crankshaft Position 1:**
Turn crankshaft until both valves in cylinder 1 overlap (exhaust valve about to close, inlet valve about to open). Adjust clearance of valves **marked in black** on schematic. Mark respective rocker arm with chalk to show that adjustment has been done.

● **Crankshaft Position 2:**
Turn crankshaft one full revolution (360°). Adjust clearance of valves **marked in black** on schematic.

6.7.1 Battery

6.7.1.1 Checking Battery and Cable Connectors

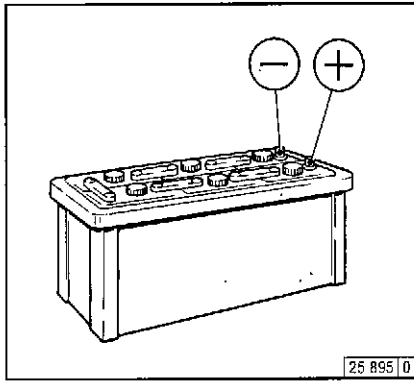

25 895 | 0

6.7.1.2 Checking Electrolyte Level

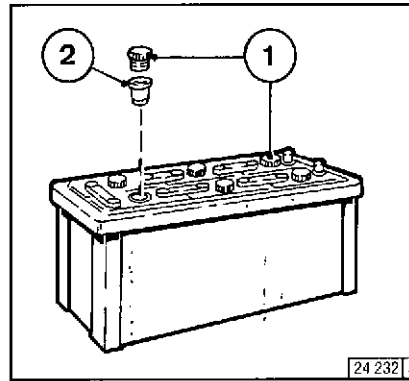

24 232 | 3

6.7.1.3 Checking Electrolyte Density

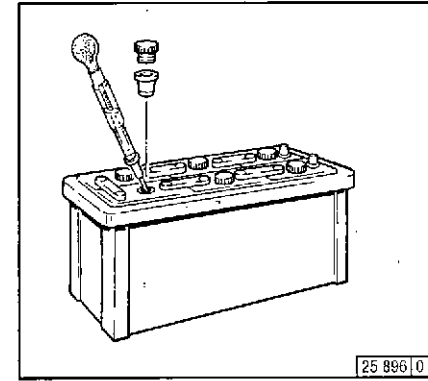

25 896 | 0

6

- Keep battery clean and dry.
- Undo dirty clamps.
- Clean terminal posts (+ and -) and clamps of the battery, and grease with acid-free and acid-resistant grease.
- When reassembling, ensure that clamps make good contact. Do up clamp bolts finger tight.

- Remove caps 1.
- If testers 2 are used, the electrolyte should come up to their base.
- If testers are not used, the electrolyte level should be 10-15 mm above the top of the plates.
- If necessary, top up with distilled water.
- Replace caps.

- Measure the electrolyte density of individual cells with a commercial hydrometer.

The hydrometer reading (see table on following page) indicates the state of charge. During measurement, the temperature of the electrolyte should preferably be 20 °C.

Electrolyte density				
in kg/l		in ° Bé (Baumégrad) *		State of Charge
Normal	Tropics	Normal	Tropics	
1.28	1.23	32	27	Fully charged
1.20	1.12	24	16	Half charged, recharge
1.12	1.08	16	11	Discharged, recharge immediately

* Measurement of electrolyte density in ° Bé (Baumégrad) is out of date and rarely used today.



The gases emitted by the battery are explosive! Keep sparks and naked flames away from the battery. Do not allow battery acid to come into contact with skin or clothing.

Wear protective goggles. Do not rest tools on the battery.

6.7.2 Three-Phase Alternator

6.7.3 Lifting Tackle

Notes on the three-phase system:

- Never disconnect the cables between battery, alternator and regulator while the engine is running.
- If, however, it is necessary to start and operate the engine without the battery, disconnect the regulator from the alternator before starting.
- Be sure not to confuse the battery terminals.
- Replace defective bulb of the charge pilot lamp immediately.
- When washing the engine, cover up the alternator and regulator.
- The habit of touching a lead against the frame to check whether it is live must under no circumstances be used with three-phase electrical systems.
- In case of electric welding, connect the ground terminal on the welder directly to the piece being welded.

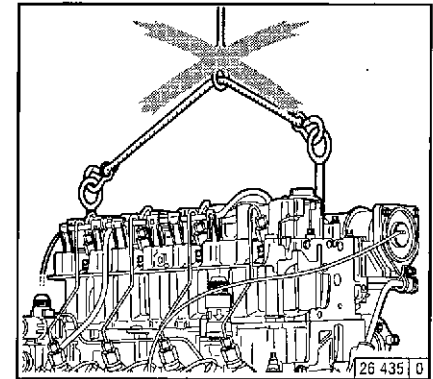
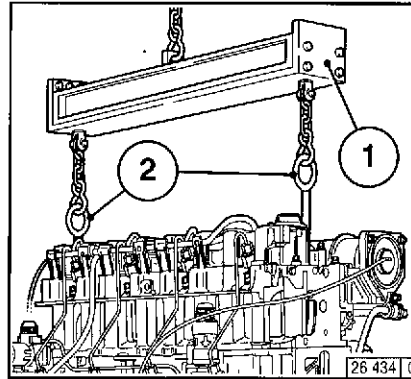

- Always use proper lifting tackle 1 when transporting the engine.
- After transportation and before commissioning of the engine:
Remove attachment eyes 2.



Use only the correct lifting tackle.

6.7.4 Ether Starting System

6.7.4.1 Changing the Fluid Container

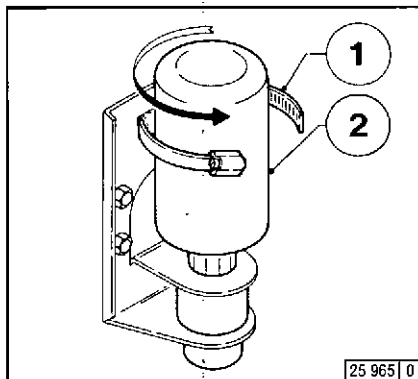

- Before removing the container, clean the container support and the top of the solenoid valve.
- Loosen the bracket 1.
- Unscrew the fluid container 2.
- Empty or replace the depressurized fluid container.

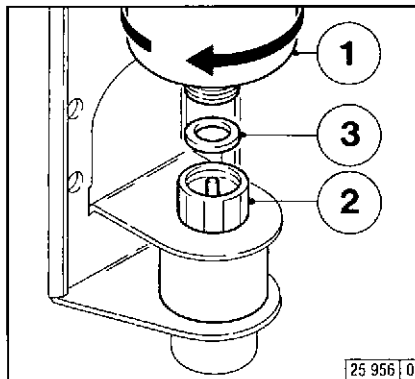

- Place the container 1 on the solenoid valve 2 and tighten by hand.
- When mounting, ensure that gasket 3 is seated correctly.
- Pull in the brackets.
- Check for leaks.



Before commissioning, leave the fluid container of the ether starting system in position for 15 minutes. Check for leaks. The starting fluid is inflammable. Ensure that the container is not damaged. Prevent foreign substances from entering the container. The fluid container must not be stored at temperatures above 50 °C.

6.8.1 Engine Cleaning

Preparation

- Switch off the engine.
- Remove engine covers and cooling air hood.
Replace them after cleaning and before the test run.
- Cover electrical / electronic components / connections (eg. generator, starter, governor, solenoid).

Using compressed air

- Blow air through the engine, taking particular care not to damage the cooler and cooling fins (begin to blow through air from the exhaust side).
Remove the dirt which has blown into the interior space.

Using cold-cleaning compound

- Spray the engine with the commercial cold-cleaning compound and allow to react for approx. 10 mins.
- Spray clean the engine with a strong water jet, repeat if necessary.
- Allow the engine to run up so that the remaining water evaporates.

Using high pressure device

- Clean the engine with a steam jet (max. spray pressure of 60 bar, max. steam temperature of 90°C).
- Allow the engine to run up so that the remaining water evaporates.

6



Clean the engine only when the engine is switched off.

7.1 Diagnosis Chart

- Faults are often caused by maloperation of the engine or failure to service the engine.
- In the event of a fault, always check whether the operating and servicing regulations have been adhered to.
- A corresponding fault table can be found on the adjacent page.
- If you cannot ascertain the cause of a fault or cannot rectify the fault, please contact DEUTZ SERVICE.

Fault		Remedy	
Engine fails or is difficult to start		Check	P
Engine starts but runs unevenly or stalls		Adjust	E
Engine overheats. Temperature monitor gives warning		Replace	W
Engine gives poor performance		Clean	R
Engine not firing on all cylinders		Top up	A
Engine has little or no oil pressure		Lower level	S
Engine oil consumption excessive			
Engine smokes - blue			
- white			
- black			
Cause		Section	
●	Not declutched (where possible)	Operation	P
●	Below starting limit temperature		P
	Oil level too low		A
	Oil level too high		P
	Excessive inclination of engine		S
●	Incorrect lube oil SAE class or quality	Operating media	W
● ●	Fuel quality not as per operating manual		W
	Air cleaner clogged / turbocharger defective	Combustion air	P / W
	Air cleaner service switch / indicator defective		P / W
	LDA* defective		P
	Charge air line leaking		P
	Oil cooler panels clogged	Cooling system	P / R
	Cooling fan defective, split or loose V-belt		P / W
	Cooling air temperature rise / heating short circuit		P
	Resistance in cooling system too great / through-flow quantity too small		P
●	Battery defective or discharged	Electrics	P / A

* LDA = Aneroid device

Fault										Remedy		
Engine fails or is difficult to start										Check	P	
Engine starts but runs unevenly or stalls										Adjust	E	
Engine overheats. Temperature monitor gives warning										Replace	W	
Engine gives poor performance										Clean	R	
Engine not firing on all cylinders										Top up	A	
Engine has little or no oil pressure										Lower level	S	
Engine oil consumption excessive												
Engine smokes – blue												
– white												
– black												
Cause										Section		
●										Electric cable connections to starter electrical system loose or oxidized	Electrics	P
●										Starter defect or pinion does not engage		P
●										Solenoid defective (release switch)		P
●	●		●			●	●			Incorrect valve clearance	Engine	E
●	●	●	●	●						Leaking injection line		P
●	●	●	●	●		●	●			Injection valve defective		P / W

8.1 Preservation

8.1.1 Preserving Engine

If the engine is to remain idle for an extended period of time, it is necessary to take protective measures to prevent rust formation. The preservative measures described here will protect the engine for up to 6 months. The procedure will have to be reversed before the engine is recommissioned.

- Anti-corrosion oils to specification:
MIL-L-21260B
TL 9150-037/2
Nato Code C 640 / 642
- Anti-corrosion media for exterior protection only to specification:
Nato Code C 632
- Recommended cleansing agent to remove preservatives when recommissioning engine:
Petroleum benzine
(hazardous materials class A3)

- Clean engine (with cold cleansing agent if preferred) using high pressure equipment.
- Run engine until warm, then turn off.
- Drain engine oil, see 6.1.2, and fill with anti-corrosion oil.
- If necessary, clean oil bath cleaner, see 6.4.3, and fill with anti-corrosion oil.
- Drain fuel tank.
- Make up a mixture of 90 % diesel fuel and 10 % anti-corrosion oil, and refill fuel tank.
- Run engine for about 10 minutes.
- Turn engine off.
- Turn engine over manually several times to preserve the cylinders and combustion chamber.
- Remove V-belts and store in wrapped condition.
- Spray grooves on V-belt pulleys with anti-corrosion spray.
- Close off intake ports and exhaust ports.

8.1.2 Removing Engine Preservatives

- Remove anti-corrosion agent from grooves in V-belt pulleys.
- Install V-belts. Retension after brief operation if necessary, see 6.5.
- Remove covers from intake port and exhaust port.
- Set the engine in operation, see also section 5.1, annotation 2.

9.1 Engine Specifications and Settings

9.2 Torque Wrench Settings

9.3 Tools

Model

		F2L 1011F	F3L 1011F	F4L 1011F
Numbers of cylinders		2	3	4
Cylinder arrangement		vertical in line		
Bore	[mm]	91		
Stroke	[mm]	105		
Total displacement	[cm ³]	1366	2049	2732
Compression ratio	[ε]	18,5		
Working cycle		4-stroke diesel engine		
Combustion system		naturally aspirated engine with direct injection		
Direction of rotation		counter clockwise		
Weight incl. integrated cooling system as per DIN 70020-A (without starter, with alternator)	ca. [kg]	167	208 ¹⁾	249,5
Engine power	[kW (PS)]	1)		
Speed	[1/min]	1)		
Lubrication		pressure lubrication		
SAE oil		20 W 20		
Max. oil temperature in oil sump	[°C]	130		
Min. oil pressure in warm condition, oil temperature 110 °C at: 900/min (low idling speed)	[bar]	1,4 ³⁾		
1800 /min	[bar]	2,2 ³⁾		
max. 3300 /min	[bar]	3 ³⁾		
Oil change quantity (oil sump) ca.	[ltr.]	6 ²⁾	5,5 ²⁾	10 ²⁾
Oil change quantity with filter (Standard 0.5 ltr.) ca.	[ltr.]	6,5 ²⁾	6 ²⁾	10,5 ²⁾
Valve clearance with cold engine	[mm]	inlet 0.3		
(Engine cooling time at least 30 Min.: Oil temperature below 80°C)	[mm]	exhaust 0.5		
Start of delivery	[°crank angle b TDC]	1)		
Injector opening pressure: vehicle/genset engine	[bar]	210 / 250 ⁺⁸		
Firing order of the engine		1 - 2	1 - 2 - 3	1 - 3 - 4 - 2
V-Belt tension: Pretension / Retension (after the engine has been running under load for 15 mins):[N]		400 / 300 ±20		

9

¹⁾ Engine power, speed, start of delivery are stamped on engine rating plate, see also 2.1.

²⁾ Ca. value can vary depending on model. **The upper oil dipstick marking should always be taken as authoritative.**

³⁾ Values for engines without engine oil heating.

Model

Number of cylinders	
Cylinder arrangement	
Bore	[mm]
Stroke	[mm]
Total displacement	[cm ³]
Compression ratio	[ε]
Working cycle / Combustion system	
Direction of rotation	
Weight without cooling system	[kg]
Weight without starter, with alternator as per DIN 70020-A ca.	[kg]
Engine power	[kW (PS)]
Speed	[1/min]
Lubrication	
SAE oil	
Max. oil temperature in the oil sump	[°C]
at: 900/min (low idling speed)	[bar]
1800 /min	[bar]
max. 3000 /min	[bar]
Oil change quantity (oil sump without cooling system) ca.	[ltr.]
Oil change quantity with filter (Standard 0.5 ltr.) ca.	[ltr.]
Valve clearance with cold engine (Engine cooling time at least 30 mins.: oil temperature below 80°C)	[mm]
Injector opening pressure: vehicle/genset engine	[bar]
Start of delivery	[°crank angle b TDC]
Firing order of the engine	
V-Belt tension: Pretension / Retension (after the engine has been running under load for 15 mins):[N]	

BF4L 1011F/FT	
Number of cylinders	4
Cylinder arrangement	vertical in line
Bore	91
Stroke	105
Total displacement	2732
Compression ratio	17
Working cycle / Combustion system	4-stroke diesel with turbocharging and direct injection
Direction of rotation	counter clockwise
Weight without cooling system	Refer to head-office
Weight without starter, with alternator as per DIN 70020-A ca.	256,5
Engine power)
Speed)
Lubrication	
SAE oil	20 W 20
Max. oil temperature in the oil sump	130
at: 900/min (low idling speed)	1,4 ³⁾
1800 /min	2,2 ³⁾
max. 3000 /min	3 ³⁾
Oil change quantity (oil sump without cooling system) ca.	10 ²⁾
Oil change quantity with filter (Standard 0.5 ltr.) ca.	10,5 ²⁾
Valve clearance with cold engine (Engine cooling time at least 30 mins.: oil temperature below 80°C)	inlet 0,3 + 0,1 / exhaust 0,5 + 0,1
Injector opening pressure: vehicle/genset engine	210 / 250 + ^a
Start of delivery)
Firing order of the engine	1-3-4-2
V-Belt tension: Pretension / Retension (after the engine has been running under load for 15 mins):[N]	400 / 300 ±20

¹⁾ Engine power, speed, start of delivery are stamped on engine rating plate, see also 2.1.

²⁾ Ca. value can vary depending on oil sump and or cooler design (external cooling system). **The upper oil dipstick marking should always be taken as authoritative.**

³⁾ Values for engines without engine oil heating.

Model

Number of cylinders	
Cylinder arrangement	
Bore	[mm]
Stroke	[mm]
Total displacement	[cm ³]
Compression ratio	[ε]
Working cycle	
Combustion system	
Direction of rotation	
Weight without cooling system (without starter, with generator) ca.	[kg]
Engine power	[kW (PS)]
Speed	[1/min]
Lubrication	
SAE oil	
Maximum oil temperature in the oil sump	[°C]
Minimum oil pressure in warm condition, oil temperature 110 °C, at: 900/min (low idling speed)	[bar]
1800 /min	[bar]
max. 3000 /min	[bar]
Engine with Thermostat	
Oil change quantity without external cooler (see 3.1.1.2)/ without filter approx.	[ltr.]
Oil change quantity without external cooler (see 3.1.1.2) + filter replacement (Standard 0.5 litre) approx.	[ltr.]
Genset engine without Thermostat:	
Oil change quantity including cooler (see 3.1.1.3)/ without filter approx.	[ltr.]
Oil change quantity including cooler (see 3.1.1.3) + filter replacement (Standard 0.5 litre) approx.	[ltr.]
Valve clearance at cold engine (Engine cooling time at least 30 mins.: oil temperature below 80°C)	[mm]
Start delivery	[°crank angle b TDC]
Injector opening pressure: vehicle/genset engine	[bar]
Firing order of the engine	
V-Belt tension: Pretension / Retension (after the engine has been running under load for 15 mins):[N]	

F3M 1011F	F4M 1011F
3	4
vertical in line	
91	
112	112
2184	2912
18.5	
4-stroke diesel engine	
naturally aspirated engine with direct injection	
counter clockwise	
200	242,5
1)	
1)	
pressure lubrication	
20 W 20	
130	
1,4 ³⁾	
2,2 ³⁾	
3 ³⁾	
5,5 ²⁾	10 ²⁾
6 ²⁾	10,5 ²⁾
8,5 ²⁾	13 ²⁾
9 ²⁾	13,5 ²⁾
inlet 0,3 ^{+0,1} / exhaust 0,5 ^{+0,1}	
210 / 250 ^{*8}	
1 - 2 - 3	1 - 3 - 4 - 2
400 / 300 ±20	

¹⁾ Engine power, speed, start of delivery are stamped on engine rating plate, see also 2.1.

²⁾ Ca. value can vary depending on oil sump and or cooler design (external cooling system). **The upper oil dipstick marking should always be taken as authoritative.**

³⁾ Values for engines without engine oil heating.

Model

Number of cylinders	
Cylinder arrangement	
Bore	[mm]
Stroke	[mm]
Total displacement	[cm ³]
Compression ratio	[ε]
Working cycle	
Combustion system	
Direction of rotation	
Weight without cooling system (without starter, with generator) ca.	[kg]
Engine power	[kW (PS)]
Speed	[1/min]
Lubrication	
SAE oil	
Maximum oil temperature in the oil sump	[°C]
Minimum oil pressure in warm condition, oil temperature 110 °C, at: 900/min (low idling speed)	[bar]
1800 /min	[bar]
max. 2800 /min	[bar]
Engine with Thermostat	
Oil change quantity without external cooler (see 3.1.1.2)/ without filter approx.	[ltr.]
Oil change quantity without external cooler (see 3.1.1.2) + filter replacement (Standard 0.5 litre) approx.	[ltr.]
Genset engine without Thermostat:	
Oil change quantity including cooler (see 3.1.1.3)/ without filter approx.	[ltr.]
Oil change quantity including cooler (see 3.1.1.3) + filter replacement (Standard 0.5 litre) approx.	[ltr.]
Valve clearance at cold engine (Engine cooling time at least 30 mins.: oil temperature below 80°C)	[mm]
Start delivery	[°crank angle b TDC]
Injector opening pressure: vehicle/genset engine	[bar]
Firing order of the engine	
V-Belt tension: Pretension / Retension (after the engine has been running under load for 15 mins.):[N]	

BF4M 1011 F	
	4
	vertical, in line
	91
	112
	2912
	17
	4-stroke diesel
	turbocharging and direct injection
	counter clockwise
	Refer to head-office
	249,5
	1)
	1)
	pressure lubrication
	20 W 20
	130
	1,4 ³⁾
	2,2 ³⁾
	3 ³⁾
	10
	10,5
	13,5
	14
	inlet 0,3 ^{+0.1} / exhaust 0,5 ^{+0.1}
	1)
	210 / 250 ⁺⁸
	1-3-4-2
	400 / 300 ±20

¹⁾ Engine power, speed, start of delivery are stamped on engine rating plate, see also 2.1.

²⁾ Ca. value can vary depending on oil sump and or cooler design (external cooling system). **The upper oil dipstick marking should always be taken as authoritative.**

³⁾ Values for engines without engine oil heating.

Location	Preload [Nm]			Torquing Load [Nm]				Total [Nm]	Remarks
	1st Stage	2nd Stage	3rd Stage	1st Stage	2nd Stage	3rd Stage	4th Stage		
Rocker cover								8.5	
Rocker arm set screw								21	
Air intake manifold								21	
Exhaust manifold								40	
Oil drain plug								55	
Injector mounting								21	TORX
Injector line mounting								22	
Oil pan (cast iron)								31	
Oil pan (sheet metal)								21	

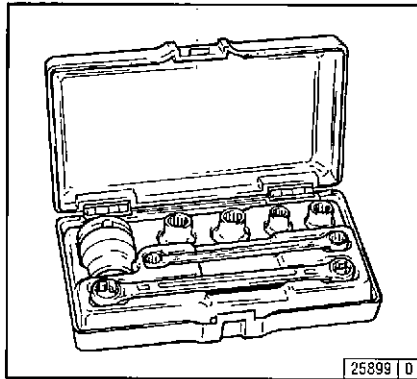
TORX

25899 | 0

A TORX wrench set is used with engines in the 1011 series, Order No. 8189. This system was chosen because of the many advantages it offers:

- Outstanding accessibility to bolts.
- High load transfer when loosening and tightening.
- Almost impossible for socket to slide off or break.

TORX tools can be ordered from:

COMPANY WILBÄR
Postfach 14 05 80
D-42826 Remscheid

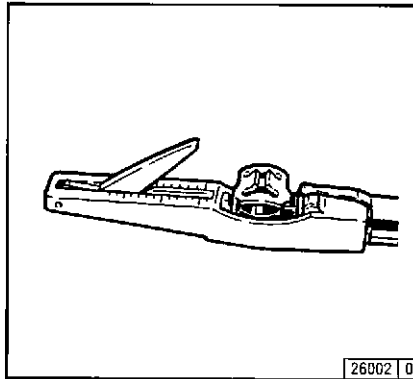
V-belt Tension Gauge

26002 | 0

The V-belt tension gauge can be obtained under order number **91 107** from:

COMPANY WILBÄR
Postfach 14 05 80
D-42826 Remscheid

DEUTZ SERVICE INTERNATIONAL GmbH
Deutz-Mülheimer Str. 107
Postfach 80 05 09
D-51057 Köln

Region!		Germany Austria Switzerland East Europe	North-, West-, Southeurope North America Asia Australia	South America Algeria Africa Greece, Turkey
Sales service products	Telephone	(0221) 822 5247/ 5281	(0221) 822 5224	(0221) 822 5245
	Telefax	(0221) 822 3674/ 822 5462		(0221) 822 2909
	Telex	8812 253 KHD D		
Order processing	Telephone	(0221) 822 5580/ 5556	(0221) 822 5557/ 2737	(0221) 822 5559
	Telefax	(0221) 822 2700/ 822 5304/ 822 2665		
	Telex	8812 251 KHD D		
Service Engineering DEUTZ	Telephone	(0221) 822 3209		
	Telefax	(0221) 822 3204		
	Telex	8812 241 KHD D		

Give us a ring and we furnish you with the address of the DEUTZ SERVICE INTERNATIONAL GmbH outpost nearest to your facility.
 A "SERVICE REGISTER WORLD" can be ordered under No. 0297 7099
 A "List of Service Documentation WORLD" can be ordered under No. 0297 5198

SERVICE Phone for technical questions: (0221)822 5454
 Direct dial from 8.00 a.m. to 5.00 p.m.
 At night, on weekends and holidays automatic phone answerer.
 (We shall responds the next working day.)

Impressum:

DEUTZ SERVICE INTERNATIONAL GmbH

Deutz - Mülheimer Straße 107

P.O. Box 80 05 09

D - 51057 Köln

Phone (0221) 822 - 0

Telex 8812 - 0 khd d

Fax (0221)822 - 5358

Printed in Germany

Contents and Layout

Service Documentation AZ-TD

All rights reserved

5th Edition, 04/96

Circulation 10 000 copies

Order No. 0297 7118 en

(05.96)