

MAINTENANCE MANUAL G4800



HERCULES
ENGINE COMPANY

40-0090228

Engine Specialists Since 1915

I N T R O D U C T I O N

The Hercules G4800 series Natural Gas engines consists of three six cylinder models, natural aspirated, turbocharged, and turbocharged with after cooling. All are overhead valve, four cycle, heavy-duty commercial type engines. The engines are built as vertical engines (piston motion in a vertical plane). Extensive tests, both laboratory and field, have proven that these engines are adaptable to purposes for which such sizes and types are required.

All locations given as right-hand (R.H.) or left-hand (L.H.) have reference to the observer's position when facing the flywheel or clutch. The front of the engine is the timing gear end. The flywheel and clutch end is the rear of the engine. Therefore, when reference is made to No. 1 cylinder or front main bearing, it is always the one nearest the timing gears. Cylinders, connecting rod, etc., are numbered from the front or timing gear end of the engine. All dimensions are given in inches and fractions of inches, except as otherwise noted. All weights and measures are in United States avoirdupois or liquid measure standards.

This book is divided into the following sections, which appear in the order named Specifications, Operation, Lubrication, Description and Maintenance, Trouble Shooting, Fits and Tolerances.

When necessary to refer to accessories which are not furnished by Hercules Engines, Inc., information and comments given are general and may not apply to the specific accessory used.

As an operator, you owe it to yourself to read this book carefully.

GENERAL INDEX

SECTION	PAGE	SECTION	PAGE
AIR FILTERS OR CLEANERS		MAIN BEARINGS	
ALTERNATOR		MANIFOLD	
		MAJOR TUNE-UP	
BELLHOUSING		OPERATION	
BREATHER		OIL FILTER	
		OIL PAN	
CAMSHAFT		OIL PRESSURE	
COLD WEATHER STARTING		OIL PUMP	
CONNECTING RODS		OIL SEAL	
COOLING SYSTEM (WATER)		OPERATING INSTRUCTION	
COOLING SYSTEM(TURBO- AFTERCOOLER)		AFTER STARTING	
CRANKCASE AND CYL. BLOCK			
CRANKSHAFT		PISTON	
CYLINDER HEAD		PISTON PIN	
CYLINDER SLEEVES		PISTON RING	
		PRECAUTIONS	
DESCRIPTION & MAINTENANCE		PRELUDE TO OPERATION	
DAMPER-VIBRATION		PREPARING THE ENGINE FOR STARTING AFTER A LONG SHUTDOWN	
		PREVENTIVE MAINTENANCE SCHEDULE	
ELECTRICAL SYSTEM			
		SPECIFICATIONS	
FAN ASSEMBLY		STARTING AND OPERATING SUGGESTIONS	
FIRST TIME STARTING ENGINE		STARTING MOTOR	
FITS AND TOLERANCES		STARTING MOTOR	
FLYWHEEL		STARTING THE ENGINE	
FUEL SYSTEM		STOPPING THE ENGINE	
		STORING THE ENGINE(LONG PERIODS)	
GEAR HOUSING		THERMOSTAT AND BY-PASS	
GENERAL DESCRIPTION & FEATURES		TROUBLE SHOOTING	
GOVERNOR		TURBOCHARGER	
HIGH ALTITUDE OPERATION		USUAL ROUTINE WAY OF STARTING THE ENGINE	
INSPECTION OR ADJUSTMENTS			
LUBRICATING OIL <i>extended change</i>		VALVES	
LUBRICATION INSTRUCTIONS		VALVE GRINDING	
		VALVE SEAT REPLACEMENT	
		VALVE TAPPETS	
		WATER PUMP & FAN ASSY.	



HERCULES ENGINES, INC.

HERCULES ENGINES, INC.

LUBRICATING OIL FOR NATURAL GAS (NG) ENGINES.

Lubricating oil recommendations are based on engine design, type of service, and ambient air temperature. High quality oils combined with necessary oil and filter changes are required to assure maximum performance, long engine life and minimum operating cost. Hercules Engines NG fueled engines require oils formulated with additives specifically for NG engine operating conditions. It is acceptable to use a multigrade oil for operation during winter when ambient temperatures average below 30°F. However when average temperature is above 30°F, our turbocharged engines will have best life expectancy when a single grade (SAE 30 preferred) oil is used. The attached lists examples of oils which meet Hercules Engines requirements. For oils not listed, acceptable products must be designated for natural gas fueled engines and have a maximum sulfated ash content of 0.5% by weight. An excellent reference for selecting lub oils is the "EMA Lubricating Oils Data Book" which is available from:

Engine Manufacturers Association
One Illinois Center
111 East Wacker Drive
Chicago, IL. 60601

We strongly suggest that an oil sampling and analysis program be implemented for new applications to provide information necessary to select optimum oil/filter change intervals.

**ENGINE TIMING CHART
(SPARK IGNITED)**

ENGINES TIMED AT 1800 RPM

When using the charts below for correct timing to type of fuel used, set the engine speed at 1800 rpm. Using a timing light, align the degree mark with the center of the timing hole in the bellhousing, or pointer located on the front gear housing with the appropriate mark on the front pulley. Degrees shown are before top dead center of #1 piston compression stroke.

G4800 SERIES

FUEL	C RATIO	P/N	VENDOR	TIMING	RPM	PLUG GAP
LPG-NA	10:1	40-2505206	ALTRONIC	12°	1800	.015
NG-NA	10:1	40-2505206	ALTRONIC	18°	1800	.015
GTA-NG	10:1	40-2505210	ALTRONIC	20°	1800	.015
GTA-LPG	10:1	40-2505210	ALTRONIC	14°	1800	.015



HERCULES ENGINES, INC.

LUBRICATING OILS FOR HERCULES NATURAL GAS ENGINES

Based on information published in the "EMA Lubricating Oils Data Book", the following listed products meet Hercules Engines requirements for low ash level (<0.5% max.). Note that this list is not meant to be all inclusive.

Single viscosity (SAE Grade 30) for operation in average ambient temperatures above 30°F.

<u>COMPANY</u>	<u>BRAND</u>
Archer Petroleum	GLP
Caterpillar Inc.	CAT NCEO
Chevron	Chevron Gas Engine
Citgo	Citgo Pacemaker Gas Engine 800
Conoco	El Mar 3000/El Mar Ashless
Esso Petroleum	Essolube G30
JI Case	Case IH Low Ash Engine
Mobil Oil	Mobil Pegasus 390
Petro-Canada	Sentinel 435
Phillips	HDG
Shell	Shell Mysella
Sun Refining	Sunoco SEO 683
Texaco	Geotex LA
Troco Oil Co.	Geo-Guard 300
West Penn Oil Co.	Emblem Low Ash Gas Engine

Multigrade for operation at ambient temperature range as follows:

10 W 30	Minus 10°F to 50°F
15 W 40	Zero °F to 60°F
20 W 40	10°F to 60°F

<u>COMPANY</u>	<u>BRAND</u>	<u>SAE GRADE</u>
Esso Petroleum	Essolube G10W30	10W30
Esso Petroleum	Essolube G15W40	15W40
Phillips	HDG	20W40
Shell	Mysella Multigrade	10W40
Sun Refining	Sunoco SEO Ashless	15W40
Texaco	GEOTEX LA	20W40
Troco Oil Co.	GEO-Guard 300	15W40
Tenneco	Low Ash GEO 2030	15W30
West Penn Oil Co.	Emblem Low Ash Gas Engine	15W40

FUEL SYSTEMS GASEOUS

Gas engines can be designed to operate on various gaseous fuels, including natural gas, HD-5 propane, digester (sewage) gas, and landfill gas.

Each engine installation must be designed with a particular fuel in mind, because the octane rating and Btu content of different fuels can vary greatly (See Table 15-1). A gas analysis should be submitted to the engine manufacturer if a non-commercial grade fuel is to be used.

FUEL SPECIFICATIONS

TYPE OF FUEL	OCTANE RATING	BTU/FT LHV
Natural Gas	115-120	900
HD-5 Propane	95	2400
Digester Gas	115-120	600
Landfill Gas	115-120	400-450

NATURAL GAS ENGINES

Natural gas engines are often used for prime power applications. Generally the gas is supplied by utility owned lines that run to the installation site. The major components in the natural gas fuel system are the pressure regulators, piping and the carburetor (see Figure 15-1).

PRESSURE REGULATORS.

Pressure regulators (see Figure 15-2) are designed to control the pressure of the gas as it enters the engine. Through an arrangement of a diaphragm and springs, the pressure of the natural gas coming to the engine is lowered and controlled. This provides a steady supply of gas to the carburetor.

The fuel system uses a high pressure line regulator, mounted in the main fuel line, and a low pressure engine mounted regulator. The line, or high pressure, regulator lowers the gas pressure in the lines that feed the engine mounted gas regulators to a lower predetermined value, depending on the application. The engine regulator sets the gas pressure to the carburetor. From the engine mounted regulator the gas flows into the carburetor, where air is mixed with the gas.

The mixture then flows into the engine to be burned. Gas pressure to the engine regulator is typically 15-25 in H₂O for G4800 Series engines.

Low gas pressure will starve the engine of fuel and reduce engine output. Excessively high pressures could damage the regulator, allowing excessive fuel to the cylinders. This could lead to detonation and serious engine damage.

If at all possible, avoid feeding any gas operated equipment from the supply line between the line regulator and the engine regulator. The supply pressure to the engine could be disrupted.

A second line regulator may also be necessary if the initial line regulator is located far from the engine.

a. *Pressure drop between regulators.* The maximum pressure drop across a line regulator is generally 50-75 psi (3.5-5.2 bar). Consult the regulator manufacturer for specific information.

Carburetors. The carburetor on all gaseous fueled engines is designed to mix gas and air into a combustible mixture. Through a series of orifices, springs, and diaphragms, gaseous fuel and air are mixed to provide the proper fuel-to-air ratio for efficient engine operation. Carburetors are used to provide a constant fuel-to-air ratio under varying and constant loads.

The gas-to-air mixture must be established at start-up. Consult the engine manufacturer for instructions on gas carburetor settings.

Piping. Piping to the engine site is generally supplied by the utility. Installation piping will have to be fitted from the meter or main feed line to the engine. This piping should be absolutely clean and scale free. If possible, blow out the lines with clean, dry compressed air before mounting the regulator. Piping should be black iron or steel to avoid reacting with the sulfur in the fuel. *Never use galvanized metal or zinc alloy piping.*

The pipe size used should be the same size as the engine fuel inlet. All threaded pipes should be sealed to prevent leaks. A shut-off valve should be installed along the pipe span just before it enters a building.

WARNING

All gas installations in closed areas or buildings should have a positive shut-off valve to prevent gas leakage when the engine is shut down. Consult all applicable local, state, and federal building codes for each installation.

Natural gas piping should never run near furnaces, heating pipes, electric wiring, or exhaust manifolds. The high temperatures could cause an explosion.

Natural gas piping should always be insulated for added protection.

Always incorporate a flexible pipe connector in the piping system. Locate this flex connector as close to the engine regulator as possible.

Fuel treatment. Fuel filters and/or scrubbers are often recommended to remove dirt, rust, scale, water, and chemical contaminants from the fuel. If debris remains in the fuel, the regulator orifice and gas jets in the carburetor could clog up and reduce engine performance. In areas where the gas has a large sulfur content, specially treated scrubbers and cleaners should be used. Sulfur in the fuel would combine with the water formed in the combustion process to make sulfuric acid. The acid causes rapid corrosion of engine components.

Gas mixing. Some gas distribution systems add a propane-air mixture to the natural gas to compensate for low pressure conditions. This is called **gas mixing**.

Gas mixing lowers the octane level of the fuel. To determine the octane drop, take the percentage of propane added to the system and multiply it by the difference between the two octane levels. For example, if the normal natural gas supply is established at 115 octane and 25% of 95 octane HD-5 propane is added, the resulting octane number is decreased by 25% of the difference between 115 and 95, or 5. The resulting octane level would be 110. If the propane level is increased to 50%, the octane level would drop to 105. Depending on engine load, gas mixing can lead to damaging detonation. If detonation is experienced, the load must be reduced or the spark retarded, or both, when the engine is adjusted for natural gas. In areas where gas mixing is common, a second set of marks on the magneto will help the operator retard the spark quickly. The addition of propane-air mixture is proportioned so carburetor readjustment is not necessary.

HD-5 PROPANE FUEL SYSTEMS

Propane is a high Btu, low octane fuel that is generally sold and stored as a liquid. Propane is converted to a gaseous state at the engine, in a separate piece of equipment called a vaporizer. The liquified gas runs through the vaporizer and is warmed and converted to vapor. Propane fueled engines are most often used for non-prime power installation.

CAUTION

The other LPG fuel, butane, has too low an octane rating (approx. 80) to be a satisfactory fuel in modern engines.

The gas-to-air mixture must be established at start-up. Consult the engine manufacturer for instructions on gas carburetor settings.

This type of fuel system is very similar to the natural gas system; however, several additional components are needed.

FILTER. A small liquid stage filter should be used to protect the vaporizer, carburetor, and engine against fuel tank and line scale.

LPG VAPORIZER. This fuel is liquified by compressing it while it is in the gaseous state. The high pressures caused by compressing the gas convert it into a liquid. The liquid fuel is then stored. Before the fuel can be used by the engine, it has to be reconverted to a gas in the fuel vaporizer. Heated air or water runs through the vaporizer and warms the fuel to a gaseous state.

From there, the gas flows to the carburetor, where it is mixed with air. A vaporizer must be used on most LPG applications. Only very small engines can run off the gas vapor that forms in the fuel tank. See Appendix Section A.9 for propane vaporization data. Many local codes require an outside location for the fuel vaporizer. Contact your local distributor for the type of vaporizer that will be best for your installation.

Exterior propane fueled engine installations can usually be equipped with a combination vaporizer and pressure regulator (converter) mounted on the engine. These engine mounted converters use heated engine coolant to vaporize the liquid propane.

FUEL TANK. An approved LPG fuel tank must be used to store the fuel. Shut-off valves and pressure gauges are usually incorporated in the tank. Consult the tank manufacturer for more specific information.

Due to the volatile nature of the fuel, the tank should never be located inside any structure. (Most local codes require that the tank be installed outside a building.) Always plan the installation to keep the fuel tank away from open flames, sparks, or electrical connections.

Since propane gas is heavier than air, the tank enclosure should not contain any piping trenches or floor drains that would permit escaping gas to get under the building or into city storm drains or sewer systems.

HD-5 PROPANE FUEL SYSTEMS
(CONTINUED)

PIPING. As with piping for natural gas, never run an LPG line near heat sources, exhaust manifolds, or electric wires. This particular fuel will vaporize at 44°F or (-42°C). Any excess heat or loss of pressure could lead to rapid fuel vaporization within the system. Try to keep the pipe spans as short as possible. Piping can be insulated for added protection.

CARBURETORS. As with the natural gas engines, a propane carburetor is nothing more than a gas and air mixer. The springs, orifices, and diaphragms will determine the gas-to-air ratios. Carburetor adjustment is outline in the engine operation and service manuals.

FITS AND TOLERANCES

MODEL D-4800 & D-4800-T

CLEARANCES - CONTINUATION

<u>BACKLASH</u>	<u>MIN.</u>	<u>MAX.</u>
OIL PUMP DRIVE TO IDLER004	- .006
IDLER TO CRANKSHAFT004	- .006
CRANKSHAFT TO CAMSHAFT002	- .004
VALVE LASHHot and Cold		
Intake010	
Exhaust025	
VALVE STEM TO GUIDE		
Intake0021	- .0039
Exhaust0048	- .0056
VALVE SEAT RUNOUT002	T.I.R.
TAPPET CLEARANCE IN BLOCK0033	- .0048
VALVE ARRANGEMENT FRONT TO REAR		I,E,I,E,I,E,I,E,I,E,I,E.
MINIMUM OIL PRESURE	15 lb. @ 500 RPM (1700) F	
	35 lb. @ 1800 RPM (1700) F	
BELLOUSING FACE RUNOUT008	

TORQUE SPECIFICATIONS

MAIN BEARING CAP BOLTS	135 - 140	ft. lbs.
CONNECTING ROD BOLT	115 - 120	ft. lbs.
CAMSHAFT GEAR TO CAMSHAFT NUT	275 - 300	ft. lbs.
CRANKSHAFT PULLEY ASSEMBLY RETAINING BOLT	225 - 250	ft. lbs.
FLYWHEEL TO CRANKSHAFT BOLT	115 - 120	ft. lbs.
FLYWHEEL HOUSING TO CYLINDER BLOCK NUTS	40 - 45	ft. lbs.
OIL PUMP ATTACHING BOLTS	48 - 54	ft. lbs.
ROCKER ARM SHAFT BRACKET NUT	30 - 35	ft. lbs.
CYLINDER HEAD COVER ATTACHING	3 - 5	ft. lbs.
EXHAUST MANIFOLD NUTS	20 - 25	ft. lbs.
INTAKE MANIFOLD NUTS	20 - 25	ft. lbs.
VIBRATION DAMPER TO CRANKSHAFT PULLEY	30 - 35	ft. lbs.
OIL PUMP DRIVE GEAR NUT		50 ft. lbs

Service/Parts Bulletin

Number: 48

Date: 5/14/90

Model: D4800, D500,
G4800 & LD/LDT/
LDS-465 SERIES

Subject: CYLINDER HEAD GASKET, P/N 40-1098702 (NEW).

A new cylinder head gasket has been introduced to improve quality and performance of the D4800, G4800 and LDT-465 Series engines.

This bulletin is to inform you that the new torque on the cylinder head gasket is 157 ft. lbs. It is advised to step torque the head gasket on a cold engine to the prescribed torque per the sequence indicated below.

- Step 1 - Tighten to 110 ft. lbs.
- Step 2 - Tighten to 130 ft. lbs.
- Step 3 - Tighten to 157 ft. lbs.
- Step 4 - Re-torque to 157 ft. lbs.

NOTE "A": Head Gasket p/n 40-3891123 is no longer available.

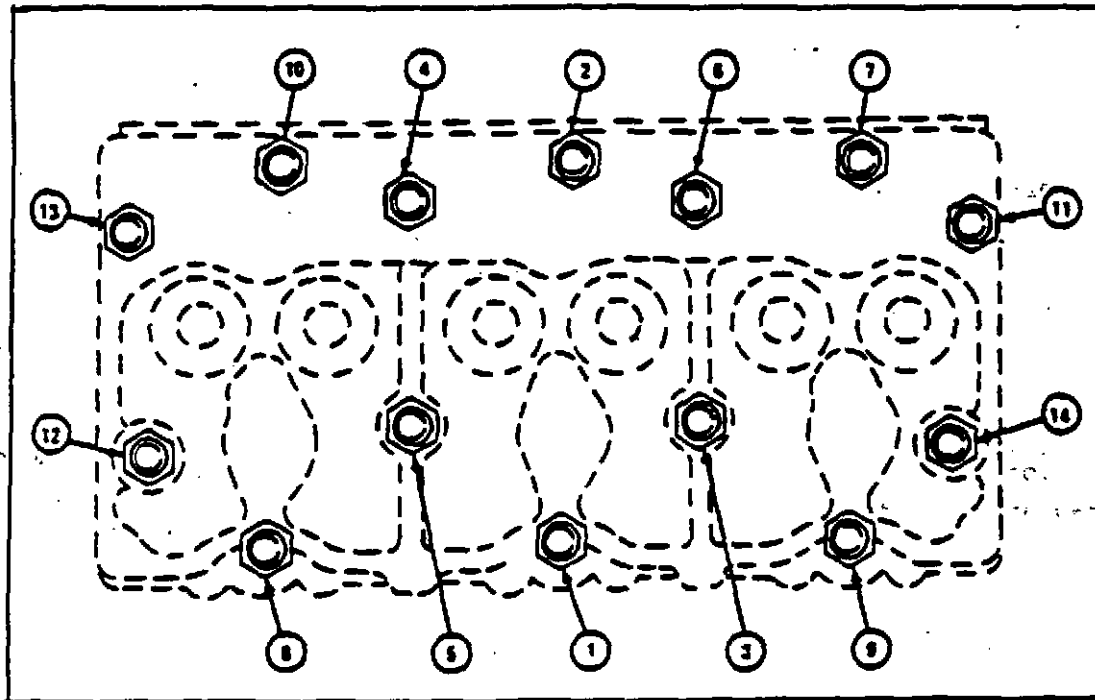

X941

NOTE "B": Do not use any sealants, aluminum paint etc., on this gasket. Do not retorque hot. If any seepage occurs, retorque cold only.

LUBRICATION (Continued)

Oil Change Period.....	1st @ 125 Hr. then every 500 Hrs.
Crankcase Capacity	
Without Filters.....	19 qt.
With Filters.....	22 qt.
Oil Filter Change Period.....	Every oil change

CAMSHAFT

Material.....	Carbon steel-forged
Standard End Play.....	0.006-0.015 in.
Thrust Plate Thickness.....	0.242-0.240 in.
Type of Drive.....	Gear
Cam Lift	
Intake.....	0.315 in.
Exhaust.....	0.330
Journal Diameters	
Front.....	2.4295-2.4285 in.
2nd.....	2.3670-2.3660 in.
3rd.....	2.3045-2.3035 in.
4th.....	1.9920-1.9910 in.

CAMSHAFT BUSHING AND BORE

Type.....	Steel backed, copper alloy
Bushing Bore	
Front.....	2.5620-2.5630 in.
Second.....	2.4995-2.5005 in.
Third.....	2.4370-2.4380 in.
Rear.....	2.1245-2.1255 in.
Bushing Inside Diameter (In Place)	
Front.....	2.4315-2.4325 in.
Maximum.....	2.4355 in.
Second.....	2.3690-2.3700 in.
Maximum.....	2.3730 in.
Third.....	2.3065-2.3075 in.
Maximum.....	2.3105 in.
Rear.....	1.9940-1.9550 in.
Maximum.....	1.9980 in.
Bushing Width	
Front.....	1.12 in.
Second.....	1.00 in.
Third.....	1.00 in.
Rear.....	1.26 in.
Running Clearance	
Standard.....	0.002-0.004 in.
Maximum.....	0.006 in.

CONNECTING RODS

Material.....	SAE 1045H steel forging
Rod Misalignment.....	Allowable twist--0.001 per inch of bearing length
Length from Center of Small End to Center of Large...	8.750 in.
Connecting Rod "Side" Clearance	
Standard.....	0.007-0.013 in.
Diameter of Piston Pin Bushing Bore.....	1.749-1.750 in.
Diameter of Rod Bearing Bore.....	3.251-3.252 in.
Maximum Difference Between Lightest and Heaviest Rod in Set.....	1.0 oz.
Number of Connecting Rod Cap Bolts.....	2
Bolt Thread Size.....	9/16-18 UNF-3A

CONNECTING ROD BEARINGS

Type.....	Replaceable shell, precision
Material.....	Steel backed, copperlead base, tin plate
Running Clearance	
Standard.....	0.0014-0.0044 in.
Maximum.....	0.0065 in.
Bearing Width.....	1.45 in.
Undersize.....	0.010 and 0.020 in.

CRANKSHAFT

Material.....	Steel forging
Type.....	Dynamically balanced
End Play Controlled by.....	Center main bearing
End Play	
Standard.....	0.010-0.014 in.
Maximum.....	0.018 in.
Number of Main Bearings.....	7
Main Bearing Journal Diameter.....	3.6210-3.6220 in.
Maximum Journal Out-of-Round or Taper.....	0.0005 in.
Main Bearing Journal Length	
1st, 2nd, 3rd, 5th, 6th, 7th.....	1.608-1.618 in.
4th.....	2.137-2.139 in.
Connecting Rod Journal Diameter.....	2.9970-2.9980 in.
Maximum Connecting Rod Journal Length.....	1.778-1.782 in.
Main Bearing Cap Bolt Thread Size.....	9/16-12 UNC
Maximum Flywheel Mounting Flange Runout.....	0.002 in.
Maximum Allowable Shaft Misalignment.....	0.003 in. @No. 4 main brg. journal 0.002 in. remaining main journals

VALVES (Continued)

Valve Running Clearance in Guides

135 H.P.

Intake	
Standard.....	0.0015 - 0.0039 in.
Maximum.....	0.0045 in.
Exhaust	
Standard.....	0.0021 - .0045 in.
Maximum.....	0.0057 in.
Valve Face Angle	
Intake & Exhaust.....	30°
Valve Protr. Above Deck.....	0.034 - 0.012
Valve Head Diameter	
Intake.....	2.035 - 2.025 in.
Exhaust.....	1.755 - 1.745
Valve Timing	
Valve Clearance for Checking Valve Timing	
Intake.....	0.010 in.
Exhaust.....	0.025 in.
Intake Opens.....	-16° BTDC
Intake Closes.....	20° ABDC
Exhaust Opens.....	34° BBDC
Exhaust Closes.....	-18 ATDC
Valve Lift	
Intake.....	0.485
Exhaust.....	0.472 - .508 in.
Valve Port Diameter.....	Refer to Cyl.head Specifications
Maximum Valve Face Runout.....	0.002 in.
Maximum Valve Seat Runout.....	0.002 in.
Valve Margin - Minimum.....	1/64 in.
Valve Clearance (Cold)	
Intake.....	0.010 in.
Exhaust.....	0.025 in.

VALVE GUIDES

Type.....	Straight	
Material.....	Cast iron	
Valve Guide Bore		
Intake and Exhaust.....	0.4388-0.4394 in.	
Maximum.....	0.4406 in.	
O.D.....	0.6885-0.6880 in.	
Length.....	3.46 in.	
Valve Guide Height above Counterbore of Cylinder Head.....		1.260 in.

VALVE SPRINGS

Material.....Spring Steel
Free Length
 Intake.....2.500
 Exhaust.....2.500
Compressed Length
 Valve Closed
 Intake.....2.12 in.@ 102.2+ 3 lb.
 Exhaust.....2.12 in.@ 102.2+ 3 lb.
 Valve Open
 Intake.....1.67 in.@ 247.2+ 7 lb.
 Exhaust.....1.67 in.@ 247.2+ 7 lb.

VALVE LIFTERS

Type.....Straight
Diameter
 Standard.....1.2480-1.2475 in.
 Minimum.....1.2425 in.
Lifter Guide Bore
 Standard.....1.2513-1.2523 in.
 Maximum.....1.2543 in.
Running Clearance.....0.0033-0.0048 in.

FLYWHEEL WITH RING GEAR

Maximum Runout.....0.008 in.
Diameter.....17.440 in.
Ring Gear Teeth (Number).....138

IDLER GEAR

Shaft Diameter.....0.7875-0.7872 in.

OIL PUMP

Type.....Gear
Relief Valve Setting.....95-105 psi
Relief Valve Spring
 Free Length.....2.000 in.
 Compressed Length.....1.81 in.@ 52+ 5.0 lb.
Relief Valve Plunger Diameter.....0.8125-0.8120 in.
Drive & Driven Gear Clearance
 Standard.....0.0020-0.0055 in.
 Maximum.....0.0080 in.

OIL PUMP (Continued)

Drive Shaft Running Clearance in Housing
Standard.....0.001-0.003 in.
Maximum.....0.005 in.
Driven Shaft Running Clearance in Bushings
Standard.....0.0010-0.0025 in.
Maximum.....0.0045 in.

PUSH RODS

Length.....14.744 ± 0.015 in.
Maximum Runout.....0.020 in.

ROCKER ARMS

Rocker Arm Shaft Spring
Free Length.....3.500 in.
Compressed Length.....2 in. @ 8.8 ± 1 lb.
Rocker Arm Running Clearance
Standard.....0.002-0.004 in.
Maximum.....0.0050 in.

ROCKER ARM SHAFT

Shaft Diameter
Standard.....1.0005-0.9998 in.
Minimum.....0.9978 in.

PISTONS

Material.....Alumimum alloy
Pistons Removed from.....Top
Length.....5.041
Maximum Skirt Dimension.....4.5593-4.5592 in.
Top and 2nd Piston Ring Groove.....4.133-4.123 in.
Oil Ring Groove Width.....0.1575-0.1565
Piston Pin Bore Diameter
Standard.....1.6251-1.6253 in.
Maximum.....1.6263 in.
New Piston Fit in New Sleeve.....0.0037-0.0053 in.

PISTON PINS

Type.....Full Floating
Installation.....Fit pin at room temperature with thumb pressure
Pin Held in Position by.....Retaining rings
Outside Diameter
Standard.....1.6249-1.6247 in.
Minimum.....1.6243 in.
Running Clearance in Pistons
Standard.....0.0002-0.0006 in.
Maximum.....0.002 in.
Running Clearance in Rod
Standard.....0.0016-0.0020 in.
Maximum.....0.0030 in.
Rockwell "C" Hardness.....58-62

PISTON PIN BUSHING

Type.....Slotted and split
Material.....Steel backed bronze
Inside Diameter
Reamed in Place.....1.6265-1.6267 in.
Length.....1.60

PISTON RINGS

Material.....Top: Nodular Iron-Moly Filled
2nd: Nodular iron-chrome faced
Compression Rings per Piston.....2
Oil Ring Side Clearance.....0.002-0.004 in.
Compression Ring End Gap
Top.....0.014-0.024 in.
2nd.....0.011-0.021 in.
Maximum.....0.040 in.
Oil Ring End Gap
Standard.....0.015-0.025 in.
Maximum.....0.050 in.

SLEEVES

Type.....	Dry
Material.....	Cast Iron
Brinnell Hardness.....	229-269
Bore	
Standard.....	4.5630-4.5645 in.
Maximum (Measured One Inch from Flange).....	4.5665 in.
Out-of-Round	
Maximum (Not Installed).....	0.012 in.
Taper	
Maximum.....	0.0005 in.
Overall Length.....	9.670 in.
Projection above Crankcase (for Gasket Crush).....	0.0005-0.0050 in.
Crankcase Sleeve Bore.....	4.7511-4.7520 in.
Crankcase Sleeve Counterbore.....	5.010-5.015 in.
Sleeve Counterbore Depth in Crankcase.....	0.184-0.186 in.
Sleeve Flange Thickness.....	0.1880-0.1865 in.
Sleeve Outer Diameter	
Upper Flange.....	5.005-5.000 in.
Body.....	4.7505-4.7495 in.
Sleeve Upper Flange Clearance in Crankcase.....	0.005-0.015 in.

TIMING GEARS

Type.....	Helical
Material.....	Alloy Steel
Back Lash	
Idle Gear to Crankshaft Gear.....	0.004-0.006 in.
Maximum for Wear.....	0.007 in.
Camshaft Gear to Crankshaft Gear.....	0.002-0.004 in.
Maximum for Wear.....	0.005 in.

TORQUE WRENCH VALUES IN FOOT-POUNDS (OILED)

Cylinder Head Stud Nuts.....	See X-941
Cylinder Head Cover Bolts and Nuts.....	3-5
Main Bearing Cap Screws.....	135-140
Connecting Rod Cap Screws.....	115-120
Water Manifold Cap Screws.....	17-19
Manifold Nuts.....	20-25
Rocker Arm Shaft Bracket Cap Screws.....	30-35
Flywheel Cap Screws.....	115-120
Flywheel Housing to Cylinder Block Nuts.....	40-45
Vibration Damper Cap Screws.....	30-35
Pulley Cap Screw.....	225-250
Camshaft Gear Attaching Nut.....	275-300
Oil Pump Attaching Bolts.....	48-54
Oil Pump Drive Gear Nut.....	50

GENERAL DESCRIPTION AND FEATURES OF DESIGN

CYLINDER BLOCK AND CRANKCASE

The cylinder block and crankcase are cast in one piece. In order to permit more efficient cooling, the cylinders are water jacketed the full length of the bore. This construction results in a very rigid unit, which provides a sturdy support for the crankshaft.

MAIN BEARINGS

The six cylinder engine has seven main bearings. This places a main bearing on each side of each connecting rod bearing, see Illustration No. 1. This construction helps to eliminate vibration at high speeds. The bearing caps are held in place by two alloy steel capscrews.

The crankshaft end thrust is controlled by the center main bearing. This shell has suitable flanges on both sides of the bearing, which form a thrust bearing.

Precision or insert type bearings are used. In this construction there is a removable shell in each cap, as well as for the upper part. The upper shell is not interchangeable with the lower shell except for the thrust bearing. These bearing shells are completely finished before being put on place and no line reaming or scraping is required. This allows replacement of the bearings to be easily accomplished. Each bearing shell has a small ear or projection which fits into a recess in the cylinder block or cap, which allows the ear or projection to rest against the adjoining case or cap to prevent the shell from rocking or rotating. These shells are trimetal bearings, steel backed. This permits the use of a hardened crankshaft.

CYLINDER HEAD

The engine has two cylinder heads made from heat treated alloy iron, valve seats and valve guides are replaceable. The head is held to the cylinder block by studs, and nuts; and, in order to insure against leaks, the head must be carefully drawn down by means of the stud nuts, which should be progressively tightened, working from the center of the head toward the ends. See Illustration No. 20 for method and sequence for torquing cylinder head.

CONNECTING RODS AND PISTONS

Like the main bearings, the connecting rods have the precision or insert type of bearing construction. No shims are used, therefore, bearing adjustment is accomplished by installation of new bearing inserts.

The piston pin is of very large diameter and is of the full floating type. This means that pin can rotate in either the piston bosses or in the bushing at the top end of the connecting rod, but the fit in the piston is tighter than the fit in the connecting rod bushing. Consequently, the pin can not rotate in the rod any faster than the piston allows.

The piston pin is prevented from moving endwise and making contact with the cylinder wall by means of snap rings, which are located in grooves machined in the bosses of the piston.

CAMSHAFT

The camshaft is supported on removable bearings in the crankcase. The camshaft end thrust is controlled by a thrust plate between the front camshaft bearing and the camshaft gear. This plate is held to the cylinder block by two capscrews.

VALVES

The valves are installed in the cylinder head. The intake valve head is larger in diameter than the exhaust valve head in order to increase the efficiency and insure more power. Both intake and exhaust valves are forged from special alloy steel. The valve tappets are hollow to allow the push rod to properly seat.

OIL SYSTEM

The lubricating system is the pressure type, having gear type oil pump with the suction end in the oil pan oil sump and, there-

fore, needs no priming. The oil pump is gear driven through a suitable gear arrangement at the front of the engine. The oil Tubes and oil pan may be rotated depending on the application.

The oil pump forces the oil under pressure through a full-flow oil filter and oil cooler to the main oil header in the cylinder block. This oil header is a drilled passage extending the length of the cylinder block on the side opposite the camshaft and is closed at both ends with suitable plugs.

The oil pressure is controlled by a pressure control mechanism assembled on right side of cylinder block, see Illustration No. 35, which connects directly with the oil header. Also, there is a safety pressure relief valve assembled to the oil pump which prevents excessive pressure build-up. See item "A" Illustration No. 1.

From the main header the oil is distributed, under controlled pressure, through drilled passages to all main bearings, camshaft bearings, and rocker arms. From the main bearings, oil is delivered under pressure, through drilled passages in the crankshaft, to all connecting rod bearings. See Illustration.

The cam lobes, valve tappets and so forth are lubricated by means of oil drain-back and the mist of oil thrown off around the various pressure-lubricated bearings. The pistons are cooled by a spray nozzle located on block. See Illustration No.

External openings are provided for connection of an oil pressure gauge or other accessories requiring pressure lubrication.

LUBRICATION SYSTEM

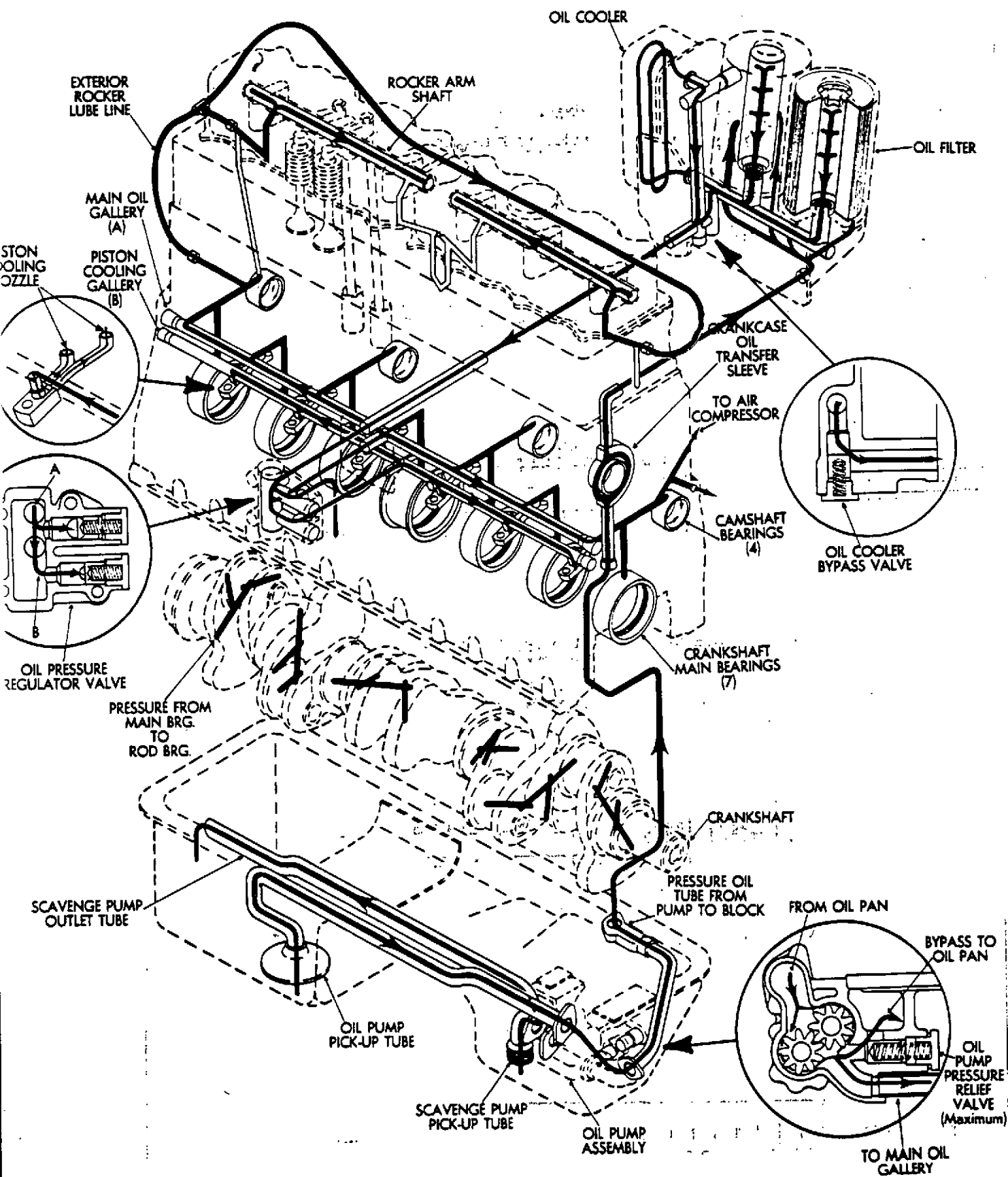

WIRING DIAGRAM

Due to many types of electrical equipment and the variety of requirements encountered in different installations, it is impossible to illustrate a typical wiring diagram.

However, the installation of wiring circuits may be more readily understood if the complete system is divided as follows:

1. THE STARTER SYSTEM

This circuit consists of the battery (electrical energy storage unit), the starting motor and the necessary wiring to connect the battery to the starter switch and from the starter switch to the starter.

In most cases, the ground or return flow of current is carried through the frame work of the unit to a point near the battery from where a short cable is connected to the battery to complete the circuit.

When a magnetic type starter switch is used, it is necessary to connect it to a control switch, which may be either a key switch or a simple push button switch. The key switch has one side connected to the battery side of the ammeter and the other side to the magnetic switch with suitable wires. The magnetic switch may have an external ground post which must be grounded to the unit framework. The push button switch has one side connected to the battery side of the ammeter and the opposite side connected to the magnetic starter switch as outlined above.

2. BATTERY CHARGING SYSTEM

The battery charging system consists of an alternator, which creates the electrical current, a regulator to control the current, and an ammeter to indicate the amount of current being crated or used.

3. ACCESSORY SYSTEM

The accessory system consists of lights, horns, heaters, etc. The current to operate these accessories is usually taken from the ammeter to a suitable switch, which allows the accessories to be operated or turned off as necessary.

TROUBLE SHOOTING

NOTE: Numbers in each column indicate sequence in which problem should be checked CAUSE	PROBLEM												
	Engine Will Not Start	Engine Stops	Hard Starting	Erratic Engine Performance	Blue Exhaust Smoke	White Exhaust Smoke	Low Power	Engine Over-Heating	Engine Over-Cooling	Low Oil Pressure	Bearing Failures		
Air Cleaner Dirty Air Inlet Restricted	11		3	2			1						
Exhaust System Restricted		6		13			13	10					
Battery Weak or Discharged Battery Cables Worn or Loose Connection	5 4		1 5										
Low Cylinder Compression Foreign Matter on Pistons Worn or Scored Pistons, Rings, Etc.			10 15	11 17 18	5 7	11 16 17		7 8				11	
Valves Leaking or Sticking Worn Valve Guides Valves Incorrectly Adjusted	14 13		14 13	16 15	8	15 14		6 5					
Luboil Level Top Low Luboil Level Too High Luboil Contaminated Wrong Type of Luboil			18		1 3			1 4 3	1 3	1 2			
Oil Pump Inlet Screen Plugged Pressure Regulator Not Functioning Rocker Arm Shaft Upside Down Oil Header Plug Missing or Loose Bearing Failed, Main, Rod, Cam					6			6 7 5 10	8 9 12				
Excessive Angle Operation Excessive Thrust Pressure on Shafts	16	12	17		2			2 9	5 10				
Fuel Supply Empty Fuel Valve Closed Fuel Regulator Vent Plugged	2 3	1 2 3		6									
Fuel Contamination Fuel Incorrect For Conditions Fuel Filter Dirty or Plugged	6 7 8		5 8 9	7 6 7	4	4 5		2					
Ignition Switch in OFF Position Defective Coil or S Plugs Ignition Timing Incorrect	1 9 10		7 9 8	4 4		8 7				3			
Throttle Linkage Adj. Incorrect or Sticking Carburetor Malfunction Air Leak in Intake System				12		9							
Fan Belt Loose or Slipping Radiator Fins or Tubes Dirty or Restricted Water System Filled Incorrectly Low Coolant Level Coolant in Cylinders Inoperative Thermostat Thermostat Missing Internal Coolant Leak Wrong Defective Radiator Cap	15		15 19			3 1 2		3 4 6 1 5 3	1 2				4
Engine Overload Engine Overspeeded						8 9			4			6 7	

ALTRONIC V IGNITION SYSTEM INSTALLATION INSTRUCTIONS

WARNING: An improperly installed or operating ignition system may lead to improper engine operation which consequently could pose the threat of personal injury to operators or other nearby personnel.

The following parts are required for each installation:

1. Altronic V Unit
2. Wiring Harness
3. Ignition coils - 40-2505254 1-Per Spark Plug

ENGINE

Set engine so that No. 1 cylinder is at the ignition firing point. 20° BTDC

Remove oil fill cap and verify that #2 Exh. rocker is in the down position, if not, rotate engine 180°.

ROTATION

Determine the rotation of the Altronic V unit (looking at the drive end of the Altronic unit) for the engine being equipped. (CW)

ALTRONIC V UNIT

Locate the timing mark on the housing for the proper rotation. Rotate the drive coupling until the red mark on the shaft lines up with the proper mark on the housing. Figure 1 shows the timing mark indication and drive coupling alignment for the standard SAE CCW and CW configurations.

Mount unit to engine keeping the above two red lines together as close as possible. If the two lines cannot be made to meet by rotating the entire unit, remove the four screws which fasten the back cover assembly to the unit. The entire back cover assembly should then be pulled away from the unit keeping the internal plug connected. Rotate the driven gear until the two marks described above line up. With the plastic cover removed, use one finger on the timing decal to maintain the distributor shaft in the correct position (proper red marks line up) and reinstall the cover to the unit, engaging the gears. Securely tighten the four fastening screws. Final timing should be checked using a timing light with the engine at idle speed. Rotate unit CW to retard, CCW to advance.

IGNITION COILS AND SECONDARY WIRING

Use only one of the Altronic coils listed above; standard low-tension magneto coils will not work properly with this system. Mount the coils as close as possible to the engine spark plugs.

The use of a clear, silicone grease (such as Dow Corning DC-200) is recommended for all high tension connections and boots. This material helps seal out moisture and prevent corrosion from atmospheric causes as well.

PRIMARY WIRING

The firing order of the Altronic V units is as follows;

CYL.	UNIT	CW ROTATION	WIRING DIAGRAM
6*	6A34	A-F-E-D-C-B	6

* Unit fires each cylinder individually on compression stroke only.

Starting with lead "A" to the coil of #1 cylinder, the harness leads are connected in accordance with the engine's firing order to the positive (+) terminals of the coils (see Wiring Diagrams). On exhaust stroke firing units (**), the coils for the cylinders with matching harness letters are connected in series as shown in the Wiring Diagrams. The switch or shutdown panel wire is "E" for units with 5-pin connector and "G" for units the 7-pin connector. A common ground lead connecting the negative (-) terminals of the coils must be run as shown in the diagrams.

All connections should be made using ring type terminals specified for 16 gauge wire and #10 stud size. Terminals should either be soldered to the wire or attached with an appropriate staking tool. All primary wiring should be protected from physical damage, vibration and temperatures in excess of 220°F. Any unused leads in the wiring harness should be taped and left open-circuited (not connected).

Make sure shorting plug is attached at back of mag. when not using external timing.

CW ROTATION

UNIT 6A34 - 6 CYLINDER

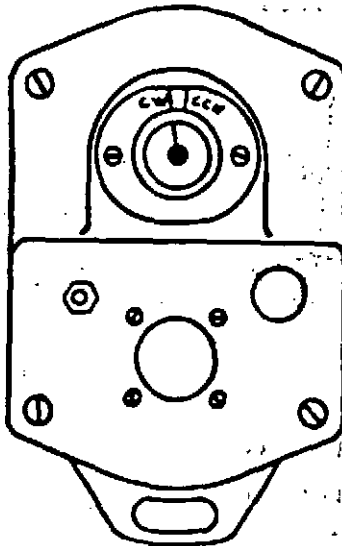

IGN. ROTATION		ENGINE FIRING ORDER
CCW	CW	
A	A	1
B	F	5
C	E	3
D	D	6
E	C	2
F	B	4

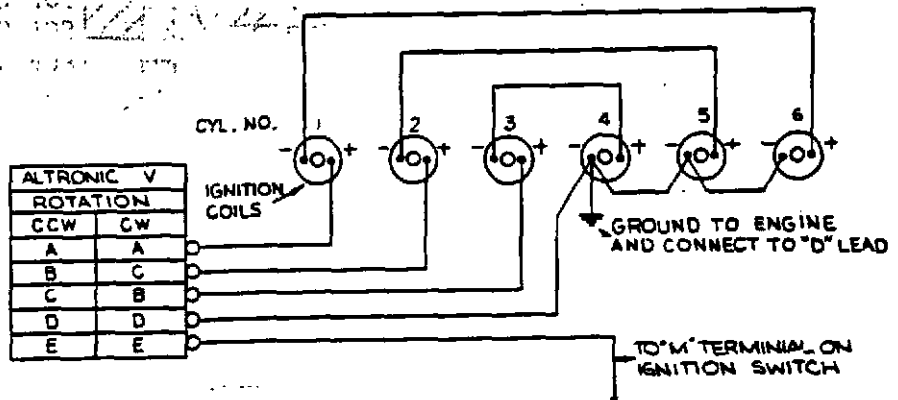

SERVICE MANUAL

ALTRONIC V IGNITION SYSTEM
4400 SERIES S/N 4400 & UP

IMPORTANT SAFETY NOTICE

The procedures called for herein require the use of special tools and heavy duty machine equipment. Personnel performing such repairs should be trained in the use of such equipment and be knowledgeable of their potential safety hazards so as to be able to safely perform the recommended procedures.

Proper repair and maintenance is essential to the safe and reliable operation of this equipment and the engine to which it is applied. Failure to follow the recommended practices could lead to potentially hazardous conditions. An improperly installed or operating ignition system may lead to improper engine operation which consequently could pose the threat of personal injury to operators or other nearby personnel.

1.0 ALTRONIC V IGNITION SYSTEM - DESCRIPTION

Altronic V is an alternator powered, electronic ignition system. All electronic parts are mounted to the back cover which disconnects as a module from the alternator section.

The alternator (A) provides the power to charge energy storage capacitor (B). A separate pick-up coil (C) and SCR (D) are used for each of the system's outputs which correspond usually to each engine cylinder. A rotating timer arm (E) driven through speed reducing gears passes over the pick-up coils to trigger on the SCR switches in sequence. This releases the capacitor's stored energy to the ignition coils which step up the voltage to fire the spark plugs.

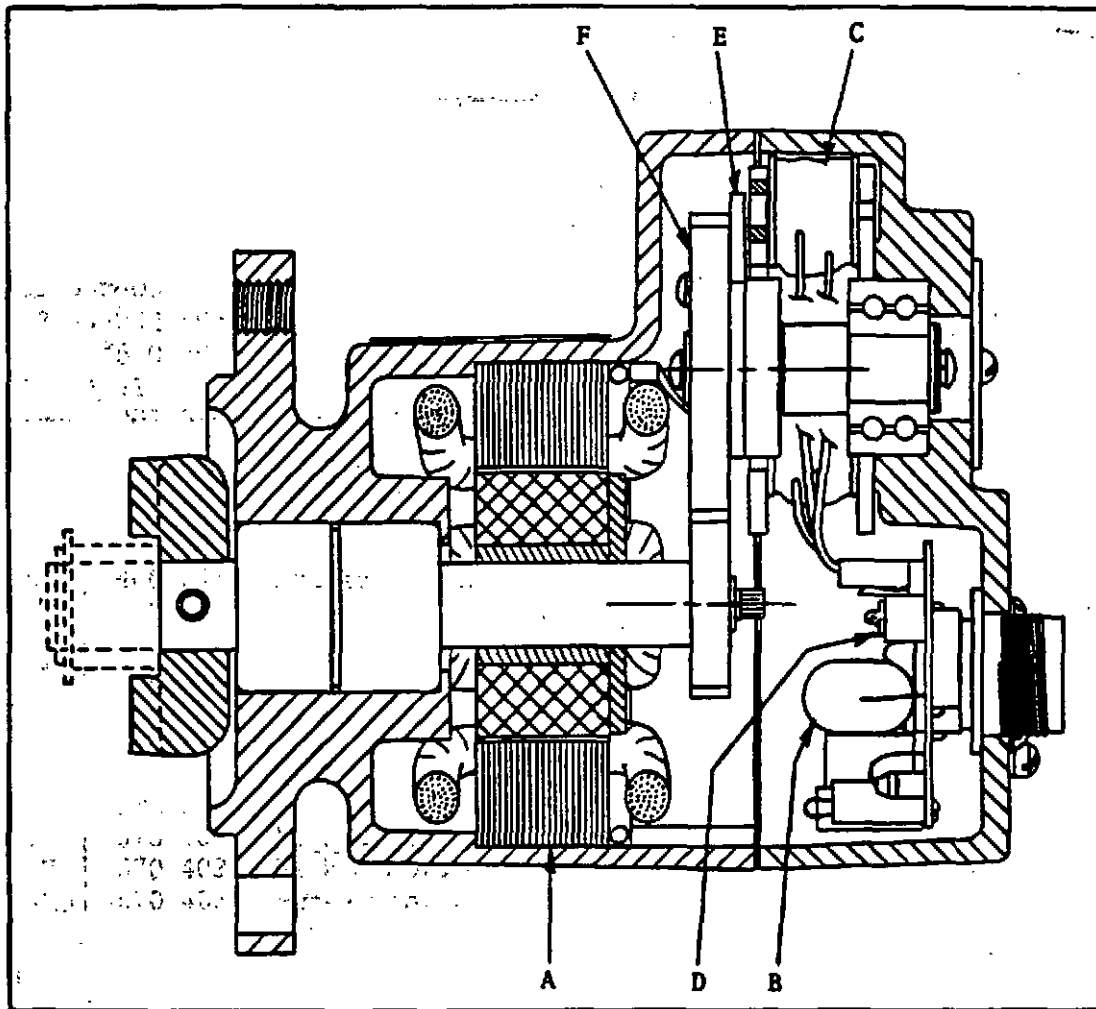

CROSS SECTIONAL VIEW - ALTRONIC V UNIT

A - Alternator
B - Energy storage capacitor
C - Pick-up coil

D - SCR electronic switch
E - Timer arm
F - Distribution gears

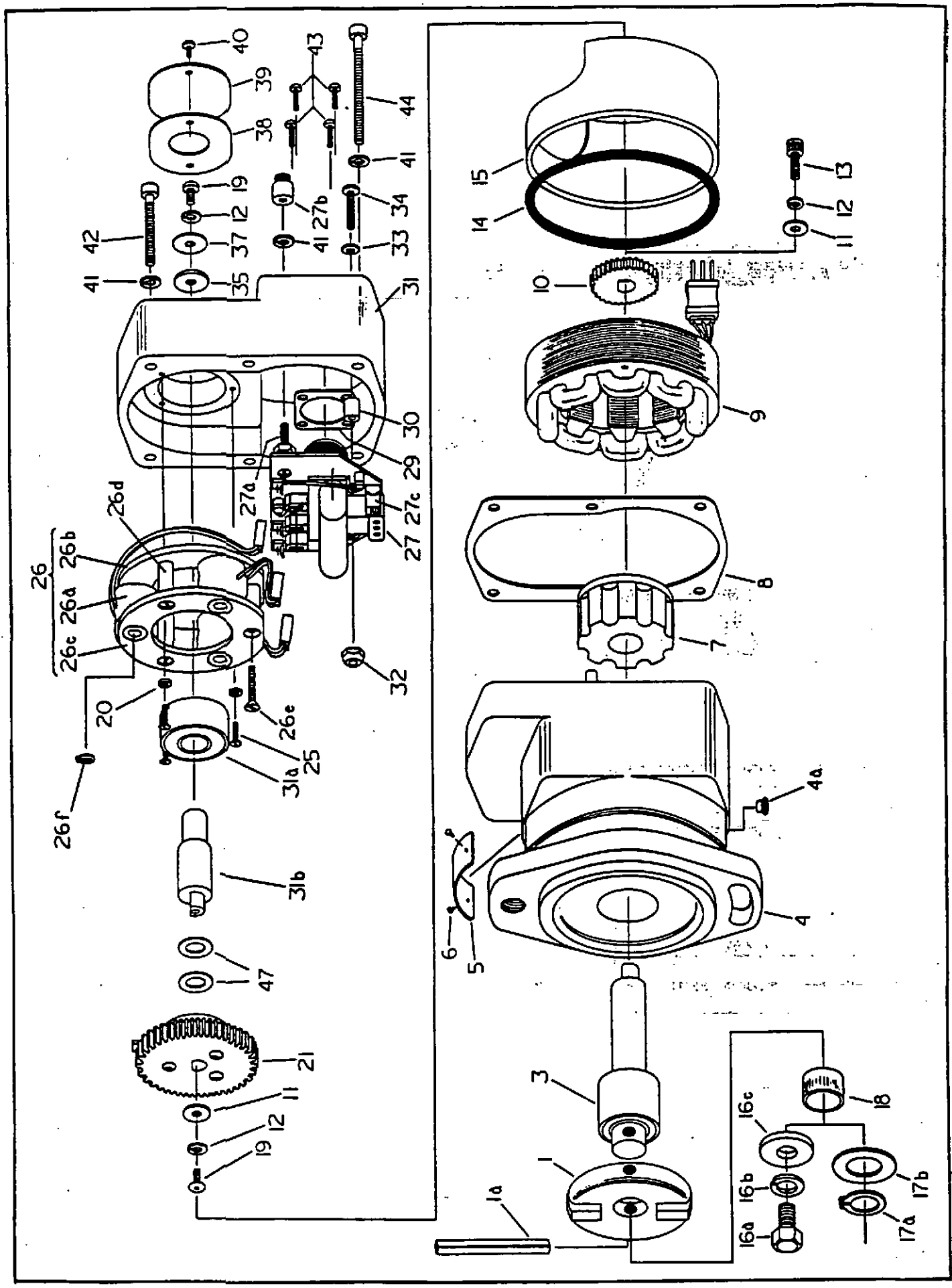

2.0 PARTS IDENTIFICATION AND SPECIFICATION

2.1 PARTS LIST - ALTRONIC V - Reference the exploded view on page 4.

REF.	PART NO.	DESCRIPTION	REF.	PART NO.	DESCRIPTION
1	510 454-U	Coupling	26b	570 008	Plate-core ass'y. 2A
1a	902 478	Spring Pin		570 009	Plate-core ass'y. 3A
3	410 063	Bearing-shaft(-A,-AM,-D)		570 015	Plate-core ass'y. 1A
	510 654	Bearing-shaft(-AW,-GVW)		570 025	Plate-core ass'y. 4A
4	560 004-1	Housing(-A,-AM,-AW)		570 026	Plate-core ass'y. 5A
	560 004-2	Housing(-GV,-GVW)		570 027	Plate-core ass'y. 6A
	560 004-3	Housing(-D)	26c	570 010	Plate-bushing ass'y. 3A
4a	510 541	Ventilator		570 011	Plate-bushing ass'y. 2A
5	502 134	Nameplate - 2.0" X 1.9"		570 012	Plate-bushing ass'y. 1A
	502 168	Nameplate - 3/5" X 1.1"		570 020	Plate-bushing ass'y. 4A
6	902 520	Drive pin		570 021	Plate-bushing ass'y. 5A
7	160 001	Magnet-rotor		570 022	Plate-bushing ass'y. 6A
8	410-039	Gasket	26d	510 627	Spacer - 1A, 2A, 3A
9	571 003	Stator		510 651	Spacer - 4A, 5A, 6A
10	310 518	Drive gear 1.5:1	26e	902 574	Screw 6-32
	510 357	Drive gear 2:1	26f	610 117	Snap ring
	510 359	Drive gear 3:1	27	See pg 6	Circuit board ass'y.
	510 625	Drive gear 1:1	27a	301 208-2	Zener diode - 10M120Z5
11	901 326	Washer		301 233-3	Zener diode - 10M150Z5
12	900 944	Lockwasher #8	27b	504 161	Nut 10-32 - zener diode
13	902 465	Screw 8-32	27c	583 007	Plug assembly
14	510 462	O-ring	29	501 335	Gasket - 5-pin connector
15	410 038	Spacer		501 368	Gasket - 7-pin connector
16a	902 585	Screw 5/16"-18	30	510 597	Spacer
16b	901 010	Lockwasher 5/16"	31	570 005	Rear cover - 5-pin conn
16c	902 586	Washer		570 028	Rear cover - 7-pin conn
17a	902 487	Snap ring		570 029-1	Rear cover-5-pin w/timing
17b	902 503	Washer		570 029-2	Rear cover-7-pin w/timing
18	410 045	Spacer	31a	410 058	Bearing
19	902 541	Screw 8-32	31b	510 660	Shaft - driven
20	900 996	Lockwasher #4	32	902 459	Nut 6-32
21	570 017-1	Driven gear ass'y. 1:1	33	902 602	Washer
	570 017-2	Driven gear ass'y. 2:1	34	902 565	Screw 6-32
	570 017-3	Driven gear ass'y. 3:1	35	902 591	Washer
	570 017-6	Driven gear ass'y. 1.5:1	37	302 106	Timing label - shaft
25	902 564	Screw 4-40	38	502 142	Timing label - cover
26	570 401	Pick-up plate ass'y. 1A	39	310 365	Cover plate
	570 402	Pick-up plate ass'y. 2A	40	902 058	Screw 6-32
	570 403	Pick-up plate ass'y. 3A	41	901 004	Lockwasher #10
	570 404	Pick-up plate ass'y. 4A	42	902 567	Screw 10-24 X 1.25"
	570 405	Pick-up plate ass'y. 5A		902 587	Screw 10-24 X 2.0"
	570 406	Pick-up plate ass'y. 6A	43	902 064	Screw 6-32
26a	See pg.11	Pick-up coil ass'y.	44	902 483	Screw 10-24
			47	902 579	Washer - shim
			*	562 001	Connector ass'y.
			*	501 369	Gasket
			*	900 996	Lockwasher #4
			*	902 525	Screw 4-40

* Parts for units with electronic timing

option (not illustrated).

NOTE: Reference numbers with a letter suffix are part of the assembly of the same number without the suffix. Example

(1a) is part of (1).

3.0 PERFORMANCE SPECIFICATIONS

- A. Install unit on a test stand equipped with a suitable number of 501 061 coils and spark gaps. Test stand wiring should conform to that shown in the Installation Instructions form AV II for 6-cylinder engines.

3.1 VOLTAGE TEST

- A. Remove the harness from the unit connector. At 500 RPM the positive voltage at the pin shown with respect to ground should be:

CIRCUIT BOARD	CONNECTOR PIN	VOLTAGE
572 602, 572 612	"E"	114-126 VDC
572 602H, 572 612H	"E"	143-157 VDC
572 603, 572 613	"E"	143-157 VDC
572 604, 572 614	"G"	143-157 VDC
572 606, 572 616	"G"	143-157 VDC

3.2 OPERATING TEST

- A. At 90-120 RPM, a 7mm gap should fire consistently
 B. At the TEST RPM, a 15 mm gap should fire consistently.

3.3 TIMING SPECIFICATION

- A. Timing should be as specified in the table below as measured on a standard ignition test stand with the degree wheel indicator rotating at the unit coupling speed.
 B. If timing is out of specification, change the pick-up coil (26a) in question.

UNIT MODEL	TEST RPM	FIRING SEQUENCE IN DEGREES						TOLERANCE ±
		A	B	C	D	E	F	
1A18	1,300	0*						-
1A28	1,300	0**						-
2A14	2,000	0 - 180						2
2A18H	700	0 - 180						2
2A25	2,400	0 - 0						2
2A28	1,300	0 - 0						2
2A64	3,000	0 - 90 180 - 270						3
3A14	2,000	0 - 120 - 240						2
3A25	2,000	0 - 240 - 120						2
3A35	3,000	0 - 0 - 0						3
3A64	3,000	0 - 0 - 0 180 - 180 - 180						3
4A24	2,000	0 - 180 - 0 - 180						2
4A34	3,000	0 - 270 - 180 - 90						3
5A24	2,000	0 - 144 - 288 - 72 - 216						2
6A24	2,000	0 - 120 - 240 - 0 - 120 - 240						2
6A34	3,000	0 - 180 - 0 - 180 - 0 - 180						3

* 15-17 degree retard at low speed.

** 30-34 degree retard at low speed.

4.0 TROUBLESHOOTING

4.1 CIRCUIT DIAGRAM

- A. The diagram below shows the Altronic V circuit for one output. Each component in the Timing-Distribution section (to the right of the dotted line) is present in a quantity equal to the number of system outputs; each output requires a pick-up coil assembly, capacitor C3 and Power SCR2.
- B. The operation is as follows: The AC voltage generated by the alternator is converted to DC by rectifiers and stored in the energy storage capacitor (C1). The DC voltage level is controlled by zener diode Z. Capacitor C2 is charged through resistor R1 to provide the energy to trigger the power SCR (SCR2). This occurs when the rotating distributor timer arm passes a pick-up coil (P) triggering on SCR1 and connecting capacitor C2 through resistor R3 to the gate of SCR2. SCR2 then turns on discharging capacitor C1 into the primary of the ignition coil which steps up the voltage to fire the spark plug.
- C. Capacitor C3 acts as a filter to prevent crossfiring between cylinders.

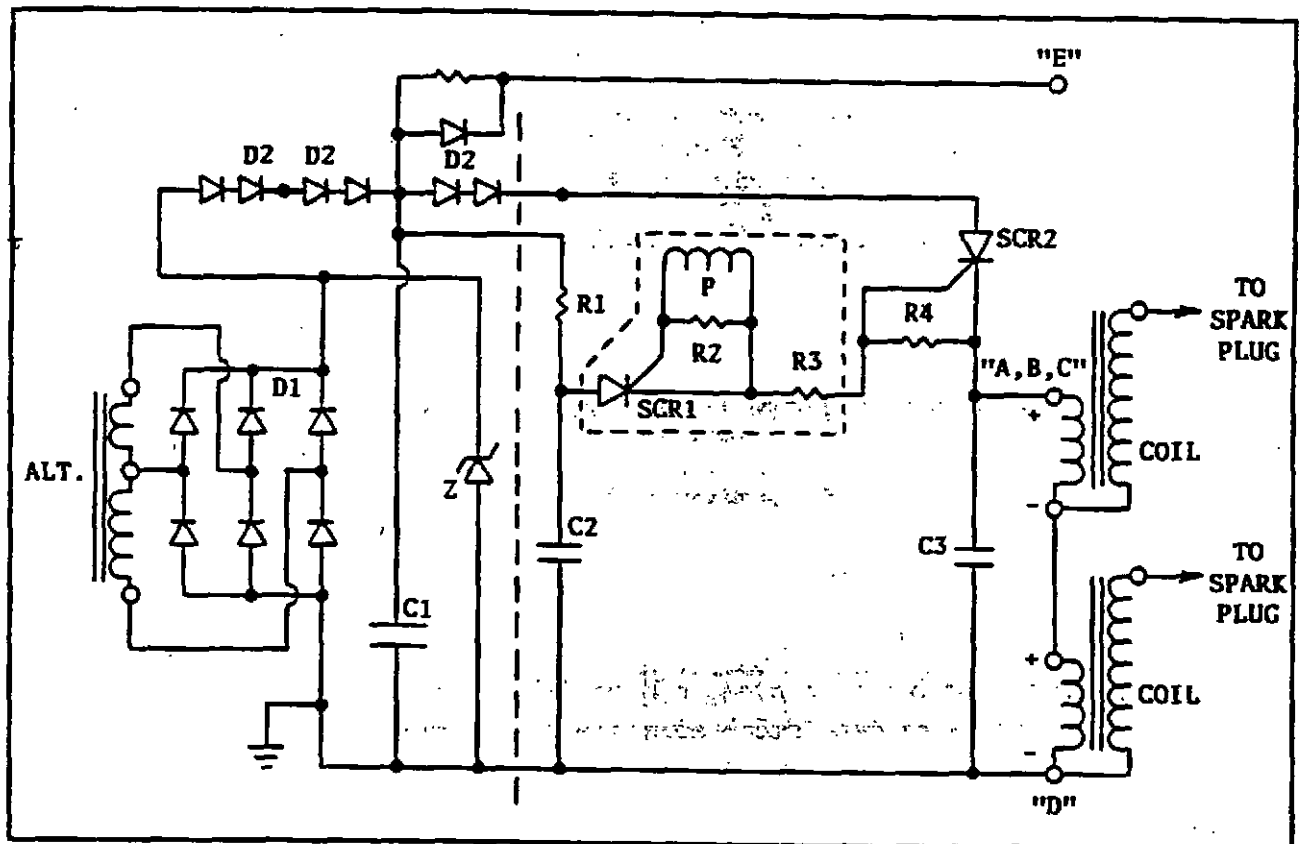

- D. Components:
- | | |
|--------------------------------|---------------------------------------|
| C1 - Capacitor, energy storage | SCR1, P, R2, R3 - Pick-up coil ass'y. |
| C2 - Capacitor, trigger | SCR2 - Power SCR |
| C3 - Capacitor, filter | R1 - Resistor, trig. circuit |
| D1 - Diode | R4 - Resistor, SCR gate |
| D2 - Diode, dual | Z - Zener diode |

4.2 PROCEDURE

- A. See Section 3.0-3.3 for proper electrical performance.
- B. Use Simpson model 260 meter on RX10,000 scale unless otherwise specified.
- C. First discharge all capacitors. Carefully use a screwdriver to short from the connector shell first to "E" pin on 5-pin connector or "G" pin on 7-pin connector; then to all other pins.

4.3 ONE OUTPUT DOES NOT FIRE

- A. Check that the 2-lead pick-up coil connector is fully plugged into the circuit board receptacle.
- B. Check with ohmmeter as follows: Positive lead to case; negative lead to connector pin with no output. Move the timer arm (21a) past the pick-up coil corresponding to the test connector pin ("A" is red; "B", "C", etc. follow in a CW direction from "A"); meter should pulse indicating pick-up coil output. If not, replace pick-up coil assembly (26a) - see pg. 11.
- C. If above tests are OK, replace circuit board assembly (27) - see pg. 11.

4.4 SYSTEM HAS WEAK OR NO OUTPUT

- A. Check stator (9) resistance - replace if defective - see 5.0 below.
 1. Center pin to outer pin: 450-850 ohms (RX100 scale)
 2. Center pin to other outer pin: 5000-6000 ohms
 3. Center pin to lamination core: infinite
- B. Check circuit board assembly (27) - replace if defective - see pg. 11.
 1. Positive lead to case; negative lead to "A" pin, then to "B" pin, then to "C" pin. All should pulse with a final infinite reading.
 2. Positive lead to "E" pin on 5-pin connector or "G" pin on 7-pin connector, negative lead to the case. Meter should move to final infinite reading within several seconds.

5.0 SERVICE - ALTERNATOR SECTION

- A. The unit breaks down into two major parts: the Alternator Section and the Back Cover Assembly. Remove the four back cover attaching screws (42), (44) and carefully pull the back cover assembly away from the alternator housing; unplug the 3-prong internal connector.
- B. The procedures of this section require the use of an arbor press.

5.1 DISASSEMBLY

- A. Remove the phenolic spacer (15), O-ring (14) and stator (9) from the alternator housing.
- B. -AW, GVW unit ONLY - remove hardware (16a), (16b), (16c) or (17a), (17b) and sleeve (18) from the unit shaft.
- C. Drive spring pin (1a) out of coupling (1) and shaft and remove coupling.
- D. Remove screw (13), lockwasher (12), washer (11) and drive gear (10).
- E. If it is necessary to replace bearing-shaft (3), support the housing on the coupling end and press shaft out of the magnet-rotor assembly and housing.
- F. Wrap magnet-rotor assembly (7) in a cloth or paper to keep it clean.

5.2 REASSEMBLY - ALTERNATOR SECTION

- A. The procedures of this section require the use of a small arbor press.
- B. Press a new bearing-shaft (3) into housing (4) until it bottoms against shoulder. Housing (4) should be supported behind the internal shoulder (tool no. 506 101B). Push on the outer race of the bearing with tool no. 506 101A.
- C. Clean all debris from the magnet-rotor assembly (7).
- D. Slide magnet-rotor assembly (7) over shaft with plate facing out as shown. Support the shaft on the coupling end (tool no. 506 102B) and press magnet-rotor assembly (7) on the shaft .575" past the shoulder for the drive gear (use tool no. 506 102C).
- E. Slide coupling (1) on the shaft and secure with spring pin (1a) through the coupling and shaft.
- F. -AW, -GVW UNIT ONLY - Install sleeve (18) and engine gear. Secure with hardware (16a), (16b), (16c) or (17a), (17b) - see page ????.
- G. Inspect gear (10); replace if worn. Secure with new hardware (11), (12) and (13).
- H. Reinstall stator with leads at the 6 o'clock position, a new O'ring (14) and the spacer (15).

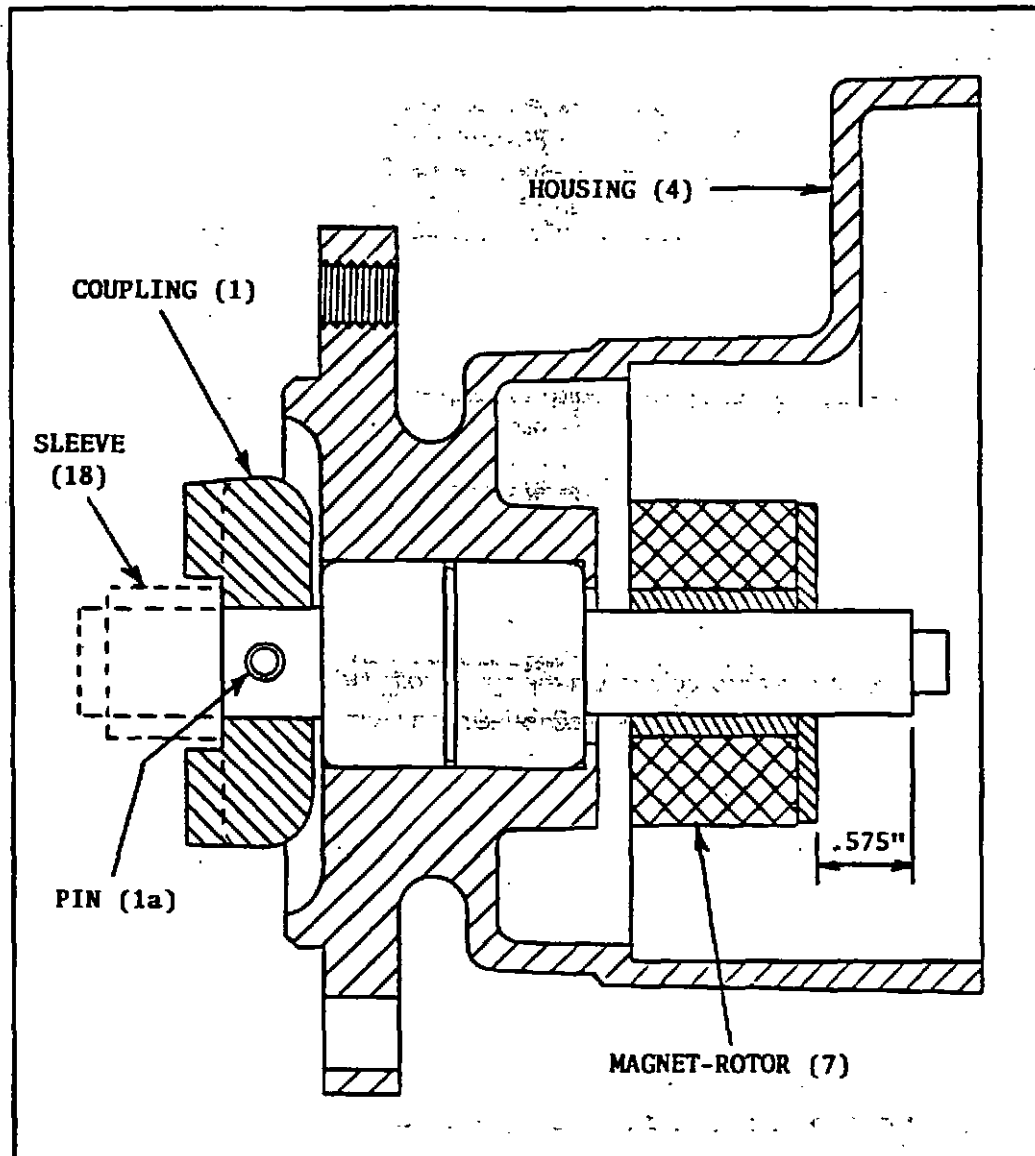

6.0 SERVICE - BACK COVER ASSEMBLY

- A. Replace only those parts requiring service.

6.0 CIRCUIT BOARD ASSEMBLY (27) - REPLACEMENT

- A. Use a small screwdriver to pull the circuit board receptacle levers away from the 2-lead housing of the pick-up coil connectors; then unplug the pick-up connectors from the circuit board (27).
 - B. Remove four screws (43), zener diode nut (27b), screw (34), washer (33) and nut (32). The circuit board can then be removed from the cover. Keep track of spacer (30).
 - C. Reverse steps 5.1A. and 5.1B. to reassemble.
- NOTE: Use part no. 902 602 (aluminum) for washer (330).

6.2 PICK-UP COIL ASSEMBLY (26a) - REPLACEMENT

- A. Remove hardware (19), (12), (11) holding the driven gear/magnet-arm assembly. Pull driven gear/magnet-arm assembly (21) from the driven shaft.
- B. Unplug the pick-up coil connector in question - see 5.1A.
- C. To replace a pick-up coil (26a), remove three screws (26e) and plate assembly (26c). On 1-cylinder units only, remove small snap ring (26f). Then remove the pick-up coil in question.
- D. When installing the new pick-up coil, the end with the green line must face out against plate (26c). Rotate the coil body so that the bulge does NOT face inside the circle of the O.D. of the bearing (31a) - see orientation in the drawing below.
- E. To reinstall top plate (26c), insert screws (26e) through plate (26c) and spacers (26d) into the plate-core assembly (26b); then tighten screws (26e).
- F. Plug in the pick-up coil connector into the circuit board receptacle.

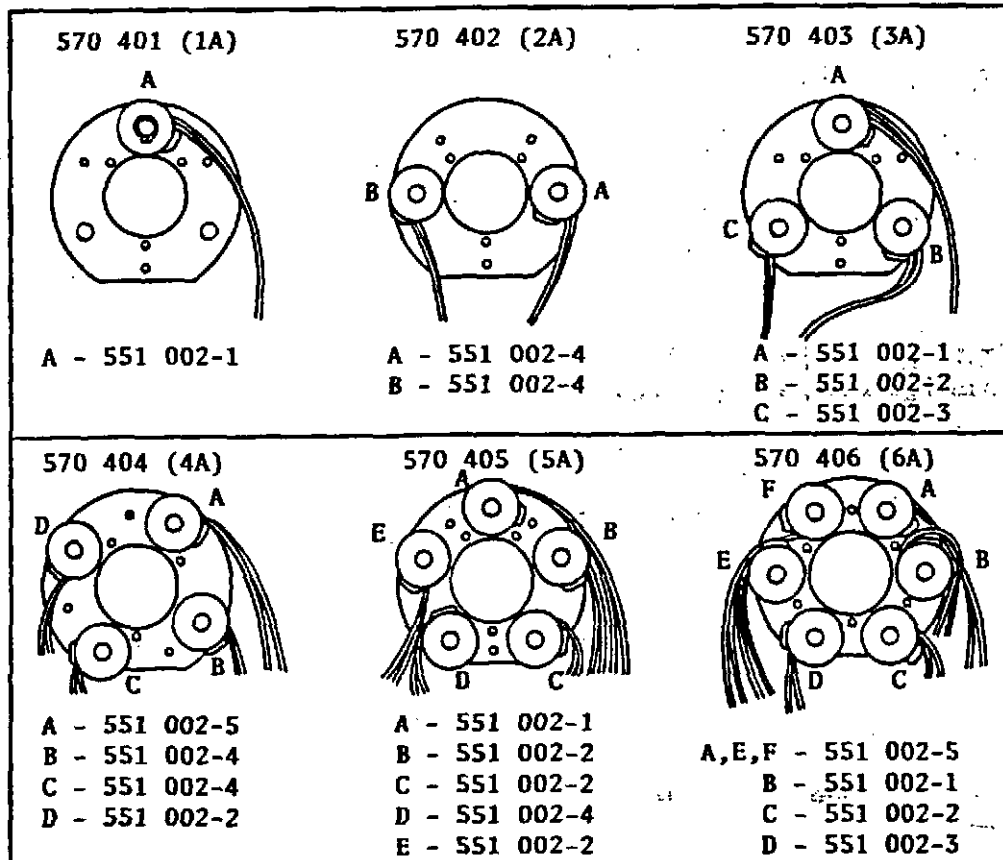

6.3 DRIVEN GEAR/MAGNET ARM ASSEMBLY (21)

NOTE: Earlier assemblies having the driven gear held to the magnet-arm with slotted pan-head screws should be updated to the equivalent one-piece driven gear/magnet-arm assembly (21).

- A. Remove screw (19) and pull driven gear/magnet-arm assembly (21) from shaft (31b). DO NOT loosen the three small button-head, hex-socket screws holding the gear assembly together. Keep track of shim washers (47).

6.4 DRIVEN SHAFT (31b), BEARING (31a).

NOTE: It is recommended that all units be updated to the current design press-fit secured driven shaft (31b).

- A. The procedures of this section require the use of a small arbor press.
- B. Remove the driven gear assembly (21) per section 6.3.
- C. Unplug the pick-up coil connectors - see step 6.1A.
- D. Remove three screws (25) and lockwashers (20). Then pull the entire pick-up plate assembly (26) off bearing (31a).
- E. Remove cover plate (39) and timing decal (37).
 - SNAP-RING SECURED DRIVEN SHAFT - Remove snap ring (91) and pull driven shaft assembly (90) from bearing (31a).
 - PRESS-FIT SECURED DRIVEN SHAFT - Press shaft (31b) out of bearing (31a).
- F. Press bearing (31a) out of rear housing (310).
- G. Support housing (31) with tool 506 103B; slide bearing (31a) over guide of tool no. 506 103B and press bearing into housing with tool no. 506 103A until it bottoms.
- H. Support bearing (31a) on the inner race (tool no. 506 104B) and press on the gear shoulder of current design shaft (31b) until shaft bottoms against bearing (use tool no. 506 104A).

6.5 REASSEMBLE BACK COVER ASSEMBLY

- A. Reinstall the pick-up plate assembly (26) and secure with hardware (20) and (25).
- B. Plug in the pick-up connectors into the circuit board receptacles.
- C. Slip shims (47) - the same number as removed, if any - over the end of the shaft (22) against shoulder. Install the driven gear assembly (21) on the shaft and secure with hardware (11), (12) and (19).
- D. Check that the air gap between the rotating arm and the plate (26c) is .005"-.018". If the air gap requires adjustment, first remove screw (19) holding the driven gear and pull the assembly (21) from the shaft. Add or subtract a shim washer (47) to increase or decrease the air gap. Reinstall assembly (21) and secure with hardware (11), (12) and (19).
- E. Using a small brush, apply a thin coat of silicone compound (GC type 5Z; Altronic part no. 503 259) to the teeth of the driven gear (21).
- F. Install washer (35), timing decal (37), lockwasher (12) and screw (19) but tighten screw so that the lockwasher just starts to compress.
- G. Place the timing arm (21) centered on the red pick-up coil core. The red mark on decal (37) should then be placed midway between the CCW and CW marks of the label. Tighten screw (19).
- H. Install cover plate (39) and secure with two screws (40).

6.6 REASSEMBLY - BACK COVER ASSEMBLY TO ALTERNATOR SECTION

- A. Mate the back cover assembly with the timing mark for the proper rotation to the alternator section with the coupling angle set as given below.
- B. Secure the back cover to the alternator with hardware (41), (42) and (44).

UNIT NO.	COUPLING		ANGLE
	CCW		CW
1A18-GV	0		-
1A28-A	0		70
2A14-A, GV	0		70
2A14-AW, GVW	-		70
2A14-D	-		0
2A18H-GV	-		70
2A25-A	-		70
2A28-A, GV	-		70
2A64-GVW	-		70
3A14-A, GV	0		70
3A14-D	-		0
3A25-GV	0		-
3A35-A	-		70
3A64-A, GV	0		70
3A64-AM	-		45
3A64-AW, GVW	-		70
4A24-A, GV	0		70
4A24-AW, GVW	-		70
4A24-D	-		0
4A34-GVW	-		70
5A24-GV	0		-
6A24-D	-		0
6A24-GV	0		-
6A34-A, GV	0		70
6A34-AM	-		45
6A34-AW, GVW	-		70

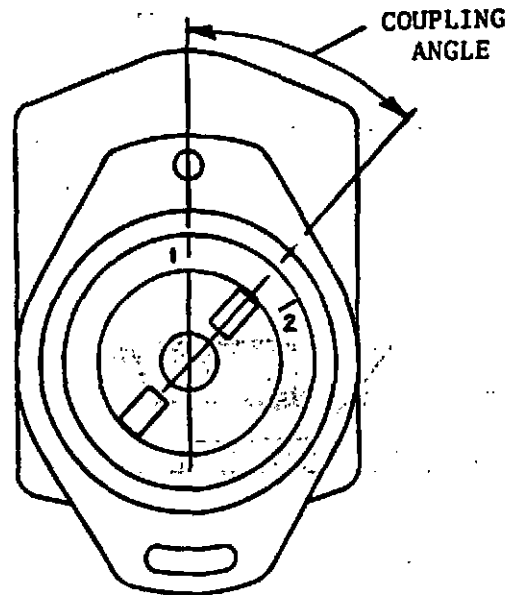

7.0 SERVICE - ASSEMBLY TOOLS

- A. The assembly tools referred to in sections 5.2 and 6.4 are available from Altronic. Alternatively, they may be fabricated from drawings provided by Altronic; request form AAT.

8.0 OPERATIONAL TEST

- A. Perform the tests following the guidelines of sections 3.0 through 3.3.
- B. Run the Operating Test of section 3.2B. for one hour.
- C. After the one hour Operating Test, check the unit timing per section 3.3.

NOTE: DEVIATION FROM THESE INSTALLATION INSTRUCTIONS MAY LEAD TO IMPROPER ENGINE OPERATION WHICH COULD CAUSE PERSONAL INJURY TO OPERATORS OR OTHER NEARBY PERSONNEL.

DESCRIPTION

The 581 603-a, -2 electronic timing units are designed for applications such as dual-gas or dual-load requiring two different timing settings. The adjustment screw is used to set the differential up to a maximum of 13 degrees, 2-cycle or 26 degrees, 4-cycle. The 581 603 series units must be used with Altronic V units having the "T" option back cover; these have the second connector (3-pin) in addition to the regular harness connector.

INSTALLATION

Mount the 581 603 unit so that connections will be protected from weather and the maximum temperature exposure does not exceed 150°F. (65°C). The following specific details are essential to proper operation of the 581 603 device (refer to the Wiring Diagram):

1. All connections to the 581 603 unit MUST be made with 24 AWG conductor, .032" insulation wire (Altronic part no. 603 102). This is the wire in the Altronic supplied cables 593 050 and 593 052. This applies to the leads from the Altronic V 3-pin connector AND to leads running from the 581 603 unit to any relay or switch device.
2. The leads to the 581 603 unit from the Altronic V unit must not exceed 25 feet (7,6m). The leads from the 581 603 unit to a switch or relay must not exceed 24 inches (610mm).
3. All wiring to the 581 603 unit MUST be kept separate from all other wiring. DO NOT bundle together timing unit wires with any other wires.
4. The case of the 581 603 box must be grounded to engine ground. It is recommended that panel ground or a separate engine ground be used. DO NOT connect the box directly to the ignition system common coil ground.
5. Consult the application chart for instructions regarding the "V" terminal. It is essential for proper operation and to achieve the proper timing range for a given application that the "V" terminal be either left open-circuited or grounded per the application chart (see back side).

INSTALLATION DIAGRAM

MOUNTING:

- 1) MOUNT 581 603 UNIT SO THAT CONNECTIONS ARE PROTECTED FROM WEATHER.
- 2) CASE OF BOX MUST BE CONNECTED TO ENGINE GROUND.
- 3) MAX. TEMPERATURE IS 150° F. - 65° C.

TIMING ADJUSTMENT:

- A) MANUAL ADJUSTABLE TIMING - CONTACTS ARE NOT USED. SET THE IGNITION TIMING 6° ADVANCED FROM THE MOST ADVANCED DESIRED TIMING. TIMING ADJUSTMENT SCREW IS USED TO VARY IGNITION TIMING. SEE CHART FOR RANGE.
- B) TWO PRE-SET TIMING POINTS - WIRE TERMINALS A AND B TO SWITCH OR RELAY CONTACTS AS SHOWN. SET THE DESIRED ADVANCED IGNITION SYSTEM TIMING IN THE NORMAL MANNER AT OPERATING RPM WITH THE CONTACTS CLOSED. THEN OPEN THE CONTACTS AND TURN TIMING ADJUSTMENT SCREW TO SET THE DESIRED RETARDED TIMING. SEE CHART FOR DIFFERENTIAL RANGE.

NOTE:
FOR CONNECTIONS TO SWITCH CONTACTS USE LEFTOVER WIRE FROM HARNESS 323 050 OR 593 052 (ALTRONIC P/N 603 102) 24 AWG CONDUCTOR, .032" INSULATION.

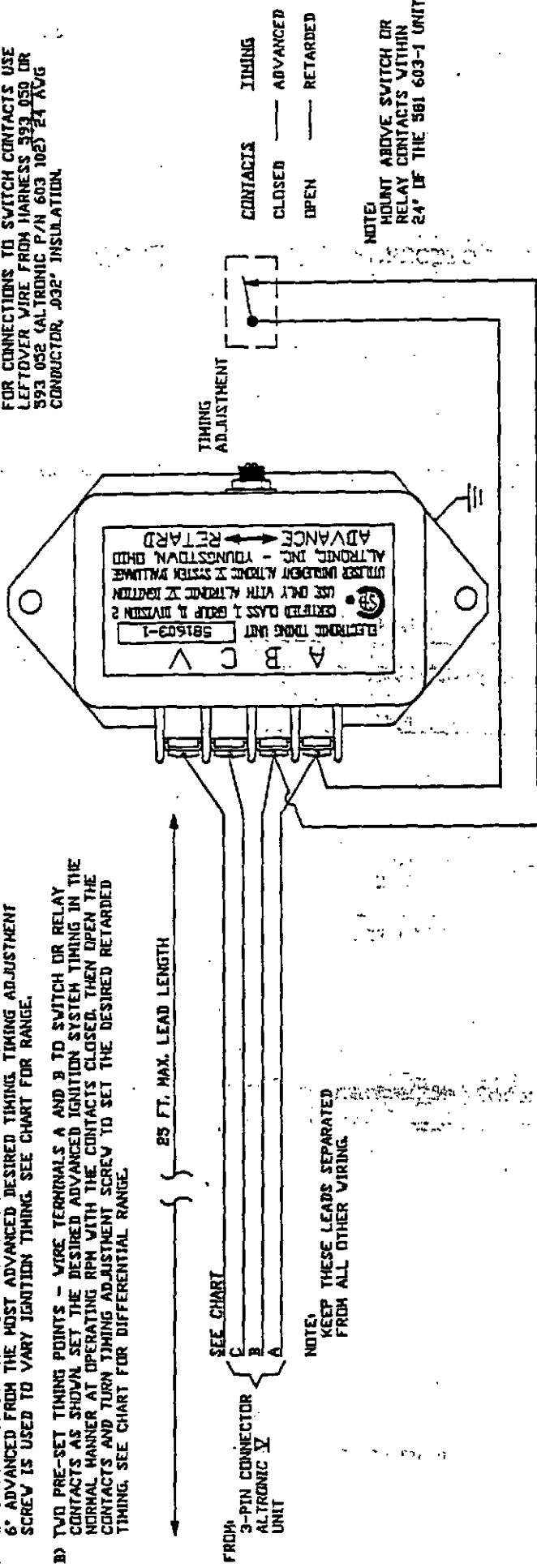

TIMING SETTING AND ADJUSTMENT

There are two ways the 581 603 electronic timing unit can be used:

- A. **MANUAL ADJUSTABLE TIMING** - Install the Altronic V unit with the back cover timing marks lined up and with the engine set 7 degrees advanced from the most advanced desired timing. With the 581 603 installation complete, use the TIMING ADJUSTMENT screw to vary ignition timing to the desired setting at the normal engine operating RPM. See the Application Chart below for the range for the specific Altronic V unit.
- B. **TWO PRE-SET TIMING POINTS** - Wire terminals A and B to a switch or relay contacts as shown in the Wiring Diagrams. With the relay or switch contacts CLOSED and the engine running at normal operating RPM, set the desired ADVANCED ignition system timing by adjusting the Altronic V unit or coupling in the normal manner. Then OPEN the contacts and turn the TIMING ADJUSTMENT screw to set the desired RETARDED timing. The differential range is shown in the Application Chart below for the specific Altronic V unit.

APPLICATION CHART - 581 603 SERIES

ELECTRONIC TIMING UNIT	ALTRONIC V MODEL	"V" TERMINAL	TIMING RANGE		ENGINE TYPE
			MANUAL (A)	TWO-POINTS (B)	
581 603-2	6A34	To Ground	20°	6° - 26°	4-cycle

OPERATION

PRELUDE TO OPERATION

This series of Hercules GTA4800 Engine consists of a turbo-charged, aftercooled six cylinder model.

The book has been compiled for your use in obtaining the maximum efficiency and trouble-free operation which have been built into your engine by Hercules craftsmanship.

Should you have a particular problem not covered in this book, we invite you to write to Hercules Engines, Inc., Service Dept., P.O. Box 24101 - Canton, OH 44701, U.S.A., whose experienced personnel will be pleased to assist you.

PRECAUTIONS- READ BEFORE STARTING THE ENGINE

This section covers those items which are of particular interest to the operator and does not cover such work as might be required of a maintenance crew. This does not mean that an operator should not acquaint himself with the various subjects covered in other sections of this book.

THE FOLLOWING PRECAUTIONS, IF FOLLOWED, WILL HELP ELIMINATE OPERATING DIFFICULTIES AND ABNORMAL WEAR:

1. **FILTERS**--Keep them clean - they are the guardians of your engine. Dirty filters cause rapid wear and low engine power output.

2. **LUBRICATING OIL**--Keep it clean - drain the crankcase often. Use the best brands obtainable.

3. Do not allow the oil level to fall below the full mark on the dipstick. Do not fill above the full mark on the dipstick.

4. Do not run the engine at any time without lubricating oil and cooling solution (water and anti-freeze mixture.)

5. Never run the engine with the coolant solution boiling. This allows lubrication to break down and may seriously damage the engine.

6. Do not put cold water in an overheated engine. It may crack the cylinder head, block, etc.

7. Never allow your batteries to run low or dry of water. In cold weather, do not fill batteries with water when shutting down as this makes them more subject to freezing.

8. Do not attempt starting the engine until the lubricating oil, water, and fuel supplies have been checked.

9. Do not run the engine at high speed without load, as this will cause undue wear and shorten the engine's life.

10. Do not idle the engine for long periods. It is not only detrimental to the engine, but also increases operating costs.

11. Never allow the engine to run without sufficient oil pressure showing on the gauge. Damage from lack of lubrication will result.

12. Do not attempt to make repairs or adjustments to the fuel system unless you are familiar with it.

13. Correct fuel pressure and volume are essential to efficient operation.

14. Never run the starting motor longer than 15 seconds at one time without a rest period of at least one minute before allowing it to run again. Failure to follow this procedure may result in a burned out starting motor.

15. Do not attempt to start or operate this engine without first reading the instructions in this book carefully. As an operator, you owe it to yourself.

STOPPING THE ENGINE

1. Stopping is generally effected by turning the key to the off position.

INSPECTION OR ADJUSTMENTS TO BE MADE DAILY:

1. Go over the entire engine daily to make sure there are no loose bolts, nuts, screws, electrical connections or parts and, also, stop all fuel, lubricating oil and water leaks. There will probably be very little tightening needed, but one loose part can cause serious damage.

2. Check the lubricating oil level in the engine and keep filled to the full mark on the gauge.

3. Air cleaners should be inspected and cleaned before starting the days run. If the engine is working in extreme dusty atmosphere, it may be necessary to clean these units more often than the regular Scheduled Maintenance Intervals.

4. The water circulating system probably receives less attention and care than any part of the engine installation, and yet it is one of the most important units. Water should be checked daily to make up for that lost in evaporation.

Also, observe if scale or sediment is forming in the cooling system; if it is, obtain water from a supply which will not cause these troubles. If the water pump is leaking, replace the seal. 50/50 mixture.

INSPECTION OR ADJUSTMENTS TO BE MADE AFTER EACH 125 HOURS OPERATION

1. Inspect and adjust the fan belts, if loose.

2. Check the spark plug gap.

3. Inspect the radiator and clean, if clogged or shows scale formation.

4. Change engine oil and oil filters.

STARTING AND OPERATING SUGGESTIONS

1. Always use single viscosity, low ash oil. This oil should be capable of meeting A.P.I. service classification, shown in Lubricating Oil Specifications.

2. Use only the best lubricating oil obtainable.

3. Mobil Pegasus 390 oil is a good grade to start with; from this, the proper grade can be determined by observing the pressure gauge and the condition of the oil at change periods.

4. Be sure all fuel line connections are tight.

STARTING THE ENGINE

SAVE YOUR BATTERIES. Two 12 volt batteries in parallel will crank the engine against compression for about six periods of 15 seconds each with a recuperation or rest of one minute between each period of cranking.

FIRST TIME THE ENGINE STARTED or starting the engine after a long period of shutdown.

1. Fill the cooling system.
2. Fill the crankcase.
3. Turn the engine over by means of the starter three or four times to start oil circulation and distribute the oil already on the surfaces.

Check the air cleaners to make sure there are no obstructions, that they are properly installed and are clean.

Check the entire electrical system to be sure there are no loose connections and all component parts are properly connected.

See that no tools, parts, etc., are lying, or on any part of the engine, as they could cause serious damage to the engine or bodily injury to anyone near.

Start the engine by operating the starting button.

Allow the engine to run for several minutes before load is applied to enable the engine to properly warm up and insure proper lubrication.

OPERATING INSTRUCTIONS AFTER STARTING

After the engine has started, an inspection of the whole engine unit should be made to make sure all parts are functioning properly.

1. Look at the lubricating oil gauge. If no pressure shows after the engine has run 10 or 12 seconds, shut down the engine and ascertain what the trouble may be. With the bearings in good condition and the proper grade of oil, the pressure should be 50 to

65 pounds at full engine speed. If the oil is very cold or heavy, this pressure may be much higher. As the oil heats up, the pressure will reduce.

2. Check the water temperature. If the water temperature is above 200°, shut down the engine to ascertain what the trouble may be. Never operate with the water boiling, as this heat on the cylinder walls breaks down the oil film and also causes considerable water loss due to steaming.

3. Observe the engine operation for smoothness, quietness and exhaust condition.

4. See that there is an adequate supply of fuel and that fuel is being delivered to the regulator.

5. Check and see that there are no oil or water leaks.

6. Observe the fan and belt operation. Loose fan belts allow slippage which reduces the efficiency of the fan and wears the belts out rapidly and, also, affects the efficiency of the water pump.

7. See that the radiator is free of obstructions between the fins or tubes as they will obstruct the air flow and reduce the cooling efficiency of the radiator unit.

STORING THE ENGINE FOR LONG PERIODS

If slushing oil is not available, clean crankcase lubricating oil heated to about 180° to 200° may be substituted. However, this does not have the protection qualities of the slushing oil and should be periodically reapplied.

A - PREPARING THE ENGINE

1. Before reinstalling the spark plugs, take a pump type oil can with a long narrow spout, with a tip that will fit into the spark plug hole, and give it six or eight squirts per cylinder, then turn the engine over slowly a few times to distribute the oil.

BEFORE STARTING, remove the spark plugs and turn the engine over with the starting motor to blow the excess oil out.

2. Drain the entire engine and water circulating system thoroughly.

3. Drain the lubricating oil from the engine and filters.

4. The crankcase should be filled to the FULL mark on the bayonet gauge. See Luboil Specification.

This oil should be placed in the engine crankcase at the beginning of the run.

The above oils are graded the same as regular motor oil according to SAE weight. Therefore, the proper weight of oil for the climatic conditions should be chosen to facilitate starting.

5. Disconnect the wires leading to the batteries and remove the batteries, storing them preferably at some place where they can be charged periodically, as batteries lose their charge rapidly if not in use.

6. Cover the ends of the air inlet and exhaust pipe so moisture cannot reach the valve ports and cylinders, store the engine where it will not be exposed to the elements such as sun, rain, snow, hail, etc, and preferably where it can be kept warm and dry.

7. Every month the engine should be cranked over by hand eight or ten revolutions to redistribute the oil film over the wearing surfaces. This will prevent rusting of the wearing surfaces inside the engine.

The above methods have proven successful; however, Hercules Engines, Inc., can not assume responsibility for engine storage.

PREPARING THE ENGINE FOR STARTING AFTER A LONG SHUTDOWN - If the engine has been stored as outlined above, it will be necessary to pursue the following procedure to prepare it for starting again:

1. Check all fuel supply lines from the main supply to the filter to make sure the connections are tight and the lines are open with no obstruction or "pinched" places.

2. If the spark plugs do not function properly, clean as described.

3. Turn the engine by hand three or four revolutions to spread the lubricating oil on the walls and bearings and start oil circulation.

4. Install the spark plugs and connect the wires.

5. Fill the cooling system with clean water or an antifreeze solution.

6. Follow the instructions as given for "Starting the Engine for the First Time."

7. After the engine is running, follow the instructions as given for "Operating Instructions After the Engine is Started."

HIGH ALTITUDE OPERATION

The starting and operation of engine encounter certain difficulties at high altitudes. These difficulties are not commonly noticeable until 3000 feet is reached. While the engine has lost only about 10 percent at 3000 feet, at 6000 feet the loss is about 21 percent. From these figures one can readily see that no difficulty will be encountered in the first 3000 feet, but that some consideration must be made in the power requirements at these higher altitudes. This fuel adjustment must be made on turbo-charged engines to prevent overspeeding of the turbo-charger.

Since air at higher altitudes is much lighter and contains less oxygen than at sea level, the amount of air or oxygen drawn into the cylinders at higher altitudes is much less. This lowers the compression pressures, causing hard starting and poor combustion.

It is necessary to reduce the amount of fuel entering the cylinder, as with the original fuel setting and the smaller amount of oxygen, the combustion is incomplete and a smoky exhaust results, with the naturally asperated engine only.

It is sometimes desirable to follow the starting methods as outlined under "Cold Weather Starting".

For additional information on specific cases, please write to Hercules Engines, Inc., Service Department, P.O. Box 24101, Canton, Ohio 44701, U.S.A., giving as much data as available.

RECOMMENDED LUBRICATING OIL SPECIFICATIONS

LUBRICATION

LUBRICATION INSTRUCTIONS

Oil Level. The level of the oil in the crankcase is determined by a bayonet or dipstick type of gauge. Wipe off the gauge and re-insert to determine the oil level accurately. The oil level should be maintained at the full mark on the gauge. See Illustration No. 4.

The engine must be stopped for at least two minutes before the oil level is checked. This will allow the oil to drain back into the oil pan and prevent overfilling.

OIL CHANGING (1ST OIL CHANGE & FILTERS AT 125 HOURS)

Frequency of oil changes depends upon the application of the engine and the severity of the operation. Under normal operating conditions the oil should be changed every 500 hours.

Lubricating oil recommendations are based on engine design, type of service, and ambient air temperature. High quality oils combined with necessary oil and filter changes are required to assure maximum performance, long engine life, and minimum operating costs.

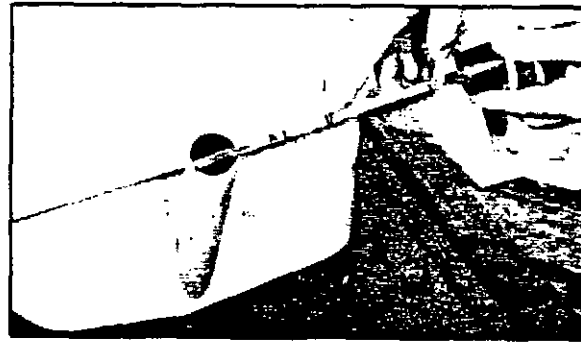

Illustration No. 4

The filter element should be changed at the same time the oil is changed in the crankcase. Re-check the oil level after running the engine approximately five minutes to fill the filters. Use the bayonet gauge when replenishing the oil supply and fill to the full mark on this gauge. See "Oil Level".

ACCESSORIES

Accessories mounted on the engine usually carry their own lubricating instructions, which should be followed.

Check oil level at every oil change. Remove plug as shown below, if oil drips out, oil is at its proper level. Use SAE #20 oil. Remove oil fill cap and pour oil in until it drips out of the sight hole. Coat plug with teflon (or equal), and tighten securely.

Oil fill cap. Use SAE #20 oil.

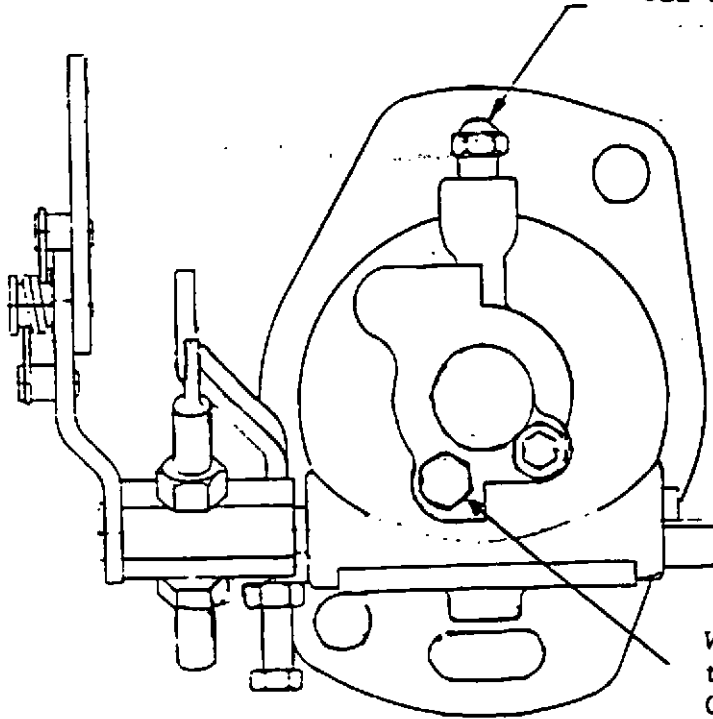

With engine stopped, remove this plug to check oil level. Oil is at proper level if it drips out.

NOTE: COAT PLUG WITH TEFLON (OR EQUAL) WHEN REPLACING PLUG.

OIL PRESSURE

Refer to "Oil Pressure." See Engine Name Plate.

SUGGESTED PREVENTIVE MAINTENANCE SCHEDULE

A. DAILY

1. Check air cleaner.
2. Check crankcase oil level.
3. Check coolant level.
4. Check alternator charge.
5. Check oil pressure reading.
6. Check general condition of unit. Tighten, repair, or replace parts as necessary.

B. 125 HOURS OR 3000 MILES IN ADDITION TO "A" SERVICES.

1. Change crankcase oil, and oil filters.
2. Clean crankcase breather.
3. Tighten accessory drive belts.
4. Check spark plug gap.
5. Check radiator air passages for air flow restrictions, dirt chaff, etc. Clean, if dirty.

C. 500 HOURS OR 12000 MILES. IN ADDITION TO "B" SERVICES

MAJOR TUNE-UP

1. Inspect engine for loose connections, leaks in oil, fuel and water system, cracks, and free action of all moving parts.
2. Check valve tappet clearance and reset, if necessary.
3. Adjust governor and throttle linkage.

4. Change air filter.

5. Change spark plugs.

6. Check timing and adjust, if necessary.

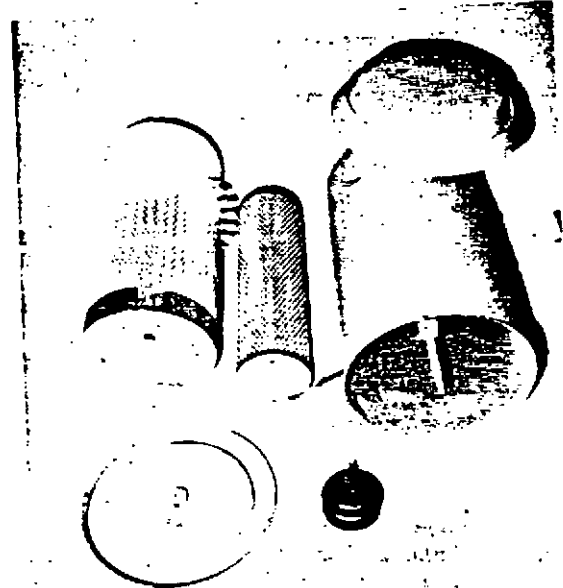

Illustration No. 5



Illustration No. 6

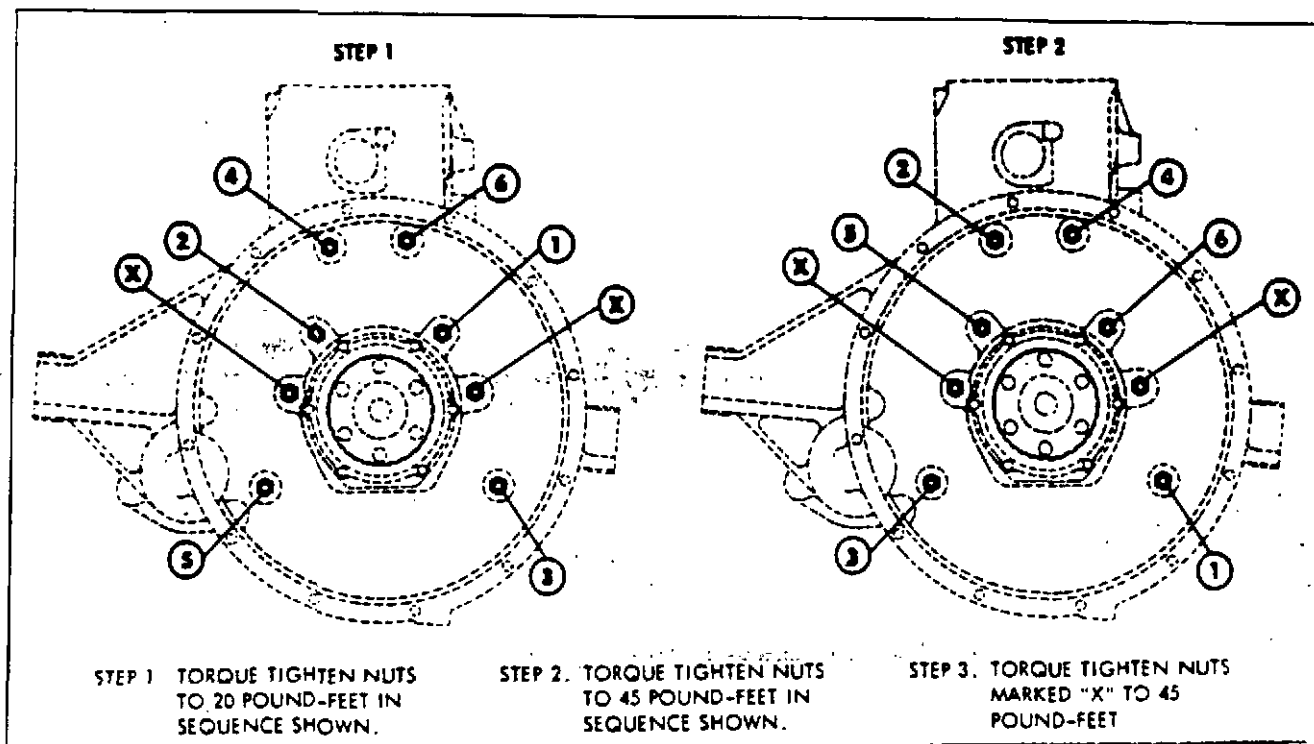

Illustration No.

TO REMOVE THE BELLHOUSING

1. Remove the clutch or power take-off mechanism.
2. Remove the flywheel. See "Flywheel", Illustration No. 21.
3. If the engine is in the unit, place suitable supports under the rear of the crankcase to support the engine.
4. Remove the rear motor support screws.
5. Remove the bellhousing attaching stud nuts. See Illustration No. 7. This also shows torquing sequence and pounds torque on nuts.
6. Pull the bellhousing away from the engine. It may be necessary to tap the housing with a soft hammer to loosen from the dowels or gaskets sticking to the block.
7. Inspect rear crankshaft seal. Replace if necessary.

TO INSTALL THE BELLHOUSING

1. Install a new bellhousing gasket to the cylinder block, as bellhousing locating dowels and studs will hold it in place.
2. Check the bellhousing mounting dowels to be sure that they are tight and in good condition. Install bellhousing and torque, tighten nuts in sequence shown in Illustration No. 7.
3. Install the rear motor support screws and remove the jack or block from under the crankcase.
4. Install the flywheel. See "Flywheel", Illustration No. 21, and "Indicator", Illustration No. 22.
5. Install the clutch or torque converter.

DESCRIPTION AND MAINTENANCE

This section covers a brief description and function of the various parts of the engine along with complete instructions covering the repair, disassembly and reassembly of the various component parts of the G4800 Series engine.

This section has the various subjects arranged alphabetically for convenience in locating.

AIR CLEANERS

Dirt is the greatest enemy of any internal combustion engine and it is necessary to take every precaution to prevent it from entering the engine. This is accomplished by using an efficient dry type air cleaner. When dirty, a restriction is created in the air intake, which may cause excessive exhaust smoke, loss of power, excessive fuel consumption, internal engine deposits and result in short engine life. Very little restriction, due to dirty air filters, is sufficient to create a very rich mixture. Therefore, one of the most essential preventive measures is proper maintenance of the air intake filter. This unit should be checked at least once a day and, if operating in dusty conditions, may require cleaning or servicing of the elements even more often. Single element style cleaners are used in normal applications.

When an Air Restrictor Indicator, either electrical or vacuum type is used, it will flash or show a red signal when the air intake has become clogged. If the air stack cap, or precleaner screener has been kept clean, indication will be that the air cleaner element should be serviced. Do not exceed 15" H₂O intake air restriction.

All connections between the air cleaner and manifolds must be absolutely air tight. Abrasive laden air drawn into the engine through a loose connection will cause rapid wear of the pistons, rings and upper cylinder surfaces.

BREATHER

The breather allows accumulated gases to escape from the crankcase, the normal process of engine breathing. The engine is equipped with a draft tube to eliminate these gases.

BELLHOUSING

The bellhousing is an aluminum casting which fastens to the rear end of the cylinder block. The bellhousing forms a complete enclosure for the flywheel and clutch, to which the transmission, torque converter or other drive mechanism is attached. The bellhousing also forms the rear motor support.

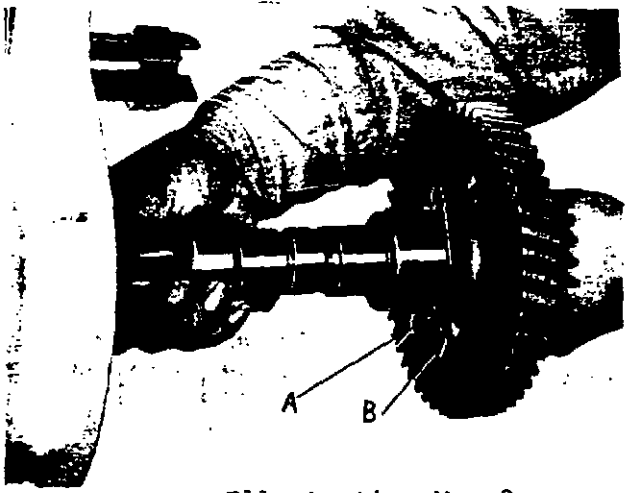

Illustration No. 8

CAMSHAFT

The camshaft is supported on large diameter pressure lubricated removable bearings in the crankcase and is driven by means of a suitable gear which meshes with the crankshaft gear.

The timing of these two gears requires no check of the valve position. It is only necessary to align the two punch marks on the cam gear with the one mark on the crank gear.

The camshaft end play is controlled by a thrust plate (A), Illustration No. 8, located between the front camshaft bearing and the camshaft gear. Correct end play of .006 to .015 is regulated by the thickness of the thrust plate.

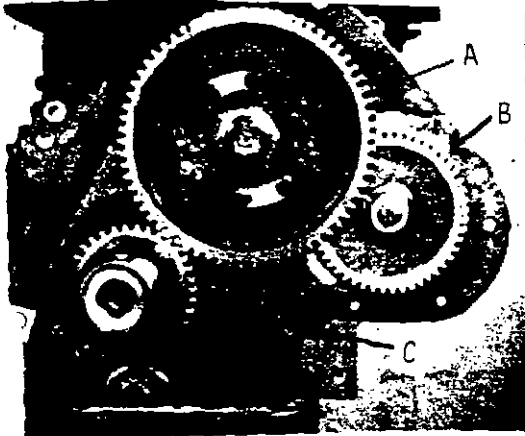

To decrease the end play when it is beyond specified limits. Replace thrust plate "A", see Illustration No. 8.

To increase the end play, use a piece of very fine emery or Crocus cloth on a surface plate, polish the thrust plate

to the desired thickness to obtain the proper end thrust.

TO REMOVE THE CAMSHAFT, OR CAMSHAFT GEAR.

Assuming that the radiator, and so forth have been removed, the camshaft may be removed as follows without removing the engine from the chassis.

1. Remove the fan blade and belts for easier access to the gear cover and gears.
2. Remove the fan drive pulley nut, fan drive pulley, and vibration damper assembly.
3. Remove the gear cover.
4. Remove the rocker arm covers, rocker arms and push rods.
5. Remove lube oil filters and cooler assembly.
6. Remove side cover plates and lift out tappets keeping them in same order as removed for reassembling in same position.

NOTE: To remove and assemble the camshaft to the engine with the engine out of the chassis, the same procedure is followed, except Item No. 5 and No. 6 are disregarded. With the engine out of the chassis, it is only necessary to set the engine on the bellhousing, push the tappets to the "up" position and remove the camshaft. With the tappets in the raised position, rotate the engine until the two holes in the camshaft gear expose the thrust plate attaching screws.

7. Remove the thrust plate attaching screws and pull the camshaft forward out of the engine block.

Inspect the camshaft lobes, journals, etc., for wear or damage. Also, inspect the thrust plate for clearance.

NOTE: To remove the camshaft gear, the cam assembly must be removed from the cylinder block. The gear must be heated and pressed off.

**Crankshaft Thrust Bearing Journal, Crankshaft Pulley End,
Crankshaft Gear, and Crankshaft Damper and Pulley Wear Limits**

Index Number	Item/Point of Measurement	Size and Fit of New Parts (inches)	Wear Limit (inches)
3	Crankshaft main thrust bearing journal width	2.1370 to 2.1390	2.1420
5	Crankshaft pulley end rear outside diameter	2.2492 to 2.2498	None
6	Crankshaft gear inside diameter	2.2495 to 2.2500	None
7 and 5	Fit of crankshaft gear on rear of crankshaft pulley end	0.0003T to 0.0008L	None
8	Crankshaft damper and pulley bore diameter	2.2478 to 2.2484	None
10	Crankshaft pulley end front outside diameter	2.2487 to 2.2492	None
9 and 10	Fit of crankshaft damper and pulley on front of crankshaft pulley end	0.0003T to 0.0014T	None

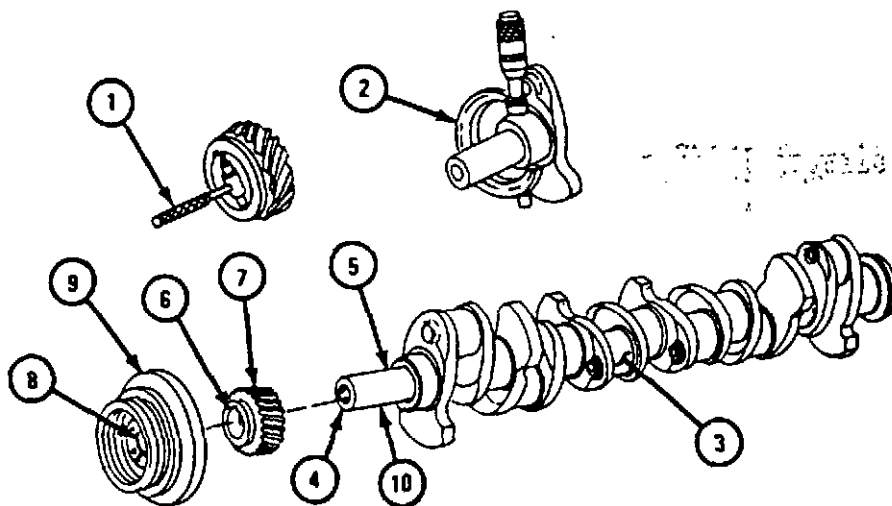

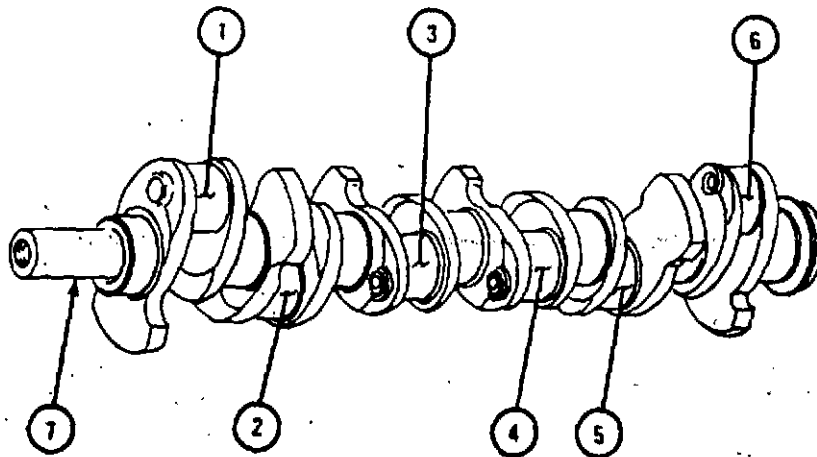

Standard Size Crankshaft Connecting Rod Journals Wear Limits

Index Number	Item/Point of Measurement	Size and Fit of New Parts (inches)	Wear Limits (inches)
1 through 6	Connecting rod journal outside diameter	2.9970 to 2.9980	2.9950

0.0100-Inch Undersize Crankshaft Connecting Rod Journals Wear Limits

Index Number	Item/Point of Measurement	Size and Fit of New Parts (inches)	Wear Limit (inches)
2 through 6	Connecting rod journal outside diameter	2.9870 to 2.9880	2.9850

0.0200-Inch Undersize Crankshaft Connecting Rod Journals Wear Limits

Index Number	Item/Point of Measurement	Size and Fit of New Parts (inches)	Wear Limit (inches)
1 through 6	Connecting rod journal outside diameter	2.9770 to 2.9780	2.9750

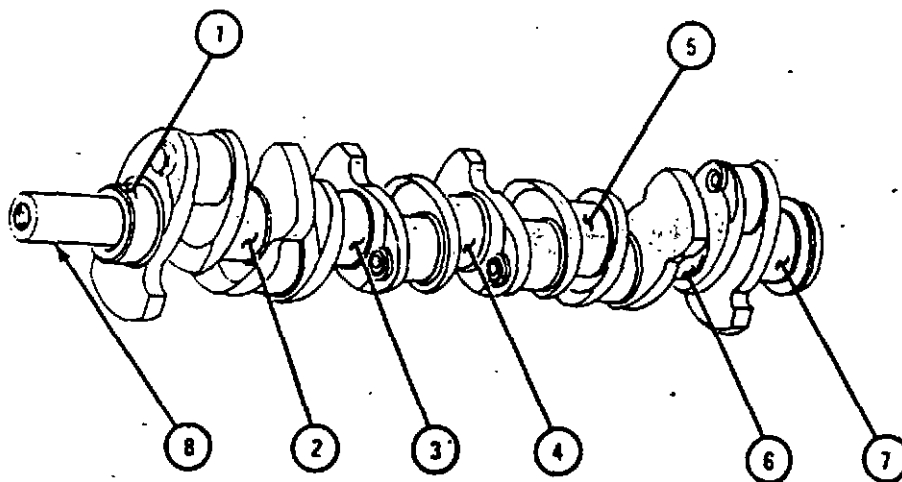

Standard Size Crankshaft Main Bearing Journals Wear Limits

Index Number	Item/Point of Measurement	Size and Fit of New Parts (inches)	Wear Limits (inches)
1 through 7	Main bearing journals outside diameter	3.6210 to 3.6220	3.6190

0.0100-Inch Undersize Crankshaft Main Bearing Journals Wear Limits

Index Number	Item/Point of Measurement	Size and Fit of New Parts (inches)	Wear Limits (inches)
1 through 7	Main bearing journals outside diameter	3.6110 to 3.6120	3.6090

0.0200-Inch Undersize Crankshaft Main Bearing Journals Wear Limits

Index Number	Item/Point of Measurement	Size and Fit of New Parts (inches)	Wear Limit (inches)
1 through 7	Main bearing journals outside diameter	3.6010 to 3.6020	3.5990

CONNECTING ROD

The connecting rods are heavy alloy steel forgings with precision type bearings for the shaft and bronze bushings for the piston pin. With this precision or insert shell type bearing, the cam and rod is split at 45° to facilitate removal. No shims are used and therefore, when reconditioning of the bearings is necessary, only the bearing shells need to be replaced.

CAUTION: Do not file or grind the caps, as new bearings cannot be installed in a connecting rod that has been filed.

NOTE: As built at the factory, the connecting rods and caps are marked on the camshaft side and to the front of the engine with the cylinder number in which they are used.



Connecting Rod

TO REMOVE THE CONNECTING RODS

CAUTION:--Connecting rods and caps are matched -- keep them paired together, as otherwise they cannot be reinstalled.

1. Drain the radiator and engine block.
2. Remove the thermostat housing and thermostat and water manifolds. Also, disconnect the water temperature gauge thermocouple.
3. Disconnect and remove the air cleaner hose from the manifold.
4. Disconnect the exhaust pipe from the manifold.
5. Disconnect the spark plug wires, and remove spark plugs.

6. Remove the front and rear cylinder head covers, rocker arm assemblies and push rods.

7. Remove the cylinder head nuts and lift the cylinder head assembly carefully from the engine (manifolds may be removed with the heads).

8. Remove the oil pan and lubricating oil pump and lines.

9. Remove the piston oil spray nozzle assembly from each cylinder.

10. Carefully scrape the carbon deposit from the top of each cylinder bore so that the pistons can be removed without damage to the rings.

11. Turn the engine so that No. 1 and No. 6 connecting rod caps can be removed and the piston and rod assembly pushed carefully upward with a block of wood or hammer handle, Illustration No. 10, to remove from the engine.

NOTE:--Keep the rod caps and bearings of each respective rod together -- do not mix.

12. Turn the engine, as required, so that the other rods and pistons may be removed.

TO DISCONNECT THE CONNECTING RODS FROM THE PISTONS.

Remove the piston pin retaining rings and push the pin out of the piston and connecting rod bushing.

Inspect the piston pin and bushing for wear and replace, if necessary. If new parts are used, check the connecting rod alignment on a standard aligning fixture.

TO INSTALL THE CONNECTING RODS.

1. Assemble the connecting rod and piston and insert the retaining rings in piston.

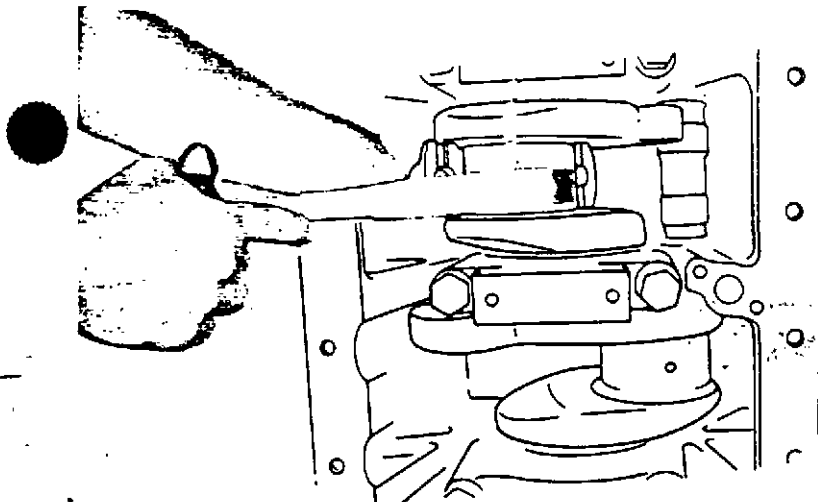

Illustration No. 10

2. Inspect the crankshaft for any rough or scored marks that might damage the connecting rod bearings. If any rough marks are found, use an oil stone, very fine emery cloth or Crocus cloth to polish the shaft. Clean the shaft thoroughly after polishing.

3. Install the piston rings on the pistons. See "Piston Rings".

4. Select the proper piston and connecting rod assembly and turn the crankshaft so that it is in the correct position.

5. Apply a liberal coat of lubricating oil to the cylinder bores, pistons, rings, and piston pin. Space the piston rings so that no two slots are in line.

6. With the piston rings compressed as shown in Illustration No. 11, use a hammer handle or block of wood to force the piston and rings into the cylinder bore. At the same time, use care that the connecting rod is in line with the crankshaft journal.

7. With the piston entirely in the cylinder bore, insert the upper bearing shell and pull the connecting rod down to the crankshaft.

8. Place the shells in the cap and assemble. Tighten the cap screws to the proper tension and try the connecting rod for side movement. It should move easily. See "Fits and Tolerances" for proper clearance and proper nut tension.

9. Repeat the above operations for all connecting rods.

10. Install the piston oil spray assembly for each piston.

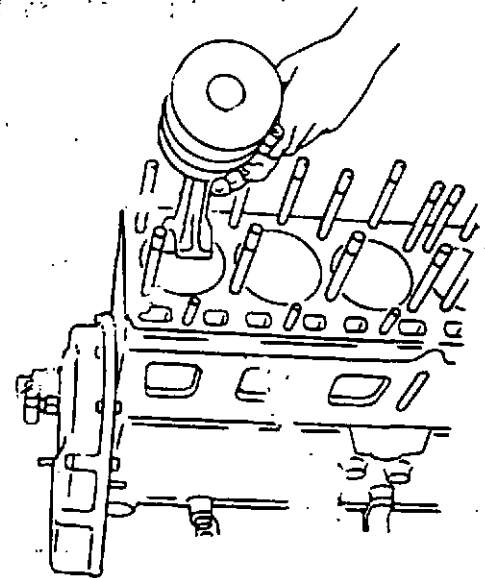

Illustration No. 11

11. Install oil pump and lines.

12. Inspect the top of the cylinder block and pistons. Be sure no foreign matter is present and install new cylinder head gaskets.

13. Install the cylinder head. See "Cylinder Head Torque", per Illustration No. 20.

14. Insert the valve push rods and install the rocker arm assemblies.

15. Adjust the tappets to the proper clearance. See "Valves".

16. Install the cylinder head cover, using a new gasket, if necessary. Install the nuts and washers as removed.

17. Install the thermostat, thermostat housing, water pump by-pass hose and connect the water temperature gauge thermocouple and water manifold.

18. Install the fuel line.
19. Install and connect the air cleaner and connect the exhaust pipe to the manifold.
20. Connect the radiator hoses and fill the radiator with clean water and antifreeze.
21. Install the oil pan, using new gaskets, and fill the crankcase with the proper grade of lubricating oil to the full mark on the dipstick.

CONNECTING ROD BEARING REPLACEMENT.

If excessive clearance develops between the shaft and bearing shells, new bearing shells should be installed. If the clearance is excessive with the new bearings, regrind the shaft and use undersized bearings. Undersized bearings are available in sizes of .010 and .020.

The connecting rod bearings may be replaced as outlined below:

1. Remove the oil pan. See "Oil Pan, Oil Pump & Oil Pump Lines".
2. Locate the crankshaft so the connecting rod cap can be removed.
3. Remove the screws.
4. With a soft hammer, tap the cap to loosen it and remove the cap.
5. Replace the bearing shells as outlined under paragraph No. 8 and No. 9 (Connecting Rod Installing).
6. Reassemble the oil pan, oil pump and lines to the engine. See "Oil Pan".

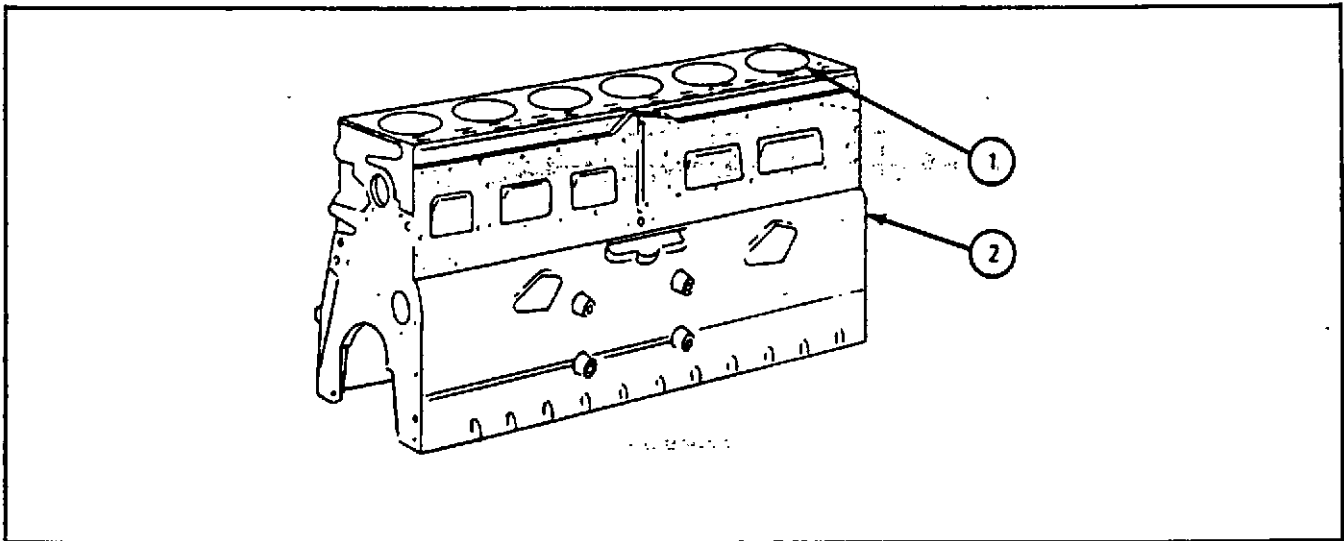

Cylinder Sleeve Wear Limits

Index Number	Item/Point of Measurement	Size and Fit of New Parts (inches)	Wear Limit (inches)
1	Cylinder sleeve outside diameter	4.7500 to 4.7510	None
1 and 2	Fit of cylinder sleeve in bore of crankcase	0.0005L to 0.0015L	None
1	Cylinder sleeve inside diameter (cylinder sleeve in crankcase)	4.5630 to 4.5645	4.5665
	<i>CYLINDER SLEEVE PROTRUSION ALLOWANCE</i>	<i>0.0005 TO 0.0050</i>	

CYLINDER BLOCK MAIN BEARING BORE 3.9370 TO 3.9380

Standard Size Crankshaft Main Bearings and Oil Clearance Wear Limits

Index Number	Item/Point of Measurement	Size and Fit of New Parts (inches)	Wear Limit (inches)
1	Main bearings inside diameter	3.6252 to 3.6272	3.6292
	Oil clearance between crankshaft main journals and main bearings	0.0032 to 0.0062	0.0080

0.0100-Inch Undersize Crankshaft Main Bearings and Oil Clearance Wear Limits

Index Number	Item/Point of Measurement	Size and Fit of New Parts (inches)	Wear Limit (inches)
1	Main bearings inside diameter	3.6152 to 3.6172	3.6192
1	Oil clearance between crankshaft main journals and main bearings	0.0032 to 0.0062	0.0080

0.0200-Inch Undersize Crankshaft Main Bearings and Oil Clearance Wear Limits

Index Number	Item/Point of Measurement	Size and Fit of New Parts (inches)	Wear Limit (inches)
1	Main bearings inside diameter	3.6052 to 3.6072	3.6092
1	Oil clearance between crankshaft main journals and main bearings	0.0032 to 0.0062	0.0080

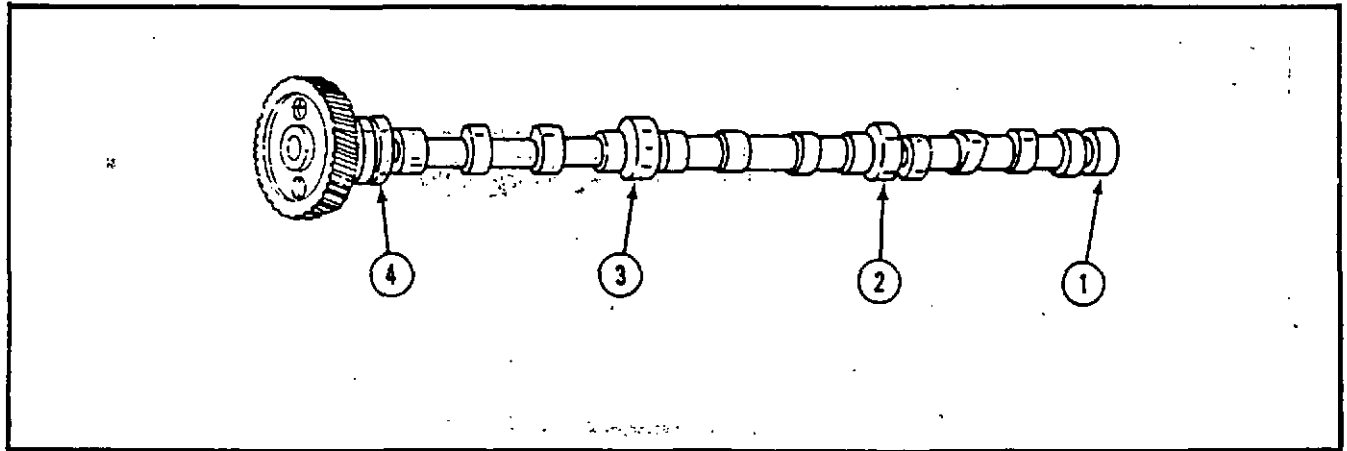

Camshaft Journals Wear Limits

Index Number	Item/Point of Measurement	Size and Fit of New Parts (inches)	Wear Limit (inches)
1	Rear camshaft journal outside diameter	1.9410 to 1.9920	1.9890
2	Rear intermediate camshaft journal outside diameter	2.3035 to 2.3045	2.3015
3	Front intermediate camshaft journal outside diameter	2.3660 to 2.3670	2.3640
4	Front camshaft journal outside diameter	2.4285 to 2.4295	2.4265

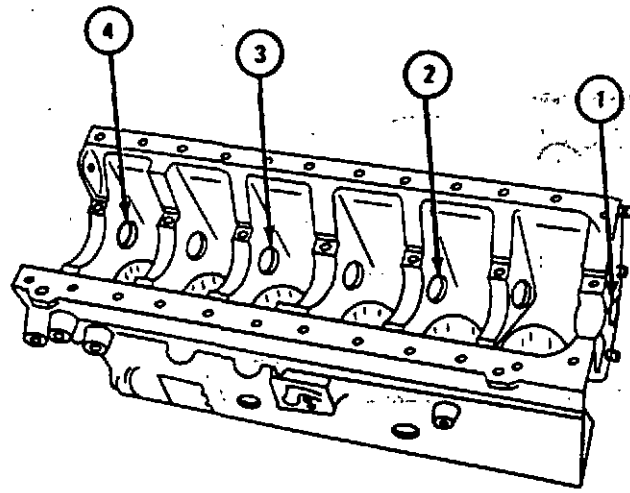

Camshaft Bearing Wear Limits

Index Number	Item/Point of Measurement	Size and Fit of New Parts (inches)	Wear Limit (inches)
1	Camshaft rear bearing inside diameter	1.9940 to 1.9950	1.9970
2	Camshaft rear intermediate bearing inside diameter	2.3065 to 2.3075	2.3095
3	Camshaft front intermediate bearing inside diameter	2.3690 to 2.3700	2.3720
4	Camshaft front bearing inside diameter	2.4315 to 2.4325	2.4345

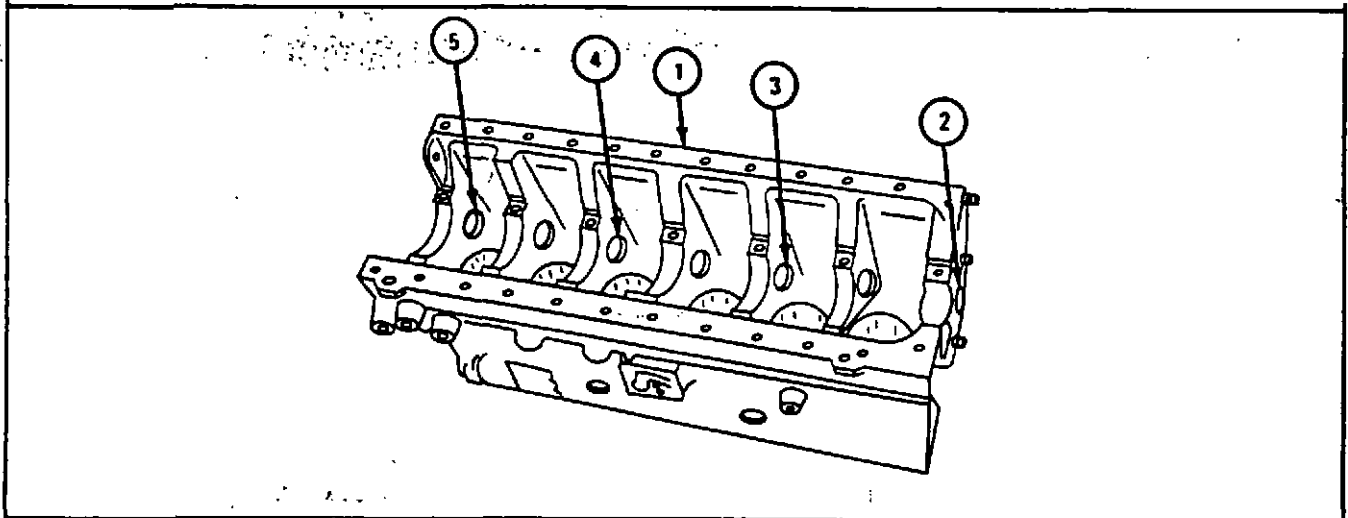

Camshaft Bearing Bore Wear Limits

Index Number	Item/Point of Measurement	Size and Fit of New Parts (inches)	Wear Limit (inches)
2	Camshaft rear bearing bore inside diameter	2.1245 to 2.1255	None
3	Camshaft rear intermediate bearing bore inside diameter	2.4270 to 2.4280	None
4	Camshaft front intermediate bearing bore inside diameter	2.4995 to 2.5005	None
5	Camshaft front bearing bore inside diameter	2.5620 to 2.5630	None

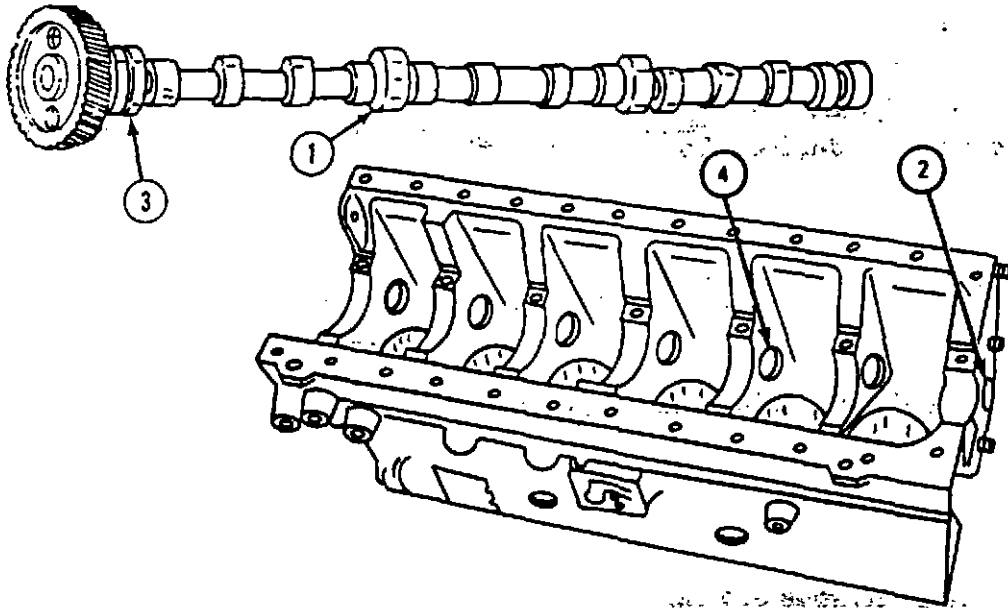

Rear Camshaft Journals and Camshaft Bearings Wear Limits

Index Number	Item/Point of Measurement	Size and Fit of New Parts (inches)	Wear Limit (inches)
1 and 2	Fit of rear camshaft journal in rear camshaft bearing	0.0020 to 0.0040	0.0060 max
3 and 4	Fit of rear intermediate camshaft journal in rear intermediate camshaft bearing	0.0020 to 0.0040	0.0060 max

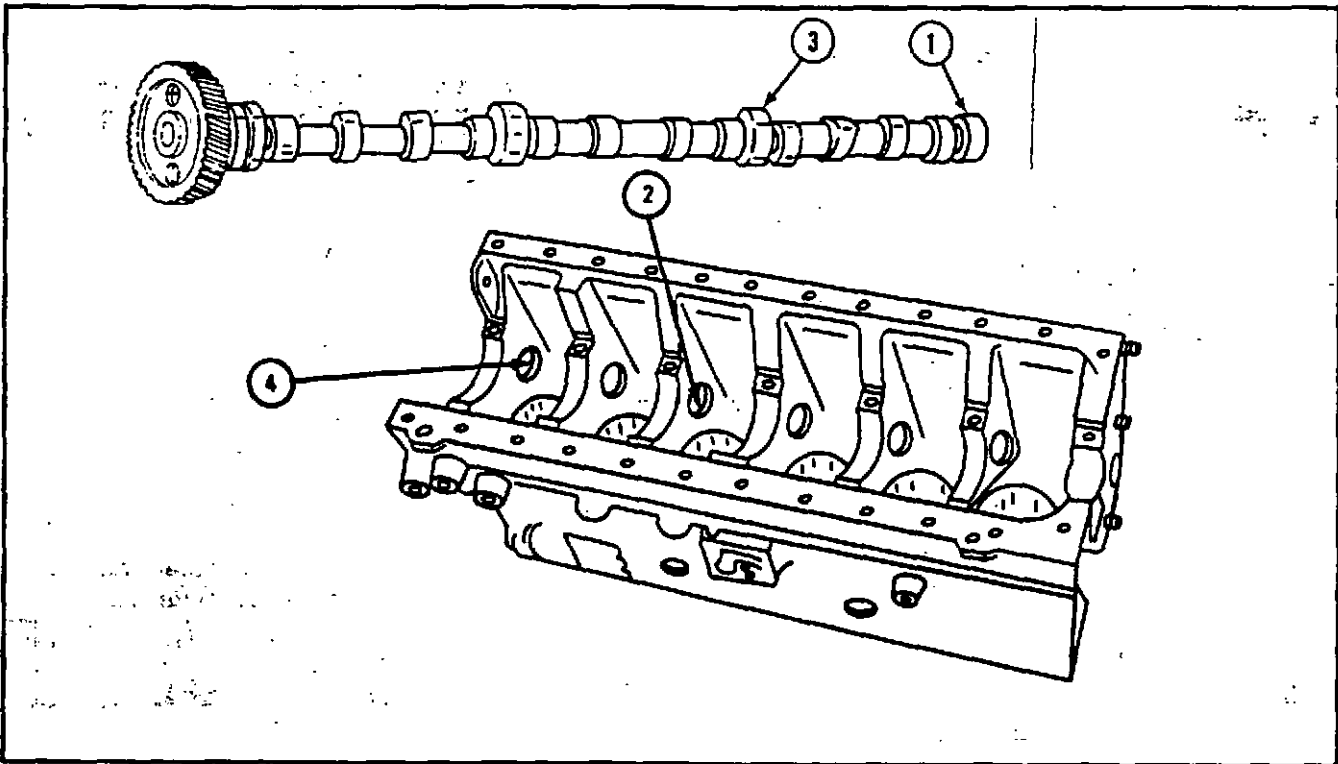

Front Camshaft Journals and Camshaft Bearings Wear Limits

Index Number	Item/Point of Measurement	Size and Fit of New Parts (inches)	Wear Limit (inches)
1 and 2	Fit of front intermediate camshaft journal in front intermediate camshaft bearing	0.0020 to 0.0040	0.0060 max
3 and 4	Fit of front camshaft journal in front camshaft bearing	0.0020 to 0.0040	0.0060 max

NOTE

There are two oil holes (1) in camshaft rear bearing bore (2). There are two oil holes (3) in rear camshaft bearing (4).

Oil holes (3) are a little bit closer to one end of rear camshaft bearing (4) than to other end. Rear camshaft bearing must be put in rear crankcase web (5) so that end of rear camshaft bearing with oil holes closest to it faces front of crankcase, as shown.

1. Mark rear crankcase web (5) with chalk or grease pencil next to oil holes (1) in camshaft rear bearing bore (2).

CAUTION

Both oil holes (1) in camshaft rear bearing bore (2) must line up with both oil holes (3) in rear camshaft bearing (4). Alinement of oil holes need not be perfect, but more than half the area of oil holes (3) must line up with oil holes (1). If this is not done, oil flow will be blocked and engine will be damaged.

2. Using camshaft bushing remover and replacer kit, put in new rear camshaft bearing (4). Use chalk mark on crankcase web (5) to help line up oil holes (3) with oil holes (1).

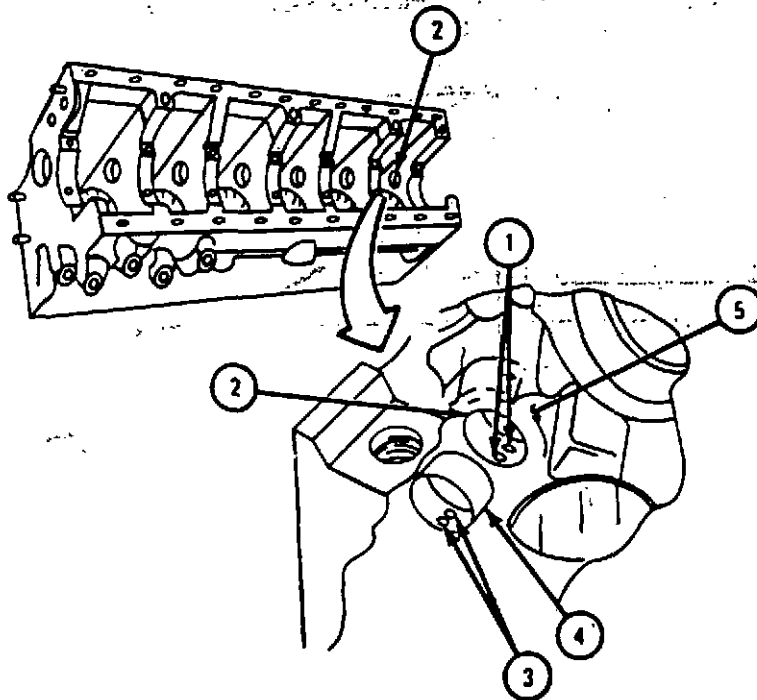

18. Install the fuel line.
19. Install and connect the air cleaner and connect the exhaust pipe to the manifold.
20. Connect the radiator hoses and fill the radiator with clean water or anti-freeze.
21. Install the oil pan, using new gaskets, and fill the crankcase with the proper grade of lubricating oil.

CONNECTING ROD BEARING REPLACEMENT.

If excessive clearance develops between the shaft and bearing shells, new bearing shells should be installed. If the clearance is excessive with the new bearings, regrind the shaft and use undersized bearings. Undersized bearings are available in sizes of .010 and .020.

The connecting rod bearings may be replaced as outlined below:

1. Remove the oil pan. See "Oil Pan, Oil Pump & Oil Pump Lines".
2. Locate the crankshaft so the connecting rod cap can be removed.
3. Remove the screws.
4. With a soft hammer, tap the cap to loosen it and remove the cap.
5. Replace the bearing shells as outlined under paragraph No. 8 and No. 9 (Connecting Rod Installing).
6. Reassemble the oil pan, oil pump and lines to the engine. See "Oil Pan".

COOLING SYSTEM.

Perhaps the best method for care of the cooling system is to clean and flush the system periodically; also, use some good rust and corrosion preventive between cleaning periods. Almost all natural water contains some mineral salts which stimulate corrosion.

Air leaks around the hose connections and through the water pump should be carefully guarded against. Check the hose connections frequently for leaks.

If the engine or unit is equipped with a pressure type sealed system, it is imperative that the correct type of radiator cap be used. This is determined by the type of system used.

There are two types of sealed cooling systems which are used extensively. One type has a safety relief valve arrangement built into the radiator filler cap, Illustration No. 12. The overflow pipe is also connected to the radiator filler neck above the lower seat of the pressure cap. In this manner, if excessive pressure develops in the cooling system, the lower part of the pressure cap will raise from its seat and allow the vapor to escape through the overflow pipe.

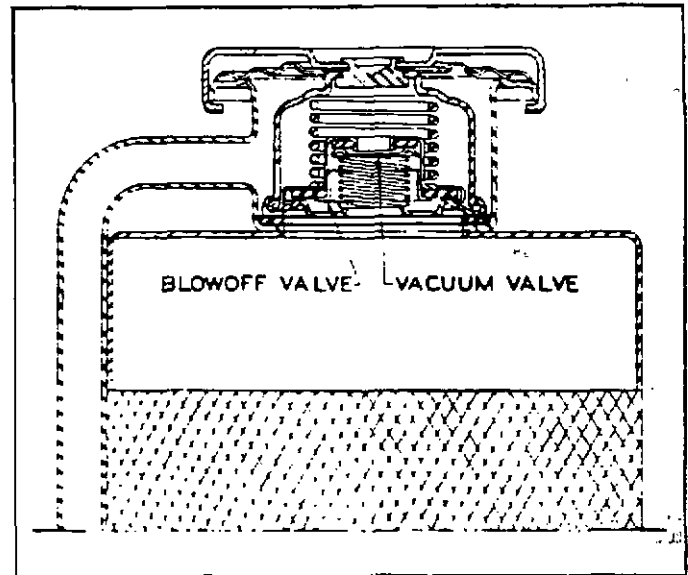

Illustration No. 12

This type of cap should never be removed quickly. Always turn the cap off slowly until the pressure has escaped through the overflow pipe, then remove the cap.

The second type of pressure sealed cooling system has the pressure relief valve and overflow pipe built into the top tank as a separate unit (not connected to the filler neck).

However, if any type of sealed cooling system is used, the proper filler cap, good gaskets and a smooth gasket surface are essential if excessive loss of the coolant is to be prevented.

From the above, it can be readily understood why serious overheating of the engine may result from loss of coolant or cooling efficiency when the incorrect filler cap, bad gaskets, or a rough gasket surface is encountered.

Use a good commercial neutralizer in the cooling system. To obtain the best results, follow the instructions of the manufacturer.

CRANKSHAFT

The crankshaft is a machined forging having all bearing journals surface-hardened. The nominal diameter of the main bearings is 3 41/64" while the nominal diameter of the connecting rod journals is 3". The shaft has passages drilled to carry oil, under pressure, to the connecting rod bearings. These passages should be cleaned with a wire brush, see Illustration no. before the shaft is installed in the engine.

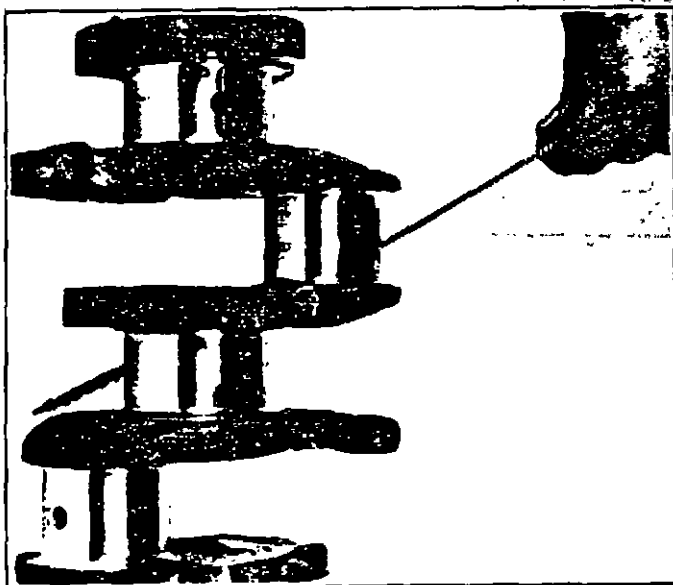

Illustration No. 13

The diameters given above are only nominal, see "Fits and Tolerances" for the actual standard sizes.

WARNING: When regrinding a crankshaft, it is imperative that the original 5/32" radius from journal to cheek be maintained. Crankshaft breakage may result from improper grinding of this fillet. The shafts are available in .010, and .020 undersize only.

For installation of pilot bushing in crankshaft, see Illustration No. For method of indicating bushing, see Illustration No.

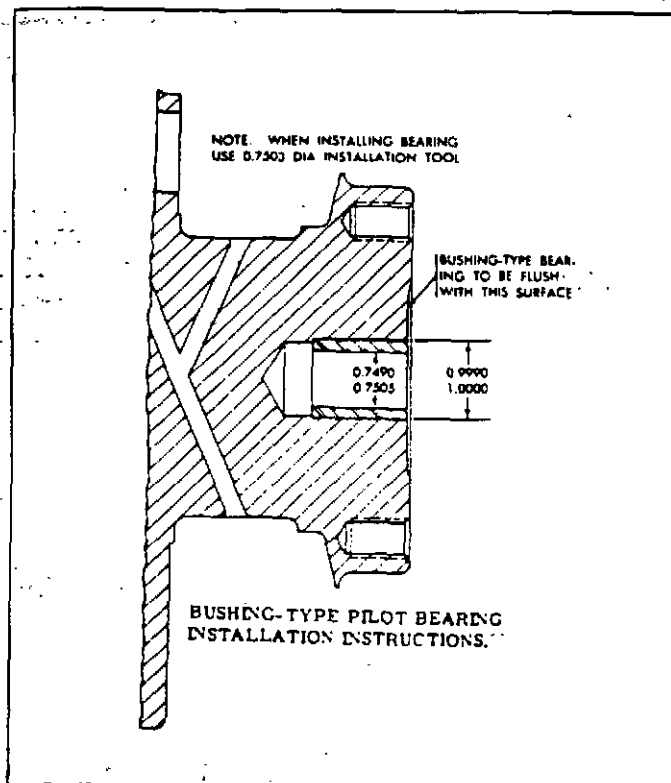

Illustration No. 14

TO REMOVE THE CRANKSHAFT GEAR

If a suitable arbor press is not available, the following method may be used. This gear is a snug fit on the crankshaft, and it is possible to pull this gear with any of the commercial pullers. Since replacement of this gear would only be brought about by the gear being badly worn or damaged, making replace-

ment necessary, it will be necessary to replace all gears at the same time.

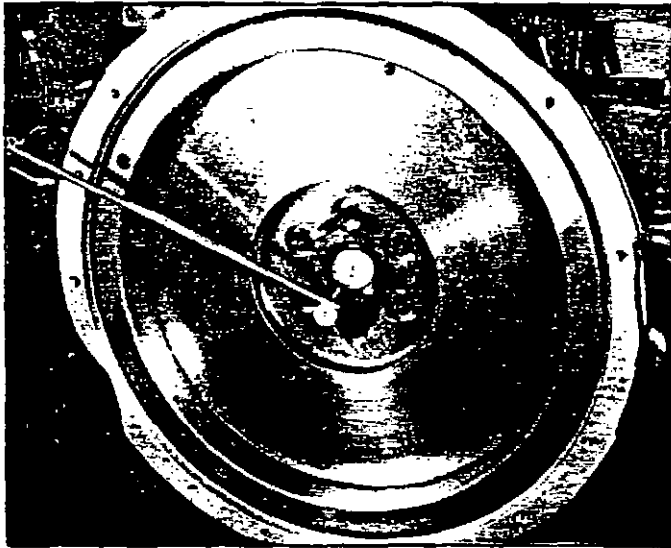

Illustration No. 15

CRANKSHAFT GEAR, AND CAMSHAFT GEAR.

a. Removal. Remove crankshaft gear and camshaft gear.

Align timing marks on crankshaft and camshaft gears. Remove crankshaft gear.

b. Inspection and Installation: Inspect and install crankshaft gear, and camshaft gear.

1. Check condition of gear keyways. Key must be in proper condition, not worn, and must fit tight in keyway. Check thrust surface of camshaft.

CRANKSHAFT DAMPER AND PULLEY ASSEMBLY.

a. General: The crankshaft damper and pulley assembly must be removed from the crankshaft in order to replace the pulley and/or damper.

b. Removal: Remove crankshaft damper and pulley assembly as follows:

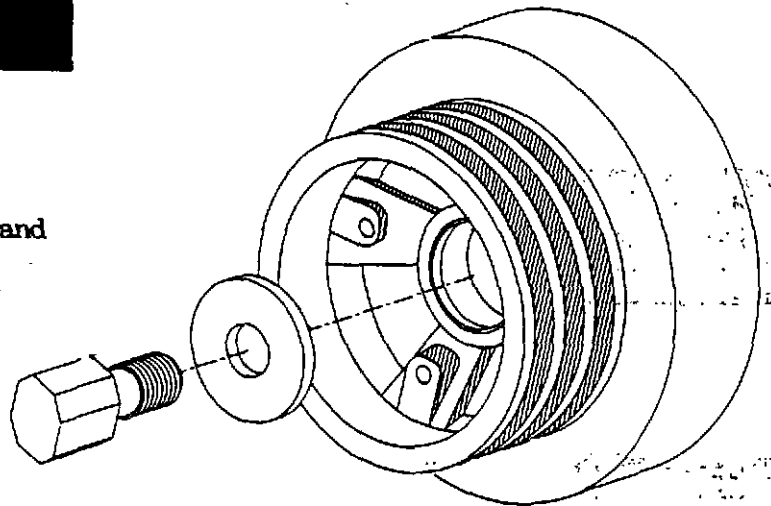

Illustration No. 17

1. Remove engine fan from water pump pulley.

2. Remove drive belts.

3. Remove crankshaft damper pulley retaining bolt. See Illustration No.

4. Install mechanical puller on hub of pulley. Puller holes are in pulley for this purpose.

6. A viscous damper which has no rubber is used and should be inspected regularly and replace if dented.

C. Inspection and Repair:

1. Inspect oil seal contact surface for nicks or burrs which may damage oil seal. Remove minor damage with Crocus cloth.

2. Check keyway for burrs or damage. Check damper and pulley for cracks.

D. Installation: Before installing crankshaft damper and pulley assembly on crankshaft, coat lip of crankshaft front oil seal and sealing surface on pulley with lubricating oil to prevent damage to oil seal lip when pulley is installed.

CRANKSHAFT FRONT OIL SEAL

A. Removal: Remove crankshaft front oil seal as follows:

1. Remove engine fan and all belts.
2. Remove water pump assembly.
3. Remove crankshaft damper and pulley assembly.
4. Remove oil pan front screws that hold pan to cover, loosen balance of capscrews so front of pan drops away from gear cover.
5. Remove tachometer adapter, drive shaft and mounting adapter.

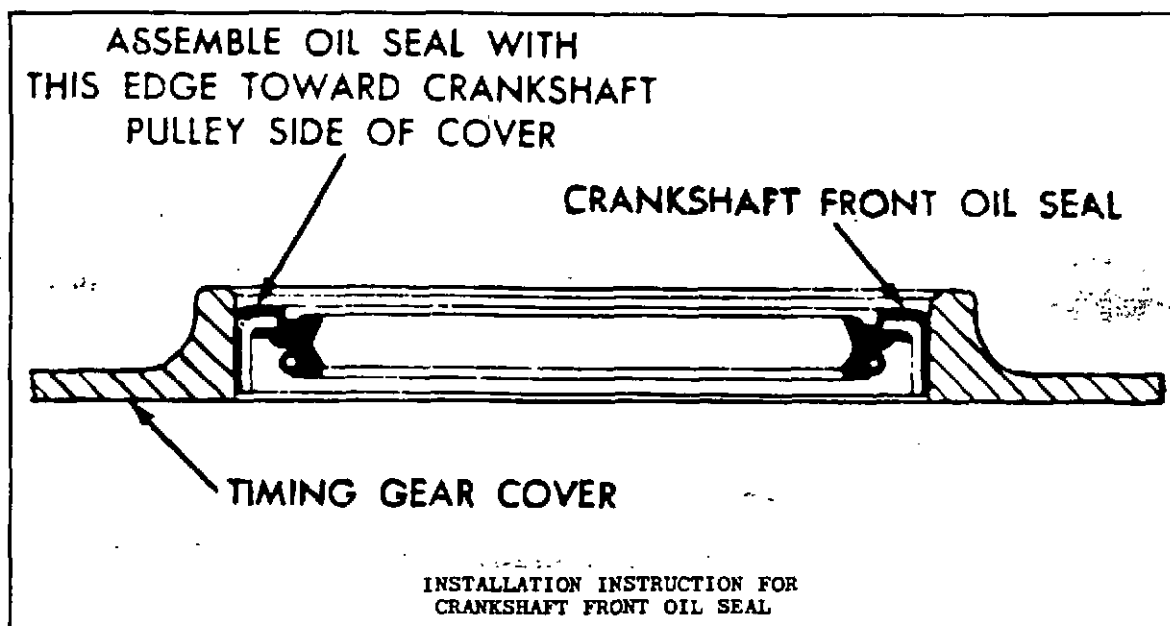

Illustration No.

6. Remove crankshaft front oil seal from timing gear cover assembly.

b. Installation: Install crankshaft front oil seal as follows: See Illustration No.

1. The crankshaft front oil seal has a double lip which must be installed in the timing gear cover assembly with flange edge away from cover mounting flange.

2. Position crankshaft front oil seal in bore of timing gear cover assembly. Install seal in bore using arbor press and suitable press plate.

3. The timing gear cover assembly is positioned on two locating dowel pins. When installing cover, cover must be properly positioned on pins before tightening capscrews.

CYLINDER AND CRANKCASE

The cylinders are cast integral with the crankcase and have the water jacket carried the full length of the cylinders. This results in uniform cooling of the piston and cylinder wall.

Material is cast iron with forged bearing caps fastened to the cylinder block

with 9/16 capscrews. The most casual inspection of the cylinder block will disclose the very rigid construction provided to support the crankshaft and this rigidity, coupled with the large diameter of the crankshaft, results in a very rugged and smooth running engine. See Illustration No.

All engines are equipped with dry, removable cylinder sleeves. See "Cylinder Sleeve".

The cylinder block has a drilled passageway running the length of the block, known as an oil header, which is closed on the ends with suitable pipe plugs. From this header, various passages are drilled to carry oil to the main bearings, camshaft bearings and rocker arms. See Illustration No.

All oil passages should be thoroughly cleaned with a wire brush and solvent at overhaul time.

To replace the main bearings, see "Main Bearings".

Core openings are closed by expansion type steel plugs. If any of these should leak, remove and replace with new plugs.

CYLINDER HEAD

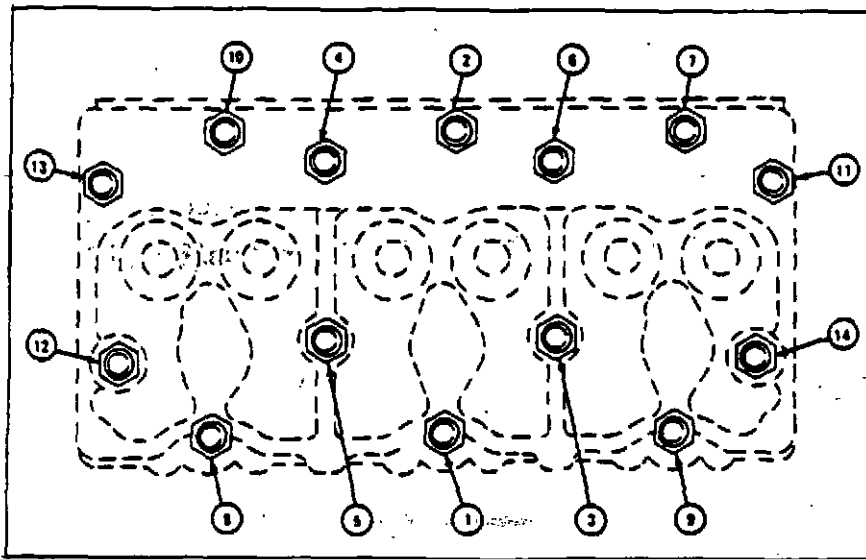

Illustration No. 20

The cylinder heads are one piece castings and are interchangeable. The valve seats and the valve guides are removable. The head is held to the cylinder block by studs; and, in order to insure against leaks, the head must be carefully drawn down by means of the stud nuts which should be progressively tightened, working from the center of the head toward the ends, as shown in Illustration No. 20 which shows torque of nuts and sequence for tightening.

Step 1 - Tighten to 110 ft. lbs.

Step 2 - Tighten to 130 ft. lbs.

Step 3 - Tighten to 157 ft. lbs.

Step 4 - After approx. 15 minutes, Re-torque to 157 ft. lbs.

NOTE: Do not use any sealants, aluminum paint, etc., on this gasket. Do not retorque hot. If any seepage occurs, retorque cold only.

TO REMOVE THE CYLINDER HEAD

1. Drain the radiator and remove the water thermostat housing and hoses and water manifolds. Also, disconnect the water temperature gauge thermocouple.
2. Disconnect the exhaust pipe.
3. Disconnect the air cleaner or pipe from the turbocharger and remove.
4. Shut off gas supply line to engine. Disconnect gas supply line at engine.
5. Remove the cylinder head covers, rocker arm assemblies and push rods. Remove turbo exhaust manifold and intake manifold.
6. Remove the cylinder head nuts and lift the cylinder heads from the engine. Tap the heads lightly with a soft hammer, if necessary, to loosen it. Do not pry on the contact surfaces.

By leaving intake and exhaust manifolds on heads and using a spreader bar, both heads can be removed together.

CYLINDER HEAD INSPECTION.

Cylinder head assembly: Check cylinder head assembly for cracks especially near fillets and around studs and pipe plug openings. Check gasket surfaces for burrs or nicks. Replace cracked cylinder head.

Pressure test coolant passages of cylinder head at 40 PSI air immersed in 120°F water, minimum time - 5 minutes. Reject all cylinder heads with evidence of leakage.

IMPORTANT

Bridge cracks shall not be cause for rejection except when the crack extends below the valve seat insert and/or insert counterbore.

Check the cylinder head for straightness. The maximum permissible out of flat when checking lengthwise is 0.005 inch. The maximum out of flat when checking crosswise is 0.003 inch. Inspect studs for bent condition or damaged threads.

REPAIR

a. CYLINDER HEAD: Replace studs that are stripped or broken, replace complete cylinder head assembly when cracked, warped, or beyond repairs.

1. CYLINDER HEAD REFACING: When a cylinder head is warped beyond the maximum permissible clearance, the cylinder head can be refaced using a surface grinder. When cylinder head is refaced, grind valve seats as directed in paragraph on valves. Replace the cylinder head when excessive grinding is required to recondition gasket surface.

TO REPLACE THE CYLINDER HEAD.

1. Before installing the cylinder heads, clean out the carbon deposits by scraping or brushing. If the valves are to be ground or otherwise serviced, see "Valves".

2. Clean the cylinder block and cylinder head contact surfaces.

3. Install new cylinder head gaskets.

4. Place cylinder heads and valve assembly on the block.

5. Start the head nuts and tighten evenly, using a torque wrench. Start at the center of the head and work progressively to the outer ends, see Illustration No. and "Fits and Tolerances".

6. Install the push rods and rocker arms. Install manifolds, and turbocharger.

7. Adjust the valve tappets to the proper clearance. See "Valves".

8. Install the cylinder head cover, using a new gasket, if required.

9. Connect the gas line.

10. Inspect the thermostat. See "Thermostat", Illustration No.

11. Install the thermostat, housing, hoses, and water manifold. Connect the water temperature gauge thermocouple.

12. Install the air cleaner hose, using new gaskets, if required.

13. Connect the exhaust pipe, using new gaskets.

14. Fill the cooling system with the proper solution (water and antifreeze.)

CYLINDER SLEEVES

The cylinder sleeves are dry removable type, precision machined to size, and are a slip fit. A puller may be required to remove the sleeves, and dressing of the cylinder bore may be necessary before installing.

No more than a total of 0.005 inch can be machined off gasket surface of cylinder head (1). If cylinder head has been resurfaced before, amount of metal machined off is stamped or etched on front of cylinder head about 1/2 inch from gasket surface.

resurface cylinder head (1) until no scratch or gouge is deeper than 0.001 inch. Resurface cylinder head until it is not out-of-flat lengthwise by more than 0.005 inch or out-of-flat crosswise by more than 0.003 inch.

Measure thickness of cylinder head (1) from gasket surface to bottom of valve spring counterbores (2). If thickness is less than 3.365 inches, get a new cylinder head.

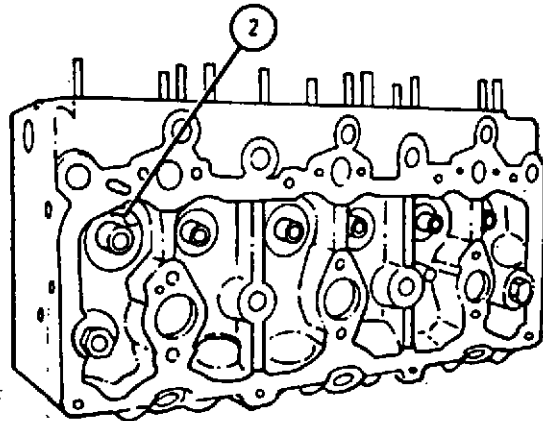
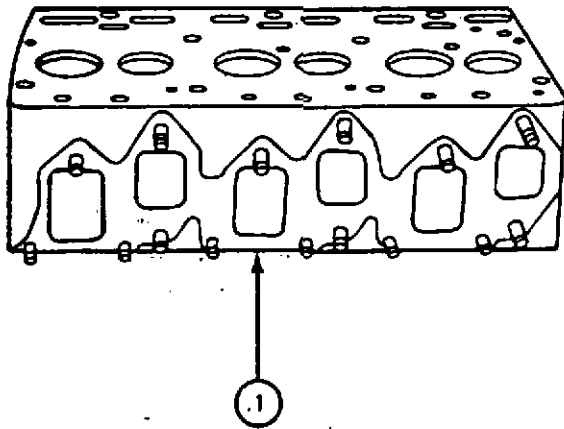

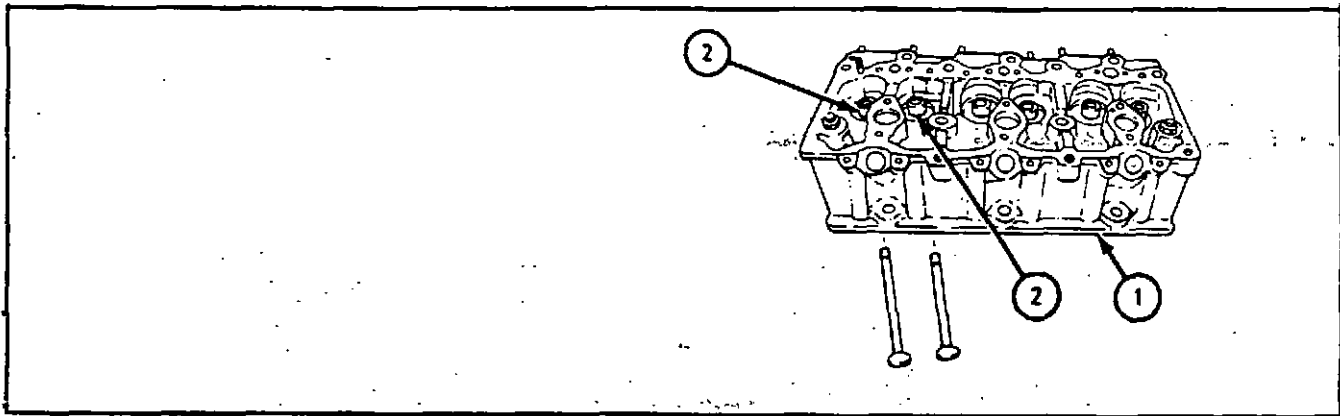

Valve Guides and Valve Guide Bores Wear Limits

Index Number	Item/Point of Measurement	Size and Fit of New Parts (inches)	Wear Limit (inches)
1	Valve guide bore in cylinder head inside diameter	0.6865 to 0.6875	None
2	Valve guide outside diameter	0.6880 to 0.6885	None
1 and 2	Fit of valve guides in cylinder head bores	0.0005T to 0.0020T	None

T = TIGHT FIT

Exhaust Valve Seat Inserts and Counterbores Wear Limits

Index Number	Item/Point of Measurement	Size and Fit of New Parts (inches)	Wear Limit (inches)
3	Exhaust valve seat counterbores inside diameter Standard size	1.8080 to 1.8090	1.8095
1	Exhaust valve seat insert outside diameter Standard size DEPTH OF VALVE SEAT INSERT	1.8120 to 1.8130 0.3825 to 0.3875	None
3 and 1	Fit of exhaust valve seat insert in counterbore	0.0030T to 0.0050T	0.0025T

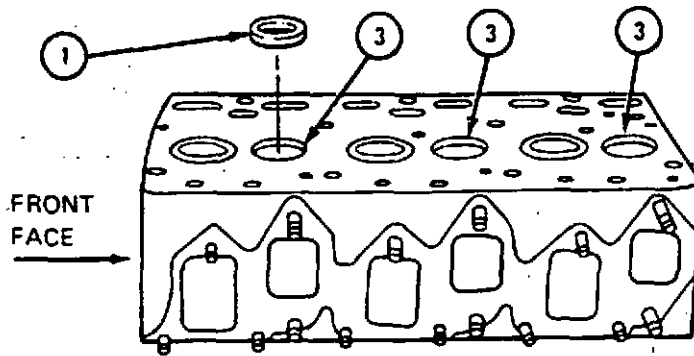

Intake Valve Seat Inserts and Counterbores Wear Limits

Index Number	Item/Point of Measurement	Size and Fit of New Parts (inches)	Wear Limit (inches)
3	Intake valve seat counterbore inside diameter	2.0580 TO 2.0590	2.0595
1	Intake valve seat insert outside diameter	2.0615 to 2.0625	None
3 and 1	Fit of intake valve seat insert in counterbore DEPTH OF VALVE SEAT INSERT	0.0025T to 0.0045T 0.4155 TO 0.4205	0.0020

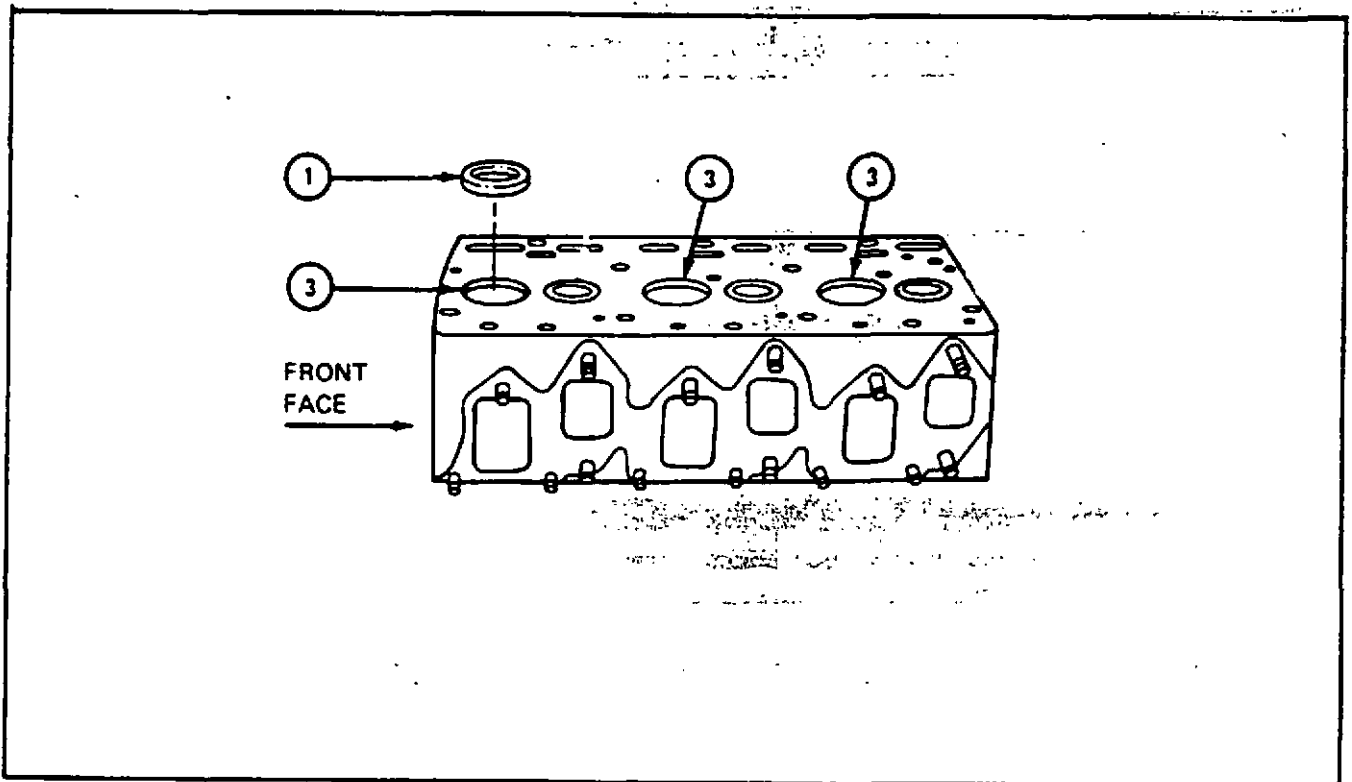

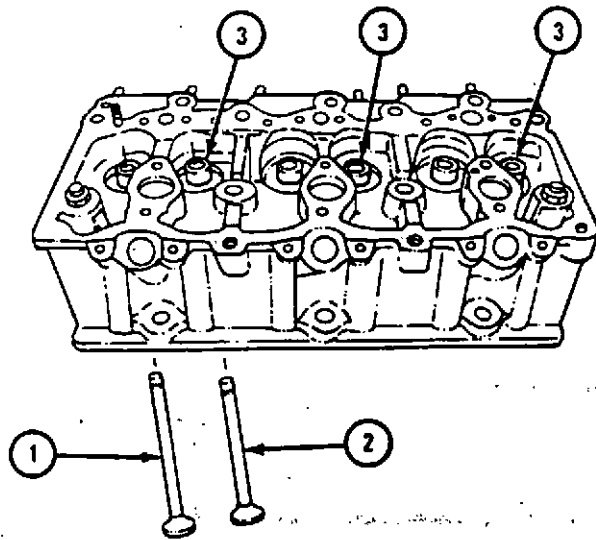

Exhaust Valves and Guides Wear Limits

Index Number	Item/Point of Measurement	Size and Fit of New Parts (inches)	Wear Limit (inches)
2	Exhaust valve stem outside diameter	0.4363 to 0.4368	0.4358
3	Exhaust valve guide inside diameter	0.4388 to 0.4394	0.4420
2 and 3	Fit of exhaust valve stem in exhaust valve guide	0.0020L to 0.0031L	0.0070L

Intake and Exhaust Valve Length Wear Limits

Index Number	Item/Point of Measurement	Size and Fit of New Parts (inches)	Wear Limit (inches)
1	Intake valve length from tip to gage line	6.0820 to 6.0880	6.0980
2	Exhaust valve length from tip to gage line	6.0700 to 6.0760	6.0860

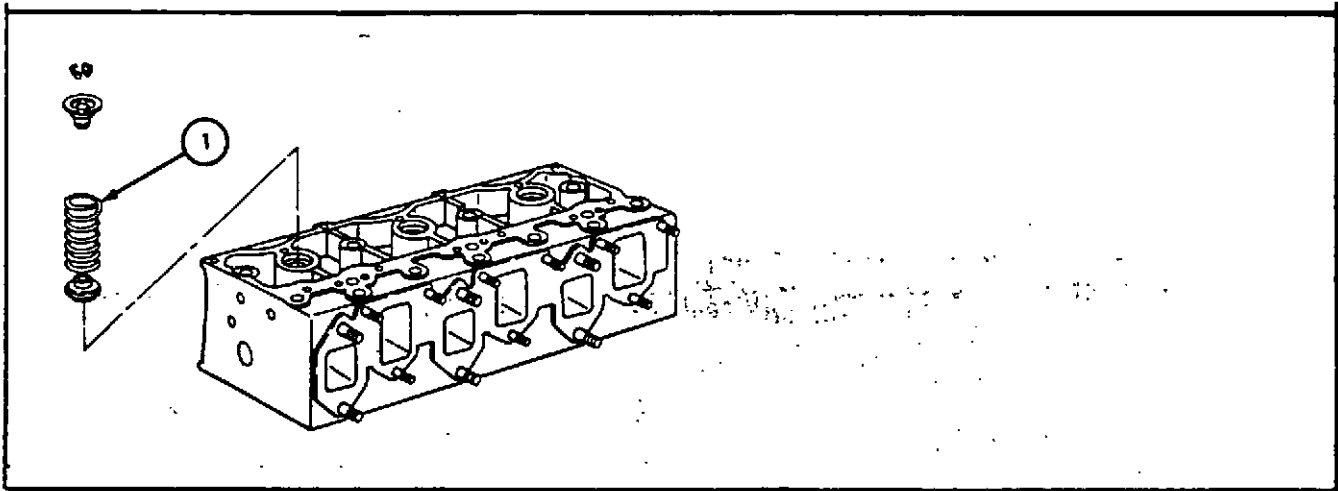

Valve Spring Wear Limits

Index Number	Item/Point of Measurement	Size and Fit of New Parts (inches unless otherwise noted)	Wear Limits (inches unless otherwise noted)
1	Outer valve spring free length	2.5100 to 2.7100	None
1	Outer valve spring load at 1.67 inches	153.7 to 167.7 pounds	147 pounds
1	Outer valve spring load at 2.12 inches	62.7 to 68.7 pounds	63 pounds

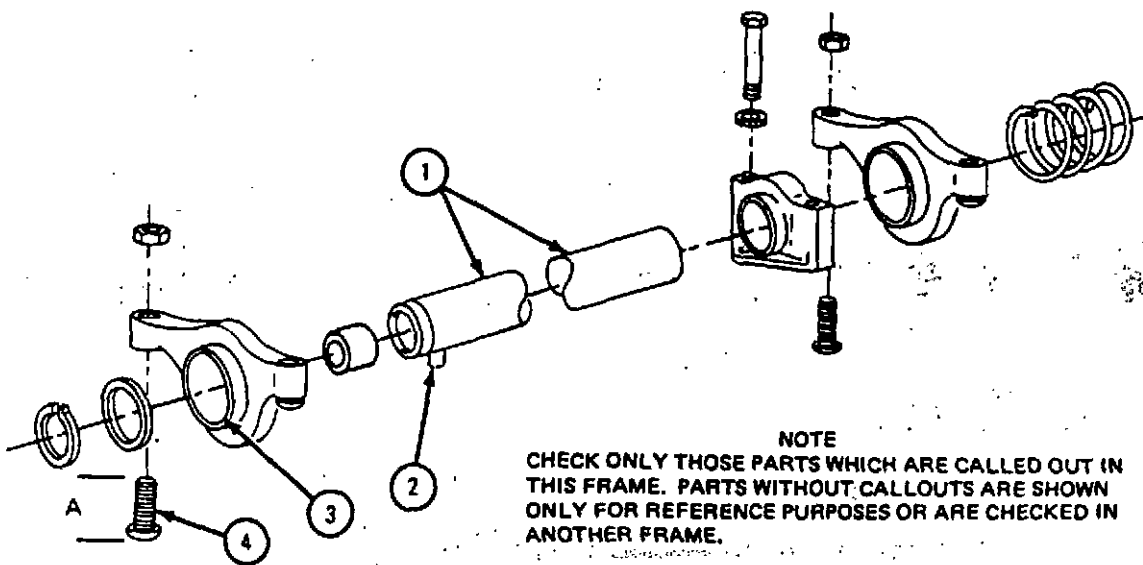

Valve Rocker Arm Bearings and Shafts Wear Limits

Index Number	Item/Point of Measurement	Size and Fit of New Parts (inches)	Wear Limit (inches)
3	Rocker arm bearing inside diameter	1.0025 to 1.0038	1.0070
1	Rocker arm shaft diameter at rocker arm bearing surface	0.9998 to 1.0005	0.9988
3 and 1	Fit of rocker arm bearing on shaft	0.0020L to 0.0040L	0.0090L
4	Valve adjusting screw length A	1.740	None

Valve Rocker Arm Thrust Spring Wear Limits

Index Number	Item/Point of Measurement	Size and Fit of New Parts (inches unless otherwise noted)	Wear Limit (inches)
5	Thrust spring free length	3.500	None
5	Thrust spring load at 2 inches	8.8 to 9.0 pounds	7 pounds
5	Thrust spring maximum solid height	0.7300	None

FAN ASSEMBLY (Cooling)

The cooling fan is mounted on the water pump driven pulley, which is driven from a drive pulley mounted on the crankshaft by the use of one or more "Vee" belts. Various accessories may be mounted on the engine and driven by these belts. Therefore, it is not possible to list the fan belt specifications.

FLYWHEEL

Flywheels used on this series of engines are made of cast iron and may be machined to accommodate different types and sizes of clutches, and other types of couplings. The flywheel is fastened to the crankshaft with six bolts. One of these bolts is off center so that the flywheel can only be installed in one position. This properly locates the flywheel on the crankshaft.

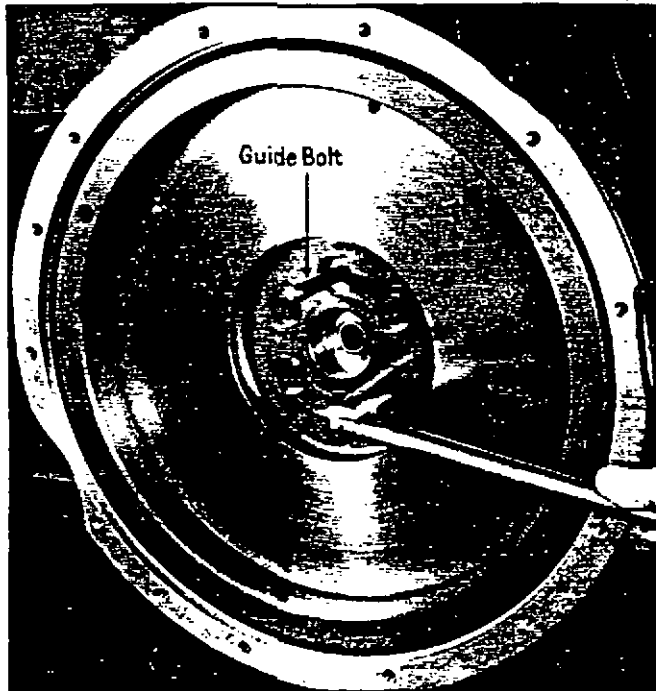

Illustration No. 21

TO REMOVE THE FLYWHEEL.

1. Disconnect and remove the transmission and clutch or torque converter.
2. To assist in the removal of the flywheel, fabricate a 1/2" x 20" x 4" long

guide bolt by cutting off the head. See Illustration No. 21.

Remove one flywheel bolt and install this guide bolt in its place. Then when balance of bolts are removed, there will be a pilot for sliding flywheel on bolt to assist in removal from housing.

3. Using a Lady-Foot pry bar, if necessary, to pull the flywheel from the crankshaft.

TO INSTALL THE FLYWHEEL AND INDICATE.

1. Reverse instructions under heading "To Remove the Flywheel" above.
2. Use a dial indicator to check the concentricity of the pilot bore. This should not exceed .005 total reading. See Illustration No.
3. Attach the dial indicator, as shown in Illustration No. to check the face of the flywheel. This should not exceed .008 total reading.
4. Install the starting motor.
5. Install the clutch and transmission as removed.

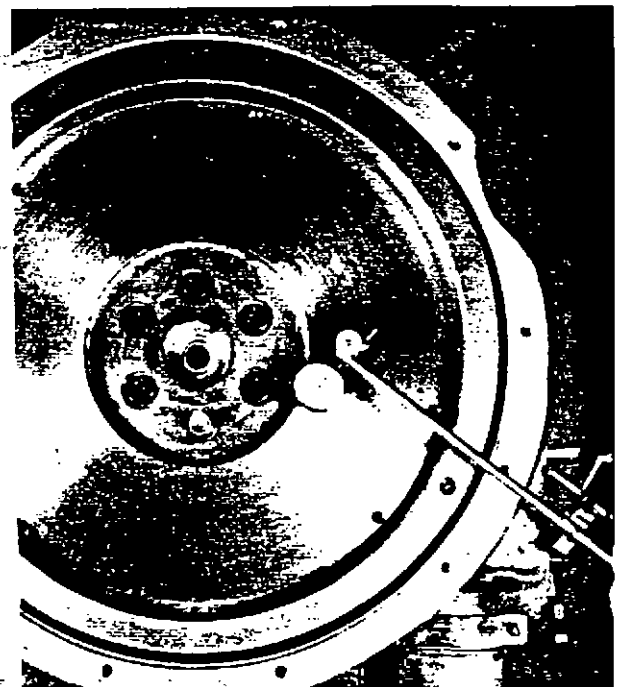
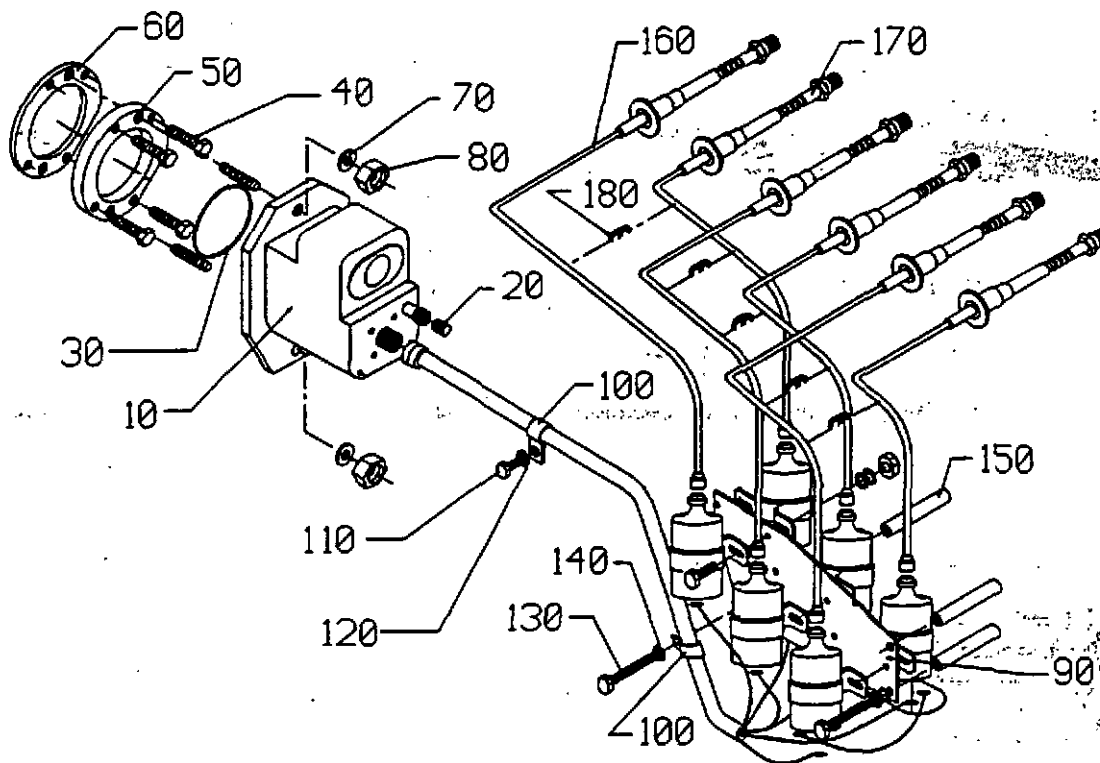

Illustration No. 22

G-4800-TA IGNITION SYSTEM



No.	QTY	COMPONENT
10	1	Altronic and Gear, Assembly
20	1	Shorting plug
30	1	O-Ring
40	4	Bolt - 5/16-18 x 7/8
50	1	Adapter Assembly
60	1	Gasket
70	2	Washer, altronic to adapter
80	2	Nut, altronic to adapter
90	1	Coils and mtg. bracket, Assembly
100	2	Clamp - cable
110	1	Bolt - 3/8-16 x 3/4
120	1	Lockwasher - 3/8
130	3	Bolt - 3/8-16 x 4 1/2"
140	3	Washer
150	3	Spacer
160	1	Cable Assembly, spark plug
170	6	Spark Plug
180	8	Clip - wire support

GTA-4800 FRONT COVER AND PLATE

GEAR HOUSING

The gear housing plate forms the front support for the engine and is doweled to the cylinder block. The gear housing covers the gears. The front oil seal for the crankshaft is also installed in the housing. This housing may be removed for the inspection of the gears, and so forth.

TO REMOVE THE GEAR HOUSING.

Assuming that the radiator has been removed, the gear housing may be removed as follows:

1. Remove the fan blade and belt for easier access to the gear housing and gears.
2. Remove the crank nut and fan drive pulley and vibration damper.
3. Remove the screws from the gear housing and pull the gear housing forward away from the engine.

4. If necessary to remove the gear housing plate, remove the camshaft gear as outlined under "Camshaft", remove the attaching screws and pull the plate forward away from the cylinder block. It may be necessary to tap the plate with a soft hammer to loosen it from the dowels or gasket cement.

INSPECTION.

The gear housing should be carefully inspected for possible cracks, binding, etc.

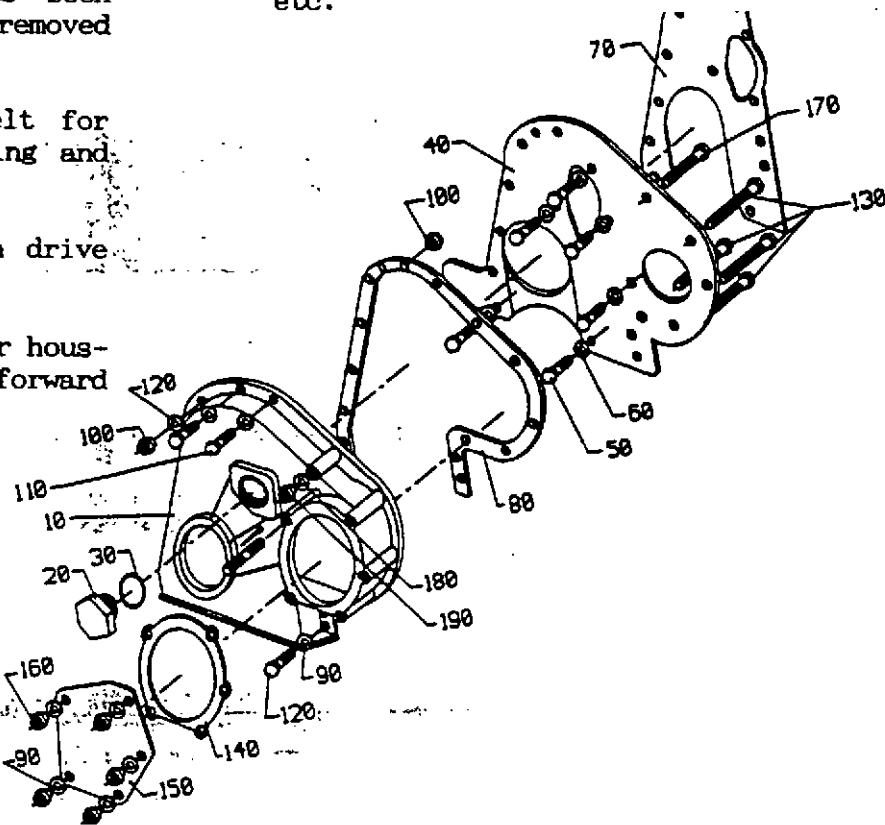

No.	QTY	COMPONENT
10	1	Front Cover, Assembly
20	1	Plug, tach opening
30	1	Gasket, plug att
40	1	Front Plate
50	6	Bot, frt plate to block - 3/8-16 x 1"
60	6	Lockwasher, frt plate to block - 3/8"
70	1	Gasket, plate to block
80	1	Gasket, frt cover to plate
90	13	Lockwasher, frt cov/gov cov att - 3/8
100	2	Nut, frt cover to frt plate - 3/8-16
110	1	Bolt, frt cover to frt plate - 3/8-16 x 1 1/4
120	6	Bolt, frt cover to block - 3/8-16 x 1 3/8"
130	4	Bolt, frt plate to front cov to gov cov - 3/8-16 x 3 3/4"
140	1	Gasket, governor cover att
150	1	Cover, governor access
160	5	Nut, frt plate to frt cov to gov cov - 3/8-16
170	1	Bolt, frt cov to frt plate - 1/2-13 x 2 3/4"
180	1	Lockwasher, frt cov to frt plate - 1/2"
190	1	Nut, frt cov to frt plate - 1/2-13

Tightening of the main bearing cap screws requires some care to prevent too much strain on the parts. Torque wrenches are on the market which enable the mechanic to measure the force of his pull when tightening such parts. The wrench tension values given under "Fits and Tolerances", show the correct amount of torque to use. No attempt should be made to refit these bearings by filing or grinding the caps, as this will ruin the caps so new shells cannot be installed. See Illustration No.

REPLACEMENT OF THE MAIN BEARINGS.

It is not necessary to remove the engine from the unit to replace the main bearings unless, of course, the crankshaft is damaged or worn to the extent that it must be replaced.

The following outline may be used as a guide for replacing the bearings when the engine has not been removed from the unit:

1. Disconnect the battery cable at the battery as a safety measure.
2. If the starter is mounted below the oil pan level and causes interference, disconnect the starter cable and wiring; then remove the starter.
3. Drain the crankcase oil.
4. Remove the oil pan.
5. Remove the oil pump.
6. Loosen all main bearing cap screws.

Remove one bearing cap at a time and make bearing replacement. To remove the upper shell, a cotter pin, shaped like Illustration No. , may be inserted in the crankshaft oil hole and the shaft rotated so that the pin will push the bearing out. The new bearing may be inserted in the same manner. See Illustration No.

CAUTION: Be sure to remove the pin before assembling the bearing cap.



Illustration No. 33

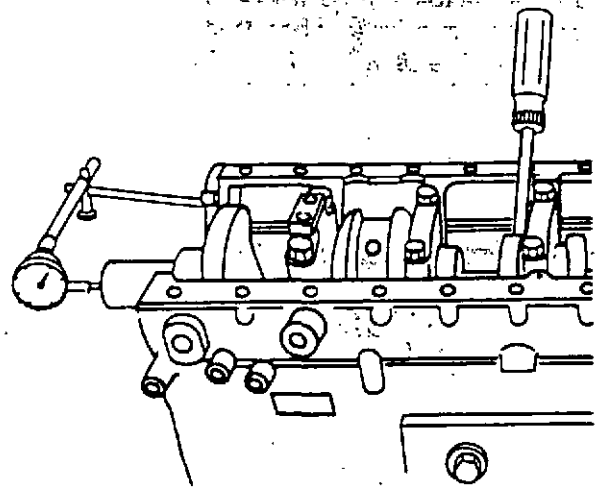

Illustration No. 34

9. Assemble the bearing cap and lower shell and tighten the screws. See "Wrench Tension".

10. After installing new thrust bearings on the center main bearing, check the end thrust, see Illustration No. . See "Fits and Tolerances". It is permissible to dress the thrust bearing to obtain the proper clearance, if necessary. This is done by rubbing thrust flanges on a piece of Crocus cloth on a flat surface until proper clearance is obtained.

11. Thoroughly recheck the inside of the engine for loose screws, nuts, etc.

12. Install the oil pan.

13. Install the starter.

14. Connect the starter cables.

15. Connect the battery cable.

16. Fill the crankcase to the FULL mark on the bayonet gauge, see Illustration No. with the proper grade of oil.

17. Start the engine and immediately check the oil pressure. See "Oil Pressure". If sufficient, allow the engine to run for a few minutes while checking for oil leaks, etc.. Then stop the engine and recheck the oil level. Add oil, if necessary.

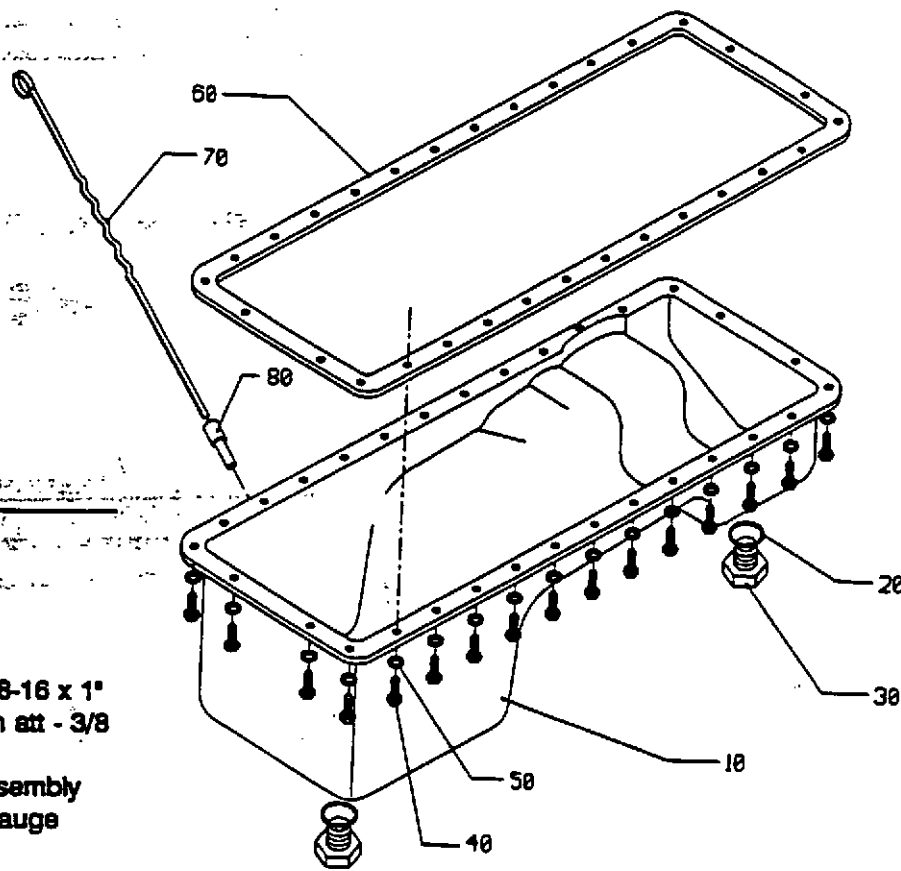

No.	QTY	COMPONENT
10	1	Oil Pan
20	2	Gasket, plug att
30	2	Plug
40	30	Bolt, oil pan att - 3/8-16 x 1"
50	30	Lockwasher, oil pan att - 3/8
60	1	Gasket, oil pan
70	1	Bayonet gauge, Assembly
80	1	Adapter, bayonet gauge

GTA-4800 EXHAUST MANIFOLD

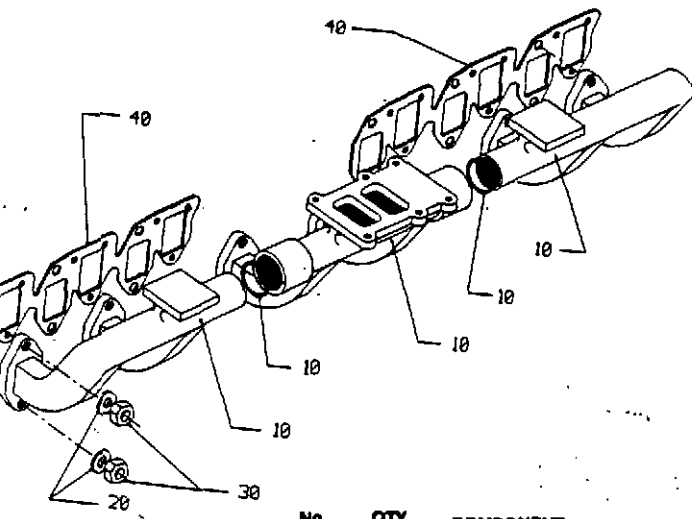

No.	QTY	COMPONENT
10	1	Exhaust Manifold, Assembly - 3 piece
20	12	Washer, manifold att - 7/16
30	12	Nut, manifold att - 7/16-14
40	2	Gasket, manifold att - graphite

MANIFOLDS (Intake and Exhaust)

There are various types of manifolds used; therefore, it is not practical to discuss them at length in this book. Manifolds differ as to the air cleaner attaching flanges and shape. Different exhaust outlet flanges are used on different installations. From this list of differences, one can readily see the importance of replacing the manifold on the engine with the same type manifold unless the engine is to be applied to a different type of operation.

In installing the manifolds, it is essential to use new gaskets and to be sure that the manifold ports line up with those in the cylinder head. When tightening the manifold studs nuts, a washer should be used under the nut and the manifolds tightened progressively from the center to the end, repeating the operation at least three or four times to make sure that the manifold is tight.

In many instances, a companion flange and gasket are used for the installation of the exhaust pipe. Be sure these are drawn up tight and square with the manifold flange to avoid leaks.

TO REMOVE THE MANIFOLDS.

1. Remove the air cleaner or air cleaner connections from the intake manifold.
2. Disconnect the exhaust pipe from the turbocharger.
3. Remove the manifold attaching nuts and washers and remove the manifold. Both manifolds have to be removed together.

TO INSTALL THE MANIFOLDS.

1. Make sure all gasket surfaces are clean, place the manifold gaskets on the attaching studs and assemble both manifolds to the engine with the nuts and washers as removed.
2. Tighten the manifold into place. Tighten all nuts lightly; then, starting from the center, work progressively toward the ends of the manifolds repeating until all nuts are tight.
3. Attach the exhaust pipe and tighten the screws.
4. Install the air cleaner or connect the air inlet tube to the intake manifold.
5. After the engine has been operated a day or more, tighten all manifold attaching nuts.

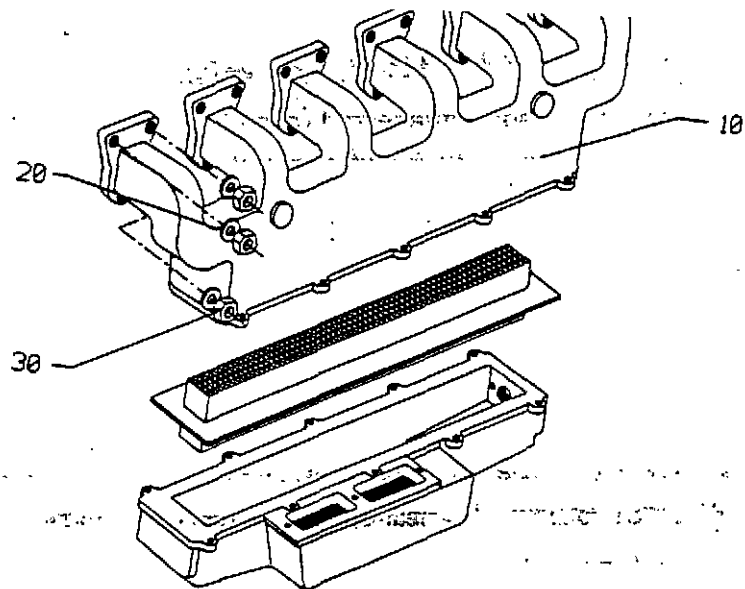

No.	QTY	COMPONENT
10	1	Intake Manifold & Flame Arrestor, Assembly
20	18	Washer, manifold att - 5/16"
30	18	Nut, manifold att - 5/16-24

OIL FILTER

The lubrication system is designed with a full-flow type oil filter and oil cooler.

Filters should receive regular and careful attention. A definite schedule for replacement of the element can be determined from observation of the lubrication oil on the application in which the engine is used. In some applications, the period between changing the filter element may be very short while in others the change period may be extended considerably. Cold engine operation and long idling periods contribute to short

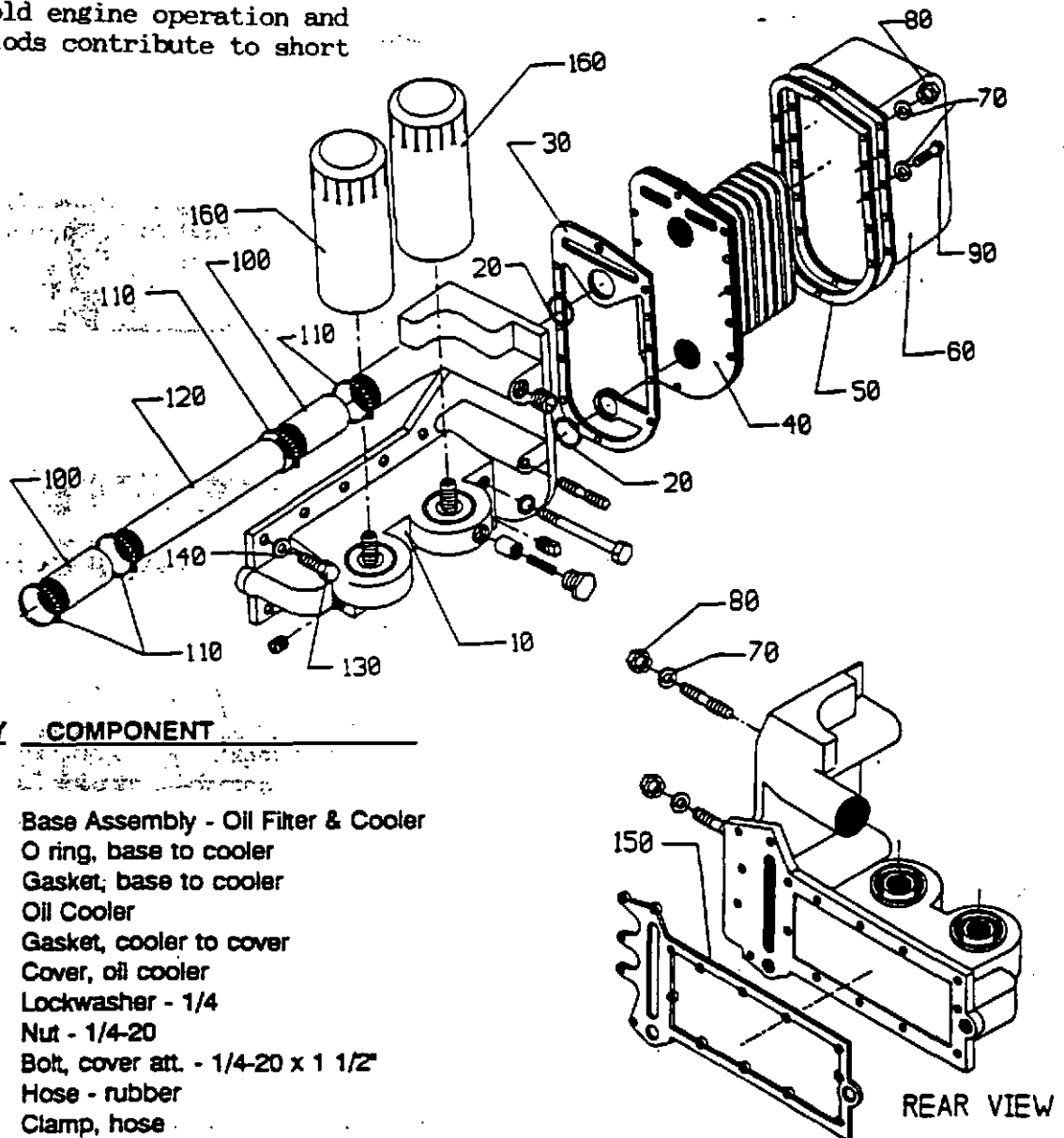

No.	QTY	COMPONENT
10	1	Base Assembly - Oil Filter & Cooler
20	2	O ring, base to cooler
30	1	Gasket, base to cooler
40	1	Oil Cooler
50	1	Gasket, cooler to cover
60	1	Cover, oil cooler
70	12	Lockwasher - 1/4
80	2	Nut - 1/4-20
90	10	Bolt, cover att. - 1/4-20 x 1 1/2"
100	2	Hose - rubber
110	4	Clamp, hose
120	1	Inlet tube
130	16	Bolt, base to block - 3/8-16 x 7/8"
140	16	Washer, base to block - 3/8
150	1	Gasket, base to block
160	2	Oil Filter

REAR VIEW

filter element life. See "Preventive Maintenance Schedule".

When new filter elements are installed, add sufficient oil to the crankcase so the oil level will be correct after the engine has run long enough to refill the filters. For filter location, see Illustration in front of book.

OIL PAN

The oil pan serves as a cover for the bottom of the crankcase and also as an oil reservoir.

Suitable drain plugs are located in the bottom of the oil pan, one in each sump. The bayonet type oil gauge, used to measure the oil level in the pan, is covered under "Bayonet Gauge".

TO REMOVE THE OIL PAN.

1. Drain the crankcase oil from both sumps.
2. Disconnect the starter cable and remove the starter, if mounted below the center line. Tape any "hot" cable terminals.
3. Remove the bayonet gauge assembly.
4. Remove the cap screws from the oil pan and remove the oil pan from the engine.

TO INSTALL THE OIL PAN.

1. Clean the oil pan thoroughly; also, remove the old gaskets from the oil pan and cylinder block.
2. Inspect the inside of the engine for loose nuts, screws, cotter pins, lock wires, etc.; tighten or replace.
3. Cement the new oil pan gasket to the oil pan.
4. Draw up all screws evenly and progressively.
5. Install the drain plugs.

6. Install the starter motor and connect the cables.

7. Refill with oil to the correct level.

8. Reinstall the bayonet gauge assembly.

OIL PRESSURE REGULATOR

The oil pressure is automatically controlled or regulated by a compression type spring which controls a relief or by-pass valve. This device is assembled to the cylinder block, see Illustration No. It controls the oil pressure through a predetermined spring pressure and therefore, no adjustment of the oil pressure is required. There is also a high pressure safety relief valve built into the oil pump which prevents the build-up of excessive oil pressure during engine warm-up time, see Illustration No. Figure "A".

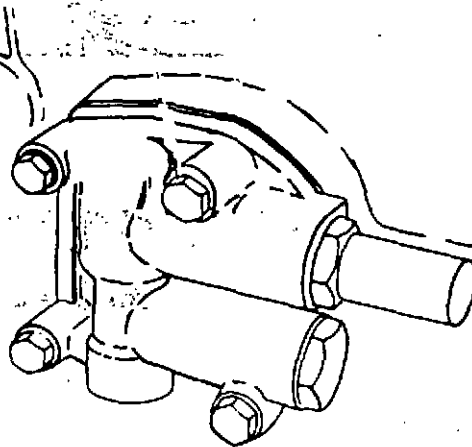

Illustration No. 35

The oil pressure regulator is calibrated to maintain a pressure of 30-65 lbs. in the system. This will vary somewhat with the temperature of the oil and the SAE weight of the oil, also, with the engine speeds.

OIL PUMP

The oil pump is attached to the main bearing cap with suitable screws and is driven by a gear through an idler from the crank gear. See Illustration No. Figure "D". The oil pump has a suction

pipe bolted to the suction side of the pump, which extends down into the oil pan, see Illustration No. The oil is drawn into the pump through a large screen, Fig. "A", which prevents coarse dirt from being drawn into the lubricating oil pump. On some engines, the oil pump also has a scavenge pump section to suck oil out of rear sump and deliver it to front sump, regardless of what angle engine may be. This extends into the oil; therefore, the pump needs no priming. After the oil pan is removed, the oil pump is readily removed for inspection or repairs.

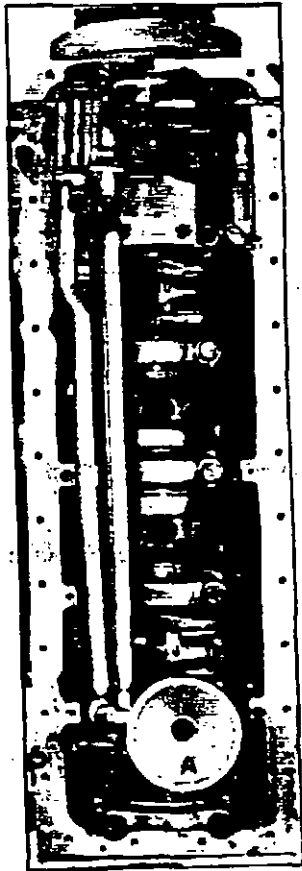

Illustration No. 36.

TO REMOVE THE OIL PUMP.

1. Remove the oil pan. See "Oil Pan".
2. Remove oil pump suction and pressure lines.

3. Remove the screws from the oil pump attaching flange and remove the oil pump from the engine.

TO DISASSEMBLE THE OIL PUMP. (See Illustration No.).

1. Pull gear from shaft with universal gear puller.
2. Inspect pump carefully and replace any worn or defective parts.

TO REASSEMBLE THE OIL PUMP.

1. Press drive gear on to shaft after pump is assembled.

TO INSTALL THE OIL PUMP.

1. Attach the pump to bearing caps and securely bolt in place.
2. Assemble suction and pressure lines to pump and securely fasten to engine with brackets provided.
3. Install the oil pan. See "Oil Pan".
4. Fill the crankcase to the proper level with the correct grade of lubricating oil.

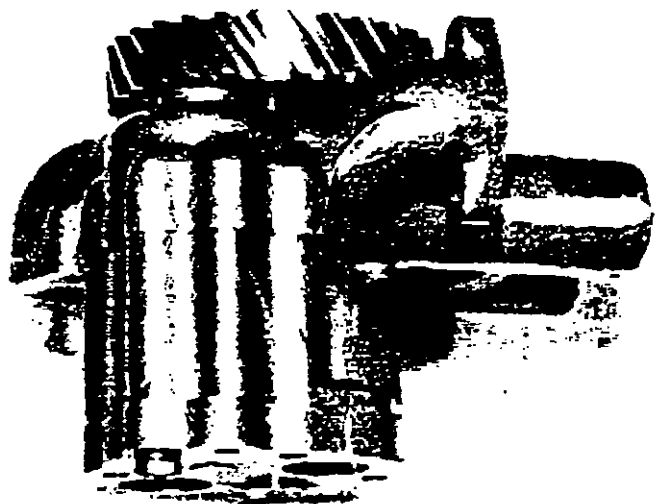
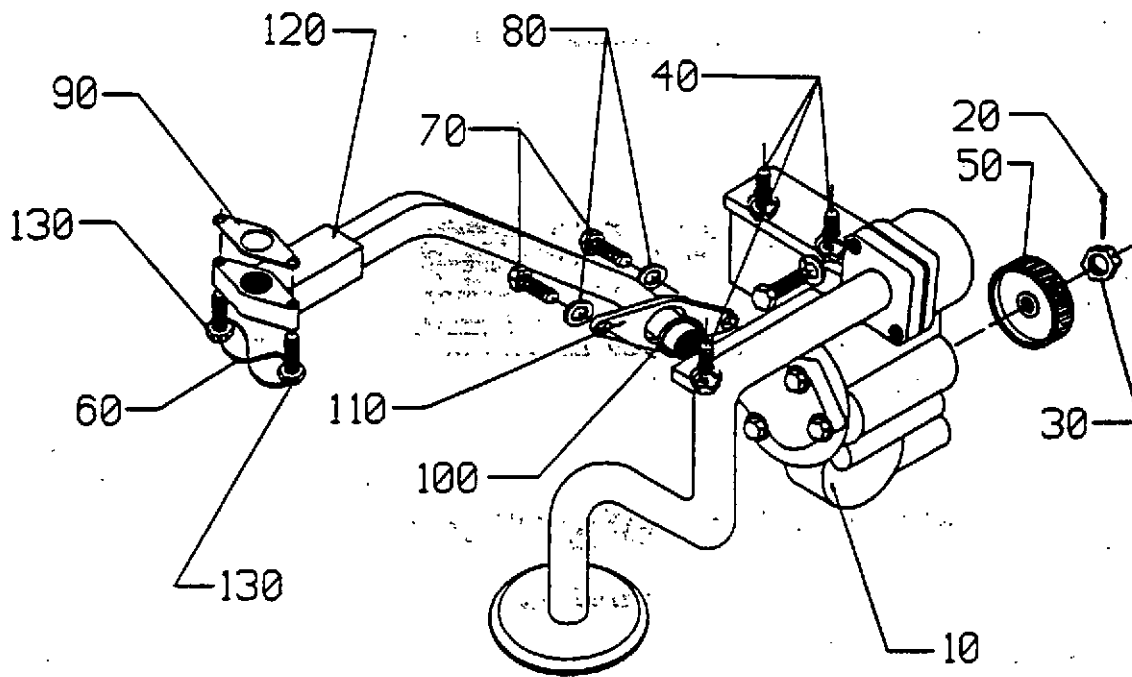

Illustration No. 37.

G-4800 OIL PUMP

High Capacity Oil Pump Pressure Pump Pickup Tube



No.	QTY	COMPONENT
10	1	Assembly, oil pump and line
20	1	Key
30	1	Nut - 1/2-20
40	3	Bolt, oil pump att - 7/16-14 x 1"
50	1	Gear
60	1	Lockwire, pickup tube mtg
70	2	Bolt, pickup tube to pump - 1/4-20 x 3/4"
80	2	Lockwasher, pickup tube to pump - 1/4"
90	1	Gasket, pickup tube mtg
100	1	Packing, pickup tube to pump
110	1	Flange, pickup tube to pump
120	1	Tube Assembly, oil pump pressure outlet
130	2	Bolt, tube att - 5/16-18 x 3/4" (drilled head)

OIL SEAL

The construction of these engines prevents oil leakage when the gaskets are in proper condition and all bolts and screws are properly tightened. Whenever a shaft extends through the engine case and there is a possibility of oil leakage, an oil seal is used, which also acts as a dust seal, preventing dust from entering the engine.

At the flywheel end of the crankshaft, an oil seal is used, Illustration No. 38 and No. . As can be seen in the illustrations, the oil seal is mounted on the engine block so that it seals against the flange of the crankshaft.

The crankshaft is prevented from leaking at the timing gear end by the use of a seal. This seal is pressed into the timing gear cover. See Illustration No.



Illustration No. 38

This type of seal requires very little attention; however, at assembly the shaft seal surfaces on which the seal rides must be thoroughly and carefully checked for nicks or scratches which may have a tendency to damage the seal. If any nicks or scratches are found, they should be removed with an oil stone or very fine every cloth and polished with Crocus cloth. If the shafts have a keyway which might damage the seal during installation, this keyway should be covered with a thin feeler gauge to protect the seal.

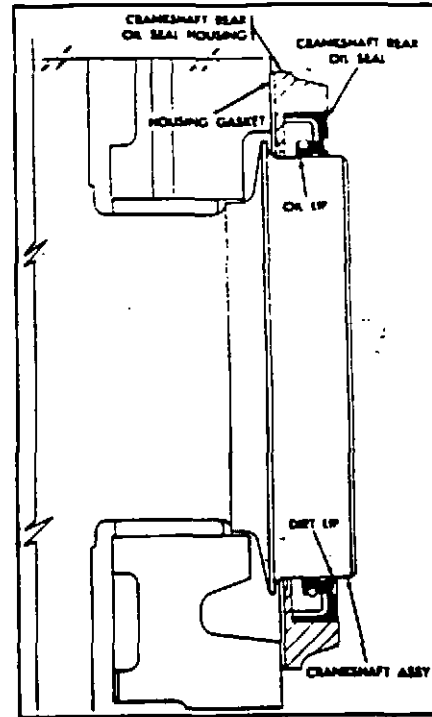
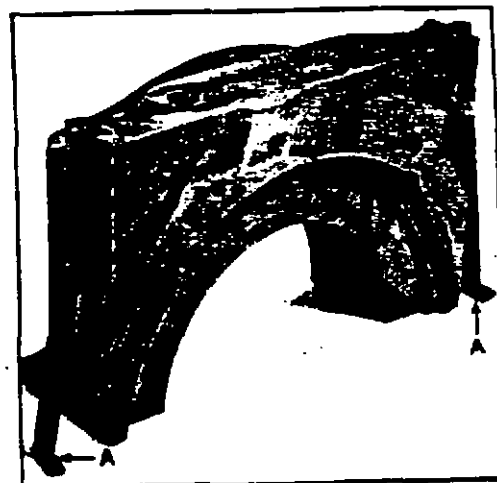

Illustration No. 39.

No special tools are required to install the seals on the shafts. However, a certain amount of care is required in order not to damage the seals. A coating of oil soap on the seal surfaces of the shafts, and also on the seals themselves, will be found beneficial during the run-in period.

INSTALLATION OF REAR OF #7 MAIN BEARING CAP WITH SEALS.

Install seal, Item "A", Illustration No. . in main bearing cap, using Perma Seal No. 2 or its equivalent to hold seals in cap and to make a tight joint between seals and cylinder block. These seals are right to left, so be sure new seals go back in same location as old seals.



Install main bearing cap along with bearing and snug down in place using a straight edge, as shown in Illustration No. 41. Be sure cap is perfectly square with block. This operation is most important or otherwise a leak will develop at this point when crankshaft seal is installed if bearing cap and-block surfaces are not perfectly square with each other.



Illustration No. 41

PISTON

The piston is made of an aluminum alloy and is of the solid skirt type. Three piston rings are used, two rings being compression type, while the third ring from the top, which is above the piston pin, is of the oil regulating type. In addition to the above design, a piston spray nozzle is used. See Lubrication System, Page These nozzles are located on the crankcase next to the main bearing caps and spray oil on the underside of the piston to assist in cooling. The nozzles are located on dowel pins to assure proper alignment with piston.

The pistons should be fitted to the cylinder bores with the proper clearance. See "Fits and Tolerances". If a feeler ribbon is used, this should be a ribbon 1/2" wide.

To remove or install pistons, see "Connecting Rod".

PISTON PIN

The piston pin is a large diameter solid pin of the full floating type. This means that the pin can rotate in either the piston bosses or in the bushing at the top end of the connecting rod. But, the fit in the piston is intended to be much tighter than the fit in the connecting rod; consequently, the movement in the piston consists of a light, creeping action while the normal rotation of the pin occurs in the bushing at the top end of the connecting rod. The piston pin is prevented from moving endwise and making contact with the cylinder wall by means of snap rings, which locate in grooves machined in the bosses of the piston. Piston pins should be fit in the piston bosses with the proper clearance, as indicated in the "Fits and Tolerances Table". See Illustration No.

NOTE: At re-assembly assure that the piston retaining ring opening is facing down as shown in Illustration No.

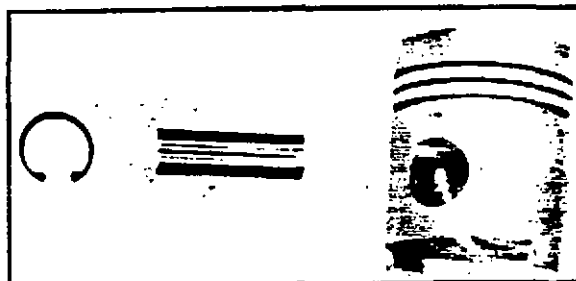

Illustration No. 42

PISTON RINGS

The piston rings, when fitted in the cylinder bore of the engine, should have a gap clearance as indicated in the "Fits and Tolerances Table".

When installing new piston rings, each ring should be tried in the cylinder bore to see if it has the correct gap clearance. If necessary to increase the gap, the ring should be held and filed as shown in Illustration No. If the ring is held in a vise, the vise jaws must be covered with some soft metal. The ends of the rings are squeezed to-

gether and the file cuts on both sides. This will insure the ends being parallel. When inserting the ring in the cylinder bore to test the gap clearance, push the ring part way through the bore, using the top of a piston to square the ring in the bore.

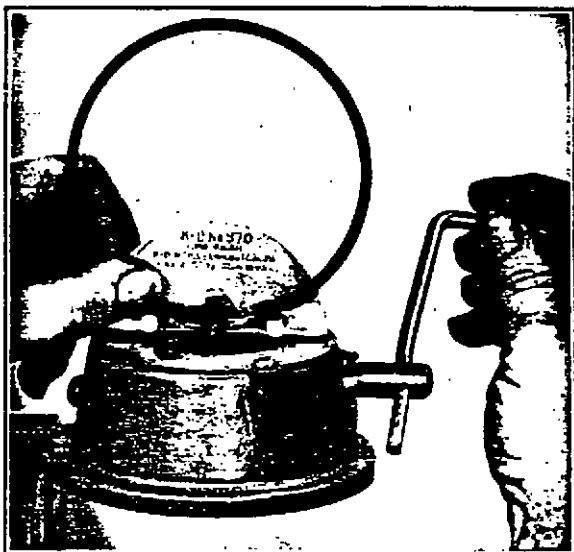

Illustration No. 43

Each new ring should be tried for clearance in the piston groove by rolling the ring all the way around the groove. If the piston grooves have been carefully cleaned, the rings will be found to fit correctly; but, if they are tight, they can be lapped slightly on a sheet of emery cloth (No. 000) laid on a flat surface. If rings are loose in groove and clearance is more than that specified in "Fits and Tolerances", replace piston.

When assembling the piston rings to the piston, if a ring spreader tool is not available, the rings can be slipped over thin strips of metal. Whatever method is used, the rings must be handled carefully in order not to distort or break them.

TERMOSTAT AND BYPASS

The engines are equipped with a thermostat, Illustration No. 46, so designed that it will not allow water from the radiator to circulate through the engine until the water in the engine is at

operating temperature, but does bypass a certain amount of water from the cylinder block, which is carried through the by-pass tube to the inlet side of the water pump, where it is again circulated through the engine. This is repeated until the water in the engine is heated to operating temperature, when the thermostat begins to open and permits the water from the engine to enter the radiator. This water is, at the same time, replaced in the engine by the water pump drawing from the bottom of the radiator. Thus, the water temperature is constantly maintained in the proper heat range.

A defective thermostat of this type must be replaced as it cannot be repaired. The thermostat should be completely open at temperature marked on the thermostat in the still water test.

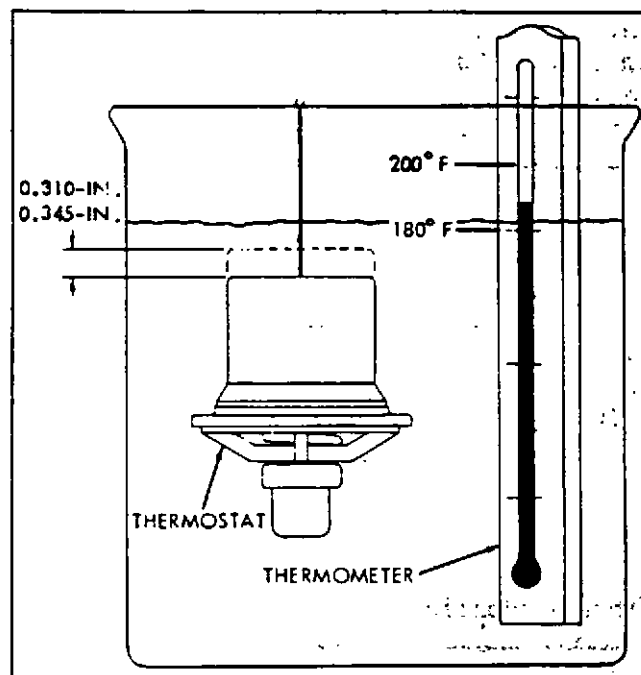

Illustration No. 45

The still water test is as follows:

Place approximately 4" of water in a pan or pail. Insert a thermometer of this heat range in the water and set the thermostat in the water with the bellows submerged. Heat the water slowly and carefully observe when the thermostat valve is fully open and note the water temperature. Then compare this tempera-

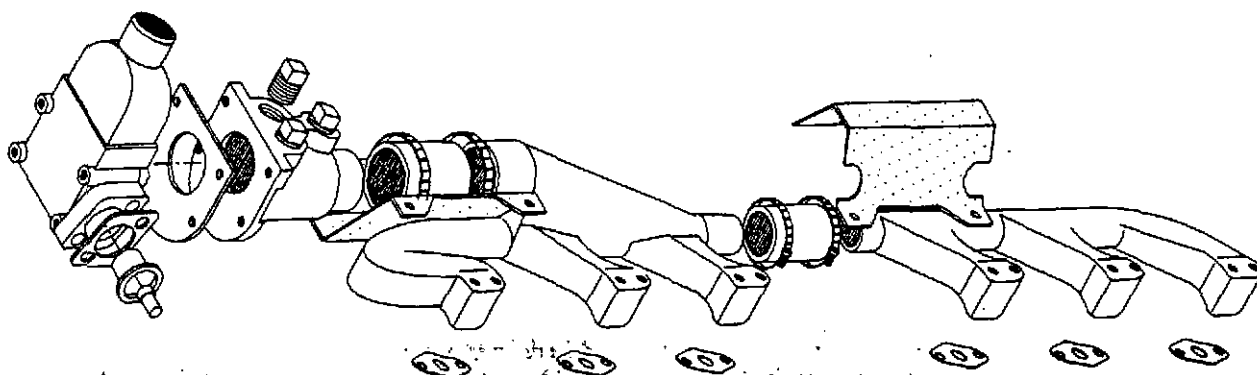

Illustration No. 46

ture with that stamped on the thermostat. (See Illustration No. 45.

Five degrees above or under those given are permissible.

TURBOCHARGER

The turbocharger is a self-contained unit composed of a gas turbine and a centrifugal blower mounted on a common shaft with the necessary surrounding castings. The exhaust gas from the engine is forced into the turbine side of the turbocharger, where the energy of the gas is used to drive the turbine. The blower mounted on the opposite end of the shaft forces air under pressure into the intake system. By providing a greater amount of fresh air, a greater amount of fuel can be burned. This increases power output from the turbocharged engine.

The action of the turbocharger is entirely automatic and requires no control. The speed and output of the turbocharger will vary automatically with variations of engine load or speed, or both.

Turbochargers are ruggedly constructed and have a rotor assembly which is fitted and finely balanced to operate at speeds which may exceed 90,000 rpm. Rotating force is obtained from hot exhaust gases which rotate the turbine rotor. This rotating force is transmitted through a sleeve-bearing supported shaft to a second rotor which draws in fresh, cool air and compresses it in the intake manifold system from which they cylinders are charged as the intake valves open. The shaft and sleeve bear-

ing are lubricated and cooled by filtered engine lubricating oil.

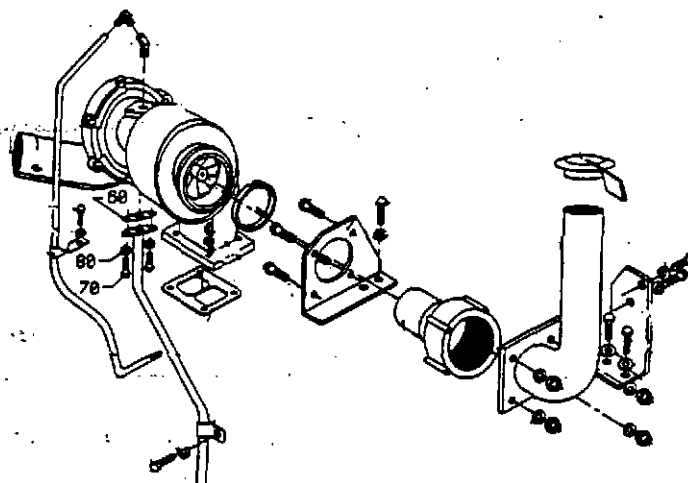

Illustration No. 47

The exhaust system of a turbocharged engine installation must be very carefully designed to eliminate restriction of the free flow of exhaust gases from the turbocharger. The turbocharger exhaust outlet pipe flange is normally shipped with engine equipped with turbochargers. The flange is threaded to accept the recommended size outlet pipe. No reduction in this pipe size is permissible. Bends or turns in the outlet pipe must be limited to a minimum radius of 12 inches. For installation requiring a radius less than 12 inches, write to Hercules Engines, Inc. Engineering Department, P. O. Box 24101, Canton, Ohio 44701 U.S.A. for specific recommendations.

NOTE: Back pressure in the exhaust system, measured near the turbocharger should not exceed 2.5" Hg or 35" H₂O. An increase in exhaust back pressure will result in a corresponding decrease in engine power output.

Mufflers can be used. Contact the factory for muffler specification for turbocharger-equipped engines.

NOTE: Turbocharger repairs should be made only by authorized service centers or competent turbocharger technicians.

BASIC SAFETY PRECAUTIONS

Misuse, misapplication or modification of the turbocharger can result in serious injury and property damage. Basic safety precautions including the following should always be followed:

1. Install turbocharger only on an engine which has been approved for such application. The turbocharger is a precision built product which has been matched and tested for use on specific engines only.
2. DO NOT modify or substitute any parts of the turbocharger.
3. Do not modify or substitute any parts of engine except in accordance with engine owner's manual. DO NOT modify engine fuel control system or restrict exhaust system or air inlet.
4. Do not operate at excessive altitudes.
5. Do not modify oil supply system or decrease the diameter of the oil drain line.
6. Always warm up the engine to allow warm oil to reach the turbocharger before operating under load.

VALVES

The intake and exhaust valves are made of special steel with a stellite finish, and operate in valve guides pressed into the cylinder head. They are held on to their seats by strong steel springs, which are fastened to the valves by suitable spring seats and valve lock arrangement. The valves, being located in the cylinder head, are operated by conventional type tappets with hollow

push rods running from the tappets to the rocker arms. The rocker arms are lubricated by means of oil forced through a drilled hole in the rocker arm support into the shaft on which they rotate. Oil is forced out through small holes in the rocker arms, over the valve stems and push rods. The replacement of valve tappets will be found under the subject of "Valve Tappets".

In order to continue to get good performance from an engine, it may be necessary to grind or reset the valves at varying intervals. The frequency for doing this depends on the care in the operation of the engine. If the air cleaners have been properly cared for; if all connections between the air cleaner and engine have been kept air tight; if the lubricating oil has been properly maintained; and if the clearance between the valve stem and rocker arm has been properly adjusted, valve grinding will be necessary very infrequently. Their seating should be tested periodically by rocking the engine against compression. When the engine will not rock, compression is leaking through either the valves, cylinder head gasket or past the piston rings. Check the leak by listening for a "hissing" sound, when the engine is cranked by hand, either at the cylinder head gasket area or the breather. If at the cylinder head gasket, remove the head and replace the gasket. If in the breather, dismantle the engine and install new parts for those found worn or scored. If no "hissing" is heard at either of these two places, remove the cylinder head and valves. Clean both thoroughly, removing all carbon and oil. Inspect the valve seats and valves. See "Valve Grinding".

TO REMOVE THE VALVES.

1. Remove the cylinder head. See "Cylinder Head".
2. With a clamp type valve spring compressor, compress the valve springs and remove the valve spring locks.

3. Remove the valve springs, valve stem seals, and seats and lift out the valves. Place the valves in a cardboard or wood block, drilled and numbered so that the valves may be reinstalled in their respective places when grinding or reassembling (do not mark the valves with a file or punch).

4. Clean all carbon from the cylinder head, piston heads, valve seats, valve guides and valves with suitable scraping or buffing tools.

VALVE GRINDING

Inspect the valve guides for excessive wear. If the valve guides are to be renewed, this should be done before any work is done on the valve seats. This will insure the seat being finished square with respect to the new guide. The exhaust valve guides will usually show the most wear. To drive out the guides, use a drift with a pilot sized to the I.D. of the valve guide. Drive in the new guides to the same depth location as the old guides. See Illustration No. 48, also see "Fits and Tolerances".

Illustration No. 48

VALVE SEAT GRINDING

When valve seats can be repaired by regrinding or when valve seats are replaced, grind as described:

1. Use a 30° angle grinding stone to grind valve seats.

2. After grinding seat, check valve contact. See Illustration No.

3. Keep valve seat as near as possible to center of valve face.

Narrow seat as necessary, using a 20° grinding stone. Valve should never seat at the top or bottom of the face.

Illustration No. 49.

VALVE SEAT REPLACEMENT.

Replace valve seats that cannot be repaired by grinding. Remove seat using any method which will not damage counterbore of cylinder head machined surface. Install new intake valve seat and exhaust valve seat. Grind seat as described in No. 1 above.

Inspect the valve seats; and, if they are pitted or if new guides have been installed, the seats should be refinished. Valve seat tools with proper diameter pilots are required. The exhaust valve seats are round. The intake valve seats are finished on a 30° angle. Reseat the seats with a vibrating angle grinder type reseating tool. Because of the large diameter and surface of the valve seats, it is very difficult to obtain a good reseating job with a reamer type tool. Remove all shoulders and pits from the seat but do not grind any deeper than necessary. Then finish the

new or refaced valve to the reseated seat by hand in the usual manner. See Illustration No. 49.

Inspect the valves carefully, and if the stems are badly worn, or are not straight, or if the valves are deeply pitted, the valves should be replaced by new ones. However, valves that are only slightly pitted can be used by refacing them on a valve grinder. Valves must have an accurately finished face of the correct angle. See "Fits and Tolerances" for the seat face width.

If the valves and seats are not deeply pitted or shouldered, or have been refaced, grind or lap each valve to its seat. Obtain a light coil spring with enough tension to just hold the valve off the seat. Lubricate the valve stem and apply a thin coating of good quality, medium grinding compound on the valve face. Insert the valve in the valve guide and rotate the valve back and forth, about a quarter of a turn, a few times, pressing firmly on the grinding tool. (Avoid continuous round-and-round motion that would cut grooves in the valves or seat). Release the pressure on the tool and the spring should lift the valve from its seat. Rotate the valve 15° or 20° and repeat the grinding process. It will probably be necessary to wipe off and inspect the valve and seat during this process to see what progress is being made; also, the compound may wear off the surface being ground. In either case, reapply another thin coating of compound and continue grinding until inspection shows the surfaces are in contact. Then wipe off all heavy compound and apply a thin coating of "fine" compound and continue the grinding. When the surfaces are "finished" and show a bright, silver-like band of uniform width on both the valve and seat, clean off all traces of the compound. Test each valve for a tight fit by making ten or twelve pencil marks equally spaced across the turn and again lift out the valve and observe if all the pencil marks are rubbed out on the contact surface. If not, regrind until this test shows a gas tight mating of the valve and seat.

NOTE: It is imperative that the valves be assembled in the same seats to which they were ground.

TO ASSEMBLE THE VALVES.

1. Thoroughly clean all traces of the grinding compound off the valves, stems, and guides; put a few drops of oil on the valve stems and insert the valves. Install the valve stem seals.

NOTE: Valve stem seals must be installed with the Hercules valve seal installation tool. Part No. 40-3104703.

2. Using a valve spring compressor, compress the valve springs and insert the valve locks.

3. Turn the head on its side and pour gasoline in the valve openings. If gasoline seeps out around any valve seat, remove that valve and regrind. Repeat the test.

4. Install a new cylinder head gasket on the engine. See "Cylinder Head".

5. Install the cylinder head assembly. See "Cylinder Head".

5. Adjust the valve tappets, Illustration No. 50, to the proper setting. See "Fits and Tolerances". This may be readily and systematically accomplished in the following manner. Perusal of the following paragraphs and Illustration No. will point out that the spotting of the crankshaft and rocker arms follows the firing order (1-5-3-6-2-4) of the engine (starting from the timing gear end). The valve tappet screws have a locknut which must be securely locked.

a. Crank the engine over until both the intake and exhaust valve of No. 1 cylinder are closed. Then adjust the tappets on this cylinder. Repeat this on all cylinders following the engine firing order of 1-5-3-6-2-4, or set the tappets as follows:

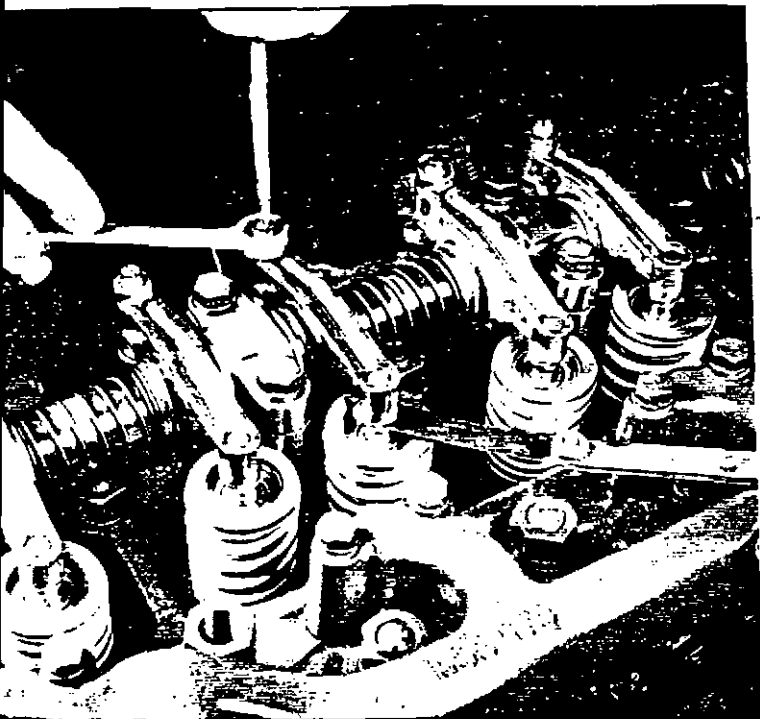

Illustration No.

For ease of adjustment, note the following:

With cylinder No. 1 intake valve wide open, clearance can be adjusted on cylinder numbers 2, 3, and 6 intake valves and cylinder numbers 1, 2, and 4 exhaust valves. With cylinder No. 6 intake valve wide open, clearance can be adjusted on cylinder numbers 1, 4, and 5 intake valves and cylinders numbers 3, 5, and 6 exhaust valves.

The above completes the valve tappet adjustment until after the engine is started and warmed up to operating temperatures, at which time the valve tappets should be readjusted to the correct hot operating clearance.

6. Install the cylinder head cover and any other parts that may have been removed.

WATER PUMP AND FAN ASSEMBLY

7. Fill the cooling system with water or a cooling solution. Start the engine and warm up to operating temperatures.

8. With the engine idling slowly, readjust the tappets to the correct operating clearance.

VALVE TAPPETS

The valve tappet is straight and is hollow to receive the push rods.

TO REMOVE THE VALVE TAPPETS.

1. Remove the rocker arms and push rods. See "Camshaft Removal".
2. Remove the tappets from the cylinder block. See Illustration No. 51.
3. Check the tappets for wear and replace any that have excessive clearance.

TO INSTALL THE VALVE TAPPETS.

1. Check each tappet in the cylinder block position to see that it has the correct clearance, see "Fits and Tolerances", and install the tappets.
2. Adjust the valves. See "Valve Grinding".

This section (See following page) shows a breakdown of the water pump as used on these engines.

This pump may be readily removed from the engine after the removal of the water inlet hose, by-pass hose and fan blade.

Then remove the water pump to cylinder block attaching screws and lift the pump away from the engine.

WATER PUMP RE-BUILD INSTRUCTIONS

IMPORTANT: Remove dirt, dust or other foreign material from body and housing before disassembly.

1. DISASSEMBLY: (See Figure 4)

A. Remove screws (11) and washers (12) from housing flange.

B. Remove housing assembly (4) from body (2). Remove gasket (3) and discard.

C. Remove pulley from drive shaft with a gear puller or arbor press.

D. Remove snap ring (10) from housing assembly (4).

CAUTION: Do not attempt to hammer or pry impeller (5) from impeller shaft (9). Damage to housing (8) can result.

E. Place housing assembly (4) in arbor press with impeller (5) facing up, refer to figure 1. Press impeller shaft (9) through impeller (5) and from housing (8).

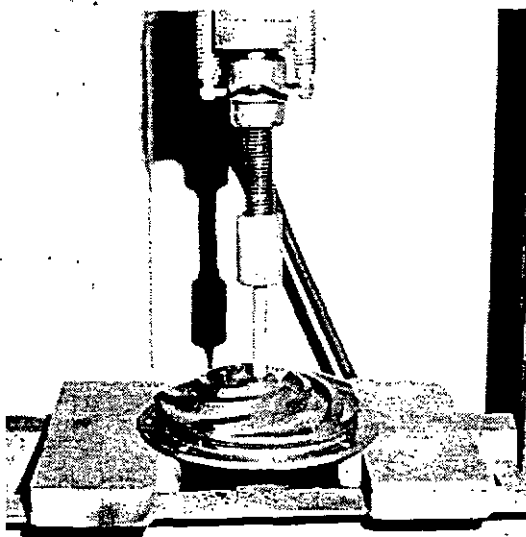

Figure 1. Impeller Removal

F. Remove and discard seal assembly (6), impeller shaft seal (7) and shaft (9).

2. CLEANING.

WARNING: CLEANING SOLVENTS ARE TOXIC AND USUALLY FLAMMABLE. USE ONLY IN A WELL VENTILATED AREA, AND KEEP AWAY FROM OPEN FLAMES.

A. Clean pulley, housing (8) and body (2) thoroughly in solvent to remove dirt or foreign deposits. As required, use a wire brush to remove any built up corrosion.

B. Do not mar or scratch mating surfaces of housing (8) and body (2). Do not remove metal from inner bore of housing (8) or pulley.

C. Dry all parts with compressed air or a clean cloth to remove all solvent.

3. INSPECTION.

A. Inspect pulley for cracks and/or distortion. Check pulley grooves for rust or rough spots.

B. Inspect pump body (2) for cracks and worn or damaged threads. Replace or salvage as necessary.

C. Inspect pump housing (8) for cracks or for oversize bearing bore.

4. REPAIR.

Correction of defects found during inspection should be limited to removal of scratches and burrs on mating surfaces or where seals/gaskets will be installed using fine emery cloth. Damaged threads can be "chased" using the same size tap.

Parts showing cracks or excessive deformity should be replaced, not repaired.

5. ASSEMBLY.

A. Lubricate bearing bore in housing (8) and impeller shaft (9).

B. Use proper size driver to press on the outer bearing assembly. Press impeller shaft (9) into housing (8)...

C. Install snap ring (10) in groove of housing (8).

D. Turn housing (8) and impeller shaft (9) over on press. Using a small amount of sealer on the outer side of seal (7), install seal (7) over shaft (9) and press seal (7) into housing (8) by pressing on the outside or brass part of seal (7).

E. Lubricate the shaft (9) and install the seal assembly (two parts) (6) with ceramic side toward impeller shaft seal (7).

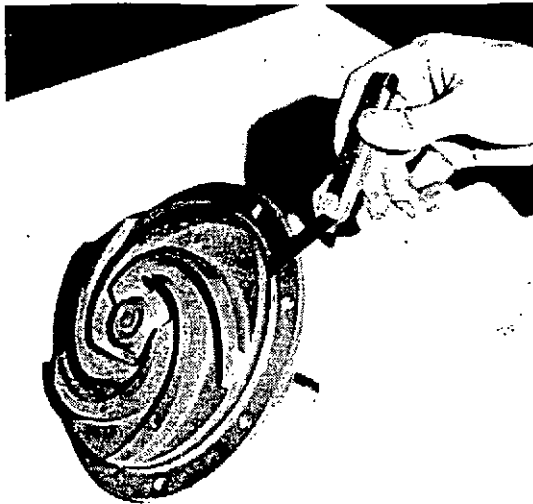

Figure 2. Impeller Installation

F. Coat end of impeller shaft (9) with Loctite, grade 601. Position housing (8) and impeller shaft (9) in arbor press so they are supported by impeller shaft (9). Press impeller (5) onto impeller shaft (9). Impeller (5) is correctly installed when 0.100 inches clearance exists between impeller (5) and housing (9), refer to figure 2.

G. Turn housing (8) over. Roughen surface of drive shaft (9) with coarse

emery cloth. Coat the pulley bore and impeller shaft (9) with Loctite, grade 601.

H. Install pulley on impeller shaft (9) using an arbor press. Place assembly in arbor press so load is on impeller shaft (9) and not impeller (5).

IMPORTANT: There must be a measurement from the top of pulley and mating surface of housing (8). Refer to Figure 3.

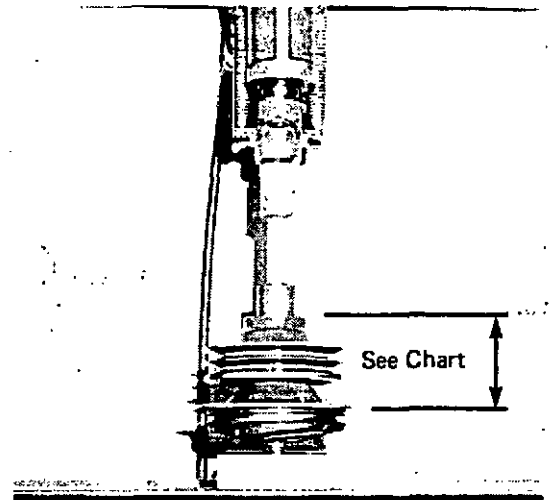

Figure 3. Assembly Measurements

I. Spin impeller (5) by hand. Check that impeller (5) does not touch housing (8) at any point. If it does, re-check clearance as shown in Figure 2.

J. Install gasket (3) and housing assembly (4) on body (2). Align holes and install screws (11) and washers (12). Tighten screws progressively, in a cirss-cross pattern, to a final torque of 16 ft-lbs.

Pump Assy. Part No.	Housing Assy. Part No.	Pulley Part No.	Dim.-Top of Pulley to Mating Surface of Impeller
40-3835069	40-3835254	380374 2 Groove	4.410

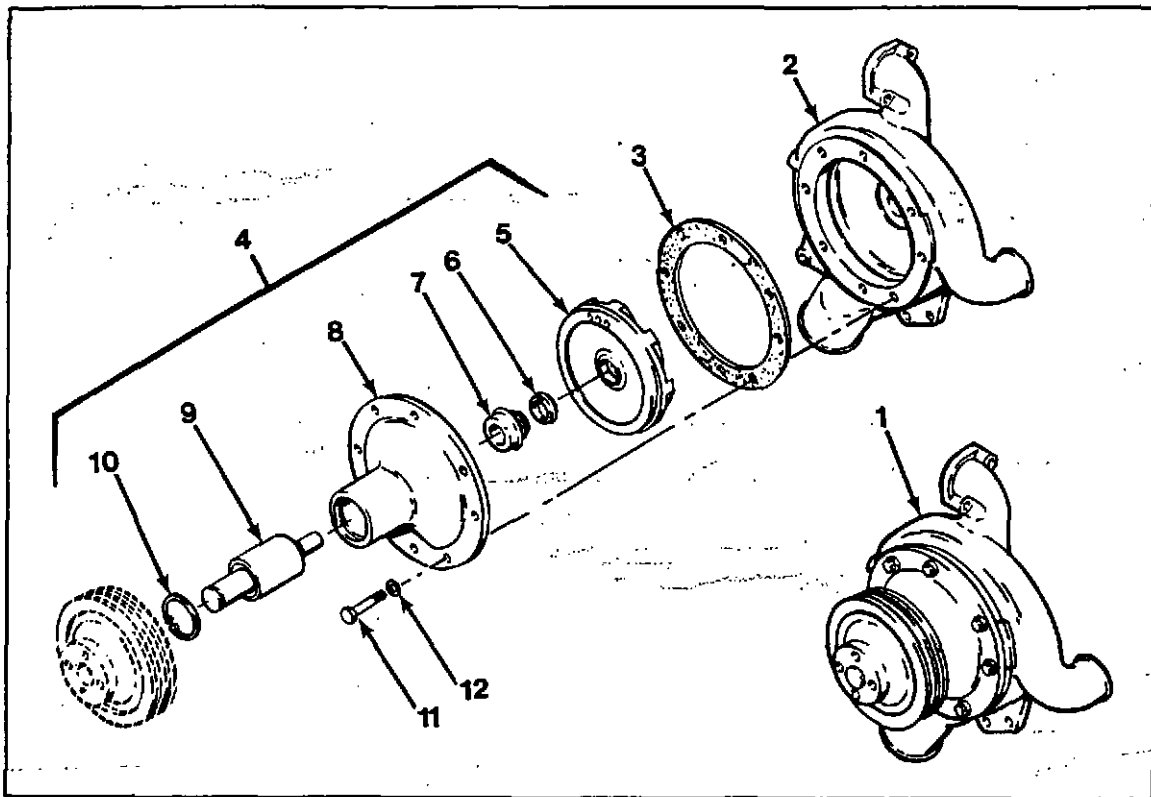

Figure 4. Water Pump Assembly

REF.	DESCRIPTION	QTY.
1	WATER PUMP ASSEMBLY, MODEL D-4800	1
2	.BODY, PUMP	1
3	.GASKET, HOUSING	1
4	.HOUSING ASSEMBLY	1
5	..IMPELLER	1
6	..SEAL ASSEMBLY (TWO PARTS)	1
7	..SEAL, IMPELLER SHAFT	1
8	..HOUSING, PUMP	1
9	..SHAFT, IMPELLER	1
10	..RING, SNAP	1
11 COMMERCIAL	.SCREW, CAP, HEX HD	8
12 COMMERCIAL	.WASHER, FLAT	8

WIRING DIAGRAM

Due to many types of electrical equipment and the variety of requirements encountered in different installations, it is impossible to illustrate a typical wiring diagram.

However, the installation of wiring circuits may be more readily understood if the complete system is divided as follows:

1. THE STARTER SYSTEM

This circuit consists of the battery (electrical energy storage unit), the starting motor and the necessary wiring to connect the battery to the starter switch and from the starter switch to the starter.

In most cases, the ground or return flow of current is carried through the frame work of the unit to a point near the battery from where a short cable is connected to the battery to complete the circuit.

When a magnetic type starter switch is used, it is necessary to connect it to a control switch, which may be either a key switch or a simple push button switch. The key switch has one side connected to the battery side of the ammeter and the other side to the magnetic switch with suitable wires. The magnetic switch may have an external ground post which must be grounded to the unit framework. The push button switch has one side connected to the battery side of the ammeter and the opposite side connected to the magnetic starter switch as outlined above.

2. BATTERY CHARGING SYSTEM

The battery charging system consists of an alternator, which creates the electrical current, a regulator to control the current, and an ammeter to indicate the amount of current being crated or used.

3. ACCESSORY SYSTEM

The accessory system consists of lights, horns, heaters, etc. The current to operate these accessories is usually taken from the ammeter to a suitable switch, which allows the accessories to be operated or turned off as necessary.



HERCULES ENGINE COMPANY

101 Eleventh St., S.E., Canton, Ohio 44707-3802

Parts (216) 438-1025

FAX: (216) 438-1030

Service (216) 438-1035