

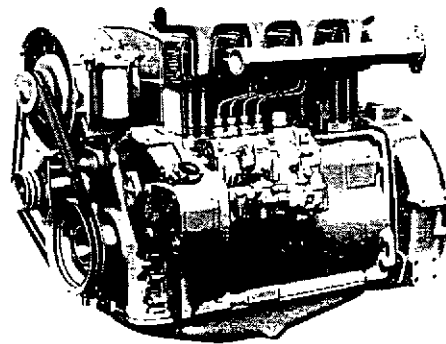

OPERATING and  
MAINTENANCE INSTRUCTIONS  
for

**D 327**



Please read carefully PRIOR TO putting  
the engine into operation

It will be well worth your while . . .

... to read these Operating Instructions from cover to cover prior to putting the engine into operation.

For they are designed to familiarize you with engine operation and help you maintain its reliability.

Engine construction, operation and control are described for this purpose.

The necessary care and maintenance is summarized in a maintenance chart, the individual maintenance operations being explained with reference to illustrations.

The TROUBLE SHOOTING CHART is intended to help you remedy trouble quickly and reliably.

Our service points will be happy to supply any other details you need in connection with these Operating Instructions.



**MURPHY DIESEL CO.**  
**5317 W. Burnham St.**  
**Milwaukee, Wisconsin 53219**

| Contents   | Page      |
|--|-----------|
| <b>1. Engine Characteristics</b>                   | <b>2</b>  |
| <b>2. Engine Illustrations with Exterior Parts</b> | <b>3</b>  |
| 1. Table of Oil Quantities                         | 4         |
| <b>3. Internal Engine Construction</b>             | <b>8</b>  |
| 1. Operating principle                             | 8         |
| 2. Sectional views                                 | 9         |
| 3. Fuel system                                     | 11        |
| 4. Governor  | 12        |
| 5. Lubrication system                              | 13        |
| 6. Air cooling                                     | 14        |
| 7. Circuit diagram                                 | 15        |
| <b>4. Putting into Service and Operating</b>       | <b>16</b> |
| 1. Filling up with oil                             | 16        |
| 2. Venting fuel system                             | 18        |
| 3. Starting  | 19        |
| 4. Adjusting speed                                 | 20        |
| 5. Stopping  | 20        |
| <b>5. Maintenance, Maintenance Chart</b>           | <b>21</b> |
| 1. Filling fuel tank, venting                      | 22        |
| 2. Oil level                                       | 22        |
| 3. Bolted joints                                   | 22        |
| 4. Changing oil                                    | 23        |
| 5. Injection pump, oil level                       | 23        |
| 6. V-belt  | 24        |
| 7. Air filter                                      | 24        |
| 8. Engine breather                                 | 25        |
| 9. Battery   | 25        |
| 10. Valve clearance                                | 25        |
| 11. Cooling ribs                                   | 26        |
| 12. Exchangeable fuel filter                       | 26        |
| 13. Injectors                                      | 26        |
| 14. Injection pump — oil change                    | 27        |
| 15. Compression pressure                           | 27        |
| 16. Fan bearings                                   | 28        |
| 17. Protecting engine                              | 28        |
| <b>6. TROUBLE SHOOTING CHART</b>                   | <b>29</b> |

| 1. Engine Characteristics                                       |                    | D 327-2                       | D 327-3                  | D 327-4  | D 327-6     |
|---|--------------------|-------------------------------|--------------------------|----------|-------------|
| <b>1.1 Specifications</b>                                       |                    |                               |                          |          |             |
| Number of cylinders   |                    | 2                             | 3                        | 4        | 6           |
| Combustion cycle  |                    | 4-stroke                      |                          |          |             |
| Combustion system   |                    | direct injection              |                          |          |             |
| Bore/stroke   | mm                 | 100/120                       |                          |          |             |
| Total displacement  | cm <sup>3</sup>    | 1884                          | 2826                     | 3768     | 5652        |
| Compression ratio   |                    | 1 : 18                        |                          |          |             |
| Direction of rotation   |                    | left-hand looking at flywheel |                          |          |             |
| Firing order  |                    | 1-2                           | 1-3-2                    | 1-3-4-2  | 1-5-3-6-2-4 |
| <b>1.2 Performance Data (full load)</b>                         |                    |                               |                          |          |             |
| Working speed, max.   | min <sup>-1</sup>  | 3000                          |                          |          |             |
| Idle speed, min.  | min <sup>-1</sup>  | 650                           |                          |          |             |
| Continuous output B<br>at n = 3000                              | kW(HP)             | 23.5(32)                      | 35.3(48)                 | 47(64)   | 70.6(96)    |
| Ignition pressure, max.   | bar                | 85                            |                          |          |             |
| Injection pressure  | bar                | 180                           |                          |          |             |
| Compression pressure<br>(measured with engine cold)             | bar                | 30(new)                       | 25(lower boundary value) |          |             |
| Valve clearance<br>(engine cold)                                | mm                 | 0.2                           |                          |          |             |
| Fuel consumption approx.  | dm <sup>3</sup> /h | 7.8                           | 11                       | 15       | 22          |
| Lube oil consumption approx.                                    | g/h                | 40...50                       | 65...75                  | 90...100 | 140...150   |
| Cooling air delivery, max.                                      | m <sup>3</sup> /h  | 2000                          | 2200                     | 3600     | 4100        |
| Working angle   |                    | see table, pages 4 to 7       |                          |          |             |
| <b>1.3 Operating Temperatures</b>                               |                    |                               |                          |          |             |
| Lube oil, max.  | degrees            | 115°C                         |                          |          |             |
| Exhaust manifold temperature, max.                              | degrees            | 600°C                         |                          |          |             |
| Temperature difference<br>between individual cylinders,<br>max. | degrees            | 30°C                          |                          |          |             |
| <b>1.4 Capacity (lube oil)</b>                                  |                    | see table, pages 4 to 7       |                          |          |             |
| <b>1.5 Engine weight (dry)</b>                                  |                    |                               |                          |          |             |
| Built-in version kg   | approx.            | 230                           | 280                      | 325      | 425         |

## 2. Engine illustrations with exterior parts

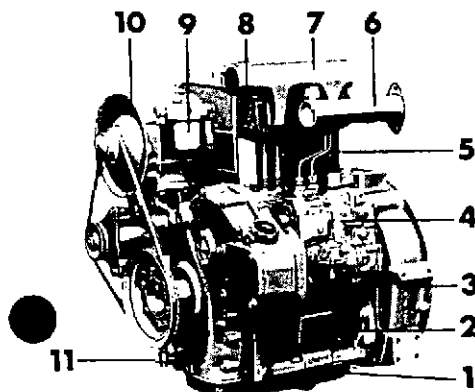

D 327-2

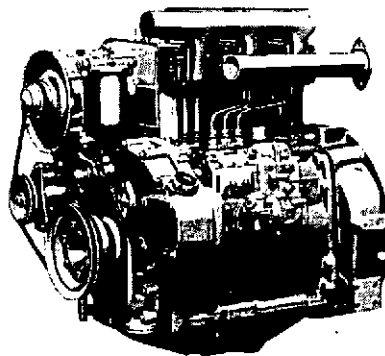

D 327-3

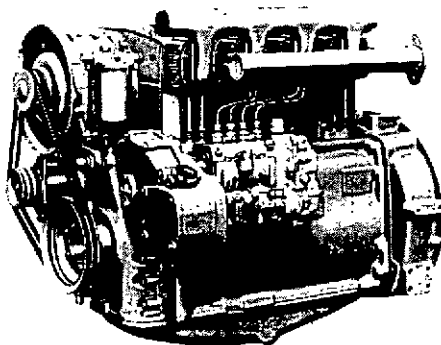

D 327-4

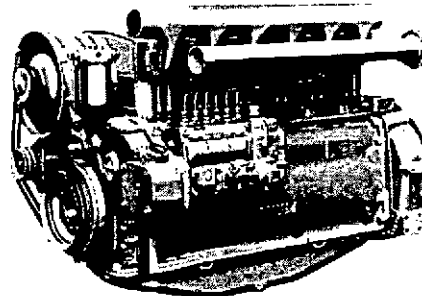

D 327-6

- 1 Oil sump (see pages 4 to 7 for types)
- 2 Crankcase
- 3 Flywheel housing
- 4 Injection pump and governor
- 5 Cylinder

- 6 Exhaust pipe
- 7 Intake pipe
- 8 Cylinder head
- 9 Fuel filter
- 10 Fan
- 11 End cover







## 2.1 Oil capacity and working angles

The oil capacity and safe working angle depend on a variety of mounting conditions which in turn dictate different types of oil sump. These oil sumps are shown in the following table, indicating which type is attached to which engine.

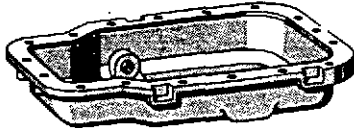

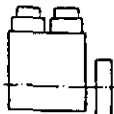
The accompanying oil dipsticks, oil capacities and maximum permissible working angles are shown with each illustration.

The code letters have the following meanings:

- A = Oil quantity (dm<sup>3</sup>) at oil change with filter change
- B = Oil quantity at oil change without filter change (top mark on dipstick)
- C = Smallest permissible oil quantity in engine (bottom mark on dipstick)
- D = Quantity to top up from bottom to top marks on dipstick
- L = Maximum permissible working angle, lengthwise
- Q = Maximum permissible working angle crosswise

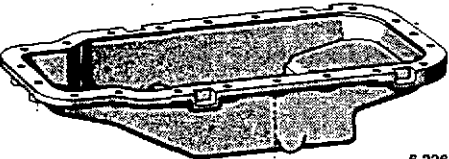
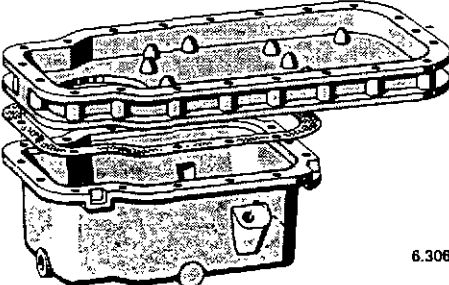
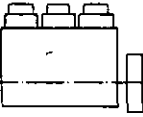
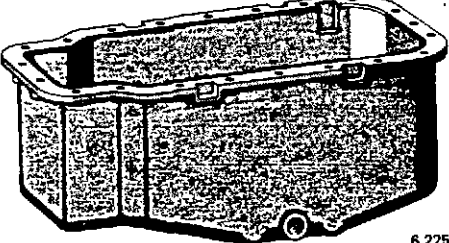
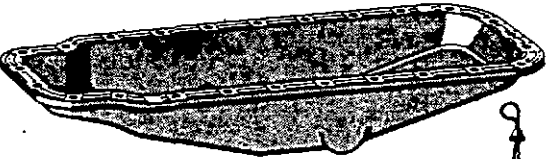
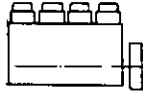
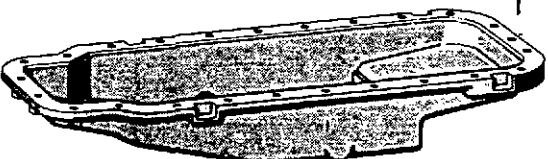
| Oil sump type and part No.   | Accompanying oil dipstick  | Capacities/<br>max. angles   | Engine ill./<br>cyl. No.  |
|--|--|--|---|
| 6.325.0.115.022.6 (Guß/cast)<br>      |  | dm <sup>3</sup> (ltr.)<br>A = 5,5<br>B = 5,0<br>C = 3,0<br>D = 2,0<br>L = 30°<br>Q = 30° |   |
| 6.325.0.115.042.6 (Blech/plate)<br>  | <br>6.325.0.329.002.4  | A = 5,75<br>B = 5,25<br>C = 3,25<br>D = 2,0<br>L = 30°<br>Q = 30°                        | 2-cylinder<br>  |
| 6.325.0.115.012.6 (Blech/plate)<br> |  |  |   |
| 6.325.0.115.013.6 (Blech/plate)<br> | <br>8.226.0.329.001.4 | A = 7,75<br>B = 7,25<br>C = 4,0<br>D = 3,25<br>L = 25°<br>Q = 35°                        | 3-cylinder<br> |

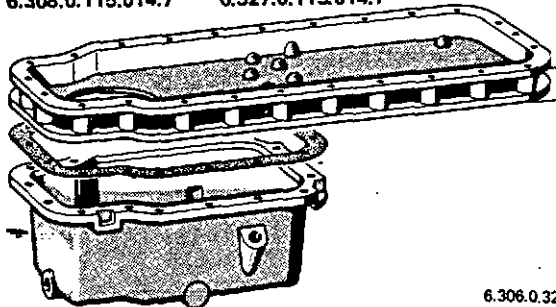
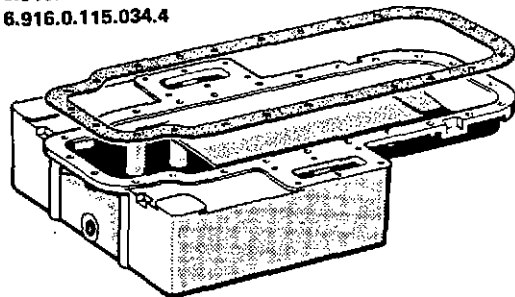
|   |   |   |
|---|---|---|
| <p>6.325.0.115.023.4 (Guß/cast)</p>  <p>6.226.0.329.001.4</p>            | <p>dm<sup>3</sup> (litr.)</p> <p>A = 7,25<br/>B = 6,75<br/>C = 3,5<br/>D = 3,25<br/>L = 25°<br/>Q = 35°</p> |   |
| <p>6.306.0.115.003.7<br/>6.308.0.115.013.7</p>  <p>6.306.0.329.001.5</p> | <p>A = 7,25<br/>B = 6,75<br/>C = 4,0<br/>D = 2,75<br/>L = 45°<br/>Q = 45°</p>                               | <p>3-cylinder</p>    |
| <p>6.225.0.115.003.4</p>  <p>6.225.0.329.001.5</p>                       | <p>A = 22,0<br/>B = 21,0<br/>C = 4,0<br/>D = 17,0<br/>L = -<br/>Q = -</p>                                   |   |
| <p>6.325.0.115.044.6</p>  <p>6.325.0.329.002.4</p>                     | <p>A = 10,25<br/>B = 9,5<br/>C = 4,5<br/>D = 5,0<br/>L = 20°<br/>Q = 35°</p>                                | <p>4-cylinder</p>  |
| <p>6.325.0.115.064.4</p>   | <p>A = 9,75<br/>B = 9,0<br/>C = 4,5<br/>D = 4,5<br/>L = 20°<br/>Q = 40°</p>                                 |   |

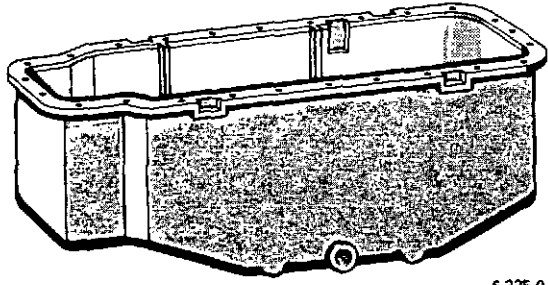
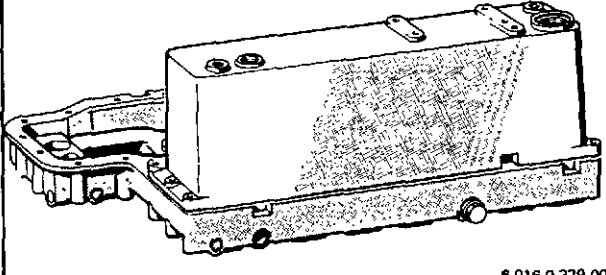
|   |  |   |
|---|--|---|
| <p>6.306.0.115.004.7    6.327.0.115.004.7<br/>6.308.0.115.014.7    6.327.0.115.014.7</p>  <p>6.306.0.329.001.5</p> | <p>dm<sup>3</sup> (litr.)</p> <p>A = 7,0<br/>B = 6,25<br/>C = 4,0<br/>D = 2,25<br/>L = 45°<br/>Q = 45°</p> |   |
| <p>6.916.0.115.004.4<br/>6.916.0.115.034.4</p>  <p>6.916.0.329.001.5</p>   | <p>A = 10,75<br/>B = 10,0<br/>C = 6,3<br/>D = 3,7<br/>L = 35°<br/>Q = 15°</p>                              | <p>4-cylinder</p>  |
| <p>6.225.0.115.004.4</p>  <p>6.225.0.329.001.5</p>  | <p>A = 30,0<br/>B = 28,0<br/>C = 6,0<br/>D = 22,0<br/>L = -<br/>Q = -</p>                                  |   |
| <p>6.916.0.115.014.7</p>  <p>6.916.0.329.002.5</p>   | <p>A = 9,25<br/>B = 8,5<br/>C = 4,0<br/>D = 4,5<br/>L = 45°<br/>Q = 45°</p>                                |   |

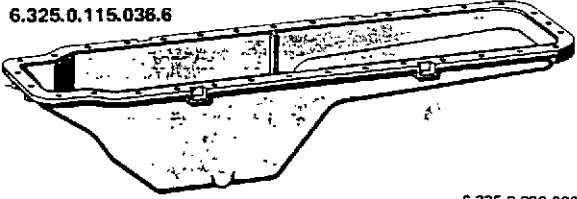
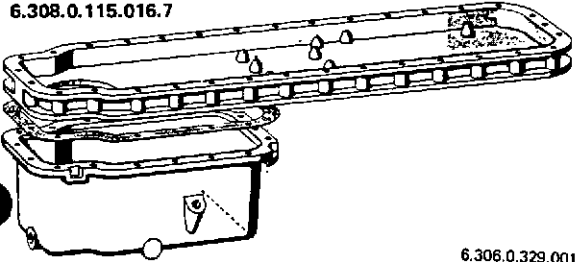
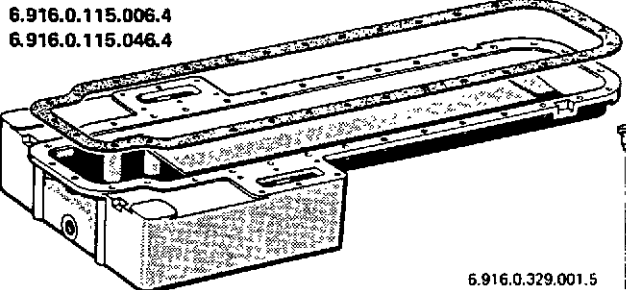
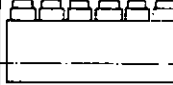
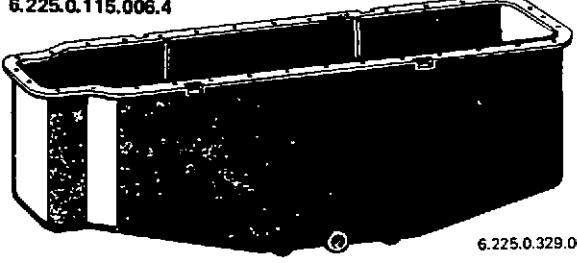
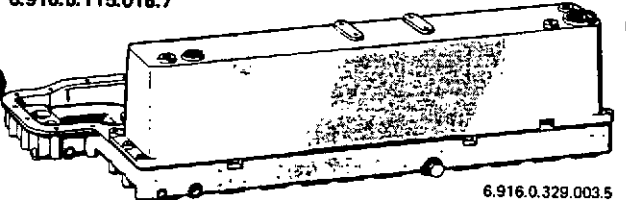
|   |   |   |
|---|---|---|
| <p>6.325.0.115.056.6<br/>6.325.0.115.038.6</p>  <p>6.325.0.329.002.4</p> | <p>dm<sup>3</sup> (ltr.)</p> <p>A = 14,0<br/>B = 13,0<br/>C = 7,0<br/>D = 6,0<br/>L = 20°<br/>Q = 45°</p> |   |
| <p>6.306.0.115.006.7<br/>6.308.0.115.016.7</p>  <p>6.306.0.329.001.5</p> | <p>A = 9,0<br/>B = 8,0<br/>C = 4,75<br/>D = 3,25<br/>L = 45°<br/>Q = 45°</p>                              |   |
| <p>6.916.0.115.006.4<br/>6.916.0.115.046.4</p>  <p>6.916.0.329.001.5</p> | <p>A = 11,5<br/>B = 10,5<br/>C = 6,3<br/>D = 4,2<br/>L = 35°<br/>Q = 15°</p>                              | <p>6-cylinder</p>  |
| <p>6.225.0.115.006.4</p>  <p>6.225.0.329.001.5</p>                      | <p>A = 44,0<br/>B = 42,0<br/>C = 9,0<br/>D = 33,0<br/>L = -<br/>Q = -</p>                                 |   |
| <p>6.916.0.115.016.7</p>  <p>6.916.0.329.003.5</p>                     | <p>A = 13,0<br/>B = 12,0<br/>C = 6,0<br/>D = 6,0<br/>L = 45°<br/>Q = 45°</p>                              |   |

### 3. Internal Engine Construction

#### 3.1 Operating Principle

The following processes, which are common to all 4-stroke diesel engines, take place in the cylinders as the pistons reciprocate.

The inlet valve is opened during the induction stroke. The piston descends, inducing air into the cylinder.

This air is compressed and heated by the subsequent compression stroke.

Just before the piston reaches top dead centre (TDC) the injection pump forces fuel through the injector into the hot air, causing ignition and combustion to take place.

The pressure in the cylinder chamber rises and drives the piston down for the power stroke. The connecting rod transmits the force to the rotating crankshaft

As the piston rises again, the burnt gases are discharged through the open exhaust valve and silencer to atmosphere.

This upward stroke is followed by the next induction stroke and the same process is repeated all over again.

The energy stored in the flywheel serves to keep the engine turning steadily.

## 3.2 Engine – Side-sectional View

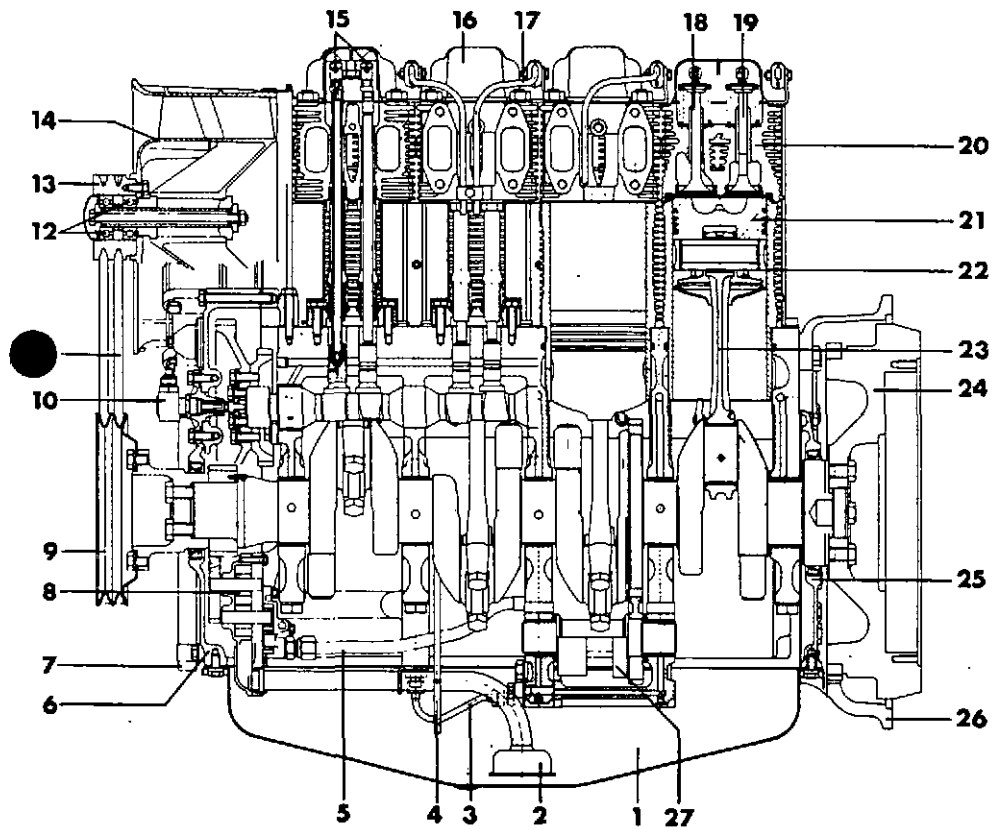

- |                                     |                             |
|-------------------------------------|-----------------------------|
| 1 Oil sump                          | 15 Rocker arm               |
| 2 Lube oil suction line             | 16 Cylinder head cover      |
| 3 Lube oil line to balance weight   | 17 Fuel delivery line       |
| 4 Oil dipstick                      | 18 Inlet valve cone         |
| 5 Lube oil delivery line            | 19 Exhaust valve cone       |
| 6 End cover (timing gear end)       | 20 Cylinder head            |
| 7 Engine vent pipe                  | 21 Piston                   |
| 8 Oil pump                          | 22 Ribbed cylinder          |
| 9 Pulley                            | 23 Connecting rod           |
| 10 Angular gear for rev counter     | 24 Flywheel                 |
| 11 V-belt                           | 25 End cover (flywheel end) |
| 12 Deep-groove ball bearing for fan | 26 Flywheel housing         |
| 13 Pulley for fan                   | 27 Balance weight           |
| 14 Fan                              |                             |

### 3.2 Engine - End-sectional View

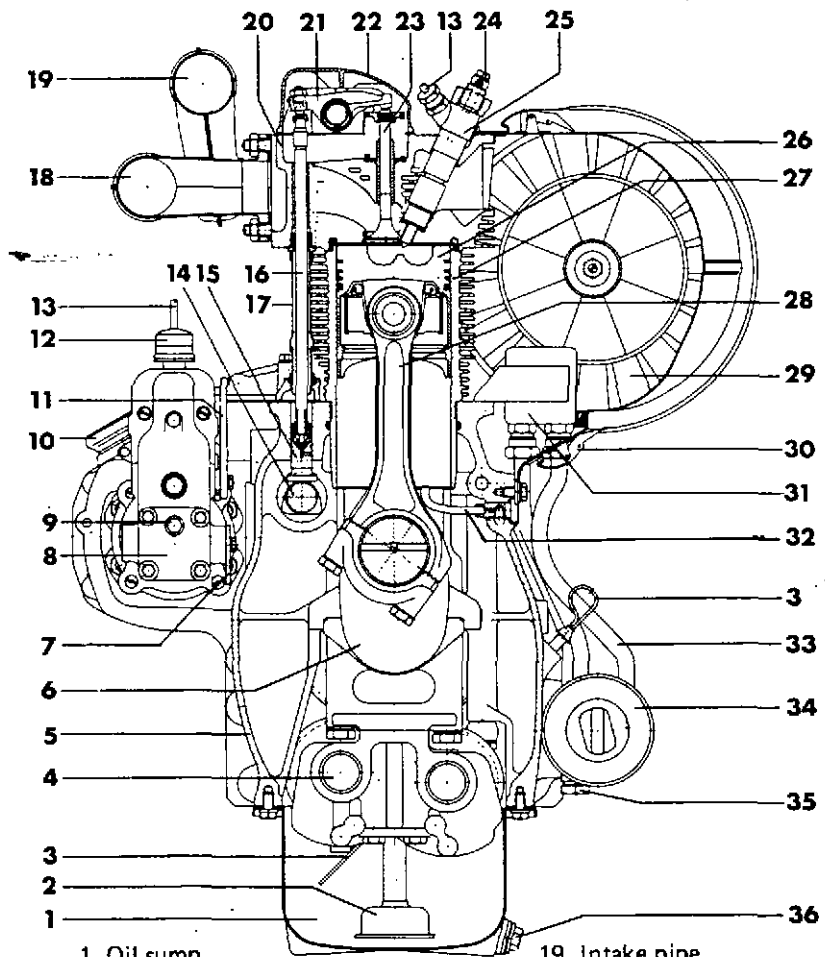

- |   |  |
|---|--|
| 1 Oil sump                              | 19 Intake pipe                         |
| 2 Lube oil suction line                 | 20 Cylinder head                       |
| 3 Oil dipstick                          | 21 Rocker arm                          |
| 4 Balance weight                        | 22 Cylinder head cover                 |
| 5 Crankcase                             | 23 Inlet/exhaust valve                 |
| 6 Crankshaft                            | 24 Leak-off line                       |
| 7 Stopping lever                        | 25 Injector                            |
| 8 Injection pump and governor           | 26 Piston                              |
| 9 Oil inspection plug in injection pump | 27 Ribbed cylinder                     |
| 10 Oil filler plug                      | 28 Connecting rod                      |
| 11 Speed control lever                  | 29 Fan                                 |
| 12 Venting filter                       | 30 Snap fastener for air ducting       |
| 13 Fuel delivery line                   | 31 Oil cooler                          |
| 14 Camshaft                             | 32 Injection nozzle for piston cooling |
| 15 Tappet                               | 33 Lube oil line                       |
| 16 Pushrod                              | 34 Exchangeable filter                 |
| 17 Pushrod cover                        | 35 Safety valve in oil cycle           |
| 18 Exhaust pipe                         | 36 Oil drain plug                      |

### 3.3 Fuel System

The fuel (diesel oil) is drawn up by the fuel pump and forced through the fuel filter to the injection pump which is driven by the camshaft. The fuel is pumped to the injector and is injected into the combustion chamber at high pressure just before top dead center. It is then mixed intimately with the compressed air and ignited.

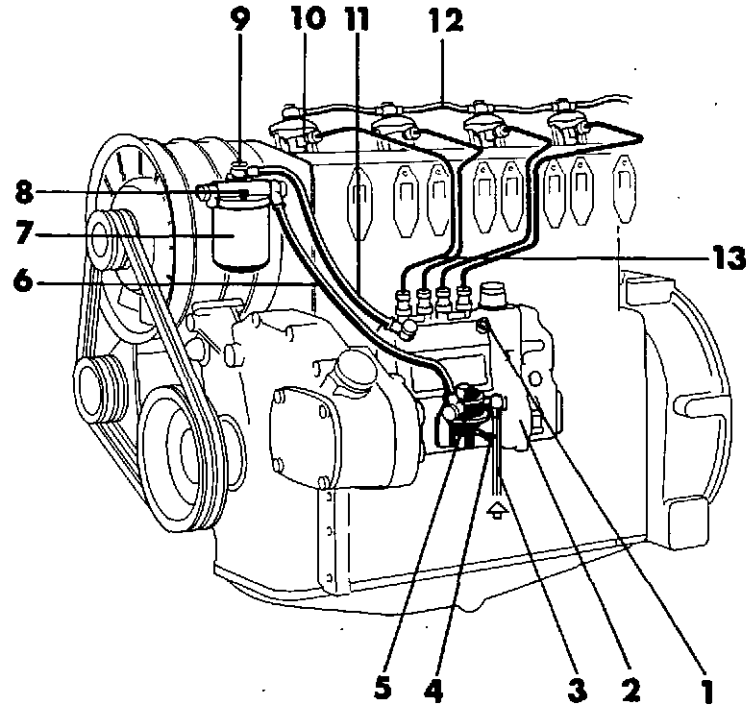

- |   |  |
|---|--|
| 1 Vent plug on injection pump                   | 8 Vent plug on fuel filter                         |
| 2 Injection pump and governor                   | 9 Bypass valve for attachment of plunger feed pump |
| 3 Fuel suction line from fuel tank to feed pump | 10 Injector  |
| 4 Priming lever                                 | 11 Fuel line from fuel filter to injection pump    |
| 5 Diaphragm fuel pump                           | 12 Leak-off line to fuel tank                      |
| 6 Fuel line from feed pump to fuel filter       | 13 Fuel delivery lines                             |
| 7 Fuel filter                                   |  |

### 3.4 Governor

Fluctuations occur at a fixed speed setting when the engine load fluctuates.

This process changes the centrifugal forces acting on the governor and governor springs, hence producing an adjusting motion.

The governor lever transmits this motion to the injection pump control rod, fuel delivery is adjusted to the changing load and the speed is kept constant within given limits.

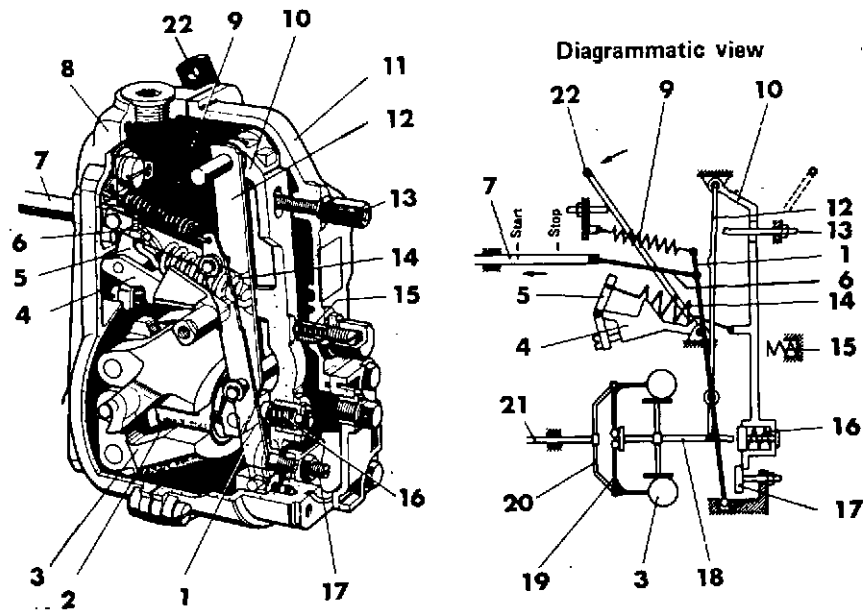

- |                              |  |
|------------------------------|--|
| 1 Governor lever             | 13 Adjusting screw for stop or idle position |
| 2 Guide bush                 | 14 Governor spring                           |
| 3 Flyweight                  | 15 Additional spring for idle speed          |
| 4 Swivel lever               | 16 Adjusting spring                          |
| 5 Rocker                     | 17 Full-load stop (delivery)                 |
| 6 Plate                      | 18 Adjusting pin and guide bush              |
| 7 Injection pump control rod | 19 Bell-crank lever on governor weight       |
| 8 Governor body              | 20 Governor hub                              |
| 9 Start spring               | 21 Camshaft                                  |
| 10 Tension lever             | 22 Adjusting lever                           |
| 11 Governor cover            |  |
| 12 Guide lever               |  |

### 3.5 Lubrication System

Each moving part of the engine is lubricated by forced-feed or splashing, depending on the particular requirements of each individual lubricating point.

The lubricating oil draws the heat out of bearings, pistons and cylinder walls. The illustration below shows the lubricating cycle.

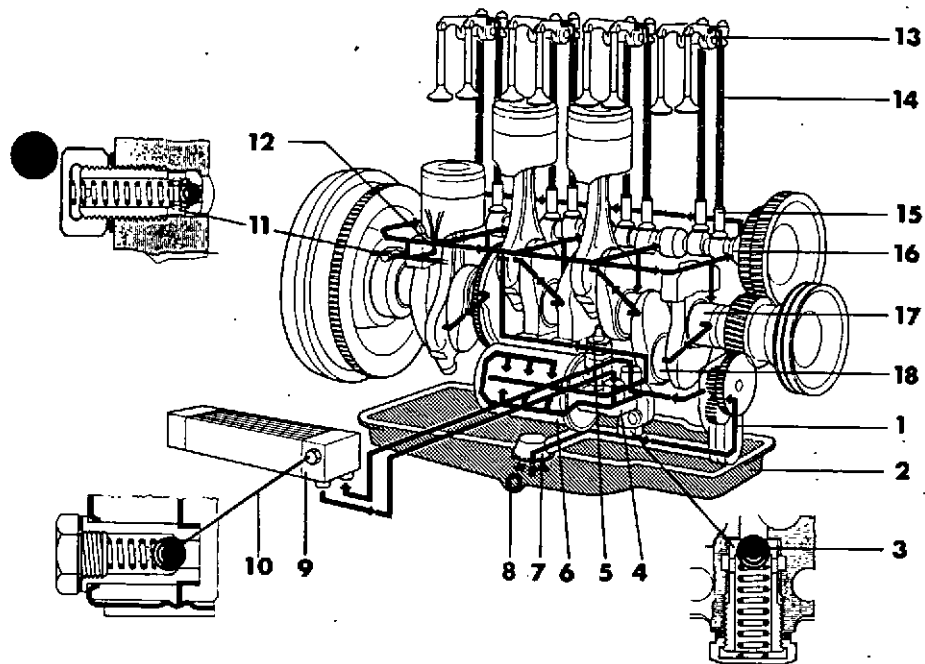

- |  |   |
|--|---|
| 1 Lube oil pump  | 10 Bypass valve in oil cooler (opening pressure 2,5 bar)        |
| 2 Oil sump   | 11 Pressure valve for piston cooling (opening pressure 1,5 bar) |
| 3 Safety valve in filter head (opening pressure 4,5 - 7,5 bar) | 12 Injection nozzle   |
| 4 Filter head  | 13 Rocker arm   |
| 5 Oil pressure switch (pressure gauge connection)              | 14 Pushrod (hollow)   |
| 6 Exchangeable lube oil filter                                 | 15 Tappet   |
| 7 Suction pipe   | 16 Camshaft   |
| 8 Oil drain plug   | 17 Crankshaft   |
| 9 Oil cooler   | 18 Crankpin   |

### 3.6 Air Cooling

The heat generated by the engine cannot be fully converted into mechanical work. Part of the residual heat is dissipated by the cooling system, the axial fan forcing the cool air into the cooling duct, through the oil cooler and across the ribs on the cylinder heads and cylinders.

When installing the engine, make sure that the hot exhaust air will not be held back anywhere. For a thermal short-circuit will otherwise form, trapping the incoming air and making the engine overheat.

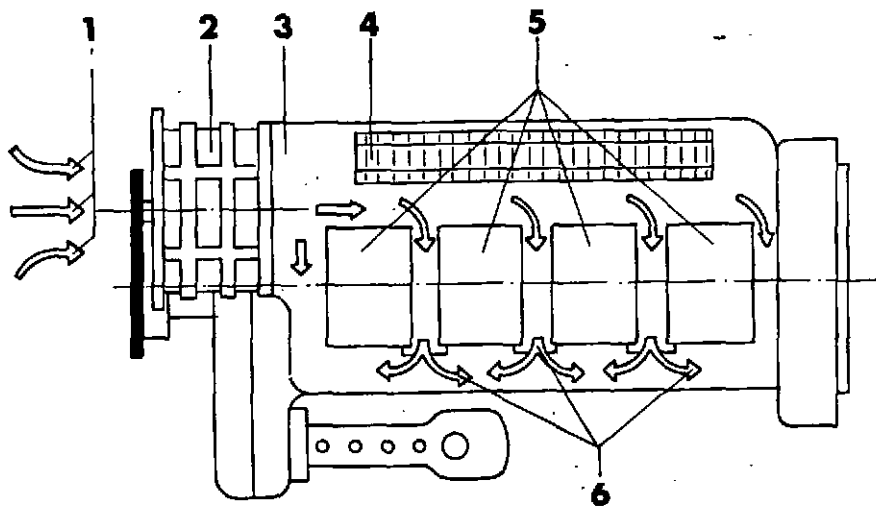

1 Incoming air  
2 Axial fan  
3 Air ducting

4 Oil cooler  
5 Ribbed cylinders and cylinder heads  
6 Exhaust air

### 3.7 Circuit Diagram

An engine with an electric starter needs a generator to charge the battery. When the starting circuit is closed, the battery feeds the starter, making the starter pinion engage the ring gear on the flywheel. The circuit diagram shows the necessary connections by way of example.

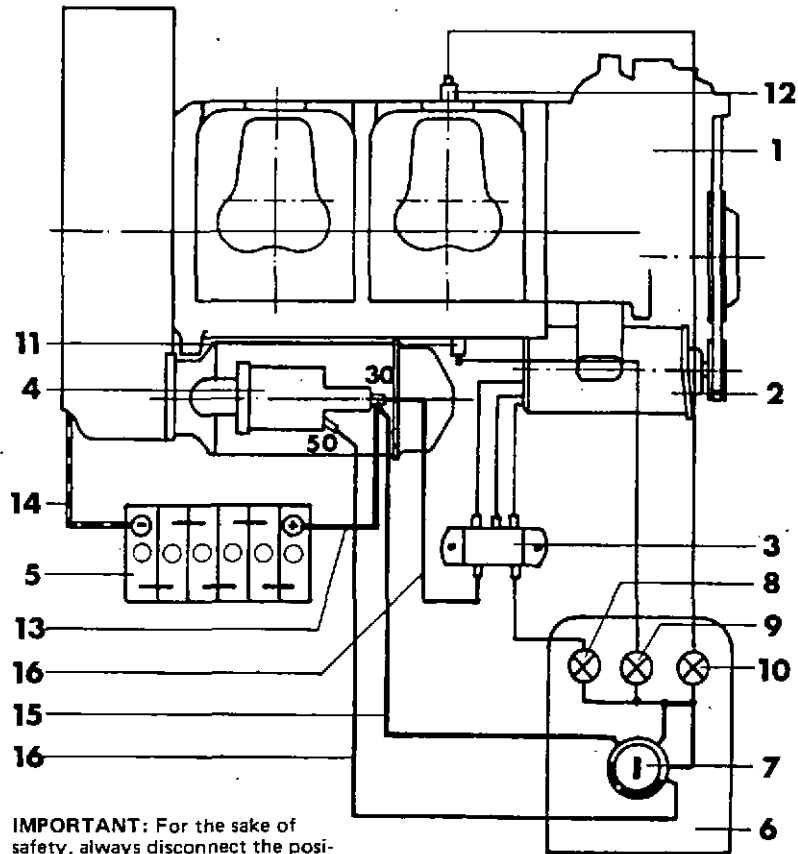

**IMPORTANT:** For the sake of safety, always disconnect the positive cable from the battery prior to starting work on the engine.

- 1 Engine
- 2 Generator
- 3 Regulator cutout
- 4 Starter
- 5 Battery
- 6 Control box
- 7 Ignition switch
- 8 Charging tell-tale
- 9 Oil pressure tell-tale

- 10 Temperature tell-tale
  - 11 Oil pressure pickup
  - 12 Temperature pickup
  - 13 Cable 50 mm<sup>2</sup>
  - 14 Earth cable
  - 15 Cable 4 mm<sup>2</sup>
  - 16 Cable 2,5 mm<sup>2</sup>
- All other cables have cross-section NYAF 1,5 mm<sup>2</sup>

#### 4. Putting into Service and Operating

**IMPORTANT:** Do not put the engine into service until it has been fastened down at its place of operation.

Operation in closed rooms necessitates adequate ventilation.

Exhaust pipe is to discharge to atmosphere.

Please read the following instructions prior to putting the engine into operation for the first time:

- 4.1 Filling up with oil
- 4.2 Venting fuel system
- 4.3 Starting
- 4.4 Adjusting speed
- 4.5 Stopping engine

These items will now be described in detail, a separate maintenance chart on page 21 being provided for routine operation.

#### 4.1 Filling up with Oil

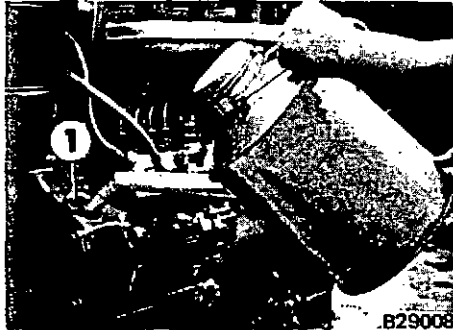

B29008

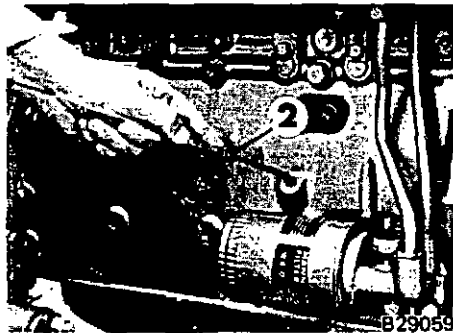

B29059

##### Sequence:

1. Tighten oil drain plug.
2. Open oil filler plug 1.
3. Fill with engine oil (see pages 4 to 7 for correct quantity).  
Always use API "CC" or "CD" proprietary oils observing the following grades:

Oil grade at corresponding ambient temperature

SAE 10W below 0°C

SAE 30 above 0°C

SAE 20W-20 can be used at ambient temperatures from -10°C to +10°C.

Failure to observe these rules may cause inadequate oil pressure and starting difficulties.

4. Check oil level on dipstick 2, with engine standing horizontally.
  5. Put back and tighten oil filler plug 1.
- Important: Clean lubricating oil is a prime requisite.

#### 4.1.1 Oil bath air filter

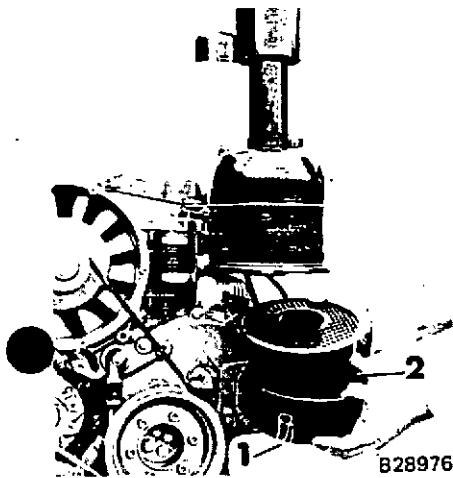

##### Sequence:

1. Release clip 1.
2. Remove bottom part 2 of filter.
3. Fill bottom part with engine oil up to line, strictly observing correct oil level.
4. Introduce element into bottom part of filter and fasten clip.

**Important:** Excessive oil quantity will cause air shortage and make the engine smoke.

#### 4.1.2 Injection pump and governor

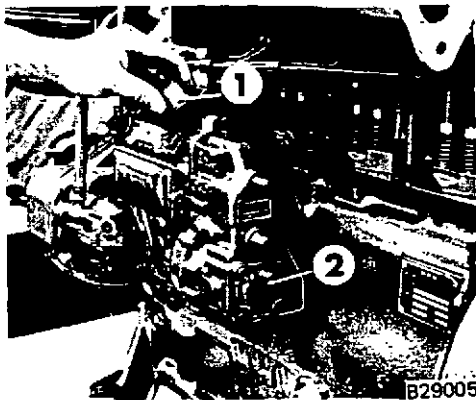

##### Sequence:

1. Unscrew venting filter 1.
2. Slacken oil level inspection plug 2 by about 2 turns.
3. Fill pump with oil until oil emerges from oil level inspection hole.
4. Screw venting filter 1 on.
5. Tighten oil level inspection plug 2.

The oil level must not go above the oil level inspection plug. The pump and governor are joined to a common passage.

## 4.2 Venting Fuel System

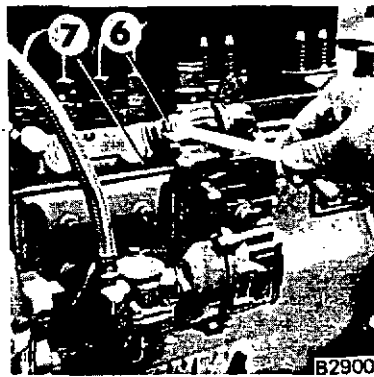
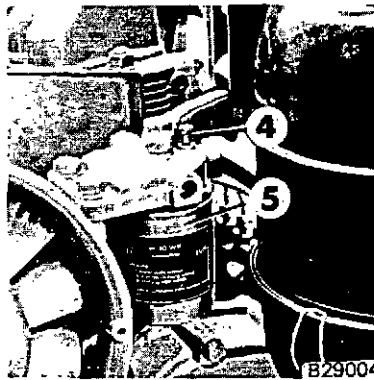
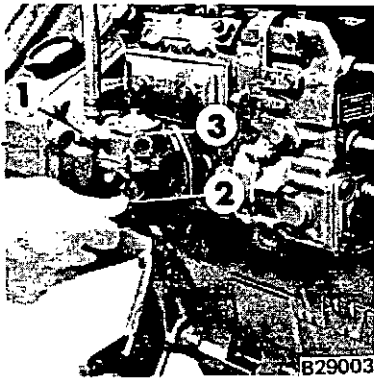

### Sequence:

1. Cleanliness is absolutely essential.
2. Pour diesel fuel into fuel tank.  
**Important:** Be sure to use proprietary fuel according to DIN 51601.
3. Slacken union screw 1 by half a turn.
4. Pump priming lever 2 on feed pump 3 until fuel emerges.
5. Tighten union screw 1.
6. Undo vent plug 4 on fuel filter 5.
7. Pump priming lever 2 until no more bubbles are left in fuel.
8. Tighten vent plug 4.
9. Undo vent plug 6 on injection pump 7.
10. Pump priming lever 2 until no more bubbles are left in fuel.
11. Tighten vent plug 6.
12. Hand-started engines:  
pump decompression lever and crank engine until fuel can be heard squirting out of the injectors. (Vent check).

## 4.3 Starting

### 4.3.1 Hand-cranking

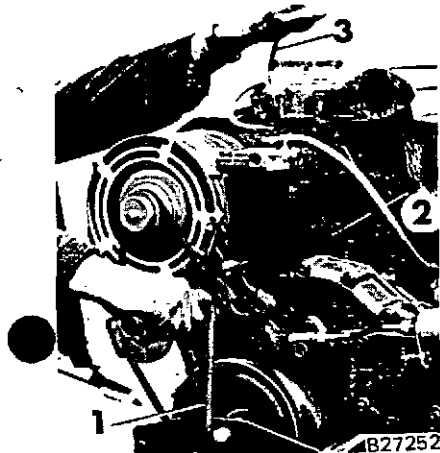

### 4.3.2 Electric starting

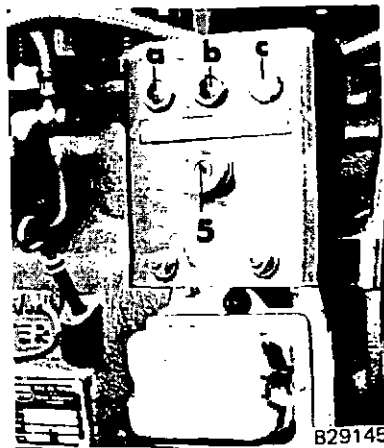

#### Sequence:

1. Fit starting crank 1.
2. Move speed control lever 2 to centre position.
3. Pump decompression lever 3 and crank engine until injector can be heard working.
4. Crank engine as fast as possible and after completing a few revolutions, release decompression lever 3 and continue to turn engine fast until it starts to fire. Repeat procedure if starting proves unsuccessful.

**Warning:** Do not push decompression lever 3 while engine is running.

1. Insert ignition key 5 and turn on.
2. Warning lights a and b turn on.
  - a = Arch charging
  - b = oil pressure tell-tale
  - c = temperature tell-tale
3. Move speed control lever to centre position.
4. Turn ignition switch clockwise, waiting for engine to start (max. 6 seconds).
5. Warning lights go out.  
(See circuit diagram 3.7, page 15).

**Important:** Allow engine to warm up before running at full load. If engine is equipped with oil pressure gauge, check directly after starting. Immediately stop engine if oil pressure is inadequate (below approx. 1 bar). (See fault table, page 29).

**Warning:** Engines equipped with alternators.

If engine has to be run without generator, disconnect cables between generator and regulator prior to starting. The practice of touching chassis to check for voltage (customary with dynamos) must be avoided on all accounts with alternators.

#### 4.4 Adjusting Speed

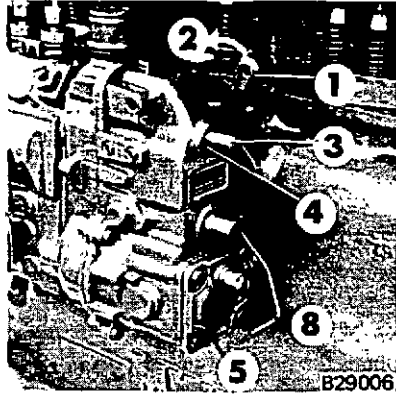

##### 4.4.1 Fine speed adjustment

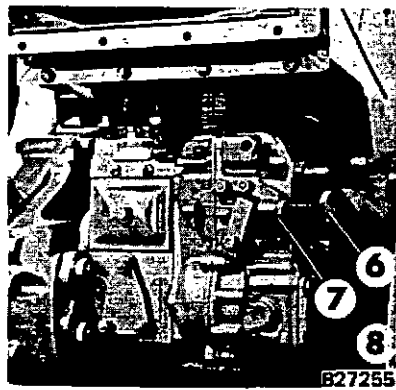

#### 4.5 Stopping Engine

see illustrations above.

#### Engines with broad speed ranges.

Turning lever 1 in direction 2 increases the engine speed. Idle speed is to be adjusted by unscrewing cap nut 3 and releasing lock-nut 4. Cover 5 has lead seal and must not be opened. Lever 1 can be actuated via linkage or a control cable.

#### Engines running at constant speed.

1. Release lock-nut 7.
2. Knurled screw 6 serves to change speed setting:
  - a) turn to right = higher speed
  - b) turn to left = lower speed

Tighten lock-nut upon completion.

#### Press stopping lever 8 downwards

A lifting magnet or separate linkage can be fitted for engine stopping.

**5. Maintenance**

**Maintenance chart**

**IMPORTANT:** Careful maintenance increases reliability, lengthens service life and saves costs.

| Maintenance intervals, engine service in |                                   | running hours |
|--|-----------------------------------|---------------|
| Daily or not later than                  | every                             | 10            |
|  | at                                | 30            |
|  | at                                | 60            |
|  | repeat every                      | 125           |
|  | repeat every                      | 250           |
|  | repeat every                      | 750           |
|  | repeat every                      | 2250          |
| <b>Maintenance operations</b>            |                                   | <b>No.</b>    |
| + = = = = = =                            | Fill fuel tank 1)                 | 5.1           |
| + = = = = = =                            | Check oil level                   | 5.2           |
| + = = = = = =                            | Check bolted joints               | 5.3           |
| + + + = = = =                            | Change oil                        | 5.4           |
| + + + = = = =                            | Check oil level in injection pump | 5.5           |
| + + + = = = =                            | Check and tighten V-belt          | 5.6           |
| + = = = = = =                            | Clean air filter 2)               | 5.7           |
| + = = = = = =                            | Clean engine breather             | 5.8           |
| + = = = = = =                            | Check battery                     | 5.9           |
| + = = = = = =                            | Adjust valve clearance            | 5.10          |
| + = = = = = =                            | Clean cooling ribs and fan 2)     | 5.11          |
| + = = = = = =                            | Exchange fuel filter              | 5.12          |
| + = = = = = =                            | Check injectors                   | 5.13          |
| + = = = = = =                            | Change oil at injection pump      | 5.14          |
| + = = = = = =                            | Check compression pressure        | 5.15          |
| + = = = = = =                            | Check blower bearings             | 5.16          |
| as required                              | Protect engine                    | 5.17          |

These numbers indicate the sections where the maintenance operations are described in detail.

1) earlier if demanded by engine duty 2) earlier if demanded by dusty conditions

At average daily engine service of

2 4 6 10 12 16 20 24 running hours

the above maintenance intervals will be reached after:

|    |    |     |      |      |      |      |      |      |
|----|----|-----|------|------|------|------|------|------|
| 2W | 1W | 5D  | 3D   | 2,5D | 2D   | 1,5D | 1D   | 30   |
| 4W | 2W | 10D | 1W   | 5D   | 4D   | 3D   | 2,5D | 60   |
| 2M | 1M | 3W  | 2W   | 10D  | 8D   | 1W   | 5D   | 125  |
| 1Y | 6M | 4M  | 2,5M | 2M   | 7W   | 1M   | 3W   | 750  |
|    |    | 1Y  | 7M   | 6M   | 4,5M | 4M   | 3M   | 2250 |

D = Days

W = Weeks

M = Months

Y = Years

### 5.1 Filling Fuel Tank

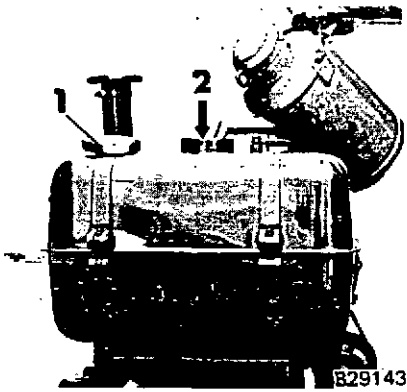

#### Sequence:

1. Observe cleanliness.
2. Place diesel fuel (proprietary grade only) in readiness for filling tank.
3. Open fuel tank cap 1.
4. Fill tank without removing strainer.
5. Clean strainer 2 if necessary.
6. Close fuel tank cap.

Venting: see 4.2 (page 18) if fuel tank is run dry.

### 5.2 Checking Oil Level

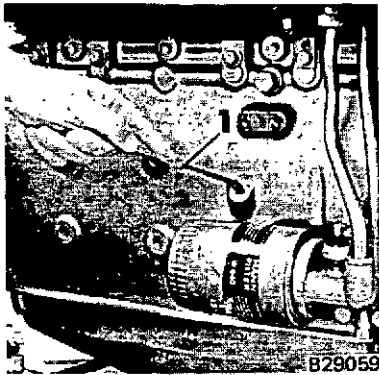

1. Stop engine, waiting a few minutes.
2. Pull out oil dipstick 1 and wipe with clean rag or soft paper.
3. Put dipstick back, pushing fully home.
4. Withdraw dipstick, checking oil level.
5. Top up if necessary, yet not above top mark. To top up, always use same oil grade as that in engine.

**WARNING:** Never run engine at inadequate oil level.

### 5.3 Checking Bolted Joints

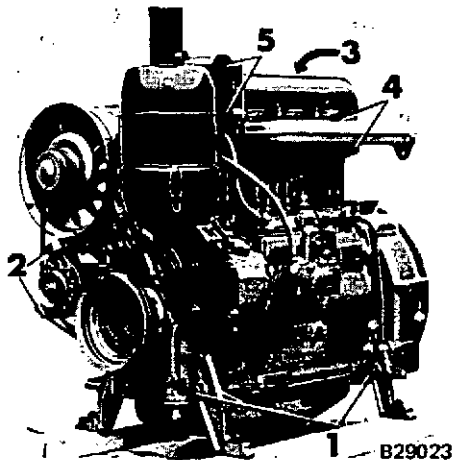

#### Bolted joints

|                            |   |
|----------------------------|---|
| on engine mounting         | 1 |
| on generator               | 2 |
| on injectors               | 3 |
| on intake and exhaust pipe | 4 |
| on air filter              | 5 |

and all other bolted joints.

Check for tightness and re-torque if necessary.

**Important:** Cylinder head bolts must always be tightened by workshop personnel (torque wrench).

### 5.4 Changing Oil

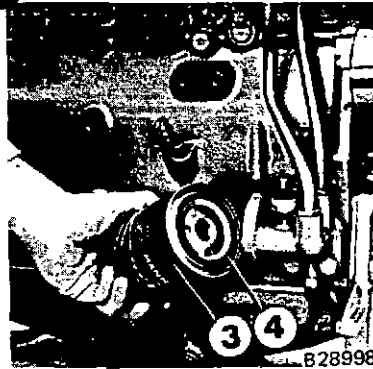
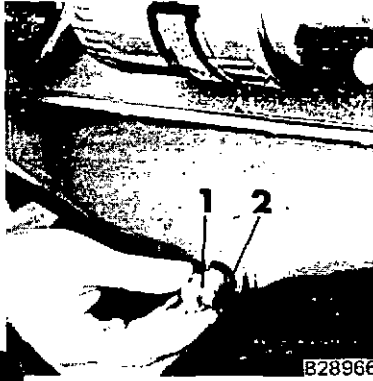

#### Sequence:

1. Warm up engine and then stop.
2. Place oil can beneath engine.
3. Remove oil drain plug 1.
4. Wait until all oil has run out.
5. Put oil drain plug back (note gasket 2) and tighten.
6. Fill with oil, referring to 4.1 (page 16).

#### Important:

1. Oil filter is to be unscrewed (turn anti-clockwise) and exchanged at every second oil change after oil is drained off.
2. Moisten rubber seal 4 with oil prior to screwing new filter on.
3. Finally run engine to check for leakage.

### 5.5 Checking Oil Level in Injection Pump



#### Sequence:

1. Slacken oil level inspection plug 1 by about 2 turns. Drain excess oil/fuel mixture.
2. Unscrew vent filter 2.
3. Fill with new engine oil until clean oil runs out of oil level inspection hole.
4. Screw vent filter 2 back on.
5. Tighten oil level inspection plug 1.

The oil level must not be higher than oil level inspection plug 1.

### 5.6 Checking and Tightening V-belt

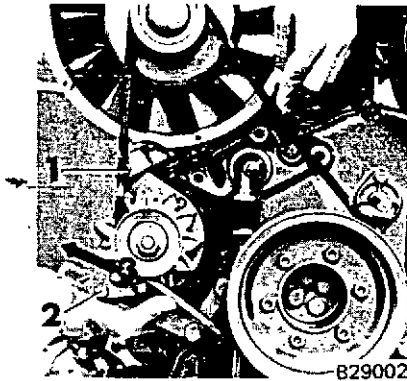

#### Checking V-belt

V-belt must not give more than 10 - 15 mm under your thumb. Otherwise tighten V-belt.

#### Sequence:

1. Release hex-head bolts 1 and 2.
2. Draw generator 3 outwards.
3. Tighten hex-head bolts 1 and 2.
4. Check V-belt tension with your thumb.

### 5.7 Cleaning Air Filter

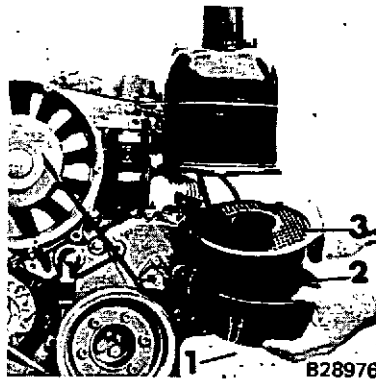

#### Sequence:

1. Open clip 1.
2. Detach filter bottom 2 with filter element 3.
3. Thoroughly rinse filter element 3 in diesel fuel.
4. Empty and clean filter bottom.
5. Fill filter bottom with engine oil up to line, strictly observing correct oil level.
6. Introduce filter element into filter bottom and fasten clip.

**Important:** Excessive oil quantity will cause air shortage and make engine smoke.

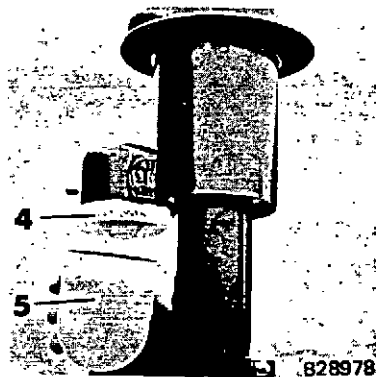

A preliminary separator 4 and dust collector 5 are used under extremely dusty conditions. The transparent collector is to be checked and cleaned every day. On no account pour oil into collector.

### 5.8 Cleaning Engine Breather

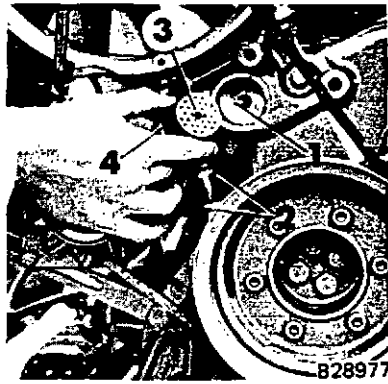

### 5.9 Checking Battery

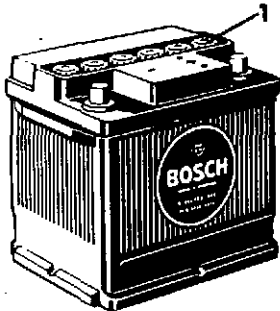

### 5.10 Adjusting Valve Clearance



#### Sequence:

1. Unscrew hexagon nut 1.
2. Release clip 2.
3. Remove breather housing 3.
4. Note O-ring 4.
5. Rinse breather housing in diesel fuel.
6. Attach breather housing, fitting new O-seal 4 if necessary.
7. Tighten clip 2.
8. Tighten hexagon nut 1.

#### Electrically started engines:

1. Measure acid density. Recharge battery if density has dropped below 1.21 kg/l (1.23 to 1.25 is normal). Charging current not to exceed 6.5 amps.
2. Open all caps 1 for charging.
3. Top up acid level (15 mm above top of plates). Always use distilled water to top up.
4. Coat terminal posts with acid-resistant grease.
5. Make sure terminals are tight.
6. Unused batteries are to be recharged every 4 to 6 weeks.
7. Do not place metal objects on battery.

1. Unscrew cylinder head covers, noting gaskets.
2. Set each cylinder individually to TDC = 1/4 - 1/2 turn after inlet valve closes. 1)
3. Check clearance, inserting 0.2 mm feeler gauge 1 between rocker arm and valve stem end.  
If necessary:
4. Release lock-nut 2.
5. Release adjusting screw 3.
6. Adjust clearance at adjusting screw.
7. Tighten lock-nut 2.
8. Check clearance again, using feeler gauge.
9. Fit and tighten cylinder head covers. Note gaskets.

1) IMPORTANT: To avoid unnecessary turning of the crankshaft, set the valves in the same sequence as the firing order (see page 2).

### 5.11 Cleaning Cooling Ribs and Fan

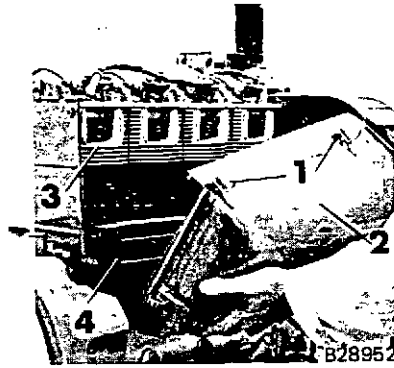

#### Sequence:

1. Open clips 1.
2. Remove air ducting 2.
3. Carefully wash cooling ribs 3 and oil cooler 4 with diesel oil, or blow out using compressed air.
4. Attach air ducting.
5. Close clips.

The maintenance intervals for cleaning the cooling ribs must match the prevailing dust conditions.

### 5.12 Exchanging Fuel Filter

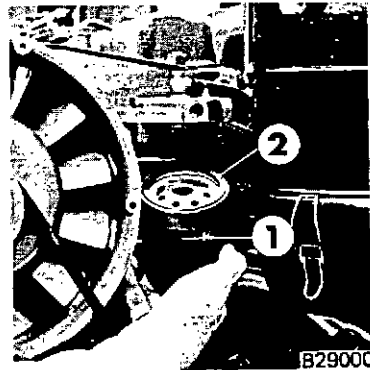

#### Sequence:

1. Close fuel tap.
2. Unscrew fuel filter 1, turning anti-clockwise.
3. Moisten rubber seal 2 with oil prior to screwing new filter on.
4. Screw new fuel filter on hand-tight.
5. Open fuel tap.
6. Vent fuel system (see 4.2, page 18)
7. Check fuel filter for leakage.

### 5.13 Checking Injectors



#### Sequence:

1. Remove injectors and connect to tester. **Workshop.**
2. Operate pump lever.
3. Injection pressure must be 180 bar, fuel being atomized at 4 holes.
4. Should this value not be reached, nozzle or entire injector will have to be exchanged or repaired by a workshop.
5. Fit and tighten injectors, making sure there is no leakage. Finally connect lines.

### 5.14 Changing Oil at Injection Pump

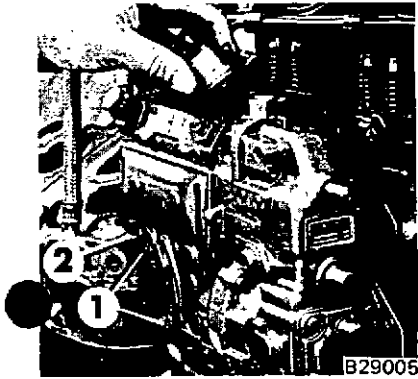

#### Sequence:

1. Place oil can beneath injection pump.
2. Unscrew hexagon nuts 1 and remove feed pump 2. Note gasket.
3. Wait until all oil has run out.
4. Screw feed pump on.
5. Fill with oil, referring to 4.1.2 on page 17.

### 5.15 Checking Compression Pressure

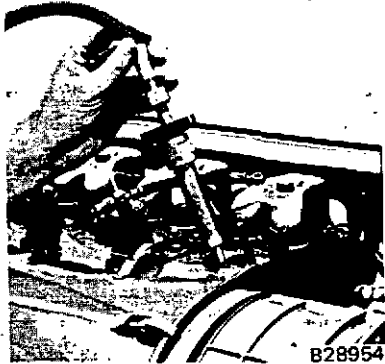

Having compression pressure checked by workshop where the necessary equipment is available.

The operation described below will help you make a coarse assessment of the compression pressure.

#### Sequence:

1. Move stopping lever to stop position.
2. Turn engine in direction of operation.
3. Resilient resistance must be felt as each piston is cranked to TDC.
4. Adjust valve clearance if engine turns too freely.
5. Consult workshop should adjustment of valve clearance prove unsuccessful.

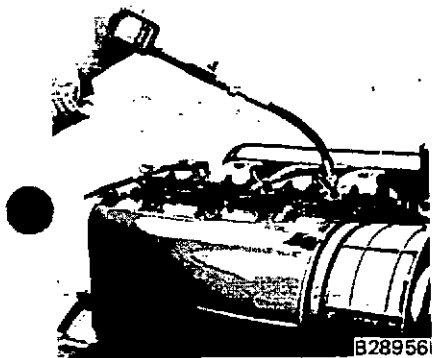

### 5.16 Checking Fan Bearings

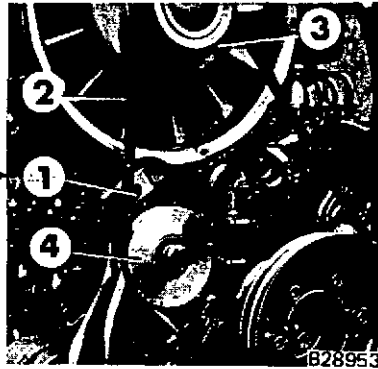

#### Sequence:

1. Release hex-head bolt 1.
2. Remove V-belt 2.
3. Turn fan wheel 3 at pulley to check for play and freedom of movement.
4. Check idler 4 for play and freedom of movement.
5. Check generator for play and freedom of movement.
6. In case of doubt, consult workshop and exchange ball bearings.

### 5.17 Protecting Engine

The engine will need protection against corrosion if it is to be left idle for a lengthy period (several weeks).

1. Drain oil sump, referring to 5.4 (page 23).
2. Drain fuel tank.
3. Mix 6 l fuel with 1 l protective oil.
4. Pour this mixture into fuel tank.
5. Fill engine with protective oil, referring to 4.1 (page 16).
6. Run engine for a few minutes.
7. Coat bare outer parts with protective grease.
8. Repeat protective treatment after 3 months.
9. On putting back into service, drain off protective oil and change oil, referring to 5.4 (page 23).

# 6. TROUBLE SHOOTING

## Faults

The causes are given successively in boxes in the order in which they will probably occur. References to remedies are given at the bottom of each box.

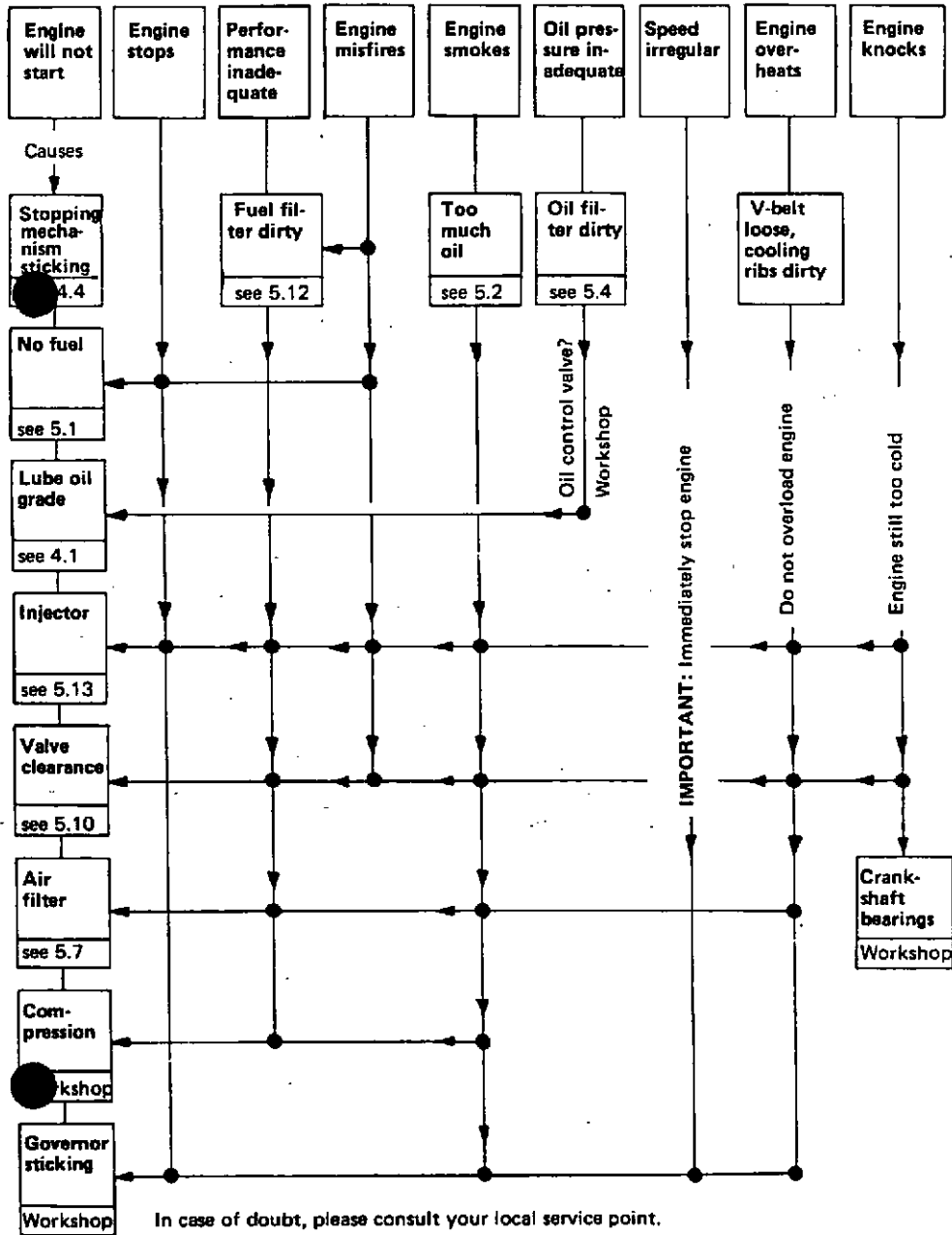

Wiring diagram for D Series engines with Motorola alternator.

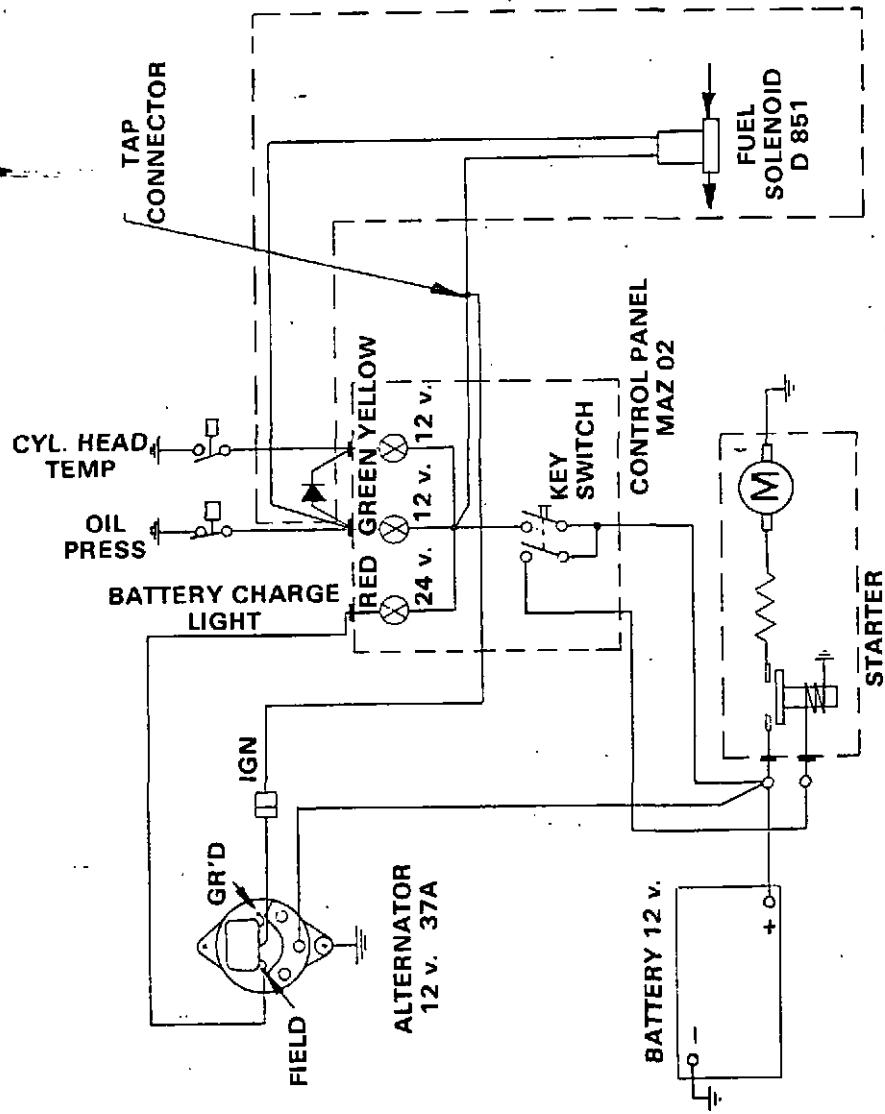

## 6.2 Tightening torque requirements

The following bolted joints can only exhibit the necessary strength capability when tightened to correct torque, it therefore being mandatory, that they be tightened in accordance with the following torque requirements.

| Item | Bolted joints   | Thread/Material                                  | Tightening torque      |                                |
|------|---|--|------------------------|--------------------------------|
|      |   |  | in daNm<br>min.        | ≈ mkp<br>max.                  |
| 1    | Cylinder head nuts •  | M12-8.8  | 4.5                    | 5.5                            |
| 2    | Bearing cover bolts   | M14-10.9   | 16<br>(13)             | 17<br>(14)*                    |
| 3    | Counterweight bolts   | (M14-10.9)                                       | (14)                   | (15)*                          |
| 4    | Flywheel fastening bolts and hub to crankshaft bolts  | M16-10.9<br>(M12x1.5-12.9)<br>(M12x1.5-10.9)     | 28.5<br>(15)<br>(12)   | 29.5<br>(15.5)*<br>(12.5)*     |
| 5    | Hub to V-belt pulley bolts  | M10-8.8  | 4.5                    | 5                              |
| 6    | Hub to vibration damper bolts   | M10-10.9   | 6.5                    | 7                              |
| 7    | Gear to camshaft bolts, camshaft and injection pump drive gear bolts  | Durlok M8-12.9<br>(M8-10.9)                      | 6<br>(3)               | 7<br>(3.5)*                    |
| 8    | Bosch injection pump shaft nuts   | M12  | 6                      | 7                              |
| 9    | Connecting rod bolts  | M12x1.5-12.9<br>(M12x1.5-10.9)                   | 9.5<br>(7.5)           | 10<br>(8)*                     |
| 10   | Flywheel housing bolts  | M12-12.9<br>M10-12.9<br>(M12-10.9)<br>(M10-10.9) | 14<br>8<br>(11)<br>(6) | 14.5<br>8.5<br>(12)*<br>(6.5)* |
| 11   | Oil pan bolts   | M8   | 2                      | 2.5                            |
| 12   | Balance weight bolts  | M10-8.8  | 3.5                    | 4                              |
| 13   | Oil pump mounting bolts   | Durlok M8-12.9                                   | 3                      | 4                              |
| 14   | Rocker bracket bolts  | M10-8.8  | 3.5                    | 4                              |
| 15   | Crankcase tie bolts   | M12  | 3                      | 4                              |
| 16   | Fuel delivery line nuts (counter movement using an open-ended spanner on the injection valve pressure connection) | M12x1.5<br>M14x1.5                               | 2<br>2                 | 2.5<br>2.5                     |

↑ The location of these bolted joints is identified by these numbers in 6.2.1

- Coat the contact surfaces of the nut, thread and tie-bolt thread with molycote, first tightening nuts fingertight then tighten down diagonally in steps to the prescribed final torque. Shut down engine after trial running 1-2 hours. Loosen bolts a quarter turn with the engine cold and retighten to prescribed torque. Check valve play.

\* Torque requirements apply to engines with 10-digit engine No., e.g. 327.62.01000.

Bracketed torque requirements apply to engines with 9-digit engine Nos., e.g. 327.6.01000.

Parts Book 42-115 and Shop Manual 42-114 are available at your Murphy Distributor.

Part numbers:

**Lube Oil Filter —**  
All Models — 438-14

**Fuel Oil Filter —**  
All Models — 438-15

**V-Belt —**  
D327-2 and D327-3  
6.0345.02.0.1175 or 434-20

**V-Belt —**  
D327-4 and D327-6  
6.0345.11.0.1250 or 434-22

When ordering parts be sure to give engine model, serial number and specifications number.