

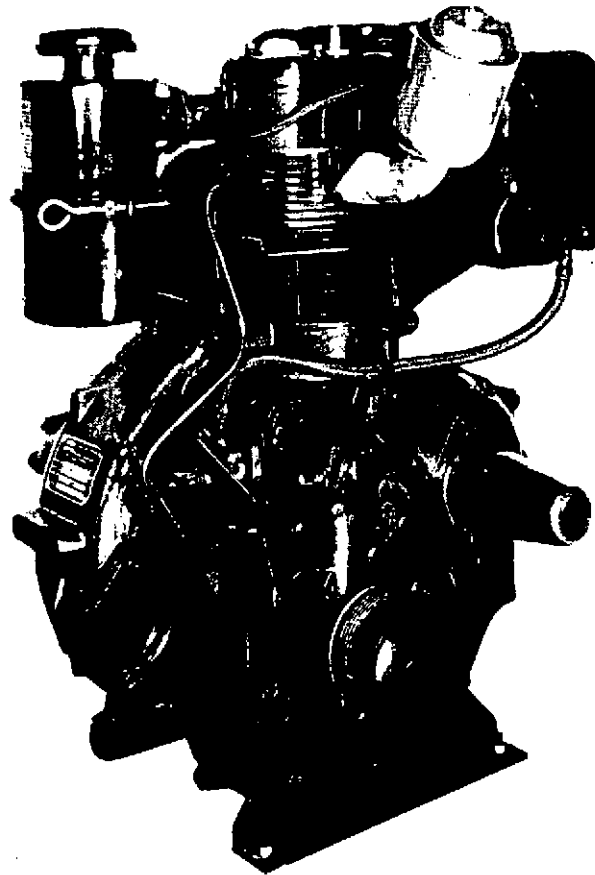

**INSTRUCTIONS FOR
OPERATION, MAINTENANCE
AND TECHNICAL INFORMATION
LKS**



OPERATING INSTRUCTIONS

LKS

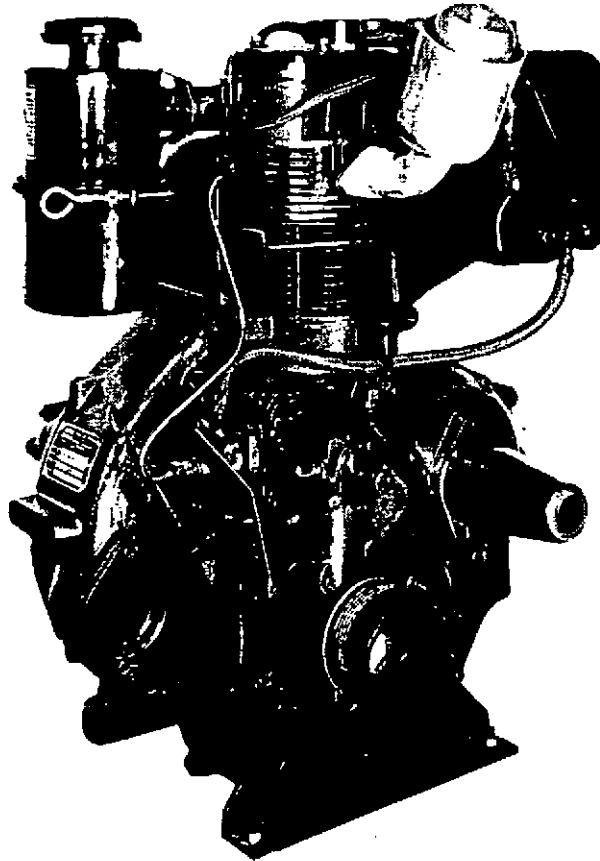

MURPHY DIESEL CO.
5317 W. Burnham St.
Milwaukee, Wisconsin 53219

INTRODUCTION

- We recommend you to read this manual carefully and closely follow the operating and maintenance instructions before you start your engine for the first time.

Always use lubricants of reputable brand which comply with our specifications.

- In order to avoid failures of the injection system, make sure that only clean fuel is used.
- Remember that the life of your engine depends on a careful and regular maintenance program.
- In case of failures, please contact us or our distributor. Give all details including engine serial number and specifications number.
- For service parts or warranty information contact your Murphy Diesel Distributor or the factory. Always include your engine serial number, model and specifications number located on the name plate.

Murphy Diesel Co.
5317 W. Burnham St.
Milwaukee, Wisconsin 53219
414-645-2255

CONTENTS

	Page
1. Technical Specifications	4-5
2. Engine description	5
2.0. Diesel engine	5
3. Lube oil circuit, cooling and fuel systems	6
3.1. Lube oil circuit	6
3.2. Cooling system	7
3.3. Fuel system	7
4. Preparations for the first start-up	8
4.1. Lube oil filling	8
4.2. Fuel filling	9
4.3. Venting the fuel system	9
5. Starting the engine	9
5.1. Before starting	9
5.2. <i>Electrical starting</i>	9
5.2.1. Cranking handle starting	10
5.3. After starting	10
5.4. Observations during operation	10
5.5. Stopping the engine	11
6. Routine maintenance of the engine	11
7. Maintenance Guide	12
7.1. Venting the fuel system	12
7.2. Venting the injection pump	12
7.3. Fuel filter	13
7.4. Oil filter maintenance	13
7.5. Valves clearance adjustment	13
8. Trouble-shooting	14
8.0. Causes and actions to be taken	14
9. Running material and preservation	16
9.1. Diesel Fuel	16
9.2. Preservation of stored engines	17
9.3. Air filter	17
Maintenance schedule	18
Wiring diagram	19
Notes	20

LKS TECHNICAL SPECIFICATIONS

1. General Description	
Model	LKS
Number of Cylinders	One
Combustion	Direct injection
Combustion cycle	Four stroke
Cooling system	Air cooled
Bore	85 mm.
Stroke	100 mm.
Lubrication	Force-feed-gear (type oil pump)
2. Fuel Injection System	
Injection pump	IESA
Injector	IESA
Commencement of delivery	27 + 1° BTDC
Injection pressure	180 + 0.5 kg/cm ²
Injection pump pre-stroke	2.3 - 2.5 mm.
NOTE: 0.1 mm. more pre-stroke gives a point of 1° delay.	
Fuel consumption maximum	200 gr/C.V. hr.
3. Cylinder Head	
Valve clearance — engine cold	0.2 mm.
Valve projection	1.15 - 1.3 mm.
Valve angle	45°
4. Cylinder	
Compression height	A = 0.8 - 1.1 mm.
Adjustable by shims	0.1 mm., 0.2 mm.

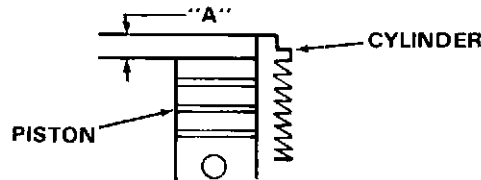

Clearance volume	25.3 ± 0.5 cm ³	
5. Crankshaft		
Front main journal diameter	54.9402 mm.	
Rear main journal diameter - std.	60.0024 mm.	
Connecting rod journal diameter - std.	39.9669 mm.	
Repair stage I	39.709 - 39.725 mm.	
Repair stage II	39.459 - 39.475 mm.	
Repair stage III	39.209 - 39.225 mm.	
Repair stage IV	38.959 - 38.975 mm.	
Crankshaft roller bearing ID	60 - 0.015 mm.	
Rear bearing spacer ID	72.5 + 0.2 mm.	
Backlash - Crankshaft and Camshaft gear	0.11 - 0.27 mm.	
Swept volume	567.45 cm ³	
6. Cam Timing		
Intake	OPEN 1° BTDC	CLOSED 36° ABDC
Exhaust	36° BBDC	1° ATDC
Acceptable Tolerance ± 3°		

7. Bearing Clearance		RADIAL	AXIAL
Crankshaft bearing		0.05 - 0.14 mm.	0.10 - 0.22 mm.
Main cam bearing		0.03 - 0.07 mm.	0.9 - 0.10 mm.
Connecting rod bearing		0.05 - 0.08 mm.	0.30 - 0.50 mm.
Piston pin bushing		0.04 - 0.06 mm.	N/A
8. Lubrication System			
Type of oil		API classified CC or CD	
Ambient temperatures		below 5° C SAE HD 10	
		-5° to + 10° C SAE HD 20	
		+10° to + 30° C SAE HD 30	
		over + 30° C SAE HD 40	
Oil capacity		1.3 liters	
Lube oil consumption		1.5 gr/C.V. hr.	
Oil pressure - running		3 - 4 kg/cm ²	
Oil pressure - minimum idle		0.5 - 0.8 kg/cm ²	
9. Torque Data		MKP	
Connecting rod bolts		3 + 0.5	
Crankshaft counterweight bolts ...		8.5 + 1	
Flywheel bolts		9.0 + 0.5	
Cylinder head nuts		5.0 + 0.5	
Injection pump pressure pipe		4.0 + 1	
Rocker arm bracket bolt		1.0 + 0.5	
Cranking nut		20.0 + 1	
Cylinder head cover - bolt		1.5 + 0.5	
Cylinder head stud in crankcase ...		3.0 + 1	
Crankshaft bearing			
fastening bolt		1.5 + 0.5	
Bearing housing fastening nut		1.5 + 0.5	
Lube oil pump fastening bolt		1.5 + 0.5	

2. ENGINE DESCRIPTION

2.0. Diesel engine

- LKS is an air cooled four-stroke Diesel engine.
- It works according to the direct injection principle. Most important advantages of this combustion method are:
 - A high specific output
 - Low thermal stress
 - Good cold starting properties
 - Low fuel consumption.
- Originally designed for stationary and moving appliances is also suitable for a large range of vehicles and machinery.
- Consult your Distributor. A lot of accessories such as: electrical starting, clutches pulleys, gear reducers, etc. are available to fit your particular needs.

3. LUBE OIL CIRCUIT, COOLING AND COMBUSTION SYSTEMS

3.1. Lube oil circuit

Depending on the particular bearing surface of the moving parts, a force feed or splash lubrication is provided. Lube oil pump aspirates the oil from deepest point of the oilpan and delivers it through a micro-filter to the following bearings:

Main and connecting rod bearings,
Rocker arm bearings,
Camshaft bearings.

Oil coming out from connecting rod bearings is then splashed to piston and cylinder liner.

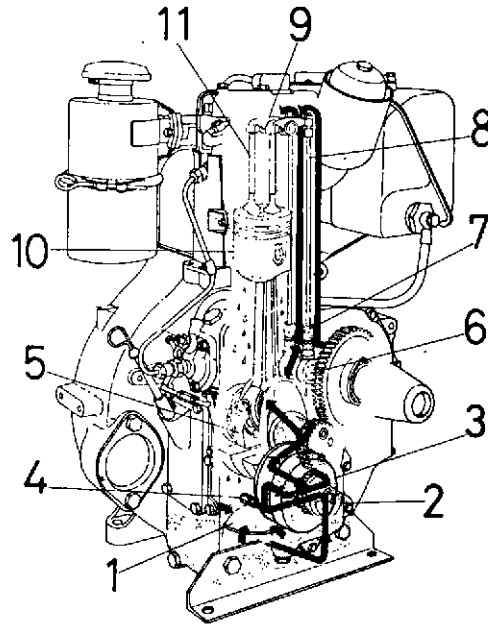

- | | |
|-----------------|-----------------|
| 1. Intake | 7. Valve tappet |
| 2. Oil pump | 8. Push rod |
| 3. Oil filter | 9. Rocker arm |
| 4. Safety valve | 10. Piston |
| 5. Crankshaft | 11. Valves |
| 6. Camshaft | |

3.2. Cooling system

Cylinder and cylinder head are cooled by the air from the flywheel acting as a fan.

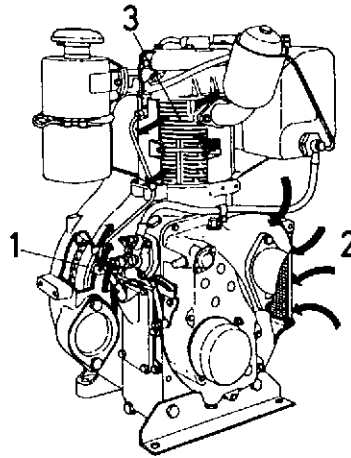

1. Flywheel fan
2. Air inlet
3. Air outlet

3.3. Fuel system

Fuel is taken from the tank through the fuel filter to the injection pump which delivers it under high pressure to the injection valve. Leak off fuel from the injection valve flows back to the tank.

1. Fuel tank
2. Fuel filter
3. Fuel pipe from filter to injection pump
4. Injection pump
5. Fuel delivery pipe
6. Injector
7. Leak off pipe to tank

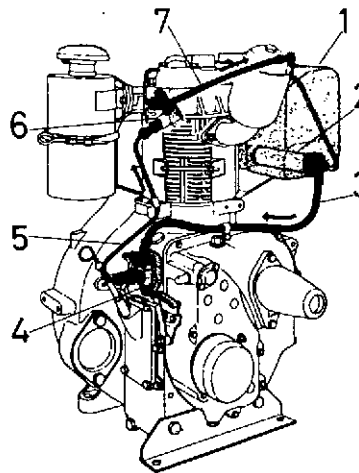

ALWAYS USE REPUTABLE FUEL

4. PREPARATIONS FOR THE FIRST START-UP

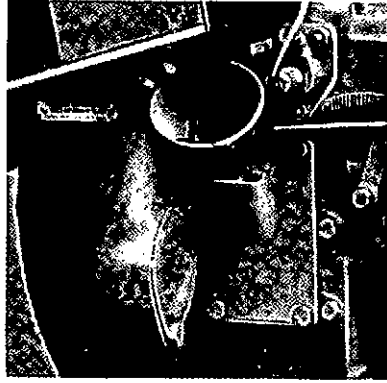

Picture 1

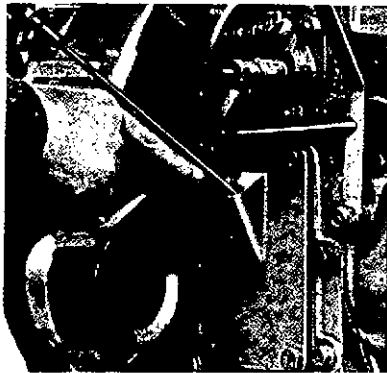

Picture 2

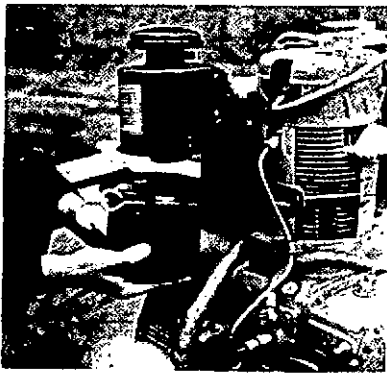

Picture 3

4.1. Lube oil filling

a) **Engine.** Unscrew filler plug and fill in with API classified CC or CD oil depending on ambient temperature as follows:

below -5°C : **SAE HD 10**
from -5° to $+10^{\circ}\text{C}$: **SAE HD 20**
from $+10^{\circ}$ to $+30^{\circ}\text{C}$: **SAE HD 30**
over $+30^{\circ}\text{C}$: **SAE HD 40**

To avoid damages by lubricants of inferior quality it is recommended to use only reputable brands and to keep using the brand originally chosen.

Unsuitable oil or delayed oil changes will cause troubles and higher repair costs.

b) **Oil level.** Check oil level in sump (picture 2).

When engine is in horizontal position, oil level should reach upper mark on the dipstick.

NOTE!!

Too high oil level will cause high oil consumption and carbon formations

Too low a level will cause damage to the engine.

c) **Oil bath air filter.** Fill to mark with clean engine oil.

Renew oil if it becomes thick and dark or overcomes upper mark on dipstick.

NEVER operate your engine with the air filter removed as dust will enter the cylinder causing premature failure of the engine.

4.2. Fuel filling

Fuel used is diesel fuel #2, free of any water and impurities to avoid failure regarding injection pumping elements and nozzle.

4.3. Venting the fuel system

See chapter 7.

5. STARTING THE ENGINE

5.1. Before starting:

Check contents in the fuel tank and oil level in oilpan. Oil level should be at least between upper and lower mark on dipstick. Check oil level in air filter.

5.2. Electrical starting

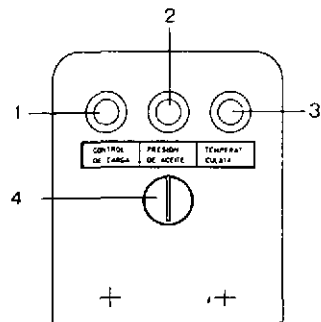

- a) Put ignition key into switch (charge indicator bulb comes on).
- b) Set speed adjustment lever (accelerator) to full speed (picture 4).
- c) Push starter button no longer than 20 seconds. To spare the battery, leave intervals of 30 to 60 seconds between attempts.

1. Charge indicator (red bulb).
2. Oil pressure indicator (green bulb).
3. Cylinder head temperature indicator (yellow bulb).
4. Ignition and starting switch.

5.2.1. Starting with hand crank

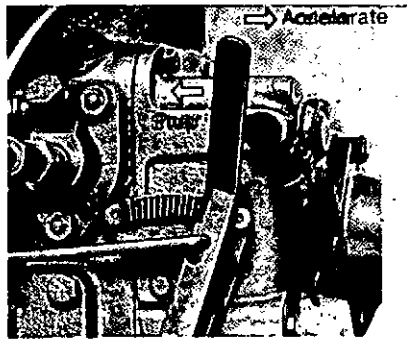

Picture 4



Picture 5

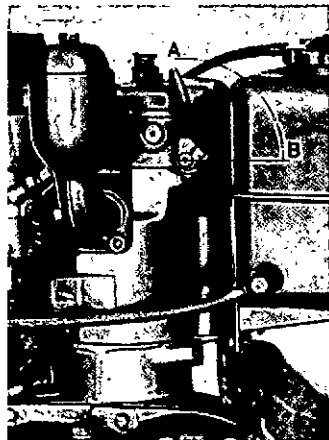

Picture 6

- a) Set governor lever to full speed (picture 4).
- b) Push overload button deeply (picture 5).
- c) Set decompressor lever in position «A» (picture 6).
- d) Start engine by means of the starting cranking handle. At the moment you recognize the distinctive squeak when injecting the fuel, decompression lever should be set in position «B» (picture 6) keeping the cranking handle revolving in order to overcome at least twice the compression strength. Engine should start now. In negative case, repeat again the same operation.

5.3. After start

When engine has started, the oil pressure gauge should immediately indicate a pressure of about 4 Kp/cm². At low idling speed and the engine warm, oil pressure must not drop below 0.5 Kp/cm², otherwise warning green lamp flashes on. Low oil pressure warning light should come on between 0.5 - 0.8 Kp/cm².

5.4. Observations during operation

When engine is running under load, watch the oil pressure gauge and the remote thermometer (delivered upon request). The green field appears in the window as long as temperature is normal. Green and red when engine temperature rises excessively. Cylinder head temperature should not exceed 190° C or 374° F.

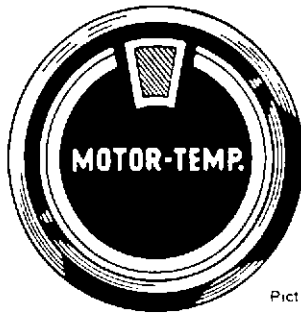

Red
or
green
field

Picture 7

When dial is fully red, stop the engine and trace the cause of overheating. If a remote connected alarm to the thermometer sounds, is then the last warning to stop the engine immediately.

NOTE! In case oil pressure drops, or the warning bulb flashes, stop the engine quickly, and determine the cause.

5.5. Stopping the engine

Remove load from engine and run it for a short period at idling speed, to allow it to cool down. Move speed control lever towards «stop» (picture 4) until the engine stops completely.

- Withdraw key from ignition switch.
- NEVER stop the engine with decompressor lever in position «A» (picture 6).
- Before a long period of standstill the engine should be inhibited.

6. ROUTINE MAINTENANCE

We advise you follow this summary of all maintenance work to be carried out regularly.

Daily or every 10 hours of operation.

Check oil level in oilpan (chapter 4.1.b).
Check fuel level in tank.

After 30 hours of operation.

First change of oil to be done.

After 70-80 working hours.

Carry out oil change regularly. Remove drain plug from the oil pan and let oil come out. Oil drainage must take place while the engine is still hot. Remove lateral cover (picture 8) and oil filtering sieve from the inset. Clean it by means of a solvent and let it dry before reinstallation. Mount oil filtering sieve, lateral cover and drainage plug. Now fill with oil (chapter 4.1).

Clean the air cleaner with solvent.

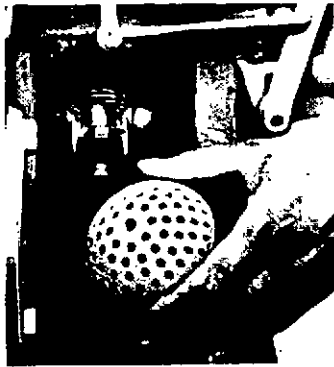

Picture 8

Try to avoid inner sediments. Remount the elements of the filter and fill the oil pan with new and clean oil (pict. 3).

USE ONLY ORIGINAL PARTS

Check the battery

(Every 4 weeks at the latest.)

The battery should be clean and dry outside. The electrolyte level should be approx. 10-15 mm above the upper edge of the plates. In a properly maintained battery, density of acid reveals the state of charge. At 20° C acid density should be:

1,285, charged; 1,23-1,21 half charged; 1,14-1,11 discharged.

Wash terminals with hot soda solution. Take care that no soda lye gets into the battery. Rinse with cold water and grease terminals with acid protection grease.

Check tightness of fuel pipes.**After every 250 hours of operation:**

Check the clearance of inlet and exhaust valves. In cold engine should be 0,2 mm. (See chapter 7.5)

After every 500 hours of operation.

Check the fuel filter. The filter is maintenance-free as long as fuel can pass through. Decreasing of engine output may be caused by lack of fuel supply. This can be checked by loosening the connection of the delivery pipe at the injection valve while engine running at high speed. Cleaning periods of the filter depend on the amount of dirt in the fuel, therefore no fixed order for cleaning can be indicated. For fuel filter cleaning see chapter 7.3.

Periodically check cylinder head temperature warning lights (ground out sending unit). Cleaning of the air cooling ducts will depend on the environment the engine is operating in.

Check all nuts and fixing bolts. Retighten them if necessary.

After every 2000 hours, check nozzle pressure.

7. Maintenance Guide**7.1. Venting the fuel system**

Venting is necessary:

- a) Before first start-up.
- b) After a long period of standstill.
- c) When pipes have been loosened or removed.
- d) Whenever air is in the system.
- e) When fuel filter has been cleaned or replaced.

7.2. Venting the injection pump

Unscrew vent-screw on the injection pump (picture 9). Set governor lever at maximum speed (picture 4). Place decompressor lever in position «A» (picture 6) and let the engine turn by means of the cranking-handle or starter, until fuel flows bubble-free from the vent screw. Tighten vent-plug again.

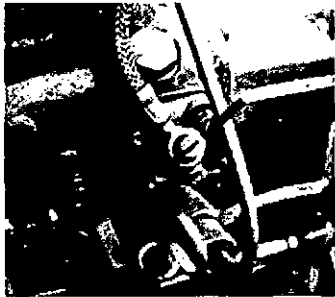

Picture 9



Picture 10



Picture 11

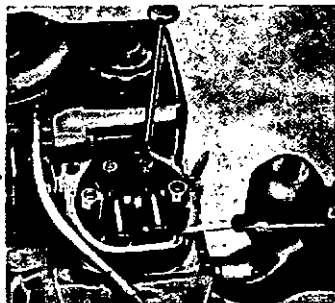

Picture 12

7.3. Fuel filter

To clean the fuel filter, unscrew the nut on the filter (picture 10). Dismount the felt insert and wash it and the inner pipe with clean solvent. Verify that the felt insert is in good condition, otherwise replace it. Picture 10 element part number 000.989.02.00.

7.4. Oil filter maintenance

ATTENTION! Renew the disposable filter every 160 working hours, that is after each second oil-change. Dismount the filter by turning counterclockwise. Clean the sealing surface of the filter head carefully with a fluff-free rag. Using your finger, lightly oil the gasket on the bottom of the new disposable filter before tightening. Start the engine and check filter for tightness. Refill with lube oil up to the upper mark on the dipstick. Part number for the oil filter is 9.987.1.740.200.4.

7.5. Adjustment of valve clearance

In cold engine valve clearance must be 0,24 mm. After each fitting of cylinder head, cylinder head cover, valves or camshaft, clearance is to be re-adjusted. For this purpose use a feeler gauge of 0,2 mm between valve stem and rocker arm, when valve is closed. (Picture 12) Valve clearance adjustment takes place at the end of the compression stroke, this is when both valves are closed.

8. TROUBLE SHOOTING

SYMPTOM	CAUSES AND REMEDIES																						
	1	2	3	4	5	6	7	8	9	10	11	12	13	14	15	16	17	18	19	20	21	22	23
Engine does not start	x	x	x	x		x	x	x	x		x					x							
Engine stops	x	x	x	x		x	x	x	x														
Engine smokes black						x	x	x	x	x	x	x	x			x							x
Engine blow by insufficient compression									x	x	x					x							
Engine knocks						x	x	x			x	x	x				x	x			x	x	
High consumption of lube oil																x	x						x
Engine output is insufficient						x	x	x	x	x	x						x	x				x	
Engine smokes white		x									x				x	x						x	x
Irregular speed		x				x	x		x														
How to use this list: When engine knocks, see points 5-6-7-10-11-12-17-18-20 and 21.																							

8.0. Causes and remedies

- | | |
|---|--|
| 1. Fuel filter clogged. | Dismantle fuel filter insert and clean or renew cartridge (Paragraph 7.3) |
| 2. Air in injection pump. | Bleed out air. |
| 3. Water in fuel. | Drain fuel tank and filter and refill with fresh fuel (Paragraph 7.2). |
| 4. Shortage of fuel. | Fill tank with fuel. |
| 5. Excess crank end play | Refit thrust bearings. |
| 6. Injection pump does not work reliably. | Have it checked by an authorized Murphy distributor. |
| 7. Nozzle clogged. | Dismantle injector and clean nozzles. Have it checked by an authorized Murphy distributor. |

- | | |
|--|---|
| 8. Valves leak. | Clean, grind or replace. Check valve rocker arm clearance. |
| 9. Insufficient compression. Engine turns by hand easily. | Grind valves. Check whether all valves are closed. In case cylinder head has been dismantled. Cylinder head studs must be uniformly and crosswise tightened. Adjust clearance between valve stem and rocker properly. |
| 10. Air filter choked. Engine shows signs of overload. | |
| 11. Cylinder head gasket faulty. | Renew cylinder head gasket. |
| 12. Connecting rod bearing, engine cam hot, piston seized. | Examine connecting rod bearing and piston, renew them if necessary. Change oil. |
| 13. Engine is overloaded. | Take off load. Keep constant number of revolutions. |
| 14. Engine over full with oil | Drain off excess oil. |
| 15. Piston rings are sticking. | Dismantle and clean piston. Replace rings. |
| 16. Piston rings are sticking. | Dismantle and clean piston. Replace rings. |
| 17. Fuel unsuitable. | Use suitable brand. |
| 18. Connecting rod bearing loose. | Check bearing clearance. If connecting rod bearings are damaged, renew them. |
| 19. Lubrication fails. Connecting rod bearing runs hot. | Oil level too low. Examine the oil pump and if necessary replace with a new pump. Suction filter clogged. Clean and flush sediments out. |
| 20. Piston has run dry, has seized or cooling fails. | Examine oil level in the crankcase and refill it if necessary. Clean air inlet screen and cooling system. |
| 21. Injection quantity altered. | Have quantity readjusted by a Murphy Diesel Distributor. |
| 22. Button for fuel starting is sticking. | Free push-button, until it comes out by itself after the engine has started. |
| 23. Wet exhaust. | Do not let engine run at low speed without load. |

9.1. Diesel Fuel

Normally the engine works with Diesel fuel, but all other fuels appropriate for diesel engines may be used if in conformity with the below given specifications (DIN 51601):

Requirements			Tested acc. to
Max. content of water	vol. %	0,1	DIN 51777
Density at 15° C	g/ml	0,820-0,860	DIN 51757
Boiling point at 360° C	vol. %	90	DIN 51752
Viscosity at 20° C	c/St.	1,8-10 (1,1-1,85° E)	DIN 51550
Flash point according to Abel-Pensky min.	°C	55	DIN 51755
Possibility of filtering	°C	In summer down to 0 In winter down to 12	DIN 51770
Max. sulphur content	weight %	1,0	DIN 51768
Carbon residue acc. to Conradson max.	weight %	0,1	DIN 51551
Reaction to zinc max. loss in weight	mg	4	DIN 51779
Ignition quality (cetane number) min.	CaZ	40	DIN 51773
Percentage of ashes max.	weight %	0,02	DIN 51575

Net calorific value appr. 10.000 Kcal.

Beginning paraffin separation (BPA) by 5° at least below the lowest room resp. outside temperature.

The fuel should not contain solid, insoluble impurities and must be free of mineral acids and alkalis.

9.2. Preservation of stored engines

If there are no particular instructions given for long storage preservation, our engines are preserved for a three months period under normal conditions.

If an engine thus preserved should not yet be put into operation after that time, another preservation is necessary.

Proceed the following way:

1. Fill with rust-preventing anti-corrosion oil of SAE 10 grade up to the lower dipstick mark.
2. Drain fuel system by loosening hollow screws on injection pump or fuel filter. Fill the whole system with rust-preventing oil SAE 10 grade through fuel filter (take inserts out) or through daily tank, if filters are mounted in low position.
3. Crank the engine several times by hand. Vent cylinders by loosening injection valves and put throttle in full load position.
4. Take cylinder head cover off, wipe out and spray with inhibiting oil. Spray valve springs.
5. Spray with inhibiting oil all shining parts, especially injection pump and governor.

If battery is available, procedure shown in point 3) can also be carried out by the electric starter motor.

ATTENTION!! Before starting the engine, check freedom of throttle movement.

Repeat same preservation procedure every 3 months.

Before using the engine, drain anti-corrosion oil from engine and fuel system. If engine is out of operation for more than one year, change anti-corrosion oil.

9.3. Air filter

Impurities and dust in the air cause heavy wear to the engine.

Frequency of sieve cleaning and oil changes depend on where the engine is working. Normally they should be cleaned every 10-125 running hours.

Oil contained in pan should be checked after the engine has been stopped at least 1 and ½ hours or much better just before starting daily work.

BE CAREFUL! In order to avoid accidents do not handle inflammable liquids while you are cleaning the air filter.

Hours of operation								MAINTENANCE SCHEDULE	
4000	2000	1000-1250	500	200	100-120	70-80	30-40		8-10
								X	Check oil level when engine is stopped and eventually refill with oil to the upper mark on dipstick. Check fuel level.
								X	First change of oil after 30 hours. Second change of oil after 60 hours.
						X			Change oil regularly. For every change of oil, unscrew plug on crankcase.
					X				Clean air filter, and fuel filter. See chapt. 9.3 and 7.3
				X					Check the battery.
		X							Verify that in cold engine, valve clearance is 0,24 mm. between rocker-arm and valve. Renew oil filter every 160 hours. Check cell terminals in the battery.
		X							Verify injector, injection pressure 180 + 5 Kg/cm ² . Clean cylinder cooling ribs, cylinder head and flywheel blades. If it works in a dusty atmosphere, clean every 100 hours. Verify thermometer for cylinder head temperature is working. Check all nuts and bolts. Verify tightening.
X	X								Check the engine.
X	X								General survey of the engine.

Wiring diagram for D Series engine LKS, D302-1, 302-2 with Femsa generator.

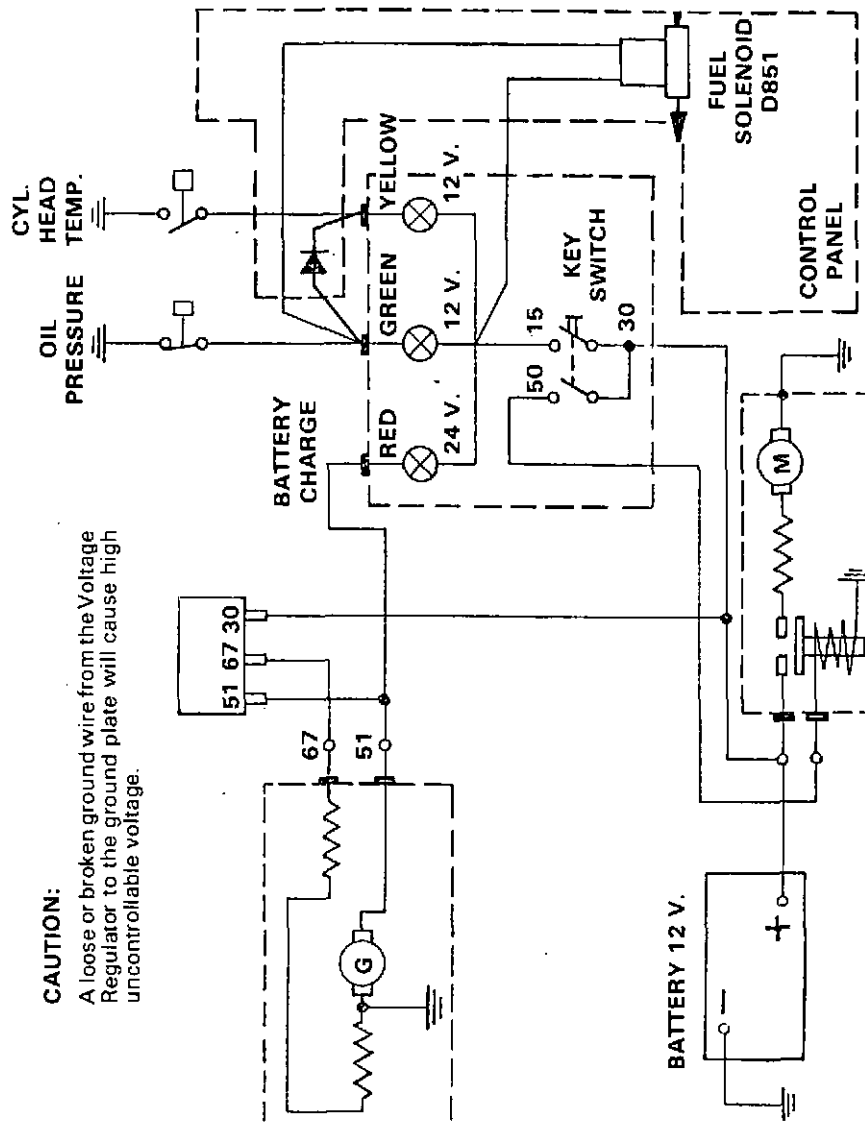

CAUTION:

A loose or broken ground wire from the Voltage Regulator to the ground plate will cause high uncontrollable voltage.

NOTES

Generator V-belt part number 434-23
9.5 x 612.55

V-belt part number 434-17
9.5 x 6.75

Lube oil filter part number
9.987.1.740.200.4

Fuel oil filter element part number
000.989.02.00

42-103

2-81-500 OMNI GRAPHICS