

MWM
DIESEL

SHOP MANUAL

D302 SERIES

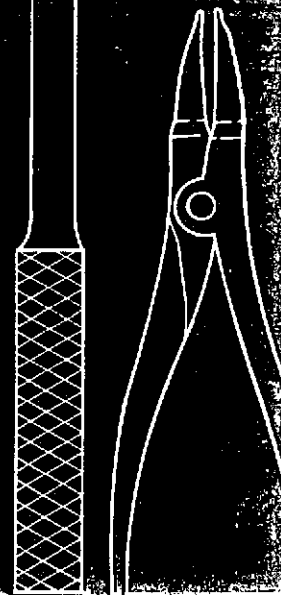
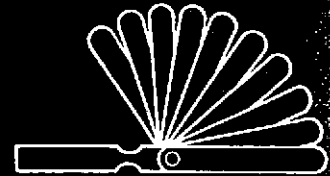
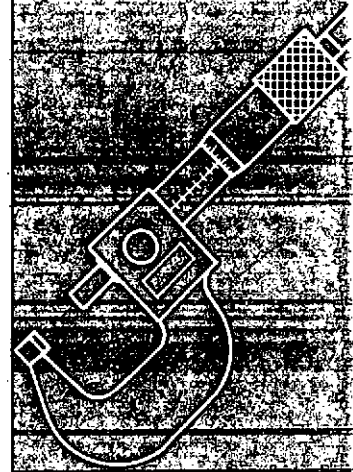

MWM Diesel, Inc.

3200 Pointe Parkway
Norcross, Georgia 30092
(404) 441-1384
Telex 6712325 MWMMD

Assembly Instructions

This Manual is primarily designed for workshop use and contains useful information on engine disassembly and assembly.

The tasks involved are described and illustrated in the specified sequence.

Go/no go dimensions are stated for parts subject to wear, showing when these items need replacing.

The Operating Instructions serve as a supplement to this Repair Manual.

Please do not hesitate to get in touch with our Service Department should you require additional information pertaining to this Manual.



MWM DIESEL, INC.
5317 W. Burnham St.
Milwaukee, WI 53219
Phone: 414-645-2255
Telex: 6712325 MWMMD

CONTENTS

Page Nos.

General Engine Data	3
Performance Curves	
D302-1 Standard Output	4
D302-2 Standard Output	5
D302-2 High Output	6
D302-3 Standard Output	7
D302-3 High Output	8
Technical Data	
Electrical System	9
Lubrication System	10-11
Cooling Air System	12
Combustion Air System	13
Exhaust System	14
Fuel System	15-16
Cross Sections of Engines	
D302-1	17
D302-2	18
D302-3	19
Systems Operation	
Electrical	
Indicator Light Panel w/Femsa Generator	20
Indicator Light Panel w/Motorola Alternator	21
Switch Gauge Panel w/Motorola Alternator	22
Service Note on Raising Low Pressure Signal	24
Lubrication Flow	
D302-1 and D302-2	25
D302-3	26
Cooling Air Flow	27
Fuel Flow	28
Governor Operation	29
Go/No Go Dimensions of Wearing Parts	30-47
Refurbishing Grades (Machinable Surfaces)	48-49
Crankshaft	49
Camshaft	50
Camshaft Bore in Cylinder Block	50
Cylinder Liner	51
Cylinder Head	51
Engine Disassembly and Assembly Procedures	52
Special Service Tools	52
General Disassembly and Assembly Procedures	53-65
Standard Torque Values	67
Special Torque Specifications	68
Bearing Clearances	70
Gear train Timing	70
Gear Backlash	71
Piston Clearance (dial indicator)	71
Compression Clearance (lead wire check)	71
Fuel Injection Pump Timing	72-75
Governor Adjustments	76-83
Crankshaft Seals	84-85

CONTENTS (Cont.)

Page Nos.

Service Notes	86-89
Troubleshooting	91-99
Checking Compression Pressure	91
Testing Fuel Injection Nozzles	92-93
Lube Oil Pressure	93
Lube Oil Consumption	93
Valve Timing	94
Valve Sealing	94
Fuel Consumption	94
Troubleshooting Charts	95-99
Preventive Maintenance and Overhaul Schedule	100-101
Metric Conversion Charts	

GENERAL ENGINE DATA

Model	D302		
Number of cylinders	1	2	3
Combustion cycles		4	
Combustion system		direct injected	
Turbocharger	no	no	no
Bore/Stroke mm (inches)		95/105 (3.74/4.13)	
Compression ratio		17.5:1	
Ignition pressure max bar (psi)		85 (1232)	
Total displacement liters (CID)	.745 (45.5)	1.49 (90.8)	2.23 (136.2)
Crankshaft rotation		counterclockwise (viewed from rear)	
Firing order (from rear)	1	1-2	1-3-2
Maximum operation speed (rpm)		3000	
Minimum idle speed		650	
Dry weight approx. kg (lbs.)	170 (375)	225 (495)	260 (575)
Valve clearance cold mm (inches)		0.2 (.008)	



AIR COOLED DIESEL

ENGINE MODEL
D302-1
STANDARD OUTPUT (ONLY)

BORE: 95 mm/3.74 in.
STROKE: 105 mm/4.13 in.
DISPL: .745 l/45.5 in.³

TYPE: N.A. - 4 Stroke Cycle
CERTIFIED: *Rhita Schneider*
CORRECTED TO: S.A.E. J 270 (A&B)
 85°F (29°C)
 29.38 in. Hg. (99.2 KPa)

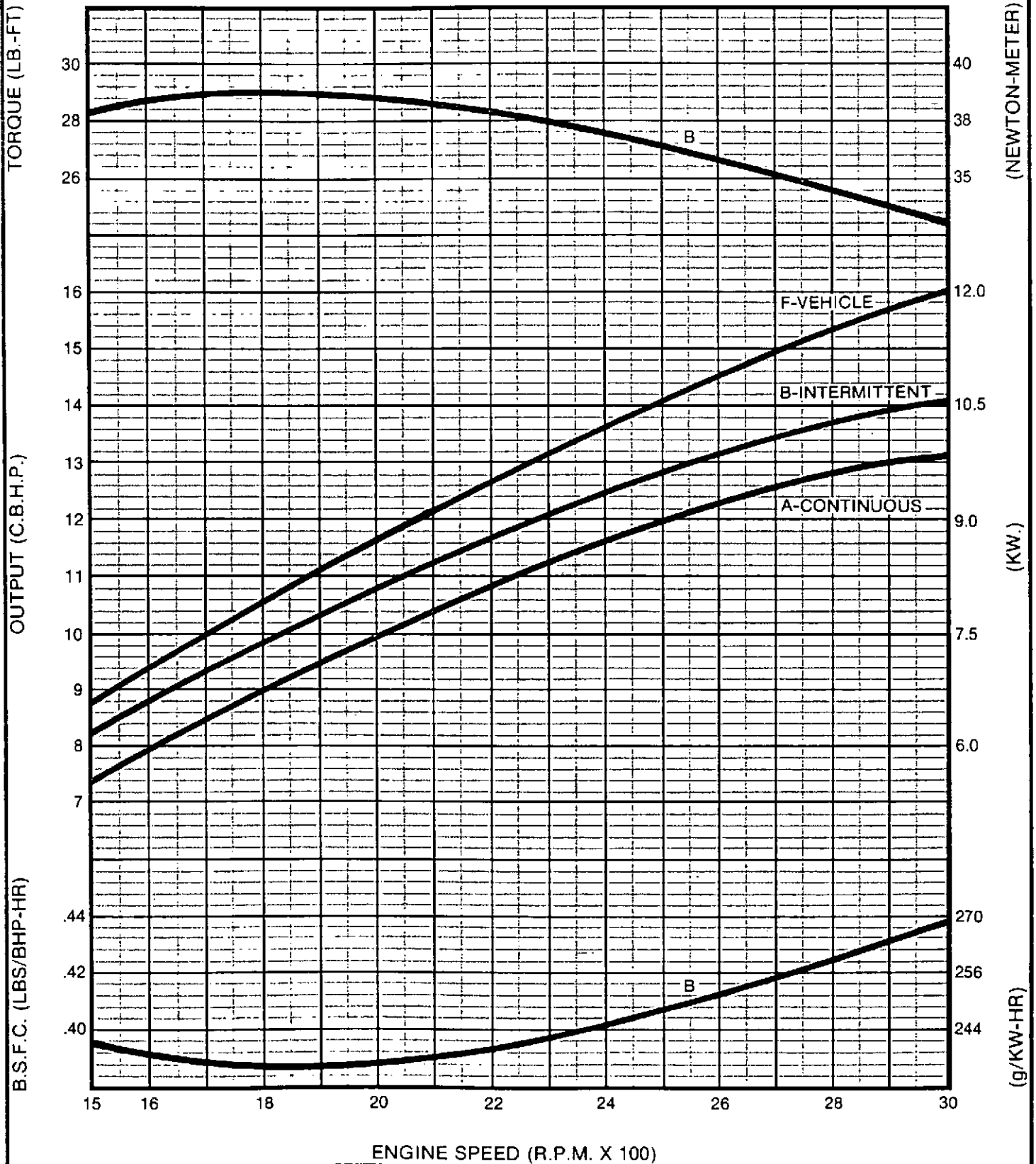



AIR COOLED DIESEL

ENGINE MODEL
D302-2
STANDARD OUTPUT

BORE: 95 mm/3.74 in.
STROKE: 105 mm/4.13 in.
DISPL: 1.49 l/90 in.³

TYPE: N.A. - 4 Stroke Cycle
CERTIFIED: *WTA Schindl*
CORRECTED TO: S.A.E. J 270 (A&B)
85° F (29° C)
29.38 in. Hg. (99.2 KPa)

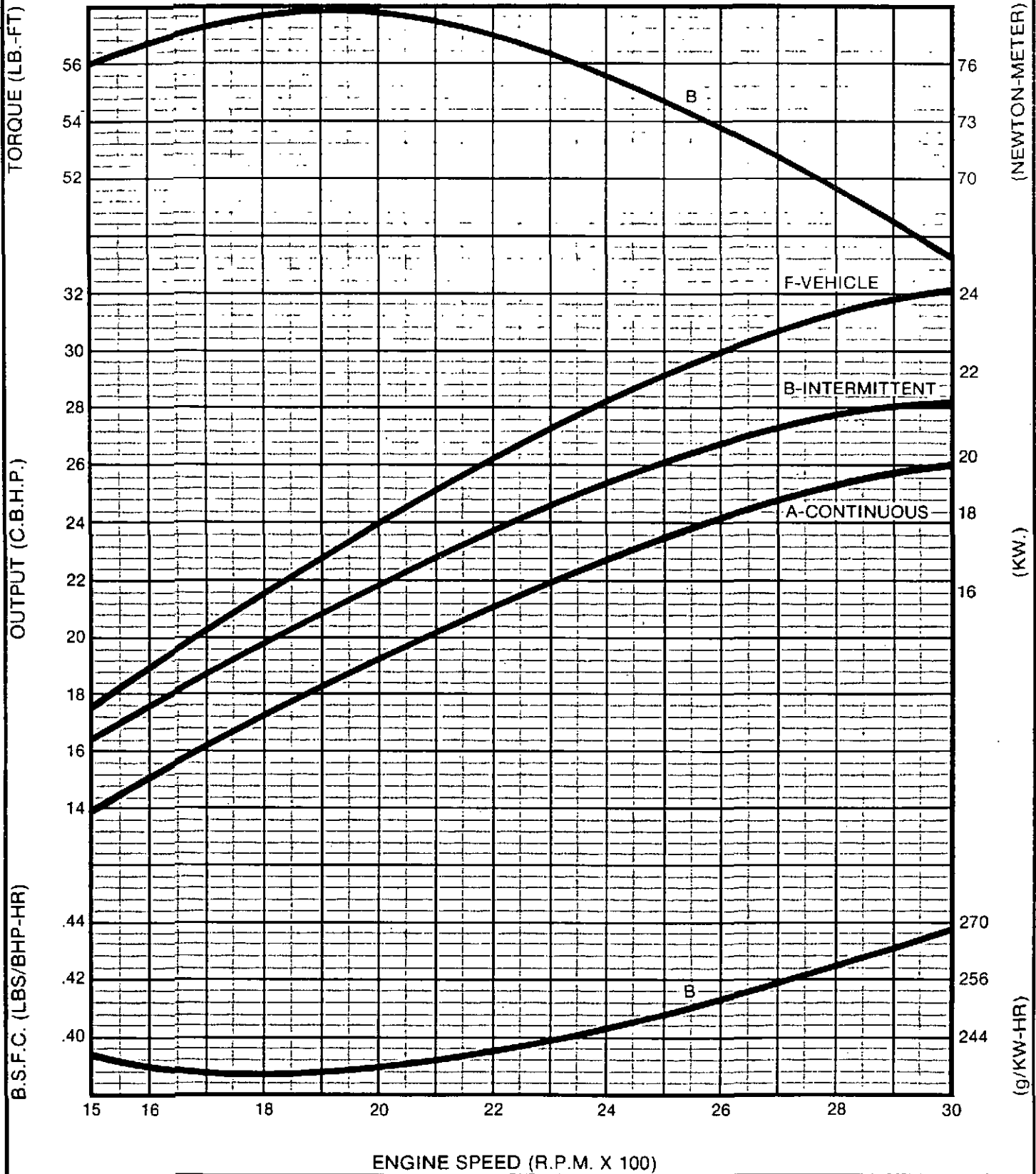



AIR COOLED DIESEL

ENGINE MODEL
D302-2
HIGH OUTPUT

BORE: 95 mm/3.74 in.
STROKE: 105 mm/4.13 in.
DISPL.: 1.49 l/90 in.³

TYPE: N.A. - 4 Stroke Cycle
CERTIFIED: *Wata Shinko*
CORRECTED TO: S.A.E. J 270 (A&B)
85° F (29° C)
29.38 in. Hg. (99.2 kPa)

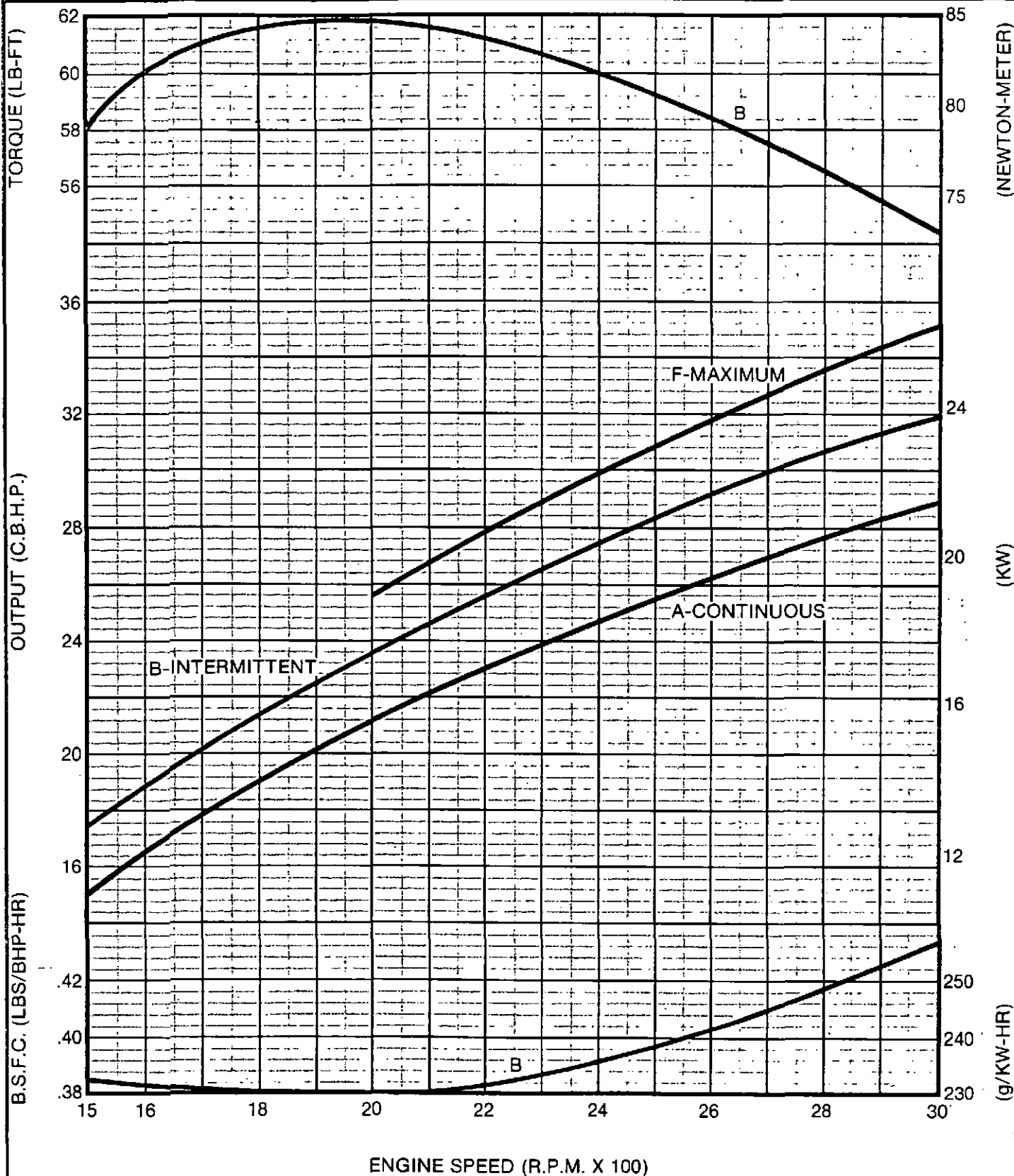



AIR COOLED DIESEL

ENGINE MODEL
D302-3
STANDARD OUTPUT

BORE: 95 mm/3.74 in.
STROKE: 105 mm/4.13 in.
DISPL: 2.233 l/136 in.³

TYPE: N.A. - 4 Stroke Cycle
CERTIFIED: *Adel O. Schmidt*
CORRECTED TO: S.A.E. J 270 (A&B)
 85° F (29° C)
 29.38 in. Hg. (99.2 KPa)

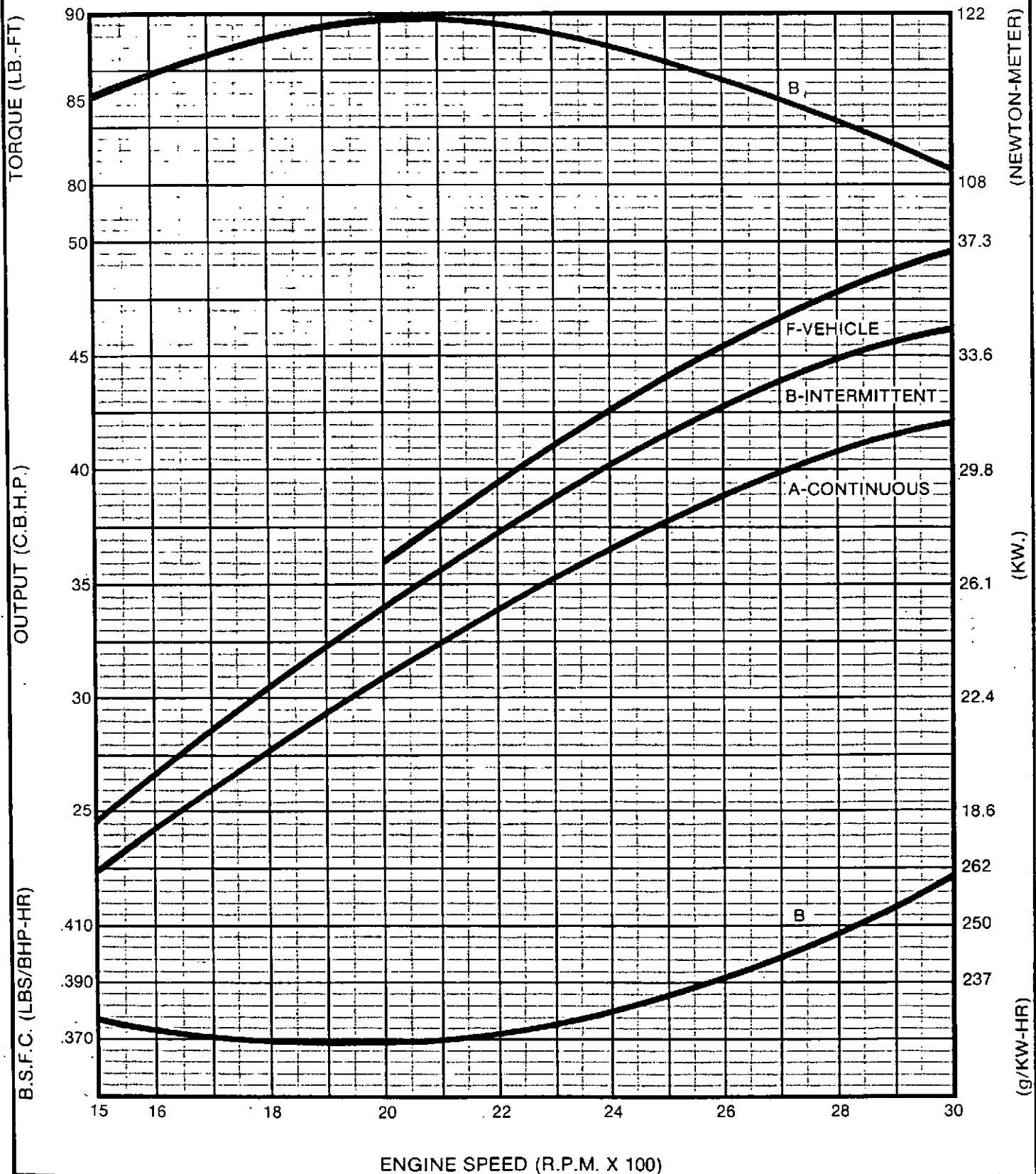



AIR COOLED DIESEL

ENGINE MODEL
D302-3
HIGH OUTPUT

BORE: 95 mm/3.74 in.
STROKE: 105 mm/4.13 in.
DISPL.: 2.233 l/136 in.³

TYPE: N.A. - 4 Stroke Cycle
CERTIFIED: *Rhys A. Schneider*
CORRECTED TO: S.A.E. J 270 (A&B)
85° F (29° C)
29.38 in. Hg. (99.2 kPa)

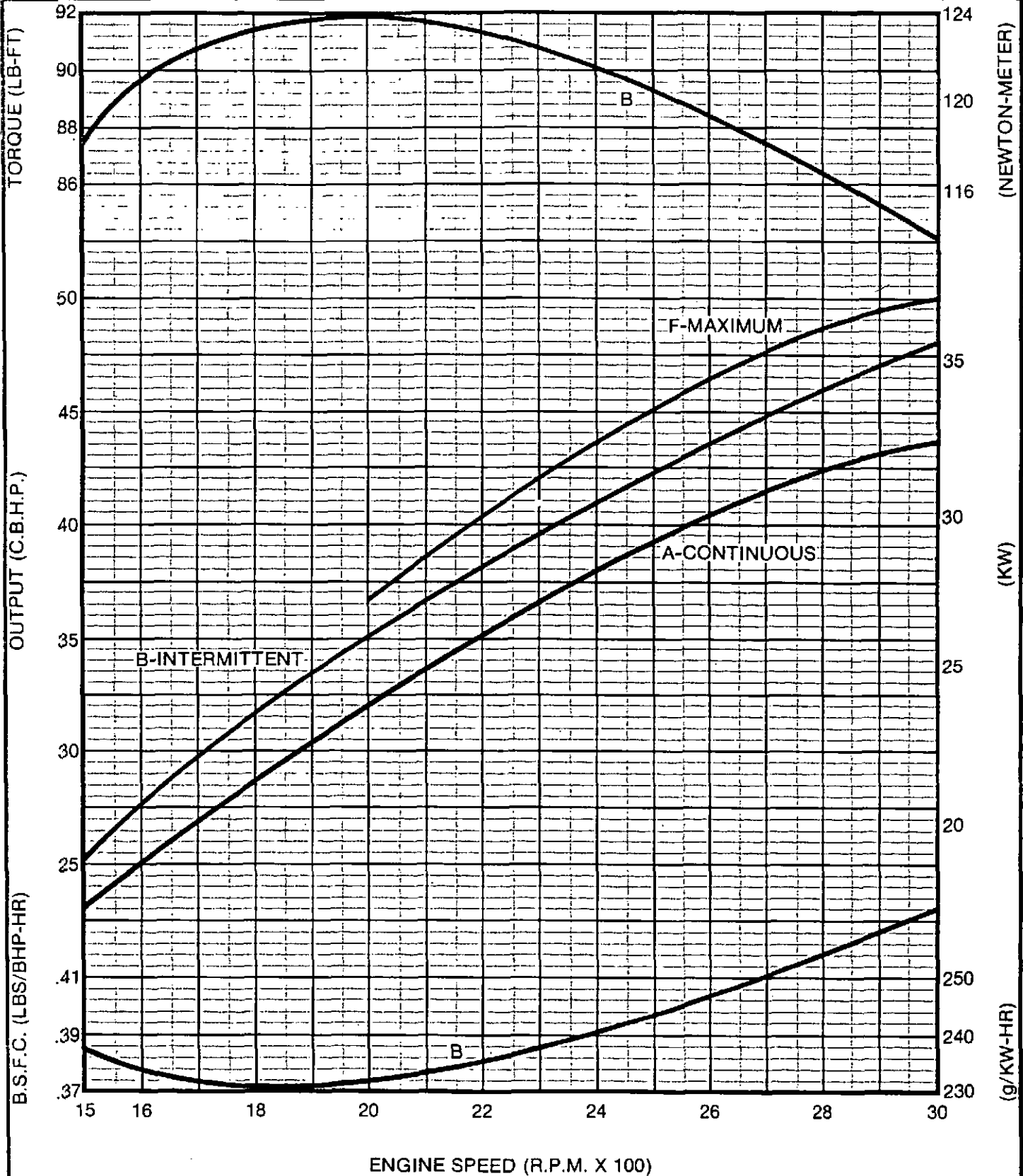

ELECTRICAL SYSTEM

STARTING SYSTEMS

ELECTRIC:

Delco-Remy, 12 volt D.C. Model 10 MT

MANUAL:

Optional hand crank device and manual decompression lever — high mass BZ 253 flywheel and deep (B043) housing required on D302-2 and D302-3.

AIR:

D302-2 and D302-3 with dusterloh DLA 1.5 air starter.

RECOMMENDED BATTERY SIZE:

CONDITION/MODEL	D302-1	D302-2	D302-3
ABOVE 10° F	360 CCA	360 CCA	400 CCA
BELOW 10° F	360 CCA	500 CCA	510 CCA

TEMPERATURE LIMITS FOR STARTING:

METHOD/MODEL	D302-1	D302-2	D302-3
ELECTRIC	5° F	5° F	5° F
MANUAL	20° F	20° F	20° F
ELECTRIC W/ COLD START AID	-20° F	-20° F	-20° F

CHARGING SYSTEMS

Motorola 37 amp., 12 volt D.C. with self contained solid state voltage regulator.

Motorola 55 amp., 12 volt D.C. with solid state regulator attached.

Motorola 37 amp., 12 volt D.C. with enclosed brushes, U.L. approved for marine (also for adverse industrial applications) with solid state regulator attached.

LUBRICATION SYSTEM

LUBE OIL PRESSURE:

(With 20W oil @ 212°F)

Normal at 1500 to 3000 RPM 50-80 PSI
Minimum 20 PSI

MAXIMUM LUBE OIL TEMPERATURE 240°F.

LUBE OIL VISCOSITY AND SERVICE CLASS:

Use a good quality oil having an API service class CC/SF, CD/SF, CC or CD according to the following viscosity. (See section on Diesel Fuel under "FUEL SYSTEM" for further information on API service class with regard to Sulfur Content.) Use of multi-viscosity oils in MWM diesel engines must meet an API service class of CD/SF or CD.

AVERAGE OUTSIDE TEMPERATURE	SAE STRAIGHT WEIGHT	SAE MULTI-VISCOSITY
Above 85°F (30°C)	40*	—
32° to 85°F (0° to 32°C)	30*	15 W-40
14° to 50°F (-10° to 10°C)	20W - 20*	15 W-40
Permanently Below 32°F (0°C)	10W	10 W-30* or 5 W-20*

* Preferred

Using any quality oils other than those recommended could cause engine damage. For example, do not use oil labeled **ONLY SA, SB, SC, SD, SE, SF, CA or CB.**

LUBE OIL CONSUMPTION:

Nominal on an engine after run-in: .002 to .004 LB/HP/HR.

LUBE OIL PUMP FLOW (@ 3000 RPM)

D302-2	D302-3
4.75 GPM	8.0 GPM
(18 L/MIN)	(30 L/MIN)

LUBRICATION SYSTEM (Cont.)

STANDARD SUMP

	D302-1		D302-2		D302-3	
	CONT. DUTY	INT. DUTY	CONT. DUTY	INT. DUTY	CONT. DUTY	INT. DUTY
LONGITUDINAL	12°	30°	15°	35°	15°	25°
TRANSVERSE	15°	30°	15°	35°	15°	35°

INTERMITTENT DUTY: 15 MIN. MAX.

LUBE OIL
PAN CAPACITY
(U.S. QUARTS)

D302-1	D302-2	D302-3
2.75	5.3	7.1

LUBE OIL FILTERS

LUBE OIL FILTER WARNING

Due to high lubricating oil flow rates and pressures of MWM Diesel engines, specially engineered filters with high pressure by-pass valves (36 psi), antidrain-back valves and flow capabilities are required for safe operation and ultimate durability.

Genuine MWM Diesel replacement filters and spare parts are required on all MWM Diesel engines to insure continued long life and maintain "IN WARRANTY" coverage.

MODEL	D302-1	D302-2	D302-3
Filter Part No.	MD438-13	MD438-13	MD438-14
Filter Capacity	0.5 Quart	0.5 Quart	1.0 Quart

COOLING AIR SYSTEM

BLOWER INLET VOLUME IN CFM AT 68°F

RPM/MODELS	D302-1	D302-2	D302-3
1500	111	410	590
1800	135	470	700
2500	200	650	950
3000	247	765	1175

MAXIMUM BLOWER INLET RESTRICTION

0.6 inch H₂O

DISCHARGE AIR TEMPERATURE IN °F*

* Measured 25 mm (1") from push rod tube centers.

CONDITION	RPM	D302-1	D302-2	D302-3
NORMAL	1800	200	167	185
MAX.	1800	230	194	220
NORMAL	3000	185	175	185
MAX.	3000	212	205	212

DISCHARGE AIR MASS HEAT REJECTION IN BTU/MIN AT "A" RATING — (NOT INCLUDING ENGINE OIL COOLER)

RPM/MODEL	D302-1	D203-2	D302-3
1500	225	485	735
1800	275	575	910
2500	404	815	1385
3000	476	985	1580

AVERAGE SPECIFIC HEAT REJECTION IN BTU/HP/HR

D302-1	D302-2	D302-3
2260	2162	2100

COMBUSTION AIR SYSTEM

COMBUSTION AIR VOLUME

In (CFM) @ 68° F And 29 (Inch-Hg)

RPM/MODEL	D302-1	D302-2	D302-3
1500	18	35	54
1800	23	45	70
2500	27	55	81
3000	31	62	93

ALLOWABLE RESTRICTION OF INTAKE SYSTEM WITH NEW AIR CLEANER inches H₂O

RPM/MODEL	D302-1	D302-2	D302-3
1500	3.0	4.0	4.0
1800	3.0	4.0	4.0
2400	3.6	4.2	6.0
3000	3.6	4.7	7.8

MAX. RESTRICTION	D302-1	D302-2	D302-3
	20	20	20

COMPRESSION PRESSURE

Normal: 25-30 bar (363-435 psi)
Minimum: 22 bar (319 psi)
Maximum compression pressure difference between cylinders: 3 bar (43 psi)
(Compression pressure measured at cranking speed, engine cold)

CRANKCASE PRESSURE

MODEL	D302-1	D302-2	D302-3
Max. in. H ₂ O		1.0	1.0

EXHAUST SYSTEM

AVERAGE EXHAUST GAS TEMPERATURE °C (°F)

RATING	MODEL	D302-1	D302-2	D302-3
	RPM			
"A" RATING	1500	300 (572)	350 (662)	360 (680)
	1800	320 (608)	370 (698)	375 (707)
	2500	380 (716)	420 (788)	430 (806)
	3000	420 (788)	460 (860)	480 (896)
"B" RATING	1500	350 (662)	380 (716)	395 (743)
	1800	365 (689)	400 (752)	420 (788)
	2500	420 (788)	460 (860)	470 (878)
	3000	480 (896)	500 (932)	510 (950)

MAXIMUM EXHAUST GAS TEMPERATURE

at manifold outlet flange 640°C (1184°F)

MAXIMUM TEMPERATURE DIFFERENCE BETWEEN CYLINDERS

30°C (86°F)

MAXIMUM ALLOWABLE EXHAUST BACK PRESSURE

5.5 (In-Hg)

EXHAUST GAS VOLUME (E.G.V. IN C.F.M.)

Use the following formula:

$$\text{E.G.V.} = \left[\text{Intake air (C.F.M.)} \times \left(\frac{\text{Exhaust air temperature (°F)} + 460}{\text{Intake air temperature (°F)} + 460} \right) \right]$$

FUEL SYSTEM

MAX. FUEL FEED PUMP LIFT

3 (ft. fuel)

MAX. FUEL FEED PUMP SUCTION

2.6 (In-Hg) measured at pump inlet.

FUEL FEED PUMP PRESSURE

5.6 - 9.5 (p.s.i.) measured at pump outlet.

INJECTION PUMP PRESSURE (Controlled by injection nozzle opening pressure)

180-185 bar (2610-2680 psi) standard output engines — injector nozzle I.D. number CKBL88SD5270.

220-225 bar (3190-3260 psi) high output engines — injector nozzle I.D. number CKBL88SD5459.

FUEL FILTER

All models: part number MD 438-15

FUEL CONSUMPTION

Pounds per HP/HR. (Based on #2D at 19,400 BTU/lb. HHV).

RATING AND SPEED	LOAD	D302-1	D302-2	D302-3
"A" RATING @ 1800 RPM	FULL 3/4 1/2	.357 — —	.349 — —	.346 — —
"B" RATING @ 1800 RPM	FULL	.352	.345	.342
"A" RATING @ 3000 RPM	FULL 3/4 1/2	.414 — —	.407 — —	.402 — —
"B" RATING @ 3000 RPM	FULL	.407	.403	.399

All values in LBS/HP/HR and are an average based upon an engine fully broken in (over 100 hrs.) using #2D diesel fuel at an HHV of 19400 BTU/LB.

Use a good quality diesel fuel conforming to DIN 51601 or ASTM #2D. A cetane rating of 40 (min) is required for the proper operation of the engine. (See operator's manual.)

REDUCE RATED POWER

3% for each 1000 feet above 1000 feet.

REDUCE RATED POWER

2.5% for each 10°F above 85°F

INCREASE RATED SPECIFIC FUEL CONSUMPTION

1.5% for each 1000 feet above 1000 feet.

INCREASE RATED SPECIFIC FUEL CONSUMPTION

2.5% for each 10°F above 85°F.

FUEL SYSTEM (CONT.)

DIESEL FUEL

Use a good quality fuel meeting the ASTM D975, Grade 1-D (Number 1) or ASTM D975, Grade 2-D (Number 2).

Below are some notes with regard to diesel fuel:

Cleanliness: Take precautions to keep fuel free of water and sludge. Water will damage the injection pump and injection nozzles. If water becomes a problem, special fuel/water separators are available from several filter manufacturers for use on the engine. If water is a problem in stored fuel, contact the fuel supplier. Drain a little fuel from fuel tanks periodically to check for presence of water.

Sulfur Content: During combustion, sulfur in the fuel forms sulfur oxides which combine with the moisture in the intake air to produce sulfuric acid. The acid collects in the engine's lubrication system. The lubricating oil contains additives that will neutralize this acid and prevent it from attacking cylinder liners, rings, valves, etc. The amount of sulfur in the fuel will determine how fast this neutralizing additive will be used up, at which time, the oil should be changed. If sulfur content in the fuel is 0.5% or below, a CC/SF, CD/SF, CC or CD oil may be used. If the sulfur content exceeds 0.5%, a CD/SF or CD oil **must** be used (see Lubrication System). A "TBN" count in a used lube oil analysis will aid in basing lube oil drain intervals with regard to sulfur content.

Cloud Point: The cloud point is that temperature at which wax crystals begin to form in diesel fuel. These wax crystals quickly plug fuel filters, which cuts off the fuel supply to the engine. The selection of a suitable fuel for low temperature operability is the responsibility of the fuel supplier and engine user. The cloud point for No. 1 diesel fuel will occur at a lower temperature than it will for No. 2. However, using No. 1 may result in a loss of power and decrease in fuel economy as compared to using No. 2. Some fuel suppliers have elected to distribute a "blend" which contains a certain percentage of No. 1 mixed with No. 2. Other fuel suppliers will mix various fuel additives with No. 2 to improve low-temperature operation. If waxing is a problem, the owner can take preventive measures by using fuel heaters.

Additives: Drained Lube Oil—MWM Diesel, Inc. does not recommend the use of drained lubricating oil in diesel fuel. Furthermore, MWM will not be responsible for any detrimental effects which they determine has resulted from this practice.

Gasoline, Gasohol, Alcohol, Diesohol — Should never be added to diesel fuel. Explosive and fire hazards exist if a blend of these is mixed and/or burned.

Isopropyl alcohol (isopropanol)—Very small amounts may be used to prevent fuel line freeze-up in winter months. No more than one (1) pint of isopropyl alcohol should be added to 125 gallons of diesel fuel (0.5 liter to 500 liters diesel fuel) for adequate protection.

Miscellaneous Fuel Additives — MWM Diesel, Inc. does not endorse the use of the many fuel additives available on the market. The time and expense involved in testing all of these fuel additives, to separate the good from the bad, is prohibitive.

CROSS SECTIONS OF ENGINES

Engine End — Sectional View D 302-1

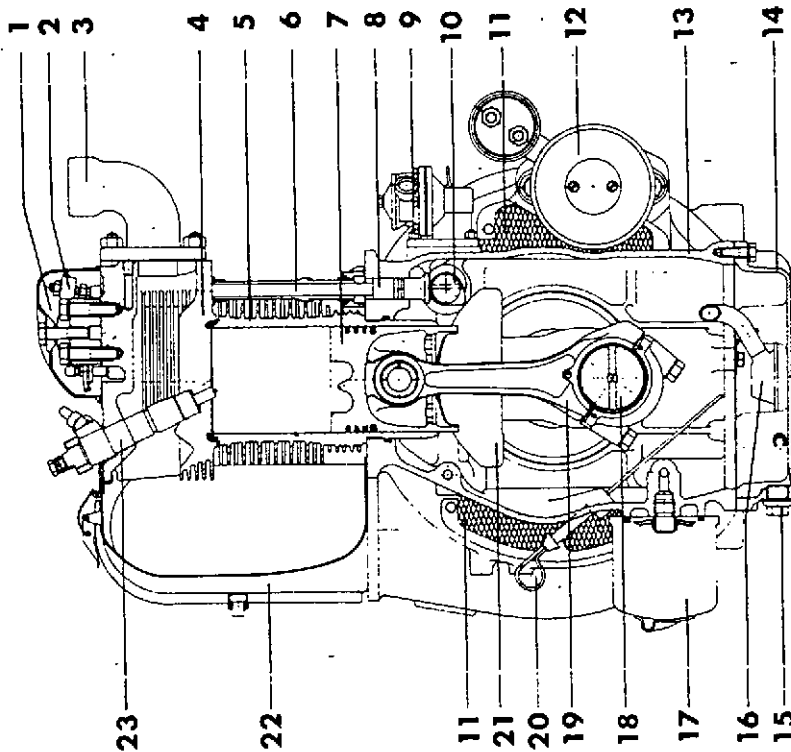

- 1 Cylinder head cover
- 2 Rocker arm
- 3 Intake pipe
- 4 Cylinder head
- 5 Finned cylinder
- 6 Pushrod
- 7 Piston
- 8 Tappet
- 9 Fuel delivery pump
- 10 Camshaft
- 11 Cooling air inlet
- 12 Starter

- 13 Crankcase
- 14 Oil sump
- 15 Oil drain plug
- 16 Lube oil suction line
- 17 Lube oil change filter
- 18 Crankshaft
- 19 Connecting rod
- 20 Oil dipstick
- 21 Counterweight
- 22 Cooling air guide
- 23 Injector

Engine Side — Sectional View D 302-1

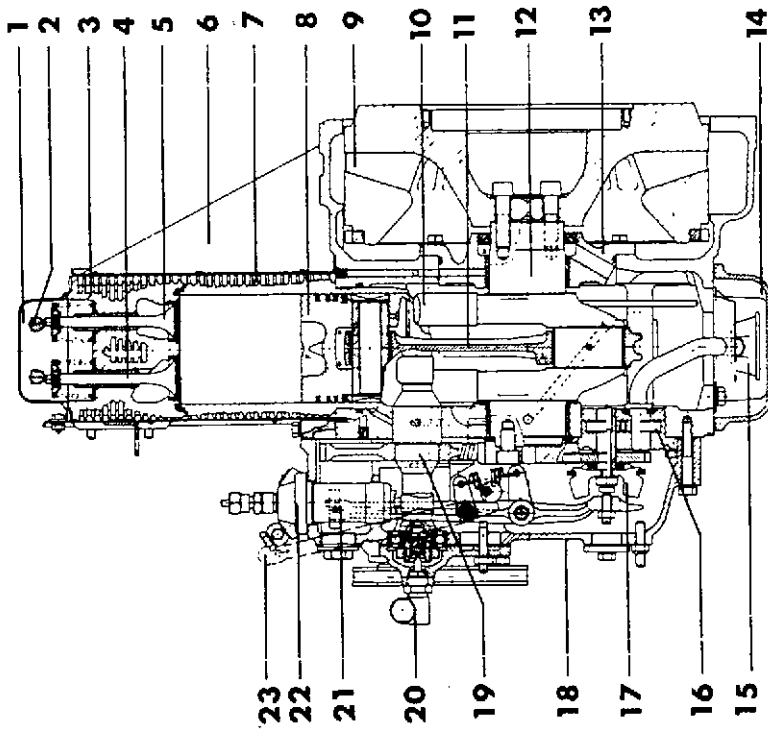

- 1 Cylinder head cover
- 2 Rocker arm
- 3 Cylinder head
- 4 Inlet valve
- 5 Exhaust valve
- 6 Cooling air guide
- 7 Finned cylinder
- 8 Piston
- 9 Flywheel (blower type)
- 10 Counterweight
- 11 Connecting rod
- 12 Crankshaft

- 13 Bearing cover
- 14 Oil sump
- 15 Lube oil suction line
- 16 Oil pump
- 17 Governor
- 18 End cover
- 19 Camshaft
- 20 Angular gear for rev counter
- 21 Speed adjusting lever (internal)
- 22 Injection pump
- 23 Speed adjustment lever (outer)

Engine End — Sectional View D 302-2

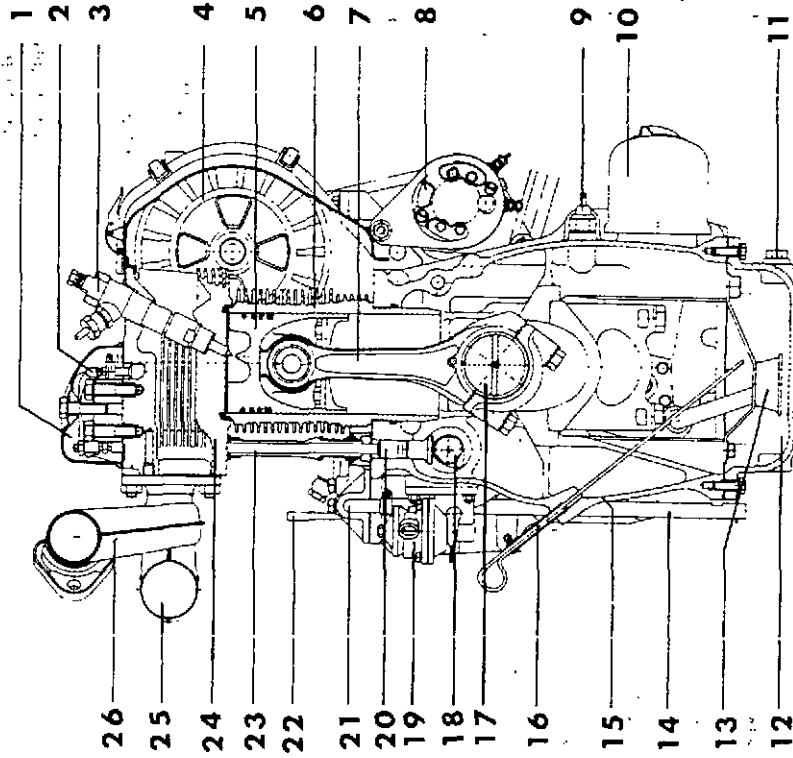

- | | |
|----|---|
| 1 | Cylinder head cover |
| 2 | Rocker arm |
| 3 | Injector |
| 4 | Cooling air blower |
| 5 | Piston |
| 6 | Finned cylinder |
| 7 | Connecting rod |
| 8 | Generator |
| 9 | Oil pressure switch (pressure gauge connection) |
| 10 | Lube oil change filter |
| 11 | Oil drain plug |
| 12 | Oil sump |
| 13 | Lube oil suction line |
| 14 | Breather pipe (crank chamber) |
| 15 | Crankcase |
| 16 | Oil dipstick |
| 17 | Crankshaft |
| 18 | Camshaft |
| 19 | Fuel delivery pump |
| 20 | Tappet |
| 21 | Engine breather |
| 22 | Speed adjustment lever |
| 23 | Pushrod |
| 24 | Cylinder head |
| 25 | Intake pipe |
| 26 | Exhaust pipe |

Engine Side — Sectional View D 302-2

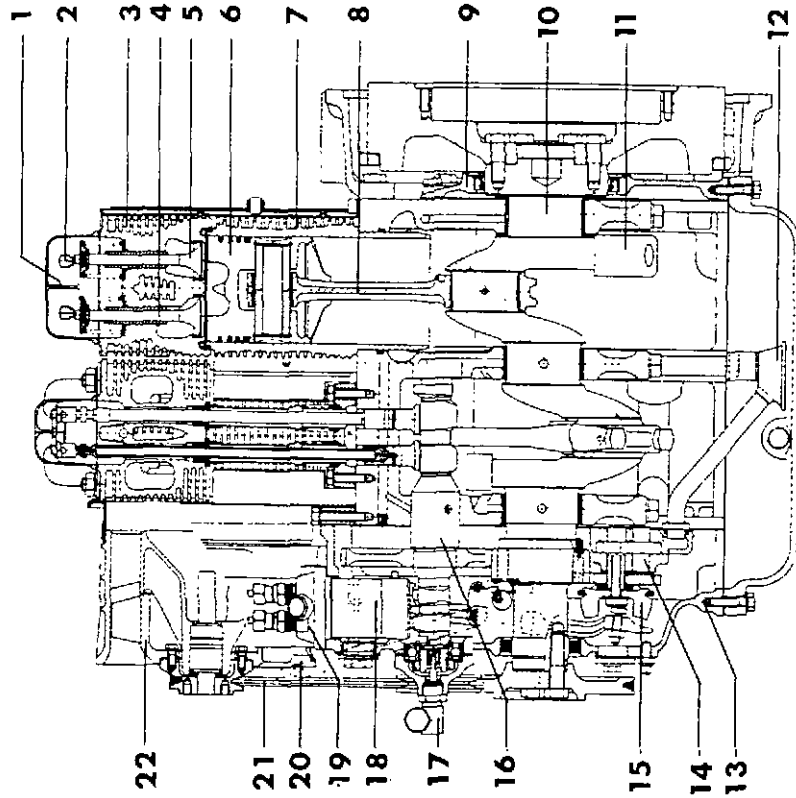

- | | |
|----|-----------------------------------|
| 1 | Cylinder head cover |
| 2 | Rocker arm |
| 3 | Cylinder head |
| 4 | Inlet valve |
| 5 | Exhaust valve |
| 6 | Piston |
| 7 | Finned cylinder |
| 8 | Connecting rod |
| 9 | End cover (flywheel end) |
| 10 | Crankshaft |
| 11 | Counterweight |
| 12 | Lube oil suction pipe |
| 13 | End cover (timing gear end) |
| 14 | Oil pump |
| 15 | Governor |
| 16 | Camshaft |
| 17 | Angular gear for rev counter |
| 18 | Speed adjustment lever (internal) |
| 19 | Injection pump |
| 20 | Speed adjustment lever (external) |
| 21 | V-belt |
| 22 | Cooling air blower |

Engine End — Sectional View D302-3

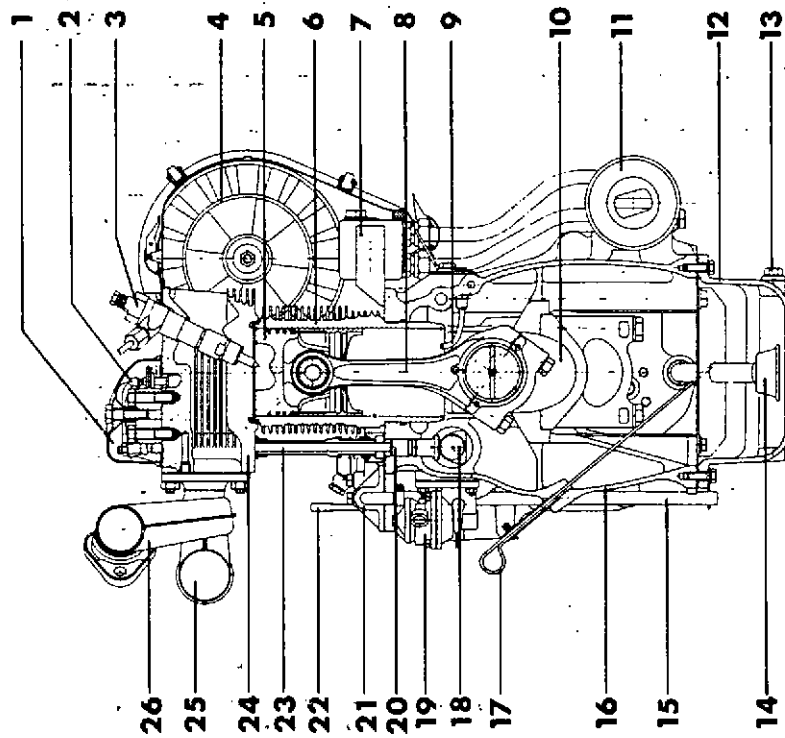

- 1 Cylinder head cover
- 2 Rocker arm
- 3 Injector
- 4 Cooling air fan
- 5 Piston
- 6 Finned cylinder
- 7 Oil cooler (D302-3 only)
- 8 Connecting rod
- 9 Spray nozzle for piston cooling (D302-3 only)
- 10 Crankshaft
- 11 Lube oil filter, replaceable
- 12 Oil pan
- 13 Oil drain plug
- 14 Cylinder head cover
- 15 Lube oil suction line
- 16 Crankcase breather
- 17 Oil dipstick
- 18 Camshaft
- 19 Fuel feed pump
- 20 Tappet
- 21 Engine ventilation
- 22 Speed control lever
- 23 Pushrod
- 24 Cylinder head
- 25 Exhaust pipe
- 26 Inlet pipe

Engine Side — Sectional View D302-3

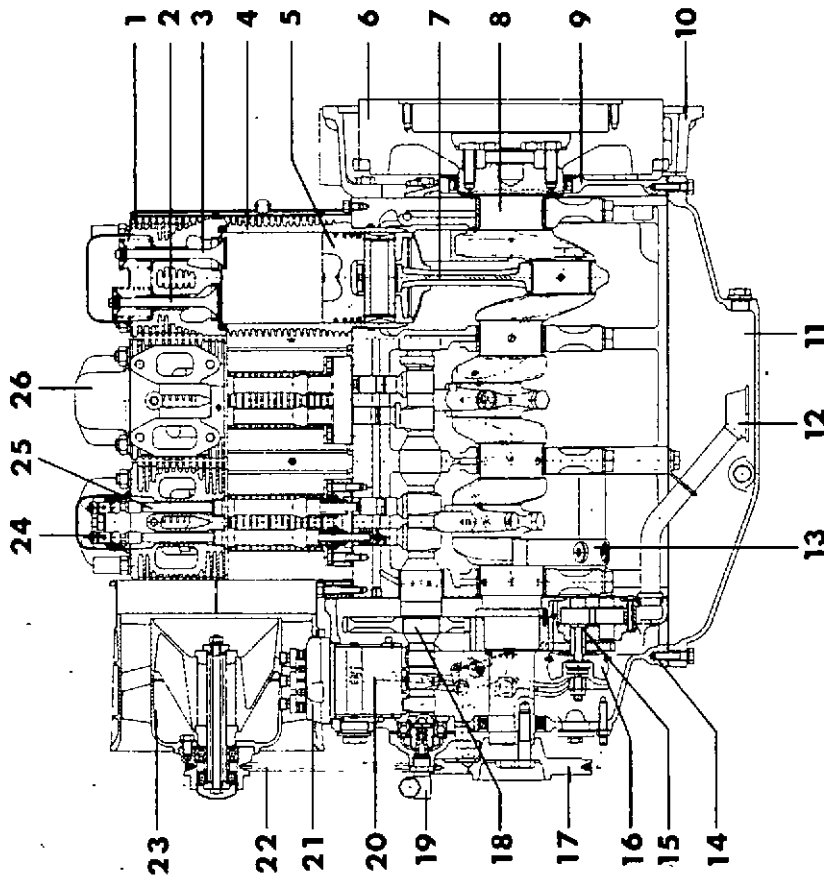

- 1 Cylinder head
- 2 Inlet valve
- 3 Exhaust valve
- 4 Finned cylinder
- 5 Piston
- 6 Flywheel
- 7 Connecting rod
- 8 Crankshaft
- 9 Front wall cover (flywheel end)
- 10 Flywheel housing
- 11 Oil pan
- 12 Lube oil suction line
- 13 Counterweight
- 14 Front wall cover (timing gear end)
- 15 Lube oil pump
- 16 Governor
- 17 V-belt pulley
- 18 Camshaft
- 19 Angular gear for rev counter
- 20 Lever for injection regulation
- 21 Injection pump
- 22 V-belt
- 23 Cooling air fan
- 24 Rocker arm
- 25 Pushrod
- 26 Cylinder head cover

WIRING DIAGRAM FOR D302 SERIES ENGINES EQUIPPED WITH FEMSA GENERATOR

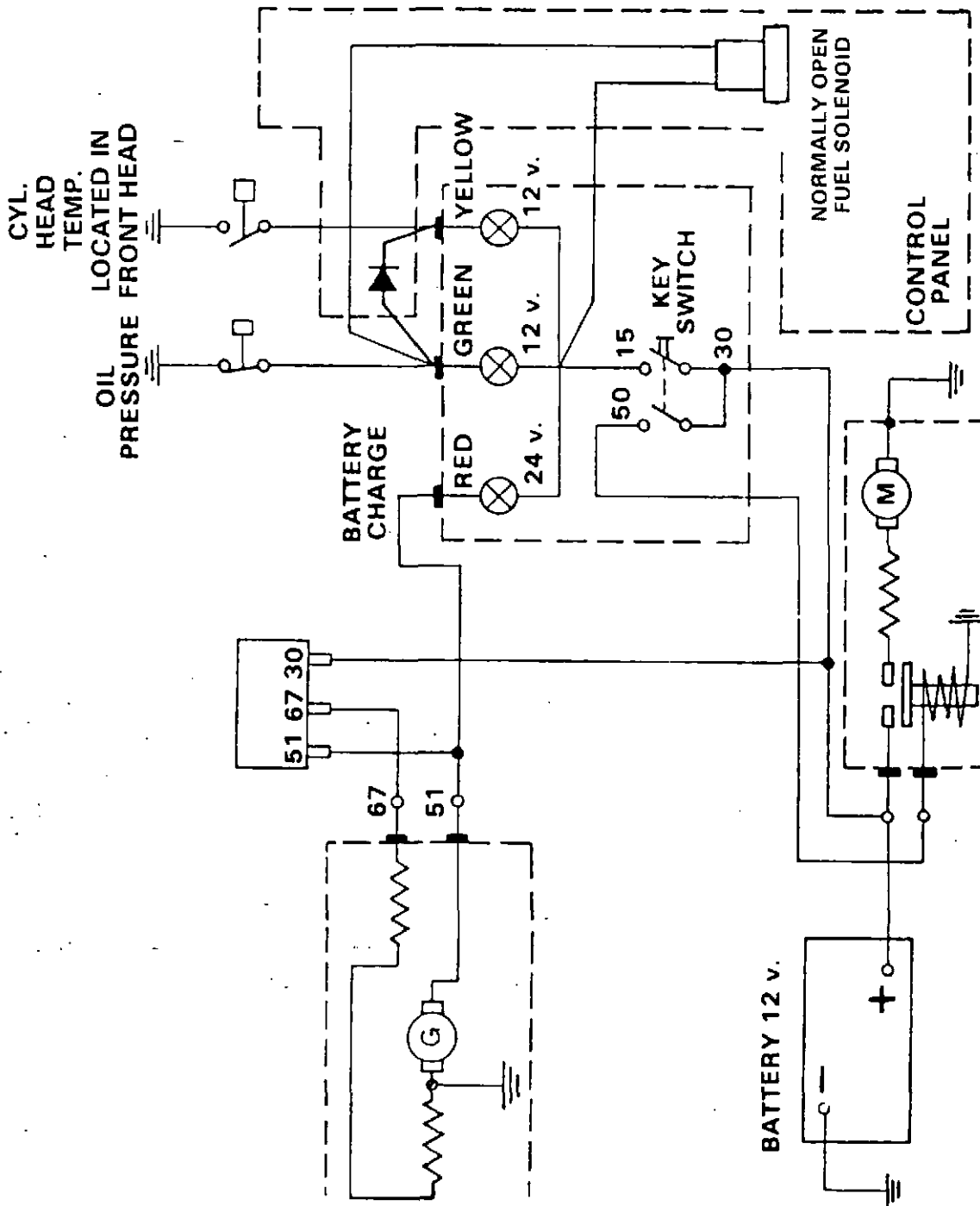

WIRING DIAGRAM WITH MOTOROLA ALTERNATOR, SMALL PANEL
 WITH INDICATOR LIGHTS.
 FUEL SOLENOID SHUT DOWN OPTIONAL.
 BELT BREAKAGE RELAY OPTIONAL.

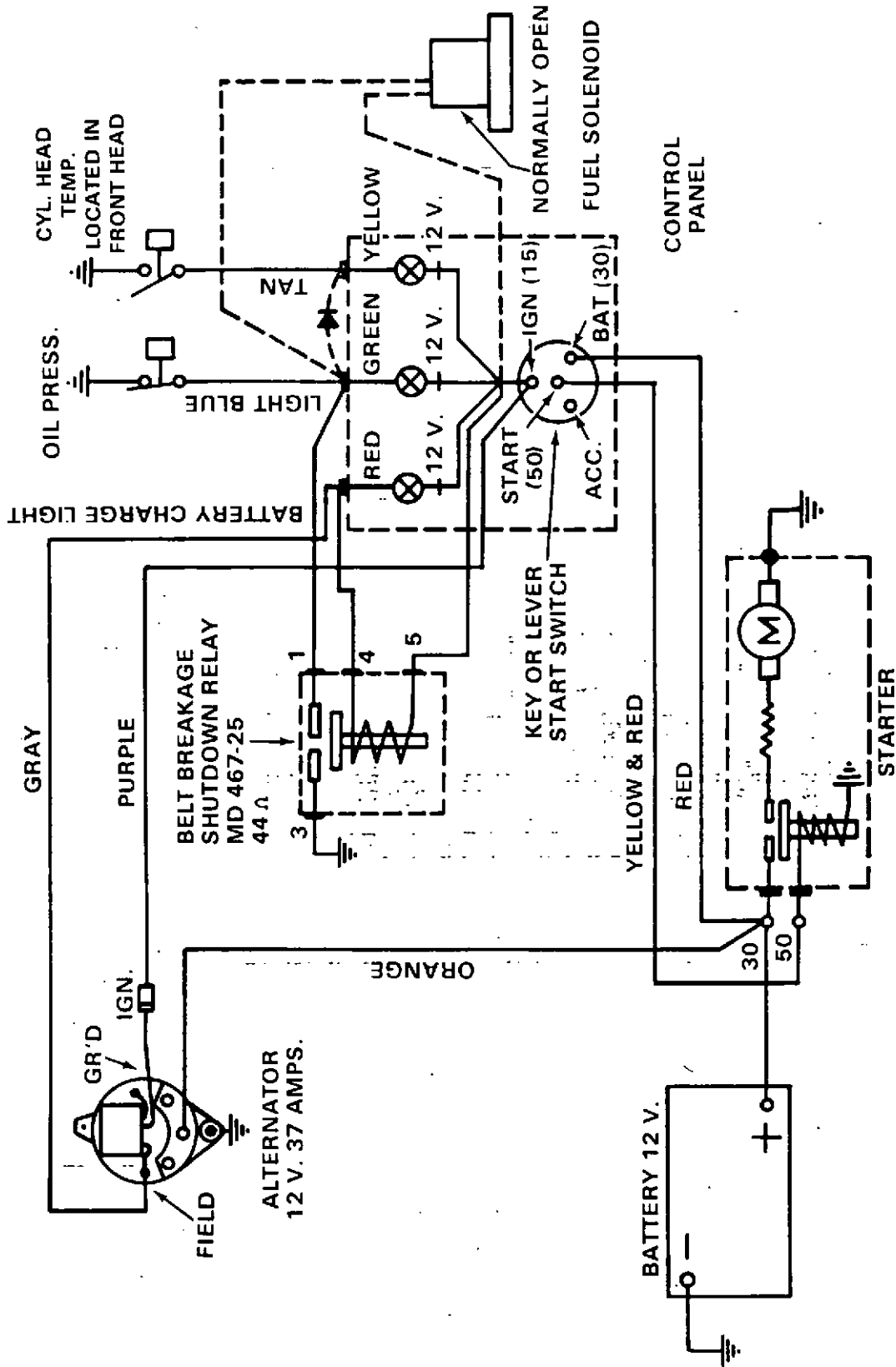

WIRING DIAGRAM WITH MOTOROLA ALTERNATOR, SEMI-AUTOMATIC SWITCH GAUGE PANEL WITH BELT BREAKAGE RELAY (OPTIONAL)

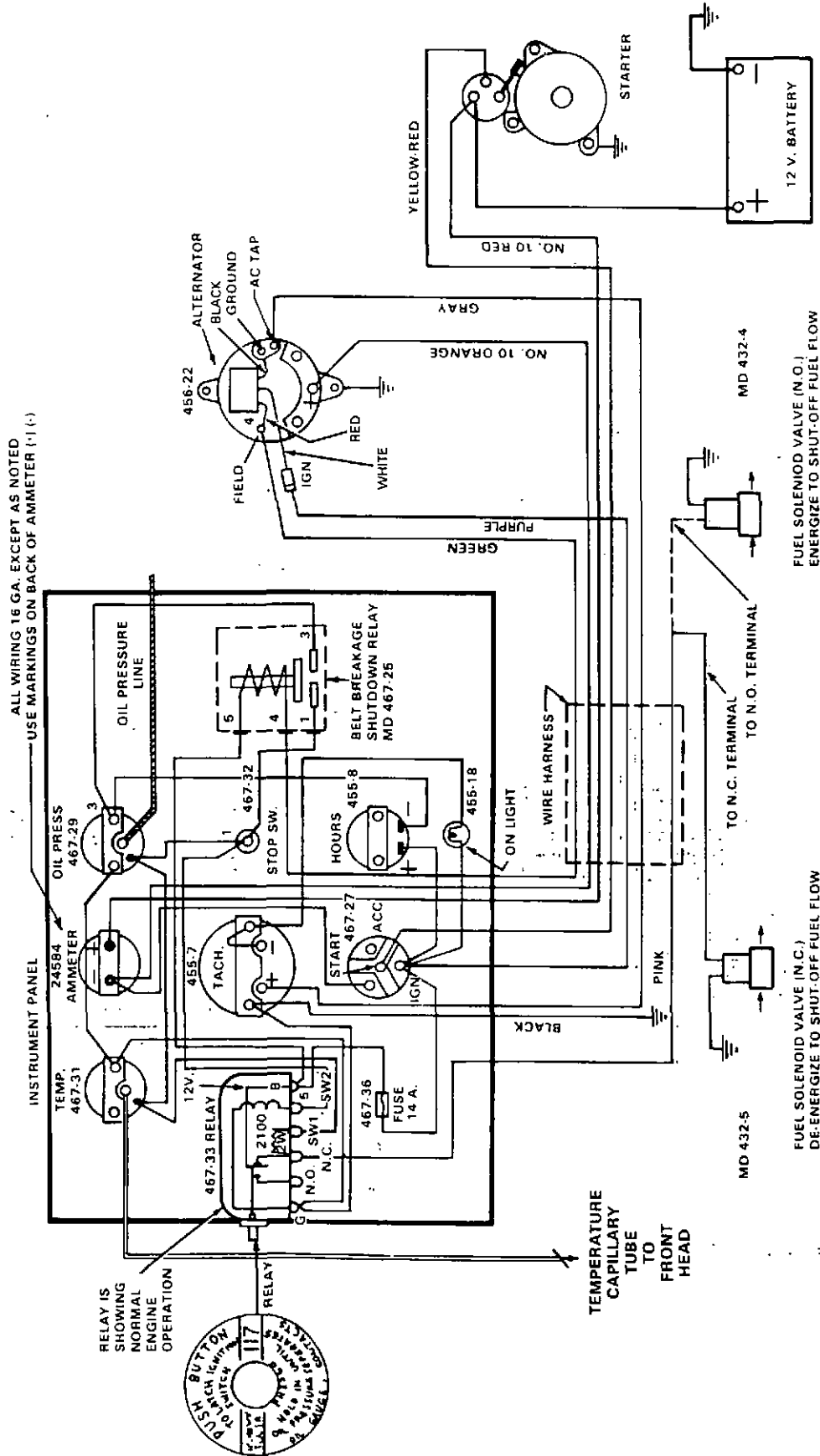

ALTERNATOR
MD 456-22-1

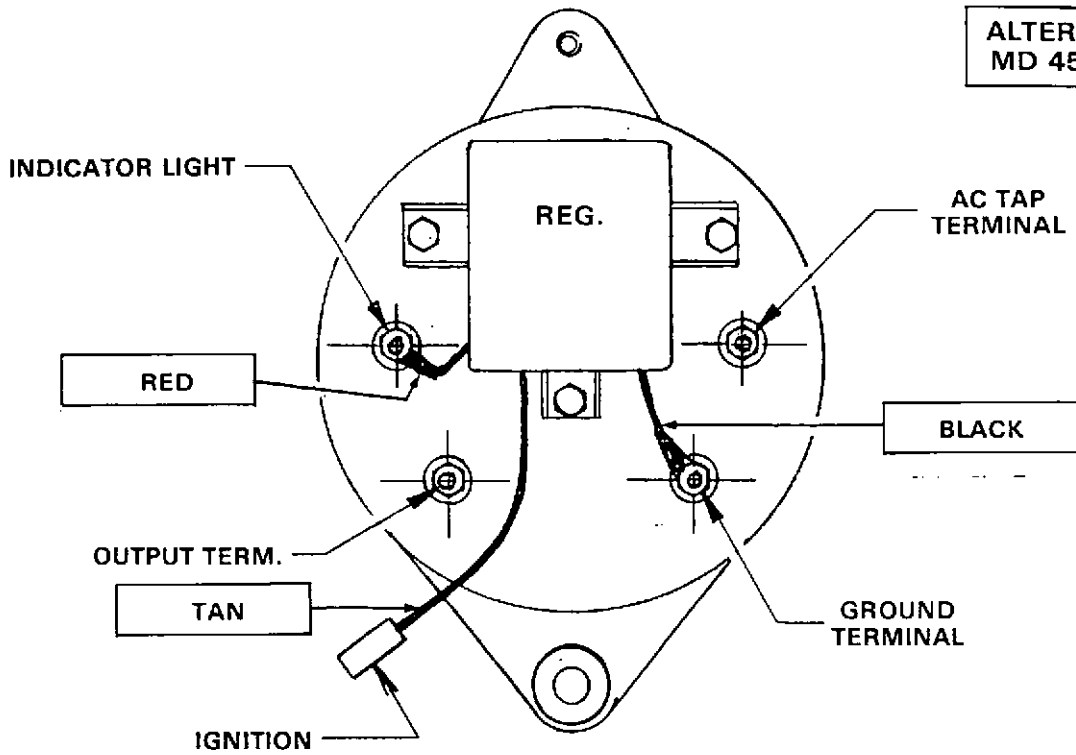

CURRENT

ALTERNATOR
MD 456-22

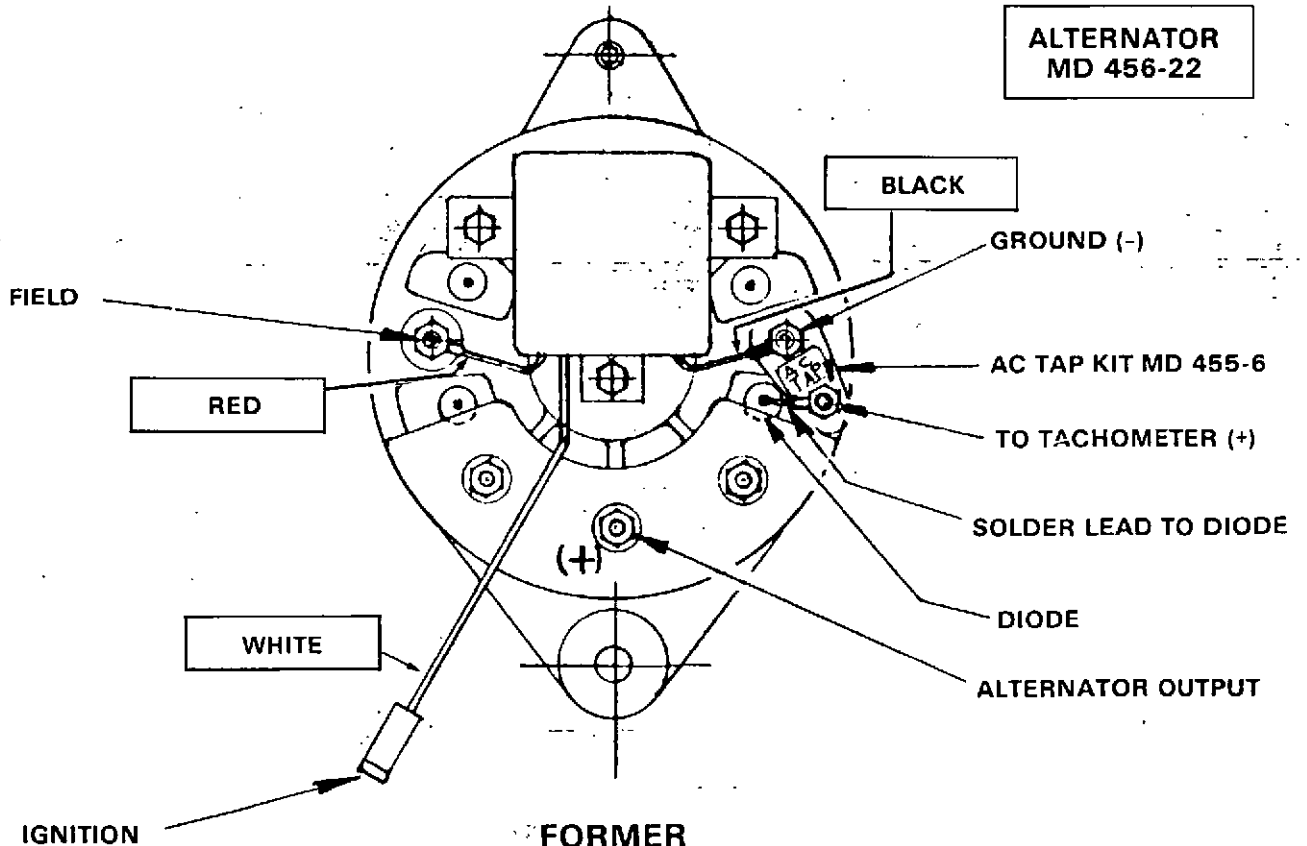

FORMER

Motorola Alternator Wiring

Raising low oil pressure signal on D302 Series Engines equipped with semi-automatic shutdown.

There are two (2) normally closed oil pressure switches available for the D302 Series Engines equipped with the small indicator light panel.

PART NUMBER	IDENTIFICATION ON SWITCH*	OPENING PRESSURE
6.0578.20.0.5080	D80151 or D81121	8 - 12 p.s.i.
6.0578.20.1.0005	D81124	28 - 34 p.s.i.

*The number shown is for U.S.A. made switches. This number is stamped on the bottom of the switch.

The standard switch used with this panel is the 8 - 12 p.s.i. switch. For applications where the engine is unattended or an engine that operates at a constant speed, it is recommended that the 8 - 12 p.s.i. switch be replaced with the 28 - 34 p.s.i. switch.

For engines equipped with the Frank W. Murphy switch gauge panel, insert a 1/16" Allen wrench into the adjusting screw on the face of the oil pressure gauge and readjust so that the needle will read 30 p.s.i.

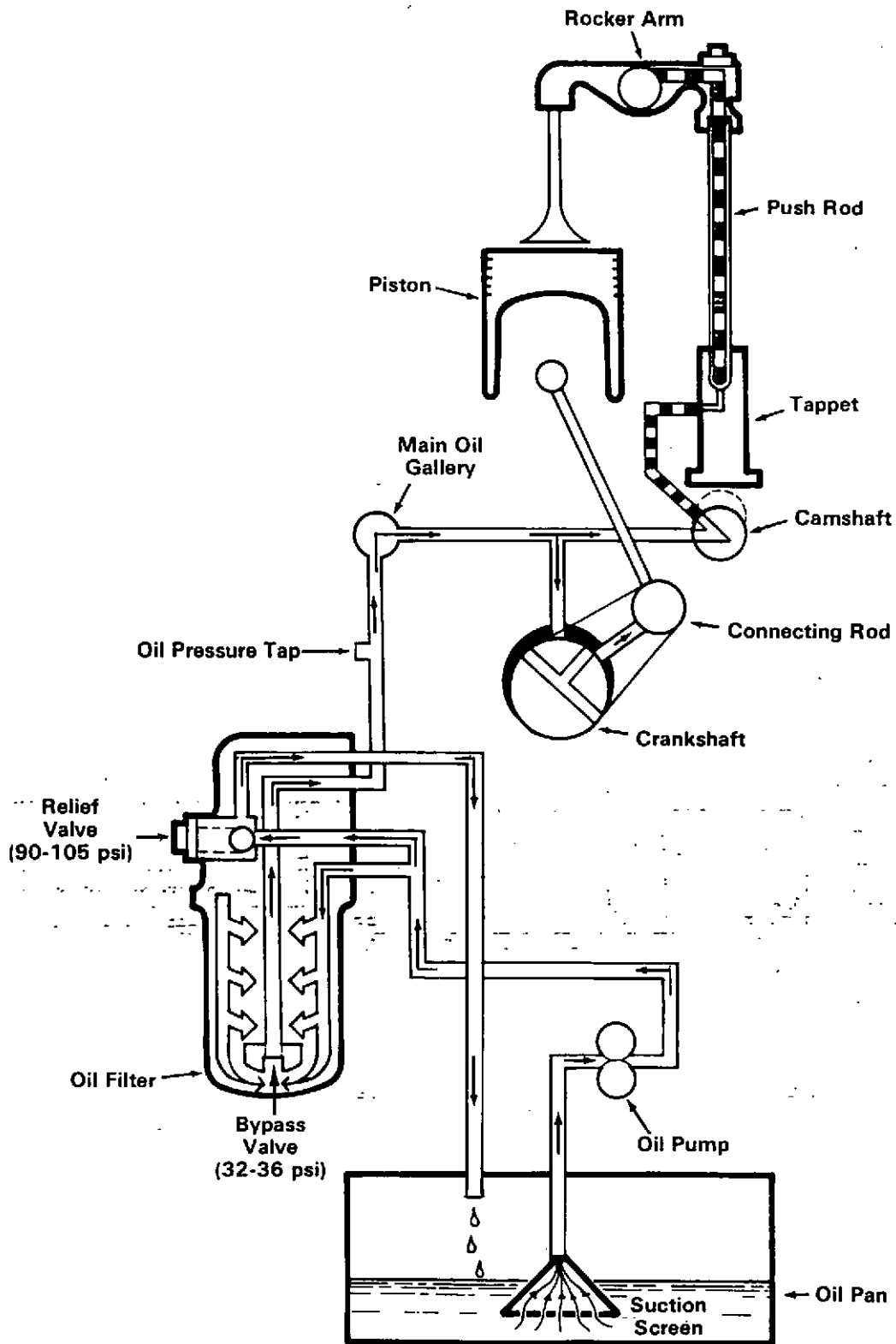

LUBRICATION OIL FLOW
D302-1 and D302-2

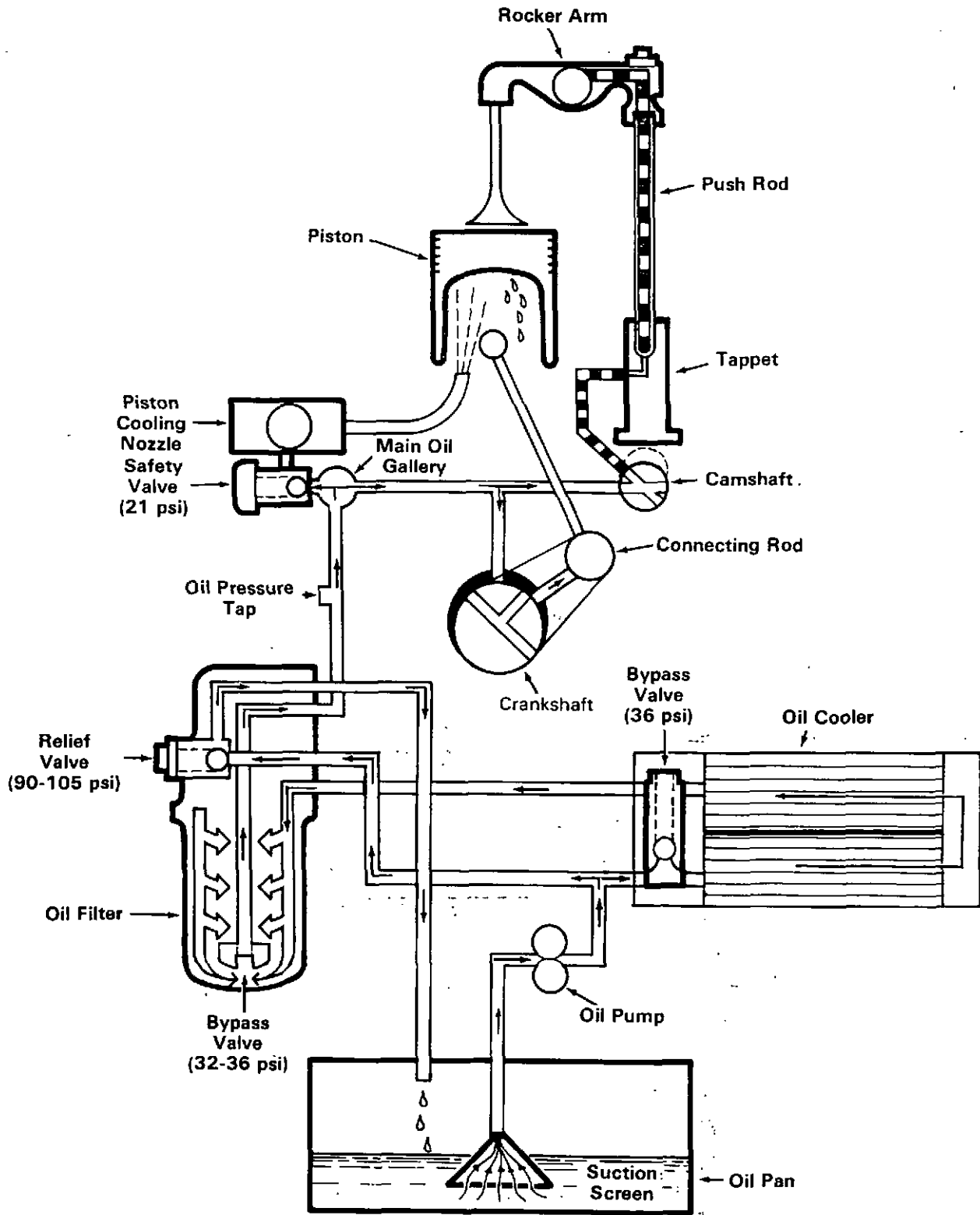

**LUBRICATION OIL FLOW
D302-3**

Cooling Air Flow

The heat resulting from combustion in the engine cannot be fully converted into kinetic energy, part has to be absorbed by the cooling air. The flywheel blower or axial blower forces the cooling air into the cooling air guide and through the fins of the cylinder head and finned cylinder.

When assembling the engine, care must be taken to ensure that the hot exhaust air can leave the engine without obstruction, otherwise a thermal short-circuit will be formed in which the cooling air is heated in continuous circulation resulting in the engine overheating.

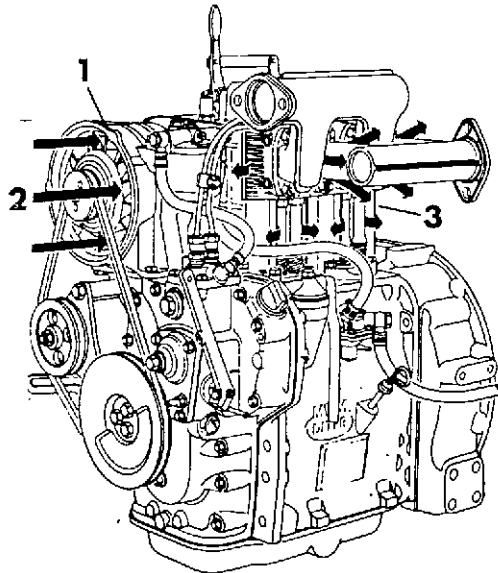

D 302 - 2

- 1 Axial blower
- 2 Cooling air inlet
- 3 Cooling air outlet

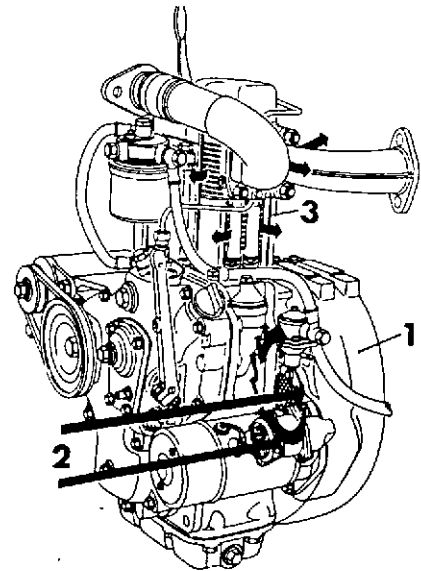

D 302 - 1

- 1 Flywheel blower
- 2 Cooling air inlet
- 3 Cooling air outlet

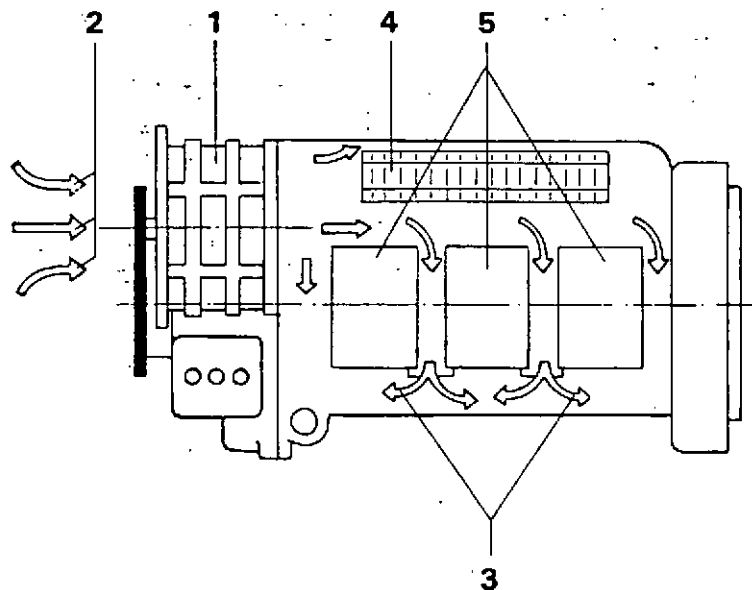

D 302 - 3

- 1 Axial blower
- 2 Cooling air inlet
- 3 Cooling air outlet
- 4 Oil cooler (D302-3 only)
- 5 Finned cylinders and cylinder heads

Fuel Flow

Fuel is drawn from the fuel tank by the fuel feed pump. The fuel feed pump then directs the flow of fuel under low pressure through the fuel filter to the injection pump. The injection pump then sends under high pressure a timed, metered amount of fuel through individual injection lines to

the injection nozzles. The injection nozzles then atomize this fuel as it is injected into the cylinder. A small amount of fuel is allowed to leak from the injection nozzles; it is collected by the leak-off line which will return this unused fuel to the supply tank.

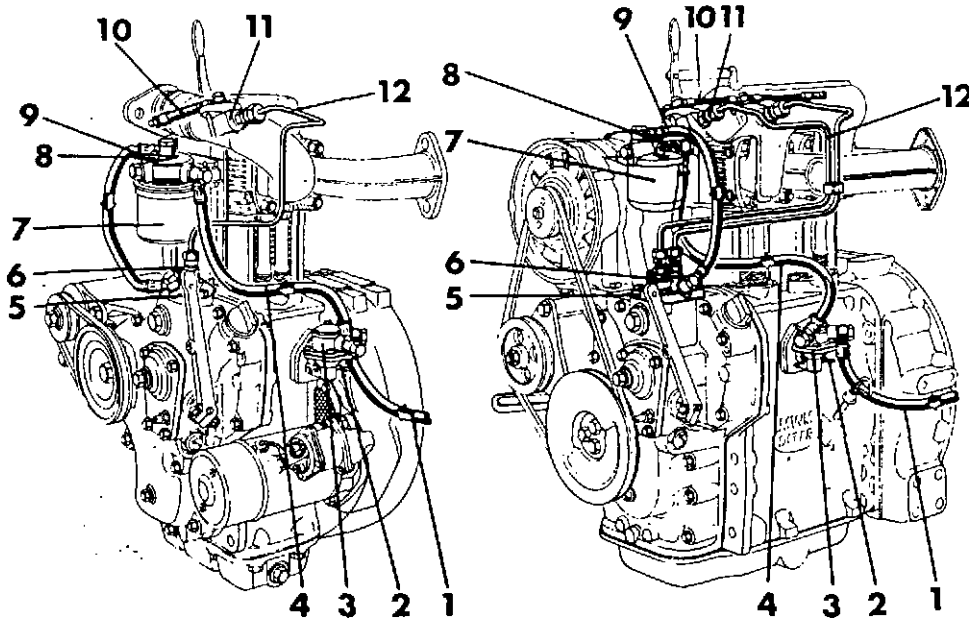

D 302 - 1

D 302 - 2 & 3

- 1 Fuel suction line from fuel tank to feed pump
- 2 Primer lever
- 3 Diaphragm feed pump
- 4 Fuel line from feed pump to fuel filter
- 5 Injection pump
- 6 Actuator for additional fuel on starting

- 7 Fuel filter
- 8 Fuel filter breather
- 9 Fuel line from fuel filter to injection pump
- 10 Leakoff line to fuel tank
- 11 Injection nozzle
- 12 Fuel delivery line

- The connections for the suction and delivery lines differ from pump to pump depending on the manufacture and are marked on the housing by cast-on arrows. (At the delivery port, the arrow points away from the pump.)

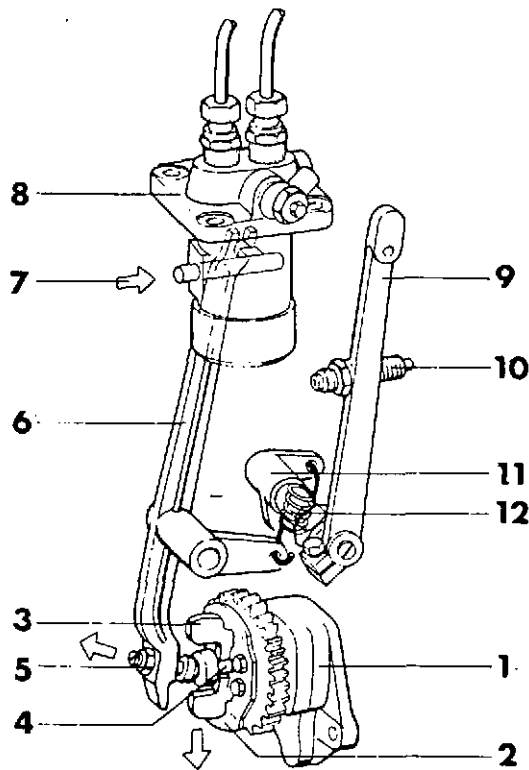

VERSION I & II TYPE GOVERNOR
(manual start-fuel)

- 1 Oil pump
- 2 Flyweight carrier
- 3 Flyweights
- 4 Riser button
- 5 Lever adjusting screw
- 6 Governor lever
- 7 Injection pump rack

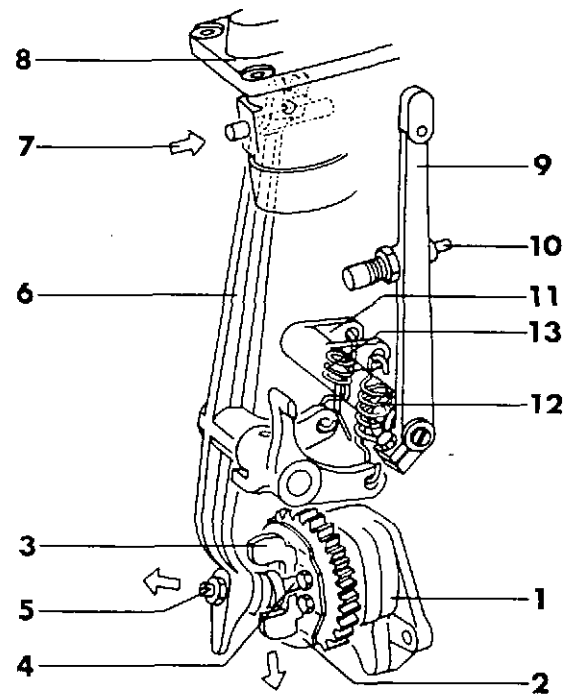

VERSION III TYPE GOVERNOR
(automatic start-fuel)

- 8 Injection pump
- 9 Throttle lever
- 10 Idle speed adjusting screw
- 11 Spring lever
- 12 Governor speed control spring
- 13 Starting fuel delivery spring
(Version III governor only)

GOVERNOR OPERATION

The D 302 Series governor is of the variable speed type. With the throttle lever fixed in a specific speed setting, the governor will maintain a reasonably constant speed regardless of load fluctuations, provided the load is within the power range of the engine. This governor is a speed sensing device that has two operating or controlling forces: spring force and centrifugal flyweight force. The spring force (or tension) is determined by the position of the throttle lever. Centrifugal flyweight force is developed by the speed of the oil pump which is driven by the crankshaft; therefore, weight force is determined by engine speed.

With the throttle lever fixed at a specific speed setting (e.g., 1860 rpm) with no load, the flyweights counteract spring tension to keep the injection pump rack in a minimum fuel position (enough to keep the engine rpm at 1860 no-load). If a load was introduced to the engine, rpm will drop (e.g., 1800 rpm) and so will centrifugal flyweight force. Spring tension will then be allowed to pull the rack to a more fuel position which will prevent the engine from underspeeding. If a load were removed from the engine,

rpm will increase (e.g., 1860 rpm) and so will centrifugal flyweight force. This increase in weight force will overcome spring force to move the rack to a lesser fuel position to prevent the engine from overspeeding.

To shut the engine off, moving the throttle lever to the off position will remove spring tension, which will allow centrifugal flyweight force to move the rack to the no-fuel position. To start the engine, positioning the throttle in some speed setting will develop spring tension in the governor and, with the engine stopped, there is no flyweight force, and therefore the rack will be in the full-fuel position. A note to mention here, some injection pumps (see Versions I and II governors, section 6-12) have a "start-fuel" button which, when activated, will retard injection timing by 12° and also give a larger quantity of fuel to aid in easier starting. (Version III governors' injection pumps do not have "start-fuel" buttons because this "start-fuel" feature is automatic.)

5. Go/no go dimensions on wearing parts

5-1. General

- After having dismantled the engine, carefully clean and dry all component parts.
- All parts subject to wear and tear after a certain time are listed in the following along with the dimensions when new and their go/no go dimensions.
- Carefully gauge the items and check the surface (micrometer, measuring temperature: 20°C (68°F)).
- If the measuring and test results show values exceeding or reaching no-go dimensions, the parts concerned must be replaced.

SYMBOL	RMS FINISH	STONE GRIT
▽	250	80
▽▽	63	150
▽▽▽	16	400
▽▽▽▽	4	600

GO/NO GO DIMENSIONS ARE GIVEN FOR THE FOLLOWING PARTS:

- | | |
|--|---|
| 1. Crankshaft (1-cyl.) | 24. Valve seating insert, inlet and exhaust premachined |
| 2. Crankshaft (2 & 3 cyl.) | 25. Valve guide |
| 3. Gear wheel for crankshaft (1-cyl.) | 26. Rocker arm bracket |
| 4. Gear wheel for crankshaft (2 & 3 cyl.) | 27. Rocker arm |
| 5. Bearing ring, gear end (1-cyl.) | 28. Camshaft (1-cyl.) |
| 6. Bearing ring, crank web end (1-cyl.) | 29. Camshaft (2 & 3 cyl.) |
| 7. Bearing bush for crankshaft (1-cyl.) | 30. Camshaft bore in crankcase (1-cyl.) |
| 8. Thrust bearing shell (2 & 3 cyl.) | 31. Camshaft bore in crankcase (2 & 3 cyl.) |
| 9. Main bearing shell (2 & 3 cyl.) | 32. Mushroom-head tappet |
| 10. Rod bearing shell | 33. Gear wheel for camshaft |
| 11. Bearing bush for camshaft (1-cyl.) | 34. Injection pump (1 and 2 cyl.) |
| 12. Bearing bush for camshaft (2 & 3 cyl.) | 35. Injection governing lever |
| 13. Bearing bush for counterweight (1-cyl.) | 36. Eccentric disc for governing lever (Version I) |
| 14. Groove ball bearing for counterweight in front wall cover (1-cyl.) | 37. Governor weight |
| 15. Groove ball bearing for camshaft in front wall cover | 38. Governor weight bracket |
| 16. Counterweight shaft (1-cyl. only) | 39. Shaft with gear wheel for oil pump with governor |
| 17. Gear wheel for counterweight (1-cyl. only) | 40. Governor riser shaft |
| 18. Piston compl. | 41. Decompression shaft |
| 18a. Piston identification | 42. V-belt pulley for belt tensioner |
| 19. Finned cylinder | 43. Ring gear on flywheel (1, 2 and 3 cyl.) |
| 20. Piston pin | 44. Cooling air blower (2 cyl.) |
| 21. Connecting rod | 45. Cooling air blower (3 cyl.) |
| 22. Valve depression | |
| 23. Inlet and exhaust valve cones | |
- (These numbers are the item numbers given in the first column under section 5.2.)

5.2.1 - 5.2.2

Table for wear parts limit dimensions

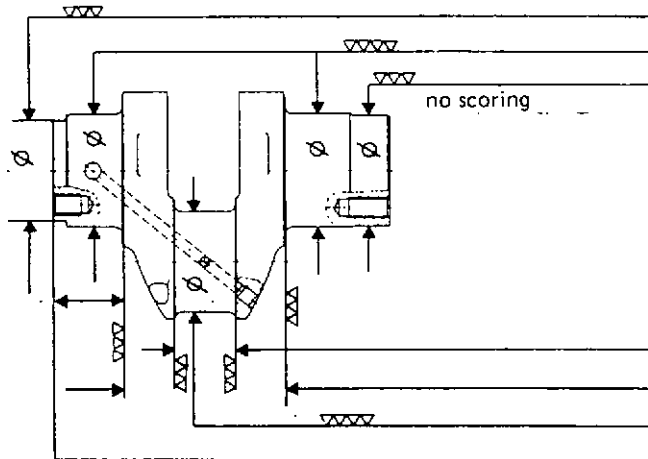
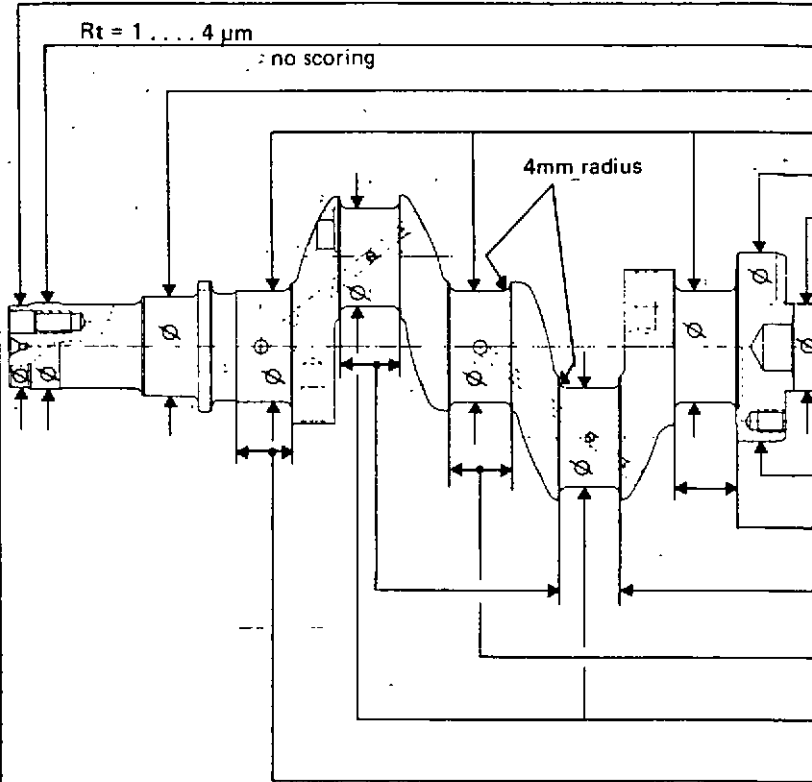
No.	Description	Dimensions				
		New state		wear limit		
		max mm	min mm	max mm		
1	Crankshaft (1 cylinder)  <p>no scoring</p>	58,000	57,981	57,950		
		64,970	64,951	57,940		
		63,990	63,971	63,950		
		35,100	35,000	35,150		
		94,200	93,800	93,600		
		57,970	57,951	57,940		
		40,00	39,97	40,20		
		Refurbishing dimensions see Section 5.3.1.				
		2	Crankshaft (2 & 3 cylinder)  <p>Rt = 1 4 µm</p> <p>no scoring</p> <p>4mm radius</p>	47,975	47,950	47,900
				49,970	49,940	49,900
58,060	58,041			58,000		
64,970	64,951			64,940		
110,000	109,946			109,920		
51,955	51,925			51,900		
no scoring						
36,050	36,000			36,070		
35,100	35,000			35,150		
36,100	36,000			36,150		
57,970	57,951			57,940		
32,000	31,500			32,500		
To recondition see refurbishing grades.						

5.2.3 - 5.2.6

Table for wear parts limit dimensions

No.	Description	Dimensions		
		New state max mm	min mm	wear limit max mm
3	Gear wheel for crankshaft (1-cylinder) 	58,019	58,000	Tooth edges smooth, no scoring and wear
4	Gear wheel for crankshaft (2 & 3 cylinder) 	58,019	58,000	Tooth edges smooth, no scoring and wear Heat gear to max. 220°C (425°F) to obtain shrink-fit.
5	Bearing ring, gear end (1-cylinder) 	58,076	58,036	2,95
		3,00	2,98	renew if scored
6	Bearing ring, crank web end (1-cylinder) 	85,964	85,910	2,95
		3,00	2,98	renew if scored

Table for wear parts limit dimensions

No.	Description	Dimensions		
		New state		wear limit max mm
		max mm	min mm	
7	Bearing bush for crankshaft (1-cylinder) 	3,485 72,060	3,470 72,035	Both shell bearings or bearing bushes will have to be renewed when the galvanically applied third coat "S" wears off indicated by shiny bronze/gold contact pattern at points O and U, and or when scoring appears around entire circumference. Bearing is a press fit. Use tool M1016 to remove and install.
8	Thrust bearing shell (2 & 3 cylinder) 	2,987	2,975	Important: There is no point in fitting new shell bearings or bearing bushes on shaft journals with no go dimensions. See refurbishing grades
9	Main bearing shell (2 & 3 cylinder) 	2,987	2,975	
10	Rod bearing shell 	1,992	1,980	

Table for wear parts limit dimensions

No.	Description	Dimensions		
		New state		wear limit
		max mm	min mm	max mm
11	Bearing bush for camshaft (1-cylinder)	2,005 43,025	1,990 43,000	1,960 43,060
		Bushing is a press fit. Use tool M1016 to remove and install.		Measured in place. See refurbishing grades.
12	Bearing bush for camshaft (2 & 3 cylinder)	2,005 43,025	1,990 43,000	1,960 43,060
		Bushing is a press fit. Use tool M1016 to remove and install.		Measured in place. See refurbishing grades.
13	Bearing bush for counterweight (1-cylinder)	32,030	32,005	32,100
		Bushing is a press fit. Use tool M1016 to remove and install.		Measured in place.
14	Groove ball bearing for counterweight in front wall cover (1 cylinder)			
				Renew ball bearing if showing appreciable play.
15	Groove ball bearing for camshaft in front wall cover			
				

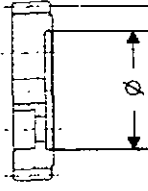
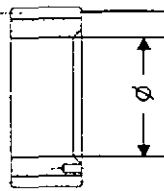
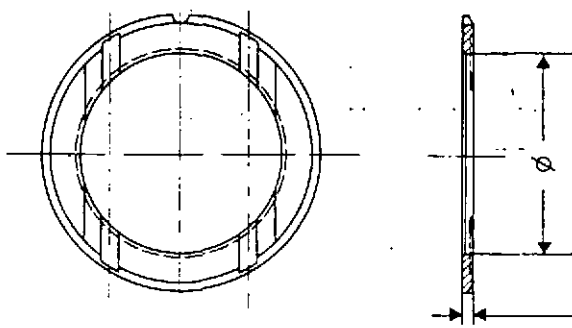
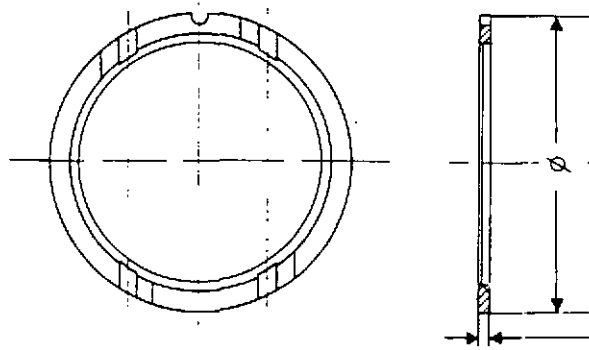

5.2.16 - 5.2.17

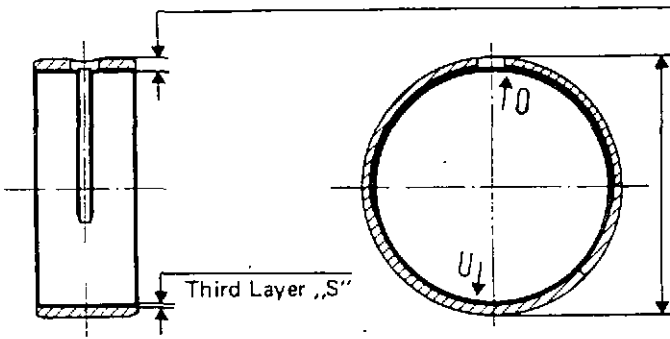
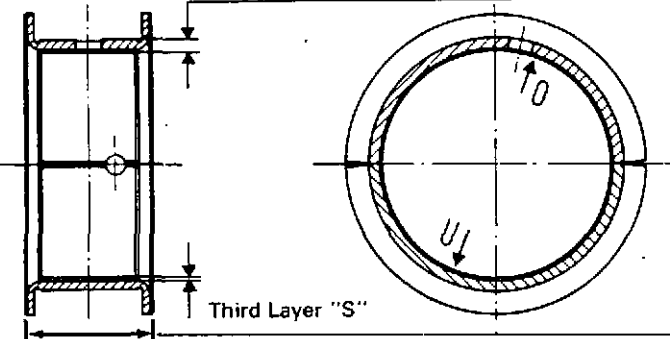
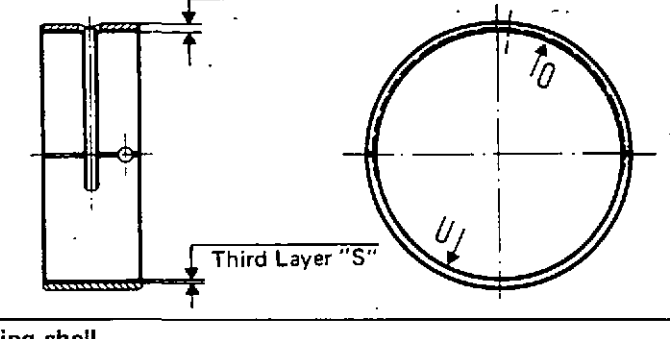
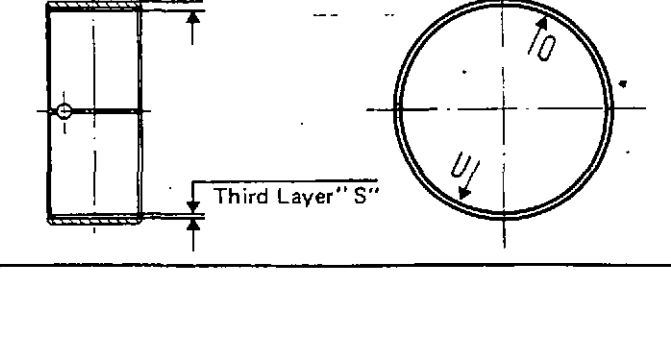
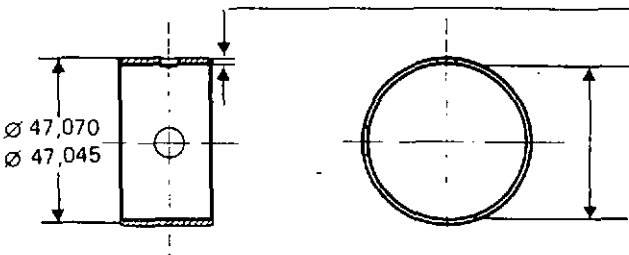
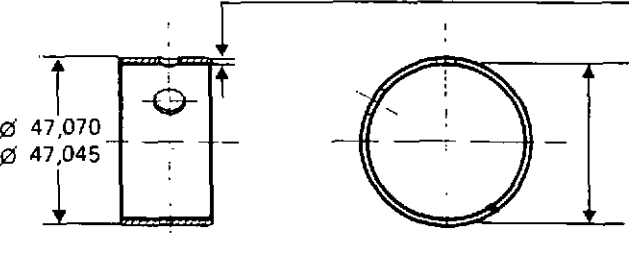
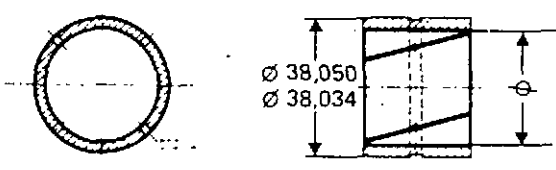
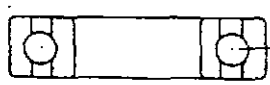
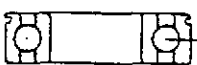
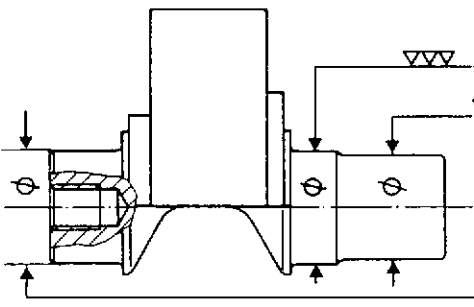
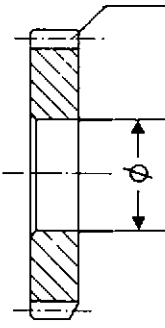
Table for wear parts limit dimensions

No.	Description	Dimensions		
		New state		wear limit
		max mm	min mm	max mm
16	Counterweight shaft (1-cylinder only)			
		34,065	34,049	31,900
		31,975	31,950	
		34,975	34,950	Groove ball bearing seat
17	Gear wheel for counterweight (1-cylinder only)			
		34,016	34,000	Tooth edges smooth no scoring and wear. Press fit.
		Heat gear to approx. 220°C (425°F) for shrink-fit.		

5.2.18

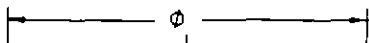
Table for wear parts limit dimensions

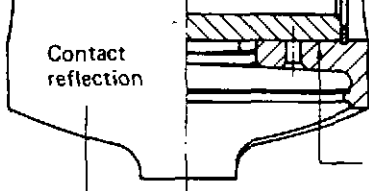
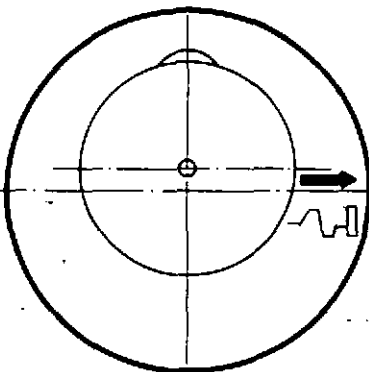
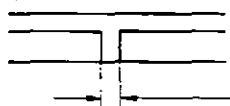
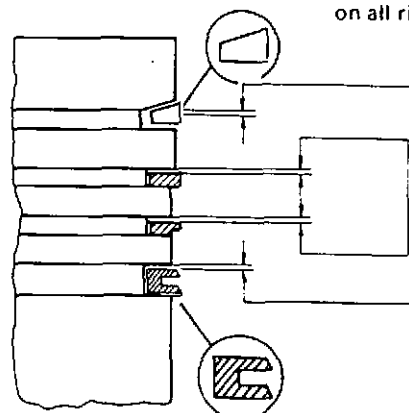
No.	Description	Dimensions			
		New state max mm	min mm	wear limit max mm	
18	Piston compl.		94,560	94,540	94,50
			3,040 3,080	3,020 3,060	3,050 3,120
			5,070	5,050	5,110
			32,006	32,002	32,015
				Renew if longitudinally scored	
		.65	.40	2 mm	
				0,25 0,20 0,15	
		Tops of rings will have "T" or TØP Butt clearance caused by piston ring wear and wear of crosshatched cylinder surface.			

5.2.18a - 5.2.19

Table for wear parts limit dimensions

No.	Description	Dimensions		
		New state		wear limit
		max mm	min mm	max mm
18a	<p>Piston identification</p> <p>When converting an engine from one piston to another, include the correct fuel injection nozzles. See technical data section under "Fuel System" for injection nozzle I.D. number and opening pressures. This applies only to 2 and 3 cylinder engines. Do not use the high output piston and corresponding fuel injection nozzle in the D302-1 engine.</p>			
19	<p>Finned cylinder</p>	<p>Taper</p> <p>Out-of-Round</p>	<p>.025</p> <p>.025</p>	
		95,022	95,000	95,250
		87	69	<p>Rehone if scored: longitudinal scores exceeding 0.05 mm in depth. Honing must maintain a 120° cross hatch. Use stones of 150 grit.</p>
<p>To recondition see refurbishing grades, section 5.3.4.</p>				

5.2.20 - 5.2.21

Table for wear parts limit dimensions

No.	Description	Dimensions		
		New state max mm	min mm	wear limit max mm
20	Piston pin 	32,000	31,994	31,990
				Renew if scored.
21	Connecting rod 	32,080	32,030	32,150
		62,019	62,000	No clearance.
		1.5	1.3	

Table for wear parts limit dimensions

No.	Description	Dimensions		
		New state		wear limit
		max mm	min mm	max mm
22	Valve depression			
		1,45	1,00	1,80
23	Inlet and exhaust valve cones			
		8,970	8,952	8,949
		2,450	2,100	Regrinding tolerance 3,100

Table for wear parts limit dimensions

No.	Description	Dimensions		
		New state		wear limit
		max mm	min mm	max mm
24	Valve seating insert, inlet premachined 	1,8	1,35	2,5
	Valve seating insert, exhaust premachined 	1,8	1,35	2,5
		To recondition see refurbishing grades, section 5.3.5.		
25	Valve guide 	9,028	9,013	9,060
		15,047	15,032	Press fit
		To recondition see refurbishing grades, section 5.3.5.		

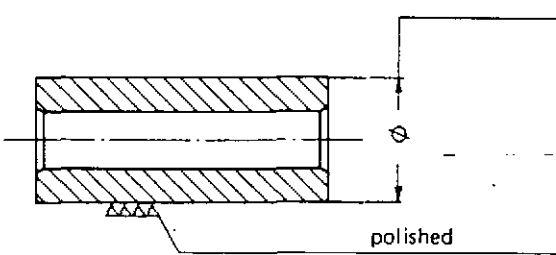
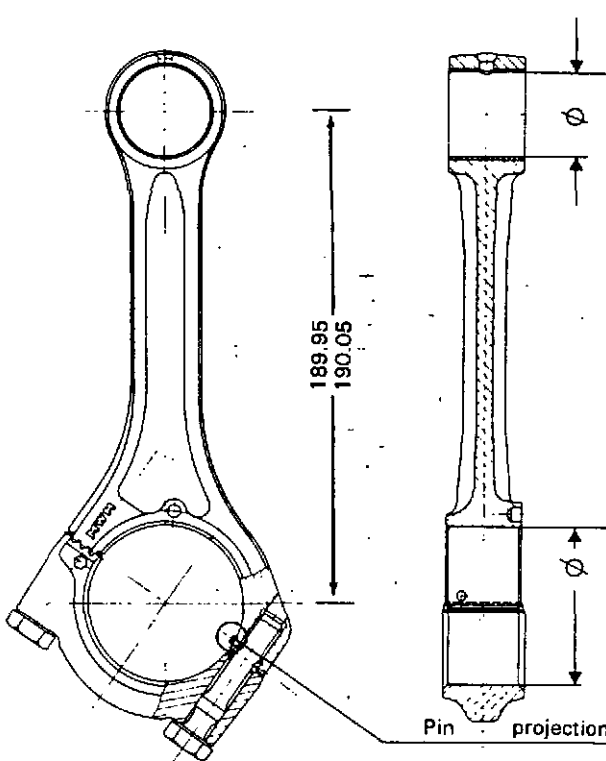
Table for wear parts limit dimensions

No.	Description	Dimensions		
		New state max mm	min mm	wear limit max mm
26	Rocker arm bracket 	15,984	15,966	15,950
27	Rocker arm  h = 14.5 mm (.571") cast standard h = 12.0 mm (.472") machined for compression release (intake rocker only)	16,018	16,000	16,030
28	Camshaft (1-cylinder) 	24,993 38,059 42,960 29,960	24,980 38,043 42,940 29,940	Groove ball bearing seat 38,020 42,920 29,920
		To recondition see refurbishing grades, section 5.3.2.		Renew if scored
29	Camshaft (2 & 3 cylinder) 	24,993 38,059 42,960	24,980 38,043 42,940	Groove ball bearing seat 38,020 42,920
		To recondition see refurbishing grades, section 5.3.2.		Renew if scored.

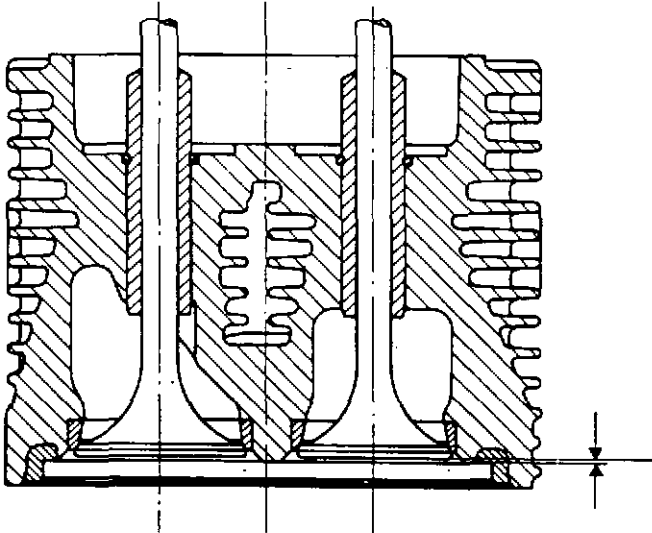
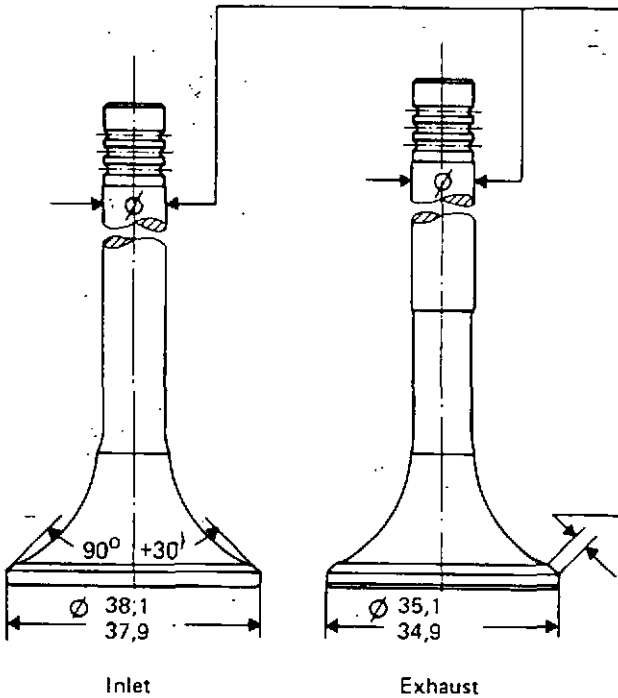
Table for wear parts limit dimensions

No.	Description	Dimensions			
		New state		wear limit	
		max mm	min mm	max mm	
30	Camshaft bore in crankcase (1-cylinder)		18,015	18,000	18,020
			43,025	43,000	43,050
			30,025	30,000	30,050
			To recondition see refurbishing grades, section 5.3.3.		
31	Camshaft bore in crankcase (2 & 3 cylinder)		18,015	18,000	18,020
			43,025	43,000	43,050
			To recondition see refurbishing grades, section 5.3.3.		
32	Mushroom-head tappet		17,994	17,983	17,975
			Renew if scored.		

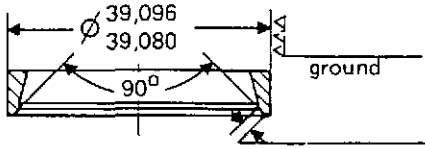
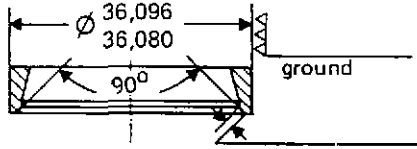
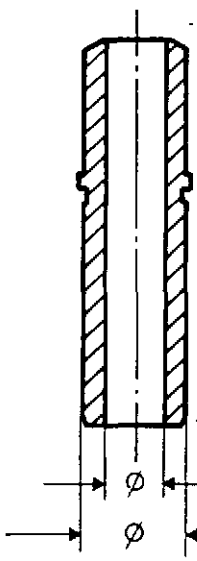
Table for wear parts limit dimensions

No.	Description	Dimensions		
		New state		wear limit
		max mm	min mm	max mm
33	Gear wheel for camshaft 	38,016	38,000	Renew if scored Press fit
34	Injection pump (1 and 2 cylinder) 			Renew if scores and/or clearance. Shims for start of delivery and pre-stroke adjustment.

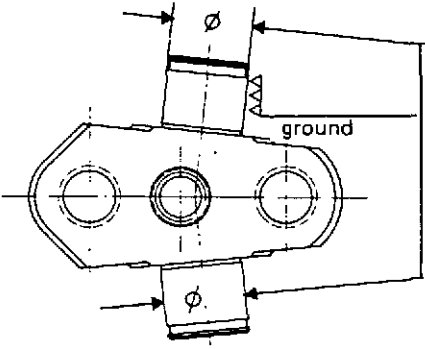
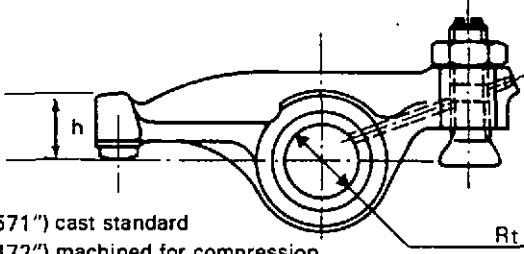
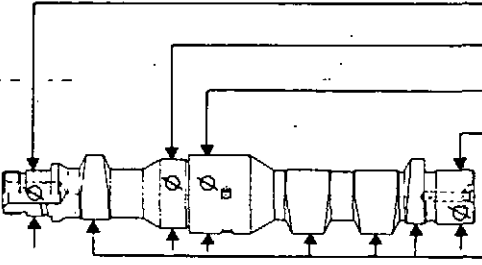
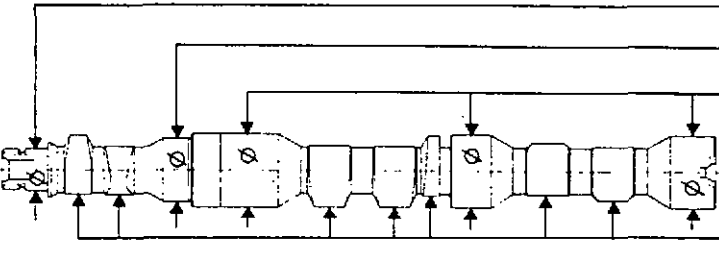
Table for wear parts limit dimensions

No.	Description	Dimensions		
		New state		wear limit
		max mm	min mm	max mm
35	Injection governing lever 	5,018	5,000	5,030
		Version I & II 12,013	12,000	12,030
	Version III 13,013	13,000	13,030	
				Renew if worn
36	Eccentric disc for governing lever (Version I) 	11,987	11,972	11,950
37	Governor weight  Version I & II 8mm thick Version III 16mm thick			Renew if worn

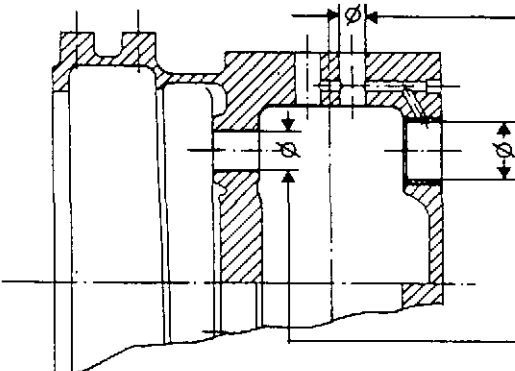
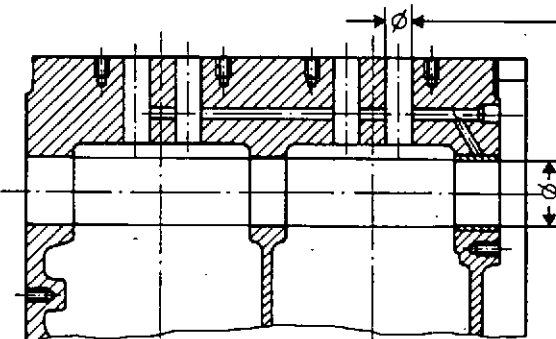
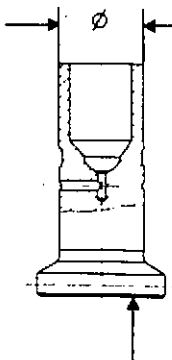
Table for wear parts limit dimensions

No.	Description	Dimensions		
		New state		wear limit max mm
		max mm	min mm	
38	Governor weight bracket 	Version I & II		8,500
		8,480	8,300	
		Version III		16,500
		16,400	16,200	
		13,180	13,000	
39	Shaft with spur gear for oil pump with governor 	Tooth edges smooth, no scoring or wear		15,660
		15,684	15,673	
		7,015		7,030
		7,000		
40	Governor riser shaft 	6,987	6,972	6,960

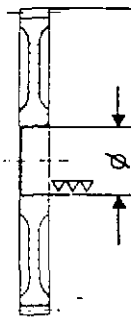
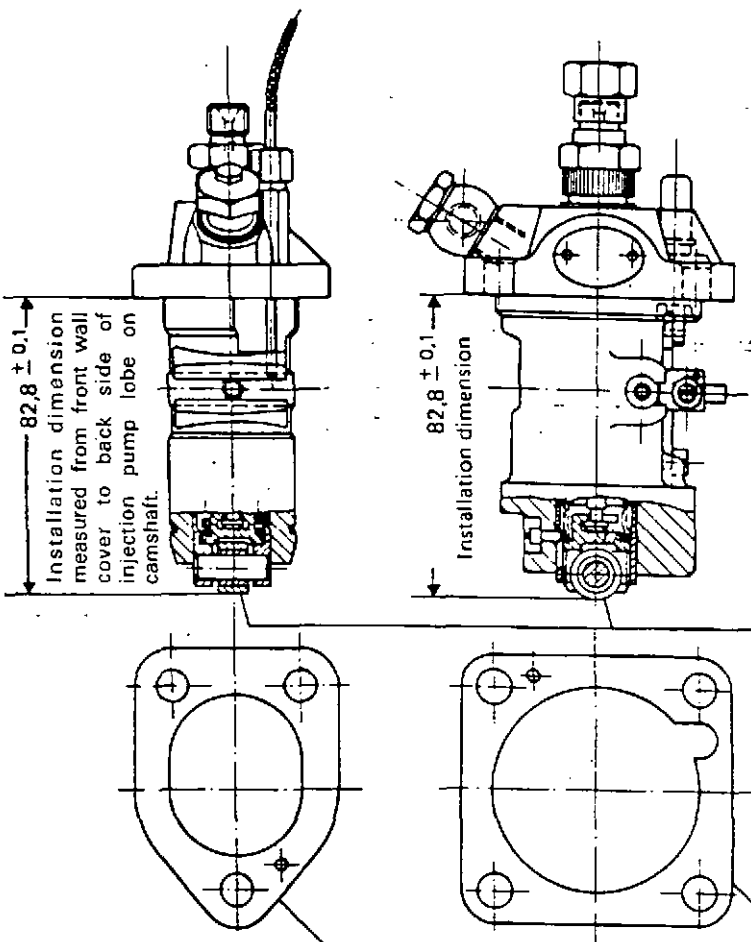
Table for wear parts limit dimensions

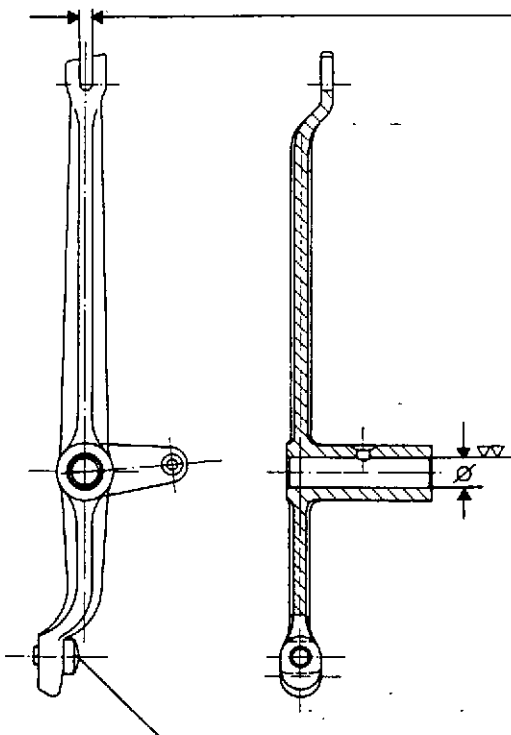
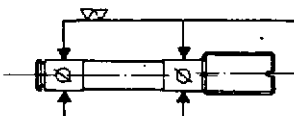
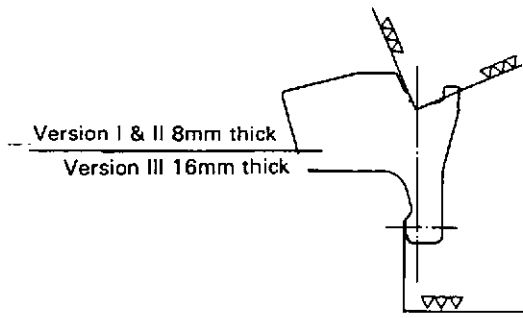

No.	Description	Dimensions		
		New state		wear limit
		max mm	min mm	max mm
41	Decompression shaft 			Renew if worn
42	V-belt pulley for belt tensioner 			Renew ball bearing if showing appreciable play
43	Ring gear on flywheel (1-cylinder) 	284,081	284,000	If teeth are damaged renew ring gear. Heat ring gear uniformly up to 200°-250°C (392°-482°F) for shrink-fit.
	Ring gear on flywheel (2 & 3 cylinder) 	296,081	296,000	
44	Cooling air blower (2-cylinder) 			To rebuild blower, use M5001 tool kit. Replace shaft and bearing assembly if bearings show excessive wear.

Table for wear parts limit dimensions

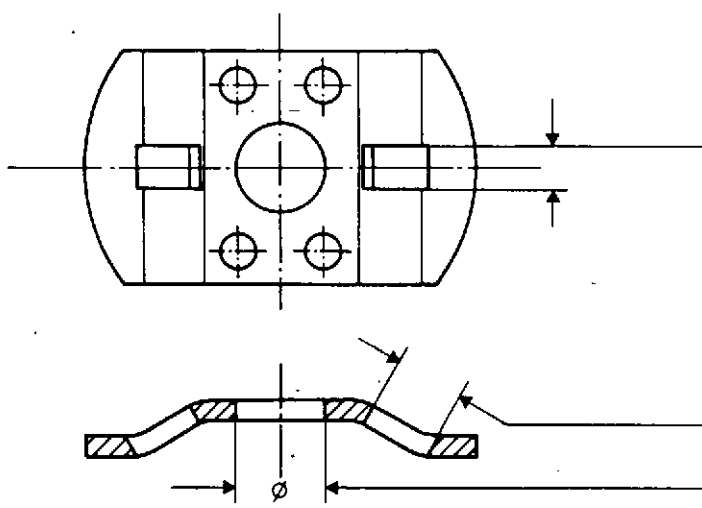
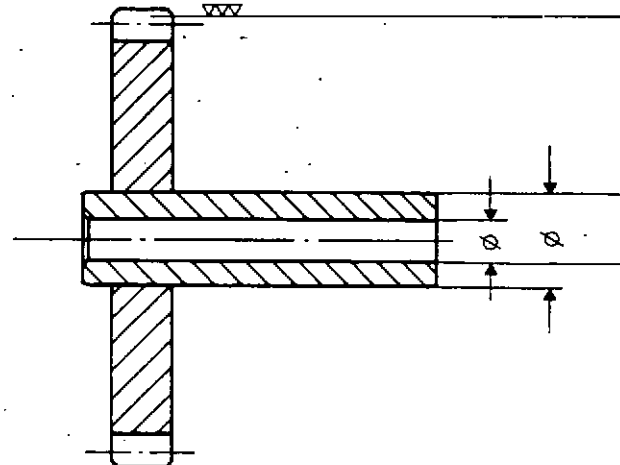
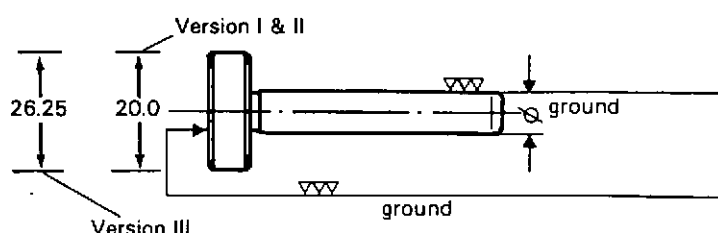
No.	Description	Dimensions		
		New state		wear limit.
		max. mm	min. mm	max. mm
45	Cooling Air Blower (3-cylinder)			

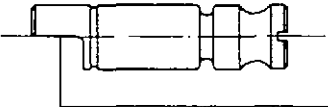
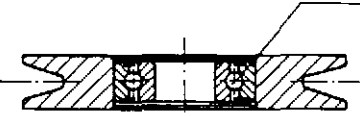

renew ball bearing if showing appreciable play

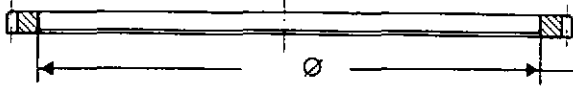
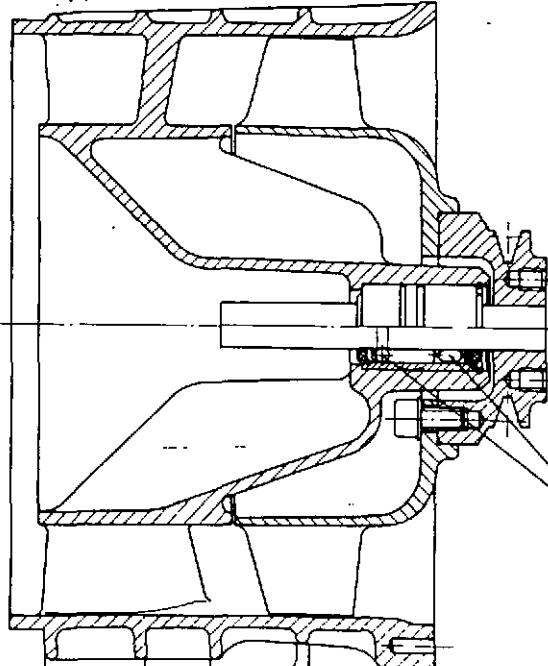
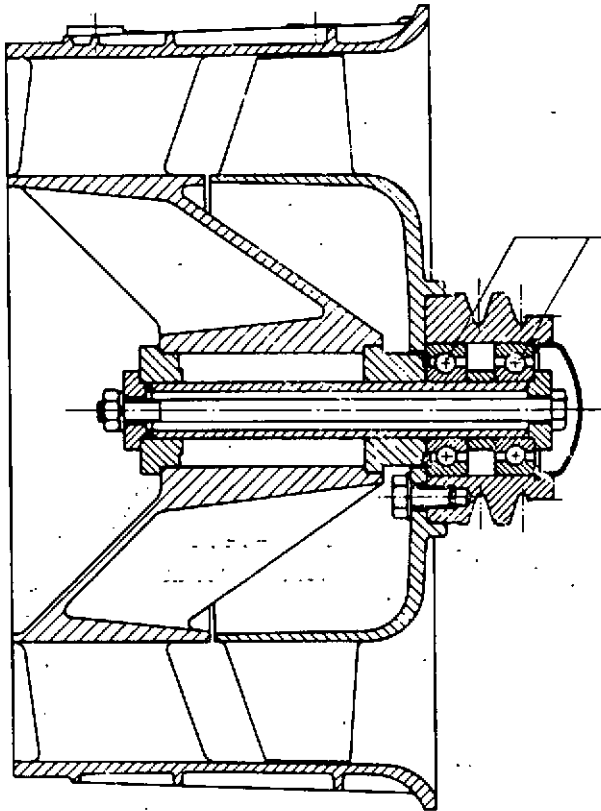
See section in "Service Notes" for sealed bearing information.

5.3 Refurbishing grades

A few engine components which have already reached the no go dimensions can be reconditioned for further use.

Reconditioning must be in accordance with the following tabulated dimensions, the necessary items being listed according to the corresponding reconditioning grade.

5.3.1 Crankshaft D302-1

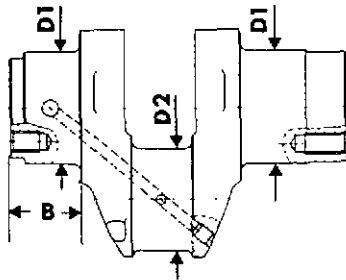

Grade	D1	corresponding main bearing bushing
new	64,97 - 64,951	6.302.0.432.001.4
1	64,72 - 64,701	6.302.8.432.002.4
2	64,47 - 64,451	6.302.8.432.003.4
3	64,22 - 64,201	6.302.8.432.004.4
4	63,97 - 63,951	6.302.8.432.005.4

Grade	B	corresponding bearing ring (crank web end)
new	40,0 - 39,97	6.302.0.433.001.4
1	40,5 - 40,47	6.302.8.433.011.4

Grade	D2	corresponding rod bearing
new	57,97 - 57,951	6.327.0.430.001.7
1	57,72 - 57,701	6.327.8.430.003.7
2	57,47 - 57,451	6.327.8.430.005.7
3	57,22 - 57,201	6.327.8.430.007.7
4	56,97 - 56,951	6.327.8.430.009.7

Crankshaft D302-2 & D302-3

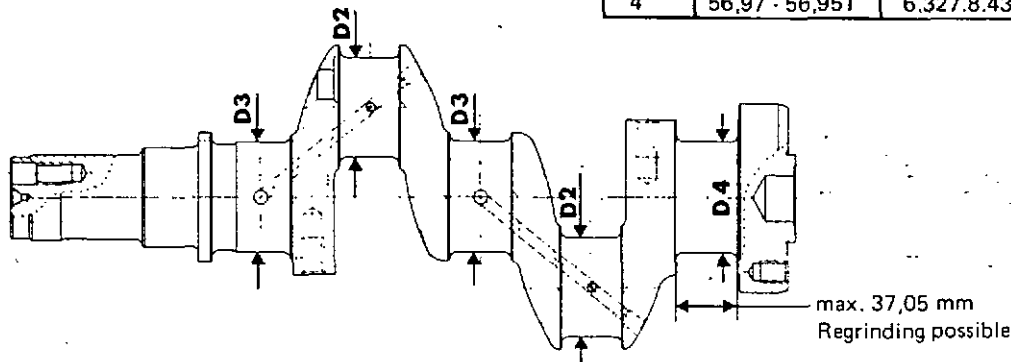

Grade	D3	corresponding main bearing
new	64,97 - 64,951	6.305.0.430.001.7
1	64,72 - 64,701	6.305.8.430.003.7
2	64,47 - 64,451	6.305.8.430.005.7
3	64,22 - 64,201	6.305.8.430.007.7
4	63,97 - 63,951	6.305.8.430.009.7

Grade	D4	corresponding rear main thrust bearing
new	64,97 - 64,951	6.305.0.430.400.7
1	64,72 - 64,701	6.305.8.430.410.7
2	64,47 - 64,451	6.305.8.430.412.7
3	64,22 - 64,201	6.305.8.430.414.7
4	63,97 - 63,951	6.305.8.430.416.7

SUBJECT: Rear Main Bearing Thrust Specifications

There have been some changes made in the rear thrust dimension for the 4 repair stage main bearings.

The new bearings will have "standard" thrust specifications listed in Chart 1, below.

Stock will retain the former (or "optional") thrust width bearings for service situations requiring thrust widths not offered in the standard thrust bearings. These optional thrust width bearings will be available on a limited basis until stock is exhausted.

When ordering repair stage I, II, III and IV rear main bearings, specify desired thrust width.

NOTE: When a service situation arises, where material will need to be removed from the thrust surface of the rear main bearing shell set, a maximum of .5mm (.020") per side (1 mm total) may be removed. This should be carried out by a qualified machinist at time of crankshaft regrind.

**CHART 1
CRANKSHAFT THRUST GRIND SPECIFICATIONS**

PART NUMBER	REAR MAIN BEARING	STD. BEARING THRUST WIDTH	STD. CRANK. THRUST WIDTH	OPTIONAL BRG. THRUST WIDTH	OPTIONAL CRANK. THRUST WIDTH
6.305.0.430.400.7	Standard (new)	35.82-35.88	36.00-36.05		
6.305.8.430.410.7	Repair Stage I	35.92-35.98	36.10-36.15	37.00	max. 37.05
6.305.8.430.412.7	Repair Stage 2	36.07-36.13	36.25-36.30	35.85 37.00	36.00-36.05 max. 37.05
6.305.8.430.414.7	Repair Stage 3	36.07-36.13	36.25-36.30	37.00	max. 37.05
6.305.8.430.416.7	Repair Stage 4	36.32-36.38	36.50-36.55	37.00	max. 37.05

Crankshaft End Thrust Clearance is .08-.23 mm (.003"-.009")

5.3.2 Camshaft D 302-1

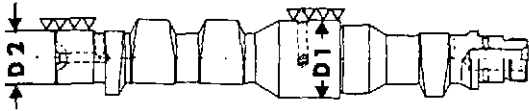

Grade	D1	D2	see 5.3.3 for housing
new	42,96 - 42,94	29,96 - 29,94	
1	42,66 - 42,64	29,66 - 29,64	

Camshaft D302-2 & D302-3

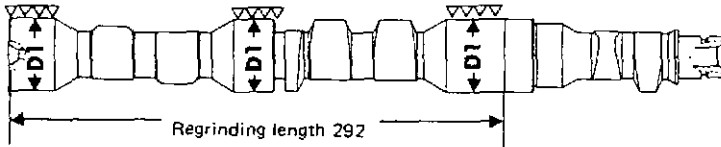

5.3.3 Camshaft bore in crankcase D302-1

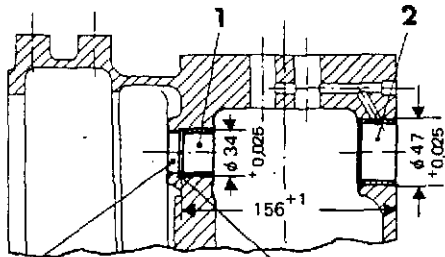

If cover is removed for refinishing operations, place new cover 30 DIN 443-MWM - Nr. 6.0215.21.5.0030. And bore again after applying the bushes.

Caution!
Do not drill here.

Camshaft bore in crankcase D302-2 & D302-3

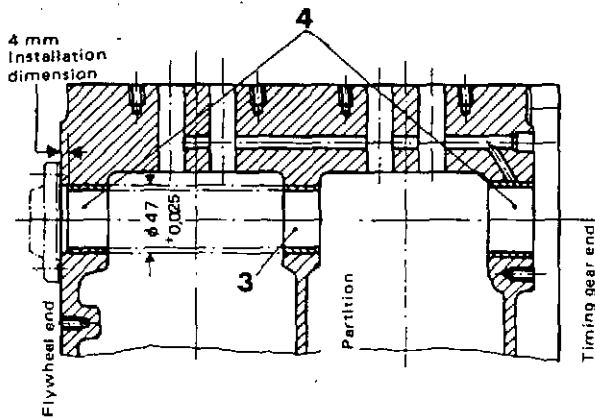

If housing is equipped with a cord seal (cover with groove), use cover 6.305.0.787.011.4 and oval gasket 6.305.0.852.001.4 after applying the bushes.

Repair instructions

1. Remove bearing bush on timing gear end.
2. Camshaft bores on flywheel end are to be drilled out to $34^{+0.025}$ for installation of bearing bushes.
D 302-1
- 2a. Camshaft bores on flywheel end partition are to be drilled out to $47^{+0.025}$ for installation of bearing bushes. D 302-2.
3. Fit new bearing bushes. Make sure when fitting the bearing bushes that they allow oil to pass freely through oil drillings from crankcase.
4. Finely bore according to the camshaft used (genuine part or under-size stage) to $43^{+0.025}$ or $42.7^{+0.025}$ or $30^{+0.021}$ or $29.7^{+0.021}$.

Admissible parallel misalignment between camshaft bore and crankshaft axis relative to crankcase length : 0.05 mm

5. Carefully clean interior after precision-drilling so that no remains are left in oil drillings.

Position	Quantity			Bushing Part No.
1	1			6.302.8.432.006.3
2	1			6.302.8.432.007.3
2*	1			6.302.0.432.006.4
3		1	2	6.305.8.432.003.2
4		2	2	6.305.8.432.002.2
4*		1	1	6.308.0.432.001.4
	1	2	3	
	cyl.	cyl.	cyl.	

*New (front only)

5.3.4 Finned cylinder

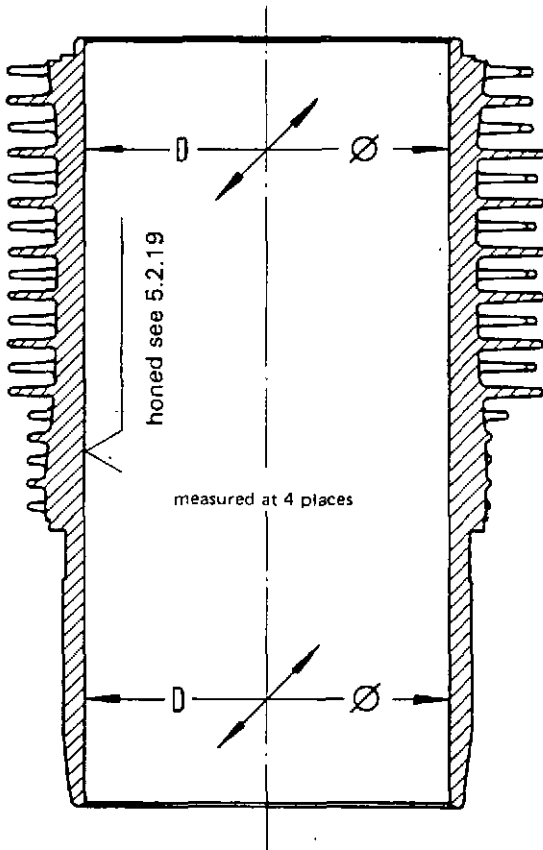

Stage	D	Standard Output Pistons	2 & 3 cyl. High Output Pistons*
new	95-95,022	6.308.0.160.004.7	6.302.0.160.003.7
1	95,5-95,522	6.308.8.160.041.7	6.302.8.160.031.7
2	96-96,022	6.308.8.160.042.7	6.302.8.160.032.7

new		corresponding pistons rings 6.325.0.019.001.7 ring set
I	95/86,8x3	6.0503.28.1.0951
II	95/86,8x3	6.0503.19.0.0953
III	95/86,8x3	6.0503.65.0.0951
IV	95/86,8x5	6.0503.80.2.0951

Stage 1		6.302.0.019.014.7 ring set
I	95,5/87,3x3	6.0503.28.1.0956
II	95,5/87,3x3	6.0503.19.0.0957
III	95,5/87,3x3	6.0503.65.0.0956
IV	95,5/87,3x5	6.0503.80.2.0952

Stage 2		
I	96/87,8x3	6.0503.28.1.0961
II	96/87,8x3	6.0503.19.0.0962
III	96/87,8x3	6.0503.65.0.0961
IV	96/87,8x5	6.0503.80.2.0961

*See note on piston, item #18a, page 37, when converting engine from standard output to high output.

5.3.5 Cylinder head, valve guides and valve seating inserts

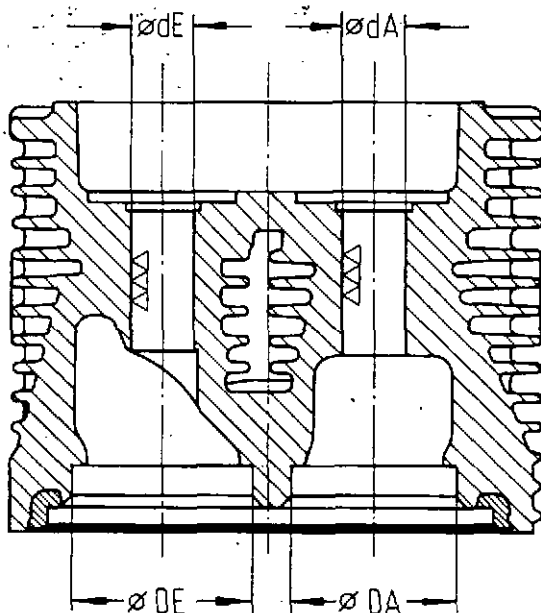

Stage	dE	dA	corresponding valve guides
new	14,995-15,005	14,985-14,995	6.305.0.332.003.4
1	15,095-15,105	15,085-15,095	6.305.8.332.031.4
2	15,195-15,205	15,185-15,195	6.305.8.332.032.4

Stage	DE	corresponding valve seating insert Inlet
new	38,96-38,976	6.327.0.345.003.3
2	39,16-39,176	6.327.8.345.032.3

Stage	DA	corresponding valve seating insert Exhaust
new	35,96-35,976	6.327.0.345.004.3
2	36,16-36,176	6.327.8.345.042.3

Sequence:

1. Heat cylinder head up to approx. 200°C (392°F).
2. Insert valve seat rings and valve guides.
3. Let cylinder head cool down to ambient temperature.
4. Finish valve seats: Inlet 45°
Exhaust 45°.

Engine disassembly and assembly procedures

6.1 General

- Replace worn parts, referring to spare parts list for order numbers (spare part numbers).
- Take care to ensure maximum cleanliness when assembling.
- Lubricate all sliding surfaces on bearings, shafts, gears, levers, as well as pistons and finned cylinders (inside) with clean engine oil.
- Assembly is carried out in the reverse sequence to that of dismantling.
- Following procedures are described in more detail in the following.

	Page
6.2 Special service tools	52
6.3 General disassembly and assembly procedures	53-65
6.4 Standard torque values	67
6.5 Special torque specifications	68-69
6.6 Bearing clearances	70
6.7 Gear train timing	70
6.8 Gear backlash	71
6.9 Piston clearance (dial indicator)	71
6.10 Compression clearance (lead wire check)	71
6.11 Fuel injection pump timing	72-75
6.12 Governor adjustments	76-83
6.13 Crankshaft seals	84-85
6.14 Service notes	86-89

6.2 Special Service Tools

The "M" series tools, described in this shop manual and others that were under development at time of printing, are available from Owatonna Tool Company (OTC). For a catalog, availability, cost, or other information, contact the following:

MWM-Murphy Diesel Company
Service Department
5317 West Burnham
Milwaukee, WI 53219
(414) 645-2255
TELEX 6878013
MWMMD UW

or

Owatonna Tool Company (OTC)
Service Tools Division
2013 4th Street NW
Owatonna, MN 55060
(507) 451-0514
TELEX: 29-0876

6.3 General disassembly and assembly procedures

- Clean engine exterior thoroughly prior to dismantling.
- Select well lit location (workbench) providing for unrestricted movement and free of dirt and moisture.
- Place tools and devices in readiness.

- The jobs listed in this table are to be carried out step-by-step in the sequence shown and as illustrated.
- Please read the corresponding description of the jobs involved prior to starting work, so that you are fully familiar with the scope involved.

6.3.1 Draining lube oil

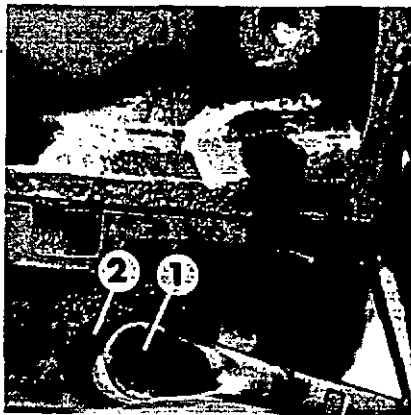

Sequence:

1. Prepare a collecting tank for the draining oil (oil quantity; see technical data section).
2. Slacken and remove oil drain plug 1; note copper sealing washer 2.
3. Wait until all oil has run out.

Draining fuel tank

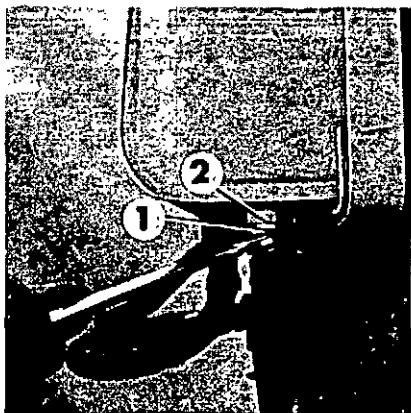

1. Prepare a collecting tank for the draining fuel.
2. Slacken and remove plug 1. Note gasket 2.

6.3.2 Removing fuel tank

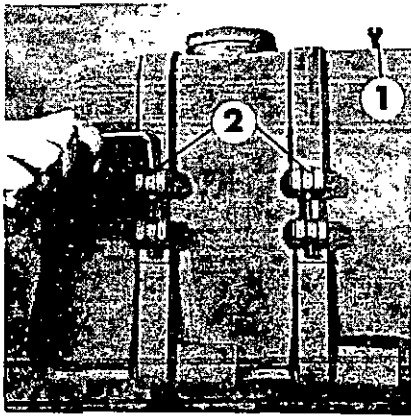

Sequence:

1. Unscrew fuel leak-off line 1 on fuel tank.
2. Unscrew flexible pipe on fuel delivery pump leading to fuel tank.
3. Unscrew hexagonal socket screws 2.

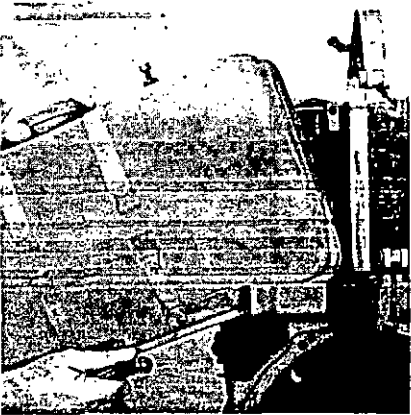

4. Remove fuel tank.

6.3.3 Removing cooling air housing D302-1

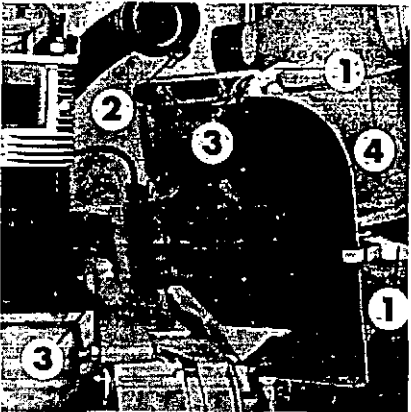

1. Open clamps 1.
2. Loosen hose clamp 2.
3. Unscrew fuel filter.
4. Unscrew hex screws 3.
5. Remove cooling air housing 4 with oil bath air filter.

Removing cooling air housing D 302-2 and 3



1. Open clamps 1.
2. Remove cooling air housing.

6.3.4 Removing cover plate

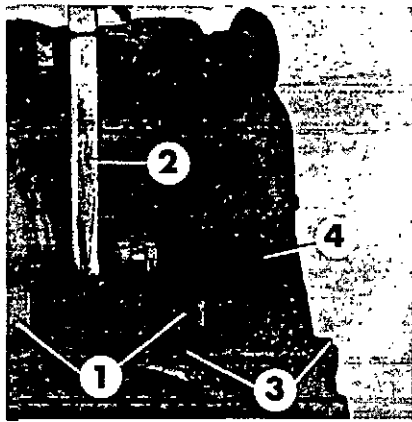

Sequence:

1. Remove brackets 1 and clamp 2.
2. Unscrew hex bolts 3.
3. Remove cover plate 4.

6.3.5 Removing exhaust and intake pipe

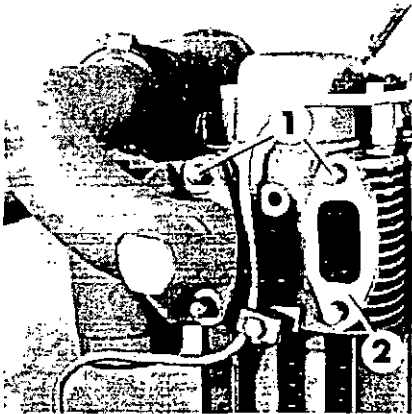

1. Remove nuts 1 from exhaust and intake pipe 1.
2. Note gasket 2 when removing the exhaust and intake pipe.

6.3.6 Removing cylinder head cover

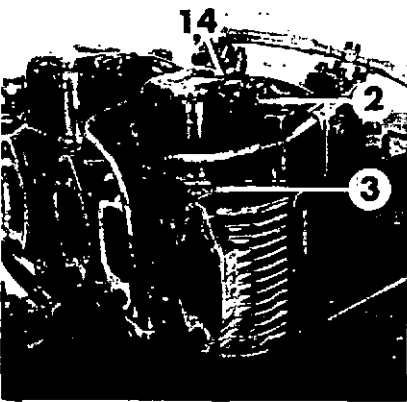

1. Remove hex bolt 1.
2. Remove cylinder head cover 2.
3. Note shaped gasket 3 and copper sealing washer 4.

6.3.7 Removing rocker arm bracket

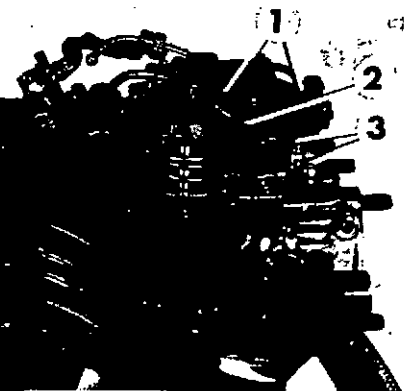

1. Remove hex bolts 1.
2. Remove rocker arm bracket 2.
3. Take out push rods 3.

6.3.8 Removing fuel injection nozzle

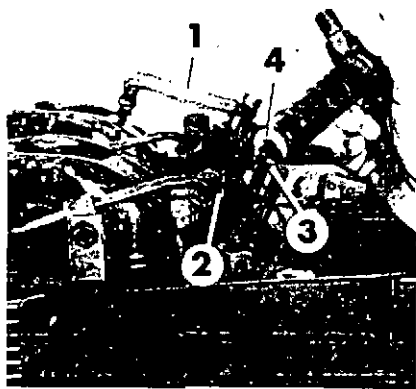

Sequence:

1. Unscrew leak-off line 1.
2. Unscrew cap nut 2 from fuel delivery line.
3. Unscrew nuts 3 on mounting bracket.
4. Removed domed washers and mounting bracket.
5. Remove fuel injection nozzle.
6. Note tip gasket 4.

Assembly note:

Tip gaskets should never be reused. Metal side of tip gasket goes towards the head upon assembly. Observe special torque requirements.

6.3.9 Dismantling fuel injection nozzle

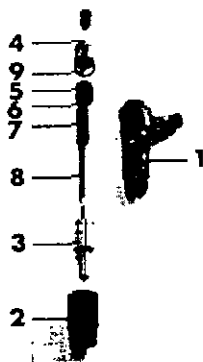

1. Clamp nozzle body 1.
2. Unscrew cap nut 2.
3. Take multi-hole nozzle 3 out. (Exchange if necessary.)
4. Unscrew cap nut 4.
5. Remove spring plate 5.
6. Remove shim 6, pressure spring 7, and thrust bolt 8.
7. Note sealing ring 9 when reassembling.

6.3.10 Removing fuel delivery line

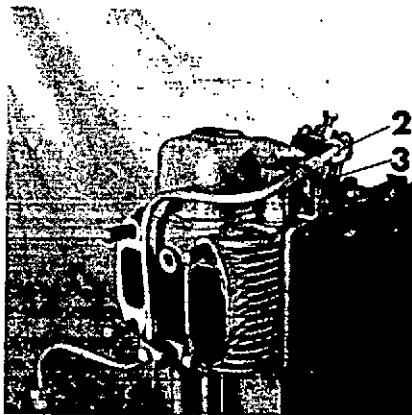

1. Unscrew cap nut 1 on injection pump.
2. Unscrew cap nut 2 on injection nozzle.
3. Unscrew pipe clamp halves 3 on cylinder head.

6.3.11 Removing cylinder head

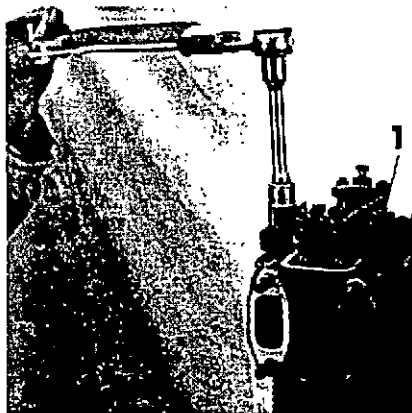

1. Unscrew hex. nuts 1 (4 per cylinder head) on the tie bolts with a socket.

Assembly note:

Observe special torque requirements, section 6.5.

6.3.12 Taking down cylinder head

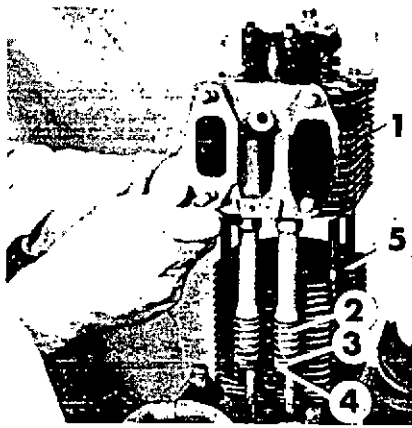

Sequence:

1. Lift cylinder head 1.
2. Note pressure spring 2, thrust ring 3, O-ring 4 and copper head gasket 5.

6.3.13 Removing valves

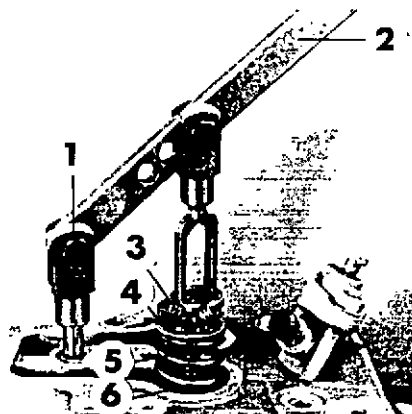

1. Fix valve spring compressor 1.
2. Press lever 2.
3. Remove valve keepers 3 using a screwdriver with heavily greased end.
4. Take down spring plate 4, pressure spring 5 and shim 6.

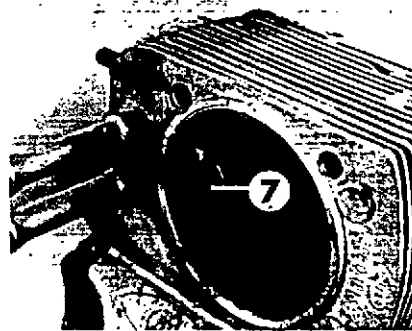

5. Take valves 7 out from bottom.

6.3.14 Removing finned cylinder

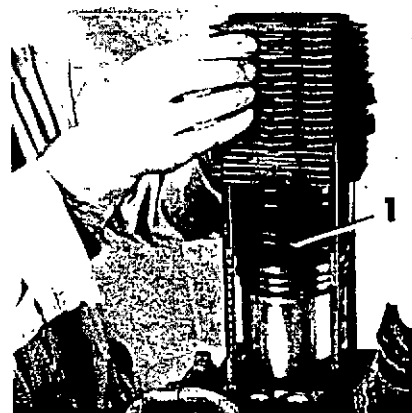

1. Take finned cylinder out from top.
2. Note shim(s) 1.

Assembly note:

Shift butt joint faces of the piston rings by 180° each (e.g., opposing in sequence).
Exchange rubber O-ring in crankcase.

6.3.15 Removing piston

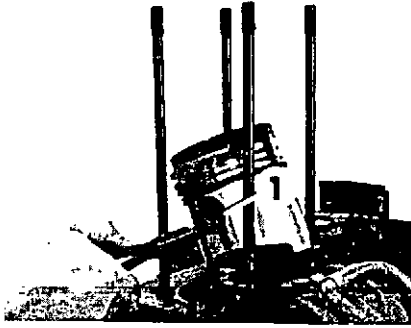

Sequence:

1. Remove clip 1 with snap ring pliers.
2. Take piston pin out.

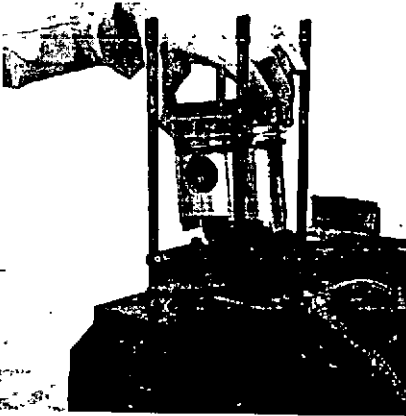

3. Remove piston.

6.3.16 Removing oil pan

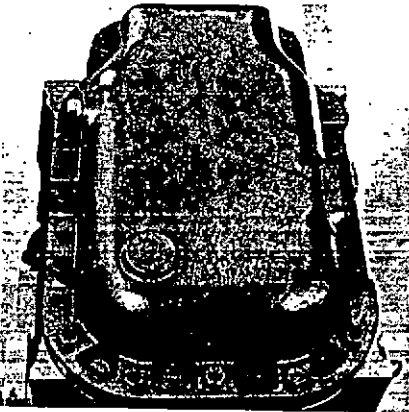

1. Remove all bolts from oil pan.
2. Loosen and remove oil pan from gasket using a screwdriver or lever.

Assembly note:

Make sure that gasket surfaces are perfectly clean. Coat joint between crankcase and end cover with RTV sealant (for D 302-2 & D 302-3 only). Observe special torque requirements, section 6.5.

6.3.17 Removing oil intake line

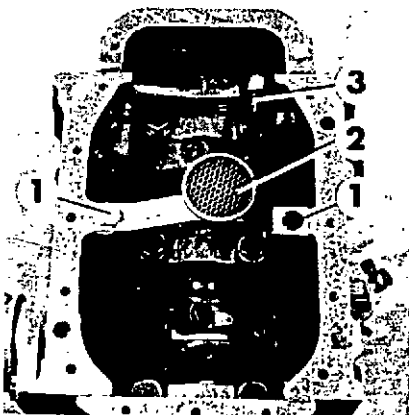

1. Remove hex nuts 1.
2. Remove oil intake pipe 2.
3. Note O-ring 3.

6.3.18 Removing v-belt pulley D302-1

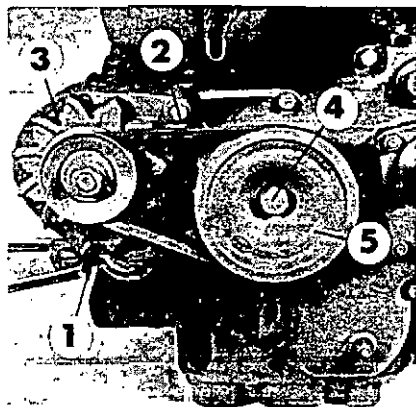

Removing v-belt pulley D302

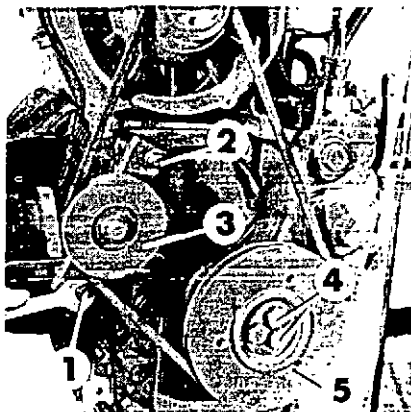

6.3.19 Removing injection pump D302-1

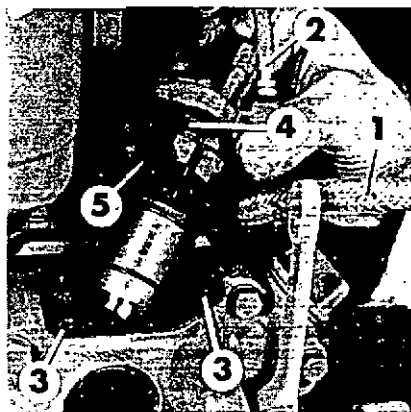

Removing injection pump D302-2

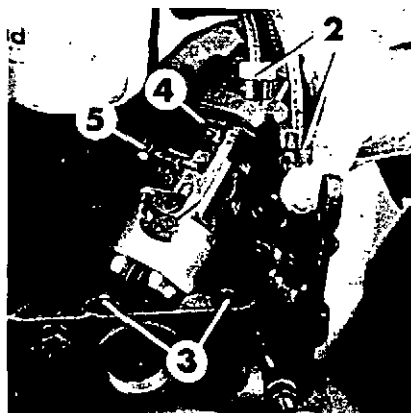

Sequence:

1. Slacken hex nuts 1 and 2.
2. Push alternator 3 inward. Remove v-belt.
3. Unscrew hex nut 4 using a socket. Note lockwasher.
4. Take v-belt pulley 5 out.

Assembly note:

Observe special torque requirement, section 6.5.

1. Slacken hex nuts 1 and 2.
2. Press adjusting pulley 3 or alternator inward. Remove v-belt.
3. Unscrew hex nuts 4 using a box spanner.
4. Remove v-belt pulley 5.

Assembly note:

Observe special torque requirement, section 6.5.

1. Close fuel feed line.
2. Unscrew fuel feed line 1 on injection pump.
3. Unscrew fuel line 2.
4. Unscrew bolts 3 on injection pump flange.
5. Remove injection pump.
6. Note shims 4 under injection pump flange.

Assembly note:

Crank engine so that fuel cam lobes on camshaft are turned down. Guide piece 5 on injection pump rack must slide in the injection regulating lever fork without binding. Check for smooth running of the rack, the injection pump flange being tightened. Vent fuel lines. Check fuel injection pump timing and governor adjustments.

6.3.20 Removing cooling air blower

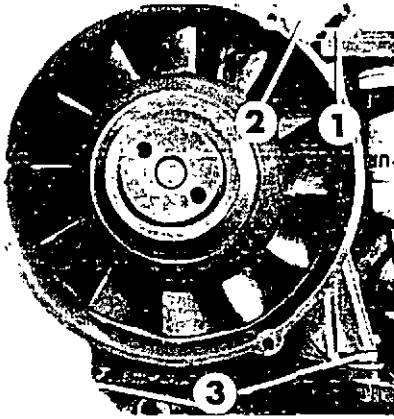

Sequence:

1. Unscrew hex nuts 1 and remove fuel filter.
2. Loosen clamp ring 2.
3. Unscrew hex nuts 3 (4 in all).
4. Remove cooling air blower.

Assembly note:

The v-belt pulley must precisely line up with the v-belt pulley on the crankshaft.

6.3.21 Removing front wall cover

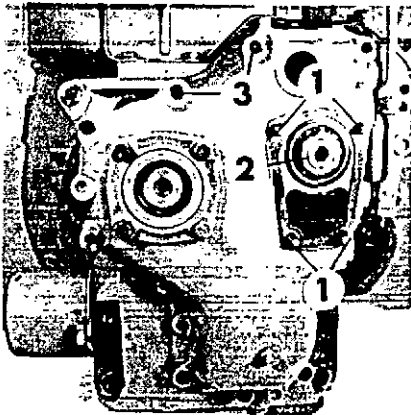

1. Unscrew hex bolts 1 and take down end cover.
2. Unscrew hex bolt 2 (left-hand thread).
3. Unscrew all hex bolts 3.
4. Loosen and remove front wall cover by gentle side tapping.

Assembly note:

Observe tightening torque, section 6.4.

6.3.22 Front wall cover inside (Versions I and II shown)

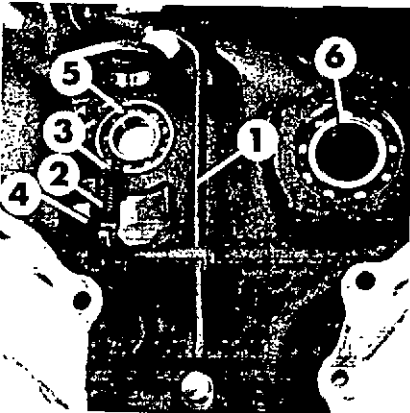

1. Governor regulating lever.
2. Governor control spring.
3. Speed adjustment lever inside.
4. Eccentric for max. speed adjustment.
5. Groove ball bearing (camshaft).
6. Groove ball bearing (counterweight D 302-1 only).

6.3.23 Front wall cover removed (D302-1)

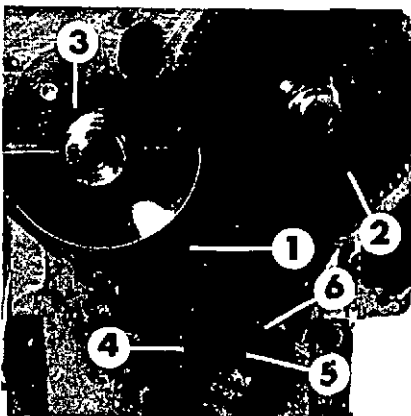

1. Crankshaft gear
2. Camshaft gear
3. Counterweight gear
4. Oil pump gear
5. Governor shaft
6. Flyweights (2)

6.3.24 Removing balance weight

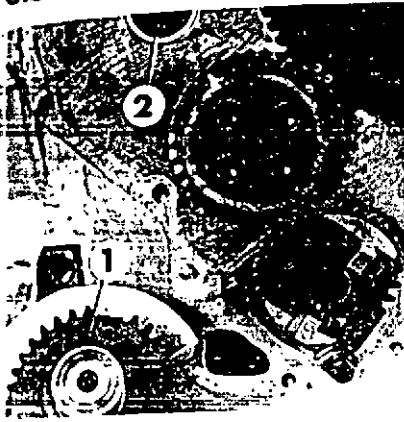

Sequence:

1. Remove counterweight 1 from bearing bush 2.

6.3.25 Removing governor

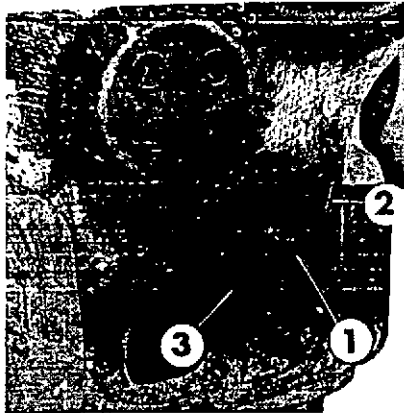

1. Draw out governor shaft 1.
2. Remove governor weights from support 3.

6.3.26 Removing oil pump D 302-1

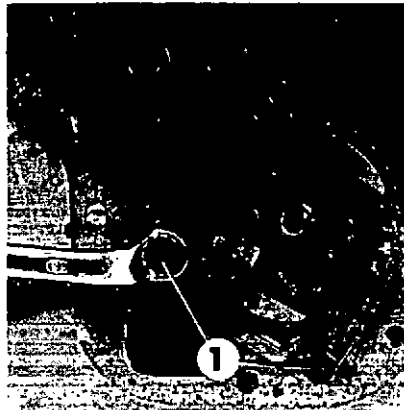

1. Unscrew hex nuts 1.
2. Remove oil pump.

Removing oil pump D 302-2 & 3

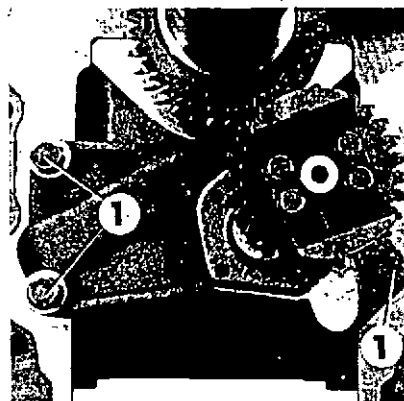

1. Unscrew hex nuts 1.
2. Take down oil pump

Assembly instruction:
Backlash: note section 6.8.

6.3.27 Removing crankshaft gear

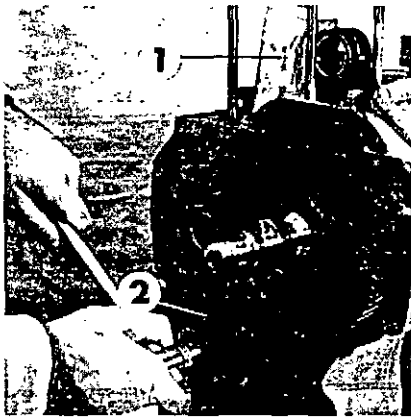

Sequence:

1. Hold crankshaft 1.
2. Unscrew hex bolts 2 using a hex socket.
3. Take down spur gear.

Caution:

Do not damage crank pin surface.

2. Unscrew hex bolts 2 using a hex socket.
3. Take down spur gear.

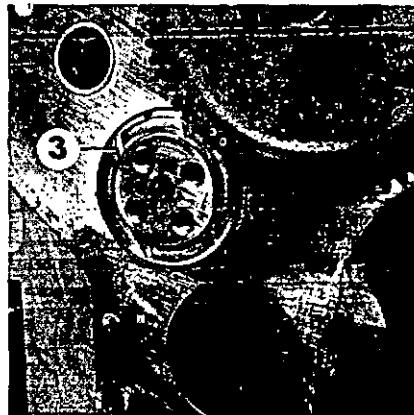

Assembly instruction:

Oil pockets on bearing ring 3 must face spur gear.
Observe special torque requirements, section 6.5.

6.3.28 Removing feed pump

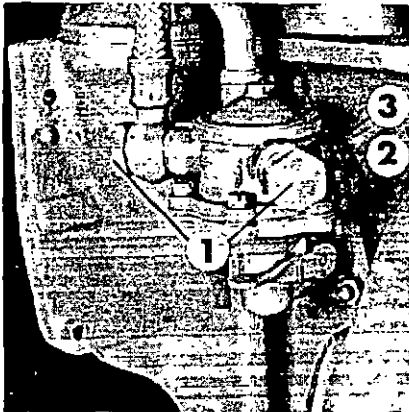

1. Close fuel feed line.
2. Unscrew hollow screws 1 and remove fuel lines; note packing rings.
3. Unscrew hex bolts 2.
4. Take down feed pump. Note shaped gasket 3.

Assembly instruction:

Vent fuel lines.

6.3.29 Removing camshaft



1. Place engine on head.
2. Press mushroom-head tappets downward (in direction of cylinder).
3. Turn camshaft during removal.
4. Take mushroom-head tappets out of case bore.

Note: M1013 Magnetic Tappet Holder Kit can be used to hold tappets away from camshaft when removing camshaft with engine in upright position.

6.3.30 Removing connecting rod D 302-1

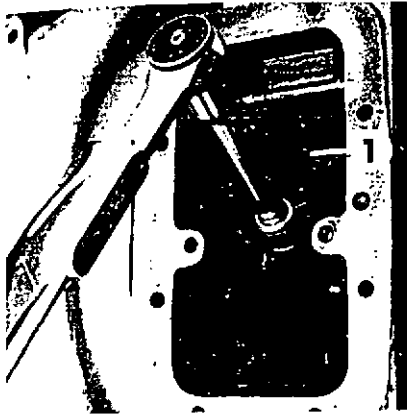

Removing connecting rod D302-2 & 3

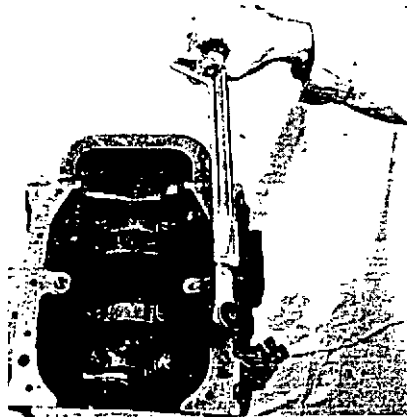

6.3.31 Removing counterweights

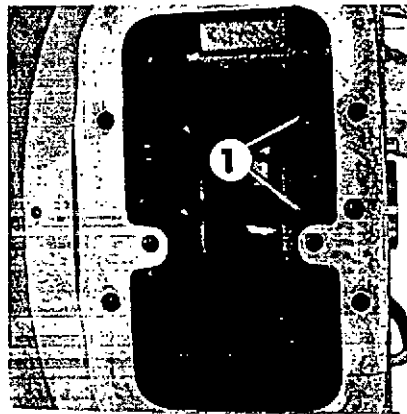

6.3.32 Removing flywheel

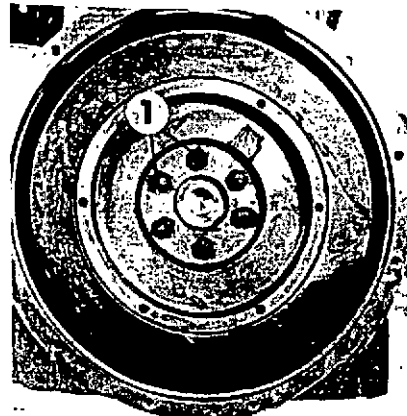

Sequence:

1. Unscrew connecting rod bolts 1 using a socket.
2. Remove bolts with connecting rod bearing cap.
3. Remove connecting rod from top.
4. Note connecting rod bearing shells.

Assembly instruction:

Insert bearing shells noting the locating pin. It is recommended to install lower shell, ensuring indexing of the notch with the locating pin in the rod prior to installing the connecting rod bearing cap. Observe special torque requirements, section 6.5.

1. Mark position of counterweights.
2. Unscrew hex socket screws 1 using a hex socket.
3. Take down counterweights.

Assembly instruction:

Observe special torque requirements, section 6.5.

1. Hold crankshaft

Caution:

Do not damage crank pin surface.

2. Unscrew fastening bolts 1 using a box spanner.
3. Lift flywheel from crankshaft.

Assembly instruction:

Note: "One-way" bolt pattern on D302-2 and D302-3 flywheels. Observe special torque requirements, section 6.5.

6.3.33 Removing flywheel housing D 302-2

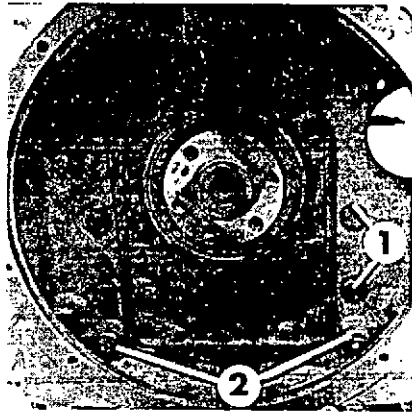

Sequence:

1. Unscrew all fastening bolts 1 and nuts 2 on flywheel housing.
2. Loosen and remove housing by gentle tapping.

Assembly instruction:

Observe special torque requirements, section 6.5.

6.3.34 Removing front wall cover D 302-2

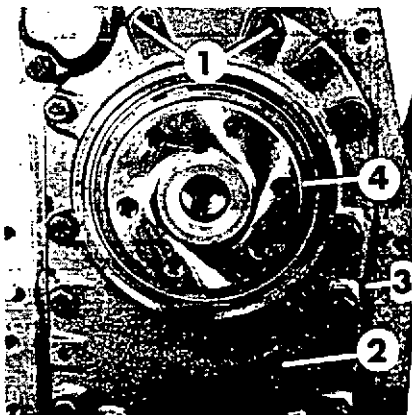

1. Unscrew all fastening bolts 1 on front wall cover.
2. Take down front wall cover 2.
3. Note shaped gasket 3.

Assembly instruction:

Slightly coat sealing lip on radial seal 4 with grease.

6.3.35 Removing crankshaft D302-1

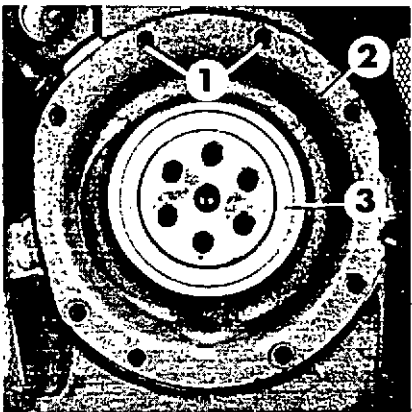

1. Unscrew and take all hex bolts out of tap holes 1.
2. Loosen bearing cover 2 by gently tapping on crankshaft (counter-side) using a rubber mallet.
3. Remove bearing cover.

Assembly instruction:

Replace radial seal 3 and O-ring on bearing cover and slightly coat with grease.

6.3.36 Removing bearing cover D302-1

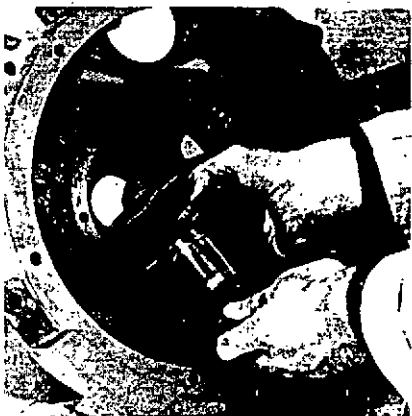

Remove crankshaft through bearing cover opening.

6.3.37 Crankshaft removed D 302-1

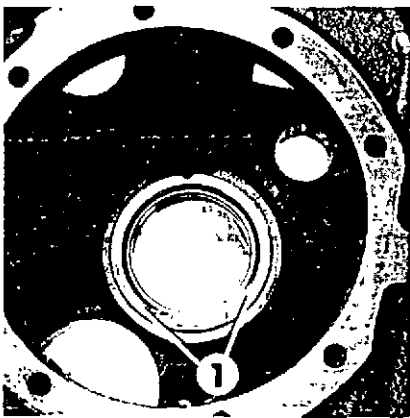

Sequence:

Assembly note:

Oil pockets on bearing ring 1 must face crank web end.
Note axial clearance, section 6.6

6.3.38 Removing main bearing D302-2 & 3

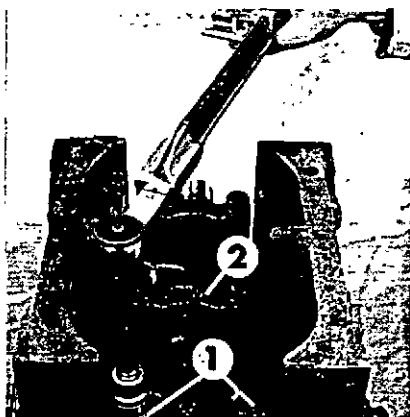

1. Remove main bearing bolts 1.
2. Lift off bearing cover 2. Bearing covers are numbered from rear.
3. Note bearing shells.

Assembly Note:

Do not confuse bearing shells and bearing caps. Observe special torque requirements, section 6.5.

6.3.39 Removing crankshaft D302-2



Lift crankshaft from crankcase.

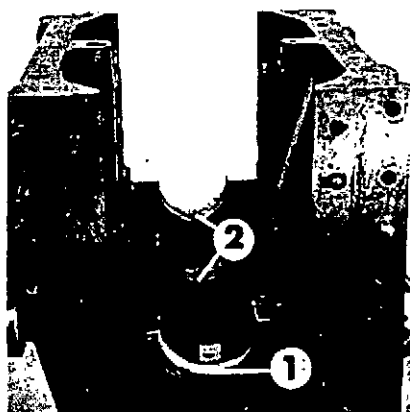

Assembly instruction:

Insert thrust bearing 1 and main bearing 2 noting locating pin in bearing cover. Observe axial clearance, section 6.6

6.4 Standard Torque Values

GRADE	5.6		6.9		8.8		10.9		12.9	
	Nm	LB.-FT.	Nm	LB.-FT.	Nm	LB.-FT.	Nm	LB.-FT.	Nm	LB.-FT.
M4	1.3	1	2.4	1.7	2.9	2	4	3	5	3.6
M5	2.5	1.8	4.8	3.5	5.7	4.2	8	5.9	9.5	7
M6	4	3	8	6	10	7	14	10	16	11.8
M7	7	5.2	13	9.6	16	11.8	23	17	27	20
M8	10	7	20	15	25	18	35	26	40	29
M10	20	15	40	29	45	33	65	48	80	59
M12	34	25	70	52	80	59	115	85	140	103
M14	55	41	110	81	130	96	185	136	220	162
M16	84	62	170	125	200	147	272	201	326	240
M18	116	83	235	170	265	191	373	267	448	324
M20	166	120	330	238	380	274	535	387	640	462
M22	235	162	440	318	510	368	725	524	870	629
M24	287	207	570	412	650	470	920	665	1100	796
M27	430	311	840	607	980	708	1380	998	1670	1208
M30	580	419	1130	817	1340	969	1880	1360	2260	1635
M33	800	578	1540	1114	1830	1324	2580	1866	3080	2228

For special torque specifications, see page 68.

6.5 Special Torque Specifications

The following bolted joints can exhibit the necessary strength capability only when tightened to correct torque. It is therefore mandatory that they be tightened in accordance with the following torque requirements.

Note: For standard torque values see page 67.

Pos.	Bolted connections	Thread/material	Tightening torque Nm (lb-ft)	
			min	max.
1	Cylinder head nuts. (See below)	M12m-10	50 (37)	55 (40)
2	Counterweight bolts on crankshaft	M14 - 10.9	140 (102)	150 (108)
3	Main bearing cap bolts	M14 - 10.9	130 (94)	140 (101)
4	Flywheel fastening bolts	M12x1.5 - 10.9	120 (87)	125 (90)
4a	Flywheel fastening bolts *	M12x1.5 - 12.9	120 (87)	125 (90)
5	Crankshaft to v-belt pulley bolts	M12x1.5 - 10.9	120 (87)	125 (90)
5a	Crankshaft to spur gear bolts *	M12 - 10.9	30 (22)	40 (28)
6	Flywheel housing bolts	M10 - 10.9	60 (44)	65 (47)
7	Nut or crank jaw nut on camshaft	M24x2 left thread	200 (145)	210 (151)
8	Connecting rod bolts	M12x1.5 - 10.9	75 (55)	80 (57)
		M12x1.5 - 12.9	95 (69)	100 (72)
9	Counterweight bolt *	M14-8.8	50 (37)	60 (43)
10	Rear bearing cover bolts *	M8 - 8.8	20 (15)	25 (18)
11	Oil pump fastening bolts	M8 - 8.8	20 (15)	25 (18)
12	Rocker arm bracket bolts	M10 - 8.8	3.5 (26)	40 (28)
13	Oil pan bolts	M8 - 8.8	20 (15)	25 (18)
14	Crankcase tie bolts	M12	30 (22)	40 (28)
15	Fuel delivery line nuts (counterholding injection valve pressure connection using an open-ended spanner).	M12 x 1.5	20 (15)	25 (18)
		M14x1.5	20 (15)	25 (18)
16	Injection nozzle hold-down nuts	M8	10 (8)	15 (11)

* for D 302-1 only

CYLINDER HEAD INSTALLATION PROCEDURES

1. Check torque on cylinder head tie rod studs 30-40 Nm (23-29 lb.-ft.).
2. Make sure head gasket contact surfaces are clean on the cylinder head and finned cylinder.
3. Install a new compression gasket.
4. Install cylinder head and washers (4 per head).
5. Lubricate the bottom of the hold-down nuts, nut threads and corresponding tie rod threads with Molykote type "G-n" paste or its equivalent.
6. Install the nuts and tighten equally by hand.
7. Using an accurate straight edge, align all of the machined surfaces of the intake and exhaust ports on the cylinder heads (multi-cylinder engines).
8. Using a criss-cross pattern, tighten the cylinder head hold-down nuts equally in **small** increments to 45-50 Nm (34-36 lb.-ft.).
9. Adjust valve clearance .2 mm (.008").
10. After a test run, approximately 1/2 hour, loosen all cylinder head nuts 1/4 turn and retighten the nuts equally, in **small** increments, to 50-55 Nm (37-40 lb.-ft.).
11. Recheck valve clearance.

6.5.1 Locations of screws and bolts

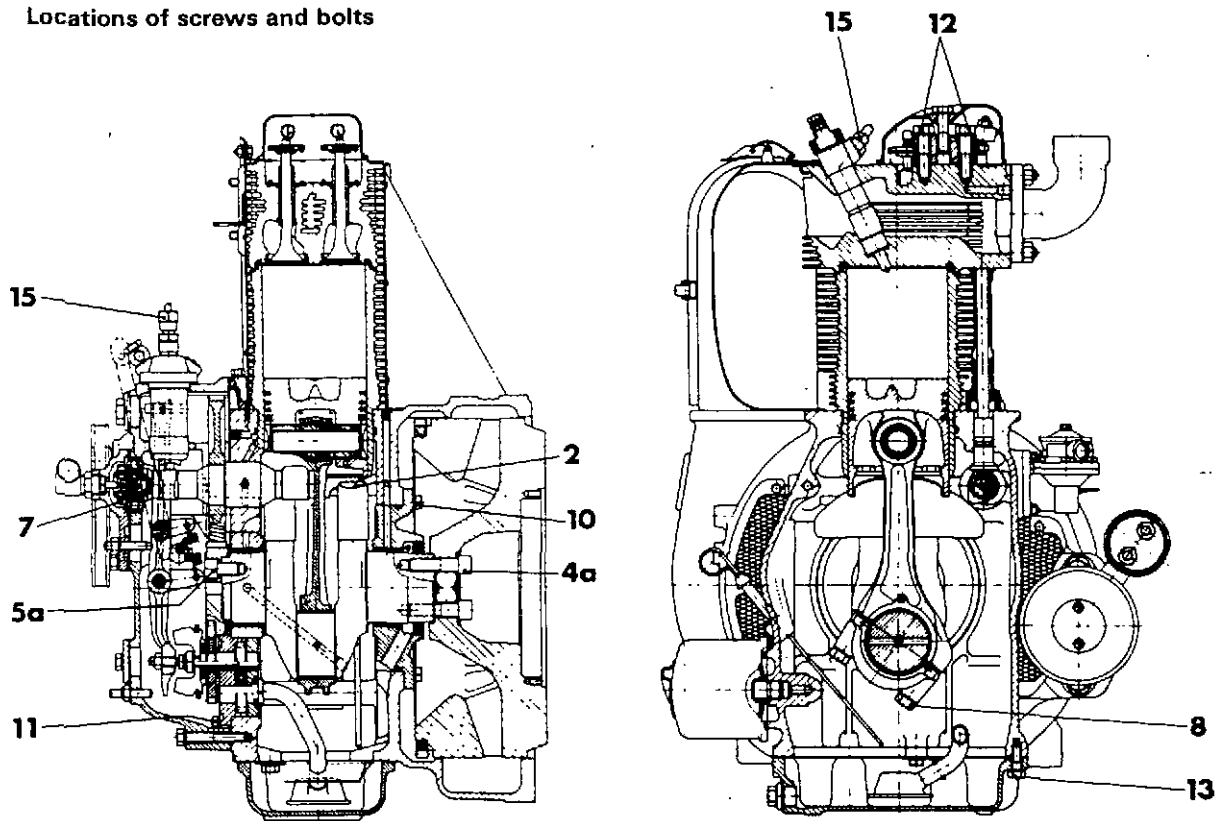

D 302-1

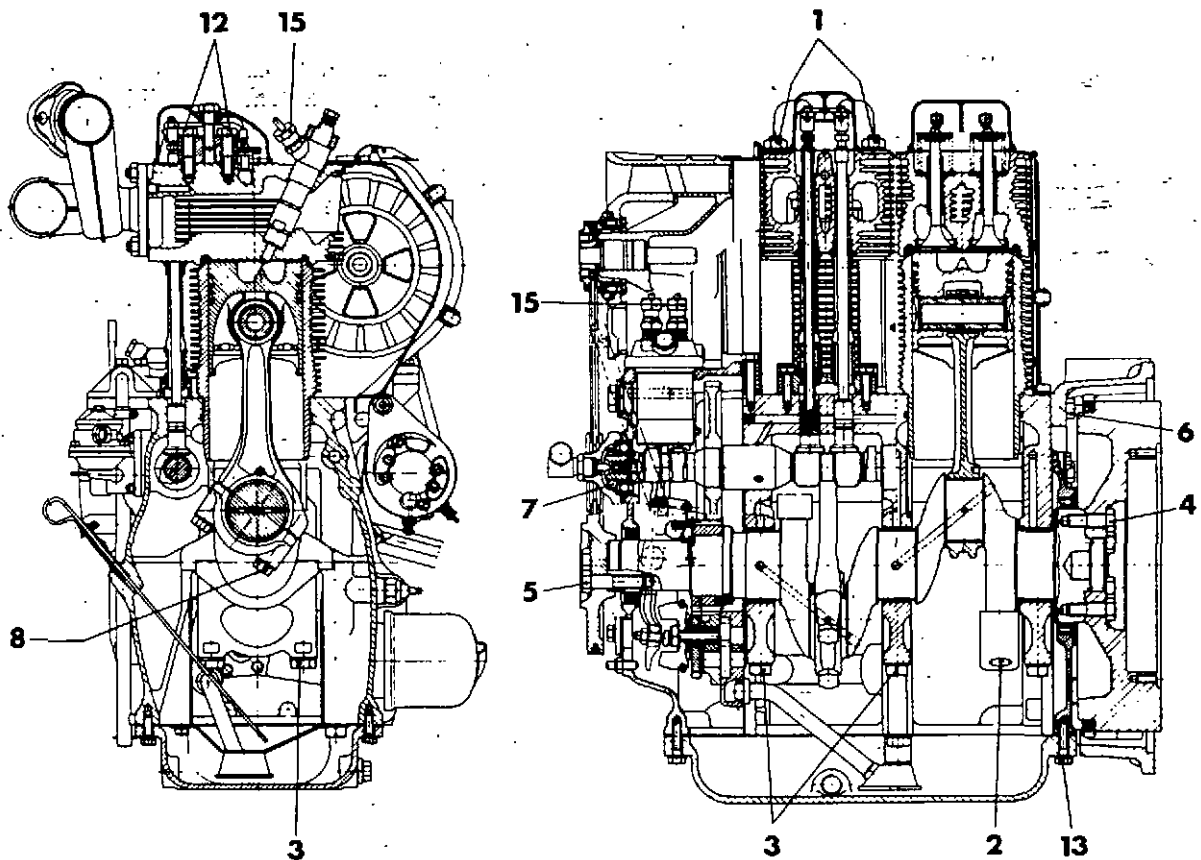

D 302-2 and D 302-3

6.6 Checking bearing clearances using dial indicator or feeler gauges

Bearing/Bushing	RADIAL mm (inches)	AXIAL mm (inches)
	minimum — maximum	minimum — maximum
Main Bearing (1 cylinder)	.07 (.0027) - .12 (.0047)	
Main Bearing (2 & 3 cylinder)	.08 (.0031) - .11 (.0043)	
Thrust Bearing Rings (1 cylinder)		.10 (.0039) - .22 (.0087)
Rear Main Thrust Bearing (2 & 3 cylinder)	.09 (.0035) - .12 (.0047)	.08 (.003) - .23 (.009)
Connecting Rod Bearing	.07 (.0027) - .10 (.0039)	.30 (.0118) - .50 (.0197)
Piston Pin Bushing	.03 (.0012) - .07 (.0027)	
Camshaft Bushing	.04 (.0016) - .08 (.0031)	
Balance Weight Bushing (1 cylinder)	.04 (.0016) - .07 (.0027)	

6.7 Setting gear train timing

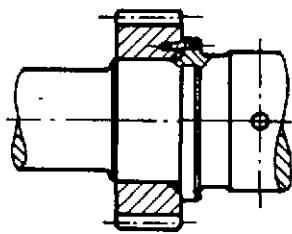

Fig. 1

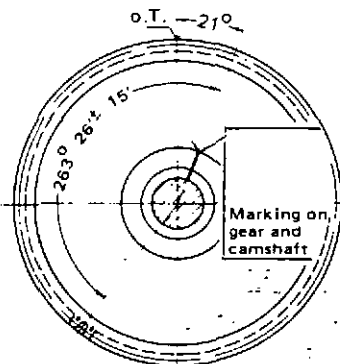

Fig. 2

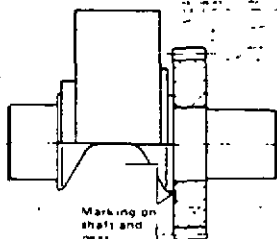

Fig. 3

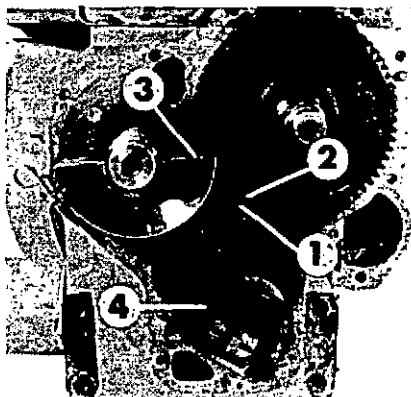

Fig. 4

The engine can run properly only if the gears are correctly timed.

The gears are properly timed when they are fitted to the corresponding shaft at the provided place with gear marks meshing with one another.

Please observe the following on gear assembly:

1. The D 302-1 crankshaft timing gear has a one-way bolt pattern to the crankshaft. All four bolt holes must be aligned prior to installing the bolts.
2. The D 302-2 and D 302-3 crankshaft timing gear is pinned axially to the crankshaft collar for proper alignment. (See Figure 1.)
3. The camshaft gear has a scribe mark which must align with the camshaft scribe mark for proper alignment. (See Figure 2.)
4. The D 302-1 counterweight has a "V" shaped notch which must align with the scribe mark on the face of the gear. (See Figure 3.)
5. The following procedures are for gear train timing.
 - a. Crankshaft to camshaft for all three engines: "0" mark on crankshaft gear tooth must align between "00" marks on camshaft gear teeth.
 - b. D 302-1 counterweight: The "1" mark on the crankshaft gear tooth must align between the two chamfered teeth located on the back side of the counterweight gear. **DO NOT** use the scribe mark on the front of the gear for gear train timing.
 - c. There are no timing marks for the oil pump and therefore it may be placed in any position.

NOTE: The camshaft gear, D302-1 counterweight gear and D302-2 and D302-3 crankshaft gears are a shrink fit and therefore must be heated to 220°C (425°F) prior to installation.

6.8 Adjusting gear backlash

Gear pairs	mm	(inches)
Oil pump/crankshaft		
Working position	0.2	.008
Engine on its head	0.3	.012
Oil pump/crankshaft*	0.11-0.27 ¹⁾	.005-.010 ¹⁾
Counterweight/crankshaft*	0.11-0.27 ¹⁾	.005-.010 ¹⁾
Camshaft/crankshaft	.011-0.27 ¹⁾	.005-.010 ¹⁾
Camshaft/hydraulic pump	0.11-0.27	.005-.010

*for D 302-1 only

¹⁾ control dimension only, non-adjustable

6.9 Checking piston clearance (dial indicator)

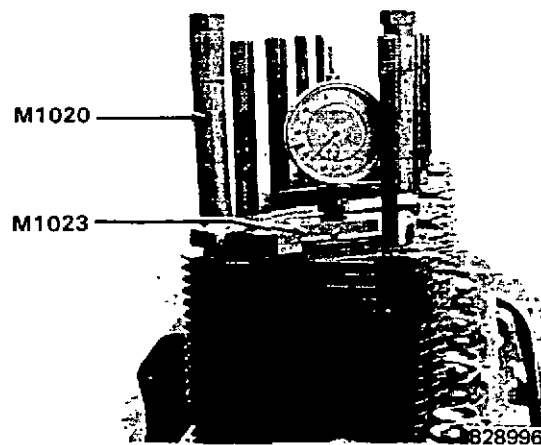

The piston clearance is the distance between the compression gasket surface of the finned cylinder and the top of the piston, **directly over the piston pin bore**. This clearance is established using the M 1020 hold-down and M 1023 dial indicator assembly. The specification is as follows:

minimum 4.60 mm (.181")
maximum 4.80 mm (.189")

The clearance is adjusted by shims located under the finned cylinder.

If the clearance is less than 4.60 mm, remove shim(s). If the clearance is greater than 4.80 mm, add shims. Shims are available in 0.1 and 0.2 mm thickness.

NOTE: The M 1023 indicator will need to be "zeroed" on a flat surface prior to measuring.

6.10 Compression clearance (lead wire check)

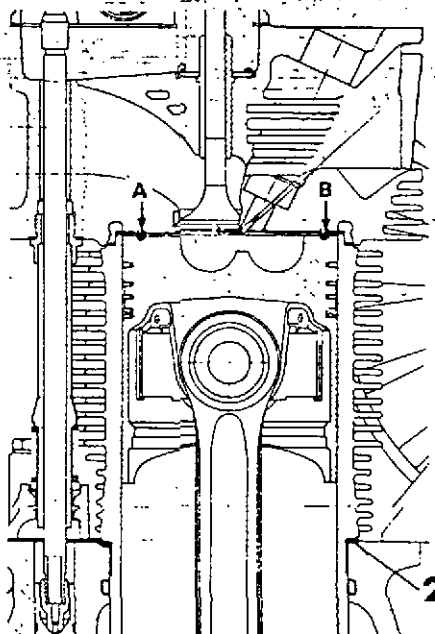

An alternate method of checking piston clearance is to check compression clearance using lead wire (solder).

The compression clearance is to be checked as follows:

1. Remove cylinder head.
2. Position 2 mm dia. lead wire at locations marked A and B.
3. Reinstall head and torque (see special torque specifications).
4. Slowly crank engine by hand until piston has passed top dead center.
5. Remove cylinder head and measure the compressed thickness of lead wires.
6. The average thickness of the lead wires must be:
min. 0.9 mm (.036")
max. 1.2 mm (.047").
7. If results exceed these tolerances, add or remove corresponding shims beneath finned cylinder. If there are no shims beneath the finned cylinder and the results exceed 1.2 mm (.047"), check cylinder head gasket, rod bearing clearance, pin bushing clearance and connecting rod straightness.

6.11 Fuel Injection Pump Timing

Required special tools:

- M 2001 Nozzle tester
- M 2010 Degree decal set
- M 2020 Pressure line kit
- M 2021 TDC tool
- M 2022 Pump rack tool

1. Check valve clearance .2 mm (.008").
2. Establish an accurate Top Dead Center (TDC).
 - a. Disconnect battery cables.
 - b. Remove belt guard.
 - c. Select a favorable cylinder on which the timing procedure will be performed and remove the valve rocker cover.
 - d. Viewing engine from the front, rotate crankshaft clockwise until the intake valve opens by approximately 5-6 mm (1/4").
 - e. Using the valve cover bolt, install M 2021 TDC tool on the rocker arm bracket and turn the bolt on the tool so that it will come in contact with the end of the rocker arm. This will hold the intake valve open 5-6 mm (1/4"). See Figure 1.

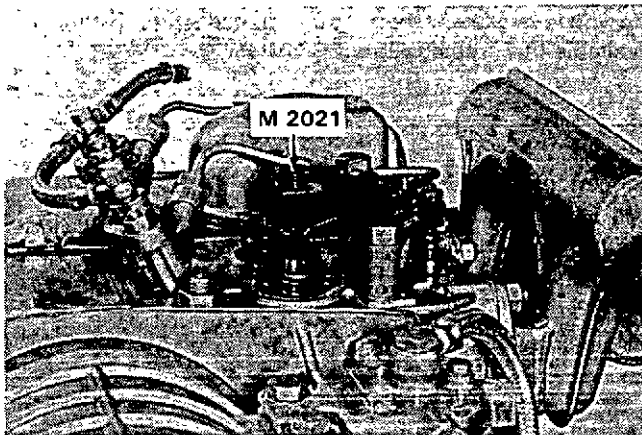

Figure 1

- f. Fabricate and install a reference pointer over the front crankshaft pulley. (On D 302-1, remove cooling air inlet screen, opposite starter side, and install a reference pointer on the center screen bolt so as to reference the front surface of the flywheel.)
- g. Rotate the crankshaft counterclockwise until the piston LIGHTLY contacts the valve. Using the reference pointer, mark the front crankshaft pulley. See Figure 2. (On D 302-1, mark the flywheel.)
- h. Rotate the crankshaft clockwise until the piston again LIGHTLY contacts the valve. Using the same reference pointer, mark the front crankshaft pulley. See Figure 3. (On D 302-1, mark the flywheel.)
- i. Measure the diameter of the pulley and from the M 2010 degree decal set select a decal that matches the diameter of the pulley. (On D 302-1 use M 2018 285 mm decal.)

- j. Without removing the backing from the decal, position it equally between the two reference marks and mark the pulley over the TDC/0° line on the decal. This will split the difference between the two reference marks, which is Top Dead Center (TDC). See Figure 4.

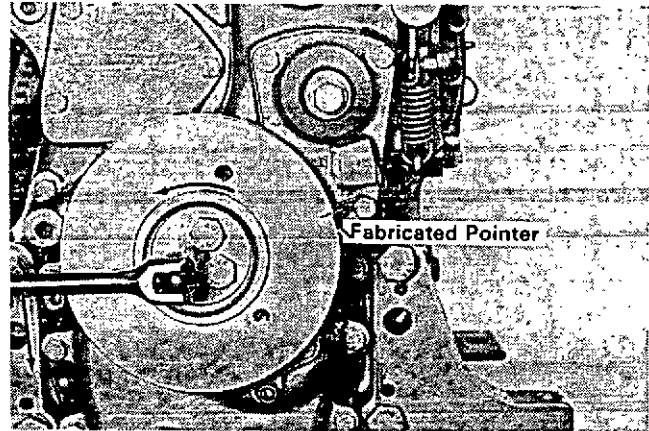

Figure 2

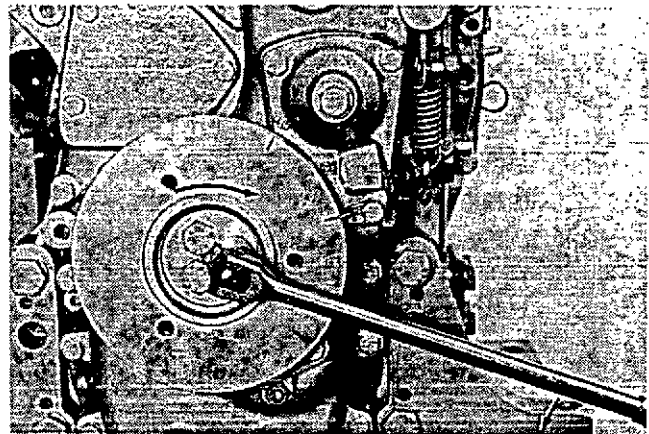

Figure 3

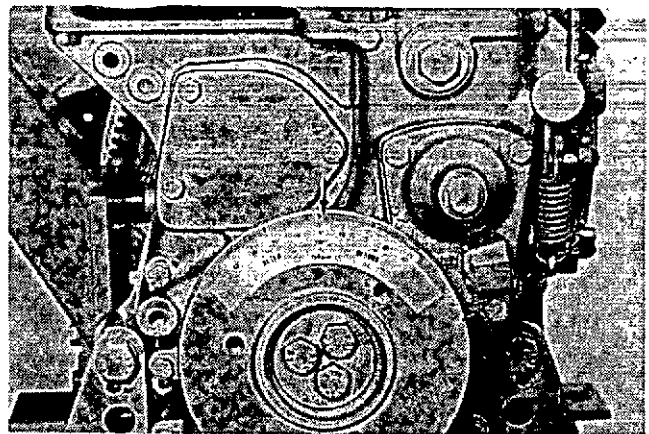

Figure 4

- k. Remove the backing from the decal and position the TDC/0° line over the center mark on the pulley.

3. Verify a true TDC (or recalibrate the pointer).

- a. Rotate the crankshaft clockwise until the piston LIGHTLY contacts the valve. Note the reading on the decal.
- b. Rotate the crankshaft counterclockwise until the piston again LIGHTLY contacts the valve. Note the reading on the decal.
- c. The reading in Steps a. and b. should be the same. For example, if Step a. is 18° before TDC, then Step b. should be 18° after TDC. In the event that the Step a. reading is different than the reading from Step b., divide the difference in half and move the pointer to the new setting. For example, if Step a. is 18° before TDC and Step b. is 22° after TDC, the difference in the two readings is 4° and divided in half is 2° . Move the pointer 2° so that it will read 20° after TDC. Then rotate the crankshaft clockwise until the piston LIGHTLY contacts the valve. The reading should be the same. In this example, it should read 20° before TDC.

4. Back out the bolt which is holding the intake valve open on the M 2021 TDC tool and then remove the tool.

5. Take note that there are two Top Dead Centers (TDC). With the TDC/ 0° line aligned with the pointer, there will be a:

- a. TDC exhaust which can be noted by the movement of both intake and exhaust valve rocker arms (push rods will be tight);

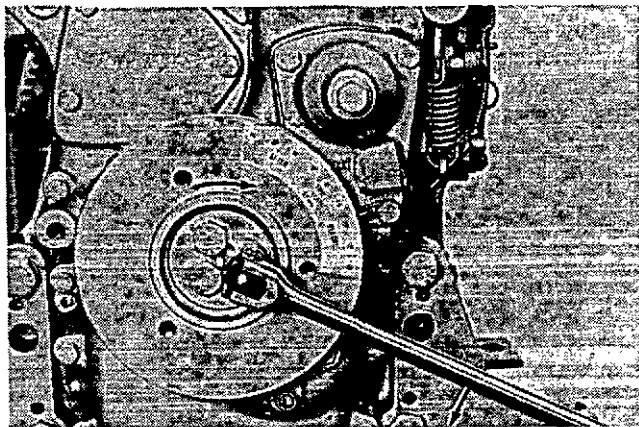

Figure 5

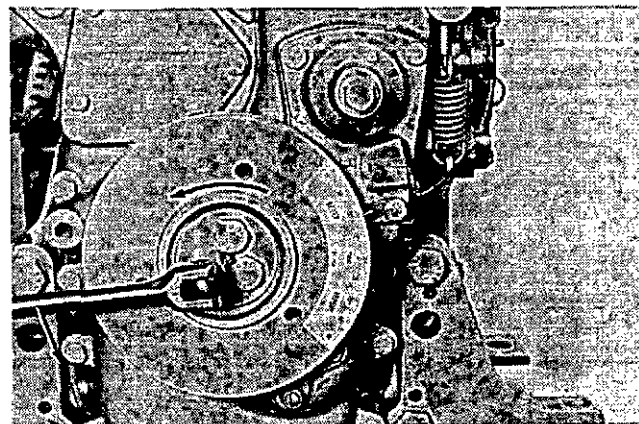

Figure 6

- b. TDC compression which can be noted by no movement of the intake and exhaust valve rocker arms (push rods will be loose).

6. Rotate the crankshaft so that it will read 40° to 50° before TDC compression.

7. Attach line kit M 2020 to M 2001 nozzle tester and install the 12 mm banjo adapter to the end of the high pressure line. With the valves on the nozzle tester in the following positions, pump the lever to bleed out the high pressure line before attaching it to the injection pump.

Pump isolator valve — OPEN
On/Off valve — CLOSED
Gauge protector valve — CLOSED

8. On the injection pump, remove the high pressure line that corresponds to the cylinder for which TDC was found and install the drip tube (part of M 2020 line kit). See Figures 7 and 8.

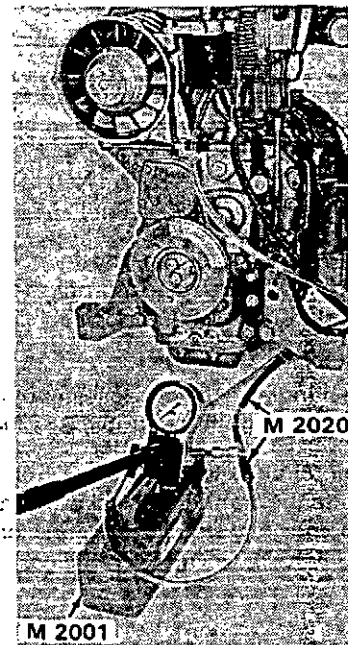

Figure 7

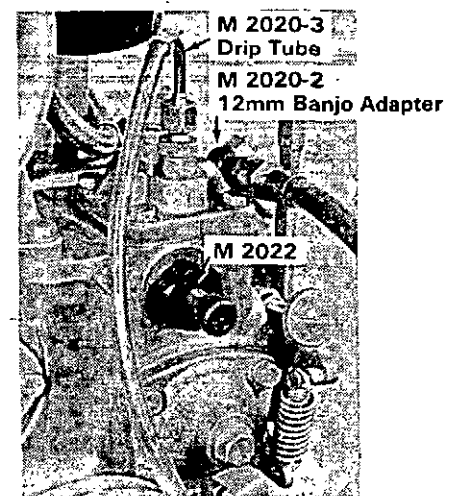

Figure 8

9. Also on the injection pump, remove the low pressure feed line and, using new copper gaskets, install the high pressure line from the nozzle tester. See Figures 7 and 8.

WARNING: The M 2020 line kit contains a safety valve set for 41 bar (600 psi). Tampering with this safety valve could do damage to the injection pump and in turn could cause personal injury.

NOTE: The high pressure lines and fuel injection nozzles will need to be connected to the remainder of the fuel connectors on the injection pump.

10. Remove the screw plug, located in front of the injection pump, from the front wall cover.
 - a. On Version I and II governors, push the injection pump control rack into the pump so that it will not be in "Start-Fuel" position.
 - b. On Version III governors, which have automatic "Start-Fuel," install M 2022 pump rack tool in the screw plug hole and turn bolt in until it bottoms against the pump. See Figure 8.

NOTE: The "Start-Fuel" position on the D 302 block pumps will retard injection timing by approximately 12°. Do NOT time an injection pump in the "Start-Fuel" position.

11. Position throttle in mid-range position. This will insure that the pump control rack is not in the "No-Fuel" position. If left in "No-Fuel" position, port closure will not take place.
12. Pump the handle on the nozzle tester until bubble-free fuel emerges from the drip tube. See Figure 9.
13. While maintaining a free flow of fuel from the drip tube, gently rotate the crankshaft clockwise until this flow of fuel just comes to a stop. This is port closure, which is the point at which fuel injection begins. See Figure 10.

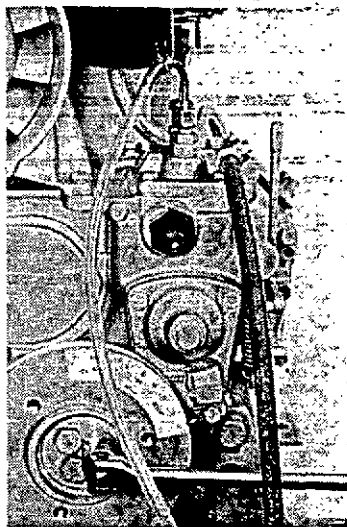

Figure 9

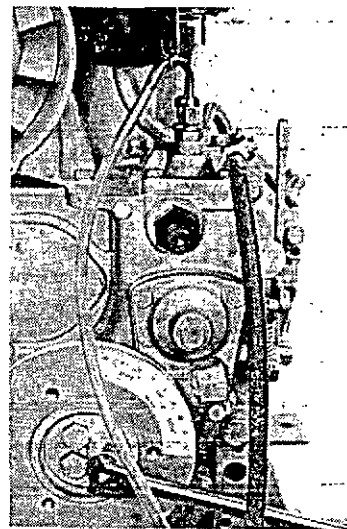

Figure 10

14. Note the reading on the degree decal. It should read:

D 302-1 23° BTDC + 2°
 D 302-2 25° BTDC ± 1°
 D 302-3 25° BTDC ± 1°

15. Pump timing is adjusted by the use of shims placed under the pump mounting flange. Raising the pump (by adding shims) retards injection timing, while lowering the pump (by removing shims) will advance injection timing. A .1 mm change in pump height will alter timing by 1°. Shims are available in .2 mm and .3 mm thicknesses. See Figure 11. For additional installation dimension information, see item #5.2.34 in Section 5.

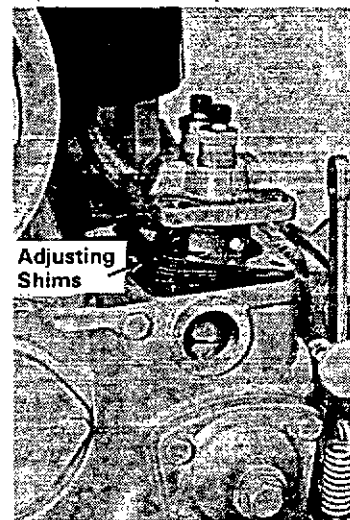

Figure 11

16. Bleed off any excess pressure left in the high pressure line by opening the On/Off valve on the nozzle tester before removing the line kit from the injection pump.
17. When using the front crankshaft pulley bolts or flywheel bolts for rotating the crankshaft, check torque on these bolts. Refer to "Special Torque Specs."

CAUTION: Failure to check torque on crankshaft pulley bolts or flywheel bolts could result in serious engine damage.

NOTE: The M 2010 degree decal set consists of ten (10) different diameters designed to be used on front crankshaft pulleys. The larger diameter decals can be used on the rear face of the flywheels; however, the "Before" and "After" will be reversed. The ten different diameters are as follows:

TOOL NUMBER

SIZE

	mm	inches
M 2011	142	(5-9/16)
M 2012	165	(6-1/2)
M 2013	195	(7-11/16)
M 2014	210	(8-1/4)
M 2015	230	(9-1/16)
M 2016	270	(10-5/8)
M 2017	320	(12-5/8)
M 2018	285	(11-1/4)
M 2019	275	(10-13/16)
M 2035	320	(12-5/8)

6.12 GOVERNOR ADJUSTMENTS

The Version III governor differs from the Version I and II governors in that it contains two (2) springs whereas Versions I and II contain only one (1). The addition of the second spring eliminated the "start-fuel" button on the injection pumps used with the Version I and II governors. This gave the Version III governor an "automatic" start-fuel feature during start-up which is advantageous for remote start applications.

There are five (5) governor adjustments:

1. HIGH IDLE (MAXIMUM NO LOAD) R.P.M.
2. LOW IDLE R.P.M.
3. START-FUEL
4. STOP-LIMIT
5. THROTTLE LOCK (Version I and II)
MAXIMUM FULL LOAD HORSEPOWER (Version III)

Refer to Figures 1 and 2 for their location.

Start-Fuel and Stop-Limit should be adjusted before starting the engine, whenever an injection pump, front wall cover, or any internal governor components have been removed and replaced.

Below are the procedures for adjusting the governor.

1. HIGH IDLE (Maximum No Load) R.P.M.

The maximum full load R.P.M. is found on the engine name plate. The high idle R.P.M. should be adjusted to 3 - 5% above the maximum full load R.P.M.

The high idle adjusting screw is located behind the throttle lever on the front wall cover, Figures 1 and 2. This adjustment is commonly sealed with a strap and lead wire. There is an eccentric disc on the end of this adjusting screw (Figures 1, 2 and 3) which will require a maximum of one (1) turn to change this setting from minimum to maximum.

NOTE: When this screw is turned in or out too far, the internal throttle lever will miss the eccentric disc which can cause governor instability in the upper R.P.M. range. This can be corrected by:

1. Remove the camshaft cover. This will gain visual contact to the following adjustment.
2. Turn the high idle screw in or out so that the internal lever will contact the eccentric disc when the external lever is placed in the maximum speed position, Figure 3.
3. Replace camshaft cover.
4. Adjust the high idle and secure it with the jam nut.
5. Seal the high idle adjustment.

The operating speed range of the engine is controlled by the governor control spring (spring B on Version III). There are five (5) different springs, each calibrated for a specific R.P.M. range (see spring chart). Using a spring in an R.P.M. range that it is not designed for can result in governor instability with the speed above the range of the spring or excessive droop below the speed range of the spring.

When changing the speed range of the engine, stamp the new maximum full load R.P.M. on the engine name plate.

On Version I and II governors, the governor control spring can be replaced without removal of the front wall cover. Spring replacement can be accomplished by removing the camshaft cover and using a pair of duckbill pliers (Snap-On #61-CP or equivalent) through the access to unhook the spring. The throttle lever should be placed in the shut-down position. Extreme care should be exercised so as not to damage the spring by bending or stretching. A safety wire should also be used to prevent the spring from falling into the engine after it is unhooked.

On Version III governors, the front wall cover must be removed when replacing the governor control spring.

NOTE: Change only the governor control spring B, Figure 2. The start spring, A, stays the same for all speed ranges.

Replacing the governor control spring:

1. Remove any accessories and accessory drive pulleys which are attached to the front wall cover.
 2. On D 302-2 and D 302-3, remove the front crankshaft pulley. On D 302-1, remove the accessory drive pulley or cover.
 3. Remove camshaft cover.
 4. Remove camshaft nut. (Note left-hand thread.)
 5. Remove fuel feed pump.
 6. Remove fuel injection pump.
 7. On D 302-2 and D 302-3, remove 4 oil pan bolts which are attached to the front wall cover.
 8. Remove the bolts attaching the front wall cover to the cylinder block.
 9. Using a suitable tool, pry the front wall cover from the cylinder block. Take notice that the front wall cover is located on the block by 2 dowels.
- NOTE:** The camshaft should stay in the cylinder block. It may be necessary to tap the end of the camshaft with a rubber mallet while removing the front wall cover.
10. Remove the camshaft bearing from the front wall cover.
 11. Disassemble governor in front wall cover to change the spring. Using pliers to install the new spring will increase the chance of damage to the spring.
 12. Replace front wall cover gasket.
 13. On D 302-2 and D 302-3, apply a small bead of RTV sealant in the corners of pan and cylinder block.
 14. ENSURE THE GOVERNOR WEIGHTS AND GOVERNOR SHAFT ARE STILL IN POSITION ON THE OIL PUMP.
 15. On D 302-1, ensure correct timing of the counterweight. (See section 6.7 on setting gear train timing.)

16. Using guide studs, install front wall cover and install bolts.
17. Using an even pattern, torque all front wall cover bolts to 25 Nm (18 lb.-ft.).
18. Install the camshaft bearing.
19. Using a new gasket install fuel feed pump.
20. With the same number of shims that were removed with the fuel injection pump in step 6, install the injection pump. Ensure pump rack is in the fork of the governor lever. Torque bolts to 25 Nm (18 lb.-ft.).
21. Adjust Start-Fuel (see adjustment #3).
22. Adjust Stop-Limit (see adjustment #4).
23. Install front crankshaft pulley and torque bolts to 120-125 Nm (89-92 lb.-ft.).
24. On D 302-2 and D 302-3, install front crankshaft pulley (note one-way bolt pattern) and torque bolts evenly to 120-125 Nm (89-92 lb.-ft.). On D 302-1, torque counterweight bolt to 50-60 Nm (37-44 lb.-ft.).
25. Install any accessories that were removed earlier.
26. Start engine and adjust low and high idle.

2. LOW IDLE R.P.M.

Minimum idle speed is 650 R.P.M.

The low idle adjustment is located on the throttle lever. Figures 1 and 2. The adjusting screw 2, contains a spring loaded pin that will allow shut-down when the throttle lever is forced past the low idle position.

NOTE: Some throttle lever arrangements do not have a low idle adjustment.

3. START-FUEL

- 1 Cylinder engines = 11.2 ± .2 mm (.441 ± .007")
- 2 Cylinder engines = 7.0 ± .2 mm (.275 ± .007")
- 3 Cylinder engines = 7.0 ± .2 mm (.275 ± .007")

The difference between Version I and II can be seen by the location of the start-fuel adjustment (adjustment #3), Figure 1. The start fuel adjusting screw in the Version I governor is eccentric. One (1) turn is all that is required to move this adjustment minimum to maximum. If this screw is turned in too far, the governor lever will bind in the front wall cover. When turned out too far, this lever will bind against the pump. After making the start-fuel adjustment, always check for free rack movement. Failure to do this could result in dangerous engine overspeed.

The start-fuel adjusting screw, on Version II and III, is located on the bottom of the governor control lever (Figures 1 and 2). The measurement for all three versions is taken with a depth micrometer between a machined surface on the front wall cover and the end of the injection pump rack, Figure 5.

Misadjustment of start-fuel can result in one or more of the following:

1. Hard Starting.
2. Low Power.
3. Governor Instability (surging).
4. Change in Droop.

CAUTION: Under no circumstances should start-fuel adjustment be performed on a running engine.

Adjusting Start-Fuel

1. Remove the belt guard from the front of the engine (if equipped).
2. Remove the front crankshaft pulley.
3. Located on the front of the front wall cover, remove the following 3 items (Figure 3):
 - A. Cover plate.
 - B. Camshaft cover (Version III ONLY).
 - C. Screw plug and copper gasket.
4. Ensure the machined surface from which the screw plug was removed is clean and free of paint, dirt and burrs (Figure 4).
5. Position throttle in the maximum speed position.
6. Using the depth micrometer, measure the distance from the end of the pump rack to the surface of the front wall cover (Figure 5). The dimension is listed above.
7. To correct the setting, loosen the jam nut on the start-fuel adjusting screw with tool M 2023 (Figure 3).
8. Turning the start-fuel adjusting screw clockwise will increase the setting while counterclockwise will decrease it.
9. While holding the adjusting screw, tighten the jam nut with tool M 2023.
10. Recheck start-fuel setting.
11. Position throttle in the shut-down position.
12. Adjust stop-limit (see adjustment #4).
13. With new gaskets, install the cover plate and camshaft cover. Torque bolts to 25 Nm (18 lb.-ft.).
14. Using a new copper washer, install screw plug.
15. Install front crankshaft pulley and torque bolts to 120-125 Nm (89-92 lb.-ft.).
16. Install belt guard (if equipped).
17. Start engine and adjust the low and high idle speeds.

4. STOP-LIMIT

All models = .5 mm (.020") before the fuel injection pump control rack bottoms in the pump.

The stop-limit adjusting screw is located on the front wall cover, just below the cover plate (Figures 1, 2 and 3).

CAUTION: The stop limit adjusting screw should be backed out prior to adjusting the governor. If this screw is turned in too far, it will override the governor weights and could cause dangerous engine overspeed.

CAUTION: Under no circumstances should stop-limit adjustment be performed on a running engine.

Adjusting stop-limit

1. Remove belt guard from the front of the engine (if equipped).
2. Remove screw plug and copper gasket.
3. Ensure the machined surface from which the screw plug was removed is clean and free of paint, dirt and burrs (Figure 4).
4. Position throttle in the shutdown position.
5. After loosening the lock nut, back out the stop-limit adjusting screw several turns (Figure 3).
6. Lay the base of a depth micrometer on the surface of the front wall cover from where the screw plug was removed (Figure 5). Using the probe on the depth micrometer, bottom the control rack in the injection pump.
7. Note the reading on the depth micrometer and subtract .5 mm (.020") from that reading [e.g., if a reading of 23.36 mm (.920") was obtained with the rack bottomed, the micrometer will then be adjusted to read 22.86 mm (.900")].
8. Position the depth micrometer over the end of the control rack and front wall cover (as in step 6). Turn in the stop-limit adjusting screw until the control rack just starts to lift the base of the depth micrometer away from the front wall cover.
9. Tighten the lock nut.
10. Using a new copper washer, install a screw plug.
11. Install belt guard (if equipped).
12. Start engine and adjust low idle.

5. THROTTLE LOCK (VERSION I AND II) Ref. Figure 1.

This (M8 x 1.25) adjusting screw when turned in all the way will "lock" the internal throttle lever against the eccentric disc on the maximum speed adjusting screw. This will result in the engine running at maximum governed speed with no means of slowing it down.

This screw can also act as a low speed adjustment for a dual speed application. This is accomplished by turning the screw in until the desired low speed is reached.

This screw is generally left "backed-out" as with either situation mentioned above, normal means of shut-down (use of the external throttle lever) will be eliminated when used.

5. MAXIMUM FULL LOAD HORSEPOWER (VERSION III) Reference Figure 2.

This adjusting screw is an M14 x 1.5 which is not interchangeable with Version I and II. This adjustment will require a dynamometer. Refer to the performance curves for specifications.

The maximum full load horsepower adjusting screw is located on the camshaft cover (Figures 2 and 3). Turning this screw IN will decrease the fuel output of the pump while backing it OUT will increase it.

Seal the M.F.L. horsepower adjusting screw after adjustment.

DO NOT USE THIS ADJUSTMENT TO CURE A LOW POWER COMPLAINT.

NOTE: Warranty will not cover engine damage due to over-fueling.

Low power is generally caused by the following:

1. Misadjusted throttle linkage.
2. Dirty air filter.
3. Dirty fuel filters (include screen in fuel-feed pump).
4. Valve clearance.
5. Faulty injection nozzles.
6. Fault on low-pressure side of fuel system (e.g., air, fuel feed pump, etc.).
7. Low compression.
8. Faulty injection pump (includes pump timing).
9. High exhaust back pressure.
10. Engine under-powered for application.

Over-fueling will cause high exhaust temperatures. This in turn will cause high cylinder temperatures which will decrease engine life. A high exhaust back pressure will also cause high exhaust temperatures. Refer to the Technical Data section under "Exhaust System" for specifications.

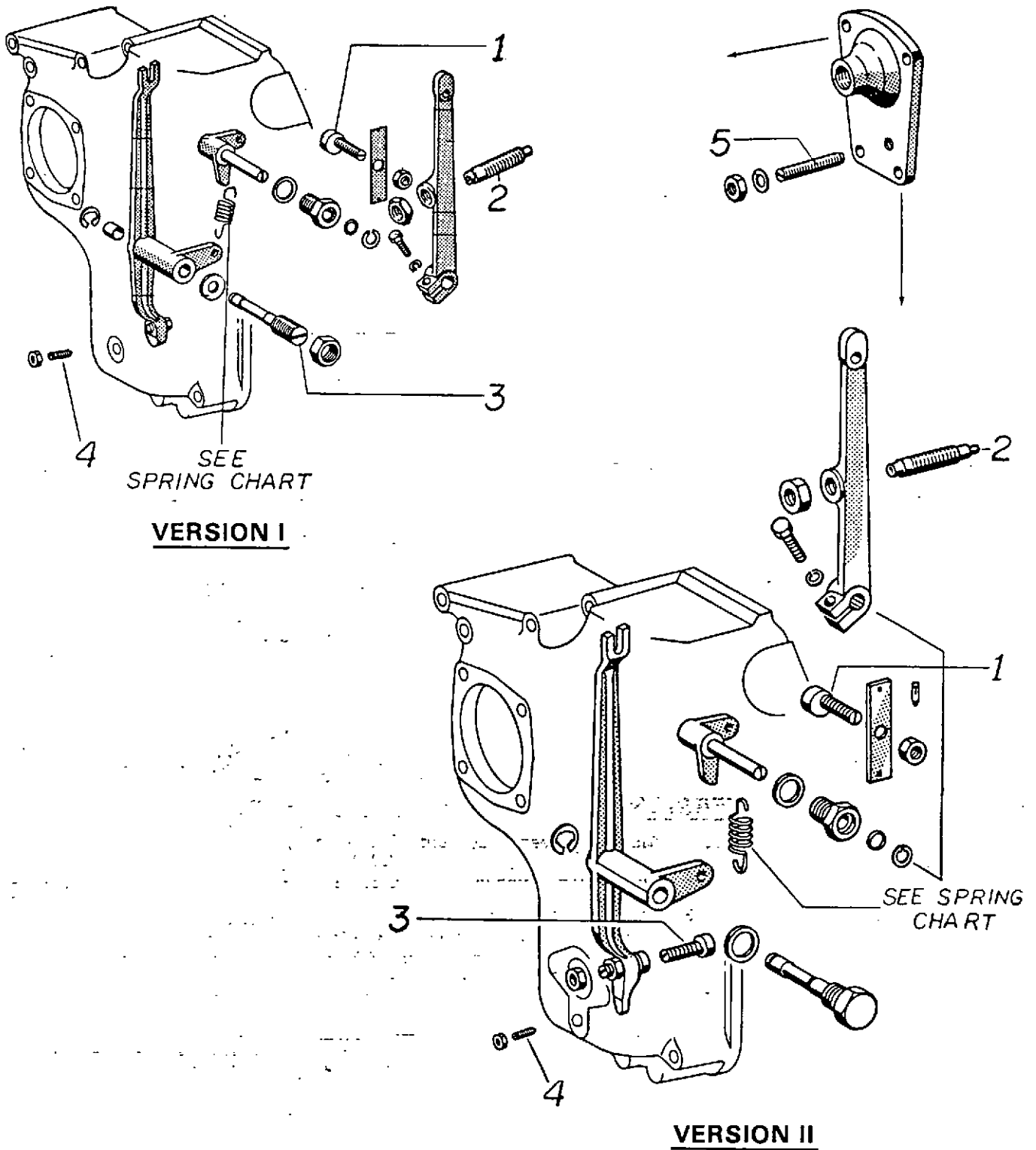

SEE
SPRING
CHART

VERSION I

SEE SPRING
CHART

VERSION II

- | | |
|--|--|
| <ul style="list-style-type: none"> 1. Maximum speed adjustment. 2. Idle speed adjustment. 3. Start-fuel adjustment <ul style="list-style-type: none"> 1 Cylinder = $11.2 \pm .2$ mm ($.441 \pm .007$") 2 Cylinder = $7.0 \pm .2$ mm ($.275 \pm .007$") 3 Cylinder = $7.0 \pm .2$ mm ($.275 \pm .007$") | <ul style="list-style-type: none"> 4. Stop-limit adjustment
All Models = .5 mm (.020") 5. Throttle lock for constant speed applications or low speed adjustment for "dual range" applications. (When adjusted, other means of normal shutdown will be required.) |
|--|--|

Figure 1

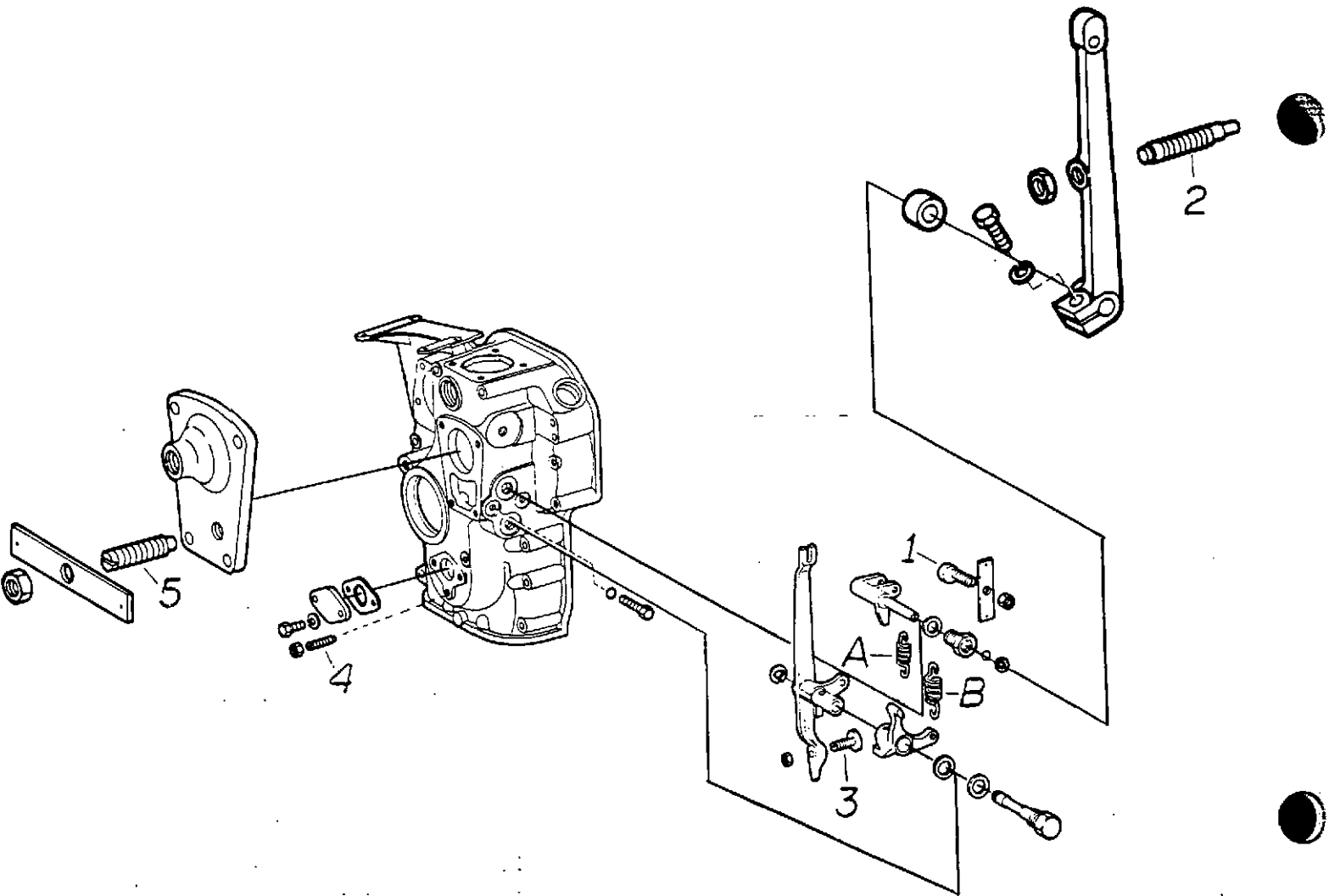

VERSION III

1. Maximum speed adjustment.
 2. Idle speed adjustment.
 3. Start-Fuel adjustment
 - 1 Cylinder = $11.2 \pm .2$ mm ($.441 \pm .007$ ")
 - 2 Cylinder = $7.0 \pm .2$ mm ($.275 \pm .007$ ")
 - 3 Cylinder = $7.0 \pm .2$ mm ($.275 \pm .007$ ")
 4. Stop-limit adjustment
All Models = .5 mm (.020")
 5. Maximum full load horsepower adjustment will require dynamometer for adjustment.
- A. Start spring
B. Governor Control Spring } (See Spring Chart)

Figure 2

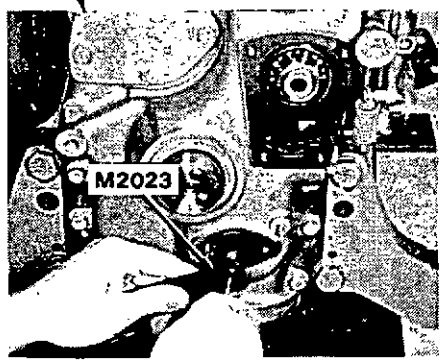
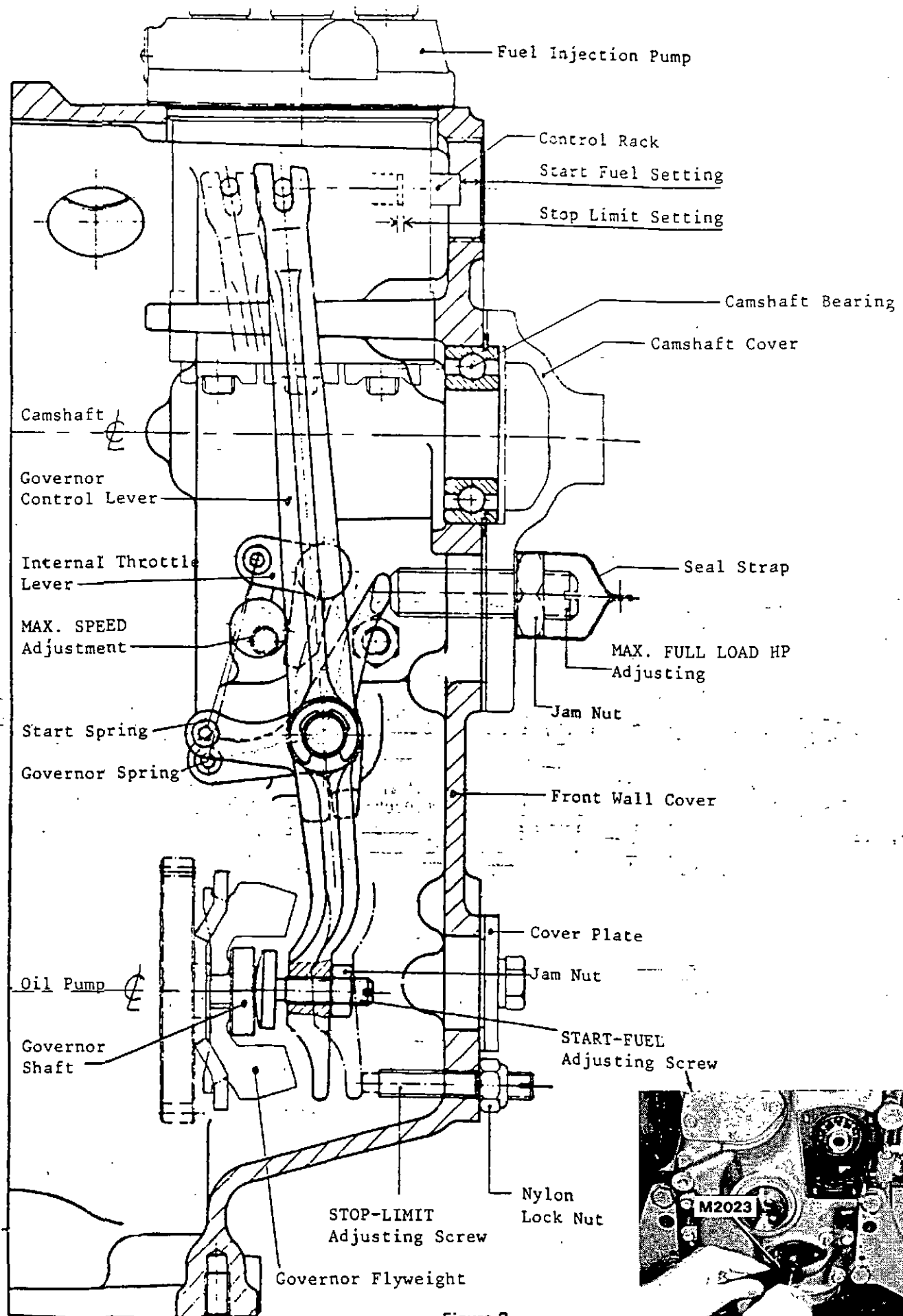

Figure 3

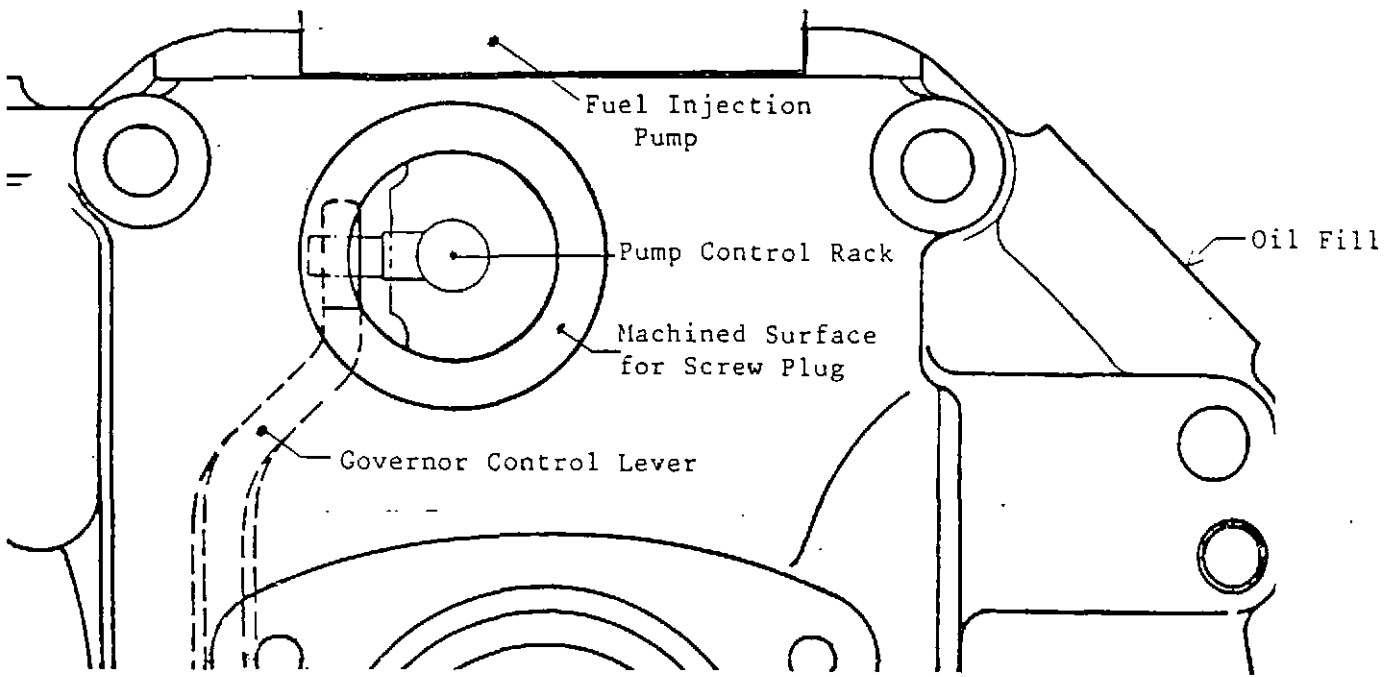
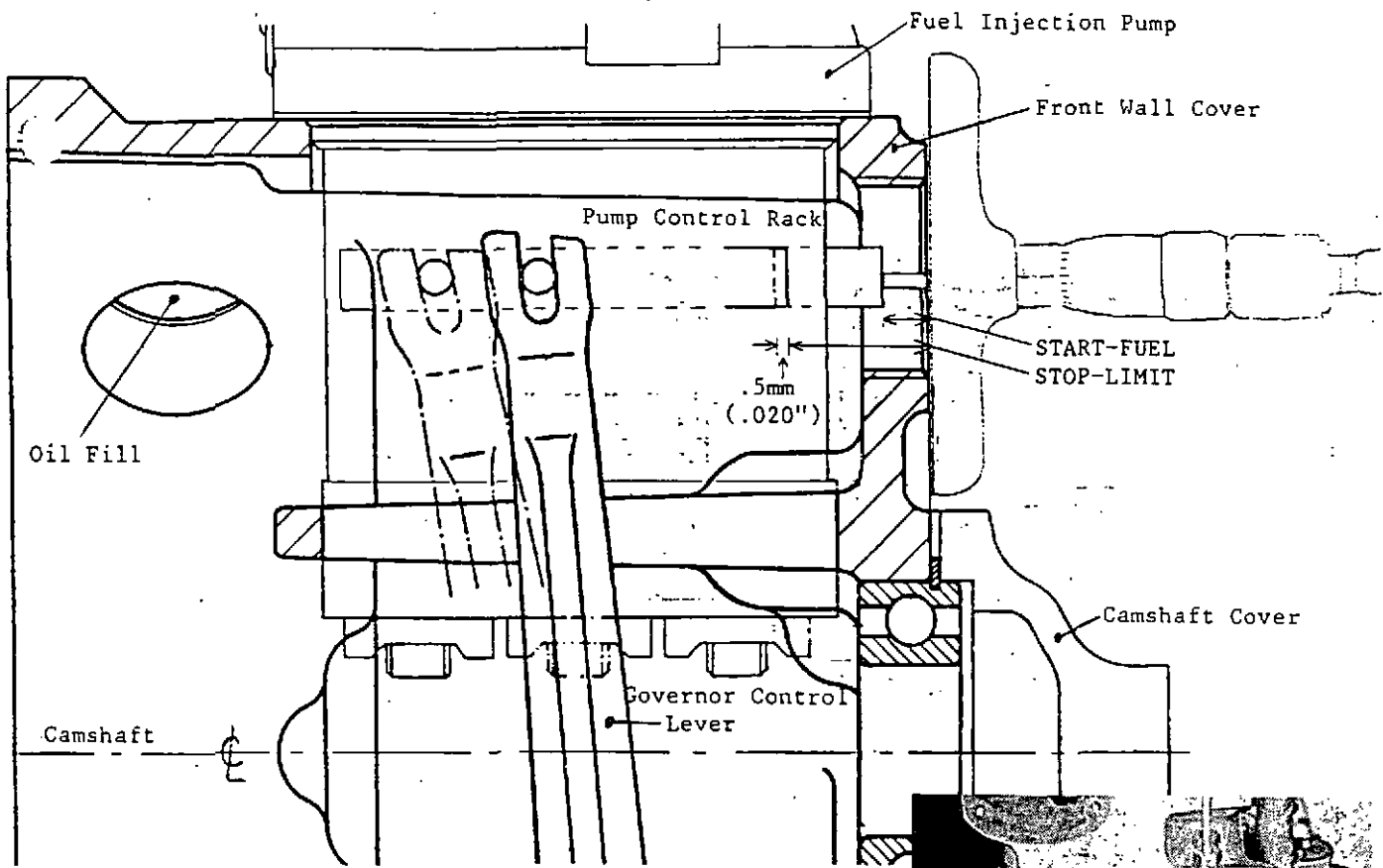

Figure 4

UPPER FRONT VIEW OF FRONT WALL COVER



SIDE CUT-AWAY VIEW OF FRONT WALL COVER

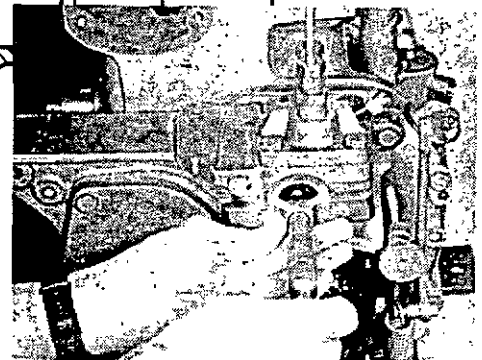

Figure 5

GOVERNOR SPRING CHART

PART NUMBER	R.P.M. RANGE	NO. COILS	WIRE DIA. (mm)	COIL DIA. (O.D.)(mm)	FREE LENGTH (mm)	TENSION (lb./mm)
VERSION I & II						
6.0242.12.0.2560	1500 - below	6.5	1.6	13.9	44.00 ± .25	10.4 ± .7/52.46
6.0242.12.0.2810	1500 - 1800	7.5	1.8	14.0	44.00 ± .25	14.6 ± 1.1/52.2
6.0242.12.0.1100	1800 - 2000	6.5	1.8	13.7	44.00 ± .25	17.6 ± 1.2/52.0
6.0242.12.0.1150	2000 - 2500	6.5	2.0	13.8	44.00 ± .25	26.4 ± 1.8/51.9
6.0242.12.0.1220	2500 - 3000	6.5	2.25	14.55	44.00 ± .25	38.8 ± 4.3/52.0
VERSION III						
6.0242.12.0.2360	Start Spring	6.5	1.4	13.2	44.00 ± .25	7.5 ± .7/53.00
6.0242.12.0.2780	1500 - below	7.5	1.8	14.0	50.00 ± .25	15.9 ± 1.1/59.0
6.0242.12.0.1130	1500 - 1800	7.5	2.0	14.0	50.00 ± .25	26.1 ± .8/59.00
6.0242.13.0.1160	1800 - 2000	7.5	2.25	15.05	50.00 ± .25	33.9 ± 2.4/59.0
6.0242.15.0.1280	2000 - 2500	6.5	2.8	17.8	50.00 ± .25	57.2 ± 3.4/59.0
6.0242.14.0.1460	2500 - 3000	6.5	3.0	17.4	50.00 ± .25	85.6 ± 5.1/59.0

6.13 Renewing seal in rear wall cover (flywheel end)

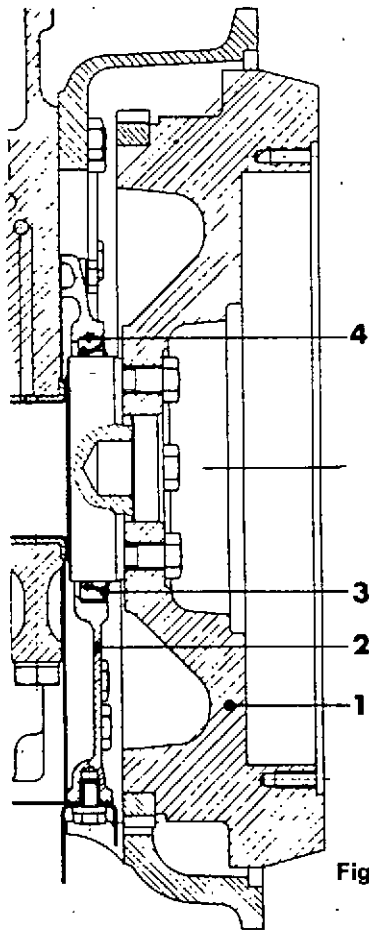

Fig. 1

Fig. 1

- 1 Flywheel
- 2 Rear wall cover
- 3 Shaft seal
- 4 Seat in cover

Removal

- Unscrew flywheel (1, Fig. 1).
- Unscrew rear wall cover (2, Fig.1) with sealing ring.
- Press shaft seal out (3, Fig. 1), making sure not to damage seal seat in cover (4, Fig. 1).

Checking

Examining crankshaft flange for wear :

Test result A	Action
No appreciable wear (finger-nail check) less than 1 mm (.040") wide	Clean running surface of crankshaft flange and polish with very fine emery cloth to remove rifling.
Test result B Appreciable wear (finger-nail check) above 1 mm (.040") wide	Clean running surface of crankshaft flange and polish with very fine emery cloth to remove rifling. Fit shaft seal offset from previous position.

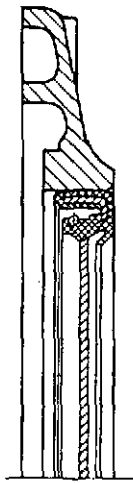

Fig. 2

Normal installation

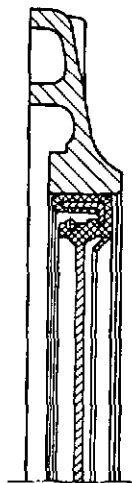

Fig. 3

Offset installation

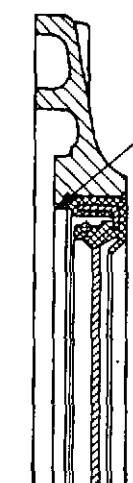

Fig. 4

Normal installation

with inner flange

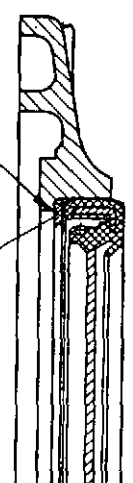

Fig. 5

Offset by shim

Installation of new seal in rear wall cover (flywheel end)

- Before beginning, apply thin film of grease to outside of seal and to sealing lip.

Action for test result A

Rear wall cover with inner flange or without:

- Using installation plate 6.206.0.690.005.4 with drift press, force seal fully home (Figs. 2 and 4).

Action for test result B

Rear wall cover with inner flange:

- Introduce shim 6.000.0.340.004.4, pressing seal fully home against shim (Fig. 5).

Rear wall cover without flange:

- Install seal offset by 2 mm (.079") inward so that contact surface of sealing lip is axially displaced (Fig. 3).

Apply thin film of grease to crankshaft flange around entire circumference.

Rear wall cover

- Fit with extreme caution.
- **IMPORTANT:** Be sure not to damage sensitive sealing lip.
- Bolt rear wall cover on.
- Attach flywheel, noting correct tightening torques (see section 6.4).

6.14 SERVICE NOTES

DIAPHRAM FUEL FEED LIFT PUMP

A number of fuel lift pumps have been returned for possible warranty that have a dirty screen, or with inlet port threads stripped or the wall cracked. There will be no warranty on these.

A dirty tank is the customer's responsibility; the screen can be cleaned. The Distributor, Service Dealer and customer should carry spare 6.0492.01.0.1420 copper gaskets. Copper works hard from tightening and retightening. New gaskets that are soft take less torque to seal.

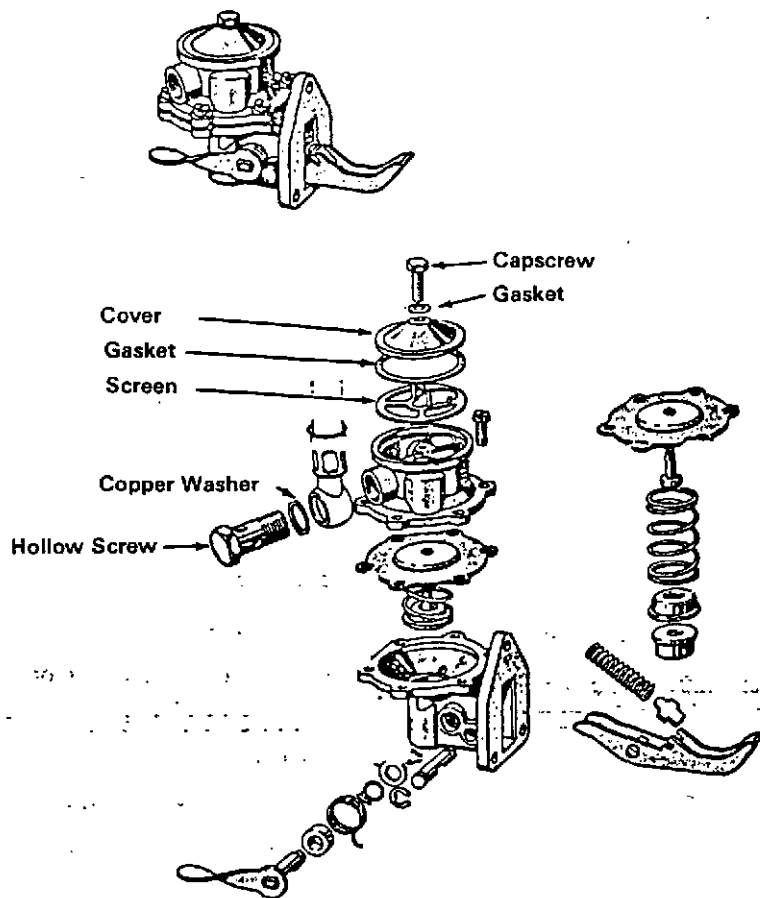

SERVICE NOTES (CONT.)

SEALED BEARINGS FOR D 302-3 COOLING BLOWERS

Blowers on new engines and repair part blower assemblies come equipped from Spain and Germany with 6.0320.04.5.6204 and 6.0320.07.3.6204 ball bearings. It is recommended that the bearings be checked and greased every 2,250 hours.

When bearing replacement becomes necessary, it is recommended that the 6.0320.04.5.6204 and

6.0320.07.3.6204 ball bearings be replaced with sealed bearings 463-5. It is still recommended that the bearings be checked every 2,250 hours.

Blower rebuild kit, M 5001, has been designed to rebuild both D 302-2 and D 302-3 cooling blowers.

SERVICE NOTES (CONT.)

THROTTLE SOLENOID SHUTDOWN FOR D 302-2 ENGINE

For electrical connection of the subject solenoid, refer to:

1. If D 302-2 engine is equipped with FEMSA generator and has small instrument panel with red, green and yellow warning lights, see page 20 for wiring diagram.
2. If D 302-2 engine is equipped with MOTOROLA alternator and has small instrument panel with red, green and yellow warning lights, see page 21 for wiring diagram.
3. If D 302-2 engine is equipped with MOTOROLA alternator and has large semi-automatic switch gauge instrument panel, see page 22 for wiring diagram.

NOTE: See LD104 Layout Diagram with part numbers on next page.

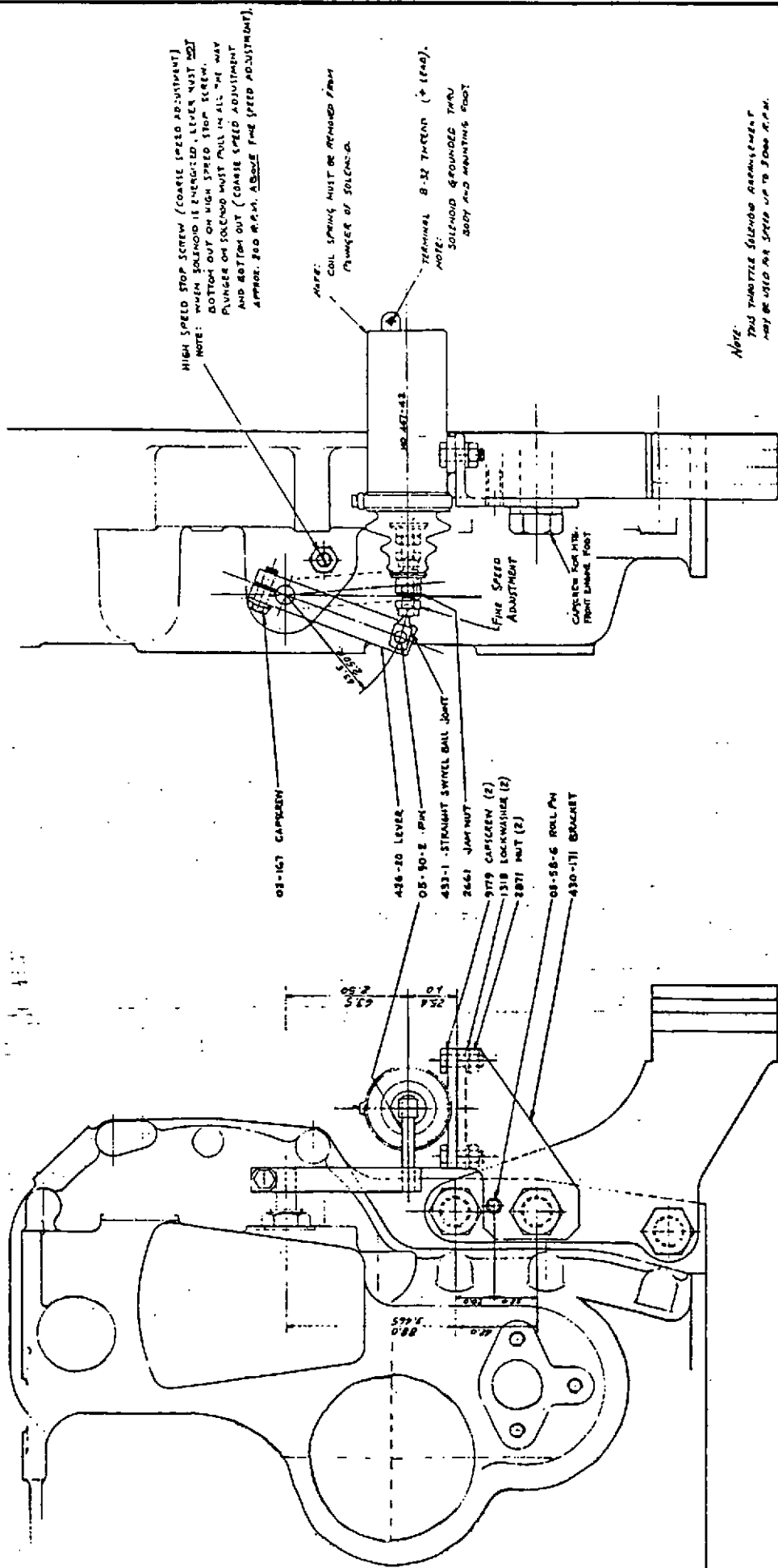

Note: THIS THROTTLE SOLENOID ASSEMBLY MAY BE USED AT SPEED UP TO 3000 R.P.M.

HIGH SPEED STOP SCREW (COARSE SPEED ADJUSTMENT)
 NOTE: WHEN SOLENOID IS ENERGIZED, LEVER MUST NOT
 BOTTOM OUT ON HIGH SPEED STOP SCREW.
 PLUNGER ON SOLENOID MUST FULL IN ALL THE WAY
 AND BOTTOM OUT (COARSE SPEED ADJUSTMENT
 APPROX. 200 R.P.M. ABOVE THE SPEED ADJUSTMENT).

NOTE: COIL SPRING MUST BE REMOVED FROM
 PLUNGER OF SOLENOID.

TERMINAL 8-32 THREAD (Ø 1.60).
 NOTE: SOLENOID GROUNDED THRU
 BODY AND MOUNTING FOOT.

- 03-167 CAPSCREW
- 438-20 LEVER
- 05-90-2 .071"
- 433-1 STRAIGHT SWIVEL BALL JOINT
- 2661 JAM NUT
- 9179 CAPSCREW (2)
- 1318 LOCKWASHER (2)
- 2871 NUT (2)
- 03-58-6 ROLL PIN
- 430-171 BRACKET

REV.	DATE	BY	CHKD.	DESCRIPTION
1				ISSUED FOR PRODUCTION
2				REVISION
3				REVISION
4				REVISION
5				REVISION
6				REVISION
7				REVISION
8				REVISION
9				REVISION
10				REVISION
11				REVISION
12				REVISION
13				REVISION
14				REVISION
15				REVISION
16				REVISION
17				REVISION
18				REVISION
19				REVISION
20				REVISION

7.0 TROUBLESHOOTING

	PAGE
7.1 Checking compression pressure	91
7.2 Testing fuel injection nozzles	92-93
7.3 Lube oil pressure	93
7.4 Lube oil consumption	93
7.5 Valve timing	94
7.6 Valve sealing	94
7.7 Fuel consumption	94
7.8 Troubleshooting charts	95-99
Engine won't start	95
Abnormal engine operation	96
Exhaust smoke	97
Lubrication system	98
Cooling air system	99

7.1 Check compression pressure

Required Special Tools:

M 3001 Compression Tester
M 3002 Adapter
6.0690.12.8.1017 Tip Gaskets

Compression is checked by means of the compression tester to establish whether adequate compression pressure is available. The tester is connected to the

opening for the injection valve in the cylinder head referring to illustrations below.

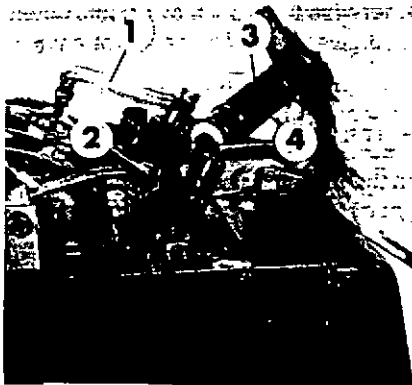

Sequence:

1. Remove leak off line 1.
2. Unscrew fuel delivery line 2 at injection nozzle.
3. Take down mounting bracket.
4. Withdraw injection nozzle 3. Note gasket 4.
5. Apply compression tester 5.
6. Insert chart 6.
7. Press speed governing lever to stop position.
8. Crank engine by hand or with starter (3-5 revolutions).
9. Minimum compression pressure: 22-25 bar (319-362 psi).
10. Causes of inadequate compression pressure:
 - leaky valves
 - leaky pistons
 - heavily scored finned cylinder
 - lead wire dimension too high
 - compression release adjustment (if equipped)
 - leaky injection nozzle tip gasket
 - leaky compression gasket
11. Remedy causes.

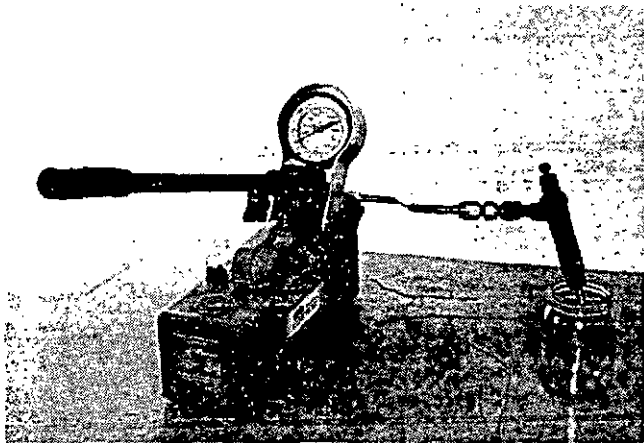

M 2001 (OTC Y-900) Nozzle Tester

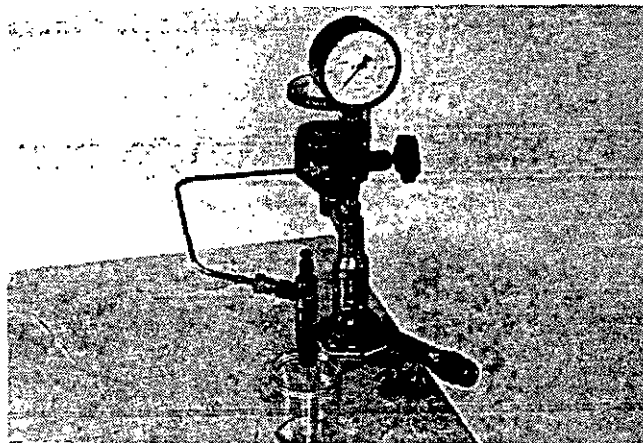

Robert Bosch Nozzle Tester

7.2 Testing Fuel Injection Nozzles

Require Special Tools

M 2001 Nozzle Tester (which includes the following)

OTC Y-900	Nozzle Tester
OTC Y-900-2A	Fuel Line Assembly
OTC Y-900-5	Adapter
OTC Y-900-7	Adapter Nut

Below are instructions for testing of fuel injection nozzles on the MWM-Murphy Diesel engines. For additional information on the general use of the Y-900 nozzle tester, refer to Form No. 102400 sent with each OTC nozzle tester.

There are four (4) tests to be performed on fuel injection nozzles. Before testing, air must be purged from the nozzle and connector hardware.

With the injection nozzle connected and the valves in the following positions, operate the pump lever rapidly to clear the connector line and injection nozzle of all air.

ON/OFF Valve	— Closed
Pump Isolator Valve	— Open
Gauge Protector Valve	— Closed

1. OPENING PRESSURE TEST

With the valves in the following positions, slowly operate the pump lever to bring system pressure up to a point where the nozzle just pops. Specifications are listed below.

ON/OFF Valve	— Closed
Pump Isolator Valve	— Open
Gauge Protector Valve	— Open

IMPORTANT Rapid operation of pump lever will result in inaccurate opening pressure readings as well as undue wear on the gauge.

Condiesel Injection Nozzles

Standard output engines (I.D. number on nozzle holder: CKBL88SD5270) 180-185 bar (2610-2680 psi).

High output engines (I.D. number on nozzle holder: CKBL88SD5459) 220-225 bar (3190-3260 psi).

Injection nozzles with incorrect opening pressure should be readjusted by turning the adjusting screw located at the top of the injection nozzle.

2. LEAKAGE TEST

With the valves in the following positions, depress the pump lever until the pressure is 10 to 20 bar (150 to 250 psi) below the specified opening pressure.

ON/OFF Valve	— Closed
Pump Isolator Valve	— Open
Gauge Protector Valve	— Open

If no drops fall from the nozzle spray tip within ten (10) seconds, the nozzle is good.

If a drop falls from the nozzle spray tip within ten (10) seconds, the injection nozzle leaks and should be cleaned and retested. If leakage still exists, the nozzle spray tip may need replacement.

NOTE: Take action to collect fuel that may leak from leak-off connection at the top of the injection nozzle. Otherwise this fuel may dribble down the side and give a false indication of a leaky nozzle.

3. SPRAY PATTERN TEST

With the valves in the following positions, operate the pump lever and note the spray pattern.

ON/OFF Valve	— Closed
Pump Isolator Valve	— Open
Gauge Protector Valve	— Closed

Ensure that all four (4) holes are open. Be aware that the four (4) spray holes are drilled at different angles in the nozzle spray tip. When testing the injection nozzle in a vertical position, some of these holes may be difficult to see.

The spray pattern should have divided spray with coarse atomization at low lever speeds (low = 1/4 lever travel per second). Uniform and well-atomized spray with increased lever travel and speed (fast lever speed is one full stroke per second).

4. CHATTER TEST

The chatter test indicates the ability of the needle valve in the nozzle spray tip to move freely and properly atomize the fuel.

With the valves in the following position, follow the procedures below.

- ON/OFF Valve — Closed
- Pump Isolator Valve — Open
- Gauge Protector Valve — Closed

Used fuel injection nozzles should not be evaluated for chatter at lower lever speeds. A used nozzle can generally be used if it passes the leakage test, chatters audibly at high lever speeds, and uniformly atomizes the fuel.

New fuel injection nozzles should have good audible chatter at all lever speeds. Lowest lever speed is 1/4 travel per second and a fast lever speed is one (1) full travel per second.

7.3 Lube Oil Pressure

With engine warmed up:

- at $n = 650$ rpm at least 0.8 . . . 1 bar (12-14 psi)
- at $n = 3000$ rpm 4 . . . 5 bar (58-72 psi)

Engines not incorporating oil pressure gauges are to be checked prior to delivery.

Check following points if oil pressure is inadequate:

- Oil level
- Oil grade SAE value (see technical data)
- Outdoor temperature (see technical data)
- Condition of relief valve assembly.
- Is pressure gauge in good working order?
- Is oil pump working satisfactorily?
- Checking bearing play on crankshaft and camshaft.
- Are oil drillings choked?
- Are plugs in oil drillings leaking?

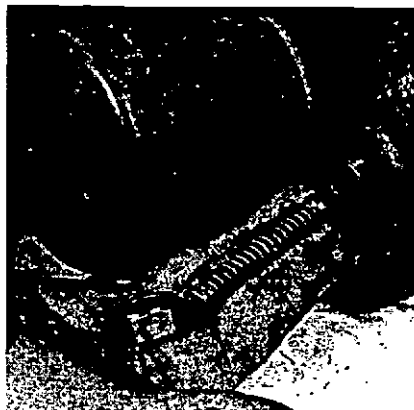
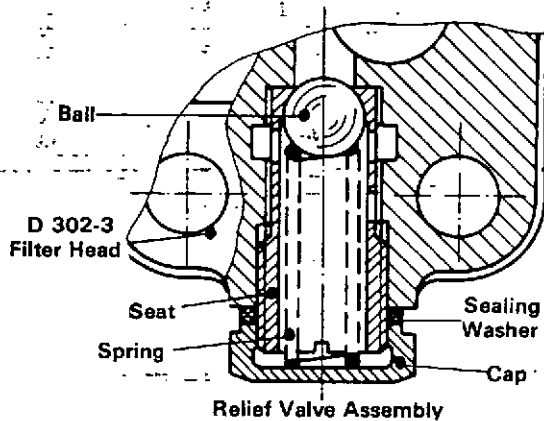

D 302-1 Relief Valve

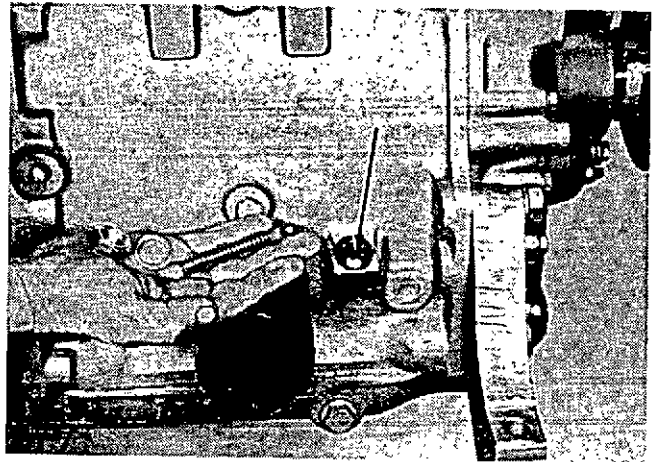

D 302-2 Relief Valve

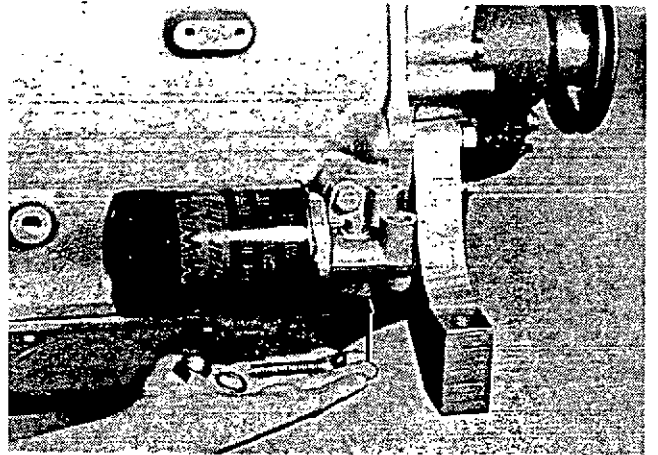

D 302-3 Relief Valve

7.4 Lube Oil Consumption at full load.

Number of Cylinders	1	2	3
per hour approx.	20	40	60cm ³
1 litre lube oil is then consumed in approx.	50	25	16 hours

Lube oil consumption is not guaranteed and depends considerably on:

- engine service (condition of pistons, piston rings and cylinders)
- lube oil quality
- service temperature
- load
- condition of shaft seals

and can thus deviate from the above values.

7.5 Valve Timing

With timing gears correctly set, valve timing is as follows (measured in degrees of crank angle at 1 mm valve clearance).

	opens	closes
Inlet	0° ahead of TDC	30° after BDC
Exhaust	30° ahead of BDC safe tolerance $\pm 3^\circ$	0° after TDC

In conclusion, reset valve clearance to 0.2 mm (.008).

7.6 Valve Sealing

When closed, inlet and exhaust valves are not to allow any diesel fuel (or only max. 2-3 drops per minute) to escape to the intake or exhaust ports.

Regrind leaky valves with reference to refurbishing grades section.

7.7 Fuel Consumption

See technical data section.

Check following items if fuel consumption is excessive:

- Injection nozzle
- Injection pump timing
- Start of delivery
- Injection pump
- Governor adjustment
- Lead wire check
- Compression pressure
- Piston ring condition
- Piston play

ENGINE WON'T START

WON'T TURN OVER

Check electrical connections

Check condition of batteries

Have starter checked

Engine seizure

LOW CRANKING SPEED

Improper lubricating oil viscosity

Check condition of batteries

Check electrical connections at starter and batteries

Have starter checked

WILL TURN OVER

Dense white smoke at exhaust pipe

Version I and II governor activate "start-fuel" button on injection pump

Check for plugged air cleaner or restriction in ducting

Check compression release adjustment (if equipped)

Check governor "start-fuel" adjustment

Check exhaust restriction

Check for faulty injection nozzles

Check compression pressures

Have injection pump checked

Very little or no white smoke at exhaust pipe

Check position of throttle lever

Check fuel and fuel supply

Prime fuel system

Replace fuel filters and supply pump screen

Check fuel piping for kinks and leaks

Check governor "start-fuel" adjustment

Check exhaust restriction

Have fuel supply pump checked

Have injection pump checked

ABNORMAL ENGINE OPERATION

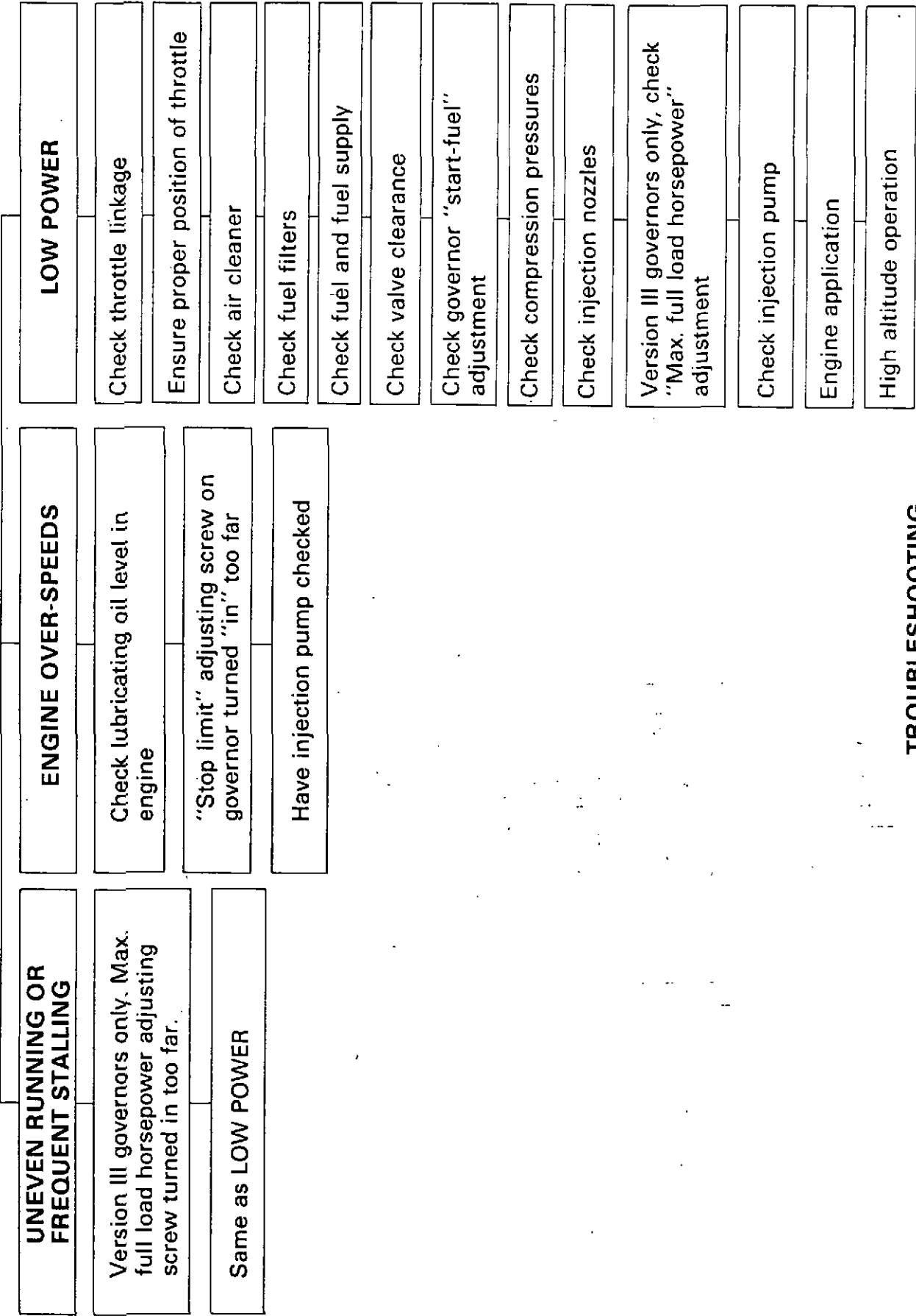

TROUBLESHOOTING

EXHAUST SMOKE

BLACK SMOKE

WHITE SMOKE

BLUE SMOKE

Check for plugged air cleaner or restriction in ducting

See "Engine Won't Start"

See "High Oil Consumption"

Check for exhaust restriction

Check for poor fuel

Check for faulty injection nozzles

Check injection pump timing

Check compression pressure

Version III governors only, check "Max. full load horsepower" adjustment

Have injection pump checked

LUBRICATION SYSTEM

- HIGH OIL CONSUMPTION**
 - Improper oil level (verify dipstick calibration)
 - Use of improper lubricating oil
 - Check for external leaks (seals, gaskets, oil lines, etc.)
 - Check crankcase breather
 - Check installation angle
 - Check compression pressure for condition of rings
 - Check proper positioning of oil control ring on piston

- LOW OR ERRATIC OIL PRESSURE**
 - Improper oil level (verify dipstick calibration)
 - Use of improper lubricating oil
 - Check for defective gauge or sending unit
 - Clean or replace oil pressure relief valve
 - D 302-3 only: if oil pressure is low only at low idle rpm, clean or replace piston cooling nozzle safety valve.
 - Check temperature of lubricating oil
 - Check for leak on suction side of lube oil pump
 - Worn engine parts (e.g., rod and main bearings, cam bearings, etc.)

- HIGH LUBE OIL TEMPERATURE**
 - Defective oil cooler (D 302-3 only)
 - Engine overloaded

TROUBLESHOOTING

COOLING AIR SYSTEM
ABOVE NORMAL
Plugged cooling air inlet screen(s)
Plugged cooling fins
Ducted systems only: 1. High cooling air inlet restriction 2. High cooling air outlet back pressure
D 302-1: plugged cooling fins on flywheel
D 302-2 and D 302-3: slipping "V" belt
Cooling air shroud mis-installed or missing
Defective gauge or sending unit

8.0 MAINTENANCE SCHEDULE

8.1 Refer also to Operating and Maintenance Instructions Manual for detailed instructions.

Non-recurring maintenance operations after	Operating hours	
	30	125
Re-tighten screw connections and cylinder head nuts	30	
Check and tighten V-belt	30	125
Check valve clearance	30	125
Change engine oil and replace lubricating oil filter	30	125

Maintenance operations to be repeated after every	Operating hours		
	250	500	1000
Cleaning air filter 1)	X		
Clean cooling fins, fan and oil cooler 1)	X		
Check and tighten V-belt	X		
Check valve clearance		X	
Change engine oil and replace lubricating oil filter 2)	X		
Replace fuel filter			X

- 1) Earlier if engine is operated under extremely dusty conditions.
Clean oil-wetted air filters not later than after 100 operating hours.
- 2) Or every six months, whichever occurs first.

Maintenance operations for stand-by and emergency operation

monthly	Test run under load.
after 6 months	If 500 operating hours are not reached after the end of 6 months, the maintenance operations prescribed for that interval must be carried out.
after 12 months	If 1000 operating hours are not reached after the end of 12 months, the maintenance operations prescribed for that interval must be carried out.

If the engine is to be taken out of operation for several weeks (during winter, for example), the engine must be preserved (see Operating and Maintenance Manual).

8.2 OVERHAULS

The operational reliability of the engine is reduced after a certain period due to wear and corrosion. In order to avoid engine failures, we recommend carrying out the overhauls listed in the following table. The first operations will be due after 2000 operating hours or after two years, whichever is earlier. The procedures are described in the shop manual which can be supplied by our spare parts department.

Checking injection nozzles	2000
Checking compression	2000
Checking cylinder heads	5000
Checking finned cylinders	5000
Checking connecting rod and main bearings	10000
Checking pistons	10000
Checking crankshaft	10000
Checking camshaft	10000
Checking timing gears	10000
Checking governor	10000
Overhauling injection pump	10000
Replacing lube oil pump	10000
Replacing crankshaft seal	10000
Replacing grooved ball bearing in timing gear cover	10000
Replacing grooved ball bearing in cooling air fan	10000

Skill and expertise are required to carry out the maintenance work (service and overhaul). If no qualified staff is available, our after-sales department will be glad to give any information on different types of service contracts.

Metric Conversion Chart

TO CONVERT	MULTIPLY BY	TO OBTAIN
BAR (kp/cm ²)	14.5	POUNDS PER SQ. IN. (PSI)
CENTIGRADE (°C)	1.8 THEN ADD 32	FAHRENHEIT (°F)
GRAMS (gr)	.03527	OUNCES (oz)
INCHES (in)	25.4	MILLIMETERS (mm)
KILOGRAMS (kg)	2.2046	POUNDS (lb)
KILOMETER (km)	.6214	MILES (STATUTE)
KILOWATTS (kw)	1.341	HORSE POWER (HP)
LITER (dm ³)	61.02	CUBIC INCH (C.I.)
LITER (dm ³)	1.057	QUART (QT.)
LITER (dm ³)	.2642	GALLONS (U.S.)
METER (m)	3.281	FEET (FT.)
METERS-KILOGRAM (mkp) OR (mkg)	7.233	POUND-FEET (lb-ft)
MILLIMETERS (mm)	.03937	INCHES (in)
NEWTON METER (Nm)	.7376	POUND-FEET (lb-ft)

The multiplying SI prefixes

The multiples and sub-multiples of the basic and derived units are not unrelated to the units as is usual in the UK and US systems (e.g., yard, foot, inch and pound, grain, ounce). They are formed by means of prefixes which are the same, no matter to which unit they are applied.

Prefix	Symbol	Factor by which the unit is multiplied
tera	T	10 ¹² = 1000000000000
giga	G	10 ⁹ = 1000000000
mega	M	10 ⁶ = 1000000
kilo	k	10 ³ = 1000
hecto	h	10 ² = 100
deca	da	10 ¹ = 10
deci	d	10 ⁻¹ = 0.1
centi	c	10 ⁻² = 0.01
milli	m	10 ⁻³ = 0.001
micro	μ	10 ⁻⁶ = 0.000001
nano	n	10 ⁻⁹ = 0.000000001
pico	p	10 ⁻¹² = 0.000000000001
femto	f	10 ⁻¹⁵ = 0.000000000000001
atto	a	10 ⁻¹⁸ = 0.000000000000000001

The Metric System of Weights and Measures

Linear Measure

10 millimetres (mm)	= 1 centimetre (cm)
10 centimetres	= 1 decimetre (dm)
10 decimetres	= 1 metre (m)
10 metres	= decametres (dam)
10 decametres	= hectometre (hm)
10 hectometres	= kilometre (km)

Square Measure

100 square millimetres (mm ²)	= 1 square centimetre (cm ²)
100 square centimetres	= 1 square decimetre (dm ²)
100 square decimetres	= 1 square metre (m ²)
100 square metres	= 1 are (1 square decametre)
100 ares	= hectare (ha) (1 square hectometre)
100 hectares	= square kilometre (km ²)

Cubic Measure

1000 cubic millimetres (mm ³)	= 1 cubic centimetre (cm ³)
1000 cubic centimetres	= cubic decimetre (dm ³)
1000 cubic decimetres	= cubic metre (m ³)