

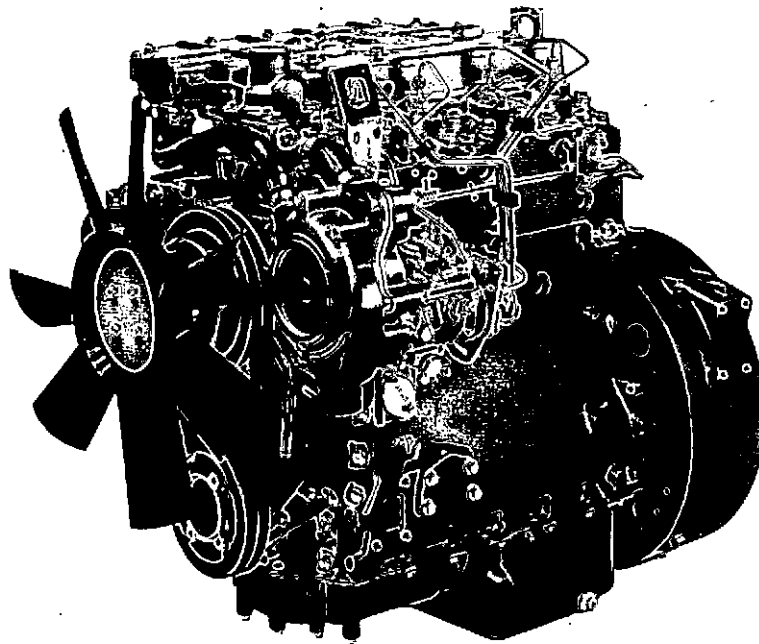

# User's Handbook



**New 1000 Series**  
Models AJ to AS and YG to YK  
TPD 1349E

---

# **Perkins New 1000 Series**

Models AJ to AS and YG to YK

## **USER'S HANDBOOK**

**4 and 6 cylinder diesel engines for industrial, and  
agricultural applications**

Publication TPD 1349E Issue 4

© *Proprietary information of Perkins Engines Company Limited, all rights reserved.*

The information is correct at the time of print.

Published in December 1999 by Technical Publications,

Perkins Engines Company Limited, Peterborough PE1 5NA, England

---

This publication is written in  
Perkins Approved Clear English

**PACE**

---

# Contents

*Continued*

## 1 General information

Introduction .....	5
How to care for your engine .....	6
Engine identification .....	7
Perkins companies .....	8
General safety precautions .....	9

## 2 Engine views

Introduction .....	11
Location of engine parts .....	11

## 3 Operation instructions

How to start the engine .....	13
How to stop the engine .....	15
Adjustment of the engine speed range .....	15
Running-in .....	15
Turbocharged engines .....	15
Altitude .....	15
Angle of tilt .....	15

## 4 Preventive maintenance

Preventive maintenance periods .....	17
Preventive maintenance schedules .....	17
Preventive maintenance schedules .....	18
How to fill the coolant circuit .....	20
How to drain the cooling system .....	21
How to check the specific gravity of the coolant .....	23
How to check the drive belt(s) .....	24
How to clean the gauze strainer of the fuel lift pump .....	25
Fuel pre-filter .....	25
How to renew the fuel filter .....	26

Atomiser maintenance .....	29
How to remove and to fit an atomiser .....	30
How to eliminate air from the fuel system .....	32
How to renew the lubricating oil of the engine .....	34
How to renew the canister of the lubricating oil filter .....	35
How to maintain the engine open breather system .....	36
How to maintain the closed engine breather system .....	37
Air filter .....	38
Restriction indicator .....	38
How to check the valve tip clearances .....	39

## 5 Engine fluids

Fuel specification .....	41
Lubricating oil specification .....	42
Coolant specification .....	43

## 6 Fault diagnosis

Problems and possible causes .....	46
List of possible causes .....	47

## 7 Engine preservation

Introduction .....	49
--------------------	----

## 8 Parts and service

Introduction .....	51
Service literature .....	51
Training .....	51
POWERPART recommended consumable products .....	52

## 9 General data

Engine .....	53
--------------	----

# 1

## General information

### Introduction

The Perkins New 1000 Series engines for industrial and agricultural applications are the latest developments from Perkins Engines Company Limited, a world leader in the design and manufacture of high performance diesel engines.

The engine conforms with USA (EPA/CARB) stage 1 and EEC stage 1 emissions legislation for agricultural and industrial applications.

More than sixty years of diesel production experience, together with the latest technology, have been applied to the manufacture of your engine to give you reliable and economic power.

To ensure that you use the relevant information for your specific engine type, refer to "Engine identification" on page 7.

Danger is indicated in the text by two methods:

**Warning!** This indicates that there is a possible danger to the person.

**Caution:** This indicates that there is a possible danger to the engine.

**Note:** Is used where the information is important, but there is not a danger.

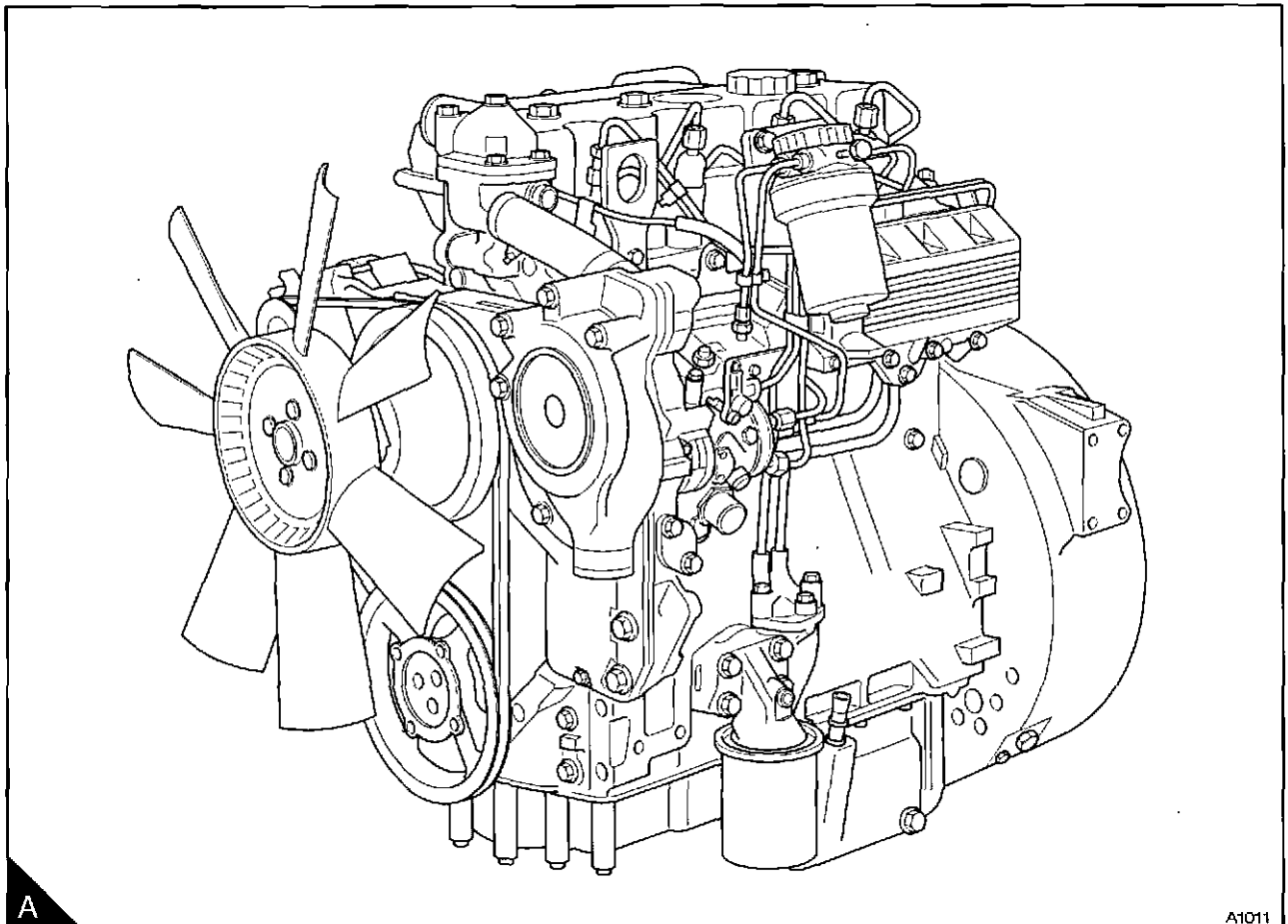

A

A1011

---

## How to care for your engine

**Warning!** Read the "Safety precautions" and remember them. They are given for your protection and must be applied at all times.

**Caution:** Do not clean an engine while it runs. If cold cleaning fluids are applied to a hot engine, certain components on the engine may be damaged.

This handbook has been written to assist you to maintain and operate your engine correctly.

To obtain the best performance and the longest life from your engine, you must ensure that the maintenance operations are done at the intervals indicated in "Preventive maintenance". If the engine works in a very dusty environment or other adverse conditions, certain maintenance intervals will have to be reduced. Renew the filter canisters and lubricating oil regularly in order to ensure that the inside of your engine remains clean.

Ensure that all adjustments and repairs are done by personnel who have had the correct training. Perkins distributors have this type of personnel available. You can also obtain parts and service from your Perkins distributor. If you do not know the address of your nearest distributor, enquire at one of the Perkins companies listed on page 8.

The "left side" and "right side" of the engine are as seen from the flywheel end.

## Engine identification

The New 1000 Series consists of a range of both four and six cylinder engines. Each range has three basic engine types, naturally aspirated, turbocharged and turbocharged with an intercooler.

There are different model variations within each range. Identification of the various models is by a system of numbers and letters, for example:

### 1006-60TW

1006	6 cylinder engine
-60	6 litre engine
T	Turbocharged
TW	Turbocharged, but with an air to water intercooler to cool the induction air between the turbocharger and the cylinders.

In this handbook, the different engine types are indicated by their code letters, which are the first two letters of the engine number as indicated below:

Code Letters	Engine type
AJ	Four cylinder, naturally aspirated
AK	Four cylinder, turbocharged
AM	Four cylinder, turbocharged and intercooled
AP	Four cylinder, naturally aspirated, belt driven coolant pump
AQ	Four cylinder, turbocharged, belt driven coolant pump
AR	Four cylinder, naturally aspirated, 103 mm cylinder bores
AS	Four cylinder, naturally aspirated, belt driven coolant pump, 103 mm cylinder bores
YG	Six cylinder, naturally aspirated
YH	Six cylinder, turbocharged
YJ	Six cylinder, turbocharged and air-to-air intercooled
YK	Six cylinder, turbocharged and air-to-water intercooled.

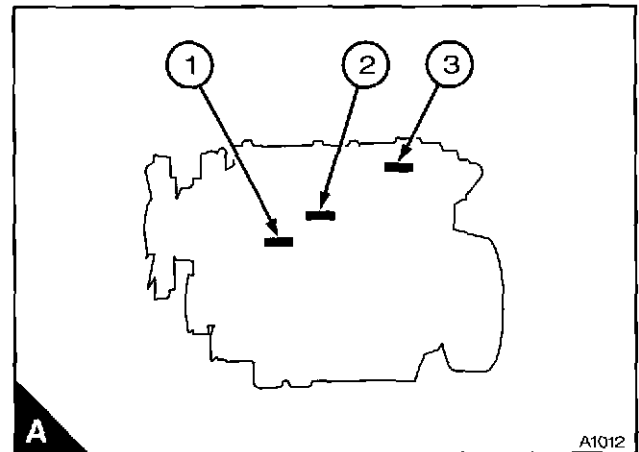

The correct identification of the engine is by the full engine number.

The engine number is stamped on a label (A2) which is fastened to the left side of the cylinder block. An example of the engine number is:

**AK80920\*U510256F\***

If you need parts, service or information for your engine, you must give the complete engine number to your Perkins distributor. If there is a number in the area of the label marked TPL N<sup>o</sup>, then this number must also be given to your Perkins distributor.

Other identification labels fitted to the engine include:

An emissions legislation label (A3) fitted to the side of the cylinder block.

A label (A1) with the fuel injection pump part numbers.

**Perkins companies****Australia**

Perkins Engines Australia Pty. Ltd,  
Suite 4, 13A Main Street,  
Morningside 3931, Victoria, Australia.  
Telephone: 0061 (0) 597 51877  
Telex: Perkoil AA30816  
Fax: 0061 (0) 0597 1305

**France**

Perkins France S.A.S.,  
"Parc des reflets"  
165 Avenue Du Bois de la Pie  
95700 Roissy Charles de Gaulle, France.  
Telephone: 0033 (01) 49 90 7171  
Fax: 0033 (01) 49 90 7190

**Germany**

Perkins Motoren GmbH,  
Saalaeckerstrasse 4,  
63801 Kleinostheim,  
Germany.  
Telephone: 0049 6027 5010  
Fax: 0049 6027 501124

**Italy**

Motori Perkins S.p.A.,  
Via Socrate 8,  
22070 Casnate con Bernate (Como), Italy.  
Telephone: 0039 (0) 31 564633 / 564625  
Telex: 380658 Perkit I  
Fax: 0039 (0-) 31 396001

**Japan**

Perkins Engines, Inc.,  
Address Building, 8th Floor,  
2-2-19 Akasaka, Minato-ku,  
Tokyo 107-0052, Japan.  
Telephone: 0081 (0) 3 3560 3878  
Fax: 0081 (0) 3 3560 3877

**Singapore**

Perkins Engines (Far East) pte Ltd  
Tuas Avenue 13  
Singapore 638999  
Telephone: (65) 861 1318  
Fax: (65) 861 6252

**United Kingdom**

Perkins Engines Company Ltd,  
Eastfield, Peterborough PE1 5NA,  
England.  
Telephone: 0044 (0) 1733 58 3000  
Telex: 32501 Perken G  
Fax: 0044 (0) 1733 582240

**United States of America**

Perkins International - North America,  
26200 Town Center Drive,  
Suite 280,  
Novi, Michigan 48375  
USA  
Telephone: 001 248 374 3100  
Fax: 001 248 374 3110

Perkins Engines Latin America Inc,  
Suite 620,  
999, Ponce de Leon Boulevard,  
Coral Gables,  
Florida 33134, U.S.A.  
Telephone: 001 305 442 7413  
Telex: 32501 Perken G  
Fax: 001 305 442 7419

**In addition to the above companies, there are Perkins distributors in most countries. Perkins Engines Company Ltd., Peterborough or one of the above companies can provide details.**

## General safety precautions

**These safety precautions are important.** You must refer also to the local regulations in the country of use. Some items only refer to specific applications.

- Only use these engines in the type of application for which they have been designed.
- Do not change the specification of the engine.
- Do not smoke when you put fuel in the tank.
- Clean away fuel which has been spilt. Material which has been contaminated by fuel must be moved to a safe place.
- Do not put fuel in the tank while the engine runs (unless it is absolutely necessary).
- Do not clean, add lubricating oil, or adjust the engine while it runs (unless you have had the correct training; even then extreme care must be used to prevent injury).
- Do not make adjustments that you do not understand.
- Ensure that the engine does not run in a location where it can cause a concentration of toxic emissions.
- Other persons must be kept at a safe distance while the engine or auxiliary equipment is in operation.
- Do not permit loose clothing or long hair near moving parts.
- Keep away from moving parts during engine operation. **Warning!** *Some moving parts cannot be seen clearly while the engine runs.*
- Do not operate the engine if a safety guard has been removed.
- Do not remove the filler cap or any component of the cooling system while the engine is hot and while the coolant is under pressure, because dangerous hot coolant can be discharged.
- Do not allow sparks or fire near the batteries (especially when the batteries are on charge) because the gases from the electrolyte are highly flammable. The battery fluid is dangerous to the skin and especially to the eyes.
- Disconnect the battery terminals before a repair is made to the electrical system.
- Only one person must control the engine.
- Ensure that the engine is operated only from the control panel or from the operators position.
- If your skin comes into contact with high-pressure fuel, obtain medical assistance immediately.
- Diesel fuel and lubricating oil (especially used lubricating oil) can damage the skin of certain persons. *Protect your hands with gloves or a special solution to protect the skin.*
- Do not wear clothing which is contaminated by lubricating oil. Do not put material which is contaminated with oil into the pockets of clothing.
- Discard used lubricating oil in accordance with local regulations to prevent contamination.
- Ensure that the control lever of the transmission drive is in the "out-of-drive" position before the engine is started.
- Use extreme care if emergency repairs must be made in adverse conditions.
- The combustible material of some components of the engine (for example certain seals) can become extremely dangerous if it is burned. Never allow this burnt material to come into contact with the skin or with the eyes.
- Always use a safety cage to protect the operator when a component is to be pressure tested in a container of water. Fit safety wires to secure the plugs which seal the hose connections of a component which is to be pressure tested.
- Do not allow compressed air to contact your skin. If compressed air enters your skin, obtain medical help immediately.
- Turbochargers operate at high speed and at high temperatures. Keep fingers, tools and debris away from the inlet and outlet ports of the turbocharger and prevent contact with hot surfaces.
- Do not clean an engine while it runs. If cold cleaning fluids are applied to a hot engine, certain components on the engine may be damaged.
- Fit only genuine Perkins parts.

# 2

## Engine views

### Introduction

Perkins engines are built for specific applications and the views which follow do not necessarily match your engines specification.

### Location of engine parts

#### Front and left side of the AK engine (A)

- |                                      |                                      |
|--------------------------------------|--------------------------------------|
| 1 Filler cap for the lubricating oil | 8 Drain plug for the lubricating oil |
| 2 Atomiser                           | 9 Crankshaft pulley                  |
| 3 Fuel filter                        | 10 Drive belt                        |
| 4 Lubricating oil cooler             | 11 Fan                               |
| 5 Fuel injection pump                | 12 Coolant pump                      |
| 6 Lubricating oil dipstick           | 13 Front lift bracket                |
| 7 Lubricating oil filter             | 14 Thermostat housing                |

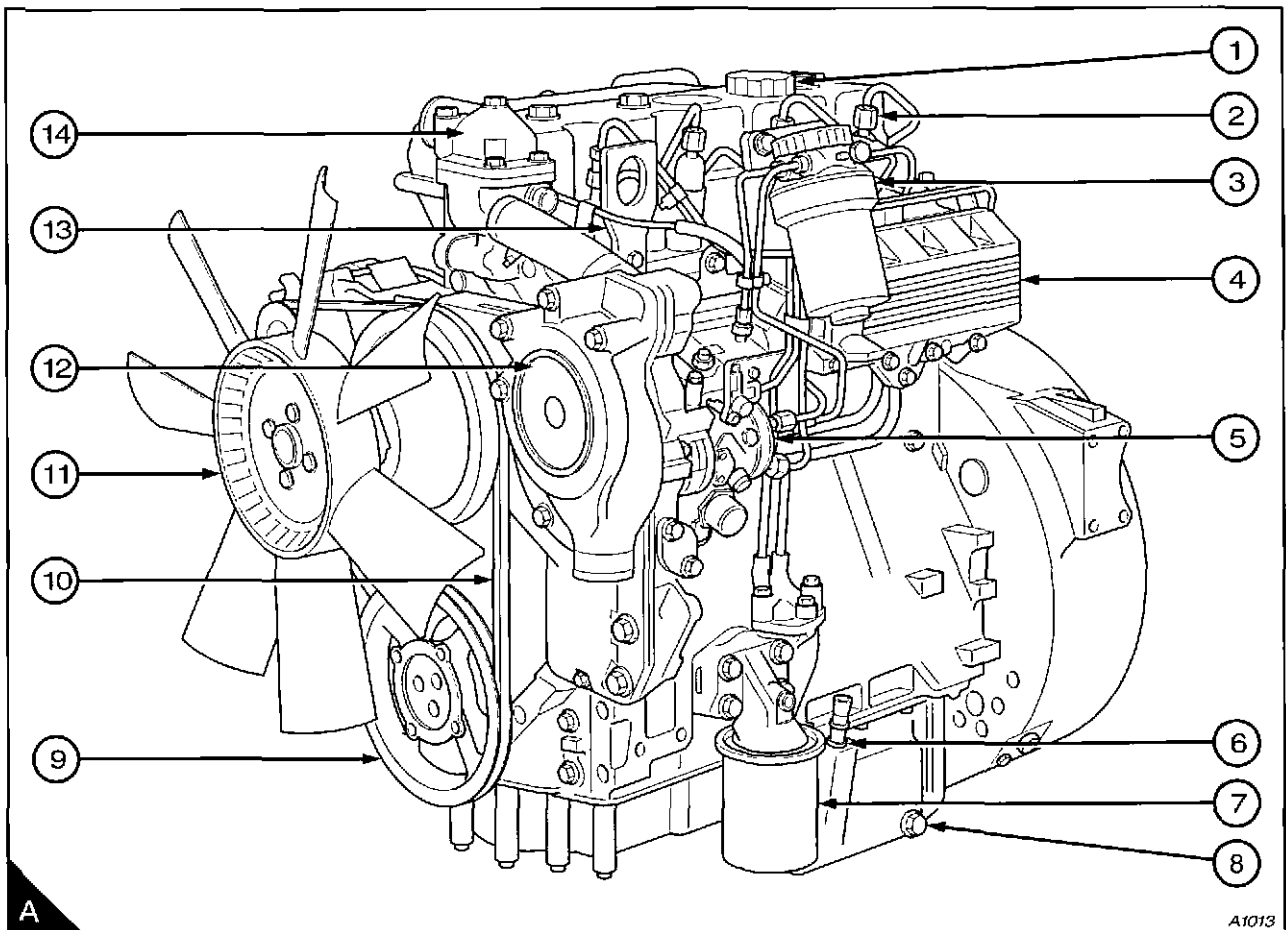

A1013

# 2

## Rear and right side of the AK engine (A)

- |                       |                         |
|-----------------------|-------------------------|
| 15 Coolant outlet     | 21 Lubricating oil sump |
| 16 Induction manifold | 22 Flywheel housing     |
| 17 Exhaust manifold   | 23 Flywheel             |
| 18 Alternator         | 24 Fuel lift pump       |
| 19 Turbocharger       | 25 Cold starting aid    |
| 20 Starter motor      | 26 Rear lift bracket    |

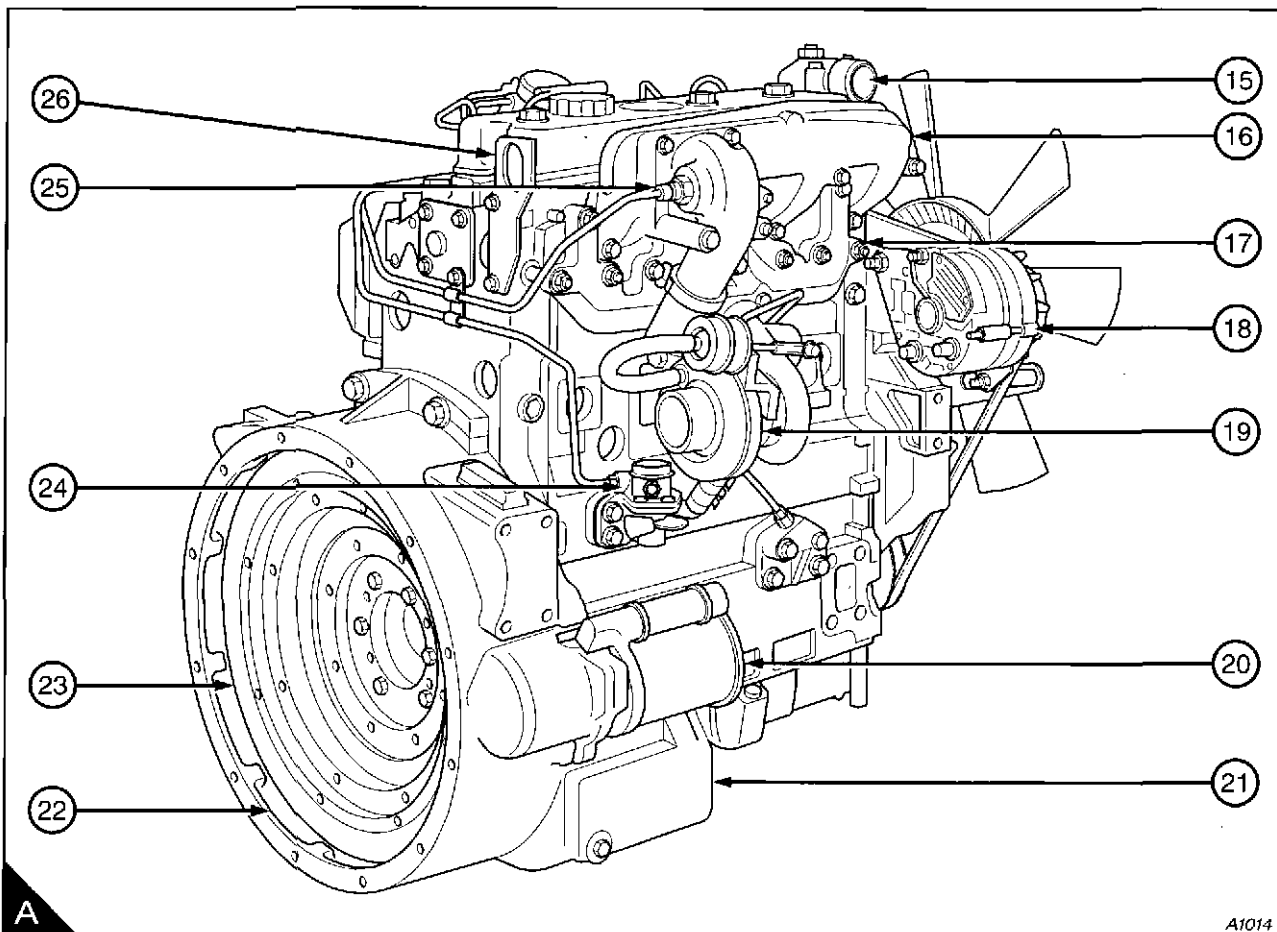

A1014

# 3

## Operation instructions

### How to start the engine

#### **Cautions:**

- Do not operate the engine at high speeds without a load.
- If the engine has not run for several weeks, see "Caution" on page 50.

Several factors affect engine start, for example:

- The power of the batteries
- The performance of the starter motor
- The viscosity of the lubricating oil
- The installation of a cold start system

The engine is fitted with an automatic cold starting device for normal conditions of operation. Diesel engines need an extra cold starting aid if they are to start in very cold conditions. Normally, your vehicle or your machine will be fitted with the correct equipment for your region of operation.

Perkins engines can be equipped with various cold starting systems. The New 1000 Series is fitted with either a fuelled starting aid or port heaters as standard equipment:

#### **Fuelled starting aid**

An electrically operated device which ignites a specific amount of diesel fuel in the induction manifold in order to heat the induction air.

#### **Port heaters**

These electrical devices are fitted in the induction manifold and heat the induction air. They are operated automatically when the starter motor is engaged. When these devices are fitted, the start procedure for a cold engine is the same as that given for a cold engine start without starting aids.

If the engine is fitted with a cold starting device which is not fitted as standard equipment by Perkins engines, refer to the application Users Handbook or the instructions given by the manufacturer of the cold starting device, before starting the engine.

Examples of cold starting devices which are not fitted as standard equipment by Perkins engines are listed below:

#### **Start Pilot**

**Caution:** Start Pilot equipment must not be used with heater type starting aids such as the fuelled starting aid.

A hand pump is used to inject a cold start fluid into the induction manifold through an atomiser. The cold start fluid ignites at a lower temperature than diesel fuel. The cold start fluid is contained in a separate reservoir. Certain models use a push button to actuate a solenoid which releases the cold start fluid from an aerosol container.

#### **KBi**

**Caution:** KBi equipment must not be used with heater type cold starting aids such as the fuelled starting aid.

This system uses an aerosol container filled with a cold start fluid. The fluid is released by a solenoid, which is operated by a push button. The cold start fluid is sprayed into the induction manifold through a nozzle. The cold start fluid ignites at a lower temperature than diesel fuel.

# 3

## How to start a warm engine

- 1 If the engine is equipped with a manual stop control, ensure that it is in the "run" position.
- 2 Adjust the engine speed control to the quarter open position.
- 3 Turn the start key to the "HS" or "S" position (A) or (B) to engage the starter motor.
- 4 Allow the start key to return to the "R" position, as soon as the engine starts.

Always ensure that the engine and starter motor are stationary before the starter motor is engaged again.

## How to start a cold engine without starting aids

- 1 If the engine is equipped with a manual stop control, ensure that it is in the "run" position.
- 2 Adjust the engine speed control to the maximum speed position.
- 3 Turn the start key to the "S" position (B) to engage the starter motor. Allow the key to return to the "R" position, when the engine starts. Then adjust the engine speed control to get an even idle speed.
- 4 If the engine does not start in 30 seconds, allow the start key to the "R" position for another 30 seconds. Then engage the starter motor again for a maximum period of 30 seconds.

## How to start a cold engine with the fuelled starting aid

**Caution:** Ether type fuels must not be used at the same time as a fuelled starting aid.

- 1 If the engine is equipped with a manual stop control, ensure that it is in the "run" position.
- 2 Turn the start key to the "H" position (A) and keep it there for 15 seconds.
- 3 Adjust the engine speed control to the maximum speed position.
- 4 Turn the start key to the "HS" position in order to engage the starter motor. Allow the start key to return to the "R" position, when the engine starts. Then adjust the engine speed control to give an even idle speed.
- 5 If the engine does not start in 15 seconds, turn the start key to the "H" position and hold it there for 10 seconds. Then engage the starter motor again.

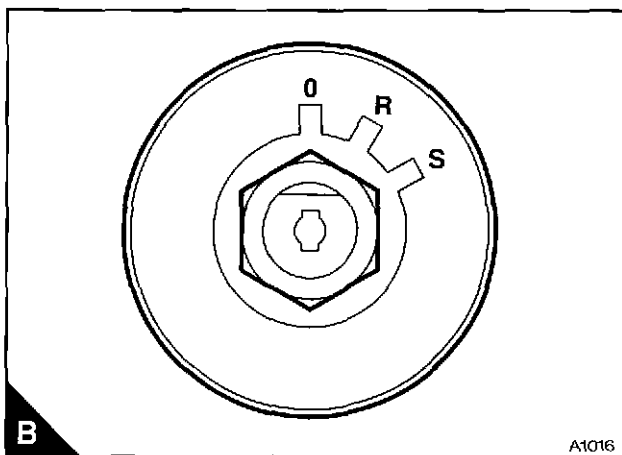
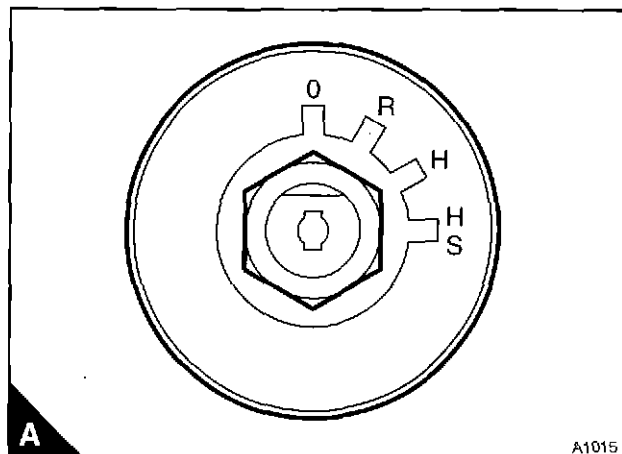

## How to stop the engine

**Caution:** *It is recommended that a turbocharged engine is run at approximately 1000 rev/min at a reduced load for 2-3 minutes before it is shut down. This will allow the turbocharger to cool.*

According to the equipment fitted, either turn the engine start key to the "O" position (A or B page 14) or operate the manual stop control. If a manual stop control is used, ensure that the control returns to the "run" position after the engine has stopped. Also ensure that the engine start key is turned to the "O" position.

## Adjustment of the engine speed range

The engine conforms with USA (EPA/CARB) stage 1 and EEC stage 1 emissions legislation for agricultural and industrial applications.

The engine speed settings should not be changed by the engine operator, because this can cause the exhaust emissions to become excessive and may also damage the engine or transmission. Specialist equipment, which is available at your Perkins Distributor, is needed to adjust the fuel injection pump. The warranty of the engine may be affected if the seals on the fuel injection pump are broken during the warranty period by a person who is not approved by Perkins.

## Running-in

### Cautions:

- *Do not operate the engine at high speeds without a load.*
- *Do not overload the engine.*

A gradual running-in of a new engine or an exchange engine is not necessary. Prolonged operation at light loads during the early life of the engine can cause lubricating oil to enter the exhaust system. Maximum load can be applied to a new engine as soon as the engine is put into service and the coolant temperature has reached a minimum of 60°C (140°F).

The engine will benefit if the load is applied as soon as possible after the engine is put into service.

## Turbocharged engines

Because of the power characteristics of the turbocharged engines it is necessary to maintain a high engine speed when you climb a gradient. To ensure that the engine is not overloaded at low engine speeds engage a lower gear.

## Altitude

If a naturally aspirated engine is to be operated permanently at an altitude above 600 m (2,000 ft), the fuel consumption and exhaust emissions may become excessive. For further information about the operation of the engine above 600 m (2,000 ft), refer to your nearest Perkins Distributor.

## Angle of tilt

If a closed circuit engine breather valve is fitted to the engine, see the warning below.

**Warning!** *Do not operate the engine at an angle of tilt greater than the limit approved for the engine. If there is doubt, contact the Perkins Service Department. If the approved angle is exceeded, an excess of lubricating oil could enter the breather valve. This could cause the engine speed to increase rapidly without control.*

# 4

## Preventive maintenance

### Preventive maintenance periods

These preventive maintenance periods apply to average conditions of operation. Check the periods given by the manufacturer of the equipment in which the engine is installed. If necessary, use shorter periods. When the operation of the engine must conform to the local regulations these periods and procedures may need to be adapted to ensure correct operation of the engine.

It is good preventive maintenance to check for leakage and loose fasteners at each service.

These maintenance periods apply only to engines that are operated with fuel, lubricating oil and coolant which conform to the specifications given in this handbook.

Use the procedures in this section to maintain your engine in accordance with the preventive maintenance schedule on page 18.

### Preventive maintenance schedules

The schedules which follow must be applied at the interval (hours or months) which occur first.

- A First service at 20/40 hours
- B Every day or every 8 hours
- C Every 250 hours or 6 months
- D Every 500 hours or 12 months
- E Atomiser maintenance

A	B	C	D	E	Operation
•	•				Check the amount of coolant in the header tank
	•				Check the engine for leakage of oil and coolant
			•		Check the specific gravity of the coolant <sup>(1)</sup> <sup>(2)</sup>
•		•			Check the tension and condition of the drive belt(s)
			•		Clean the sediment chamber and the strainer of the fuel lift pump
		•			Check for water in the pre-filter bowl (or earlier if your fuel supply is contaminated)
			•		Renew the element(s) of the fuel filter(s)
					Ensure that the idle speed is checked and adjusted, if it is necessary <sup>(2)</sup>
				•	Atomiser maintenance, <sup>(2)</sup> refer to page 29

(1) Check the specific gravity every 12 months and renew the antifreeze every 2 years. If a coolant inhibitor is used instead of antifreeze, it should be renewed every 6 months. If combustion gases are released into the coolant circuit, the coolant must be renewed.

(2) By a person who has had the correct training.

*Continued*

# 4

## Preventive maintenance schedules

The schedules which follow must be applied at the interval (hours or months) which occur first.

- |   |                              |   |                  |
|---|------------------------------|---|------------------|
| A | First service at 20/40 hours | E | Every 1000 hours |
| B | Every day or every 8 hours   | F | Every 2000 hours |
| C | Every 250 hours or 6 months  | G | Every 8000 hours |
| D | Every 500 hours or 12 months |   |                  |

A	B	C	D	E	F	G	Operation
	•						Check the amount of lubricating oil in the sump
	•						Check the lubricating oil pressure at the gauge
			•				Renew the engine lubricating oil. <sup>(2)</sup> Also refer to page 19
			•				Renew the canister(s) of the lubricating oil filter. <sup>(2)</sup> Also refer to page 19
						•	Clean the gauze element of the engine open breather system
						•	Renew the closed breather assembly <sup>(3)</sup>
							Empty the dust bowl of the air filter
•	•						- extremely dusty conditions
		•					- normal conditions
			•				Clean or renew the air filter element, if it has not been indicated earlier
						•	Ensure that the turbocharger impeller and turbocharger compressor casing are cleaned <sup>(1)</sup>
		•					Check all hoses and connections
		•					Clean the compressor air filter
						•	Ensure that the exhauster or compressor is checked <sup>(1)</sup>
•		•					Check all electrical cables and connections <sup>(4)</sup>
•				•			Ensure that the valve tip clearances of the engine are checked and, if necessary, adjusted <sup>(1)</sup>
						•	Ensure that the alternator, the starter motor are checked <sup>(1)</sup>

(1) By a person who has had the correct training.

(2) The oil service interval will change with the amount of sulphur in the fuel (see the table and the fuel specification in section 5). The interval to change the canister of the lubricating oil filter is not affected.

(3) The closed breather assembly must be renewed every 8000 hours or at every complete engine overhaul

(4) **Caution:** Damage to the engine will occur if there is a failure in the electrical circuit for the cold start advance. The engine will run continuously with the timing fully advanced.

<b>Lubricating oil and oil filter canister service interval by application <sup>(1)</sup></b>		
<b>250 Hours</b>	<b>500 Hours</b>	<b>500 Hours</b>
<b>Agricultural</b>	<b>Agricultural</b>	<b>Material handling</b>
Tractors over 120 bhp and all four wheel drives	Tractors under 120 bhp, not four wheel drive	Fork-lift trucks
Logging machinery	Ride-on mowers	Rough terrain fork-lift trucks
Combine harvesters	Woodchippers	Baggage handlers
All other agricultural applications except those listed under 500 hours	<b>Construction</b>	Straddle carriers
<b>Construction</b>	Wheeled shovel loaders	Mobile handling equipment
Road making plant	Telescopic handlers	Stationary material handling equipment
Rock crushing equipment	Road rollers, Backhoe loaders	<b>Vehicle</b>
Bulldozers, Trenchers	Skid steer loaders	Cars, vans and mini cars
Graders, Dumpers	Excavators, Cranes	Buses, Ambulances
Scrapers, Concrete mixers		Fire appliances
Crawler tractors		Refuse collectors
	<b>Industrial</b>	
	Combined heat and power generating sets	
All other construction applications except those listed under 500 hours	Mine personnel carriers	
<b>Generating sets</b>	Mine dumpers	
Base and prime power generating sets	Underground drill equipment	
<b>Industrial</b>	Welding sets	
Locomotives and rail equipment	Sweepers	
Compressors, Loaders	Aircraft towing tractor	
Pumping equipment	Refrigeration equipment	
Mine loaders	<b>Generating sets</b>	
Road sweepers (auxiliary engines)		
All other industrial applications except those listed under 500 hours	Aircraft ground power units	
<b>Vehicle</b>	Stand-by generating sets	
All other vehicle applications except those listed under 500 hours	Lighting towers	

(1) The service interval for the lubricating oil and oil filter canister is normally 500 hours. This may be reduced to 250 hours for **applications which have engines operating at high load conditions**. Refer to your equipment supplier's handbook for the application, or the table above for guidance. If further advice is necessary, refer to your nearest Perkins distributor.

# 4

## How to fill the coolant circuit

**Warning!** Refer to your equipment supplier's handbook for the application to fill the coolant system. If coolant is to be added to the circuit during service, allow the engine to cool before the coolant is added. Remove the filler cap slowly as dangerous coolant could be discharged if the coolant is still hot and the system under pressure.

**Caution:** If coolant is added to the circuit during service, it must consist of the same original mixture as used to fill the system. See "Coolant specification" in section 5 for details of the correct coolant to be used in the circuit.

### For engines fitted with intercoolers:

**Caution:** When the coolant system is filled it is important to eliminate air from the intercooler to prevent an overheated engine.

- 1 Ensure that the top and bottom hose connections are fitted correctly.
- 2 Fit the drain plug on the side of the cylinder block and ensure that the radiator tap is closed, if one is fitted.
- 3 Fill the coolant system with coolant of the correct specification, refer to section 5.
- 4 Open the vent screw (A1 or A2) on the top pipe of the intercooler until coolant free of air flows from the screw. Then tighten the vent screw.
- 5 Continue to slowly fill the coolant system to the correct level in the radiator, refer to the user's handbook for the application.

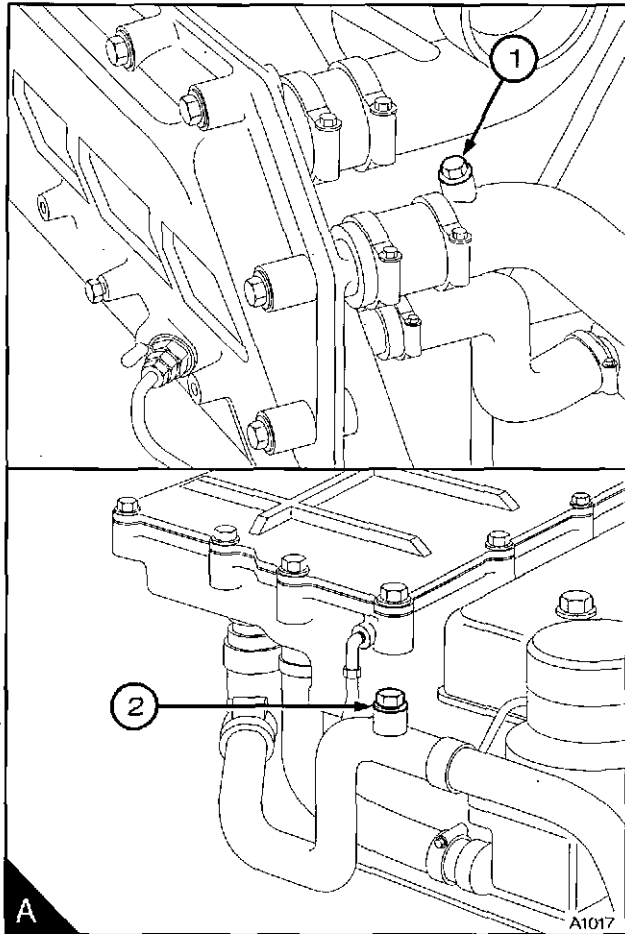

## How to drain the cooling system

**Warning!** Do not drain the coolant while the engine is still hot and the system is under pressure because dangerous hot coolant can be discharged.

1 Ensure that the vehicle or machine is on level ground.

2 Remove the filler cap of the coolant system.

**Caution:** To prevent frost damage, ensure that all of the coolant is removed from the engine. This is important if the system is drained after it has been flushed with water, or if an antifreeze solution too weak to protect the system from frost has been used.

3 For engines fitted with intercoolers: Open the vent screw (A1) for vertical intercoolers or (A2) for horizontal intercoolers. This will ensure that all of the coolant is drained from the intercooler.

4 Remove the drain plug (B or C) from the side of the cylinder block in order to drain the engine. Ensure that the drain hole is not restricted.

5 Open the tap or remove the drain plug at the bottom of the radiator in order to drain the radiator. If the radiator does not have a tap or drain plug, disconnect the hose at the bottom of the radiator.

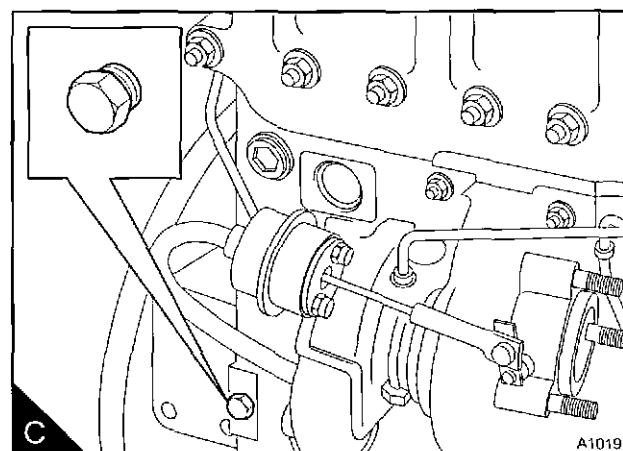
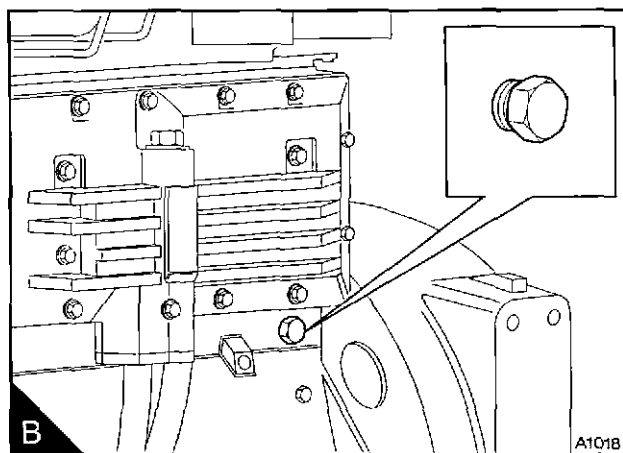
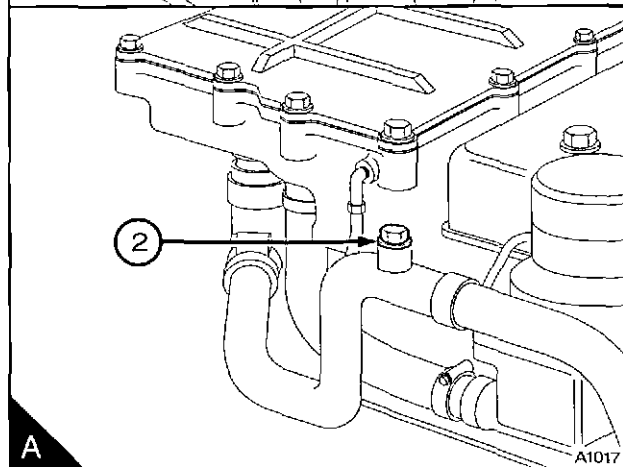
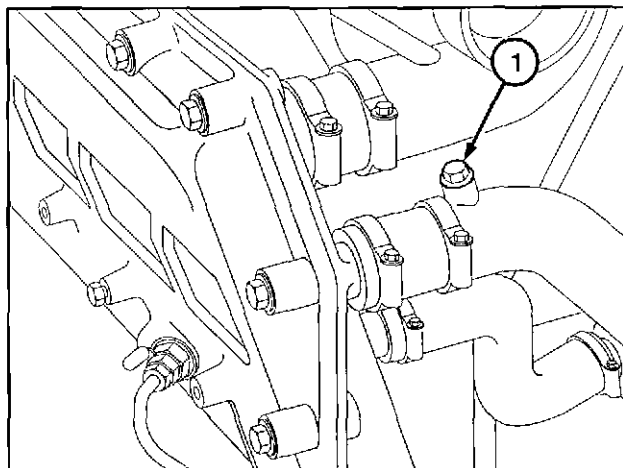

# 4

6 If a lubricating oil cooler (A) is fitted to the filter head instead of the cylinder block, then this must also be drained and flushed. To do this, disconnect the hoses (A1 and A2) at the top of the cooler and flush the oil cooler through the outlet connection (A1) until clean water flows from the inlet (A2).

**Caution:** If the coolant system is to remain empty temporarily after it is flushed with clean water, drain the oil cooler and fill it with 165 ml (1/3 pint) of antifreeze. This will protect the oil cooler against frost if any clean water drains down from the water jacket when the vehicle is moved.

7 Flush the coolant system with clean water.

8 Fit the hoses to the top of the cooler and tighten the clips.

9 Fit the drain plugs and the filler cap. Close the radiator tap or connect the radiator hose.

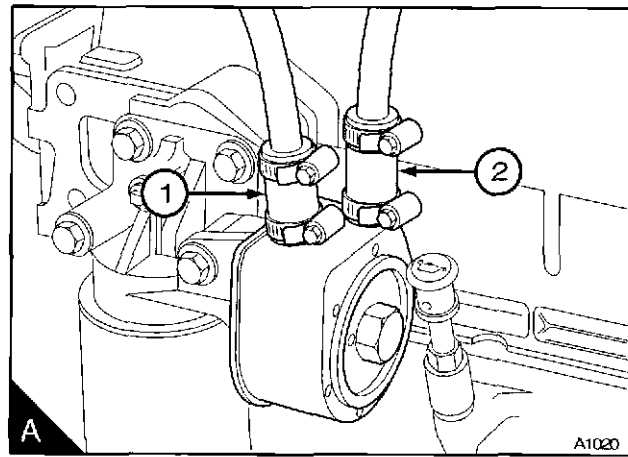

## How to check the specific gravity of the coolant

For mixtures which contain inhibited ethylene glycol:

- 1 Ensure that the machine is on level ground.
- 2 Operate the engine until it is warm enough to open the thermostat. Continue to run the engine until the coolant has circulated the cooling system.
- 3 Stop the engine.
- 4 Allow the engine to cool until the temperature of the coolant is below 60°C (140°F).

**Warning!** Do not drain the coolant while the engine is still hot and the system is under pressure because dangerous hot coolant can be discharged.

- 5 Remove the filler cap of the cooling system.
- 6 Drain some coolant from the cooling system into a suitable container.
- 7 Use a special coolant hydrometer that will check the temperature and the specific gravity of the coolant, follow the manufacturer's instructions.

**Note:** If a special coolant hydrometer is not available, put a hydrometer and a separate thermometer into the antifreeze mixture and check the readings on both instruments. Compare the readings with the chart (A).

- 8 Adjust the strength of the mixture as necessary.

**Note:** If it is necessary to fill or replenish the coolant system in service, mix the coolant to the correct strength before it is added to the coolant system. Perkins POWERPART antifreeze with a concentration of 50% will give protection against frost to a temperature of -35°C (-31°F). It will also give protection against corrosion. This is especially important when there are aluminium components in the coolant circuit.

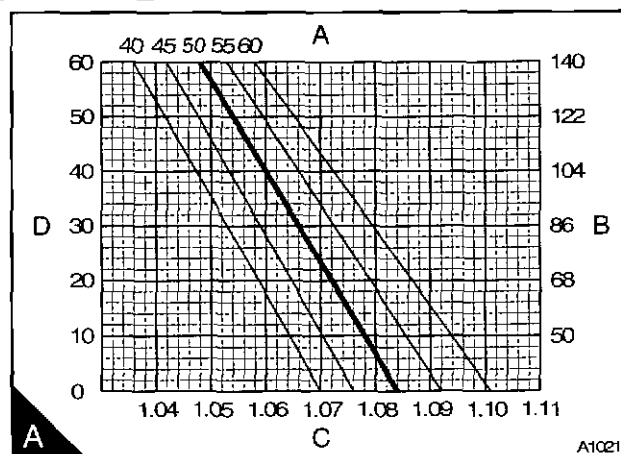

**Specific gravity chart**

A = Percentage antifreeze by volume

B = Mixture temperature in °F

C = Specific gravity

D = Mixture temperature in °C

# 4

## How to check the drive belt(s)

Renew a belt if it is worn or damaged. If twin belts are fitted, they must be renewed together.

To ensure maximum belt life, it is recommended that a belt tensioner gauge is used to check the belt tension. Fit the gauge (A1) at the centre of the longest free length and check the tension. If a "Burroughs" gauge is used, the correct tension is 355 N (80 lbf) 36 kgf. If the tension is 220 N (50 lbf) 22 kgf or below, adjust it to 355 N (80 lbf) 36 kgf as indicated below:

If a gauge is not available, press down the belt with the thumb at the centre of the longest free length and check the deflection (B). With moderate thumb pressure - 45N (10 lbf) 4,5 kgf - the correct deflection of the belt is 10 mm (3/8 in).

If twin belts are fitted, check/adjust the tension on the tighter belt.

### How to adjust the belt tension

- 1 Loosen the pivot fasteners (B1) of the alternator and the adjustment link fasteners (B2).
- 2 Change the position of the alternator to give the correct tension. Tighten the pivot fasteners of the alternator and the adjustment link fasteners.
- 3 Check the belt tension again to ensure that it is still correct. If a new belt is fitted, the belt tension must be checked again after the first 20 hours of operation.

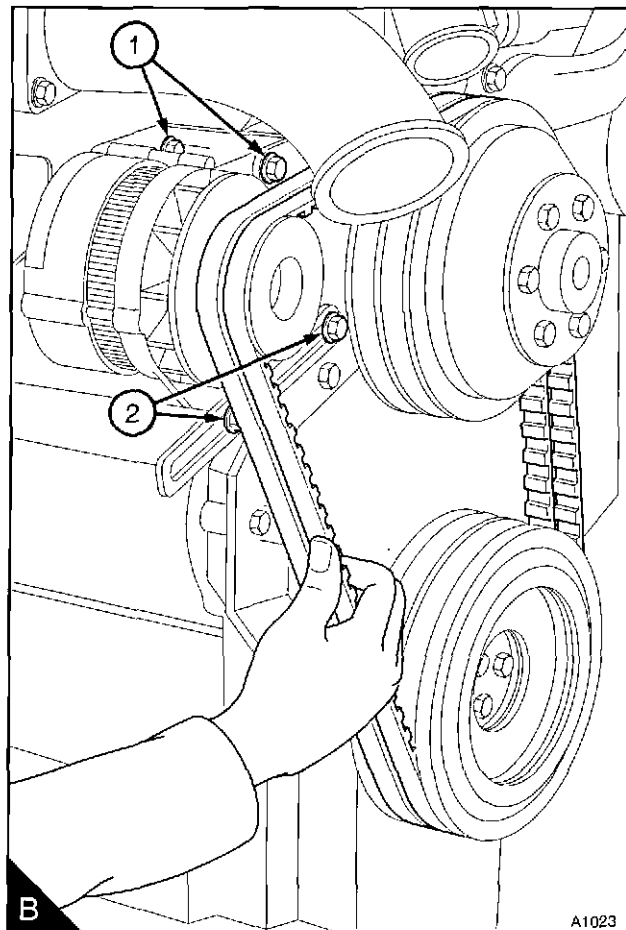
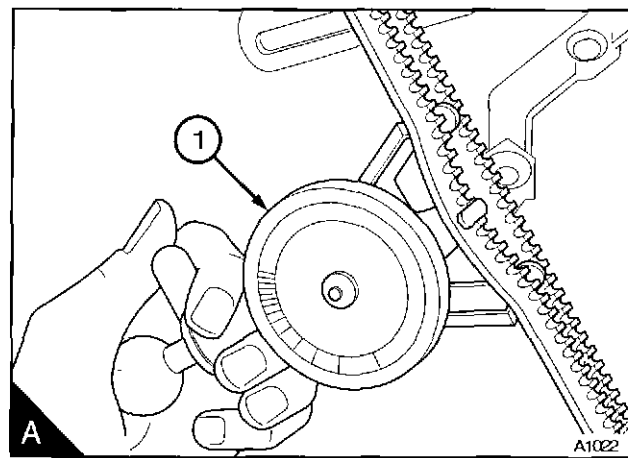

### How to clean the gauze strainer of the fuel lift pump

- 1 Release the fastener (A2) and remove the cover and the joint (A3) from the top of the fuel lift pump (A4). Remove the gauze strainer (A1). On some turbocharged engines, it will be necessary to remove the small heat shield which is fitted above the pump.
- 2 Wash carefully all of the sediment from the lift pump body.
- 3 Clean the gauze strainer, the joint and the cover.
- 4 Assemble the lift pump. Use a good joint and ensure that the lift pump body and the cover are fitted together correctly because leakage at this point will let air into the fuel system. Fit the heat shield, if one is fitted.
- 5 Eliminate the air from the fuel system through the filter vent point, see page 32.

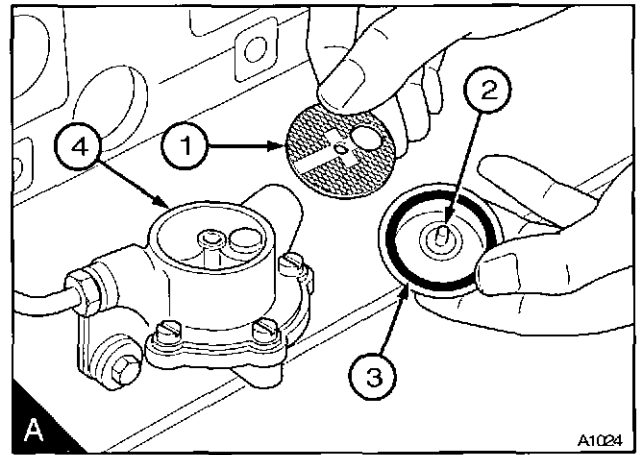

### Fuel pre-filter

A pre-filter, if fitted, is installed between the fuel tank and the engine. Check the pre-filter bowl for water at regular intervals and drain as necessary, see the schedule on page 18.

# 4

## How to renew the fuel filter

**Warning!** Discard the used canister and fuel oil in a safe place and in accordance with local regulations.

There are three types of fuel filter element in use: The separate element type where the filter element (A4) is held between the filter head and the bottom cover. The filter can have two elements (A).

The canister type where the filter element has an internal thread (B2) at the top and is fastened to a threaded adaptor in the filter head (B1).

A fuel filter with a quick release canister (C). The filter can have two canisters. Some engines are fitted with a pre-filter (C1) of the same type. This filter is fitted next to the main filter (C3), but connected in the fuel system before the fuel lift pump.

### Cautions:

- It is important that only the genuine Perkins parts are used. The use of a wrong canister or element can damage the fuel injection pump.
- The pre-filter and main filter canisters must be renewed at the same time.
- Do not allow dirt to enter the fuel system. Before a connection is disconnected, clean thoroughly the area around the connection. After a component has been disconnected, fit a suitable cover to all open connections.

### How to renew the element(s) of the separate element type

- 1 Clean the outside surfaces of the fuel filter assembly. If a drain tap (C2) is fitted to the bottom of the filter bowl, drain the fuel from the filter.
- 2 Hold the bottom cover of the filter element and release the setscrew (A3) which is fitted through the filter head (A1) above the centre of the element.
- 3 Lower the bottom cover of the filter.
- 4 Remove the element (A4) and discard it.
- 5 Clean the inside surfaces of the filter head and of the cover.
- 6 Renew the seals (A2) and (A5) and lightly lubricate them with clean fuel.
- 7 Put the bottom cover under the new element and hold the element squarely to the filter head. Ensure that the element is fitted in the centre against the joint in the filter head. With the assembly in this position, engage and tighten the setscrew.
- 8 Eliminate the air from the fuel filter, see page 32.

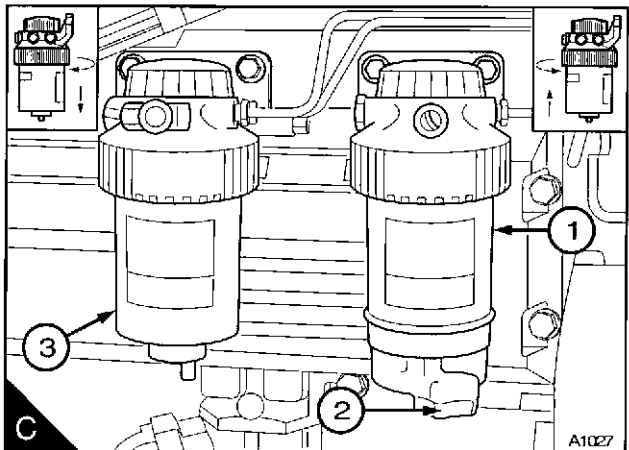
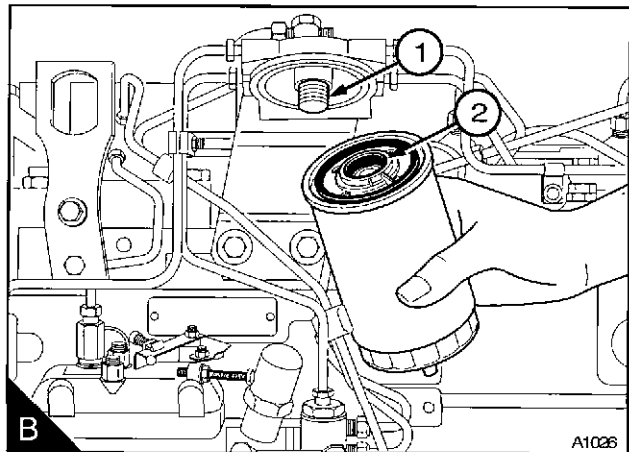
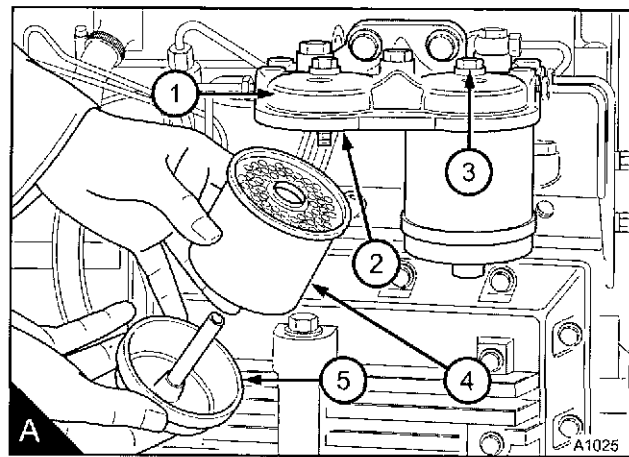

### How to renew the filter canister of the canister type

**Caution:** It is important that only the genuine Perkins fuel filter canister is used. The use of a wrong canister can cause damage to the fuel injection pump.

- 1 Thoroughly clean the outside surfaces of the fuel filter assembly.
- 2 Loosen the drain device (A1) at the bottom of the filter and allow the water/fuel to drain into a suitable container.
- 3 Use a strap wrench or similar tool to loosen the filter canister and remove the canister.
- 4 Ensure that the threaded adaptor (B1) is secure in the filter head and that the inside of the head is clean.

**Caution:** Some of the fuel filter canisters fitted in the factory have a special sealant applied to the threads of the adaptor. Filter canisters supplied in service have an inner seal assembly (B2) instead. The seal is held in position by a plastic clip. Damage to the fuel injection pump may occur if the canister seals are not fitted correctly.

- 5 Lubricate lightly the two top seals (B2) and (B3) of the new canister with clean fuel. Fit the new canister to the filter head and tighten, by hand only.
- 6 Eliminate the air from the fuel filter, see page 32.

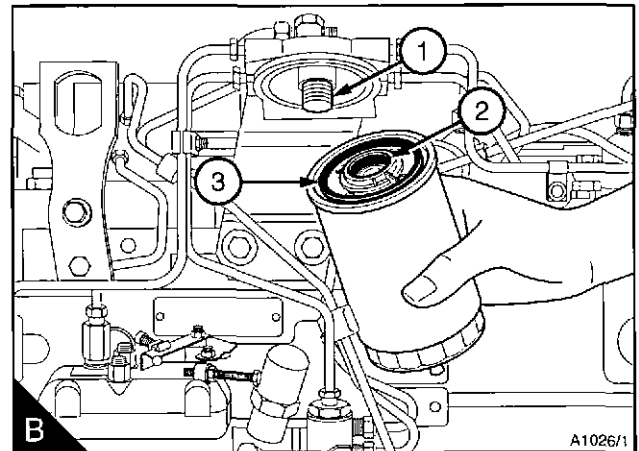
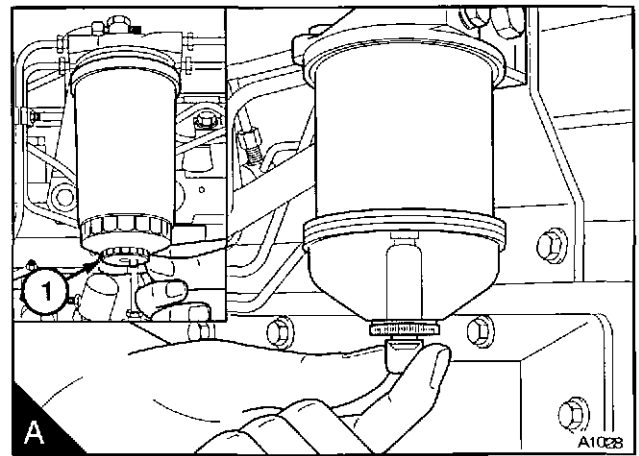

# 4

## How to renew the canister of the quick release canister type

**Caution:** Discard used fuel filters and any spilt fuel in a safe place and in accordance with local regulations.

**1** Thoroughly clean the outside surfaces of the filter assembly.

**2** Loosen the drain device (A8), or (A6) if a pre-filter is fitted, at the bottom of the canister or sediment bowl (A5) and allow the water or fuel to drain into a suitable container.

**Note:** If the filter does not have a drain device fitted release the cap (A2) on top of the filter head. Remove the nylon insert to lower the level of the fuel in the filter canister. This will prevent fuel spill when the clamp ring (A7) is released.

**3** Support the filter canister(s) (A4) and (A9) and rotate the clamp ring to the left (A1) and remove the clamp ring.

**4** Remove the canister from the filter head by a direct pull downwards (A1), and discard the old canister.

**5** If a sediment bowl is fitted, remove the bowl and thoroughly clean the cover of the bowl.

**6** Check the two 'O' ring seals of the sediment bowl for damage and renew them if necessary.

**7** Clean the threads of the sediment bowl and fit the bowl to the canister and tighten by hand only.

**8** Ensure the filter head is clean. Push the new canister fully into the filter head (A3).

**9** Support the canister, fit the clamp ring and rotate it to the right (A3) to fasten the canister to the filter head.

**10** If the nylon insert was removed to lower the fuel level in the filter, ensure that it is fitted correctly and fit the cap.

**11** Eliminate the air from the fuel filter, see page 32.

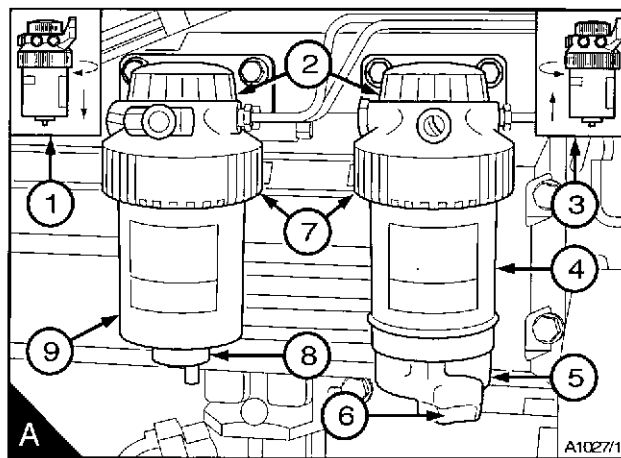

## Atomiser maintenance

**Caution:** A faulty atomiser must be renewed by a person who has had the correct training.

Regular maintenance of the atomisers is not necessary. The atomiser nozzles should be renewed and not cleaned, and renewed only if an atomiser fault occurs. Some of the problems that may indicate that new nozzles are needed are listed below:

Engine will not start or is difficult to start

Not enough power

Engine misfires or runs erratically

High fuel consumption

Black exhaust smoke

Engine knocks or vibration

Excessive engine temperature

### Atomiser fault

#### Warnings!

- If your skin comes into contact with high-pressure fuel, obtain medical assistance immediately.
- Keep away from moving parts during engine operation. Some moving parts cannot be seen clearly while the engine runs.

In order to find which atomiser is defective, operate the engine at a fast idle speed. Loosen and tighten the union nut (A1) of the high-pressure fuel pipe at each atomiser. Do not loosen the union nut more than half a turn. When the union nut of the defective atomiser is loosened, it has little or no effect on the engine speed.

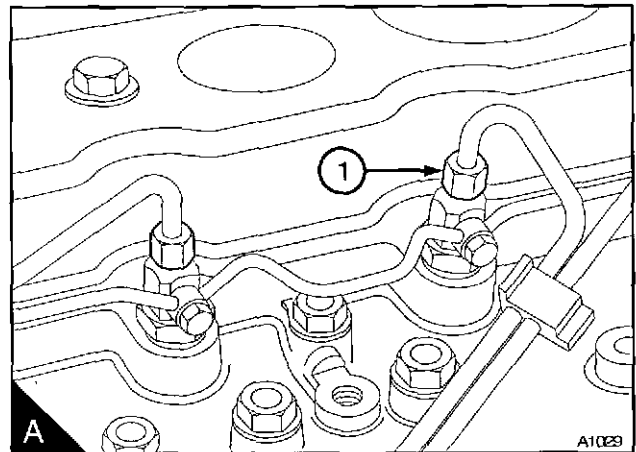

# 4

## How to remove and to fit an atomiser

### Consumable products:

POWERPART atomiser thread sealant

### To remove

#### Cautions:

- Atomisers must be removed and fitted by a person with the correct training.
- Do not allow dirt to enter the fuel system. Before a connection is disconnected, clean thoroughly the area around the connection. After a component has been disconnected, fit a suitable cover to all open connections.

1 Remove the fuel leak-off pipe from the connection (A2).

2 Remove the union nuts of the high-pressure pipe from the atomiser and from the fuel injection pump. Do not bend the pipe. If necessary, remove the pipe clamps. Fit a plastic cap (A1) to cover the fuel inlet connection.

**Caution:** Remove and discard the seat washer (A4). If the original seat washer remains in the recess for the atomiser, the nozzle protrusion will be incorrect when a new seat washer is added.

3 Release the clamp nut (A3) and remove the atomiser and its seat washer from the recess in the cylinder head.

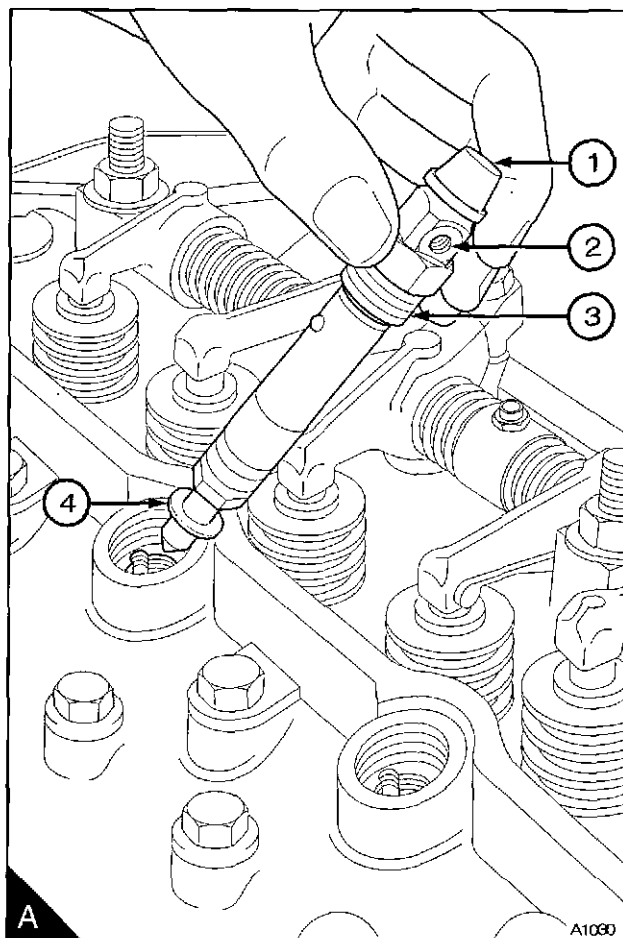

**To fit**

**1** Thoroughly clean the threads of the clamp nut and the cylinder head.

**Caution:** Do not allow any thread sealant to get below the clamp nut threads.

Ensure that the wire clip (A1) is in position. Put a 6 mm (0.24 in) long, 1 mm (0.04 in) wide bead of POWERPART Universal jointing compound, part number 1861117, around the first two threads of the atomiser clamp nut.

Put the new seat washer (A3) into the seat recess in the cylinder head.

Put the atomiser in position, ensure that the location ball (A4) is fitted in the groove (A2) correctly. Carefully engage the threads of the clamp nut with the threads in the cylinder head.

**Caution:** Do not move the clamp nut after it has been tightened, the seal that is made when torque has been applied will be broken and leakage past the atomiser seat may occur.

Ensure that the clamp nut is not cross threaded and tighten the nut gradually and evenly to 40 Nm (29 lbf ft) 4,1 kgf m. As the nut is tightened the atomiser will rotate clockwise as the ball moves in the slot. Remove any excess thread sealant.

**Caution:** Do not tighten the union nuts of the high-pressure pipes more than the recommended torque tension. If there is a leakage from the union nut, ensure that the pipe is correctly aligned with the atomiser inlet. Do not tighten the atomiser union nut more, as this can cause a restriction at the end of the pipe. This can affect the fuel delivery.

**2** Remove the plastic cap and fit the high-pressure fuel pipe and tighten the union nuts to 27 Nm (20 lbf ft) 2,8 kgf m. If necessary, fit the pipe clamps.

**3** Renew the sealing washers and fit the leak-off pipe. Tighten the M6 banjo bolt to 3,0 Nm (26.5 lbf in) 30,6 kgf cm.

**4** Operate the engine and check for leakage of fuel and air.

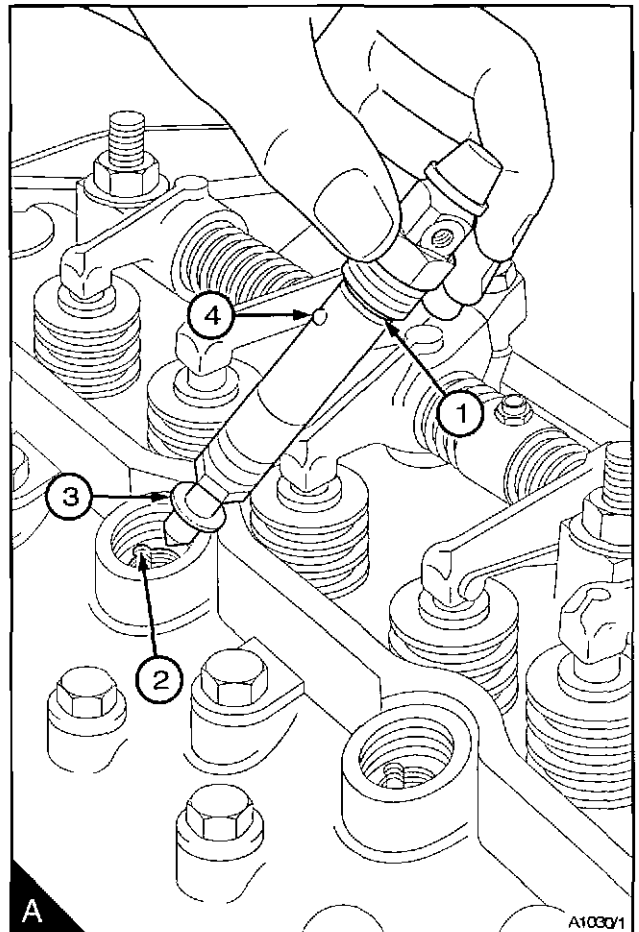

# 4

## How to eliminate air from the fuel system

**Warning!** If your skin comes into contact with high-pressure fuel, obtain medical assistance immediately.

If air enters the fuel system, it must be removed before the engine can be started.

Air can enter the system if:

- The fuel tank is drained during normal operation.
- The low-pressure fuel pipes are disconnected.
- A part of the low-pressure fuel system leaks during engine operation.

In order to eliminate air from the fuel system, proceed as follows: Vent screws are not fitted to the fuel injection pump. Air will usually be removed from the fuel pump automatically.

**Caution:** If the fuel system is empty or if the canister(s) of the fuel filter have been renewed, it will be necessary to eliminate air from the fuel system, especially the fuel injection pump.

**1** Loosen the vent plug on the filter head of the pre-filter (A2). Operate the priming lever of the fuel lift pump (C) until fuel, free of air, comes from the vent plug. Tighten the vent plug.

**Note:** If the drive cam of the fuel lift pump is at the point of maximum lift, it will not be possible to operate the priming lever. In this situation, the crankshaft must be rotated one revolution.

Loosen the vent screw (A1) on the main filter. Operate the priming lever of the fuel lift pump until fuel, free of air, comes from the banjo bolt. Tighten the vent screw.

**For filters with a separate element:** Loosen the vent plug (B1) or banjo bolt on the top of the filter head.

**2** Operate the priming lever of the fuel lift pump (C) until fuel, free of air, comes from the banjo bolt or vent plug. Tighten the banjo bolt or vent plug.

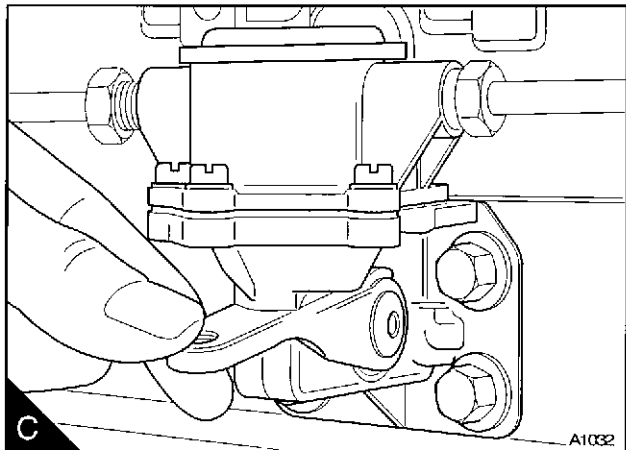
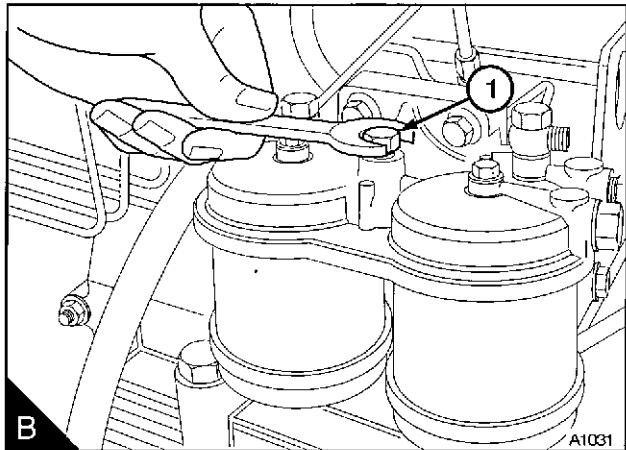
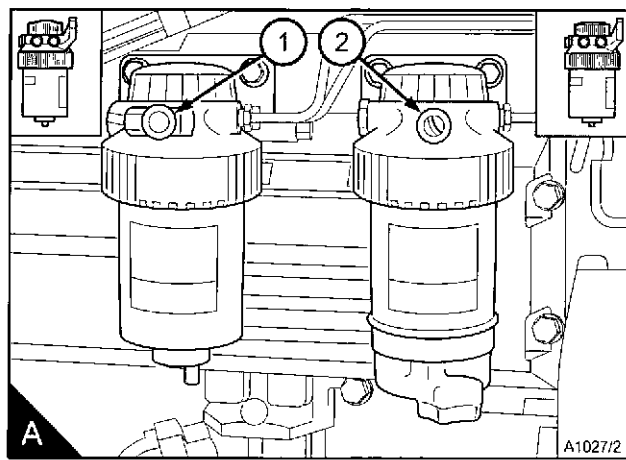

**Caution:** Use a spanner to prevent movement of the fuelled starting aid (A1) when the union nut (A2) is loosened or tightened.

**3** Loosen the union nut (A2) at the fuelled starting aid and operate the priming lever of the fuel lift pump until fuel, free of air, comes from the connection. Tighten the union nut at the starting aid.

**Note:** For Lucas fuel injection pumps: Loosen the union nut at the outlet connection of the low pressure fuel leak off pipe which is on top of the governor housing of the fuel injection pump. Operate the priming lever of the fuel lift pump until fuel, free of air, comes from the connection. Tighten the union nut.

**Caution:** Do not tighten the union nuts of the high-pressure pipes more than the recommended torque tension. If there is a leakage from the union nut, ensure that the pipe is correctly aligned with the atomiser inlet. Do not tighten the atomiser union nut more, as this can cause a restriction at the end of the pipe. This can affect the fuel delivery.

**4** Loosen the high-pressure connections at two of the atomisers (B1).

**Caution:** Damage to the fuel injection pump, battery and starter motor can occur if the starter motor is used excessively to eliminate air from the fuel system.

**5** Put the electrical system switch (A page 14) to the "ON" position. Ensure that the manual stop control, if one is fitted, is in the "run" position. Operate the starter motor until fuel, free from air, comes from the pipe connections. Tighten the high-pressure pipe connections to 27 Nm (20 lbf ft) 2,8 kgf m. Return the switch to the "OFF" position.

**6** The engine is now ready to start.

**Caution:** Operate the engine at low idle speed for a minimum of two minutes immediately after air has been removed from the fuel system. This will ensure that the pump is free of air and prevent any damage to the pumps internal parts by metal to metal contact.

If the engine runs correctly for a short time and then stops or runs roughly, check for air in the fuel system. If there is air in the fuel system, there is probably a leakage in the low pressure system.

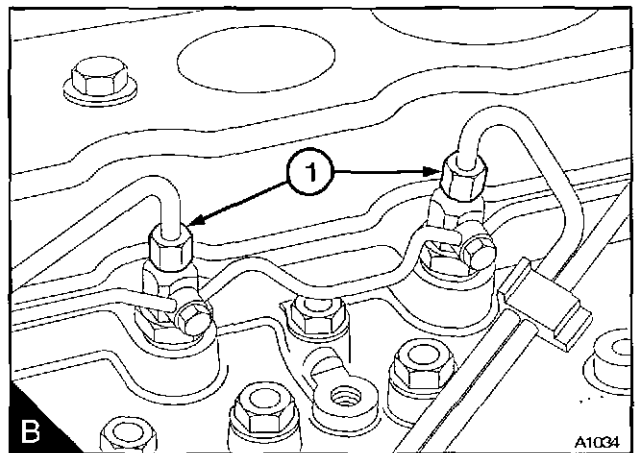
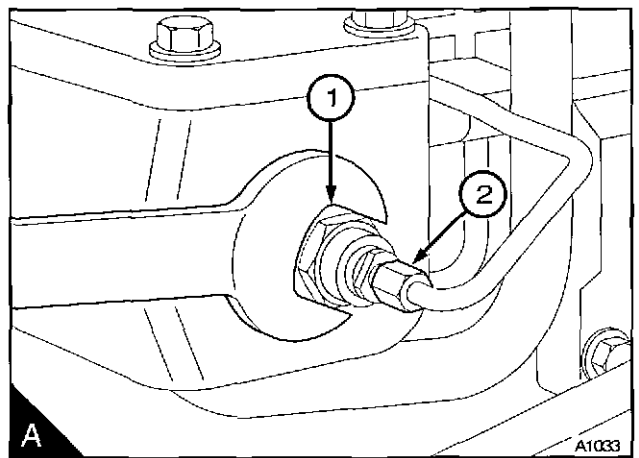

# 4

## How to renew the lubricating oil of the engine

**Warning!** Do not exceed the correct level of lubricating oil in the sump especially if a closed circuit breather is fitted to the engine. If there is too much lubricating oil, the excess must be drained to the correct level. An excess of lubricating oil could enter the breather valve. This could cause the engine speed to increase rapidly without control.

### Cautions:

- Discard the used lubricating oil in a safe place and in accordance with local regulations.
- Ensure that the application is on a level surface to ensure an accurate reading on the dipstick.

1 Operate the engine until it is warm.

2 Stop the engine, remove the sump drain plug (A1) and its "O" ring and drain the lubricating oil from the sump. Ensure that the "O" ring is not damaged. Fit the drain plug and its "O" ring and tighten the plug to 34 Nm (25 lbf ft) 3,5 kgf m.

3 Fill the sump to the mark (A2) on the dipstick with new and clean lubricating oil of an approved grade, see page 42.

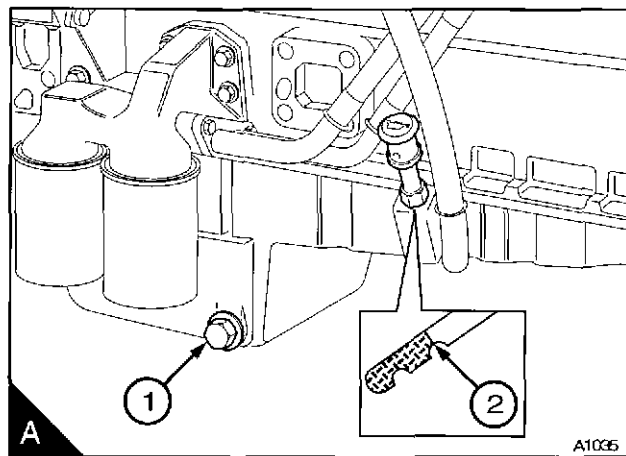

## How to renew the canister of the lubricating oil filter

**Warning!** Discard the used canister and lubricating oil in a safe place and in accordance with local regulations.

### Cautions:

- The canister contains a valve and special tube to ensure that lubricating oil does not drain from the filter. Therefore, ensure that the correct Perkins POWERPART canister is used.
- Ensure that the application is on a level surface to ensure an accurate reading on the dipstick.

The filter can have one or two canisters. When two canisters (A1) and (A2) are fitted, both must be renewed at the same time.

- 1 Put a tray under the filter to retain spilt lubricating oil.
- 2 Remove the filter canister with a strap wrench or similar tool. Ensure that the adaptor (B1) is secure in the filter head. Discard the canister.
- 3 Clean the filter head.
- 4 Add clean engine lubricating oil to the new canister. Allow the oil enough time to pass through the filter element.
- 5 Lubricate the top of the canister seal (B2) with clean engine lubricating oil.
- 6 Fit the new canister and tighten it by hand only. Do not use a strap wrench.

Ensure that there is lubricating oil in the sump. On turbocharged engines ensure that the engine will not start and operate the starter motor until oil pressure is obtained. To ensure that the engine will not start, either put the manual stop control in the "stop" position or disconnect the electrical stop control of the fuel injection pump. Oil pressure is indicated when the warning light is extinguished or by a reading on the gauge.

- 7 Operate the engine and check for leakage from the filter. When the engine has cooled, check the oil level on the dipstick and put more oil into the sump, if necessary.

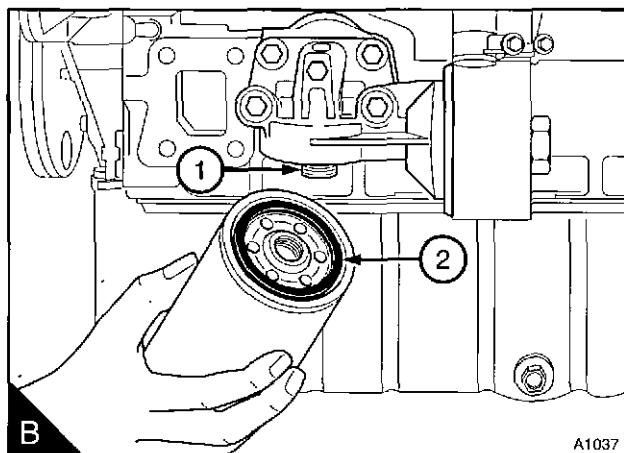
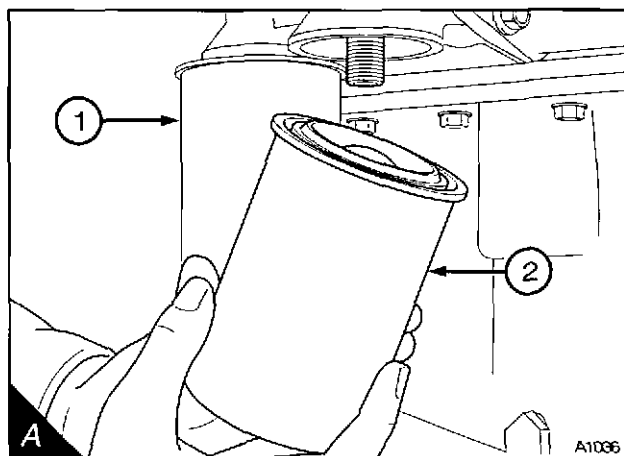

# 4

## How to maintain the engine open breather system

Some engines are fitted with an open breather which has a steel gauze (A2) to separate the oil from the crankcase gases before they leave the engine.

**Note:** It is not necessary to remove the body of the breather from the rocker cover to obtain access to the gauze.

- 1 Release the hose clip from the breather cover (A1).
- 2 Use a suitable lever between the outlet nozzle and the rocker cover to remove the breather cover from the body of the breather (A4). Ensure that the breather cover and the rocker cover are not damaged.
- 3 Use a cloth made damp with a proprietary cleaning fluid to clean the body of the breather.
- 4 Renew the "O" ring seal (A3).
- 5 Check that the inside of the breather pipe is clean. If the pipe is not clean, release the setscrews and remove the pipe. Wash the pipe with kerosene and dry it with low-pressure air.
- 6 Wash the steel gauze (A2) with kerosene and dry it with low-pressure air.
- 7 Fit the cover to the breather body, ensure that it is securely fitted.
- 8 Fit the breather pipe and tighten the hose clips.

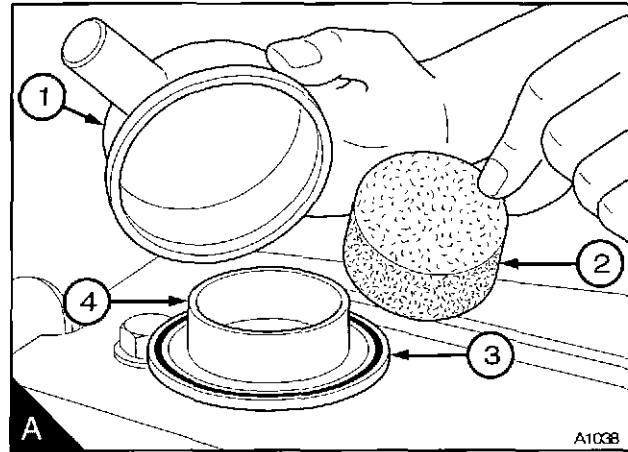

## How to maintain the closed engine breather system

**Caution:** It is very important that closed circuit breather systems are fitted correctly to the engine. Incorrect installation can cause extreme damage to the engine.

Below is a series of safety precautions that must be applied at all times.

- Do not operate the engine if any of the breather valve or the induction hoses are loose or disconnected as this could allow dirt into the engine and damage to the engine could occur.
- Do not operate the engine if any of the breather valve or the induction hoses are bent such as to cause a restriction to the gases that flow through them. This can cause lubricating oil to enter the cylinders through the breather valve.
- Do not alter the design or any settings for the closed breather system.
- Ensure that the vent hole (A1) is not restricted during service.

The closed circuit breather used on the New 1000 Series engine comprises a body (A4) and a valve assembly (A5). The whole assembly must be renewed every complete overhaul of the engine or 8000 hours.

### To renew the engine breather assembly

- 1 Release the three hose clips (A2) and remove the hoses.
- 2 Release the two setscrews (A3) and remove the breather assembly.
- 3 Clean the inside of the pipes with a propriety cleaning fluid and dry them.
- 4 Fit a new breather assembly. Fit and tighten the two setscrews. Fit the three hoses in their correct positions on the breather and tighten the three hose clips.

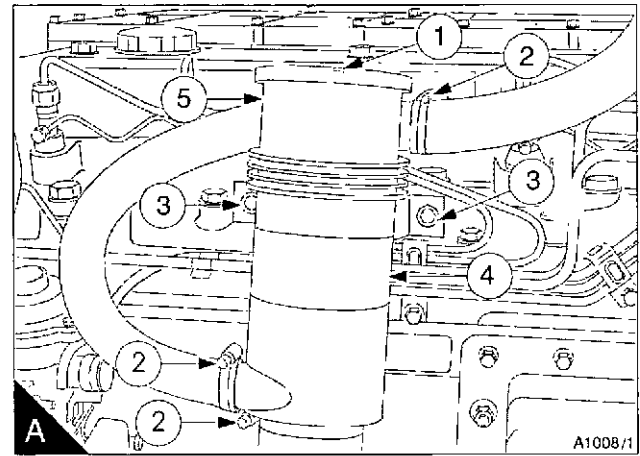

# 4

## Air filter

**Caution:** Do not operate the engine if there is a blockage in the air filter or the induction hose. This can cause lubricating oil to enter the cylinders through the breather valve.

Environmental conditions have an important effect on the frequency at which the air filter needs service.

Certain air filters have a separate dust bowl (A1) which must be cleaned at intervals. The amount of dust in the bowl shows if it has been removed at the correct time for the conditions of operation. Do not let dust completely fill the bowl, because this will reduce the life of the filter element (A2).

Certain air filters have automatic dust valves (B1) through which dust is expelled from the filter. The rubber dust valve must be kept clean. Ensure that the sides of the valves close completely together and that they can separate freely.

If a restriction indicator (C) is fitted, it will indicate precisely when the air filter element needs service. This prevents the premature removal of the filter element which causes extra cost or late removal of the element which can cause loss of engine power. The filter element must be cleaned or renewed according to the manufacturers recommendations.

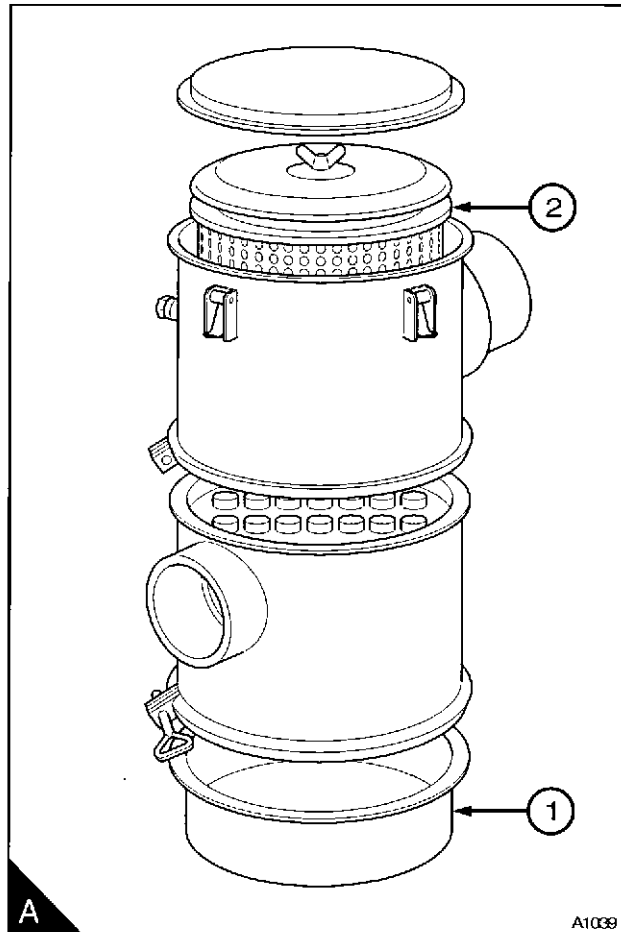

## Restriction indicator

The restriction indicator is fitted on the air filter outlet or between the air filter and the induction manifold.

When the red warning indicator (C1) is seen through the clear panel (C2) after the engine has stopped, the air filter element must be removed for service.

After a clean element has been fitted, press the rubber bottom (C3) or the button (C4) of the restriction indicator to reset the red warning indicator.

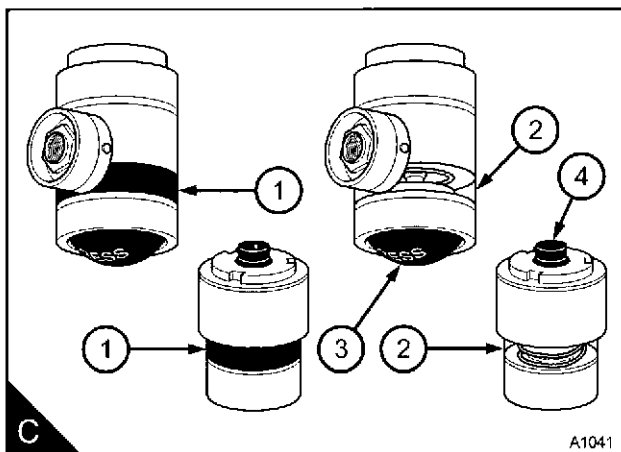
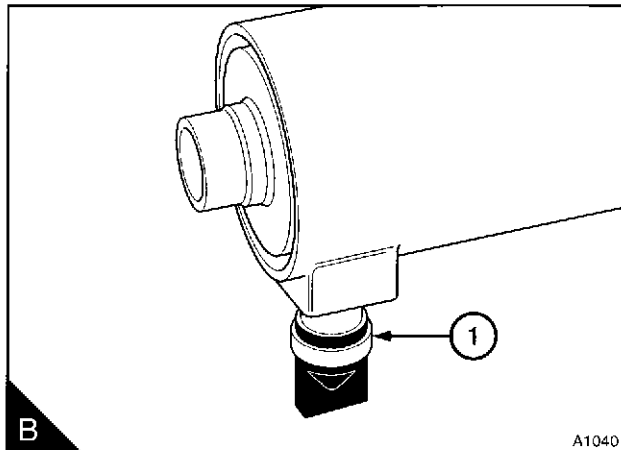

## How to check the valve tip clearances

These are checked between the top of the valve stem and the rocker lever (A), with the engine hot or cold. The correct clearance for inlet valves is 0,20 mm (0.008 in) and 0,45 mm (0.018 in) for exhaust valves. The valve positions are shown at (B).

The sequence of valves from number 1 cylinder is shown in the table below.

**Note:** Number 1 cylinder is at the front of the engine.

### Four cylinder engines

- 1 Rotate the crankshaft in the normal direction of rotation until the inlet valve (B7) of number 4 cylinder has just opened and the exhaust valve (B8) of the same cylinder has not closed completely. Check the clearances of the valves (B1 and B2) of number 1 cylinder and adjust them, if necessary.
- 2 Set the valves (B3 and B4) of number 2 cylinder as indicated above for number 4 cylinder. Then check / adjust the clearances of the valves (B5 and B6) of number 3 cylinder.
- 3 Set the valves (B1 and B2) of number 1 cylinder. Then check / adjust the clearances of the valves (B7 and B8) of number 4 cylinder.
- 4 Set the valves (B5 and B6) of number 3 cylinder. Then check / adjust the clearances of the valves (B3 and B4) of number 2 cylinder.

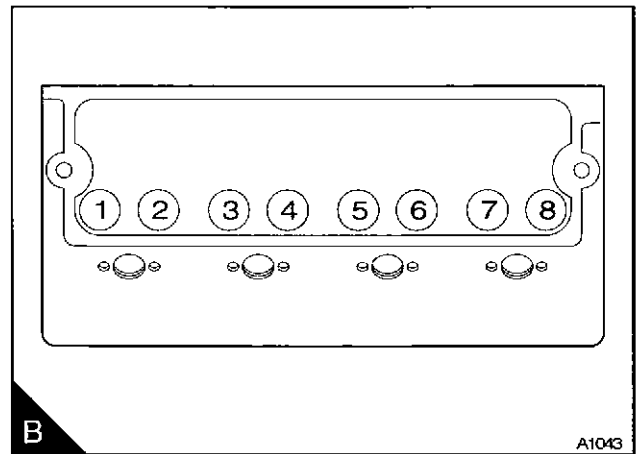
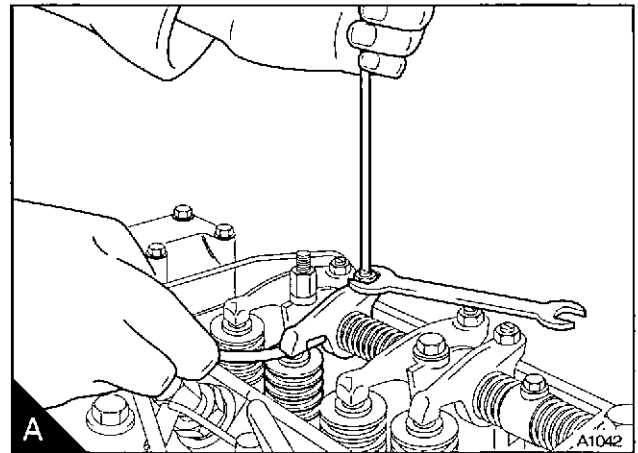

Cylinder and valve number	1		2		3		4	
	1	2	3	4	5	6	7	8
Valve I = Inlet E = Exhaust	I	E	I	E	I	E	I	E

# 4

## Six cylinder engines

**1** Rotate the crankshaft in the normal direction of rotation until the inlet valve (A11) of number 6 cylinder has just opened and the exhaust valve (A12) of the same cylinder has not closed completely. Check the clearances of the valves (A1 and A2) of number 1 cylinder and adjust them, if necessary.

**2** Set the valves (A3 and A4) of number 2 cylinder as indicated above for number 6 cylinder. Then check / adjust the clearances of the valves (A9 and A10) of number 5 cylinder.

**3** Set the valves (A7 and A8) of number 4 cylinder. Then check / adjust the clearances of the valves (A5 and A6) of number 3 cylinder.

**4** Set the valves (A1 and A2) of number 1 cylinder. Then check / adjust the clearances of the valves (A11 and A12) of number 6 cylinder.

**5** Set the valves (A9 and A10) of number 5 cylinder. Then check / adjust the clearances of the valves (A3 and A4) of number 2 cylinder.

**6** Set the valves (A5 and A6) of number 3 cylinder. Then check / adjust the clearances of the valves (A7 and A8) of number 4 cylinder.

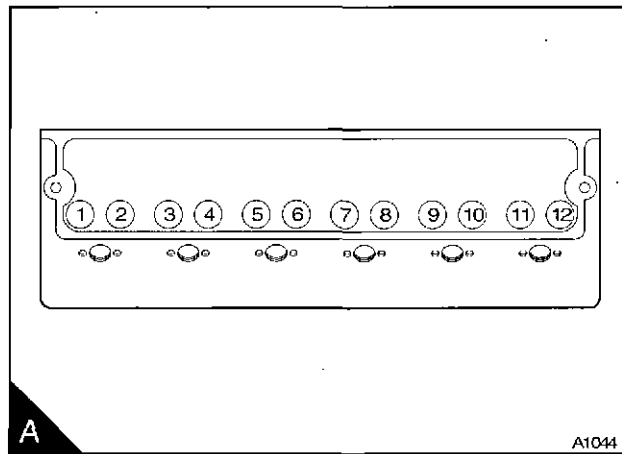

Cylinder and valve number	1		2		3		4		5		6	
	1	2	3	4	5	6	7	8	9	10	11	12
Valve I = Inlet E = Exhaust	I	E	I	E	I	E	I	E	I	E	I	E

# 5

## Engine fluids

### Fuel specification

To get the correct power and performance from your engine, use good quality fuel. The recommended fuel specification for Perkins engines is indicated below:

Cetane number.....	45 minimum
Viscosity .....	2.0/4.5 centistokes at 40°C
Density.....	0,835/0,860 kg/litre at 15°C
Sulphur .....	0.20% of mass, maximum
Distillation .....	85% at 350°C

**Cetane number** indicates ignition performance. A fuel with a low cetane number can cause cold start problems and affect combustion.

**Viscosity** is the resistance to flow and engine performance can be affected if it is outside the limits.

**Density:** A lower density reduces engine power, a higher density increases engine power and exhaust smoke.

**Sulphur:** A high amount of sulphur (not normally found in Europe, North America or Australasia) can cause engine wear.

Percentage of sulphur in the fuel (%)	Oil change interval
<0.5	Normal
0.5 to 1.0	0.75 of normal
> 1.0	0.50 of normal

**Distillation:** This is an indication of the mixture of different hydrocarbons in the fuel. A high ratio of light-weight hydrocarbons can affect the combustion characteristics.

### Low temperature fuels

Special winter fuels may be available for engine operation at temperatures below 0°C. These fuels have a lower viscosity and also limit the wax formation in the fuel at low temperatures. If wax formation occurs, this could stop the fuel flow through the filter.

If you need advice on adjustments to an engine setting or to the lubricating oil change periods which may be necessary because of the standard of the available fuel, consult your nearest Perkins distributor or one of the companies listed on page 8.

### Aviation kerosene fuels

**Warning!** Aviation kerosene fuels are more flammable than diesel fuel and need careful storage. Ensure that the relevant safety precautions are conformed to.

These fuels can be used but they can affect engine performance. It is recommended that you consult the Perkins Technical Service Department at Peterborough.

# 5

## Lubricating oil specification

If you need advice on adjustments to an engine setting or to the lubricating oil change periods which may be necessary because of the standard of available fuel, consult your nearest Perkins distributor or the Technical Service Department of one of the companies listed on page 8.

Use only a good quality lubricating oil to the relevant specification as shown in the table below.

**Caution:** The type of lubricating oil to be used may be affected by the quality of the fuel which is available. For further details see "Fuel specification" on page 41 and the preventive maintenance schedules on page 18.

Always ensure that the correct viscosity grade of lubricating oil is used for the ambient temperature range in which the engine will run as shown in the chart (A).

## Lubricating oil specification

Engine type	Specifications	
	API CF4	API CG4
	or	or
	ACEA E2	ACEA E3
Naturally aspirated	●	●(1)
Turbocharged	●	●(1)

(1) Recommended for applications which have engines that operate at high load conditions. Refer to your equipment supplier's handbook for the application or the table on page 19 for guidance. If further advice is necessary, refer to your nearest Perkins distributor.

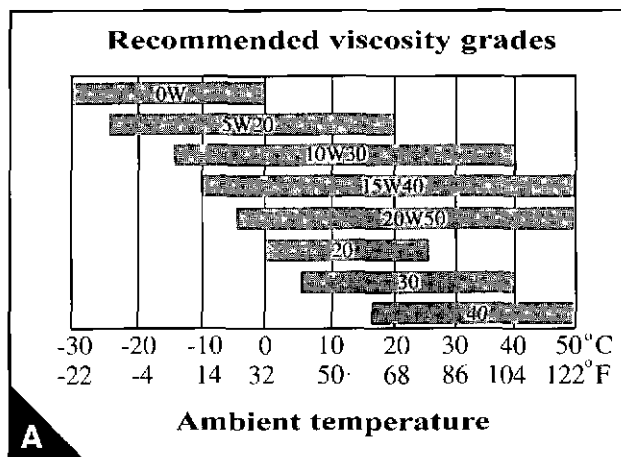

## Coolant specification

The quality of the coolant which is used can have a great effect on the efficiency and life of the cooling system. The recommendations indicated below can help to maintain a good cooling system and to protect it against frost and/or corrosion.

If the correct procedures are not used, Perkins cannot be held responsible for damage caused by frost or corrosion.

**Caution:** *An antifreeze which contains the correct inhibitor must be used at all times to prevent damage to the engine by corrosion, because of the use of aluminium in the coolant circuit,*

- *If frost protection is not necessary, it is still extremely important to use an approved antifreeze mixture because this gives a protection against corrosion and also raises the boiling point of the coolant.*
- *If the approved antifreeze mixture is not available, add a correct mixture of corrosion inhibitor to the water. If the correct inhibitor is not used, the engine will be damaged by corrosion. If there is doubt about the corrosion inhibitor to be used, it is recommended that you consult the Perkins Service Department, Peterborough, see the address on page 8.*

**Note:** If combustion gases are released into the coolant circuit, the coolant must be renewed after repair of the fault.

The antifreeze which is recommended for this engine is the latest POWERPART Antifreeze, see page 52. This antifreeze contains the correct corrosion inhibitor which is especially suitable for this engine.

If it is possible, use clean soft water in the coolant.

The quality of the antifreeze coolant must be checked at least once a year, for example, at the beginning of the cold period. The coolant must be renewed every two years.

The antifreeze mixture must consist of equal quantities of antifreeze and water. The corrosion inhibitor in the antifreeze will be diluted if a concentration of less than 50% of antifreeze is used. Concentrations of more than 50% of antifreeze may have an adverse effect on the performance of the coolant.

---

# 6

## Fault diagnosis

*Continued*

# 6

## Problems and possible causes

Problem	Possible causes	
	Checks by the user	Checks by the workshop personnel
The starter motor turns the engine too slowly	1, 2, 3, 4	
The engine does not start	5, 6, 7, 8, 9, 10, 12, 14, 15, 17	13, 34, 35, 36, 37, 38, 40, 42, 43, 44
The engine is difficult to start	5, 7, 8, 9, 10, 11, 12, 14, 15, 16, 17, 19	13, 34, 36, 37, 38, 40, 42, 43, 44
Not enough power	8, 9, 10, 11, 12, 16, 17, 18, 19, 20, 21	13, 34, 36, 37, 38, 39, 42, 43, 44, 61, 63, 64
Misfire	8, 9, 10, 12, 15, 20, 22	13, 34, 36, 37, 38, 39, 40, 41, 43
High fuel consumption	11, 15, 17, 18, 19, 21, 22	13, 34, 36, 37, 38, 39, 40, 42, 43, 44, 63
Black exhaust smoke	11, 15, 17, 19, 21, 22	13, 34, 36, 37, 38, 39, 40, 42, 43, 44, 61, 63
Blue or white exhaust smoke	4, 15, 21, 23	36, 37, 38, 39, 42, 44, 45, 52, 58, 62
The pressure of the lubricating oil is too low	4, 24, 25, 26	46, 47, 48, 50, 51, 59
The engine knocks	9, 15, 17, 20, 22, 23	13, 36, 37, 40, 42, 44, 46, 52, 53, 60
The engine runs erratically	7, 8, 9, 10, 11, 12, 15, 16, 18, 20, 22, 23	13, 34, 38, 40, 41, 44, 52, 60
Vibration	18, 20, 27, 28	13, 34, 38, 39, 40, 41, 44, 52, 54
The pressure of the lubricating oil is too high	4, 25	49
The engine temperature is too high	11, 15, 19, 27, 29, 30, 32	13, 34, 36, 37, 39, 52, 55, 56, 57, 64
Crankcase pressure	31, 33	39, 42, 44, 45, 52
Bad compression	11, 22	37, 39, 40, 42, 43, 44, 45, 53, 60
The engine starts and stops	10, 11, 12	

**List of possible causes**

- 1 Battery capacity low.
- 2 Bad electrical connections.
- 3 Fault in starter motor.
- 4 Wrong grade of lubricating oil.
- 5 Starter motor turns engine too slowly.
- 6 Fuel tank empty.
- 7 Fault in stop control.
- 8 Restriction in a fuel pipe.
- 9 Fault in fuel lift pump.
- 10 Dirty fuel filter element.
- 11 Restriction in filter/cleaner or air induction system.
- 12 Air in fuel system.
- 13 Fault in atomisers or atomisers of an incorrect type.
- 14 Cold start system used incorrectly.
- 15 Fault in cold start system.
- 16 Restriction in fuel tank vent.
- 17 Wrong type or grade of fuel used.
- 18 Restricted movement of engine speed control.
- 19 Restriction in exhaust pipe.
- 20 Engine temperature is too high.
- 21 *Engine temperature is too low.*
- 22 Valve tip clearances are incorrect.
- 23 Too much oil or oil of wrong specification used in wet type oil cleaner.
- 24 Not enough lubricating oil in sump.
- 25 Defective gauge.
- 26 Dirty lubricating oil filter element.
- 27 Fan damaged.
- 28 Fault in engine mounting or flywheel housing.
- 29 Too much lubricating oil in sump.
- 30 Restriction in air or water passages of radiator.
- 31 Restriction in breather pipe.
- 32 Insufficient coolant in system.
- 33 *Vacuum pipe leaks or fault in exhauster.*
- 34 Fault in fuel injection pump.
- 35 Broken drive on fuel injection pump.
- 36 Timing of fuel injection pump is incorrect.
- 37 Valve timing is incorrect.
- 38 Bad compression.
- 39 Cylinder head gasket leaks.
- 40 Valves are not free.
- 41 Wrong high-pressure pipes.
- 42 Worn cylinder bores.
- 43 Leakage between valves and seats.
- 44 Piston rings are not free or they are worn or broken.
- 45 Valve stems and/or guides are worn.
- 46 *Crankshaft bearings are worn or damaged.*
- 47 Lubricating oil pump is worn.
- 48 Relief valve does not close.
- 49 Relief valve does not open.
- 50 Relief valve spring is broken.
- 51 Fault in suction pipe of lubricating oil pump.
- 52 Piston is damaged.
- 53 Piston height is incorrect.
- 54 Flywheel housing or flywheel is not aligned correctly.
- 55 Fault in thermostat or thermostat is of an incorrect type.
- 56 Restriction in coolant passages.
- 57 Fault in water pump.
- 58 Valve stem seal is damaged (if there is one fitted).
- 59 Restriction in sump strainer.
- 60 Valve spring is broken.
- 61 Turbocharger impeller is damaged or dirty.
- 62 Lubricating oil seal of turbocharger leaks.
- 63 Induction system leaks (turbocharged engines).
- 64 Turbocharger waste-gate does not work correctly (if there is one fitted).

# 7

## Engine preservation

### Introduction

The recommendations indicated below are designed to prevent damage to the engine when it is withdrawn from service for a prolonged period. Use these procedures after the engine is withdrawn from service. The instructions for the use of POWERPART products are given on the outside of each container.

### Procedure

- 1 Completely clean the outside of the engine.
- 2 When a preservative fuel is to be used, drain the fuel system and fill it with the preservative fuel. POWERPART Lay-Up 1 can be added to the normal fuel to change it to a preservative fuel. If preservative fuel is not used, the system can be kept full with normal fuel but the fuel must be drained and discarded at the end of the storage period together with the fuel filter element(s).
- 3 Operate the engine until it is warm. Then correct leakages of fuel, lubricating oil or air. Stop the engine and drain the lubricating oil from the sump.
- 4 Renew the canister(s) of the lubricating oil filter.
- 5 Fill the sump to the full mark on the dipstick with new and clean lubricating oil and add POWERPART Lay-Up 2 to the oil to protect the engine against corrosion. If POWERPART Lay-Up 2 is not available, use a correct preservative fluid instead of the lubricating oil. If a preservative fluid is used, this must be drained and the lubricating oil sump must be filled to the correct level with normal lubricating oil at the end of the storage period.
- 6 Drain the cooling system, see page 21. In order to protect the cooling system against corrosion, fill it with an approved antifreeze mixture because this gives a protection against corrosion, see page 43.

**Caution:** *Certain corrosion inhibitor mixtures could cause damage to some engine components. It is recommended that you consult the Perkins Service Department, Peterborough.*

- 7 Operate the engine for a short period in order to circulate the lubricating oil and the coolant in the engine.
- 8 Disconnect the battery. Then put the battery into safe storage in a fully charged condition. Before the battery is put into storage, protect its terminals against corrosion. POWERPART Lay-Up 3 can be used on the terminals.

9 Clean the engine breather pipe (if one is fitted) and seal the end of the pipe.

10 Remove the atomisers and spray POWERPART Lay-up 2 for one to two seconds into each cylinder bore with the piston at BDC.

11 Slowly turn the crankshaft one revolution and then fit the atomisers, refer to page 30.

12 Remove the air filter. Then, if necessary, remove the pipe(s) installed between the air filter and induction manifold or turbocharger. Spray POWERPART Lay-Up 2 into the induction manifold or turbocharger. It is recommended that the spray time for the turbocharger is 50% longer than the spray time for the manifold, which is indicated on the container label. Seal the manifold or the turbocharger with waterproof tape.

13 Remove the exhaust pipe. Spray POWERPART Lay-Up 2 into the exhaust manifold or the turbocharger. It is recommended that the spray time for the turbocharger is 50% longer than the spray time for the manifold, which is indicated on the container label. Seal the manifold or the turbocharger with waterproof tape.

14 If the lubricating oil filler is fitted onto the rocker cover, remove the filler cap. If the lubricating oil filler is not fitted onto the rocker cover, remove the rocker cover. Spray POWERPART Lay-Up 2 around the rocker shaft assembly. Fit the filler cap or rocker cover.

15 Seal the vent pipe of the fuel tank or the fuel filler cap with waterproof tape.

16 Remove the drive belts and put them into storage.

17 In order to prevent corrosion, spray the engine with POWERPART Lay-Up 3. Do not spray the area inside the alternator cooling fan.

*Continued*

# 7

---

**Caution:** After a period in storage, but before the engine is started, operate the starter motor with the stop switch (A page 14) held in the "STOP" position until oil pressure is indicated. Oil pressure is indicated when the low pressure warning light is extinguished. If a solenoid stop control is used on the fuel injection pump, it must be disconnected for this operation.

If the engine protection is done correctly according to the above recommendations, no corrosion damage will normally occur. Perkins are not responsible for damage which may occur when an engine is in storage after a period in service.

---

# 8

## Parts and service

### Introduction

If problems occur with your engine or with the components fitted onto it, your Perkins distributor can make the necessary repairs and will ensure that only the correct parts are fitted and that the work is done correctly.

Certain components can be supplied by your Perkins distributor through the Perkins POWERPART EXCHANGE COMPONENTS. These will enable you to reduce the cost of certain repairs.

### Service literature

Workshop manuals, installation drawings and other service publications are available from your Perkins distributor at a nominal cost.

### Training

Local training for the correct operation, service and overhaul of engines is available at certain Perkins distributors. If special training is necessary, your Perkins distributor can advise you how to obtain it at the Perkins Customer Training Department, Peterborough, or other main centres.

## **POWERPART recommended consumable products**

Perkins have made available the products recommended below in order to assist in the correct operation, service and maintenance of your engine and your machine. The instructions for the use of each product are given on the outside of each container. These products are available from your Perkins distributor.

### **POWERPART Antifreeze**

Protects the cooling system against frost and corrosion. Part number 21825166.

### **POWERPART Easy Flush**

Cleans the cooling system. Part number 21825001.

### **POWERPART Gasket and flange sealant**

To seal flat faces of components where no joint is used. Especially suitable for aluminium components. Part number 21820518.

### **POWERPART Gasket remover**

An aerosol for the removal of sealants and adhesives. Part number 21820116.

### **POWERPART Griptite**

To improve the grip of worn tools and fasteners. Part number 21820129.

### **POWERPART Hydraulic threadseal**

To retain and seal pipe connections with fine threads. Especially suitable for hydraulic and pneumatic systems. Part number 21820121.

### **POWERPART Industrial grade super glue**

Instant adhesive designed for metals, plastics and rubbers. Part number 21820125.

### **POWERPART Lay-Up 1**

A diesel fuel additive for protection against corrosion. Part number 1772204.

### **POWERPART Lay-Up 2**

Protects the inside of the engine and of other closed systems. Part number 1762811.

### **POWERPART Lay-Up 3**

Protects outside metal parts. Part number 1734115.

### **POWERPART Metal repair putty**

Designed for external repair of metal and plastic. Part number 21820126.

### **POWERPART Pipe sealant and sealant primer**

To retain and seal pipe connections with coarse threads. Pressure systems can be used immediately. Part number 21820122.

### **POWERPART Radiator stop leak**

For the repair of radiator leaks. Part number 21820127.

### **POWERPART Retainer (high strength)**

To retain components which have an interference fit. Currently Loctite 638. Part number 21820638.

### **POWERPART Safety cleaner**

General cleaner in an aerosol container. Part number 21820128.

### **POWERPART Silicone adhesive**

An RTV silicone adhesive for application where low pressure tests occur before the adhesive sets. Used for sealing flange where oil resistance is needed and movement of the joint occurs. Part number 21826038.

### **POWERPART Silicone RTV sealing and jointing compound**

Silicone rubber sealant which prevents leakage through gaps. Currently Hylosil. Part number 1861108.

### **POWERPART Stud and bearing lock**

To provide a heavy duty seal to components that have a light interference fit. Part number 21820119 or 21820120.

### **POWERPART Threadlock and nutlock**

To retain small fasteners where easy removal is necessary. Part number 21820117 or 21820118.

### **POWERPART Universal jointing compound**

Universal jointing compound which seals joints. Currently Hylomar. Part number 1861117.

# 9

## General data

### Engine

#### Number of cylinders

AJ, AK, AM, AP, AQ, AR, AS ..... 4  
YG, YH, YJ, YK ..... 6

Cylinder arrangement ..... In line  
Cycle ..... Four stroke

Direction of rotation ..... Clockwise from the front

#### Induction system

AJ, AP, AR, AS, YG ..... Naturally aspirated  
AK, AQ, YH ..... Turbocharged  
AM, YJ, YK ..... Turbocharged,intercooled

Combustion system ..... Direct injection

#### Nominal bore

AJ, AK, AM, AP, AQ, YG, YH, YJ, YK ..... 100 mm (3.937 in)  
AR, AS ..... 103 mm (4.055 in)

#### Stroke

AJ, AK, AM, AP, AQ, AR, AS, YG, YH, YJ, YK ..... 127 mm (5.00 in)

#### Compression ratio

AJ, AK, AM, AP, AQ, YG, YH, YJ, YK ..... 17.25:1  
AR, AS ..... 18.5:1

#### Cubic capacity

AJ, AK, AM, AP, AQ ..... 4 litres (243 in<sup>3</sup>)  
AR, AS ..... 4,2 litres (258 in<sup>3</sup>)  
YG, YH, YJ, YK ..... 6 litres (365 in<sup>3</sup>)

#### Firing order

AJ, AK, AM, AP, AQ, AR, AS ..... 1, 3, 4, 2  
YG, YH, YJ, YK ..... 1, 5, 3, 6, 2, 4

#### Valve tip clearances (hot or cold)

Inlet ..... 0,20 mm  
Exhaust ..... 0,45 mm

#### Lubricating oil pressure<sup>(1)</sup>

Engines with piston cooling jets ..... 280 kPa (40 lbf/in<sup>2</sup>) 2,5 kgf/cm<sup>2</sup>  
Engines types AR and AS ..... 207 kPa (30 lbf/in<sup>2</sup>) 2,1 kgf/cm<sup>2</sup>  
Engines without piston cooling jets ..... 207 kPa (30 lbf/in<sup>2</sup>) 2,1 kgf/cm<sup>2</sup>

Direction of rotation ..... Clockwise from the front

(1) Minimum at maximum engine speed and normal engine temperature

CALIFORNIA

Proposition 65 Warning

Diesel engine exhaust and some of its constituents are known to the State of California to cause cancer, birth defects, and other reproductive harm.

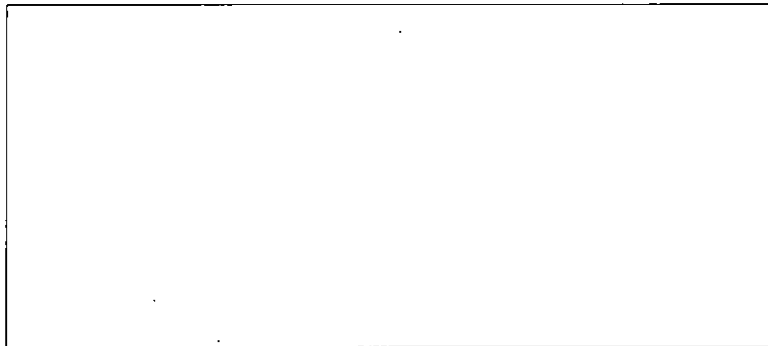

**Perkins Engines Company Limited**  
Peterborough PE1 5NA England