

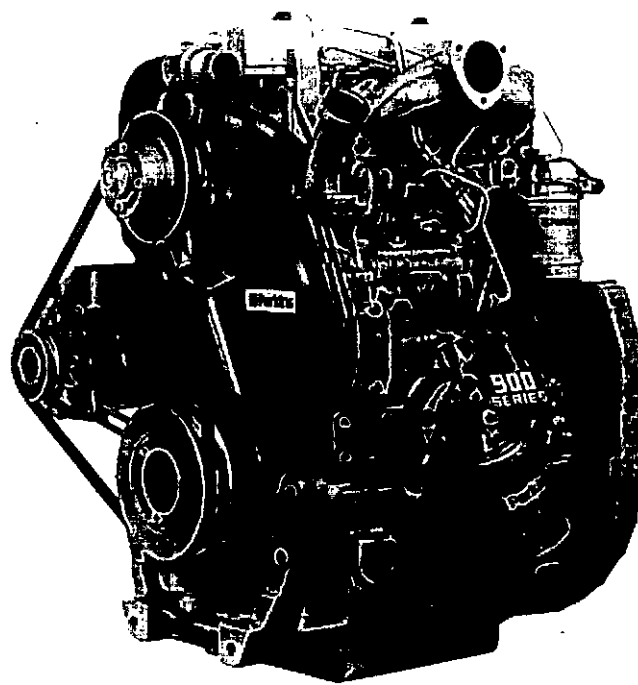

User's Handbook



900 Series
TPD 1325E Issue 2

VARITYPerkins

Perkins 900 Series

USER'S HANDBOOK

903.27 3 cylinder, naturally aspirated, diesel engines
for industrial and agricultural applications

Publication TPD 1325E issue 2.
(c) Perkins Group Limited 1995, all rights reserved.
Published in October 1995 by Technical Publications,
Perkins International Limited, Peterborough PE1 5NA, England.

*This publication is written in
Perkins Approved Clear English*

PACE

Contents

General information	1
Engine views	2
Operation instructions	3
Preventive maintenance	4
Engine fluids	5
Fault diagnosis	6
Engine preservation	7
Parts and service	8
General data	9

General information	1
Introduction	1.02
How to care for your engine	1.03
Engine identification	1.04
Perkins companies	1.05
Safety precautions	1.06
Engine lift equipment	1.07

1 GENERAL INFORMATION

Introduction

The 903.27 is a naturally aspirated diesel engine and is a development from Perkins Engines Limited, a world leader in the design and manufacture of high performance diesel engines.

More than sixty years of diesel production experience, together with the latest technology, have been applied to the manufacture of your engine to give you reliable and economic power.

Danger is indicated in the text by two methods:

Warning! This indicates that there is a possible danger to the person.

Caution: This indicates that there is a possible danger to the engine.

Note: Is used where the information is important, but there is not a danger.

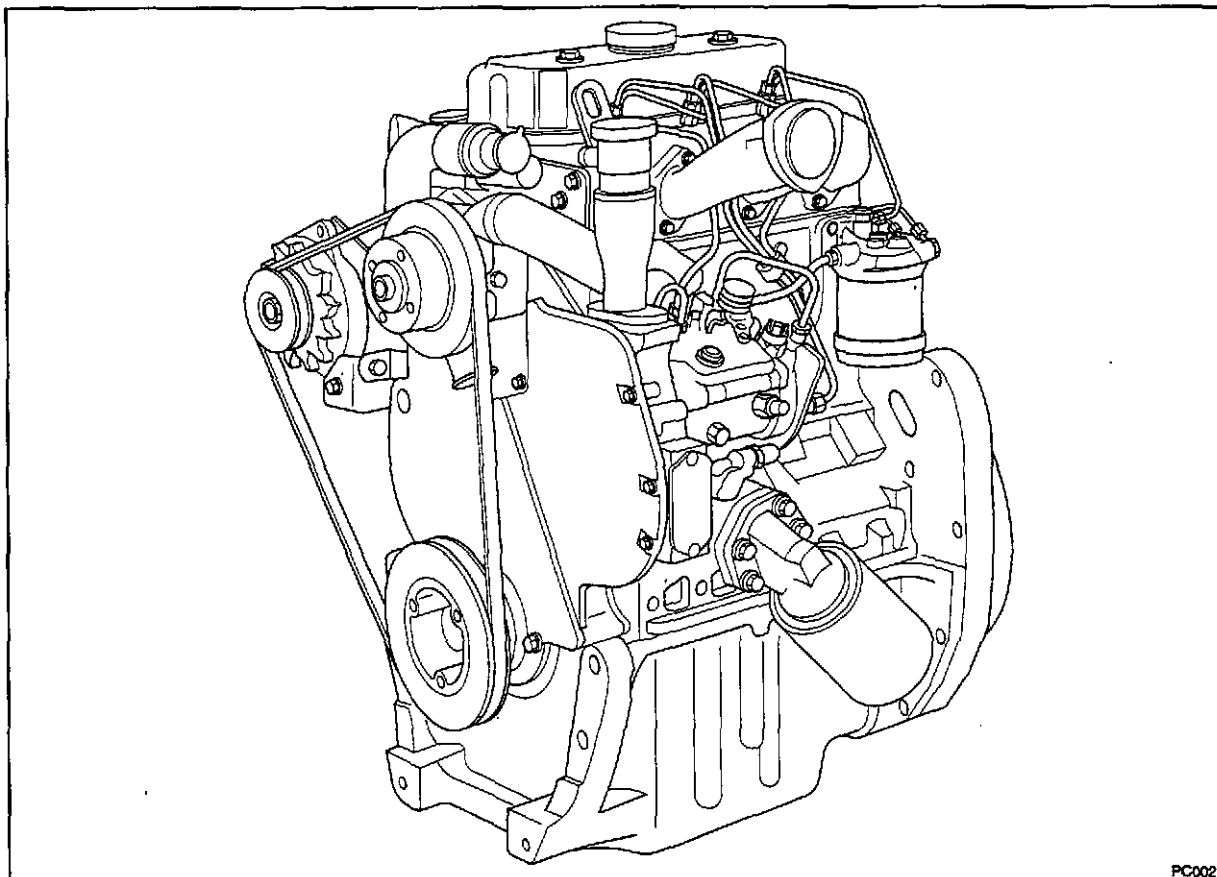

PC002

How to care for your engine

This handbook has been written to assist you to maintain and operate your engine correctly.

To obtain the best performance and the longest life from your engine, you must ensure that the maintenance operations are done at the intervals indicated in "Preventive maintenance". If the engine works in a very dusty environment or other adverse conditions, certain maintenance intervals will have to be reduced. Renew the filter canisters and lubricating oil regularly in order to ensure that the inside of your engine remains clean.

Ensure that all adjustments and repairs are done by personnel who have had the correct training. Perkins distributors have this type of personnel available. You can also obtain parts and service from your Perkins distributor. If you do not know the address of your nearest distributor, enquire at one of the Perkins companies listed on page 1.05.

The terms "left side" and "right side" apply when the engine is seen from the flywheel end.

Warning! Read the "Safety precautions" and remember them. They are given for your protection and must be applied at all times.

1 GENERAL INFORMATION

Engine identification

The 903.27 (engine code CP) is a naturally aspirated, direct injection, diesel engine.

The engine number is stamped on the left side of the cylinder block (A1). An example of an engine number is **CP80634 U300012Y**.

If you need parts, service or information for your engine, you must give the complete engine number to your Perkins distributor. If there is a number in the area of the label, marked TPL No. (A2), then this number must also be given to your Perkins distributor.

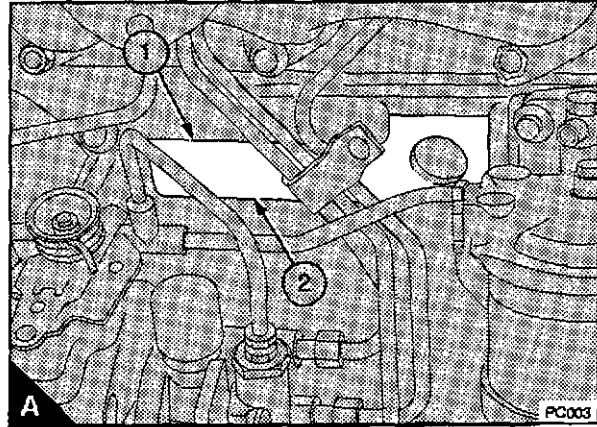

Perkins companies**Australia**

Perkins Engines Australia Pty. Ltd.,
Suite 2, 364 Main Street,
Mornington 3931, Victoria, Australia.
Telephone: (61) (59) 75 1877
Telex: Perkoil AA30816
Fax: (61) (59) 75 1305

France

Moteurs Perkins S.A.,
9-11 Avenue Michelet,
93583 Saint Ouen, Cedex, France.
Telephone: (33) (1) 40 10 42 71
Telex: 642924F
Fax: (33) (1) 40 10 42 45

Germany

Perkins Motoren GmbH,
Saalaeckerstrasse 4,
63801 Kleinostheim,
Germany.
Telephone: (49) (6027) 5010
Telex: 4188869A PER D
Fax: (49) (6027) 501130

Italy

Motori Perkins S.p.A.,
Via Socrate 8,
22070 Casnate con Bernate (Como), Italy.
Telephone: (39) (31) 564633 or 564625
Telex: 380658 Perkit I
Fax: (39) 31 249092 or 564145

Japan

Varity (Japan) K.K.,
Reinanzaka Building, 5th Floor,
14-2 Akasaka, 1-chome, Minato-ku,
Tokyo 107, Japan.
Telephone: (81) (03) 586 7377
Telex: Perkoil J2424823
Fax: (81) (03) 582 1596

Singapore

Perkins Engines Far East Ltd,
Care of:
39 Tuas Avenue 13,
Singapore 2263.
Telephone: 00658611318
Fax: 00658616252

United Kingdom

Perkins International Limited,
Eastfield, Peterborough PE1 5NA,
England.
Telephone: (44) (01733) 67474
Telex: 32501 Perken G
Fax: (44) (0733) 582240

United States of America

Detroit Diesel Corporation
13400 Outer Drive West,
Detroit, Michigan, 48239-4001
USA
Telephone: (1) (313) 592 5000
Telex: 4230091
Fax: (1) (313) 592 7288

Perkins Engines Latin America Inc.,
Suite 620,
999, Ponce de Leon Boulevard,
Coral Gables,
Florida 33134, U.S.A..
Telephone: (1) (305) 442 7413
Telex: 32501 Perken G
Fax: (1) (305) 442 7419

In addition to the above companies, there are Perkins distributors in most countries. Perkins International Ltd., Peterborough or one of the above companies can provide details.

1 GENERAL INFORMATION

Safety precautions

These safety precautions are important. You must refer also to the local regulations in the country of use. Some items only refer to specific applications.

- Only use these engines in the type of application for which they have been designed.
- Do not change the specification of the engine.
- Do not smoke when you put fuel in the tank.
- Clean away fuel which has been spilt. Material which has been contaminated by fuel must be moved to a safe place.
- Do not put fuel in the tank while the engine runs (unless it is absolutely necessary).
- Do not clean, add lubricating oil, or adjust the engine while it runs (unless you have had the correct training; even then extreme care must be used to prevent injury).
- Do not make adjustments that you do not understand.
- Ensure that the engine does not run in a location where it can cause a concentration of toxic emissions.
- Other persons must be kept at a safe distance while the engine or auxiliary equipment is in operation.
- Do not permit loose clothing or long hair near moving parts.
- Keep away from moving parts during engine operation. **Warning! Some moving parts cannot be seen clearly while the engine runs.**
- Do not operate the engine if a safety guard has been removed.
- Do not remove the filler cap of the cooling system while the engine is hot and while the coolant is under pressure, because dangerous hot coolant can be discharged.
- Do not allow sparks or fire near the batteries (especially when the batteries are on charge) because the gases from the electrolyte are highly flammable. The battery fluid is dangerous to the skin and especially to the eyes.
- Disconnect the battery terminals before a repair is made to the electrical system.
- Only one person must control the engine.
- Ensure that the engine is operated only from the control panel or from the operators position.
- If your skin comes into contact with high-pressure fuel, obtain medical assistance immediately.
- Diesel fuel and lubricating oil (especially used lubricating oil) can damage the skin of certain persons. Protect your hands with gloves or a special solution to protect the skin.
- Do not wear clothing which is contaminated by lubricating oil. Do not put material which is contaminated with oil into the pockets of clothing.
- Discard used lubricating oil in a safe place to prevent contamination.
- Ensure that the control lever of the transmission drive is in the "out-of-drive" position before the engine is started.
- Use extreme care if emergency repairs must be made in adverse conditions.
- The combustible material of some components of the engine (for example certain seals) can become extremely dangerous if it is burned. Never allow this burnt material to come into contact with the skin or with the eyes.
- Read and use the instructions relevant to lift equipment which are given on page 1.07.
- Always use a safety cage to protect the operator when a component is to be pressure tested in a bath of water. Fit safety wires to secure the plugs which seal the hose connections of a component which is to be pressure tested.
- Do not allow compressed air to contact your skin. If compressed air enters your skin, obtain medical help immediately.
- Fit only genuine Perkins parts.

Engine lift equipment

The weight of the engine, when it is fitted with the following components, is 305 kg (672 lb) (1):

Inlet and exhaust manifolds
 Water and fuel pumps
 Oil and fuel filters
 Alternator and starter motor
 Flywheel and flywheel housing

(1) Does not include coolant, lubricant or gearbox.

Note: The weight of an engine will vary depending on the final specification.

It is recommended that lift equipment with a S.W.L. (safe working limit) of 400 kg (882 lb) minimum capacity is to be used.

Before the engine is lifted:

- Always use engine lift equipment of the approved type and of the correct capacity to lift the engine. It is recommended that lift equipment of the type shown in (A) is used, to provide a vertical lift directly above the engine lift brackets (A1). Never use a single lift bracket to raise an engine.
- Check the engine lift brackets for damage and that they are secure before the engine is lifted. The torque for the setscrews for the engine lift brackets is 44 Nm (33 lbf ft) 4,5 kgf m.
- To avoid damage to the rocker cover, ensure that there is clearance between the hooks and the rocker cover.
- Use lift equipment or obtain assistance to lift heavy engine components such as the cylinder block, cylinder head, flywheel housing, crankshaft and flywheel.

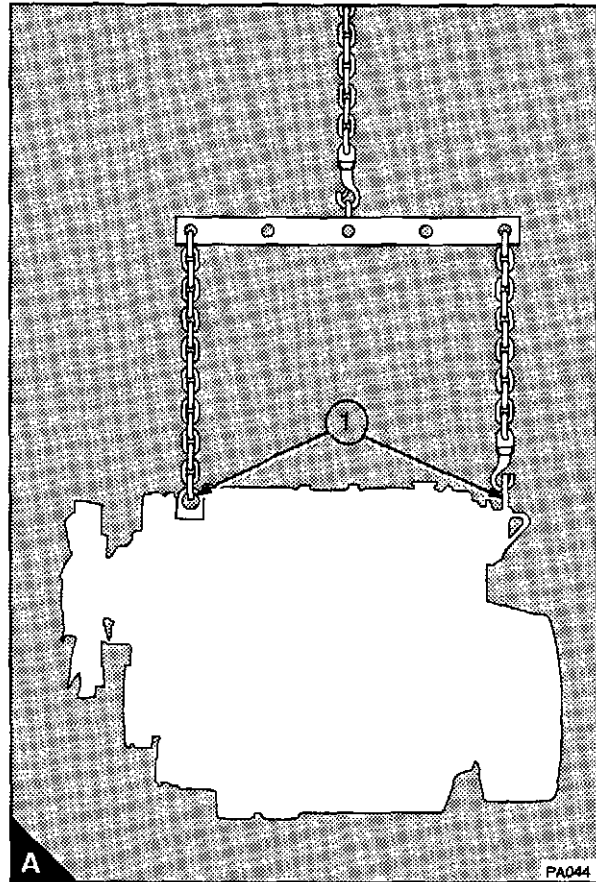

Engine views	2
Introduction	2.02
Location of engine parts	2.02

2 ENGINE VIEWS

Introduction

Perkins engines are built for specific applications and the views which follow do not necessarily match your engine specification.

Location of engine parts

Front and left side view

- 1 Atomiser
- 2 Leak-off pipe for atomisers
- 3 Exhaust manifold
- 4 Fuel filter
- 5 Drain plug for coolant
- 6 Fuel injection pump
- 7 Lubricating oil filter
- 8 Crankshaft pulley
- 9 Breather assembly
- 10 Coolant inlet
- 11 Coolant pump
- 12 Coolant outlet
- 13 Thermostat housing
- 14 Front lift bracket
- 15 Filler cap for lubricating oil

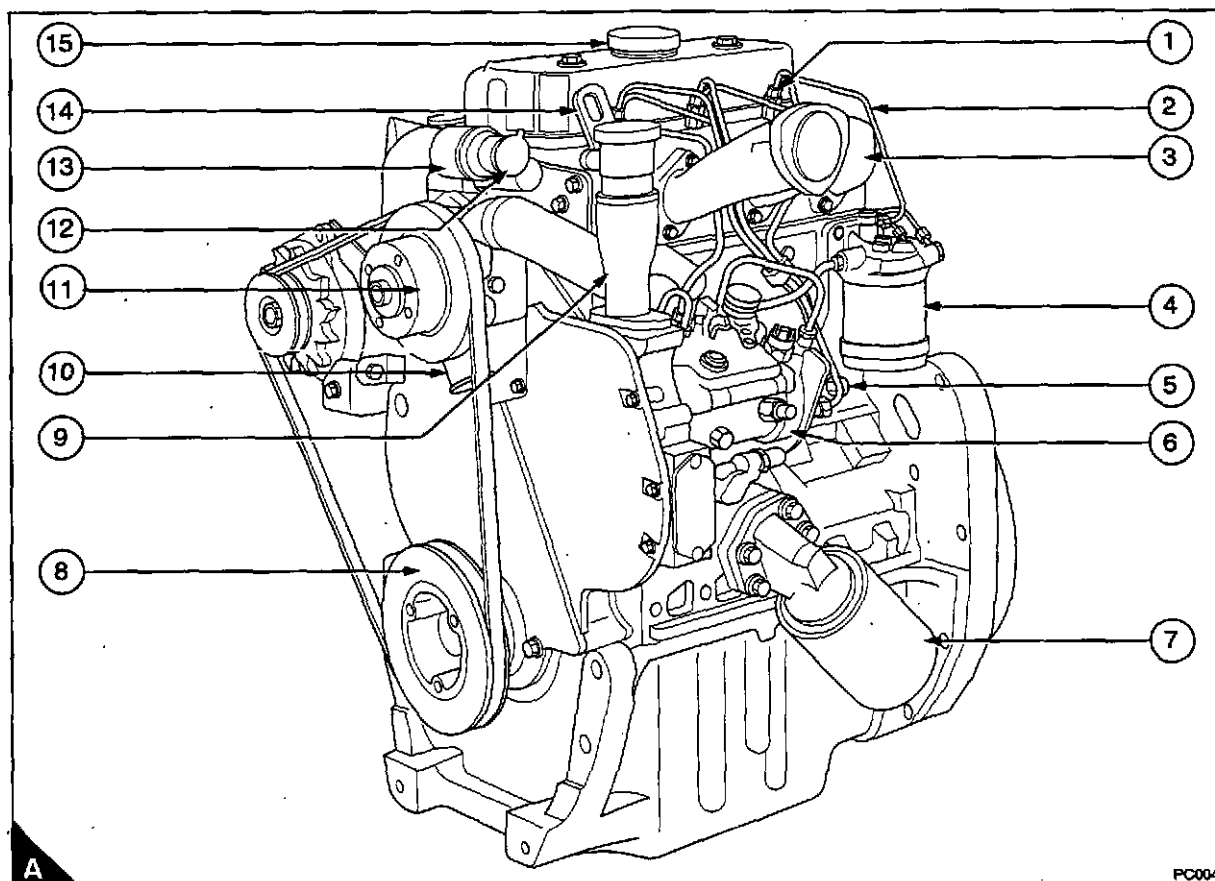

Location of engine parts**Rear and right side view**

- 16 Fuelled starting aid
- 17 Induction manifold
- 18 Dipstick for engine lubricating oil
- 19 Alternator
- 20 Drive belt for coolant pump, fan and alternator
- 21 Sump for engine lubricating oil
- 22 Drain plug for engine lubricating oil
- 23 Flywheel housing
- 24 Flywheel
- 25 Starter motor
- 26 Fuel lift pump
- 27 Rear lift bracket
- 28 Rocker cover

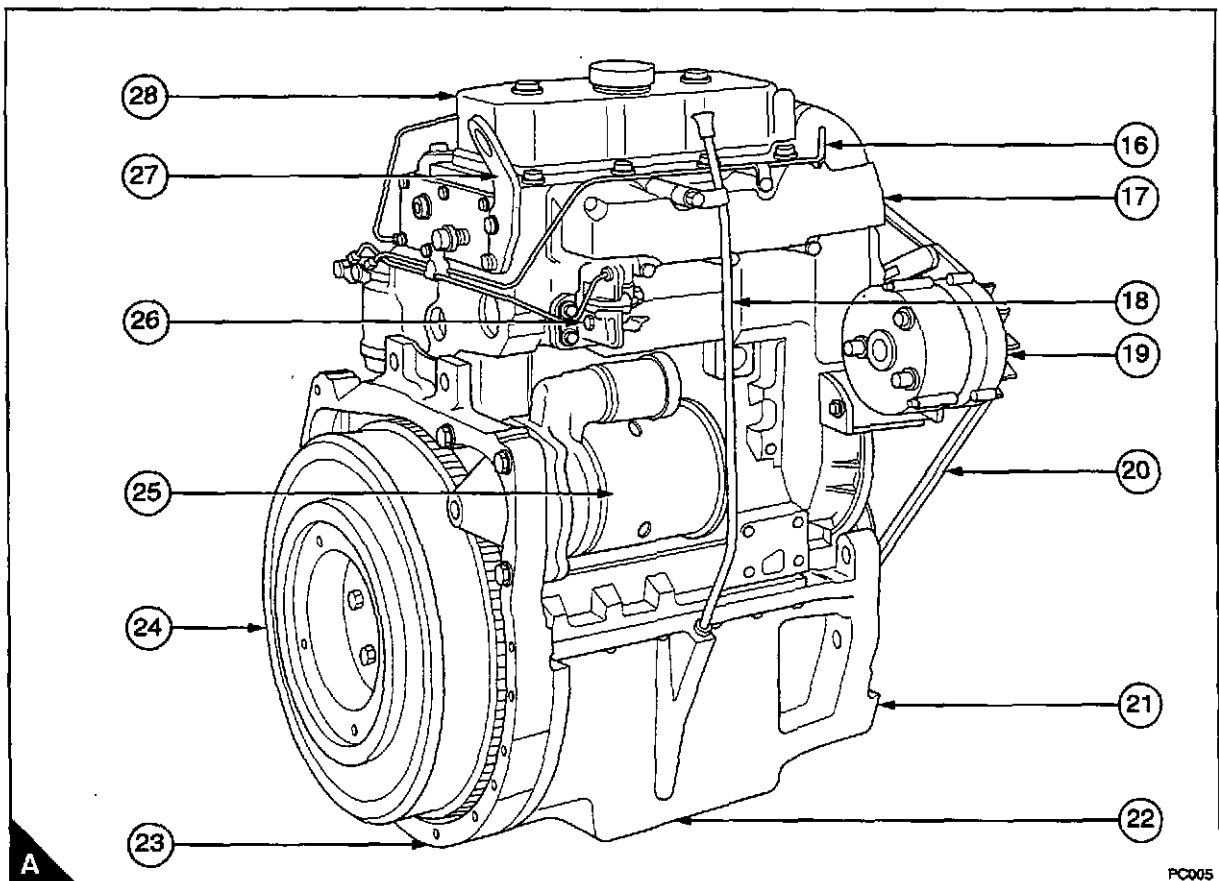

Operation instructions	3
How to start the engine	3.02
How to stop the engine	3.04
Adjustment of engine speed range	3.04
Engine operation at idle speed	3.04
Running-in	3.04
Altitude	3.04

3 OPERATION INSTRUCTIONS

How to start the engine

Caution: *Ether must not be used as a cold start aid for these engines. If Ether is used, the engine could be damaged.*

Several factors affect engine start, for example:

- The power of the batteries
- The performance of the starter motor
- The viscosity of the lubricating oil
- The installation of a cold start system

Diesel engines need a cold starting aid if they are to start in very cold conditions. Normally, your vehicle or your machine will be fitted with the correct equipment for your region of operation.

Before the engine is started:

- The operator should understand fully the reason for the controls and their use.
- Check that there is sufficient coolant and if necessary, add the correct coolant. See section 4 of this handbook.
- Check that there is sufficient lubricating oil in the sump and if necessary, add lubricating oil. See section 4 of this handbook. Ensure that the lubricating oil is of the correct grade for the ambient conditions.
- Fill the fuel tank with fuel of the correct specification.
- Check the air filter and its connections.

Caution: *If the engine is fitted with a closed breather system, ensure that the breather pipe and hose clips are fitted correctly.*

- Ensure that all of the electrical connections are tight.

Notes:

- See section 5 of this handbook for the correct engine fluids.
- The procedures to start the engine may vary according to the application. If possible, consult the User's Handbook for the application.

Caution: *If the engine has not run for several weeks, see "Caution" on page 7.02. These engines can be equipped with one of two types of cold starting aid.*

Perkins engines can be equipped with various cold start systems. These engines can be equipped with either a port heater or a fuelled starting aid.

Port heaters

These electrical devices are fitted in the induction manifold and heat the induction air. They are operated automatically when the starter motor is engaged.

Fuelled starting aid

An electrically operated device which ignites a specific amount of diesel fuel in the induction manifold in order to heat the induction air.

How to start a cold engine without starting aids

- 1 If the engine is equipped with a manual stop control, ensure that it is in the "run" position.
- 2 Adjust the engine speed control to the maximum speed position.
- 3 Turn the start key to the "S" position (A) to engage the starter motor. Allow the key to return to the "R" position, when the engine starts. Then adjust the engine speed control to get an even idle speed.
- 4 If the engine does not start within 30 seconds, allow the key to return to the "R" position for 30 seconds and then repeat paragraph 3. If the engine does not start within 30 seconds, refer to the fault diagnosis, section 6.

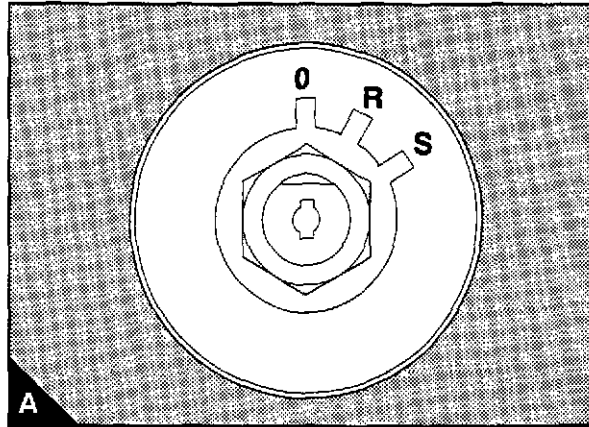

How to start a cold engine with the fuelled starting aid

- 1 If the engine is equipped with a manual stop control, ensure that it is in the "run" position.
- 2 Adjust the engine speed control to the maximum speed position.
- 3 Turn the start key to the "H" position (B) and keep it there for 20 seconds.
- 4 Turn the start key to the "HS" position in order to engage the starter motor. Allow the start key to return to the "R" position, when the engine starts. Then adjust the engine speed control to give an even idle speed.
- 5 If the engine does not start within 15 seconds, turn the start key to the "H" position and hold it there for 10 seconds and then repeat operation 4. If the engine does not start within 15 seconds, refer to the fault diagnosis table in section 6.

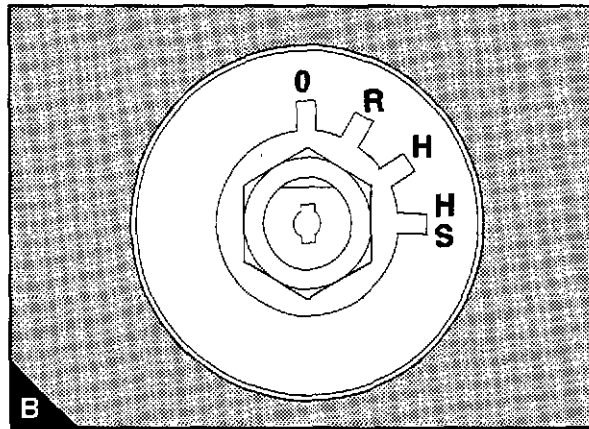

How to start a cold engine with the port heater

- 1 If the engine is equipped with a manual stop control, ensure that it is in the "run" position.
- 2 Adjust the engine speed control to the maximum speed position.
- 3 Turn the start key to the "H" position (B) and keep it there for 20 seconds.
- 4 Turn the start key to the "HS" position in order to engage the starter motor. Allow the start key to return to the "R" position, when the engine starts. Then adjust the engine speed control to give an even idle speed.
- 5 If the engine does not start within 15 seconds, turn the start key to the "H" position and hold it there for 10 seconds and then repeat operation 4. If the engine does not start within 15 seconds, refer to fault diagnosis, section 6.

How to start a warm engine

- 1 If the engine is equipped with a manual stop control, ensure that it is in the "run" position.
- 2 Adjust the engine speed control to the minimum speed position.
- 3 Turn the start key to the "HS" position (A) to engage the starter motor.
- 4 Allow the start key to return to the "R" position, when the engine starts.

Caution: Always ensure that the engine and starter motor are stationary before the starter motor is engaged again.

3 OPERATION INSTRUCTIONS

How to stop the engine

According to the equipment fitted, either turn the engine start key to the "O" position (3.03/A or B), or operate the manual stop control. If a manual stop control is used, ensure that the control returns to the "run" position after the engine has stopped. Also ensure that the engine start key is turned to the "O" position.

distributor or by an approved distributor for the fuel injection pump.

Adjustment of engine speed range

The idle or maximum speed settings must not be changed by the engine operator because this can damage the engine or the transmission. The warranty of the engine can be affected if the seals on the fuel injection pump are broken during the warranty period by a person who is not approved by Perkins.

Engine operation at idle speed

Do not operate the engine for long periods at idle speed as this could have an adverse affect on the engine performance or damage the engine.

Running-in

A gradual running-in of a new engine is not necessary. Prolonged operation at light load during the early life of the engine can cause lubricating oil to enter the exhaust system. Maximum load can be applied to a new engine as soon as the engine is put into service and the coolant temperature has reached a minimum of 60° C (140° F). The engine will benefit if the load is applied as soon as possible after the engine has been put into service.

Cautions:

- *Do not operate the engine at high speeds without a load.*
- *Do not overload the engine.*

Altitude

If the engine is to run at an altitude above 600 m (2,000 ft), the fuel delivery can be changed to reduce fuel consumption and smoke. Perkins can give the percentage of fuel reduction necessary if details of engine application and ambient conditions are given. Changes to the settings of the fuel injection pump must be made by a Perkins

Preventive maintenance	4
Preventive maintenance periods	4.02
Schedules	4.03
How to drain the cooling system	4.04
How to fill the cooling system	4.05
How to check the tension of the drive belt	4.06
How to adjust the tension the drive belt	4.06
Fuel Pre-filter	4.07
How to renew the element of the fuel filter	4.07
Atomiser fault	4.08
How to renew an atomiser	4.08
How to eliminate air from the fuel system	4.09
How to renew the lubricating oil	4.10
How to renew the canister of the lubricating oil filter	4.11
How to renew the engine breather valve (closed system)	4.12
Air filter	4.13
Restriction indicator	4.14
How to set the valve tip clearances	4.15

4 PREVENTIVE MAINTENANCE

Preventive maintenance periods

These preventive maintenance periods apply to average conditions of operation. Check the periods given by the manufacturer of the equipment in which the engine is installed. If necessary, use the shorter periods. When the operation of the engine must conform to the local regulations these periods and procedures may need to be adapted to ensure correct operation of the engine.

It is good preventive maintenance to check for leakage and loose fasteners at each service.

These maintenance periods apply only to engines that are operated with fuel and lubricating oil which conform to the specifications given in this handbook.

Schedules

The schedules which follow must be applied at the interval (hours or months) which occur first.

- A First service at 25/50 hours
- B Every day or every 8 hours
- C Every 250 hours or 6 months
- D Every 500 hours or 12 months
- E Every 1000 hours
- F Every 2000 hours
- G Every 5000 hours

A	B	C	D	E	F	G	Operation
•	•						Check the amount of coolant
		•					Check the concentration of the coolant (1)
		•					Check the drive belt of the alternator
•	•						Drain water from the fuel pre-filter
			•				Renew the element of the fuel filter
				•			Ensure that the atomisers are checked (3)
•							Ensure idle speed is checked and adjusted, if necessary (3)
	•						Check the amount of lubricating oil in the sump
•	•						Check the lubricating oil pressure at the gauge (2)
•			•				Renew the engine lubricating oil (4)
•			•				Renew the canister of the lubricating oil filter
						•	Renew the engine breather valve
							Clean the air cleaner or empty the dust bowl of the air filter
•	•						- extremely dusty conditions
		•					- normal conditions
			•				Clean or renew the air filter element, if this has not been indicated earlier
			•				Check all engine mounts
			•				Check all hoses and connections (also includes breather pipe)
				•			Ensure that the valve tip clearances of the engine are checked and, if necessary, adjusted (3)
			•				Check all electrical cables and connections (5)
					•		Ensure that the alternator and the starter motor are checked (3)

(1) Renew the antifreeze every 2 years. If a coolant inhibitor is used instead of antifreeze, it should be renewed every 6 months.

(2) If there is one fitted.

(3) By a person who has had the correct training.

(4) The oil change interval will change with the amount of sulphur in the fuel (see the table below and the Fuel Specification in section 5). The interval to change the canister of the lubricating oil filter is not affected.

(5) **Caution:** If there is a failure in the electrical circuit for the cold start advance, the engine will run continuously with the timing in the fully advanced position and serious damage to the engine will occur.

Percentage of Sulphur in the fuel	Oil change interval
<0,5	Normal
0,5-1,0	0.75 of normal
1,0>	0.5 of normal

4 PREVENTIVE MAINTENANCE

How to drain the cooling system

Warning! Do not drain the coolant while the engine is still hot and the system is under pressure because dangerous hot coolant can be discharged.

- 1 Ensure that the machine is on level ground.
- 2 Remove the filler cap of the cooling system.
- 3 Remove the drain plug (A1) from the side of the cylinder block in order to drain the engine. Ensure that the drain hole is not restricted.
- 4 Open the tap or remove the drain plug at the bottom of the radiator in order to drain the radiator. If the radiator does not have a tap or drain plug, disconnect the hose at the bottom of the radiator.
- 5 Flush the system with POWERPART Easy Flush.
- 6 Fit the drain plugs and the filler cap. Close the radiator tap or connect the radiator hose.

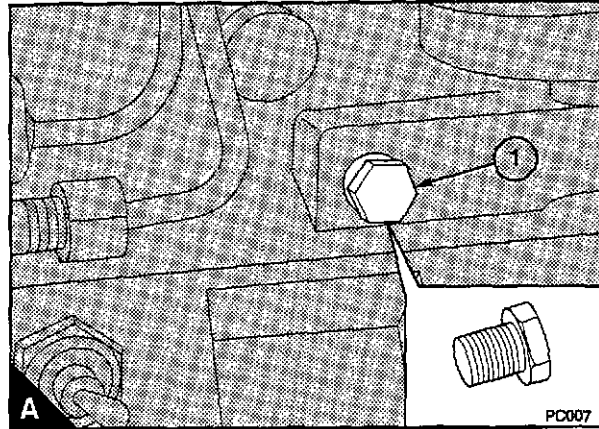

How to fill the cooling system

Warning! Do not remove the filler cap of the cooling system while the engine is still hot and the system is under pressure because dangerous hot coolant can be discharged.

Caution: See "Coolant specification" in section 5 for details of the correct coolant to be used in the cooling system. If coolant is to be added to the system during service, it must consist of the same original mixture as used to fill the system. The engine must be allowed to cool before coolant is added.

- 1 Remove the filler cap of the cooling system.
 - 2 In order to eliminate air from the system, the coolant must be added very slowly.
 - 3 Fill the cooling system until coolant reaches the bottom of the filler tube.
 - 4 If the thermostat assembly is fitted horizontally as shown in (A), release by two turns, the vent screw (A1) on top of the thermostat assembly.
 - 5 When coolant, free from air flows from the vent point, tighten the vent screw.
- Note:** If the thermostat assembly is fitted vertically, it will not be necessary to release the vent screw to eliminate air from the thermostat assembly.
- 6 If necessary, add coolant until the level of the coolant reaches the bottom of the filler tube. Fit the filler cap.
 - 7 Start the engine. Allow the engine to operate at a fast idle until the engine reaches its normal temperature of operation. Stop the engine and allow it to cool.
 - 8 Remove carefully, the filler cap and add coolant until the level of the coolant reaches the bottom of the filler tube. Fit the filler cap.
 - 9 Repeat paragraphs 4, 5 and 6.

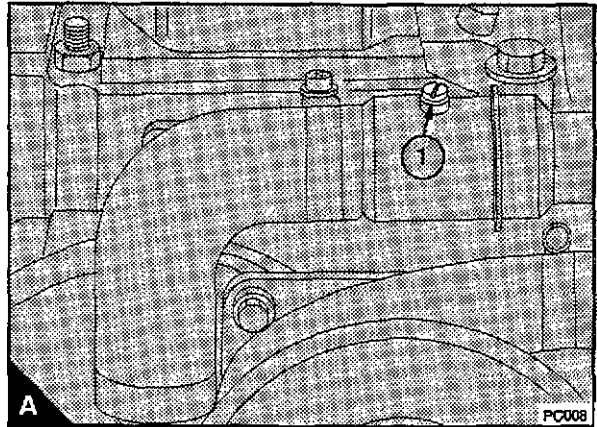

4 PREVENTIVE MAINTENANCE

How to check the tension of the drive belt

Renew a belt if it is worn or damaged.

The condition of the belt should be checked at the intervals shown on page 4.03. The belt should be renewed if there are cracks in the belt or if the belt is contaminated by oil or grease.

To check the deflection, press down the belt with the thumb at the centre of the longest free length and check the deflection (A). With moderate thumb pressure 45 N (10 lbf) 4,5 kgf the correct deflection of the belt is 10 mm (3/8 in).

How to adjust the tension of the drive belt

- 1 Loosen the pivot fasteners of the alternator (A2) and the adjustment link fasteners (A1).
- 2 Change the position of the alternator to give the correct tension. Tighten the pivot fasteners of the alternator and the adjustment link fasteners.
- 3 Check the belt tension again to ensure that it is still correct.

Note: If a new belt is fitted, the belt tension must be checked again after the first 25 hours of operation.

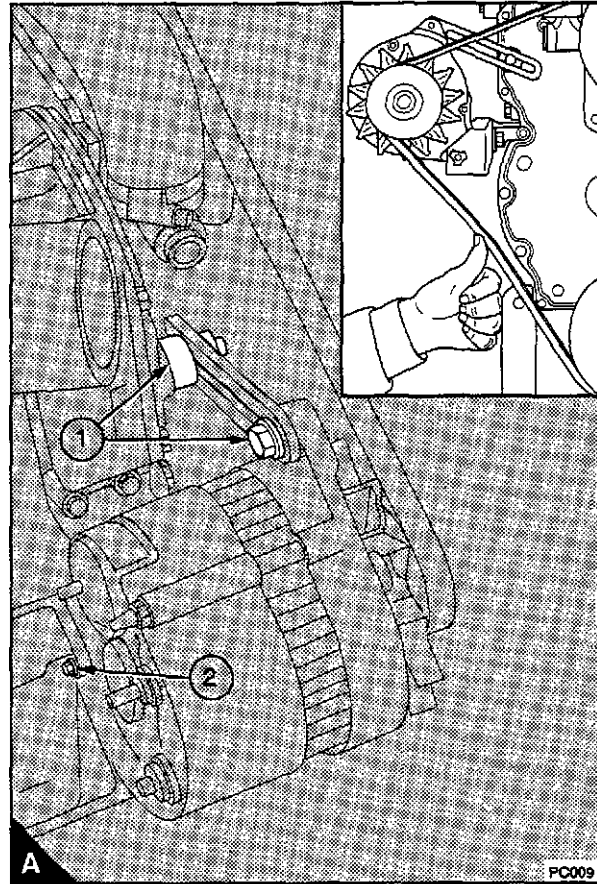

Fuel pre-filter

This will normally be fitted between the fuel tank and the engine. Check the filter bowl for water at regular intervals and drain as necessary.

How to renew the element of the fuel filter

- 1 Clean the outside surfaces of the fuel filter assembly. If a drain tap is fitted to the filter bowl, drain the fuel from the filter.
- 2 Hold the bottom cover of the filter element and release the setscrew (A1) which is fitted through the filter head above the centre of the element.
- 3 Lower the bottom cover of the filter (A6).
- 4 Remove the element (A4) and discard it.

Warning: Discard the used canister and fuel oil in a safe place and in accordance with local regulations.

- 5 Clean the inside surfaces of the filter head and the cover.
- 6 Renew the seals (A3 and A5) and the 'O' ring (A2) and lightly lubricate them with clean fuel. The larger seal is fitted to the filter head and the smaller seal is fitted to the bottom cover.
- 7 Put the bottom cover under the new element and hold the element squarely to the filter head. Ensure that the element is fitted in the centre against the 'O' ring in the filter head. With the assembly in this position, engage and tighten the setscrew.

Eliminate the air from the fuel filter (see page 4.09).

Caution: It is important that only the genuine Perkins parts are used. The use of wrong parts could damage the fuel injection pump.

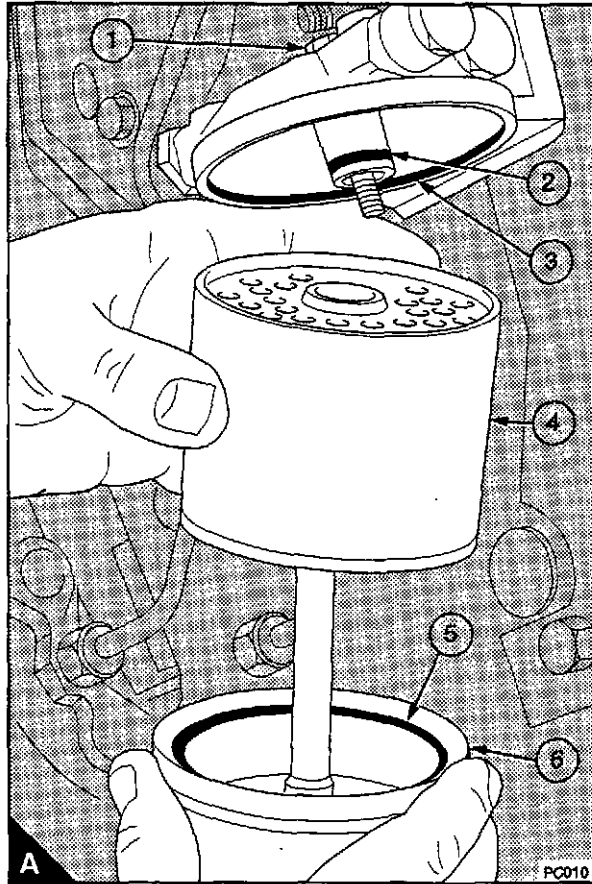

4 PREVENTIVE MAINTENANCE

Atomiser fault

Warnings!

- If your skin comes into contact with high-pressure fuel, obtain medical assistance immediately.
- Keep away from moving parts during engine operation. Some moving parts cannot be seen clearly while the engine runs.

An atomiser fault can cause an engine misfire.

In order to find which atomiser is defective, operate the engine at a fast idle speed. Loosen and tighten the union nut of the high-pressure fuel pipe at each atomiser. When the union nut of the defective atomiser is loosened, it has little or no effect on the engine speed.

How to renew an atomiser

Caution: Do not allow dirt to enter the fuel system. Before a connection is disconnected, clean thoroughly the area around the connection. After a component has been disconnected, fit a suitable cover to all open connections.

- 1 Remove the fuel leak-off pipe.
- 2 Remove the union nuts of the high-pressure pipe from the atomiser and from the fuel injection pump. Do not bend the pipe. If necessary, remove the pipe clamps.
- 3 Release the clamp setscrew (A1) of the atomiser. Remove the clamp (A3). Remove the atomiser (A5) and its seat washer (A6).
- 4 Check the clamp for damage and, if necessary, renew the clamp. Renew the atomiser seat washer and the dust seal (A4).
- 5 Put the new atomiser and seat washer into position with the leak-off connection (A2) towards the rear of the engine. Ensure that the atomiser is not tilted and fit the clamp with the arms of the clamp fitted squarely on the shoulders of the atomiser. Tighten the clamp setscrew to 22 Nm (16 lbf ft) 2,2 kgf m.

Caution: Do not tighten the union nuts of the high-pressure pipes more than the recommended torque tension. If there is a leakage from the union nut, ensure that the pipe is correctly aligned with the atomiser inlet. Do not tighten the atomiser union nut more, as this can cause a restriction at the end of the pipe. This can affect the fuel delivery.

- 6 Fit the high-pressure fuel pipe and tighten the union nuts to 22,5 Nm (16.5 lbf ft) 2,3 kgf m. If necessary, fit the pipe clamps.

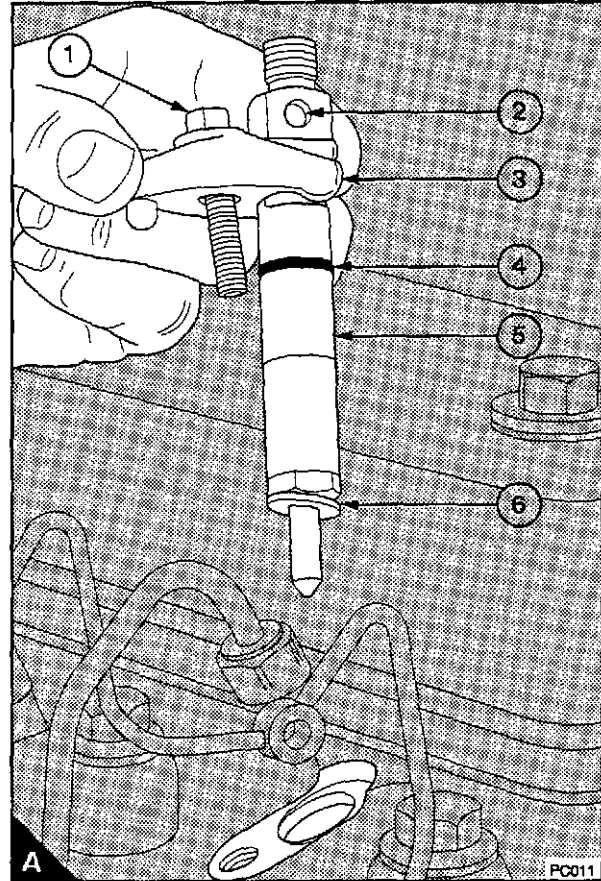

- 7 Renew the sealing washers and fit the leak-off pipe. Tighten the banjo bolt to 9,5 Nm (7,0 lbf ft) 1,0 kgf m.

- 8 Operate the engine and check for leakage of fuel and air.

How to eliminate air from the fuel system

If air enters the fuel system, it must be eliminated before the engine can be started.

Air can enter the system if:

- The fuel tank is drained during normal operation.
- The low-pressure fuel pipes are disconnected.
- A part of the low-pressure fuel system leaks during engine operation.

The fuel injection pump has a self-vent feature, and air vent screws are not required. No connections or plugs need be released to eliminate air from the fuel system.

If the engine has been stopped by air in the fuel system:

- 1 Ensure that fuel has been added to the tank or that the leakage has been corrected.
- 2 If a manual stop control is fitted, ensure that it is in the "run" position.
- 3 Operate the starter motor until the engine starts.

Note: When the starter motor is operated, air will pass from the body of the fuel injection pump, through the vent pipe (A1) and into the fuel leak-off rail.

If the system or a component in the system has been drained, use the procedure below.

- 1 Turn the start key to the "R" position. If a manual stop control is fitted, ensure that it is in the "run" position.
- 2 Loosen the banjo connection bolt (A2) which is fitted on top of the filter.
- 3 Operate the lever (B1) of the fuel lift pump until fuel, free from air, flows from the banjo connection. If the drive cam for the fuel lift pump is at the point of maximum cam lift, it will not be possible to operate the priming lever. In this situation, the crankshaft must be rotated one revolution.
- 4 Loosen the union nut of the fuelled starting aid (if one is fitted) and operate the lever of the fuel lift pump until fuel, free from air, flows from the connection. Tighten the union nut at the fuelled starting aid.
- 5 Loosen the union nuts of the high-pressure fuel pipes at two of the atomisers. Operate the starter motor until fuel, free from air, comes from the pipe connections. Tighten the high-pressure pipe connections.
- 6 The engine is now ready to start

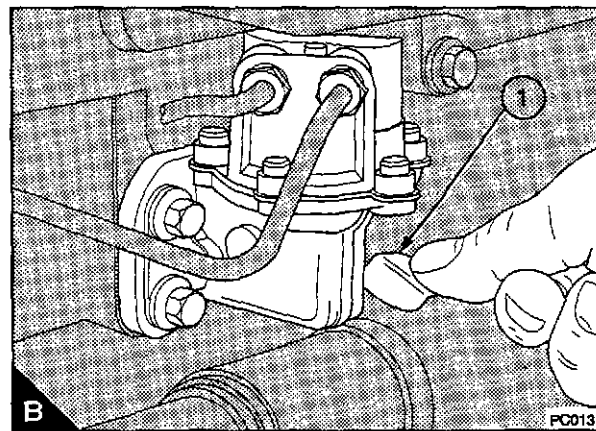
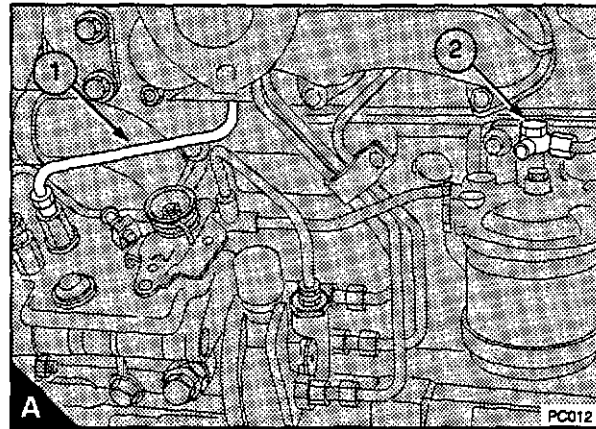

If the engine runs correctly for a short time and then stops or runs roughly, check for air in the fuel system. If there is air in the fuel system, there is probably a leakage in the low pressure system.

4 PREVENTIVE MAINTENANCE

How to renew the lubricating oil

Warning! Discard the used lubricating oil in a safe place and in accordance with local regulations.

Caution: Do not fill the sump past the "Max" mark on the dipstick.

- 1 Operate the engine until it is warm.
- 2 Stop the engine, remove the sump drain plug (A1) together with its "O" ring and drain the lubricating oil from the sump.
- 3 Ensure that the "O" ring is not damaged. Fit the drain plug together with its "O" ring and tighten the plug to 34 Nm (25 lb ft) 3,5 kgf m.

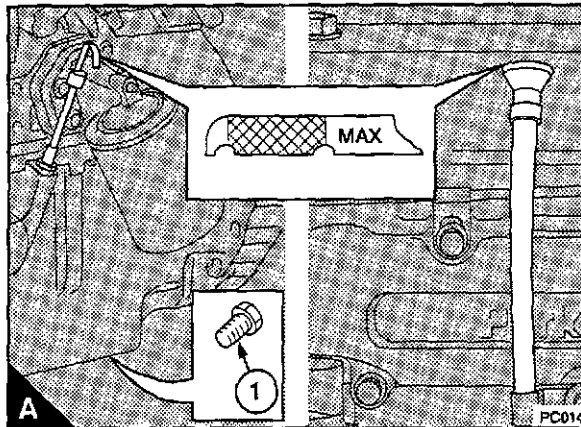

Notes:

- The dipstick may be fitted on the left hand or the right hand side of the engine in accordance with the application.
 - If the lubricating oil is put into the engine through the filler in the cylinder head cover, enough time should be allowed for the oil to reach the sump before the level is checked with the dipstick. If this is not done, too much oil could be added to the engine.
- 4 Fill the sump to the "MAX" mark on the dipstick (A) with new and clean lubricating oil of an approved grade, see page 5.03.
 - 5 Fit the dipstick and the filler cap.
 - 6 Start the engine and check for lubricating oil leakage at the drain plug. Stop the engine. After 15 minutes check the oil level on the dipstick and, if necessary, put more lubricating oil into the sump

How to renew the canister of the lubricating oil filter

Warning! Discard the used canister and lubricating oil in a safe place and in accordance with local regulations.

Cautions:

- Do not fill the sump past the "Max" mark on the dipstick.
- The canister contains a valve and special tube to ensure that lubricating oil does not drain from the filter. Therefore, ensure that the correct Perkins POWERPART canister is used.

- 1 Put a tray under the filter to retain spilt lubricating oil.
- 2 Use a strap wrench or similar tool to loosen the filter canister. Remove and discard the canister. Ensure that the adaptor (A1) is secure in the filter head.
- 3 Clean inside the filter head.
- 4 Add clean engine lubricating oil to the new canister. Allow the oil enough time to pass through the filter element.
- 5 Lubricate the seal (A2) on top of the canister with clean engine lubricating oil.
- 6 Fit the new canister and tighten it by hand until the seal contacts the filter head. Tighten the canister a further 1/2 to 3/4 of a turn by hand only. Do not use a strap wrench.
- 7 Ensure that there is lubricating oil in the sump. Ensure that the engine will not start and operate the starter motor until oil pressure is obtained. To ensure that the engine will not start, either put the manual stop control in the "stop" position or disconnect the electrical stop control of the fuel injection pump. Oil pressure is indicated when the warning light is extinguished or by a reading on the gauge.
- 8 Start the engine and check for leakage from the filter. Stop the engine. After 15 minutes check the oil level on the dipstick and, if necessary, put more lubricating oil into the sump.

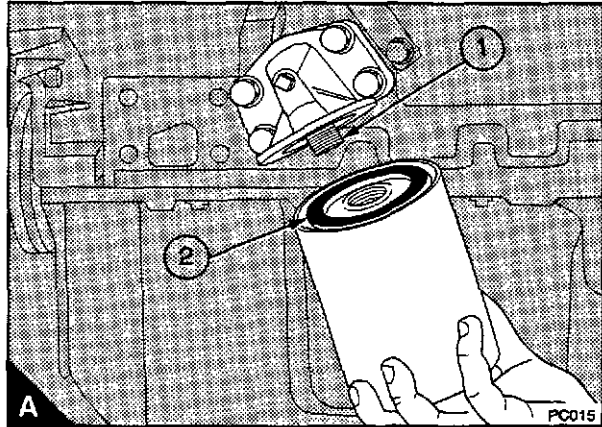

4 PREVENTIVE MAINTENANCE

How to renew the engine breather valve (closed system)

The engine breather assembly is fitted to the top left hand side of the timing case. It consists of two parts; the adaptor (A3) which is fitted to the timing case by two setscrews; and the breather valve (A2) which is fitted to the top of the adaptor. The breather is a sealed unit which contains a valve and a gauze filter. Crankcase gases pass through a flexible hose which is fitted between the connection (A5) and the pipe between the air filter and the induction manifold.

Cautions:

- It is important that the area around the vent hole (A1) is kept clean and the vent hole is not restricted.
- Ensure that the pipe, when fitted, does not contact other components as this may cause the pipe to fail.
- Do not add lubricating oil to the engine through the engine breather adaptor.

- 1 Release the clips which retain the engine breather pipe and remove the pipe from the connection (A5).
- 2 Pull the breather valve out from the adaptor.
- 3 Lubricate the 'O' rings (A4) on the new breather valve with clean engine oil and push the breather valve into the adaptor.
- 4 Fit the breather pipe and tighten the hose clips.

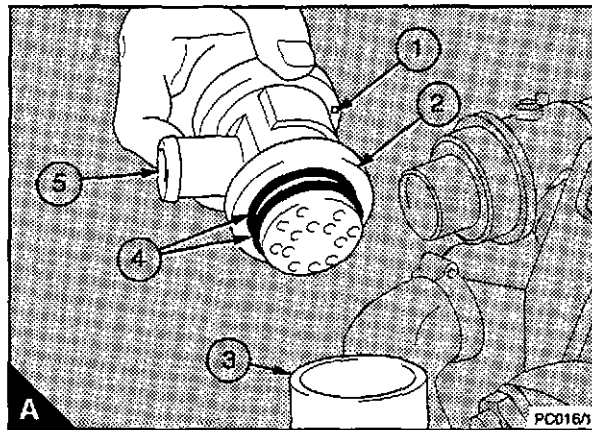

Air filter

Environmental conditions have an important effect on the frequency at which the air filter needs service.

Certain air filters have a separate dust bowl (A1) which must be cleaned at intervals. The amount of dust in the bowl shows if it has been removed at the correct time for the conditions of operation. Do not let dust completely fill the bowl, because this will reduce the life of the filter element (A2).

Certain air filters have automatic dust valves (B1) through which dust is expelled from the filter. The rubber dust valve must be kept clean. Ensure that the sides of the valves close completely together and that they can separate freely.

If a restriction indicator (4.14/A) is fitted, it will indicate precisely when the air filter element needs service. This prevents the premature removal of the filter element which causes extra cost or late removal of the element which can cause loss of engine power.

The filter element must be cleaned or renewed according to the manufacturer's recommendations

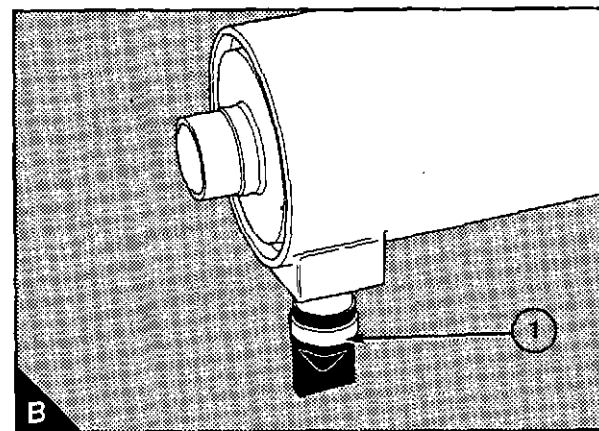
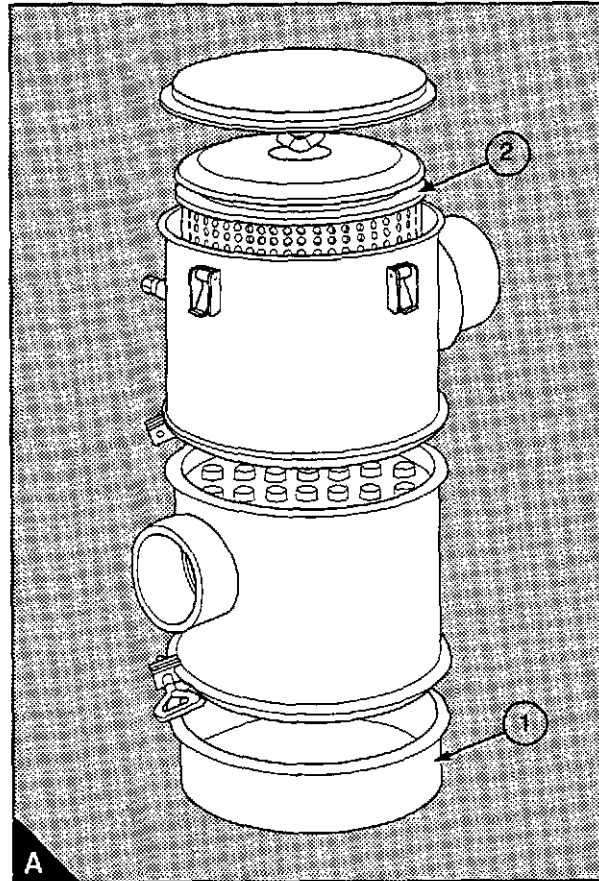

4 PREVENTIVE MAINTENANCE

Restriction indicator

The restriction indicator for these engines must work at a pressure difference of 381-457 mm (15-18 in) of water gauge. It is fitted on the air filter outlet or between the air filter and the induction manifold.

When the red warning indicator (A1) is seen through the clear panel (A2) after the engine has stopped, the air filter element must be removed for service.

After a clean element has been fitted, press the rubber bottom (A3) or the button (A4) of the restriction indicator to reset the red warning indicator.

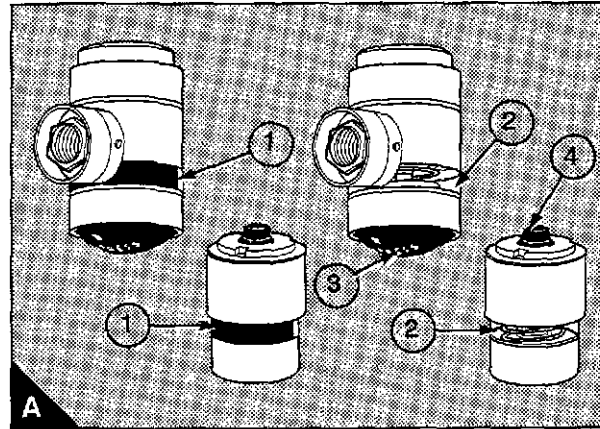

How to set the valve tip clearances

The valve tip clearance is checked with feeler gauges between the top of the valve stem and the rocker lever (A), with the engine hot or cold. The correct clearance is 0,20 mm (0.008 in) for the inlet valves and 0,45 mm (0.018 in) for the exhaust valves. The valve positions are shown at (B).

The sequence of the valves from number 1 cylinder is shown in the table below.

Note: Number 1 cylinder is at the front of the engine.

1 Rotate the crankshaft in the normal direction of rotation until the inlet valve of number 1 cylinder has just opened and the exhaust valve of the same cylinder has not closed completely. Check / adjust the clearance of valve number 3 and number 6 and adjust them, if necessary.

2 Set the valves of number 2 cylinder as indicated above for number 1 cylinder. Then check / adjust the clearance of valve number 2 and number 5.

3 Set the valves of number 3 cylinder. Then check / adjust the clearance of valve number 1 and number 4.

4 If necessary, fit a new seal to the rocker cover. Ensure that the seal is fitted correctly and fit the cover. Fit the nuts which retain the rocker cover and tighten them to:

Metal cover: 30 Nm (22 lbf ft) 3,6 kgf m

Plastic cover: 20 Nm (15 lbf ft) 2,0 kgf m.

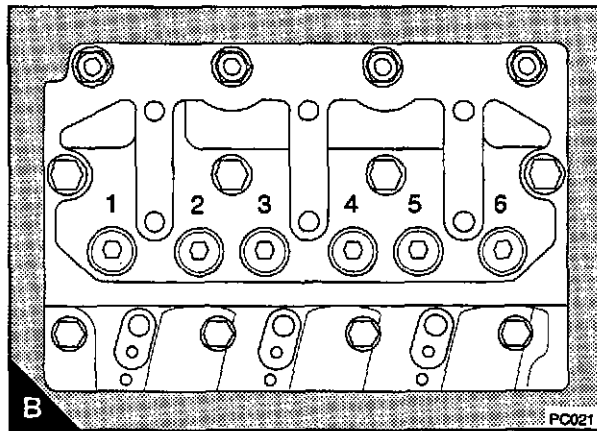
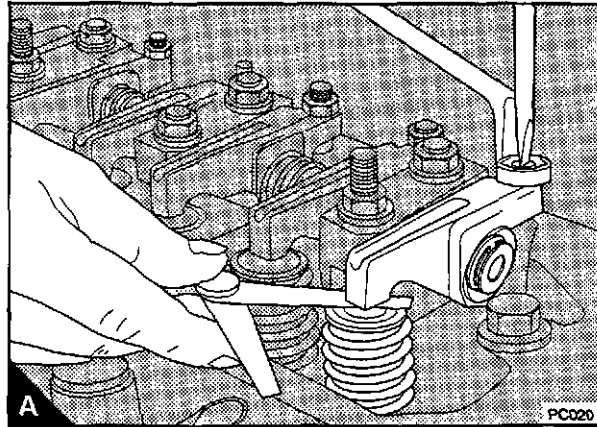

Cylinder number	1		2		3	
	1	2	3	4	5	6
Valve type	inlet	exhaust	inlet	exhaust	inlet	exhaust

Engine fluids	5
Fuel specification	5.02
Lubricating oil specification	5.03
Coolant specification	5.04

5 ENGINE FLUIDS

Fuel specification

To get the correct power and performance from your engine, use good quality fuel. The recommended fuel specification for Perkins engines is indicated below:

Cetane number	45 minimum
Viscosity	2.0/4.5 centistokes at 40°C
Density	0,835/0,855 kg/litre
Sulphur	0.2% of mass, maximum
Distillation	85% at 350°C

Cetane number: indicates ignition performance. A fuel with a low cetane number can cause cold start problems and affect combustion.

Viscosity is the resistance to flow and engine performance can be affected if it is outside the limits.

Density: A lower density reduces engine power, a higher density increases engine power and exhaust smoke.

Sulphur: A high sulphur content (not normally found in Europe, North America or Australasia) can cause engine wear. Where only high sulphur fuels are available, it is necessary to use a highly alkaline lubricating oil in the engine or to renew the lubricating oil more frequently see page 4.03.

Distillation: This is an indication of the mixture of different hydrocarbons in the fuel. A high ratio of light-weight hydrocarbons can affect the combustion characteristics.

Low temperature fuels

Special winter fuels may be available for engine operation at temperatures below 0°C. These fuels have a lower viscosity and also limit the wax formation in the fuel at low temperatures. If wax formation occurs, this could stop the fuel flow through the filter.

If you need advice on adjustments to an engine setting or to the lubricating oil change periods which may be necessary because of the standard of the available fuel, contact the service department of one of the Perkins Companies listed on page 1.05.

Lubricating oil specification

Use only a good quality lubricating oil which is not less than the specification API CC/SE.

API CD/SE or CCMC D4 can be used, but it is not recommended during the first 25 to 50 hours nor for light load applications.

Caution: The type of lubricating oil to be used may be affected by the quality of the fuel which is available. For further details see "Fuel specification" on page 5.02 and the preventative maintenance schedules on page 4.03.

Always ensure that the correct viscosity grade of lubricating oil is used for the ambient temperature range in which the engine will run as shown in the chart (A).

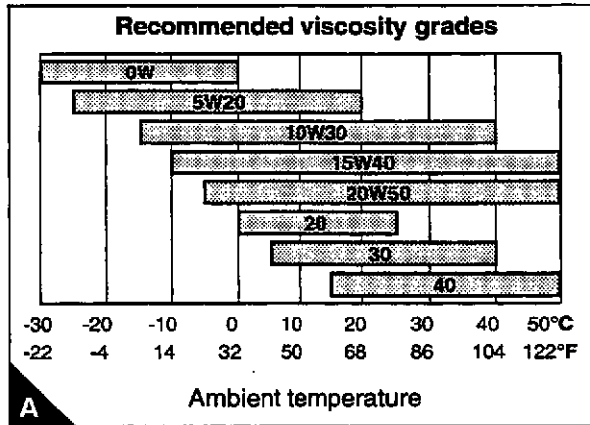

5 ENGINE FLUIDS

Coolant specification

The quality of the coolant which is used can have a great effect on the efficiency and life of the cooling system. The recommendations indicated below can help to maintain a good cooling system and to protect it against frost and/or corrosion.

If the correct procedures are not used, Perkins cannot be held responsible for frost or corrosion damage.

1 If it is possible, use clean soft water in the coolant.

2 If an antifreeze mixture, other than Perkins POWERPART, is used to prevent frost damage, it must have an ethanediol base (ethylene glycol) with a corrosion inhibitor. It is recommended that the corrosion inhibitor is of the sodium nitrite or sodium benzoate type. The antifreeze mixture must be an efficient coolant at all ambient temperatures and it must provide protection against corrosion. It must also have a specification at least as good as the requirements of either B.S.6580 or MOD AL39

Perkins POWERPART antifreeze exceeds the requirements of the above standard.

The quality of the antifreeze coolant must be checked at least once a year, for example, at the beginning of the cold period. The coolant must be renewed every two years.

The antifreeze mixture must consist of equal quantities of antifreeze and water. Concentrations of more than 50% of antifreeze must not be used because these can affect adversely the performance of the coolant.

3 When frost protection is not necessary, it is recommended to use an approved antifreeze mixture because this gives a protection against corrosion and also raises the boiling point of the coolant. If an approved antifreeze mixture is not available, add a correct mixture of corrosion inhibitor to the water.

Renew the mixture of water and corrosion inhibitor every six months or check it according to the inhibitor manufacturer's recommendations.

Caution: *Certain corrosion inhibitor mixtures could cause damage to some engine components. If there is doubt about the corrosion inhibitor to be used, contact the Service Department of one of the Perkins Companies listed on page 1.05.*

Fault diagnosis

6

Problems and possible causes	6.02
List of possible causes	6.03

6 FAULT DIAGNOSIS

Problems and possible causes

Problem	Possible causes	
	Checks by the user	Checks by the workshop personnel
The starter motor turns the engine too slowly	1, 2, 3, 4	
The engine does not start	5, 6, 7, 8, 9, 10, 12, 13, 14, 15, 17	34, 35, 36, 37, 38, 42, 43, 44
The engine is difficult to start	5, 7, 8, 9, 10, 11, 12, 13, 14, 15, 16, 17, 19	34, 36, 37, 38, 40, 42, 43, 44
Not enough power	8, 9, 10, 11, 12, 13, 16, 17, 18, 19, 20, 21	34, 36, 37, 38, 39, 42, 43, 44
Misfire	8, 9, 10, 12, 13, 15, 20, 22, 62	34, 36, 37, 38, 39, 40, 41, 43
High fuel consumption	11, 13, 15, 17, 18, 19, 21, 22	34, 36, 37, 38, 39, 40, 42, 43, 44
Black exhaust smoke	11, 13, 15, 17, 19, 21, 22	34, 36, 37, 38, 39, 40, 42, 43, 44
Blue or white exhaust smoke	4, 15, 21, 23, 62	36, 37, 38, 39, 42, 44, 45, 52, 58
The pressure of the lubricating oil is too low	4, 24, 25, 26	46, 47, 48, 50, 51, 59
The engine knocks	9, 13, 15, 17, 20, 22, 23, 62	36, 37, 40, 42, 44, 46, 52, 53, 60
The engine runs erratically	7, 8, 9, 10, 11, 12, 13, 15, 16, 18, 20, 22, 23	34, 38, 40, 41, 44, 52, 60
Vibration	13, 18, 20, 27, 28	34, 38, 39, 40, 41, 44, 52, 54
The pressure of the lubricating oil is too high	4, 25	49
The engine temperature is too high	11, 13, 15, 19, 27, 29, 30, 32, 61	34, 36, 37, 39, 52, 55, 56, 57
Crankcase pressure	31, 33	39, 42, 44, 45, 52
Bad compression	11, 22	37, 39, 40, 42, 43, 44, 45, 53, 60
The engine starts and stops	10, 11, 12	

List of possible causes

- 1 Battery capacity low.
- 2 Bad electrical connections.
- 3 Fault in starter motor.
- 4 Wrong grade of lubricating oil.
- 5 Starter motor turns engine too slowly.
- 6 Fuel tank empty.
- 7 Fault in stop control.
- 8 Restriction in a fuel pipe.
- 9 Fault in fuel lift pump.
- 10 Dirty fuel filter element.
- 11 Restriction in air filter/cleaner or induction system.
- 12 Air in fuel system.
- 13 Fault in atomisers or atomisers of an incorrect type.
- 14 Cold start system used incorrectly.
- 15 Fault in cold start system.
- 16 Restriction in fuel tank vent.
- 17 Wrong type or grade of fuel used.
- 18 Restricted movement of engine speed control.
- 19 Restriction in exhaust pipe.
- 20 Engine temperature is too high.
- 21 Engine temperature is too low.
- 22 Incorrect tappet clearances.
- 23 Too much oil or oil of a wrong specification is used in wet type air cleaner.
- 24 Not enough lubricating oil in sump.
- 25 Defective gauge.
- 26 Dirty lubricating oil filter element.
- 27 Fan damaged.
- 28 Fault in engine mounting or flywheel housing.
- 29 Too much lubricating oil in sump.
- 30 Restriction in air or water passages of radiator.
- 31 Restriction in breather pipe.
- 32 Insufficient coolant in system.
- 33 Vacuum pipe leaks or fault in exhaust.
- 34 Fault in fuel injection pump.
- 35 Broken drive on fuel injection pump.
- 36 Timing of fuel injection pump is incorrect.
- 37 Valve timing is incorrect.
- 38 Bad compression.
- 39 Cylinder head gasket leaks.
- 40 Valves are not free.
- 41 Wrong high-pressure pipes.
- 42 Worn cylinder bores.
- 43 Leakage between valves and seats.
- 44 Piston rings are not free or they are worn or broken.
- 45 Valve stems and/or guides are worn.
- 46 Crankshaft bearings are worn or damaged.
- 47 Lubricating oil pump is worn.
- 48 Relief valve does not close.
- 49 Relief valve does not open.
- 50 Relief valve spring is broken.
- 51 Fault in suction pipe of lubricating oil pump.
- 52 Piston is damaged.
- 53 Piston height is incorrect.
- 54 Flywheel housing or flywheel is not aligned correctly.
- 55 Fault in thermostat or thermostat is of an incorrect type.
- 56 Restriction in coolant passages.
- 57 Fault in water pump.
- 58 Valve stem seal is damaged (if there is one fitted).
- 59 Restriction in sump strainer.
- 60 Valve spring is broken.
- 61 Drive belt for water pump is loose.
- 62 Faulty cold start switch/faulty wiring.

Engine preservation	7
Introduction	7.02
Procedure	7.02

7 ENGINE PRESERVATION

Introduction

The recommendations indicated below are designed to prevent damage to the engine when it is withdrawn from service for a prolonged period. Use these procedures after the engine is withdrawn from service. The instructions for the use of POWERPART products are given on the outside of each container.

Procedure

- 1 Completely clean the outside of the engine.
- 2 When a preservative fuel is to be used, drain the fuel system and fill it with the preservative fuel. POWERPART Lay-Up 1 can be added to the normal fuel to change it to a preservative fuel. If preservative fuel is not used, the system can be completely filled with normal fuel but the fuel must be drained and discarded at the end of the storage period together with the fuel filter canister.
- 3 Operate the engine until it is warm. Then correct leakages of fuel, lubricating oil or air. Stop the engine and drain the lubricating oil from the sump.
- 4 Renew the canister of the lubricating oil filter.
- 5 Fill the sump to the full mark with new and clean lubricating oil and add POWERPART Lay-up 2 to the oil to protect the engine against corrosion. If POWERPART Lay-Up 2 is not available, use a correct preservative fluid instead of the lubricating oil. If a preservative fluid is used, this must be drained and the lubricating oil sump must be filled to the correct level with normal lubricating oil at the end of the storage period.
- 6 Drain the coolant circuit, see page 4.04. In order to protect the cooling system against corrosion, fill it with an approved antifreeze mixture because this gives protection against corrosion, see page 5.04.

Caution: If protection against frost is not necessary and a corrosion inhibitor is to be used, it is recommended that you consult the Service Department, Perkins International Limited, Peterborough.

- 7 Operate the engine for a short period in order to circulate the lubricating oil and the coolant in the engine.
- 8 Clean the engine breather pipe (if one is fitted) and seal the end of the pipe.
- 9 Remove the atomisers and spray POWERPART Lay-Up 2 for one to two seconds into each cylinder bore with the piston at BDC.

Slowly turn the crankshaft one revolution and then fit the atomisers, complete with new seat washers.

10 Remove the air filter. Then, if necessary, remove the pipe installed between the air filter and the induction manifold. Release the fasteners and remove the rocker cover. Spray POWERPART Lay-Up 2 around the rocker shaft assembly and into the induction ports in the cylinder head, as indicated on the container label. Fit the rocker cover. Seal the manifold with waterproof tape.

11 Remove the exhaust pipe. Spray POWERPART Lay-Up 2 into the exhaust manifold. Seal the manifold with waterproof tape.

12 Disconnect the battery. Then put the battery into safe storage in a fully charged condition. Before the battery is put into storage, protect its terminals against corrosion. POWERPART Lay-Up 3 can be used on the terminals.

13 Seal the vent pipe of the fuel tank or the fuel filler cap with waterproof tape.

14 Remove the alternator drive belt and put it into storage.

15 In order to prevent corrosion, spray the engine with POWERPART Lay-Up 3. Do not spray the area inside the alternator cooling fan.

Caution: After a period in storage, but before the engine is started, operate the starter motor with the stop switch (3.03/A) held in the "STOP" position until oil pressure is indicated. Oil pressure is indicated when the low pressure warning light is extinguished. If a solenoid stop control is used on the fuel injection pump, it must be disconnected for this operation.

If the engine protection is done correctly according to the above recommendations, no corrosion damage will normally occur. Perkins are not responsible for damage which may occur when an engine is in storage after a period in service.

Parts and service	8
Introduction	8.02
Service literature	8.02
Training	8.02
POWERPART consumable products	8.03

8 PARTS AND SERVICE

Introduction

If problems occur with your engine or with the components fitted onto it, your Perkins distributor can make the necessary repairs and will ensure that only the correct parts are fitted and that the work is done correctly.

Service literature

Workshop manuals, installation drawings and other service publications are available from your Perkins distributor at a nominal cost.

Training

Local training for the correct operation, service and overhaul of engines is available at certain Perkins distributors. If special training is necessary, your Perkins distributor can advise you how to obtain it at the Perkins Customer Training Department, Peterborough, or other main centres.

POWERPART consumable products

Perkins have made available the products recommended below in order to assist in the correct operation, service and maintenance of your engine and your machine. The instructions for the use of each product are given on the outside of each container. These products are available from your Perkins distributor.

POWERPART Antifreeze

Protects the cooling system against frost and corrosion. Part number 1 litre 21825166 or 5 litres 21825167, see page 5.04.

POWERPART Easy Flush

Cleans the cooling system. Part number 2182501.

POWERPART Jointing compound

Universal jointing compound which seals joints. Currently Hylomar. Part number 1861155 or 1861117.

POWERPART Silicone rubber sealant

Silicone rubber sealant which prevents leakage through gaps. Currently Hylosil Part number 1861108.

POWERPART Lay-Up 1

A diesel fuel additive for protection against corrosion. Part number 1772204, see page 7.02.

POWERPART Lay-Up 2

Protects the inside of the engine and of other closed systems. Part number 1762811, see page 7.02.

POWERPART Lay-Up 3

Protects outside metal parts. Part number 1734115, see page 7.02.

POWERPART Chisel

Allows easy removal of old gaskets and joints. Currently Loctite chisel. Part number 21825163.

POWERPART repel

Dries damp equipment and gives protection against corrosion. Passes through dirt and corrosion to lubricate and to assist removal of components. Currently Loctite repel. Part number 21825164.

POWERPART Threadlock

To retain small fasteners where easy removal is necessary. Currently Loctite 222e. Part number 21820222.

POWERPART Nutlock

To retain and seal threaded fasteners and cup plugs where easy removal is necessary. Currently Loctite 242e. Part number 21820242.

POWERPART Studlock

To permanently retain large fasteners and studs. Currently Loctite 270. Part number 21820270.

POWERPART Liquid gasket

To seal flat faces of components where no joint is used. Especially suitable for aluminium components. Currently Loctite 518. Part number 21820518.

POWERPART Threadlock (Hydraulic/Pneumatic)

To retain and seal pipe connections with fine threads. Especially suitable for hydraulic and pneumatic systems. Currently Loctite 542. Part number 2180542.

POWERPART Threadlock (pipe)

To retain and seal pipe connections with coarse threads. Pressure systems can be used immediately. Currently Loctite 575. Part number 21820575.

POWERPART Retainer (oil tolerant)

To retain components which have a transition fit. Currently Loctite 603. Part number 21820603.

POWERPART Retainer (high strength)

To retain components which have an interference fit. Currently Loctite 638. Part number 21820638.

Engine data

9

Engine data

9.02

9 ENGINE DATA

Engine data

Number of cylinders	3
Cylinder arrangement	In line
Cycle	Four stroke
Direction of rotation	Clockwise from the front
Induction system	Naturally aspirated
Combustion system	Direct injection
Nominal bore:	95,0 mm (3.74 in)
Stroke:	127 mm (5.00 in)
Compression ratio	17.5:1
Cubic capacity:	2,7 litres (164.76 in ³)
Firing order	1,2,3
Valve tip clearances (hot/cold):	
- Inlet	0,20 mm (0.008 in)
- Exhaust	0,45 mm (0.018 in)
Lubricating oil pressure (minimum at maximum engine speed and normal engine temperature) ...	207 kN/m ² (30.0 lb/in ²) 2,1 kgf/cm ²

CALIFORNIA

Proposition 65 Warning

Diesel engine exhaust and some of its constituents are known to the State of California to cause cancer, birth defects, and other reproductive harm.

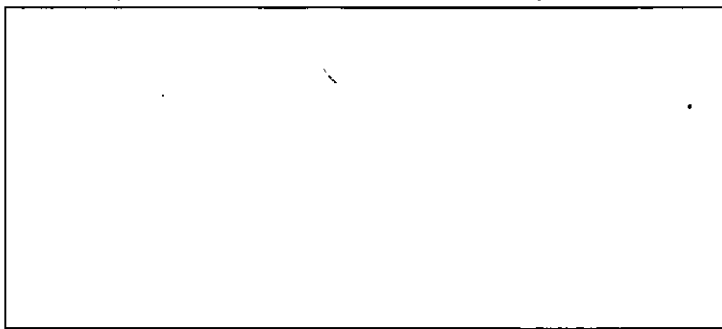

VARITYPerkins

Perkins Group of Companies

Peterborough PE1 5NA England