

OLYMPIAN™

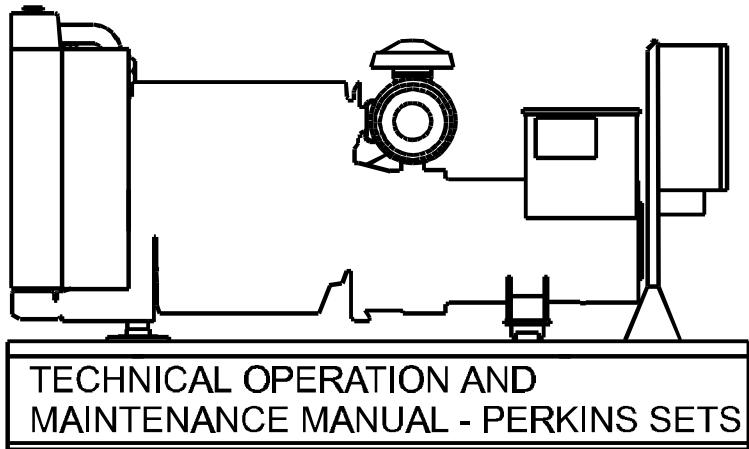

This manual has been designed as a technical guide to operating, servicing and maintaining the generator set. It should be used in conjunction with the Engine and Alternator Manuals.

An Operator's Manual is also included with these manuals to aid the operator specifically in starting, stopping and otherwise operating the set. The Operator's manual is available in any of a number of languages for non-English speaking operators.

Generator Set Serial Number:

Date of Purchase:	Date of Initial Startup/Commissioning:
Name & Address of Owner or Operator:	Name & Address of Generator set Dealer/Distributor:

GENERATOR SET TECHNICAL OPERATION AND MAINTENANCE MANUAL

Document: TMANP_US
Issue Date: 05/98

TABLE OF CONTENTS

Page

1. INTRODUCTION	1
2. SAFETY	1
2.1 General	1
2.2 Installation, Handling, and Towing	1
2.3 Fire and Explosion	1
2.4 Mechanical	2
2.5 Chemical	2
2.6 Noise	2
2.7 Electrical	2
2.8 First Aid For Electric Shock	3
3. GENERAL DESCRIPTION	5
3.1 Generator set Description and Identification	5
3.2 Diesel Engine	5
3.3 Engine Electrical System	5
3.4 Cooling System	5
3.5 Alternator	5
3.6 Fuel Tank and Baseframe	5
3.7 Vibration Isolation	5
3.8 Silencer and Exhaust System	5
3.9 Control System (Identification)	5
3.10 Output Circuit Breaker	5
4. INSTALLATION, HANDLING, TOWING AND STORAGE	6
4.1 General	6
4.2 Enclosures	6
4.3 Moving the Generator set	6
4.4 Location	6
4.5 Foundations and Vibration Isolation	7
4.6 Combustion Air Inlet	8
4.7 Cooling and Ventilation	8
4.8 Exhaust	9
4.9 Fuel System	10
4.10 Fire Precautions	11
4.11 Starting Batteries	11
4.12 Electrical Connection	12
4.13 Acoustic Silencing	12
4.14 Towing (Portable Generator sets)	12
4.15 Storage	13
5. OPERATION	14
5.1 General	14
5.2 Pre-Start Checks (applicable to all control systems)	14
5.3 Initial Startup/Shutdown - Key Start Panel (1001 Series)	14
5.4 Normal Startup/Shutdown - Key Start Panel (1001 Series)	15
5.5 Initial Startup/Shutdown - Autostart Panel (2001, 4001, or 4001E Series)	16
5.6 Normal Manual Startup/Shutdown - Autostart Panel (2001, 4001 or 4001E Series)	17
5.7 Automatic Startup/Shutdown - Autostart Panel (2001, 4001 or 4001E Series)	17
6. GENERATOR SET MAINTENANCE	17
6.1 General	17
6.2 Preventative Maintenance	18
6.3 Removal of Engine and/or Alternator	18
7. ENGINE DESCRIPTION AND MAINTENANCE	19
7.1 Engine Description	19
7.2 Engine Maintenance	19
7.3 Radiator Maintenance	19
8. ALTERNATOR DESCRIPTION AND MAINTENANCE	21
8.1 Alternator Description	21
8.2 Alternator Maintenance	21

9. CONTROL SYSTEM DESCRIPTION AND TROUBLE SHOOTING	22
9.1 Control System Description and Identification	22
9.2 Functional Description 1001 Series Control System	24
9.3 Functional Description 2001, 4001 and 4001E Series Control Systems	25
9.4 Control System Options and Upgrades.....	30
9.5 Control System Fault Finding/Trouble Shooting Guide	32
9.6 Load Transfer Panel	36
9.7 Engine Interface Module Description	38
9.8 Output Circuit Breaker Description.....	38
10. BATTERY DESCRIPTION AND MAINTENANCE	39
10.1 Battery Theory.....	39
10.2 Battery Maintenance	39
10.3 Charging the Battery	39
10.4 Battery Charging System Fault Finding/Trouble Shooting Chart.....	40
10.5 Jump Starting Procedures	41
HAZARD LABEL LEGEND	42
INDEX	43

1. INTRODUCTION

This generator set is one of a family of heavy duty industrial generator sets designed to be ready to run when it arrives, requiring only the addition of coolant, fuel and battery acid. Years of diesel generator set experience has gone into the set to produce a quality source of electrical power that is efficient and reliable.

This Technical Operation and Maintenance Manual has been prepared to assist in maintenance and operation of the generator set. Using this manual in conjunction with the Engine Manual, Alternator Manual and the Generator set Operator's Manual, will help to ensure that the generator set keeps operating at maximum performance and efficiency for a long life. Please note that in dirty or dusty environments more attention must be paid to frequent servicing to keep the set running properly.

Always ensure that adjustments and repairs are done by personnel who are authorized to do the work and have been properly trained.

Every generator set is uniquely defined by a model number and serial number indicated on a rating plate generally affixed to the alternator housing. This information is required when ordering spare parts or when service or warranty work is required. See Section 3.1 for further information.

2. SAFETY

2.1 General

The generator set is designed to be safe when used in the correct manner. Responsibility for safety, however, rests with the personnel who install, use and maintain the set. The following safety precautions, if followed, will minimize the possibility of accidents. Before performing any procedure or operating technique, it is up to the user to ensure that it is safe. The generator set should only be operated by personnel who are authorized and trained.

WARNING:

- ! Read and understand all safety precautions and warnings before operating or performing maintenance on the generator set.
- ! Failure to follow the instructions, procedures, and safety precautions in this manual may increase the possibility of accidents and injuries.
- ! Never start the generator set unless it is safe to do so.
- ! Do not attempt to operate the generator set with a known unsafe condition.
- ! If the generator set is unsafe, fit danger notices and disconnect the battery negative (-) lead so that it cannot be started until the condition is corrected.
- ! Disconnect the battery negative (-) lead prior to attempting any repairs or cleaning inside the enclosure, if equipped.
- ! Install and operate this generator set only in full compliance with relevant National, Local, or Federal Codes, Standards or other requirements.

2.2 Installation, Handling, and Towing

Chapter 4 of this manual covers procedures for installation, handling, and towing of generator sets. That chapter should be read before installing the generator set, moving/lifting the generator set, or towing a mobile set. The following safety precautions should be noted:

WARNING:

- ! Make electrical connections in compliance with relevant Electrical Codes, Standards or other requirements. This includes requirements for grounding and ground/earth faults.
- ! For stationary generator sets with remote fuel storage systems, make sure such systems are installed in compliance with relevant Codes, Standards or other requirements.
- ! Engine exhaust emissions are hazardous to personnel. The exhaust for all indoor generator sets must be piped outdoors via leak-free piping in compliance with relevant Codes, Standards and other requirements. Ensure hot exhaust silencers, piping and turbochargers, if equipped, are clear of combustible material and are guarded for personnel protection per safety requirements. Ensure that fumes from the exhaust outlet will not be a hazard.
- ! Never lift the generator set by attaching to the engine or alternator lifting lugs. Use a sling with a "spreader bar" connected to the baseframe.
- ! Ensure the lifting rigging and supporting structure is in good condition and has a capacity suitable for the load.
- ! Keep all personnel away from the generator set when it is suspended.
- ! Make sure all personnel are out of the generator set canopy or container, if equipped, before closing and latching enclosure doors.
- ! When towing a mobile generator set, observe all Codes, Standards or other regulations and traffic laws. These include those regulations specifying required equipment and maximum and minimum speeds. Ensure brakes, if fitted, are in good order.
- ! Do not permit personnel to ride in or on the mobile generator set. Do not permit personnel to stand or ride on the drawbar or to stand or walk between the generator set and the towing vehicle.
- ! Do not install or use the generator set in any classification of hazardous environment unless it has been specifically designed for that environment.

2.3 Fire and Explosion

Fuels and fumes associated with generator sets can be flammable and potentially explosive. Proper care in handling these materials can dramatically limit the risk of fire or explosion. However, safety dictates that fully charged BC and ABC fire extinguishers are kept on hand. Personnel must know how to operate them.

WARNING:

- ! Ensure the generator set room is properly ventilated.
- ! Keep the room, the floor and the generator set clean. When spills of fuel, oil, battery electrolyte or coolant occur, they should be cleaned up immediately.
- ! Never store flammable liquids near the engine.
- ! Store oily rags in covered metal containers.
- ! Do not smoke or allow sparks, flames or other sources of ignition around fuel or batteries. Fuel vapors are explosive. Hydrogen gas generated by charging batteries is also explosive.
- ! Turn off or disconnect the power to the battery charger before making or breaking connections with the battery.

- ! Keep grounded conductive objects, such as tools, away from exposed live electrical parts, such as terminals, to avoid arcing. Sparks and arcing might ignite fuel or vapors.
- ! Avoid refilling the fuel tank while the engine is running.
- ! Do not attempt to operate the generator set with any known leaks in the fuel system.
- ! The excessive build-up of unburned fuel gases in the exhaust system can create a potentially explosive condition. This build-up can occur after repeated failed start attempts, air flap valve testing, or hot engine shutdown. Open exhaust system purge plugs, if equipped, and allow the gases to dissipate before attempting to restart the generator set.

2.4 Mechanical

The generator set is designed with guards for protection from moving parts. Care must still be taken to protect personnel and equipment from other mechanical hazards when working around the generator set.

WARNING:

- ! Do not attempt to operate the generator set with safety guards removed. While the generator set is running do not attempt to reach under or around the guards to do maintenance or for any other reason.
- ! Keep hands, arms, long hair, loose clothing and jewelry away from pulleys, belts and other moving parts.
Attention: Some moving parts can not be seen clearly when the set is running.
- ! Keep access doors on enclosures, if equipped, closed and locked when not required to be open.
- ! Avoid contact with hot oil, hot coolant, hot exhaust gases, hot surfaces and sharp edges and corners.
- ! Wear protective clothing including gloves and hat when working around the generator set.
- ! Do not remove the radiator filler cap until the coolant has cooled. Then loosen the cap slowly to relieve any excess pressure before removing the cap completely.
- ! Ethyl Ether starting aids **must not** be used on engines with combustion air preheating devices or on engines manufactured by the Detroit Diesel Corporation (DDC). In general these starting aids are not recommended on any engine. They will reduce the efficient working life of the engine.

2.5 Chemical

Fuels, oils, coolants, lubricants and battery electrolyte used in this generator set are typical of the industry. However, they can be hazardous to personnel if not treated properly.

WARNING:

- ! Do not swallow or have skin contact with fuel, oil, coolant, lubricants or battery electrolyte. If swallowed, seek medical treatment immediately. Do not induce vomiting if fuel is swallowed. For skin contact, wash with soap and water.
- ! Do not wear clothing that has been contaminated by fuel or lube oil.
- ! Wear an acid resistant apron and face shield or goggles when servicing the battery. If electrolyte is spilled on skin or clothing, flush immediately with large quantities of water.

2.6 Noise

Generator sets that are not equipped with sound attenuating enclosures can produce noise levels in excess of 105 dBA. Prolonged exposure to noise levels above 85 dBA is hazardous to hearing.

WARNING:

- ! Ear protection must be worn when operating or working around an operating generator set.

2.7 Electrical

Safe and efficient operation of electrical equipment can be achieved only if the equipment is correctly installed, operated and maintained.

WARNING:

- ! The generator set must be connected to the load only by trained and qualified electricians who are authorized to do so, and in compliance with relevant Electrical Codes, Standards and other regulations. Where required, their work should be inspected and accepted by the inspection agency prior to operating the generator set.
- ! Ensure the generator set, including a mobile set, is effectively grounded/earthed in accordance with all relevant regulations prior to operation.
- ! The generator set should be shutdown with the battery negative (-) terminal disconnected prior to attempting to connect or disconnect load connections.
- ! Do not attempt to connect or disconnect load connections while standing in water or on wet or soggy ground.
- ! Do not touch electrically energized parts of the generator set and/or interconnecting cables or conductors with any part of the body or with any non insulated conductive object.
- ! Replace the generator set terminal box cover as soon as connection or disconnection of the load cables is complete. Do not operate the generator set without the cover securely in place.
- ! Connect the generator set only to loads and/or electrical systems that are compatible with its electrical characteristics and that are within its rated capacity.
- ! Be sure all electrical power is disconnected from electrical equipment being serviced.
- ! Keep all electrical equipment clean and dry. Replace any wiring where the insulation is cracked, cut, abraded or otherwise degraded. Replace terminals that are worn, discolored or corroded. Keep terminals clean and tight.
- ! Insulate all connections and disconnected wires.
- ! Use only Class BC or Class ABC extinguishers on electrical fires.

2.8 First Aid For Electric Shock

WARNING:

- ! Do not touch the victim's skin with bare hands until the source of electricity has been turned off.
- Switch off power, if possible.
- Otherwise pull the plug or pull the cable away from the victim.
- If this is not possible, stand on dry insulating material and pull the victim clear of the conductor, preferably using insulated material such as dry wood.
- If victim is breathing, turn the victim into the recovery position described below.
- If victim is unconscious, perform resuscitation as required:

OPEN THE AIRWAY:

1. Tilt the victim's head back and lift the chin upwards.
2. Remove objects from the mouth or throat (including false teeth, tobacco, or chewing gum).



BREATHING:

1. Check that the victim is breathing by looking, listening and feeling for the breath.

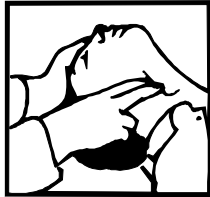

CIRCULATION:

1. Check for pulse in the victim's neck.

IF NO BREATHING BUT PULSE IS PRESENT:

1. Pinch the victim's nose firmly.
2. Take a deep breath and seal your lips around the victim's lips.
3. Blow slowly into the mouth watching for the chest to rise. Let the chest fall completely. Give breaths at a rate of 10 per minute.
4. If the victim must be left to get help, give 10 breaths first and then return quickly and continue.
5. Check for pulse after every 10 breaths.
6. When breathing restarts, place the victim into the recovery position described later in this section.



IF NO BREATHING AND NO PULSE:

1. Call or telephone for medical help.
2. Give two breaths and start chest compression as follows:
3. Place heel of hand 2 fingers breadth above ribcage/breastbone junction.
4. Place other hand on top and interlock fingers.
5. Keeping arms straight, press down 4-5 cm (1.5-2 inch) 15 times at a rate of 80 per minute.
6. Repeat cycle (2 breaths, 15 compressions) until medical help takes over.
7. If condition improves, confirm pulse and continue with breaths. Check for pulse after every 10 breaths.
8. When breathing restarts, place the victim into the recovery position described below.

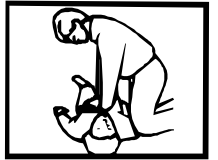

RECOVERY POSITION:

1. Turn the victim onto the side.
2. Keep the head tilted with the jaw forward to maintain the open airway.
3. Make sure the victim cannot roll forwards or backwards.
4. Check for breathing and pulse regularly. If either stops, proceed as above.

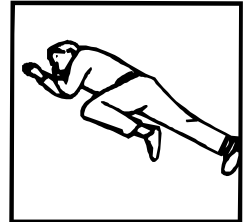

WARNING:

- ! Do not give liquids until victim is conscious.

Figure 3.1: Typical Generator set Configuration

3. GENERAL DESCRIPTION

3.1 Generator set Description and Identification

This generator set has been designed as a complete package to provide superior performance and reliability. Figure 3.1 identifies the major components. This figure is of a typical generator set. However, every set will be slightly different due to the size and configuration of the major components. This section briefly describes the parts of the generator set. Further information is provided in later sections of this manual.

Each generator set is provided with a Rating Label (item 1) generally affixed to the alternator housing. This label contains the information needed to identify the generator set and its operating characteristics. This information includes, but is not limited to, the model number, serial number, output characteristics such as voltage, phase and frequency, output rating in kVA and kW, and rating type (basis of the rating). For reference, this information is repeated on the Technical Data Sheet provided with this manual. The model and serial numbers uniquely identify the generator set and are needed when ordering spare parts or obtaining service or warranty work for the set.

3.2 Diesel Engine

The diesel engine powering the generator set (item 2) has been chosen for its reliability and the fact that it has been specifically designed for powering generator sets. The engine is of the heavy duty industrial type with 4 stroke or 2 stroke compression ignition and is fitted with all accessories to provide a reliable power supply. These accessories include, among others, a cartridge type dry air filter (item 3), a turbocharger fitted on some engines (item 4), and a mechanical or electronic close control engine speed governor (item 5).

3.3 Engine Electrical System

The engine electrical system is negative ground/earth and either 12 or 24 volts DC depending on the size of the set. This system includes an electric engine starter (item 6), battery and battery rack (item 7) which may also be located on the floor next to the set for some of the larger generator sets, and a battery charging alternator (item 8). Most sets are provided with lead-acid batteries which are discussed more fully in Section 10, however other types of batteries may be fitted if they had been specified.

3.4 Cooling System

The engine cooling system is comprised of a radiator (item 9), a high capacity pusher fan and a thermostat. The alternator has its own internal fan to cool the alternator components. Note that the air is "pushed" through the radiator so that the cooling air is drawn past the alternator, then past the engine and finally through the radiator.

3.5 Alternator

The output electrical power is normally produced by a screen protected and drip-proof, self-exciting, self-regulating, brushless alternator (item 10) fine tuned to the output of this generator set. Mounted on top of the alternator is a sheet steel terminal box (item 11).

3.6 Fuel Tank and Baseframe

The engine and alternator are coupled together and mounted on a heavy duty steel baseframe (item 12). Except for the largest sets, this baseframe includes a fuel tank with a capacity of approximately 8 hours operation at full load. An extended capacity fuel tank of approximately 24 hours operation may be fitted. Where a fuel tank is not provided with the baseframe, a separate fuel tank must be provided.

3.7 Vibration Isolation

The generator set is fitted with vibration isolators (item 13) which are designed to reduce engine vibration being transmitted to the foundation on which the generator set is mounted. These isolators are fitted between the engine/alternator feet and the baseframe. Alternately, on larger models the engine/alternator is rigidly mounted on the baseframe and the vibration isolators are supplied loose to be fitted between the baseframe and the foundation.

3.8 Silencer and Exhaust System

An exhaust silencer is provided loose for installation with the generator set. The silencer and exhaust system reduce the noise emission from the engine and can direct exhaust gases to safe outlets.

3.9 Control System (Identification)

One of several types of control systems and panels (item 14) may be fitted to control the operation and output of the set and to protect the set from possible malfunctions. Section 9 of this manual provides detailed information on these systems and will aid in identification of the control system fitted on the generator set.

3.10 Output Circuit Breaker

To protect the alternator, a suitably rated circuit breaker (item 15) selected for the generator set model and output rating is supplied mounted in a steel enclosure. In some cases the output circuit breaker may be incorporated in the automatic transfer system or control panel.

4. INSTALLATION, HANDLING, TOWING AND STORAGE

4.1 General

This section discusses factors important in the effective and safe installation of the generator set. Further information is available in the **Generator set Installation Manual** which is available upon request.

4.2 Enclosures

Installation and handling is greatly simplified when the generator set has been equipped with an enclosure. Two basic types may be fitted. The first type is a close fitting canopy enclosure. This may be a weatherproof version or designed for sound attenuation. The other enclosure type is a walk-in type container, similar to a shipping container. It may also be weatherproof or sound attenuated.

These enclosures provide a self contained generator set system that is easily transportable and requires minimal installation. They also automatically give protection from the elements and protection from unauthorized access.

WARNING:

- ! **Make sure all personnel are out of the canopy or container, if equipped, before closing and latching enclosure doors.**
- ! **Before closing canopy or enclosure doors, ensure all obstructions (especially hands and fingers) are clear to prevent damage or injury.**

Because the canopied generator sets are easily transportable and may be installed and operated in a temporary location, many of the fixed installation details given in this chapter may not apply. The following considerations must be still given when temporarily installing the generator set:

- Locating the generator set where it will be protected from damage and away from exhaust fumes from other engines or other airborne contaminants such as dust, lint, smoke, oil mist or vapors.
- Locating the generator set on firm, level ground that will support the weight of the generator set and avoid movement due to the vibration of the operating set.
- Ensuring that fumes from the exhaust outlet will not be a hazard especially when wind is taken into account.
- Electrical grounding of the generator set at all times.
- Providing access to refill the fuel tank when required.
- Protecting electrical cables installed between the generator set and the load. If these are laid on the ground ensure they are boxed in or covered to prevent damage or injury to personnel.

If the enclosed generator set is installed inside a building, adequate fresh cooling air must be provided and the engine exhaust and hot coolant air exhaust must be ducted outside the building. The ducting and exhaust pipework must be designed to minimize back pressure which would have a detrimental effect on generator set performance.

4.3 Moving the Generator set

The generator set baseframe is specifically designed for ease of moving the set. Improper handling can seriously damage components.

Using a forklift, the generator set can be lifted or carefully pushed/pulled by the baseframe. If pushing, do not push the baseframe directly with fork. Always use wood between forks and the baseframe to spread the load and prevent damage. If the set will be regularly moved, it should be fitted with the optional "Oil Field Skid" which provides fork lift pockets in the baseframe along with eyes for pulling. The smaller sets have fork lift pockets in the baseframe as standard.

WARNING:

- ! **Never lift the generator set by attaching to the engine or alternator lifting lugs.**

- ! **Ensure the lifting rigging and supporting structure is in good condition and is suitably rated.**
- ! **Keep all personnel away from the generator set when it is suspended.**

For ease of lifting, canopied sets have a single point lifting facility as standard.

For walk-in type enclosures lifting attachment is by means of corner fittings on the enclosure. Generator sets in these enclosures are fitted with restraining angles to rigidly attach the engine and alternator to the baseframe during transit. Ensure the restraints are fitted securely in place before moving the generator set. Once the generator set has been moved these restraints must be removed before attempting to operate the set.

For a single lift such as lifting the set to install it, the lift points provided on the baseframe may be used. Points of attachment should be checked for cracked welds or loose nuts and bolts before lifting. A spreader bar is required to prevent damaging the set (see Figure 4.1). It should be positioned over the center of gravity (nearer the engine), not the center of the set, to allow a vertical lift. Guide ropes should be used to prevent twisting or swinging of the set once it has been lifted clear of the ground - do not attempt to lift in high winds. Place the generator set down on a level surface capable of supporting its weight. This manner of lifting should only be used for a single lift for installation.

Generator sets to be air lifted by helicopter should be lifted by sling.

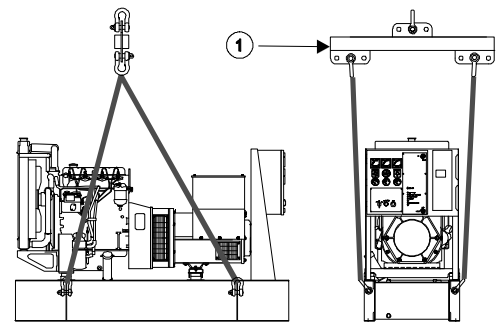

Item	Description
1.	Spreader Bar

Figure 4.1: Proper Lifting Arrangement for Installing the Set

4.4 Location

Selecting a location for the generator set can be the most important part of any installation procedure. The following factors are important in determining the location:

- Adequate ventilation.
- Protection from the elements such as rain, snow, sleet, wind driven precipitation, flood water, direct sunlight, freezing temperatures, or excessive heat.
- Protection from exposure to airborne contaminants such as abrasive or conductive dust, lint, smoke, oil mist, vapors, engine exhaust fumes or other contaminants.
- Protection from impact from falling objects such as trees or poles, or from motor vehicles or lift trucks.
- Clearance around the generator set for cooling and access for service: at least 1 meter (3.3 feet) around the set and at least 2 meters (6.6 feet) headroom above the set.
- Access to move the entire generator set into the room. Air inlet and outlet vents can often be made removable to provide an access point.
- Limited access to unauthorized personnel.

<u>Item</u>	<u>Description</u>
1.	Vibration Isolators
2.	Flexible Exhaust Coupling
3.	Flexible Air Discharge Duct

Figure 4.2: Typical Installation Highlighting Vibration Reduction Techniques

If it is necessary to locate the generator set outside of the building, the generator set should be enclosed in a weatherproof canopy or container-type housing which is available for all sets. These enclosures are also useful for temporary installations inside or outside the building.

4.5 Foundations and Vibration Isolation

The generator set is shipped assembled on a rigid baseframe that precisely aligns the alternator and engine and needs only be bolted down to a suitably prepared surface (see Figure 4.2).

4.5.1 Foundation: A reinforced concrete pad makes the best foundation for the generator set. It provides a rigid support to prevent deflection and vibration. Typically the foundation should be 150 mm to 200 mm (6 to 8 inches) deep and at least as wide and long as the generator set. The ground or floor below the foundation should be properly prepared and should be structurally suited to carry the weight of the foundation pad and the generator set. (If the generator set is to be installed above the ground floor the building structure must be able to support the weight of the generator set, fuel storage and accessories.) Relevant building codes should be consulted and complied with. If the floor may be wet from time to time, such as in a boiler room, the pad should be raised above the floor. This will provide a dry footing for the generator set and for those who connect, service or operate it. It will also minimize corrosive action on the baseframe.

4.5.2 Vibration Isolation: To minimize engine vibrations being transmitted to the building, the generator set is fitted with vibration isolators. On small and medium sized sets these isolators are fitted between the engine/alternator feet and the baseframe. This allows the frame to be rigidly bolted to the foundation. On larger sets the coupled engine/alternator is rigidly attached to the baseframe and the vibration isolators are supplied loose for fitting between the baseframe and the foundation. In all cases the sets should be securely bolted to the ground (either through the baseframe or through the vibration isolators) to prevent movement.

Vibration isolation is also required between the generator set and its external connections. This is achieved by use of flexible connections in the fuel lines, exhaust system, radiator air discharge duct, electrical conduit for control and power cables and other externally connected support systems (see Figure 4.2).

On mobile sets the generator set should be mounted using "captivation mounts". These mounts minimize vibration and include a captivation feature that prevents the set breaking away in case of road accident.

4.6 Combustion Air Inlet

Air for engine combustion must be clean and as cool as possible. Normally this air can be drawn from the area surrounding the generator set via the engine mounted air filter.

However, in some cases due to dust, dirt, or heat, the air around the set is unsuitable. In these cases an inlet duct should be fitted. This duct should run from the source of clean air (outside the building, another room, etc.) to the engine mounted air filter. Do not remove the air filter and mount it at a remote location as this can increase the possibility of dirt leaking through the ductwork and into the engine inlet. To ensure that this type of installation will not have a detrimental effect on the operation of the generator set, the design of the inlet duct should be approved by the factory.

4.7 Cooling and Ventilation

The engine, alternator, and exhaust piping radiate heat which can result in a temperature high enough to adversely effect the performance of the generator set. It is therefore important that adequate ventilation is provided to keep the engine and alternator cool. Proper air flow, as shown in Figure 4.3, requires that the air comes in at the

alternator end of the set, passes over the engine, through the radiator and out of the room via a flexible exhaust duct. Without the ducting of the hot air outside the room, the fan will tend to draw that hot air around and back through the radiator, reducing the cooling effectiveness.

The air inlet and exit openings should be large enough to ensure free flow of air into and out of the room. As a rough guide the openings should each be at least 1.5 times the area of the radiator core.

Both the inlet and exit openings should have louvres for weather protection. These may be fixed but preferably should be movable in cold climates so that while the generator set is not operating the louvres can be closed. This will allow the room to be kept warm which will assist starting and load acceptance. For automatic starting generator sets, if the louvres are movable they must be automatically operated. They should be programmed to open immediately upon starting the engine. The force of radiator air should not be depended upon to open the louver vanes unless the system has been specifically designed for this.

When a remote radiator or heat exchanger cooling system is used, the radiated heat from the generator set must still be removed from the room.

<u>Item</u>	<u>Description</u>
1.	Air Inlet Opening
2.	Air Exit Opening

Figure 4.3: Air Ventilation

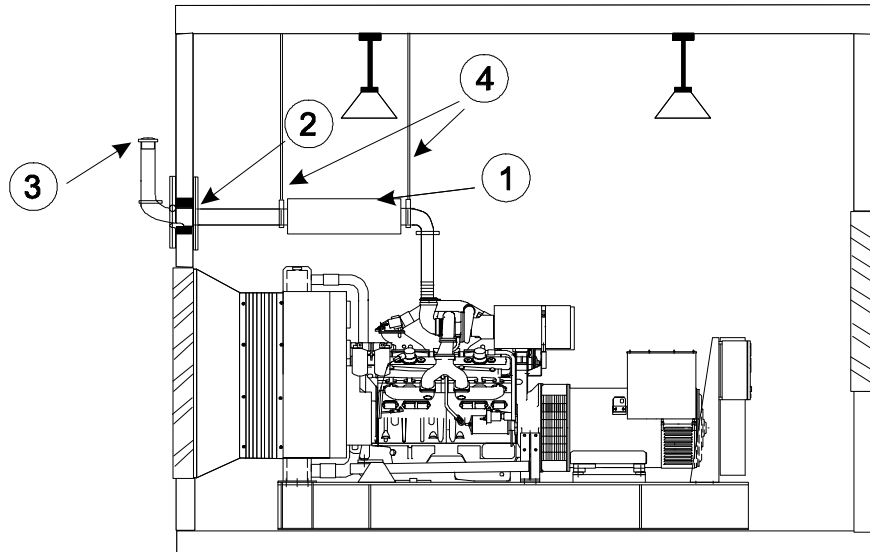

Item	Description
1.	Exhaust Silencer
2.	Wall Sleeve and Expansion Joint
3.	Rain Cap
4.	Silencer/Pipework Supports

Figure 4.4: Typical Exhaust System Installation

4.8 Exhaust

The purpose of the engine exhaust system is to direct the exhaust outside to a location and height where the fumes and odors will not become an annoyance or hazard, and to reduce noise. A suitable exhaust silencer must be incorporated into the exhaust piping to reduce the noise level from the engine. It can be fitted either inside or outside the building (see Figure 4.4). Canopied generator sets include exhaust system within the enclosure.

Open generator sets will generally be supplied with a loose industrial class silencer, a stub pipe and a bellows (if required). An optional "Overhead Mounting Kit" includes a bend, silencer support brackets and a bellows (if not standard). An optional "Silencer Installation Kit" includes the wall sleeve, bend and rain cap for directing the exhaust outside (see Figure 4.4). In all cases, the straight sections of pipe and screw rods for the support brackets are supplied by the customer.

WARNING:

- ! **Engine exhaust emissions are hazardous to personnel.**
- ! **The engine exhaust for all indoor generator sets must be piped outdoors via leak-free piping in compliance with relevant Codes, Standards and other requirements.**
- ! **Ensure hot exhaust silencers, piping and turbochargers, if fitted, are clear of combustible material and are guarded for personnel protection per safety requirements.**
- ! **Ensure that fumes from the exhaust outlet will not be a hazard.**

In designing an exhaust system, the primary consideration is to not exceed the allowable back pressure permitted by the engine manufacturer. Excessive back pressure seriously affects engine output, durability and fuel consumption. To limit the back pressure the exhaust piping should be as short and straight as possible. Any required bends should have a curve radius of at least 1.5 times the inside diameter of the pipe. Any designed exhaust extensions over 3 meters should be approved by the factory.

Other exhaust design criteria are as follows:

- Exhaust components including turbochargers can be very hot and must be guarded where they could be accidentally touched.
- A flexible connection between the exhaust manifold and the piping system should be used to prevent transmission of engine vibration to the piping and the building and to allow for thermal expansion and any slight misalignment of the piping. (See Figure 4.2)
- Ensure that the silencer and all pipes are well supported to limit strain on the connectors which could result in cracks or leaks.
- Exhaust system components located within the generator room should be insulated to reduce heat radiation and noise levels. Pipes and the silencer, whether located inside or outside the building, should be located well clear of any combustible material.
- Any long horizontal or vertical piping should slope away from the engine and include drain traps at their lowest points to prevent water from reaching the engine or silencer.
- On generator sets above 150 kVA the silencer installation must include a purge plug for venting of the exhaust system in the event of difficult starting. The plug should be located adjacent to the exhaust flange and positioned to allow access.
- Where the pipe goes through a wall there should be a sleeve in the opening to absorb vibration and isolate combustible material from the hot pipes (See Figure 4.4). There may also be an expansion joint in the pipe to compensate for lengthwise thermal expansion or contraction.
- The outer end of the exhaust pipe, if horizontal, should be cut at 60° to the horizontal or should be fitted with a rain hood or cap, if vertical, to prevent rain or snow from entering the exhaust system.
- The exhaust pipe must not be connected to exhausts from other generator sets or other equipment, such as a furnace or boiler.

valves and operate the manual pump. When the required fuel level is reached, cease operating the manual fuel pump and close the isolating valves.

Fuel System 2: The bulk tank is located higher than the basetank. With this system the fuel is gravity fed from the bulk tank to the basetank. See figure 4.6.

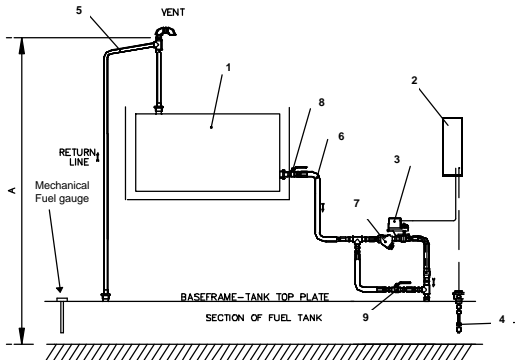

Figure 4.6: Typical Layout with Fuel System 2

The key components are the bulk fuel tank (item 1), which is higher than the basetank, remote fuel system controls (item 2) located in the generator set control panel, a DC motorized fuel valve (item 3), fuel level switches in the basetank (item 4), an extended vent/return line (continuous rise) on the basetank (item 5), the fuel supply line (item 6), a fuel strainer (item 7) and an isolating valve at the bulk tank (item 8).

When set to automatic, the system operates as follows: low fuel level in the basetank is sensed by the fuel level sensor. The DC motorized valve is opened and fuel is allowed to flow from the high level bulk tank to the basetank by the force of gravity. To help ensure that clean fuel reaches the engine, fuel from the bulk tank is strained just prior to the motorized valve. When the basetank is full, as sensed by the fuel level sensor, the motorized valve is closed. Any overflow into the basetank or overpressure in the basetank will flow back to the bulk tank via the extended vent.

With this system, the basetank must include an overflow via the return line, sealed fuel level gauges and no manual fill facility. All other connections on top of the tank must be sealed to prevent leakage. Fuel System 2 is not compatible with the polyethylene fuel tanks sometimes used on smaller generator sets. The optional metal tank is required.

Distance 'A' in Figure 4.6 is limited to 1400mm for all generator sets with metal basetanks.

Also available as an upgrade to the fuel transfer system is a manual backup system. Upon failure of the automatic transfer system, the manual backup can be used to transfer fuel from the main bulk tank to the generator set basetank. The manual backup system consists of a bypass with a manually operated shutoff valve. When the fuel level in the generator basetank is low (as observed by using the mechanical fuel gauge), open the manual shut-off valve in the bypass circuit. When the required fuel level is reached close the manual shut-off valve in the bypass circuit.

Fuel System 4: Some installations may require a system where fuel is pumped from a free standing bulk tank (see Figure 4.7). This pumped system would only be used if gravity feed is not possible from the bulk tank to the basetank.

The key components are the above ground bulk fuel tank (item 1), remote fuel system controls (item 2) located in the generator set control panel, an AC Fuel Pump (item 3), a DC motorized fuel valve (item 4), fuel level switches in the basetank (item 5), the fuel supply line (item 6), an extended vent/return line (continuous rise) on the basetank (item 7), a

fuel strainer (item 8) and an isolating valve at the bulk tank (item 9).

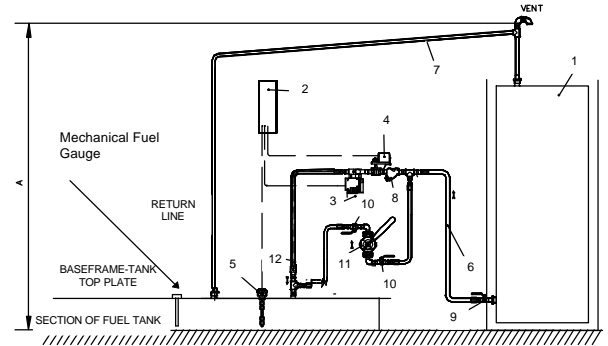

Figure 4.7: Typical Layout with Fuel System 4

When set to automatic, the system operates as follows: low fuel level in the basetank is sensed by the fuel level sensor. The DC motorized valve is opened and the pump begins to pump fuel from the bulk tank to the basetank through the supply line. To help ensure that clean fuel reaches the engine, fuel from the bulk tank is strained just prior to the motorized valve. When the basetank is full, as sensed by the fuel level sensor, the pump stops and the motorized valve is closed. Any overflow into the basetank or overpressure in the basetank will flow back to the bulk tank via the extended vent.

With this system, the basetank must include an overflow via the return line, sealed fuel level gauges and no manual fill facility. All other connections on top of the tank must be sealed to prevent leakage. Fuel System 4 is not compatible with the polyethylene fuel tanks sometimes used on smaller generator sets. The optional metal tank is required.

Distance 'A' on Figure 4.7 is limited to 1400mm for all generator sets. Note that the maximum restriction caused by friction losses and height of the return line should not exceed 2 psi.

Also available as an upgrade to the fuel transfer system is a manual backup system. Upon failure of the automatic transfer system, the manual backup can be used to transfer fuel from the main bulk tank to the generator set basetank. The key components in the manual backup system are isolating valves (item 10), manual fuel pump (item 11), and non-return valve (item 12). When the fuel level in the generator basetank is low (as observed by using the mechanical fuel gauge), open the manual pump isolating valves and operate the manual pump. When the required fuel level is reached, cease operating the manual fuel pump and close the isolating valves.

4.10 Fire Precautions

When designing the generator set installation the following points should be considered:

- The room should be designed so that there is an easy escape route for operating personnel in the event of fire within the room.
- Supply a Class BC or Class ABC fire extinguisher and/or fire extinguishing system.
- Gravity operated fire valves released by temperature operated fusible links mounted above the engine can be installed in the fuel lines.

4.11 Starting Batteries

WARNING:

- ! **Do not smoke or allow sparks, flames or other sources of ignition around batteries. Hydrogen gas generated by charging batteries is explosive.**

The starting batteries should be located as close as possible to the generator set while still being accessible for servicing. This will prevent electrical losses from long cables that could impact on the engine starting capability of the batteries. See Section 10.

4.12 Electrical Connection

Onsite electrical installation will generally consist only of connecting up the site load to the generator set output terminals. Only fully qualified and experienced electrical technicians should carry out electrical installation, service and repair work.

WARNING:

! **Make electrical connections in compliance with relevant Electrical Codes, Standards or other requirements. This includes requirements about grounding and ground/earth faults.**

4.12.1 Cabling: Due to movement of generator sets on their vibration mounts, the electrical connection to the set should be made with flexible cable. This will prevent transmission of vibrations and possible damage to the alternator or circuit breaker terminals. If flexible cabling can not be used throughout the installation then a link box should be installed close to the set with a flexible connection to the set.

The cable should be protected by laying it in a duct or cable tray. However, the duct or tray should never be rigidly connected to the generator set. When bending cable, reference must be made to the recommended minimum bending radius.

The cable must be suitable for the output voltage of the generator set and the rated current of the set. In determining the size, allowances should be made for ambient temperature, method of installation, proximity of other cables, etc. When single core cables are used the gland plates must be of non-ferrous material such as aluminum, brass or a non-metallic material such as tufnol. Alternatively slots can be cut between gland holes of cables to prevent circulating (eddy) currents in magnetic gland plates.

All connections should be carefully checked for integrity. Phase rotation must be checked for compatibility with the installation. This is vitally important when connection is made to an automatic transfer switch, or if the machine is to be paralleled.

4.12.2 Protection: The cables connecting the generator set with the distribution system are protected by means of a circuit breaker to automatically disconnect the set in case of overload or short circuit.

4.12.3 Loading: When planning the electrical distribution system it is important to ensure that a balanced load is presented to the generator set. If loading on one phase is substantially higher than the other phases it will cause overheating in the alternator windings, imbalance in the phase to phase output voltage and possible damage to sensitive 3 phase equipment connected to the system. Ensure that no individual phase current exceeds the current rating of the generator set. For connection to an existing distribution system, it may be necessary to reorganize the distribution system to ensure these loading factors are met.

4.12.4 Power Factor: The power factor ($\cos \Phi$) of the connected load should be determined. Power factors below 0.8 lagging (inductive) can overload the generator. The set will provide its kilowatt rating and operate satisfactorily from 0.8 lagging to unity power factor (1.0).

Particular attention must be given to installations with automatic or manual power factor correction equipment such as capacitors to ensure that a leading power factor is never present. This will lead to voltage instability and may result in damaging overvoltages. Generally, whenever the generator

set is supplying the load any power factor correction equipment should be switched off.

4.12.5 Grounding Requirements: Regulations vary for different locations. The frame of the generator set must be positively connected to an earth ground. Since the set is mounted on vibration isolators, the ground connection must be flexible to avoid possible breakage due to vibration. On the majority of self contained sets the ground connection is located inside the circuit breaker box.

Ground connection cables or straps should have at least full load current carrying capacity and meet applicable regulations.

4.12.6 Alternator Reconnection: Most alternators can be reconnected to suit different output voltages. The reconnection procedures are given in the Alternator Manual. Ensure that all other components such as circuit breakers, current transformers, cables and ammeters are suitable before operating at a different voltage.

4.12.7 Parallel Running: Extra equipment must be fitted for the standard generator sets to be operated in parallel with other generator sets or with mains power.

4.12.8 Insulation Test: Before starting the generator set after installation, test the insulation resistance of the windings. The Automatic Voltage Regulator (AVR) should be **disconnected** and the rotating diodes either shorted out with temporary links or disconnected. Any control wiring must also be disconnected.

A 500V Megger or similar instrument should be used. Disconnect any earthing conductor connected between neutral and earth and megger an output terminal to earth. The insulation resistance should be in excess of $5M\Omega$ to earth. Should the insulation resistance be less than $5M\Omega$ the winding must be dried out. See the Alternator Manual for procedures.

4.13 Acoustic Silencing

Control of generator set noise is becoming very important in most installations. There is a range of options available to control the noise level.

WARNING:

! **Ear protection must be worn when operating or working around an operating generator set.**

4.13.1 Exhaust Silencers: As discussed in Section 4.8 the exhaust silencer will decrease sound levels from the engine. Varying degrees of sound attenuation are available from different types of silencers. These levels are often described by terms such as industrial, residential, critical or supercritical.

4.13.2 Enclosures: Section 4.2 discusses enclosures that are available in either weatherproof or sound attenuating versions. These enclosures can be designed to meet a specific sound level requirement.

4.13.3 Other Sound Attenuation: For installations in buildings there are other types of equipment such as acoustic louvers, splitter vents and fan silencers, as well as sound absorbing wall coverings, that can be used to reduce the noise levels of generator sets.

4.14 Towing (Portable Generator sets)

4.14.1 Preparing to Tow: Inspect all components of the coupling equipment on the towing vehicle and the generator set for defects such as excessive wear, corrosion, cracks, bent metal, or loose bolts. Ensure that the towing vehicle is rated for towing a load of at least the weight of the mobile generator set plus a 10% safety factor.

Couple the towing vehicle to the trailer and ensure the coupling device is engaged, closed and locked. Attach

electrical connector for indicator lights, etc. Attach chains, if provided, by crossing them under the drawbar and attaching to the towing vehicle. Attach any "break away" safety wire, if fitted.

Fully retract the front screw jack, if equipped, and secure with the pin or locking device. Lock the front castor wheel, if equipped, in the full up position. Ensure that the rear stabilizer jacks, if equipped, are raised and locked.

Inspect tyres for condition and proper inflation. Check all tail lights, if equipped, are operating properly and that all reflectors are clean and functional.

Ensure load and grounding/earthing cables are disconnected and that all windows, access doors, and tool box covers are closed, latched and locked. Ensure any external fuel pipes are disconnected.

Release trailer parking brakes, if equipped, and remove any blocks or chocks under the wheels.

4.14.2 Towing: Whenever towing a mobile generator set, remember that the set may approach or exceed the weight of the towing vehicle so maneuverability and stopping distance will be affected.

WARNING:

- ! **When towing a mobile generator set, observe all Codes, Standards or other regulations and traffic laws. These include those regulations specifying required equipment and maximum and minimum speeds.**
- ! **Ensure brakes, if fitted, are in good order.**
- ! **Do not permit personnel to ride in or on the mobile generator set. Do not permit personnel to stand or ride on the drawbar or to stand or walk between the generator set and the towing vehicle.**

Avoid gradients in excess of 15° (27%) and avoid potholes, rocks or other obstructions and soft or unstable terrain.

Ensure the area behind and under the mobile set is clear before reversing.

4.14.3 Parking: Park the set on a dry level area that can support its weight. If it must be located on a slope, park it across the grade so that it does not tend to roll downhill. Do not park the set on grades exceeding 15° (27%).

Set the parking brake and block or chock both sides of all wheels. Lower front screw jack, castor wheel and/or rear stabilizer jacks, as fitted.

Unhook chains, if equipped, from the towing vehicle, disconnect electrical connection, disconnect the coupling device and move the towing vehicle clear of the mobile generator set.

4.15 Storage

Long term storage can have detrimental effects on both the engine and alternator. These effects can be minimized by properly preparing and storing the generator set.

4.15.1 Engine Storage: The engine should be put through an engine "preservation" procedure that includes cleaning the engine and replacing all the fluids with new or preserving fluids. See the Engine Manual for the proper procedure.

4.15.2 Alternator Storage: When an alternator is in storage, moisture tends to condense in the windings. To minimize condensation, store the generator set in a dry storage area. If possible use space heaters to keep the windings dry.

After removing the generator set from storage, perform an insulation check as discussed in Section 4.12.8. If the readings are lower than prior to storage, it may be necessary to dry out the windings. See the Alternator Manual for procedures.

If the megger reading is below 1MΩ after drying, the insulation has deteriorated and should be reconditioned.

4.15.3 Battery Storage: While the battery is stored, it should receive a refreshing charge every 12 weeks (8 weeks in a tropical climate) up to a fully charged condition.

5. OPERATION

5.1 General

The generator set is equipped with an advanced electronic control system. This will be one of a range of systems such as a 1001, 2001, 4001 or 4001E control system. See Section 9 of this manual to identify which system is fitted on the generator set and for a functional description of each.

These control systems allow the operator to manually or automatically control the generator set. They have protection circuits to sound an optional alarm and even shutdown the set if problems occur. Details of the capabilities of each system are contained in Section 9.

The following procedures detail the steps required to prepare the set for operation, start and stop it for the first time after installation, and start and stop it normally. Section 5.2, Pre-Start Checks are applicable with all control systems. Section 5.3 and 5.4 cover operation of the Keystart Control Systems (1001 Series). Section 5.5, 5.6 and 5.7 cover operation of the Autostart Control Systems (2001, 4001 and 4001E Series).

5.2 Pre-Start Checks (applicable to all control systems)

The following checks should be performed prior to starting the generator set:

WARNING:

- ! For generator sets in walk-in type enclosures ensure that all vibration isolator restraints are removed before starting the generator set.
- ! As generator sets with autostart control panels (2001 Series or above) can be remotely started without warning, always ensure the control panel is switched off before carrying out any checks.

1. Ensure the Control Switch/Key Switch is Off.

WARNING:

- ! Do not remove the radiator cap when the coolant is hot. Do not add large amounts of cold coolant to a hot system as serious damage could result.

2. Check the engine oil and coolant levels - replenish as necessary.

Note:

- Diesel engines normally consume lube oil at a rate of .25% to 1% of the fuel consumption.
- When adding coolant to the radiator system, always pour slowly to help prevent air from becoming trapped in the engine.

WARNING:

- ! When filling the fuel tank, do not smoke or use an open flame in the vicinity.

3. Check the fuel level - fill as necessary.

WARNING:

- ! Before tightening fan belts, disconnect the battery negative (-) lead to ensure the engine cannot be accidentally started.

4. Check the condition and tension of the fan and engine alternator belts - tighten as necessary.
5. Check all hoses for loose connections or deterioration - tighten or replace as necessary.
6. Check the battery terminals for corrosion - clean as necessary.

WARNING:

- ! When working with the batteries, do not smoke or use an open flame in the vicinity. Hydrogen gas from batteries is explosive.

- ! Do not short the positive and negative terminals together.

7. Check the battery electrolyte level - fill with distilled water as necessary. If the battery is new and has never been wet charged, fill with suitable premixed electrolyte and charge as per instructions in Section 10.2.2.
8. Check the control panel and the generator set for heavy accumulation of dust and dirt - clean as necessary. These can pose an electrical hazard or give rise to cooling problems.
9. Check the air filter restriction indicator, if fitted - replace the filter as necessary.
10. Clear the area around the generator set of any insecure items that could inhibit operation or cause injury. Ensure cooling air ventilation screens are clear.
11. Visually check the entire generator set for signs of leaks from the fuel system, cooling system or lubrication seals.
12. Periodically drain exhaust system condensate traps, if equipped.
13. Ensure the Alternator Output Circuit Breaker is in the "OFF" (handle down) position.

5.3 Initial Startup/Shutdown - Key Start Panel (1001 Series)

The following procedure should be used when starting a generator set equipped with a 1001 Series Key Start Control System for the first time or when it has been out of service for a time for maintenance purposes:

Note:

- The generator set may be stopped at any time by pressing the Emergency Stop button or by turning the Key Switch to Position "O" (Off).

1. Complete Pre-Start checks as per Section 5.2.
2. Connect the batteries to the engine, positive lead first then the negative lead.
3. Prime the lube oil system by first removing one wire from the fuel solenoid or actuator. This prevents the engine from starting. Then crank the engine by turning the Key Switch to Position "S" (Start) for 5 to 7 seconds. Return the Key Switch to Position "O" (Off). Repeat the cranking attempt up to 4 times, if required, until oil pressure is registered on the gauge. Should the oil pressure still not have built up after 4 cranking attempts, investigate the reason for lack of oil pressure prior to further cranking. Reconnect the wire to the fuel solenoid or actuator.

WARNING:

- ! Excessive cranking with an unprimed fuel system may cause a build-up of unburned fuel gases in the exhaust system which could be potentially explosive.

4. Prime the fuel system using the hand priming pump and bleed entrapped air from the fuel filter - see Engine Manual for details.
5. **Start:** Turn the Key Switch from Position "O" (Off) through Position "I" (On) to Position "T" (Thermo) to activate the thermostart, if fitted. Hold for 7 seconds to preheat the induction air. After this time, the Key Switch should be further turned to Position "S" (Start) to crank the engine. When the engine starts, release the Key Switch immediately allowing it to return to Position "I" (On).

Do not crank the engine for more than 5 to 7 seconds should the engine fail to start. Allow an interval of 10 seconds and always turn Key Switch to Position "O" (Off) between cranking attempts. If, after 4 cranking attempts, the engine still has not started, refer to the trouble shooting guide in Section 9 or the Engine Manual to determine the cause of failure to start.

WARNING:

! **Unburned fuel gases can build-up in the exhaust system after multiple failed attempted starts. Unscrew the plugs on the exhaust outlet elbows or stub pipes and allow the unburned fuel to dissipate. Once all signs of unburned fuel (white smoke) have disappeared and any other problems causing the failure to start have been rectified, replace the plugs and repeat the cranking procedure.**

WHEN ENGINE HAS STARTED

6. After approximately 1 minute shutdown the generator set by pressing the Emergency Stop or by turning the Key Switch to Position "O" (Off). Remove the radiator cap and wait 5 minutes for the system to settle and any trapped air to escape. Re-check the coolant level and refill as necessary.

Note:

- A newly filled coolant system can have air locks that must be cleared by running the engine for a short time and the system refilled prior to extended running of the engine.
7. Restart the engine following the procedure in step 5 above.
 8. Check for any abnormal noise or vibration.
 9. Check for fluid leakage or leaks in the exhaust system.
 10. Check the control panel for indications of abnormal operation, particularly abnormally high temperature or abnormally low oil pressure. The oil pressure should be in the normal range within about 10 seconds of starting.
 11. Check the control panel for output voltage and frequency. The voltage is factory set and should indicate the rated voltage. The **no load** frequency is approximately 52 Hz for 50 Hz units and approximately 62 Hz for 60 Hz units. Adjustments should only be carried out by a qualified technician.

Three means of voltage adjustment are available:-

Fine adjustment is achieved by varying the setting of the speed potentiometer on the control panel, if fitted.

Coarse adjustment is achieved by varying the setting of a potentiometer mounted inside the automatic voltage regulator which is fitted to the alternator terminal box.

Gross adjustment to completely change the voltage setting of the alternator is achieved by reconnecting the alternator windings at the alternator terminal box. Details of these connections can be found in the Alternator Manual.

WARNING:

! **Do not close the circuit breaker during the phase rotation check if load cables have already been connected.**

12. While the generator set is producing voltage, check the phase rotation of the set by connecting a phase rotation meter to the terminals on the generator side of the circuit breaker. This check should be carried out by a qualified technician.
13. **Shutdown:** To shutdown the generator set press the Emergency Stop button or turn the Key Switch to Position "O" (Off).

WARNING:

! **Always switch off the circuit breaker, shut down the generator set and disconnect the battery negative (-) lead prior to connection or disconnection of the load cables.**

14. The load cables can now be connected to the generator set in preparation for normal operation.

5.4 Normal Startup/Shutdown - Key Start Panel (1001 Series)

The following procedure should be used for subsequent starts on a generator set equipped with a 1001 Series Key Start Control System:

Note:

- The generator set may be stopped at any time by pressing the Emergency Stop button or by turning the Key Switch to Position "O" (Off).

- Prior to restarting the set, the Emergency Stop Pushbutton must be released by turning it clockwise.

1. Complete Pre-Start checks as per Section 5.2.
2. Check the battery voltage by turning the Key Switch from Position "O" (Off) to Position "I" (On) and reading the battery voltmeter. A fully charged battery will indicate 12 to 14 volts on a 12 volt system or 24 to 28 volts on a 24 volt system. Return the Key Switch to Position "O" (Off).

Note:

- The engine will not start if any fault indicators are illuminated. Reset the control system by turning the Key Switch to Position "O" (Off). Ensure the faults have been corrected prior to attempting to start the generator set.

WARNING:

! **The Key Switch must not be turned to position "0000" or position "☞", while the engine is running.**

3. **Start:** Turn the Key Switch from Position "O" (Off) through Position "I" (On) to Position "☞" (Thermo) to activate the thermostart, if fitted. Hold for 7 seconds to preheat the induction air. After this time, the Key Switch should be further turned to Position "☞" (Start) to crank the engine. When the engine starts, release the Key Switch immediately allowing it to return to Position "I" (On).

Do not crank the engine for more than 5 to 7 seconds should the engine fail to start. Allow an interval of 10 seconds and always turn the Key Switch to Position "O" (Off) between cranking attempts. If, after 4 cranking attempts, the engine still has not started, refer to the trouble shooting guide in Section 9 or the Engine Manual to determine the cause of failure to start.

WARNING:

! **Unburned fuel gases can build-up in the exhaust system after multiple failed attempted starts. Unscrew the plugs on the exhaust outlet elbows or stub pipes and allow the unburned fuel to dissipate. Once all signs of unburned fuel (white smoke) have disappeared and any other problems causing the failure to start have been rectified, replace the plugs and repeat the cranking procedure.**

WHEN ENGINE HAS STARTED

4. Check for any abnormal noise or vibration.
5. Check for fluid leakage or leaks in the exhaust system.
6. Check the control panel for indications of abnormal operation, particularly abnormally high temperature or abnormally low oil pressure. The oil pressure should be in the normal range within about 10 seconds of starting.
7. Switch the Alternator Output Circuit Breaker to "ON" (handle up).

Note:

- Load can now be applied to the generator set. However

the maximum step load that can be accepted in any one step is dependent on the operating temperature of the set. With the generator cold (not more than 20°C (68°F)) the maximum step load acceptance is approximately 50% of rated output. However with the set at normal operating temperature (approximately 80°C (176°F)) the maximum step load can be 70-100% of the rated load depending on the generator set model. Typically generator sets up to 100 kVA can accept a 100% load.

8. **Shutdown:** To shut the generator set down, turn off the load by switching the Alternator Output Circuit Breaker to "OFF" (handle down). Allow the generator set to run without load for a few minutes to cool. Then turn the Key Switch to Position "O" (Off). The generator set will shutdown.

In case of an emergency where immediate shutdown is necessary, push the Emergency Stop button or turn the Key Switch to Position "O" (Off) immediately without disconnecting the load.

Note:

- Turning the Key Switch to Position "O" (Off) will also reset the protective circuits after a fault has been detected. Ensure that the fault has been rectified prior to restarting the generator set.

5.5 Initial Startup/Shutdown - Autostart Panel (2001, 4001, or 4001E Series)

The following procedure should be used when manually starting a generator set equipped with a 2001, 4001 or 4001E Series Autostart Control System for the first time or when it has been out of service for a time for maintenance purposes:

Note:

- The generator set may be stopped at any time by pressing the Emergency Stop Pushbutton or turning the Control Switch to "STOP".
 - Prior to restarting the set, the Emergency Stop Pushbutton must be released by turning it clockwise. The fault lamp must also be reset by turning the Control Switch to "STOP" for the 2001 panel or by pressing the P.C.B RESET button on the 4001 and 4001E panels.
1. Complete Pre-Start checks as per Section 5.2.
 2. Connect the batteries to the engine, positive lead first then the negative lead.
 3. Prime the lube oil system by first removing one wire from the fuel solenoid or actuator. This prevents the engine from starting. Turn the Control Switch to "RUN". The engine will automatically crank. When oil pressure is registered on the gauge, turn the Control Switch back to "OFF" and reconnect the wire to the fuel solenoid or actuator. Should the oil pressure still not have built up after 3 automatic cranking attempts and illumination of the "FAIL TO START" fault lamp, investigate the reason for lack of oil pressure prior to further cranking attempts.

WARNING:

! **Excessive cranking with an unprimed fuel system may cause a build-up of unburned fuel gases in the exhaust system which could be potentially explosive.**

4. Prime the fuel system using the hand priming pump and bleed entrapped air from the fuel filter - see Engine Manual for details.
5. **Start:** Ensure the Emergency Stop Pushbutton and any remote Stop Pushbuttons are released. Turn the Control Switch to "RUN". If the engine is cold, prior to turning the Control Switch to "RUN" push in the thermostart button, if fitted, for 15 seconds and then turn the Control Switch to "RUN". Continue holding the thermostart button in until the engine fires.

The engine will automatically crank up to 3 times or until the engine fires. If the engine does not fire, the control

system locks-out on "FAIL TO START" and illuminates a fault lamp on the control panel. If this happens refer to the trouble shooting guide in Section 9 or the Engine Manual to determine the cause of failure to start.

WARNING:

! **Unburned fuel gases can build-up in the exhaust system after multiple failed attempted starts. Unscrew the plugs on the exhaust outlet elbows or stub pipes and allow the unburned fuel to dissipate. Once all signs of unburned fuel (white smoke) have disappeared and any other problems causing the failure to start have been rectified, replace the plugs and repeat the cranking procedure.**

WHEN ENGINE HAS STARTED

6. After approximately 1 minute shutdown the generator set by pressing the Emergency Stop Pushbutton or by turning the Control Switch to "STOP". Remove the radiator cap and wait 5 minutes for the system to settle and any trapped air to escape. Re-check the coolant level and refill as necessary.

Note:

- A newly filled coolant system can have air locks that must be cleared by running the engine for a short time and the system refilled prior to extended running of the engine.
7. Restart the engine following the procedures in step 5 above.
 8. Check for any abnormal noise or vibration.
 9. Check for fluid leakage or leaks in the exhaust system.
 10. Check the control panel for indications of abnormal operation, particularly abnormally high temperature or abnormally low oil pressure. The oil pressure should be in the normal range within about 10 seconds of starting.
 11. Check the control panel for output voltage and frequency. The voltage is factory set and should indicate the rated voltage. The **no load** frequency is approximately 52 Hz for 50 Hz units and approximately 62 Hz for 60 Hz units. Adjustments should only be carried out by a qualified technician.

Three means of voltage adjustment are available:-

Fine adjustment is achieved by varying the setting of a speed Potentiometer on the control panel, if fitted.

Coarse adjustment is achieved by varying the setting of a Potentiometer mounted inside the automatic voltage regulator which is fitted to the alternator terminal box.

Gross adjustment to completely change the voltage setting of the alternator is achieved by reconnecting the alternator windings at the alternator terminal box. Details of these connections can be found in the Alternator Manual.

WARNING:

! **Do not close the circuit breaker during the phase rotation check if load cables have already been connected.**

12. While the generator set is producing voltage, check the phase rotation of the set by connecting a phase rotation meter to the terminals on the generator side of the circuit breaker. This check should be carried out by a qualified technician.
13. **Shutdown:** To shutdown the generator set press the Emergency Stop Pushbutton or turn the Control Switch to "STOP".
14. To check any remote start facilities ensure the Emergency Stop Pushbutton and any remote Stop Pushbuttons are released and turn the Control Switch to "AUTO".

Apply the remote start signal and the engine should

automatically go through its startup sequence as previously described. Remove the remote start signal and the engine should stop.

Note:

- On 4001 and 4001E Series Control System a Run On Timer will allow the set to run for a short duration to cool prior to stopping automatically.

To shutdown the generator set remove the remote start signal, press the Emergency Stop Pushbutton or turn the Control Switch to "STOP".

WARNING:

- ! **Always switch off the circuit breaker, shut down the generator set and disconnect the battery negative (-) lead prior to connection or disconnection of the load cables.**

15. The load cables can now be connected to the generator set in preparation for normal operation.

5.6 Normal Manual Startup/Shutdown - Autostart Panel (2001, 4001 or 4001E Series)

The following procedure should be used for subsequent manual starts on a generator set equipped with a 2001, 4001 or 4001E Series Autostart Control System:

Note:

- The generator set may be stopped at any time by pressing the Emergency Stop Pushbutton or turning the Control Switch to "STOP".
- Prior to restarting the set, the Emergency Stop Pushbutton must be released by turning it clockwise. The fault lamp must also be reset by turning the Control Switch to "STOP" for the 2001 panel or by pressing the P.C.B RESET button on the 4001 and 4001E panels.

1. Complete Pre-Start checks as per Section 5.2.

Note:

- The engine will not start if any fault indicators are illuminated. Reset the control system by turning the Control Switch to "STOP". Ensure the faults have been corrected prior to attempting to start the generator set.

2. **Manual Start:** Ensure the Emergency Stop Pushbutton and any remote Stop Pushbuttons are released. Turn the Control Switch to "RUN". If the engine is cold, prior to turning the Control Switch to "RUN" push in the thermostart button, if fitted, for 15 seconds and then turn the Control Switch to "RUN". Continue holding the thermostart button in until the engine fires.

The engine will automatically crank up to 3 times or until the engine fires. If the engine does not fire, the control system locks-out on "FAIL TO START" and illuminates a fault lamp on the control panel. If this happens refer to the trouble shooting guide in Section 9 or the Engine Manual to determine the cause of failure to start.

WARNING:

- ! **Unburned fuel gases can build-up in the exhaust system after multiple failed attempted starts. Unscrew the plugs on the exhaust outlet elbows or stub pipes and allow the unburned fuel to dissipate. Once all signs of unburned fuel (white smoke) have disappeared and any other problems causing the failure to start have been rectified, replace the plugs and repeat the cranking procedure.**

WHEN ENGINE HAS STARTED

3. Check for any abnormal noise or vibration.
4. Check for fluid leakage or leaks in the exhaust system.
5. Check the control panel for indications of abnormal operation, particularly abnormally high temperature or abnormally low oil pressure. The oil pressure should be in the normal range within about 10 seconds of starting.

6. Switch the Alternator Output Circuit Breaker to "ON" (handle up).

Note:

- Load can now be applied to the generator set. However the maximum step load that can be accepted in any one step is dependent on the operating temperature of the set. With the generator cold (not more than 20°C (68°F)) the maximum step load acceptance is approximately 50% of rated output. However with the set at normal operating temperature (approximately 80°C (176°F)) the maximum step load can be 70-100% of the rated power depending on the generator set model. Typically generator sets up to 100 kVA can accept a 100% load.

7. **Shutdown:** To shut the generator set down, turn off the load by switching the Alternator Output Circuit Breaker to "OFF" (handle down). Allow the generator set to run without load for a few minutes to cool. Then turn the Control Switch to "STOP". The generator set will shutdown.

In case of an emergency where immediate shutdown is necessary, the Emergency Stop Pushbutton should be pushed immediately without disconnecting the load.

5.7 Automatic Startup/Shutdown - Autostart Panel (2001, 4001 or 4001E Series)

The following procedure should be used for preparing a generator set equipped with a 2001, 4001 or 4001E Series Autostart Control System to be started from a remote location.

Note:

- The generator set may be stopped at any time by pressing the Emergency Stop Pushbutton or turning the Control Switch to "STOP".
- Prior to restarting the set, the Emergency Stop Pushbutton must be released by turning it clockwise. The fault lamp must also be reset by turning the Control Switch to "STOP" on the 2001 panel or by pressing the P.C.B RESET button on the 4001 and 4001E panels.

1. Complete Pre-Start checks as per Section 5.2.

Note:

- The engine will not be able to start if any fault indicators are illuminated. Reset the control system by turning the Control Switch to "STOP" on the 2001 panel or by pressing the P.C.B RESET button on the 4001 and 4001E panels.

Ensure the faults have been corrected prior to attempting to start the generator set.

2. **Automatic Start:** Ensure the Emergency Stop Pushbutton and any remote Stop Pushbuttons are released. Turn the Control Switch to "AUTO".
3. Switch the Alternator Output Circuit Breaker to "ON" (handle up).

The generator set is now ready to automatically start when it receives a remote start signal. When the start signal is removed it will automatically stop.

Note:

- On 4001 and 4001E Series Control Systems a Run On Timer will allow the set to run for a short duration to cool prior to stopping automatically.

6. GENERATOR SET MAINTENANCE

6.1 General

A good maintenance program is the key to long generator set life. Maintenance and service should only be carried out by qualified technicians. Records of this work should be kept to aid in developing an efficient maintenance program.

In general, the generator set should be kept clean. Do not permit liquids such as fuel or oil film to accumulate on any internal or external surfaces or on, under or around any

acoustic material, if fitted. Wipe down surfaces using an aqueous industrial cleaner. Do not use flammable solvents for cleaning purposes.

Any acoustic material with a protective covering that has been torn or punctured should be replaced immediately to prevent accumulation of liquids or oil film within the material.

6.2 Preventative Maintenance

Depending on the application of the generator set, requirement for preventative maintenance will vary. The preventative maintenance requirements associated with the engine are detailed in the Engine Manual which should be reviewed in conjunction with this section. Maintenance intervals for the engine may be more frequent than those shown in this section.

6.2.1 Daily or at Each Startup: (For standby sets these procedures may be performed weekly.) A walk around inspection should be performed on a daily basis and prior to starting the engine. The pre-start checks contained in Section 5.2 should be performed during this walk around. Procedures for performing the checks on the engine can be found in the Engine Manual which may contain additional requirements to those in Section 5.2.

6.2.2 Every Two Weeks: (For standby sets that have not been run.) Perform an operational check on the generator set by starting and running the set for only 5 minutes.

WARNING:

! Do not run diesel engines at low loads for long periods.

6.2.3 Every Month: (For standby sets that have not been run on load.) Perform an operational and load check on the generator set by starting and running the set on at least 50% load for 1 to 2 hours.

6.2.4 Every Six Months or 250 Hours: Repeat the daily procedures plus the following:

1. Check all control system safety devices by electrically simulating faults.
2. Clean all battery cap vents.
3. Tighten all exhaust connections.
4. Tighten all electrical connections.
5. Perform other engine maintenance as specified in the Engine Manual.
6. Start the engine and observe the instrument panel to ensure that all gauges and meters are operating properly.
7. If a spark arrestor has been fitted, this should be removed and thoroughly cleaned to remove any carbon build-up.

6.2.5 Alternator Preventative Maintenance: There is no routine maintenance required on the alternator, however periodic inspection of the alternator winding condition and periodic cleaning is recommended. See Section 8.2, Alternator Maintenance, and the Alternator Manual.

6.2.6 Engine Preventative Maintenance: See the Engine Manual provided with this manual for information on regular maintenance required to keep the engine operating efficiently.

6.3 Removal of Engine and/or Alternator

The following procedures should be used for removal of the engine and/or alternator.

1. Isolate and disconnect electrical power supply to auxiliary equipment such as a water heater.

2. Isolate the battery charger supply. Disconnect the battery (negative lead first) and remove if necessary.
3. If the generator set is equipped with a canopy, remove the fixing bolts on each side, disconnect the exhaust system and then remove the canopy.
4. Isolate and disconnect the control panel and remove together with stand from the generator set, ensuring that all cables have been adequately identified to facilitate reconnection.
5. If the engine and alternator are both to be removed, they may be lifted out as one unit using the lifting eyes provided on **both** the engine and alternator. First the bolts holding the engine/alternator to the baseframe have to be removed.

6.3.1 Engine Removal Only:

1. If only the engine is to be removed, the wiring loom should first be removed from the engine.
2. If the alternator is fitted with only one set of feet then the front end of the alternator will have to be firmly supported before removing the engine.
3. Remove the bolts holding the engine to the base. It may also be advantageous to loosen the alternator mounting bolts.
4. Remove the alternator fan guards.
5. Support the rotor assembly using a sling or wooden supports taking care not to damage the fan.
6. Remove the bolts between the flexible coupling and the engine flywheel.
7. Support the rear of the engine using an overhead crane or similar device.
8. Remove the coupling housing bolts.
9. The engine is now moved forward until it is clear of the alternator and may be lifted away from the base.

6.3.2 Alternator Removal Only:

1. If the alternator only is to be removed, the rear of the engine must be firmly supported.
2. Remove the wiring loom.
3. Remove the bolts holding the alternator to the baseframe. Loosen the engine bolts as well.
4. Remove the alternator fan covers and support the rotor and the front of the alternator. Ensure that the rotor is positioned with a pole at the bottom center line. This is to avoid any damage to the bearing or exciter by limiting the rotor movement to that of the air gap.
5. Uncouple the alternator from the engine as per Section 6.3.1.
6. Support the alternator using a sling or similar device and slide the complete alternator back on the base before lifting.

7. ENGINE DESCRIPTION AND MAINTENANCE

7.1 Engine Description

7.1.1 General: The engine that powers the generator set is an industrial, heavy duty diesel engine that has been selected for its reliability and efficiency in operation. It is specifically designed and optimized to power generator sets. The engine is either a 4 stroke or 2 stroke compression ignition type with all the accessories necessary to provide a reliable power supply. Full details of the engine and associated equipment is provided in the Engine Manual. This section gives a brief discussion of the major systems and how they are integrated into the generator set.

If regular preventative maintenance is performed as per the Engine Manual, the diesel engine will continue to provide reliable power for many years.

7.1.2 Cooling System: The engine cooling system is comprised of a radiator, high capacity pusher fan, a mechanically driven water pump and a thermostat. The fan is a pusher type that pushes the air through the radiator. This system provides for cooling of the surface heat of the engine and alternator, and internal cooling of the engine by the water circulating in the radiator. The alternator also has an integral fan that circulates cool air inside the housing. The thermostat maintains coolant temperature at a level for efficient operation of the engine.

It is important to pay careful attention to air flow around the generator set to ensure proper cooling. Following the installation instructions in Section 4.7 should ensure satisfactory performance.

7.1.3 Engine Governing: The engine governor is either a mechanical or electronic device designed to maintain a constant engine speed in relation to load requirements. The engine speed is directly related to the frequency of the alternator output, so any variation in engine speed will effect the frequency of the power output.

The governor senses engine speed and controls the fuel rate. As load increases on the alternator the governor will increase fuel flow to the engine. As load is reduced the governor reduces fuel flow.

7.1.4 Fuel System: On most generator sets, the engine fuel system is connected directly to a fuel tank that is built into the baseframe. This tank is designed to provide sufficient fuel for approximately 8 hours operation at full load unless an extended capacity tank has been fitted. In this case approximately 24 hours operation is possible.

The basetank is provided with fittings to facilitate either manual or automatic filling from a larger bulk storage tank. See Section 4.9 for a discussion of the entire fuel system.

On larger sets, the baseframe does not include a fuel tank so the engine fuel system must be connected to a separate tank located next to the set.

7.1.5 Exhaust System: Exhaust systems are provided to reduce the noise level of the engine and to direct the exhaust gases to where they will not be a hazard.

On smaller sets the exhaust silencer and piping are mounted directly on the engine. On larger engines the exhaust system is supplied loose for installation on site.

7.1.6 Air Flap Valve: An air flap valve, if fitted, prevents overspeeds due to ingestion of gas or fumes by cutting off the air supply. Functional testing of these combustion air intake valves should not be performed on engines on load. A functional test should only be carried out when the engine is not running. If it is necessary to demonstrate air valves closing when the engine is running this should be done at no load. The engine should absolutely **not** be restarted immediately afterwards.

WARNING:

! **The closing of the air flap valve while the engine is running can cause oil carry over into the exhaust system which is highly volatile. The engine should be left for a period of time to allow these gases to dissipate.**

7.1.7 Starting Aids: Ethyl Ether starting aids are not recommended. They will reduce the efficient working life of the engine.

7.2 Engine Maintenance

The Engine Manual supplied with this manual contains detailed information on maintaining the engine. It also includes a comprehensive Trouble Shooting guide for engine faults.

7.3 Radiator Maintenance

7.3.1 General Notes: Corrosion in the radiator can be a prime cause of failure. This is prompted by air in the water. Always ensure pipe connections are free of leaks and bleed air from top of the radiator regularly to keep the system "air free".

Radiators should not be left standing in a partially filled condition. Radiators left partly filled with water will suffer much more rapidly from the effects of corrosion. For an inoperative generator set, either drain the radiator completely or ensure that it is maintained full. Wherever possible, radiators should be filled with distilled or naturally soft water, dosed with suitable corrosion inhibitors.

WARNING:

! **Radiator coolant is normally very hot and under pressure. Do not work on the radiator or disconnect pipework until it has cooled. Do not work on the radiator or remove any guarding while the fan is in motion.**

7.3.2 External Cleaning: In dusty or dirty conditions the radiator fins can become blocked with loose debris, insects, etc. and this fouling will have an effect on the performance of the radiator.

For regular removal of light deposits use a low pressure steam jet. More difficult deposits may need a detergent with a low pressure hot water hose. Spray steam jet or water from the front of the radiator towards the fan. Spraying in the opposite direction will force debris further into the core. Covering the engine/alternator during this process will keep them clean.

Stubborn deposits, which cannot be removed by the above methods may require removal of the radiator and immersion in a heated alkali degreasing solution for about 20 minutes and then washing off with a hot water hose.

7.3.3 Internal Cleaning: If, due to leaky joints for instance, indiscriminate topping-up with hard water has been carried out for some time, or if the generator set has been run without inhibitors the system may become fouled by scale.

To descale the radiator, use the following procedure:

1. Drain the water system and disconnect and blank off the pipe connections to the engine.
2. Prepare a 4% solution of inhibited acid solvent and fresh water. Add the acid to the water, never vice versa.
3. Allow several minutes for mixing, then heat the solution to 49°C (120°F) maximum.
4. Run the solution slowly into the radiator via the filler cap or a branch in the manifold. Effervescence will occur. When it ceases, fill the radiator completely with the heated solvent.
5. Allow to stand for several minutes; then drain the solvent back into the original container through the bottom

manifold or drain plug.

6. Examine the interior of the headers. If scale remains repeat the process outlined above with the solvent strength increased to 8%.
7. After descaling the acid solution has to be neutralized as follows:-

Fill the mixing container with fresh water, heat to boiling point then add common washing soda crystals at the following strength: 0.5 kg of soda to 20 liters water (1 lb. soda to 4 gallons water). Fill the radiator with this solution, then drain it back into the container.
8. Flush the radiator in this manner several times, finally leaving the radiator full for at least an hour. Drain until empty and wash out the radiator with hot fresh water.
9. Before putting the radiator into service again, fill with water and apply a test pressure equal to twice that of the working pressure. Examine carefully for any leaks which may have been revealed by descaling.
10. Prior to recommissioning, the coolant must have any necessary corrosion inhibitors and/or the correct proportion of antifreeze added.

8. ALTERNATOR DESCRIPTION AND MAINTENANCE

8.1 Alternator Description

8.1.1 General: The alternator fitted on the generator set is of the brushless self-excitation type which eliminates the maintenance associated with slip rings and brushes. The control system consists of an automatic voltage regulator, protective circuits and the necessary instruments to allow monitoring of the output of the generator set.

8.1.2 Construction/Major Components: The alternator unit is completely self-contained and is designed and constructed to provide trouble free operation, ease of maintenance and long service life.

The stator core is produced from insulated low loss electrical grade sheet steel laminations. These are built and welded under a fixed pressure to give an extremely rigid core to withstand vibrations and load impulses. The complete wound stator is, after impregnation, pressed into the frame and pinned into position.

A high grade precision machined shaft carries the rotor assembly which comprises the alternator rotating field systems, the exciter rotor/rotating diode system and the cooling fan. The rotor is mechanically wedged and supported on the winding end to allow an overspeed of up to 2250 RPM. The complete rotor assembly is dynamically balanced to ensure vibration-free running.

At the drive end of the rotor assembly a cast-aluminum centrifugal fan draws cooling air through screened/louvered covers at the non drive end and discharges it through similar side mounted covers at the drive end.

8.1.3 Alternator Method of Operation: The electrical power produced by the generator set is derived from a closed loop system consisting principally of the exciter rotor, the main revolving field and the automatic voltage regulator (See Figure 8.1).

The process begins when the engine starts to rotate the internal components of the alternator. The residual magnetism in the main rotor (item 1) produces a small alternating voltage (AC) in the main stator (item 2). The automatic voltage regulator (item 3) rectifies this voltage (converts it to DC) and applies it to the exciter stator (item 4).

This DC current to the exciter stator creates a magnetic field which, in turn, induces an AC voltage in the exciter rotor (item 5). This AC voltage is converted back to DC by the rotating diodes (item 6).

When this DC voltage appears at the main rotor, a stronger magnetic field than the original residual field is created which induces a higher voltage in the main stator.

This higher voltage circulates through the system inducing an even higher DC voltage back at the main rotor. This cycle continues to build up the voltage until it approaches the proper output level of the generator set. At this point the automatic voltage regulator begins to limit the voltage being passed to the exciter stator which, in turn, limits the overall power output (item 7) of the alternator.

This build-up process takes place in less than one second.

8.1.4 Automatic Voltage Regulator: The Automatic Voltage Regulator (AVR) maintains a no load to full load steady state voltage to tight tolerances. The AVR has a volts/hertz characteristic which proportionally reduces the regulated voltage at reduced speeds. This feature aids the engine during sudden large additions of load.

8.2 Alternator Maintenance

Although maintenance is rarely required, periodic inspection and cleaning is recommended.

Perform a winding insulation test according to procedures provided in the Alternator Manual before the initial start, after generator set storage, and every 3 to 6 months depending on humidity levels (more often in higher humidity). In high humidity areas, installing space heaters to operate when the generator set is not running will help keep the windings dry.

The alternator air filters, if fitted, should be inspected regularly depending on site conditions. If cleaning is necessary, remove the filter elements from the filter frames. Immerse or flush the element with a suitable detergent agent until the element is clean. Dry the elements thoroughly before refitting.

Additionally the alternator unit should be cleaned on a regular basis. The frequency of such cleanings depends on the environmental conditions of the operating site. The following procedure should be followed when cleaning is necessary: Disconnect all power. Wipe dust, dirt, oil, water and any other liquids from the external surfaces of the alternator unit and from the ventilation screens. These materials can work their way into the windings and may cause overheating or insulation breakdown. Dust and dirt is best removed using a vacuum cleaner. Do not use compressed air, steam or high pressure water!

The separate Alternator Manual provided with this manual contains more detailed information on alternator maintenance. It also includes a trouble shooting guide for alternator faults.

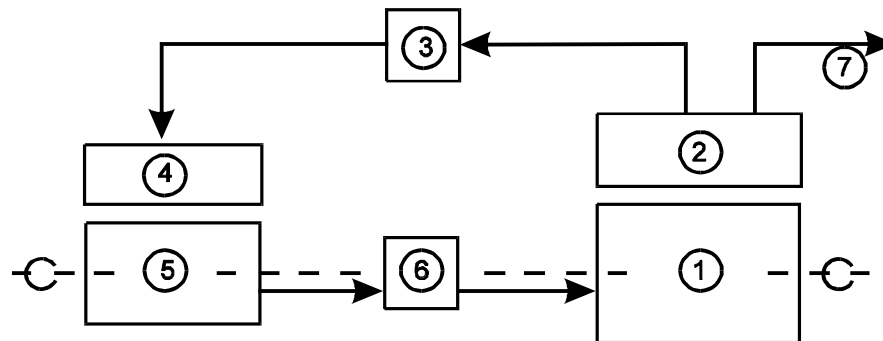

Item	Description	Item	Description
1.	Main Rotor	5.	Exciter Rotor
2.	Main Stator	6.	Rotating Diodes
3.	Automatic Voltage Regulator	7.	Power Output
4.	Exciter Stator		

Figure 8.1: Block Diagram of Alternator Operation

9. CONTROL SYSTEM DESCRIPTION AND TROUBLE SHOOTING

9.1 Control System Description and Identification

9.1.1 Description: An advanced electronic control system has been designed and installed to control and monitor the generator set. Depending on the requirements of the set, one of several different standard control systems may be fitted. These include the 1001 Series Keystart System, 2001 Series Autostart System, 4001 Series Deluxe Autostart System and the 4001E Series Enhanced Deluxe Autostart System. Other more specialized systems may be installed for specific installations in which case separate documentation is provided.

These control systems consist of three major components working together - a control panel, an engine interface module (EIM), and an alternator output circuit breaker.

The control panel provides a means of starting and stopping the generator set, monitoring its operation and output, and automatically shutting down the set in the event of a critical condition arising such as low oil pressure or high engine coolant temperature. A 1001, 2001, 4001 or 4001E Series Panel is installed as appropriate for the requirements of the generator set installation.

The Engine Interface Module is a sealed, engine mounted module that provides switching relays for the Starter Motor Solenoid, Glow Plug and Fuel Solenoid. Each of these circuits is protected with individual fuses mounted in the module. Individual LED's illuminate when each circuit is energized. The Engine Interface Module is available in three models depending on the type of control panel being used - the 12 volt EIM SR, the 12 volt EIM Plus and the 24 volt EIM Plus. The table below indicates which EIM module is used on which generator sets:

Panel Fitted	Sets up to 150kVA (12 volt systems)	Sets above 150kVA (24 volt systems)
1001	12 Volt EIM SR	24 Volt EIM Plus
2001	12 Volt EIM Plus	24 Volt EIM Plus
4001	12 Volt EIM Plus	24 Volt EIM Plus
4001E	12 Volt EIM Plus	24 Volt EIM Plus

The power output circuit breaker serves to protect the alternator by automatically disconnecting the load in the event of overload or short circuit. It also provides a means of switching the generator set output.

9.1.2 Identification: Figure 9.1 shows each of the control panels to aid in identifying the system fitted on the generator set. The 1001 Series Panel, being a "Key Start" panel has a removable key to control the system. Only two fault lamps are provided on this panel. The 2001 Series Panel has a Control Switch, instead of a Key Switch, located below 5 fault lamps. The 4001 Series Panel is similar to the 2001 except the Control Switch is located below the gauges and there are 7 fault lamps. The 4001E Series Panel also has the Control Switch located below the gauges but has up to 16 fault lamps.

9.1.3 Panel Equipment: Before starting or running the generator set, the operator should become fully acquainted with the instruments and controls. The instruments should be observed from time to time while the generator set is running so that any abnormal readings can be detected before problems arise.

Figure 9.1 shows typical diagrams of each of the control panels. Addition of optional equipment will add items to the panel so the panel fitted on the generator set may be slightly different from the typical ones shown. The following descriptions explain the function of each item on the panels:

Item Description

1. AC VOLTMETER - A voltmeter that indicates the AC voltage generated at the alternator output terminals. The reading indicated on the voltmeter will vary depending on the connections made inside the alternator terminal box, the setting of the voltage regulator and the position of the voltmeter selector switch (item 2). It should not, however, vary while the set is operating. In the event of alternator excitation failing, the output voltage will fall to approximately 20 to 40 volts. If the meter gives no reading while the generator set is running, ensure that the AC voltmeter selector switch is not in the OFF position.
2. AC VOLTMETER SELECTOR SWITCH - A selector switch allowing the operator to select voltage reading between phases or between a phase and neutral. The OFF position allows the voltmeter "zero" position to be checked while the generator set is running.
3. AC AMMETER - An ammeter that indicates the AC electrical current being delivered which is dependent on the connected load. A separate reading from each of the phases is possible using the ammeter selection switch (item 4). If the meter gives no reading while the generator set is running, ensure that the AC ammeter selector switch is not in the OFF position.
4. AC AMMETER SELECTOR SWITCH - A selector switch allowing the operator to select a current reading from each of the phases. The OFF position allows the ammeter "zero" position to be checked while the generator set is running.
5. FREQUENCY METER - A meter that indicates the output frequency of the generator set. The engine maintains a relatively constant speed under governor control so as to provide the proper operating frequency of 50 Hz or 60 Hz when the generator set is operating at full rated load. At partial load the frequency will be slightly higher than normal, depending on the droop of the governor. In practice, no load frequencies of approximately 52 and 62 Hz for 50 Hz and 60 Hz respectively, are considered normal. The frequencies will fall, as the set is loaded, to 50 Hz and 60 Hz at full load.
6. HOURS RUN METER - A meter that indicates the total number of hours of generator set operation to aid in maintenance.
7. ENGINE WATER TEMPERATURE GAUGE - A temperature gauge connected to a sensor in the engine to monitor engine coolant temperature. The normal operating temperature should be approximately 85°C (185°F).
8. DC BATTERY VOLTMETER - A voltmeter that indicates the state of charge of the battery. When the engine is at standstill the normal battery voltage will be 12 to 14 volts on a 12 volt system and 24 to 28 volts on a 24 volt system. During starting, the needle will drop to about 70% of normal and oscillate as the engine cranks. Once the engine has started, the needle should return to its normal value. If the battery charging alternator is charging correctly, the voltage reading will always be higher with the generator set running than when it is stopped.
9. ENGINE OIL PRESSURE GAUGE - A gauge to monitor engine oil pressure from the moment the engine is cranked. The proper oil pressure rating should be approximately 35 to 60 p.s.i. for 50 Hz and 45 to 65 p.s.i. for 60 Hz. On cold engines the oil pressure will be significantly higher until the engine warms up.

Figure 9.1 Design of Typical Control Panels

10. **FAULT INDICATOR LAMPS** - Fault lamps that illuminate to indicate that the protective circuitry has sensed the indicated condition. The lamp should be red on conditions for which the system will initiate a shutdown of the set. For alarms, the lamp can be red or amber.
11. **LAMP TEST PUSHBUTTON** - A button to test the fault lamps and to reset an alarm warning lamp and circuitry after an alarm has been initiated.
12. **KEY SWITCH (1001 Series Only)** - A four position switch that provides a means of controlling or interrupting the battery supply to the control system, thermostart and starter motor.

Position "O" Off/Reset
Power is turned off and protection circuitry is reset in this position.

Position "I" On
DC power is supplied to the control system and the fault protection timer relay is initiated.

Position "⊙⊙⊙" Thermostart
DC power is supplied to the thermostart circuit, if fitted.

Position "🌀" Start
DC power is supplied to the starter motor to crank the engine. The thermostart circuit is also powered, if fitted.
13. **CONTROL SWITCH (2001, 4001 and 4001E Series Only)** - A three position switch that provides a means of controlling the generator set functions.

Position 1 "RUN"
The auto start function is initiated to immediately start and run the generator set.

Position 2 "STOP"
The generator set is shut down if running, and automatic start is inhibited. The fault protection circuitry is reset in this position.

Position 3 "AUTO"
The control circuitry is ready to initiate an automatic start upon receiving a remote start signal.

14. **EMERGENCY STOP PUSHBUTTON (1001,2001, 4001 and 4001E Series)** - A red lock-down pushbutton that immediately shuts down the generator set and will inhibit start until the pushbutton has been released by turning it clockwise. Prior to restarting the set, the fault lamp must be reset by turning the Control Switch to "STOP" for the 2001 panel or by pressing the P.C.B RESET button on the 4001 and 4001E panels.
15. **THERMOSTART PREHEAT BUTTON (2001, 4001 and 4001E Series Only)** - A button to power the thermostart preheat circuit, if fitted.

9.2 Functional Description 1001 Series Control System

The 1001 Series Control System provides for manual starting and stopping of the generator set and provides protection for the engine against both high engine coolant temperature and low oil pressure.

The control system is of the relay timer type based on a Printed Circuit Board (P.C.B.). The P.C.B. is off board fuse protected and controls the starting, stopping and fault protection of the engine. Figure 9.2 shows the layout of the 1001 Series P.C.B.

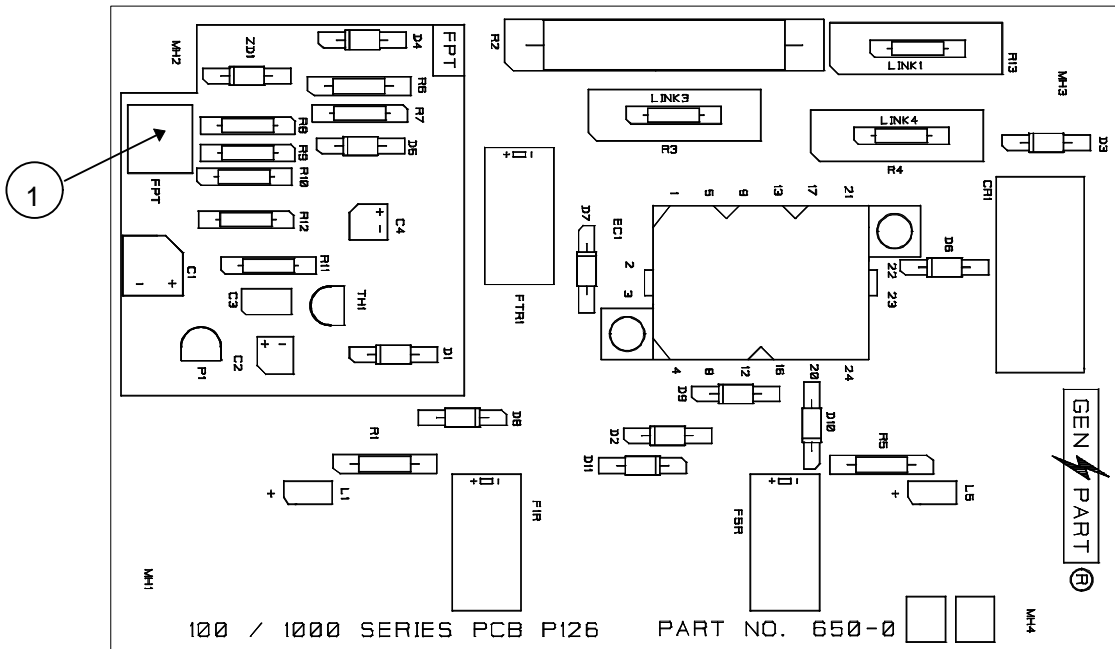

Item	Description
1.	FPT: Fault Protection Timer Adjust Range: 1-70 seconds Set: 15 ± 1 second

Figure 9.2: Layout of the 1001 Series P.C.B.

9.2.1 Function (1001 Series): Section 5 of this manual provides detailed guidance and checklists for the operation of the generator set. This section provides a more detailed description of the functions of the control system during operation.

During starting, turning the Key Switch from Position "O" (Off) to Position "I" (On) applies voltage to the P.C.B. and energizes Control Relay CR. With relay CR energized, contact CR/1 closes to energize the fuel control solenoid and the engine gauges.

WARNING:

! **The Key Switch must not be turned to position "⓪⓪⓪" (Thermo) or "🌀" (Start) while the engine is running.**

During start, turning the Key Switch through Position "I" (On) to Position "⓪⓪⓪" (Thermo) activates the thermostart, if fitted. This preheats the induction air and should be held for 7 seconds. Turning the Key Switch further to Position "🌀" (Start) provides power to the starter motor which cranks the engine. The starter motor will be disengaged when the Key Switch is released so it must be held in this position until the engine starts and then immediately released and allowed to return to Position "I" (On).

To prevent overheating of the starter motor the engine should not be cranked for more than 5 to 7 seconds. An interval of 10 seconds should be allowed between start attempts. If the engine has not started after 4 attempts, refer to the trouble shooting guide or Engine Manual to determine the cause of failure to start.

Turning the Key Switch past Position "I" (On) initiates the Fault Protection Timer (FPT) relay. This timer is set at 15 seconds but is adjustable on the P.C.B. Until the FPT times out the high engine coolant temperature and low oil pressure protective circuits are inhibited. This will keep the low oil pressure of a starting engine from causing the protection circuits to initiate a shutdown during start.

Should the oil pressure not have reached the proper specified operating point by the time FPT times out or, when running, should the pressure drop below this level, the protective circuitry will initiate a shutdown. The "LOW OIL PRESSURE" fault lamp will illuminate. Start up will be inhibited and no attempt should be made to start the set until the cause of the fault has been traced and remedied. High engine coolant temperature (and/or low coolant level on some larger models) will also shut down the generator set in the same way and will illuminate the "HIGH ENGINE TEMP" fault lamp.

WARNING:

! **If at any time the generator set stops because of a fault, the fault should be rectified before trying to restart the generator.**

These protective circuits will prevent start of the generator set until they are reset. Turning the Key Switch to Position "O" (Off) resets the protective circuits of the control system.

Once the generator set is running properly, the electrical load is applied to the set by switching the alternator output circuit breaker to "ON" (handle in the up position).

When shutting down the generator set, the load should be turned off by switching the alternator output circuit breaker to "OFF" (handle down). The engine should be allowed to cool prior to stopping it. After a few minutes the Key Switch is turned to Position "O" (Off) which shuts the generator set down.

In case of emergency where immediate shutdown is necessary, the Emergency Stop button should be pressed immediately without first disconnecting the load.

9.2.2 Protective Circuits (1001 Series): Engine coolant temperature is monitored by the high temperature switch located on the engine. This is a normally open switch designed to close at 95°C (203°F). On closing, relay R1

energizes and self latches, illuminating the red colored fault lamp labeled "HIGH ENGINE TEMPERATURE". The second set of contacts on R1 (R1/2) opens to break the circuit that was energizing the control relay (CR). This closes the fuel solenoid valve, shutting down the engine. The fault lamp will remain illuminated and the engine locked out until the fault has been acknowledged and reset by turning the Key Switch to Position "O" (Off). On some larger models a low coolant level sensor will also cause the generator set to shut down and will also illuminate the "HIGH ENGINE TEMPERATURE" fault lamp even though the temperature may be in the normal range.

Engine lubricating oil pressure is also monitored to check for an excessively low pressure condition. This is monitored by an engine mounted, normally closed, switch that opens under normal running conditions. Should the oil pressure fall to or below about 22 p.s.i. (1.6 bar) the switch will close. This in turn energizes relay R5 which self latches, illuminating the "LOW OIL PRESSURE" fault lamp. The second set of contacts (R5/2) opens de-energizing the CR relay. This causes the fuel solenoid valve to close and the engine to shutdown. Reset is effected by turning the Key Switch to Position "O" (Off).

9.3 Functional Description 2001, 4001 and 4001E Series Control Systems

The 2001, 4001 and 4001E Series Control Systems provide for automatic starting and stopping of the generator set from a remote signal as well as manual starting and stopping. This makes it appropriate for standby generating systems. Protection is provided by the control system against high engine coolant temperature, low oil pressure, fail to start and overspeed. On the 4001 and 4001E Series Control Systems alarm protection is also provided for Low Battery Voltage. On 4001E Series Control Systems there are additional alarms for Approaching Low Oil Pressure, Approaching High Engine Temperature, Battery Charger Failure and Not in Auto Mode.

These control systems are of the relay timer type based on a double sided Printed Circuit Board (P.C.B.). The P.C.B. is off board fuse protected and controls the starting, stopping and fault protection of the engine. Figures 9.3, 9.4 and 9.5 show the layout of the 2001 Series P.C.B., the 4001 Series P.C.B. and the 4001E Series Expansion P.C.B. respectively.

Since these control systems are designed for automatic starting, they are fitted with connections for remote control. Included are terminals for Remote Emergency Stop and an interface to an Intelligent Load Transfer Panel. Additionally, the 4001 and 4001E Series Control Systems are fitted with an interface to Remote Annunciators which are described in Section 9.4.8.

9.3.1 Function (2001, 4001 and 4001E Series): Section 5 of this manual provides detailed guidance and checklists for the operation of the generator set. This section provides a more detailed description of the functions of the control system during operation.

When the Control Switch is turned to "RUN" or a remote start signal is received with the Control Switch in the "AUTO" position, the control system will initiate its automatic start sequence. The fuel control solenoid is turned on providing fuel to the engine. The starter motor is then energized via the auxiliary start solenoid (ASS) to crank the engine. If the engine does not start after a preset duration (CYTON) then a delay of a preset duration (CYTOFF) will elapse before cranking again.

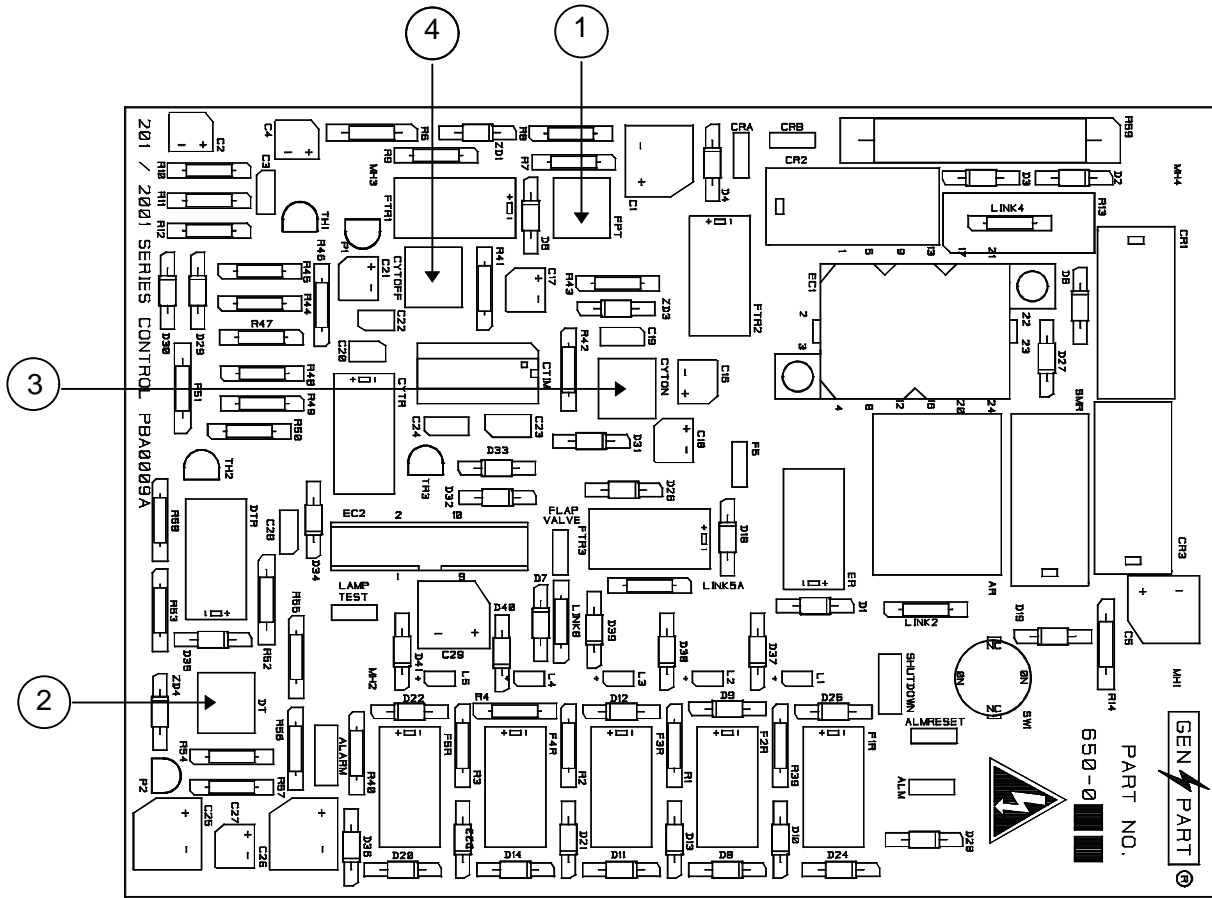

<u>Item</u>	<u>Description</u>		<u>Item</u>	<u>Description</u>
1.	FPT: Fault Protection Timer Adjust Range: 1-70 seconds Set: 15 ± 1 second	3.	CYTON: Crank On Period Range: 0.25-20 seconds Set: 5 ± 1 second	
2.	DT: Duration Timer (sets duration of cranking sequence) Range: 1-90 seconds Set: 27.5 ± 2.5 seconds	4.	CYTOFF: Crank Off Period Range: 0.25-20 seconds Set: 5 ± 1 second	

Figure 9.3: Layout of the 2001 Series P.C.B.

<u>Item</u>	<u>Description</u>	<u>Item</u>	<u>Description</u>
1.	TEMP: Approaching High Engine Temperature Set Point Set: 90°C ± 1°C	7.	IDLT: Input Delay Timer Set Range: 0.25-30 seconds Set: 1 ± 0.5 seconds
2.	SW1: Shutdown/Alarm Selector for Fault L12	8.	BCV: Battery Charger Failure Detection Set Point Set: 11.75 volts for 12 volt systems 22.25 volts for 24 volt systems
3.	SW2: Shutdown/Alarm Selector for Fault L13	9.	LINK 6: Battery Charger Failure Operating Mode
4.	SW3: Shutdown/Alarm Selector for Fault L14		
5.	SW4: Shutdown/Alarm Selector for Fault L15		
6.	BCT: Battery Charger Timer Set Range: 3-330 seconds Set: 180 ± 15 seconds		

Figure 9.5: Layout of the 4001E Series Expansion P.C.B.

If the engine fails to fire after 3 start attempts then the "FAIL TO START" fault lamp will illuminate. The number of starts is dependent on the setting of CYTON, CYTOFF and the Duration Timer DT. With CYTON and CYTOFF set at 5 seconds and DT set at 27.5 seconds, this gives 3 crank attempts before FAIL TO START - 5 seconds on, 5 seconds off, 5 seconds on, 5 seconds off, 5 seconds on, 2½ seconds off, "FAIL TO START". Refer to the trouble shooting guide or Engine Manual to determine the cause of failure to start. Start will be inhibited until the protection circuits of the control system are reset by turning the Control Switch to "STOP" for the 2001 panel or by pressing the P.C.B RESET button for the 4001 and 4001E panels. All time periods are approximate.

When the engine fires and is above cranking speed the starter motor is automatically disengaged. This condition is detected from the W/L terminal of the engine driven battery charging alternator. In addition, when the generator is providing voltage a back up signal is sent to cancel the start sequence. The voltage of the alternator is detected via relay AR.

Note:

- As soon as the generator starts, the power supply to the engine auxiliaries is disconnected via contactor HC, when fitted. Whenever the generator stops contactor HC re-energizes and reconnects the supply to the auxiliaries.

The beginning of the start sequence initiates the Fault Protection Timer (FPT) relay. Until the FPT times out (factory set at 15 seconds) the low oil pressure and high engine coolant temperature protective circuits are inhibited. This will keep the low oil pressure of a starting engine from causing the protection circuits to initiate a shutdown.

Should the oil pressure not have reached the proper specified operating point by the time FPT times out or, when running, should the pressure drop below this level, the protective circuitry will initiate a shutdown. The "LOW OIL PRESSURE" fault lamp will illuminate. Startup will be inhibited and no attempt should be made to start the set until the cause of the fault has been traced and remedied. High engine coolant temperature (and/or low coolant level on some larger models) will shut down the generator set and will illuminate the "HIGH ENGINE TEMPERATURE" fault lamp. An overspeed condition will, in the same way, shut down the set and illuminate the "OVERSPEED" fault lamp.

WARNING:

! If at any time the generator set stops because of a fault, the fault should be rectified before trying to restart the generator.

These protective circuits will prevent start of the generator set until they are reset. Turning the Control Switch to "STOP" for the 2001 panel or by pressing the P.C.B RESET button for the 4001 and 4001E panels resets the system.

Manually the generator set can be stopped at any time by pressing the Emergency Stop Pushbutton or by turning the Control Switch to "STOP". The set will also automatically shutdown when the remote start signal is removed. On 4001 and 4001E Control System the Run On Timer (ROT) will allow a cool down period at low power prior to shutdown.

9.3.2 Protective Circuits (2001, 4001 and 4001E Series):

Engine coolant temperature is monitored by the high temperature switch located on the engine. This is normally an open switch designed to close at 95°C (203°F). On closing, a relay energizes and self latches, which illuminates the "HIGH ENGINE TEMPERATURE" fault lamp. It also breaks the circuit energizing the control relay

(CR). This closes the fuel solenoid valve, shutting down the engine. The fault lamp will remain illuminated and the engine locked out until the fault has been acknowledged and reset by turning the Control Switch to "STOP" for the 2001 panel or by pressing the P.C.B RESET button on the 4001 and 4001E panels. On some larger models a low coolant level sensor will also cause the generator set to shut down and will also illuminate the "HIGH ENGINE TEMPERATURE" fault lamp even though the temperature may be in the normal range.

Engine lubricating oil pressure is also monitored to check for an excessively low pressure condition. This is monitored by an engine mounted, normally closed, switch that opens under normal running conditions. Should the oil pressure fall to or below about 22 p.s.i. (1.6 bar) the switch will close. This in turn energizes a relay which self latches, and illuminates the "LOW OIL PRESSURE" fault lamp. Again the relay CR is de-energized which causes the fuel solenoid valve to close and the engine to shutdown. Reset is effected by turning the Control Switch to "STOP" for the 2001 panel or by pressing the RESET button on the P.C.B for the 4001 and 4001E panels.

The OVERSPEED fault is monitored by the E.I.M via the speed signal from the magnetic pick-up. If the engine speed rises above a certain pre-settable value, the module sends a zero volt signal to the generator set control panel to activate the Overspeed Fault circuitry. Upon this signal a relay energizes and self latches, which illuminates the "OVERSPEED" fault lamp. Again the relay CR is de-energized which causes the fuel solenoid valve to close and the engine to shutdown. Reset is effected by turning the Control Switch to "STOP" for the 2001 panel or by pressing the RESET button on the P.C.B for the 4001 and 4001E panels.

The Low Battery Voltage alarm which is fitted as standard on the 4001 and 4001E Series Control Systems detects the battery voltage and compares it to an adjustable reference (LBV) which is factory set at 10.75 volts for 12 volt systems and 22.75 volts for 24 volt systems. This alarm has a built in time delay to prevent spurious tripping such as when the engine is cranking.

Four additional Alarm circuits are provided on the 4001E Series Control System. The Approaching Low Oil Pressure and Approaching High Engine Temperature alarms work off the sensors fitted for the gauges. The temperature alarm is factory set to go off at 90°C ± 1°C. The Not in Auto Mode Alarm senses the position of the Control Switch. The Battery Charger Failure Alarm detects low voltage from the charger. This level (BCV) is factory set at 11.75 volts for 12 volt systems and 22.25 volts for 24 volt systems. This alarm can be operated in one of 3 modes depending on the position of Link 6 on the 4001E Expansion P.C.B. (see diagrams below):

Mode 1: Link in Position 1

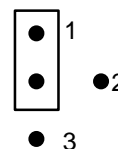

For generator sets with trickle charger and engine driven charging alternators. In this position the charger failure circuit only monitors when the engine is not running.

Mode 2: Link in Position 2

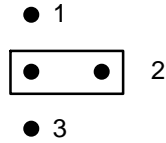

For generator sets fitted with AC powered chargers only (no engine driven charging alternator.)

Mode 3 Link in Position 3

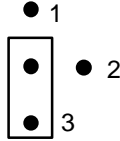

For generator sets with no battery charger fitted. In this position the charger failure circuit is **disabled**.

The 2001 Series Control System has one additional channel beyond the standard that can be either a Shutdown circuit or an Alarm circuit depending on how it is programmed at the factory.

The 4001 Series Control System has one additional Shutdown circuit and one additional Alarm circuit beyond the standard. The use of these circuits is programmed at the factory.

The 4001E Series Control System has two additional Shutdown circuits, one additional Alarm circuit and four additional circuits that can be either Shutdown or Alarm circuit. Each of these is programmed at the factory.

The additional possible Shutdown circuits (not all available on all sets) include shutdown on:

- High Lube Oil Temperature
- Low Coolant Level
- Low Fuel Level
- Underspeed
- Overvoltage
- Undervoltage
- Earth Fault
- Earth Leakage
- Combined Over/Under Voltage

The additional possible Alarm circuits (not all available on all sets) include alarms for:

- Low Fuel Level
- Low Coolant Temperature

For the 2001 Series Control System, the Fault Indicating Lamps are grouped on the control panel as follows:-

- L1 Fail To Start Shutdown
- L2 High Engine Temperature Shutdown
- L3 Low Oil Pressure Shutdown
- L4 Overspeed Shutdown
- L5 Additional Shutdown or Alarm (programmed at factory)

For the 4001 Series Control System, the Fault Indicating Lamps are grouped on the control panel as follows:-

- L1 Fail To Start Shutdown
- L2 High Engine Temperature Shutdown
- L3 Low Oil Pressure Shutdown
- L4 Overspeed Shutdown
- L5 Additional Shutdown
- L6 Low Battery Alarm
- L7 Additional Alarm

For the 4001E Series Control Systems nine additional Fault Indicating Lamps are included on the separate 4001E expansion P.C.B. which are grouped on the control panel as follows:-

- L8 Not In Auto Alarm
- L9 Approaching High Engine Temperature Alarm
- L10 Approaching Low Oil Pressure Alarm
- L11 Battery Charger Failure Alarm
- L12 Programmable Channel 1
- L13 Programmable Channel 2

- L14 Programmable Channel 3
- L15 Programmable Channel 4
- L16 Additional Shutdown

Indicators L12-L14 are programmed for shutdown or alarm functions using the Dil switches on the P.C.B.

The DIL switches are assigned as follows:

Fault Channel	Dil Switch
L12	SW1
L13	SW2
L14	SW3
L15	SW4

The setting of these programmable Fault Indicator Lamps can be checked on the P.C.B. With both poles in "SD" position, the fault channel is configured as a shutdown. With both poles in "ALM" position, the fault channel is configured as an alarm.

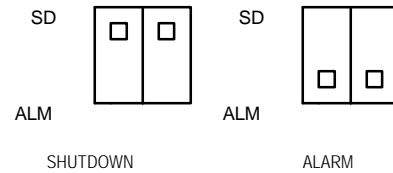

9.4 Control System Options and Upgrades

A large variety of options may be fitted to customize the control system to a specific installation. The following sections cover the use and operation of some of these options.

9.4.1 Battery Trickle Chargers: These chargers are designed to ensure that the starter batteries maintain their charge even if the generator set is not operated for long periods.

The chargers are generally available with a 5 Amp nominal rating and are usually mounted within the control panel. A 10 Amp nominal rating battery charger may be fitted in some circumstances but would be located in a separate box placed adjacent to the control panel. These chargers require a continuous electrical power supply of either 220/240 volts AC or 120 volts AC depending on the charger.

Control switches for the chargers are not normally fitted to prevent inadvertent switching off of the charger. The control system will automatically disconnect the charger on startup of the generator set. While the engine is running the batteries are charged by the engine driven battery charging alternator.

As additional options, an "ON"/"OFF" switch and a battery charger boost control may be fitted. The boost control overrides the automatic control mechanism of the charger that would normally reduce charging level as the battery becomes charged. This can allow faster charging of the battery, however care must be taken to only use the boost control for a short time to avoid overcharging the battery and/or boiling the battery dry.

As an option, a battery charger ammeter may be fitted to the control panel in order for the operator to monitor the functioning of the battery charger.

9.4.2 Heaters: In addition to conventional space heaters that are useful in keeping the generator set warm and dry in cold or humid environments, four types of heater may be fitted on the generator set.

For water cooled engines, immersion type heaters (engine heaters) may be fitted in the engine coolant system to ensure that the engine is easy to start and able to take load more quickly. These heaters are provided with an integral non-adjustable thermostat set at approximately 40°C (104°F).

Alternator anti-condensation heaters (alternator heaters) may be fitted to the alternator stator winding to keep them dry in humid conditions. These are in the form of "heat-tracing" tape and operate at relatively low temperatures so they do not require a thermostat.

Lube oil sump heaters (sump heaters) may be fitted to the sump when the generator is to be sited in a low ambient temperature environment. The heater maintains the engine lubricating oil at a temperature which facilitates rapid starting and load acceptance.

AC Powered Battery heater (Battery Heater) may be fitted to the battery when the generator is sited in a low ambient temperature environment. The heater maintains the battery at an optimum operating temperature allowing full rated current to be drawn (providing that the battery is in a fully charged condition). The heater includes a thermostatic controller to regulate the output temperature to within safe limits.

All of these heater types require a continuous AC power source. The heaters are automatically disconnected on engine start-up.

9.4.3 Electric Fuel Transfer Pumps: Fuel transfer pumps are required when fuel must be transferred from a bulk storage tank to the generator set day tank. An AC pump requiring a 220/240 volt AC power supply may be fitted. These pumps are generally mounted on the baseframe and float switches are fitted in the day tank. Control relays, switches, lamps and overloads are fitted in the control panel.

The controls consist of two illuminated pushbuttons on the control panel door. The red button is a combined trip lamp and stop button. The green button is a run lamp and manual start pushbutton.

To operate the pump manually, ensure the red pushbutton is in the "ON" position (pulled out). Press and hold the green pushbutton to manually run the pump. The pump will only run in the manual mode while the green button is held in.

To operate the pump in automatic mode, just ensure that the red pushbutton is in the "ON" position (pulled out). A DC relay inside the panel (PR) is energized by a low level float switch in the day tank. This will start the pump running and will illuminate the green run lamp. A high level float switch in the day tank de-energizes relay PR when the tank is full. This stops the pump and turns off the green run lamp.

An electrical overload is sensed if the pump draws significantly more current than normal. When this occurs the red lamp will illuminate.

Care must be taken to ensure that the pump is primed with fuel prior to operation to lubricate the seals. Also, the pump should never be run when the bulk tanks are empty or when valves on the fuel fill lines are closed.

9.4.4 Meters/Gauges: When more information is required than that which is provided by the standard panels, the following meters or gauges may be fitted to the control panel:

3 *Ammeters* mounted on the panel instead of one ammeter and a selector switch. This allows a continuous indication of the current flowing in each phase.

Kilowatt (kW) Meter to provide accurate readings of the load being supplied by the generator set. The meter is mounted on the control panel and the transducer is mounted inside the panel.

Combined Tachometer and Frequency Meter to replace the standard frequency meter. This meter allows both engine speed in revolutions per minute (RPM) and output frequency to be indicated on the front panel.

Lube Oil Temperature Gauge to monitor the lubricating oil temperature when the engine is operating. This is an

electrical device powered by the generator set battery. The normal operating temperature should be approximately 90°-110°C (195°-230°F).

Ammeter for Battery Trickle Charger to monitor the current flow to the battery. It is used to observe the charging current being supplied by the battery trickle charger. When the batteries are fully charged this current will be small (less than 5 Amps) but with a partially discharged battery this current may be as high as 40 Amps.

9.4.5 Speed/Voltage Control: Three controls may be fitted to adjust the speed or voltage of the generator set.

The *speed adjust potentiometer* can only be used when the engine is controlled by an electronic governor. Clockwise adjustment increases the speed of the engine and anti-clockwise adjustment decreases it. The potentiometer is fitted with a dial mechanism which allows the potentiometer to be locked at the desired setting.

A *raise/lower switch* may be fitted on the control panel to control the speed of engines with mechanical or hydraulic governors. The governor must also be fitted with a motor operator. A "spring return to off" switch is then used to raise or lower the speed.

The *voltage adjust potentiometer* allows minor adjustments of voltage to be made from the control panel. About 3% adjustment is possible

9.4.6 Alarm Signaling: Three options may be fitted to the control panel to supplement the standard alarm indications of the alarm lamps:

A *panel mounted alarm siren* is DC operated and will sound when an alarm condition is indicated. An Alarm Mute pushbutton is fitted on the panel to silence the siren.

An *audible alarm siren supplied loose* is also DC powered and will sound when an alarm condition is indicated. It can be fitted at a convenient location. An Alarm Mute pushbutton is fitted on the panel to silence the siren.

A *set of volt free contacts for common alarm* change over in the event of an alarm condition. These are for connection to an existing alarm system. These contacts remain in the "alarm" state until the control system is reset.

9.4.7 Automatic Preheat Control: The thermostart induction air preheating operates automatically prior to and during engine cranking. The automatic cranking sequence will be delayed by the preheating period.

9.4.8 Remote Annunciator Panels: 8 or 16 channel remote annunciators may be fitted and connected to 4001 and 4001E Series Control Systems. These provide repeat indicators for the shutdown and alarm fault lamps on the control panel. They also include an audible alarm and alarm mute button. The connection is via a plug type terminal bar for easy installation.

Each channel is equipped with a LED that can display red, green or amber depending on the selection of the DIL switches. Each channel can also be selected to sound the audible alarm via a DIL switch.

Two further options may be fitted with the remote annunciators: A Normal/Run switch allows manual starting of the set from the remote location and an Emergency Stop Pushbutton allows manual stopping.

9.5 Control System Fault Finding/Trouble Shooting Guide

FAULT	SYMPTOM	REMEDY
Engine Fails to Start (1001 Series Only)	Engine Does Not Crank when Key Switch Turned to Position "🔑" (Start)	<ol style="list-style-type: none"> 1. Check all Emergency Stop Pushbuttons are released (including any remote buttons). 2. Check operation of Key Switch. 3. Check no fault lamps illuminated. Reset, if required, after remedying indicated fault. 4. Check battery voltage on control panel. If voltage is not registering check fuses F4 and F5. If voltage is registering but is low then recharge the batteries with separate battery charger and reconnect to the set. (Ensure Key Switch is in Position 'O' (Off) when disconnecting and reconnecting the battery leads.) 5. Check supply to slave solenoid on starter motor - connect a DC voltmeter between this connection and the battery negative terminal. Try starting the engine using the Key Switch. If the meter registers a voltage then the starter motor or solenoid is faulty and must be replaced. If no voltage registers, check wiring from panel for loose connections or broken/shorted wires.
Engine Fails to Start (2001, 4001, or 4001E Series Only)	Engine Does Not Crank when Start Signal Given, Either Manually Via Control Switch or Automatic-ally Via a Remote Signal	<ol style="list-style-type: none"> 1. Check all Emergency Stop Pushbuttons are released (including any remote buttons). If no remote stop is used, ensure "Remote Stop" terminals are linked. 2. Check that Control Switch is not off. 3. Check no fault lamps illuminated. Reset, if required, after remedying indicated fault. 4. Check battery voltage on control panel. If voltage is not registering check fuse F5. If voltage is registering but is low then recharge the batteries with separate battery charger and reconnect to the set. (Ensure the Control Switch is off when disconnecting and reconnecting the battery leads.) 5. Check supply to slave solenoid on starter motor - connect a DC voltmeter between this connection and the battery negative terminal. Try starting the engine manually by turning the Control Switch to RUN. If the meter registers a voltage then the starter motor or solenoid is faulty and must be replaced. If no voltage registers, check wiring from panel for loose connections or broken/shorted wires. 6. If wiring is not damaged then replace the P.C.B.
Engine Fails To Start (All control systems)	<p>Engine Cranks But Does Not Fire or</p> <p>Engine Starts But Stops After 20 Seconds ("FAIL TO START" Fault Lamp Illuminates on 2001, 4001 or 4001E Panels.)</p>	<ol style="list-style-type: none"> 1. Check fuel level. 2. Check that Canopy External Emergency Stop Pushbuttons, if fitted, are not depressed (1001 Series). 3. Check wiring to the fuel control solenoid "FCS" and the voltage at the FCS. 4. Check fuses F1, F2, F3 on alternator side plate. 5. Check fuel lines and fuel filter for obstructions. 6. If white smoke comes from the exhaust then fuel is entering the engine but the engine is not firing. Refer to the Engine Manual for further checks. 7. If ambient temperature is low ensure thermostart aid is used, if fitted. 8. Check voltage output of P.C.B. to FCS. If signal not present, Replace the P.C.B. 9. Once the fault has been rectified, clear the fault lamp by turning the Control Switch to STOP for the 2001 panel or by pressing the P.C.B RESET button on the 4001 and 4001E panels.
Engine Stops Due to High Engine Temp. (or on some larger models due to Low Coolant Level) (All control systems)	"HIGH ENGINE TEMP" Fault Lamp Illuminates	<ol style="list-style-type: none"> 1. Check engine was not overloaded. 2. Check radiator obstructions. 3. Check fan belt tension. 4. Check ambient temperature is within the design limits of the generator set. 5. After engine has cooled, check coolant level. Do not add large amounts of cold water to a hot engine as serious damage could result. 6. Refer to Engine Manual. 7. Once fault has been rectified, clear the fault lamp by turning the Key Switch to position "O" (Off) for the 1001 panel , Turning the Control Switch to "STOP" for the 2001 panel or by Pressing the P.C.B RESET button on the 4001 and 4001E panels , as appropriate. 8. Cool the engine by starting and running it off-load for 10 minutes with the circuit breaker off (handle down).

FAULT	SYMPTOM	REMEDY
Engine Stops Due to Low Oil Pressure (All control systems)	"LOW OIL PRESSURE" Fault Lamp Illuminates	<ol style="list-style-type: none"> 1. Check oil level. 2. Refer to Engine Manual. 3. Check oil pressure switch with test gauge. Replace if faulty. 4. Once fault has been rectified, clear the fault lamp by turning the Key Switch to position "O" (Off) for the 1001 panel , Turning the Control Switch to "STOP" for the 2001 panel or by Pressing the P.C.B RESET button on the 4001 and 4001E panels as appropriate.
Engine Stops Due to Overspeed (2001, 4001 or 4001E Series Only)	"OVERSPEED" Fault Lamp Illuminates	<p>Note: The "OVERSPEED" fault lamp will also illuminate after the Emergency Stop Pushbutton has been depressed even though there has been no overspeed condition. The Emergency Stop Pushbutton and any remote stop buttons must be released before the fault can be cleared.</p> <ol style="list-style-type: none"> 1. Check if governor speed setting lever has moved. Re-adjust if required. 2. If electronic governor is fitted check linkage for free movement. Adjust if required. 3. Refer to Engine Manual. 4. Replace the P.C.B. 5. Once fault has been rectified, clear the fault lamp by turning the Control Switch to "STOP" for the 2001 panel or by pressing the P.C.B RESET button on the 4001 and 4001E panels.
Engine Stops Due to High Lube Oil Temp (Optional Shutdown - 2001, 4001 or 4001E Series Only)	"HIGH LUBE OIL TEMP" Fault Lamp Illuminates	<ol style="list-style-type: none"> 1. See trouble shooting guide on "Engine Stops Due To High Engine Temp" to see if cooling system is operating efficiently. 2. After radiator has cooled, check coolant level. 3. Check oil level. 4. Ensure proper maintenance procedures have been carried out. 5. Refer to Engine Manual. 6. Once fault has been rectified, clear the fault lamp by turning the Control Switch to "STOP" for the 2001 panel or by pressing the P.C.B RESET button on the 4001 and 4001E panels.
Engine Stops Due to Low Coolant Level (Optional Shutdown - 2001, 4001 or 4001E Series Only)	"LOW COOLANT LEVEL" Fault Lamp Illuminates	<ol style="list-style-type: none"> 1. Allow engine to cool. 2. Check coolant level. Fill as required with correct coolant mixture. Do not add large amounts of cold water to a hot engine as serious damage could result. 3. Check radiator, engine and pipework for leaks. Repair as necessary. 4. Once fault has been rectified, clear the fault lamp by turning the Control Switch to "STOP" for the 2001 panel or by pressing the P.C.B RESET button on the 4001 and 4001E panels.
Engine Stops Due to Low Fuel Level (Optional Shutdown - 2001, 4001 or 4001E Series Only)	"LOW FUEL LEVEL" Fault Lamp Illuminates	<ol style="list-style-type: none"> 1. Check fuel level in day tank. Fill as necessary. 2. Check operation of the fuel transfer system , if fitted, as described in Section 9.4.3. 3. Once fault has been rectified, clear the fault lamp by turning the Control Switch to "STOP" for the 2001 panel or by pressing the P.C.B RESET button on the 4001 and 4001E panels.
Engine Stops Due to Underspeed (Optional Shutdown - 2001, 4001 or 4001E Series Only)	"UNDERSPEED" Fault Lamp Illuminates	<ol style="list-style-type: none"> 1. Ensure engine has not been overloaded. 2. Ensure there is an adequate supply of fuel to the engine. 3. Check if governor speed setting lever has moved. Re-adjust if required. 4. If electronic governor is fitted check linkage for free movement. Adjust if required. 5. Clear the fault by turning the Control Switch to "STOP" and restart the engine. 6. Ensure alternator is running at the correct voltage by checking on the panel meters. 7. With engine running set correct speed on the engine governor control. 8. Refer to the Engine Manual.

FAULT	SYMPTOM	REMEDY
Engine Stops Due to Overvoltage (Optional Shutdown - 2001, 4001 or 4001E Series Only)	"OVERVOLTAGE" Fault Lamp Illuminates	<ol style="list-style-type: none"> 1. Disconnect the alternator from the load by turning off the circuit breaker (handle down), reset the fault by turning the Control Switch to "STOP" and restart engine. 2. Check voltage on panel meters. If voltage is normal, ensure that the load is non-capacitive (power factor correction equipment may inadvertently lead to a capacitive load). 3. If voltage remains high and can not be adjusted to the normal level using the voltage adjust potentiometer, if fitted, then refer to the Alternator Manual.
Engine Stops Due to Under-voltage (Optional Shutdown - 2001, 4001 or 4001E Series Only)	"UNDERVOLTAGE" Fault Lamp Illuminates	<ol style="list-style-type: none"> 1. Disconnect the alternator from the load by turning off the circuit breaker (handle down), reset the fault by turning the Control Switch to "STOP" and restart engine. 2. Check voltage on panel meters. If voltage is normal check the load characteristics (i.e. ensure not overloaded). 3. If voltage remains low and can not be adjusted to the normal level using the voltage adjust potentiometer, if fitted, then check the voltage at the alternator terminals with an independent meter. If voltage is correct check wiring. 4 Check AVR. 5. Refer to Alternator Manual.
Engine Stops Due to Overvoltage /Under-voltage (Optional Shutdown - 2001, 4001 or 4001E Series Only)	"OVERVOLTAGE/UNDER-VOLTAGE" Fault Lamp Illuminates	<ol style="list-style-type: none"> 1. Disconnect the alternator from the load by turning off the circuit breaker (handle down), reset the fault by turning the Control Switch to "STOP" and restart engine. 2. Check voltage on panel meters. If voltage is normal check the load characteristics (i.e. not capacitive and not overloaded). 3. If voltage remains high or low and can not be adjusted to the normal level using the voltage adjust potentiometer, if fitted, then check the voltage at the alternator terminals with an independent meter. If voltage is correct check wiring. 4 Check AVR. 5. Refer to Alternator Manual.
Engine Stops Due to Earth Fault (Optional Shutdown - 2001, 4001 or 4001E Series Only)	"EARTH FAULT" Fault Lamp Illuminates	<ol style="list-style-type: none"> 1. Check all cable and wiring for bad connections or shorts to earth. 2. Check alternator windings - refer to Alternator Manual. 3. Once the fault has been rectified, clear the fault lamp by turning the Control Switch to "STOP" for the 2001 panel or by pressing the P.C.B RESET button on the 4001 and 4001E panels.
Engine Stops Due to Earth Leakage (Optional Shutdown - 2001, 4001 or 4001E Series Only)	"EARTH LEAKAGE" Fault Lamp Illuminates	<ol style="list-style-type: none"> 1. Check outgoing cable and wiring for faults. 2. Do not restart the generator set until fault has been found. 3. Once the fault has been rectified, clear the fault lamp by turning the Control Switch to "STOP" for the 2001 panel or by pressing the P.C.B RESET button on the 4001 and 4001E panels.
Alarm for Low Battery Voltage (4001 or 4001E Series Only)	"LOW BATTERY VOLTAGE" Alarm Lamp Illuminates	<ol style="list-style-type: none"> 1. Check battery voltage at least 12 volts for a 12 volt system or at least 24 volts for a 24 volt system. 2. If voltage is low and generator set is not running then recharge the battery by connecting a separate battery charger to the disconnected battery or run the engine. 3. If voltage is low and generator set is running then the battery charging alternator is not charging. Stop the set and check the fan belt tension. 4. If fan belt tension is correct then check battery charging alternator - refer to Engine Manual. 5. If battery does not hold a charge then replace battery. 6. Once the cause of the alarm has been rectified, clear the alarm lamp by pressing the "LAMP TEST" button.
Alarm for Not in Automatic Mode (4001E Series Only)	"NOT IN AUTO MODE" Alarm Lamp Illuminates	<ol style="list-style-type: none"> 1. Check Control Switch is in "AUTO". 2. Check Emergency Stop Pushbuttons are not pressed. 3. Check Circuit Breaker is on (handle up). 4. Once the cause of the alarm has been rectified, clear the alarm lamp by pressing the "LAMP TEST" button.

FAULT	SYMPTOM	REMEDY
Alarm for Approaching High Engine Temp. (4001E Series Only)	"APPROACHING HIGH ENGINE TEMP" Alarm Lamp Illuminates	<ol style="list-style-type: none"> 1. Check engine is not overloaded. 2. Check radiator and ventilation for obstructions. 3. Check ambient temperature is within the design limits of the generator set. 4. If the above are okay, reduce load and stop the set as soon as possible. Check the fan belt tension. 5. Refer to Engine Manual. 6. Once the cause of the alarm has been rectified, clear the alarm lamp by pressing the "LAMP TEST" button.
Alarm for Approaching Low Oil Pressure (4001E Series Only)	"APPROACHING LOW OIL PRESSURE" Alarm Lamp Illuminates	<ol style="list-style-type: none"> 1. Check oil level with engine stopped as soon as possible. 2. Refer to Engine Manual. 3. Once the cause of the alarm has been rectified, clear the alarm lamp by pressing the "LAMP TEST" button.
Alarm for Battery Charger Failure (4001E Series Only)	"BATTERY CHARGER FAILURE" Alarm Lamp Illuminates	<ol style="list-style-type: none"> 1. Check trickle charger is switched on and producing power. 2. Carry out checks as per low battery voltage alarm. 3. Once the cause of the alarm has been rectified, clear the alarm lamp by pressing the "LAMP TEST" button.
Alarm for Low Fuel Level (Optional Alarm - 2001, 4001 or 4001E Series Only)	"LOW FUEL LEVEL" Alarm Lamp Illuminates	<ol style="list-style-type: none"> 1. Check fuel level in day tank. Fill as necessary. 2. Check operation of the fuel transfer system, if fitted, as described in Section 9.4.3. 3. Once the cause of the alarm has been rectified, clear the alarm lamp by pressing the "LAMP TEST" button for the 4001 and 4001E panels or by turning the control switch to "STOP" for the 2001 panel.
Alarm for Low Coolant Temp. (Optional Alarm - 2001, 4001 or 4001E Series Only)	"LOW COOLANT TEMP" Alarm Lamp Illuminates	<ol style="list-style-type: none"> 1. Check that the immersion heaters are switched on and are operating. 2. Once the cause of the alarm has been rectified, clear the alarm lamp by pressing the "LAMP TEST" button for the 4001 and 4001E panels or by turning the control switch to "STOP" for the 2001 panel.
No Voltage Produced When Generator set is Running (All control systems)	No Voltage On AC Voltmeter	<ol style="list-style-type: none"> 1. Check voltmeter selector switch is not in the "OFF" position. 2. Check fuses F1, F2, and F3, usually located on the alternator terminal box. 3. Check voltage at alternator terminals with an independent meter. If voltage is correct check wiring between alternator and panel. Check voltmeter. Replace if necessary. 4. Check AVR and rotating diodes. Refer to Alternator Manual for details. 5. Check engine speed is correct.
Generator set Does Not Go On Load (All control systems)	Generator set is Running but the Load is Not Being Powered	<ol style="list-style-type: none"> 1. Check circuit breaker is "ON" (handle up). 2. Check generator set is producing AC voltage. If not, see fault above.
Generator set Does Not Stop Manually (All control systems)	Generator set Continues Running After Being Switched Off	<ol style="list-style-type: none"> 1. Check Key Switch or Control Switch position, as appropriate. 2. Check fuel control solenoid (FCS). Replace if necessary.
Generator set Does Not Stop When In Auto Mode (2001, 4001 or 4001E Series Only)	Generator set Does Not Stop After Remote Start Signal is Removed	<p>Note: On 4001 and 4001E Series Control Systems the generator set does not stop immediately on removal of the remote start signal. Removal of this signal first initiates the cool down period.</p> <ol style="list-style-type: none"> 1. Wait 5 minutes to ensure cool down period has elapsed (4001 and 4001E Series Control Systems Only). 2. Check that generator set stops when the Emergency Stop Pushbutton is depressed or the Control Switch is turned off. 3. If the set does not stop as in step 2 above then check the fuel control solenoid (FCS). Replace if necessary.

9.6 Load Transfer Panel

When the generator set is installed to automatically provide standby power in the event of mains failure, a load transfer panel is required. This transfer panel is designed to sense when the mains have failed, signal the generator set to start, switch the load from the failed mains to the generator set and then switch it back after the mains are re-established. See Figure 9.6.

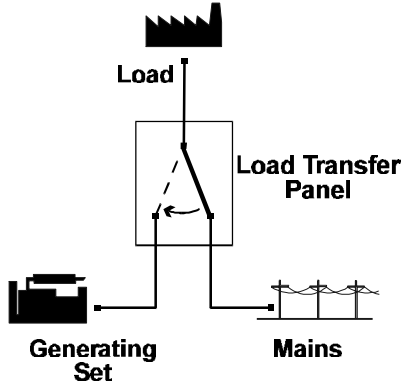

Figure 9.6: Function of a Load Transfer Panel

There is one standard range of Load Transfer Panel: The TI Series Intelligent Transfer Panel.

9.6.1 TI Intelligent Load Transfer Panel: The TI Intelligent Load Transfer Panel is designed to work with the Autostart Control Systems (2001, 4001, and 4001E Series) to form an automatic mains failure system. Only a two wire control interconnection is necessary between the generator set control panel and the TI panel making the installation very simple.

The control system consists of two Printed Circuit Boards (P.C.B.'s), control switches, a status panel and the contactors. The TI P.C.B. (see Figure 9.8) controls all the detection and monitoring circuits, the mode control switch and fuses. The P.C.B., switches and fuses are all mounted on the back of a hinged drop down door which is on the front of the transfer panel.

Status Panel: The front of the door has the status panel and main control switch. This status panel has four indicator lamps as shown in Figure 9.7. They are "Mains Available" (amber), "Mains on Load" (green), "Generator on Load" (red), and "Generator Available" (amber). Pressing the Lamp Test Button located below these indicator lamps will illuminate them for testing.

Controls: The main control switch on the front panel has three positions:-

AUTOMATIC MODE - The normal position for automatic operation.

TEST WITHOUT LOAD - For testing the generator set without connecting the load.

TEST WITH LOAD - For testing the generator set with the load connected.

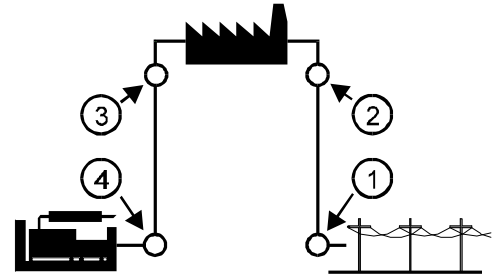

Item Description

1. "Mains Available" Status Lamp
2. "Mains on Load" Status Lamp
3. "Generator on Load" Status Lamp
4. "Generator Available" Status Lamp

Figure 9.7: TI Series Load Transfer Panel Status Display

In addition to the main control switch on the panel face, there is an internally mounted 3 position "Control Bypass" keyswitch for use by service personnel only. In the "normal" position the TI Panel operates normally. The other two positions allow the service personnel to manually connect the load to the operating generator set or to the mains supply. This switch would be used if the TI P.C.B. has been damaged.

WARNING:

! The internal maintenance switch should only be operated by trained personnel due to the high voltages present inside the enclosure.

Functional Description: The TI Series Load Transfer Panel operates as follows:

With the mains supplying electrical power to the load, the "Mains Available" and "Mains on Load" Status Lamps will be illuminated. These lamps indicate that the mains supply voltage level is above the Mains Voltage Set point (MVS) on the P.C.B. and that the load is connected to the mains supply. Potentiometer MVS is factory set at the voltage trip point for all three phases.

When the mains voltage on any of the 3 phases drops below the trip level MVS, both the "Mains Available" and "Mains on Load" status lamps extinguish. The Delay on Start timer (2MT) is energized. This timer avoids false engine starts due to momentary mains fluctuations. If the mains have not returned by the time 2MT has timed out then the mains contactor is opened and a start signal is sent to the generator set control panel.

Once the generator set has started and is producing voltage the "Generator Available" status lamp is illuminated and the Delay on Transfer Timer (AT) is enabled. This timer permits alternator output to stabilize before the standby contactor is closed. Once AT has timed out, and as long as the generator set voltage is above the Generator Voltage Set point (GVS), then the standby contactor is closed. This allows the generator set to power the load. The "Generator on Load" status lamp will be illuminated at this time.

On restoration of mains power above the trip point MVS, the "Mains Available" status lamp will illuminate and the Delay on Retransfer Timer (1MT) will be energized. This timer allows a period of time to ensure that the mains supply is reliable before transferring the load back. If the mains voltage drops below MVS at any time during this period then 1MT will be reset and not restarted until the mains voltage again goes above MVS.

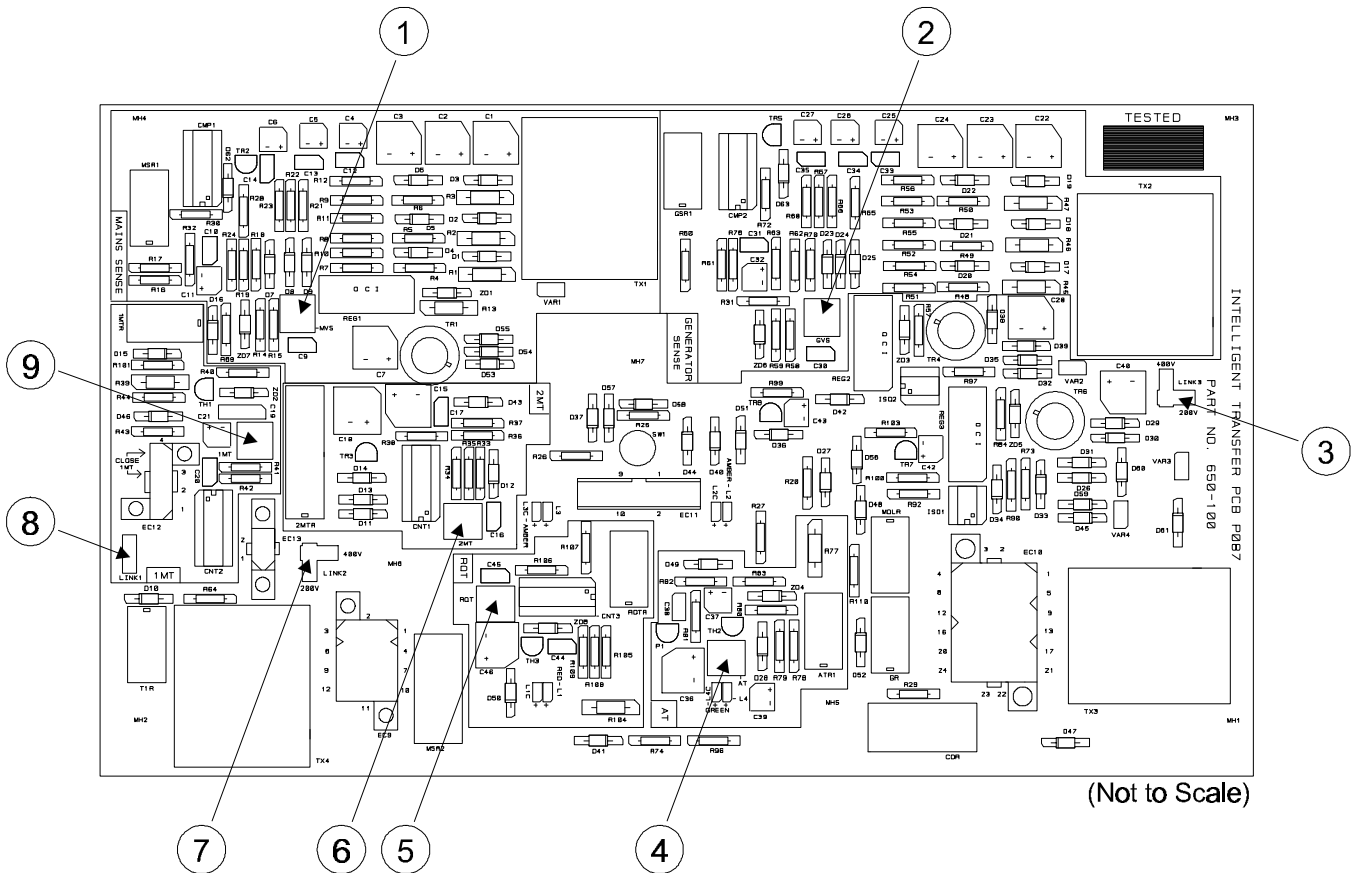

- | Item | Description | Item | Description |
|------|---------------------------------------------------------------------------------------|------|-------------------------------------------------------------------------------------|
| 1. | MVS: Mains Voltage Set
(Factory Set) | 6. | 2MT: Delay on Start Timer
Range: 1-25 seconds |
| 2. | GVS: Generator Voltage Set
(Factory Set) | 7. | LINK 2: Operating Voltage Range Select |
| 3. | LINK 3: Operating Voltage Range Select | 8. | LINK 1: Remove for Manual Retransfer Operation |
| 4. | AT: Delay on Transfer Timer
(Factory Set) | 9. | 1MT: Delay on Retransfer Timer
Range: 160 seconds-28 minutes
Set: 160 seconds |
| 5. | ROT: Run on Timer (cool down period)
Range 23-315 seconds
Set: 240 ± 15 seconds | | |

Figure 9.8: Layout of TI Series Load Transfer Panel P.C.B.

After 1MT times out, the standby contactor is opened and the "Generator on Load" status lamp is extinguished. The mains contactor is then closed and the "Mains on Load" status lamp is illuminated. The load is now powered by the mains supply. The Run on Timer (ROT) is also energized at this point to allow the generator set to continue running and cool down at no load before stopping. After ROT times out the start signal is removed and the generator set automatically shuts down. The "Generator Available" status lamp extinguishes.

Configuring the TI P.C.B. for Different Supply Voltages:
The TI P.C.B. operates in most systems from 190 volts to 480 volts phase to phase, 50 and 60 Hz and both single and 3 phases. Only a qualified technician should reconfigure the TI P.C.B. by moving links on the P.C.B. and wiring looms in addition to fitting additional fuses. Procedures for these changes are available from the factory.

Adjustment of MVS and GVS: These potentiometers control the trip points for the mains and generator voltage respectively. They are usually both set to the same values. These potentiometers are multi-turn type. Either of two types may be fitted:- round types have 4 turns, rectangular types have 15 turns.

It is possible for a qualified technician to reset these levels on site. Procedures for resetting these potentiometers are available from the factory.

Manual Retransfer Option: If fitted, this allows the operator to manually control the timing of the retransfer of the load from the generator set to the restored mains supply. The controls comprise a Manual/Auto Retransfer Selector Switch and a Retransfer Button. This option connects to the 4 pin connector EC12 on the TI P.C.B.

With the Retransfer Selector Switch in Manual or Auto, on mains failure the generator set will start and accept load in the normal sequence. With the switch in Auto, the load will be automatically retransferred back to the mains when available as described above.

With the Retransfer Selector Switch in Manual, the retransfer timer is bypassed and, on restoration of the mains, the "Mains Available" indicator will illuminate but the generator will continue to supply the load. When it is convenient for the retransfer to take place, the operator presses the Retransfer Button which causes the standby contactor to open and the mains contactor to close. This reconnects the load to the mains.

The set will continue to run for the cool down period before automatically shutting down and resetting.

Optional Remote Status Indicating Lamps: If fitted, this option allows a remote indication of the status lamps that are mounted on the TI panel. A 10 way ribbon cable connected to connector EC11 on the TI P.C.B. sends the appropriate signals to a matching status display P.C.B.

9.7 Engine Interface Module Description

The Engine Interface Module is a sealed, engine mounted module that provides switching relays for the Starter Motor Solenoid, Glow Plug and Fuel Solenoid. Each of these circuits is protected with individual fuses mounted in the module. Individual LED's illuminate when each circuit is energized.

This module is mounted on the engine with anti-vibration mounts and is easily connected to the engine via loom plugs. The fuses are automotive type. Use of the EIM means that heavy currents such as Fuel Solenoid power no longer go through the control panel enabling individual protection of each of the circuits. In addition to this the LED's will greatly aid in fault finding.

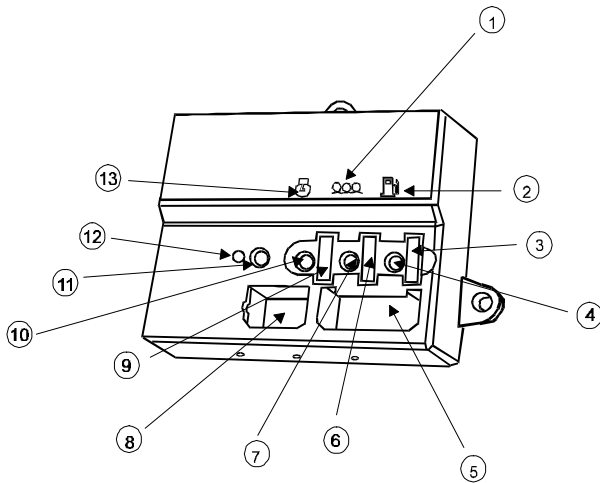

Item	Description	Item	Description
1.	Glow Plug Symbol	8.	Secondary Socket
2.	Fuel Symbol	9.	Starter Solenoid Fuse
3.	Fuel Solenoid Fuse	10.	Starter LED
4.	Fuel LED	11.	Overspeed Set-up LED
5.	Main Connector Socket	12.	Overspeed Adjuster
6.	Glow Plug Fuse	13.	Starter Symbol
7.	Glow Plug LED		

Figure 9.9: Engine Interface Module

9.7.1 Functional Description: There are three versions of the Engine Interface Module available - the 12 volt EIM SR, the 12 volt EIM Plus and the 24 volt EIM Plus.

The EIM SR is the basic level module that provides all the switching functionality. The EIM Plus provides the same functionality as the EIM SR plus the additional feature of Overspeed Sensing and an Overspeed Trip Adjuster. A magnetic pick-up on the engine flywheel housing provides the speed signal to the EIM Plus. When an overspeed situation is sensed, the EIM Plus signals the 2001, 4001 or 4001E generator set control panel to stop the engine. The Overspeed Trip Point can be easily set-up for 10% above the normal operating speed.

The overspeed feature on the EIM Plus, including the magnetic pickup is mandatory for all the Autostart control panels (2001, 4001 and 4001E). All generator sets above 150 kVA (with 24 volt engine electrical systems) are supplied with the EIM Plus and magnetic pickup as standard.

Status Indication: LED's on the module correspond to the Starter Motor Solenoid supply, the Glow Plug supply (where used) and the Fuel Control Solenoid supply. Each illuminates to show that the indicated circuit is energized. A fourth LED (only operational on the EIM Plus) is used to set-up the Overspeed Trip Point.

Starter Motor Solenoid (EIM SR): When the Keyswitch is turned to start, a relay in the module is energized providing power to the Starter Motor Solenoid. When the Keyswitch is released the relay is de-energized, stopping the starter motor.

Starter Motor Solenoid (EIM Plus): During automatic cranking the module receives a signal from the magnetic pick-up. When the signal rises above 1090 Hz, the starter motor is disengaged and the EIM Plus switches a zero volt signal to the generator set control panel to indicate that the engine is running.

Should the crank speed be less than 12 Hz, the module will only allow a crank of 0.6 seconds.

If the engine speed falls below 350 Hz (i.e. the engine has stopped) the EIM Plus will allow cranking only after a 5 second delay (lockout) which compliments the generator set control panel's 3 attempt crank.

Glow Plug (pre-heat): When the relay is energized power is provided to the Glow Plug (where fitted).

Fuel Control Solenoid: The generator set control panel energizes a relay in the module that provides power to the Fuel Control Solenoid allowing fuel flow to the engine.

Overspeed Signal (EIM Plus only): The EIM Plus monitors the speed signal from the magnetic pick-up. If the engine speed rises above a certain pre-settable value, the module sends a zero volt signal to the generator set control panel to activate the Overspeed Fault circuitry.

The Overspeed Set Point is factory set at 55Hz for 50Hz sets and 66Hz for 60Hz sets. This can be adjusted using the adjustment screw accessed through the hole beside the Overspeed Set-Up LED. While the engine is running at the rated speed (1500 rpm for 50Hz or 1800 rpm for 60Hz) the adjustment screw should be adjusted until the Overspeed Set-Up LED just goes out. This sets the overspeed value at 10% above the speed at which the generator set is operating.

Safety "Relay" Feature: The EIM SR and EIM Plus provide a safety check for any damaged contacts (i.e. welded contacts) using a "safety" relay. When the emergency stop pushbutton on the generator set control panel is pushed the EIM module automatically checks Fuel Control Solenoid and Starter Motor Solenoid to see if they are welded shut. A dimly lit LED on the module indicates the contacts are damaged and the module should be replaced.

9.8 Output Circuit Breaker Description

The alternator output circuit breaker is a molded case circuit breaker (MCB/MCCB) of sufficient rating for the generator set output. Electrical output is switchable through this device, with "ON" being indicated by the handle being up. The breaker will carry its rated current continuously but will trip to mid-position if the rating on any one phase is exceeded for a period depending on the percentage overload and the circuit breaker characteristics. The breaker must then be switched "OFF" (handle down) before reclosing.

10. BATTERY DESCRIPTION AND MAINTENANCE

10.1 Battery Theory

10.1.1 General: The battery is an assembly of "cells" containing a number of plates, immersed in an electrically conductive fluid. The electrical energy from the battery comes from chemical reactions taking place within the cells. These reactions are reversible which means that the battery can be repeatedly charged and discharged.

10.1.2 Electrolyte: The electrically conductive fluid, called electrolyte, in a lead-acid battery is a diluted sulphuric acid solution. It aids the chemical reactions occurring at the plates and it acts as the carrier for the electrical current.

10.1.3 Specific Gravity: Specific gravity is a unit of measurement for determining the sulphuric acid content of the electrolyte which compares the weight of the electrolyte compared to the weight of pure water. At 25°C (77°F) a fully charged battery should have a specific gravity of 1.270. The lower the concentration of sulphuric acid, the lower the specific gravity.

As the battery is discharged, the chemical reactions lower the specific gravity of the electrolyte. Therefore, this measurement can be used as a guide to the state of charge of the battery.

10.1.4 Hydrometer: Specific gravity can be measured directly using a hydrometer. This device is a bulb-type syringe which will extract electrolyte from a cell in the battery. A glass float in the hydrometer barrel is calibrated to indicate the specific gravity.

Hydrometer readings should not be taken immediately after water is added to the cell. The water must be thoroughly mixed with the underlying electrolyte, by charging, before hydrometer readings are reliable. Also, if the reading is being taken immediately after the battery has been subjected to prolonged cranking, the reading will be higher than the true value. The water formed in the plates during the rapid discharge will not have had time to mix with the electrolyte above the plates.

10.1.5 High or Low Temperatures: In tropical climates (frequently above 32°C (90°F)) a fully charged battery with a lower specific gravity of 1.240 is used. This milder strength electrolyte increases the service life of the battery. If subjected to low temperatures the battery will not have the same cranking power due to the lower concentration of sulphuric acid, but this situation should not occur in tropical climates.

Batteries prepared for service in extremely cold weather use stronger electrolyte. In some instances specific gravity's of 1.290 to 1.300 are used. The cold cranking performance increases as the specific gravity increases.

10.1.6 Temperature Correction: The hydrometer is calibrated to indicate properly for a specified electrolyte temperature, often 25°C (77°F). For temperatures higher or lower than the reference temperature, a correction must be made. For each 5.5°C (10°F) above the reference add 0.004 to the reading. For each 5.5°C (10°F) below the reference, subtract 0.004 from the reading.

10.2 Battery Maintenance

WARNING:

! **Wear an acid resistant apron and face shield or goggles when servicing the battery. If electrolyte is spilled on skin or clothing, flush immediately with large quantities of water.**

10.2.1 Filling: The battery will often be shipped dry. Pre-mixed electrolyte of the correct specific gravity will have to be added.

Remove the vent plugs and fill each cell with the electrolyte until the level is 8 mm (5/16 inch) above the top edge of the separators. Allow the battery to stand for 15 minutes. Check and adjust the level as necessary.

10.2.2 Initial Charging: Within 1 hour of filling, the battery must be charged for 4 hours at the current indicated below. This will ensure that the acid is sufficiently mixed within the battery. Failure to give this charge at this time may impair the capacity of the battery.

Battery Reference	Charge Current (Amps)
E017	9
E312	14
E324	20

The above 4 hour charge period may need to be extended as follows: to 8 hours if the battery has been stored for 3 months or more at temperatures in excess of 30°C (86°F) or humidity above 80%; to 12 hours if the storage has exceeded 1 year.

If the charger output is not sufficient then a lower current, which should not be less than 1/3 of that given above, may be used but the time increased in proportion (8 hours at 7 Amps instead of 4 hours at 14 Amps).

At the end of the charging period, the electrolyte levels should be checked and restored if necessary by addition of sulphuric acid electrolyte at the correct specific gravity. The vents should then be replaced.

10.2.3 Topping Up: Normal operation and charging of the battery will cause some of the water to evaporate. This will require occasional topping up of the battery.

Clean the battery first to avoid contamination and remove the vent plugs. Add distilled water, until the level is 8 mm (5/16 inch) above the separators. Replace vent plugs.

10.3 Charging the Battery

WARNING:

- ! **Always ensure battery charging is carried out in a well ventilated area away from sparks and naked flames.**
- ! **Never operate a battery charger where unprotected from rain or snow. The charger should never be used near water.**
- ! **Always switch the charger off prior to disconnecting the battery.**

The engine driven alternator and or a static battery charger, if fitted, should maintain the batteries in a charged state. However, if the battery has recently been filled or recharging is required the battery may be disconnected from the generator set and connected to an external battery charger.

10.3.1 Charger and Battery Connections: The battery charger should be connected to a suitable mains supply (13 Amps minimum) using a plug connected as indicated below.

Mains Connection

Live	Brown Lead
Neutral	Blue Lead
Earth	Green/Yellow Lead

Also ensure that the battery terminals are connected as indicated below:

Battery Connection

Positive (+) Terminal	Red Lead
Negative (-) Terminal	Black Lead

Connect the batteries to the charger as per the following chart:

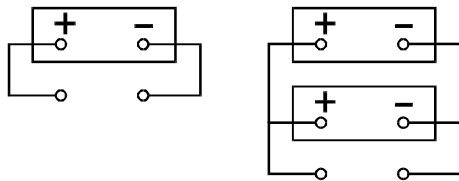

Single Battery

Parallel

12 Volt Systems

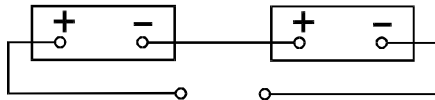

Series

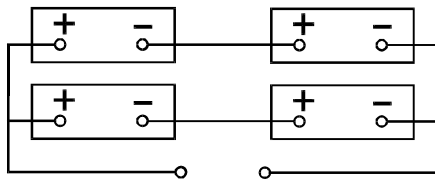

Series/Parallel

24 Volt Systems

10.3.2 Charger Operation: After the charger has been connected to the mains and the battery connected to the charger as indicated above, the charging procedure can be followed:

Remove the battery filler caps or vent cover during charging. Check electrolyte levels and adjust as necessary using distilled water.

Switch on the charger and observe rate of charge for normal operation. The charging rate depends on the Ampere-hour capacity of the battery, the condition of the battery and the present level of charge. The charging current will decrease as the battery starts charging and will continue to decrease as the battery voltage rises.

To check the state of charge, allow the battery to settle for a short period with the charger switched off. Then check the specific gravity of each cell using a hydrometer.

The battery charger should not overcharge or damage the batteries. High temperature, however, can damage the batteries. Care should be taken when charging batteries, especially in hot climates, that the battery temperature never rises above 45°C (113°F).

10.4 Battery Charging System Fault Finding/Trouble Shooting Chart

WARNING:

! Removal of the battery charger cover will expose dangerously high voltage terminals.

Symptom	Possible Fault	Remedy
No Charging Current	Incorrect or Bad Battery Connections	1. Check connections and clean terminals.
	Old or Sulfated Battery with Very Low Terminal Voltage	1. Remove battery and charge on specialist equipment.
	No Mains Supply	1. Check mains supply to charger.
	Blown Mains Fuse	1. Replace fuse.
	Faulty Diode Rectifier Unit	1. Remove output connections from each rectifier unit and test for output current into a known load.
No Charging Current Shown on Indicator	Faulty Indicator	1. Check charging current with standard ammeter.
Charging Rate Too Low	Low Mains Voltage	1. Check mains voltage supply.
	Incorrect Mains Supply Tapping	1. Check the mains supply tapping with the supply voltage.
	Loose Heavy Current Connections	1. Check and tighten connections if necessary.
Charging Clamps Get Hot	Faulty Connections to the Battery	1. Clean terminals and reconnect.
	Loose Screws in Clamps	1. Clean and tighten screws in charging clamps.
Mains Supply Fuse Blows Repeatedly	Incorrect Fuse Rating	1. Replace with correct fuse.
	Wiring Short	1. Check and remake all connections.
Charging Rate Does Not Taper	Old or Damaged Battery	1. Charger is not faulty - battery will not rise to full charge voltage. Test battery and replace as necessary.

10.5 Jump Starting Procedures

WARNING:

- !** Do not attempt to jump start a battery if the electrolyte is frozen or slushy. Bring the batteries up to at least 5°C (41°F) before attempting a jump start.

If the generator set battery has insufficient charge to start the generator set, a "jump start" from another battery is possible. Use the following procedures:

1. Remove all vent caps from the battery or batteries in the generator set. Do not permit dirt or foreign matter to enter the open cells.
2. Check the battery fluid level. If low add distilled water to bring it to the proper level.
3. Attempt to jump start only with a vehicle with a negative ground electrical system with the same voltage and that is equipped with a battery or batteries of comparable size or larger than those supplied with the generator set.
4. Bring the starting vehicle along side the generator set but do not allow metal to metal contact.
5. Place the starting vehicle in neutral or park, turn off all non-essential accessory loads and start the engine.
6. Connect one end of clean, heavy duty jumper cables to the positive battery terminal of the starting vehicle. If jump starting a 24 volt generator set and the starting vehicle is provided with two 12 volt batteries, then connect the jumper cable to the positive terminal of the battery that is not grounded.
7. Connect the other end of the same jumper cable to the positive terminal of the battery in the generator set. When jump starting 24 volt generator sets, connect to the positive terminal of the battery that is not grounded.
8. Connect one end of the other jumper cable to the grounded negative terminal of the battery in the starting vehicle. If jump starting a 24 volt generator set and the starting vehicle is provided with two 12 volt batteries, then connect the jumper cable to the negative terminal of the battery that is grounded.
9. Check the connections. Do not attempt to start a 24 volt generator set with one 12 volt battery in the starting vehicle. Do not apply 24 volts to one 12 volt battery in the generator set.
10. Connect the other end of this second jumper cable to a clean portion of the generator set engine block, away from fuel lines, the crank case breather opening or the battery.
11. With the engine of the starting vehicle running, start the generator set in accordance with the normal procedures. Avoid prolonged cranking.
12. Allow the generator set to warm up. When the set is warm and operating smoothly at normal RPM, disconnect the negative jumper cable from the engine block on the generator set. Then disconnect the other end of the same cable from the battery in the starting vehicle. Then disconnect the other cable for the positive terminal of the generator set battery and finally disconnect the cable from the starting vehicle battery.
13. Replace vent caps.

HAZARD LABEL LEGEND

Some or all of these hazard warning labels will appear on your generator set:

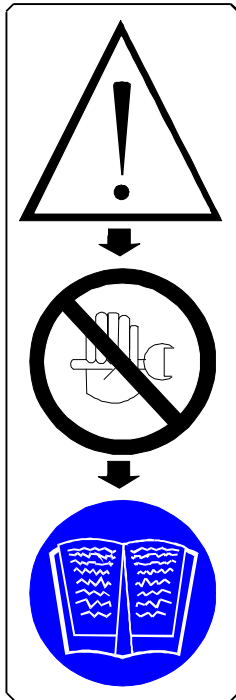

DO NOT TAMPER WITH
UNLESS YOU HAVE
READ THE
INSTRUCTION
MANUAL

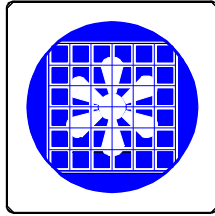

USE FAN GUARDS

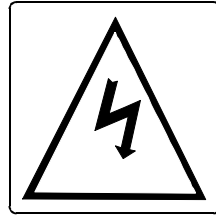

ELECTRIC SHOCK
HAZARD

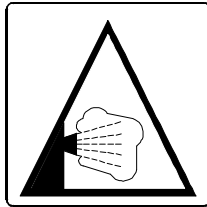

HOT EXHAUST
GAS

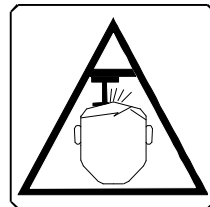

LOW OVERHEAD
OBJECTS

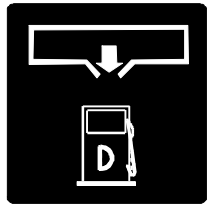

DIESEL FUEL
SUPPLY LINE

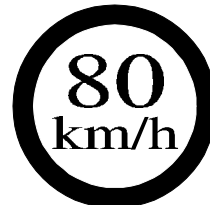

RATED SPEED

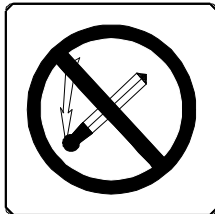

NO NAKED FLAMES

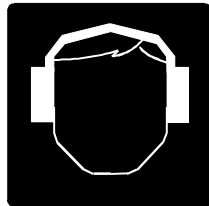

WEAR EAR
PROTECTION



EMERGENCY/
PANIC EXIT

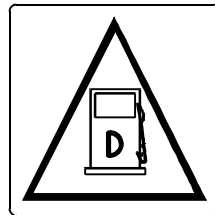

DIESEL FUEL
WARNING



HOT SURFACES

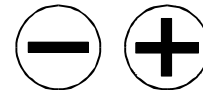

ELECTRIC TERMINALS

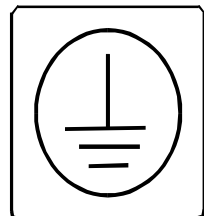

PROTECTIVE EARTH
(GROUND)

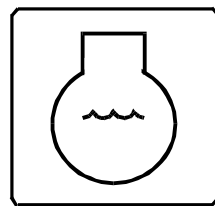

ENGINE COOLANT

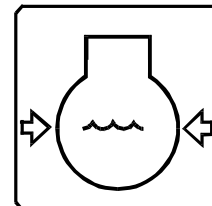

ENGINE COOLANT
PRESSURE

INDEX

Acoustic Silencing	12	Fuel Transfer Pumps	31
Air Flap Valve	19	Gauges	31
Air Inlet.....	8	General Description	5
Air Inlet/Exit.....	8	General Safety	1
Alarm Signalling.....	31	Generating Set Maintenance	18
Alternator	5	Grounding.....	12
Alternator Description.....	21	Handling	6
Alternator Maintenance	21	Handling Safety	1
Alternator Method of Operation	21	Heaters	30
Alternator Reconnection.....	12	Hours Run Meter.....	22
Alternator Removal.....	18	Identification	5, 22
Alternator Storage	13	Installation	6
Ammeter	22	Installation Safety.....	1
Automatic Voltage Regulator	21	Insulation Test.....	12, 21
Baseframe	5	Jump Starting	41
Basetank.....	5, 10	Key Switch.....	24
Batteries.....	11, 39	Load Transfer Panels.....	36
Battery Charger	39	Locating the Generating Set.....	6
Battery Charger Trouble Shooting.....	40	Maintenance	
Battery Charging Fault Finding	40	Engine	19
Battery Maintenance	39	Generating Set.....	18
Battery Storage.....	13	Mechanical Safety.....	2
Battery Trickle Chargers	30	Meters	31
Battery Voltmeter.....	22	Moving the Generating Set.....	6
Bulk Storage Tanks	10	Noise Safety	2
Cabling.....	12	Oil Pressure Gauge.....	22
Chemical Safety	2	P.C.B.	24, 25, 36
Circuit Breaker.....	5, 22, 38	Panel Equipment.....	22
Cleaning.....	18, 19, 21	Parallel Running.....	12
Combustion Air.....	8	Parking.....	13
Control Panel		Power Factor	12
1001 Series.....	23	Pre-Start Checks.....	14
2001 Series.....	23	Preventative Maintenance	18
4001 Series.....	23	Radiator Maintenance.....	19
4001E Series	23	Rating Label	5
Control System	5, 14, 22	Remote Annunciator Panels.....	31
1001 Series Panel	24	Safety.....	1
2001, 4001, 4001E Series Panels	25	Chemical	2
Cooling.....	8	Electric Shock	3
Cooling System	5, 19	Electrical	2
Day Tank	10	Fire and Explosion.....	1
Electric Shock.....	3	First Aid.....	3
Electrical Connection.....	12	Handling.....	1
Electrical Grounding.....	12	Installation.....	1
Electrical Loading.....	12	Mechanical.....	2
Electrical Protection.....	12	Noise	2
Electrical Safety.....	2	Towing.....	1
Emergency Stop.....	24	Shutdown	
Enclosures	6, 12	1001 Series Panel	15, 16
Engine	5	2001, 4001, 4001E Series Panels	17
Engine Description	19	Sound Attenuation.....	12
Engine Electrical System	5	Speed Control	31
Engine Governing.....	19	Spreader Bar	6
Engine Maintenance.....	19	Starting Aids	19
Engine Removal	18	Startup	
Engine Storage	13	1001 Series Panel	14, 15
Ethyl Ether.....	19	2001, 4001, 4001E Series Panels	16, 17
Exhaust Silencer/Muffler	5, 12	Storage	13
Exhaust System.....	5, 9, 19	Thermostart Preheat	24
Explosion Safety.....	1	TI Intelligent Load Transfer Panel	36
Fault Finding.....	32	Towing	12
Fault Lamps.....	24	Towing Safety.....	1
Fire Safety.....	1, 11	Trouble Shooting.....	32
First Aid.....	3	Ventilation.....	8
Foundation.....	7	Vibration Isolation.....	5, 7, 10, 12
Frequency Meter	22	Voltage Control.....	31
Fuel System.....	10, 19	Voltmeter	22
Fuel Tank.....	5	Water Temperature Gauge.....	22