Perkins

Peregrine EDi and 1300 Series EDi

Models WK to WN

WORKSHOP MANUAL

Peregrine **6 cylinder turbocharged diesel engines with electronic management system for automotive applications**

1300 Series **6 cylinder turbocharged diesel engines with electronic management system for agricultural and industrial applications**

This publication is written in
Perkins Approved Clear English

PACE

Contents

10A General information

Introduction	13
Engine identification	15
Safety	16
POWERPART recommended consumable products	18

11A Specifications

Basic engine data	21
Recommended torque settings	22
Specific torques	23

12A Cylinder head assembly

General description	25
Rocker cover	
12A-1 To remove and to fit	26
Engine breather elements	
12A-2 To renew	28
Rocker assembly	
12A-3 To remove and to fit	29
12A-4 To dismantle and inspect	31
12A-5 To assemble	32

Cylinder head

12A-6	To remove and to fit...	33
-------	-------------------------	----

Valves and valve springs

12A-7	To remove and to fit...	36
12A-8	To inspect and to correct...	37
12A-9	To inspect a valve rotator ..	38

Valve guides

12A-10	To inspect a valve guide ..	39
12A-11	To remove and to fit...	39

Cylinder head

12A-12	To inspect and to correct...	41
12A-13	To correct a valve seat with a valve seat cutter.	42
12A-14	To fit valve seat inserts..	43
12A-15	To renew injector unit sleeves ..	44
12A-16	To set the valve tip clearance ..	46

Data and dimensions

13A Piston and connecting rod assemblies

General description

Big end bearing

13A-1	To remove and to fit...	52
13A-2	To inspect..	53

Piston and connecting rod assembly

13A-3	To remove and to fit...	54
13A-4	To dismantle and assemble (WK and WL engines) ..	56
13A-5	To dismantle and assemble (WM and WN engines) .	57
13A-6	To inspect..	58

Connecting rod

13A-7	To inspect..	59
-------	--------------	----

Small end bush

13A-8	To remove and to fit...	59
-------	-------------------------	----

Piston rings

13A-9	To remove and to fit...	60
13A-10	To inspect..	60

Data and dimensions	61
----------------------------------	----

14A Crankshaft assembly

General description	63
14A-1 To remove and to fit	64
14A-2 To inspect	65

Rear oil seal housing assembly

14A-3 To remove and to fit the oil seal housing	66
14A-4 To renew the rear oil seal and wear sleeve assembly	69

Crankshaft

14A-5 To remove and to fit	71
14A-6 To inspect	75

Crankshaft gear

14A-7 To renew	76
----------------------	----

Thrust bearing

14A-8 To check crankshaft end-float	77
14A-9 To remove and to fit	77

Main bearings

14A-10 To remove and to fit	79
14A-11 To inspect	80

Data and dimensions	81
----------------------------------	----

15A Timing case and drive assembly

General description	83
----------------------------------	----

Timing case cover

15A-1 To remove and to fit	85
----------------------------------	----

Idler gears

15A-2 To remove and to fit	86
----------------------------------	----

Timing case backplate

15A-3 To remove and to fit	88
----------------------------------	----

Camshaft and tappets

15A-4 To remove and to fit	90
15A-5 To inspect	91

Camshaft bushes

15A-6 To renew	92
----------------------	----

Data and dimensions	93
----------------------------------	----

16A Cylinder block assembly

General description	95
----------------------------------	----

Cylinder block

16A-1 To dismantle and to assemble.....	96
16A-2 To inspect.....	96

Cylinder liner

16A-3 To remove and to fit.....	97
16A-4 To inspect.....	99

Data and dimensions	100
----------------------------------	-----

17A Engine timing

General description	101
----------------------------------	-----

17A-1 To set number one cylinder to TDC on the compression stroke	101
17A-2 To check the valve timing (with a feeler gauge)	102
17A-3 To check the valve timing (with a dial test indicator)	102

18A Turbocharger

General description	103
----------------------------------	-----

18A-1 To remove and to fit.....	104
18A-2 To dismantle and to assemble.....	106
18A-3 To inspect.....	108
18A-4 To clean the impeller and compressor casing.....	108
18A-5 To remove and to fit the actuator assembly of the waste-gate unit.....	109
18A-6 To check and to adjust the actuator assembly of the waste-gate unit.....	111

Turbocharger faults	114
----------------------------------	-----

Data and dimensions	116
----------------------------------	-----

19A Lubrication system - low-pressure

General description	118
Filter canister	
19A-1 To renew the canister of the lubricating oil filter	120
Filter head and oil cooler assembly	
19A-2 To remove and to fit	121
19A-3 To inspect	122
Oil temperature / pressure control valve	
19A-4 To remove and to fit	123
19A-5 To test	123
Pressure regulating valve	
19A-6 To remove and to fit	124
19A-7 To inspect	124
Sump	
19A-8 To remove and to fit	125
Oil strainer and suction pipe	
19A-9 To remove and to fit	127
Lubricating oil pump	
19A-10 To remove and to fit	128
19A-11 To inspect	131
Front oil seal	
19A-12 To renew	132
Pressure relief valve	
19A-13 To remove and to fit	133
19A-14 To inspect	133
Breather system	
19A-15 To clean	134
Data and dimensions	135

19B Lubrication system - high-pressure

General description	137
Sensor for injection control pressure	
19B-1 To remove and to fit.....	139
High-pressure pump	
19B-2 To remove and to fit.....	140
Regulator valve for injection control pressure	
19B-3 To remove and to fit.....	141
Supply manifold	
19B-4 To remove and to fit.....	142
Data and dimensions	143

20A Fuel system

General description	145
Fuel filter	
20A-1 To renew the fuel strainer and the canister of the fuel filter.....	148
Fuel injector units	
20A-2 To renew an injector unit.....	149
20A-3 To renew the injector unit seals.....	154
Fuel lift pump	
20A-4 To remove and to fit.....	155
20A-5 To dismantle and assemble.....	156
20A-6 To set the adjustment of the speed control	157
20A-7 To eliminate air from the fuel system.....	158
Data and dimensions	159

21A Cooling system

General description	162
21A-1 To renew the canister of the coolant filter/ inhibitor.....	164
Thermostat	
21A-2 To remove and to fit.....	165
21A-3 To test	165

Coolant pump	
21A-4 To remove and to fit..	166
Fan	
21A-5 To remove and to fit..	167
Fan drive	
21A-6 To remove and to fit..	167
Fan drive belt	
21A-7 To remove and to fit..	168
Data and dimensions	169

22A Flywheel and housing

General description	171
Flywheel	
22A-1 To remove and to fit..	171
Ring gear	
22A-2 To remove and to fit..	172
Flywheel housing	
22A-3 To remove and to fit..	173
Data and dimensions	174

23A Electrical equipment

Alternators	175
General description	175
23A-1 To remove and to fit..	176
23A-2 To maintain ..	176
23A-3 Fault diagnosis..	177
Wiring diagrams	178
Data and dimensions	179

Starter motors

General description	180
23A-4 To remove and to fit...	180
23A-5 To maintain	180
23A-6 To test on the engine.	181

Wiring diagrams	182
------------------------------	-----

Data and dimensions	183
----------------------------------	-----

Starting aid

General description	184
----------------------------------	-----

Engine management system

General description	185
----------------------------------	-----

Sensors	186
----------------------	-----

Wiring diagram	187
-----------------------------	-----

24A Auxiliary equipment

Compressors

General description	191
----------------------------------	-----

Operation	191
------------------------	-----

24A-1 To remove and to fit...	192
-------------------------------	-----

Power steering pump

24A-2 To remove and to fit...	193
-------------------------------	-----

Power take-off adaptor

24A-3 To remove and to fit...	194
-------------------------------	-----

24A-4 To tighten the drive gear nut..	194
---------------------------------------	-----

25A Special tools

List of special tools	195
------------------------------------	-----

26A Fault diagnosis

General description	199
----------------------------------	-----

Basic diagnostics

The self-test system

26A-1	How to check for faults codes	201
26A-2	How to test for an open circuit	201

The diagnostic tool

26A-3	General description	202
26A-4	The diagnostic program map	203
26A-5	Code display options	205
26A-6	The engine data list	206
26A-7	How to connect the diagnostic tool	208
26A-8	How to check for faults codes	209
26A-9	How to clear faults codes from the diagnostic tool	210
26A-10	How to do the "ENGINE OFF TEST"	211
26A-11	How to do the "ENGINE RUNNING TEST"	213

Flash codes		215
--------------------	--	-----

10A

General information

Introduction

The Peregrine EDi and the 1300 Series EDi is a family of turbocharged engines that have an electronic management system. The Peregrine EDi engines are designed for automotive applications and the 1300 Series EDi engines are designed for industrial and agricultural applications. The Peregrine EDi and the 1300 Series EDi engines are from Perkins Engines Limited, a world leader in the design and manufacture of high-performance diesel engines.

Perkins approved assembly and quality standards, together with the latest technology, have been applied to the manufacture of your engine to give you reliable and economic power.

Most of the general information which is included in the relevant User's Handbook (sections 1 to 9) has not been repeated in this workshop manual and the two publications should be used together.

To ensure that you use the relevant information for your specific engine type, refer to "Engine identification" [on page 15](#).

Where the information applies only to certain engine types, this is indicated in the text by use of the the engine model code letters, [see page 15](#).

When reference is made to the "left" or "right" side of the engine, this is as seen from the flywheel end of the engine.

Special tools have been made available and a list of these is given in section 25. Reference to the relevant special tools is also made at the beginning of each operation.

Data and dimensions are included at the end of each section.

Read and remember the "Safety precautions". They are given for your protection and must be used at all times.

Danger is indicated in the text by two methods:

Warning! *This indicates that there is a possible danger to the person.*

Caution: *This indicates that there is a possible danger to the engine.*

Note: Is used where the information is important, but there is not a danger.

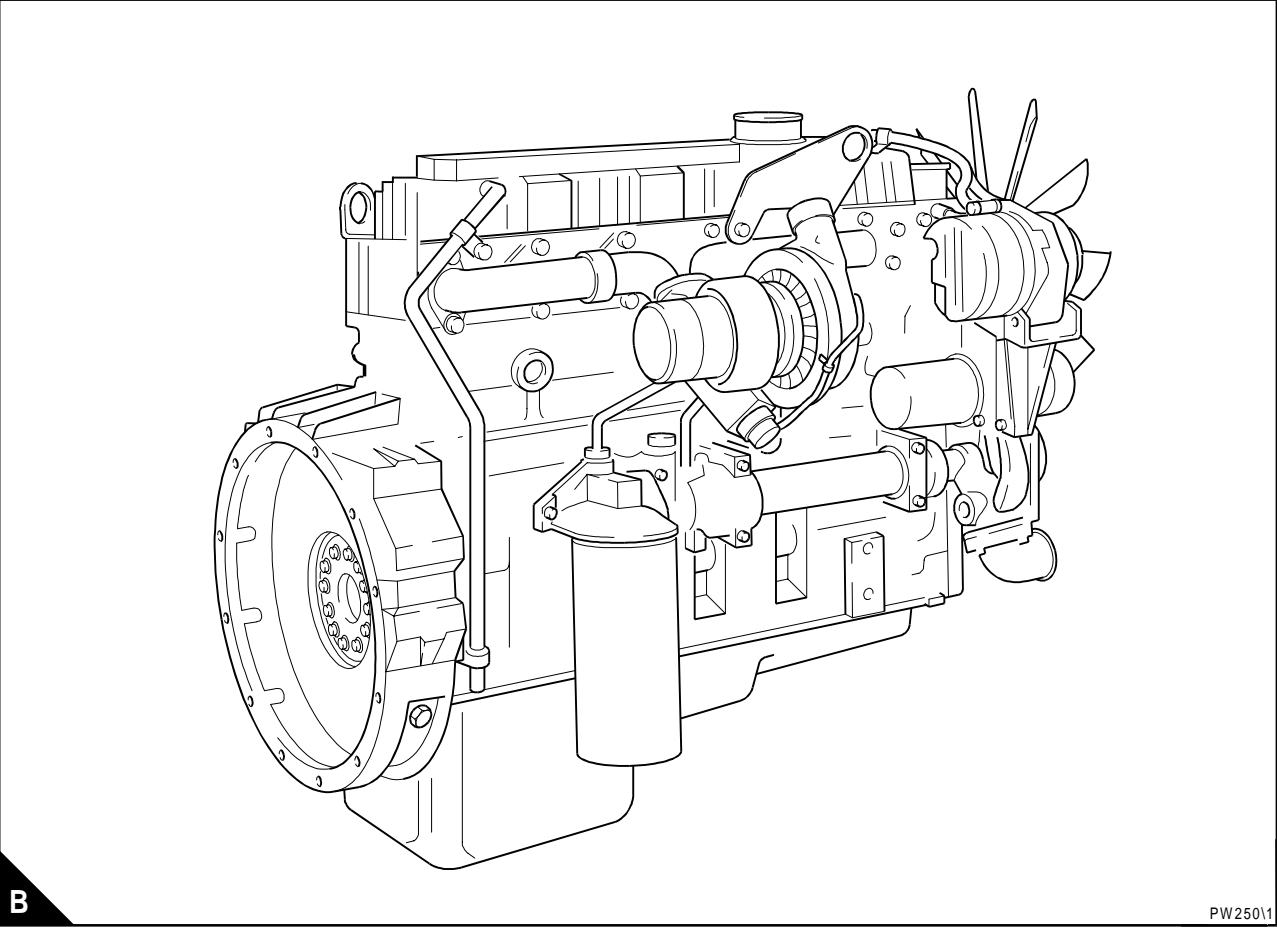
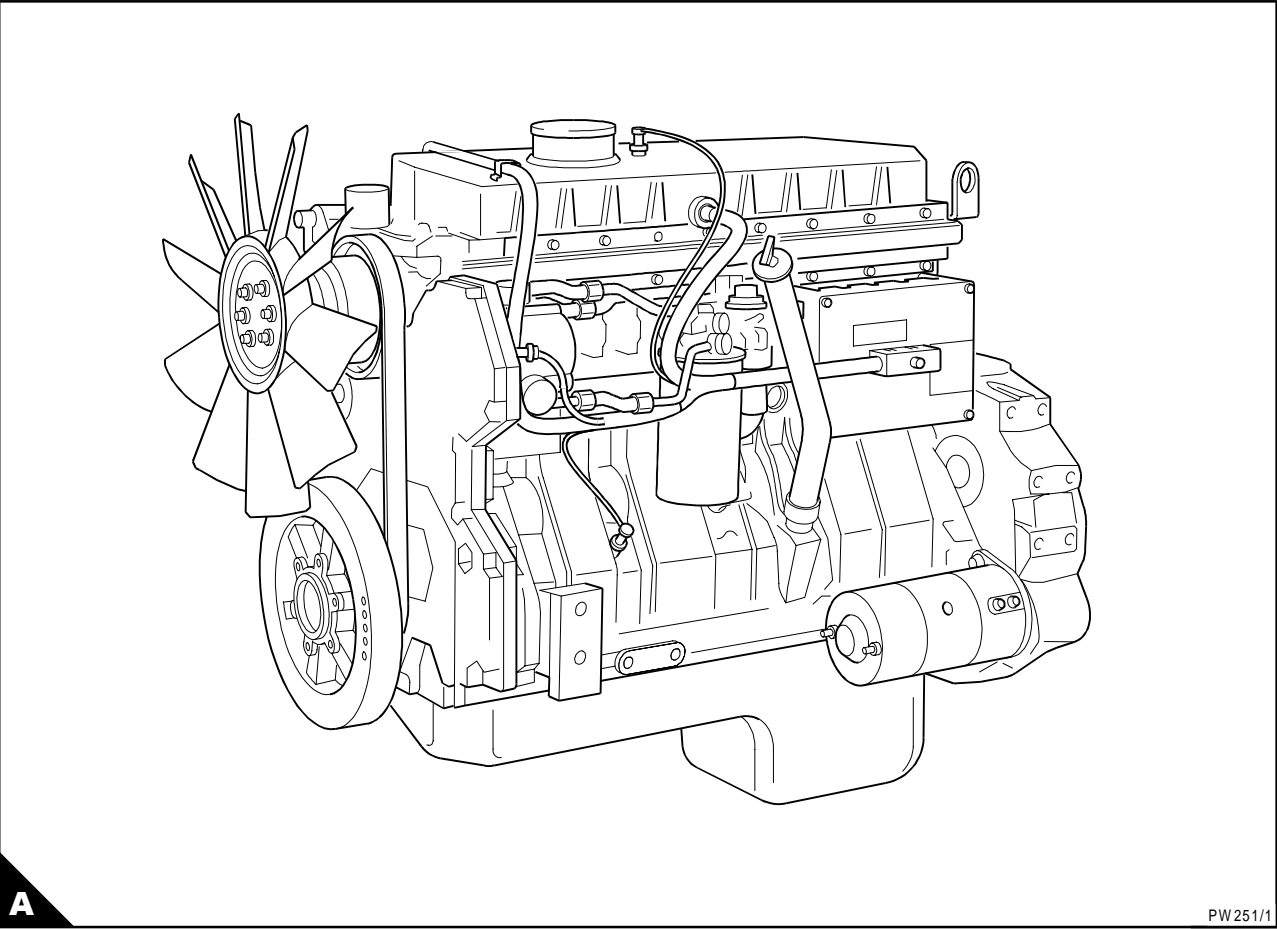

Engine identification

The engines consist of a range of six cylinder in-line engines which are turbocharged or turbocharged/intercooled. These engines have an electronic management system.

In this publication, the different engine types are indicated by their code letters, which are the first two letters of the engine number as indicated below:

Code letters	Capacity		Aspiration system
	Litre	in ³	
WK	7,6	466	Turbocharged
WL	7,6	466	Turbocharged / intercooled
WM	8,6	531	Turbocharged
WN	8,6	531	Turbocharged / intercooled

The engine number is stamped on the left side of the cylinder block (A1), behind the high pressure pump.

An example of an engine number is
WK1296N123456B.

The components of the engine number are as follows:

WK1296N123456B

WK	Model code letters
1296	Build list number
N	Built in the USA
123456	Engine serial number
B	Year of manufacture

If you need parts, service or information for your engine, you must give the complete engine number to your Perkins distributor.

Safety

General safety precautions

These safety precautions are important. You must refer also to the local regulations in the country of use. Some items only apply to specific applications.

- Only use these engines in the type of application for which they have been designed.
- Do not change the specification of the engine.
- Do not smoke when you put fuel in the tank.
- Clean away fuel which has been spilt. Material which has been contaminated by fuel must be moved to a safe place.
- Do not put fuel in the tank while the engine runs (unless it is absolutely necessary).
- Do not clean, add lubricating oil, or adjust the engine while it runs (unless you have had the correct training; even then extreme caution must be used to prevent injury).
- Do not make adjustments that you do not understand.
- Ensure that the engine does not run in a location where it can cause a concentration of toxic emissions.
- Other persons must be kept at a safe distance while the engine or auxiliary equipment is in operation.
- Do not permit loose clothing or long hair near moving parts.
- Keep away from moving parts during engine operation. **Warning!** *Some moving parts cannot be seen clearly while the engine runs.*
- Do not operate the engine if a safety guard has been removed.
- Do not remove the filler cap or any component of the cooling system while the engine is hot and while the coolant is under pressure, because dangerous hot coolant can be discharged.
- Do not use salt water or any other coolant which can cause corrosion in the closed coolant circuit.
- Do not allow sparks or fire near the batteries (especially when the batteries are on charge) because the gases from the electrolyte are highly flammable. The battery fluid is dangerous to the skin and especially to the eyes.
- Disconnect the battery terminals before a repair is made to the electrical system.
- Only one person must control the engine.
- Ensure that the engine is operated only from the control panel or from the operator's position. Discard used lubricating oil in a safe place to prevent contamination.
- Ensure that the control lever of the transmission drive is in the "out-of-drive" position before the engine is started.
- The combustible material of some components of the engine (for example certain seals) can become extremely dangerous if it is burned. Never allow this burnt material to come into contact with the skin or with the eyes.
- Diesel fuel and lubricating oil (especially used lubricating oil) can damage the skin of certain persons. Protect your hands with gloves or a special solution to protect the skin.
- Do not wear clothing which is contaminated by lubricating oil. Do not put material which is contaminated with oil into the pockets of clothing.
- Discard used lubricating oil in accordance with local regulations to prevent contamination.
- Use extreme care if emergency repairs must be made in adverse conditions.
- Always use a safety cage to protect the operator when a component is to be pressure tested in a container of water. Fit safety wires to secure the plugs which seal the hose connections of a component which is to be pressure tested.
- Do not allow compressed air to contact your skin. If compressed air enters your skin, obtain medical help immediately.
- Turbochargers operate at high speed and at high temperatures. Keep fingers, tools and debris away from the inlet and outlet ports of the turbocharger and prevent contact with hot surfaces.
- The fuel injector units of this engine are controlled electronically by a pulse of 110 volts.
- The fuel injector units are actuated by high-pressure engine lubricating oil. Do not remove any component of the high-pressure system while the engine oil is under pressure, because dangerous oil can be discharged.
- Fit only genuine Perkins parts.

Asbestos joints

The engines are asbestos free.

Engine lift equipment

- The maximum weight of the engine without coolant, lubricant or a gearbox fitted will vary for different applications, it is recommended that lift equipment with a minimum capacity of 770 kg (1700 lbs) is used:
- Always use engine lift equipment of the approved type and of the correct capacity, to lift the engine. It is recommended that lift equipment of the type shown in (A) is used, to provide a vertical lift directly above the engine lift brackets. Never use a single lift bracket to raise an engine.
- Check the engine lift brackets for damage and security before the engine is lifted.
- Use lift equipment or obtain assistance to lift heavy engine components such as the cylinder block, cylinder head, flywheel housing, crankshaft and flywheel.
- To avoid possible damage to the engine rocker cover by contact from the lift equipment, use the correct lift equipment (A) to raise the engine.

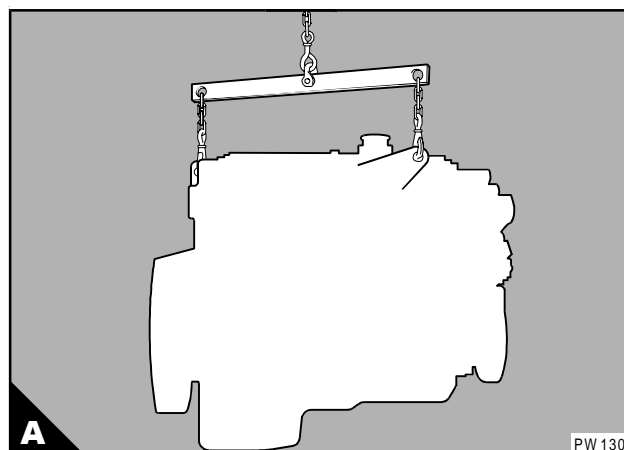

POWERPART recommended consumable products

Perkins have made available the products recommended below in order to assist in the correct operation, service and maintenance of your engine and your machine. The instructions for the use of each product are given on the outside of each container. These products are available from your Perkins distributor.

POWERPART Antifreeze

Protects the cooling system against frost and corrosion. Part number 1 litre 21825166 or 5 litres 21825167.

POWERPART Antifreeze

Protects the cooling system against frost and corrosion. Part number 1 litre 21825166 or 5 litres 21825167.

POWERPART Atomiser thread sealant

To seal the threads of the atomiser into the cylinder head. Currently Hylomar Advance Formulation.

POWERPART Chisel

Allows easy removal of old gaskets and joints. Currently Loctite chisel. Part number 21825163.

POWERPART Compound

To seal the outer diameter of seals. Currently Loctite Forma Gasket No 2. Part number 1861147.

POWERPART Easy Flush

Cleans the cooling system. Part number 2182501.

POWERPART Gasket eliminator

Improves flange sealing when a gasket is not used. It provides a seal with temperature resistance that is flexible in positions where vibration and pressure occur. Currently Loctite 515. Part number 21826040.

POWERPART Jointing compound

Universal jointing compound which seals joints. Currently Hylomar. Part number 1861155 or 1861117.

POWERPART Lay-Up 1

A diesel fuel additive for protection against corrosion. Part number 1772204.

POWERPART Lay-Up 2

Protects the inside of the engine and of other closed systems. Part number 1762811.

POWERPART Lay-Up 3

Protects outside metal parts. Part number 1734115.

POWERPART Liquid gasket

To seal flat faces of components where no joint is used. Especially suitable for aluminium components. Currently Loctite 518. Part number 21820518

POWERPART Nutlock

To retain and seal threaded fasteners and cup plugs where easy removal is necessary. Currently Loctite 242e. Part number 21820242

POWERPART Platelock

Medium strength anaerobic threadlock for tight fitted metal surfaces. Suitable for metal plated surfaces and stainless steel.

Currently Loctite 243. Part number 21826039.

POWERPART Repel

Dries damp equipment and gives protection against corrosion. Passes through dirt and corrosion to lubricate and to assist removal of components. Currently Loctite repel. Part number 21825164.

POWERPART Retainer (high strength)

To retain components which have an interference fit. Currently Loctite 638. Part number 21820638.

POWERPART Retainer (oil tolerant)

To retain components which have a transition fit. Currently Loctite 603. Part number 21820603.

POWERPART Silicone adhesive

An RTV silicone adhesive for application where low pressure tests occur before the adhesive sets. Used for sealing flange where oil resistance is needed and movement of the joint occurs.

Currently Loctite 5900. Part number 21826038.

POWERPART Silicone rubber sealant

Silicone rubber sealant which prevents leakage through gaps.

Currently Hylosil. Part number 1861108.

POWERPART Studlock

To permanently retain large fasteners and studs. Currently Loctite 270. Part number 21820270.

Continued

POWERPART recommended consumable products Continued

POWERPART Threadlock

To retain small fasteners where easy removal is necessary.

Currently Loctite 222e. Part number 21820222.

POWERPART Threadlock (heavy duty)

To provide a heavy duty seal to components that have a light interference fit.

Currently Loctite 262. Part number 21820262.

POWERPART Threadlock (hydraulic/pneumatic)

To retain and seal pipe connections with fine threads. Especially suitable for hydraulic and pneumatic systems.

Currently Loctite 542. Part number 21820542

POWERPART Threadlock (pipe)

To retain and seal pipe connections with coarse threads. Pressure systems can be used immediately.

Currently Loctite 575. Part number 21820575.

11A

Specifications

Basic engine data

Note: This information is given as a guide for personnel engaged on engine overhauls. The dimensions which are shown are those which are mainly used in the factory. The information applies to all engines, unless an engine type code is shown.

Number of cylinders.....	6
Cylinder arrangement	In line
Cycle.....	Four stroke
Induction system.....	Turbocharged or Turbocharged/intercooled
Combustion system	Direct injection
Nominal bore:	
- WK and WL	109,2 mm (4.301 in)
- WM and WN	116,6 mm (4.590 in)
Stroke:	
- WK and WL	118,9 mm (4.681 in)
- WM and WN	135,9 mm (5.350 in)
Compression ratio	16.5:1
Cubic capacity:	
- WK and WL	7,64 litres (466.4 in ³)
- WM and WN	8,71 litres (531.0 in ³)
Firing order	1, 5, 3, 6, 2, 4
Valve tip clearances (cold):	
- Inlet and exhaust.....	0,64 mm (0.025 in)
Lubricating oil pressure (minimum):	
- Idle.....	137 kPa (20 lbf/in ²) 1,4 kgf/cm ²
- maximum engine speed and normal engine temperature	276 kPa (40 lbf/in ²) 2,8 kgf/cm ²
Capacity of a typical lubricating oil sump (1):	
- Without filter canister.....	22,7 litres (40.0 UK pints) 24 US quarts
- With filter canister.....	28,3 litres (49.9 UK pints) 28 US quarts
Typical coolant capacity (engine only).....	12,8 litres (22.5 UK pints) 13,5 US quarts
Direction of rotation	Clockwise from the front

(1) The capacity of the sump may vary according to the application. Fill to the "Full" mark on the dipstick. Do not exceed the "Full" mark.

11A

Recommended torque settings

Note:

- The torque tensions below apply to components lubricated lightly with clean engine oil before they are fitted.
- The setscrew for the upper idler gear is supplied with a sealant on its thread. Do not put lubricating oil on the thread of this setscrew.

Standard torques

Thread size	Flanged head fasteners				Non-flanged head fasteners			
	Nm	lbf ft	kgf m	Spanner size mm	Nm	lbf ft	kgf m	Spanner size mm
M6x1	11	8	0,11	8	8	6	0,08	10
M8x1,25	24	18	0,25	10	20	15	0,21	13
M10x1,5	49	36	0,50	13	40	30	0,41	16
M12x1,75	83	61	0,84	15	69	51	0,71	18
M16x2	208	154	2,13	21	173	128	1,77	24

Specific torques

Description	Nm	lbf ft	kgf m
Aspiration system			
Setscrew, breather pipe, bottom	49	36	5,0
Setscrew, breather pipe, top	83	61	8,4
Setscrews, turbocharger to exhaust manifold	66	49	6,8
Setscrews, turbocharger compressor housing to backplate	23	17	2,35
Setscrews, turbocharger turbine housing to bearing housing	13	9.6	1,3
Auxiliary equipment			
Nut, air compressor drive gear	149	110	15,21
Setscrews, air compressor mounting bracket to engine	115	85	11,9
Setscrews, air compressor to engine	62	46	6,4
Setscrews, air compressor to mounting bracket	66	49	6,7
Cooling system			
Setscrews, coolant filter flange to timing case	26	19	2,6
Setscrews, fan drive	22	16	2,2
Setscrews, fan drive pulley	7	5.5	0,8
Setscrews, fan belt tensioner to timing case	50	37	5,1
Setscrews, water pump pulley	7	5.5	0,8
Fasteners, water pump to timing case cover	7	5.5	0,8
Crankshaft assembly			
Setscrews, main bearings	157	160	15,9
Setscrews, main bearings (engine serial number 850000 or more)	176	130	18,0
Setscrews, pulley/ damper assembly	217	100	22,0
Setscrews, rear oil seal housing to cylinder block	24	18	2,5
Cylinder head assembly			
Setscrews, cylinder head	(see	chapter	12)
Setscrews, engine lift brackets	60	44	6,0
Setscrews, exhaust manifold to cylinder head	81	60	8,3
Setscrews, rocker cover	18	13	1,8
Setscrews, supply manifold to cylinder head	81	60	8,3
Flywheel and flywheel housing			
Setscrews, flywheel	136	100	13,8
Setscrews, flywheel housing	108	80	11,0
<i>Continued</i>			

11A

Description	Nm	lbf ft	kgf m
Fuel system			
Banjo bolt, fuel return pipe	35	26	3,6
Delivery valve assembly, to lift pump	42	31	4,3
End nut, lift pump	42	31	4,3
Locknut, for the adjustment screw of the return valve	27	20	2,8
Nuts, fuel lift pump to high-pressure pump	6	4	0,6
Return valve, to supply manifold	35	26	3,6
Setscrew, injector unit	14	10	1,4
Setscrews, filter head to cylinder block	18	13	1,8
Union nut, fuel return pipe	27	20	2,8
Lubrication system, low-pressure			
Setscrews, oil cooler to cylinder block	26	19	2,6
Setscrews, oil strainer and suction pipe	20	15	2,1
Setscrews, sump	23	17	2,4
Plug, sump	68	50	7,0
Valve, oil temperature/pressure control (fitted in the oil cooler)	34	25	3,5
Lubrication system, high-pressure			
Drain plug, supply manifold	81	60	8,3
End nut, to secure the solenoid to the regulator valve	6	4.5	0,6
Regulator valve for injection control pressure, to pump	35	26	3,6
Sensor for injection control pressure, to supply manifold	26	19	2,6
Setscrews, drive gear to pump	129	95	13,1
Setscrews, high-pressure pump to timing case	27	20	2,8
Union nut, high-pressure hose from pump to supply manifold	26	19	2,6
Pistons and connecting rod assemblies			
Setscrews, connecting rods	157	115	15,9
Timing case and drive assembly			
Setscrews, camshaft thrust plate	26	19	2,6
Setscrews, timing case backplate	26	19	2,6
Setscrews, timing case cover	22	16	2,2
Setscrews, timing plate to camshaft gear	7	5	0,7
Setscrew, lower idler gear	637	470	65,6
Setscrew, upper idler gear	332	245	33,9

12A

Cylinder head assembly

General description

All Peregrine EDi and the 1300 Series EDi engines have the inlet manifold contained in the rocker cover. The rocker cover also contains the engine breather assembly.

In a diesel engine there is little carbon deposit and for this reason the number of hours run is no indication of when to overhaul a cylinder head assembly. The factors that indicate when an overhaul is necessary are how easily the engine starts and its general performance.

The cylinder head assembly has two valves fitted for each cylinder, each fitted with a single valve spring, a valve seal assembly and a valve rotator.

Valve seat inserts and valve guides are fitted in the cylinder head for the inlet valves and the exhaust valves. The valve seat inserts and the valve guides can be renewed.

The face angle of the inlet valve seats is 30°, and is 45° on the exhaust valves seats. The face angle of the valves is 31° on the inlet valves, and is 46° on the exhaust valves.

Sleeves are fitted in the cylinder head to house and to seal the fuel injector units.

12A

Rocker cover

To remove and to fit

12A-1

Consumable products:

POWERPART Silicon rubber sealant

To remove

- 1 Remove the pipe for the air inlet from the rocker cover.
- 2 Remove the setscrews which retain the engine breather pipe, and remove the pipe.
- 3 Disconnect the wiring loom (A1) for the fuel injector units, at the rocker cover connector (A2).
- 4 Press the four tags that secure the electrical connector (B1) for the wiring loom to the rocker cover, and push the connector into the rocker cover.
- 5 Remove the 13 setscrews (C) which retain the rocker cover.
- 6 Lift carefully the rocker cover and tilt it away from the exhaust manifold. Ensure that the electrical connector for the wiring loom is free from the rocker cover then remove the rocker cover from the engine.
- 7 Remove the rocker cover gasket from the cylinder head.

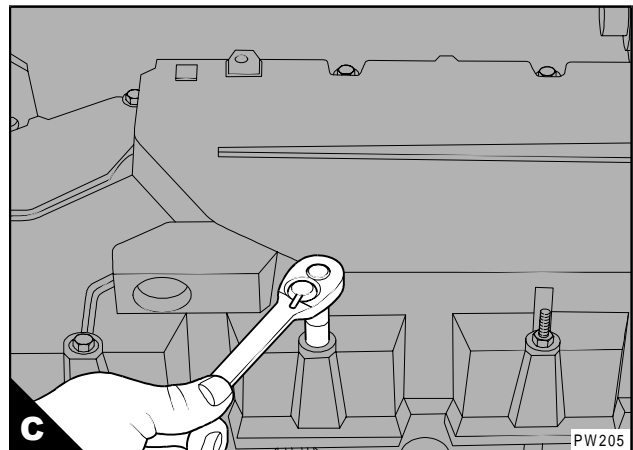
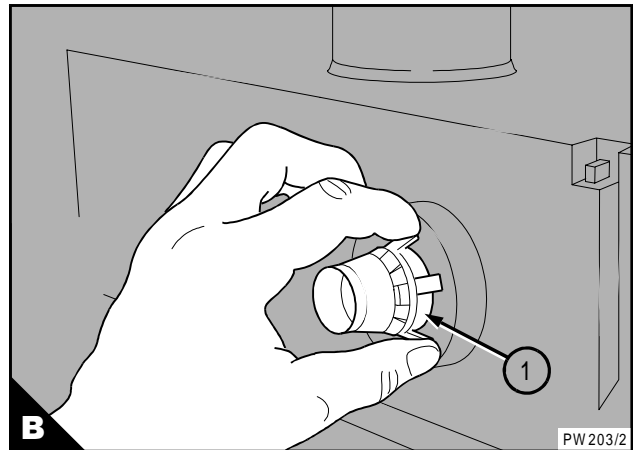
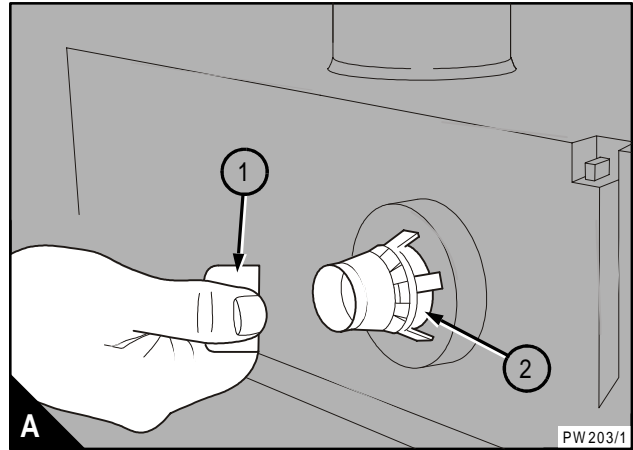

To fit

- 1 Clean the cylinder head and the rocker cover.
- 2 Renew the elements of the engine breather, if necessary, [see operation 12A-2](#).
- 3 Renew the gasket for the rocker cover, if necessary.
- 4 Hold the rocker cover over the engine and push electrical connector (B1) for the wiring loom of the fuel injector units into its hole in the rocker cover. Ensure that the four tags engage on the rocker cover (B).
- 5 Fit the rocker cover, fit and tighten the 13 setscrews (C) to 18 Nm (13 lbf ft) 1,8 kgf m.
- 6 Connect the wiring loom (A1) for the fuel injector units, at the rocker cover connector (A2).
- 7 Fit a new "O" ring onto the breather tube.
- 8 Apply clean lubricating oil to the "O" ring.
- 9 Fit the breather pipe into the cover.
- 10 Fit and tighten the top and bottom setscrews of the breather tube.

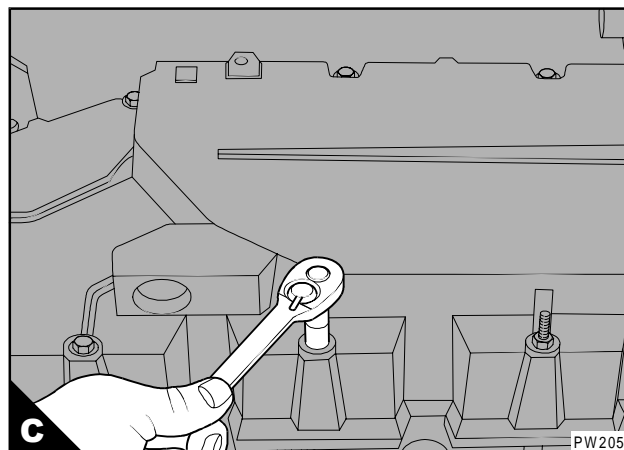
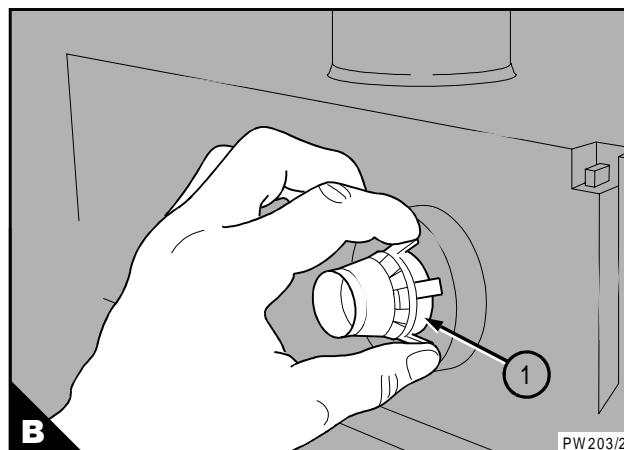
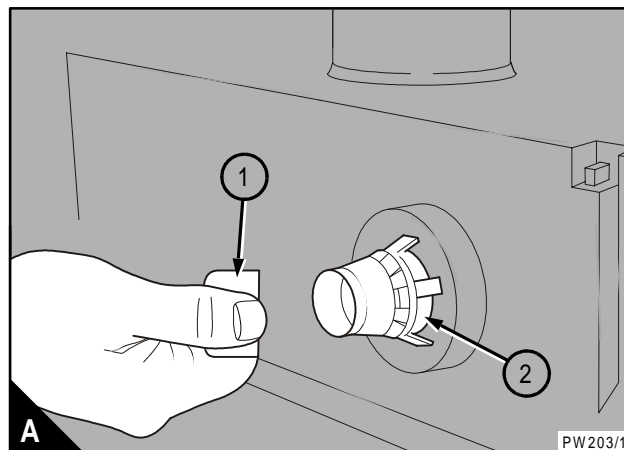

12A

Engine breather elements

To renew

12A-2

- 1 Remove the rocker cover, [see operation 12A-1](#).
- 2 Remove and discard the breather elements (A1) from their recesses (A2) in the rocker cover (A3).
- 3 Clean the rocker cover. Ensure that the recesses are clean.
- 4 Fit a new breather element into each recess.
- 5 Fit the rocker cover, [see operation 12A-1](#).

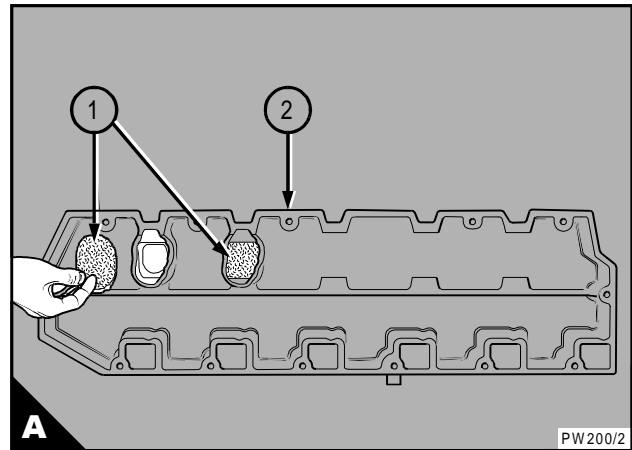

Rocker assembly

To remove and to fit

12A-3

Warning! Do not drain the coolant while the engine is still hot and the system is under pressure because dangerous hot coolant can be discharged.

To remove

- 1 Remove the rocker cover, see operation 12A-1.
- 2 Remove the drain plug (A1) from the side of the cylinder block (behind the high-pressure pump), and the drain plug (B1) from the lubricating oil cooler in order to drain the engine. Open the tap or remove the drain plug at the bottom of the radiator in order to drain the radiator. If the radiator does not have a tap or drain plug, disconnect the hose at the bottom of the radiator.
- 3 Loosen the adjustment screws on the rocker levers one turn (C).
- 4 Release the rocker shaft setscrews evenly and gradually in the sequence 1-3-5-2-4-6 from the front of the engine, to avoid damage to the rocker assembly.
- 5 Remove the rocker assembly, complete with its setscrews and their washers (D).

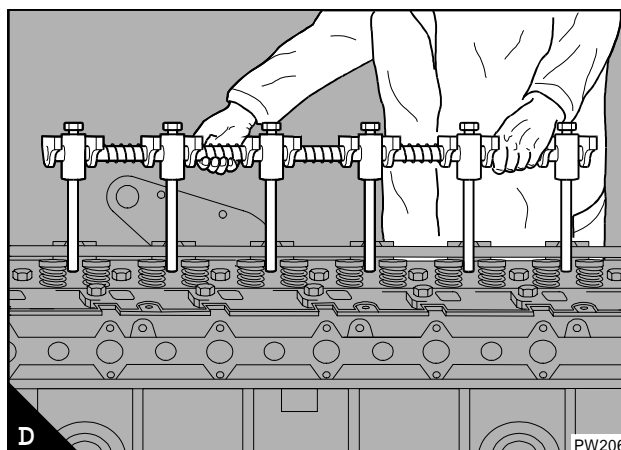
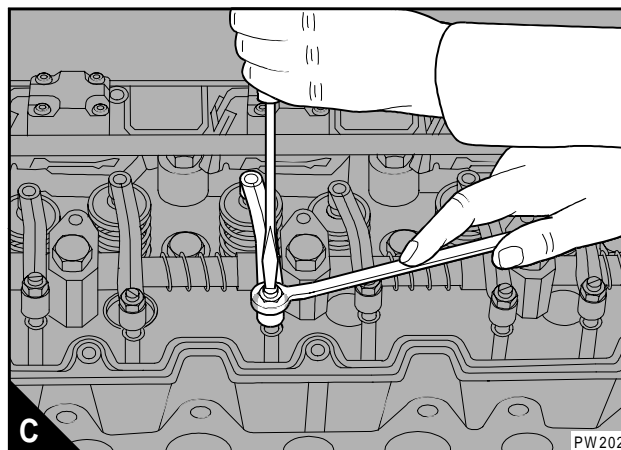
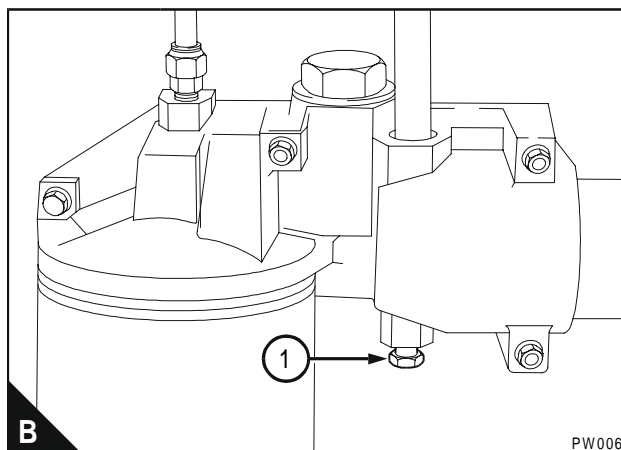
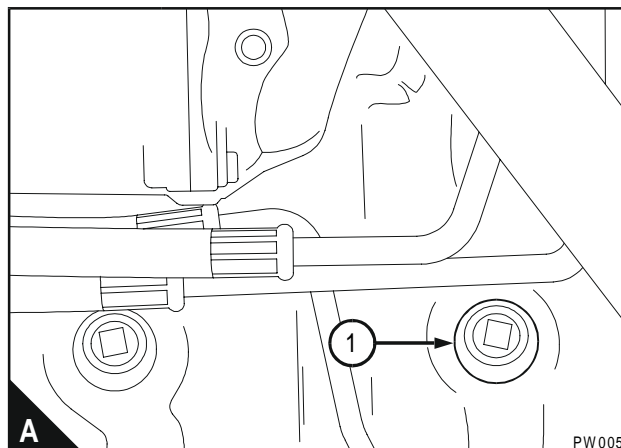

12A

To fit

1 Put the push rods and the rocker shaft assembly in position. Check that the push rods fit correctly in the sockets of the tappets. Check that the ends of the adjustment screws fit correctly in the sockets of the push rods.

2 Inspect the cylinder head setscrews for damage and excessive wear. Renew any setscrews that are damaged or excessively worn.

3 Lightly lubricate the threads and the thrust faces of the cylinder head setscrews with clean engine lubrication oil.

Warning! *Ensure that there is no lubricating oil in the holes for the cylinder head setscrews. If there is oil in these holes, the cylinder block could be damaged by hydraulic pressure when the setscrews are tightened.*

4 Engage all the setscrews in their correct positions, except the setscrews at each end of the shaft, and tighten them finger tight.

5 Ensure that the rocker shaft is in the correct position when the setscrews are tightened. To do this:

- Put a 0,13 mm (0.005 in) feeler gauge (A2) between the rocker lever (A3) for the inlet valve of number one cylinder and the first mounting bracket (A1) of the rocker shaft.
- Put another 0,13 mm (0.005 in) feeler gauge between the rocker lever for the exhaust valve of number six cylinder and the last bracket of the rocker shaft
- Fit the end setscrews, and tighten them finger tight.

6 Tighten the setscrews in the correct sequence and to the correct torque, [see operation 12A-6](#).

7 Fill the cooling system.

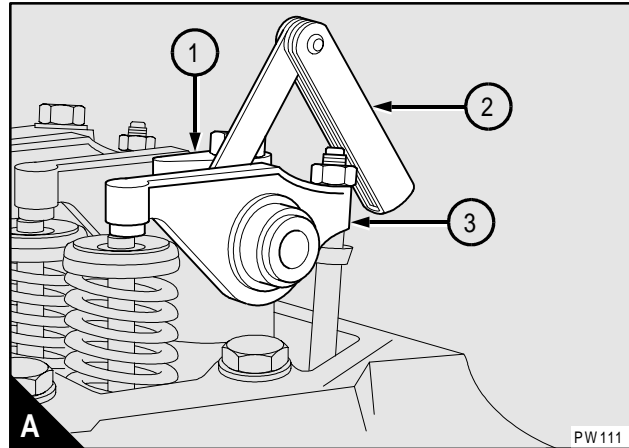

To dismantle and inspect

12A-4

- 1 Remove the circlip from the end of the rocker shaft.
- 2 Slide all of the components from the shaft and put them on a bench in the correct sequence.
- 3 Inspect all of the components for signs of damage.
- 4 Check the rocker shaft, the rockers and the bushes for deep scratches or signs of excessive wear.
- 5 The bushes of the rocker lever have a groove to assist with lubrication, ensure that the grooves are free from debris.
- 6 Measure the internal diameter of the bushes at two places 90° apart and record the readings.
- 7 Measure the external diameter of the rocker shaft at two places 90° apart where it contacts the bushes of the rocker levers. Record the readings.
- 8 If the difference between the measurements is greater than 0,13mm (0.005 in), renew the worn component, either the shaft or the bushes.
- 9 Ensure that all the lubricating oil holes and passages of the rocker shaft assembly are free of debris.
- 10 Check the plugs at the ends of the rocker shaft for leaks or damage.
- 11 Measure and record the free length of the rocker shaft springs.
- 12 Measure and record the length of the springs when a load of 31N (7 lbf) 3,2 kgf is applied. Compare both measurements with the measurements given in data and dimensions.
- 13 Renew any springs that are not within the tolerance.

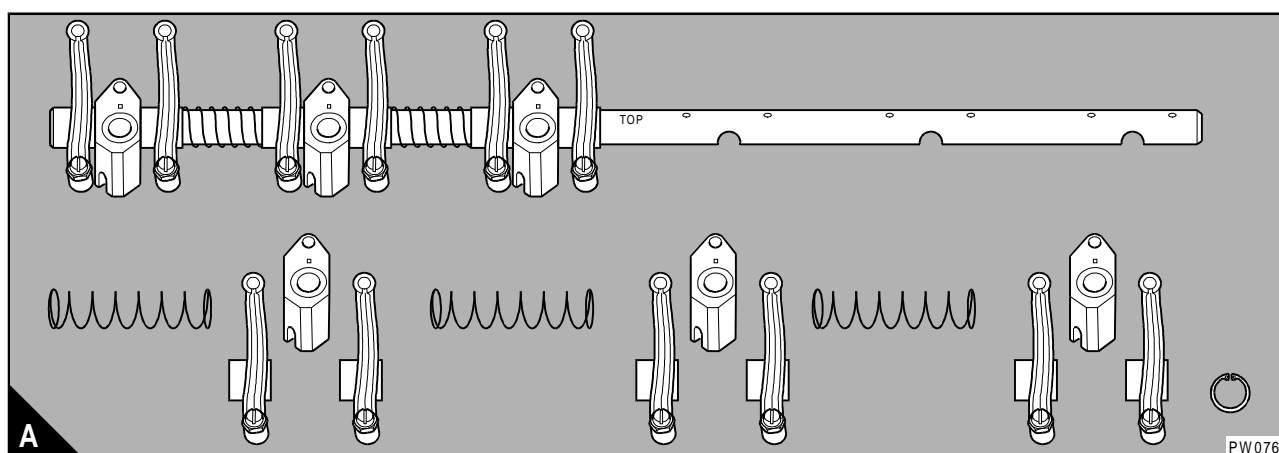

12A

To assemble

12A-5

- 1 Apply clean lubricating oil to the bushes of the rocker levers.
- 2 Ensure that a circlip is fitted to one end of the rocker shaft.
- 3 The rocker shaft is marked "TOP" at the centre of its length. Ensure that this mark is at the top. Slide the components onto the rocker shaft in the correct sequence, ensure that the lubricating oil holes are aligned correctly.
- 4 Ensure that the setscrew holes in the rocker shaft brackets align with the recesses in the shaft.
- 5 Compress the rocker shaft springs and fit the second circlip to the rocker shaft.

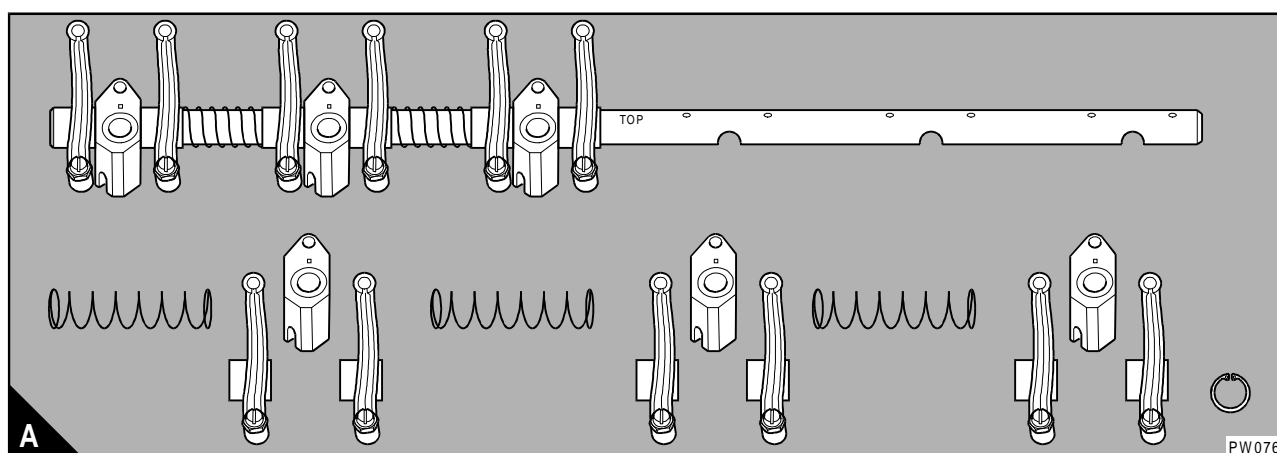

Cylinder head

To remove and to fit

12A-6

To remove

Warning! *The cylinder head weighs 77 kg (170 lbs). Use lift equipment or obtain assistance to lift the cylinder head.*

- 1 Drain the cooling system.
- 2 Disconnect the high-pressure oil pipe (A1) at the supply manifold (A3).
- 3 Disconnect the fuel pipe (A2) at the supply manifold (A3).
- 4 Remove the rocker cover, [see operation 12A-1](#).
- 5 Remove the rocker shaft assembly, [see operation 12A-3](#).
- 6 Remove all the push rods and record their relative positions.
- 7 Remove all the pipes and hoses from the turbocharger.
- 8 Remove the exhaust manifold setscrews and remove the exhaust manifold and turbocharger as an assembly. Remove the gasket for the exhaust manifold.
- 9 Release evenly and gradually then remove the cylinder head setscrews together with their washers.
- 10 Carefully separate the cylinder head from the cylinder block with a suitable lever (B).
- 11 Remove the cylinder head.

Caution: *Put the cylinder head on blocks of wood to protect the tips of the fuel injector units.*

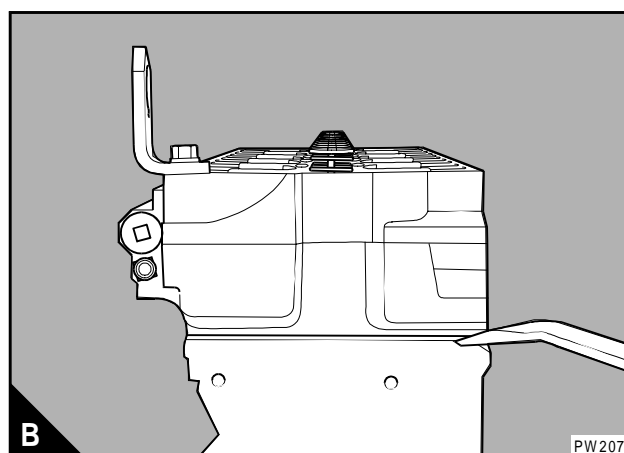
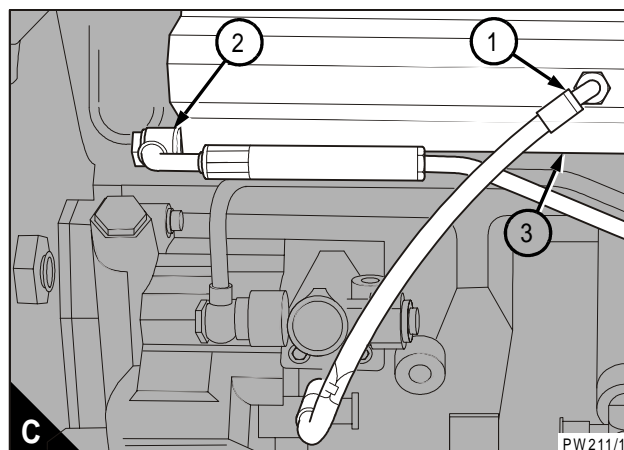

12A

To fit

Warning! *The cylinder head weighs 77 kg (170 lbs). Use lift equipment or obtain assistance to lift the cylinder head.*

- 1 Clean the bottom face of the cylinder head and the top face of the cylinder block. Ensure that there is no debris in the cylinder bores. Ensure that the holes for the cylinder head setscrews are dry and free from debris.
- 2 Fit the thermostat, if it was removed earlier.
- 3 Check the cylinder liner protrusion, [see operation 16A-3](#).
- 4 Fit the dowels into the cylinder block (A).
- 5 Fit a new cylinder head gasket onto the dowels (A).
- 6 Put the cylinder head in position (A)
- 7 Fit the rocker shaft assembly, [see operation 12A-3](#).

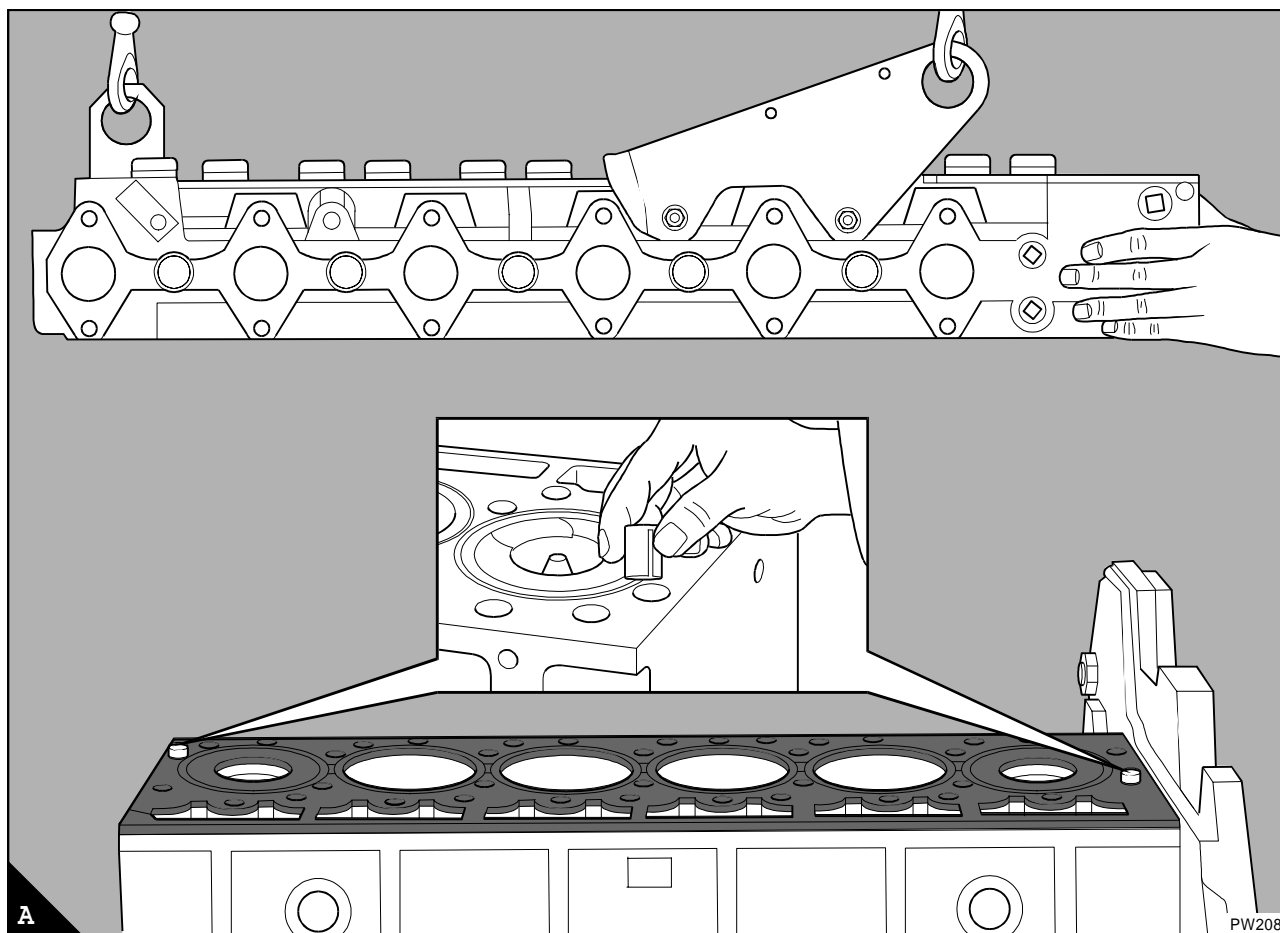

8 Tighten evenly and gradually all of the cylinder head setscrews as follows:

- 150 Nm (110 lbf ft) 15,0 kgf m in the sequence shown in (A).
- 210 Nm (155 lbf ft) 21,5 kgf m in the sequence shown in (A).
- 225 Nm (165 lbf ft) 23,0 kgf m in the sequence shown in (B).

9 Remove both of the feeler gauges.

10 Check the rocker levers for free movement.

11 Set the valve tip clearance, [see operation 12A-16](#).

12 Fit the high-pressure oil pipe at the supply manifold.

13 Fit the fuel pipe at the supply manifold.

14 Fit the rocker cover, [see operation 12A-1](#).

15 Fit the gasket for the exhaust manifold. Fit the exhaust manifold and turbocharger assembly. Fit and tighten the setscrews for the exhaust manifold to 81 Nm (60 lbf ft) 8,3 kgf m.

16 Fit all of the pipes and hoses removed earlier from the turbocharger.

17 Fill the cooling system.

18 Eliminate air from the fuel system, [see operation 20A-7](#).

19 Fill the cooling system.

20 Eliminate air from the fuel system, [see operation 20A-7](#).

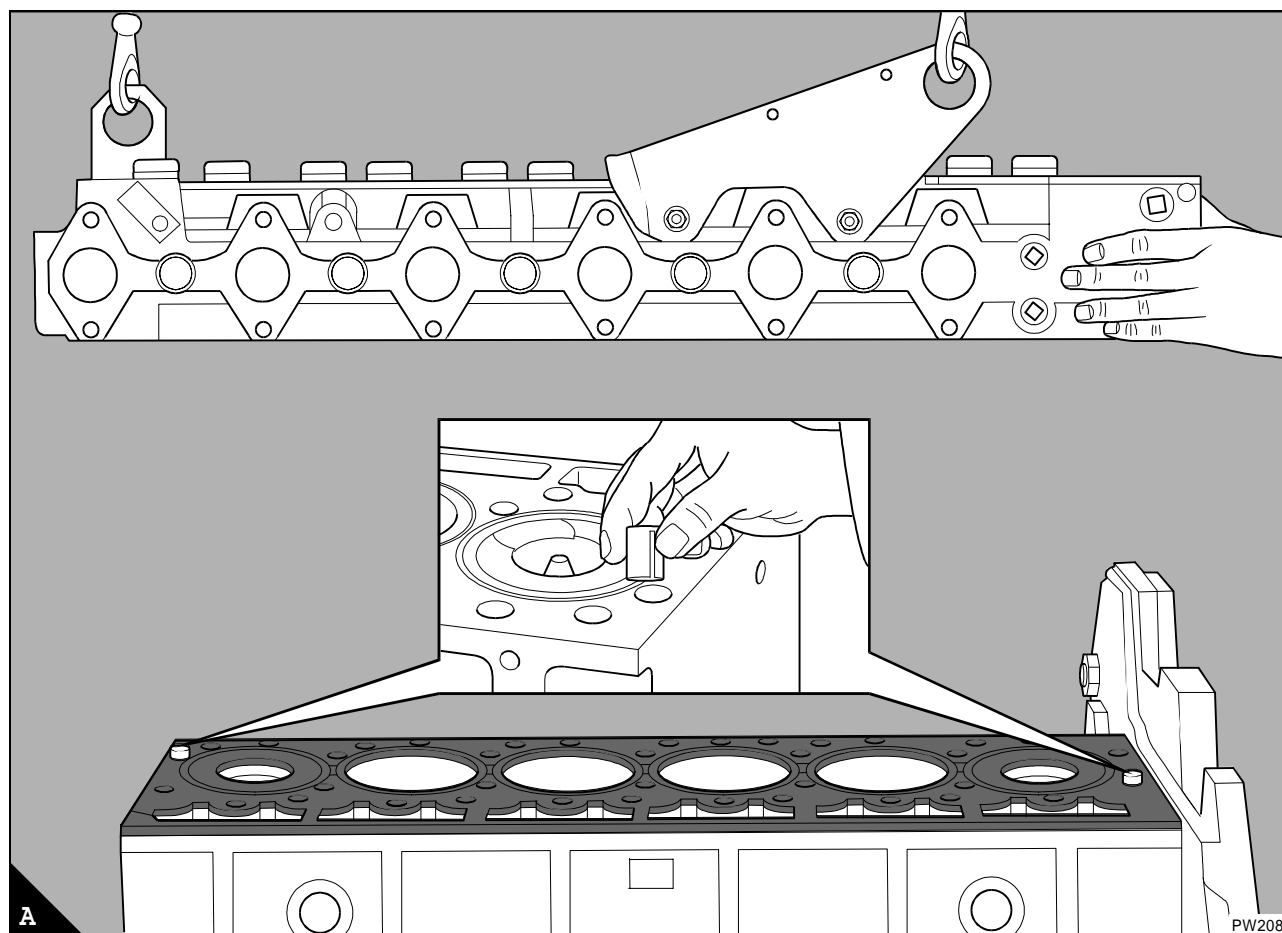

12A

Valves and valve springs

To remove and to fit

12A-7

To remove

Warning! *Protect your eyes when a valve spring is compressed.*

- 1 Remove the cylinder head, [see operation 12A-5](#). Put the cylinder head on a surface that will not damage its face.
- 2 Use a valve spring compressor to compress the valve spring.
- 3 Remove the collets (A1).
- 4 Release and remove the valve spring compressor.
- 5 Remove the valve rotator (A2), the valve rotator seal (A3), the valve spring (A4), the valve seal assembly (A5) and the valve (A6).
- 6 Separate the inlet valve springs from the exhaust valve springs. They are rated differently.
- 7 Discard the valve seal assemblies.

To fit

Warning! *Protect your eyes when a valve spring is compressed.*

- 1 Ensure that the valve guides are clean.
 - 2 Apply clean lubricating oil to the valve stems and fit the valves (A6) into the valve guides.
 - 3 Apply clean lubricating oil to the inside of new valve seal assemblies (A5) and fit them to the valve stems. Ensure that each valve seal assembly is fitted fully into the valve spring recess in the cylinder head.
 - 4 Put the valve springs (A4) in position on the valve seal assemblies.
- Caution:** *Ensure that the inlet valve springs are fitted to inlet valves and that the exhaust valve springs are fitted to exhaust valves. They are rated differently.*
- 5 Fit new seals (A3) to the valve rotators (A2) and put the rotators onto the valve springs.
 - 6 Use a valve spring compressor to compress each valve springs.
 - 7 Fit the collets (A1).
 - 8 Release and remove the valve spring compressor.

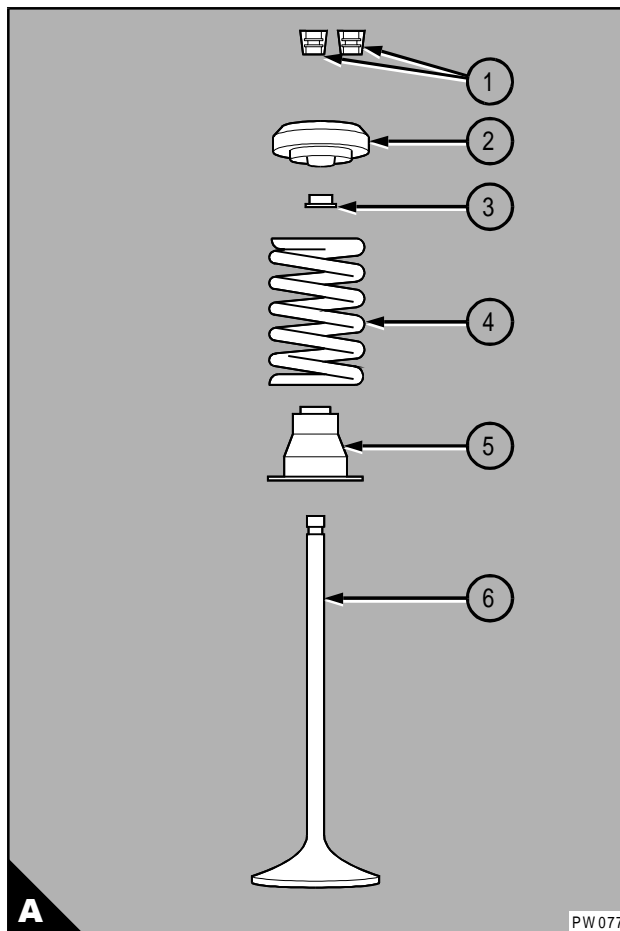

To inspect and to correct

12A-8

Special tools:

Valve depth gauge 21825617 and 21825496.

- 1 Remove the cylinder head, [see operation 12A-5](#).
 - 2 Put a small amount of low viscosity oil, for example calibration fluid, into the inlet and exhaust ports then check for leakage.
 - 3 Wait five minutes, then check again for leakage.
- Note:** If no oil leaks past the valve seat, it does not need to be reground.

4 Ensure that the heads of the valves and the face of the cylinder head are clean.

5 Check the depth of the valves below the face of the cylinder head before the valve springs are removed. Put the valve depth gauge on the face of the cylinder head and set the dial gauge to zero. Carefully put the valve depth gauge in position over the head of each valve (A) and compare the measurement with data and dimensions at the end of this section.

6 If a valve is below the depth limit, check the valve depth with a new valve in position.

7 If the valve depth is still below the limit, the valve seat insert must be renewed, [see operation 12A-14](#).

8 Remove the valves and valve springs, [see operation 12A-6](#).

9 Visually inspect the condition of the collets.

10 Visually inspect the valve springs for corrosion, for damage or distortion.

11 Check that the end faces of the springs are square and flat.

12 Measure the free length of the valve springs (B) and compare it with the data and dimensions.

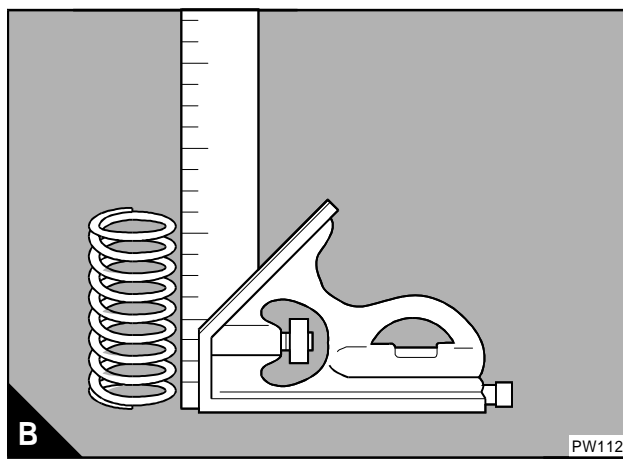
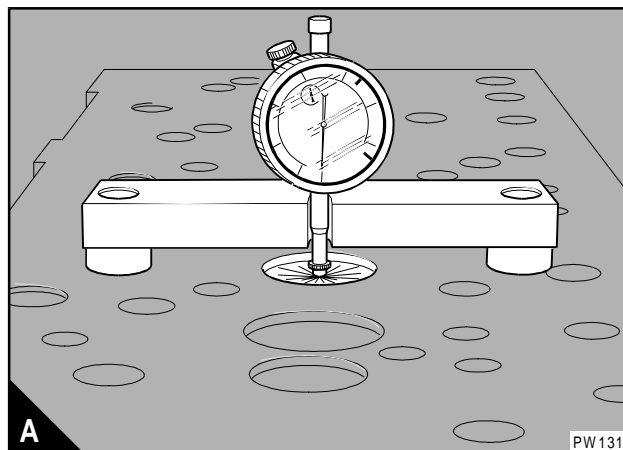

Continued

12A

13 Measure the springs under a load (A), see data and dimensions.

14 Check the valves for cracks. Check the stems for wear and correct fit in their valve guides.

15 Check that the seat faces of the valves are not badly burnt or damaged. Seat faces of valves which are damaged can be ground on a special machine. Valves which have only a little damage can be lapped to their valve seats. When new valves are fitted, the valve depths must be checked.

16 Measure the valve dimensions and compare them with data and dimensions.

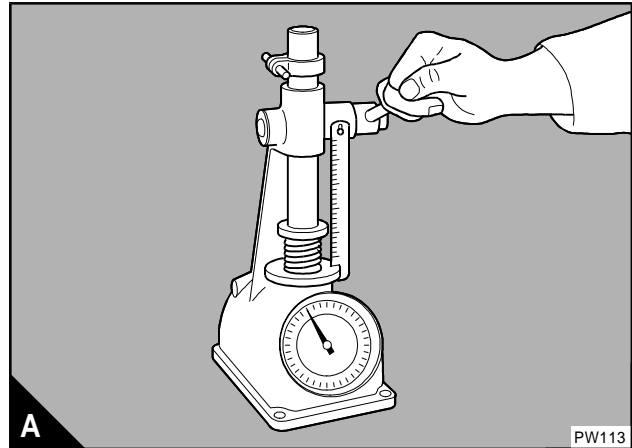

To inspect a valve rotator

12A-9

1 Visually inspect the valve rotator for corrosion, damage or distortion.

2 To test the operation of the rotator (B4), put a valve spring (B3), the valve rotator and a steel ball bearing (B5) in a valve spring tester (B1).

3 Mark the rotator with a reference line (B2).

4 Compress the valve spring rapidly several times and check that the rotator rotates.

5 Replace any rotator that does not rotate.

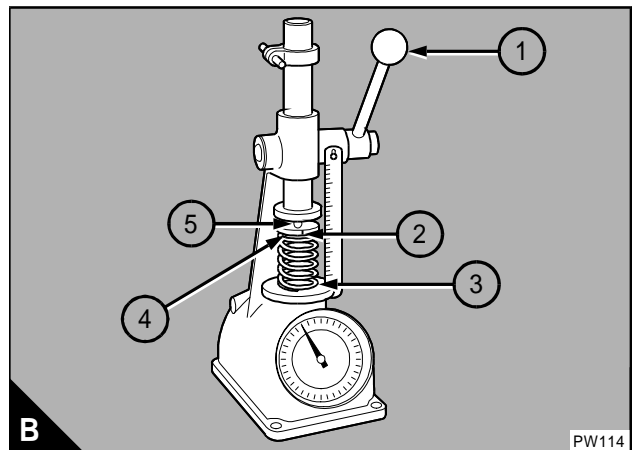

Valve guides

To inspect a valve guide

12A-10

Check the valve guides for wear. The maximum clearance between the valve stem and the bore of the guide is 0,15 mm (0.006 in) for the inlet valves and the exhaust valves. If the clearance with new valves fitted is more than the limit, then a new valve guide must be fitted.

To remove and to fit

12A-11

Special tools:

Remover/replacer for valve guides, 21825478

Adaptor 21825479

Adaptor 21825935

To remove

1 Fit the adaptor 21825479 (A4) into the remover/replacer tool 21825478 (A3). Pass the tool and adapter through the spacer (A5) and the cylinder head, from the bottom face. Fully fit the attachment (A7) to secure the adapter in the valve guide (A6).

2 Turn the top handle (A1) to take up the excess movement in the tool and turn the bottom handle (A2) to pull the valve guide out of the cylinder head.

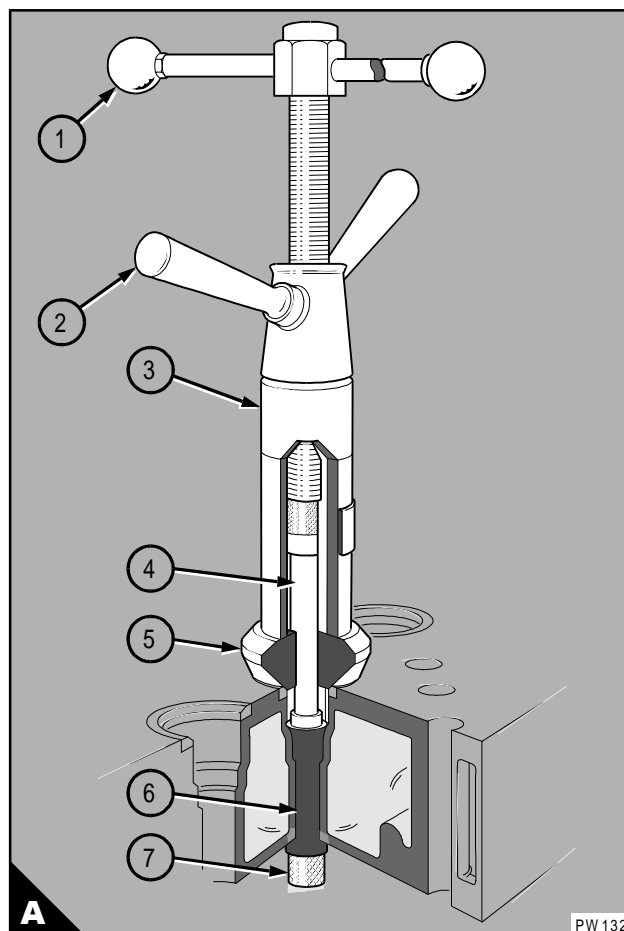

12A

To fit

- 1 Clean the parent bore for the valve guide (A4).
- 2 Lubricate the outer surface of the new guide with clean engine lubricating oil.
- 3 Fit the adaptor 21825479 (A5) into the remover/replacer tool 21825478 (A3). Pass the tool and adapter through the spacer (A4) and the cylinder head, from the bottom face. Fully fasten the valve guide, with the large 15° chamfer at the bottom, and the distance piece (A7), 21825935, onto the adapter with the attachment (A8).
- 4 Turn the top handle (A1) to take up the excess movement in the tool and turn the bottom handle (A2) to pull the valve guide into the cylinder head.

Caution: Do not ream new valve guides. They are supplied in a finished condition.

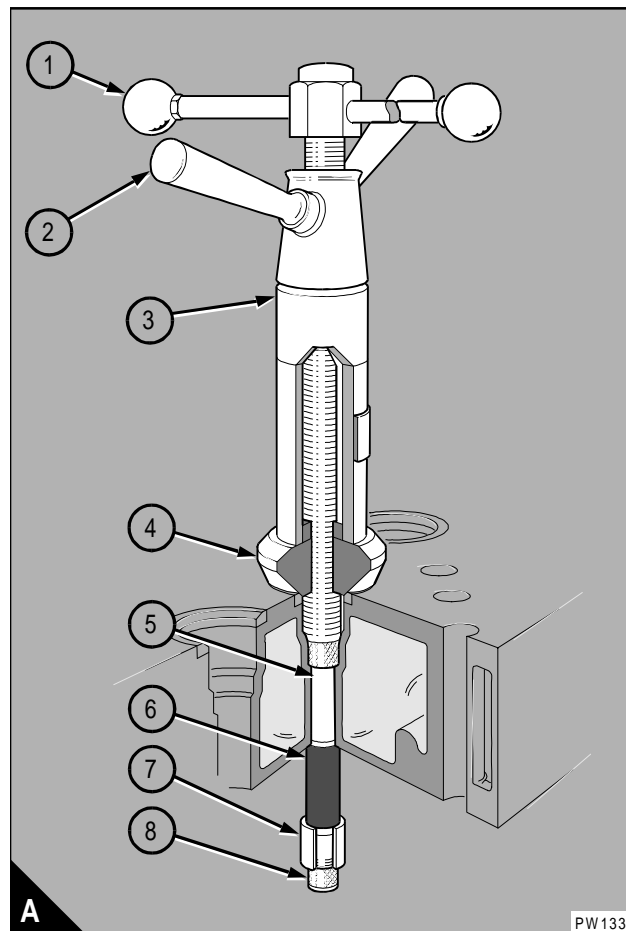

Cylinder head

To inspect and to correct

12A-12

- 1 Remove the cylinder head assembly, see operation 12A-6.
- 2 Remove the valve springs and the valves, see operation 12A-7.
- 3 Remove the thermostat, see operation 21A-2.
- 4 Inspect the cylinder head for signs of gas or coolant leakage.
- 5 Clean the face of the cylinder head, the passages for coolant and the passages for the lubricating oil.
- 6 The water jacket can be cleaned with a special solvent which must be used in accordance with the manufacturer's instructions.
- 7 Pressure test the cylinder head to a pressure of 124/138 kPa (18/20 lbf in²) 1,27/1,41 kgf cm² and inspect the cylinder head for leaks.

Warning! Always use a safety cage to protect the operator when a component is to be pressure tested in a bath of water. Fit safety wires to secure the plugs which seal the hose connections of a component which is to be pressure tested.

8 When the cylinder head is thoroughly clean, check it for cracks. Examine carefully the areas around the valve seats and around the holes for the injector units.

9 The bottom face of the cylinder head can be machined if:

- there is distortion, see paragraph 10
- there are deep scratches.

10 Use a straight edge and feeler gauges to check the cylinder head for distortion (A) across and along its bottom face, see data and dimensions. If the distortion is more than the limit given in data and dimensions, the bottom face can be machined.

Cautions:

- Remove only the minimum material and ensure that the thickness of the cylinder head will not be less than 106,17 mm (4.180 in) after the cylinder head has been machined.
- After the cylinder head has been machined the valve seats must be corrected to give the correct valve head depth, see operation 12A-13. It is advisable to work to the minimum limit to allow for later wear.

11 Check the valve seats for wear and for damage.

12 Before any work is done on the valve seats, new valve guides must be fitted, see operation 12A-11.

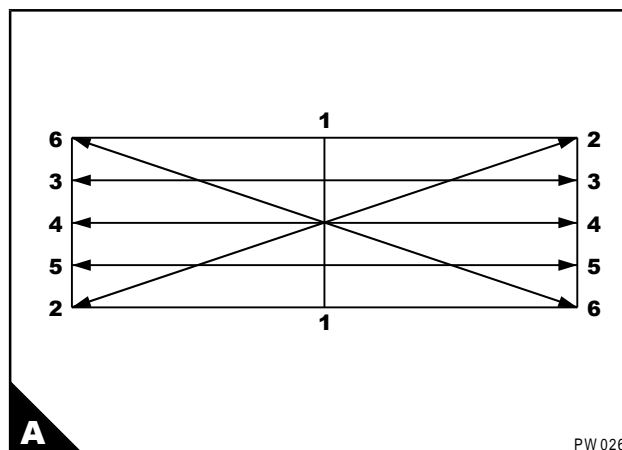

PW 026

12A

13 Where there is little damage, the valve and valve seat can be lapped. When the valve seats are lapped keep the seat to the measurements shown in data and dimensions. Ensure that all the compound used to lap the valve seat is removed from the valve and the valve seat.

14 Badly damaged valve seats can be corrected with a valve seat cutter, [see operation 12A-13](#).

To correct a valve seat with a valve seat cutter

12A-13

Special tools:

Cutter for 46° inlet valve seats, MS.281*

Cutter for 31° inlet valve seats, MS.642

Cutter for exhaust valve seats, MS.275*

Pilot for use with valve seat cutters, MS.150-9.5*

Handle set for use with valve seat cutters, MS.67B*

* Included in set of adjustable cutters for valve seats, MS.73A

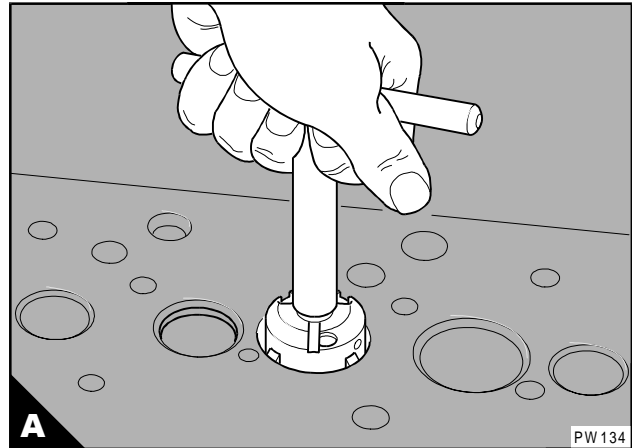

-
- 1** Before work is done on the valve seats, new valve guides must be fitted.
 - 2** Fit the pilot in the valve guide and tighten the pilot.
 - 3** Select the relevant cutter. Set the blades of the cutters to the diameter of the valve seat to be cut. Fit the cutter on the pilot and fit the handle. Ensure that the cutter is not allowed to fall on to the seat as this can damage the blades.
 - 4** Carefully rotate the cutter in a clockwise direction (A). Remove only the minimum material to ensure a good seat. Keep the seat as narrow as possible.
 - 5** When the seat is cut, remove the cutter and the pilot. Remove any debris from the area of the valve seat and the port.
 - 6** Fit the valve and lightly lap the valve and the seat.
 - 7** Check that the valve depth is within limits, [see operation 12A-8](#).
 - 8** If a valve seat has become too damaged or too worn to correct, a new valve seat insert can be fitted, [see operation 12A-14](#).

To fit valve seat inserts

12A-14

- 1 Fit new valve guides, [see operation 12A-11](#).
- 2 With the bore of the new valve guide used as a pilot, machine out the old insert. Remove all debris and clean the insert recess.
- 3 If the bottom face of the cylinder head has been machined, the insert will have to be surface ground on the back face to ensure that there is no protrusion of the insert above the bottom face of the cylinder head. After the back of the insert has been ground, ensure that the outer edge of the back face has a 0,9/1,3 mm (0.035/0.051 in) chamfer at 30° to the vertical.
- 4 Put the valve seat inserts in a deep freeze unit for 30 minutes. This will reduce the size of the valve seat inserts to allow them to fit more easily into their recesses.
- 5 With the bore of the valve guide used as a pilot, and with the rear face of the insert towards the cylinder head, press in the insert (A). Use a hydraulic press or a hand press in one continuous movement. Do not use a hammer on the insert and do not use lubrication. Ensure that the bottom of the insert is in contact with the bottom of the recess.
- 6 Cut the valve seat at an included angle of 90° for 45° valve seats or 120° for 30° valve seats, [see operation 12A-13](#). Lap the valve on to the valve seat. Ensure that the depth of the valve head below the face of the cylinder head is within the production limits, [see operation 12A-8](#). Work as near as possible to the minimum figure to allow for future wear on the valve seat.

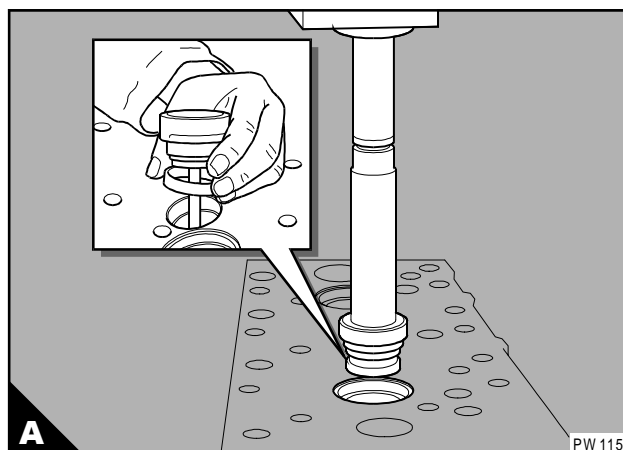

12A

To renew injector unit sleeves

12A-15

Special tools:

Special tap 27610091

Injector unit sleeve remover 21825960

Adapter 27610092

Adapter 27610093, for use with 21825960 and 27610092

Tool to fit the injector unit sleeve 27610094

To remove

1 Remove the fuel injector units, see operation 20A-2.

Caution: *If the correct procedure is not used, the cylinders of the engine will be filled with fuel and engine lubricating oil.*

2 Put a suitable plug into the bottom of each sleeve to prevent debris from entering the cylinder.

3 Put the special tap, 27610091, (A1) into the sleeve for the injector unit and cut a thread into the sleeve (A). Remove the tap.

4 Fit and tighten the adapter 27610092 (B1) into the injector unit sleeve, then fit the adaptor 27610093 into the adaptor 27610092.

5 Fit the injector unit sleeve remover 21825960 to the adaptor 27610093.

6 Remove the injector unit sleeve from the cylinder head (B).

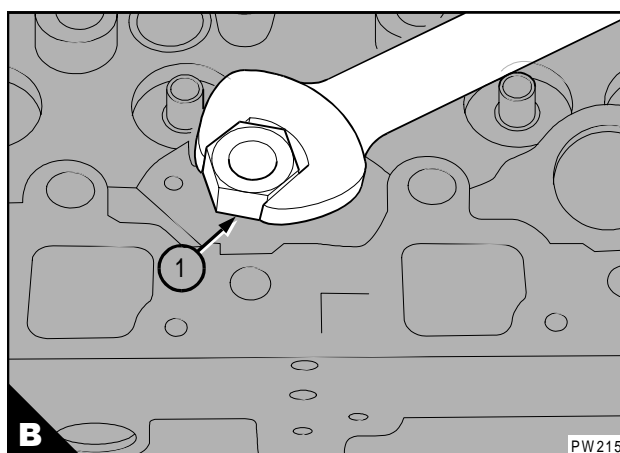
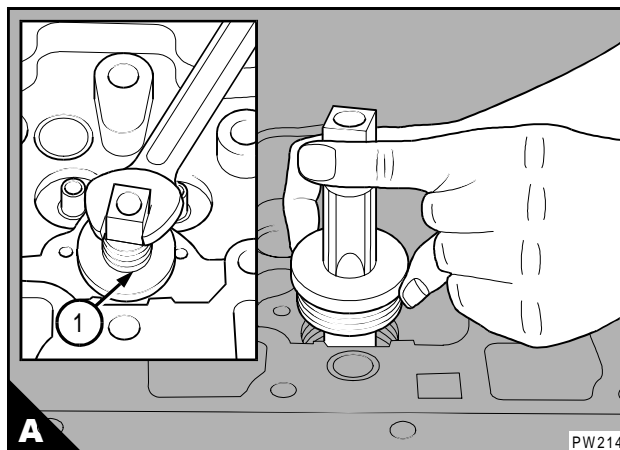

To fit

Caution: *Ensure that the piston is at the bottom of the cylinder or the tool used to fit the injector unit sleeve might hit the piston. Do not allow debris to fall into the cylinder.*

- 1 Use a wire brush to clean the top and bottom of the bore for the injector unit sleeve.
- 2 Remove any debris.
- 3 Put Loctite 262 on the top and bottom contact faces (A) of the injector unit sleeve.
- 4 Put the sleeve onto the tool 27610094. Put the sleeve and the tool into the bore for the injector unit in the cylinder head.
- 5 Hit the tool with a hammer to drive the injector unit sleeve into position at the bottom of the bore.
- 6 Remove the tool.
- 7 Fit the injector units, [see operation 20A-2](#).

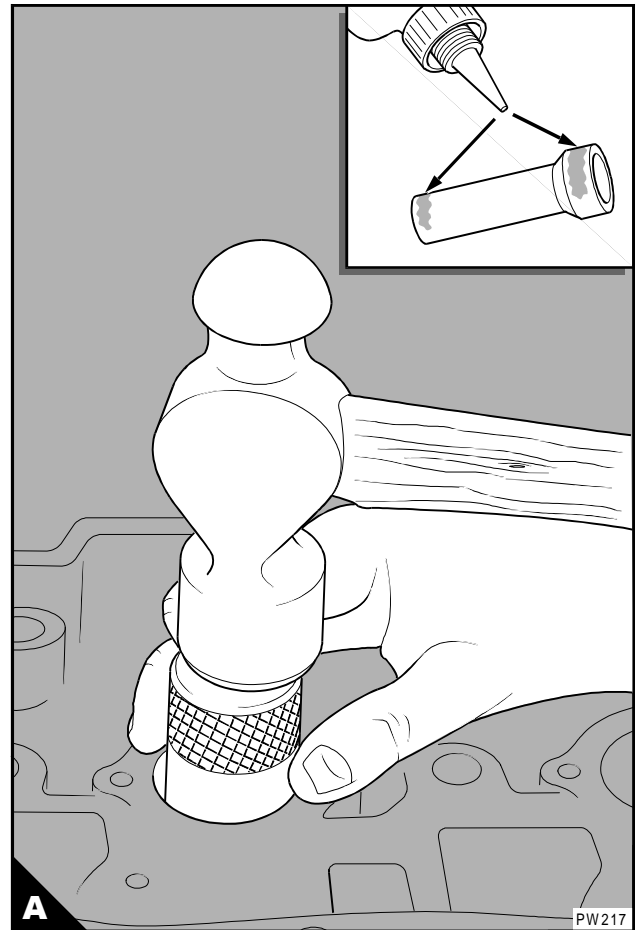

12A

To set the valve tip clearance

12A-16

Note:

- The valve tip clearance is measured between the top of the valve stem and the rocker lever (A).
- With the engine hot or cold, the correct clearances are 0,64 mm (0.025 in) for the inlet valves and for the exhaust valves.
- The sequence and positions of the valves are shown at (B). Number 1 cylinder is at the front of the engine.
- The arrangement of the valves for each cylinder, in sequence, is inlet valve then exhaust valve.

Method one

- 1 Remove the rocker cover, [see operation 12A-1](#).
- 2 Rotate the crankshaft in the normal direction of rotation until valve 11 (A) has just opened and valve 12 has not closed fully. Check/adjust the clearances of valves 1 and 2.
- 3 Set valves 3 and 4 as indicated above then check/adjust the clearances of valves 9 and 10.
- 4 Set valves 7 and 8 then check/adjust the clearances of valves 5 and 6.
- 5 Set valves 1 and 2 then check/adjust the clearances of valves 11 and 12.
- 6 Set valves 9 and 10 then check/adjust the clearances of valves 3 and 4.
- 7 Set valves 5 and 6 then check/adjust the clearances of valves 7 and 8.
- 8 Fit the rocker cover, [see operation 12A-1](#).

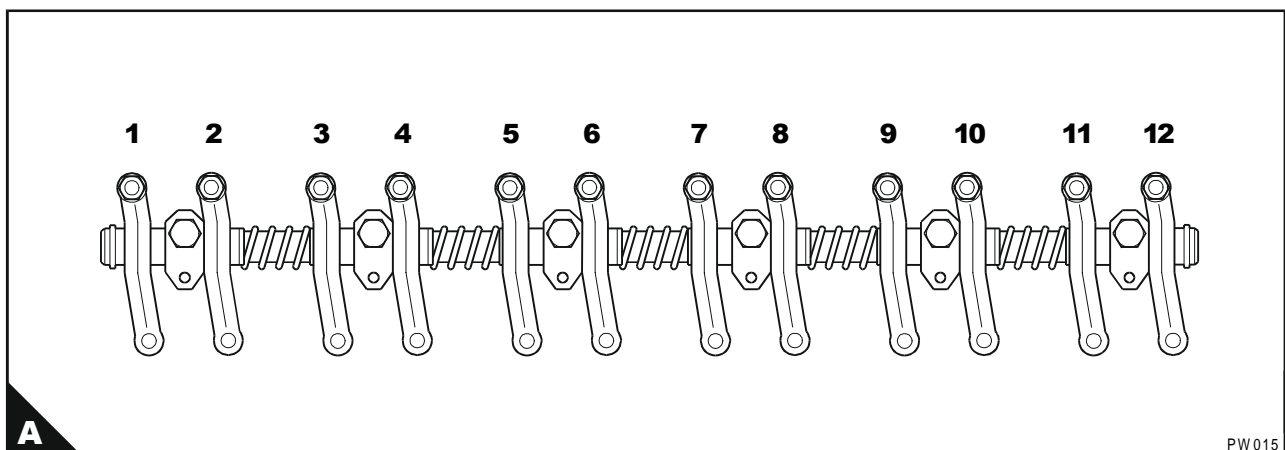
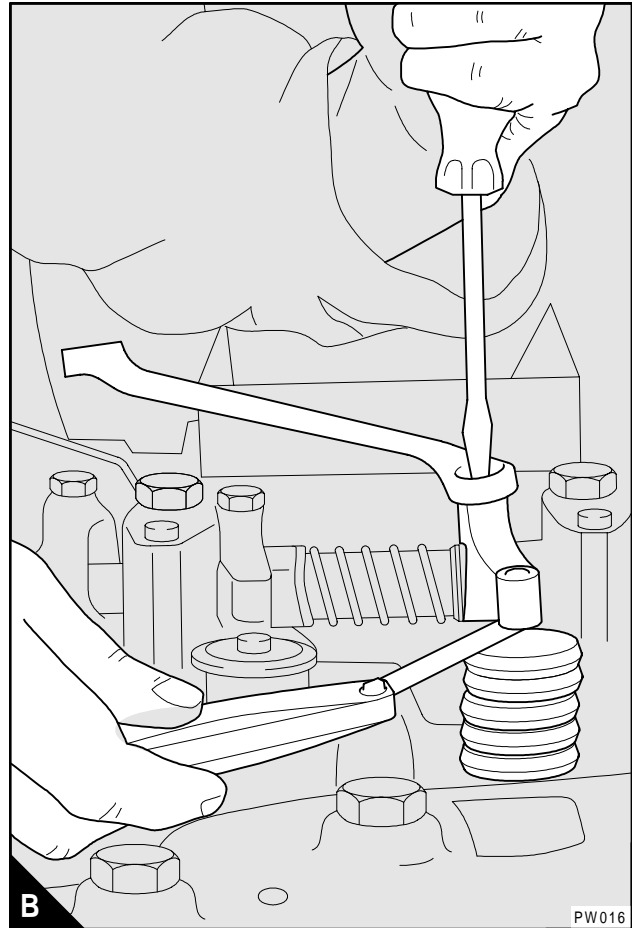

Method two

- 1 Remove the rocker cover, [see operation 12A-1](#).
- 2 Rotate the crankshaft in the normal direction of rotation until the number 1 cylinder is at top dead centre until the inlet valve (A11) of number 6 cylinder has just opened and the exhaust valve (A12) of the same cylinder has not closed fully.
- 3 Check the clearances of the valves (A1, A2, A3, A6, A7, and A10) and adjust them, if necessary.
- 4 Rotate the crankshaft in the normal direction of rotation until the number 6 cylinder is at top dead centre; until the inlet valve (A1) of number 1 cylinder has just opened and the exhaust valve (A2) of the same cylinder has not closed fully.
- 5 Check the clearances of the valves (A4, A5, A8, A9, A11, and A12) and adjust them, if necessary.
- 6 Fit the rocker cover, [see operation 12A-1](#).

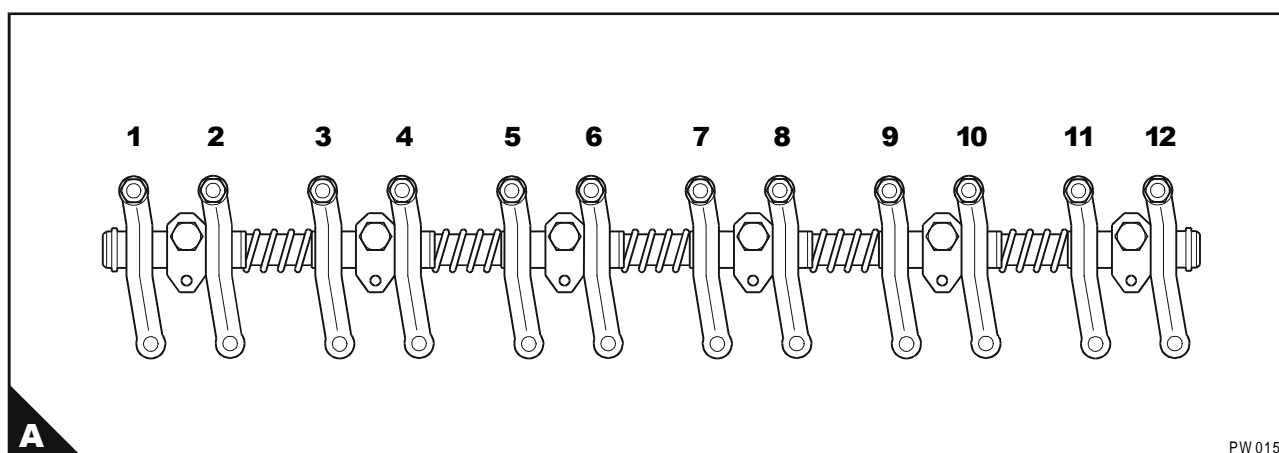
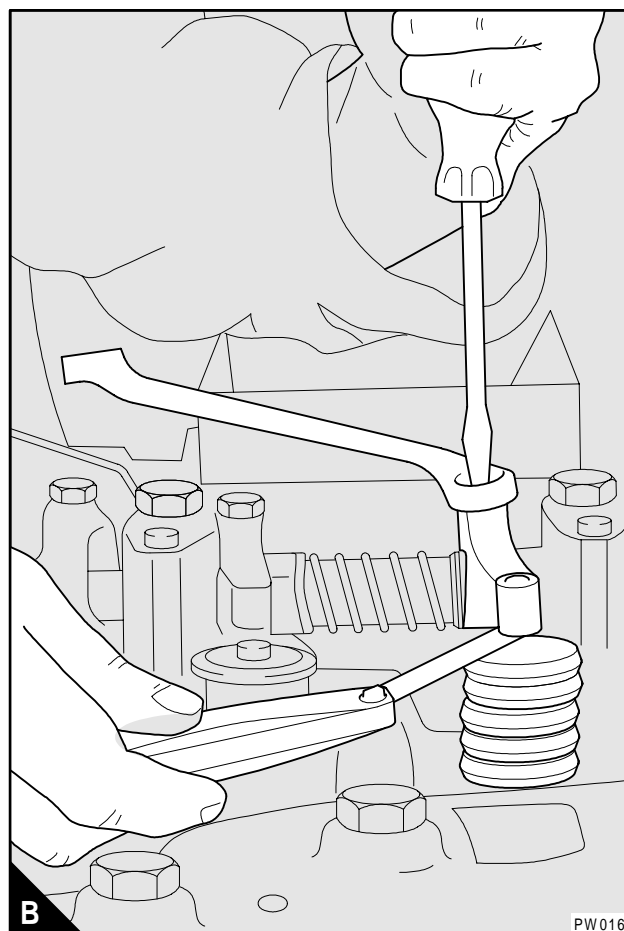

Data and dimensions

Note: This information is given as a guide for personnel engaged on engine overhauls. The dimensions which are shown are those which are mainly used in the factory. The information applies to all engines, unless an engine type code is shown.

Cylinder head

Angle of valve seat:

- Exhaust..... 45° (90° included angle)

- Inlet..... 30° (120° included angle)

Diameter of parent bore for valve guide.....50,70/50,72 mm (1.996/1.997 in)

Leak test pressure200 kPa (29 lbf/in²) 2,04 kgf/cm²

Head thickness106,43/106,93 mm (4.190/4.180 in)

Minimum permissible thickness after head face has been machined..... 106,17 mm (4.180 in)

Maximum permissible distortion of cylinder head0,01 mm (0.004 in) in any 228,6 mm (9 in)

..... 0,15 mm (0.006 in) overall

Inlet valves

Diameter of valve stem7,920/7,938 mm (0.3118/0.3125 in)

Maximum clearance in valve guide.....0,15 mm (0.006 in)

Angle of valve face..... 30°

Depth of valve head below the face of cylinder head0,35 mm (0.014 in)

Seal arrangement Rubber seal assembly fitted to valve guide

Exhaust valves

Diameter of valve stem7,920/7,938 mm (0.3118/0.3125 in)

Maximum clearance in valve guide.....0,15 mm (0.006 in)

Diameter of valve head.....37,26/37,52 mm (1.467/1.477 in)

Angle of valve face..... 45°

Depth of valve head below the face of cylinder head0,35 mm (0.014 in)

Valve guides

Inside diameter7,976/8,019 mm (0.3140/0.3157 in)

Outside diameter..... 14,341/14,361 mm (0.5646/0.5654 in)

Interference fit of valve guide in cylinder head.....0,053/0,038 mm (0.0021/0.0015 in)

Overall length:

- Inlet.....60,73 mm (2.391 in)

- Exhaust.....60,73 mm (2.391 in)

Protrusion from bottom of recess.....22,05/22,56 mm (0.868/0.888 in)

Inlet valve springs

Free length.....58,22 mm (2.292 in)

Valve closed length..... 51 mm (2.292 in) under a load of, 333/369 N (75/83 lbf) 33/36 kgf

Valve open length 38 mm (1.497 in) under a load of, 921/965 N (207/217 lbf) 92/96 kgf

Exhaust valve springs

Free length.....62,18 mm (2.448 in)

Valve closed length..... 50,29 mm (1.980 in) under a load of, 538/574 N (80/88 lbf) 36,3/39,9 kgf

Valve open length 38,86 mm (1.530 in) under a load of, 1063/1117 N (239/251 lbf) 108,4/113,9 kgf

continued

Tappets

Diameter of tappet.....	28,435/28,448 mm (1.1195/1.1200 in)
Length of tappet.....	74,24/75,01 mm (2.923/2.953 in)
Clearance of tappet in cylinder block.....	0,064/0,102 mm (0.0025/0.0040 in)
Clearance of roller to tappet wall	0,666 mm (0.026 in)

Rocker shaft

Outside diameter	21,567/21,593 mm (0.8491/0.8501 in)
------------------------	-------------------------------------

Rocker shaft springs

Quantity	5
Free length	103,1 mm (4.06 in)
Length under load of 31 N (7 lbf) 3,18 kgf	56,6 mm (2.07 in)
Diameter	25,9 mm (1.02 in)

Rocker levers and bushes

Internal diameter of bush.....	21,69 mm (0.854 in)
Clearance between rocker lever bush and rocker shaft	0,048/0,124 mm (0.0019/0.0049 in)
Push rod length	268,980/269,743 mm (10.5898/10.6198 in)

13A

Piston and connecting rod assemblies

General description

The aluminium alloy pistons of the WK and WL engines have a cast iron insert for the top piston ring.

The pistons of the WM and WN engines have an aluminium alloy skirt and a steel piston crown. The steel crown compensates for increased combustion pressures, and can be removed from the piston skirt, when the piston assembly is dismantled.

Both types of piston have recesses in the crown to allow clearance for the inlet and exhaust valves. The combustion bowl is off-centre.

A variation in the aluminium alloy along the length of the piston skirt controls expansion of the piston.

Each piston has two tapered compression rings and an oil control ring. The grooves for the piston rings have the same shape as their rings. The top compression ring is marked "TOP-UP" on its upper face, the second compression ring is marked "2nd-UP" on its upper face. The oil control ring is not marked, and new rings may be fitted either way up. The top compression ring has a round edge, the edge of the second compression ring is at an angle.

Combustion pressure is allowed to pass through the ring gaps to the underside of the compression rings. This maintains the correct contact between the face of the piston rings and the cylinder bore, to improve performance and reduce oil loss.

Axial location of the fully floating gudgeon pin is by circlips.

The connecting rods are "H" section forgings of steel. The small end is wedge shaped to improve strength and reliability. The overall length of the connecting rod is reduced by an angle of tilt to the big end bearing.

Jets fitted in the cylinder block spray lubricating oil onto the inner surface of the piston to cool the piston.

Big end bearing

To remove and to fit

13A-1

To remove

- 1 Drain the engine lubricating oil.
- 2 Remove the lubricating oil sump, see operation 19A-8.
- 3 Remove the lubricating oil strainer and suction pipe, see operation 19A-9.
- 4 Rotate the crankshaft until access to the relevant connecting rod setscrews is possible.
- 5 Remove the setscrews from the connecting rod.
- 6 Remove the bearing cap (A) together with the lower shell-bearing.
- 7 Carefully push the connecting rod up the cylinder bore (B), just enough to allow access to the upper shell-bearing.
- 8 Remove the upper half of the shell bearing from the connecting rod. Keep the bearings of the connecting rods and caps together, for correct assembly.

To fit

- 1 Clean the bearing faces of the connecting rod and the crank pin. Clean the threads of the connecting rod and the threads of the setscrews.
 - 2 Clean the complete bearing and lubricate the bearing surface and the crank pin with clean engine lubricating oil.
 - 3 Fit the upper half of the shell bearing to the connecting rod, ensure that the locating tag is fitted correctly in its recess.
 - 4 Fit the connecting rod to the crankpin; ensure that the short side (C1) of the connecting rod is toward the camshaft side of the engine.
 - 5 Fit the lower shell-bearing into the cap, ensure that the locating tag (A2) is fitted correctly in its recess.
 - 6 Lubricate lightly the threads and the thrust faces of the setscrews with clean engine lubricating oil.
 - 7 Hold the bearing cap in position on the connecting rod. Ensure that the assembly number on the cap is the same as the number on the connecting rod and that both of the assembly numbers are on the same side (A1).
- Caution:** Do not try to recondition the threads in the connecting rod. If the threads are damaged, renew the connecting rod.
- 8 Fit the setscrews by hand. If they do not fit freely by hand, fit new setscrews. If the new setscrews do not fit freely by hand, renew the connecting rod.

Continued

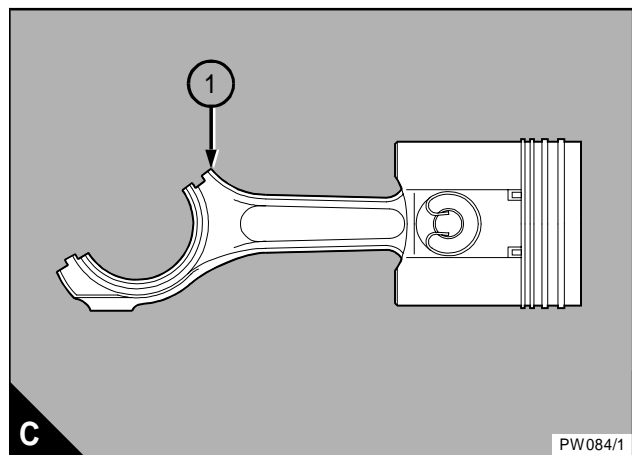
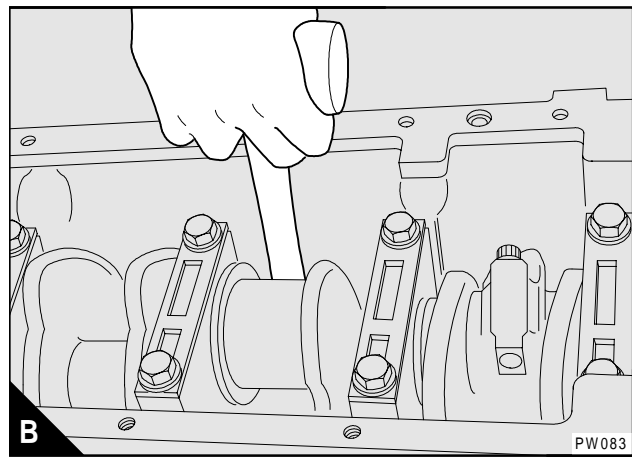
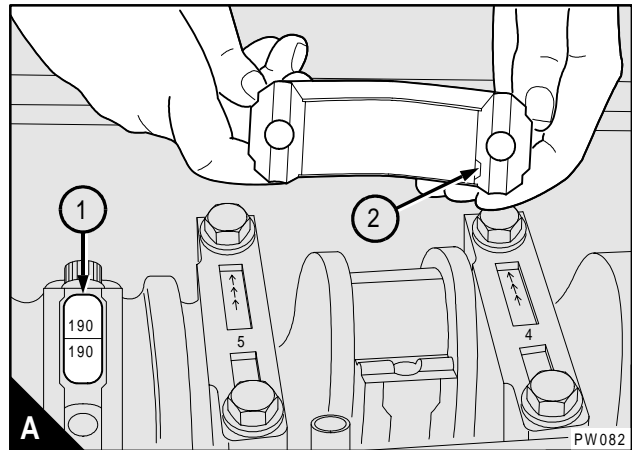

- 9** Tighten the setscrews gradually and evenly to 156 Nm (115 lbf ft) 15,9 kgf m.
- 10** Ensure that the crankshaft rotates freely.
- 11** Fit the lubricating oil strainer and suction pipe, [see operation 19A-9](#).
- 12** Fit the lubricating oil sump, [see operation 19A-8](#).
- 13** Fill the sump to the correct level with lubricating oil of an approved grade.

To inspect

13A-2

Check the bearings and the crank pin for wear or other damage.

Measure the crank pins and compare the measurements with those in data and dimensions.

13A

Piston and connecting rod assembly

To remove and to fit

13A-3

To remove

- 1 Drain the lubricating oil.
- 2 Drain the cooling system.
- 3 Remove the cylinder head assembly, [see operation 12A-6](#).
- 4 Remove all carbon from the top of the bores of the cylinder liners.
- 5 Remove the lubricating oil sump, [see operation 19A-8](#).
- 6 Remove the lubricating oil strainer and suction pipe, [see operation 19A-9](#).
- 7 Remove the setscrews (C5) for the big end bearing cap and remove the big end bearing cap (A).
- 8 Push the piston and the connecting rod assembly (B) out through the top of their cylinders.
- 9 Put the shell-bearings (C2 and C3) and the bearing cap (C4) with the piston and connecting rod (C1) assembly; mark the components to ensure that they are returned to the correct cylinder.
- 10 Inspect the crank pin for damage.

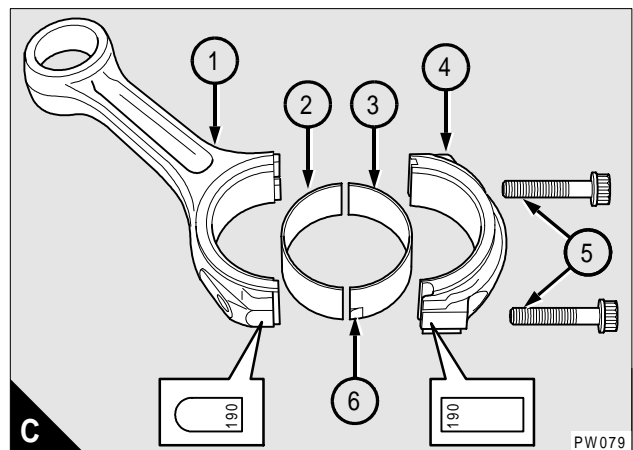
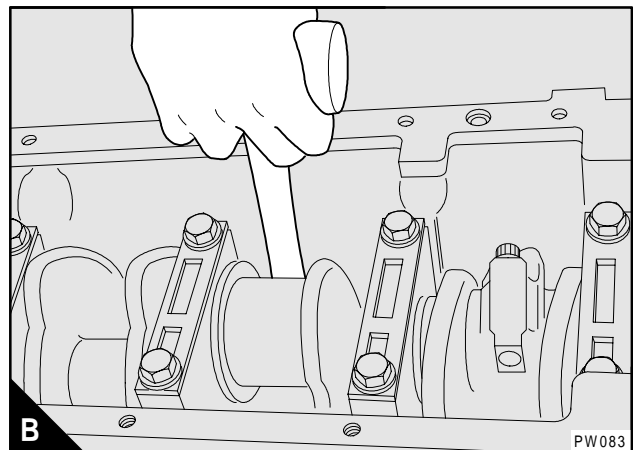
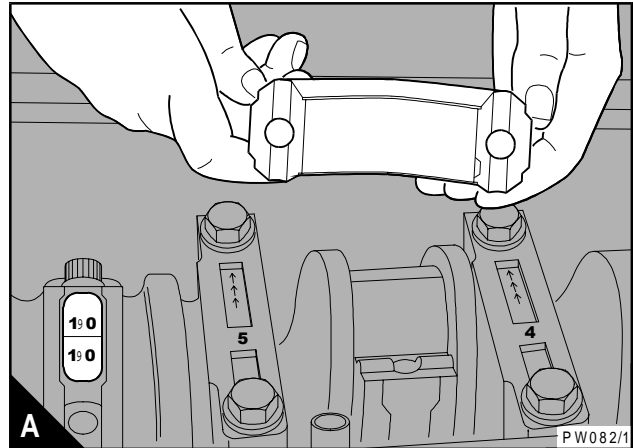

To fit

Caution: *If the original piston is used, ensure that it is assembled to the correct connecting rod and that it is used in the original cylinder.*

- 1 Ensure that the piston, the cylinder bore, the crank pin and the big end of the connecting rod is clean.
- 2 Clean the threads of the connecting rod (B1) and the threads of the setcrews (B5).
- 3 The piston has drain holes for the lubricating oil, check that these holes are free of debris.
- 4 Lubricate the piston and the cylinder liner with clean engine lubricating oil.
- 5 Rotate the crankshaft until access to fit the connecting rod setscrews is possible.
- 6 Clean the shell bearings (B2 and B3) and lubricate the bearing surface and the crank pin with clean engine lubricating oil.
- 7 Fit the upper shell-bearing (B2) to the connecting rod, ensure that the locating tag is fitted correctly in its recess.
- 8 Put the piston ring gaps 120° apart and compress the rings with a suitable tool.
- 9 Pass the connecting rod and piston assembly into the cylinder. Ensure that the "camside" mark (13A.03/C1) on the piston crown is towards the camshaft side of the engine.
- 10 Push the piston and connecting rod assembly through the piston ring clamp and onto the crank pin. Ensure that the short side (13A.03/C1) of the connecting rod is towards the camshaft side of the engine.
- 11 Fit the lower shell-bearing onto its cap, ensure that the locating tag is fitted correctly in its recess (A2).
- 12 Lubricate lightly the threads of the setscrews with clean engine lubricating oil.
- 13 Hold the bearing cap in position on the connecting rod. Ensure that the assembly number on the cap is the same as the number on the connecting rod and that both of the assembly numbers are on the same side (A1).

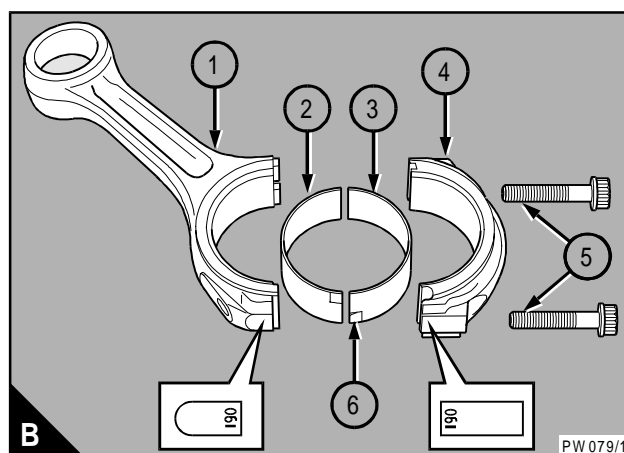
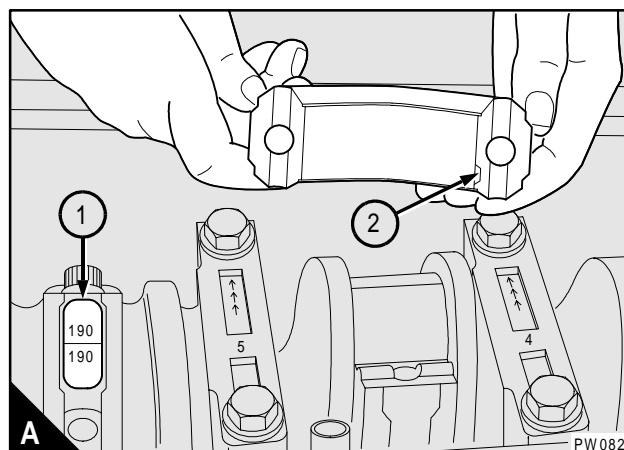

Continued

13A

Caution: Do not try to recondition the threads in the connecting rod. If the threads are damaged, renew the connecting rod.

14 Fit the setscrews by hand. If they do not fit freely by hand, fit new setscrews. If the new setscrews do not fit freely by hand, renew the connecting rod.

15 Tighten the setscrews gradually and evenly to 156 Nm (115 lbf ft) 15,9 kgf m.

16 Ensure that the crankshaft rotates freely.

17 Check the side clearance of the connecting rod big-end, see data and dimensions.

18 Fit the lubricating oil strainer and suction pipe, see operation 19A-9.

19 Fit the lubricating oil sump, see operation 19A-8.

20 Fit the cylinder head assembly, see operation 12A-6.

21 Fill the sump to the correct level with lubricating oil of an approved grade.

22 Fill the cooling system.

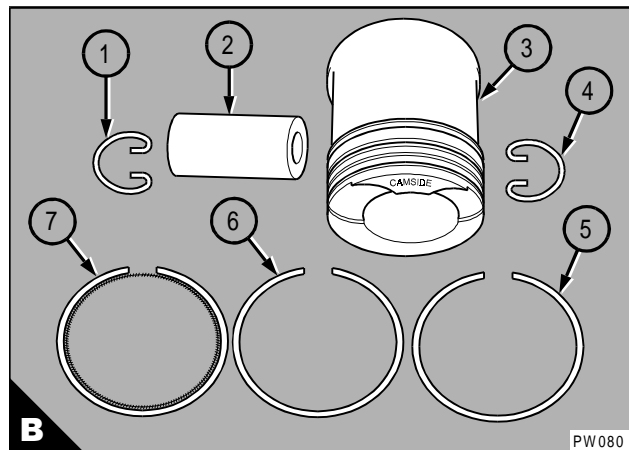
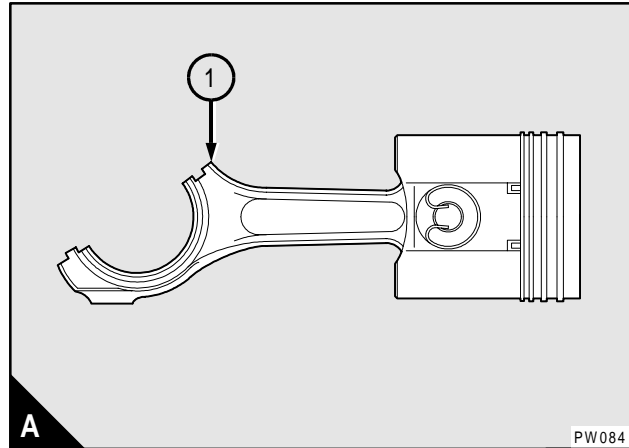

To dismantle and assemble (WK and WL engines)

13A-4

To dismantle

Note: Mark the components to ensure that they are returned to the correct cylinder.

1 Remove the piston rings (B5, B6 and B7), see operation 13A-9.

2 Remove the circlips (B1 and B4) which retain the gudgeon pin (B2) and push the gudgeon pin out of the piston (B3) by hand.

3 Separate the connecting rod from the piston.

To assemble

1 Clean the bore of the small end bush and lubricate it with clean engine lubricating oil.

2 Fit a circlip (B1) in the circlip groove of one of the gudgeon pin bosses. Ensure that it fits correctly in the groove.

Caution: If the original piston is used, ensure that it is assembled to the correct connecting rod and that it is used in the original cylinder.

3 With the piston (B3) upside down, put the connecting rod in position. Ensure that the short side of the connecting rod (A1) is on the same side as the "camside" mark (B) on the piston crown.

4 Lubricate the gudgeon pin and the gudgeon pin bosses in the piston with clean engine lubricating oil.

5 Push in the gudgeon pin (B2) towards the circlip.

6 Fit the other circlip (B4) in the groove in the other gudgeon pin boss. Ensure that it fits correctly in the groove.

7 Fit the piston rings, see operation 13A-9.

To dismantle and assemble (WM and WN engines)

13A-5

To dismantle

Note: Mark the components to ensure that they are returned to the correct cylinder. Mark the piston skirt and the piston crown to ensure correct assembly.

- 1 Remove the piston rings, [see operation 13A-9](#).
- 2 Remove the circlips which retain the gudgeon pin and push the gudgeon pin out of the piston by hand (A).
- 3 Separate the connecting rod from the piston.
- 4 Remove the piston skirt (B1) from the piston crown (B2).

To assemble

- 1 Clean the bore of the small end bush and lubricate it with clean engine lubricating oil.
- 2 Put the piston skirt (B1) on the piston crown (B2), ensure that the marks made earlier are aligned.
- 3 Fit a circlip (A) in the circlip groove of one of the gudgeon pin bosses. Ensure that it fits correctly in the groove.

Caution: *If the original piston is used, ensure that it is assembled to the correct connecting rod and that it is used in the original cylinder.*

- 4 With the piston upside down, put the connecting rod in position. Ensure that the short side of the connecting rod is on the same side as the “camside” mark on the piston crown.

5 Lubricate the gudgeon pin and the gudgeon pin bosses in the piston with clean engine lubricating oil.

6 Push in the gudgeon pin towards the circlip.

7 Fit the other circlip in the groove in the other gudgeon pin boss. Ensure that it fits correctly in the groove.

8 Fit the piston rings, [see operation 13A-9](#).

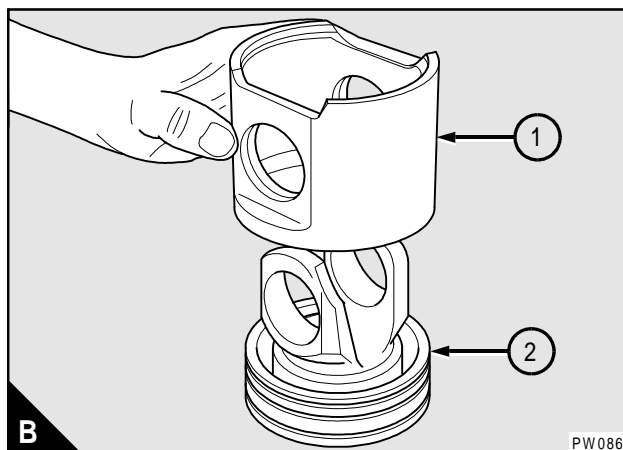
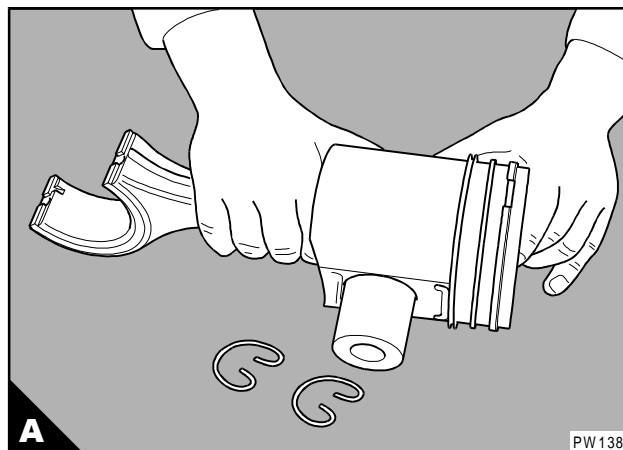

13A

To inspect

13A-6

Special tools:

Piston groove gauges 21825955

- 1 Check the piston for wear and other damage.
- 2 Check that the piston rings move freely in their grooves and that the piston rings are not broken.
- 3 Remove the piston rings, [see operation 13A-9](#).
- 4 Clean the piston ring grooves and the piston rings.
- 5 Fit the piston groove gauge 21825955 to the top compression ring groove, measure and record the overall diameter of the piston and the gauge (A).
- 6 Fit the piston groove gauge 21825955 to the second compression ring groove, measure and record the overall diameter of the piston and the gauge (B)
- 7 Fit a new oil control ring in its groove and check for wear of the ring groove with feeler gauges (C).
- 8 Measure and record the diameter of the piston skirt (D). Measured at 90° from the gudgeon pin, at a point 27,43 mm (1.08 in) below the oil control ring.

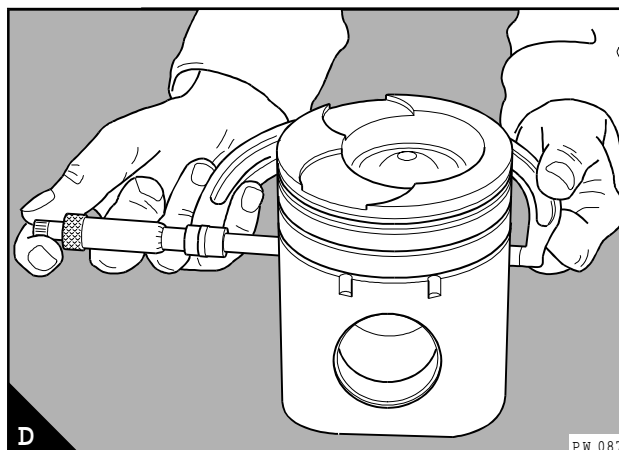
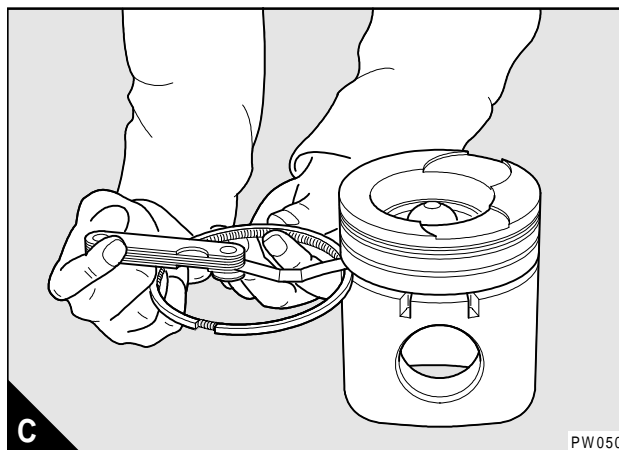
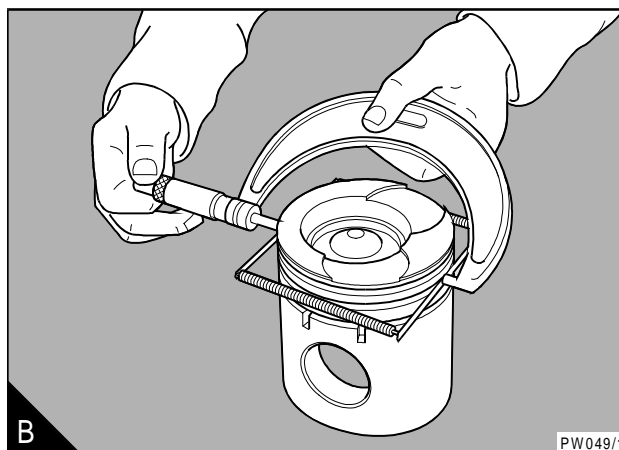
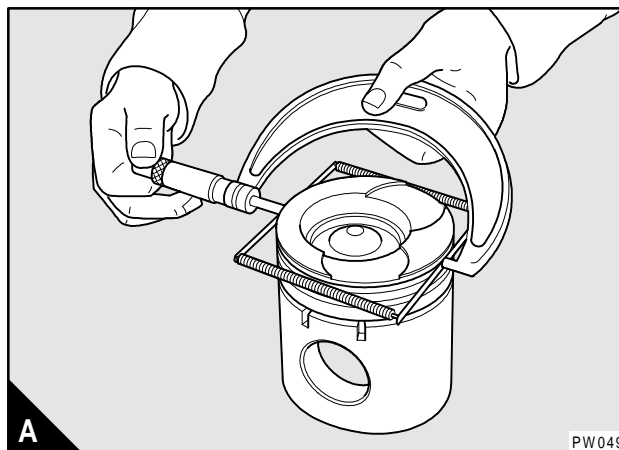

Connecting rod

To inspect

13A-7

- 1 Check the connecting rod for distortion (A).

Note: The large and small end bores must be square and parallel with each other within the limits of $\pm 0,127$ mm (0.005 in) measured 127 mm (5.0 in) each side of the connecting rod axis on a test mandrel.

- 2 Check the small end bush for wear or for other damage and renew it, if necessary.
- 3 Check the fit of the gudgeon pin in the small end bush and check the gudgeon pin for wear, see data and dimensions.

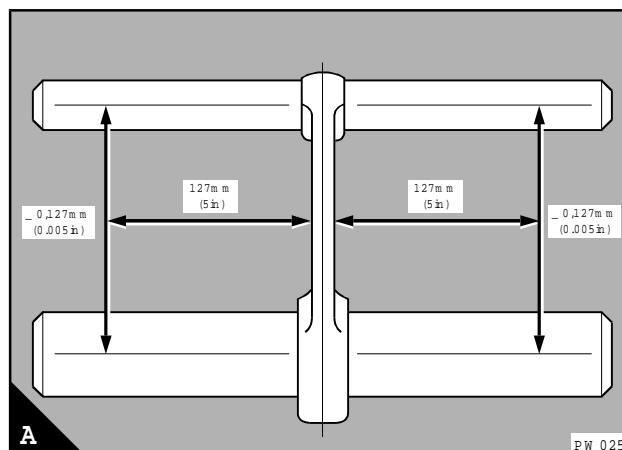

Small end bush

To remove and to fit

13A-8

- 1 Press out the old bush with a suitable adaptor.
- 2 Clean the connecting rod bore and remove any sharp edges.
- 3 Press in the new bush. Ensure that the lubrication hole in the bush is on the same side as, and is aligned with, the hole in the top of the connecting rod.
- 4 The connecting rods on all of the engines have a small end that is wedge shaped. After the small end bush has been fitted, machine the bush to the shape of the small end and remove any sharp edges.

13A

Piston rings

To remove and to fit

13A-9

Caution: Only increase the ring gaps enough to ensure that the ends of the rings do not damage the piston.

To remove

1 Remove the piston rings with a suitable ring expander (A1).

To fit

1 Use a suitable ring expander (A1) to fit the piston rings. Keep the rings with their relevant pistons, for correct assembly.

2 Ensure that the coil spring is fitted into the oil control ring. Ensure that the gap in the coil spring and the gap in the latch pin of the coil spring are 180° apart

To inspect

13A-10

Caution: The coil spring must be fitted to the oil control ring when the gap is measured.

1 Clean all carbon from the top of the cylinder liners.

2 Fit each piston ring (B2) in the top part of the cylinder liner, measure and record the ring gap with feeler gauges (B1).

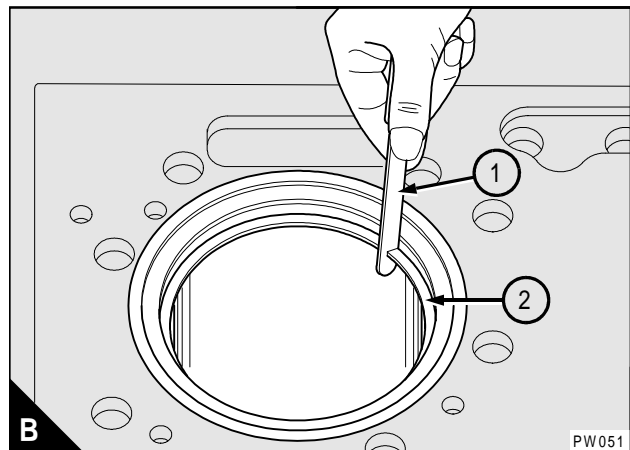
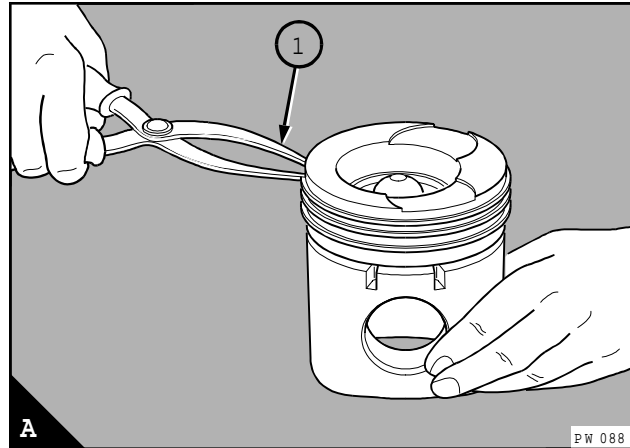

Data and dimensions

Note: This information is given as a guide for personnel engaged on engine overhauls. The dimensions which are shown are those which are mainly used in the factory. The information applies to all engines, unless an engine type code is shown.

Pistons

Type:

- WK and WL engines..... One piece, all aluminium. "Toroidal" combustion bowl
- WM and WN engines Two piece, high-pressure. Steel crown. "Toroidal" combustion bowl
- Diameter of the bore for the gudgeon pin..... 46,380/48,856 mm (1.9235/1.9255 in)
- Cooling jets per piston 2

Piston rings

Oil control ring to groove clearance..... 0,0508/0,102 mm (0.0020/0.0040 in)

Top ring groove width, measured over (0.1150 in) gauge pins:

- WK and WL 108,697/109,519 mm (4.2794/4.3118 in)
- WM and WN engines 113,477/114,338 mm (4.4676/4.5015 in)

Second ring width, measured over (0.1150 in) gauge pins:

- WK and WL engines..... 108,697/109,519 mm (4.2794/4.3118 in)
- WM and WN engines 116,108/116,967 mm (4.5712/4.6050 in)

Ring gap with new cylinder liner:

- Top ring 0,356/0,66 mm (0.014/0.026 in)
- Second ring 1,65/1,91 mm (0.065/0.075 in)
- Oil control ring for WK and WL engines 0,31/0,56 mm (0.012/0.022 in)
- Oil control ring for WM and WN engines 0,356/0,66 mm (0.014/0.026 in)

Connecting rods

Type..... 'H' section, wedge shape small end

Length between centres 219,100/219,050 mm (8.626/8.624 in)

Small end:

- Diameter of parent bore 48,856/48,900 mm (1.9235/1.9255 in)
- Diameter of bush (fitted)..... 46,373/46,380 mm (1.8257/1.8260 in)

Big end:

- Side clearance to crankshaft 0,419/0,300 mm (0.0165/0.0120 in)
- Diameter of parent bore 85,000/85,131 mm (3.3516/3.3516 in)
- Diameter of bearing (fitted)..... 80,000/80,100 mm (3.1524/3.1544 in)

Gudgeon pins :

- Type Fully floating
- Outside diameter 46,352/46,358 mm (1.8249/1.8251 in)
- Clearance fit in piston boss 0,015/0,0028 mm (0.0006/0.0011 in)

14A

Crankshaft assembly

General description

The crankshaft is a steel forging with seven main journals. All the crankshaft journals and the crank pins are induction hardened.

End-float is controlled by thrust washers that are an integral part of the rear main bearing, and shall be referred to as thrust bearings in this manual. The area of the bearing surfaces of the seven main bearings is the same. All the main bearings have location tags.

An integral damper, with a rubber insert is built into the crankshaft pulley. The location of the pulley / damper assembly is by a key in the crankshaft nose. The assembly is held in position by an interference fit, and by a retainer plate and three setscrews. The pulley / damper assembly must be heated before it is fitted on the crankshaft.

The rear oil seal can be renewed without removing the flywheel housing.

14A

Crankshaft pulley/damper assembly

To remove and to fit

14A-1

Special tools:

Crankshaft pulley puller 21825965

Consumable products

POWERPART Silicone rubber sealant

To remove

Note: Before removing the pulley/ damper assembly check for alignment, [see operation 14A-2](#).

- 1 Drain the lubricating system.
- 2 Remove the drive belt, [see operation 21A-7](#).
- 3 Release and remove the three setscrews (A) which hold the retainer plate of the pulley/ damper assembly.
- 4 Remove the retainer plate (A).
- 5 Use the puller 21825965 to remove the pulley/ damper assembly (C).

To fit

Warning! Use suitable gloves to protect the hands from heat.

- 1 Heat the pulley/ damper assembly. Do not exceed 198 °C (388 °F).

Caution: Do not try to fit a cold pulley/damper assembly as this will damage the crankshaft.

- 2 Put the assembly on the crankshaft, engage the drive key and push the pulley fully towards the rear.
- 3 Clean off the old sealant from the retainer plate and from the pulley/damper assembly.
- 4 Put POWERPART Silicone rubber sealant on the inner face of the retainer plate and fit the retainer plate (B).
- 5 Lubricate lightly the threads of the setscrews for the retainer plate with clean engine lubricating oil.
- 6 Fit and tighten the setscrews gradually and evenly to 136 Nm (100 lbf ft) 13,8 kgf m.
- 7 Fit the drive belt, [see operation 21A-7](#).
- 8 Fill the lubricating system to the correct level with an approved lubricating oil.

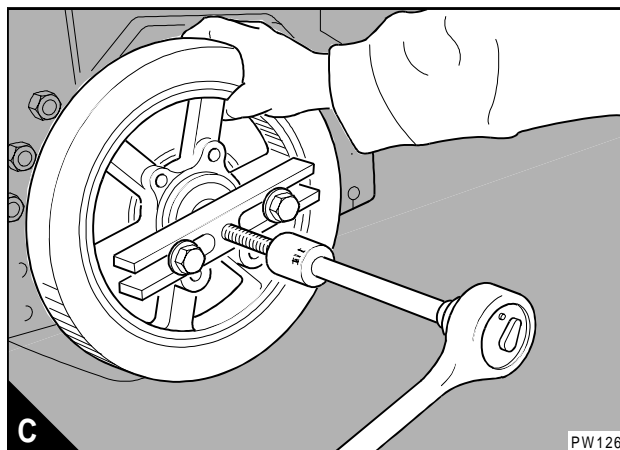
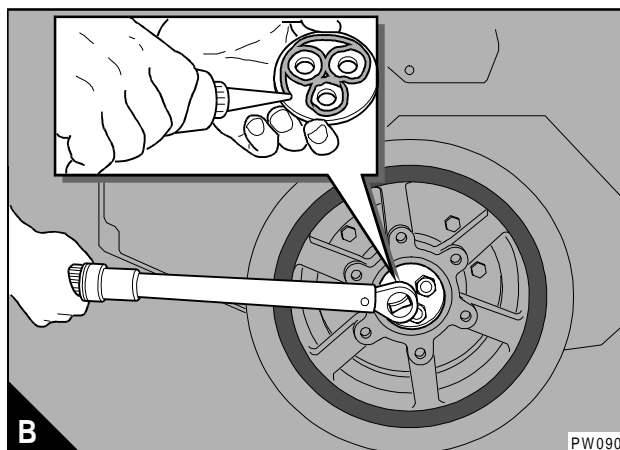
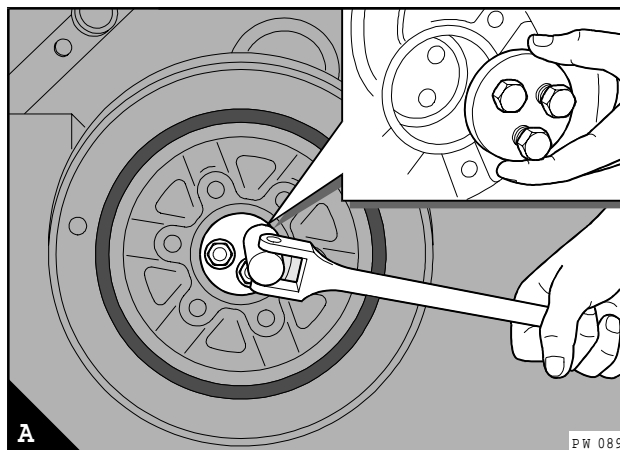

To inspect**14A-2**

Clean the components and check for damage.

The assembly must be renewed if:

- there are cracks in the rubber (A2)
- the rubber is damaged by oil
- the component alignment marks (A1) exceed the tolerance in data and dimensions.

Measure and record damper alignment (B) at four places (B1) 90° apart on the damper face. Ensure that the crankshaft is at the same end of its axial movement for each measurement. This eliminates crankshaft end-float from the measurement.

When the pulley/ damper assembly is removed from the crankshaft, measure and record the run-out of the damper mounting face on the crankshaft palm.

Compare all the readings with data and dimensions.

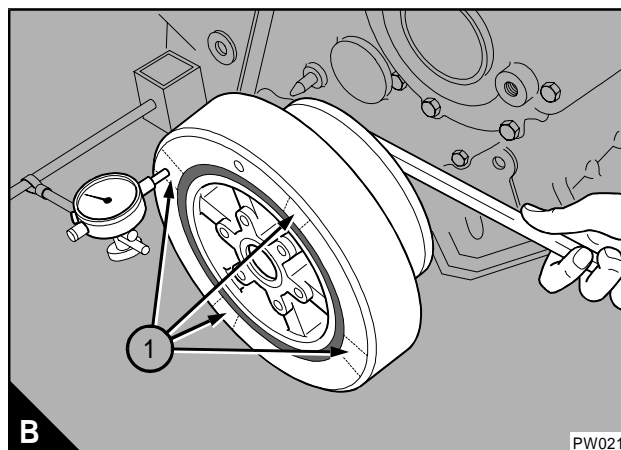
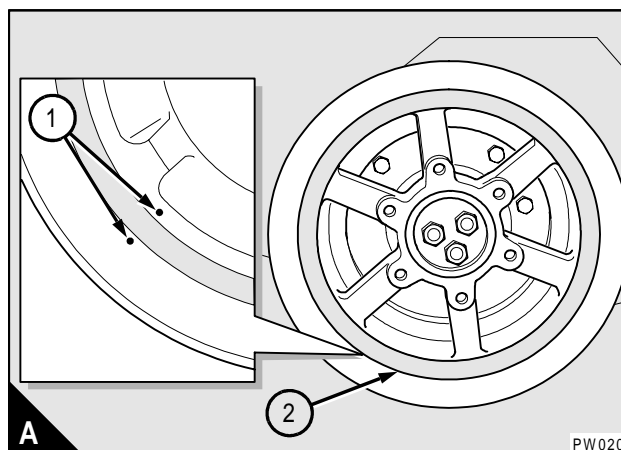

14A

Rear oil seal housing assembly

Cautions:

- If the oil seal housing is removed, the rear oil seal and its wear sleeve must be renewed.
- Renew the rear oil seal and the wear sleeve as a unit, do not separate them.
- The flywheel housing does not have to be removed to renew the rear oil seal.

To remove and to fit the oil seal housing

14A-3

Special tools:

Rear oil seal installer 21825963

Consumable products:

POWERPART Compound

To remove

- 1 Drain the lubricating oil.
- 2 Remove the lubricating oil sump, see operation 19A-8.
- 3 Remove the drive components from the rear end of the engine.
- 4 Remove the flywheel, see operation 22A-1.
- 5 Remove the four setscrews which pass through the flange of the sump and into the bottom of the seal housing.
- 6 Remove the six setscrews which retain the seal housing to the cylinder block.
- 7 Remove the rear oil seal and housing assembly (A). Remove and discard the old length of seal from between the housing and the cylinder block.
- 8 Hit carefully the face of the wear sleeve with a hammer to loosen the wear sleeve from the crankshaft (B).
- 9 Remove the wear sleeve from the crankshaft.

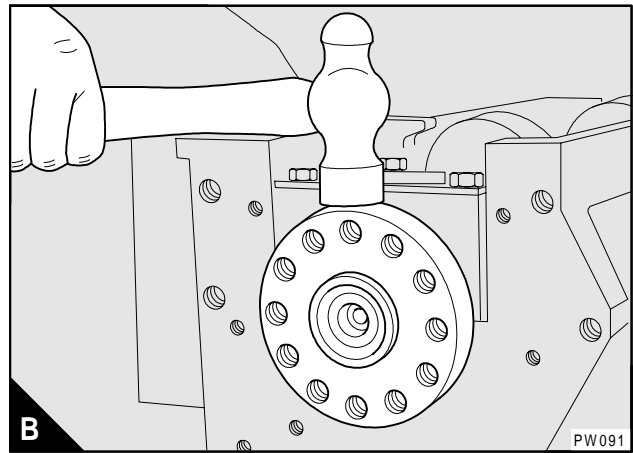
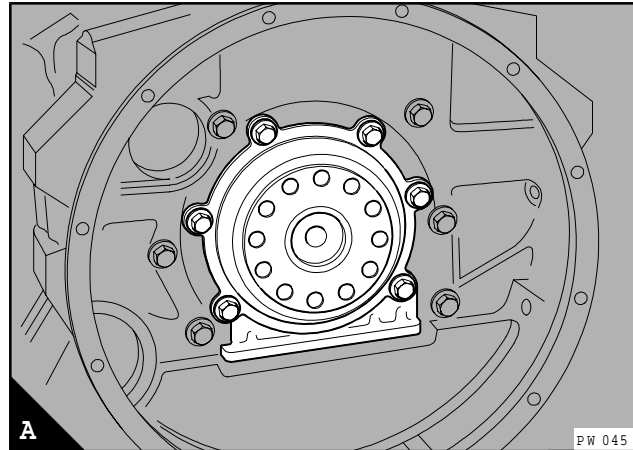

To fit

- 1 Clean the faces of the cylinder block, the oil seal housing and the crankshaft palm.
- 2 Fit a new to the oil seal housing.
- 3 Fit the guide adaptor from tool 21825963 to the end of the crankshaft (A).
- 4 Put the housing (B2) into position on the engine, fit and tighten the setscrews finger tight.
- 5 Apply POWERPART Compound to the outer diameter of the oil seal and to the inner diameter of the wear sleeve.

Caution: *Fit the rear oil seal and the wear sleeve as a unit, do not separate them.*

- 6 Put a new oil seal and wear sleeve assembly into position (B1) on the guide adaptor (B3) from tool 21825963.

- 7 Fit the plate from tool 21825963 to the guide adaptor. Tighten the nut of the tool (C) until the plate comes into contact with the face of the housing.

Note: When the plate from tool 21825963 contacts the face of the seal housing, the oil seal and the wear sleeve are in their correct positions.

Continued

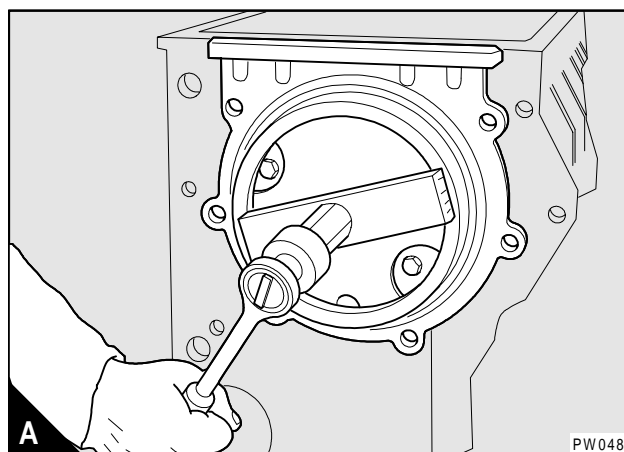
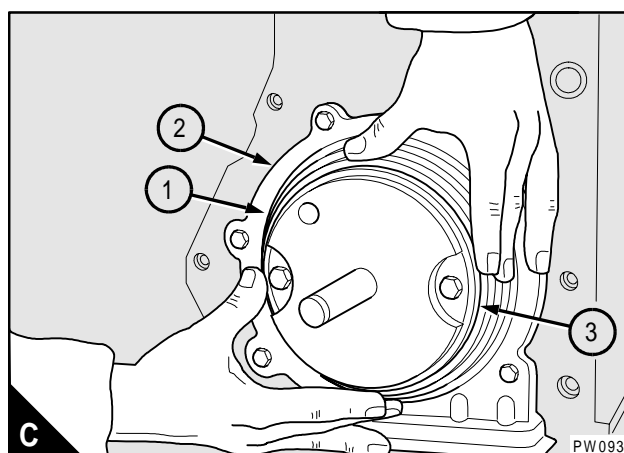
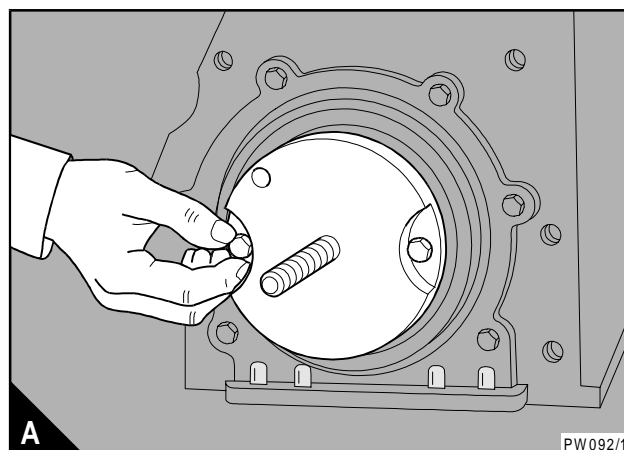

14A

- 8 Use a straight edge to check that the seal housing is level with the cylinder block face (A).
- 9 Tighten the setscrews to 24 Nm (18 lbf ft) 2,5 kgf m.
- 10 Cut off the excess seal length (B1) so that it is level with the face of the cylinder block (B).
- 11 Remove the tool 21825963.
- 12 Fit the lubricating oil sump, [see operation 19A-8](#).
- 13 Fit the flywheel, [see operation 22A-1](#).
- 14 Fit the drive components to the rear end of the engine.
- 15 Fill the lubricating oil sump to the correct level with an approved lubricating oil.

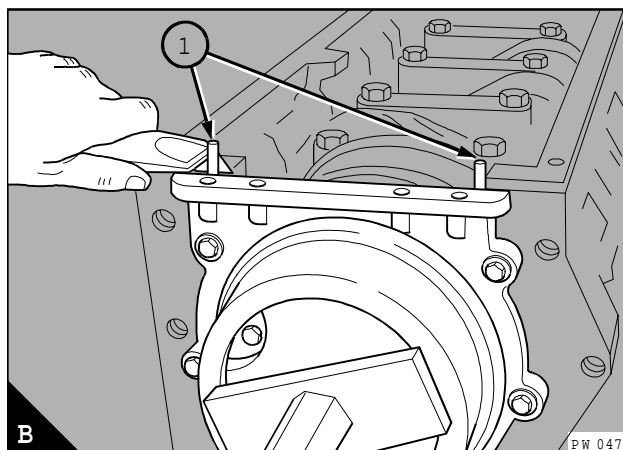
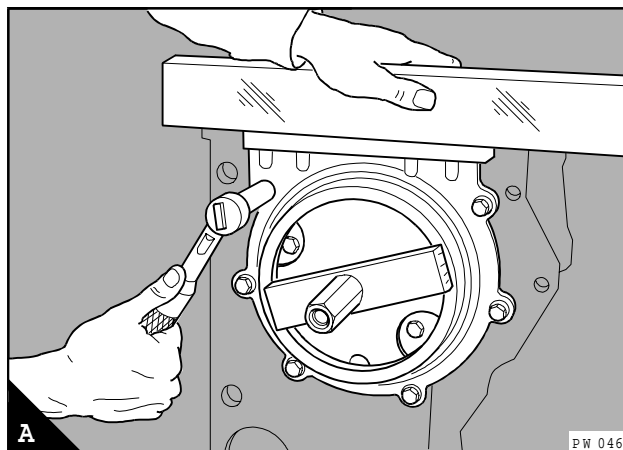

To renew the rear oil seal and wear sleeve assembly

14A-4

Special tools:

Remover for the wear sleeve of the rear oil seal ZTSE 4404

Rear oil seal installer 21825963

Note:

- The oil seal housing does not have to be removed to renew the rear oil seal and wear sleeve assembly.
- The flywheel housing does not have to be removed to renew the rear oil seal and wear sleeve assembly.
- Renew the rear oil seal and the wear sleeve as a unit, do not separate them.

To renew

- 1 Drain the lubricating oil.
 - 2 Remove the drive components from the rear end of the engine.
 - 3 Remove the flywheel, [see operation 22A-1](#).
 - 4 Fit two self-tapping screws (A2) into the front face (A1) of the oil seal.
 - 5 Carefully lever the seal from the seal housing (A).
- Caution:** Do not damage the seal housing or the crankshaft palm.
- 6 Fit the remover tool ZTSE 4404 (B) and (C).
 - 7 Fit a square headed lever (D1) into the 12,7 mm (0.5 in) hole in the front face of the remover tool (D3).
 - 8 Fit a spanner (D4) to the threaded rod (D2) of the remover tool. Hold the lever and tighten the threaded rod with the spanner to remove the wear sleeve.
 - 9 Discard the oil seal and wear sleeve assembly.
 - 10 Clean the oil seal housing and the crankshaft palm.

Continued

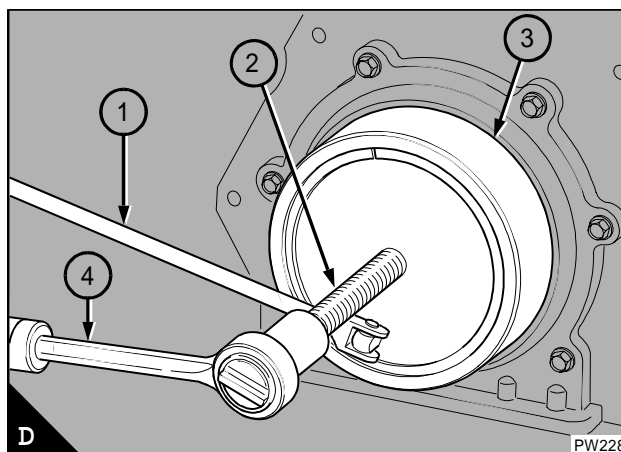
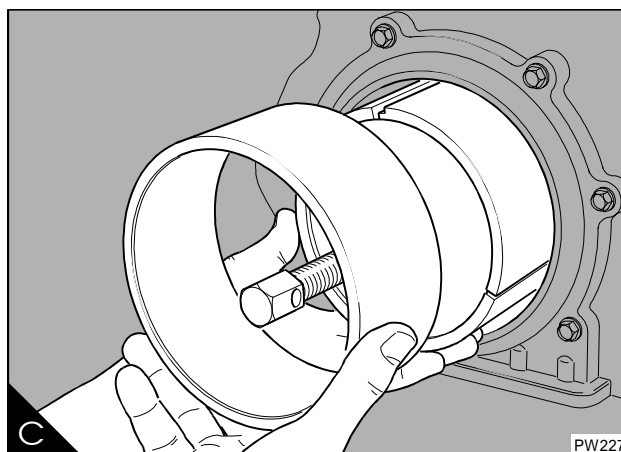
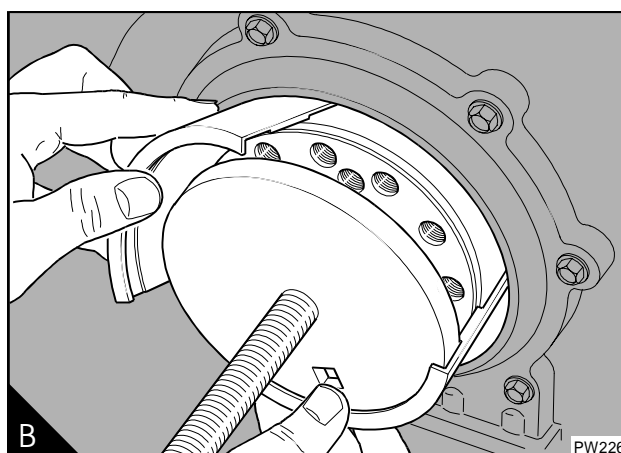
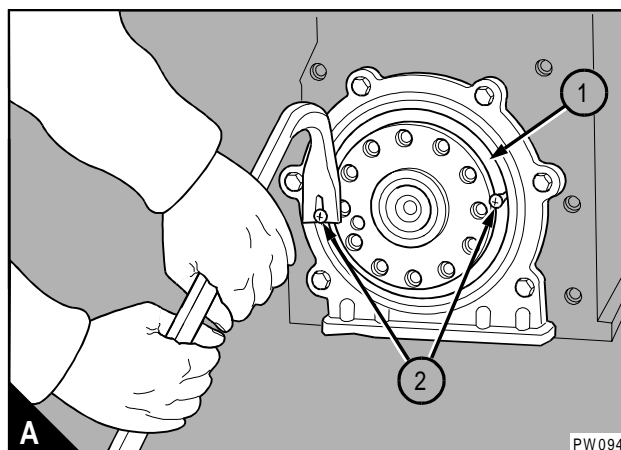

14A

11 Fit the guide adaptor (A) from tool 21825963 to the end of the crankshaft.

12 Apply POWERPART Compound to the outer diameter of the oil seal and to the inner diameter of the wear sleeve.

Caution: *Fit the rear oil seal and the wear sleeve as a unit, do not separate them.*

13 Put the oil seal and wear sleeve assembly (B1) into position on the guide adaptor (B3) from tool 21825963.

14 Fit the plate from tool 21825963 to the guide adaptor. Tighten the nut of the tool until the plate comes into contact with the face of the housing (C).

Note: When the plate from tool 21825963 comes into contact with the face of the seal housing, the oil seal and the wear sleeve are in their correct positions.

15 Fit the flywheel, [see operation 22A-1](#).

16 Fit the drive components to the rear end of the engine.

17 Fill the lubricating oil sump to the correct level with an approved lubricating oil.

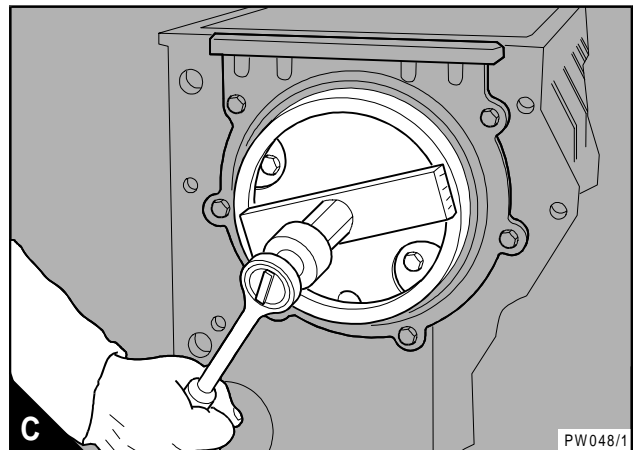
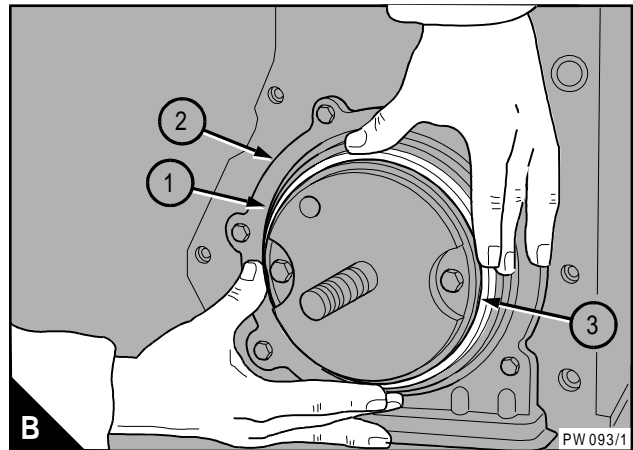
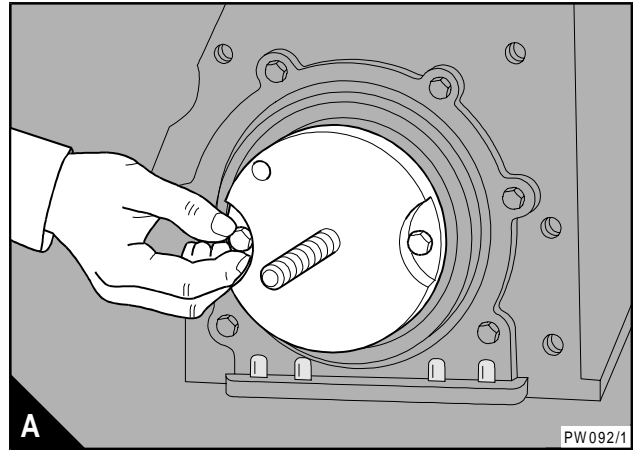

Crankshaft

To remove and to fit

14A-5

Warning! Use lift equipment or obtain assistance to lift heavy engine components such as the flywheel housing, flywheel and crankshaft.

To remove

- 1 Before the engine is removed from the application, drain the lubricating oil and the coolant.
- 2 Remove the lubricating oil sump, see operation 19A-8.
- 3 Remove the fan, the drive belt, the fan drive pulley and housing, and the coolant pump, see section 21.
- 4 Remove the pulley/damper assembly, see operation 14A-1.
- 5 Remove the alternator and its mounting bracket, see operation 23A-1.
- 6 Remove the compressor and its drive assembly, if one is fitted, see operation 24A-1.
- 7 Remove the timing case cover, see operation 15A-1.
- 8 Remove the high-pressure pump, see operation 19A-2.
- 9 Remove the timing gears and the timing case, see section 15.
- 10 Remove the flywheel and the flywheel housing, see operation 22A-3.
- 11 Remove the rear oil seal carrier, see operation 14A-3.
- 12 Remove the lubricating oil suction pipe and strainer and the lubricating oil pump, see section 19.
- 13 Remove the big end bearing caps (A) from the connecting rods. Keep the shell-bearings and their shell-bearing caps together.

Continued

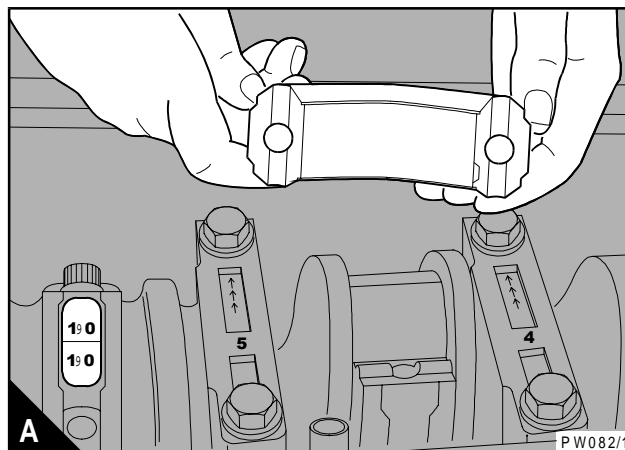

14A

- 14 Carefully push the pistons into their bores (A).
- 15 Ensure that the tops of the main bearing caps are stamped with their relevant position number (B).
- 16 Remove the main bearing caps and the lower shell-bearings. Keep the bearings with their relevant bearing caps.
- 17 Lift out the crankshaft (C).
- 18 Remove the upper shell-bearings (D) and keep each bearing with its relevant lower shell-bearing and bearing cap.

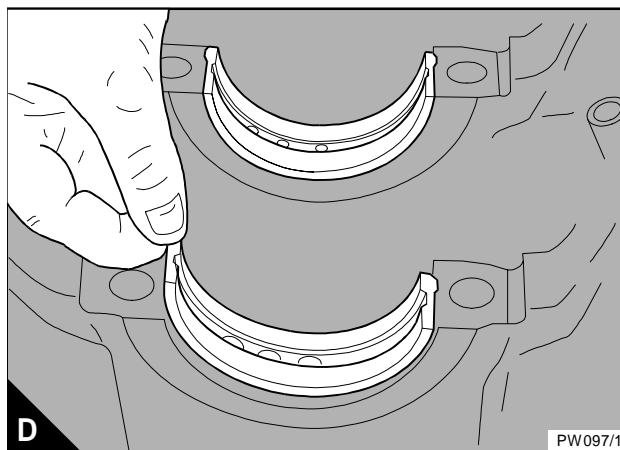
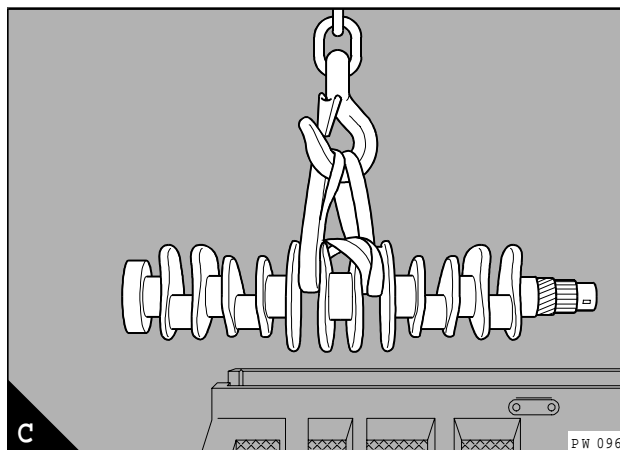
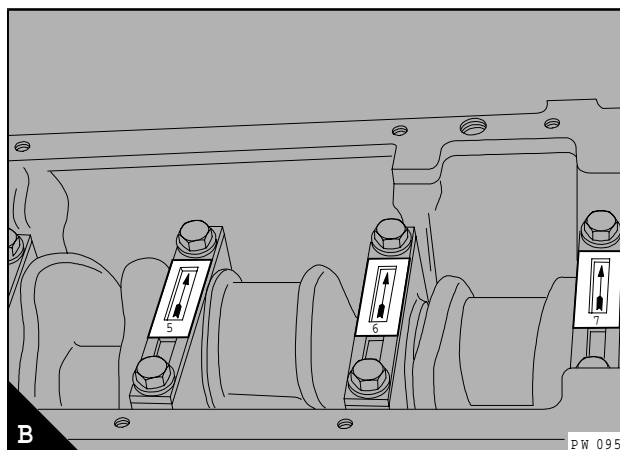
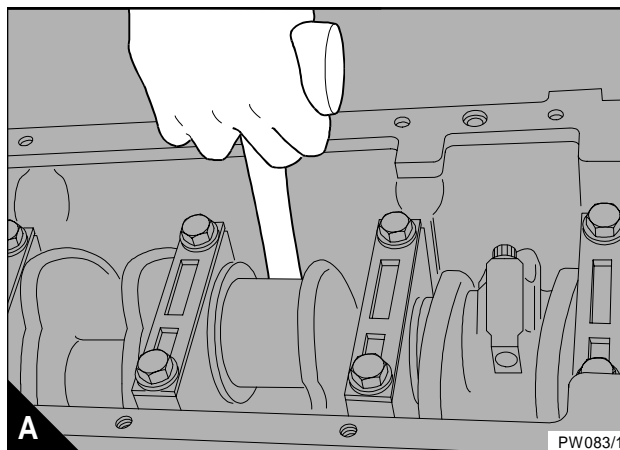

To fit

- 1 Ensure that all lubricating oil passages are clean and free from restriction.
- 2 Clean the main bearing housings and the upper shell-bearings.
- 3 Fit the upper shell-bearings (A2) with the location tags (A3) fitted correctly in their recesses.
- 4 Ensure that the large lubricating oil hole (A1) in the bearing is toward the camshaft side of the engine.
- 5 Lubricate the bearings with clean engine lubricating oil.
- 6 Ensure that the main journals of the crankshaft are clean.
- 7 Put the crankshaft in position on the upper shell-bearings.
- 8 Clean the bearing caps and the lower shell-bearings.
- 9 Fit the bearings to the caps with the location tags fitted correctly in their recesses (B).
- 10 Lubricate the bearings with clean engine lubricating oil.
- 11 Fit the bearing caps numbers 1 to 6 in their correct positions, as shown by the position number stamped on the top of the cap .

Caution: *Ensure that the arrows (B) stamped on the bearing caps are facing toward the camshaft side of the engine.*

- 12 Clean and inspect the setscrews for the main bearings. If the setscrews are damaged, fit new setscrews.
- 13 Lightly lubricate the setscrews with clean engine lubricating oil.
- 14 Fit the setscrews for the main bearing caps numbers 1 to 6, and tighten the setscrews gradually and evenly to the specific torques shown in section 11.

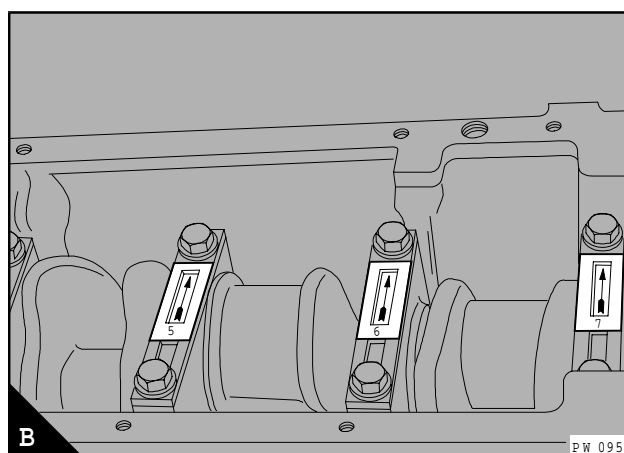
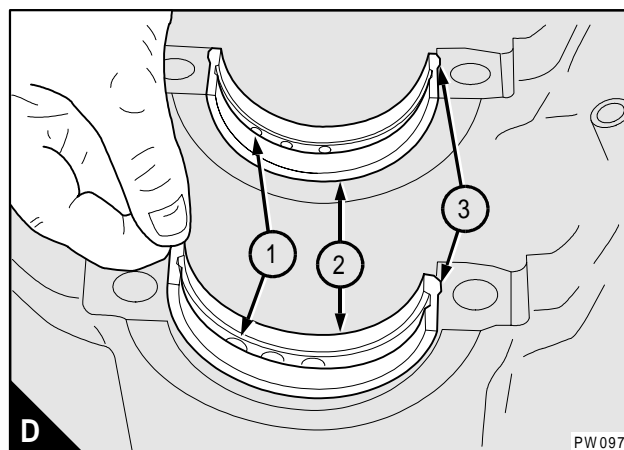

Continued

14A

15 Fit the bearing cap number 7 in position on the rear main journal (A).

Caution: *Ensure that the arrow stamped on the bearing cap is facing toward the camshaft side of the engine.*

16 To centre the thrust bearing, move the crankshaft to the front or to the back with a suitable lever.

17 Fit the setscrews to the main bearing cap number 7 and tighten the setscrews gradually and evenly to the specific torques shown in section 11.

18 Rotate the crankshaft two turns to ensure free movement.

19 Check the crankshaft end-float, [see operation 14A-8](#).

20 Fit the piston and connecting rod assemblies, [see operation 13A-3](#).

21 Fit the lubricating oil suction pipe and strainer, [see operation 19A-9](#).

22 Fit the rear oil seal housing, [see operation 14A-3](#).

23 Fit the lubricating oil sump, [see operation 19A-8](#).

24 Fit the flywheel and the flywheel housing, see section 22.

25 Fit the timing gears and the timing case, see section 15.

26 Fit the compressor and its drive assembly, see section 24.

27 Fit the high-pressure pump, see section 19B.

28 Fit the alternator and its mounting bracket, see section 23.

29 Fit the lubricating oil pump, [see operation 19A-8](#).

30 Fit the pulley/ damper assembly, [see operation 14A-1](#).

31 Fit the fan, the drive belt, the fan drive pulley and housing and the coolant pump, see section 21.

32 After the engine has been installed, fill the lubricating oil sump to the correct level with an approved oil.

33 Fill the cooling system.

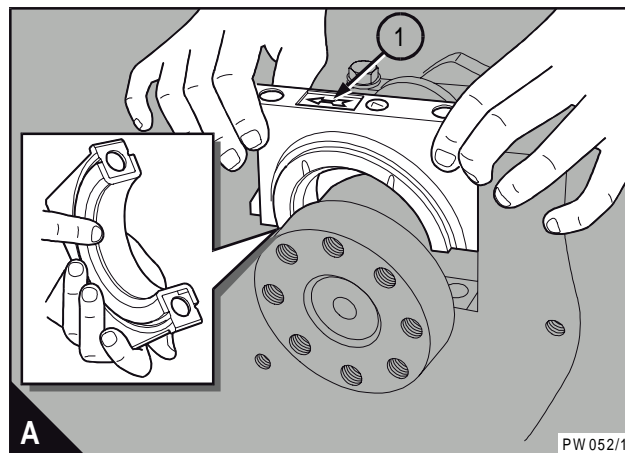

To inspect**14A-6**

Check the crankshaft for wear and other damage. The maximum permissible wear and ovality on the crankshaft journals is 0,05 mm (0.002 in). The maximum permissible wear and ovality on the crank pins is 0,0075 mm (0.00025 in).

The main journals and the crank pins of standard size crankshafts can be machined to 0,25 mm (0.010 in), 0,50 mm (0.020 in) or 0,75 mm (0.030 in) undersize on diameter, see data and dimensions. Special undersize bearings are available.

14A

Crankshaft gear

To renew

14A-7

Warning! Use suitable gloves to protect the hands from heat.

Caution: If the crankshaft gear is to be renewed, the drive spline for the oil pump has to be renewed also.

1 Remove the crankshaft, see operation 14A-5.

2 Put a suitable support (A3) under the crankshaft nose.

Caution: Do not scratch or damage the crankshaft with the chisel or the hammer. If the crankshaft is scratched or damaged, it will have to be reground or renewed.

3 Use a hammer and chisel to break the drive spline (A2) for the oil pump, and to break the crankshaft gear (A1).

4 Remove the drive spline for the oil pump, and remove the crankshaft gear.

5 Clean the crankshaft nose.

Caution: Do not fit a cold crankshaft gear, it will be damaged.

6 Heat a new crankshaft gear to 370-395 °F (188-202 °C)

7 Press the crankshaft gear (B2) onto the crankshaft (B4). Ensure that the locating pin (B1) engages in the crankshaft gear.

Caution: Do not fit a cold drive spline, it will be damaged.

8 Heat a new drive spline for the lubricating oil pump to 370-395 °F (188-202 °C).

9 Press the drive spline (B3) onto the crankshaft.

10 Fit the crankshaft, see operation 14A-5.

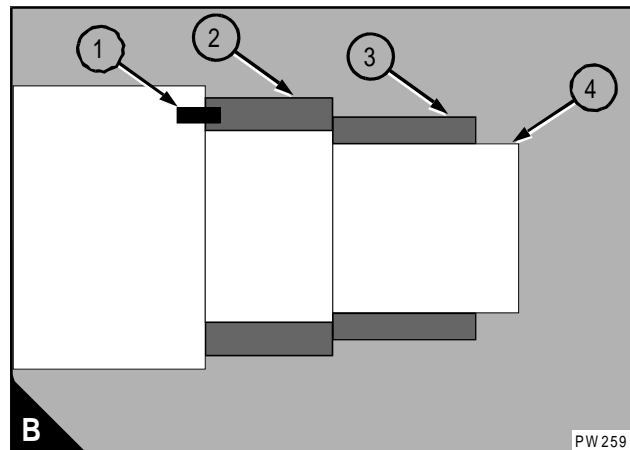
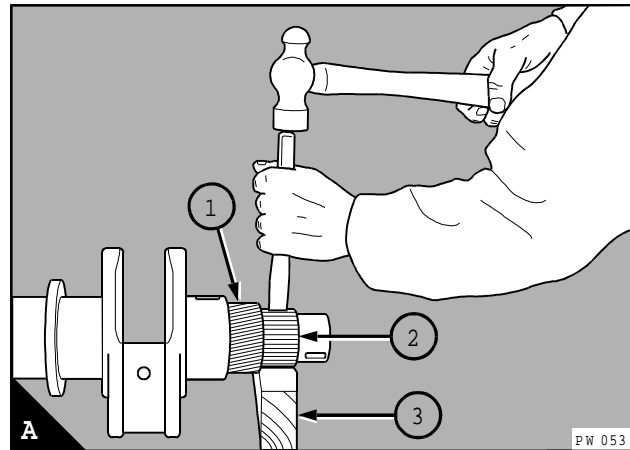

Thrust bearing

The axial movement of the crankshaft is controlled by a thrust bearing (A1) in the rear (number 7) main bearing cap. The end-float can be checked with a dial test indicator on one end of the crankshaft.

To check crankshaft end-float **14A-8**

- 1 Put a dial test indicator (B2) against the face of the crankshaft flange (B3).
- 2 Use a lever (B1) to move the crankshaft fully toward the front of the engine and set the indicator to zero.
- 3 Use a lever to move the crankshaft fully toward the rear of the engine and note the indicator reading.
- 4 Renew the thrust bearing if the end-float is more than the tolerance given in data and dimensions at the end of this section.

To remove and to fit **14A-9**

To remove

- 1 Drain the lubricating oil.
- 2 Remove the lubricating oil sump, [see operation 19A-8](#).
- 3 Release the setscrews of the rear main bearing and remove the main bearing cap (A) complete with the lower half of the thrust bearing (A1).
- 4 Push one end of the upper half of the thrust bearing with a suitable tool made of a soft material to slide the bearing out. Where necessary, move the crankshaft to the front or to the rear to loosen a tight bearing.

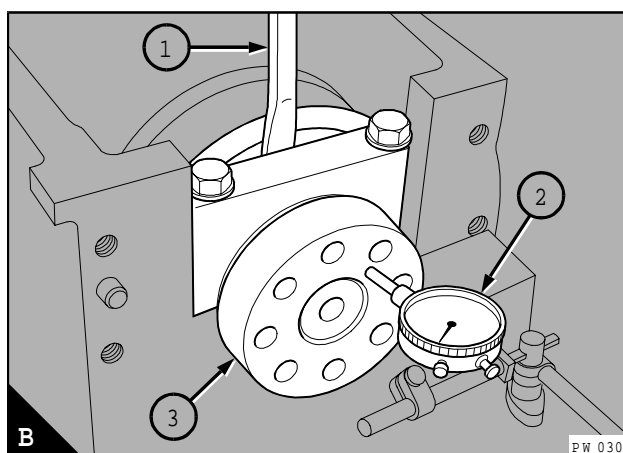
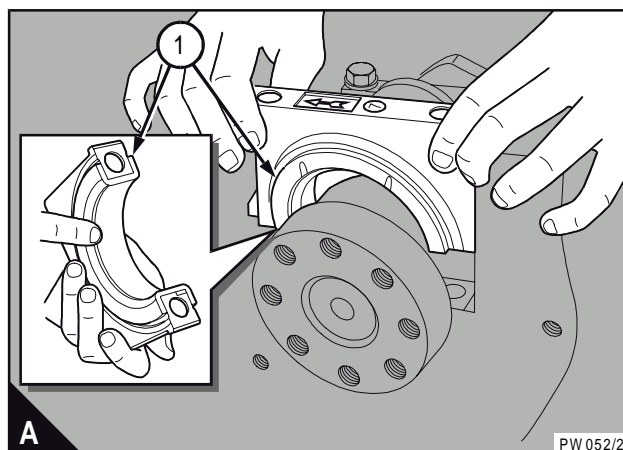

14A

To fit

- 1 Lubricate the thrust bearing with clean engine lubricating oil.
- 2 Slide the upper-half of the thrust bearing into position with the location tag fitted correctly in its recess. Ensure that the large lubricating oil hole in the bearing is toward the camshaft side of the engine.
- 3 Fit the lower-half of the thrust bearing (A1) to the main bearing cap (A3) with the location tag (A4) in its recess. Ensure that the bearing is fitted correctly in the cap and that the bearing and the crankshaft journal are clean. Lubricate the bearing with clean engine lubricating oil.
- 4 Put the bearing cap in position. Ensure that the arrow (A2) stamped on the bearing cap is toward the camshaft side of the engine.
- 5 Clean and inspect the setscrews for the main bearing. If the setscrews are damaged, fit new setscrews.
- 6 Lightly lubricate the setscrews with clean engine lubricating oil.
- 7 Fit the setscrews to the main bearing cap, and tighten the setscrews gradually and evenly to the specific torques shown in section 11B.
- 8 Rotate the crankshaft two turns to ensure free movement.
- 9 Check the crankshaft end-float, [see operation 14A-8](#).
- 10 Fit the lubricating oil sump, [see operation 19A-8](#).
- 11 After the engine has been installed, fill the lubricating oil sump to the correct level with an approved oil.
- 12 Fill the cooling system.

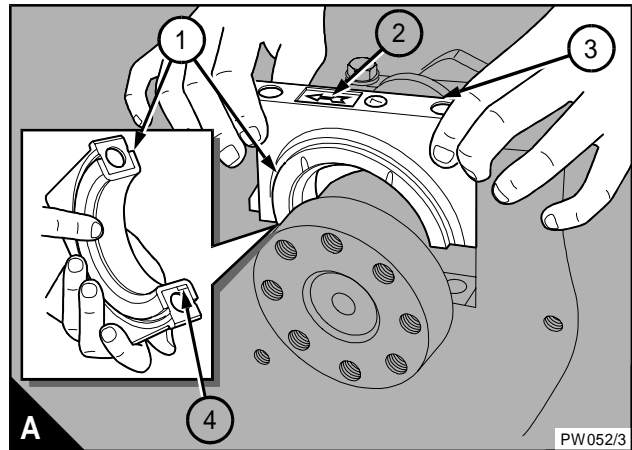

Main bearings

To remove and to fit

14A-10

To remove

- 1 Drain the lubricating oil and remove the sump, [see operation 19A-8](#).
- 2 Remove all necessary components to get access to the specific bearing cap.
- 3 Release the setscrews of the bearing cap and remove the bearing cap (A).
- 4 Remove the lower shell-bearing from the cap.
- 5 With a suitable tool, push the upper shell-bearing from the side opposite to the location tag to remove the bearing tag from its recess in the bearing housing.
- 6 Carefully rotate the crankshaft to release the bearing from its housing.
- 7 Keep the halves of the shell-bearing in their relevant positions.

To fit

- 1 Clean the upper shell-bearing and lubricate the bearing surface with clean engine lubricating oil.
- 2 Fit the plain end of the upper shell-bearing between the crankshaft journal and the side of the bearing housing which has the recess for the location tag. Slide the bearing into its housing until the tag on the bearing is fitted correctly in its recess in the housing.
- 3 Clean the lower shell-bearing and the cap, lubricate the bearing surface with clean engine lubricating oil.
- 4 Fit the bearing into the cap with the tag of the bearing fitted correctly in the recess in the cap.
- 5 Fit the bearing cap with the location tags of both shell-bearings on the same side.
- 6 Inspect the setscrews for damage and for distortion and renew them if necessary. Lightly lubricate the threads and the thrust faces of the setscrew with clean engine lubricating oil.
- 7 Fit the setscrews, and tighten the setscrews gradually and evenly to the specific torques shown in section 11B.
- 8 Ensure that the crankshaft rotates freely. If the thrust bearing (number 7) has been removed and fitted, check the crankshaft end-float, [see operation 14A-8](#).
- 9 Fit all the components which were removed for access to the main bearing caps.
- 10 Fit the lubricating oil sump, [see operation 19A-8](#).
- 11 Fill the sump to the correct level with an approved lubricating oil.

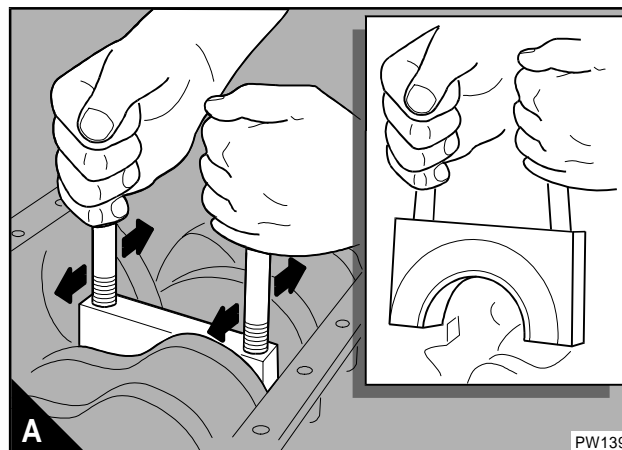

14A

To inspect

14A-11

Inspect the bearings for wear and for other damage. If a bearing is worn or damaged, renew both shell-bearings and check the condition of the other bearings.

If the thrust bearing (number 7) has been removed and fitted, check the crankshaft end-float, [see operation 14A-8](#).

Data and dimensions

Note: This information is given as a guide for personnel engaged on engine overhauls. The dimensions which are shown are those which are mainly used in the factory.

Crankshaft

Number of main bearings	7
Thrust bearing position	Rear main (number 7)
Crankshaft end-float	0,152/0,305 mm (0.006/0.012 in)
Maximum permissible end-float.....	0,508 mm (0.020 in)
Crankshaft flange diameter	141 mm (5.550 in)
Crankshaft gear backlash.....	0,076/0,406 mm (0.003/0.016 in)
Rear oil seal run-out (Maximum)	0,076 mm (0.003 in)
Flywheel run-out (Maximum)	0,05 mm (0.002 in)

Main bearing journals

Width (Except thrust bearing journal)	33 +/- 0,015 mm (1.286 +/- 0.0006 in)
Width of thrust bearing journal.....	34,4 +/- 0,254 mm (1.355 +/- 0.0100 in)
Ovality (Maximum).....	0,05 mm (0.002 in)
Thrust face, out of alignment (Maximum)	0,025 mm (0.001 in)
Taper (Maximum)	0,0711 mm (0.0028 in)
Fillet radius	1,27/5,72 mm (0.050/0.225 in)
Clearance, bearing to crankshaft.....	0,046/0,127 mm (0.0018/0.0050 in)
Diameter of main journals:	
- New	89,8 +/- 0,0152 mm (3.535 +/- 0.0006 in)
- 0.010 in undersize	89,5 +/- 0,0152 mm (3.525 +/- 0.0006 in)
- 0.020 in undersize	89,3 +/- 0,0152 mm (3.515 +/- 0.0006 in)
- 0.030 in undersize	89,0 +/- 0,0152 mm (3.505 +/- 0.0006 in)

Crank pins

Width	35,2 mm (1.385 in)
Ovality (Maximum).....	0,0064mm (0.00025 in)
Taper (Maximum)	0,0069 mm (0.00027 in)
Fillet radii	1,27/5,72 mm (0.050/0.225 in)
Finish.....	Polish to 5/20 microns
Hardness limit.....	50 RC
Diameter of crank pins:	
- New	80,0 +/- 0,0152 mm (3.1500 +/- 0.0006 in)
- 0.010 in undersize	79,7 +/- 0,0152 mm (3.1400 +/- 0.0006 in)
- 0.020 in undersize	79,5 +/- 0,0152 mm (3.1300 +/- 0.0006 in)
- 0.030 in undersize	79,2 +/- 0,0152 mm (3.1200 +/- 0.0006 in)

Pulley / damper assembly

- run-out of the mounting face (Maximum)	0,013 mm (0.0005 in)
- maximum permissible tolerance for the component alignment marks	1,5 mm (0.06 in)

Note:

- Induction hardened crankshafts need not be hardened after they have been machined undersize.
- Check the crankshaft for cracks before and after it is ground. Demagnetise the crankshaft after it has been checked for cracks.
- After the crankshaft has been machined remove any sharp corners from the lubricating oil holes.

15A

Timing case and drive assembly

General description

The aluminium timing case, which is a two piece casting, contains the drive gears. There are two idler gears: the lower idler gear (A4) and the upper idler gear (A2). The lower idler gear is driven by the crankshaft gear (A5) and drives the upper idler gear and, if fitted, the compressor. The upper idler gear drives the camshaft gear (A1) and the gear (A3) for the high-pressure pump. All of the gears have timing marks except for the gear for the high-pressure pump. There is a spline on the crankshaft nose to drive the lubricating oil pump. A power take-off can be fitted to the right hand side of the engine. If one is fitted, it is driven by the lower idler gear.

The idler gears are mounted on taper roller bearings.

The camshaft gear rotates at half engine speed.

The timing case assembly has channels and ports for the coolant and for the lubricating oil. This reduces the need for external pipes and improves engine reliability.

The camshaft rotates in four bushes that can be renewed.

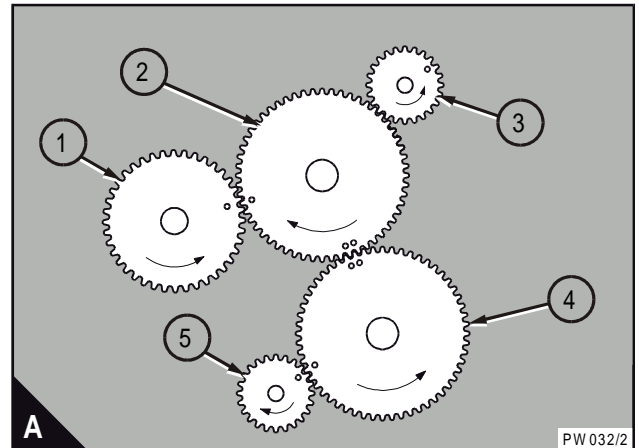

15A

Components of the timing case (A).

- 1 Timing case cover
- 2 Pressure relief valve
- 3 Dowels
- 4 Timing case backplate
- 5 Joint
- 6 'O' ring
- 7 Joints
- 8 'O' rings
- 9 Timing indicator

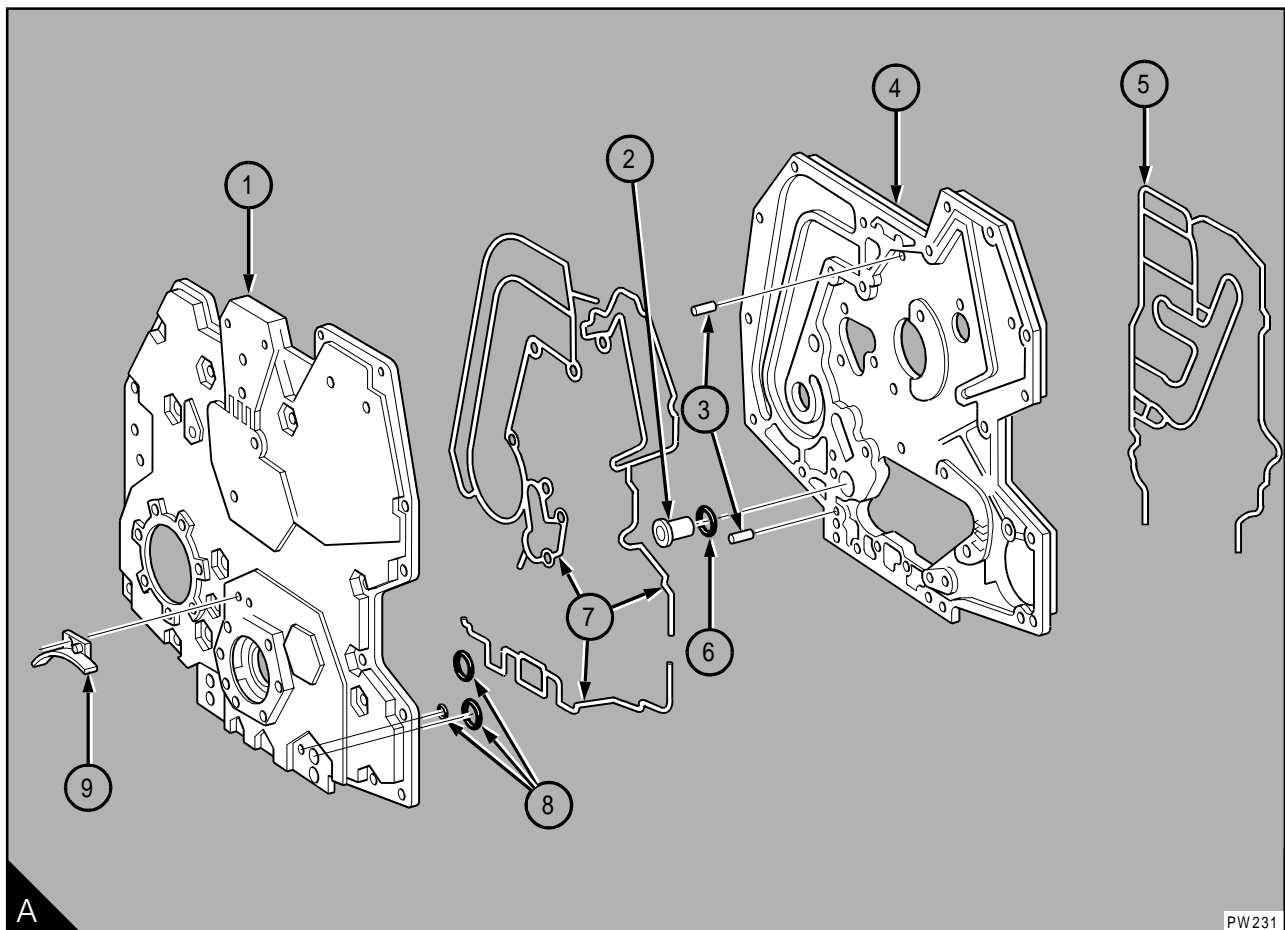

Timing case cover

To remove and to fit

15A-1

to remove

- 1 Drain the engine lubricating oil.
- 2 Drain the cooling system.
- 3 Remove the fan, fan belt, drive pulley and fan mounting, see section 21.
- 4 Remove the fan belt tensioner.
- 5 Remove the alternator and its mounting bracket.
- 6 Remove the pulley / damper assembly, [see operation 14A-1](#).
- 7 Remove the water pump pulley and the water pump, [see operation 21A-4](#).
- 8 Remove the lubricating oil pump, [see operation 19A-10](#).
- 9 Release the nuts, bolts and setscrews of the timing case cover and remove the timing case cover.
- 10 Remove and discard the 'O' rings (15A.02/A8) and joints (15A.02/A7).

To fit

- 1 Clean the faces of the timing case cover (15A.02/A1).
- 2 Put new joints and 'O' rings on the cover and put the cover in position on its dowels (15A.02/A3). The dowels are at the 1 o'clock and the 7 o'clock positions.
- 3 Loosely fit two opposite setscrews to hold the cover in place.
- 4 Fit the remainder of the fasteners and tighten all of the cover fasteners to 26 Nm (19 lbf ft) 2,7 kgf m.
- 5 Fit the water pump and the water pump pulley, [see operation 21A-4](#).
- 6 Fit the lubricating oil pump, [see operation 19A-10](#).
- 7 Fit the pulley / damper assembly, [see operation 14A-1](#).
- 8 Fit the alternator mounting bracket and the alternator, [see operation 23A-1](#).
- 9 Fit the fan belt tensioner.
- 10 Fit the fan mounting, drive pulley, fan belt and fan, see section 21A.
- 11 Fill the lubricating oil sump to the correct level with an approved lubricating oil.
- 12 Fill the cooling system to the correct level.

15A

Idler gears

To remove and to fit

15A-2

Note: The setscrew for the upper idler gear (A1) enters the water jacket. To prevent leakage of coolant, the setscrew is supplied with a sealant on its thread.

Caution: The setscrew for the upper idler gear must be renewed when it is removed from the engine.

To remove

- 1 Set number one cylinder to TDC on the compression stroke, [see operation 17A-1](#).
- 2 Drain the cooling system.
- 3 Remove the timing case cover, [see operation 15A-1](#).
- 4 Measure and record the backlash of the upper idler gear (B). Measure and record the backlash of the lower idler gear (C). Compare the results with the data and dimensions. Renew any gear that is out of tolerance.
- 5 Remove and discard the setscrew of the upper idler gear. Remove the upper idler gear.
- 6 Remove the setscrew of the lower idler gear and remove the lower idler gear (A2).

Caution: If the crankshaft is rotated with one or both of the idler gears removed, the timing of the engine will be incorrect.

- 7 Inspect the gears and their bearings for wear and other damage and renew them as necessary. The gear and their taper roller bearings must be renewed as an assembly.

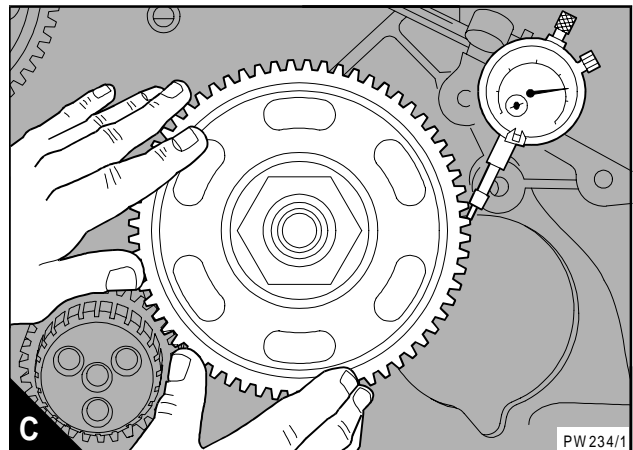
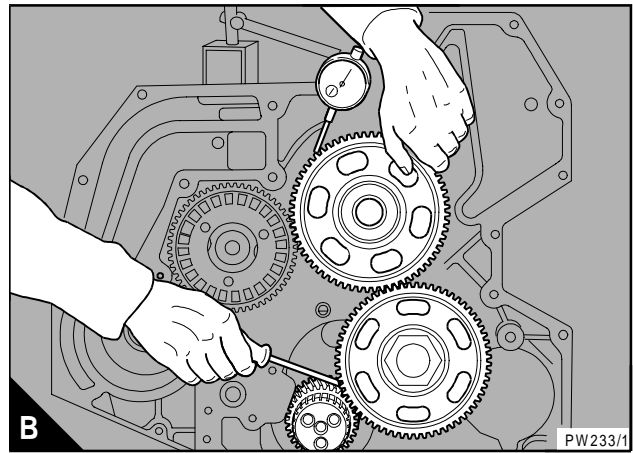
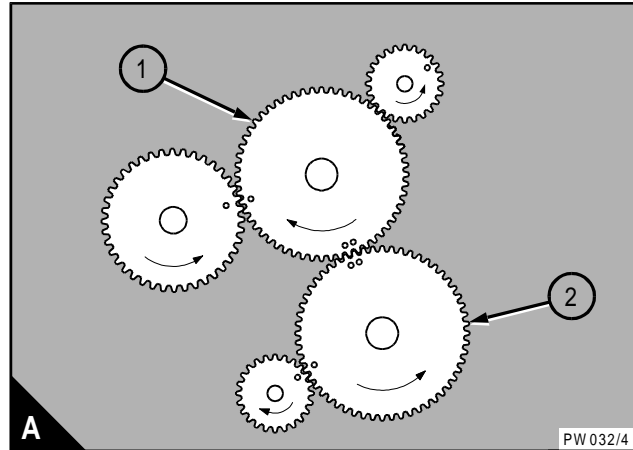

To fit

Caution: Ensure that the piston of number 1 cylinder is set to TDC.

- 1 Lubricate the bearings of the idler gears with clean engine lubricating oil.
 - 2 Lightly lubricate the threads and shoulder of the setscrew for the lower idler gear with clean engine lubricating oil.
 - 3 Put the lower idler gear (A4) in position and in mesh with the crankshaft gear (A5) so that the timing marks align (A).
 - 4 Fit and tighten the setscrew to 637 Nm (470 lbf ft) 65,6 kgf m.
 - 5 Ensure that the thread in the cylinder block for the setscrew of the upper idler gear is clean and dry.
- Note:** The setscrew for the upper idler gear (A2) is supplied with a sealant on its thread. Do not add more sealant to the thread of the setscrew. Do not put lubricating oil on the thread of the setscrew.
- 6 Put the upper idler gear in position and in mesh with the camshaft gear (A1), the lower idler gear and the high-pressure pump gear (A3). Ensure that the timing marks (A) align on the upper idler gear, the camshaft gear, the crankshaft gear and the lower idler gear.
- Note:** There are no timing marks on the high-pressure pump gear.
- 7 Fit and tighten the new setscrew for the upper idler gear to 325 Nm (240 lbf ft) 33,2 kgf m.
 - 8 Check that the backlash of the gears is still within tolerance. Renew any gear that is out of tolerance.
 - 9 Fit the timing case cover, see operation 15A-1.
 - 10 Fill the cooling system to the correct level.

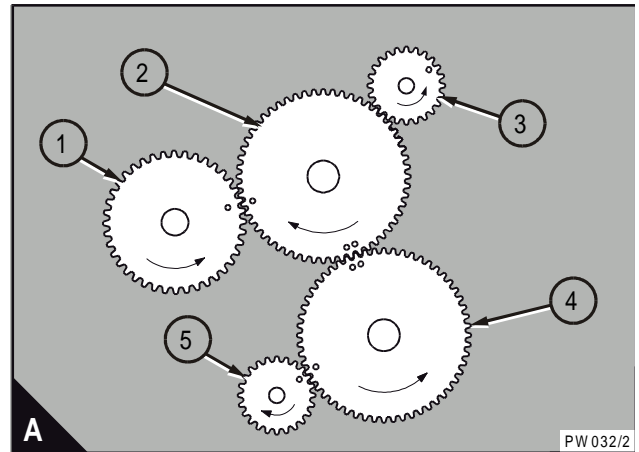

Timing case backplate

To remove and to fit

15A-3

To remove

- 1 Remove the timing case cover, [see operation 15A-1](#).
- 2 Remove the high-pressure pump, [see operation 19B-2](#).
- 3 Remove the power steering pump, the compressor and their mounting brackets, if these auxiliaries are fitted, [see section 24](#).
- 4 Remove and discard the coolant filter.
- 5 Remove the idler gears, [see operation 15A-2](#).
- 6 Remove the oil pressure relief valve (15A.03/A2) from the crankcase.
- 7 Remove the rocker assembly, [see operation 12A-3](#). Remove all the push rods and note their relative positions.
- 8 Remove the cylinder head, [see operation 12A-6](#).
- 9 Remove the tappets from their bores and note their relative positions.
- 10 Remove the camshaft, [see operation 15A-4](#).
- 11 Remove the setscrews and remove the timing case backplate. The backplate is located on two dowels (15A.03/A3).
- 12 Remove the timing case backplate (15A.03/A4).

To fit

- 1 Clean and inspect all components for wear or damage. Inspect the timing case for cracks, especially around the channels for the engine fluids.
- 2 Fit a new joint (15A.03/A5) to the backplate.
- 3 Engage the backplate dowels (15A.03/A3) and push the backplate onto the engine.
- 4 Lightly lubricate the threads and shoulders of the setscrews for the backplate with clean engine lubricating oil.
- 5 Fit and tighten the setscrews to 26 Nm (19 lbf ft) 2,6 kgf m.
- 6 Fit the camshaft, [see operation 15A-4](#).
- 7 Fit the tappets into their original bores.
- 8 Fit the cylinder head, [see operation 12A-6](#).
- 9 Fit the oil pressure relief valve together with its 'O' ring (15A.03/A6).

Continued

- 10** Fit the idler gears, [see operation 15A-2](#).
- 11** Fit a new coolant filter.
- 12** Fit the power steering pump, the compressor and their mounting brackets, if removed earlier, see section 24.
- 13** Fit the high-pressure pump, [see operation 19B-2](#).
- 14** Fit the timing case cover, [see operation 15A-1](#).
- 15** Fill the cooling system to the correct level.
- 16** Fill the lubricating system to the correct level with an approved oil.

15A

Camshaft and tappets

Caution: The camshaft gear is an interference fit on the camshaft and must not be removed unless it is to be renewed. A new gear must be heated to 206 °C (400 °F) to fit onto the camshaft.

Note:

- The four camshaft bushes can be renewed.
- An engine timing plate is fitted to the camshaft gear.

To remove and to fit

15A-4

To remove

- 1 Set number one cylinder to TDC on the compression stroke, see operation 17A-1.
- 2 Drain the engine lubricating oil.
- 3 Drain the cooling system.
- 4 Remove the timing case cove, see operation 15A-1.
- 5 Remove the cylinder head, see operation 12A-6.
- 6 Remove the tappets (A) from their bores and note their relative positions.
- 7 Measure the backlash of the camshaft gear (B) and compare the reading with data and dimensions. If the backlash is incorrect, renew the gear.
- 8 Remove the cap screws (C2) which retain the timing plate (C3).
- 9 Remove the timing plate from its dowels (C1).
- 10 Remove the setscrews from the camshaft thrust plate, access to the setscrews is through the two holes in the gear face (D).
- 11 Carefully remove the camshaft.

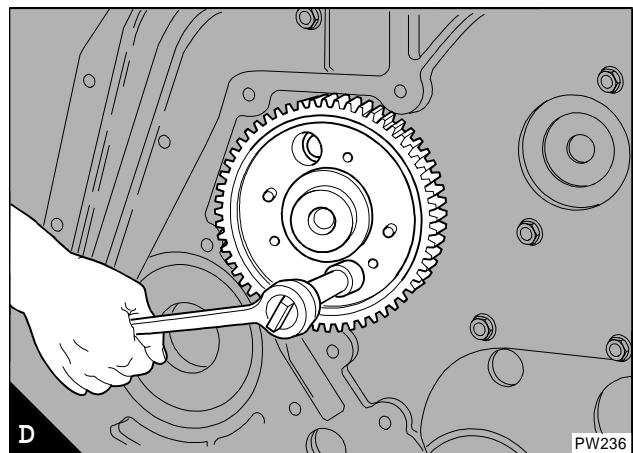
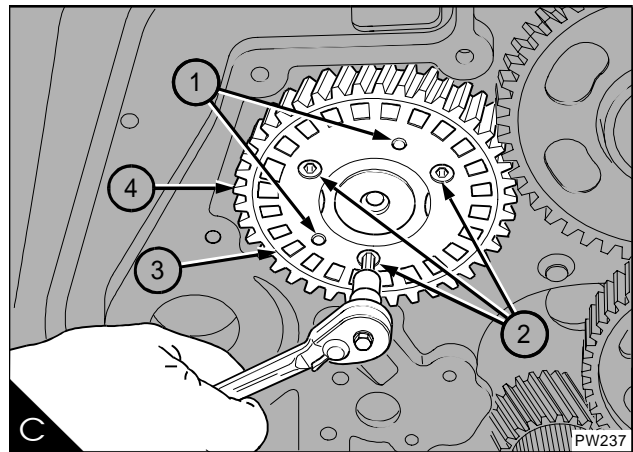
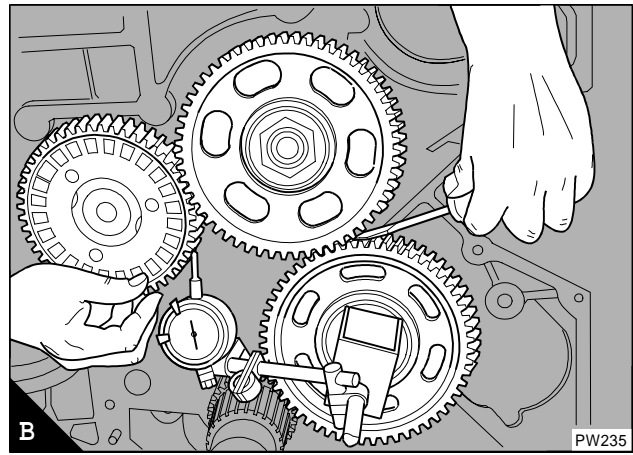
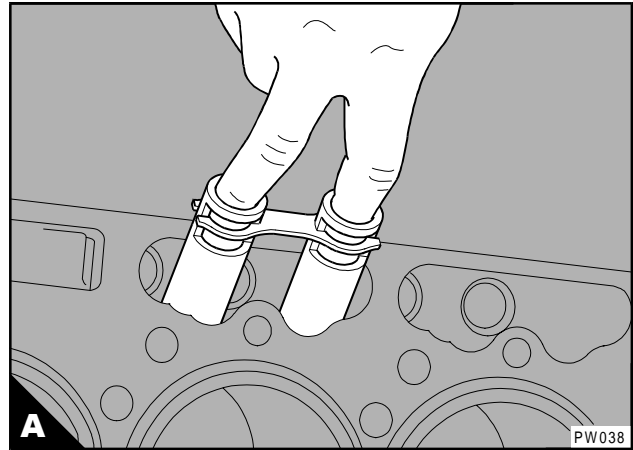

To fit

- 1 Ensure that all components are clean and are lubricated with clean engine lubricating oil.
- 2 Carefully fit the camshaft. Ensure that the timing marks on the upper idler gear and the camshaft gear align. If a new gear is fitted, measure the backlash (15A.09/B).
- 3 Engage the timing plate dowels (C1) and push the timing plate (C3) onto the camshaft gear (C4), fit and tighten the cap screws (C2) to 7 Nm (5 lbf ft) 0,7 kgf m.
- 4 Fit the tappets (A) into their original bores.
- 5 Fit the cylinder head, see operation 12A-05.
- 6 Fit the timing case cover, see operation 15A-01.
- 7 Fill the cooling system to the correct level.
- 8 Fill the lubricating system to the correct level with an approved oil

To inspect**15A-5**

With the camshaft removed from the engine, measure the camshaft lobes at line AA and at line BB in figure (B) and record the readings. Measure the tappets, the thrust plate and the camshaft bushes. Compare all the readings with data and dimensions. Renew damaged or worn components as necessary.

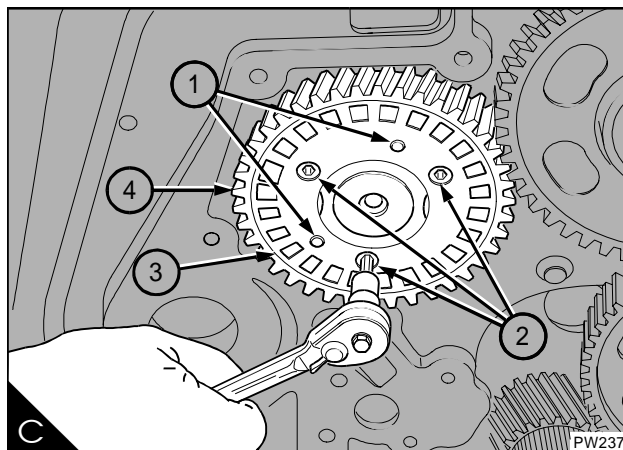
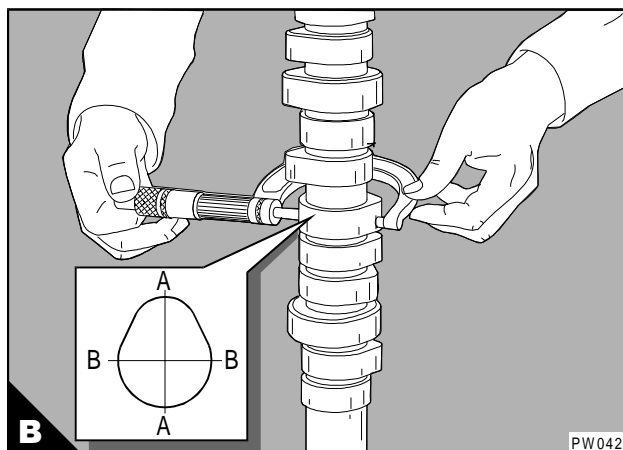
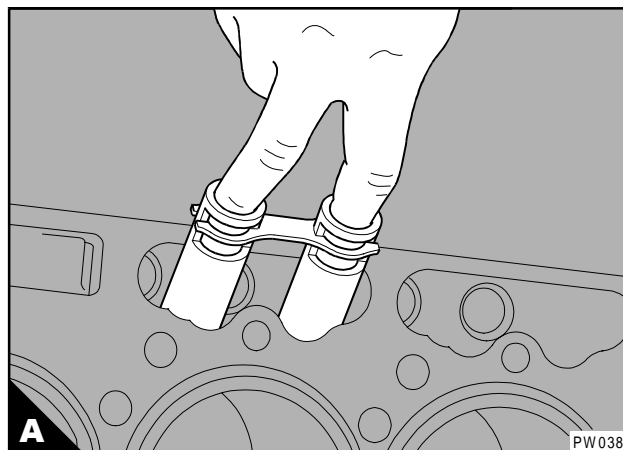

Camshaft bushes

The four camshaft bushes have the same internal diameter, but all of the external diameters are different, see data and dimensions.

The bushes must be removed and fitted in the correct sequence, they shall be referred to in this manual as number 1 bush, number 2 bush, number 3 bush and number 4 bush. Number 1 bush is at the front of the engine.

The internal diameters of the bushes are the same but the external diameters are different for each bush, see data and dimensions. The rear bush is removed toward the rear of the engine, the other three bushes are removed toward the front of the engine.

To renew

15A-6

Special tools:

Camshaft bush remover and replacer 21825995

1 Remove the camshaft, see operation 15A-4.

Note: Use Tool 21825995 to remove and to fit the bushes.

2 To remove number 4 bush (A4), pull it toward the rear of the engine.

3 To remove the other three bushes, pull them toward the front of the engine in the sequence: number 1 bush (A1), number 2 bush (A2) then the number 3 bush (A3).

4 Clean and inspect the bush housings for damage. Ensure that all the lubricating oil holes are free of debris.

5 lubricate the bushes and the bush housings with clean engine lubricating oil.

Caution: Ensure that the lubricating oil holes of each bush is on the same side, and is aligned with the lubricating oil holes in the crankcase.

6 Fit number 4 bush (B); put it into position from the rear of the engine and then pull it toward the front of the engine.

7 Fit the other three bushes (C) in the sequence: number 3 bush, number 2 bush then the number 1 bush. Put each bush into position from the front of the engine and then pull it toward the rear of the engine.

8 Fit the camshaft, see operation 15A-4.

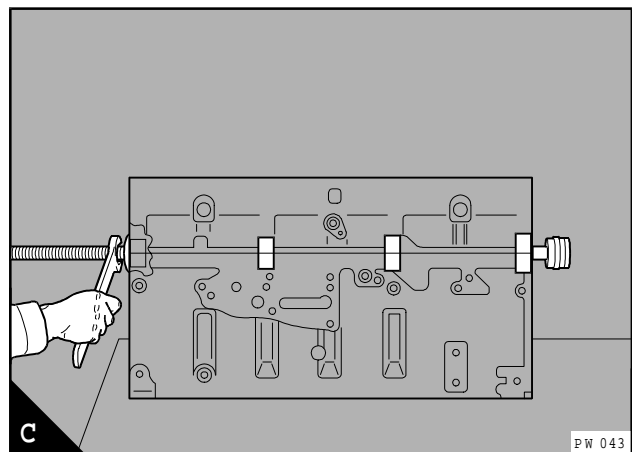
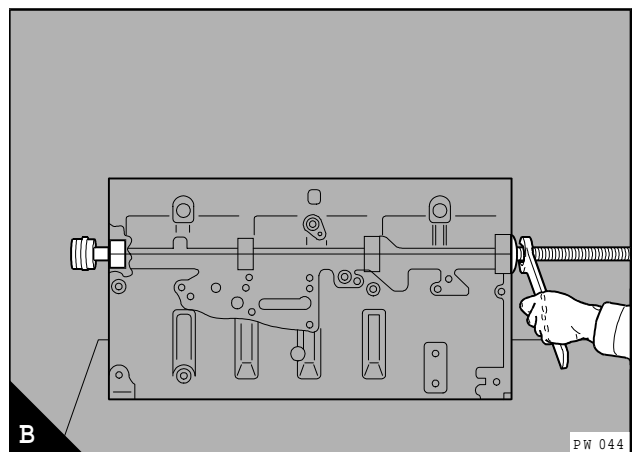
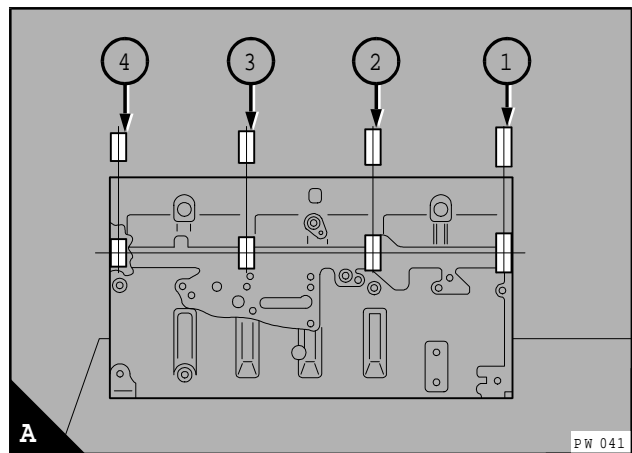

Data and dimensions

Note: This information is given as a guide for personnel engaged on engine overhauls. The dimensions which are shown are those which are mainly used in the factory. The information applies to all engines, unless an engine type code is shown.

Camshaft

Diameter of all the journals	57,948/57,976 mm (2.2814/2.2825 in)
Clearance of all journals	0,051/0,178 mm (0.002/0.007 in)
Clearance service limit (maximum)	0,20 mm (0.008 in)
Cam lift:	
- Inlet.....	8,070 mm (0.3177 in)
- Exhaust	7,369 mm (0.2901 in)
Maximum permissible wear on cam lobes.....	0,51 mm (0.002 in)
End float	0,13/0,33 mm (0.005/0.013 in)
Thickness of thrust plate.....	6,96/7,01 mm (0.274/0.276 in)

Camshaft bushes

Inside diameter of all the camshaft bushes (fitted)	58,026/58,115 mm (2.2845/2.2880 in)
Number 1:	
- Outside diameter	63,6270/63,6651 mm (2.5050/2.5065 in)
- Width	25,4 mm (1.00 in)
- Parent bore diameter.....	63,5127/63,5508 mm (2.5005/2.5020 in)
Number 2:	
- Outside diameter	63,1190/63,1571 mm (2.4850/2.4865 in)
- Width	17,5/18,0 mm (0.69/0.71 in)
- Parent bore diameter.....	63,0047/63,0428 mm (2.4805/2.4820 in)
Number 3:	
- Outside diameter	62,6110/62,6491 mm (2.4650/2.4665 in)
- Width	17,5/18,0 mm (0.69/0.71 in)
- Parent bore diameter.....	62,4967/62,5348 mm (2.4605/2.4620 in)
Number 4:	
- Outside diameter	62,1030/62,1411 mm (2.4450/2.4465 in)
- Width	16,8/18,8 mm (0.69/0.71 in)
- Parent bore diameter.....	61,9887/62,0268 mm (2.4405/2.4420 in)

Timing gears

Backlash:	
- Lower idler gear.....	0,356 mm (0.014 in)
- Compressor gear.....	0,508 mm (0.020 in)
- Upper idler gear.....	0,482 mm (0.019 in)
- high-pressure pump gear	0,482 mm (0.019 in)
- Camshaft gear.....	0,457 mm (0.018 in)

16A

Cylinder block assembly

General description

The cylinder block is made of cast iron and provides support for the wet cylinder liners which are also made of cast iron.

Four bushes are fitted to the cylinder block for the camshaft journals.

16A

Cylinder block

To dismantle and to assemble **16A-1**

To dismantle

- 1 Drain the cooling system
- 2 Drain the lubricating oil.
- 3 Remove the engine from the vehicle or machine.
- 4 Remove the starter motor, [see operation 23A-4](#).
- 5 Remove all auxiliary equipment, [see section 24](#).
- 6 Remove the flywheel and the flywheel housing, [see section 22](#).
- 7 Remove the cylinder head, [see operation 12A-6](#).
- 8 Remove the timing case cover, [see operation 15A-1](#).
- 9 Remove the timing case backplate, [see operation 15A-3](#).
- 10 Remove the lubricating oil sump, [see operation 19A-8](#).
- 11 Remove the pistons and connecting rods, [see operation 13A-3](#).
- 12 Remove the crankshaft, [see operation 14A-5](#).

To assemble

- 1 Clean thoroughly the cylinder block. Ensure that all the oil passages are clean and free of debris.
- 2 Fit the crankshaft and the rear oil seal assembly, [see section 14](#).
- 3 Fit the pistons and connecting rod assemblies, [see operation 13A-3](#).
- 4 Fit the lubricating oil sump, [see operation 19A-8](#).
- 5 Fit the flywheel housing and the flywheel, [see section 22](#).
- 6 Fit the timing case backplate, [see operation 15A-3](#).
- 7 Fit the timing case and the timing gears, [see section 15](#).
- 8 Fit the cylinder head, [see operation 12A-6](#).
- 9 Fit the starter motor, [see operation 23A-4](#).
- 10 Fit all the auxiliaries removed earlier, [see section 24](#).
- 11 Install the engine into the vehicle or machine.
- 12 Fill the cooling system to the correct level with a coolant of the correct specification, [see section 5 of the user's handbook](#).
- 13 Fill the lubricating oil system to the correct level with an approved lubricating oil.

To inspect

16A-2

- 1 Clean the passages for the coolant and for the engine lubricating oil.
- 2 Check the cylinder block for cracks and for other damage.
- 3 The top face of the cylinder block must not be machined as this will affect the protrusion of the liner flange and the piston height.
- 4 Check the camshaft bushes for wear, [see operation 15A-5](#).

Cylinder liner

To remove and to fit

16A-3

Special tools:

Cylinder liner retainer kit 21825959

Cylinder liner removal adaptor 21825956

Cylinder liner remover/replacer 21825543

To remove

- 1 Drain the cooling system
- 2 Drain the lubricating oil.
- 3 Remove the lubricating oil sump, [see operation 19A-8](#).
- 4 Remove the cylinder head, [see operation 12A-6](#).
- 5 Remove the pistons and connecting rods, [see operation 13A-3](#).
- 6 Rotate the crankshaft to allow access to the cylinder liner and to protect the crank pin.
- 7 Put the tool (A4) on the top face of the cylinder block and over the centre of the cylinder liner (A5). Ensure that the base of the tool is not on top of the flange of the next cylinder liner.
- 8 Put the bearing (A3) in the top of the tool with the face of the bearing to the bottom of the recess.
- 9 Fit the threaded rod (A1) through the bearing and the top of the tool until the handle (A2) is in the recess in the top of the bearing. In this position adjust the threaded rod until the end is below the bottom of the cylinder liner.
- 10 Fit the adaptor 21825956 (A6) onto the threaded rod and against the bottom of the cylinder liner.
- 11 Ensure that the two lugs on the top of the adaptor engage with the flats on the threaded rod.
- 12 Fit the washer and nut and tighten the nut onto the adaptor.
- 13 Lubricate the ratchet of the handle and the threaded rod with shell spirax or an equivalent oil. Operate the handle to pull the cylinder liner out of the top of the cylinder block.

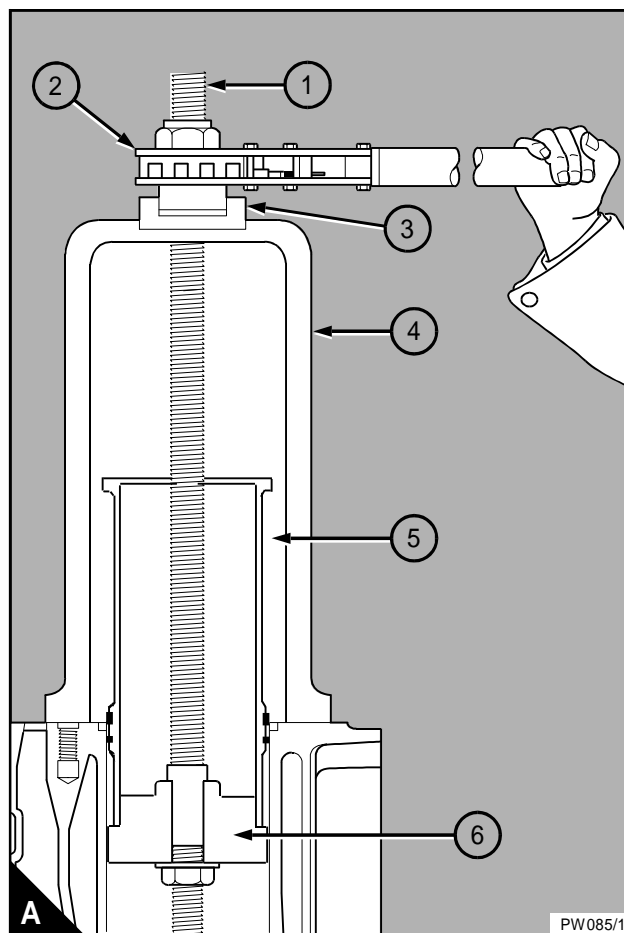

16A

To fit

If the original cylinder liner is to be fitted it must be rotated 90° from its original position to put the worn area away from the thrust face.

- 1 Clean thoroughly the parent bore and the cylinder liner. It is important that the recess for the flange of the cylinder liner is clean, and that the flange of the cylinder liner is also clean.
- 2 Fit new seals to the cylinder liner. Ensure that the seals are fitted correctly in their grooves.
- 3 Lightly lubricate the parent bore, the cylinder liner and the new seals with clean engine lubricating oil.
- 4 Engage the cylinder liner in the parent bore. Ensure that the cylinder liner is vertical and push the liner fully into the cylinder block by hand (B). Ensure that there is no distortion of the liner seals.
- 5 Fit the retainer kit 21825959, (A) for the cylinder liner. Tighten the three setscrews gradually and evenly to 55 Nm (40 lbf ft) 5,53 kgf m. Further tighten the three setscrews gradually and evenly to 110 Nm (80 lbf ft) 11,06 kgf m.
- 6 Measure the inside diameter of the cylinder liner, [see operation 16A-4](#).

Note: If the bore is too small this indicates that the liner seal has not seated correctly and has caused distortion of the liner. Remove the liner and fit it again until it is correct.

- 7 Measure the cylinder liner protrusion (A) to ensure that the liner is fitted correctly. Take one measurement between each of the three clamps of the retainer kit. Set the dial test indicator to zero on the top face of the cylinder block before each measurement. The correct protrusion of the cylinder liner is 0,05/0,13 mm (0.002/0.006 in).
- 8 Remove the retainer kit 21825959.
- 9 Fit the pistons and connecting rods, [see operation 13A-3](#).
- 10 Fit the cylinder head, [see operation 12A-6](#).
- 11 Fit the lubricating oil sump, [see operation 19A-8](#).
- 12 Fill the cooling system to the correct level.
- 13 Fill the lubricating oil system to the correct level with an approved oil.

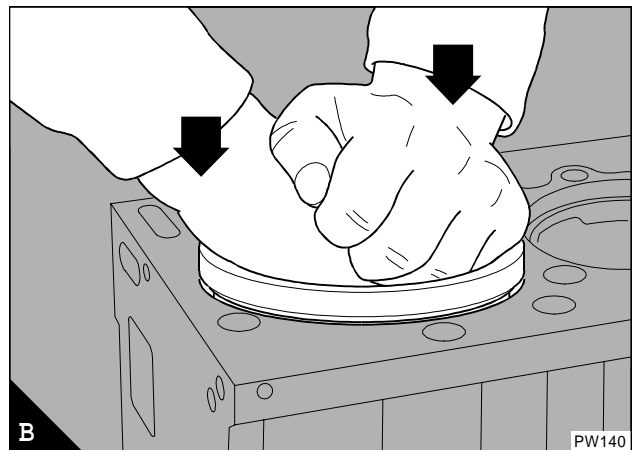
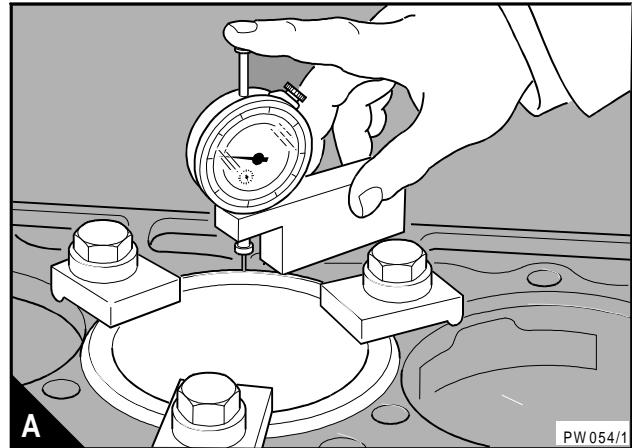

To inspect**16A-4**

Check the cylinder liners for damage and wear.

To check the wear of the liner see (A) and (B) and compare the results with data and dimensions.

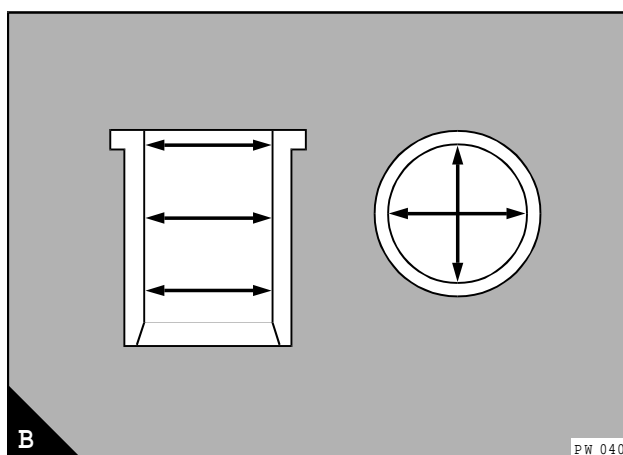
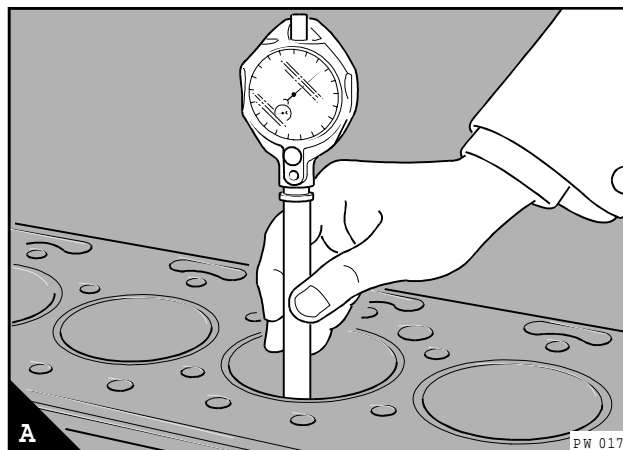

Data and dimensions

Note: This information is given as a guide for personnel engaged on engine overhauls. The dimensions which are shown are those which are mainly used in the factory. The information applies to all engines, unless an engine type code is shown.

Cylinder block

Face flatness.....	0,08 mm (0.003 in)
Diameter of parent bore for cylinder liner.....	104,20/104,23 mm (4.103/4.104 in)
Depth of recess for flange of cylinder liner.....	3,81/3,91 mm (0.150/0.154 in)
Diameter of recess for flange of cylinder liner.....	107,82/107,95 mm (4.245/4.250 in)
Diameter of parent bore for main bearing.....	96,500 +/- 0,0127 mm (3.8491 +/- 0.0005 in)
Internal diameter of piston cooling jet	1,22/1,24 mm (0.048/0.049 in)
Diameters of the parent bores for the camshaft bushes:	
- Number 1	63,513/63,551 mm (2.5005/2.5020 in)
- Number 2	63,005/63,043 mm (2.4805/2.4820 in)
- Number 3	62,497/62,535 mm (2.4605/2.4620 in)
- Number 4	62,103 /62,141mm (2.4450/2.4465 in)

Tappets

diameters:

- Tappet body.....	28,435/28,448 mm (1.1195/1.1200 in))
- Parent bore	28,512/28,550 mm (1.1225/1.1240 in)

Cylinder liners

Type.....	Wet, push fit, flanged
Inside diameter WK and WL engines.....	109,233/109,258 mm (4.3005/4.3015 in)
Inside diameter WM and WN engines	116,573/116,599 mm (4.5895/4.5905 in)
Maximum permissible wear of liner bore	0,10 mm (0.004 in)
Thickness of flange.....	8,94/8,97 mm (0.352/0.353 in)
Flange protrusion above the top face of the cylinder block.....	0,050/0,127 mm (0.002/0.005 in)

17A

Engine timing

General description

The marked teeth of the crankshaft gear, the camshaft gear and the two idler gears will be in mesh when number 1 piston is at TDC on the compression stroke. The marked teeth of the idler gears may not necessarily be in mesh, in this position, because of the different speeds at which the gears rotate.

With all of the marks aligned, the crankshaft will require 37 revolutions for all of the marks to align again.

There are no timing marks on the gear for the high-pressure pump.

To set number one cylinder to TDC on the compression stroke **17A-1**

- 1 Remove the rocker cover, [see operation 12A-1](#).
- 2 Slowly rotate the crankshaft clockwise, from the front, until the timing mark on the pulley/damper assembly aligns with the pointer on the timing case.
- 3 Check that the push rods of number 1 cylinder are free to rotate. Number 1 piston is now at TDC on the compression stroke.

Note: If the push rods are not free to rotate, this indicates that number 1 cylinder is on the exhaust stroke. Rotate the crankshaft one turn and align the timing marks.

17A

To check the valve timing (with a feeler gauge)

17A-2

- 1 Set the piston of number 1 cylinder to TDC on the compression stroke, [see operation 17A-1](#).
- 2 Set the valve tip clearance of number one inlet valve to 0,74 mm (0.029 in).
- 3 Rotate the crankshaft clockwise, from the front, until number one exhaust valve has just opened.
- 4 Put a 0,10 mm (0.004 in) feeler gauge between the valve stem and the rocker lever of number one inlet valve.
- 5 Slowly rotate the crankshaft clockwise, from the front, until the feeler gauge is tight. This is the point where the inlet valve of number one cylinder will begin to open. The timing mark on the pulley/ damper assembly should be at $24.5^\circ \pm 3.5^\circ$ BTDC. If the valve timing is correct set the valve tip clearance of number one inlet valve to 0,64 mm (0.025 in).
- 6 Fit the rocker cover, [see operation 12A-1](#).

If the reading is incorrect remove the timing case cover, [see operation 15A-1](#). Check the timing marks on the timing gears.

Note: Adjustment of the timing by one tooth on the timing gears = 11° or 30 mm (1.2 in) on the circumference of the pulley/damper assembly.

To check the valve timing (with a dial test indicator)

17A-3

- 1 Set the piston of number 1 cylinder to TDC on the compression stroke, [see operation 17A-1](#).
- 2 Set the valve tip clearance of number one inlet valve to 0,74 mm (0.029 in).
- 3 Set a dial test indicator to zero against the valve rotator of number one inlet valve.
- 4 Slowly rotate the crankshaft clockwise, from the front, one full turn. The reading on the dial indicator should be 3,93/5,59 mm (0.155/0.220 in). If the reading is correct, set the valve tip clearance of number one inlet valve to 0,64 mm (0.025 in).
- 5 Remove the dial test indicator.
- 6 Fit the rocker cover, [see operation 12A-1](#).

If the reading is incorrect, remove the timing case cover, [see operation 15A-1](#). and check the timing marks on the timing gears.

Note: Adjustment of the timing by one tooth on the timing gears = 11° or 30 mm (1.2 in) on the circumference of the pulley/damper assembly.

18A

Turbocharger

General description

Warning! *Turbochargers operate at high speed and at high temperatures. Keep fingers, tools and other objects away from the inlet and outlet ports of the turbocharger and avoid contact with hot surfaces.*

A turbocharger, is fitted between the exhaust and induction manifolds. The turbocharger is driven by exhaust gases and supplies air to the engine at more than atmospheric pressure. The turbocharger is lubricated by oil from the oil filter head. The oil passes through the bearing housing of the turbocharger and returns to the lubricating oil sump.

Some turbochargers are fitted with a waste-gate unit. This unit, which is controlled by boost pressure, allows some of the exhaust gases to by-pass the turbine rotor at higher engine speeds. With this arrangement, the turbocharger can be designed to be more effective at lower engine speeds.

Always use the manufacturers instructions and specialist assistance to fit the service kit for the turbocharger.

Caution: *Do not use a caustic solution to clean the components of the turbocharger because the turbocharger will be damaged.*

To remove

Warning! Turbochargers operate at high speed and at high temperatures. Keep fingers, tools and other objects away from the inlet and outlet ports of the turbocharger and avoid contact with hot surfaces.

- 1 Thoroughly clean the turbocharger.
- 2 Remove the air cleaner hose at the compressor inlet.
- 3 Remove the hose from the compressor outlet.
- 4 Release the setscrews (A1) from the flange (A2) of the oil supply pipe (A4) at the top of the bearing housing.
- 5 Release the union nut/connection (A6) at the other end of the pipe on the oil filter head. Use a spanner to hold the union (A5) on the filter head when the union nut is released.
- 6 Remove the pipe and discard the flange joint (A3).
- 7 Remove the setscrews (B7) from the flange (B2) of the oil drain pipe (B5) at the bottom of the bearing housing.
- 8 Remove the setscrew (B4) and the clamp (B3), at the other end of the pipe.
- 9 Remove the oil drain pipe and discard its two 'O' rings (B6) and flange joint (B1).
- 10 Hold the turbocharger and release the setscrews that retain the turbocharger to exhaust manifold. Remove the turbocharger and discard the gasket.
- 11 Cover the openings in the manifolds and the pipes to ensure that debris will not enter.

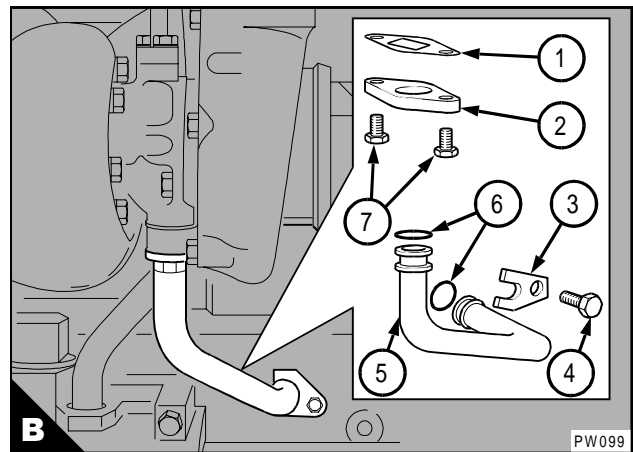
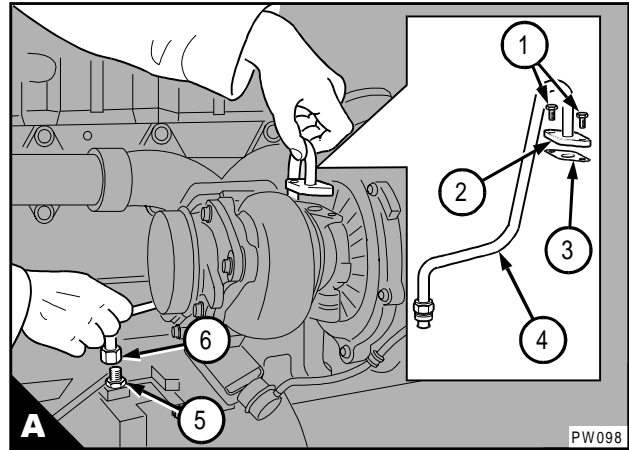

To fit

- 1 Remove the covers from the pipes and manifolds.
- 2 Check that the turbocharger inlet and outlet are clean and free from restriction. Check that the turbocharger shaft rotates freely. Also check that the openings in the manifolds and the exhaust pipe are clean and free from restriction.
- 3 Fit a new gasket to the exhaust manifold to turbocharger flange.
- 4 Put the turbocharger in position and hold it. Fit the setscrews and tighten them to 68 Nm (50 lbf ft) 6,9 kgf m.
- 5 Put a suitable container under the turbocharger to contain the oil from the oil drain outlet of the turbocharger.
- 6 Pour 140 cm³ (0.25 pints) of clean engine lubricating oil into the oil supply port of the bearing housing.
- 7 Fit a new joint (A3) to the oil supply port on the top of the turbocharger.
- 8 Clean the threads of the union connection (A5 and A6) and apply a thread sealant to the union connection (A5).
- 9 Put the oil supply pipe (A4) in position, fit but do not tighten the flange setscrews (A1).
- 10 Use a spanner to hold the union connection (A5) while the union nut (A6) on the pipe is tightened.
- 11 Tighten the flange setscrews (A1).
- 12 Fit the air cleaner hose to the compressor inlet.
- 13 Fit the compressor outlet hose.
- 14 Fit a new joint (B1), the flange (B2) and two new 'O' rings (B6) onto the oil drain pipe (B5).
- 15 Install the oil drain pipe into its port in the crankcase. Put and hold the flanged end of the oil drain pipe against the oil drain port, at the bottom of the turbocharger.
- 16 Fit but do not tighten the two flange setscrews (B7).
- 17 Put the pipe clamp (B3) in position and hold it. Fit but do not tighten the setscrew (B4).
- 18 Tighten the three setscrews evenly and gradually.
- 19 Remove the container and dispose of the lubricating oil in a safe place in accordance with local regulations.

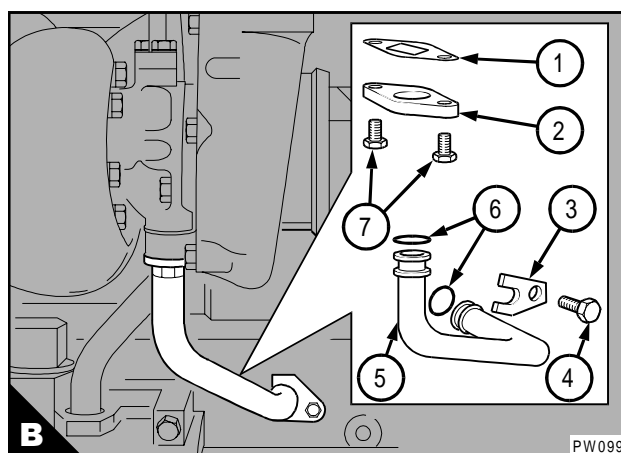
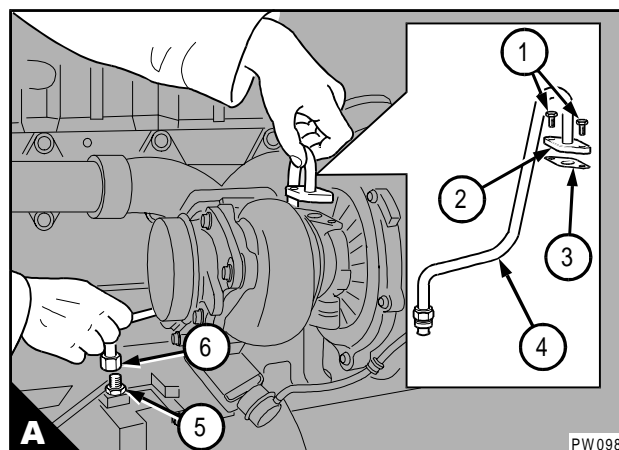

To dismantle

Note: The components of the rotating assembly and the components of the bearing housing, except the backplate 'O' ring, have been withdrawn as service items. If there is a failure of these components, or if they are excessively worn, the complete bearing housing and rotating assembly must be renewed as a unit.

- 1 Remove the turbocharger from the engine, [see operation 18A-1](#).
- 2 Put reference marks (A) on the compressor casing, on the backplate and on the turbine housing to ensure correct assembly later.
- 3 Hold the turbocharger in a vice which is fitted with soft jaws to protect the turbocharger.
- 4 Remove the boost sensor pipe (B1) at the waste-gate actuator (B4). Remove the waste-gate actuator and bracket assembly, [see operation 18A-5](#).
- 5 Remove the six setscrews (B2) which hold the compressor casing (B3) to the backplate (C6), remove the three lock plates.
- 6 Remove carefully the compressor casing from the turbocharger. If the casing is tight, lightly hit it with a soft faced hammer.
- 7 Remove the compressor housing seal (C7).

Caution: To change the angle of the compressor inlet, the casing must be removed completely and then fitted again. Do not turn the casing while it is fitted to the turbocharger because the compressor housing seal will be damaged.

- 8 Remove the six setscrews (C3) which hold the waste-gate housing (C4) to the turbine casing (C2) and remove the waste-gate housing.
- 9 Remove the four setscrews (C1) which hold the bearing housing assembly (C5) to the turbine casing, remove the bearing housing assembly.

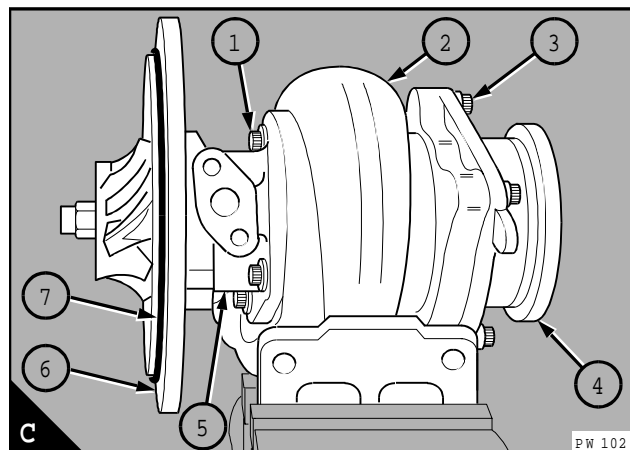
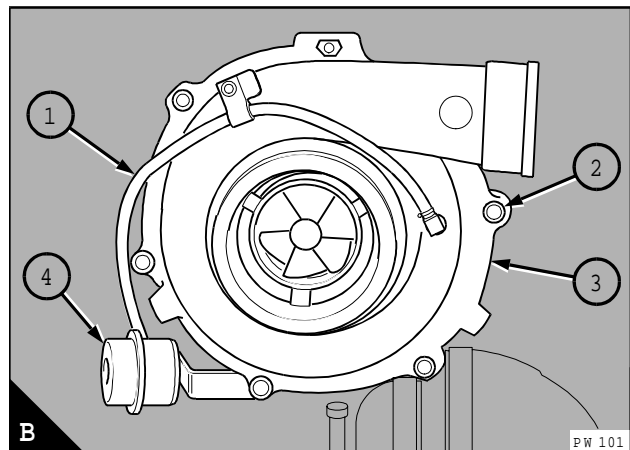
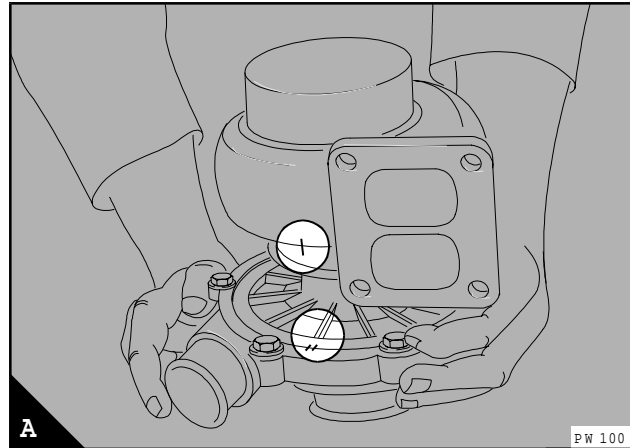

To assemble

- 1 Fit the waste-gate housing (C4) to the turbine housing (C2), fit and tighten the six setscrews (C3).
- 2 Fit the bearing housing assembly (C5) to the turbine housing (C2) and align the marks (A). Tighten the four setscrews (C1) to 13 Nm (9.6 lbf ft) 1,3 kgf m.
- 3 Fit the compressor housing seal (C7).
- 4 Fit the compressor housing to the backplate (C6) and align the marks (A). Fit the three lock plates and the six setscrews (B2), tighten the setscrews to 23 Nm (17 lbf ft) 2,35 kgf m.

Caution: *To change the angle of the compressor inlet, the casing must be removed completely and then fitted again. Do not turn the casing while it is fitted to the turbocharger because the compressor seal will be damaged.*

- 5 Check that the turbine rotates freely.
- 6 Fit the waste-gate actuator and bracket assembly, see operation 18A-5.

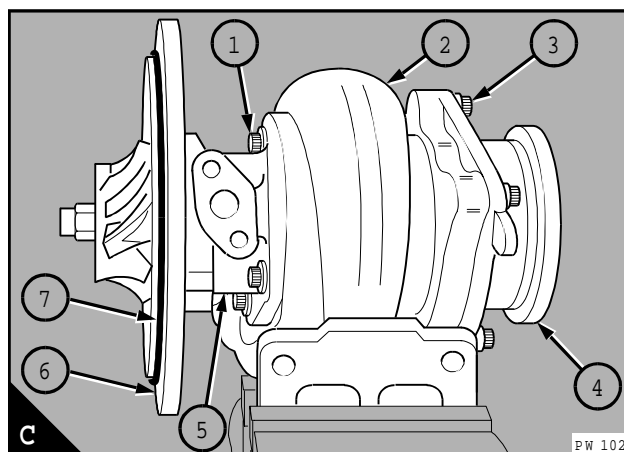
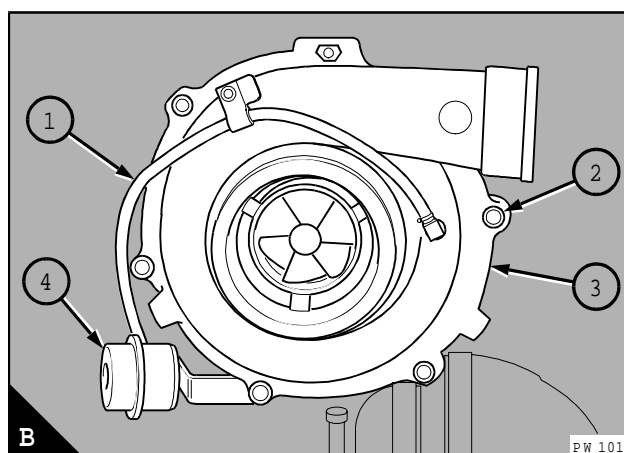
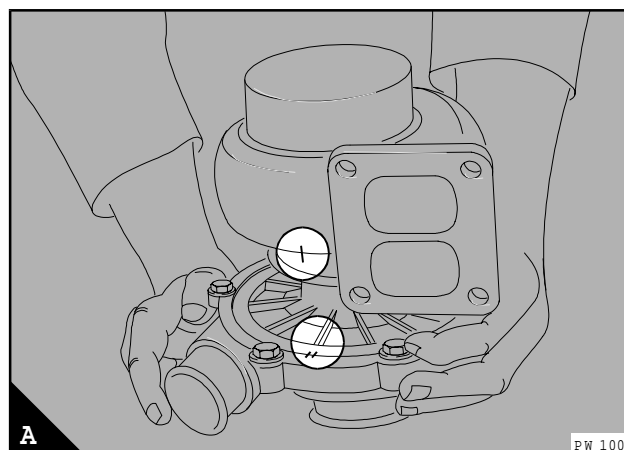

18A

To inspect

18A-3

Caution: Do not straighten the blades of the impeller or the turbine. If they are bent or damaged, the turbocharger must be renewed.

- 1 Remove the turbocharge, [see operation 18A-1](#).
- 2 Visually inspect the turbocharger for damage and leaks.
- 3 Ensure that the turbine shaft turns freely.
- 4 Check the actuator rod movement, [see operation 18A-6](#).
- 5 Put a dial gauge (A) on the turbocharger to measure the end-float of the turbine shaft. Ensure that the tip of the gauge is in contact with the end of the turbine shaft. Push the shaft fully in one direction and set the gauge to zero. Push the shaft fully in the other direction and record the reading on the gauge. The correct end-float tolerance is 0,02-0,10 mm (0.001-0.004 in). If the end-float is out of tolerance the turbocharger must be renewed.

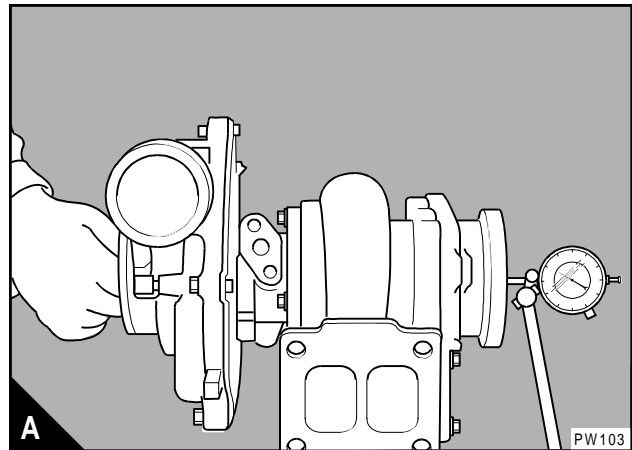

To clean the impeller and compressor casing

18A-4

- 1 Remove the compressor casing, [see operation 18A-2](#).
- 2 Put the compressor casing in a suitable container that contains a non-caustic solution. Allow the dirt to become soft and then clean the casing with a hard brush and/or a soft scraper. Dry the casing with clean, compressed air at low pressure.
- 3 Clean the impeller with a soft brush.
- 4 Fit the compressor casing, [see operation 18A-2](#).

To remove and to fit the actuator assembly of the waste-gate unit

18A-5

To remove

Caution: Do not operate the actuator rod by hand, because the calibration of the actuator will be affected. This may cause damage to the engine.

- 1 Disconnect the boost sensor pipe at the actuator.
- 2 Remove the clip (A1) which retains the actuator rod (A3).
- 3 Release the three setscrews (A6) which retain the waste-gate actuator and bracket assembly (A5) to the turbocharger.
- 4 Remove the actuator and bracket assembly as a unit, and at the same time, lift the end of the actuator rod off the arm of the waste-gate valve (A2).

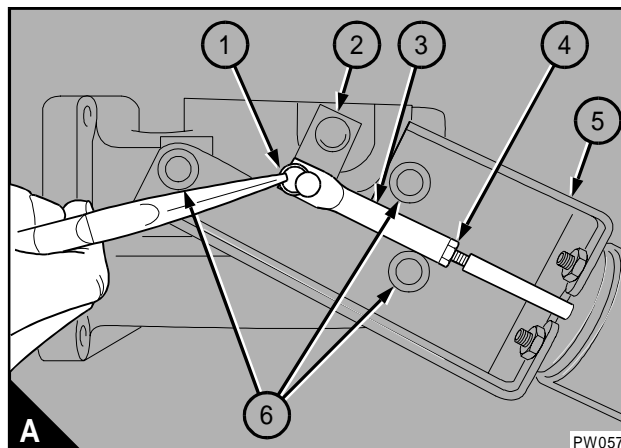

To check and to adjust the actuator assembly of the waste-gate unit

18A-6

Note:

- If the waste-gate valve does not operate at the correct pressure, it can affect the engine performance.
- If the valve opens at a low pressure, this can cause black exhaust smoke and loss of power at lower engine speeds.

Cautions:

- *A high pressure setting can cause high cylinder pressures which can cause failure of the cylinder head gasket and can cause damage to the bearings and pistons.*
- *Do not apply an air pressure of more than 207 kPa (30 lbf/in²) 2,1 kgf/cm² to the actuator. Higher pressures may damage the actuator.*
- *Do not operate the actuator rod (A3) by hand, because the calibration of the actuator will be affected, and this may cause damage to the engine.*

To check

- 1 Disconnect the boost sensor pipe at the actuator.
- 2 Connect the actuator to an air supply which has a pressure regulator (A5) and is fitted with an accurate gauge (A4).
- 3 Fasten a dial gauge (A6) to the turbocharger with its plunger in contact with the end of the actuator rod (A2), to measure the axial movement of the rod.
- 4 Slowly apply air pressure and check that the rod moves 0,381 mm (0.015 in) at 197 kPa (28.5 lbf in²) 2,0 kgf cm². Ensure that the pointer returns to zero when the pressure is released.
- 5 Repeat paragraph 4 of the operation several times, to ensure that an accurate reading is obtained
 - If the axial movement of the rod is correct, no adjustment is necessary. Remove the air supply and remove the dial gauge.
 - If the axial movement of the rod is wrong, adjustment is necessary, [see operation 18A-6](#). Remove the dial gauge.

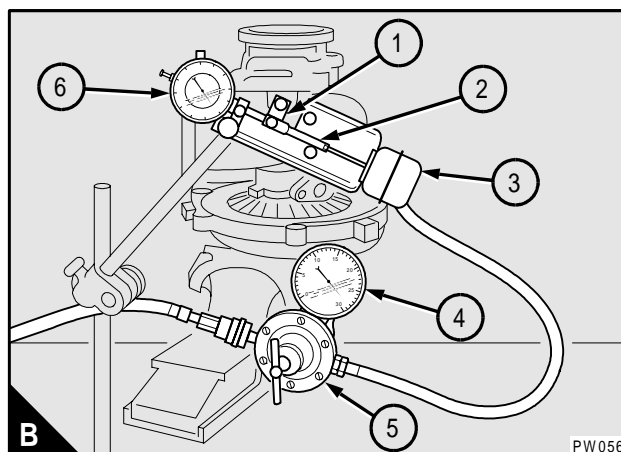

18A

To adjust

1 Check the operation of the actuator assembly, see operation 18A-6.

2 With the air pressure still applied, release the locknut (A4) on the actuator rod. Remove the clip (A1) and lift the actuator rod (A3) from the arm (A2) of the waste-gate valve.

- If the air pressure was too low, turn the end of the actuator rod to reduce its overall length.
- If the air pressure was too high, turn the end of the actuator rod to increase its overall length.

Note: Turn the end of the actuator rod in half-turn increments.

Caution: Use only the end of the threaded rod to make adjustments. To pull or push the actuator rod could change the calibration of the actuator. The result could be damage to the engine because of too much boost.

3 Put the actuator rod in position on the arm of the waste-gate valve.

4 Check the operation of the actuator assembly, see operation 18A-6.

5 Repeat the adjustment procedure until the axial movement of the actuator rod is correct.

6 Fit the clip (A1).

7 Tighten the locknut (A4).

8 Release the air pressure.

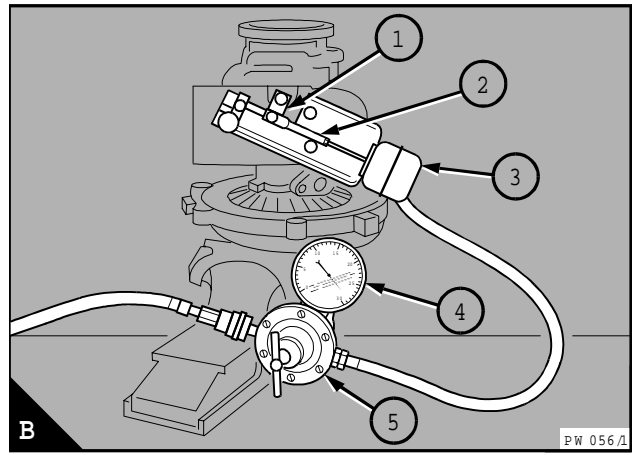
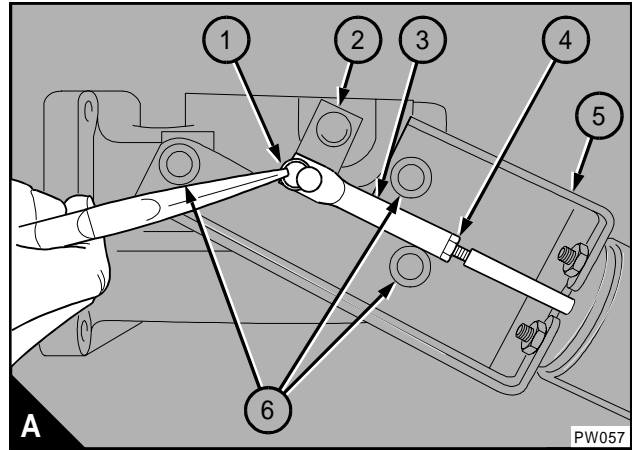

This page has been
left blank intentionally

18A

Turbocharger faults

The chart below is given to assist in the correct diagnosis of turbocharger faults.

Problems	Possible causes, code numbers
Not enough power	1, 4, 5, 6, 7, 8, 9, 10, 11, 18, 20, 21, 22, 25, 26, 27, 28, 34, 35, 36
Black smoke	1, 4, 5, 6, 7, 8, 9, 10, 11, 18, 20, 21, 22, 25, 26, 27, 28, 34, 35, 36
Blue smoke	1, 2, 4, 6, 8, 9, 17, 19, 20, 21, 22, 30, 31, 32, 34
High consumption of lubricating oil	2, 8, 15, 17, 19, 20, 28, 29, 31, 32, 34
Too much lubricating oil at the turbine end	2, 7, 8, 17, 19, 20, 22, 28, 30, 31, 32
Too much lubricating oil at the compressor end	1, 2, 4, 5, 6, 8, 19, 20, 21, 28, 31, 32
Not enough lubrication	8, 12, 14, 15, 16, 23, 24, 29, 32, 33, 37, 38
Lubricating oil in the exhaust manifold	2, 7, 17, 18, 19, 20, 22, 28, 31, 32
Inside of the induction manifold wet	1, 2, 3, 4, 5, 6, 8, 10, 11, 17, 18, 19, 20, 21, 28, 32, 34, 39, 40
Damaged compressor impeller	3, 4, 6, 8, 12, 15, 16, 20, 21, 23, 24, 29, 32, 33, 37, 38
Damaged turbine rotor	7, 8, 12, 13, 14, 15, 16, 18, 20, 22, 23, 24, 25, 27, 29, 32, 33, 37, 38
Rotating assembly does not turn freely	3, 6, 7, 8, 12, 13, 14, 15, 16, 18, 20, 22, 23, 24, 29, 32, 33, 37, 38
Worn bearings, bearing bores or journals	6, 7, 8, 12, 13, 14, 15, 16, 23, 24, 29, 33, 37, 38
Noise from the turbocharger	1, 3, 4, 5, 6, 7, 8, 9, 10, 11, 12, 13, 14, 15, 16, 18, 20, 21, 22, 23, 24, 29, 32, 33, 34, 37, 38,
Sludge or carbon deposit in the bearing housing	2, 11, 13, 14, 15, 17, 18, 24, 29, 33, 37, 38

Faults codes

- 1 Element of the air filter dirty
- 2 Restricted crankcase breather
- 3 Element of the air filter missing, leaking or not sealing correctly. Loose connection to turbocharger.
- 4 Internal distortion or restriction in pipe from air filter to turbocharger.
- 5 Damaged/restricted crossover pipe, turbocharger to induction manifold.
- 6 Restriction between air filter and turbocharger.
- 7 Restriction in exhaust system.
- 8 Turbocharger loose or clamps/setscrews loose.
- 9 Induction manifold cracked or loose, flanges distorted.
- 10 Exhaust manifold cracked or loose, flanges distorted.
- 11 Restricted exhaust system.
- 12 Delay of lubricating oil to turbocharger at engine start.
- 13 Insufficient lubrication.
- 14 Dirty lubricating oil.
- 15 Incorrect lubricating oil.
- 16 Restricted lubricating oil supply pipe.
- 17 Restricted lubricating oil drain pipe.
- 18 Turbine housing damaged or restricted.
- 19 Leakage from turbocharger seals.
- 20 Worn turbocharger bearings.
- 21 Excessive dirt in compressor housing.
- 22 Excessive carbon behind turbine rotor.
- 23 Engine speed raised too rapidly at initial start.
- 24 Insufficient engine idle period.
- 25 Faulty fuel injection pump.
- 26 Worn or damaged atomisers.
- 27 Valves burned.
- 28 Worn piston rings.
- 29 Lubricating oil leakage from supply pipe.
- 30 Excessive preservation fluid (on initial engine start).
- 31 Excessive engine idle period.
- 32 Restriction in turbocharger bearing housing.
- 33 Restriction in lubricating oil filter.
- 34 Wet type air cleaner: Restricted, dirty element, viscosity of oil too low/high.
- 35 Waste-gate actuator faulty or damaged.
- 36 Waste-gate valve not free.
- 37 Engine stopped too soon from high load.
- 38 Insufficient lubricating oil.
- 39 Fuel leakage from fuelled starting aid.
- 40 Crack in backplate of compressor.

18A

Data and dimensions

Note: This information is given as a guide for personnel engaged on engine overhauls. The dimensions which are shown are those which are mainly used in the factory. The information applies to all engines, unless an engine type code is shown.

Turbocharger

Shaft end-float.....	0,025/0,100 mm (0.001/0.004 in)
Shaft clearance.....	0,08/0,15 mm (0.003/0.006 in)
Waste-gate actuator movement.....	0,38 mm at 196 kPa (0.015 in at 28.5 lbf/in ²)

19A

Lubrication system - low-pressure

This page has been
left blank intentionally

General description

Lubricating oil from the sump passes through a strainer and a pipe into a channel in the timing case. The lubricating oil passes through the channel to the inlet of the oil pump.

The lubricating oil passes from the oil pump, under pressure, through a channel in the timing case. The oil either passes through a relief valve which is fitted in the timing case or passes into an oil pressure rail. The relief valve opens at 551 kPa (80 lbf/in²) 5,6 kgf/cm² and returns the oil to the sump.

A temperature / pressure control valve in the oil filter head controls the flow of oil from the pressure rail. If the oil is hot (A2), the valve will open and the oil passes through the oil cooler to the oil filter head and then into the filter. If the oil is cold (A3), the valve closes and the oil passes directly to the oil filter.

Clean lubricating oil (A1) passes from the filter to a regulator valve which operates at 345 kPa (50 lbf/in²) 3,51 kgf/cm². If a restriction occurs in the filter element, a by-pass valve fitted in the filter housing opens. Oil which by-passes the filter passes directly to the regulator valve. The regulator valve either by-passes oil to the sump or allows oil to pass to the main pressure rail and then through ports in the cylinder block to the crankshaft main journals.

Lubricating oil from the main pressure rail also passes:

- to jets in the crankcase which spray oil on the underside of the pistons to cool them.
- through a channel in crankcase and in the timing case to the reservoir for the high-pressure pump.

There are ports in the crankcase through which oil passes to the camshaft journals.

Lubricating oil passes through holes drilled in the crankshaft journals to the crank pins to lubricate the big end bearings.

Lubricating oil from the rear journal of the crankshaft passes to the rear of the rocker shaft. The oil passes along the hollow rocker shaft to lubricate the rockers.

The turbocharger receives clean oil from the oil filter head, through a pipe. The oil passes through the bearing housing of the turbocharger and returns through a pipe to the crankcase, and then to the sump.

The compressor, if fitted, receives oil from a union connection fitted to the cylinder block. Lubricating oil from the main pressure rail passes through a drilled hole to the union, the oil then passes to the compressor. Lubricating oil from the compressor returns to the sump.

(A)

- 1 Filtered oil
- 2 Hot oil
- 3 Cold oil

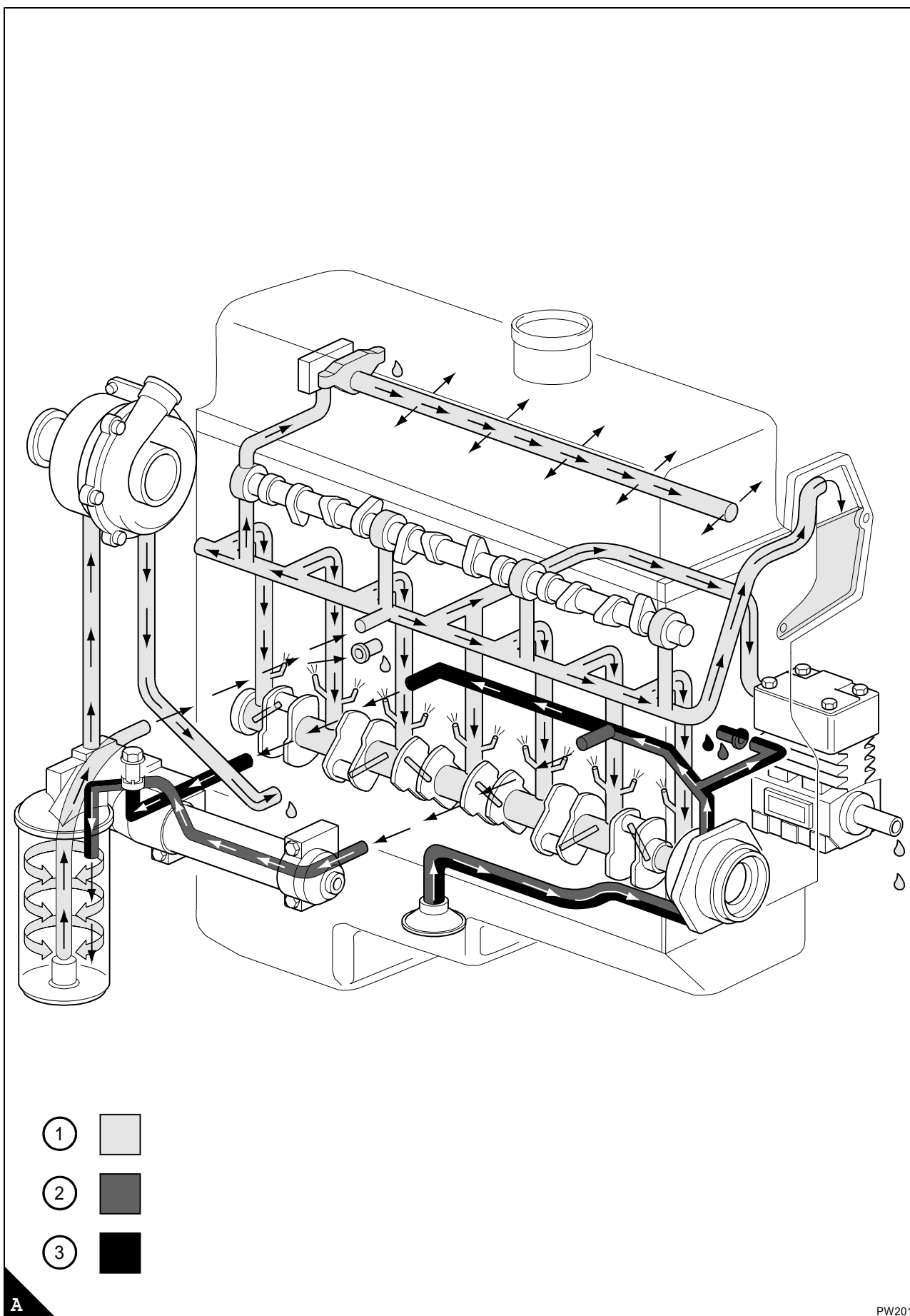

PW201

19A

Filter canister

To renew the canister of the lubricating oil filter

19A-1

Warning! Discard the used canister and lubricating oil in a safe place and in accordance with local regulations.

Caution: Ensure that the application is on a level surface to ensure an accurate reading on the dipstick.

1 Operate the engine before the oil filter is removed. This ensures that oil is in the bearing housing of the turbocharger.

2 Put a tray under the filter to retain lubricating oil.

3 Clean thoroughly the outside surfaces of the filter assembly.

4 Use a strap wrench or similar tool to loosen the filter canister. Remove and discard the canister. Ensure that the adaptor (A1) is secure in the filter head.

Warning! Discard the used canister and lubricating oil in a safe place and in accordance with local regulations.

5 Clean inside the filter head.

6 Lubricate the seal (A2) on top of the canister with clean engine lubricating oil.

7 Fit the new canister and tighten it by hand until the seal contacts the filter head. Tighten the canister a further 1/2 to 3/4 of a turn by hand only. Do not use a strap wrench.

8 Ensure that there is lubricating oil in the sump.

9 Turn the start key to the "ON" position and start the engine.

Note: The engine will not start and operate until oil pressure is obtained. Oil pressure is indicated when the warning light is extinguished or by a reading on the gauge.

Caution: Do not fill the sump past the "FULL" mark on the dipstick.

10 When the engine starts check for leakage from the filter. Stop the engine. After 15 minutes check the oil level on the dipstick and, if necessary, put more lubricating oil into the sump.

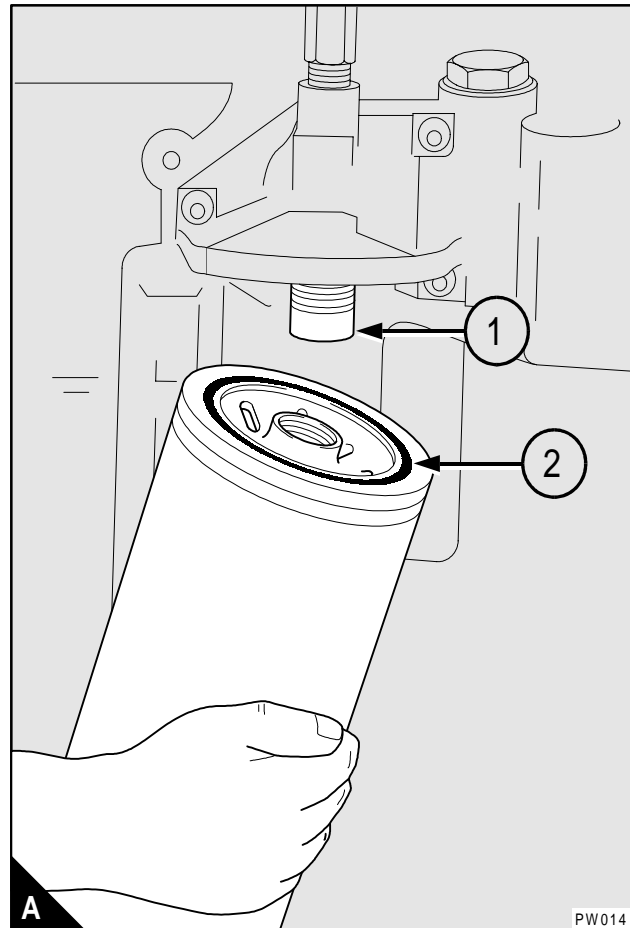

Filter head and oil cooler assembly

Note: The casting for the oil filter head includes the rear end-casing for the oil cooler (A7) and houses the oil temperature / pressure control valve. The filter head and the oil cooler are an assembly.

To remove and to fit

19A-2

Consumable products:

POWERPART Threadlock (pipe)

To remove

- 1 Drain the lubricating system.
- 2 Drain the cooling system.
- 3 Remove the lubricating oil canister (A8), see operation 19A-1.
- 4 Disconnect the oil supply pipe (A10) for the turbocharger.
- 5 Remove the setscrew from the clamp (A3) for the coolant inlet pipe (A1).
- 6 Release the setscrews and remove the filter head and oil cooler assembly (B) from the cylinder block.
- 7 Discard the joints (A4) from the filter head and discard the 'O' rings (A2) from the coolant inlet pipe.
- 8 Remove the coolant outlet pipe (A5) and discard the 'O' rings (A6) from the coolant outlet pipe.

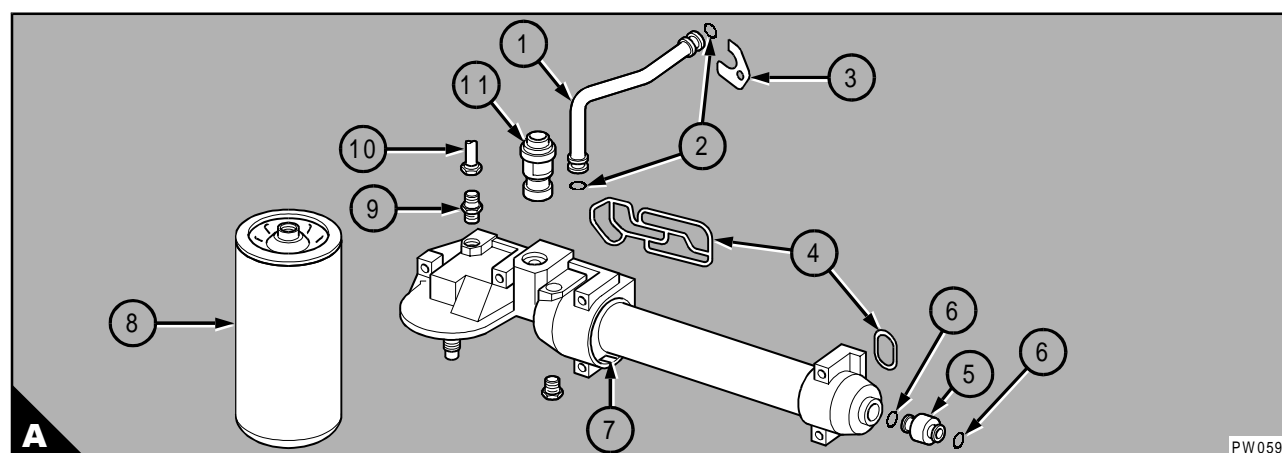
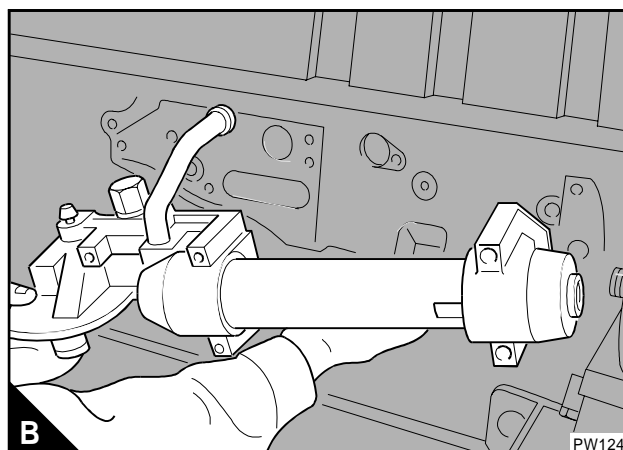

19A

To fit

- 1 Clean the outside of the filter head and oil cooler assembly (A7). Clean the joint face on the cylinder block, the coolant inlet pipe (A1) and coolant outlet pipe (A5).
- 2 Fit new joints (A4) to the filter head and fit new 'O' rings (A2 and A6) to the coolant inlet and outlet pipes.
- 3 Put the filter head and oil cooler assembly (B) in position on the cylinder block. Ensure that the coolant inlet pipe is correctly engaged in the cylinder block and in the filter head. Fit and tighten the setscrews for the filter head / oil cooler assembly.
- 4 Fit and tighten the setscrew for the clamp (A3) of the coolant inlet pipe.
- 5 Clean the threads of the union connection (A9) for the turbocharger pipe (A10). Apply POWERPART Threadlock (pipe) to the thread of the connection which enters the filter head. Use a separate spanner to hold the union connection while the union nut on the pipe is tightened.
- 6 Fit a new oil filter canister (A8), see operation 19A-1.
- 7 Fill the cooling system to the correct level.
- 8 Fill the sump to the correct level with lubricating oil of an approved grade.

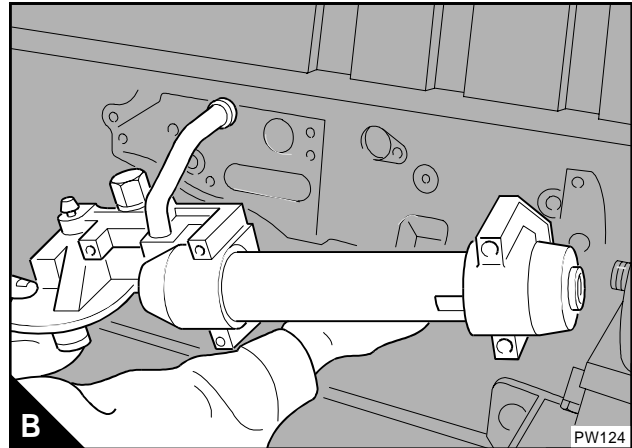

To inspect

19A-3

- 1 Visually inspect the filter head and oil cooler assembly for damage and for signs of leakage of coolant or lubricating oil. If there is a leakage from the oil cooler it must be renewed.
- 2 Inspect the joint and seal faces for damage.
- 3 Remove the oil temperature / pressure control valve (A11) and inspect it for damage.
- 4 Fit the valve and tighten it to 13,5 Nm (10 lbf ft) 1,3 kgf m.

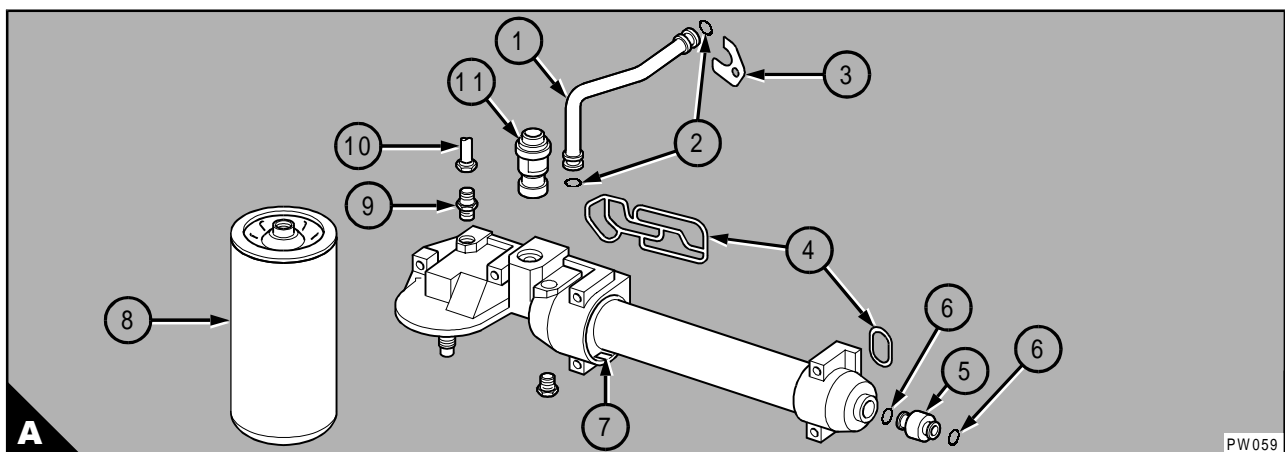

Oil temperature / pressure control valve

Note: The oil temperature / pressure control valve (19A.8/A11) is fitted into the top of the filter head/ oil cooler assembly.

To remove and to fit

19A-4

To remove

- 1 Drain the lubricating oil.
- 2 Remove the oil temperature control valve and discard the "O" ring.

To fit

- 1 Fit a new "O" ring to the valve.
- 2 Fit the oil temperature / pressure control valve and tighten it to 13,5 Nm (10 lbf ft) 1,3 kgf m.
- 3 Fill the lubricating oil system to the correct level with an approved oil.

To test

19A-5

- 1 Hang the valve in a suitable container filled with lubricating oil.
- 2 Heat the oil gradually. Use a thermometer to check the temperature at which the valve starts to open and at which it is fully open. The correct temperatures are given in data and dimensions.

19A

Pressure regulating valve

Note: The pressure regulating valve (A1) operates at 345 kpa (50 lbf/in²) and is fitted into the crankcase, behind the oil filter head.

To remove and to fit

19A-6

To remove

- 1 Remove the filter head and oil cooler assembly, [see operation 19A-2](#).
- 2 Push the pressure regulating valve open and insert a piece of copper wire into the valve. Use the copper wire to pull the valve from the crankcase.

To fit

- 1 Clean the filter head and cooler assembly, the joint face on the cylinder block and the coolant inlet and outlet pipes.
- 2 Fit the pressure regulating valve into position in the crankcase.
- 3 Fit the filter head and oil cooler assembly, [see operation 19A-2](#).

To inspect

19A-7

- 1 Visually inspect the valve assembly for damage.
- 2 Remove the circlip and the valve spring from the valve body.
- 3 Measure the free length of the valve springs and compare it with the data and dimensions.
- 4 Measure the spring under a load of 107 N (24.1 lbf) and compare it with the data and dimensions.

Caution: *If the pressure regulating valve is damaged or the spring measurements are incorrect, then the pressure regulating valve must be renewed.*

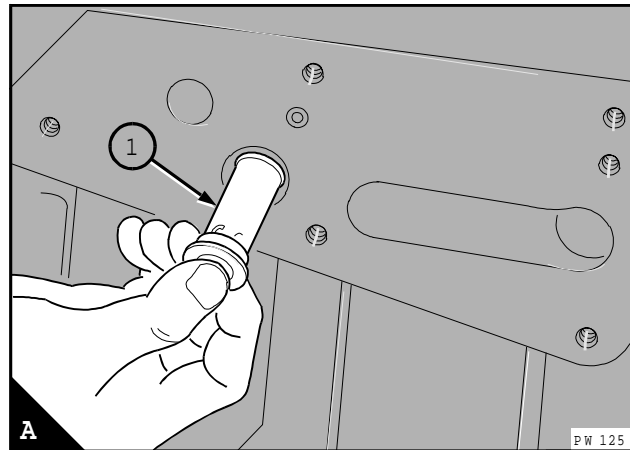

Sump

To remove and to fit

19A-8

Consumable products:

POWERPART Silicon rubber sealant

Note: Manufacture locally four guide dowels. Use the dowels to correctly align the sump, the joint and the metal strips. The dowels should have a thread size of M8 x 1.25, and should have a minimum length of 30 mm.

To remove

- 1 Operate the engine until it is warm.
- 2 Stop the engine.
- 3 Remove the sump drain plug (A4) and discard its "O" ring (A3). Drain the lubricating oil from the sump.
- 4 Remove the dipstick and dipstick tube.
- 5 Provide a support for the sump (A2).
- 6 Remove the 22 setscrews which fasten the sump to the cylinder block, and remove the metal strips (A5).
- 7 Lower the sump.
- 8 Remove the joint (A1).

To fit

- 1 Clean the flange face of the cylinder block.
- 2 Install the four guide dowels, which have been manufactured locally, into the four corners (B1 and B4) of the cylinder block face.
- 3 Apply beads of POWERPART Silicon rubber sealant 6 mm (0.25 in) wide, as shown in (B), to:
 - the timing case (B5)
 - the rear oil seal housing (B2)
 - around the cup plugs (B3).

Caution: Do not apply the sealant more than five minutes before the sump is to be fitted to the engine.

- 4 Put the joint (A1) onto the sump, with the bead of sealant toward the cylinder block.
- 5 Put the sump and the joint in position over the guide dowels, support the sump.
- 6 Put the metal strips (A5) in position against the sump. Fit 10 of the long setscrews through the metal strips and through the sump to secure them to the cylinder block. Tighten the setscrews finger tight.

Continued

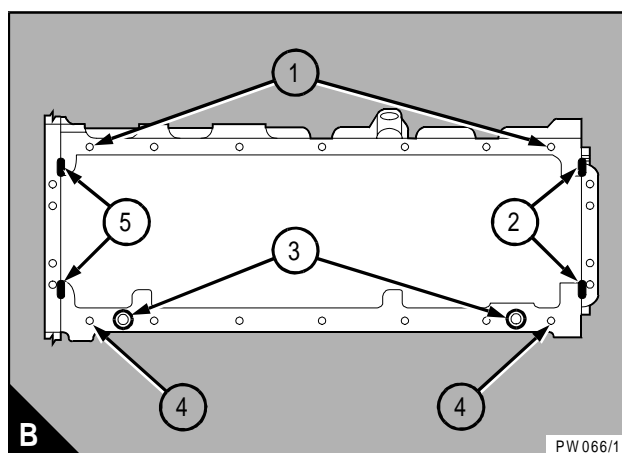
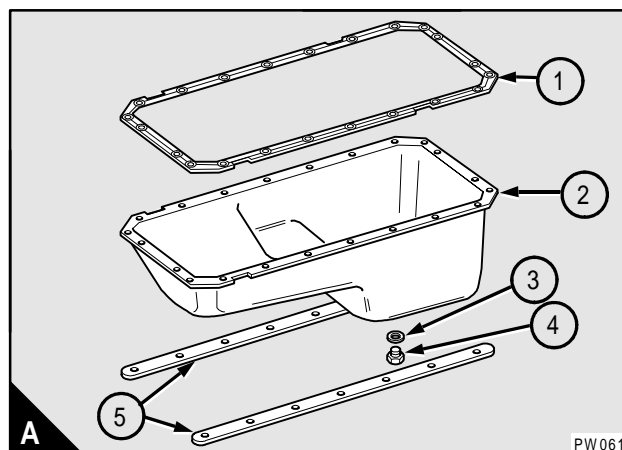

19A

7 Fit four of the short setscrews through the sump and into the timing case. Tighten the setscrews finger tight.

8 Fit the other four short setscrews through the sump and into the rear oil seal housing. Tighten the setscrews finger tight.

9 Remove the guide dowels.

10 Fit the remainder of the long setscrews through the metal strips and through the sump to secure them to the cylinder block. Tighten the setscrews finger tight.

11 Tighten the 22 setscrews to 23 Nm (17 lbf ft) 2,35 kgf m.

12 Fit the drain plug (A4) together with a new "O" ring (A3) and tighten the plug to 68 Nm (50 lbf ft) 7,0 kgf m.

13 Fit the dipstick tube, and fit the dipstick.

14 Fill the sump to the correct level with an approved lubricating oil.

Oil strainer and suction pipe

The oil strainer is an integral part of the suction pipe. No regular service is necessary, but wash the strainer when it is removed.

To remove and to fit

19A-9

To remove

- 1 Drain the lubricating oil.
- 2 Remove the sump, [see operation 19A-8](#).
- 3 Release the setscrews from the flange (A) of the suction pipe.
- 4 Release the setscrew from the support bracket (B) of the suction pipe.
- 5 Remove the setscrews and remove the suction pipe and strainer assembly.
- 6 Discard the joint.

To fit

- 1 Clean the flange face of the suction pipe and the joint face of the crankcase.
- 2 Put the oil strainer and suction pipe, and its new joint in position.
- 3 Fit and tighten the flange setscrews finger-tight.
- 4 Fit and tighten the setscrew for the support bracket finger-tight.

Caution: *The setscrews of the suction pipe must be tightened evenly and gradually to prevent damage that can be caused by stress.*

- 5 Tighten evenly and gradually all three setscrews to 20 Nm (15 lbf ft) 2,1 kgf m.
- 6 Fit the sump, [see operation 19A-8](#).
- 7 Fill the lubricating oil system to the correct level with an approved oil.

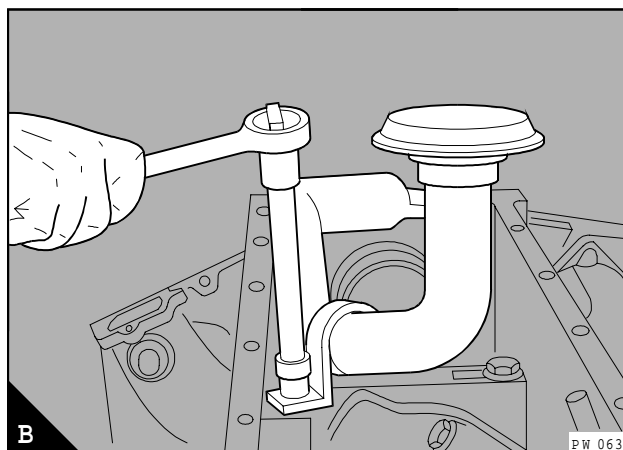
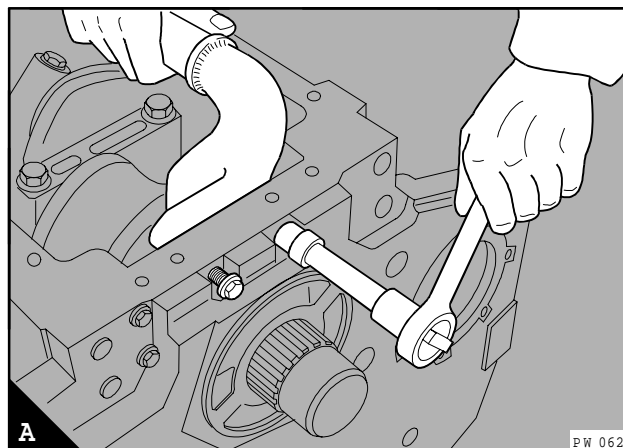

19A

Lubricating oil pump

To remove and to fit

19A-10

Special tools:

Front oil seal installer 21825577

Front oil seal installer adaptor 21825953

To remove

- 1 Drain the lubricating oil.
 - 2 Remove the crankshaft pulley and damper assembly, [see operation 14A-1](#).
 - 3 Remove and discard the front oil seal, [see operation 19A-12](#).
 - 4 Remove the six setscrews of the oil pump.
- Note:** There are short setscrews at the 2 o'clock and the 3 o'clock positions.
- 5 Remove the oil pump body (A1) and discard the 'O' ring (A2).
 - 6 Remove the outer rotor (A3).
 - 7 Remove the key (A4).
 - 8 Remove the oil deflector (B1).

Continued

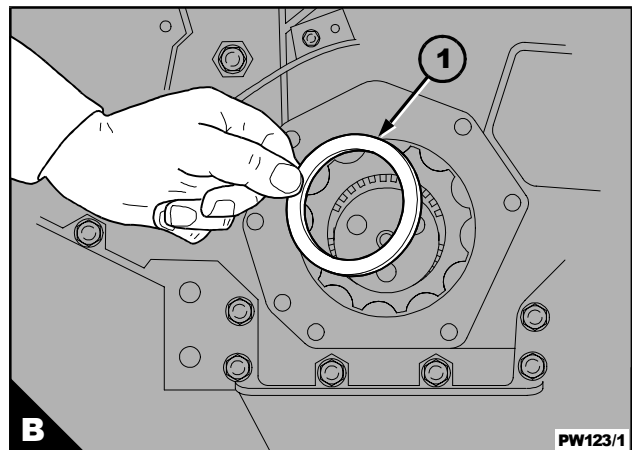
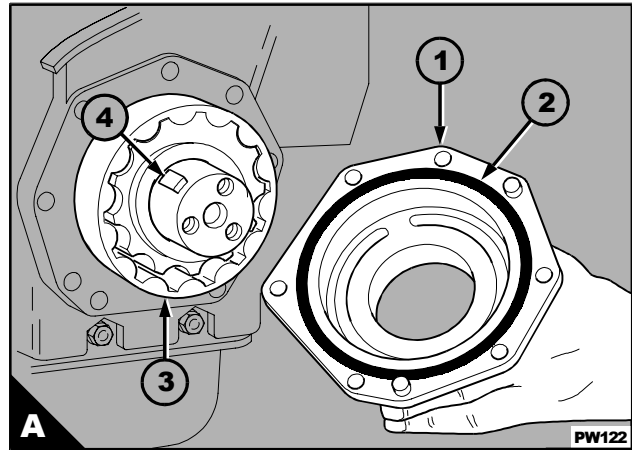

- 9 Remove the inner rotor (A1).
- 10 Remove the backplate (B2).
- 11 Remove and discard the 'O' ring (B1).

To fit

- 1 Clean the components of the lubricating oil pump and clean the face of the timing case cover.
- 2 Fit a new front oil seal into the oil pump body, [see operation 19A-12](#).
- 3 Fit a new 'O' ring (B1) for the backplate into position in the timing case cover.
- 4 Lightly lubricate the backplate (B2) with clean engine lubricating oil. Put the backplate into position on the timing case cover.
- 5 Lightly lubricate the inner rotor (A1) with clean engine lubricating oil. Fit the inner rotor.
- 6 Lightly lubricate the oil deflector (C1) with clean engine lubricating oil. Fit the oil deflector into position on the crankshaft nose.

Note: Fit the oil deflector with the concave side to the inner rotor.

Continued

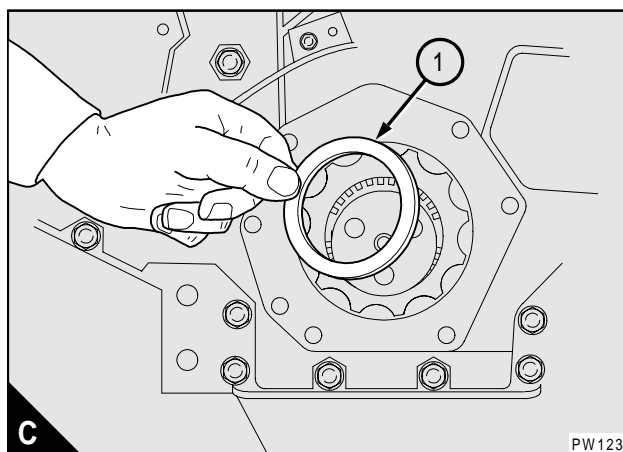
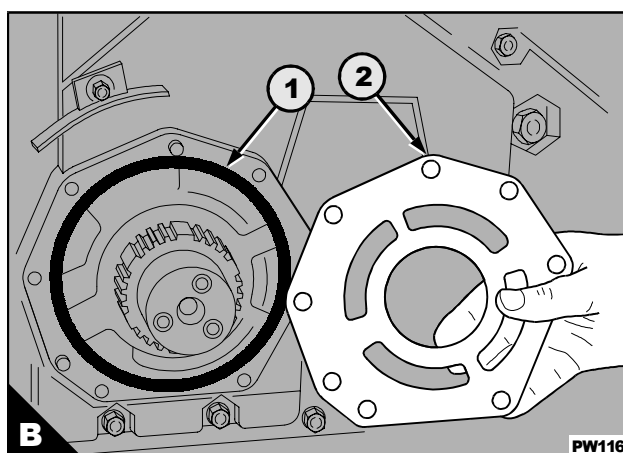
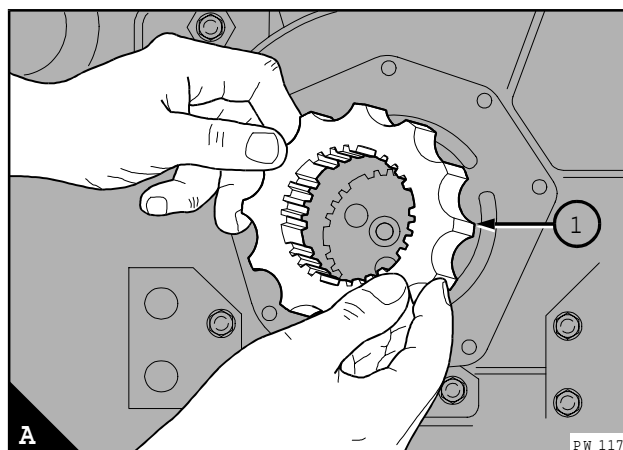

19A

7 Use a hammer carefully to fit the the key (A1) into its recess in the crankshaft nose (A2). Do not damage the key.

8 Lightly lubricate the outer rotor (B3) with clean engine lubricating oil. Fit the outer rotor into the pump body (B2).

9 Fit a new 'O' ring (C1) into its recess in the pump body.

10 Lubricate the main lip of the front oil seal with clean engine lubricating oil. The lubrication of the seal is necessary to prevent damage to the seal when the engine is first started.

11 Fit the pump body, ensure that the outer rotor is in mesh with the inner rotor. Ensure that the dowel pins (B1) in the oil pump body engage with the holes (C2) in the timing case cover.

Caution: Fit a short setscrew at the 2 o'clock and the 3 o'clock positions.

12 Fit and tighten the setscrews.

13 Fit the crankshaft pulley / damper assembly, see operation 14A-1.

14 Fill the lubricating system to the correct level with an approved lubricating oil.

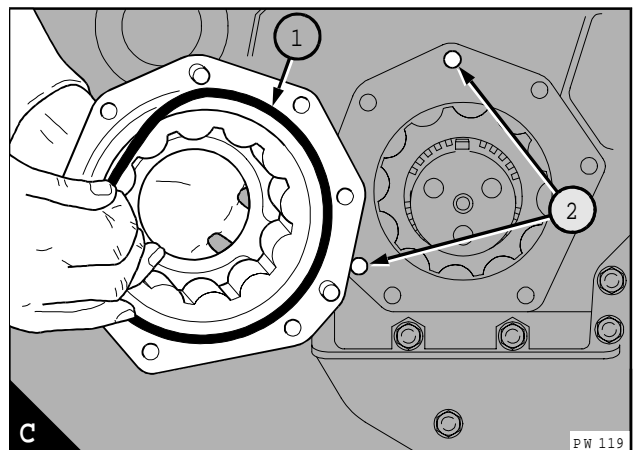
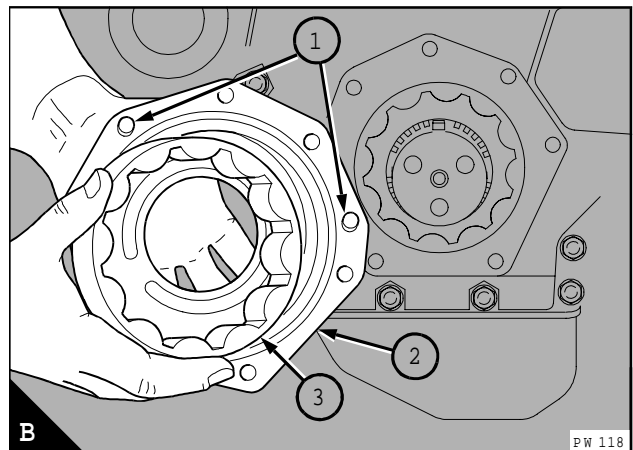
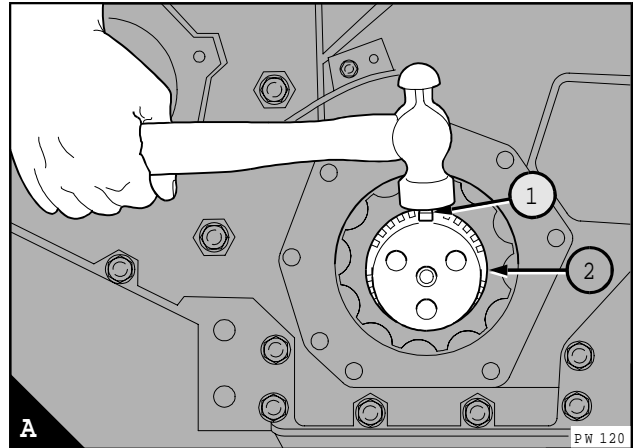

To inspect

19A-11

- 1 Remove the lubricating oil pump, [see operation 19A-10](#).
- 2 Clean all the components of the oil pump.
- 3 Visually inspect the components for damage and wear. If either the inner rotor or the outer rotor are damaged or worn they must both be renewed as an assembly.
- 4 Put the outer rotor and the inner rotor into the pump body.
- 5 Check the outer rotor to body clearance (A), [see data and dimensions](#).
- 6 Check the inner rotor end-float (B), [see data and dimensions](#).
- 7 Fit the lubricating oil pump, [see operation 19A-10](#).

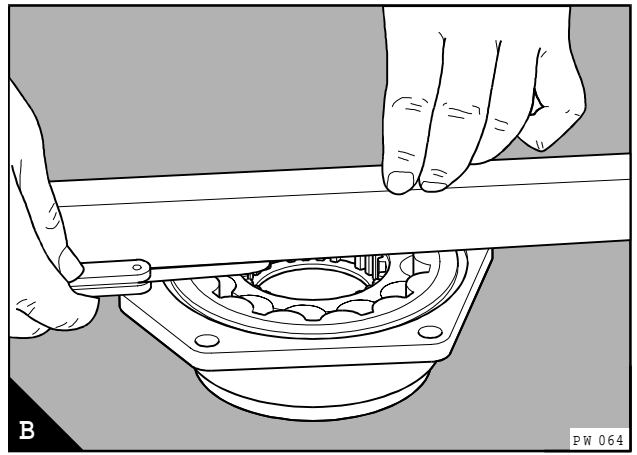
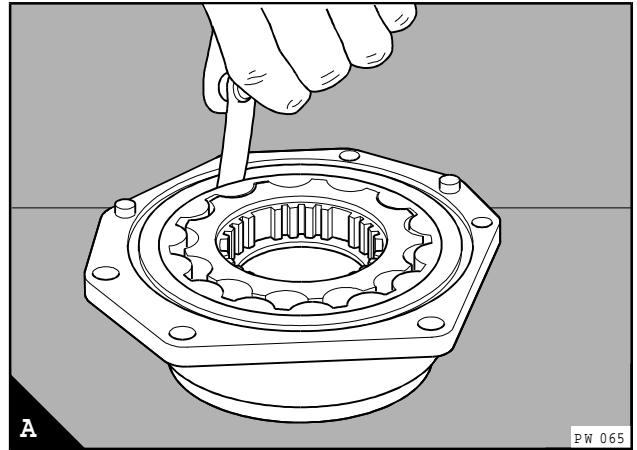

19A

Front oil seal

The front oil seal is fitted into the front of the oil pump housing.

To renew

19A-12

Special tools:

Crankshaft front oil seal replacer 21825577.

Front oil seal installer adaptor 21825953.

- 1 Remove the pulley and damper assembly, [see operation 14A-1](#).
- 2 Remove the oil seal with a suitable lever behind the main lip of the oil seal. Do not damage the edge of the oil pump housing or the crankshaft nose.
- 3 Remove the lubricating oil pump, [see operation 19A-10](#).
- 4 Use tools 21825577 and 21825953 (A2) to press (A1) a new oil seal into the oil pump housing (A3) until it is level with the front of the housing.
- 5 Fit the lubricating oil pump to the engine, [see operation 19A-10](#).
- 6 Fit the pulley and damper assembly, [see operation 14A-1](#).
- 7 Fill the lubricating system to the correct level with an approved lubricating oil.

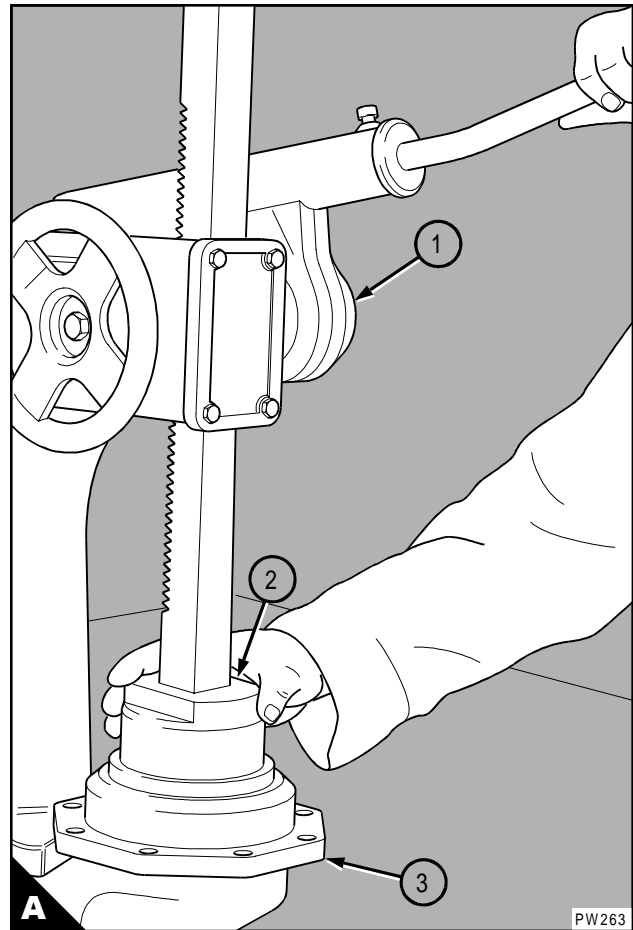

Pressure relief valve

The pressure relief valve (15A.02/A2) operates at 552 kPa (80 lbf/in²) and is fitted into the crankcase, inside the timing case.

To remove and to fit

19A-13

To remove

- 1 Remove the timing case cover, [see operation 15A-1](#).
- 2 Push the pressure relief valve open and insert a piece of copper wire into the valve. Use the copper wire to pull the valve from the crankcase.

To fit

- 1 Clean the joint faces of the timing case cover.
- 2 Fit the pressure relief valve into position in the crankcase.
- 3 Fit the timing case cover, [see operation 15A-1](#).

To inspect

19A-14

- 1 Visually inspect the valve assembly for damage.
- 2 Remove the circlip and the valve spring from the valve body.
- 3 Measure the free length of the valve springs and compare it with the data and dimensions.
- 4 Measure the spring under a load of 16,6 N (36.5 lbf) +/- 5% and compare it with the data and dimensions. If the pressure relief valve is damaged or the spring measurements are incorrect, then the pressure relief valve must be renewed.

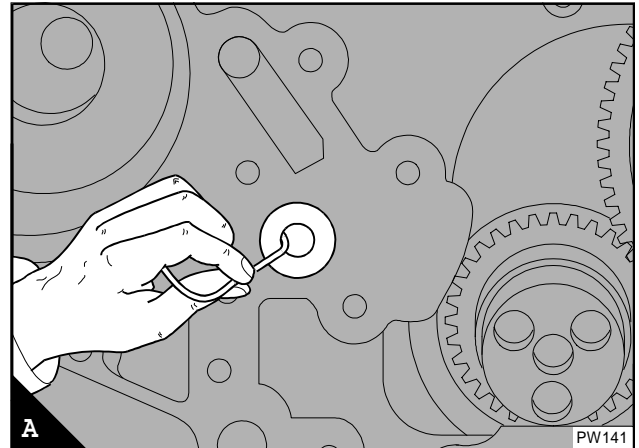

19A

Breather system

The engines have open breather systems. Breather elements are fitted inside the rocker cover assembly. The breather elements (A1) separate lubricating oil from the crankcase gases. The oil is kept inside the rocker cover (A2) and the crankcase gases pass through the breather element into an open breather pipe.

To renew the breather elements, [see operation 12A-2](#). If the breather elements are to be renewed, [see operation 12A-1](#) for special instructions to remove and to fit the rocker cover.

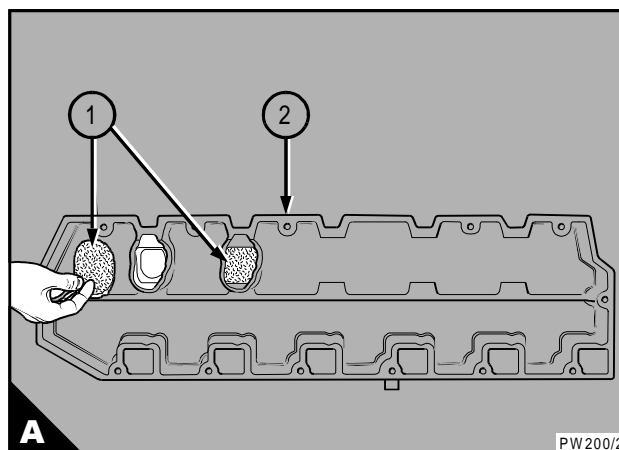

To clean

19A-15

Warning! *Do not direct compressed air at your skin.*

- 1 Remove the rocker cover, [see operation 12A-1](#).
- 2 Remove the breather elements from the rocker cover (A2). Wash the breather element (A1) and the breather pipe with an approved cleaning fluid and dry it with low pressure air.
- 3 Clean the the rocker cover with an approved cleaning fluid and dry it with low pressure air.

Data and dimensions

Note: This information is given as a guide for personnel engaged on engine overhauls. The dimensions which are shown are those which are mainly used in the factory. The information applies to all engines, unless an engine type code is shown.

Lubrication system

Minimum pressure:

- at idle and normal engine temperature..... 104 kPa (15 lbf/in²)
- at maximum no-load speed and normal engine temperature 345/497 kPa (50/72 lbf/in²)

Lubricating oil pump

- Type..... Differential rotor, the inner rotor fits into splines on the crankshaft nose.
- Radial clearance of outer rotor to body 0,470/0,622 mm (0.0185/0.0245 in)
- End float outer rotor to body 0,051/0,122 mm (0.0048/0.0020 in)
- End float of inner rotor to body 0,114/0,470 mm (0.0048/0.0020 in)

Oil pressure regulator valve

- Operating pressure 345 kPa (50 lbf/in²) 3,51 kgf/cm²
- Position In the crankcase between the oil cooler and the crankcase
- Valve spring:
- Diameter 15,24 mm (0,600 in)
- Free length 65,76 mm (2.589 in)
- Load 107 N (24.1 lbf) 11,0 kgf +/- 5%
- Length under load 39,24 mm (1.545 in)

Oil pressure relief valve

- Operating pressure 552 kPa (80 lbf/in²) 5,6 kgf/cm²
- Position In the crankcase inside the timing case
- Valve spring:
- Diameter 15,24 mm (0,600 in)
- Free length 59,9 mm (2.36 in)
- Load 162 N (36.5 lbf) 16,6 kgf +/- 5%
- Length under load 39,24 mm (1.545 in)

Oil filter

- Type..... Cannister
- By-pass valve Fitted inside the filter

Oil temperature/pressure control valve:

- Operating temperature range -54.4/148.9 °C (-65/300 °F)
- Valve closes at 104,4/115,6 °C (235/240 °F)
- Valve opens at..... 103,4/173,4 kPa (15/25 lbf/in²) 6,8/11,4 kgf/cm²
- at a temperature of 121,1 °C (250 °F)
- Valve movement from closed to open (minimum) 9,53 mm (0.375 in)

19B

Lubrication system - high-pressure

General description

Lubricating oil from the main pressure rail passes into a channel in the timing case, then into the reservoir (A1) for the high-pressure pump (A2).

The lubricating oil passes from the pump, under high-pressure, to a regulator valve (A8).

- Some oil is discharged into the timing case (A9), by the valve.
- Some oil is sent to the supply manifold (A4), then to the injector units (A3).

The high-pressure lubrication system provides the pressure to actuate the fuel injector units. The value of the oil pressure can be altered by the engine management system, this pressure is known as “injection control pressure”.

Three components work in a cycle to alter the injection control pressure:

- 1** A sensor (A5) in the supply manifold, sends a signal to the engine control module (A6).
- 2** The engine control module, uses the signal from the sensor to check the oil pressure. If the pressure needs to be altered, the module sends a signal to the solenoid (A7) of the regulator valve (A8).
- 3** The regulator valve, changes the injection control pressure.

Any change of injection control pressure, will affect the sensor, and the cycle will start again.

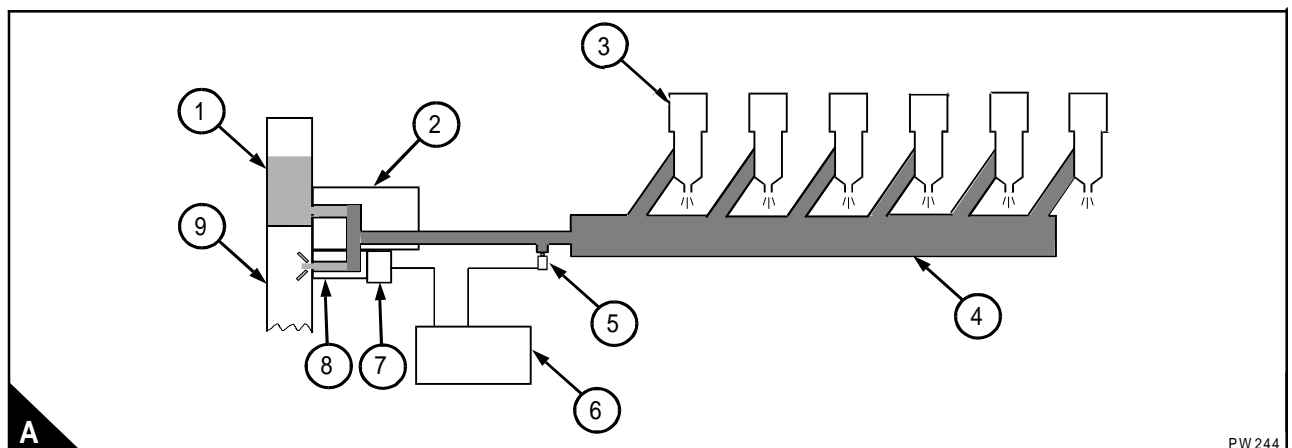

A

PW 244

Sensor for injection control pressure

The sensor for injection control pressure is of the variable capacitance type, which uses pressure to vary a voltage signal. This sensor sends its voltage signal to the engine control module, at a value between 0 volts and 5 volts.

High-pressure pump

The high-pressure pump has a drive gear, which is driven by the upper idler gear. It is a rotary pump with seven pump elements that have a constant stroke. The flow of oil from the pump will vary with engine speed.

A pressure relief valve in the body of the pump opens at 27,6 MPa (4000 lbf/in²), it discharges oil into the timing case.

Regulator valve

The regulator valve is fitted to the high pressure pump, and consists of a solenoid connected to a valve.

The solenoid receives a signal voltage from the engine control module, the value of the signal affects the amount of valve movement.

The valve changes the injection control pressure to a value between 3,5/20,7 MPa (500/3000 lbf/in²). It changes the value by discharging more, or less, oil into the timing case.

- To decrease the injection control pressure, the valve discharges more oil into the timing case, this sends less oil to the supply manifold.
- To increase injection control pressure, the valve discharges less oil into the timing case, this sends more oil to the supply manifold.

Supply manifold

The supply manifold supplies oil and fuel to the fuel injector units, through drillings. Engine oil is supplied at injection control pressure, and fuel is supplied at 241 kPa (35 lbf/in²).

Sensor for injection control pressure

To remove and to fit

19B-1

To remove

- 1 Disconnect the electrical cable at the sensor for injection control pressure.
- 2 Remove the sensor for the supply manifold and discard its 'O' ring.

To fit

- 1 Fit a new 'O' ring to the sensor.
- 2 Apply Loctite 277 to the threads of the sensor.
- 3 Fit and tighten the sensor to 26 Nm (19 lbf ft) 2,6 kgf m.

19B

High-pressure pump

To remove and to fit

19B-2

To remove

- 1 Disconnect the electrical cable (A2) at the sensor (A1) for engine oil temperature.
- 2 Disconnect the electrical cable (A4) at the solenoid (A3) of the regulator valve for injection control pressure.
- 3 Remove the banjo bolts (B2 and B4) from the fuel pipes of the lift pump, remove and discard the copper washers.
- 4 Disconnect the high-pressure oil pipe (B3).
- 5 Remove the nut (B6) which retains the solenoid (B5).
- 6 Remove the sensor for engine oil temperature.
- 7 Use a suitable pump to drain the reservoir for the high-pressure system. Drain the reservoir through the hole for the sensor (B1).
- 8 Hold the high-pressure pump, remove the two setscrews (C1) which retain the pump. Remove the pump and discard the joint.

To fit

- 1 Fit a new joint to the pump.
- 2 Align the drive gear to mesh with the lower idler gear, push the pump into the rear of the timing case. Fit and tighten the two setscrews (C1) to 27 Nm (20 lbf ft) 4,8 kgf m.
- 3 Fit the sensor (A1) for engine oil temperature and connect its electrical cable (A2).
- 4 Fit the solenoid (B5) of the regulator valve. Fit and tighten its nut (B6) to 6 Nm (4.5 lbf ft) 0,6 kgf m. Connect its electrical cable (A4).
- 5 Connect the fuel pipes to the fuel lift pump, fit new copper washers to the banjo bolts (B2 and B4). Tighten the banjo bolts to 35 Nm (26 lbf ft) 3,6 kgf m.
- 6 Fit the high-pressure oil pipe (B3).

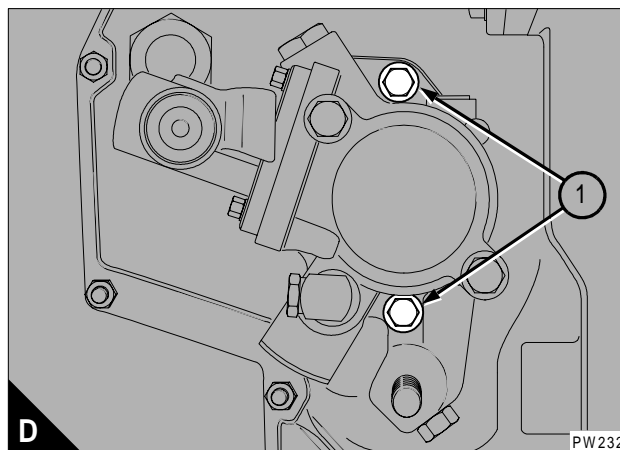
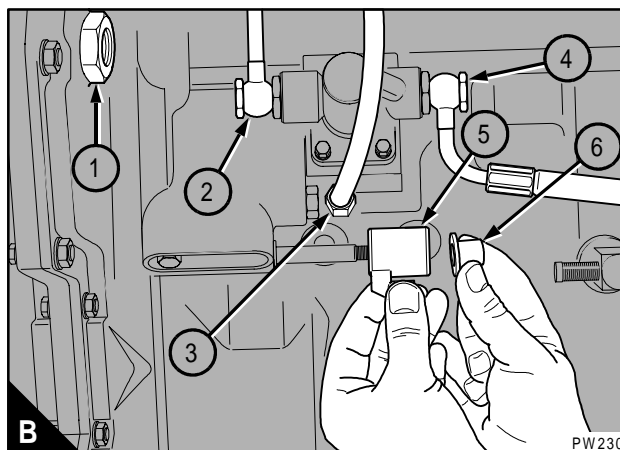
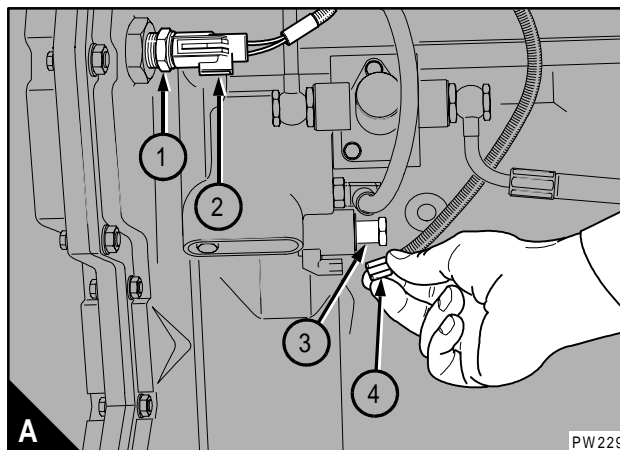

Regulator valve for injection control pressure

To remove and to fit

19B-3

To remove

- 1 Disconnect the electrical cable (A2) at the sensor (A1) for engine oil temperature.
- 2 Disconnect the electrical cable (A4) at the solenoid (A3) of the regulator valve for injection control pressure.
- 3 Remove the sensor.
- 4 Use a suitable pump to drain the reservoir for the high-pressure system. Drain the reservoir through the hole for the sensor (B1).
- 5 Remove the nut (B3) which retains the solenoid (B2).
- 6 Remove the regulator valve (B4).

To fit

- 1 Fit and tighten the regulator valve (B4) to 47 Nm (35 lbf ft) 4,8 kgf m.
- 2 Fit the solenoid (B2) of the regulator valve. Fit and tighten its nut (B3) to 6 Nm (4.5 lbf ft) 0,6 kgf m. Connect its electrical cable (A4).
- 3 Fit the sensor for engine oil temperature and connect its electrical cable (A2).

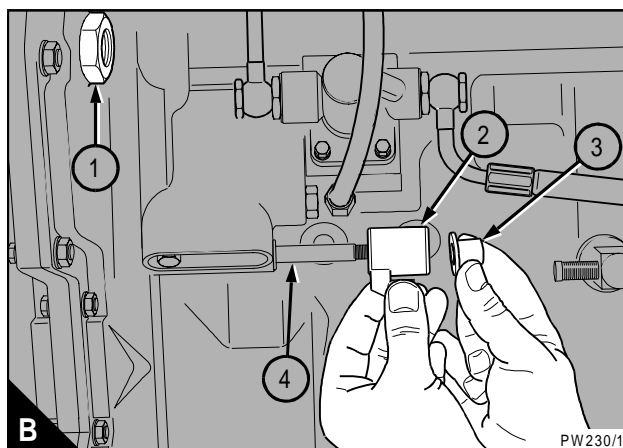
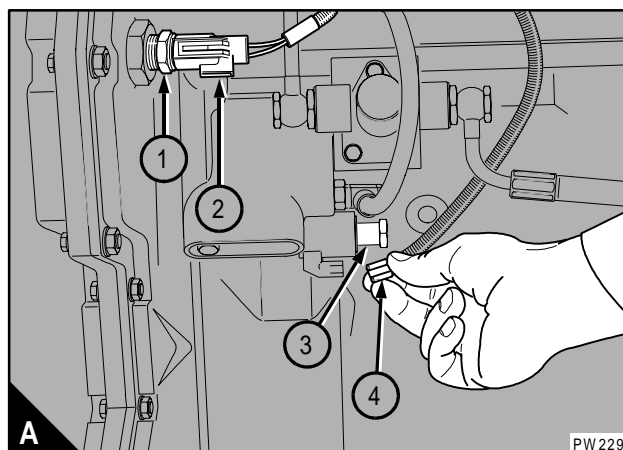

19B

Supply manifold

To remove and to fit

19B-4

To remove

- 1 Put a container of approximately 2 litres (4 pints) under the drain plug (B2) for the supply manifold.
- 2 Remove the banjo bolt of the fuel return pipe (A3), and disconnect the banjo union (A2). Discard the copper washers.
- 3 Remove the valve (A1) for the fuel return pipe.
- 4 Remove the plug (B2) and drain the lubricating oil from the gallery in the supply manifold (B3). Remove and discard the 'O' ring (B1).
- 5 Remove the container and discard the fluids safely in accordance with local regulations.
- 6 Disconnect the high-pressure oil pipe (C1) at the supply manifold (C3).
- 7 Disconnect the fuel pipe (C2) at the supply manifold. Discard the copper washers.
- 8 Remove the 12 setscrews which retain the supply manifold, remove the manifold. Remove and discard the joint.

To fit

- 1 Fit the supply manifold, together with a new joint. Fit and tighten the setscrews to 27 Nm (20 lbf ft) 2,8 kgf m.
- Caution:** Ensure that the word "FRONT" on the joint is facing toward the supply manifold.
- 2 Fit the fuel pipe (C2) at the supply manifold (C3), together with new copper washers.
 - 3 Fit the high-pressure oil pipe (C1).
 - 4 Fit the drain plug (B2), together with a new 'O' ring (B1).
 - 5 Fit the valve (A1) for the fuel return pipe.
 - 6 Connect the banjo union (B2) of the fuel return pipe, together with new copper washers. Fit and tighten the banjo bolt (B3) to 35 Nm (26 lbf ft) 3,5 kgf m.
 - 7 Eliminate air from the fuel system, [see operation 20A-7](#).

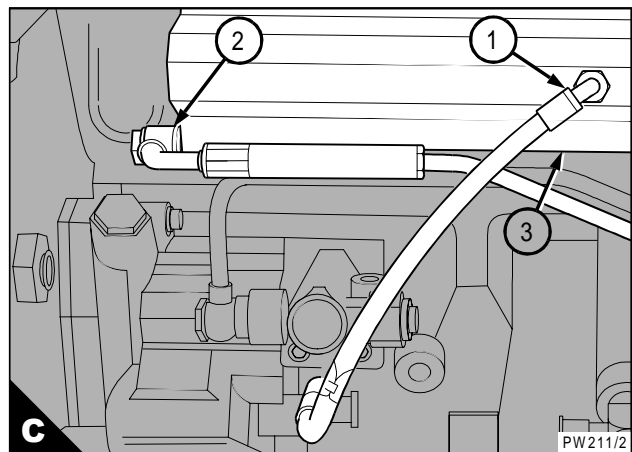
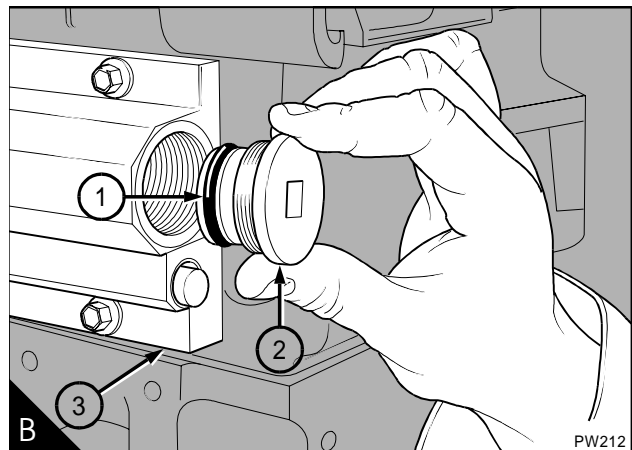
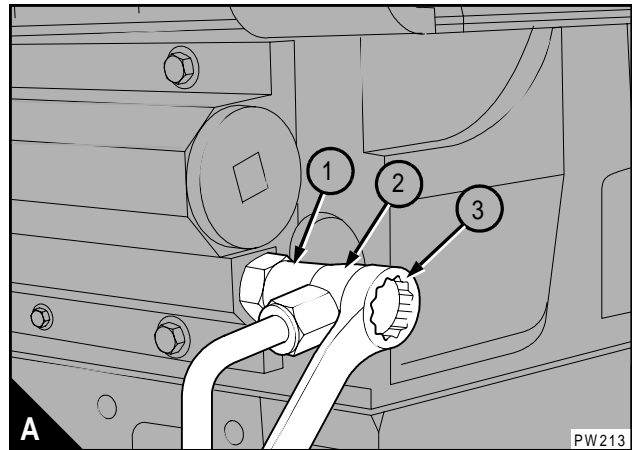

Data and dimensions

Note: This information is given as a guide for personnel engaged on engine overhauls. The dimensions which are shown are those which are mainly used in the factory. The information applies to all engines, unless an engine type code is shown.

Pump gear

Backlash 0,140/0,256 mm (0.0055/0.0101 in)

End-float 0,45/1,22 mm (0.018/0.48 in)

Sensor for injection control pressure

Operating temperature range -40 °C to 125 °C (-40 °F to 257 °F)

Maximum flow rate 17,5 litres/min (4.52 Gal/min)

Maximum operating pressure 20,7 MPa (3000 lbf/in²)

20A

Fuel system

General description

Fuel from the tank normally passes through a pre-filter and a pipe to the fuel strainer (A5). The fuel passes from the strainer, through a passage in the filter head (A4), then through a pipe to the lift pump (A7). From the lift pump fuel passes, under pressure, through a pipe and through the filter head to the filter canister (A6).

Clean fuel leaves the filter canister and returns to the filter head, then passes through a pipe to a gallery in the supply manifold (A2). A valve (A3) in the supply manifold operates at 241 kPa (35 lb/in²) and allows fuel to return to the fuel tank, through a pipe.

Fuel from the supply manifold passes through passages in the cylinder head, to the fuel injector units (A1). The injector unit increases the pressure of the fuel to 24/124 MPa (3500/18000 lbf/in²), and atomised fuel is injected into the cylinder.

Cautions:

- It is very important that dirt does not enter the fuel system. Before a connection is disconnected, clean thoroughly the area around the connection. After the component has been disconnected, fit a suitable cover to all open connections.
- The fuel injection equipment must only be checked and adjusted by personnel who have had the correct training.

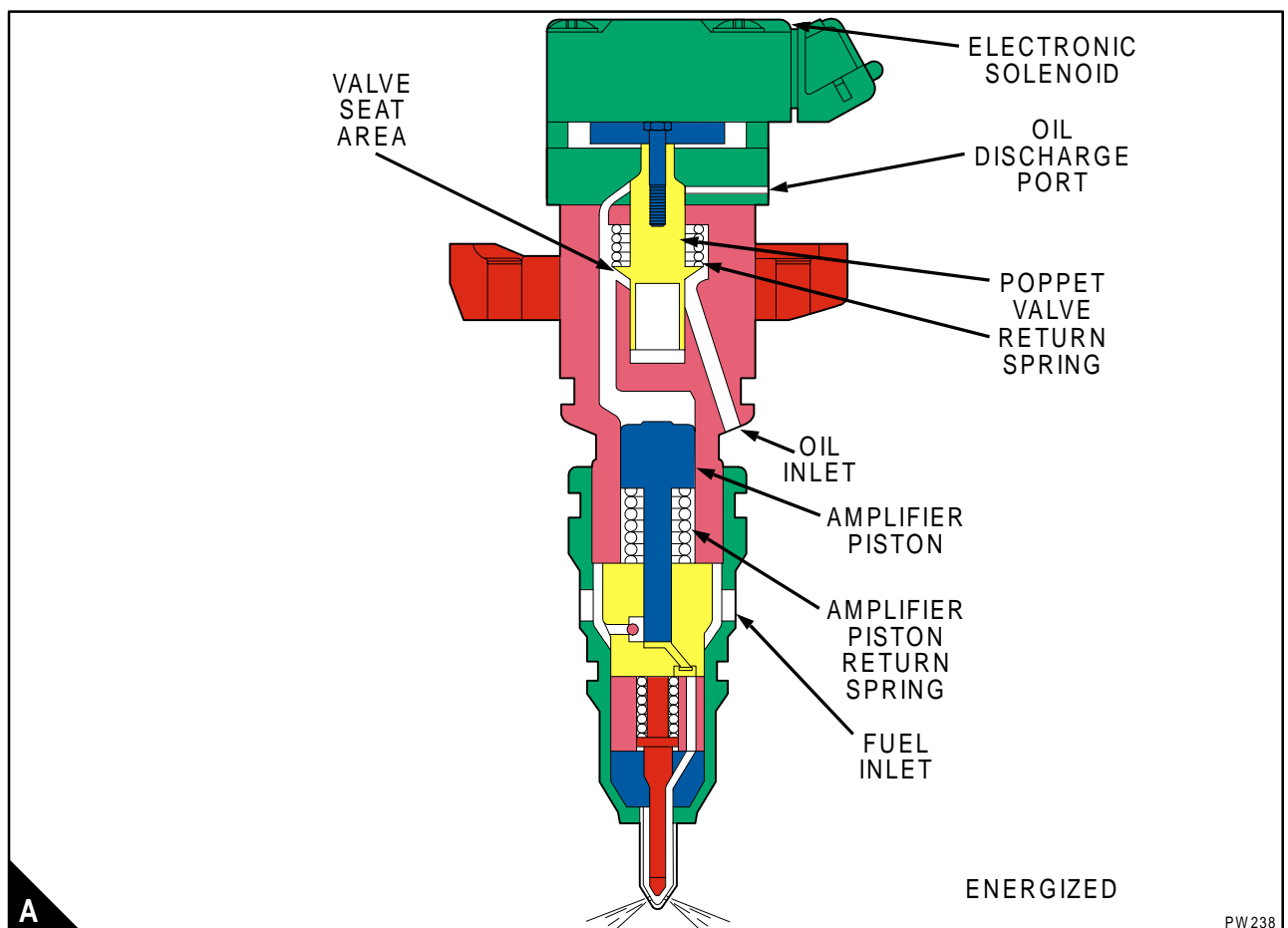

Fuel injector units

The fuel injector units are controlled electronically by the engine control module, with a pulse of 110 volts, to a solenoid.

The units are actuated by engine lubricating oil from the high-pressure system.

The value of the oil pressure can be altered by the engine management system, this pressure is known as "injection control pressure".

The injector unit has two main chambers: the oil chamber and the fuel chamber.

The oil chamber receives engine oil from the supply manifold at injection control pressure. A valve, which is connected to the armature of the solenoid, controls the flow of oil through the oil chamber.

- When the solenoid is energised, the valve closes an outlet port and opens an inlet port.
- When the solenoid is de-energised, the valve opens the outlet port and closes the inlet port.

The fuel chamber receives fuel at supply pressure from the supply manifold. A ball-valve and a flat-valve control the flow of fuel through the chamber.

There are three phases of injection:

- 1 Injection
- 2 End-of-injection.
- 3 Fill

These occur during the two strokes of the piston (A3).

- The injection phase occurs during the down stroke of the piston.
- The end-of-injection phase and the fill phase occur during the up stroke of the piston.

Note: See opposite page for illustrations.

Phase 1: Injection

An electrical pulse from the engine control module energises the solenoid (A1). The armature (A2) of the solenoid pulls the valve (A3) against the pressure of the spring (A6), to close the outlet port (A5), and to open the inlet port (A7). This allows engine oil at injection control pressure to enter the oil chamber (A4).

The oil pressure above the piston is now greater than the total pressure of the spring (A9) and the fuel below the piston (A8), this causes the piston to move down into the fuel chamber (A10).

Note: The surface area of the top of the piston is six or seven times greater than the surface area of the bottom of the piston. This difference gives a mechanical advantage. The mechanical advantage is 6:1 for WK and WL engines, and is 7:1 for WM and WN engines. An increase of pressure in the oil chamber causes an increase of pressure in the fuel chamber that is six or seven times greater.

As the piston moves down into the fuel chamber, the pressure of the fuel below the piston increases. When this pressure is greater than the supply pressure (B3), the ball-valve (B4) in the fuel chamber closes. This prevents the entry of more fuel into the chamber.

When the ball-valve closes, the pressure in the fuel chamber rises rapidly and the flat valve (B5) opens to allow the high-pressure into the nozzle (B6) of the injector unit.

As the piston continues to move down, more oil enters the oil chamber and the pressure in the fuel chamber continues to increase. When the fuel reaches injection pressure, the nozzle needle (B2) is pushed up from its seat, against the pressure of the spring (B1), and injection begins.

The period of injection is controlled by the engine control module.

Phase 2: End-of-injection

The engine control module de-energises the solenoid to start the end-of-injection.

When the solenoid is de-energised, the pressure of the spring (C4) moves the valve up, this closes the oil inlet port (C5), and opens the oil outlet port (C3). The oil chamber is now closed to oil at injection control pressure and the oil pressure in the chamber is allowed to discharge through the outlet port into the rocker cover.

When the pressure in the oil chamber is less than the total pressure of the spring (C6) and the fuel in the fuel chamber, the piston moves up into the oil chamber.

When the piston moves up, the pressure of the fuel in the fuel chamber reduces rapidly. This causes the flat valve to close. As the piston continues to move up, the fuel pressure above the flat-valve becomes less than the fuel pressure below it and the valve is kept closed.

The initial rapid reduction of pressure in the fuel chamber allows the spring (D1) to close the nozzle needle. As soon as the nozzle needle closes it fills more space in the nozzle, which causes the pressure below the flat valve to increase rapidly. This opens the nozzle needle again and a small amount of fuel is injected, then the pressure reduces again and the nozzle needle closes. Fuel injection ends.

Phase 3: Fill

When the piston moves up during the end-of-injection phase, the pressure in the fuel chamber (D3) reduces. When this pressure is less than supply pressure (D2), the ball valve opens, and fuel is allowed to fill the fuel chamber through holes in the side of the injector unit. The flat-valve is closed by the pressure of the fuel below it.

Key to the colours of the illustrations opposite:

Green = Lubricating oil at injection control pressure

Blue = Lubricating oil at discharge pressure

Yellow = Fuel at supply pressure

Red = Fuel at injection pressure.

Grey = A moving component, the direction of movement is shown by an arrow on the component.

Fuel filter

Fuel pre-filter

This will normally be fitted between the fuel tank and the engine. Check the filter bowl for water at regular intervals and drain as necessary. Refer to the User's Handbook for the correct service intervals.

To renew the fuel strainer and the canister of the fuel filter

20A-1

Caution: *It is important that only the genuine Perkins parts are used. The use of wrong parts could damage the fuel injection pump.*

Note: The fuel filter assembly has a fuel strainer to remove the larger particles from the fuel and a filter canister to remove the smaller particles. The fuel strainer and the filter canister should be renewed at the same time.

- 1 Thoroughly clean the outside surfaces of the fuel filter assembly.
- 2 Use a strap wrench or similar tool to loosen the filter canister, and remove the canister.
- 3 Use a 29 mm (1.1/8 in) socket spanner to remove the plastic cover (A5) from the fuel strainer. Remove the strainer (A3) and the 'O' ring (A4) from the cover.
- 4 Fit a new strainer and a new 'O' ring to the cover and fit the cover to the filter head.

Caution: *Ensure that the open end of the new strainer is toward the filter head.*

5 Ensure that the threaded adaptor (A1) is secure in the filter head and that the inside of the head is clean. Lubricate lightly the seal (A2) of the new canister with clean diesel fuel. Fit the new canister to the filter head and tighten the canister by hand until the seal contacts the filter head. Tighten the canister a further 1/2 turn by hand only. Do not use a strap wrench.

6 Eliminate the air from the fuel filter, [see operation 20A-7](#).

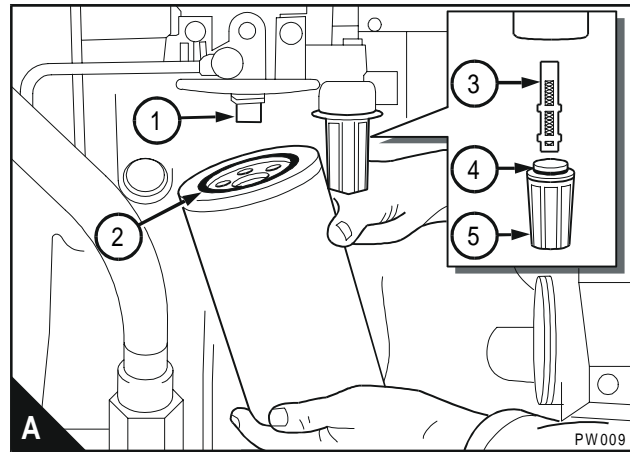

Fuel injector units

A fuel injector unit fault can cause an engine misfire.

Cautions:

- *Special equipment is necessary to test the fuel injector units. This equipment is available at Perkins distributors.*
- *Fuel injector units should be removed by a person who has had the correct training. If the correct procedure is not used, the cylinders of the engine will be filled with fuel and engine lubricating oil.*

The fuel injector units are controlled by the engine management system which cannot be adjusted by the operator.

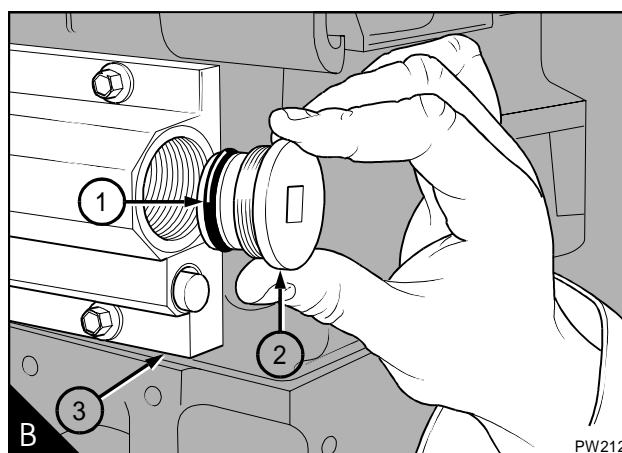
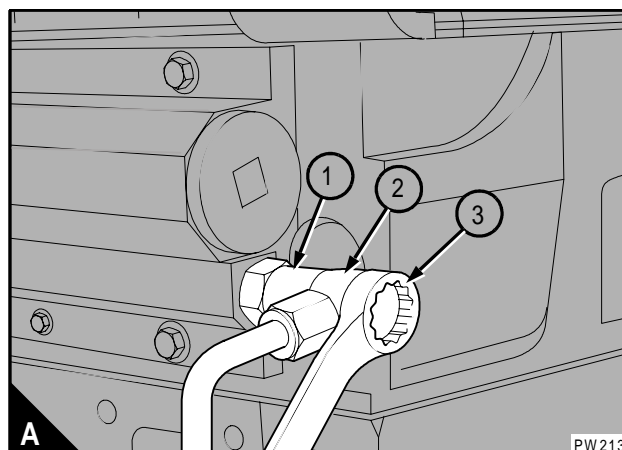

To renew an injector unit

20A-2

To remove

- 1 Drain the cooling system
- 2 Put a container of approximately 2 litres (4 pints) under the drain plug (B2) for the supply manifold.
- 3 Remove the banjo bolt (A3) of the fuel return pipe, and disconnect the banjo union (A2). Discard the copper washers.
- 4 Remove the valve (A1) for the fuel return pipe and drain the fuel from the gallery in the supply manifold (B3).
- 5 Remove the plug (B2) and drain the lubricating oil from the gallery in the supply manifold. Remove and discard the 'O' ring (B1).
- 6 Remove the container and dispose of the fluids safely in accordance with local regulations.
- 7 Remove the rocker cover, [see operation 12A-1](#).
- 8 Remove the screws which retain the plate for the electrical cables, and remove the plate (C).

Continued

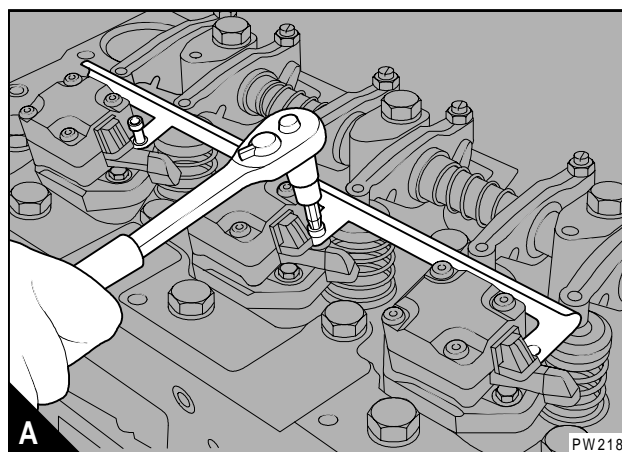

20A

9 Remove the rear setscrew (A) from the clamp which retains the injector unit.

Caution: Do not remove the front setscrew (B), it is not necessary to do so.

10 Tilt the clamp (C) until it is free from the front setscrew.

11 Push the clamp toward the front of the engine (D).

Continued

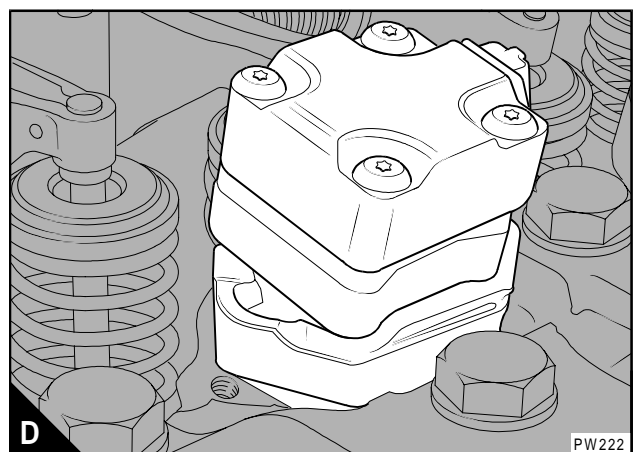
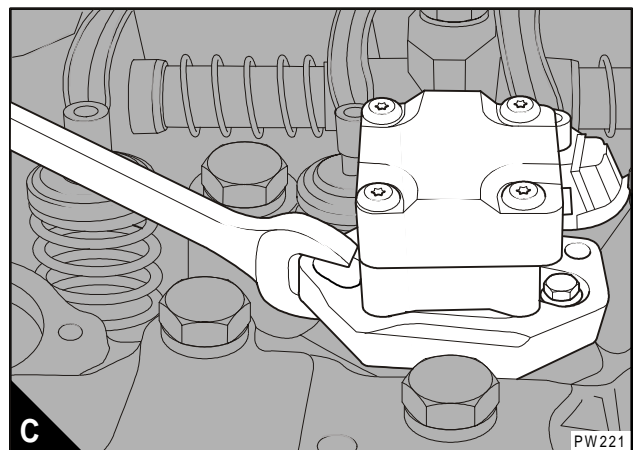
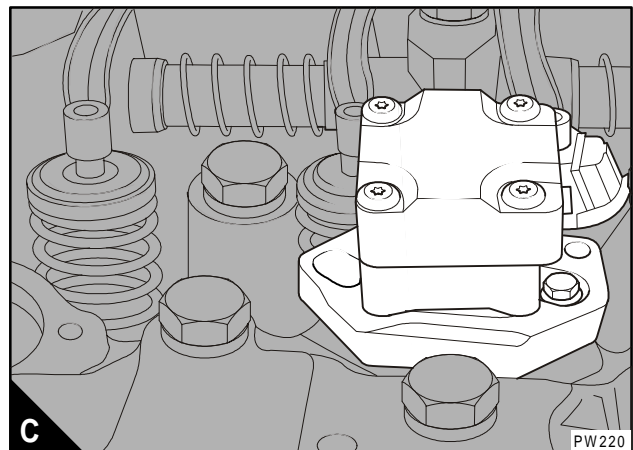
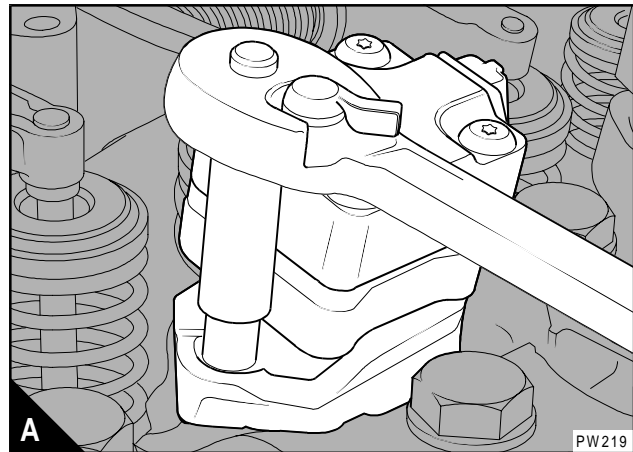

- 12 Use a lever (A) to carefully raise the injector unit.
- 13 Remove the injector unit. Remove and discard the 'O' rings and the copper washer (20A.11/A).

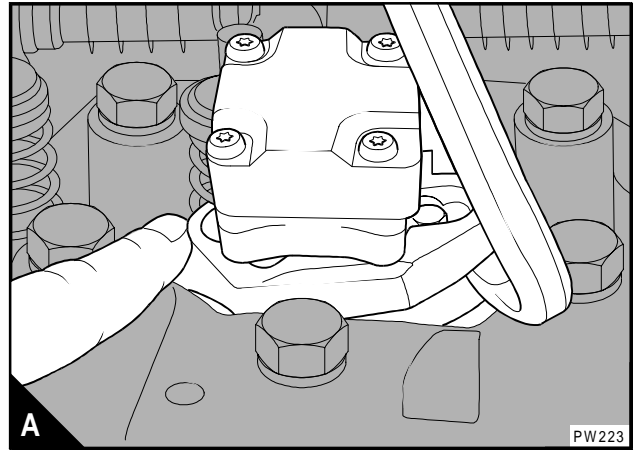

20A

To fit

- 1 Renew the injector unit seals and copper washer, see operation 20A-3.
- 2 Carefully insert the injector unit into its sleeve; ensure that the clamp (A1) is aligned to allow the front setscrew (A2) to pass through it.
- 3 Push the injector unit down (A) until it is on its seat.
- 4 Tilt the clamp (B) until it is past the head of the setscrew.
- 5 Push the clamp backward (C) until it engages the front setscrew and aligns with the hole for the rear setscrew.
- 6 Fit the rear setscrew (D) and tighten it to 30 Nm (120 lbf ft) 3,0 kgf m.

Continued

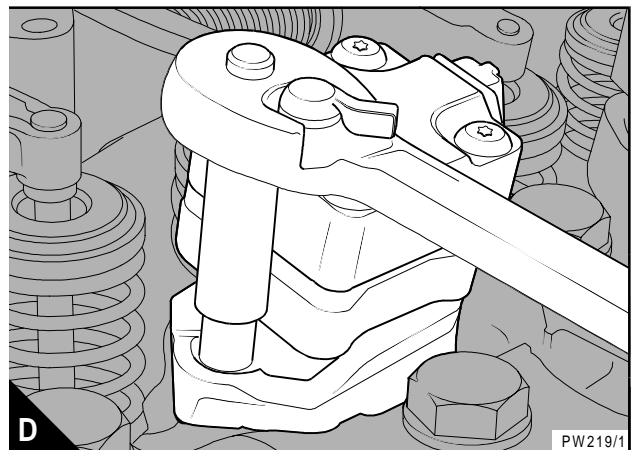
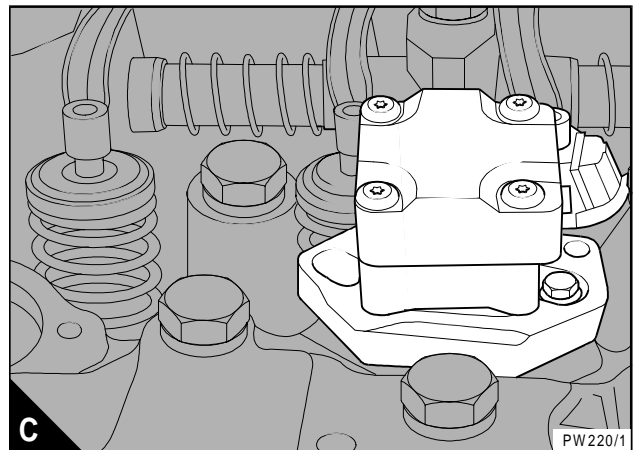
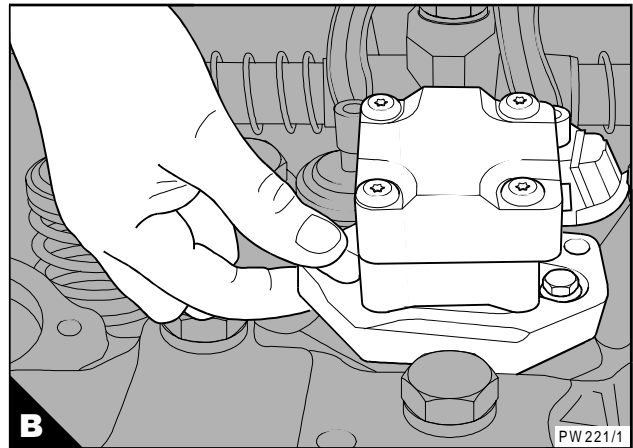
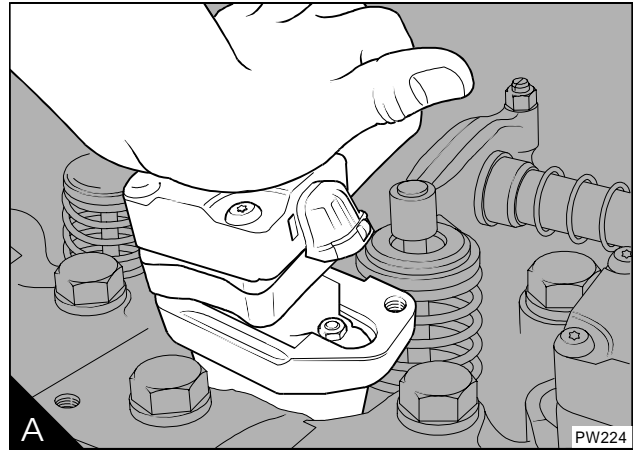

- 7 Fit the plate for the injector unit cables (A).
- 8 Fit the rocker cover, [see operation 12A-1](#).
- 9 Fit a new 'O' ring (B1) to the drain plug and fit the plug (B2) into the gallery in the supply manifold (B3).
- 10 Fit the valve (C1) for the fuel return pipe and tighten it to 35 Nm (26 lb ft) 3,6 fgf m.
- 11 Fit new copper washers to the banjo union (C3) of the fuel return pipe, fit and tighten the banjo bolt (C2) to 35 Nm (26 lb ft) 3,6 fgf m.
- 12 Fill the cooling system.
- 13 Eliminate air from the fuel system, [see operation 20A-7](#).

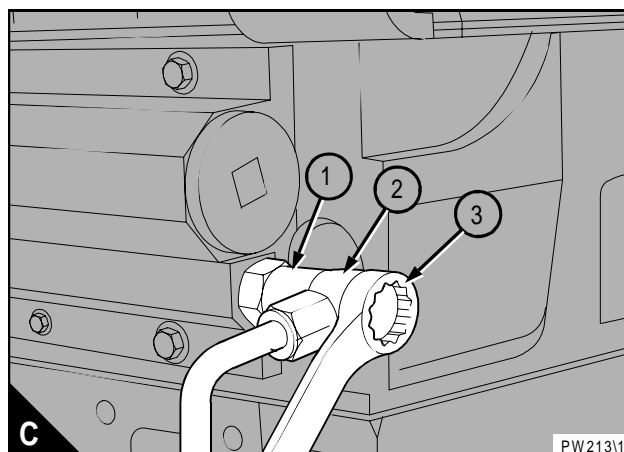
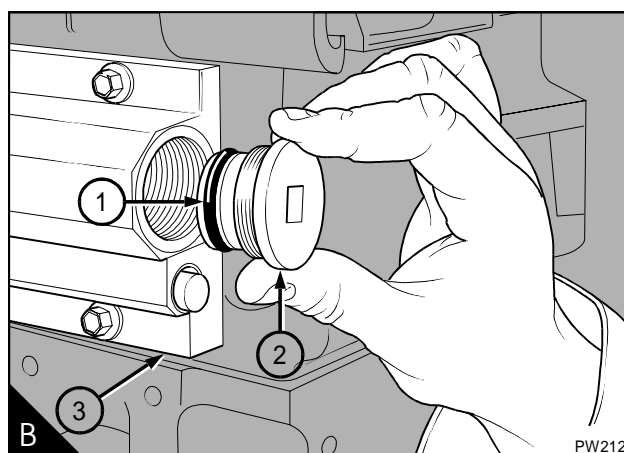
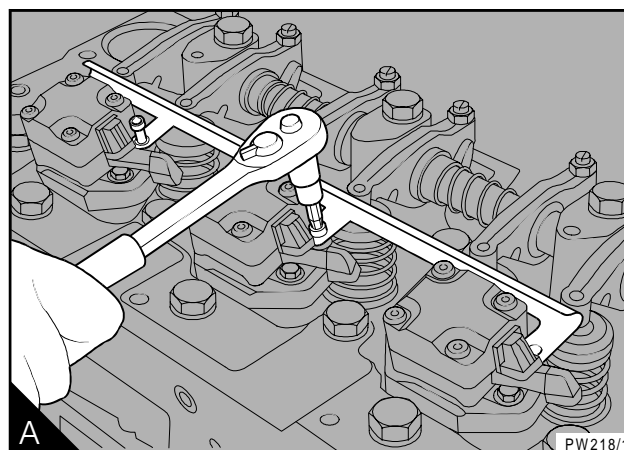

Special tools:

Sleeve 27610095

Fit the new seals to the injector unit in the sequence shown below.

- 1 Fit the special tool 27610095 over the injector unit.
- 2 Fit the split ring (A1) into its groove.
- 3 Lift the tool slightly and slide the rubber ring (A2) over the tool until it fits into its groove in the injector unit.
- 4 Lift the tool slightly and roll the 'O' ring (A3) over the tool until it fits into its groove in the injector unit.
- 5 Lift the tool until it aligns with the next seal groove.
- 6 Roll the 'O' ring (A4) over the tool until it fits into its groove in the injector unit.
- 7 Lift the tool slightly, slide the rubber ring (A5) over the tool until it fits into its groove in the injector unit.
- 8 Remove the tool from the injector unit.
- 9 Roll the 'O' ring (A6) over the injector unit until it fits into its groove.
- 10 Fit the copper washer (A7) to the injector unit

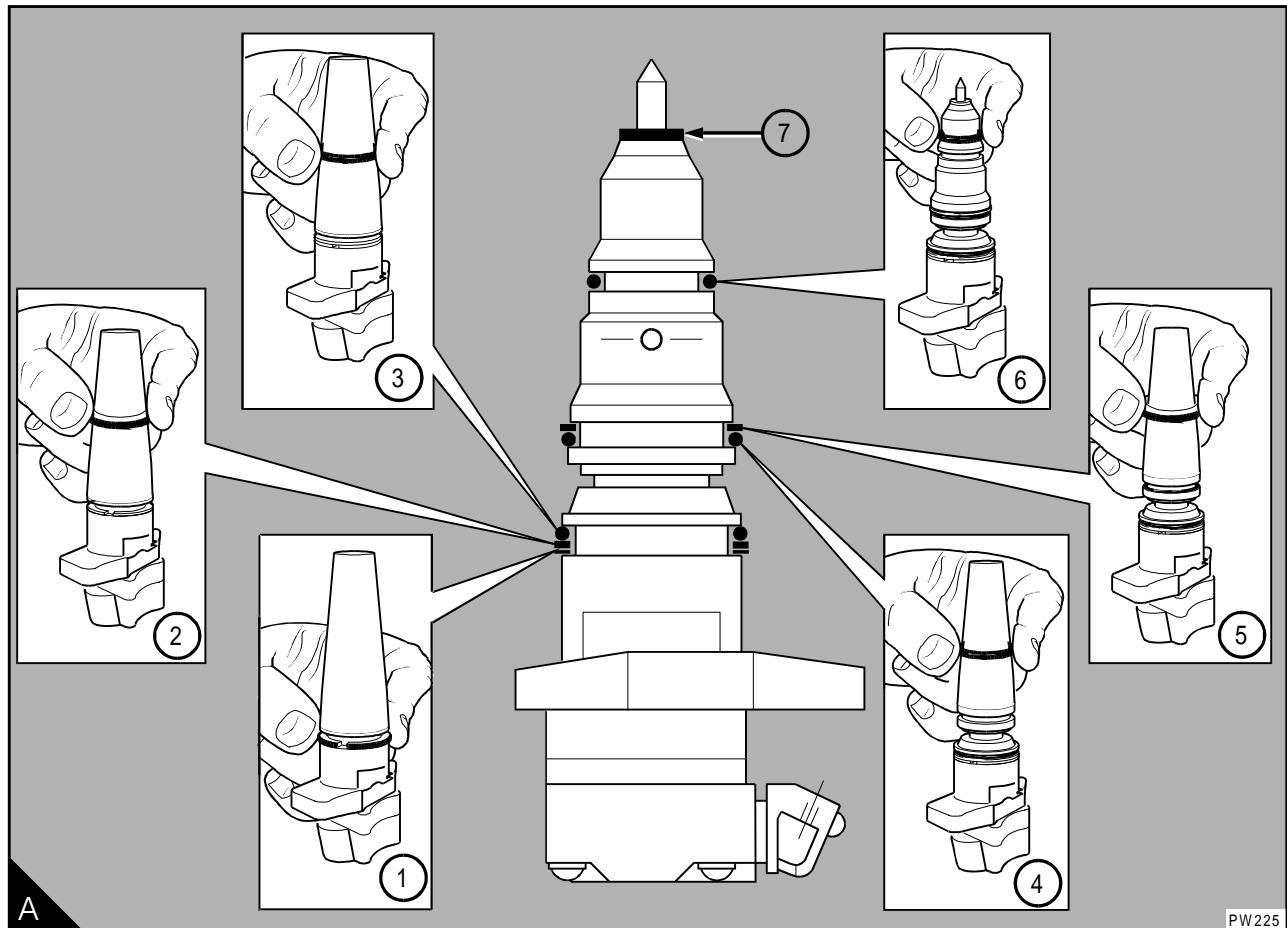

Fuel lift pump

Note: The fuel lift pump is fitted to the side of the high-pressure pump.

To remove and to fit

20A-4

To remove

- 1 Remove the banjo bolts (A1 and A5) from the fuel pipes and discard the washers (A2 and A4).
- 2 Release the nuts (A3) and remove the pump (A6).
- 3 Remove and discard the joint.

To fit

- 1 Clean the joint face on the fuel lift pump and on the high-pressure pump.

Note: Ensure that the eccentric on the camshaft of the high-pressure pump is in the minimum lift position. If it is not, rotate the crankshaft until it is.

- 2 Fit a new joint to the lift pump.
- 3 Check that the push rod (20A.13/A12) is in position and fit the lift pump to the high-pressure pump.
- 4 Fit and tighten the nuts (A3) gradually and evenly to 6 Nm (4 lbf ft) 0,6 kgf m.
- 5 Connect the fuel pipes to the fuel lift pump, fit new copper washers (A2 and A4) to the banjo bolts (A1 and A5). Tighten the banjo bolts to 35 Nm (26 lbf ft) 3,6 kgf m.

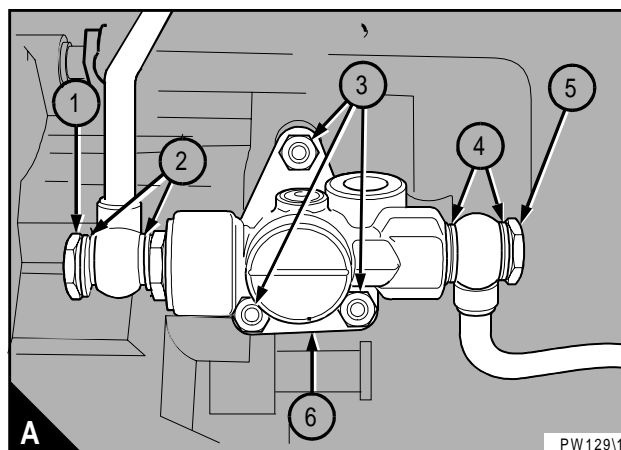

To dismantle

- 1 Clean the outside surfaces of the fuel lift pump.
- 2 Remove the lift pump from the high-pressure pump, see operation 20A-4.
- 3 Remove the push rod (A12).
- 4 Remove the end nut (A10).
- 5 Remove and discard the 'O' ring (A9) from the end nut.
- 6 Remove and discard the small 'O' ring (A11) from inside the end nut.
- 7 Remove the plunger (A8) the suction valve (A7) the spring seat washer (A6) the spring (A5) and the second spring seat washer (A4) from the pump body (A1).
- 8 Remove the delivery valve assembly (A3) from the body.
- 9 Remove and discard the 'O' ring (A2) from the delivery valve assembly.

To assemble

- 1 Thoroughly clean inside the body of the lift pump and ensure that the passages in the body are not restricted.
- 2 Carefully clean the valves in clean diesel fuel. Inspect each valve for damage to the valve spring and the valve plate. If there is damage, renew the valve.
- 3 Put a spring seat washer (A4) in position in the pump body (A1). Ensure that the flat face of the washer is toward the bottom of the body.
- 4 Put the spring (A5) on the spring seat washer and the other spring seat washer (A6) on the spring.
- 5 Put the suction valve (A7) in position on top of the valve seat washer. Ensure that the large diameter of the valve is toward the spring seat washer.
- 6 Put the plunger (A8) in position in the pump body over the valve and spring.
- 7 Renew the 'O' ring (A11) which fits inside the end nut (A10) and renew the 'O' ring (A9) on the outside of the end nut.
- 8 Support the pump body, put the end nut in position on the plunger. Compress the spring and engage the threads of the end nut with the threads in the pump body. Tighten the end nut to 42 Nm (31 lbf ft) 4,3 kgf m.
- 9 Put the push rod (A12) in position in the end nut.
- 10 Put a new 'O' ring (A2) on the delivery valve assembly (A3).
- 11 Fit the deliver valve assembly and tighten to 42 Nm (31 lbf ft) 4,3 kgf m.

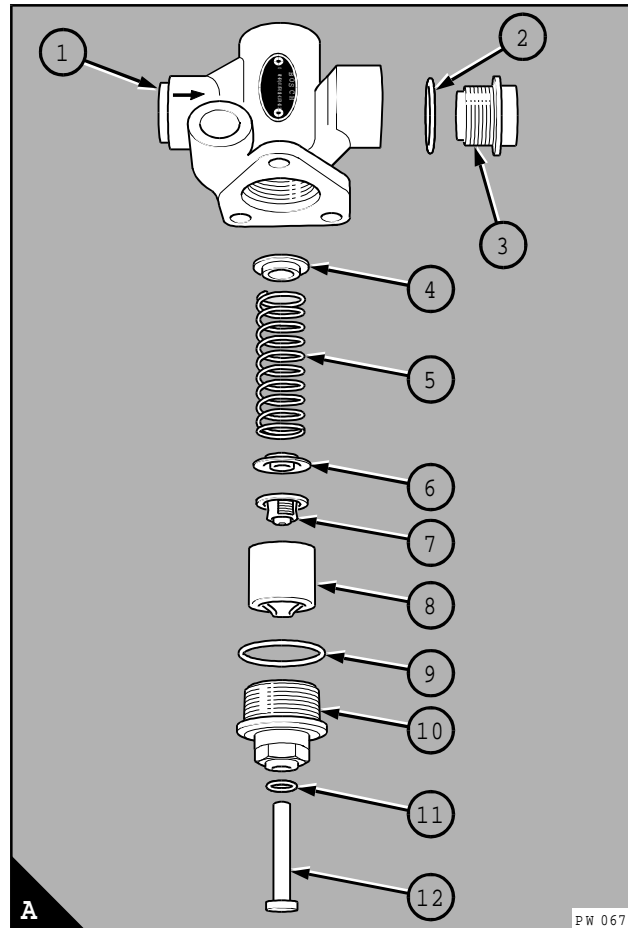

To set the adjustment of the speed control

20A-6

Special equipment is necessary to set the idle speed and the maximum no load speed. If further information is required, contact the Service Department of Perkins International Limited at Peterborough.

20A

To eliminate air from the fuel system

20A-7

If air enters the fuel system, it must be eliminated before the engine can be started.

Air can enter the system if:

- The fuel tank is drained during normal operation.
- The low-pressure fuel pipes are disconnected.
- A part of the low-pressure fuel system leaks during engine operation.

In order to eliminate air from the fuel system, proceed as follows:

- 1 Loosen the vent plug (A1) on the top of the fuel filter head.
- 2 Operate the plunger of the fuel priming pump (A2) until fuel, free from air, comes from the filter vent point. Tighten the vent plug.
- 3 Turn the start key to the "ON" position.
- 4 Operate the starter motor for intervals of 15 seconds until the engine starts. If the engine runs correctly for a short time and then stops or runs roughly, check for air in the fuel system. If there is air in the fuel system, there is probably a leakage in the low pressure system. Turn the start key to the "OFF" position to stop the engine. Correct the leakage and repeat the procedure.

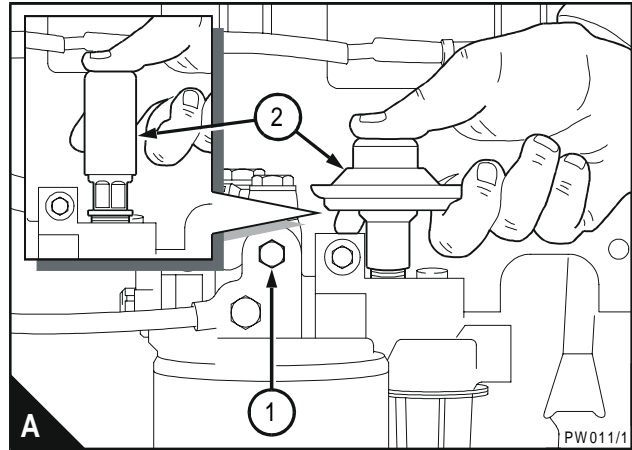

Data and dimensions

This information is given as a guide for personnel engaged on engine overhauls. The dimensions which are shown are those which are mainly used in the factory. The information applies to all engines, unless an engine type code is shown.

Fuel filter

Type..... Canister and strainer

Nozzles

Type..... Multi hole

Opening pressure 24/124 MPa (3500/18000 lbs/in²)

Valve (fitted in the supply manifold)

Opening pressure 241 kPa (35 lb/in²)

21A

Cooling system

This page has been
left blank intentionally

General description

Coolant from the bottom of the radiator passes along a channel in the timing case to the centrifugal coolant pump, which is fitted on the front of the timing case. The pump is belt driven and assists the flow of the coolant through the system. The coolant passes along another channel in the timing case to a passage in the cylinder block. An equal amount of coolant passes to the bottom of each cylinder liner at an angle. This angle causes the coolant to move around and up the cylinder liners. The movement of the coolant helps to cool the cylinders. The coolant leaves the cylinder head at the front and passes into the thermostat housing. If the thermostat is closed, the coolant goes directly through a by-pass to the inlet side of the coolant pump; if the thermostat is open, the by-pass is closed and the coolant passes to the top of the radiator.

From the cylinder block, coolant also passes through the oil cooler to the inlet side of the coolant pump.

From the cylinder block, coolant also passes through the air compressor, if one is fitted.

A coolant filter is fitted to the rear of the timing case. Ports in the coolant channels in the timing case allow 3% to 10% of the coolant to pass through the filter. Non-return valves control the direction of coolant flow from the outlet side side of the coolant pump, through the filter to the inlet side of the pump. The filter contains a special inhibitor which helps to prevent corrosion in the cooling system.

A tensioner pulley automatically maintains the correct tension of the drive belt.

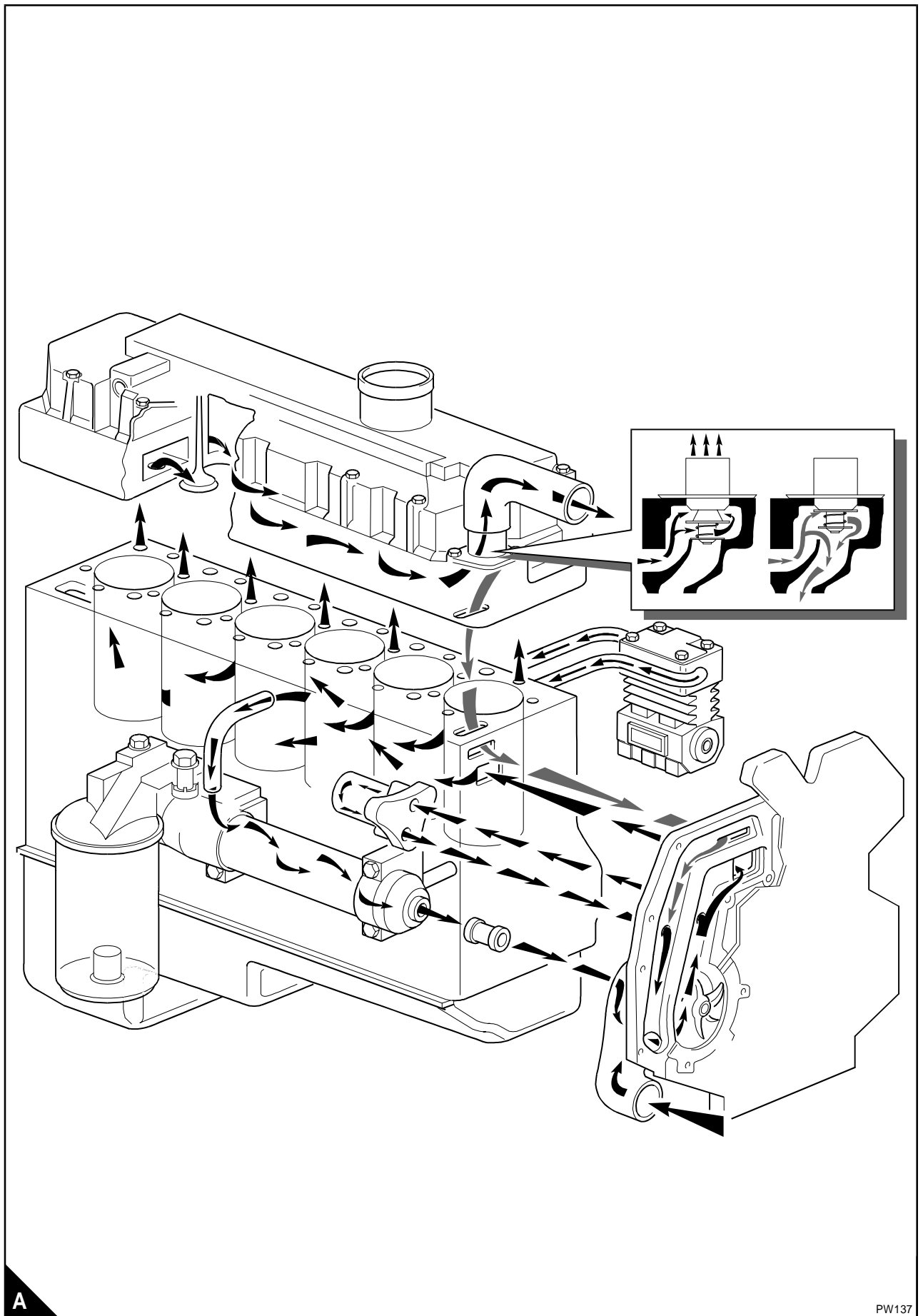

A

PW137

21A

To renew the canister of the coolant filter/ inhibitor

21A-1

Warning! Do not remove the canister while the engine is still hot and under pressure because dangerous hot fluid can be discharged.

Caution: The canister contains a corrosion inhibitor which is circulated around the cooling system as the coolant passes through the canister. It is important that only the genuine correct Perkins canister is used.

1 When the engine has cooled, remove the radiator filler cap to release the system pressure.

Note: When the system pressure is released, valves will close in the filter canister and in the housing for the canister. This will prevent the loss of coolant when the filter is removed.

2 Thoroughly clean the outside surfaces of the coolant filter assembly.

3 Use a strap wrench or similar tool to loosen the filter canister and remove the canister. Valves in the filter head will prevent the loss of coolant when the canister is removed.

4 Ensure that the threaded adaptor (A2) is secure in the filter head and that the inside of the head is clean.

5 Lubricate lightly the seal (A1) on top of the new canister with clean engine coolant. Fit the new canister to the filter head and tighten, by hand only. Do not overtighten the canister.

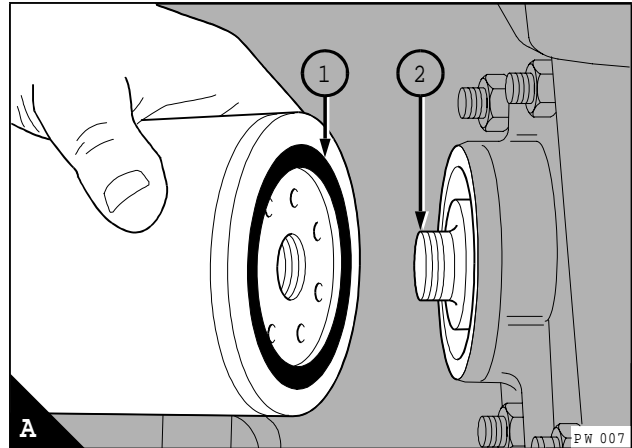

Thermostat

To remove and to fit

21A-2

To remove

- 1 Drain the cooling system so that the coolant level is below the thermostat position and disconnect the top hose from the water outlet connection.
- 2 Release the setscrews and remove the thermostat assembly (A). Discard the 'O' ring (A1).

To fit

- 1 Ensure that the joint faces of the thermostat assembly and the outlet are clean.
- 2 Fit a new 'O' ring to the thermostat assembly and put the thermostat assembly in position on the cylinder head. Fit and tighten the setscrews.
- 3 Connect the top hose and fill the cooling system.

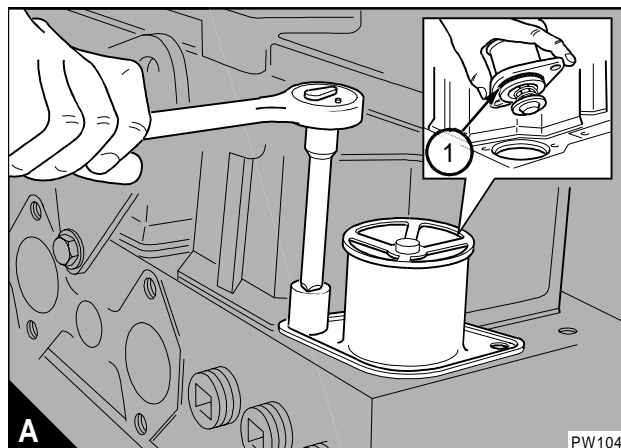

To test

21A-3

- 1 Hang the thermostat in a suitable container filled with water.
- 2 Heat the water gradually. Use a thermometer to check the temperature at which the valve starts to open and at which it is fully open. The correct temperatures are given in data and dimensions.

21A

Coolant pump

To remove and to fit

21A-4

Note: If the water pump becomes unservicable, a new coolant pump must be obtained.

To remove

- 1 Drain the cooling system.
- 2 Remove the drive belt, [see operation 21A-7](#).
- 3 Remove the setscrews from the drive pulley and remove the drive pulley (A).
- 4 Remove the coolant pump fasteners (B1) and remove the coolant pump. Discard the 'O' ring (C2).

Note: The bolt at the 1 o'clock position (B1) passes through the timing case to a nut on the rear of the timing case.

to fit

- 1 Ensure that the joint faces are clean.
- 2 Fit a new 'O' ring (C2) to the coolant pump (C1) and put the coolant pump into position. Fit the nut and bolt (B1) at the 1 o'clock position and tighten finger tight only. Fit the remaining setscrews and tighten finger tight only. Tighten all the fasteners evenly and gradually to 7 Nm (5.5 lbf ft) 0,8 kgf m.
- 3 Fit the drive pulley and tighten the setscrews to 7 Nm (5.5 lbf ft) 0,8 kgf m (A).
- 4 Fit the drive belt, [see operation 21A-7](#).
- 5 Fill the cooling system to the correct level.

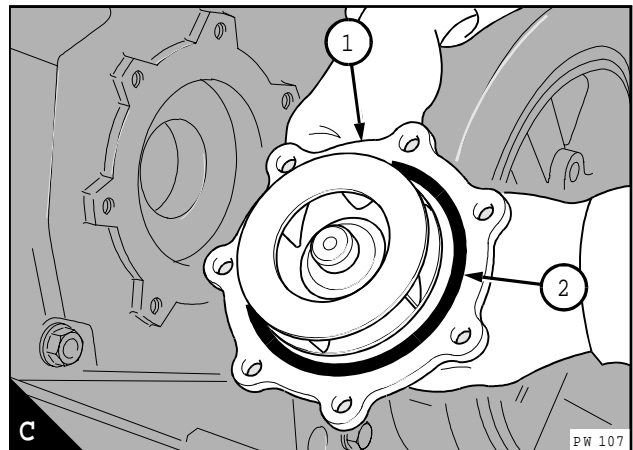
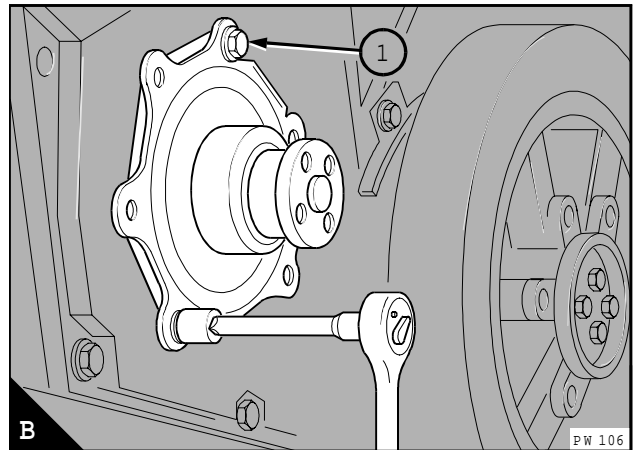
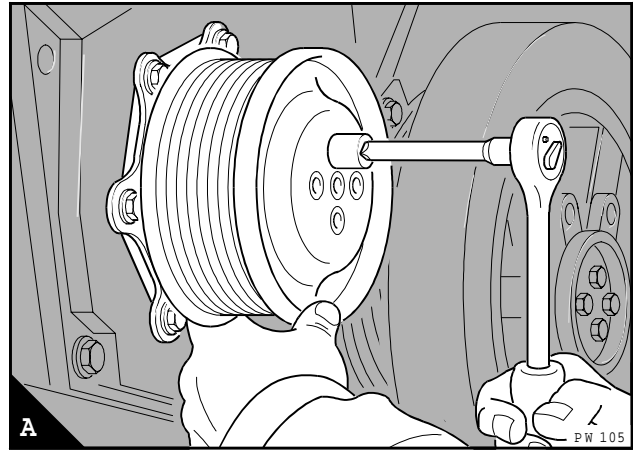

Fan

To remove and to fit 21A-5

To remove

- 1 Remove the fan drive belt, [see operation 21A-7](#).
- 2 Release the setscrews and remove the fan.

To fit

- 1 Clean thoroughly the rear of the fan where it fits onto the fan spacer. Also ensure that all paint is removed from this area. Clean the front face of the fan spacer. Fit the fan and tighten the setscrews.
- 2 Fit the fan drive belt, [see operation 21A-7](#).

Note: There is no need to check the tension of the belt as the tension is set automatically.

Fan drive

To remove and to fit 21A-6

To remove

- 1 Remove the fan, [see operation 21A-7](#).
- 2 Release the setscrews and remove the fan spacer. Remove the drive pulley, if one is fitted, remove the fan pulley.
- 3 Release the setscrews and remove the fan drive.
- 4 Visually inspect the fan drive assembly for damage and wear. If the fan drive is damaged or worn it must be renewed as a unit.

To fit

- 1 Put the fan drive in position, fit and tighten the setscrews to 17 Nm (13 lbf ft) 1,8 kfg m.
- 2 Put the fan pulley, the drive pulley and the fan spacer in position, fit and tighten the setscrews.
- 3 Fit the fan, [see operation 21A-7](#).

21A

Fan drive belt

Note: There is no need to check the tension of the belt as the tension is set automatically.

To remove and to fit

21A-7

To remove

1 Fit a square headed lever (A3) into the 12,7 mm (0.5 in) hole (A2) in the fan tensioner assembly (A1). Operate the lever to release the tension from the belt (A4) and remove the belt. The tensioner will return to its original position by spring pressure. Remove the lever.

To fit

1 With the lever in the fan tensioner, pull the tensioner outwards. Put the fan belt in position around all of the pulleys. Ensure that the tensioner pulley is on the outside of the belt. Allow the tensioner to return and tension the belt. Remove the lever.

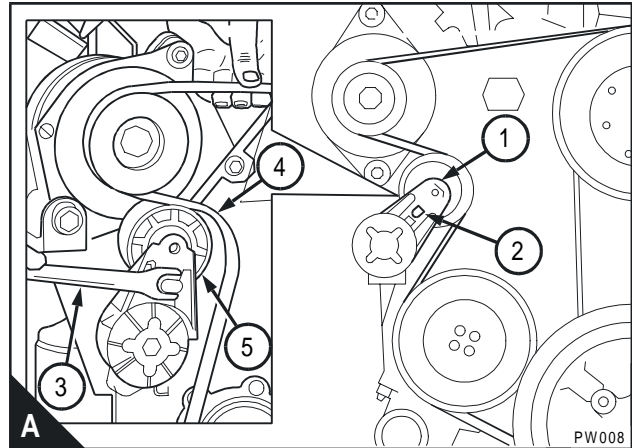

Data and dimensions

Note: This information is given as a guide for personnel engaged on engine overhauls. The dimensions which are shown are those which are mainly used in the factory. The information applies to all engines, unless an engine type code is shown.

coolant pump

type Belt driven, impeller

Coolant filter

type Canister

number 1

Thermostat

Starts to open 82/85 °C (180/185 °F)

Fully open 94 °C (202 °F)

22A

Flywheel and housing

General description

The steel flywheel is fitted with a hardened starter ring.

The flywheel housing is made of cast iron.

Flywheel

Warning! The flywheel weighs 27 kg (59.5 lbs). Use lift equipment or obtain assistance to lift the flywheel.

Caution: When the flywheel is removed or fitted, be careful not to damage the rear oil seal.

To remove and to fit

22A-1

To remove

- 1 Remove two opposite setscrews from the flywheel (A2) and fit temporarily two guide studs (A1) to ensure safety when the flywheel is removed and fitted.
- 2 Remove the remaining setscrews and slide the flywheel out of the flywheel housing (A3).

To fit

- 1 Ensure that the location faces of the crankshaft and the flywheel are clean and free from damage.
- 2 Fit the flywheel over the guide studs (B1) and slide the flywheel into position.
- 3 Fit two opposite setscrews and tighten to finger tight only. Remove the two guide studs.
- 4 Fit the remaining setscrews and tighten all the setscrews to 136 Nm (100 lbf ft) 13,8 kgf m.
- 5 Check the alignment of the flywheel (C1) with a dial test indicator (C2) at a radius of 178 mm (7.0 in). Ensure that the crankshaft is pushed fully toward the front of the engine for each measurement. The maximum tolerance is given in data and dimensions.

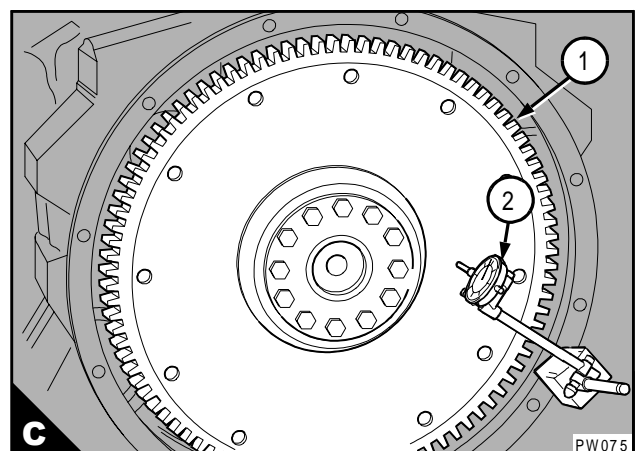
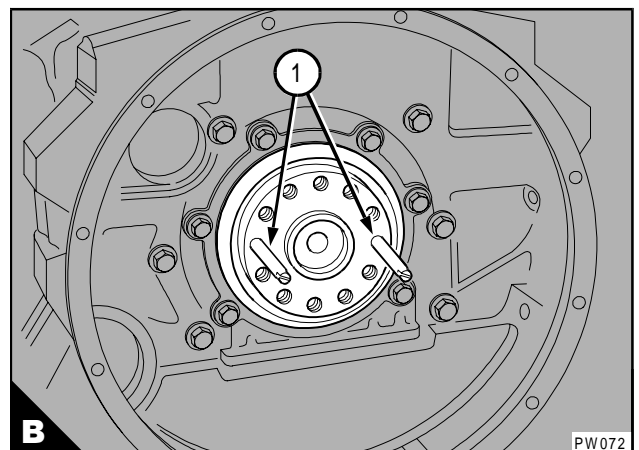
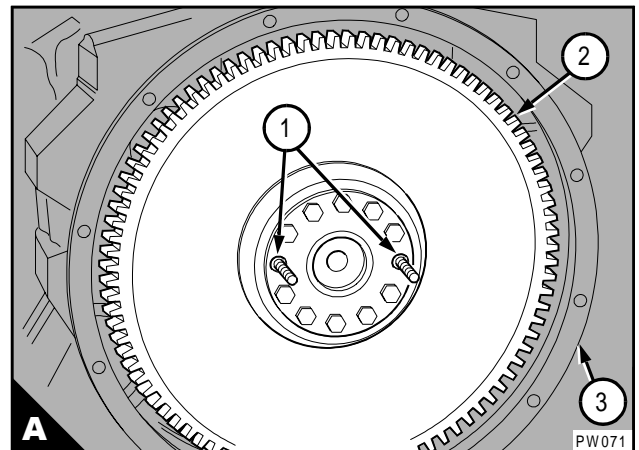

22A

Ring gear

To remove and to fit

22A-2

To remove

Warning! *For this operation eye protection must be used.*

- 1 Before the ring gear is removed, check the position of the chamfer on the teeth.
- 2 To remove the ring gear, use a hammer and a chisel to break the ring. Ensure that the flywheel is not damaged during this operation.

To fit

- 1 The ring gear is heated onto the flywheel. When a new gear is to be fitted, ensure that it is not heated to more than 278 °C (500 °F). Ensure that the ring gear is fully against the shoulder on the flywheel.

Flywheel housing

To remove and to fit

22A-3

Warning! The flywheel housing weighs 33,5 kg (73.87 lbs). Use lift equipment or obtain assistance to lift the flywheel housing.

To remove

- 1 Remove the starter motor, see operation 23A-4.
- 2 Remove the flywheel, see operation 22A-1.
- 3 Release the housing setscrews and remove the housing.
- 4 Remove and discard the camshaft 'O' ring, from the rear face of the crankcase.

To fit

- 1 Ensure that the rear face of the cylinder block and the faces of the housing are clean and free from damage.
- 2 Fit a new camshaft 'O' ring into its recess in the rear face of the crankcase.
- 3 Fit the housing (B2) and tighten lightly the setscrews.
- 4 Check the housing run-out (B) with a dial test indicator (B1) at the 3 o'clock, 6 o'clock, 9 o'clock and 12 o'clock positions. The maximum tolerance is given in data and dimensions. If any adjustment is necessary, it must be made on the housing and the run-out checked again.
- 5 Tighten the setscrews to 108 Nm (80 lbf ft) 11 kgf m.
- 6 Check the housing alignment (A) with a dial test indicator (A1) at the 3 o'clock, 6 o'clock, 9 o'clock and 12 o'clock positions. Ensure that the crankshaft is pushed fully toward the front of the engine for each measurement. The maximum tolerance is given in data and dimensions. Any necessary adjustment must be made on the housing and not on the cylinder block.
- 7 Fit the flywheel, see operation 22A-1.

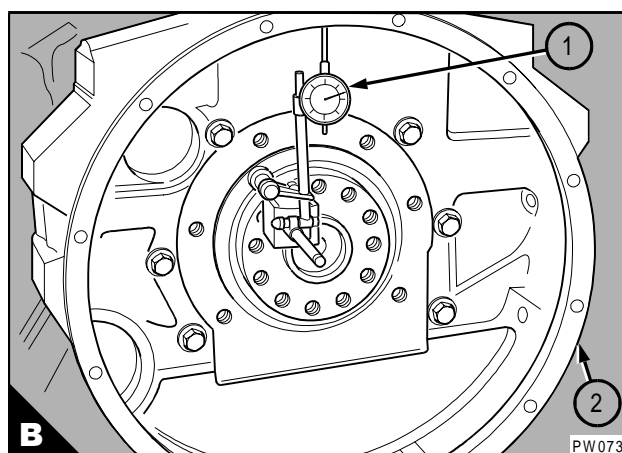
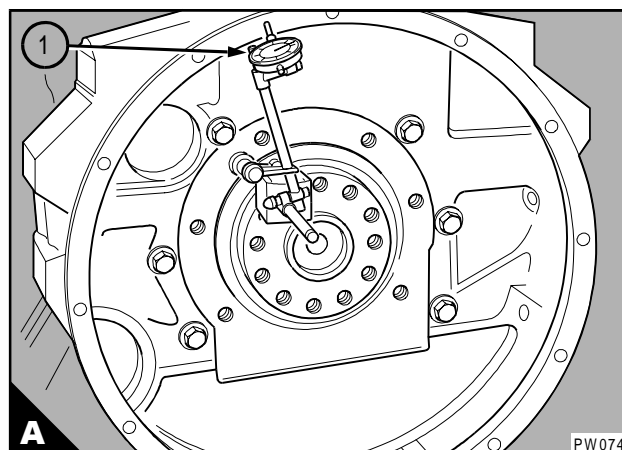

Data and dimensions

Note: This information is given as a guide for personnel engaged on engine overhauls. The dimensions which are shown are those which are mainly used in the factory. The information applies to all engines, unless an engine type code is shown.

Flywheel

Alignment0,013 mm (0.007 in) measured at a radius of 178 mm (7.0 in)
Run-out0,15 mm (0.008 in)
Mounting surface alignment.....0,05 mm (0.002 in)

Flywheel housing

Alignment SAE1 0,030 mm (0.012 in), SAE2 0,028 mm (0.011 in)
Run-out SAE1 0,030 mm (0.012 in), SAE2 0,028 mm (0.011 in)

23A

Electrical equipment

Alternators

General description

The alternator is driven from the crankshaft pulley by a single belt. To remove and to fit the drive belt, [see operation 21A-7](#). There is no need to check the tension of the belt as the tension is set automatically.

The Lucas CAV AC5RS 12 volt and 24 volt alternators have solid state regulators fitted at the rear. The regulators of both alternators are sealed and repair is not possible.

Precautions

To prevent damage to the diodes, the transistors and the resistors, the precautions given below must be followed:

Do not disconnect the battery while the engine is in operation. This will cause a voltage surge in the alternator charge system which will immediately cause damage to the diodes or to the transistors.

Do not disconnect an electrical wire before the engine is stopped and all electrical switches are in the "off" position.

Do not cause a short circuit by the connection of electrical wires to the wrong terminals. The correct electrical wire must be connected to the correct terminal. A short circuit or wrong connection which gives reverse polarity will immediately cause permanent damage to the diodes and to the transistors.

Do not connect a battery into the system until it has been checked for correct polarity and voltage.

Do not check for current flow with a spark contact as damage can be caused to the transistors.

23A

To remove and to fit

23A-1

To remove

- 1 Disconnect the electrical connection.
- 2 Remove the drive belt, [see operation 21A-7](#).
- 3 Loosen the fasteners of the alternator and the fasteners of the alternator bracket. Remove the alternator. Make a note of the position of the washers and distance pieces to ensure that they are fitted correctly.

To fit

- 1 Put the alternator in position and assemble loosely the alternator bracket fasteners. Ensure that the washers and the distance pieces are fitted in their correct positions and that the alternator pulley is aligned to the crankshaft pulley. Tighten the fasteners.
- 2 Fit the drive belt, [see operation 21A-7](#).
- 3 Connect the electrical connection.

To maintain

23A-2

- 1 Ensure that the drive belt is not worn.
- 2 Keep the alternator clean. To clean the alternator, use a material which is damp with kerosene or a special fluid used for this purpose. Ensure that the fluid does not enter the cover of the alternator.
- 3 Ensure that air can pass easily over the casing to keep it cool.

Fault diagnosis

23A-3

If the warning light is not lit or there is a reading on the ammeter, the operation of the alternator is correct. If the system is in correct operation, no open circuit, voltage or current output checks need to be done on the installation unless:

- The warning light does not show when the alternator is stationary and the switch is in the "on" position or it shows a light when the alternator is in operation.
- No charge current is shown on the ammeter.
- The battery is discharged.
- The battery is hotter than normal which is an indication of loss of voltage control.

If one or more of the above symptoms occur, the procedure indicated below should be applied.

- 1 Ensure that the battery is fully charged.
- 2 Connect a moving-coil voltmeter of good quality, with a range of 0-50 volts, across the positive and negative terminals of the alternator. If an ammeter is not fitted in the electrical circuit, fit a moving-coil ammeter of good quality, with a range of 0-100 ampere, in the wire between the alternator and the positive terminal of the battery.
- 3 Turn the warning light switch to the "on" position (main switch on instrument panel); the warning light should be illuminated.
- 4 Switch on a 10-15 ampere load, for example, lights, fans, etc.
- 5 Start the engine and operate it at a fast idle speed; either the warning light should be extinguished or the ammeter indicates a small change in the current in relationship to the engine speed.
- 6 Increase the engine speed for a moment to near maximum speed, when the charge current should be approximately equal to the rating for the alternator.
- 7 Operate the alternator at approximately half speed (engine speed approximately 1500 rev/min) and remove the electrical load. The voltage should go up to 14 volts for a 12 volt system or 28 volts for a 24 volt system and then remain constant. At the same time the current reading should show a reduction.

Any change in the above data can indicate a fault and the procedure that follows should be used before any components are disconnected.

Note: The regulator is a sealed unit and a repair is not possible. If there is a regulator fault, the regulator must be renewed.

If the warning light is not illuminated when the switch is in the "on" position:

- 1 Check the bulb.
- 2 If no fault: Check all the connections at the regulator, at the alternator and at the battery.

3 If no fault: Turn the switch to the "off" position. Disconnect the wire from the "F" terminal on the alternator and connect a wire between the "F" terminal and the negative terminal on the alternator. Turn the switch to the "on" position.

If the warning light shows, the fault is in the regulator.

If the warning light does not show, the fault is in the alternator.

If the warning light continues to show and the ammeter shows no output when the alternator is in operation:

4 Check all the connections at the regulator, alternator and battery.

5 If no fault: Turn the switch to the "off" position. Disconnect the wire from the "F" terminal on the alternator and connect a wire between the "F" terminal and the negative terminal on the alternator. Turn the switch to the "on" position and operate the engine at fast idle. If there is no output, there is a fault in the alternator.

If there is an output, there is a fault in the regulator.

If the warning light continues to show when the alternator is in operation and the ammeter shows a reduced output with maximum output only at maximum engine speed, there is a fault in the alternator.

If the warning light does not show, but there is a reduced output from the alternator with maximum output only at maximum engine speed, there is a fault in the alternator.

If there is an intermittent light from the warning light and the ammeter needle is not stationary when the battery is charged fully and no load is applied.

6 Check for a higher than normal resistance in the negative control wire of the regulator.

If the resistance is normal, there is a fault in the regulator.

If the battery charge is too high and the ammeter indicates high or maximum output at all times:

7 Check the positive control wire and its connection at the regulator.

If the wire and its connection are correct, there is a fault in the regulator.

23A

Wiring diagrams

Lucas AC5RS, 55A

- 1 Alternator
- 2 Ammeter (if fitted)
- 3 Ignition switch
- 4 Alternator warning light 24v 24W

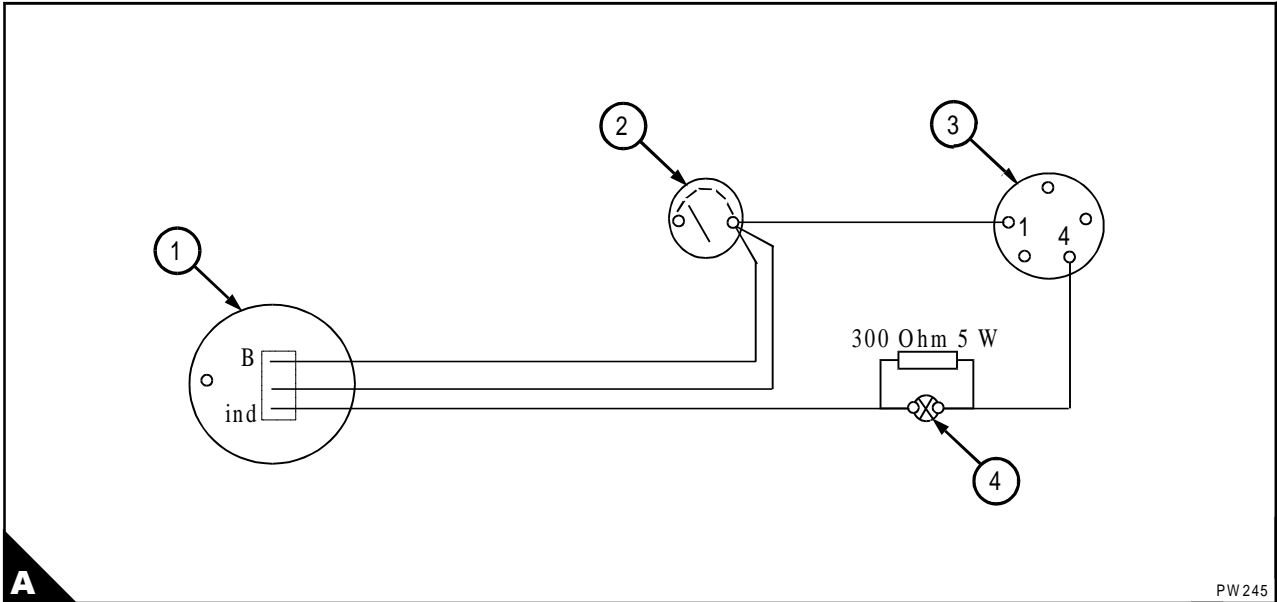

Lucas ACR5RS, 60A

- 1 Alternator
- 2 Ammeter (if fitted)
- 3 Ignition switch
- 4 Alternator warning light 12v 2,2W

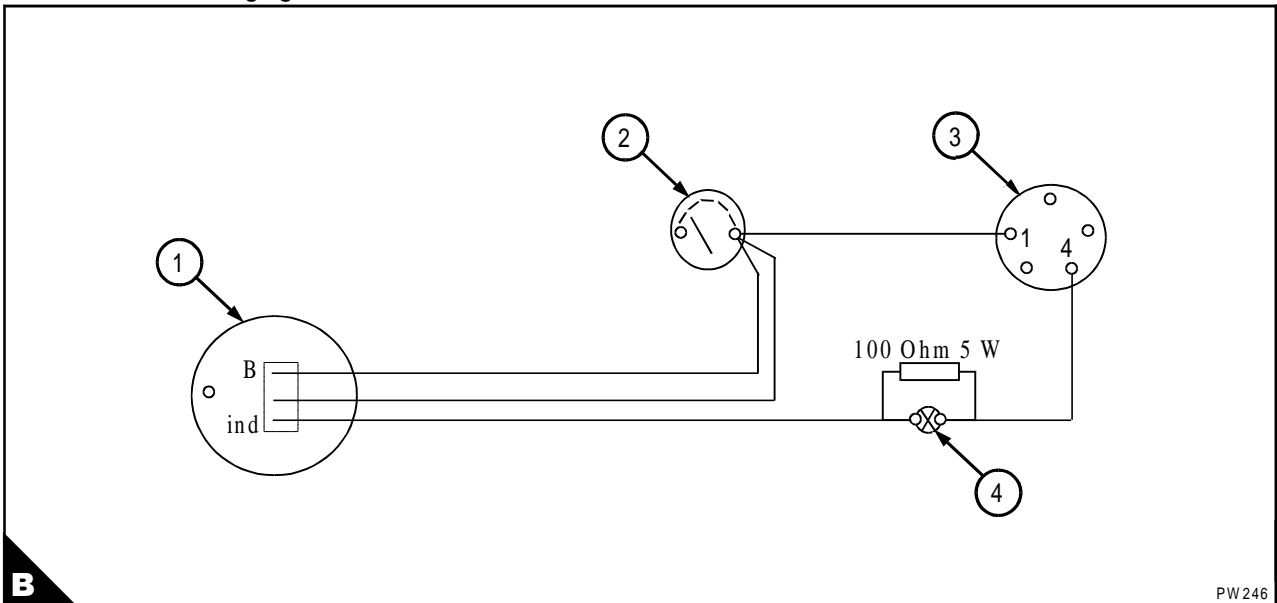

Data and dimensions

Note: This information is given as a guide for personnel engaged on engine overhauls. The dimensions which are shown are those which are mainly used in the factory. The information applies to all engines, unless an engine type code is shown.

The information which follows is general and can change with individual applications.

Alternators

Make and typeLucas AC5RS

Ratings:

- Lucas..... 12V/60A or 24V/55A

Starter motors

General description

The Lucas S115 starter motor has a smooth cylinder surface with no protrusions. This is because the solenoid and the main switch assemblies are inside the drive end cover around (co-axially with) the armature shaft. The main feature of the co-axial starter is that only the pinion assembly moves axially to engage the engine flywheel. There is no axial movement of the whole armature as with the axial type motor. To ensure smooth engagement of the pinion, full load is not applied until the pinion is completely engaged with the flywheel.

The Lucas PE129 is a pre-engaged starter motor and is actuated by a solenoid. The solenoid is fitted to the starter motor outer casing. When the starter button or key is operated, the solenoid pulls a lever to engage the pinion in the starter ring, against spring pressure. As soon as the pinion is fully in mesh with the starter ring, the starter relay electrically connects the starter motor directly to the batteries. When the engine runs, the starter button or key is released, current to the solenoid is stopped and the solenoid is de-energised. Current to the starter motor from the batteries is stopped. Spring pressure on the lever disengages the pinion from the starter ring.

To remove and to fit

23A-4

To remove

- 1 Disconnect the battery.
- 2 Disconnect the starter motor cables.
- 3 Release the fasteners and remove the starter motor and, if necessary, the distance piece.

To fit

- 1 If necessary, put the distance piece in position with its location lip to the flywheel housing. Fit the starter motor and tighten the fasteners.
- 2 Connect the starter motor cables.
- 3 Connect the battery.

To maintain

23A-5

1 Inspect the brushes at intervals to ensure that they are free in their guides and that the wire connections are free to move. To check this, lift the spring from the brush and pull carefully on the flexible connections. If the brush does not move freely, remove it from its holder and clean the sides with a material which is damp with gasolene.

2 Ensure that the brushes are fitted in their original positions to keep the original wear seat. The brushes must have good seats which conform to the shape of the commutator. If the brush seat is not correct, put a piece of very fine carborundum paper or similar material tight around the commutator with the rough face to the outside.

3 With the brush in position, turn the armature by hand, in the normal direction of rotation, until the brush has the correct shape. If the brushes are so worn that the springs do not give enough pressure, they must be renewed.

4 Check the spring pressure with the hook of a spring balance under the spring lip. The correct tension is 8,34/11,00 N (30/40 ozf) 0,85/1,13 kgf.

5 The new brushes must be the same grade as the original brushes. To ensure that correct brushes are fitted, use only parts from the approved manufacturer.

6 To remove the brushes, remove the four setscrews that hold the brushes, one for each brush.

7 When the new brushes are assembled, connect carefully the field coil and connector wires, held by two of the setscrews. Before the brushes are inserted in their holders, it is advised that the holders are cleaned with compressed air or with a material which is damp with gasolene.

8 The commutator must be completely clean; dirt or oil must be removed by a piece of clean dry material (with no loose fibres) pressed against it, while the armature is turned by hand.

9 If the commutator is dirty and has a colour other than its natural colour, lift the brushes and put a strip of fine carborundum paper or similar material around the commutator, with the rough surface to the inside. Turn the armature by hand until the surface has returned to its natural colour. Clean the commutator with a material which is damp with gasolene.

10 If a repair is necessary to the commutator or switch gear, etc. the starter must be removed for specialist repair.

To test on the engine

23A-6

- 1** Ensure that the battery is fully charged.
- 2** Turn on the lights and operate the starter switch. If no lights are fitted to the machine, connect a voltmeter across the battery terminals and operate the starter switch.
- 3** If the starter does not operate, but the lights keep their power or there is no voltage drop across the battery, check the switch, all the connections and the wires.
- 4** Slow action of the starter can be caused by faulty connections.
- 5** Difficulty to engage smoothly between the starter and the flywheel can be caused, on some types of starter motor, by dirt on the helical grooves of the starter motor drive, which can prevent free movement of the pinion.
- 6** Clean the shaft thoroughly with gasolene, or a fluid made specially for the purpose, and apply a small quantity of Aero Shell 6B or its equal.

Wiring diagrams

PE129 (A)

- 1 2 x 12v batteries in parallel
- 2 Fuse F12, 30 Amps
- 3 Ammeter, if fitted
- 4 Ignition switch
- 5 Pin 46 on the engine control module
- 6 33 RA relay
- 7 Start inhibit relay, 60 Amps
- 8 Starter motor

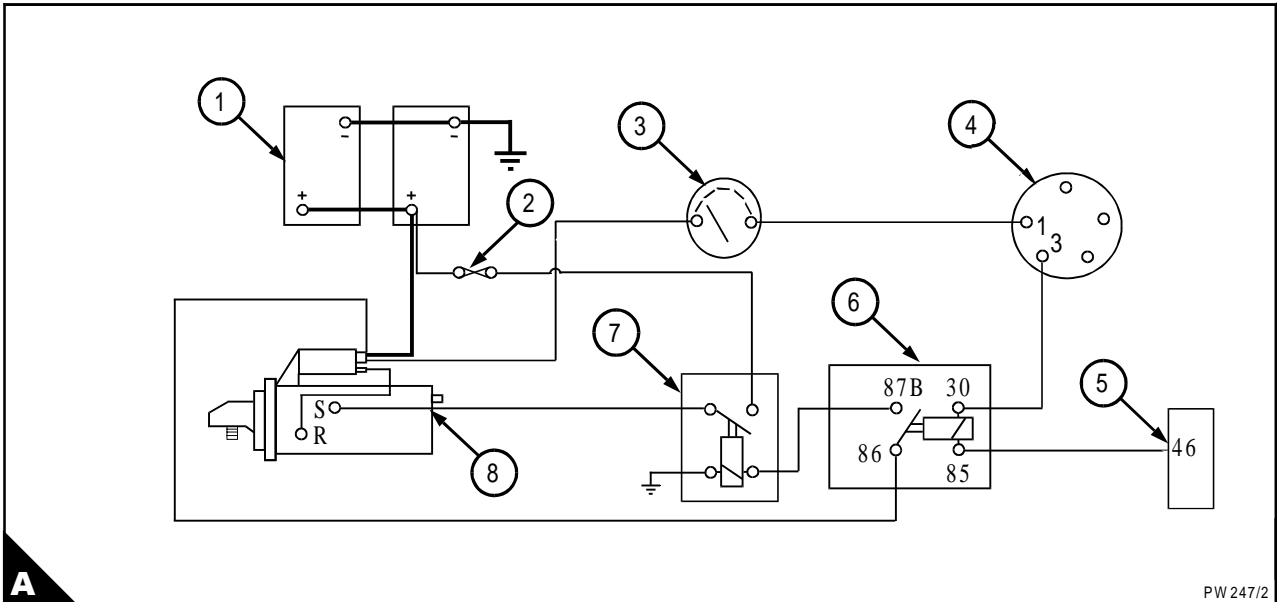

S115 (B)

- 1 2 x 12v batteries in series
- 2 Fuse F12, 30 Amps
- 3 Ammeter, if fitted
- 4 Ignition switch
- 5 Pin 46 on the engine control module
- 6 33 RA relay
- 7 Start inhibit relay, 60 Amps
- 8 Starter motor

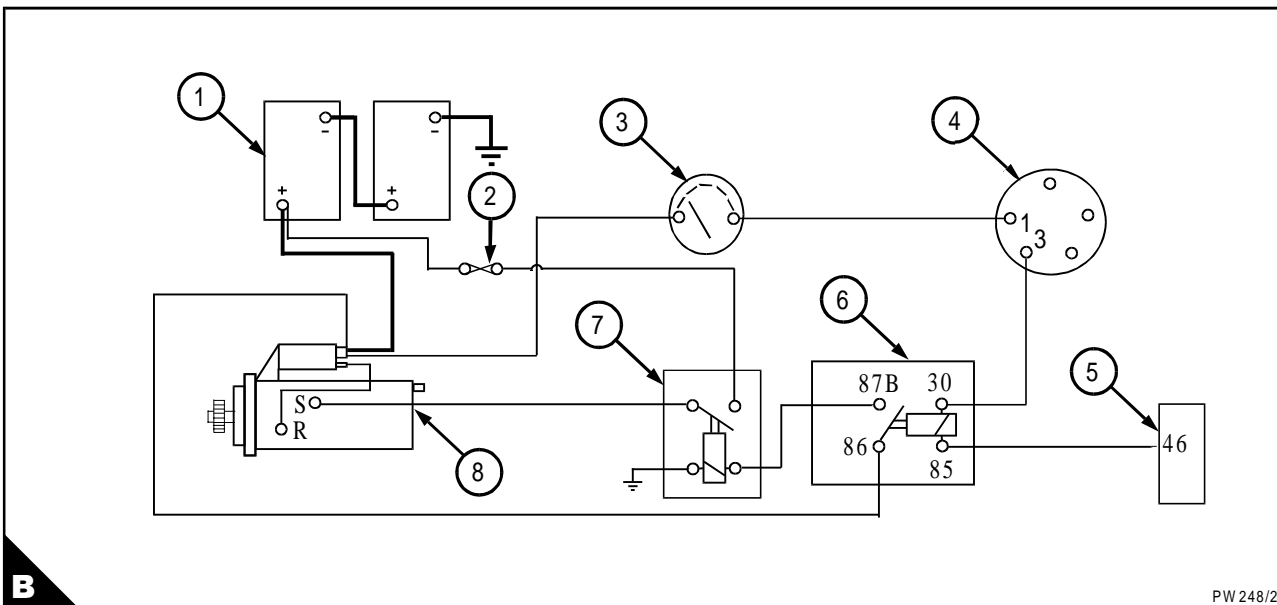

Data and dimensions

Note: This information is given as a guide for personnel engaged on engine overhauls. The dimensions which are shown are those which are mainly used in the factory. The information applies to all engines, unless an engine type code is shown.

The information which follows is general and can change with individual applications.

Starter motors

Make and type Lucas S115, Lucas PE129

Ratings:

- Lucas 12V/4.25kW or 24V/6kW

Starting aid

General description

An ether start system is used to start the engine at temperatures below -20 °C (-4 °F).

At temperatures below -20 °C (-4 °F) the system thermostat contacts are closed. When the starter motor solenoid is energised, the ether start solenoid is also energised. The ether start solenoid will remain energised during engine start and while the alternator is charging.

Note: See section 3 of the User's Handbook for, "How to start an engine with an ether start system".

Engine management system

General description

The engines have an electronic management system. The engine control module (A1) is the main component of the system.

The engine control module sends a reference voltage of 5 volts to several sensors (A2 to A10), and the sensors send return voltages to the module. The sensors send an analogue signal. An analogue signal is one which can show any value between two different values.

The module uses the value of the return voltages to calculate pressures, temperatures, position of the camshaft and engine speed. The module then:

- sends a pulse of 110 volts to the solenoid of each fuel injector unit (A12) in sequence, to control the start of injection, and the end of injection.
- modulates the voltage to the solenoid of the regulator valve (A11), to change the injection control pressure, see , see 'Regulator valve" on page 138.

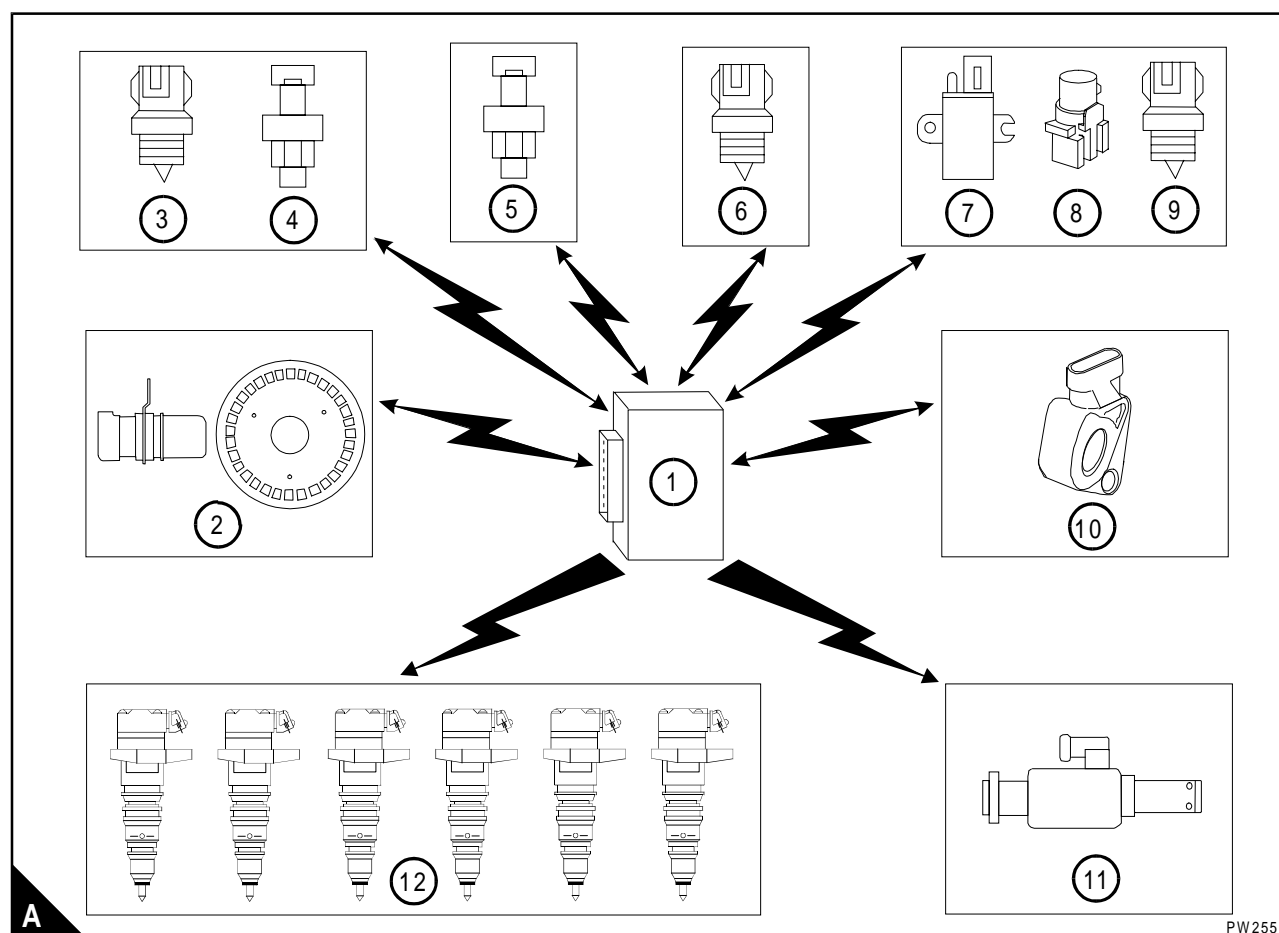

Sensors

Note: See opposite page for illustrations.

There are four types of sensor in this system:

- Variable capacitance
- Thermistor
- Potentiometer
- Hall-effect

Variable capacitance sensors

Variable capacitance sensors are used to measure pressure. Changes in pressure will cause changes to the signal from the sensor.

In the case of the sensors for:

- engine oil pressure (23D.2/A4)
- injection control pressure (23D.2/A5)
- atmospheric pressure (23D.2/A8)

If the pressure decreases, the *value* of the return voltage will decrease.

If the pressure increases, the *value* of the return voltage will increase.

In the case of the sensor for:

- inlet manifold pressure (23D.2/A7).

If the pressure decreases, the *frequency* of the return voltage will decrease.

If the pressure increases, the *frequency* of the return voltage will increase.

Thermistors

Thermistors are used to measure temperature.

They are the sensors for:

- Engine oil temperature (23D.2/A3)
- Coolant temperature (23D.2/A6)
- Ambient temperature (23D.2/A9).

Changes in temperature will cause a change in the resistance of the sensor.

- If the temperature decreases, the resistance increases and the return voltage will increase.
- If the temperature increases, the resistance decreases and the return voltage will decrease.

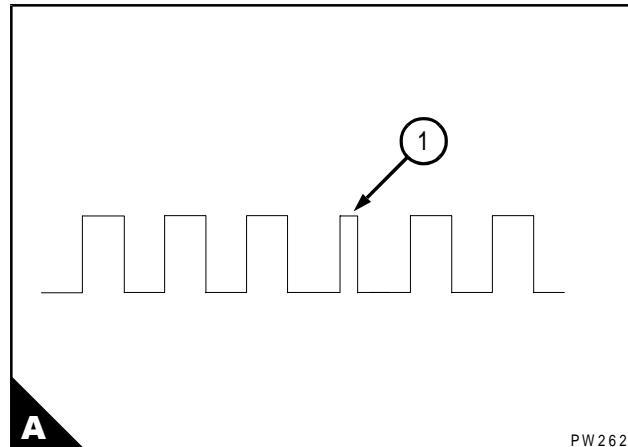

Potentiometers

Potentiometers are used to measure the position of a mechanical device.

The speed control (23D.2/A10) is connected to a potentiometer, changes in its position will cause a change in the return voltage of the potentiometer.

- If the return voltage increases, the engine speed will increase.
- If the return voltage decreases, the engine speed will decrease.

The signal from the speed control sensor does not assist with calculating engine speed, it only shows the position of the speed control.

Hall-effect sensors

Hall-effect sensors are used to measure the speed and position of a rotating mechanical device. The camshaft position sensor (23D.2/A2) is a Hall-effect sensor.

The sensor contains a magnet, when its magnetic field is cut a digital voltage is generated by the sensor in the form of a pulse.

The timing disc, fitted to the camshaft, has many vanes which cut through the magnetic field of the sensor. The vanes are of equal width, except one which is thinner. When the thin vane cuts through the magnetic field, it produces a pulse which is shorter (A1) in duration than those of the other vanes.

The engine control module uses the short pulse to calculate the position of the camshaft, and uses all of the pulses to calculate and control engine speed.

Wiring diagram

Components - numbers shown in triangles

- 1 Main power relay for the engine control module (ECM)
- 2 Drive condition switch. a = enable, b = disable
- 3 Start inhibit relay
- 4 To starter motor relay
- 5 Diagnostic connector
- 6 Diagnostic switch
- 7 Exhaust brake enable switch. a = off, b = on
- 8 Air-valve solenoid for the exhaust brake
- 9 Transmission kick-down relay
- 10 To the transmission controls
- 11 Two-speed axle switch. a = low, b = high
- 12 Demand switch to increase power from the air conditioning compressor
- 13 Air-valve solenoid for the radiator fan
- 14 Air-valve solenoid for the radiator-shutter

ECM pin-outs

- 1 Negative (-) for the DC/DC converter
- 2 Negative (-) for the DC/DC converter
- 16 Positive (+) for the ATA data link
- 17 Negative(-) for the ATA SAE J1708
- 21 Positive (+) for the DC/DC converter
- 22 Negative (-) from the battery
- 24 Positive (+) from the ignition switch, when "ON"
- 25 Control output for the power relay
- 26 Input from the drive switch, 12 v when the drive is dis-engaged
- 28 Input from two-speed axle switch
- 33 Input from the demand switch to increase power from the air conditioning compressor
- 34 Input from the self-test switch
- 41 Positive (+) from the battery
- 42 Negative(-) for outputs
- 46 Output to the start inhibit relay
- 47 Output to the electric fan
- 51 Output to the radiator-shutter
- 56 Output to the kick-down relay

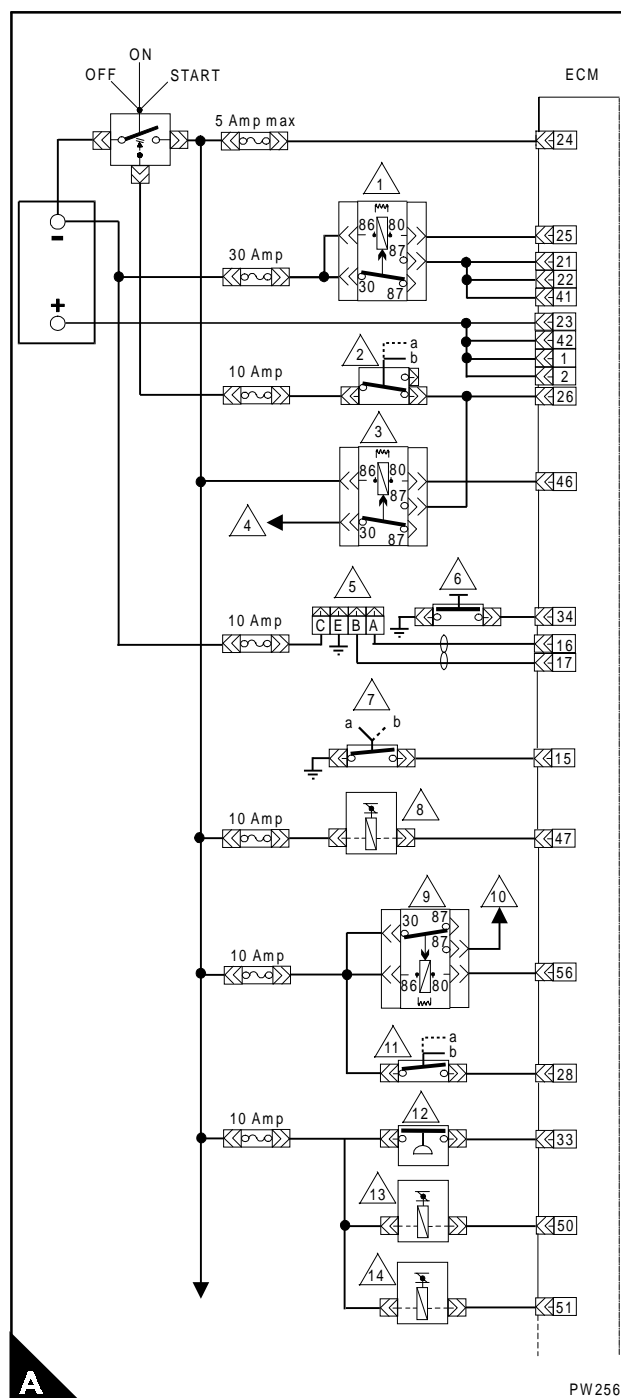

Continued

Wiring diagram *continued*

Components - numbers shown in triangles

- 1 Brake switch number 1. a = off, b = on
- 2 Brake switch number 2. a = off, b = on
- 3 Cruise-control. a = off, b = on
- 4 Remote PTO switch. a = on, b = off
- 5 Speed switch
a = reset accelerator, b = set coast
- 6 Speed switch, remote
a = reset accelerator. b = set coast
- 7 Pre-set speed switch. a = off, b = on
- 8 Variable speed switch. a = off, b = on
- 9 Hydraulic pressure governor switch.
a = off, b = on
- 10 Hydraulic pressure governor control relay
- 11 Warning light to show that the speed control mode is active
- 12 Warning light to show that the pressure control mode is active
- 13 Remote speed control sensor
- 14 Hydraulic pressure switch
- 15 Accelerator pedal position sensor
- 16 Barometric air pressure sensor
- 17 Ambient air temperature sensor
- 18 Vehicle speed sensor
- 19 Instrumentation
- 20 Coolant level switch
- 21 Computer data link connector

ECM pin-outs

- 3 Reference voltage (+5v) for the speed control sensor
- 4 Hydraulic pressure governor enable input
- 5 Reference voltage (+5v) for the remote speed control sensor
- 6 (0v) for the remote speed control sensor
- 7 Reference voltage (+5v) for the hydraulic pressure sensor
- 8 Input from the speed control sensor
- 9 Not used
- 10 Input from the coolant level switch
- 11 (0v) for the speed control sensor
- 12 Input from the ambient air temperature sensor
- 13 Input from the hydraulic pressure sensor
- 14 Not used

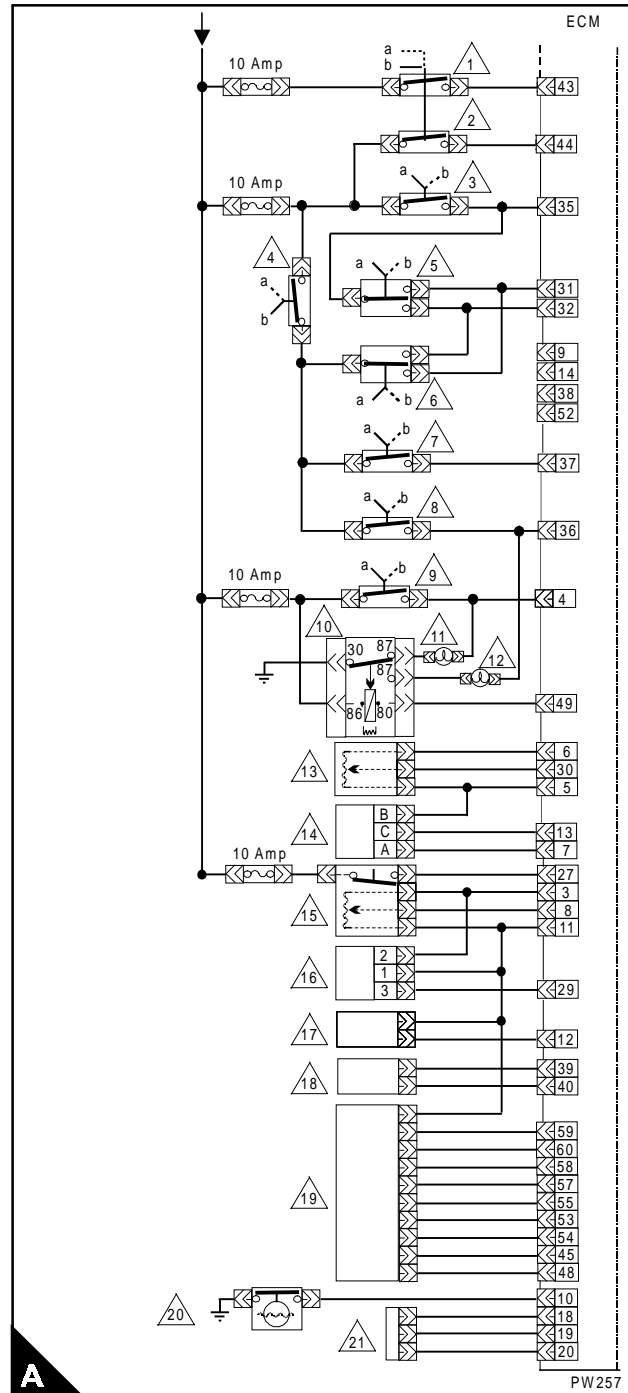

Continued

Wiring diagram *continued*

ECM pin-outs

- 18 Interference screen for the computer data link connector
- 19 Computer access positive (+)
- 20 Computer access negative (-)
- 27 Input from the speed control sensor, to confirm that the speed control is in the idle position
- 29 Input from the atmospheric air pressure sensor
- 30 Input from the remote speed control sensor
- 31 Input from the resume / accelerate switch
- 32 Input from the cruise-control (set/coast)
- 35 Input from the cruise-control (on/off)
- 36 Input from the variable speed switch, for the remote speed control
- 37 Input from the pre-set speed switch, for the remote speed control
- 38 Not used
- 39 Positive (+) input from the variable speed switch
- 40 Negative (-) input from the vehicle speed sensor
- 43 Input from the number 1 brake switch (on/off)
- 44 Input from the number 2 brake switch (on/off)
- 45 Service interval warning light
- 48 Output to the shift-up warning light
- 49 Output to the control relay for the hyd pressure governor
- 52 Not used
- 53 Output to the glow plug warning light
- 54 Output to the oil/water warning light (pressure/temperature)
- 55 Output to the engine warning light
- 57 Output to the vehicle speed sensor, calibration B
- 58 Output to the vehicle speed sensor, calibration A
- 59 Output to the tachometer, A
- 60 Output to the tachometer, B

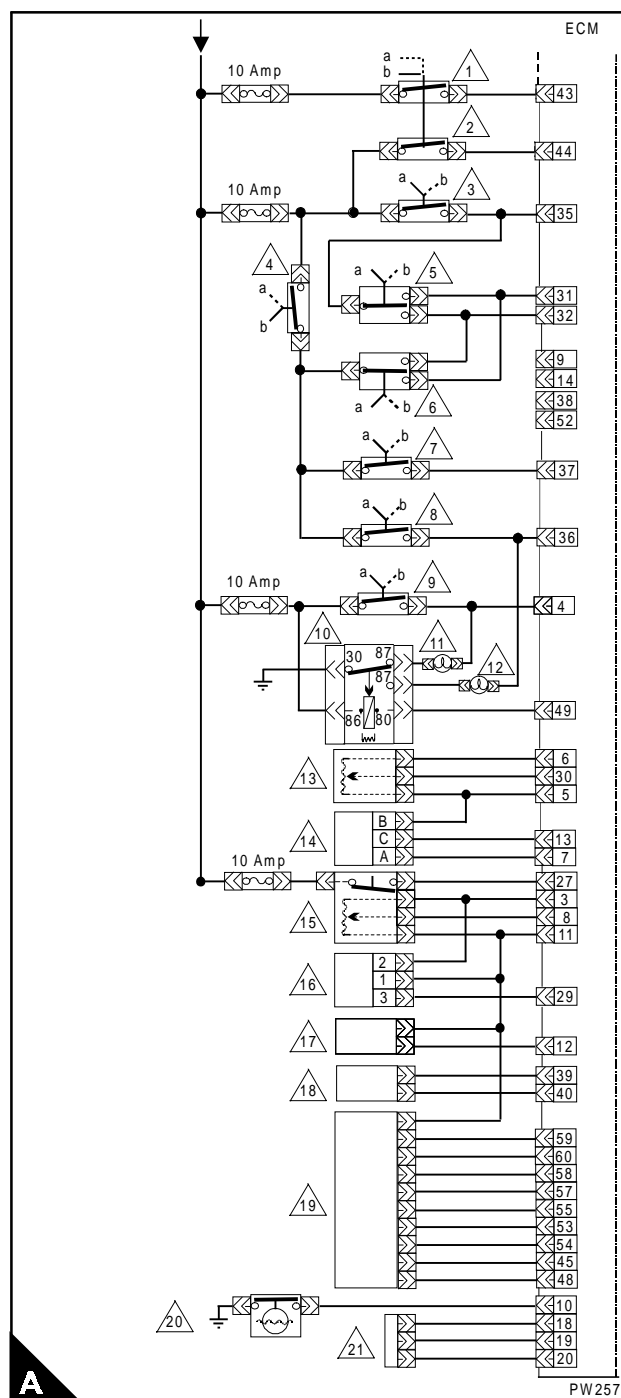

24A

Auxiliary equipment

Compressors

General description

The Bendix 2150, Bendix 550 and Bendix 750 direct drive compressors are fitted to the rear face of the timing case on the left side of the engine. The drive gear for the compressor is engaged with the lower idler gear in the timing case.

The cylinder head of the single cylinder compressor is cooled by coolant from the engine. The compressor is lubricated from the lubrication system of the engine. Oil passes through an external pipe from the engine pressure rail to the compressor crankcase. The oil passes to the main bearings and the big end bearings of the compressor and also to the rear bush for the drive shaft. Oil which drains from the compressor crankcase into the drive housing lubricates the drive gears and the bearing. The oil returns to the engine sump through the timing case.

Operation

As the piston moves down the cylinder, air pressure above the piston is reduced. The reduction in air pressure opens the inlet valve and allows air to enter the cylinder above the piston. As the piston moves up the cylinder, air pressure under the valve and the action of the valve spring closes the valve. The increase in air pressure under the delivery valve, opens the valve and air is discharged to the reservoir. Air pressure in the reservoir is controlled by an unloader valve which, at a certain pressure, holds the inlet valve of the compressor open until air pressure in the reservoir is reduced.

To remove

- 1 Drain the engine cooling system.
- 2 Release the air pressure in the air system.
- 3 Disconnect the air pipes from the compressor.

Caution: *The top coolant hose is permanently fitted to the compressor, it must be disconnected at the cylinder block end and removed from the engine as a part of the compressor.*

- 4 Disconnect the coolant pipes between the compressor and the cylinder block of the engine.
- 5 Remove the lubricating oil pipe from the compressor.
- 6 If necessary, remove the power steering pump from the rear of the compressor, [see operation 24A-2](#).
- 7 Support the compressor. Loosen the two nuts and bolts which fasten the compressor to its support bracket. Loosen the two setscrews which fasten the support bracket to the cylinder block.
- 8 Remove the two setscrews which hold the compressor to the timing case.
- 9 Remove the support bracket and its fasteners.

Note: Spacers are used between the compressor bracket and the compressor body.

- 10 Remove the compressor from the engine.

To fit

- 1 Fit the compressor to the timing case, ensure that the drive gear is in mesh with the lower idler gear. Tighten the setscrews to 62 Nm (46 lbf ft) 6,4 kgf m.
- 2 Fit the setscrews for the compressor bracket to the engine and tighten to 115 Nm (85 lbf ft) 11,7 kgf m.
- 3 Fit the setscrews for the compressor bracket to the compressor and tighten to 66 Nm (49 lbf ft) 6,7 kgf m.
- 4 Ensure that there is no restriction in the oil pipe between the engine and the compressor. Before the oil pipe is connected to the compressor, ensure that the engine stop solenoid is disconnected or that the engine stop control is in the 'stop' position. Operate the starter motor until a free flow of oil comes from the oil pipe. Connect the engine stop solenoid.
- 5 Connect the oil pipe, the compressor coolant pipes and the air pipes to the compressor.
- 6 Fill the engine cooling system.
- 7 Start the engine and check for leakage of oil, coolant or air from the compressor.

Power steering pump

To remove and to fit

24A-2

To remove

- 1 Disconnect the connections at the power steering pump and fit covers to the openings.
- 2 Release the setscrews and remove the pump.
Discard the 'O' ring.

To fit

- 1 Fit a new 'O' ring and lubricate it with clean engine lubricating oil.
- 2 Fit the drive shaft into the end of the compressor output flange and push the pump fully into position.
- 3 Fit and tighten the setscrews.
- 4 Remove the covers from the openings and connect the connections.

24A

Power take-off adaptor

To remove and to fit

24A-3

To remove

- 1 Remove the power steering pump, see operation 24A-2.
- 2 Release the setscrews and remove the PTO adaptor. Discard the joint.

To fit

- 1 Fit a new joint to the adaptor and lubricate the joint with clean engine lubricating oil.
- 2 Fit the drive gear into the end of the compressor output flange, or into the timing case if a compressor is not fitted. Push the pump fully into position.
- 3 Fit and tighten the setscrews.
- 4 Fit the power steering pump, see operation 24A-2.

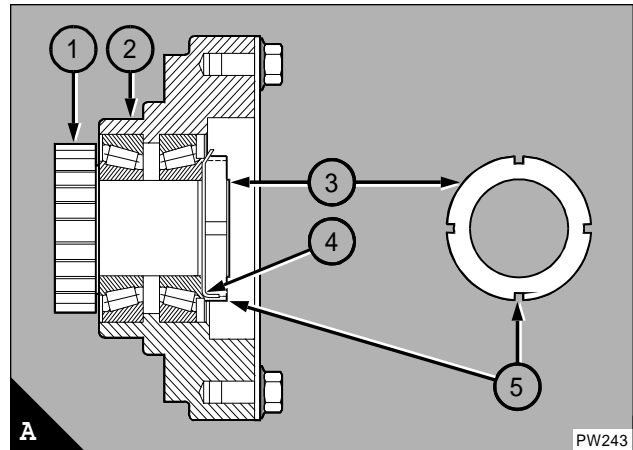

To tighten the drive gear nut



24A-4

- 1 Press the drive gear (A1) of the PTO adaptor into the bearings in the housing (A2) of the PTO adaptor.
- 2 Fit the lock plate (A4) to the shaft of the drive gear.
- 3 Fit and tighten the nut (A3) until the end-float of the drive gear is eliminated.
- 4 Release the nut 1/24 of a turn (15° to 20°) to give an end-float of 0,025/0,076 mm (0.001/0.003 in). Rotate the nut until the nearest tag on the lock plate aligns with a slot (A5) in the nut.
- 5 Bend the tag until it fits into the slot to lock the nut in position.

25A

Special tools

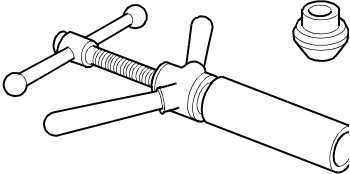
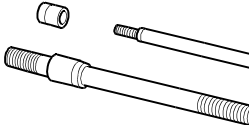
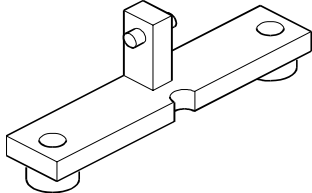
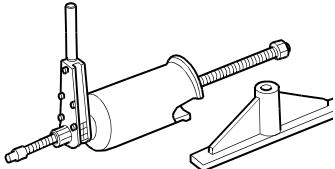
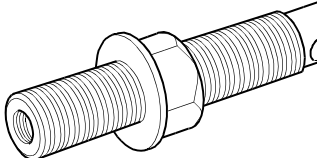
List of special tools

Part number	Description	Illustration
21825478	Remover/ replacer for valves guides (main tool) Tool number PD.1D	
21825479	Adaptor for remover/ replacer for valve guide Tool number PD.1D-1A	
21825496	Gauge for valve height, for use with PD.208. Tool number PD.41D	
21825543	Remover for cylinder liner (main tool) Tool number PD.150-B	
21825577	Replacer for crankshaft front oil seal Tool number PD.170	
21825617	Dial gauge for use with PD.41D. Tool number PD.208	

25A

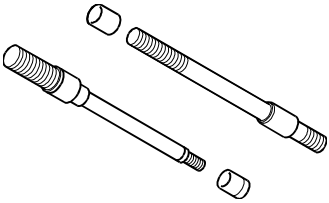
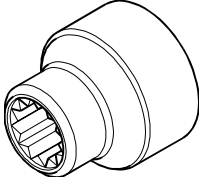
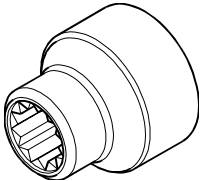
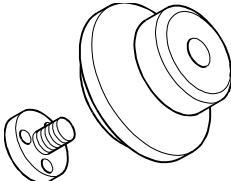
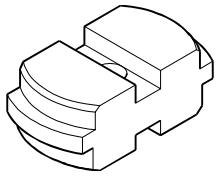
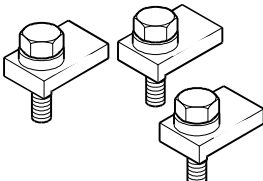
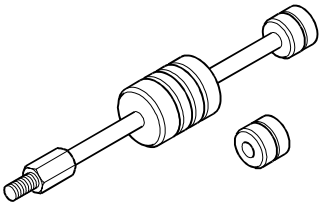
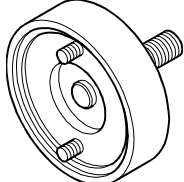
Part number	Description	Illustration
21825935	Adaptor for replacer/ remover for valve guide Tool number PD.1D-11	
21825950	Socket for upper idler gear Tool number PD.224	
21825951	Socket for lower idler gear Tool number 1PD.225	
21825953	Adaptor for installer for front oil seal Tool number PD.227	
21825956	Adaptor for liner remover Tool number PD.231	
21825959	Holding kit for cylinder liner Tool number PD.234	
21825960	Remover for the Injector unit sleeve Tool number PD.235	
21825963	Installer for rear oil seal Tool number PD.237	

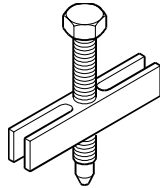
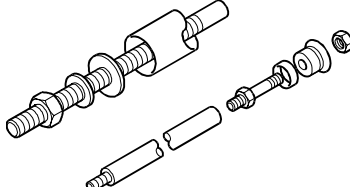
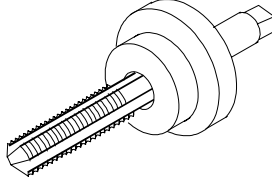
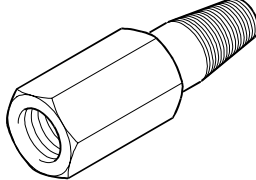
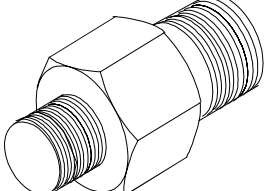
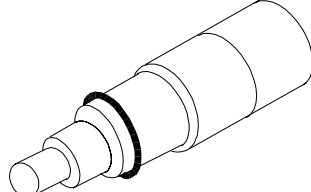
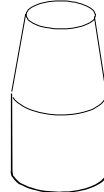
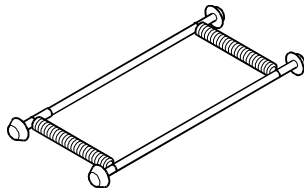
Part number	Description	Illustration
21825965	Puller for crankshaft pulley/ damper assembly Tool number PD.240	
21825995	Remover / replacer camshaft bush Tool number ZTSE 2893A	
27610091	Special tap Tool number PD.250	
27610092	Adaptor for injector unit sleeve remover Tool number PD.251	
27610093	Adaptor for use with 21825960 and 27610092 Tool number PD.252	
27610094	Installer for injector unit sleeve Tool number PD.253	
27610095	Installer for injector unit seals Tool number ZTSE 4299	
21825954 21825955	0.090 inch gauge for piston ring groove Tool number PD.229 0.115 inch gauge for piston ring groove Tool number PD.230	

26A

Fault diagnosis

General description

This section has information that will assist with the diagnosis of mechanical faults and electronic faults on the engine, and its management system.

Two types of faults are found by the engine control module (ECM) and retained in its memory, they are active faults and inactive faults. Active faults and inactive faults are shown on the diagnostic tool as "ACTIVE CODES " and "INACTIVE CODES".

- *An active fault is one which was found by the engine control module and has not been repaired. When an active fault has been repaired, it becomes an inactive fault after 15 seconds.*
- *An inactive fault is one which was an active fault at some time but is not present now. This could be because it was repaired, or it is an intermittent fault.*

Some applications are fitted with a self-test system which can be used to check for active fault and inactive fault . It will also check all outputs for open circuit.

A special diagnostic tool, the Pro-link 9000, is necessary to operate the full range of diagnostic tests on the engine management system.

Basic diagnostics

Special tools:

Multimeter

Clear container of approximately 1 litre (1.76 pints) capacity.

1 Try to start the engine and check if the crankshaft rotates.

If it does, [go to paragraph 3](#).

If it does not, [go to paragraph 2](#).

2 Attempt to rotate the engine crankshaft by hand.

If it does, test the engine starter circuit, see section 23.

If it does not, inspect the engine for a mechanical obstruction or failure, e.g. a seized engine.

3 Check the fuel system:

Check that there is sufficient fuel in the tank.

If an in-line fuel tap is fitted, switch it to the "ON" position.

Check that there is fuel available at the fuel filter.

Eliminate air from the fuel system, [see operation 20A-7](#).

Check that there is not a leakage of fuel.

Check that the fuel strainer and the filter are clean and serviceable. To renew the strainer and filter, [see operation 20A-4](#).

Check that the fuel is clean and to the correct specification. Drain some fuel into a clear container and inspect it for wax or contamination e.g. water, coolant, debris or lubricating oil. Wax can occur in the fuel in extreme cold conditions. Coolant or lubricating oil in the fuel could be caused by leakage at the seals for the fuel injector unit.

4 Check the air inlet and the exhaust system:

Check that the air filter restriction indicator.

Check that the air filter is clean and serviceable.

Ensure that there is not a blockage in the pipework and that there is no internal or external damage to the pipes or hoses.

5 Check the engine lubricating oil system:

Check that the level of engine lubricating oil in the sump is correct.

Remove the sensor for engine oil temperature from the rear of the timing case. Check the level of engine lubricating oil in the reservoir for the high-pressure pump. If the level is too low, the fuel injector units will not operate.

Check that there is not a leakage of lubricating oil.

Check that the filter for the lubricating oil is clean and serviceable. To renew the canister of the lubricating oil filter, [see operation 19A-1](#).

Check that the lubricating oil is clean and to the correct specification, drain some lubricating oil into a clear container and inspect it for contamination e.g. water, fuel, coolant or debris.

6 Check the cooling system:

Check that there is there sufficient coolant in the system.

Check that the radiator core is free from restriction or debris.

Check that there is not a leakage of coolant.

Check that the coolant is clean and to the correct specification, drain some coolant into a clear container and inspect it for contamination e.g. fuel, debris or lubricating oil.

Ensure that there is not a blockage in the pipework and that there is no internal or external damage to the pipes or hoses.

7 Check the electrical systems:

Check all of the fuses.

Check that the engine wiring looms are in their correct positions, and are they fastened to the engine.

Check that all connectors are fitted correctly and securely.

Check that the cables or components are not damaged.

Inspect the battery cable connections for corrosion. If there is corrosion, clean the terminals and connectors thoroughly.

Note: If the camshaft position sensor or the regulator valve for injection pressure are faulty, the engine will not start.

The self-test system

How to check for faults codes

26A-1

If the self-test system is fitted to the application, it can be used to find faults in the engine management system.

The self-test system usually consists of a button, an orange lamp and a red lamp.

- 1 Set the start switch to the 'ON' position, but do not start the engine.
- 2 Press the self-test button once.

Note:

- If there are no 'ACTIVE CODES' retained in the memory of the ECM, the red lamp will flash once, then the orange lamp will flash three times. For further information on flash codes, [see page 215](#).
 - If there are any 'ACTIVE CODES' retained in the memory of the ECM, the red lamp will flash once. Then the orange lamp will flash a code. If there is more than one code retained, there will be a short delay between codes.
 - When all of the retained 'ACTIVE CODES' have been shown, the red lamp will flash twice. Then, if there are any 'INACTIVE CODES' retained, the orange lamp will flash a code. If there is more than one code retained, there will be a short delay or the red lamp will flash once, between codes.
 - When the test is complete, the red lamp will flash three times.
- 3 Make a note of any codes that are shown.
 - 4 Set the start switch to the 'OFF' position.

How to test for an open circuit

26A-2

This test will check the outputs for open circuit faults.

Note: Before this test is done, check for faults codes first, [see operation 26A-1](#). This will assist with fault diagnosis.

- 1 Set the start switch to the 'OFF' position.
- 2 Press and hold the self-test button. Set the start switch to the 'ON' position, but do not start the engine.
- 3 Release the self-test button.
- 4 Make a note of any codes that are shown.

Note:

- If there are any 'ACTIVE CODES' retained in the memory of the ECM, the red lamp will flash once. Then the orange lamp will flash a code. If there is more than one code retained, there will be a short delay between codes.
 - When all of the retained 'ACTIVE CODES' have been shown, the red lamp will flash twice. Then, if there are any 'INACTIVE CODES' retained, the orange lamp will flash a code. If there is more than one code retained, there will be a short delay or the red lamp will flash once, between codes.
 - When the test is complete, the red lamp will flash three times.
- 5 Set the start switch to the 'OFF' position.

The diagnostic tool

General description

26A-3

The diagnostic tool has a display (A1), which shows information to the user.

During the operation procedures in this section, the information which is shown on the display will be represented by the illustration below:

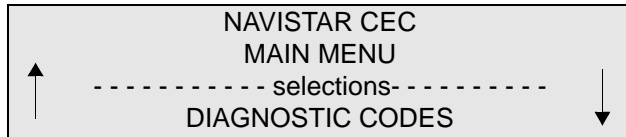

The display can show a maximum of four lines of text.

It may also show some arrows.

↑ ↓ These arrows (A10) indicate that more information is available, press the scroll-up key (A2) or the scroll-down key (A3) to obtain it.

← → This arrow (A9) indicates that more information is available, press the scroll-right key (A4) or the scroll-left key (A5) to obtain it.

The tool has 6 control keys, in the text these will be represented by the following symbols:

- ▲ Scroll-up key (A2)
- ▼ Scroll-down key (A3)
- ▶ Scroll-right key (A4)
- ◀ Scroll-left key (A5)
- FUNC Change-function key (A6)
- ENTER Enter key (A7).

There are keys marked 0 to 9 which are used to enter values.

There is also a button (A8) in the side of the tool, this is used to test all output circuits.

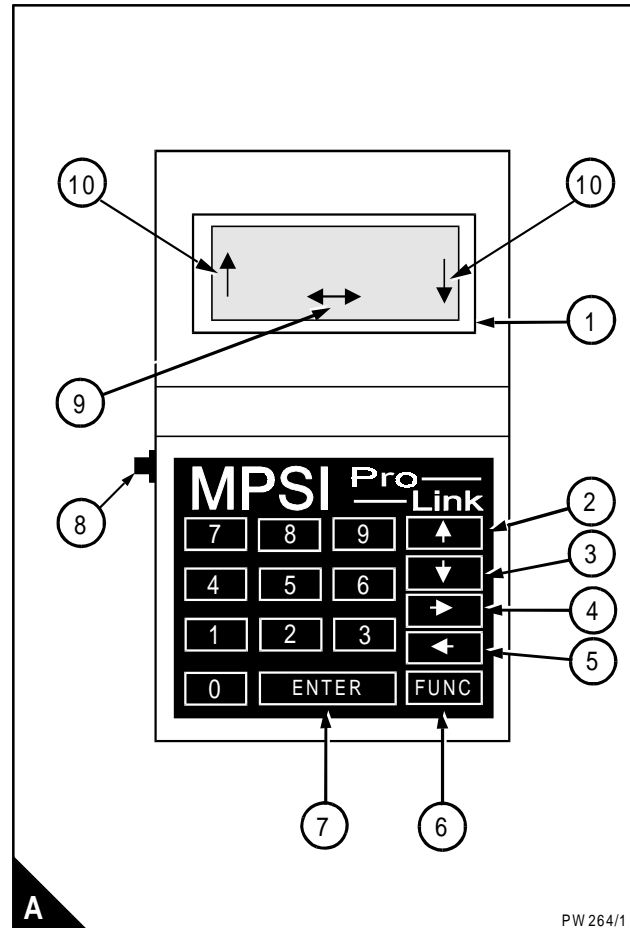

A

PW 264/1

The diagnostic program map

26A-4

The program map on the opposite page shows the contents of the Navistar CEC directory.

It is not possible to go directly from one item on the map to another unless they are connected by one of the symbols shown in the table opposite.

Use the map to move from test to test e.g. to move from "ENGINE DATA LIST" to "ACTIVE FAULTS":

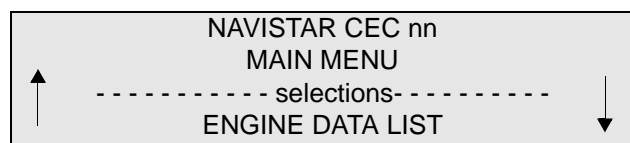

1 Press **▼**. "DIAGNOSTIC CODES" shows on the display.

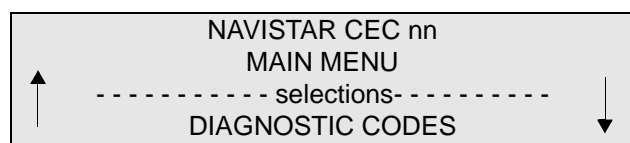

2 Press **ENTER**

The first option that will show is "ACTIVE CODES".

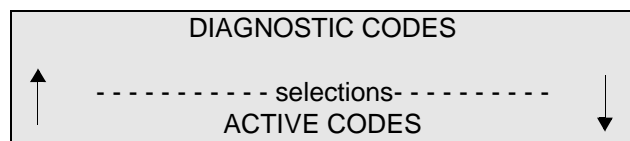

To return to "ENGINE DATA LIST".

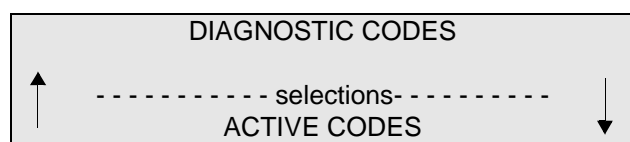

1 Press **FUNC**

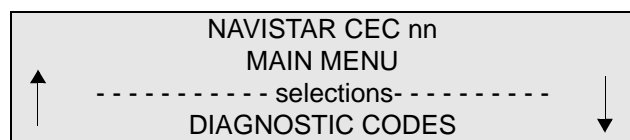

2 Press **▲**

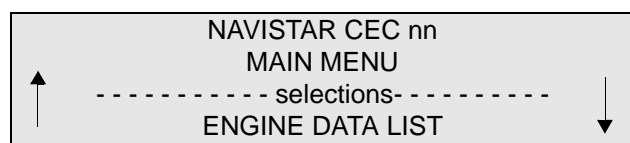

During some tests it will be necessary to chose between options shown on the display. One of the options will have parentheses [] around it e.g.

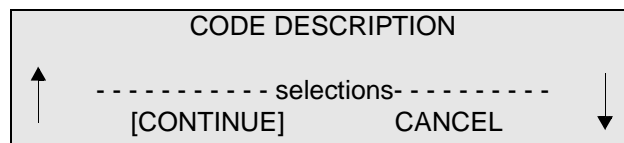

To select this option, press **ENTER**. To change to the other option, press **▶**

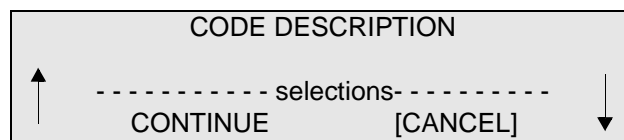

The parentheses [] will move, then press **ENTER**

Program map

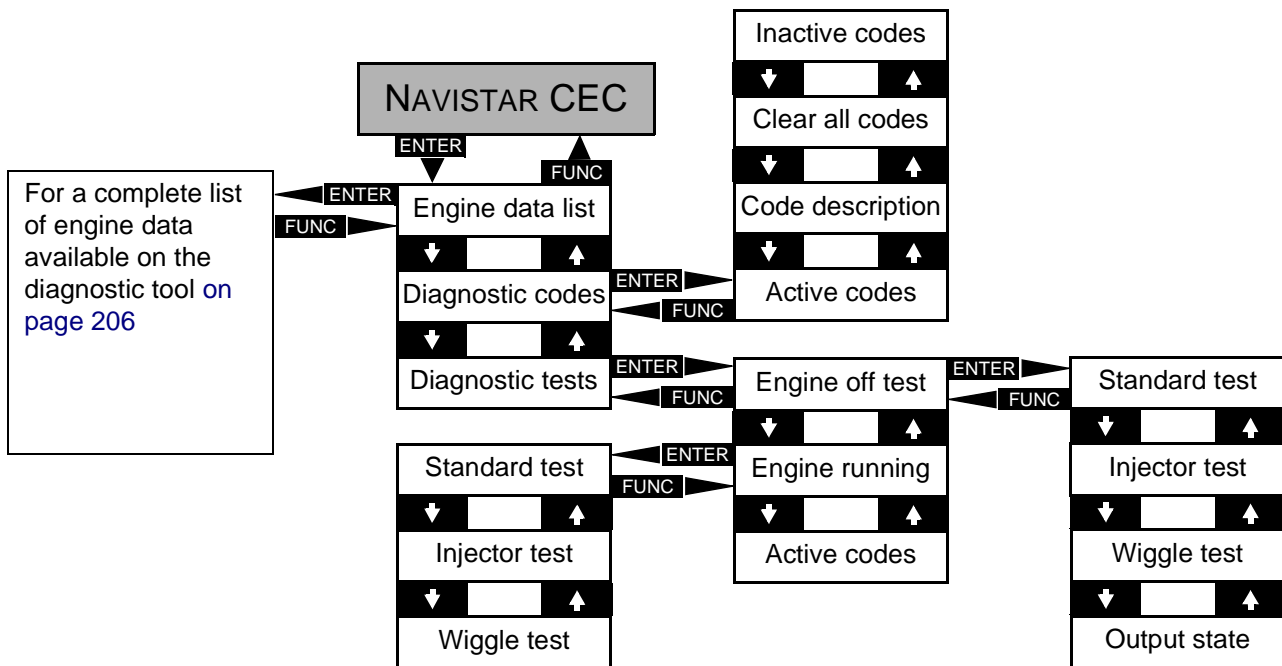

Symbol	Description
	Press ENTER to move to the item in the box below
	Press ENTER to move to the item in the box to the right
	Press ENTER to move to the item in the box to the left
	Press FUNC to move to the item in the box above
	Press FUNC to move to the item in the box to the right
	Press FUNC to move to the item in the box to the left
	Press ↓ to move to the item in the box below
	Press ↑ to move to the item in the box above

Code display options**26A-5**

The “CODE DESCRIPTION” menu allows a choice of two options:

- Navistar
- J1587

Navistar is the usual option needed. J1587 is for use in the United States of America.

To change the “CODE DESCRIPTION” option:

1 Move through the programme until “CODE DESCRIPTION” shows on the display, [see operation 26A-4](#).

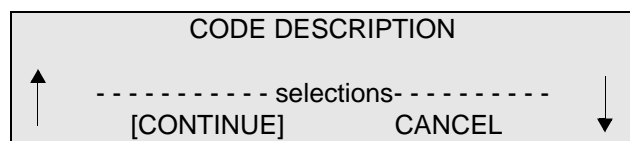

2 Press **ENTER**

The engine data list

26A-6

There are 61 items in the "DATA LIST". These can be used to check engine settings, performance and identification.

Only four items from the "DATA LIST" may be shown on the display at the same time.

The display can show either imperial or metric units. To change the display from one to the other, move to:

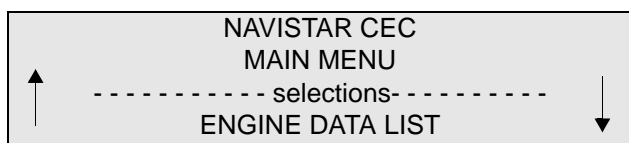

Press **▼** until "ENGLISH METRIC" appears on the display. Press **▶** or **◀** to put the parentheses around the correct unit of measure. Press **ENTER**

The data list

"RATED HORSEPOWER" is the rated output of the engine.

"RATED REV/MIN" is the rated speed of the engine.

"ACTIVE CODES" is a fault which was found by the engine control module and has not been corrected.

"INACTIVE CODES" is one which was an "active fault" at some time but is not present now. this could be because it was corrected, or it is an intermittent fault.

"ENGINE HOURS" is the total number of hours that the engine has operated.

"TOTAL MILES" is the total number of miles travelled by the application.

"TOTAL FUEL USED GAL"

"BATTERY" is the voltage value of the battery.

"ENGINE OIL TEMPERATURE" is the current temperature of the engine lubricating oil, in °F.

"INTAKE AIR TEMP"

"COOLANT TEMP"

"LOW IDLE SPEED"

"ACCEL. PEDAL %"

"ENGINE SPEED RPM" is the current speed of the engine, in revolutions per minute.

"BOOST PRESS. PSI" is the current boost pressure, in lbf/in².

"BARO PRESS PSI" is the current atmospheric air pressure, in lbf/in².

"TORQUE LIMIT %"

"ENGINE LOAD %"

"INJ CTRL CONTROL PRES." is the current pressure of the oil for injection control in the supply manifold, in lbf/in².

"FUEL RATE G/H" is the current fuel usage, in gallons per hour.

"TRANSSHAFT SPD RPM" is the current speed of the transmission shaft, in revolutions per minute.

"TWO SPEED AXLE"

"VEH SPEED MPH"

"IDL SHDN TMR STA"

"IDL SHDN TMR FUN"

"SHDN TMR OVR"

"DRIVER ALERT"

"AUX H2O PUMP PRES."

"VEH MAX. SPEED MPH"

"SPEED LIMIT"

"CRUISE SET SPEED MPH"

"CRUISE HIGH LMT MPH"

"CRUISE LO LMT MPH"

"CRUISE CTRL MODE"

"CC: CLUTCH SW"

"CC: BRAKE SW"

"CC: ACCEL SW"

"CC: RESUME SW"

"CC: COAST SW"

"CC: SET SW"

"CC: ON/OFF"

"COOLANT LEVEL %"

"ENG OIL PRES." is the current pressure of the engine lubricating oil, in lbf/in².

"ENG RTARD STAT"

"CYLINDER 6"

"CYLINDER 4"

"CYLINDER 3"

"CYLINDER 2"

"PTO SPEED"

"PTO CLUTCH SW"

"PTO BRAKE SW"

"PTO ACCEL SW"

"PTO RESUM SW"

“PTO COAST SW”

“PTO SET SW”

“PTO CNTRL MODE”

“PTO SET RPM”

“A/C DEMAND”

“TORQ CURVE SEL

“ ENG CRANK INHIB”

“CHNG OIL LAMP”

“RAD SHUT ENABLE”

“ENG FAN CTRL”

“REM VAR PTO SW”

“REM PRE PTO SW”

“REMOTE THROTTLE”

“HYDR PRES. GOV”

“HYDR PRES. MODE”

“RETARD ON/OFF”

“EXHAUST BACK PRES.”

“EPR DUTY CYCLE”

“IPR DUTY CYCLE”

“FUELING PW”

“EBP DESIRED PSI”

“ICP DESIRED”

“VIN” is the vehicle identification number.

“MAKE”

“MODEL ” is the model type of the engine.

“SW STRATEGY”

“ECM SW CALIB”

26A

How to connect the diagnostic tool 26A-7

- 1 Set the ignition switch to the 'OFF' position.
- 2 Connect the diagnostic tool to one end of the wiring loom supplied with the tool, then connect the other end of the wiring loom to the diagnostic connector on the application.

Note: The display of the tool should be illuminated as soon as the tool is connected to the application.

The following information will appear.

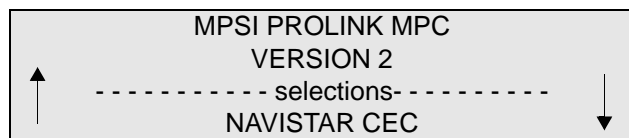

- 3 Set the ignition switch to the "ON" position, but do not start the engine.

Diagnostic codes

“DIAGNOSTIC CODES” has four sub-menus:

“ACTIVE CODES”

“INACTIVE CODES”

“CLEAR CODES”, see operation 26A-9.

“CODE DESCRIPTION”, see operation 26A-5.

How to check for faults codes

26A-8

“ACTIVE CODES”

Note: An “ACTIVE CODE” is one which was found by the engine control module and has not been corrected.

1 Move through the program until “ACTIVE CODES” shows in the display, see operation 26A-4.

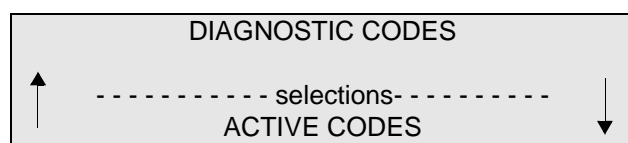

2 Press **ENTER**

- If there are no codes, “EMPTY” will show on the display:

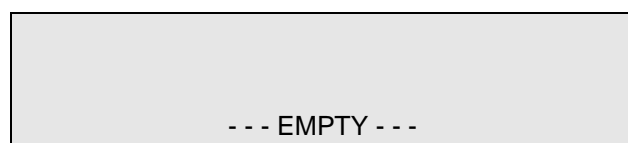

- If there is a code, it will show on the display, with a short description:

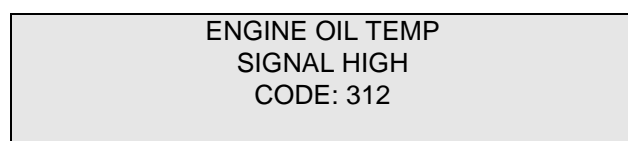

3 Record the fault.

- If there are no other codes, go to paragraph 6.
- If there are other codes, the scroll-up and scroll-down symbols will show on the display:

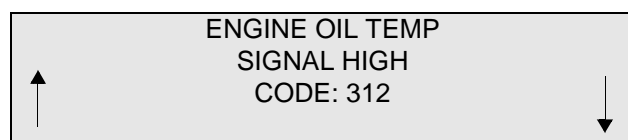

4 Press **↓** to obtain the other codes.

5 Record all the fault codes.

“INACTIVE FAULTS”

Note: An “INACTIVE FAULT” is one which was an “ACTIVE FAULT” at some time but is not present now. This could be because it was corrected, or it is an intermittent fault.

6 Move through the program until “INACTIVE CODES” shows on the display, see operation 26A-4.

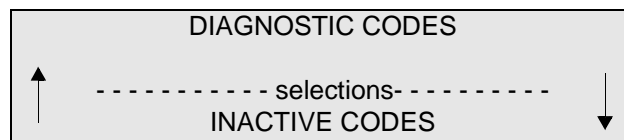

7 Press **ENTER**

- if there are no codes, “EMPTY” will show on the display.

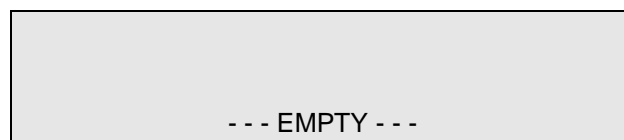

- If there is a code it will show on the display, with a short description e.g.

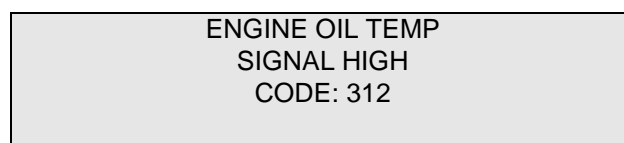

8 Record the fault.

- If there are no other codes, see operation 26A-9.
- If there are other codes the scroll-up and scroll-down symbols will show on the display e.g.

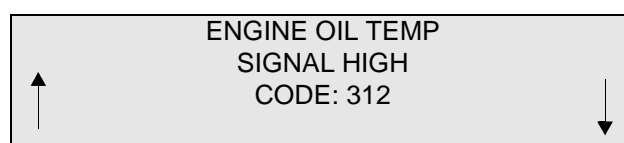

9 If the scroll symbols do show, press **↓** to obtain the other codes.

10 Record all the fault codes.

11 Correct all the faults.

12 Clear all the codes, see operation 26A-9.

26A

How to clear faults codes from the diagnostic tool

26A-9

When all recorded faults have been corrected, it is best to clear their codes from the memory of the ECM.

1 Move through the program until "CLEAR CODES" shows on the display, see operation 26A-4.

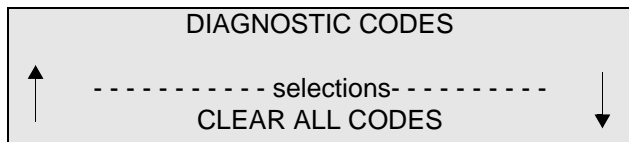

2 Press **ENTER**

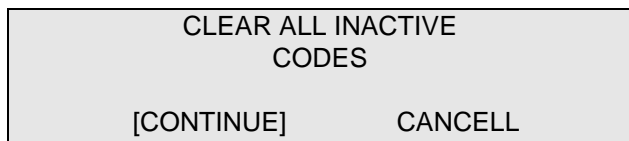

3 Press **ENTER**

When the codes have been removed, "EMPTY" will show on the display:

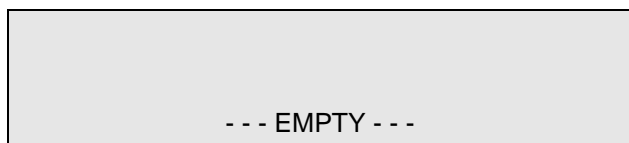

4 Press **FUNC**

Diagnostic tests

“DIAGNOSTIC TESTS” has three sub-menus:

“ENGINE OFF TEST”
 “ENGINE RUNNING TESTS”
 “ACTIVE CODES”.

Active codes can be obtained from this menu, see the program map.

How to do the “ENGINE OFF TEST” 26A-10

Engine off tests consists of four tests:

“STANDARD TEST”
 “INJECTOR TEST”
 “WIGGLE TEST”.
 “OUTPUT STATE TEST”.

Note: These tests must be done in the sequence that follows:

“STANDARD TEST”

1 Move through the program until “ENGINE OFF TESTS” shows on the display, see operation 26A-4.

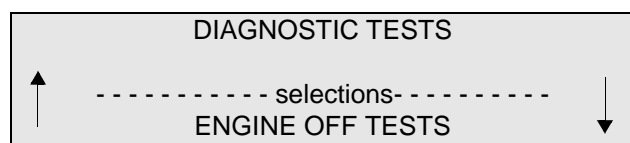

2 Press **ENTER**

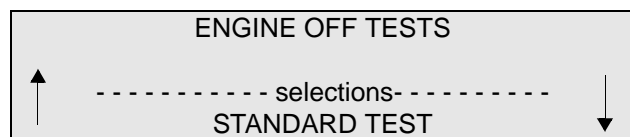

3 Press **ENTER**

When the test is complete:

- If there are no codes shown:

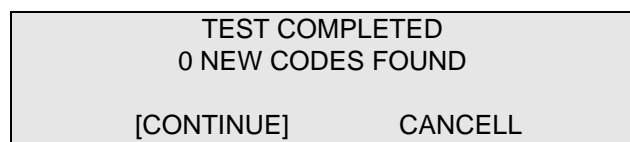

- If there are codes shown:

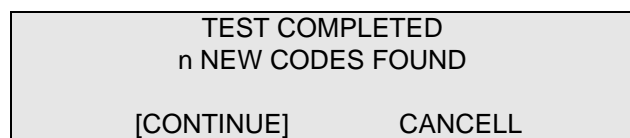

4 Press **ENTER** e.g.

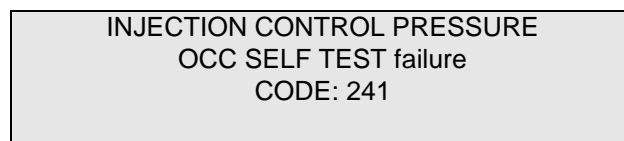

5 If the scroll symbols show, press **▼** to obtain the other codes.

6 Record all the fault codes.

“INJECTOR TEST”

7 Move through the programme until “INJECTOR TEST” shows on the display, see operation 26A-4.

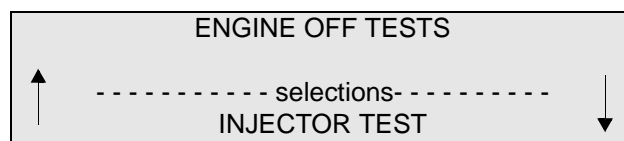

8 Press **ENTER**

The solenoids for the injector units will be energised in sequence. As each solenoid is energised a sound will be heard, ensure that the sound is heard from each solenoid.

When the test is complete:

- If there are no codes shown:

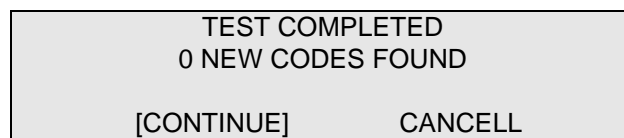

- If there are codes shown:

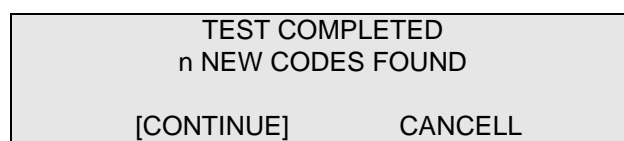

9 Press **ENTER** e.g.

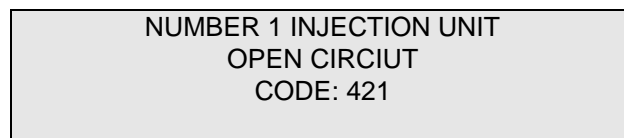

10 If the arrows show, press **▼** to obtain the other codes.

11 Record all the fault codes.

26A

“WIGGLE TEST”

12 Move through the program until “WIGGLE TEST” shows on the display, [see operation 26A-4](#).

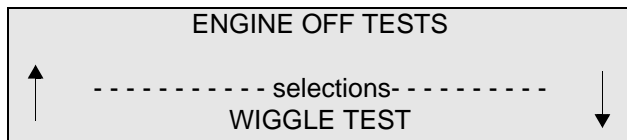

13 Press **ENTER**



14 Move each electrical cable and connector up and down and from side to side to test for faulty connections.

- If a fault occurs, a sound will be heard and the tool the display will alter to show “BEEP” and “NEW CODES 1”. Press **ENTER** e.g.

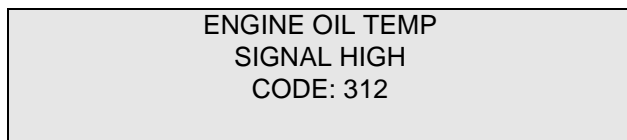

- When all the cables and connections have been tested, and corrected if necessary, press **ENTER**

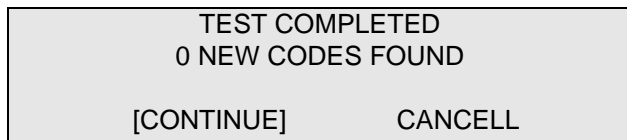

15 Press **ENTER**

“OUTPUT STATE TEST”

16 Move through the program until “OUTPUT STATE TEST” shows on the display, [see operation 26A-4](#).

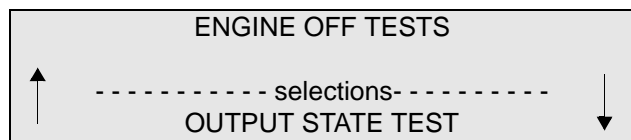

17 Press **ENTER**

- If there are no faults:



- If there are faults:

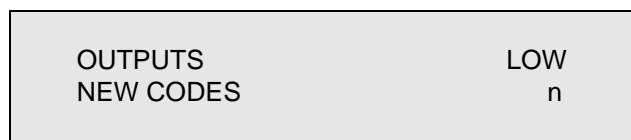

18 Press **ENTER** e.g.

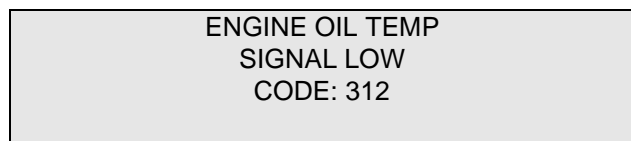

19 If the arrows show, press **▼** to obtain the other codes.

20 Record all the fault codes.

21 Press **ENTER**

22 Press the button on the left side of the tool to test for outputs “HIGH”. Repeat the “OUTPUTS STATE TEST”, [go to paragraph 17 to paragraph 21](#).

23 When the test is complete, record all the fault codes. Press **ENTER**

24 Correct all the faults.

25 Clear all the faults codes from the memory of the ECM, [see operation 26A-9](#).

How to do the "ENGINE RUNNING TEST" 26A-11

Before this test is done, check first for faults codes, see operation 26A-1, and do the "ENGINE OFF TEST", see operation 26A-10. This will assist with fault diagnosis.

"ENGINE RUNNING TEST" consists of three tests:

- "STANDARD TEST"
- "INJECTOR TEST"
- "WIGGLE TEST".

Note: These tests must be done in the sequence that follows.

"STANDARD TEST"

- 1 Start the engine, and run it until the normal temperature of operation is obtained.
- 2 Move through the program until "ENGINE RUNNING TESTS" shows in the display, see operation 26A-4.

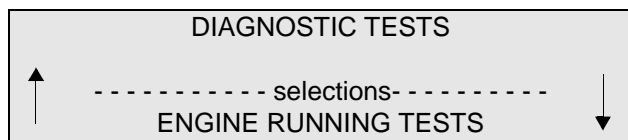

- 3 Press **ENTER**

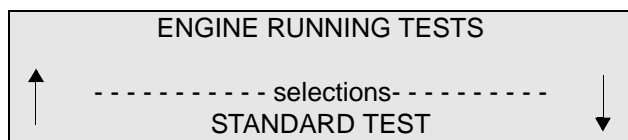

- 4 Press **ENTER**



When the test is complete:

- If there are no codes show:

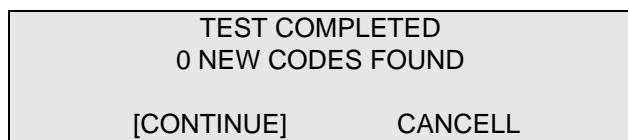

- If there are codes show:

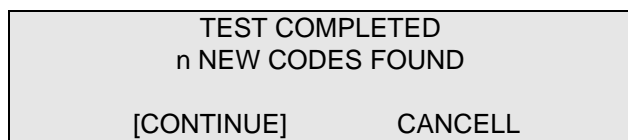

Press **ENTER** e.g.

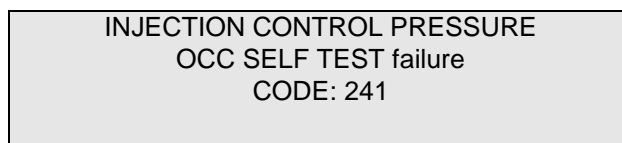

If the scroll symbols appear, press **↓** to obtain the other codes.

- 5 Record all the fault codes.

"INJECTOR TEST"

- 6 Press **↓**

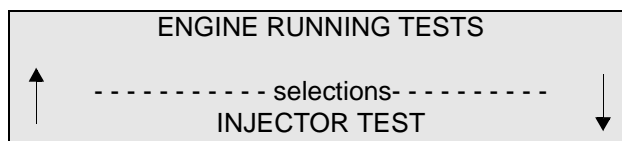

- 7 Press **ENTER**

Continued

26A

“WIGGLE TEST”

8 Press 

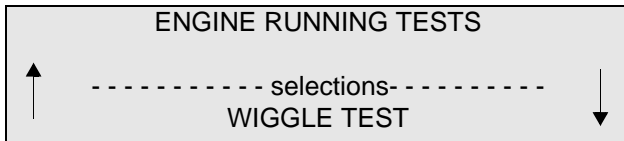

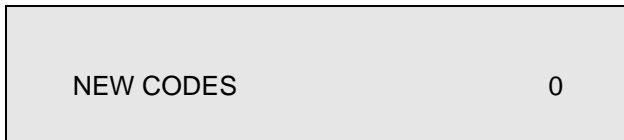

9 Press 



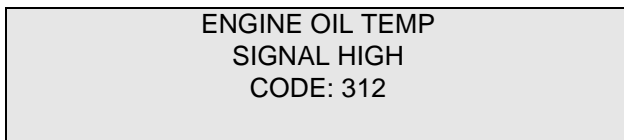

10 Move each electrical cable and connector up and down and from side to side to test for faulty connections.

- If a fault occurs, a sound will be heard and the tool the display will alter to show “BEEP” and “NEW CODES 1”. Press  e.g.

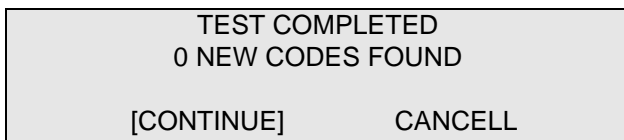

- When all the cables and connections have been tested and, if necessary, corrected, press 



11 Press 

12 Repair all the faults.

13 “CLEAR ALL FAULTS CODES”, [see operation 26A-9](#).

Flash codes

Flash code	Condition description	Comments	Probable causes
111	No errors found	-	-
112	Electrical system voltage B+ out of range: high	ECM voltage is continuously more than 18v	Charging system fault
113	Electrical system voltage B+ out of range: low	ECM voltage is continuously less than 6.5v. Cause of no start / misfire	Low battery voltage. Loose connections. High resistance in circuit
114	Engine coolant temperature signal out of range: low	Defaults to 180 °F (82 °C). Signal voltage less than 0.127v	Short circuit to earth
115	Engine coolant temperature signal out of range: high	Defaults to 180 °F (82 °C). Signal voltage greater than 4.6v	Open circuit. Sensor failure
121	Manifold air pressure signal out of range: high	Defaults to ECM setting. Low power. Slow acceleration. Signal voltage greater than 4.6v	Sensor failure
122	Manifold air pressure signal out of range: low	Defaults to ECM setting. Low power. Slow acceleration. Signal voltage greater than 4.6v	Short circuit to earth. Sensor failure
123	Manifold air pressure fault: in range	Defaults to ECM setting. Low power. Slow acceleration	Hose or sensor for manifold air pressure blocked
124	Injection control pressure signal out of range: low	Defaults to open-loop control. Underrun at low idle. Signal voltage less than 0.039v	Short circuit to low. Open circuit. Sensor failure
125	Injection control pressure signal out of range: high	Defaults to open loop control Underrun at low idle. Signal voltage greater than 4.897v	Short circuit to high. Sensor failure
131	Speed control signal out of range: low	Signal voltage less than 0.152v Engine at low idle only	Short circuit to earth. Open circuit. Sensor failure.
132	Speed control signal out of range: high	Signal voltage greater than 4.55v. Engine idle only	Short circuit to reference voltage or 12 volts. Sensor failure
133	Speed control signal fault: in range	Speed control position does not match the idle validation switch. Kept to 0% of Speed control position	Speed control failure
134	Speed control position does not match the idle validation switch	Kept to 0% of Speed control position	Speed control and idle validation switch failure
135	ECM low idle validation switch circuit faulty	Speed control position does not match the idle validation switch. Kept to 50% of Speed control position. Engine speed limited	Idle validation switch failure
141	Vehicle speed signal out of range: low	Speed sensor signal is less than 0.48v (0 Km/h/mph). Cruise control nor PTO not engaged. Engine speed limited	Sensor open circuit or short circuit to earth
142	Vehicle speed signal out of range: high	Speed sensor signal is greater than 4.492v (0 Km/h/mph). Cruise control nor PTO not engaged	Short circuit to reference voltage or 12 volts
143	Wrong number of pulses per revolution from the camshaft position sensor	Intermittent signal	Poor connection or camshaft position sensor failure

Flash code	Condition description	Comments	Probable causes
144	Interference found at the camshaft position sensor	ECM found excessive external inputs	Interference. Injector unit voltage short circuit to earth
145	No signal from the camshaft position sensor but the injection control pressure has increased	Found by the ECM	Short circuit to earth. Open circuit. Sensor failure
151	Barometric pressure signal out of range: high	Signal voltage greater than 4.9v for more than 1 second. Defaults to 101 kPa (14.7 lbf/in ²) 1,0 kgf/cm ²)	Short circuit high or open circuit. Sensor failure
152	Barometric pressure signal out of range: low	Signal voltage less than 1.0v for more than 1 second. Defaults to 101 kPa (14.7 lb/in ²) 1,0 kgf/cm ²	Short circuit to earth low
154	Intake air temperature signal out of range: low	Signal voltage less than 0.127v. Defaults to 170 °F (77 °C)	Short circuit to earth
155	Intake air temperature signal out of range: high	Signal voltage greater than 4.6v. Defaults to 170 °F (77 °C)	Open circuit
211	Engine oil pressure signal out of range: low	Signal voltage less than 0.039v	Short circuit to earth low
212	Engine oil pressure signal out of range: high	Signal voltage greater than 4.9v	Short circuit to earth high or open circuit
213	Remote speed control out of range: low	Remote speed control signal less than 0.249v	Open circuit
214	Remote speed control out of range: high	Remote speed control signal greater than 4.5v	Short circuit to earth
221	Cruise / PTO (or remote PTO) switch fault	Signal voltage incorrect, does not match the switch position	Short circuit or high resistance in the speed control circuit
222	Brake switch circuit fault	Voltage to pins 43 and 44 on the ECM are not the same	Switch or relay faulty or incorrectly adjusted
225	Sensor for engine oil pressure faulty: in range	Signal greater than 276 kPa (40 lbf/in ²) 2,8 kgf/cm ² with the engine start key in the "ON" position. Engine protection disabled	Faulty circuit connection. Sensor failure
231	ATA data link fault	ATA link open or short circuit. VPM fault	ATA device earthed or overloaded
236	Engine coolant level switch fault	-	Short circuit to earth or open circuit
241	Regulator for injection control pressure failed the output circuit test	Output circuit test in engine-off test only	Open circuit or short circuit to earth
244	Engine data link failed open circuit test	Output circuit test in engine-off test only	Open circuit or short circuit to earth
254	Open circuit test out of range: high	-	High voltage during open circuit test
255	Open circuit test out of range: low	-	Low voltage during open circuit test
311	Engine oil temperature signal out of range: low	Signal voltage less greater 4.8v Defaults to 212 °F (100 °C) No fast idle	Short circuit to earth

Flash code	Condition description	Comments	Probable causes
312	Engine oil temperature signal out of range: high	Signal voltage less than 0.2v Defaults to 212 °F (100 °C) No fast idle	Open circuit
313	Engine oil pressure below warning level	Oil warning light on	No oil or low oil level. Faulty regulator. Suction pipe blocked or damaged. Worn main bearings. Worn oil pump.
314	Engine oil pressure below critical level	Engine will stop, if this option is fitted	No oil or low oil level. Fault in regulator. Suction pipe blocked or damaged. Worn main bearings. Worn oil pump.
315	Engine speed exceeded warning limit	ECM recorded an engine speed greater than 3000 rev/min	Incorrect use of gears in automotive application
321	Engine coolant temperature above warning level	Coolant temperature greater than 224.6 °F (107 °C)	Cooling system fault
322	Engine coolant temperature too high	Coolant temperature greater than 233.6 °F (112.5 °C)	Cooling system fault
323	Engine coolant level below warning level	ECM finds low coolant level	Coolant level low. Leakage of coolant
325	Power reduced to match cooling system performance	Engine power reduced	High altitude or high ambient temperature
331	Injection control pressure too high	Injection control pressure above 25 Mpa (3675 lbf/in ²) 2250 kgf/cm ²	Short circuit to earth. Regulator valve stuck
332	Injection control pressure above specification with the engine off	Sensor signal voltage higher than expected with the engine off	Short circuit to voltage. Sensor fault
333	Injection control pressure below best value	Pressure does not match the output signal for a long period of time	Incorrect specification lubricating oil. Air in the lubricating oil. Leakage at the 'O' ring for the injector unit. Regulator fault.
334	Injection control pressure does not reach the correct pressure in the time allowed	Pressure does not match the output signal for a short period of time	Incorrect specification lubricating oil. Air in the lubricating oil. Leakage at the 'O' ring for the injector unit. Regulator fault.
335	Injection control pressure does not increase during engine cranking	Less than 5,1 MPa (725 lbf/in ²) 51 kgf/cm ² after 10 seconds of cranking	Air in the lubricating oil. Fault in the high -pressure lubricating oil system
336	Injection control pressure does not reach the correct pressure	-	A leakage of lubricating oil or fault in the high -pressure lubricating oil system
421	Number 1 injector unit open circuit: high or low	Found by the ECM	Injector unit electrical wiring loom open circuit
422	Number 2 injector unit open circuit: high or low	Found by the ECM	Injector unit electrical wiring loom open circuit
423	Number 3 injector unit open circuit: high or low	Found by the ECM	Injector unit electrical wiring loom open circuit
424	Number 4 injector unit open circuit: high or low	Found by the ECM	Injector unit electrical wiring loom open circuit

Flash code	Condition description	Comments	Probable causes
425	Number 5 injector unit open circuit: high or low	Found by the ECM	Injector unit electrical wiring loom open circuit
426	Number 6 injector unit open circuit: high or low	Found by the ECM	Injector unit wiring loom open circuit
431	Number 1 injector unit short circuit: high or low	Found by the ECM	Injector unit electrical wiring loom shorted high to low
432	Number 2 injector unit short circuit: high or low	Found by the ECM	Injector unit electrical wiring loom shorted high to low
433	Number 3 injector unit short circuit: high or low	Found by the ECM	Injector unit electrical wiring loom shorted high to low
434	Number 4 injector unit short circuit: high or low	Found by the ECM	Injector unit electrical wiring loom shorted high to low
435	Number 5 injector unit short circuit: high or low	Found by the ECM	Injector unit electrical wiring loom shorted high to low
436	Number 6 injector unit short circuit: high or low	Found by the ECM	Injector unit electrical wiring loom shorted high to low
451	Number 1 injector unit short circuit to B+ or earth: high	Found by the ECM	Injector unit electrical wiring loom shorted to earth: low
452	Number 2 injector unit short circuit to B+ or earth: high	Found by the ECM	Injector unit electrical wiring loom shorted to earth: low
453	Number 3 injector unit short circuit to B+ or earth: high	Found by the ECM	Injector unit electrical wiring loom shorted to earth: low
454	Number 4 injector unit short circuit to B+ or earth: high	Found by the ECM	Injector unit electrical wiring loom shorted to earth: low
455	Number 5 injector unit short circuit to B+ or earth: high	Found by the ECM	Injector unit electrical wiring loom shorted to earth: low
456	Number 6 injector unit short circuit to B+ or earth: high	Found by the ECM	Injector unit electrical wiring loom shorted to earth: low
451	Number 1 injector unit short circuit to earth	Found by the ECM	-
452	Number 2 injector unit short circuit to earth	Found by the ECM	-
453	Number 3 injector unit short circuit to earth	Found by the ECM	-
454	Number 4 injector unit short circuit to earth	Found by the ECM	-
455	Number 5 injector unit short circuit to earth	Found by the ECM	-
456	Number 6 injector unit short circuit to earth	Found by the ECM	-
461	Number 1 injector unit failed the contribution test	Found by the ECM	-
462	Number 2 injector unit failed the contribution test	Found by the ECM	-
463	Number 3 injector unit failed the contribution test	Found by the ECM	-
464	Number 4 injector unit failed the contribution test	Found by the ECM	-
465	Number 5 injector unit failed the contribution test	Found by the ECM	-

Flash code	Condition description	Comments	Probable causes
466	Number 6 injector unit failed the contribution test	Found by the ECM	-
513	Bank 1 open circuit: low	Injector units for cylinders 1,2 and 3 have an open circuit in the high voltage supply	Open circuit
514	Bank 2 open circuit: low	Injector units for cylinders 4, 5 and 6 have an open circuit in the high voltage supply	Open circuit
515	Bank 1 short circuit to earth or B+: low	Injector units for cylinders 1,2 and 3 have short circuit to earth or B+	Short circuit in wiring loom
521	Bank 2 short circuit to earth or B+: low	Injector units for cylinders 4, 5 and 6 have short circuit to earth or B+	Short circuit in wiring loom
524	Short circuit between bank 1 and bank 2	Short circuit between bank 1 and bank 2	Short circuit in wiring loom
525	Injector unit driver circuit fault	ECM unable to supply sufficient voltage to injector units	Engine wiring loom fault. Injector unit wiring loom fault. ECM fault
612	Incorrect ECM installed for the camshaft timing plate	No match between the ECM and the camshaft position sensor	Incorrect ECM fitted
614	Engine family rating code and ECM do not match	ECM programming fault	Components not compatible
621	Engine using default rating	Engine operates AL25 HP, default	ECM installed but not programmed
622	Engine using field default rating	Engine limited to 160 HP Options not available	ECM installed but not programmed
623	Invalid engine rating code	-	ECM not programmed correctly
624	Field default active	Programming problem	ECM fault
625	ECM fault	ECM software fault	Replace ECM
626	Unexpected ECM reset fault	Temporary ECM power failure	Battery connection fault
631	ROM self test fault	ECM failure	Internal ECM fault
632	RAM self test fault	ECM failure	Internal ECM fault
655	Programmable parameter list level incompatible	Programming problem. ECM memory problem	Programming fault
661	RAM programmable parameter list corrupt	Programming problem ECM memory problem	Programming fault
664	Calibration level incompatible	Programming problem	Programming problem
665	Programmable parameter memory content corrupt	ECM failure	Internal ECM fault

