

WORKSHOP MANUAL

'C-RH' ENGINES

T.S.D. Publication 3152
(1st Issue)

December 1981

Printed in England

NOTES TO USERS

This publication refers to the 'C-RH' build of engines currently being built to the following specifications:

C6-86G	C6-101G	C6-160G
C6-88G	C6-130G	C6-200G

All 'C-RH' engines have the camshaft built into the right-hand side of the crankcase, viewed from the rear. The fuel injection pump, which is mounted on the opposite side, gives external identification of this type of engine build.

The purpose of this Manual is to provide Operators with all information necessary for complete overhaul of Rolls-Royce 'C-RH' engines. For information concerning routine servicing refer to the Servicing Manual T.S.D. 3126.

Operators are strongly recommended to make use of the following services and facilities available to them:

Service

The Equipment Manufacturers and their appointed Distributors carry an approved stock of spares and have staff trained and certificated by Rolls-Royce Motors Limited. They are supported where necessary by the area-based Rolls-Royce engineer who is always available for consultation.

To assist Operators in reducing 'down time' to a minimum, Rolls-Royce Motors Limited have instituted a Service Exchange Scheme so the Equipment Manufacturers and their Distributors can speedily supply a replacement engine or major component, fully reconditioned at the Factory and guaranteed for six months. Units available are listed overleaf.

Advice and assistance can be provided more efficiently and with minimal delay if enquiries are accompanied by the following information:

- (1) In all cases, the engine Number and Designation, as stamped on the crankcase data plate (see Frontispiece for location), and the total number of E.S.C. Units recorded.
- (2) If a proprietary unit (e.g. injection pump, turbocharger) is involved, the details on its data plate, and total E.S.C. Units if different from (1).
- (3) Any other information logically connected with the subject, e.g. type of fuel, lubricating oil or coolant used; details of service history, etc.

Instruction

Two-day and five-day courses on servicing and overhaul of 'C-RH' engines are available at the Factory. For details apply to: The Superintendent, Customer Training Centre, Rolls-Royce Motors Limited, Shrewsbury.

Service Instructions and Bulletins

Service techniques and engine design are under constant review at Rolls-Royce, so that from time to time it becomes necessary to revise Manuals and allied publications to include the results of this development work. Between revisions, all concerned are provided with full details of changes as they occur, the information being produced in leaflet form and sent in bulk to Equipment Manufacturers for onward transmission to Distributors and Operators as necessary:

- (1) Changes in Service Techniques are issued as Service Instructions (S.I's) for inclusion in Servicing Manuals held by Distributors and Operators.
- (2) Engine design changes are published, usually as Modifications, in Service Bulletins (O.E.B's) for information of Equipment Manufacturers and Distributors.

Associated Technical Publications for 'C-RH' build Engines

T.S.D. 3126	Servicing Manual	T.S.D. 3124	Folder, 'Operator's Guide'
—	Parts manual (Identified by Engine Number and Designation)	T.S.D. 3137	Booklet, 'Essential information for the Operator'
T.S.D. 3085	Leaflet, Diesel fuel, lubricating oil and coolant recommendations	T.S.D. 3133	Wall Charts, illustrating cooling, fuel and lubrication systems
T.S.D. 810	Leaflets, 'Service Bulletins'	T.S.D. 3132	Wall Chart, 'Torque Loadings'
T.S.D. 965	Leaflets, 'Service Instructions'	T.S.D. 3134	Wall Chart, 'Servicing Schedules'

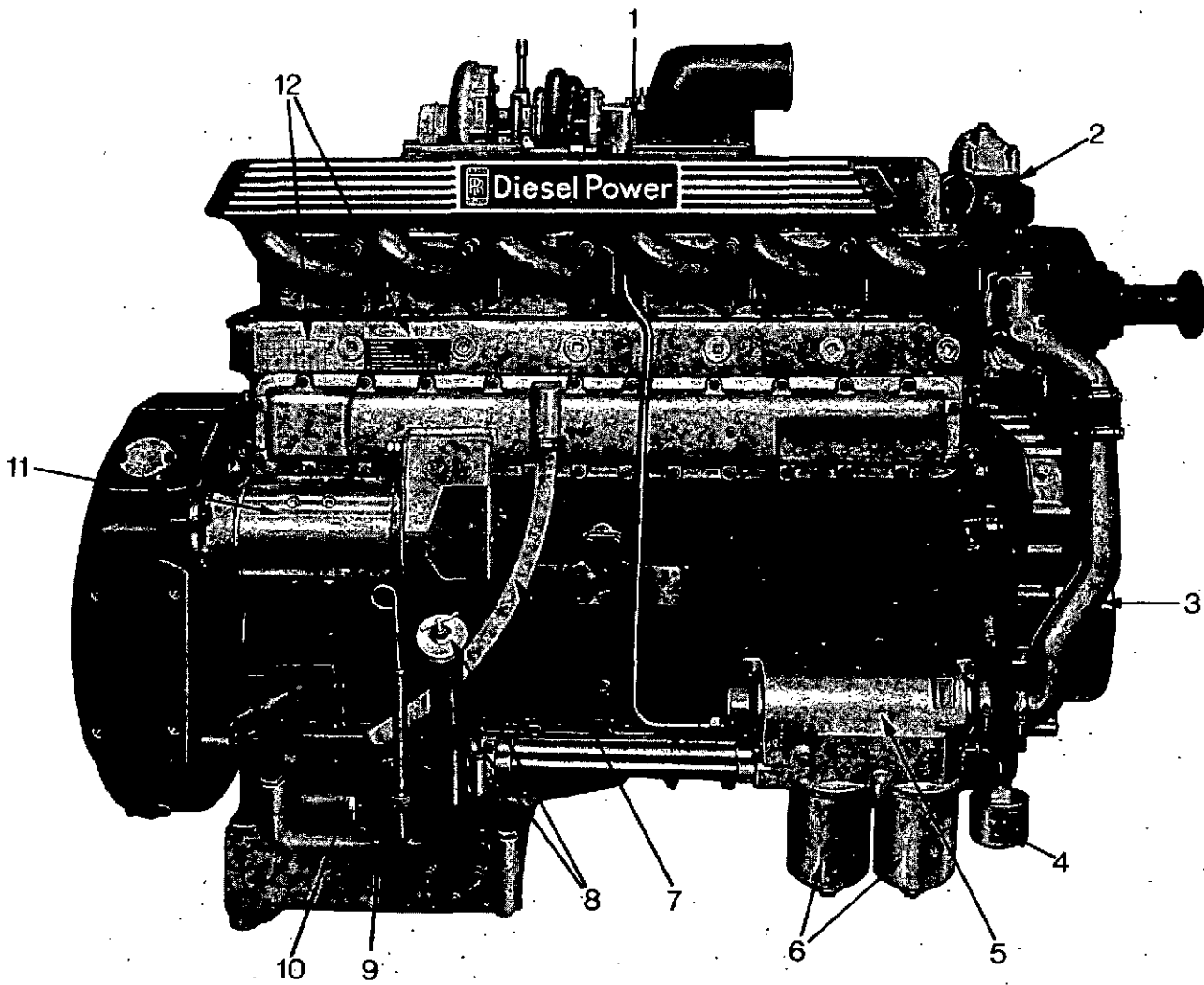

T720073

RIGHT-HAND VIEW OF ENGINE

- | | |
|--|----------------------------------|
| 1. Coolant temperature switch | 7. Crankcase breather pipe |
| 2. Thermostat housing | 8. Dipstick and oil filler |
| 3. Crankshaft damper and barring adaptor | 9. Oil pressure gauge connection |
| 4. Oil pressure switch | 10. Oil pressure relief valve |
| 5. Oil-to-coolant heat exchanger | 11. Starter motor |
| 6. Lubricating oil filters | 12. Engine data plates |

Printed in Great Britain

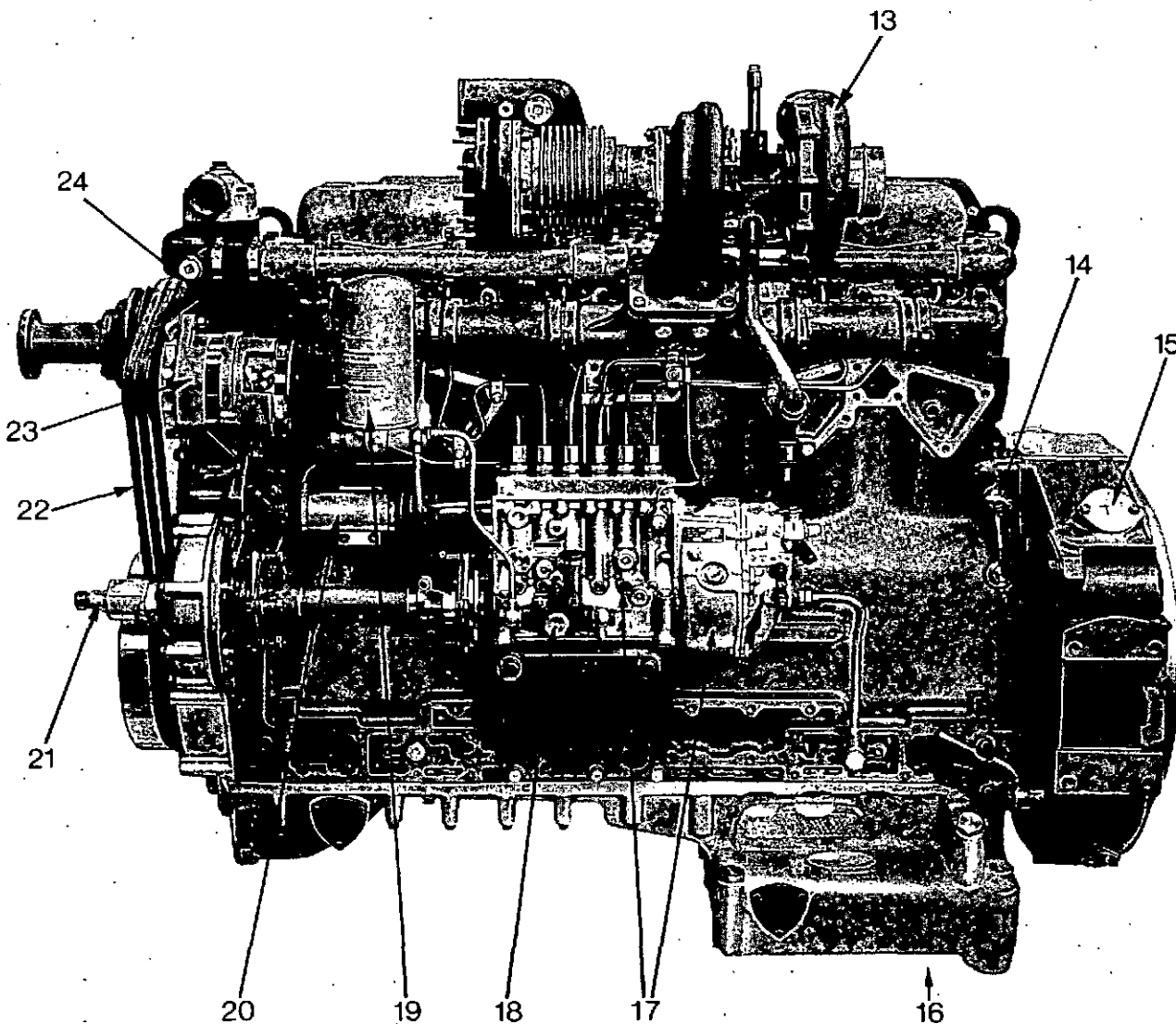

T720074

LEFT-HAND VIEW OF ENGINE

- | | |
|--------------------------------------|----------------------------|
| 13. Turbocharger | 19. Fuel filter |
| 14. Coolant drain tap | 20. Shutdown solenoid |
| 15. Timing pointer cover | 21. Engine Service Counter |
| 16. Sump drain plug | 22. Driving belts |
| 17. Fuel injection pump and governor | 23. Alternator |
| 18. Feed pump and priming pump | 24. Coolant pump |

SERVICE EXCHANGE SCHEME

The information in this Manual will assist the Operator to carry out any work, from minor repair to complete overhaul, on 'C-RH' engines but on occasions the personnel, equipment or time may not be available, resulting in delay before the unit returns to service.

Therefore, Rolls-Royce Motors Limited have instituted a Service Exchange Scheme so that Distributors and Dealers can speedily supply a replacement engine or major component, fully reconditioned at the Factory and guaranteed for six months. Prices are listed in Publication T.S.D. 3035E.

The units available through this Scheme are listed below. Further details may be obtained from Distributors and Dealers; all enquiries should quote the engine Number and Designation, as stamped on the data plates affixed to the crankcase above the starter. When applicable, the details on the data plate of a proprietary unit (e.g. turbocharger) should be included.

ENGINE (Complete)
 'SHORT ENGINE' (See illustrations)
 COOLANT PUMP
 CRANKSHAFT
 CYLINDER HEAD
 OIL PUMP

AIR COMPRESSOR
 ALTERNATOR
 INJECTORS
 INJECTION PUMP (Complete)
 STARTER MOTOR
 TURBOCHARGER

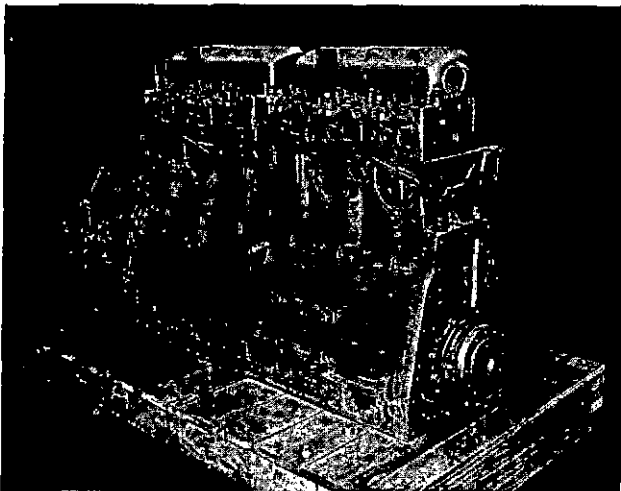

Fig. 1 Servex engine—L.H. view

T720075

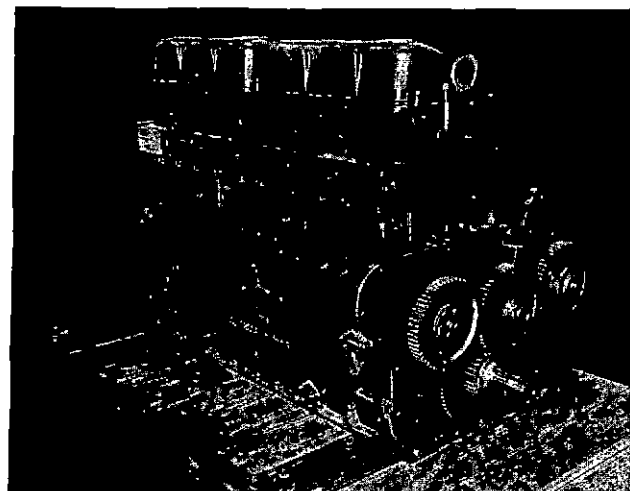

Fig. 2 Servex engine—R.H. view

T720076

CONTENTS

	Section
GENERAL INFORMATION.....	—
DESCRIPTION AND DATA.....	1
DISMANTLING THE ENGINE.....	2
ASSEMBLING THE ENGINE.....	3
CRANKCASE AND CYLINDERS.....	4
CAMSHAFT.....	5
CRANKSHAFT, MAIN BEARING AND FLYWHEEL.....	6
PISTONS AND CONNECTING RODS.....	7
CYLINDER HEADS AND VALVE GEAR.....	8
COOLING SYSTEM.....	9
FUEL SYSTEM.....	10
LUBRICATION SYSTEM.....	11
WHEELCASE AND GEARS.....	12
TURBOCHARGER.....	13
ELECTRICAL EQUIPMENT.....	14
RUNNING-IN AND STORAGE	15

GENERAL INFORMATION

The following information, if kept in mind during repair or overhaul work, will help to ensure that the engine returns to duty in first-class order and can be relied on to give long and trouble-free service, provided that it is properly used and maintained.

Cleanliness

The importance of this cannot be over-emphasised. Foreign matter such as dirt, metal swarf and fluff entering an engine may be sufficient to block fuel passages and oilways. Hard particles will damage bearing surfaces, producing quantities of metal fragments which continue the process. The results are faulty running, rapid wear and possible engine failure.

If an engine in service is to be partly dismantled for repair, first clean the vicinity of the component concerned. During dismantling, blank off all openings and disconnected pipes without delay, and protect each component against dirt and damage until it is refitted.

When reassembling, take care that foreign matter does not enter the engine. Ensure that the atmosphere is as dust-free as possible, and inspect each part immediately before it is fitted. Blow through all pipes and oilways with dry compressed air before making connections.

Special tools

These are provided for specific jobs and should be used, when recommended, to save time and prevent damage. A list of appropriate tools is given at the end of each Section.

Crack detection

Highly stressed components should be tested at overhaul or when they have been subject to shock or impact. Ferrous parts such as crankshafts, connecting rods and gearwheels are tested on an electro-magnetic

rig. For non-magnetic components such as valves and pistons a dye penetrant is suitable; a recommended process is Ardrex 996, available from Ardrex Limited, Commerce Road, Brentford, Middlesex.

Fits and clearances

At the end of each Section dealing with inspection and assembly of a component will be found a table of relevant fits and clearances. A part falling within the dimensions given is acceptable for a full period of service. Certain parts, if worn beyond limits, may be reconditioned under approved Service Reclamation Schemes which are circulated to authorised Dealers and Distributors.

Torque loadings

These are specified for certain setbolts and nuts where defect or failure could result from incorrect tightening. For certain joints (e.g. cylinder head to crankcase) it is also essential that tightening is done in the sequence given in the assembly instructions.

Locking devices

Split pins, tabwashers, and stiffnuts having fibre or nylon inserts should be used once only. All-metal stiffnuts may be re-used, provided that they offer noticeable resistance to movement against normal spanner leverage. At least one full thread should protrude through a stiffnut.

Joints, hoses and 'O' rings

It is false economy to re-use these items; their cost is trifling compared with the expense of rectifying leaks when the engine is back in service.

When making joints a non-setting compound such as 'Wellseal' is recommended for general use. Jointing compound should be applied thinly to avoid the possibility of oilways being obstructed by the excess.

To assist in fitting new hoses, use water, glycol or an approved rubber lubricant such as Carbowax 600 or Duckhams Q.4590. Never use mineral oil or grease, which are injurious to rubber.

Lightly coat 'O' rings with rubber lubricant to prevent 'trapping' during assembly.

Exchange units

Unserviceable units should be returned complete to the same build as the replacement, and protected against damage and corrosion.

Spares

To comply with the terms of the Rolls-Royce Motors Guarantee, **USE ONLY GENUINE ROLLS-ROYCE PARTS**, obtained from the Factory or an authorised Dealer. These parts fully conform to Rolls-Royce standards and are themselves guaranteed for six months.

The use of counterfeit spares, notably filter elements, may invalidate any current Guarantee and can seriously reduce engine life and performance.



SECTION 1—DESCRIPTION AND DATA

General

The 'C-RH' build engine is a development of the 'Eagle' automotive and 'C' range industrial engines with which it shares, to a great extent, the advantage of component rationalization.

The 6 cylinder in-line, charge-cooled, 4 stroke, compression ignition engine is pressure charged by a single turbocharger and has conventional liquid cooling.

The cylinder units are numbered 1 to 6 from the front (free) end to the rear (flywheel) end of the engine.

Data plates, affixed to the crankcase, are stamped with the Engine Number, Designation and Build Number.

Crankcase

The crankcase is cast in nickel-chrome iron as a monobloc unit and dipped in a special compound to seal all non-machined surfaces against contamination. Oilways are drilled to ensure cleanliness and uniformity.

The seven main bearing caps are of forged steel. The two outer and the central caps, being double width, are attached with four studs and nuts. The intermediate bearing caps are attached with two studs and nuts. Lateral setbolts, fitted through the crankcase walls, into the front, central and rear bearing caps give added rigidity to the crankcase.

Cylinder bores are machined to accept the push-fit 'wet' liners which are of centrifugally cast iron, differentially hardened and tempered. The liners are machined to fine tolerances with honed bores.

Crankshaft

The crankshaft is a chrome-molybdenum steel forging, fully machined and balanced, with all the bearing surfaces nitride hardened and lapped to size. Drillings in the shaft provide pressure lubrication to the seven main journals and the six crankpins, each crankpin being bored to form a centrifugal sludge trap, with removable sealing plugs.

Axial location is by steel-backed, lead-bronze, thrust-washers, carried in recesses machined on either side of the centre main bearing.

The seven main journals run in steel-backed, lead-bronze bearing shells, indium flashed on the bearing surfaces. Each half bearing being positioned by locating tangs pressed out from one end.

At the front end of the crankshaft, detachable gearing provides drive for the lubricating oil pump and main gear train whilst at the rear end, a flange with nine tapped holes and three dowel holes provides a mounting for the flywheel and starter ring assembly.

Pistons and connecting rods

The pistons are cast from high silicon aluminium alloy with the crowns machined to form open toroidal combustion chambers. Each piston carries three-compression and one oil control ring in machined grooves above the gudgeon pin. The top ring is carried in an austenitic iron insert. Ring sequence is as follows:

Top	—	Inlaid molybdenum surface
Second	—	Chrome plated
Third	—	Ferrox treated surface
Bottom	—	Composite chrome plated oil control ring.

Each piston is tin plated on all surfaces after machining apart from the gudgeon pin bore. The gudgeon pin, which is fully floating, is offset to the vertical axis of the piston and is retained by the conventional circlip method.

Connecting rods are forged from chrome-molybdenum steel and drilled longitudinally for pressure lubrication of the small end bearing. Small holes, drilled into the eye of each rod, provide cooling oil jets to the underside of the piston crown.

Two steel-backed, lead-bronze bushes, pressed into the small end eye, form the small end bearing, the big end bearing being steel-backed, lead-bronze half

shells, indium flashed on the inner surfaces. Location is by tangs pressed out at one end of each half bearing shell.

All connecting rods in a production engine are within a weight group of 4 ozs (113 grammes) range. Markings on each rod assembly give rod to cap correlation, weight and when allocated, the cylinder number.

Connecting rod big ends are designed to pass through the liner bore to facilitate overhaul procedures.

Camshaft

The camshaft is made of carborised steel. An oil gallery, bored axially through the shaft, is closed at the front end with an alloy plug and 'O' ring seal and at the rear end by a hexagon headed steel plug secured with a tab washer. Drillings in the periphery of each of the seven camshaft journals, direct pressurised oil to the bearing surfaces.

Five tapped and five dowel holes in the front end face of the camshaft are provided for securing the cam drive gear.

The seven journals run in the parent crankcase metal without conventional bushes. Axial location is by a thrust plate, bolted to the crankcase, bearing on a collar machined on the end of the camshaft front journal.

Pushrods and tappets

The pushrods are made from medium carbon steel bar, induction hardened, with a cup machined in the upper end. The lower end of the rod has a machine polished, spherical foot.

The tappets, made of cast iron alloy, are fully machined with chill-hardened bases and finally phosphate treated to provide an oil retaining finish.

Cylinder heads

Two identical cylinder heads in high duty, close grained cast iron, each covering three cylinders, are machined across the upper and lower faces for a close tolerance fit between the rocker gear cover and the cylinder block respectively. Machined joint faces accommodate the induction and exhaust manifolds on the side walls of each cylinder head. Internal coolant passageways are cast around the valve guides and injector pockets.

The cast iron valve guides are inserted under

pressure into each cylinder head casting. A 'ptfe' oil seal is fitted around the top of each exhaust valve guide. Valve seat inserts of chrome iron alloy, are frozen into position against shoulders machined into the cylinder flame face.

Two valves are fitted over each cylinder. The forged steel inlet valves have stellite seats and hardened stem tips. Exhaust valves are made of bi-metallic material with hardened stem tips, forged steel or Nimonic material. The forged steel exhaust valves have stellite seats and hardened stem tips, but differ from the inlet valves by having chambers part filled with sodium in their stems. Sodium filled valves are identified by a 'V' groove machined around the stem near the tip. Disposal of worn or damaged sodium filled valves is described in Publication S.I. 105. All valves in an engine have chrome flashed stems.

Each valve operates with double springs, in a conventional spring seat and collet arrangement, valve rotators being used in place of the lower spring seat on the exhaust valves.

Rocker gear

Each rocker shaft, supported by three pedestals on the cylinder head, is bored axially for oil transmission to the rocker arm bushes. A hole drilled longitudinally through each rocker arm provides lubricating oil to the contact faces between the rocker arm pad and valve stem tip at one end and the adjusting screw and pushrod at the other.

A cast aluminium rocker cover for each cylinder head is secured by eight setbolts, with an oil resistant gasket fitted between the joint faces.

Gear train

The wheelcase, mounted on the front (free) end of the engine, houses the gear train. The crankshaft pinion drives a large idler gear which, in turn, provides drive for the camshaft and auxiliary drive gears. The pinion, idler and both drive gears have machined spots on the front edge of the teeth, to enable correct engagement of the teeth to be made during engine build or overhaul.

A large narrow gear, directly behind the crankshaft pinion, meshes with the oil pump drive gear.

Fuel system

Fuel injection is by a plunger-type pump with individual elements, via multi-hole injectors direct

into open combustion chambers in the piston crowns. A mechanical governor is mounted on the rear of the injection pump with the complete unit being driven at 0.5 x engine speed and lubricated by oil from the main engine system. The feed pump is of the spring-loaded plunger type, mounted on the injection pump and operated by a double eccentric on the fuel pump camshaft.

Lubrication system

Lubricating oil is drawn from the sump by a spur-gear pump driven from a gear-wheel behind the crankshaft pinion, and is delivered at controlled

pressure via a heat exchanger and full-flow filters to the main bearings and thence throughout the engine, returning to the sump by gravity.

Cooling system

The approved coolant is a mixture of inhibited ethylene glycol and clean drinking water circulated by a belt driven pump to which is fitted a cooling fan. A triple-element wax-capsule thermostat, with radiator by-pass, ensures rapid warming up and an oil-to-coolant heat exchanger maintains the lubricating oil at a constant temperature.

GENERAL ENGINE DATA

TYPE Vertical, 6-cylinder, in-line, liquid-cooled
 4-stroke diesel, turbocharged, charge cooled

BORE 5.125 inches (130.17 mm)

STROKE 6.000 inches (152.4 mm)

CAPACITY (Swept volume) 742.64 cu. inches (12.17 litres)

COMPRESSION RATIO: Normally aspirated 16 to 1
 Turbocharged 15 to 1

VALVE TAPPET CLEARANCE
 (Engine stopped, hot or cold)

Inlet 0.015 inch (0.38 mm)
Exhaust 0.025 inch (0.63 mm)

FUEL INJECTION TIMING As stamped on engine data plate

CYLINDER NUMBERING From front to rear

ENGINE FIRING ORDER 1, 4, 2, 6, 3, 5

DIRECTION OF ROTATION Anti-clockwise, viewed on flywheel

DRY WEIGHT (Approximate)

Bare engine 2950 lb (1340 kg)
Engine radiator unit 3460 lb (1570 kg)

COOLING SYSTEM

APPROVED COOLANTS See leaflet T.S.D. 3085 in rear cover pocket

CAPACITY (Engine/radiator unit) 15.5 Imp. galls (70.5 litres)

SYSTEM PRESSURE 7 to 10 lbf./sq. inch (50 to 70 kN/sq.m.)

OPERATING TEMPERATURE (At sea level)

Normal 90 deg. C
Maximum intermittent 95 deg. C

THERMOSTAT Western-Thomson, triple-element wax capsule type
 with radiator by-pass

OIL-TO-COOLANT HEAT EXCHANGER See 'Lubrication System'

SYSTEM CLEANING COMPOUNDS

I.C.I. Ltd. Lissapol 'N', 1% (45 cc. per gallon)
 Lissapol NDB, 2% (90 cc. per gallon)

FUEL SYSTEM

APPROVED FUELS	See leaflet T.S.D. 3085 in rear cover pocket
RELIEF VALVE SETTING	20 to 30 lbf./sq. inch (140 to 210 kN/sq.m.)
INJECTION PRESSURE	220 ats (22 000 kN/sq.m.)
FEED PUMP	Bosch FP/KD
INJECTION PUMP	Bosch-PE6P
GOVERNOR	Bosch-PA386R or Ambac
INJECTORS	CAV long-stem, multi-hole Holder (all engines): BKBL 96S 5348 Nozzle (N/A engines): BDLL 150S 6690 (T/C engines): BDLL 150S 6691
FILTER	Spin-on, expendable single canister

LUBRICATION SYSTEM

RECOMMENDED LUBRICATING OIL	See leaflet T.S.D. 3085 in rear cover pocket
SYSTEM TYPE	Wet sump, with spur gear pressure pump
*SYSTEM CAPACITY FOR OIL CHANGE	6.5 Imp. gallons (29.5 litres) or 5.5 Imp. gallons (25 litres)
OIL PRESSURE (At working conditions)	
Normal.....	50 to 70 lbf./sq. inch (350 to 480 kN/sq.m.)
Minimum for continuous operation (to protect turbocharger).....	30 lbf./sq. inch (206 kN/sq.m.)
FILTERS	Full flow, twin bowl, expendable elements
OIL-TO-COOLANT HEAT EXCHANGER	Serck

*Depending on the type of sump fitted. (See Section 11)

INDUCTION SYSTEM

AIR CLEANER	Donaldson 'Cyclopac' FHG 14
AIR RESTRICTION INDICATOR	Donaldson, 25 inches w.g.
TURBOCHARGER	Holset 4LGK
CHARGE COOLER	Serck or Coventry Radiators, air to air, integral with coolant radiator

Printed in Great Britain

ELECTRICAL SYSTEM

ALTERNATOR.....C.A.V. AC5B, 24 volt, 31 amp
or AC5R

CONTROL BOARD.....C.A.V. Type 440

STARTER MOTOR.....C.A.V. SP6A or S130L

STOP CONTROL.....C.A.V. solenoid operated, Type 368

SHUTDOWN SWITCHES

Oil pressure.....Drayton, Type EP
or Teddington-Type DCA/BC/152
22 lbf/sq. inch (152 kN/sq.m.) setting

Coolant temperature.....Drayton, Type ET
or Teddington-Type DCA/AB/096
96 deg. C. setting

AUXILIARY EQUIPMENT

COLD STARTING AIDS.....'Start Pilot' or 'Fleetguard'

**RECOMMENDED PROPRIETARY PRODUCTS FOR USE
DURING SERVICING AND OVERHAUL**

(Equivalents of alternative manufacture are acceptable)

	Manufacturer	Brand or specifications
ALTERNATOR		
Diode cleaning fluid	Applied Chemicals Ltd. Uxbridge, Middlesex	Fluid, Grade 8-23
COOLING SYSTEM		
Hose and 'O' ring lubricant	Isaac Bentley & Co. Ltd. Naylor St., Liverpool	Linalube
Pump bearing grease	Shell	Retinax 'A'
Thermostat spindle grease	Midland Silicones Ltd. Temple Row, Birmingham 2	Valve Seal 'A'
EXHAUST SYSTEM		
Screw thread anti-seize compound	Rocol Ltd. Swillington, Leeds	Rocol J 166
JOINTS		
Jointing compound (general use)	Wellworthy Ltd. Lymington, Hants	Wellseal
Sealant and thread locking, where specified	Douglas Kane Sealants Welwyn, Herts	Loctite 270, 241, 225
STARTER MOTOR		
Drive end bearing oil SP6A	Various	Mineral, SAE 10W/30W
Clutch assembly grease SP6A	Shell	Nerita
End shield bush (S130L)	Shell	Turbo 41 oil
Cleaning fluid	I.C.I. Limited	Genklene 'N'

Printed in Great Britain

TORQUE LOADINGS

These torque loadings apply to oil-wetted threads on R-H build engines, subject to the following conditions:

1. It must NOT be assumed that application of the specified torque is, in itself, sufficient to ensure that the components concerned are adequately secured together. The recommended method of assembling and, where applicable, the tightening sequence as given in this manual must also be observed.
2. Where the bolt or nut is locked by a tabwasher, lockplate or splitpin, the specified torque may be exceeded, if necessary, by the MINIMUM amount required to reach a locking position.

	TORQUE	
	lbf. ft.	Nm
ALTERNATOR PULLEY NUT		
C.A.V. AC5 alternator	40	55
CAMSHAFT		
Drivegear setbolts	45	60
Thrustplate setbolts	40	55
CONNECTING RODS		
Big end setbolts and nuts	160	220
CRANKSHAFT HUB RETAINING NUT*		
*If no torque wrench is available, use spanner GA.736 as described in E.S.I. 22	700	950
CRANKSHAFT DAMPER RETAINING SETBOLTS		
	30	40
CYLINDER HEADS		
Setbolts in black circles in illustration below	175	240
Setbolts and nut in white circles in illustration below	150	205
Rocker pedestal setbolts	30	40
Tappet screw locknuts	30	40
Injector flange nuts	8.5	11

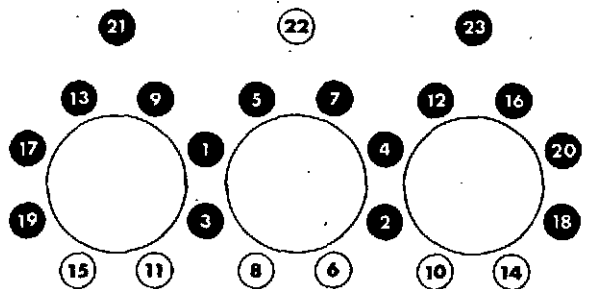

15468B

FLYWHEEL RETAINING SETBOLTS	85 to 90	115 to 120
FLYWHEEL HOUSING, BOLTS TO CRANKCASE	45	60
INJECTION PUMP		
Camshaft hub nut	85 to 90	115 to 120
Pump-to-mounting bolts	30	40
Spring drive bolts	85	115
INJECTOR NOZZLE CAPNUT	50	70
LUBRICATING OIL FILTERS		
Centre bolts, retaining bowls to header	20	27
LUBRICATING OIL PUMP DRIVEGEAR RETAINING NUT	50	70
MAIN BEARINGS		
Front, centre and rear bearing nuts*	160	220
Intermediate bearing nuts	200	270
Lateral setbolts	70	95
*On external capnuts at front and rear use extension spanner GA.21 at 140 lbf. ft. (190 Nm)		
SUMP		
Insert for drain plug	225 to 250	305 to 340
Drain plug insert	80 to 85	110 to 115
TURBOCHARGER 'V' BAND NUT	10	14



SECTION 2—DISMANTLING THE ENGINE

Printed in Great Britain

The engine will stand upon its sump, with suitable wood packing for levelling and stability, or alternatively may be fitted with simple feet of angle section, bolted to the four mounting faces. In this position, most of the external components may be removed, but for complete dismantling a turnover stand is desirable.

Before dismantling, clean the engine thoroughly and ensure that the coolant and lubricating oil systems are completely drained. Coolant drain taps are fitted at the rear of the crankcase on the left-hand side and, on some engines, at the rear of the heat exchanger. To open the taps, turn them anti-clockwise. The sump is drained by removing a wire-locked hexagonal plug at the base of the pannier.

Where dismantling involves removal of a proprietary item (e.g. turbocharger), or a sub-assembly (e.g. cylinder head), instructions for reducing these units to their component parts and subsequent re-assembly are given in their appropriate Sections.

Because these engines are built to suit individual installations, certain components may be mounted in different positions and therefore the dismantling sequence will vary slightly between models. The following sequence is for guidance, additional information being given when the work is other than simple and straightforward.

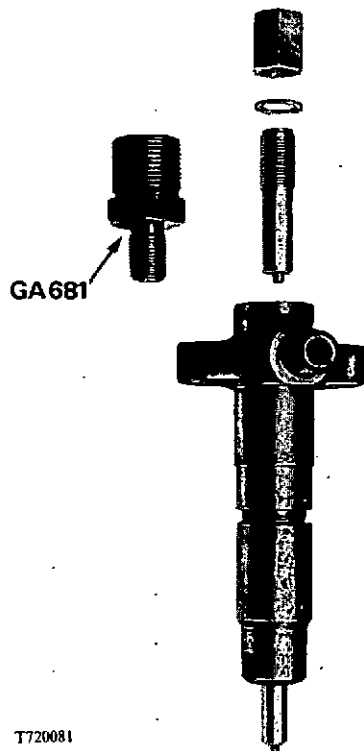

T720081

Fig. 1 Injector—exploded view



T720085

Fig. 2 Using extractor GA 627

DISMANTLING SEQUENCE

1. Turbocharger, taking care not to damage its oil feed and drain pipes.
2. Inlet manifold, after disconnecting boost control pipe and cold start aid, if applicable.
3. Starter motor.
4. Oil pressure relief valve casting from sump.
5. Heat exchanger and oil filters. Remove coolant pipes and unscrew the four setbolts which secure the assembly to its mounting plate.
6. Heat exchanger mounting plate.
7. Cooling fan.
8. Coolant rail and thermostat housing.
9. Exhaust manifold, after removing the fuel filter element.
10. Alternator and fan belts. Release tension of belts before removing them; do not lever belts away from pulleys.
11. Fuel filter header bracket.
12. Fuel supply, spill and injection pipes. Treat high-pressure pipes with special care. Blank off all connections immediately.
13. Injection pump and its mounting bracket.

Sling the engine by the eyes at front and rear, and install it in a turnover stand.

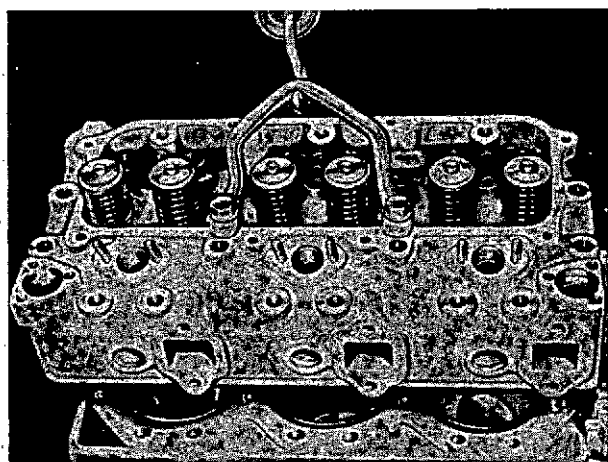

Fig. 3 Lifting cylinder head

T51124A

14. Rocker covers, valve gear and pushrods. Unlock and fully slacken the tappet adjusting screws before slackening the rocker pedestal setbolts.
15. Injectors. A sticking injector may usually be freed by gentle leverage beneath the flange, using tool GA.454. In obstinate cases, remove the injector capnut and adjusting screw (fig. 1), fit adaptor GA.681 and use the sliding weight extractor GA.627 (fig. 2).

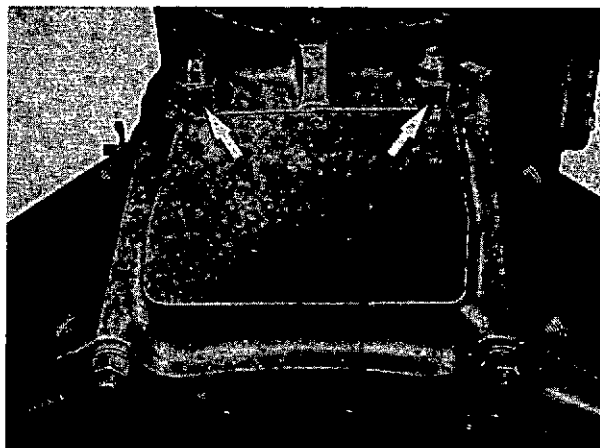

Fig. 4 Rear main bearing capnuts (front identical)

T720031

16. Cylinder heads. Slacken the setbolts and capnuts in tightening sequence (see Section 3). Using slinging attachment GA.13, lift off each head (fig. 3) taking care not to damage the oilway stud. Remove the coolant transfer bobbins, cylinder head joints and their rollpins, and oilway studs.
17. Tappet cover, oil gallery and cam followers.
18. Invert the engine, remove the sump bolts and lift off the sump. To break a sticking sump joint, use jacking bolts in the $\frac{3}{8}$ -inch UNF tappings at each corner. Unlock and slacken the oil pump drive-gear nut. Unbolt and remove the oil gallery and pump. Retain the shims fitted between pump and bearing cap.

19. Barring adaptor, damper and hub from crankshaft nose end. Adaptor and damper are secured by sixteen setbolts. Use spanner GA736 and a 4lb. (1.8kg.) hammer to slacken the hub nut (right-hand thread).
20. Wheelcase cover and gears. Unlock and slacken cam gear setbolts before removing idler gear.
21. Wheelcase backplate. Note positions of fitted bolts and dowels (see Section 12).
22. Clutch, flywheel and flywheel housing. After removing the flywheel setbolts, fit two guide bars GA.256 horizontally opposite to one another. (Do not use guide bars GA.687, which are for fitting the flywheel, or their nylon inserts may be damaged). Remove the timing pointer cover from the 4 o'clock position on the flywheel housing and unscrew the timing pointer, which otherwise will foul the starter ring. Using extractor GA.247, withdraw the flywheel dowels. Slide the flywheel clear of its housing, fit slinging eye GA.16 to a circumferential bolt-hole, and lift the flywheel away.
23. Crankshaft rear seal. Note four locating dowels (two in crankcase, two between seal halves).
24. Turn engine horizontal. Remove big-end bolts, caps and bearings, and carefully withdraw pistons and connecting rods through the cylinder bores. Keep each assembly together.
25. Using extension spanner GA.21, slacken external capnuts of front and rear main bearings (figs. 4 and 5).
26. Invert engine. Slacken and remove main bearing lateral setbolts on both sides of crankcase (fig. 6).
27. Remove main bearing nuts, including external capnuts (fig. 4).
28. Extract main bearing caps, using tool GA.2/M1 (fig. 7) where necessary.
29. Using slinging beam J.47789, lift out the crankshaft (fig. 8).
30. Turn engine vertical and extract cylinder liners, using tool GA.629 (fig. 9). Protect liners against damage whilst out of crankcase.
31. Camshaft. Take care not to damage bearing surfaces during withdrawal. Extract rear bearing sealing plug by means of two $\frac{5}{16}$ inch UNF bolts screwed into the tappings provided.

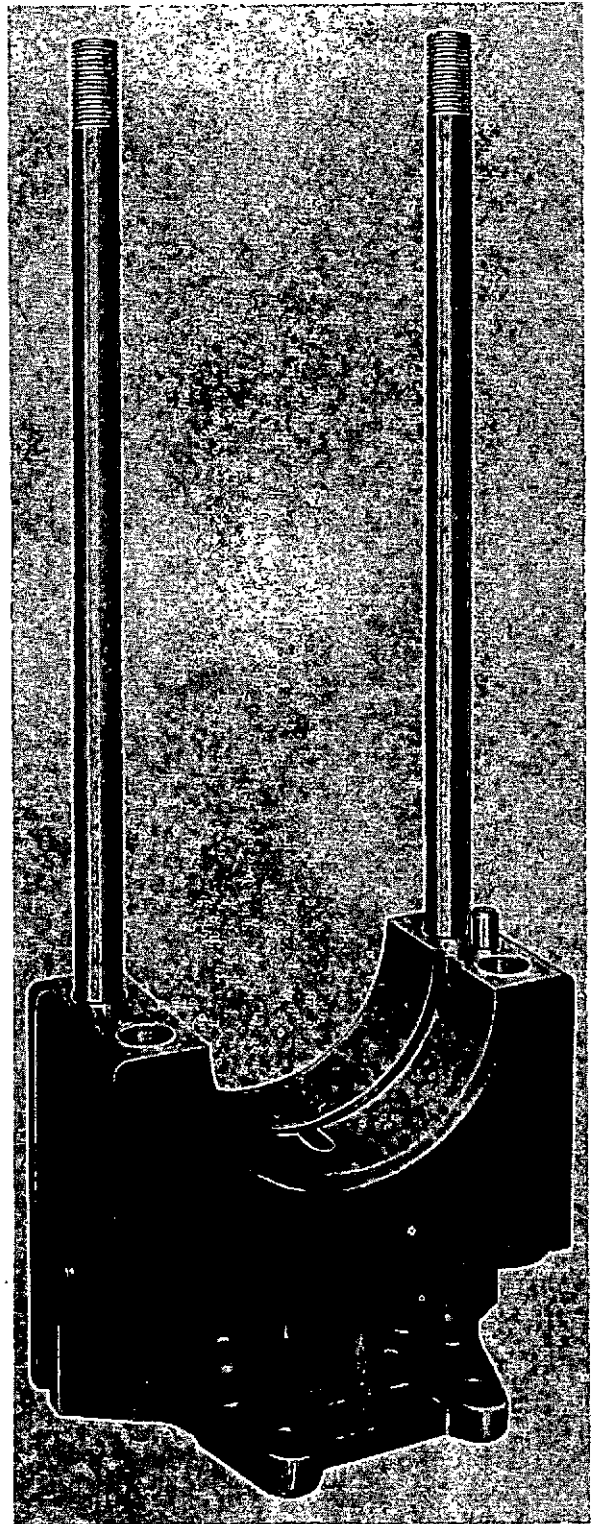

Fig. 5 Front and rear main bearing caps

T720032

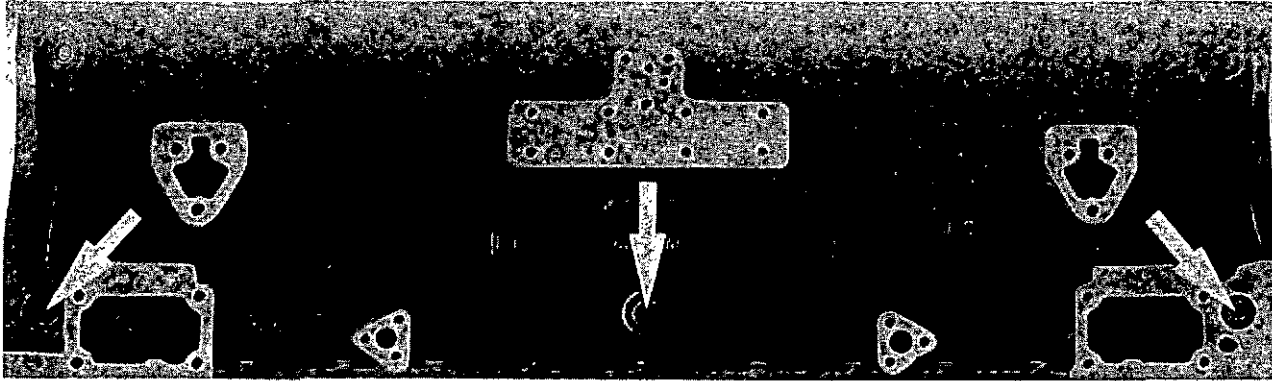

Fig. 6 Main bearing lateral bolts, both sides of crankcase

T720033

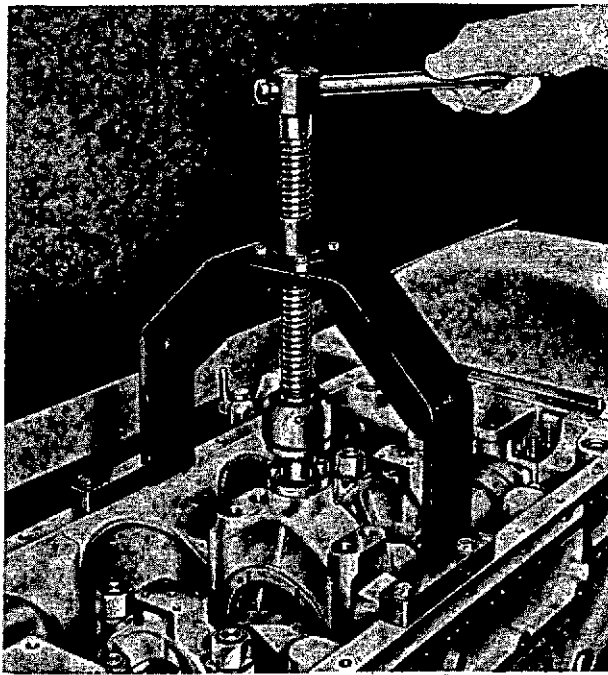

Fig. 7 Extracting main bearing cap

T195

SPECIAL TOOLS

- J.47967 Engine turnover stand
- J.47783 Crankcase lifting tackle
- GA.454 Injector extractor, lever type
- GA.627 Injector extractor, inertia type
- GA.681 Adaptor, GA.627 to injector
- GA.13 Lifting attachment, cylinder head
- GA736 Spanner, crankshaft hub nut
- GA.256 Guide bars, flywheel removal
- GA.247 Extractor, flywheel dowels
- GA.16 Slings eye, flywheel
- GA.21 Extension spanner, main bearing capnuts
- GA.2/M1 Extractor and inserter, main bearing caps
- GA.629 Extractor and inserter, cylinder liners
- J.47789 Slings beam, crankshaft

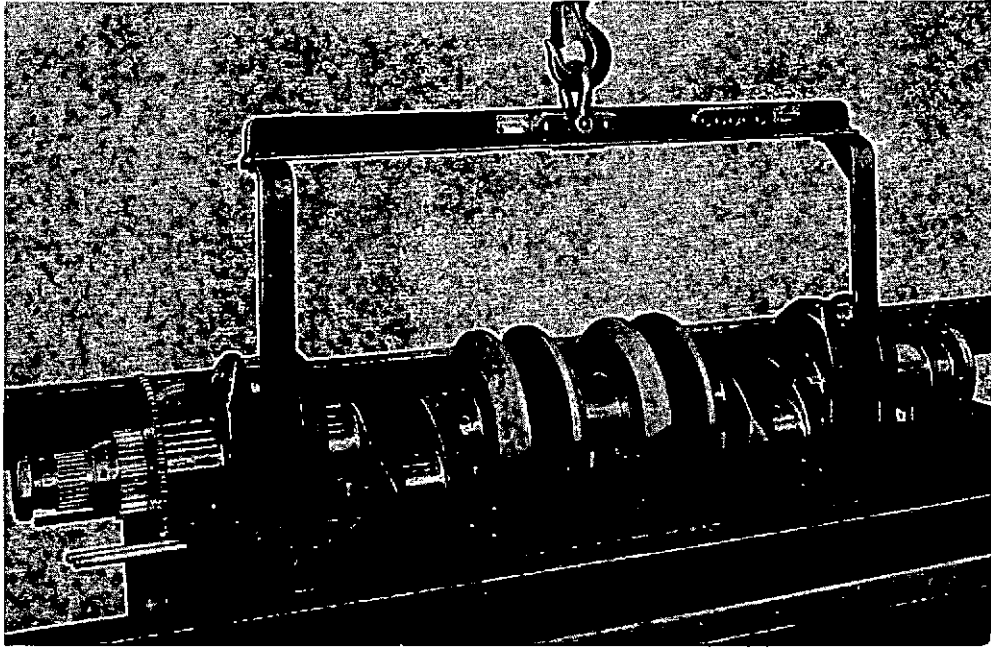

Fig. 8 Lifting crankshaft

T720034

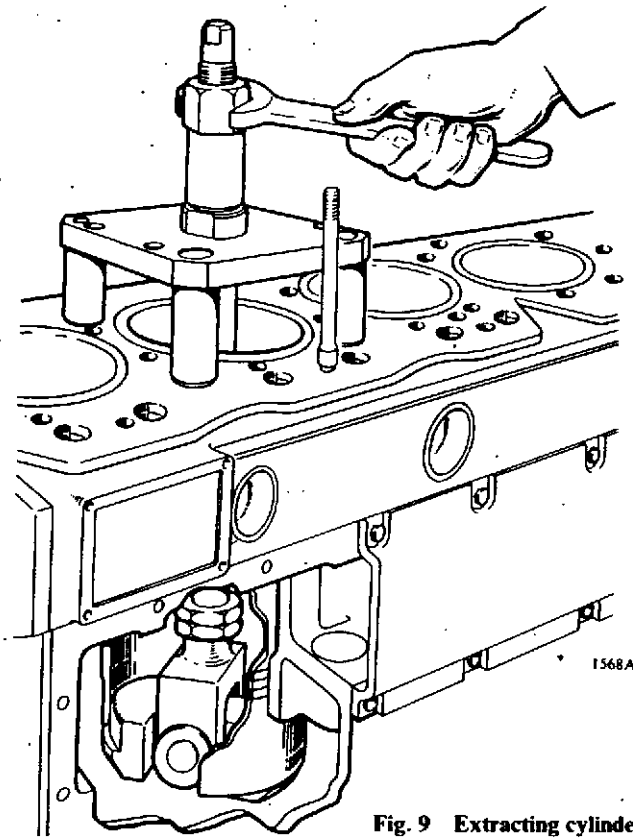

Fig. 9 Extracting cylinder liner



SECTION 3—ASSEMBLING THE ENGINE

This Section deals with final erection of the engine from components which have been inspected, (and, where applicable, built into sub-assemblies) as described under their appropriate headings.

Attention is drawn to the recommendations made under 'General Information' at the front of this Manual. These are based on good engineering practice and their observance is essential to the production of an efficient, reliable and long-lived unit.

SEQUENCE OF ASSEMBLING

A typical sequence is summarised below and followed by a detailed description of each operation in the same order. As with dismantling, the positioning of certain components (e.g. Turbocharger) to suit an installation may affect the sequence slightly, but this will only occur after the basic engine has been assembled.

- 1-2. Preparing crankcase
3. Cylinder liners to crankcase
4. Crankshaft and main bearings
5. Camshaft to crankcase
6. Wheelcase backplate
7. Camshaft front end
8. Backlash checks
9. Timing wheelcase gears
10. Oilway studs
11. Cam followers, and oil gallery to valve gear
- 12-13. Connecting rods and pistons, as units
14. Cylinder heads and valve gear

15. Adjusting tappet clearances
16. Oil pump and gallery
17. Oil pressure test
18. Crankshaft rear seal
19. Flywheel housing
20. Flywheel
21. Wheelcase cover
22. Sump
23. Crankshaft front end
24. Manifolds and coolant rail
25. Coolant pump
26. Heat exchanger
27. Starter motor
28. Oil filters
29. Fuel filter
30. Injection pump and mounting bracket
31. Injectors
32. Injection and spill pipes
33. Alternator and belts
34. Turbocharger
35. Miscellaneous

METHOD OF ASSEMBLING

1. **Crankcase in turnover stand.** When the core plugs have been fitted, mount the crankcase in the stand using four temporary bearer brackets.
2. **Camshaft rear bearing sealing plug.** Use a new 'O' ring, enter the plug with its tapped holes outwards, and press it flush with the crankcase rear face.

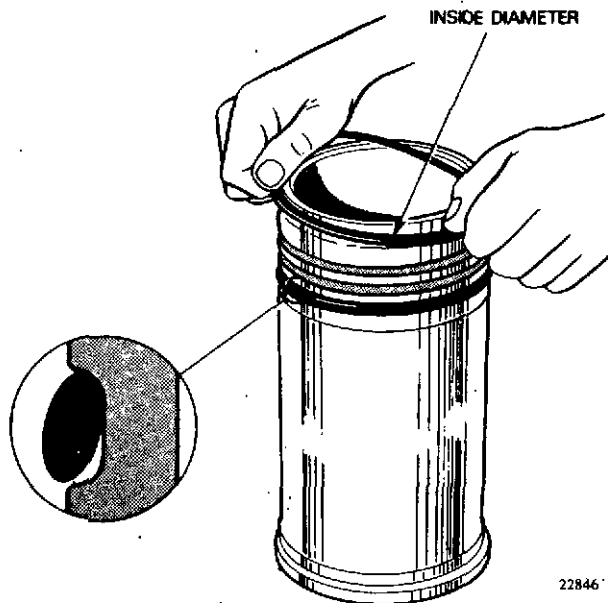

Fig. 1 Fitting liner sealing rings

22846

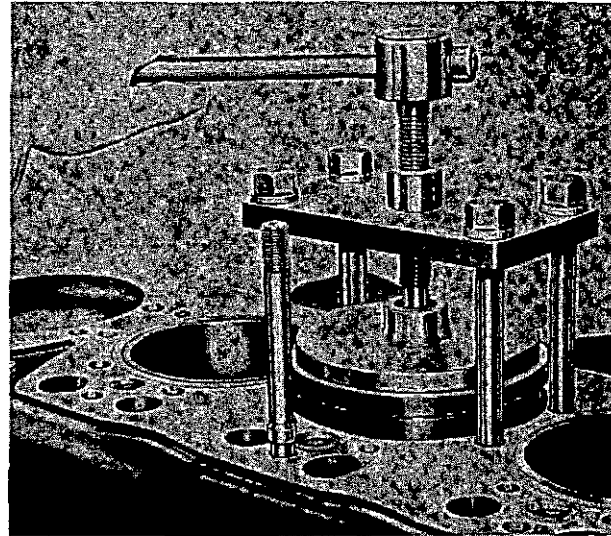

Fig. 2 Pressing in cylinder liner

T51127

3. **Cylinder liners.** See Section 4 for reconditioning and protrusion checks, noting that a replacement liner must be etched with its position number, as described below, when its protrusion check is completed.

On each liner in turn, apply Linalube — Part No. OE. 45113 (NOT grease) to the skirt and fit new sealing rings as illustrated in fig. 1, ensuring that each ring takes up the position shown and is not twisted. An improved ring OE. 46017, having a blue-and-white paint marking, is now in use. Apply 'Linalube' to the crankcase in the skirt area and insert the liner into its correct numerical position (numbering is from front to rear), aligning the position number etched on the spigot to the large coolant port (fig. 14). Use tool GA. 629 to press the liner fully home (fig. 2). Do NOT drive the liner in, or damage may result.

INVERT THE ENGINE

4. Crankshaft and main bearings

- (a) Check that dowels are in position at front, centre and rear bearing housings. Fit and oil the upper halves of the bearing shells. Sling the crankshaft, complete with its gears and

sealing plugs (see Section 6) and lower it into position. Feed the upper halves of the thrust washers into place on both sides of the centre bearing, with the bronze face of each washer to the crankweb (fig. 3). Assemble the lower half bearing shell and the lower halves of the thrust washers to the centre bearing cap, and fit the cap. Fit the remaining bearing caps and lower half bearings.

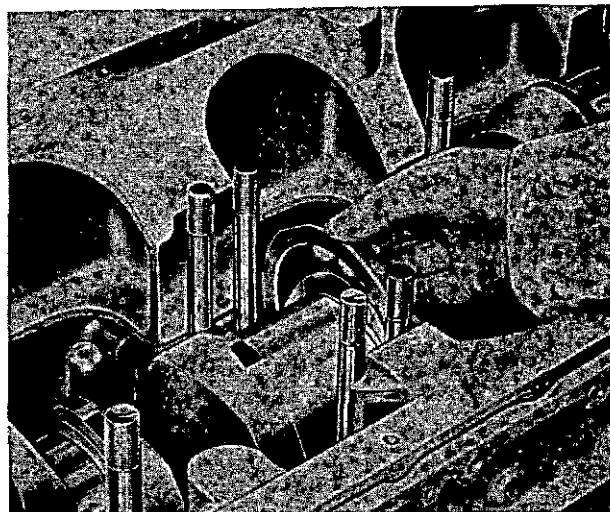

Fig. 3 Fitting upper half thrust washer

T202

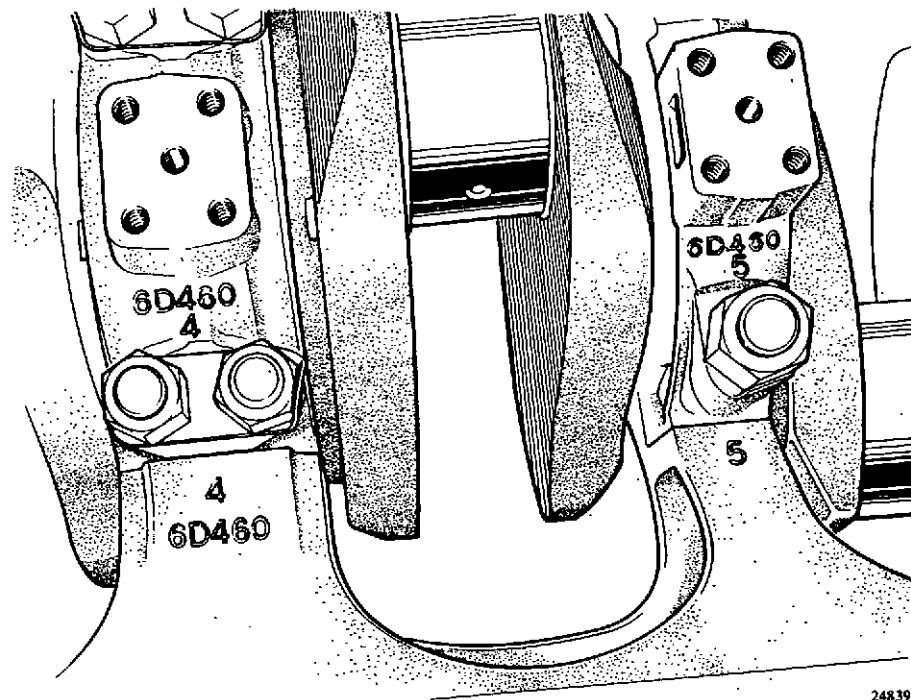

Fig. 4 Main bearing correlation marks

Notes: (i) The correlation marks on each bearing cap must correspond to the adjacent marks on the crankcase (fig. 4).

(ii) Before fitting the front and rear main bearing caps, check that the oilway blanking plug in each has been fitted, using Loctite '225' and locked by its tabwasher.

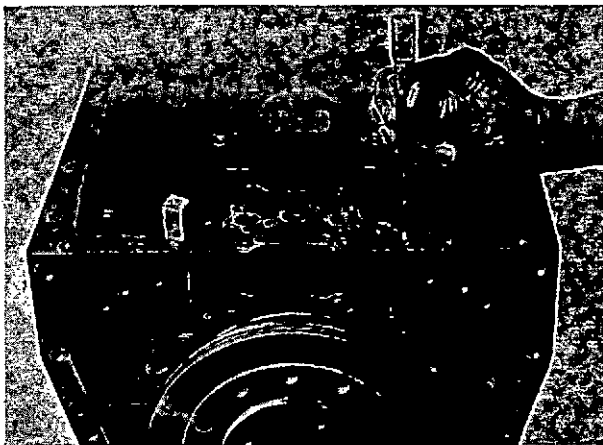

Fig. 5 Rear main bearing sealing plugs

T720035

Oil the threads of the main bearing studs, and fit the lockplates and nuts, applying a light smear of molybdenum disulphide grease to each nut on the face in contact with the lockplate. Fit also the external capnuts at front and rear. Do not tighten any bearing nuts beyond nipping point at this stage.

(b) Fit and nip the lateral setbolts, each with a plain washer beneath the head, at Nos. 1, 4 and 7 bearing positions on both sides of the crankcase.

(c) Working outwards from the centre, progressively tighten the main bearing nuts to the following torque loadings:

- Centre and both end bearings —
160 lbf.ft. (220 Nm)
- Intermediate bearings —
200 lbf.ft. (270 Nm)

Note: When tightening the external capnuts, the extension spanner GA.21 and a torque loading of 140 lbf.ft. (190 Nm) gives an effective loading of 160 lbf.ft. (220 Nm).

(d) Tighten the lateral setbolts to 70 lbf.ft. (95 Nm).

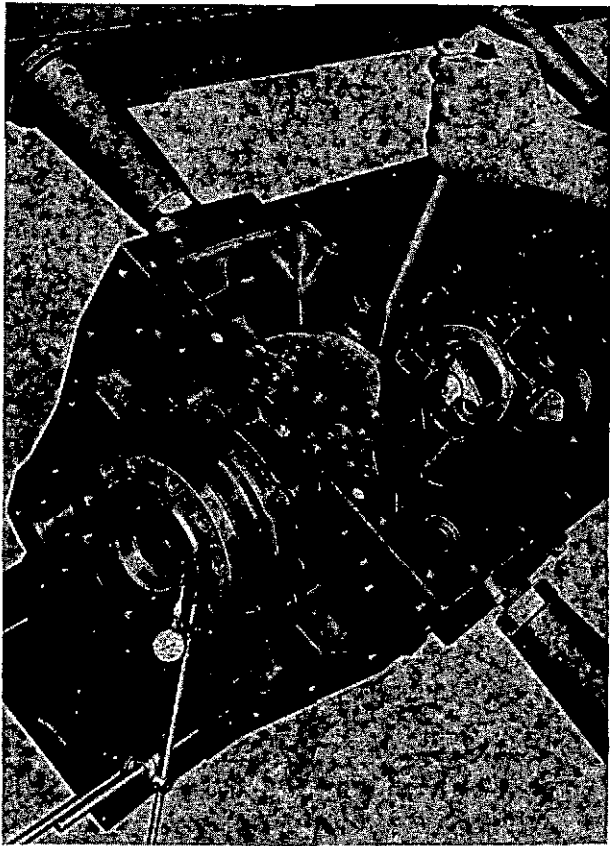

Fig. 6 Measuring crankshaft end float

T720036

- (e) Fit wooden sealing plugs to the rear main bearing cap. Coat each plug with 'Wellseal', drive it fully home (fig. 5), and cut off the surplus flush with the crankcase.
- (f) Check that the crankshaft rotates freely, and measure its end float (fig. 6). Limits are 0.005 to 0.013 inch (0.13 to 0.33 mm).

TURN THE ENGINE UPRIGHT

5. **Camshaft.** Check that the plugs are fitted to each end of the shaft (screwed plug, locked by tab-washer, at rear; aluminium plug and 'O' ring, extractor tapping outward, at front). Oil the bearing surfaces and carefully guide the shaft into position in the crankcase.
6. **Wheelcase backplate.** Fit the two locating dowels (see fig. 10), apply a thin coat of 'Wellseal' to the crankcase front face and attach the joint. Apply 'Wellseal' to the joint and fit the backplate, using temporary bolts and nuts with distance pieces as illustrated to ensure rigidity. Fit the idler gear axle, located by two dowels with circlips, tighten its setbolts and bend up their tabwashers. Refer to Section 12 if a new backplate or axle are to be fitted.
7. **Camshaft front assembly.** Referring to fig. 7, fit the thrust plate, counterbore inwards, centralise it visually around the camshaft, tighten its setbolts to 40 lb.ft. (55Nm) and bend up their

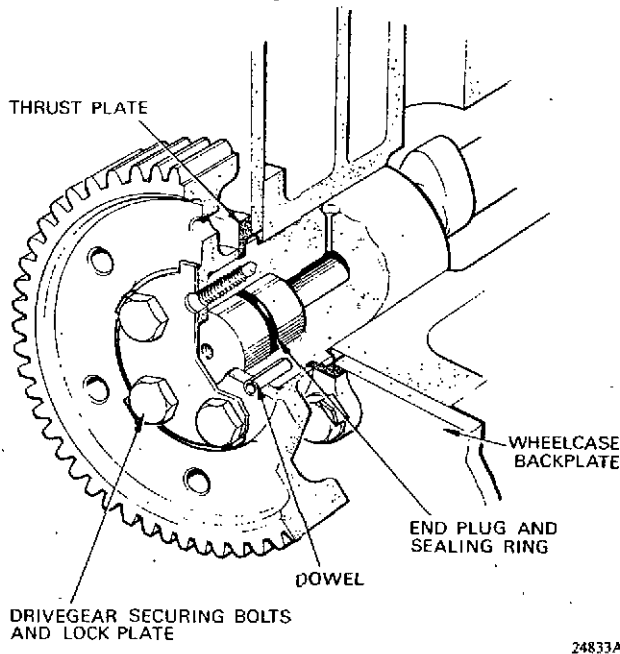

Fig. 7 Camshaft front end assembly

24833A

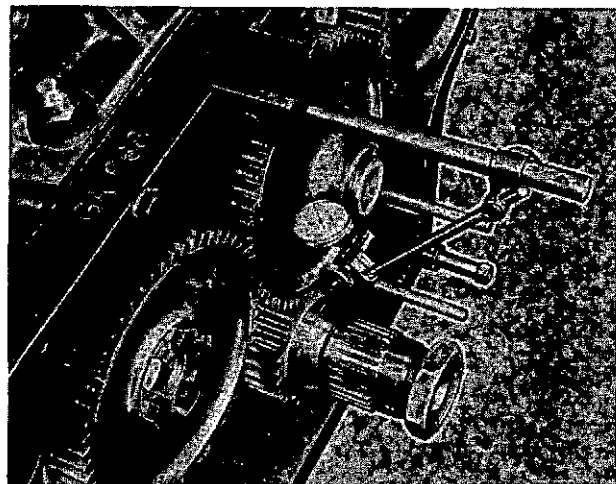
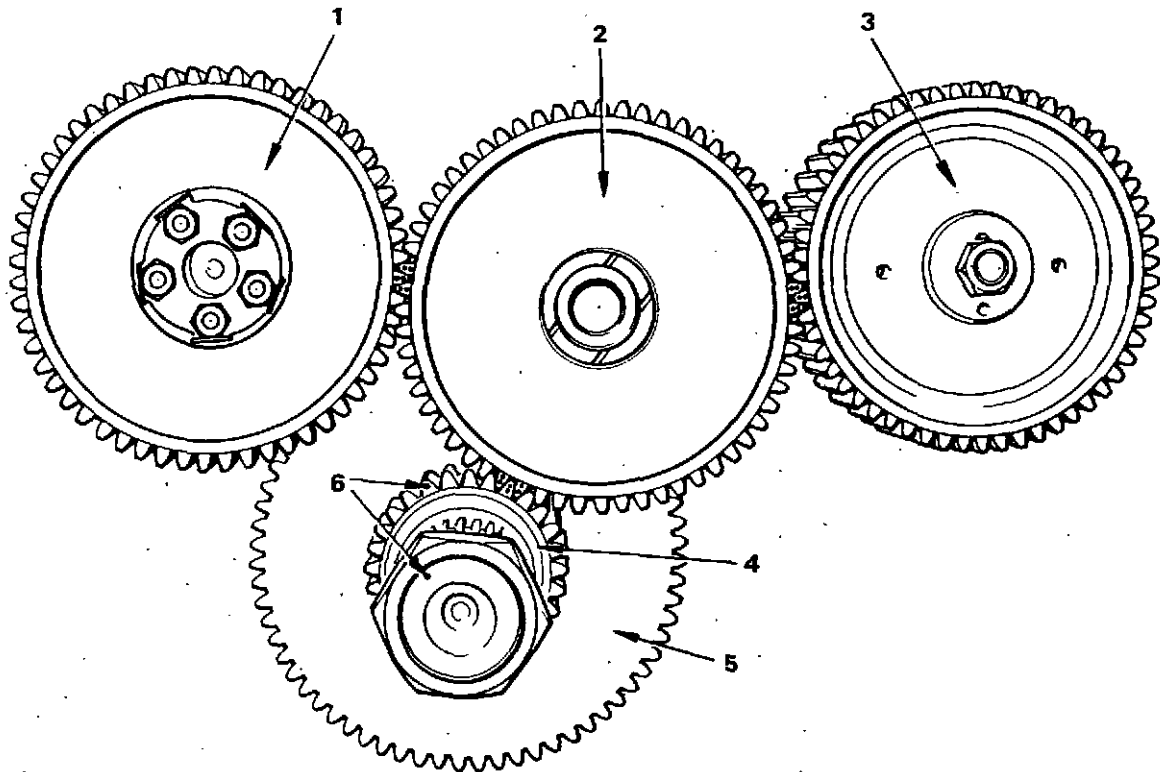

Fig. 8 Measuring idler gear backlash

T720037



- | | |
|-----------------------|------------------------------------|
| 1 CAMSHAFT DRIVEGEAR | 4 CRANKSHAFT PINION |
| 2 IDLER GEAR | 5 OIL PUMP DRIVEGEAR |
| 3 AUXILIARY DRIVEGEAR | 6 CRANKSHAFT PINION LOCATION MARKS |

Fig. 9 Timing marks, wheelcase gears

24834

tabwashers. Assemble the drivegear on its five rollpin dowels, which are offset for correct location, and fit the setbolts and lockplate. Temporarily fit the idler gear to prevent rotation, and tighten the setbolts to 45 lbf.ft. (60Nm), Check that the camshaft end float is within the limits of 0.004 to 0.010 inch (0.10 to 0.25mm), and bend up the tabs of the lockplate.

8. **Backlash checks.** Bolt the stiffening frame GA.668 to the wheelcase backplate. Measure the backlash, in each instance at four equidistant points on the idler gear circumference, between the idler gear and each of the three gears with which it meshes (fig. 8). For all these gears, limits

are 0.004 to 0.010 inch (0.10 to 0.25mm): If incorrect backlash cannot be rectified by renewal of worn gears, the idler gear axle must be repositioned as described in Section 12. Remove the stiffening frame GA.668 on satisfactory completion of checks.

9. **Timing of wheelcase gears.** Mesh the idler with the crankshaft pinion, camshaft drivegear and auxiliary drivegear so that the marked teeth are engaged as shown in fig. 9.

10. **Oilway studs.** Ensure that the drillings (arrowed, fig. 11) are clear, and fit the two studs to the crankcase top face.

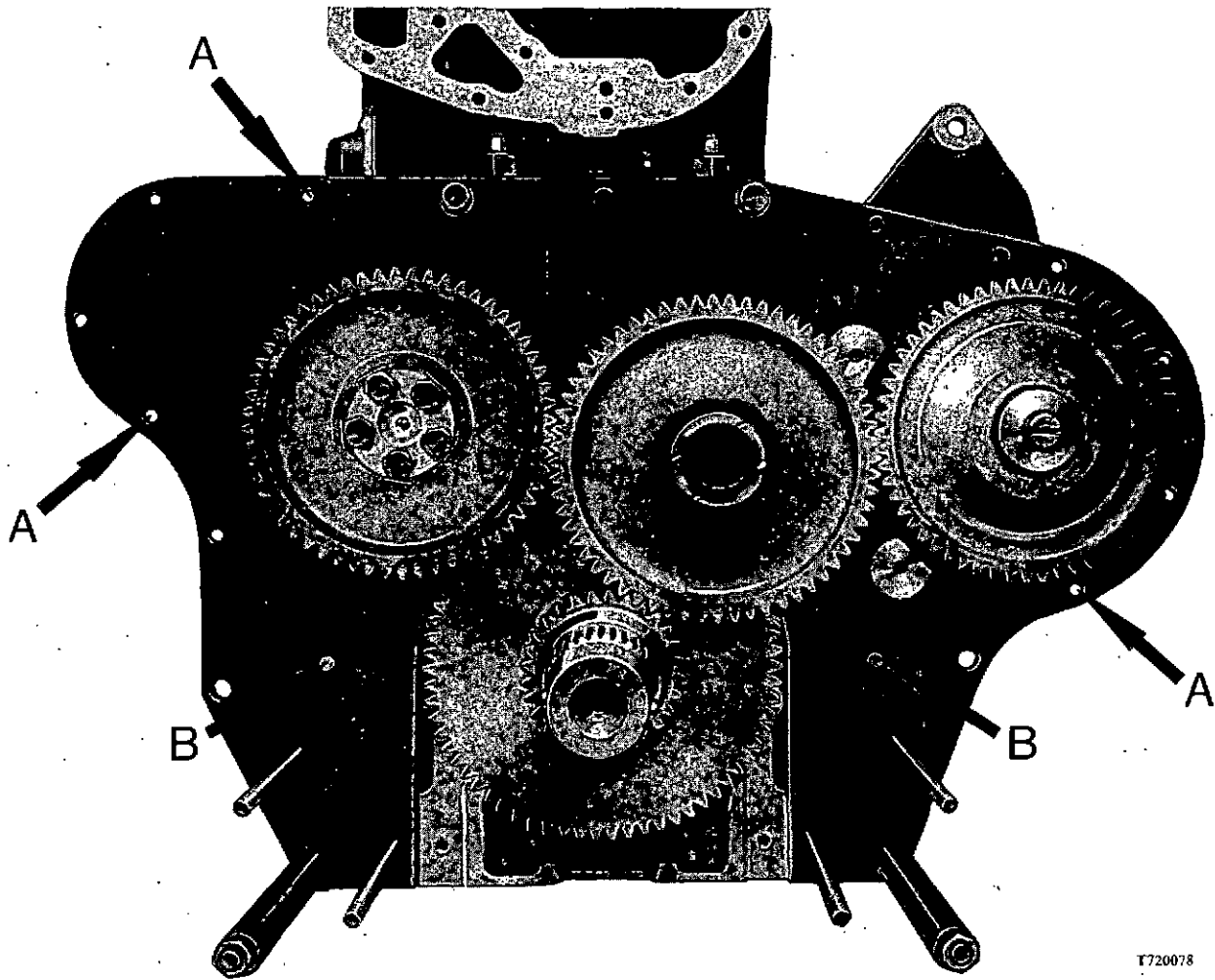

T720078

A FITTED BOLTS—WHEELCASE LOCATION
B DOWELS—BACKPLATE LOCATION

Fig. 10 Wheelcase and backplate location points

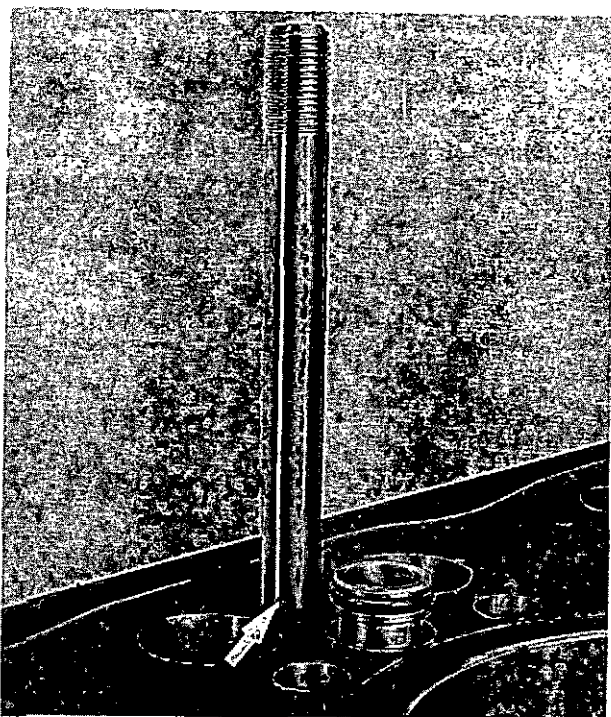

Fig. 11 Cylinder head oilway stud (drilling arrowed) T720039

11. **Cam followers and valve gear oil gallery.** Oil and fit cam followers. Assemble the oil gallery with its longest face inwards (fig. 12) and a spigot washer beneath each bolt head. Fit the baffle plate, with a joint on each side, and the tappet cover. Fit two retaining tools GA.623 (fig. 12) to prevent the cam followers falling out if the engine is inverted prior to fitting cylinder heads.

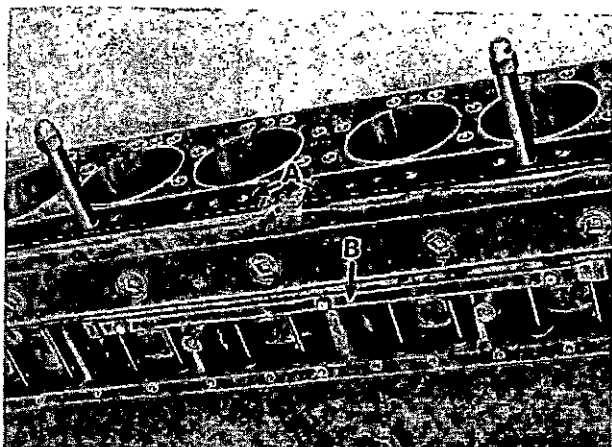

Fig. 12 Cam follower retainers (A) and oil gallery (B) T720040

TURN THE ENGINE HORIZONTAL

12. **Connecting rods and pistons.** With these components assembled together as described in Section 7, oil the pistons, stagger the ring gaps and, using tool GA.12 to compress the rings (fig. 13), enter each assembly into its liner, with the relative position of piston to crankcase as shown in fig. 14. Guide the connecting-rod towards the crankpin, oil the bearings, and assemble the big-ends with the correlation marks aligned. Fit the big-end bolts, oil their threads and tighten the nuts to 160 lbf.ft. (220 Nm) or alternatively until the bolts have stretched 0.008 to 0.011 inch (0.20 to 0.27 mm). No locking is necessary.

Note: On all 'C-RH' build engines the big-end bearings have a circumferential oil groove to supply oil to the piston-cooling jets in the small-end eye. These bearings are NOT interchangeable with ungrooved bearings used on earlier engines which did not have piston cooling jets.

13. **Checking piston height.** With each piston in turn at TDC, measure the clearance of the piston crown below the crankcase top face. A dial gauge kit GA.65 can be supplied to special order. Alternatively, use datum tool GA.693 (or a locally-produced tool made to the dimensions in fig. 15) in conjunction with feeler gauges. Clearance must be between 0.012 and 0.015 inch (0.30 and 0.38 mm) and if necessary this may be obtained by machining the piston top face. Restore the 'FRONT' and cylinder position markings if these are removed by this machining.

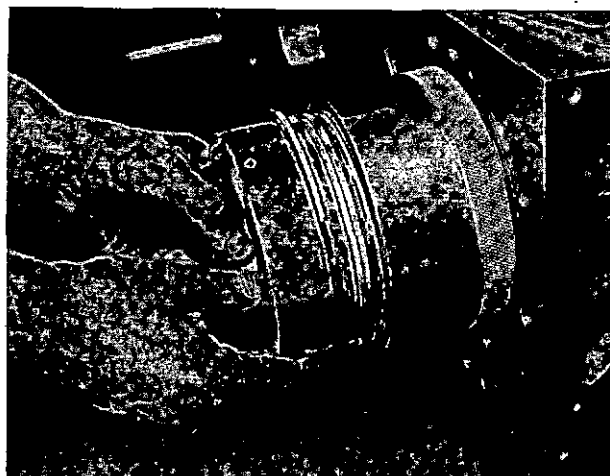

Fig. 13 Fitting piston and connecting rod T720041

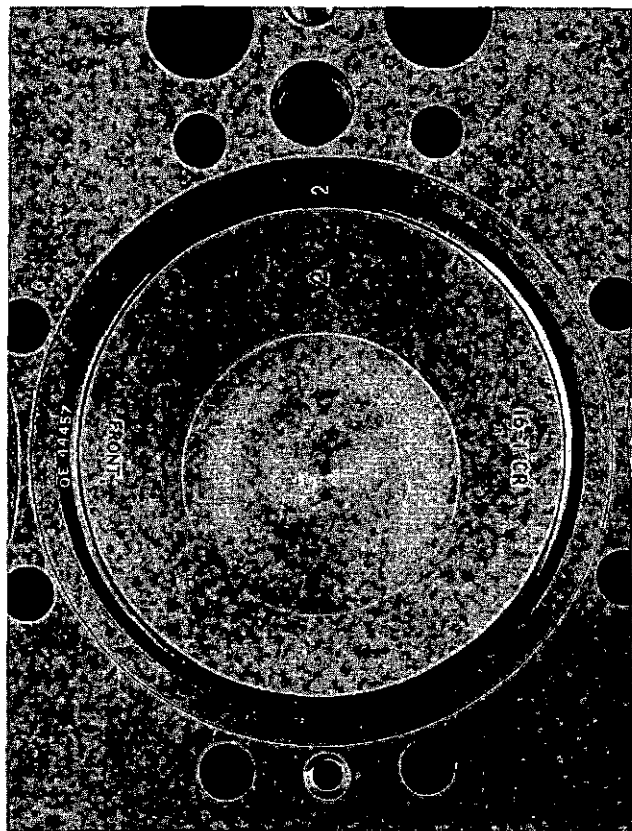

Fig. 14 Correlation of piston and liner to crankcase

T720042

14. **Cylinder heads and valve gear.** Fit the four rollpins which locate the cylinder head gaskets to the crankcase top face. Thoroughly clean all joint faces, but do not remove the anti-corrosive coating from the gaskets. Fit the large coolant bobbins and locate the gaskets, corrugations uppermost, on their dowels. Fit the small bobbins, screw in a guide bar opposite each oilway stud and lower the heads into position.

Assemble a hardened steel washer to each setbolt and oilway stud. Sparingly oil the threads and washers before fitting the bolts and nuts. Do NOT apply oil excessively, since it could enter the blind bolt holes and cause hydraulic pressures, and do NOT drop the bolts into their holes or the threads may be damaged.

Screw in each bolt at least two turns by hand to ensure correct engagement; similarly, fit the oilway stud nuts finger-tight. Gently nip all setbolts and nuts; then align the heads by temporarily fitting the inlet manifold, without joints and nipping its setbolts.

In the sequence shown in fig. 16, tighten down each cylinder head as follows:

- (a) All setbolts and nuts to 50 lbf.ft. (70 Nm).
- (b) All setbolts and nuts to 100 lbf.ft. (140 Nm).
- (c) All setbolts and nuts to 150 lbf.ft. (205 Nm).
- (d) In rising numerical order, all setbolts in black circles to 175 lbf.ft. (240 Nm).

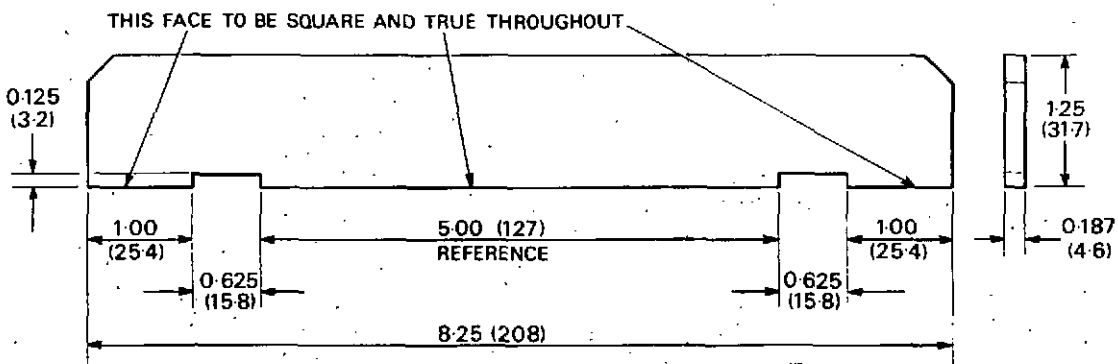

MATERIAL: MILD STEEL

DIMENSIONS: INCHES (MM)

24835

Fig. 15 Datum tool for checking piston height with feeler gauges

Note: The setbolts and nuts of a newly-fitted cylinder head must be re-torqued to their final loadings, and the tappet clearances checked, after the first 10 to 20 E.S.C. units. This work is to be carried out on complete engines after running-in at the factory.

Assemble the pushrods and valve rocker gear, with a plain steel washer beneath the head of each pedestal setbolt. Before tightening down, ensure that the tappet adjusting screws are slackened to the 'maximum clearance' position. Tighten the pedestal setbolts evenly to 30 lbf.ft. (40Nm).

15. **Adjusting tappet clearances.** To facilitate barring over the crankshaft, screw two setbolts into its rear face. Turn the crankshaft anti-clockwise, viewed from the rear, and adjust tappet clearances in the following cylinder sequence. The term 'valves rocking' means 'inlet valve just opening, exhaust valve just closing'.

Valves rocking on	Adjust tappets on
No. 6	No. 1
No. 3	No. 4
No. 5	No. 2
No. 1	No. 6
No. 4	No. 3
No. 2	No. 5

Adjust the valve tappet clearances as illustrated in fig. 17, to the following dimensions:

Inlet: 0.015 inch (0.38mm)
 Exhaust: 0.025 inch (0.63mm).

Re-check each clearance after tightening the locknut of the adjusting screw to 30 lbf.ft. (40 Nm). Do not fit the rocker covers permanently until

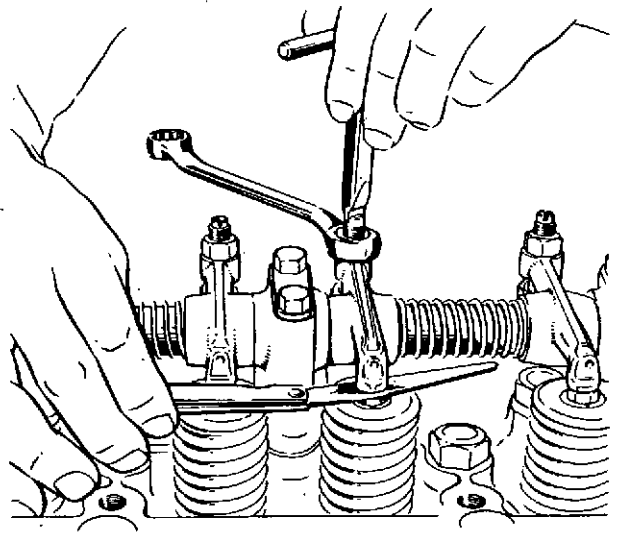

23375A

Fig. 17 Adjusting tappet clearance

the oil pressure test and injection pump timing have been carried out. Pour oil over the valve gear before finally fitting the covers.

INVERT THE ENGINE

16. **Oil pump and gallery.** These components are fitted separately, pump first. Drivegear backlash is adjusted by shims between pump casing and main bearing cap. The pump is located to the bearing cap by two dowels which pass through the shims.

Using the original shims, fit the dowels and bolt the pump to the bearing cap. Fit the drivegear, tighten its retaining nut to 50 lbf.ft. (70 Nm) and bend up the tabs of the lockwasher.

Check drivegear backlash at four equidistant points on the gear *with the engine upright in running position*. Limits are 0.002 to 0.006 inch (0.05 to 0.15mm). Adjust if necessary by varying the shim thickness between pump and bearing cap. Shims are supplied in thickness of 0.008 and 0.012 inch (0.2 and 0.3mm).

Note: If this backlash is measured with the engine *inverted* the reading on a new engine should be between 0.004 and 0.010 inch (0.10 and 0.25mm), due to the crankshaft moving to the opposite limit of its radial clearance in the main bearings.

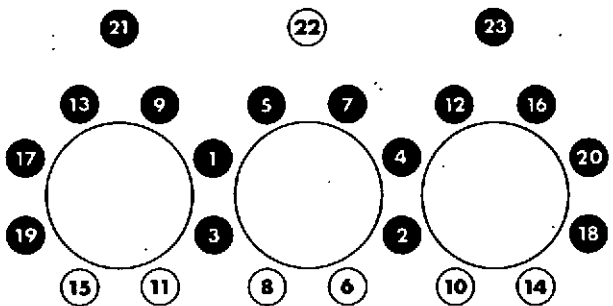

15468B

Fig. 16 Cylinder head tightening sequence

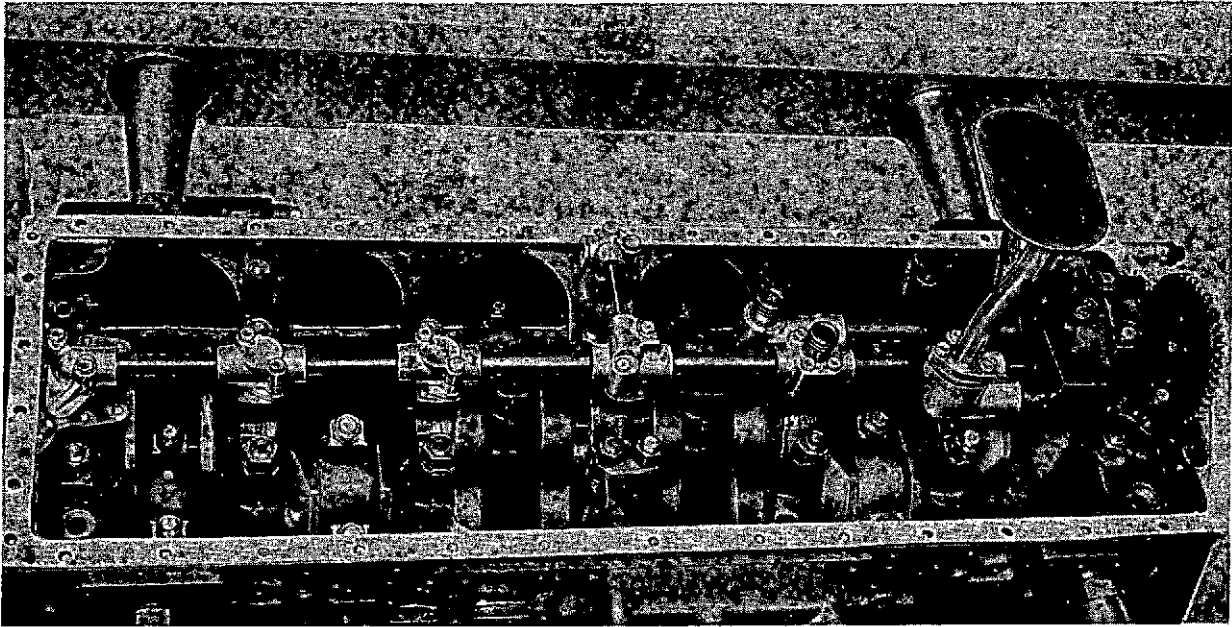

T720043

Fig. 18 Oil gallery, forward pannier sump

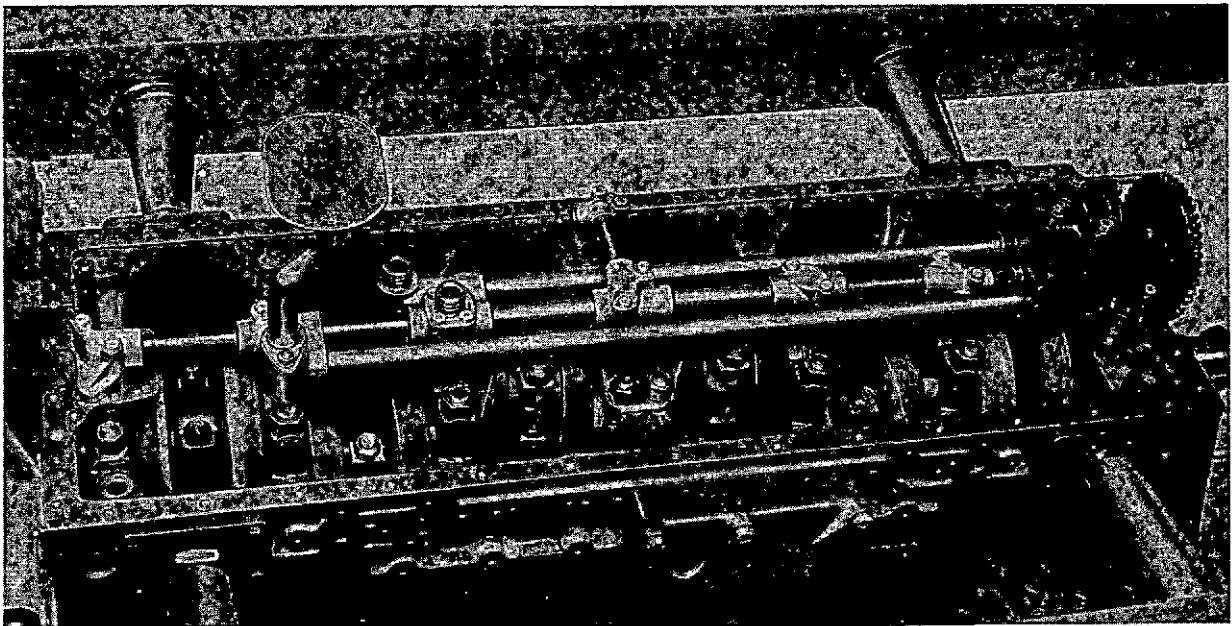

T720044

Fig. 19 Oil gallery, rear pannier sump

Fit new 'O' rings to the pump, assemble the gallery (figs. 18 and 19), also using new 'O' rings, and bolt it into position using a new joint washer at each bearing cap. Bend up all locking tabs and finally, screw the drain tube into its taper thread in the rear bearing cap.

17. **Oil pressure test.** This test requires a rig capable of supplying at least 2 gallons (9 litres) of filtered lubricating oil at 40 lbf./sq. inch (276 kN/sq.m).

Bolt a temporary retaining plate over the camshaft rear bearing plug. Fit sealing plug GA.45 to the bore of the idler gear axle (arrowed, fig. 20). With the engine inverted, connect the test rig to the gallery inlet (fig. 20) and admit oil at 40 lbf./sq. inch (276 kN/sq.m) to the system. Check that oil issues from the following points:

1. Oil pump bearings;
2. All main, big-end and small-end bearings;
3. Connecting rod small-end drillings for piston cooling;
4. Camshaft bearings;
5. Valve rocker gear;
6. Outlet connection, for injection pump supply.

Inspect crankpin sealing plugs and oil gallery joints for leakage. Shut off the oil pressure, remove sealing plug GA.45 from the idler gear axle, and check that oil is present in the axle bore. Pour about 1 pint (0.6 litre) of oil into the suction filter, turn the crankshaft in the direction of rotation and check that oil emerges from the outlet bobbin adjacent to the test rig connection.

Note: It is advisable to carry out the pressure test at this stage of engine build (i.e. before the rear main bearing seal is fitted) to avoid any possibility of oil accumulating in the seal due to the crankshaft being stationary. Such an accumulation could render the seal ineffective and possibly set up a siphoning action under running conditions.

18. **Crankshaft rear seal**

(a) *Engines fitted with rear-drop sump*

The seal arrangement consists of a two-piece housing which encloses an Acme thread and slinger ring machined on the crankshaft. The two halves of the housing are dowelled together, the assembly then being located to the crankcase by two dowels with retaining circlips (fig. 21).

To assemble the seal, fit the two dowels and the retaining circlips to the crankcase rear face,

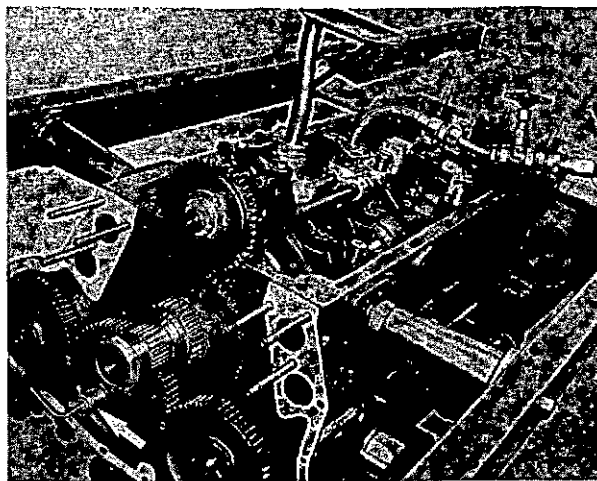

Fig. 20 Lubrication system pressure test

T720045

and affix a new joint washer with a thin smear of 'Wellseal'. Fit the upper half of the seal to the crankcase so that its two dowels are *just* entered. Fit the dowels between the seal halves, apply a thin coat of Loctite '225' to both joint faces of the halves, and bolt them together. Push the seal assembly fully home and bolt it to the crankcase.

(b) *Engines fitted with forward-drop sump.*

This type of seal arrangement consists of a lip type oil seal pressed into a single piece housing (fig. 22).

To assemble the seal arrangement to the engine, press the seal fully home in the housing and fit the two dowels with the retaining circlips into the respective holes on the rear of housing flange. Smear both sides of the joint washer with 'Wellseal' and affix over the dowels on the housing, ensuring that the cut-away on inside diameter of joint washer is in line with the drain trough in the housing. Fit the guide tool GA.800 to the crankshaft flange and wipe the edge of flange with clean dry rag. Slide the housing and seal over the guide tool with the drain trough positioned to the bottom of the crankcase. Press firmly into position on the dowels and secure with the fixing screws. Remove the guide tool GA.800.

CAUTION Care should be taken not to damage the lip seal during handling and fitment. A damaged seal should be discarded and a new seal

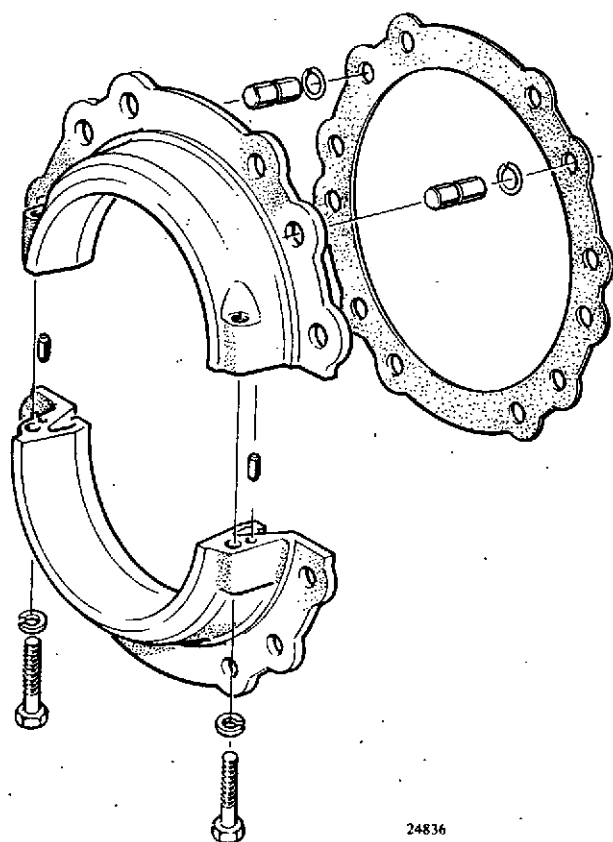

Fig. 21 Crankshaft rear seal—exploded

fitted. Failure to replace a damaged seal can result in oil leakage when the engine is returned to service.

19. **Flywheel housing.** Note: If a tachometer perception head is fitted, remove it until the flywheel is in position.

Ensure that the blanking setbolt and aluminium washer are fitted to the oil hole in the crankcase rear face, opposite the camshaft blanking plug. Mount the flywheel housing on its two dowels, fit the setbolts, tighten them to 45 lbf.ft. (60 Nm) and bend up their tabs.

When fitting the two external stiffening brackets, fully tighten them to the flywheel housing before tightening their remaining setbolts.

20. **Flywheel.** One of the three dowel holes is offset (fig. 25). Position this hole at 6 o'clock by setting the crankshaft to No. 1 TDC. Fit two nylon-

faced guide bars GA.687 to the crankshaft rear face. Unscrew the timing pointer. Offer up the flywheel with its timing marks at approximately 4 o'clock, thus aligning the dowel holes, and push it into place along the guide bars. Temporarily secure the flywheel by two setbolts at opposite points, nipped up and then slackened slightly. Grease the three dowels sparingly and fit each one by tapping on the head of a $\frac{1}{16}$ inch UNF bolt temporarily screwed into the extractor hole. Fit the nine retaining bolts and their lockplates, tighten the bolts evenly to 85 to 90 lbf.ft. (115 to 120 Nm) and lock them. Refit the timing pointer.

21. **Wheelcase cover.** Pack a new oil seal with Vaseline and press it, lip inwards, flush with the front face of the cover bore if the crankshaft hub is unworn. If the hub is grooved by the previous seal, press the new seal 0.110 inch (2.8 mm) below the front face; if the hub has two grooves, press the seal fully home.

Note: Kit GA.420 is used for renewing the seal on an installed wheelcase cover. It cannot be used if the cover is detached. See Section 12.

Fit the crankshaft hub rear cone. This can be assembled and removed with the wheelcase cover installed, but fitting at this stage is preferable.

Remove the idler gear axle support plate from the wheelcase cover and clean the joint faces. Oil the gear train and, using a new joint washer, fit the wheelcase cover. The locating of the fitted bolts is shown in fig. 10.

Measure the end float of the idler gear in the following manner:

- (a) Push the gear fully inwards and measure the protrusion of the front face of the gear bearing beyond the support plate joint face.
- (b) Measure the depth of the counterbored thrust face in the support plate.
- (c) Subtract (a) from (b) to obtain the end float. Limits are 0.013 to 0.027 inch (0.33 to 0.68 mm).

Apply 'Wellseal' to the joint faces, and refit the idler axle support plate, with no joint washer.

INVERT THE ENGINE

22. **Sump.** Fit the relief valve assembly and oil gallery pipes (see fig. 23) using new joints and 'O' rings. Coat sump and crankcase joint faces thinly with 'Wellseal', attach a new joint washer and temporarily fit a $\frac{1}{4}$ inch UNF guide pin of suitable length (dependent on sump type) at each corner of the crankcase joint face. Lower the sump into position on the pins, fit the setbolts, each with a plain and spring washer, and tighten them evenly. Tighten the sump drain plug to between 80 and 85 lbf.ft. (110 to 115 Nm) and wire-lock it.

TURN THE ENGINE UPRIGHT

23. **Crankshaft front end.** A typical assembly is illustrated in fig. 24, and consists of the hub (with its cones, retaining nut and lockplate), the pulley/damper unit and barring adaptor. On some applications the barring adaptor is replaced by a starter claw which is an extension of the hub nut.

Thoroughly clean all parts, apply a very thin film of grease to the hub bore splines, oil the hub nut thread and fit the hub, steel cone and hub nut. Tighten the nut to 700 lbf.ft. (950 Nm), either

Printed in Great Britain

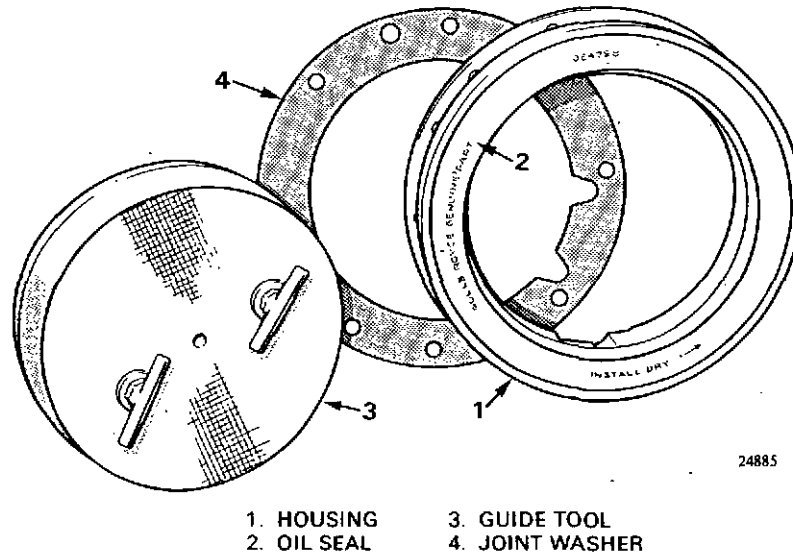

Fig. 22 Crankshaft rear seal

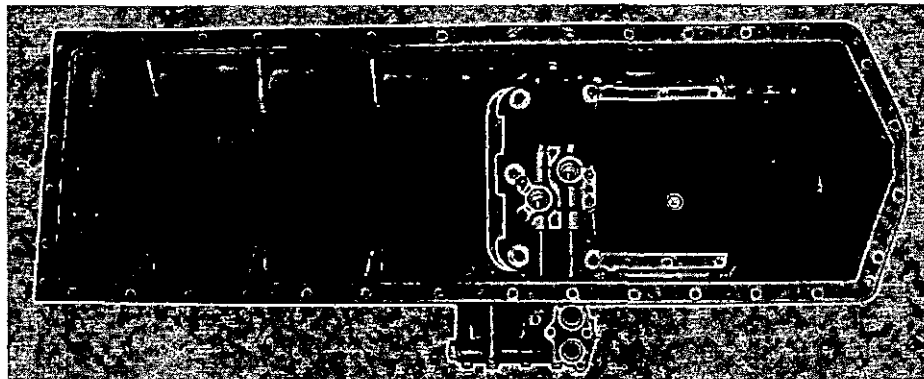

Fig. 23 Interior, forward pannier sump

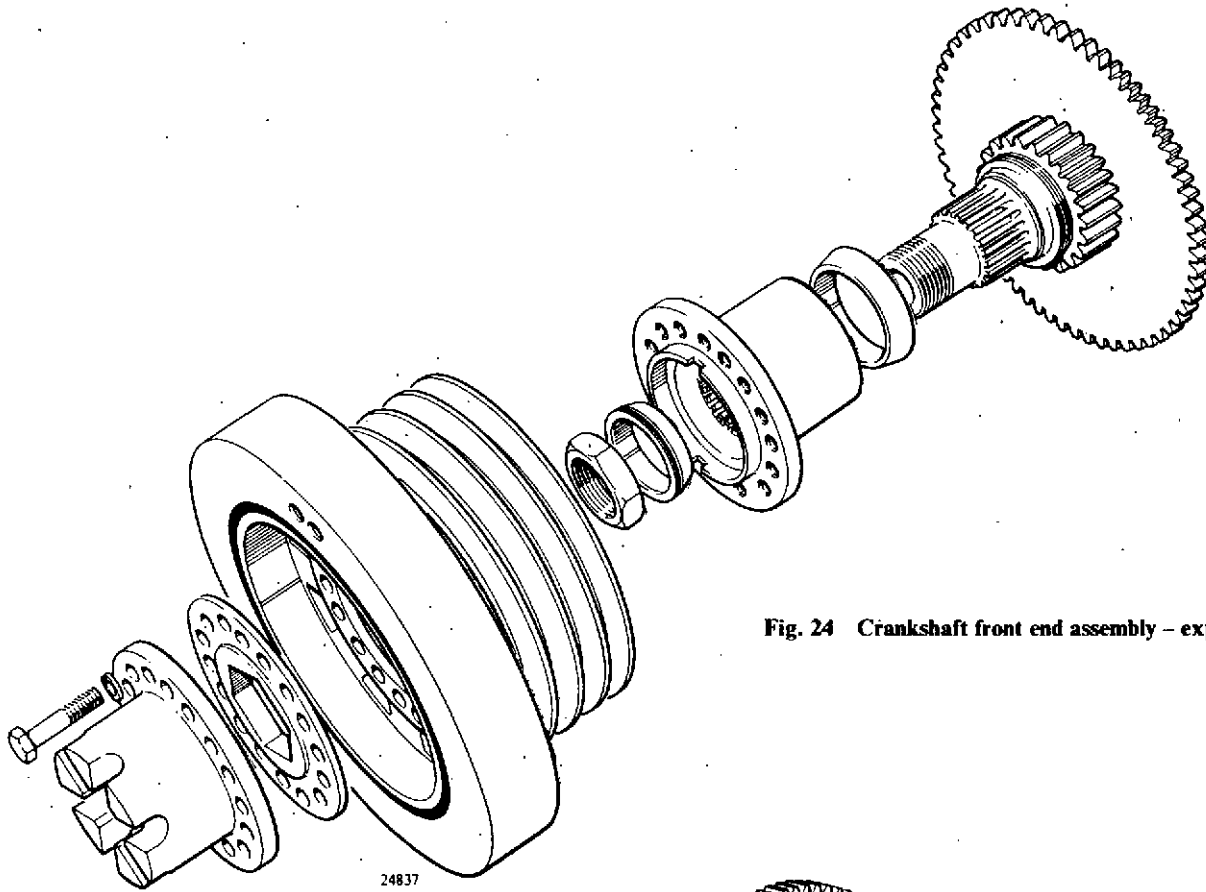
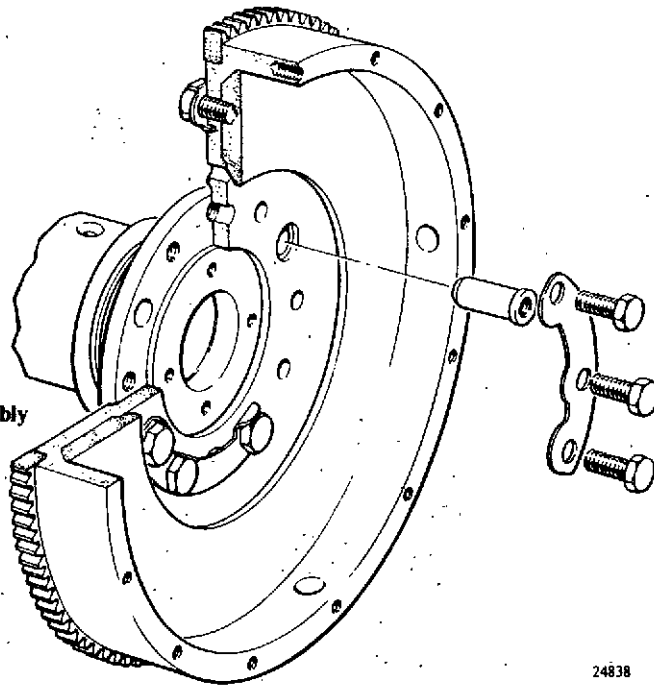

Fig. 24 Crankshaft front end assembly - exploded

24837

Fig. 25 Crankshaft rear end assembly



24838

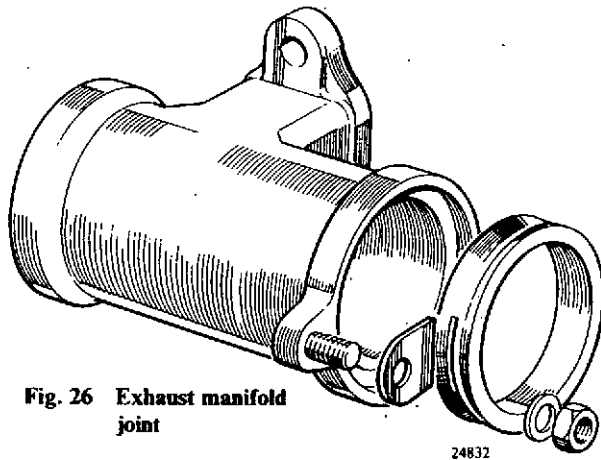

Fig. 26 Exhaust manifold joint

by torque spanner or alternatively by the following method using spanner GA.736 and a 4lb (1.8kg) hammer:

- (a) Spanner-tighten the nut as fully as possible *by hand*.
- (b) Hammer-tighten the nut *exactly* one flat further.
- (c) If the crankshaft pinion has been disturbed, slacken the nut and repeat (a) and (b).

Note: Insufficient tightening can result in fretting of splines and cone faces.

Fit pulley/damper unit, lockplate and, if applicable, barring adaptor. These components are all secured to the hub by 16 set-bolts which are tightened to 30lbf.ft. (40Nm) and locked by spring washers. If difficulty in fitting the lockplate is experienced the hub nut may be tightened further by the minimum amount necessary, but it must NOT be slackened for this purpose.

24. **Manifolds and coolant rail.** Fit the exhaust manifold, with a light smear of anti-seize compound on the screw threads. Each intersection sealing ring is assembled with its lockplate slot offset towards the lockplate stud boss (fig. 26).

No joints are used between exhaust manifold and cylinder heads.

Fit the inlet manifold, with new joint washers. Assemble the coolant rail, using new 'O' rings, and bolt it into position.

25. **Coolant pump.** Loosely fit the hoses and clips. Screw guide pins into two of the pump bolt tappings in the crankcase. Fit a new joint, using 'Wellseal', and slide the pump along the pins until the coolant rail enters the thermostat hose. Fit the retaining bolts and tighten the hose clips.
26. **Heat exchanger.** Bolt the mounting plate to the crankcase and then secure the heat exchanger to the plate.
27. **Starter motor.** Ensure that the joint faces are clean, and tighten the setbolts firmly.
28. **Oil filters.** Ensure that new elements are fitted and that the filter bowls are primed with oil. Tighten the bowl-securing bolts to 20lbf.ft. (27Nm).
29. **Fuel filter.** Fit the filter unit and its mounting bar, together with the extended studs which carry the high-pressure pipe clips.
30. **Injection pump.** Fit the two dowels to the pump mounting and bolt it to the crankcase. Note that the access hole in the mounting is opposite the lateral bolt of the centre main bearing. Assemble the injection pump to its mounting, fitting the four retaining bolts finger-tight. Do NOT connect any rigid pipes to the pump or governor at this stage. Fit the drive coupling arm to the injection pump camshaft and tighten its nut to between 85 and 90lbf.ft. (115 to 120Nm). This nut is locked by a flat spring washer.

Note: Ensure by blueing that the tapers of these drive coupling arms have a *minimum* of 80% contact.

Bar over the engine in direction of rotation until No.1 inlet valve closes, and continue turning until the injection timing figure, on the engine flywheel, as stamped on the crankcase data plate, is opposite the pointer (fig. 27).

Set the adjustable coupling of the injection pump to mid-point of its range (fig. 28 Item 2). Turn the pump until its timing marks are aligned (fig. 28 Item 3) and fit the coupling yoke and spring packs between pump and drive-shaft. Note that it is important to fit bolts with their heads to the fuel pump, as shown in Fig. 28 Item 1.

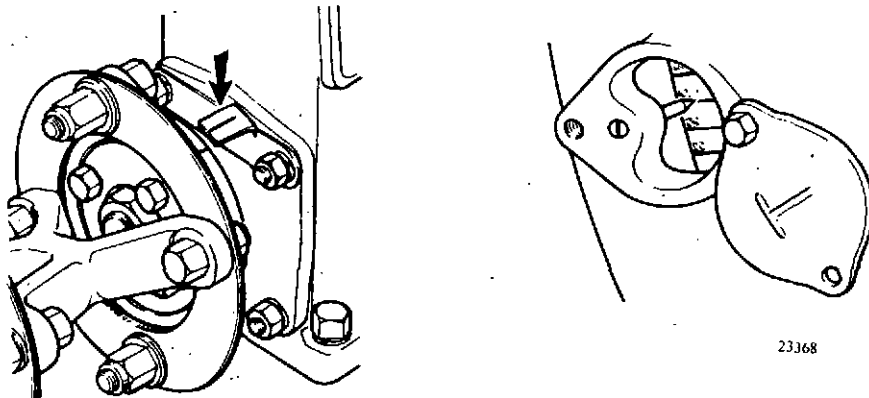

Fig. 27 Injection pump timing

Tighten the stiffnuts until the spring packs are just nipped, then continue tightening progressively, turning the engine during the early stages to enable the drive and pump to take up unstressed positions. Finally, tighten the nuts to 85 lb.ft. (115Nm) using spanner GA.733.

Evenly tighten the four pump-to-mounting bolts to 30 lb.ft. (40Nm) and, on completion, check visually that the spring packs are not distorted.

Turn the engine backwards a little to take up the backlash, and then forwards until the engine flywheel timing figure is again aligned with its pointer. Check that the pump timing marks are aligned (fig. 28).

If necessary, slacken the adjustable coupling bolts (fig. 28), align the pump timing marks, nip the bolts and carry out a further check.

Finally, tighten the adjustable coupling bolts and fit the timing pointer cover to the flywheel housing.

Fit the pump lubricating oil supply and drain pipes, and pour $\frac{1}{4}$ pint (0.4 litre) of engine lubricating oil into the pump cambox, via the filler plug on the governor housing.

31. **Injectors.** Ensure that the seatings and injector nozzles are clean, and lightly smear the injector body with coppaslip anti-seize compound. Fit the injectors with new rubber seals OE.48293 and tighten down the retaining setscrews to 8.5 lb.ft. (11 Nm); using spanner OE.3311.

Caution: No joint washer is used between injector nozzle and seating. Any washers supplied with injectors must be removed and discarded. Coppaslip **MUST NOT** be applied around the injector nozzle area.

32. **Injection pipes.** The high-pressure pipes in particular must be treated with great care and not strained or forced into position. When fitting each pipe, blow through it with dry compressed air and ensure that it lies naturally between its unions so that no distortion of pipe or rubber dampers occurs when the gland nuts and securing clips are tightened. **DO NOT OVERTIGHTEN THE GLAND NUTS.**

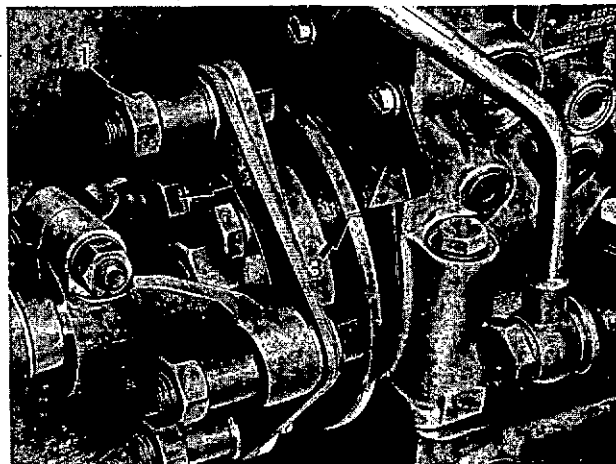

Fig. 28 Adjustable coupling

T720079

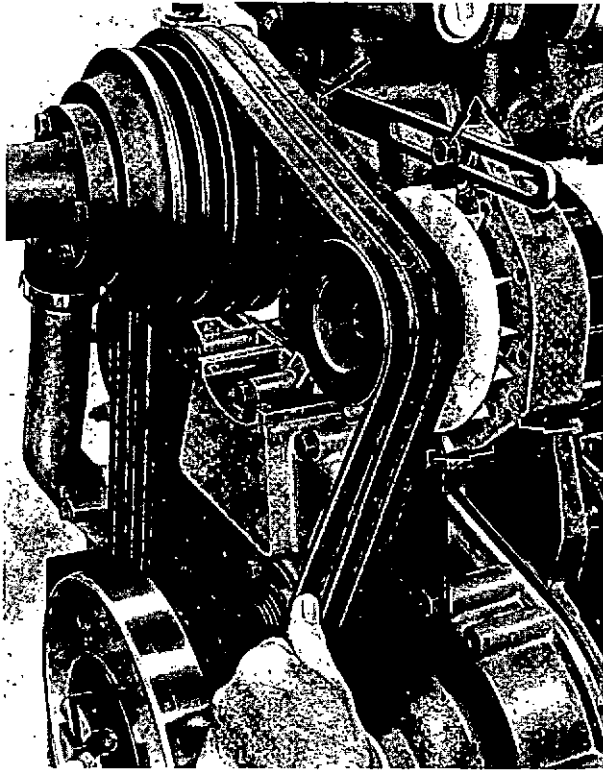

Fig. 29 Belt adjustment

T720080

Use new joint washers at each of the spill pipe banjo connections.

33. Alternator and driving belts.

Fit the alternator and swivel it inwards on its pivot until the belts can be fitted easily by hand. Do not lever belts into position.

To ensure maximum life for belts and the bearings of alternator and coolant pump it is essential that each belt is correctly tensioned and the pulleys are aligned. On a multi-belt drive, all belts must be renewed together.

Adjustment of main belt tension is made by slackening the bolts indicated by arrows in fig. 29 and swivelling the alternator about its pivot. Belts are supplied in sets, all belts in a set being exactly of equal length. Belts from different sets must NOT be mixed, since they will not necessarily be of equal length. These belts must be tensioned so that on each belt the deflection at mid-point of the longest run is $\frac{1}{4}$ inch (12mm) under a pressure of 8.5 to 9.5 lb. (3.85 to 4.3 kg).

Alignment of the alternator and coolant pump pulleys is checked, after the belts are tensioned, by placing a straightedge across the front faces of both pulleys and measuring by feeler gauge. Misalignment must not exceed 0.025 inch (0.6mm) and is corrected by spacing washers fitted behind the alternator pulley. Use wrench OE.44083 to hold the pulley whilst slackening its nut, and withdraw the pulley from its parallel shaft using extractor OE.44398. When refitting the pulley, tighten the nut to 40 lbf.ft. (55 Nm).

Checking new belts

New belts should be checked, and adjusted if necessary, after the first 15 minutes running, then weekly for the first four weeks, and thereafter at the intervals specified in the Servicing Schedule.

- 34. Turbocharger.** No joint washer is used between exhaust manifold and turbocharger, and it is therefore essential that the contacting faces are clean and flat. Fit new hose connections of the approved reinforced silicone type to the induction side, ensuring that they are properly aligned and firmly clipped.

Apply a light coating of anti-seize compound (see Section 1) to all bolts and nuts before assembling the unit to the engine. If a bellows-type diffuser is fitted ensure that it is properly aligned to avoid distortion which could cause early failure. Before fitting the lubricating oil feed and drain pipes, check them for damage and restrictions.

Prime the turbocharger bearings by pouring $\frac{1}{2}$ pint (0.2 litre) of engine lubricating oil into the filler pipe on the bearing housing.

Note: Although the turbocharger is simple in principle and construction, it is, in fact, a precision-built machine operating at very high speeds. Its performance and life are dependent on correct operation and efficient servicing. During test-running of new and overhauled engines at the Factory a special 'throw-away' filter OE.43712 is fitted at the turbocharger oil inlet flange; this protects the turbocharger bearings against contamination during initial running and is then removed and destroyed. Distributors wishing to adopt this precaution are reminded that (1) the filter must be removed before the engine goes into

service and (2) the filter cannot be cleaned and must be destroyed on removal to ensure that it is not re-used. See Section 15 'Running-in'.

35. **Miscellaneous.** Make a final check to ensure that all pipes are adequately supported and not liable to chafing. Blank off all orifices.

SPECIAL TOOLS

- | | | | |
|----------|--|---------|--|
| J.47967 | Engine turnover stand | GA.420 | Kit, renewing crankshaft front seal on installed wheelcase, consisting of: |
| J.52673 | Temporary bearer brackets (4 off) | GA.364 | Extractor |
| J.47783 | Crankcase lifting tackle | GA.694 | Inserting tool |
| J.47789 | Slings beam, crankshaft | GA.421 | Box |
| GA.13 | Lifting attachment, cylinder head | GA.623 | Tool, cam follower retaining (2 off) |
| GA.16 | Slings eye, flywheel | GA.12 | Tool, piston ring compressing |
| OE.40897 | Torque spanner, 4 to 25 lbf.ft. | GA.65 | Kit, piston height (special order) |
| DV.1978 | Torque spanner, 20 to 100 lbf.ft. | GA.693 | Datum tool, piston height |
| OE.40898 | Torque spanner, 50 to 250 lbf.ft. | GA.45 | Plug, sealing idler gear axle bore, oil pressure test |
| GA.629 | Insertion/extraction tool, cylinder liners | GA.256 | Guide-bars flywheel removal (2 off) |
| GA.2/M2 | Insertion/extraction tool, main bearing caps | GA.687 | Guide-bars, flywheel fitting (2 off) |
| GA.21 | Extension spanner, main bearing capnuts | GA.736 | Spanner, crankshaft hub nut |
| GA.497 | Tab bender, main bearing nuts | OE.3311 | Spanner, injector flange nuts |
| GA.668 | Stiffening frame, wheelcase backplate | | |

SECTION 4—CRANKCASE AND CYLINDERS

DESCRIPTION

The crankcase comprises the crank chamber and cylinder block, cast as a single unit in high-grade nickel-chrome iron. The crank chamber extends well below the crankshaft centre line to ensure rigidity, and incorporates five transverse webs which carry the centre and intermediate bearings of the crankshaft. Additional stiffness is provided by lateral setbolts at the front, centre and rear main bearing caps (see Section 2 fig. 6).

The crankshaft is carried in seven plain bearings with removable caps, and is located by thrust washers at the centre bearing. The camshaft has seven journals and runs in bearing surfaces machined in the crankcase casting.

Slip-fit wet liners are carried in the cylinder block, which has cast-in webs to control coolant circulation. At the top of each liner is a flange, the underside of which forms a coolant seal with the seat of a counter-bore in the crankcase top face. At its skirt the liner is grooved for three composition sealing rings.

Cam followers of chilled cast iron are carried in machined bores adjacent to the crankcase webs. All oilways are drilled for cleanliness and uniformity, and the crankcase interior surface is sealed to prevent contamination of lubricating oil and coolant by casting residue.

INSPECTION AND TESTING

Remove all blanking plugs and thoroughly clean the crankcase, paying particular attention to oilways. Refit the coolant plugs to the cylinder block, applying Loctite '225' to their threads and using new joint washers:

Pressure test

To test for cracks, fit the blanking-off assembly GA.486, immerse the crankcase in water at 60 deg.C (140 deg.F) for 20 minutes, apply air pressure at 30 lbf./sq. inch (206 kN/sq.m) and examine for leaks.

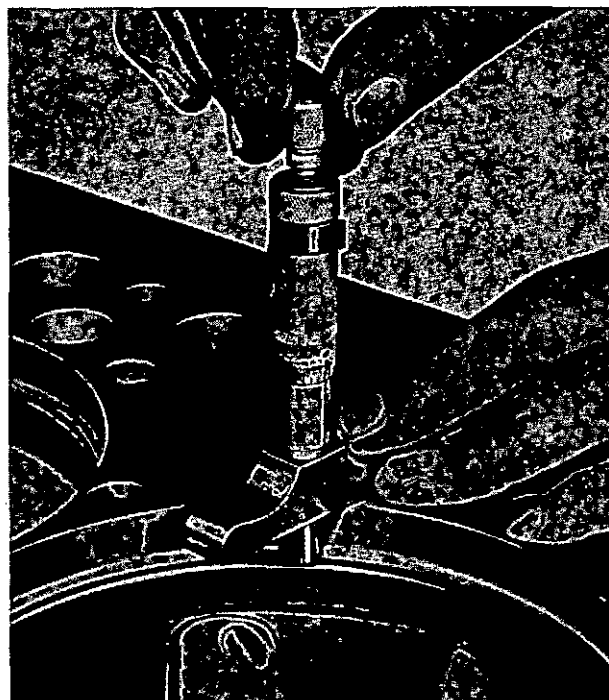

Fig. 1 Measuring depth of liner flange seating.

2876

Top face

Eroded bobbin recesses will necessitate returning the crankcase to the factory for reclamation. Inspect the top face for signs of fretting by the cylinder heads. This face may be reclaimed by machining, subject to the following limitations. See SRS 32 for details:

1. The amount of metal removed should be the minimum necessary to restore the surface, and must not exceed 0.020 inch (0.51 mm), measured from standard. After machining, the appropriate figure is stamped on the top face in an area not covered by the cylinder heads.
2. Clearance of 0.012 to 0.015 inch (0.30 to 0.38 mm.) between crankcase top face and piston crowns at TDC must be maintained, if necessary by machining the pistons. See Section 3, Item 13.
3. Whatever amount is removed from the top face, the depths of bobbin and cylinder liner recesses must be maintained.

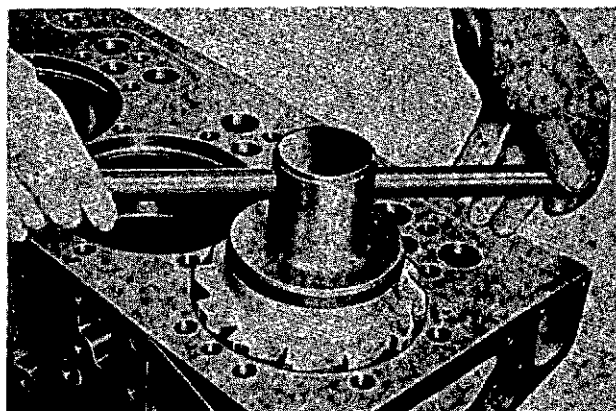

Fig. 2 Cutting liner flange seating

2877

Liner recesses

Inspect each liner flange seating for fretting and, to confirm that the seal is satisfactory, check by 'blueing' that contact between liner flange and seating is 100% of circumference and at least 50% of width.

Measure the depth of each flange seating below the top face at four equidistant points (fig. 1) and record the readings. Use cutter GA. 320 (fig. 2) to reclaim unsatisfactory seatings, or to restore seating depth after machining of the top face.

Reclamation of the flange seating will reduce the protrusion of the cylinder liner above the crankcase top face. To restore this protrusion to its limits of 0.003 to 0.005 inch (0.08 to 0.13mm.) proceed as follows:

1. If the cylinder liner flange is of standard thickness, a special liner, having a flange 0.005 inch (0.13 mm.) thicker, is available. This liner is identified by a 'V' groove on the flange circumference. Note that when a new liner is fitted, the piston rings should also be renewed.
2. If the protrusion cannot be restored by the above method, the necessary amount must be machined from the crankcase top face (see SRS 32).

Liner lower sealing bores

Inspect the bores in the crankcase for erosion and damage. Instructions for repair, which involves machining the bore and fitting a stainless steel sleeve, are given in SRS 17 (issue 5).

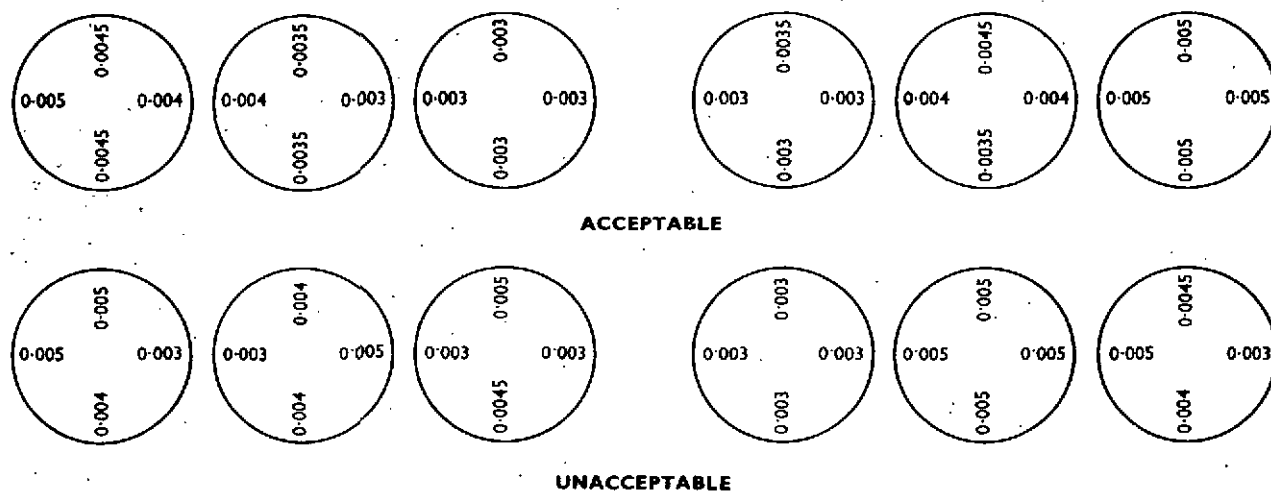

Fig. 3 Acceptable and unacceptable protrusions of cylinder liners

5895A

Cylinder liners

After thorough cleaning, inspect the top flange for fretting and the coolant surfaces for erosion and pitting, particularly in the area of the sealing ring grooves. Inspect and measure the bores. Carry out a crack test. Finally, check that the flange makes satisfactory contact with its seating, as previously described.

Liners have three grooves machined in the skirt to accommodate composition sealing rings. The current part number for the sealing ring is OE 46017 and bears a blue-and-white paint marking for identification.

Cylinder liner protrusion

Carefully fit the liners to the crankcase, *without sealing rings*, and with their etched Position Numbers to the large coolant port (see Section 3. fig. 14). Measure the protrusion of each liner flange above the crankcase top face at four equally spaced points. Limits are 0.003 to 0.005 inch (0.08 to 0.13 mm) and the protrusions must also conform to the following requirements as shown in fig. 3:

1. Maximum variation of 0.001 inch (0.025 mm) between highest and lowest on any one liner flange.
2. Maximum variation of 0.001 inch (0.025 mm) between protrusions at *adjacent* points on flanges of neighbouring liners.

Rectify incorrect protrusions as described under 'Liner recesses' earlier in this Section.

Note: If a new liner is being fitted, etch its Position Number on the flange, opposite the large coolant port (see Section 3. fig. 14), when the protrusion check is satisfactorily completed.

Assembling liner to crankcase

The method of fitting the sealing rings to the liner skirt and finally assembling a liner to the crankcase is illustrated and described in the early stages of Section 3 'ASSEMBLING THE ENGINE'.

Main bearings

Measure the lateral width of the bearing caps and their locations. Assemble them to the crankcase and measure the bearing bores. Refer to SRS 101 for details of reclaiming malaligned bores. See Section 6 for dimensional check of centre bearing and thrust washers.

Cam followers

Inspect the followers for wear and scuffing, and check each in its bore. Slight damage may be stoned out if a follower is otherwise serviceable.

SPECIAL TOOLS

- | | |
|--------|------------------------------|
| GA 486 | Pressure test assembly |
| GA 320 | Cutter, liner flange seating |

SERVICE RECLAMATION SCHEMES

- | | |
|------------------|---|
| SRS 17 (Issue 5) | Reclamation of liner lower sealing bore in crankcase |
| SRS 32 | Reclamation of crankcase top face |
| SRS 101 | Reclamation of crank journals and crankpins, and reboring of main bearing housings. |



Printed in Great Britain

FITS AND CLEARANCES

CRANKCASE AND CYLINDER LINERS

ROLLS-ROYCE DIESELS

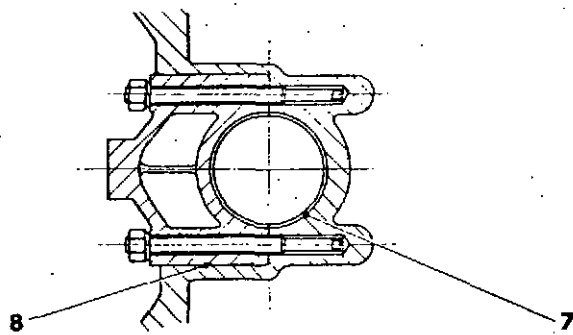
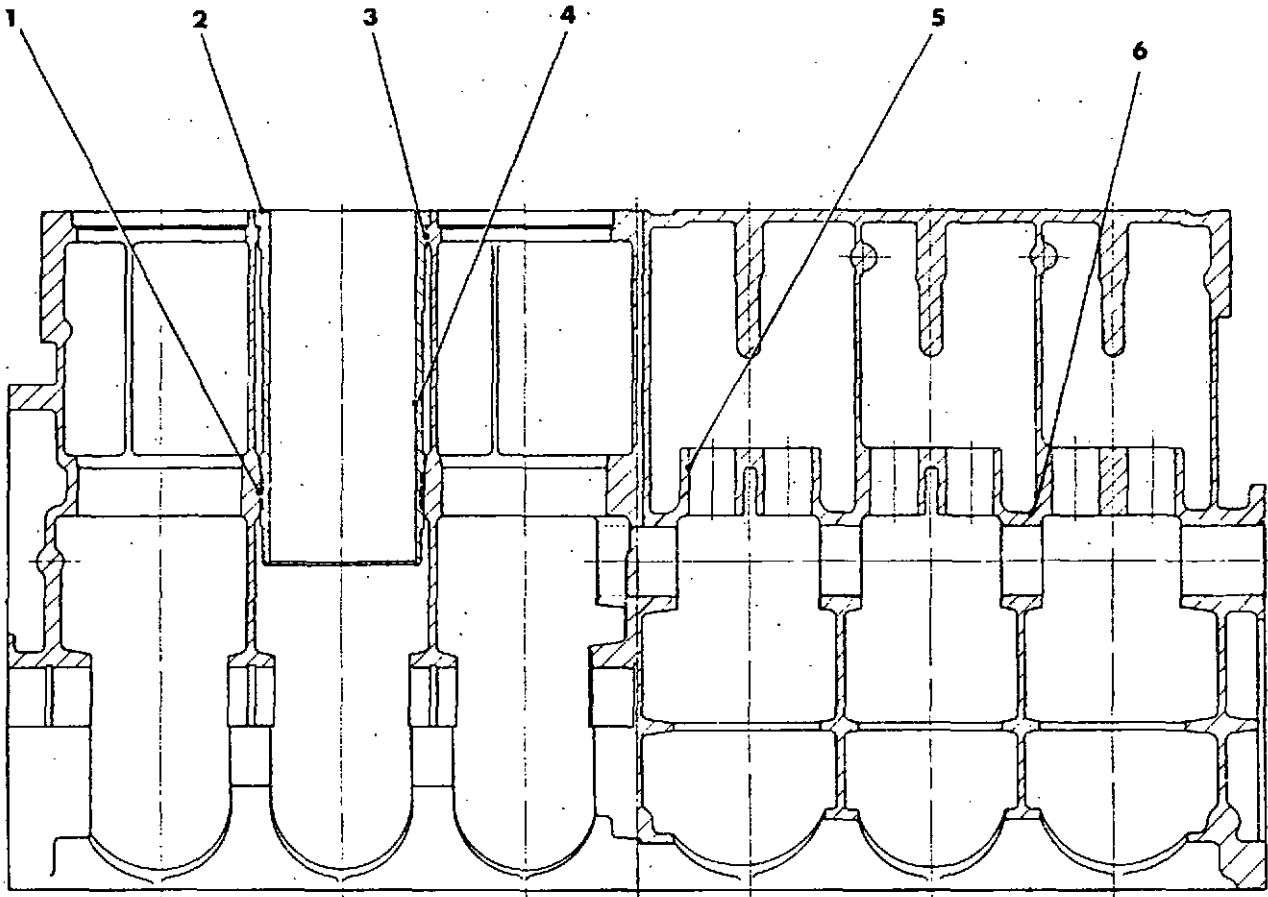

24882

ROLLS-ROYCE DIESELS

Printed in Great Britain

No. ON DIAG.	DESCRIPTION	DIMENSIONS NEW		PERMISSIBLE WORN DIMENSIONS		CLEARANCE NEW		PERMISSIBLE WORN CLEARANCE		REMARKS
		in.	mm.	in.	mm.	in.	mm.	in.	mm.	
1	CYLINDER LINER IN CRANKCASE Liner skirt in crankcase Crankcase—lower bore	5.676 to 5.677	144.17 to 144.20			0.003 to 0.005	0.08 to 0.13			For reclamation of eroded bore, see SRS 17 (Issue 5)
		5.672 to 5.673	144.07 to 144.09							
2	Liner skirt—diameter Protrusion of liner above crankcase face Crankcase counterbore—depth	0.495 to 0.496	12.57 to 12.60							See text and SRS 32 for limitations and reclamation details
		0.499 to 0.500	12.68 to 12.70			Proud 0.003 to 0.005 Proud	0.08 to 0.13			
3	Liner in crankcase Crankcase—upper bore Liner—diameter	5.778 to 5.779	146.76 to 146.78			0.002 to 0.004	0.05 to 0.10			See also 'Pistons' in Section 7
		5.775 to 5.776	146.68 to 146.71							
4	CYLINDER LINER OUT OF CRANKCASE Liner—bore	5.125 to 5.126	130.17 to 130.20	5.137	130.48					

ROLLS-ROYCE DIESELS

No. ON DIAG.	DESCRIPTION	DIMENSIONS NEW		PERMISSIBLE WORN DIMENSIONS		CLEARANCE NEW		PERMISSIBLE WORN CLEARANCE		REMARKS
		in.	mm.	in.	mm.	in.	mm.	in.	mm.	
5	CAM FOLLOWER IN CRANKCASE Crankcase bore	1-625 to	41-27 to			0-002 to	0-05 to			
		1-626	41-30			0-0035	0-09			
6	Cam follower—dia.	1-6225 to	41-21 to					0-004	0-10	
		1-623	41-22							
7	CAMSHAFT BEARINGS IN CRANKCASE Crankcase bore	2-5995 to	66-03 to							See Section 5 for fit of camshaft in bearings
		2-6005	66-05			Interference				
		2-603 to	66-12 to			0-0055 to	0-14			
		2-605	66-17			0-0025 to	0-06			
8	MAIN BEARING HOUSING IN CRANKCASE Bearing housing—bore	4-100 to	104-14 to							See SRS 101 for details of boring oversize
		4-101	104-16							
9	BEARING CAPS IN CRANKCASE Bearing cap location—width	6-625 to	168-27 to							
		6-626	168-30			Interference				
10	Bearing cap—width	6-625 to	168-27 to			0-0005 to	0-013			
		6-6255	168-29			0-001 to	0-025			

SECTION 5—CAMSHAFT

Printed in Great Britain

DESCRIPTION

The camshaft has seven journals and runs in bearing surfaces machined in the parent crankcase metal, without conventional bushes.

It is gear-driven at one-half engine speed, via an idler gear in mesh with the crankshaft pinion, and the gear-wheel teeth are marked to facilitate timing (see Section 3, fig. 9).

The drivegear is located by offset roll-pins and bolted to the front of the camshaft, end float being controlled by a phosphor-bronze thrust plate (see Section 3, fig. 7).

A drilling throughout the length of the camshaft is blanked off at the front by an aluminium plug and 'O' ring, and at the rear by a screwed plug locked by a tabwasher.

Oil under pressure enters the camshaft at its centre journal and emerges from cross-drillings at the remaining journals. The rear journal also has a small longitudinal drilling to prevent pressure build-up in its bearing housing, which is blanked off.

INSPECTION

Remove the end plugs and clean the camshaft bore. The front plug has a $\frac{1}{16}$ inch UNF tapping for extraction purposes. Carry out a crack test on camshaft and drivegear, preferably by an electromagnetic method.

Inspect the cams, journals and thrust face for wear and damage, measuring the lift of each cam. Slight scoring may be stoned out, provided that the cam profile is unaffected. If wear exceeds the limits quoted at the end of this Section the camshaft must be renewed.

Inspect the drivegear teeth and thrust face for wear and damage. Measure the thickness of the phosphor-bronze thrust plate at its contact area.

When refitting the camshaft end plugs apply Loctite '225' to the thread of the screwed plug, tighten the plug firmly and bend up its tabwasher; fit a new 'O' ring to the aluminium plug, oil it and fit the plug with the extractor tapping outwards.

Information concerning cam followers is given in Section 4.



Printed in Great Britain

FITS AND CLEARANCES

CAMSHAFT

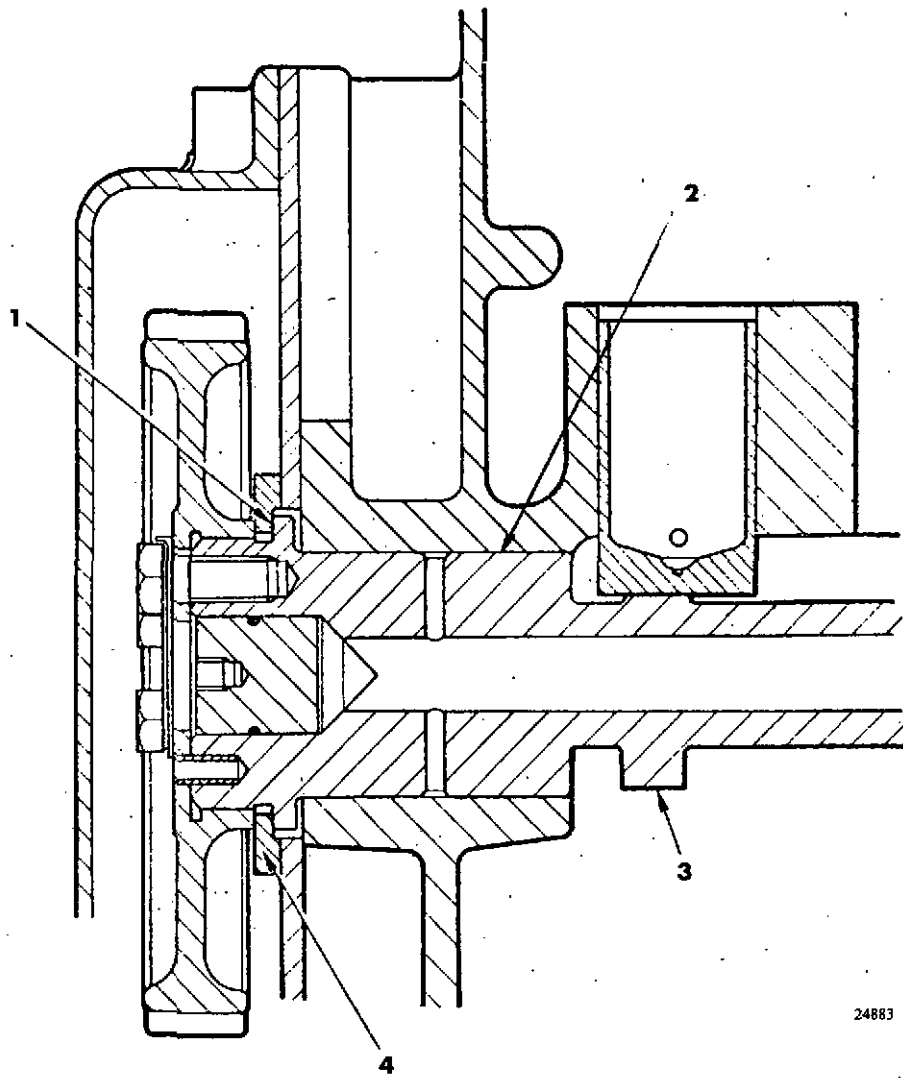

24883

No. ON DIAG.	DESCRIPTION	DIMENSIONS NEW		PERMISSIBLE WORN DIMENSIONS		CLEARANCE NEW		PERMISSIBLE WORN CLEARANCE		REMARKS		
		in.	mm.	in.	mm.	in.	mm.	in.	mm.			
1	CAMSHAFT & BEARINGS Camshaft end float											
2	Camshaft—diameter	2.5955 to 2.596	65.92 to 66.03					0.004 to 0.010	0.10 to 0.25	0.031	0.79	See Item 4
3	Cam lift—inlet —exhaust	0.388 to 0.390 0.391 to 0.393	9.85 to 9.91 9.93 to 9.98	0.370	9.40							
4	Thrust plate—thickness at contact area	0.193 to 0.196	4.90 to 4.98	0.183	4.65							



SECTION 6—CRANKSHAFT, MAIN BEARINGS, FLYWHEEL

DESCRIPTION

The crankshaft is forged from chrome-molybdenum steel and dynamically balanced. All bearing surfaces are nitride-hardened and lapped to size. The seven main bearings are pressure-fed with oil from a gallery pipe bolted to the bearing caps and, except from the centre bearing, a drilling from each journal conveys oil to an adjacent crankpin which incorporates a sludge-trap with detachable plug.

End float is controlled about the centre bearing by steel-backed lead bronze thrust washers. At the rear of the crankshaft are an oil thrower, a scroll-type seal and a mounting flange for the flywheel. The nose of the crankshaft carries the oil pump drive-gear and the main pinion, and is splined to receive a hub to which the pulley, damper and barring adaptor are bolted. Main bearings are pre-finished steel-backed lead-bronze shells with lead overlay, indium-flashed.

The flywheel is spigot mounted, located by three dowels (one offset) and retained by nine setbolts with

lockplates: their torque-loading, with oiled threads is 85 to 90 lbf.ft. (115 to 120 Nm). A starter gear ring is shrunk on to the forward edge.

DISMANTLING

Screw extractor GA.17 on the pinion thread and withdraw the pinion (fig. 1). Remove the Woodruff keys, and tap the oil pump drivegear forward to detach it from its dowels.

To extract a sludge trap plug (fig. 2), drive it inwards slightly, remove the circlip using levers GA.716 and withdraw the plug by means of its $\frac{1}{16}$ inch UNF tapped hole, using either extractor GA.171 or a long bolt and sliding weight.

CRANKSHAFT AND BEARINGS

Thoroughly clean all components, with particular attention to the crankshaft oilways.

Crankshaft

Carry out a crack test, preferably by an electromagnetic process, on the shaft, pinion and oil pump drivegear. Inspect the journals and crankpins for scoring, and measure their diameters. Regrinding is permissible in four stages, each of 0.010 inch (0.25 mm.) on diameter. Re-nitriding is necessary at the minus 0.020 inch (0.51 mm.) and minus 0.040 inch (1.02 mm.) stages. See SRS 101 for details of grinding and nitriding operations.

Check the crankshaft for 'bow' with the front and rear journals mounted in 'V' blocks. The permissible bow must be progressive along the length of the shaft.

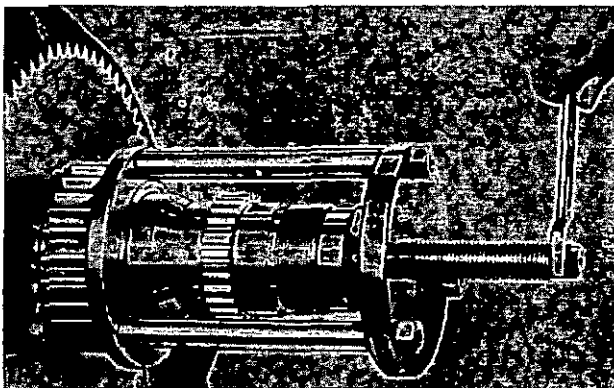

Fig. 1 Withdrawing crankshaft pinion

1704

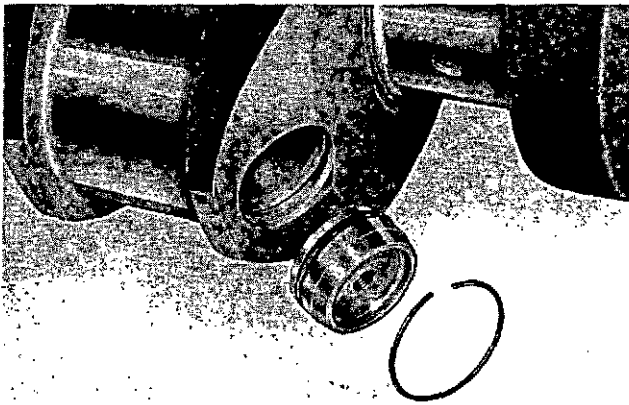

Fig. 2 Crankshaft sludge trap plug T720051

Measure the length of the centre journal and the width of the centre bearing (including thrust washers), and calculate the end float. If beyond limits with new washers, see SRS 8.

Inspect the crankshaft generally for damage to screwthreads, keyways, dowel holes and oil seal scroll. Check the rear flange, the pinion area and the splines for fretting. Inspect the teeth of the pinion and the oil pump drivegear.

Refit the sludge trap plugs, using new 'O' rings. Oil the bores, press each plug into its housing with tool GA 171, fit the circlip and pull the plug back against it. Position the oil pump drivegear on its dowels, insert the Woodruff keys and fit the pinion, ensuring that its alignment dot coincides with the punch-mark on the crankshaft nose (see Section 3, fig. 9).

Bearings

Inspect for wear, cracks and embedded foreign matter. It is advisable to renew any bearing if there is the slightest doubt that it will complete a further full period of service.

FLYWHEEL

Inspect the clutch friction face for wear and scores. If the face is integral with the flywheel it may be

reclaimed by grinding up to 0.025 inch (0.63 mm.) from standard, subject to fitting of a new centre plate and satisfactory maintenance of other clutch clearances. Some flywheels have a renewable friction face, secured by eight setbolts, $\frac{5}{16}$ -inch UNC or $\frac{3}{8}$ -inch UNF, according to specification. These setbolts are tightened to 18 lbf.ft. (2.5 kg.m.) and 33 lbf.ft. (4.6 kg.m.) respectively.

Where applicable, check the fit of the pilot shaft bearing in the flywheel bore (see SRS 86 for repair details).

Check bolt and dowel holes for elongation, and examine contact surfaces for fretting. Inspect the teeth of the starter ring for wear and damage.

Renewing starter ring

Drill holes in the ring body at diametrically opposite positions until it is weakened sufficiently to be driven off. Do not attempt to drill through the teeth. Ensure that the new ring and its seating are clean and free from burrs. Heat the ring evenly to 200 deg. C (292 deg. F), fit it to the flywheel and rotate it to ensure correct seating. Allow to cool naturally, and check by feeler gauge that the ring is flush with the shoulder on the flywheel.

SPECIAL TOOLS

GA 17	Extractor, crankshaft pinion
GA 171	Tool, sludge trap plugs
GA 716	Levers, sludge trap plug circlip

SERVICE RECLAMATION SCHEMES

SRS 8	Reconditioning crankshaft centre bearing thrust faces.
SRS 9	Reclaiming dowel holes in rear flange.
SRS 101	Reclaiming journals and crankpins. Reboring main bearing housings.

Printed in Great Britain

FITS AND CLEARANCES

CRANKSHAFT

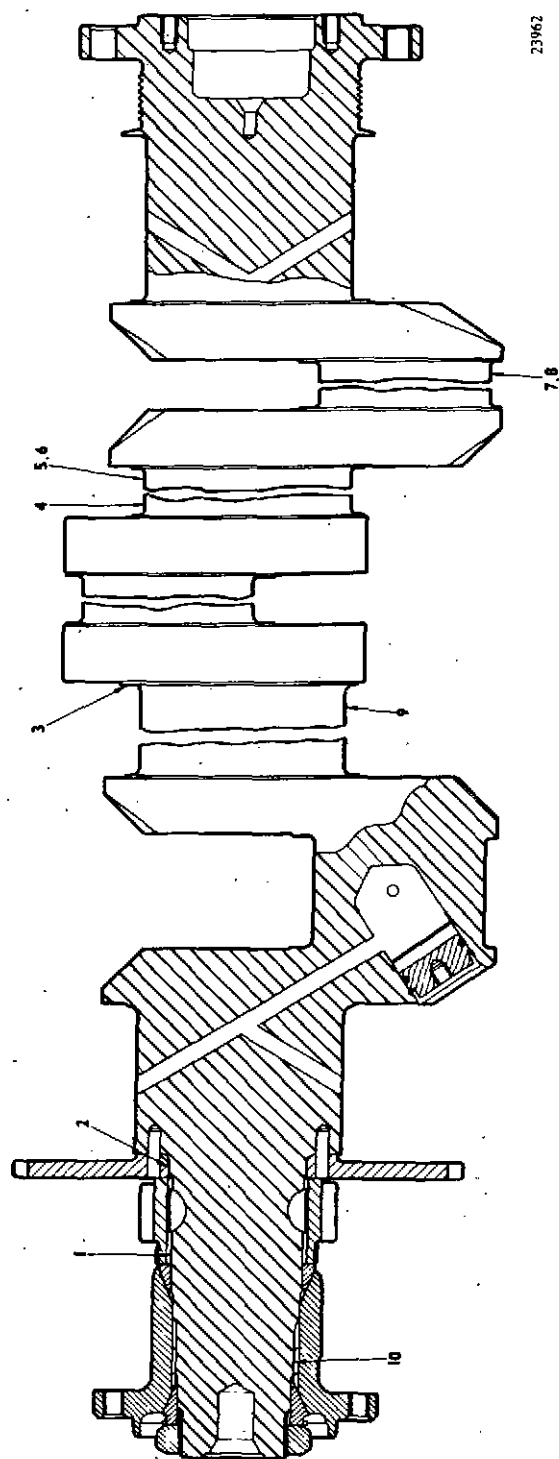

No. ON DIAG.	DESCRIPTION	DIMENSIONS NEW		PERMISSIBLE WORN DIMENSIONS		CLEARANCE NEW		PERMISSIBLE WORN CLEARANCE		REMARKS
		in.	mm.	in.	mm.	in.	mm.	in.	mm.	
1	CRANKSHAFT PINION ON CRANKSHAFT Pinion—bore Crankshaft—diameter	2.500 to 2.5005 2.499 to 2.4995	63.50 63.51 63.47 to 63.49			0.0005 to 0.0015	0.013 to 0.038			
2	OIL PUMP DRIVEGEAR ON CRANKSHAFT Gear—bore Crankshaft—diameter	2.625 to 2.6255 2.624 to 2.6245	66.67 to 66.69 66.65 to 66.66			0.0005 to 0.0015	0.013 to 0.038			
3	CRANKSHAFT END FLOAT Centre journal—length Centre bearing—width over thrust washers	3.175 to 3.177 3.164 to 3.170	80.64 to 80.69 80.36 to 80.52			0.005 to 0.013	0.13 to 0.33	0.020	0.51	See SRS 8
4	CRANKSHAFT JOURNALS Diameter	3.8995 to 3.900	99.05 to 99.06	3.897	98.98					See SRS 101
5	Ovality			0.003	0.076					
6	Journals in main bearings Running clearance					0.0035 to 0.0055	0.09 to 0.14			

ROLLS-ROYCE DIESELS

No. ON DIAG.	DESCRIPTION	DIMENSIONS NEW		PERMISSIBLE WORN DIMENSIONS		CLEARANCE NEW		PERMISSIBLE WORN CLEARANCE		REMARKS
		in.	mm.	in.	mm.	in.	mm.	in.	mm.	
7	CRANKPINS Standard size—diameter	3-249 to 3-2495	82-52 to 82-54	3-2465 0-003	82-46 0-076					See SRS 101 Total indicator reading 0-020 inch (0-51 mm.) Bow to be progressive throughout crank length
8	Ovality									
9	CRANKSHAFT BOW Bow at centre journal when supported by end journals in V-blocks			0-010	0-25					
10	CRANKSHAFT HUB Hub on crankshaft— backlash between splines					0-0005 to 0-0003	0-013 to 0-08	0-006	0-15	

SECTION 7—PISTONS AND CONNECTING RODS

PISTONS

These are of light alloy with a cast-in austenitic iron insert which carries the top ring. The piston crown is machined to form a combustion chamber, the size of which determines the compression ratio. The gudgeon pin is offset 0.062 inch (1.6 mm) from the vertical centre-line of the piston: it is fully floating and retained by circlips.

The piston assemblies used on 'C-RH' engines are illustrated in fig. 1. Details of their ring packs are as follows:

Turbocharged engines

- Top ring:* OE 46334 Molybdenum inlaid.
- 2nd ring:* OE 40750 Barrel-faced, chrome-plated internal chamfer. See Note.

3rd ring: OE 42524 Plain-faced, internal L recess. See Note.

Oil control ring: OE 39127 Chrome-plated rails. 150 lbf./sq. inch backing spring (coded yellow).

Normally-aspirated engines

Top ring: OE 48279 Molybdenum inlaid

2nd ring: OE 40750 Barrel-faced, chrome-plated, internal chamfer. See Note.

Oil control ring: OE 39127 Chrome-plated rails. 150 lbf./sq. inch backing spring (coded yellow).

Note: Rings OE 40750 and OE 42524 are fitted with their internal chamfer or recess towards the piston crown and are etched TOP or UP on the uppermost face.

Printed in Great Britain

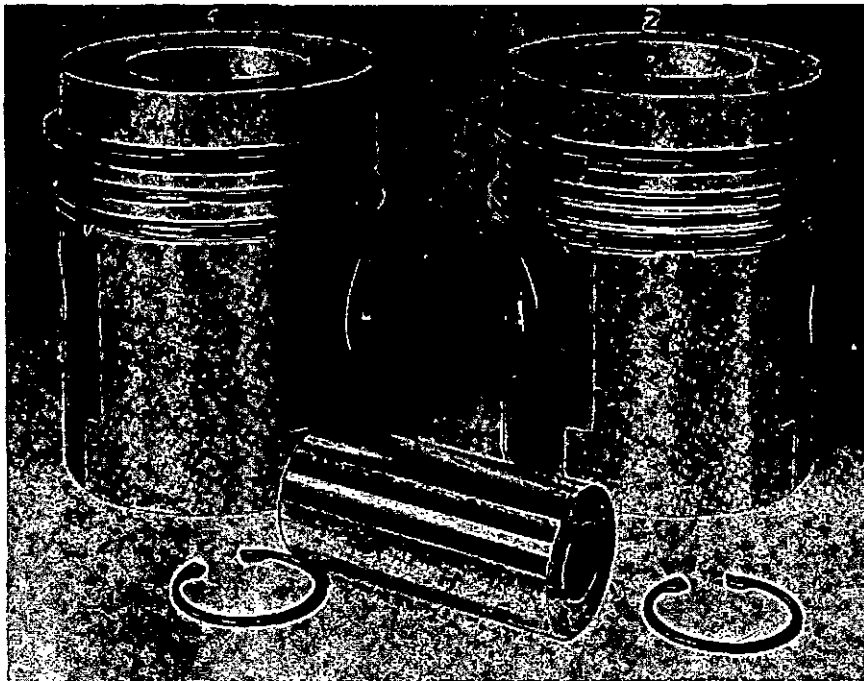

1 NORMALLY ASPIRATED ENGINES
2 TURBOCHARGED ENGINES

T720081

Fig. 1 Piston assemblies

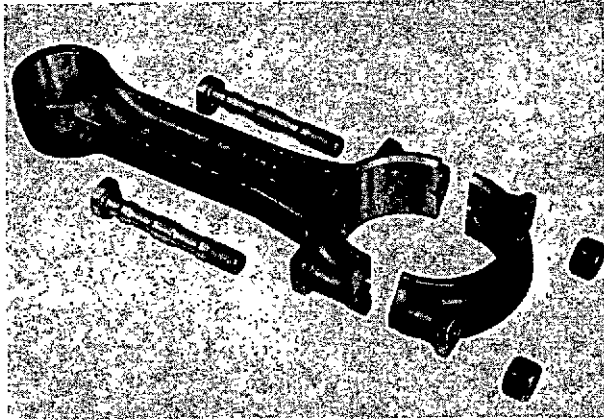

Fig. 2 Connecting rod assembly

T720053

CONNECTING RODS

These are steel forgings, drilled longitudinally for pressure lubrication of the small-end (fig. 2). Two $\frac{3}{4}$ -inch (1.2 mm.) drillings in the small-end eye direct oil jets to the ring belt area within the piston for cooling purposes. To maintain this oil supply the big-end bearing bore has a circumferential oil groove.

The big-end bearings are steel-backed lead-bronze shells with lead overlay, indium-flashed. The small-end has twin steel-backed lead-bronze bushes pressed in from either side to leave an oilway gap between them.

Each rod and its cap are stamped with correlation marks (fig. 3) and, on factory-built engines, the cylinder number. All rods are stamped with the letter of their weight group, as described later. Rod and cap are secured together by two bolts and nuts, no locking device being used. The big-end will pass through the cylinder bore.

At manufacture, all rods are weighed and classified in groups of 4 oz. (113 grammes) range, each group having an identifying letter which is stamped on the rod (fig. 3). All rods in a factory-built engine or 'short engine' are of the same weight group, and if individual rods are changed on an engine in service the order for replacements should specify the weight group letter. If the correct rod is not available, one of the nearest group may be fitted.

The weight groups are as follows:

- A 7lb. 10oz. to 7lb. 14oz. (3.46 kg. to 3.57 kg.)
- B Above A to 8lb. 2oz. (3.68 kg.)
- C Above B to 8lb. 6oz. (3.80 kg.)
- D Above C to 8lb. 10oz. (3.91 kg.)
- E Above D to 8lb. 14oz. (4.02 kg.)
- F Above E to 9lb. 2oz. (4.14 kg.)

Caution: Before fitting a replacement rod, ensure that it has the correct oilway drillings as described, and that these drillings are clear.

DISMANTLING

Using 'Seeger' pliers, remove the gudgeon pin circlips. Heat the piston in oil or water and push out the gudgeon pin sufficiently to release the connecting rod. Remove the piston rings, using pliers GA 612 and locating ring GA 617 (fig. 4). Ensure that gudgeon pin and rings are identified with their piston.



Fig. 3 Correlation marks

T720054

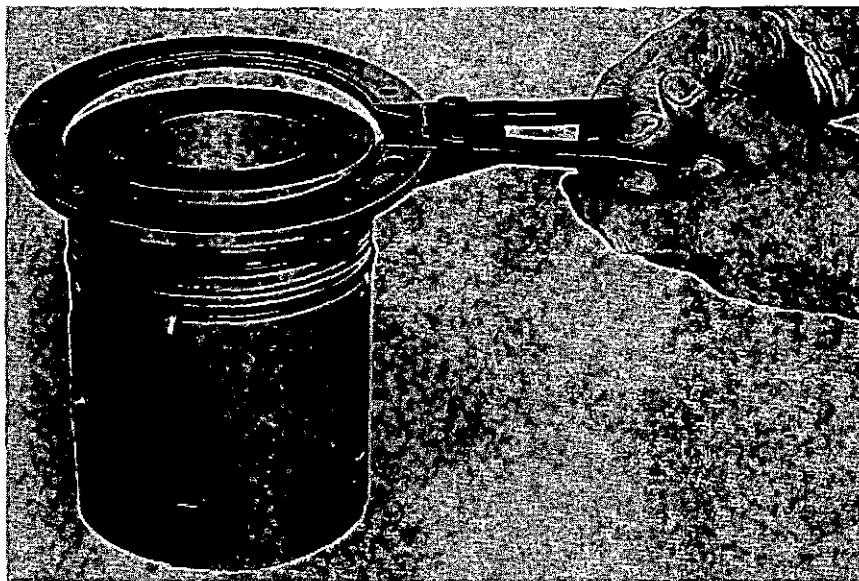

Fig. 4 Using piston ring tools GA 612 and GA 617

T720055

Printed in Great Britain

INSPECTION

Pistons and rings

De-carbonise the piston, preferably by soaking in a proprietary solvent such as "Ardrox 691".

Inspect the piston for scores and wear, and ensure that ring grooves are not worn beyond limits, checking if necessary with new rings.

Crack-test the gudgeon pin and check its fit in the piston. It should be a hand push-fit at 20 deg.C (68 deg.F).

Inspect the piston rings for scores, wear and signs of leakage. Discard the top ring if the molybdenum inlay has large pores or voids or is breaking up, comparing the surface if necessary with that of a new ring. Inspect the spring behind the oil control ring for wear. Should this spring be unserviceable the ring and spring must be renewed together. A spring giving a radial pressure of 150 lbf./sq. inch is identified, when new, by a yellow paint marking.

Check the gap of each ring in a new liner or in an unworn portion of its own cylinder. Discard any ring having a gap in excess of limits.

Notes: (a) If a new liner is fitted, the piston rings should also be renewed.

(b) When a new ring, particularly one having a chrome-plated rubbing face, is fitted in a used liner, the 'glaze' of the cylinder bore must be broken by lapping or light honing.

Connecting rods and bearings

Carry out an electro-magnetic crack test on rod, end cap and bolts. Inspect the bolts for signs of stretch and damage, and renew any found defective.

Check the small-end bearings for wear. If renewal is necessary, the pre-finished double bushes must be coated with zinc-based grease and drawn in, one from each side, flush with the rod eye faces, using tool GA 285/1M. The annular space between them forms an oil-way at least 0.1 inch (2.5mm) wide, in-line with the oil drillings. Procedure for fitting new bushes is as illustrated in fig. 6 and 7, using tool GA 285/1M (fig. 5). Refer to O.E.B. 384 for further details.

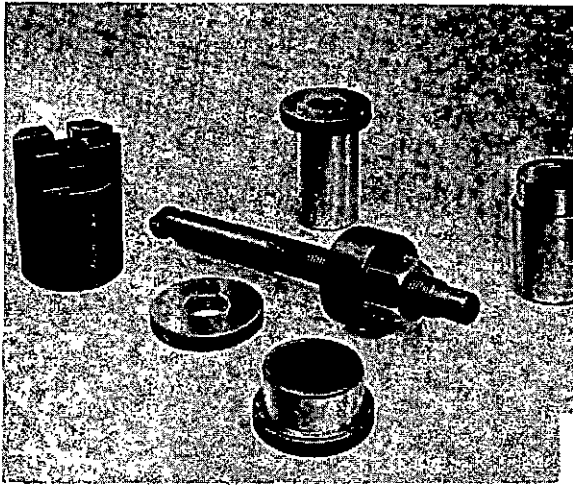

Fig. 5 Small end bush renewal tool GA 285/1M

T720077

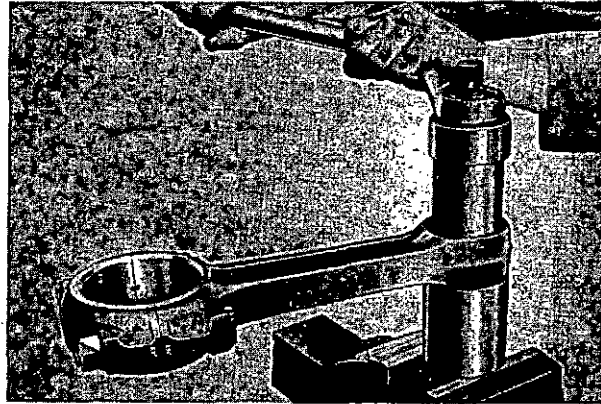

Fig. 6 Removing small end bush

T1744

Check alignment of big and small ends in two planes. *Do not* attempt to correct a bent or twisted rod.

Carefully inspect the big-end bearings for cracks, scores, wear and embedded foreign matter. Renew them if there is the slightest doubt that they will complete a full period of service. Ensure that replacement bearings are of the correct type, i.e. that they have a circumferential oil groove in the bore.

SPECIAL TOOLS

- | | |
|-----------|--------------------------------------|
| GA 285/M1 | Tool, renewing double small-end bush |
| GA 612 | Pliers, piston ring |
| GA 617 | Locating ring for GA 612 |

ASSEMBLING

Fit the piston rings, using pliers GA 612 and locating ring GA 617 (fig. 4). Ensure that non reversible rings are the right way up, and that the correct backing spring is fitted behind the oil control ring, as previously described.

Oil the small-end bush, heat the piston by immersion in hot water and assemble the piston to the connecting rod so that the FRONT marking on the piston crown and the identification stampings on the big-end are in the relationship shown by the arrows in fig. 3.

Fit the circlips, ensuring that they are properly seated by rotating them in their grooves.

See Section 3 for details concerning fitting of the assembly to the engine and checking the piston height. Note that the piston and rod assembly is fitted to the engine with the connecting rod correlation marks *away from* the camshaft, i.e. on the left-hand side of the engine, viewed from the rear.

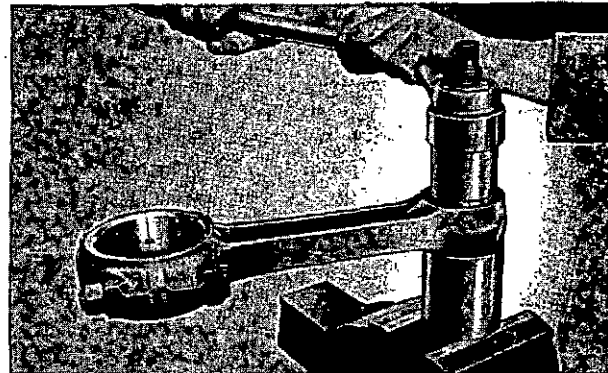

Fig. 7 Fitting small end bush

T1745

Printed in Great Britain

FITS AND CLEARANCES

PISTONS AND RINGS

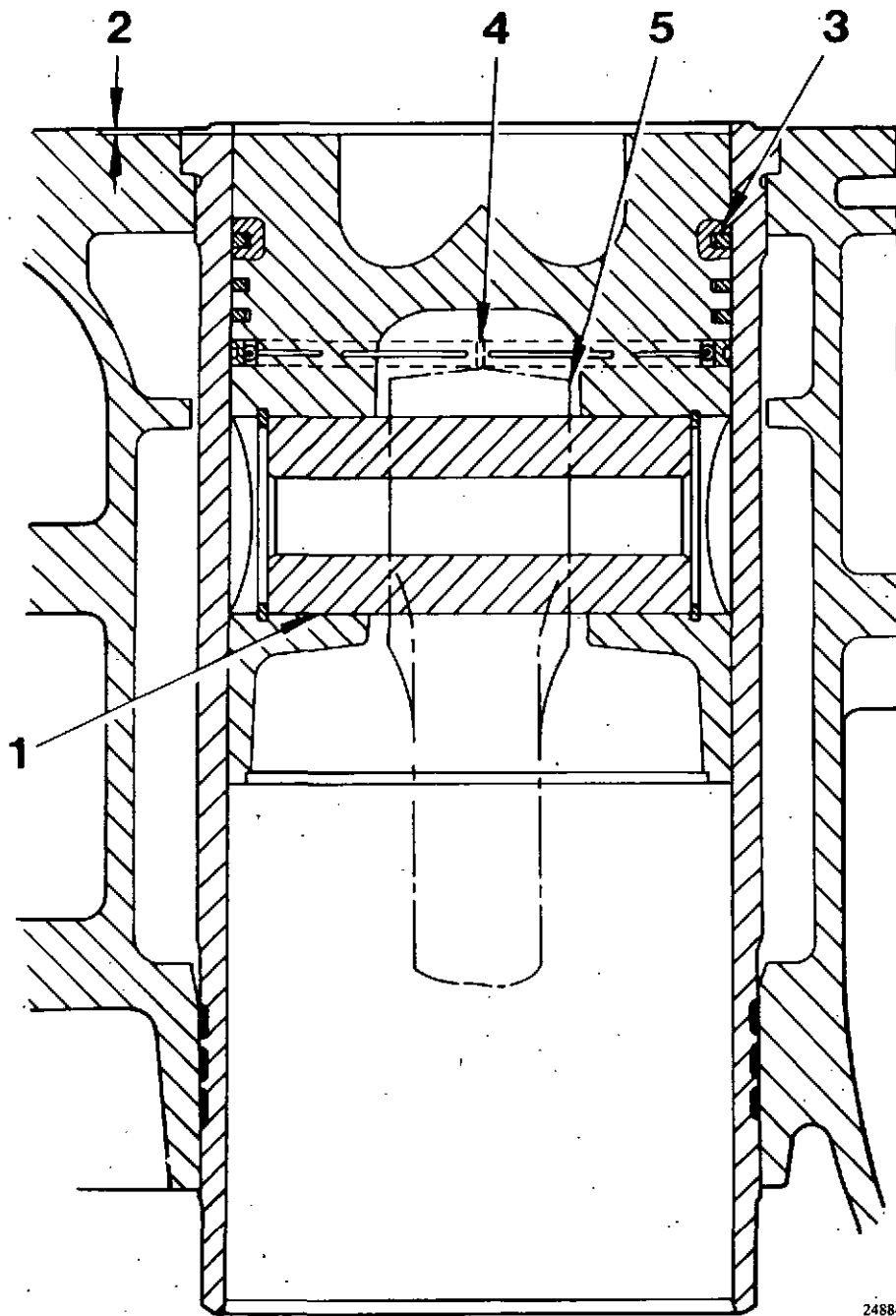

ROLLS-ROYCE DIESELS

Printed in Great Britain

No. ON DIAG.	DESCRIPTION	DIMENSIONS NEW		PERMISSIBLE WORN DIMENSIONS		CLEARANCE NEW		PERMISSIBLE WORN CLEARANCE		REMARKS	
		in.	mm.	in.	mm.	in.	mm.	in.	mm.		
1	GUDGEON PIN IN PISTON Piston — bore Gudgeon pin — diameter	2.000 to	50.800 to							To be a hand push fit at 20 deg. C (68 deg. F)	
		2.0002	50.806								
2	PISTON CROWN CLEARANCE AT T.D.C. Crown of piston below crankcase top face	2.000 to	50.800 to			0.012 to	0.30 to			Maintain clearance by machining piston crown as necessary	
		2.0002	50.806			0.015	0.38				
3	PISTON RINGS Side clearance in groove										
		Top ring					0.003 to	0.08 to	0.010	0.25	Ring OE 46334
		2nd ring					0.005	0.13	0.006	0.15	Ring OE 40750
		3rd ring (4-ring piston)					0.0035	0.09	0.006	0.15	Ring OE 42524
		Oil control ring					0.002 to	0.05 to	0.006	0.15	Ring OE 39127
							0.004	0.10	0.006	0.15	
4	Ring gap in new liner										
		Top ring					0.026 to	0.66 to	0.060	1.52	Ring OE 46334
		2nd ring					0.034	0.86	0.060	1.52	Ring OE 40750
		3rd ring (4-ring piston)					0.017 to	0.43 to	0.060	1.52	Ring OE 42524
		Oil control ring					0.027	0.68	0.040	1.01	Ring OE 39127
							0.017 to	0.43 to	0.040	1.01	
5	CONNECTING ROD IN PISTON Side clearance										
						0.150 to	3.81 to				
						0.165	4.19				



Printed in Great Britain

FITS AND CLEARANCES

CONNECTING RODS

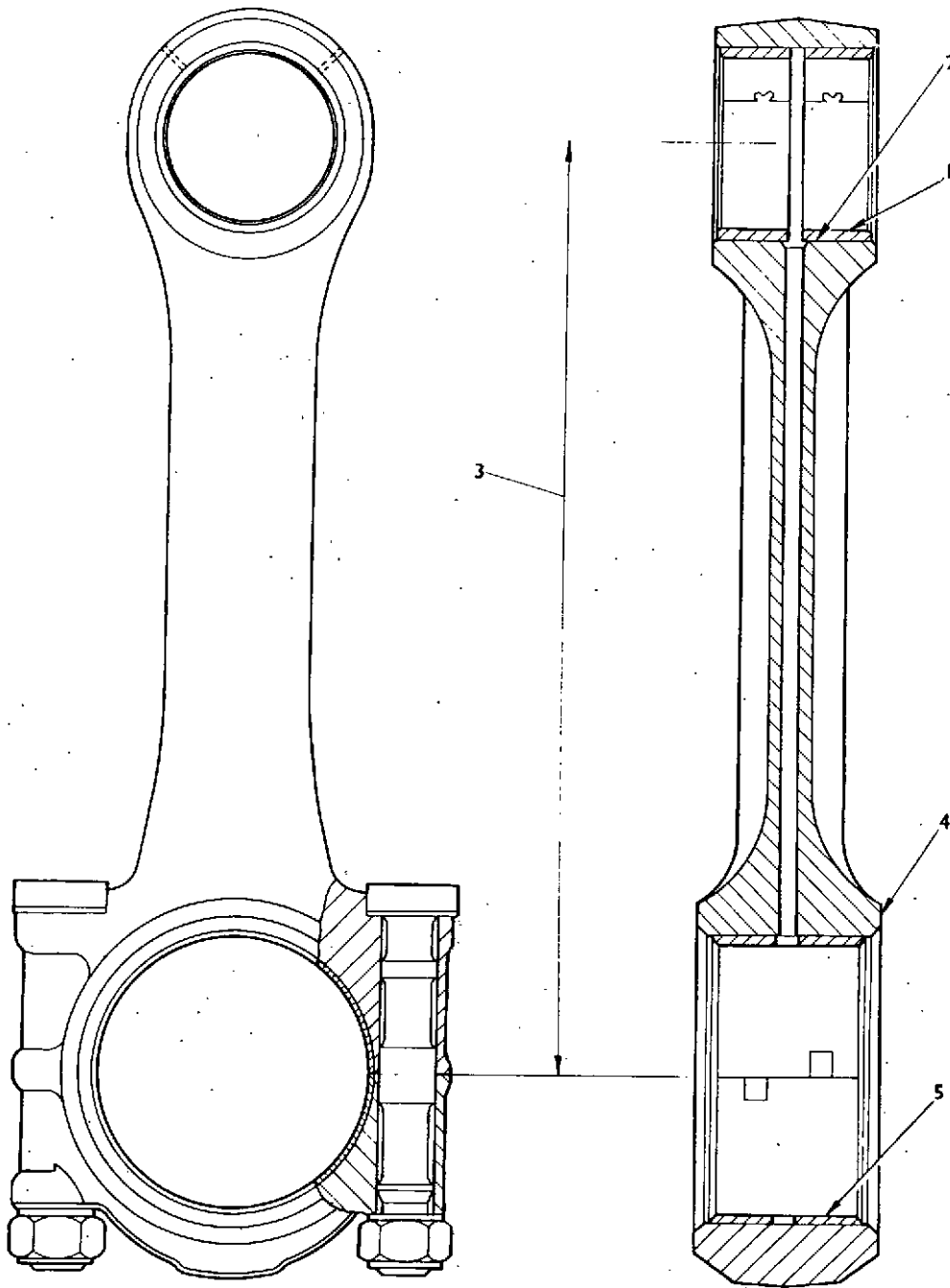

24848 A

No. ON DIAG.	DESCRIPTION	DIMENSIONS NEW		PERMISSIBLE WORN DIMENSIONS		CLEARANCE NEW		PERMISSIBLE WORN CLEARANCE		REMARKS
		in.	mm.	in.	mm.	in.	mm.	in.	mm.	
1	SMALL-END Gudgeon pin in bush Bush — bore Gudgeon pin — diameter	2.0015 to 2.002 2.000 to 2.0002	50.84 to 50.85 50.80 to 50.81			0.0012 to 0.002	0.032 to 0.051	0.0025	0.063	
2	Bush in small-end Small-end — bore Bush — diameter	2.250 to 2.2505 2.252 to 2.2535	57.150 to 57.163 57.200 to 57.239			Interference 0.0035 to 0.0015 to Interference	0.089 to 0.038			
3	ERRORS IN ALIGNMENT Errors in alignment between big and small ends per inch of mandrel Parallelism									
4	BIG END End float					0.003 to 0.008	0.08 to 0.20	0.001	0.025	
5	Running clearance					0.0025 to 0.004	0.06 to 0.10	0.012	0.30	



SECTION 8 — CYLINDER HEADS AND VALVE GEAR

DESCRIPTION

All 'C-RH' engines have two identical cast-iron cylinder heads, each secured to the crankcase top face by 22 setbolts and one drilled stud by which pressure oil is conveyed to the valve rocker gear.

Each cylinder is served by one inlet and one exhaust valve, operating in renewable cast-iron guides in the cylinder head and actuated by rocker arms and pushrods from a low-mounted camshaft. On engines assembled before Build Line number 63037 both inlet and exhaust valves are Stellite-faced with chrome-flashed stems and a face angle of 30 degrees. The exhaust valve stem is sodium-filled and Stellite-tipped; the inlet valve has a solid stem and flame-hardened tip.

Engines after Build Line number 63037 are fitted with exhaust valves (Part No. OE 47586) in Nimonic material and have solid stems; inlet valves are the same for all engines.

Both valves have double springs, retained by conventional split collets with a rubber sealing ring. A valve rotator is fitted beneath the exhaust valve springs and a distance piece of equivalent thickness beneath the inlet valve springs. When new, the springs are identified by a red paint stripe.

The upper end of each exhaust valve guide is machined to carry an oil seal, which provides more effective control of valve stem lubrication.

Renewable valve seat inserts of chrome-iron are shrunk into the cylinder head and a swirl crescent is machined in the cylinder head flame face, adjacent to each inlet valve seat.

Rolled-in exhaust valve inserts were introduced from Build Line No. 60951 onwards.

The valve rocker assembly is carried on pedestal brackets bolted to platforms within the head casting. It is lubricated from the main oil system under reduced pressure due to restrictor drillings in the oilway studs (Section 3 Fig. 11). Oil from the gallery in the tappet chest passes upwards through drillings in the crankcase to the two oilway studs, emerges from the restrictor drillings into the annular space between each stud and the cylinder head, and then flows through a cross-drilling to the centre rocker pedestal, where it enters the hollow rocker shaft. Each rocker arm is drilled to supply oil from its pivot bearing to the valve stem tip and pushrod cup.

Injectors are carried in renewable sleeves rolled into the cylinder head. No joint washer is fitted between injector and sleeve seating, the seating face being re-cut as necessary when injectors are changed.

VALVE SPRING RENEWAL (INSTALLED HEAD)

If necessary, valve springs and rotators may be renewed without removing a cylinder head, as follows:

1. Remove the appropriate rocker cover and turn the engine forward until the inlet valve of the cylinder concerned *just* commences to open. The piston will then be near TDC.
2. Slacken the tappet screws of this cylinder; then remove the rocker assembly.
3. Screw tool GA.25 into an adjacent bolt hole (fig. 1). Ensuring that no components can fall down the pushrod holes, compress the springs and extract the collets. Release the springs and remove the retainer, and rubber 'O' ring. Withdraw the springs and fit new valve stem seals.

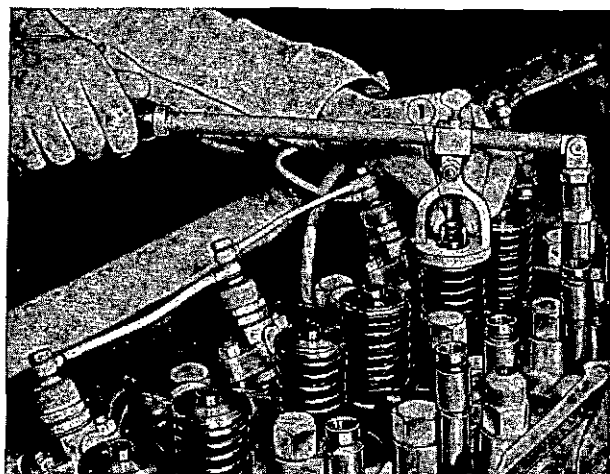

1 SPLIT COLLET

T51125

Fig. 1 Valve spring compressing tool

4. Assemble the springs and retainer, compress them and slide a new 'O' ring over the valve stem. Fit the collets and release the springs; check that the 'O' ring is correctly positioned.
5. Refit the rocker assembly, tightening the pedestal setbolts evenly to 30 lbf.ft. (40 Nm).
6. Reset the tappet clearances of all valves in the head and refit the rocker cover.

DISMANTLING AND CLEANING

To protect the flame face, stand the head on suitable wood packing. On each valve in turn, compress the springs using tool GA.25 (fig. 1) and remove the collets, spring retainer, springs and rotator or distance piece. Withdraw the valves and keep each assembly together, identified with their position in the engine.

Decarbonise the head and valves by soaking in a proprietary solvent such as 'Ardrox 691'.

CAUTION: Do not use solvent on valve springs, as this may damage their surface finish.

Finally, wash all components in paraffin, paying particular attention to oilways, and dry off with compressed air.

CYLINDER HEAD CASTING

Fit locally-made blanks to the coolant apertures and carry out a pressure test at 30 lbf./sq. inch (210 kN/sq.m) with the head immersed in water at 60 deg. C (140 deg. F). Note any leaks from cracks, core plugs or injector sleeves.

Inspect the flame face for fretting or other damage. If necessary it may be reclaimed by surface grinding to a maximum of three stages, each of 0.005 inch (0.13 mm.). See S.R.S. 6 for details.

VALVE GUIDES

Check the fit of each valve in its guide and, if the clearance exceeds the limit in the Schedule at the end of this Section, retest using a new valve.

If the clearance is still excessive renew the guide, using Kit GA.698 as follows.

Note: Replacement exhaust guides should be of the modified type which carry a valve stem seal OE.45920 on the upper end. If necessary, earlier guides held as spares may be machined to the dimensions shown in fig. 2.

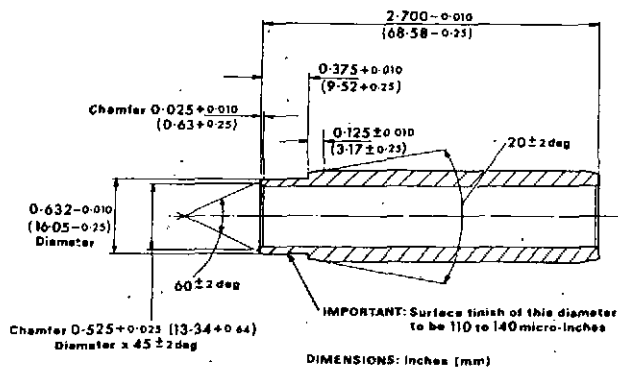

24873

Fig. 2 Modifying exhaust guide for seal

Working from the flame face, drive out the old guide using drift GA.462. Prepare the new guide by freezing in liquid air or, if this is not available, by coating it with graphited machine oil. Using tool GA.640, press the new guide into position until the tool contacts the flame face; this ensures the correct protrusion above the top face as shown in fig. 3. Inlet guides and unmodified exhaust guides are symmetrical and may be inserted either end first; modified exhaust guides must be fitted by inserting the machined end.

Using reamer GA.474, operated by hand, finish the guide bore and check with plug gauge GG.1. Finally, recut the valve seat at 30 degrees.

VALVE STEM SEALS

As mentioned earlier under 'DESCRIPTION' these are now fitted to the *exhaust* valve guides to control valve stem lubrication, the guides being modified to carry the seals. It should be noted that the valve rotator cannot be removed or fitted when the seal is in position. To remove a seal, lever it carefully upwards; it cannot be re-used and must be discarded. To fit a new seal, assemble it to tool GA.718, insert the tool into the guide (fig. 17) and carefully tap the seal into place until it reaches the shoulder on the guide. Check that the seal is not cracked or distorted and, when fitting the valve, ensure that its stem is oiled.

VALVE SEAT INSERTS

Examine all inserts for pitting, cracks and valve bedding. The seat face may be restored by cutting or grinding at 30 degrees, removing the minimum amount of metal necessary.

For this purpose the cutting tool GA.607 is recommended and is supplied with full instructions for use. Alternatively, a proprietary grinding machine may be used.

After reconditioning the valve and its seat, fit the valve and measure the clearance of the valve head below the flame face of the cylinder head. Limits are given in the Schedule at the end of this Section. If clearance is beyond the limit, retest using a new valve. Should this not bring the clearance within limits, the insert must be renewed.

Printed in Great Britain

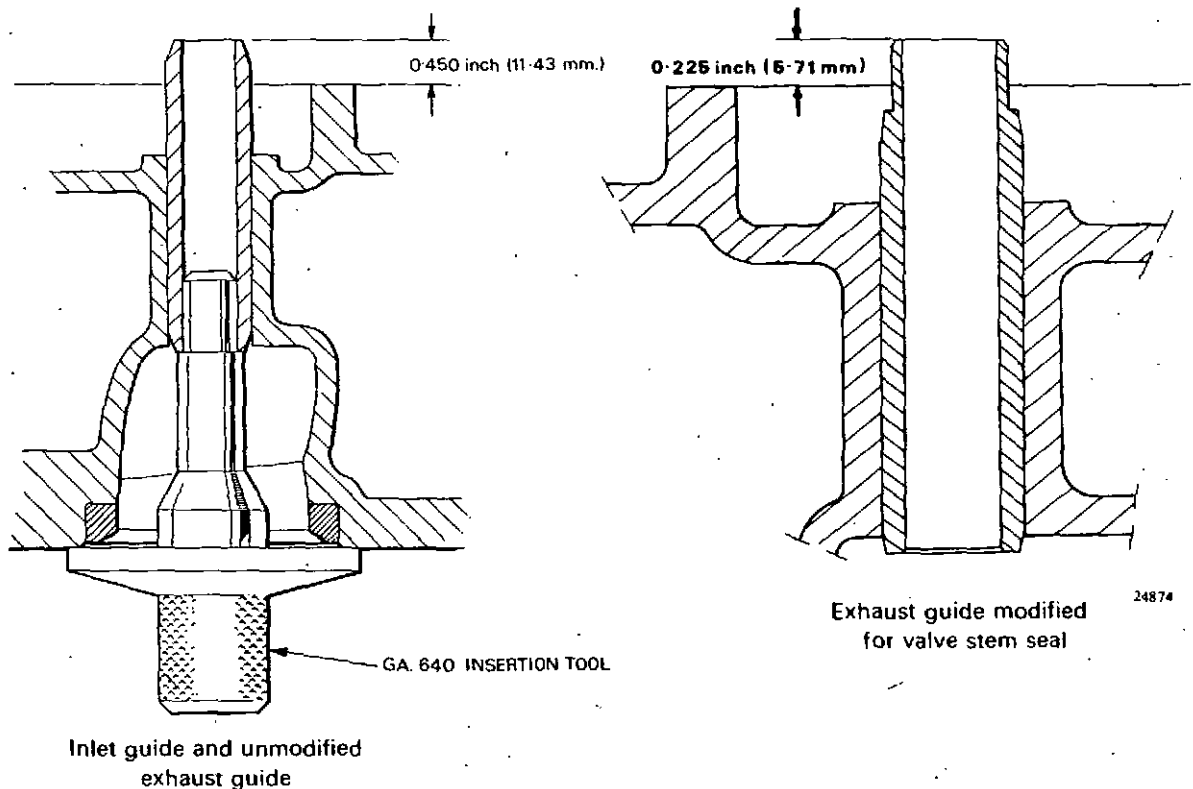

Fig. 3 Position of valve guides

Removing an insert

Engines prior to Build No. 60951

The recommended method is to machine two $\frac{3}{8}$ -inch (9.5 mm) holes close together in the insert weakening it so that it may be fractured and withdrawn. For this purpose a cutter assembly GA.691 and its guide GA.690 are available (fig. 4). The guide has two shrunk-in bushes spaced for use with 2.44-inch (62 mm) diameter and 2.289-inch (58.1 mm) diameter inserts respectively; the size is stamped on each bush. Ensure that the correct size is used when proceeding with this operation.

Engines from Build No. 60951 onwards

(Rolled-in inserts)

Use GA 804 cutter with GA 805 arbor, turning by hand in a clockwise direction, to remove the rolled-over material retaining the six exhaust valve inserts.

When this exercise has been completed proceed with the directions given for the earlier engines.

GA 691 cutter is adjustable for depth relative to its stop face, and is locked in position by two Allen screws.

CAUTION: It is essential to set the cutter so that there is no possibility of machining through the insert and into the cylinder head; a safety margin of at least 0.020 inch (0.5 mm) should be allowed.

Calculating the setting of the cutter edge beneath its stop face involves adding together the following three dimensions and subtracting the safety margin:

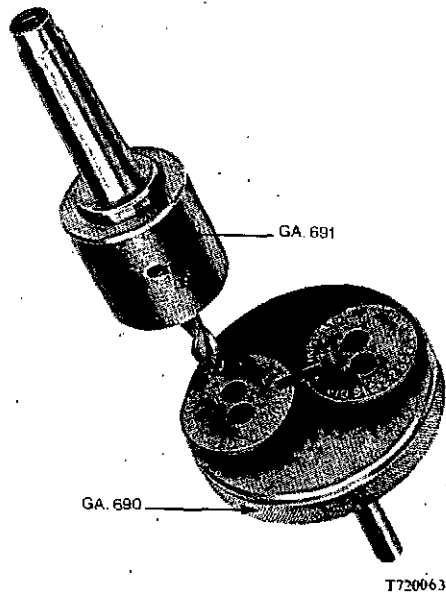

Fig. 4 Valve seat removal tools

(i) Thickness of cutter guide bush in tool GA.690. This is 1.0 inch (25.4 mm.).

(ii) Depth of insert beneath flame face. Due to possible reclamation of flame face, and differences in insert thickness, this dimension may vary and must be measured by depth gauge.

(iii) Thickness of insert. Minimum dimensions are:
Inlet: 0.308 inch (7.8 mm.)

Exhaust: 0.243 inch (6.17 mm.)

Note: The exhaust insert thickness quoted here is that of OE.43479, which may be identified by a V groove concentric with the valve seat. Its predecessor OE.42294 was 0.020 inch (0.5 mm.) thicker and had no groove.

Example calculation for cutter setting:

	inches	(mm.)
(i) Cutter guide bush.....	1.000	(25.40)
(ii) Insert below flame face*	0.129	(3.28)
(iii) Thickness, inlet insert.....	0.308	(7.82)
	-----	-----
	1.437	(36.50)
Subtract safety margin.....	0.020	(0.50)
	-----	-----
Set cutter edge to.....	1.417	(36.00)

* Measured for each insert

To remove an insert, assemble cutter guide GA.690 to it and clamp both GA.690 and cylinder head securely to the machine table. Set the cutter of tool GA.691 to the required depth, as explained, and lock it by means of the two Allen screws. Using a cutting speed of 350 to 400 rpm, and fine feed with ample cutting oil, machine two holes in the insert, locating the guide by a short length of $\frac{3}{8}$ -inch (9.5 mm.) rod in the first hole whilst machining the second. Remove the tools from the cylinder head, insert a length of $\frac{3}{8}$ -inch (9.5 mm.) rod in one of the holes, fracture the insert and remove it. Clean the counterbore and inspect it for burrs and damage.

Fitting a new insert (non rolled-in type)

Replacement inserts are available either to standard diameter or 0.002 inch (0.05 mm.) oversize. If an oversize insert is to be fitted the counterbore in the cylinder head must be machined to maintain the interference fit specified in the Schedule at the end of this Section.

The inserting tool GA.682 (fig. 5) consists of two threaded drawing-in assemblies for inlet and exhaust inserts respectively. A sleeve GA.142 is used with

each assembly if no valve guides are fitted. When fitting an exhaust insert or an unmasked inlet insert, either assembly is used by itself. If a masked insert is to be fitted (normally-aspirated engines) the masking must be positioned as shown in fig. 6; this is achieved by using both assemblies of tool GA.682 together, as shown in fig. 5. The exhaust insert must be fully home, with its inserting assembly left in position; the inlet insert is then fitted to its assembly tool so that the masking is located in the cutaway, and is drawn into place, which is only possible if the flats machined on the assembly tools are together as illustrated, thus ensuring correct positioning of the masking.

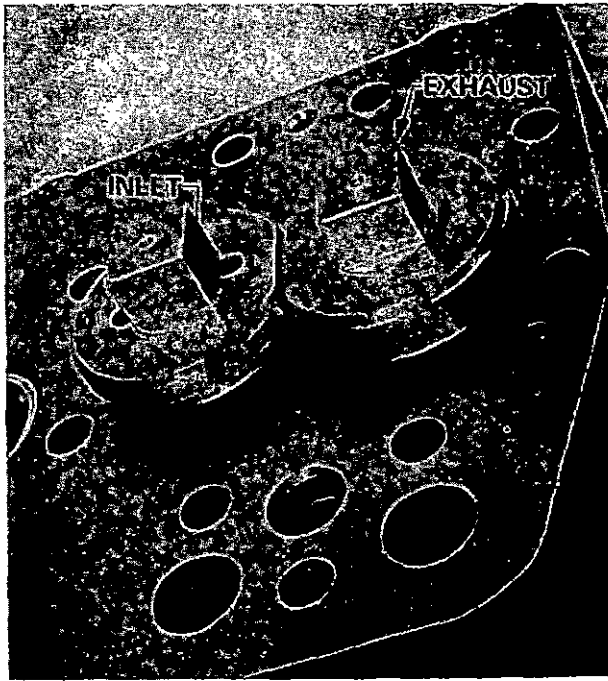

Fig. 5 Valve seat inserting tools, as used for masked insert

For preference, an insert should be frozen in liquid air immediately before insertion. If this is not available the cylinder head must be heated in boiling water for half-an-hour and the insert drawn into place as quickly as possible. Check by feeler gauge that the insert is fully home. If applicable, fit the valve guide as previously described. Finally, cut or grind the valve seat at 30 degrees, assemble the valve and measure the clearance between valve head and flame face.

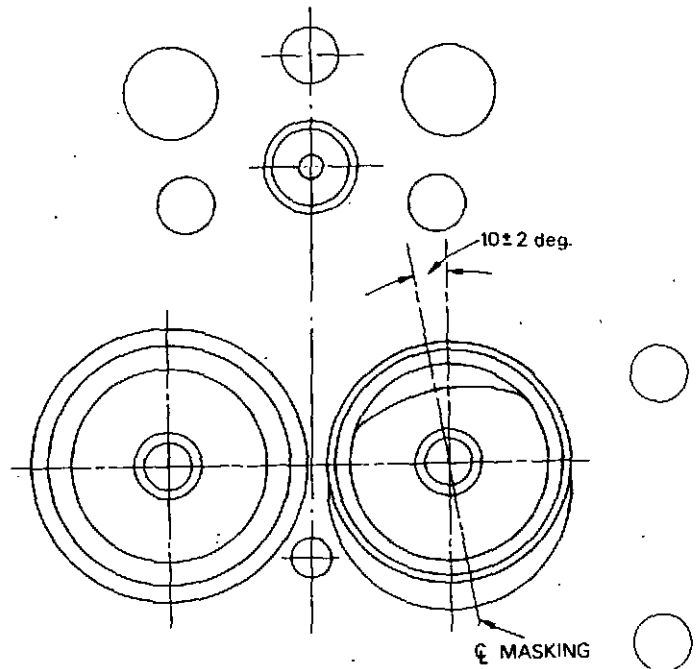

Fig. 6 Alignment of masked inlet seat insert

Fitting a new insert (rolled-in type)

Replacements for this type of insert are available either to standard diameter (OE 46959) or 0.002 inch oversize (OE 46960) and have a chamfer on each outer edge.

To fit a new insert as a replacement for one of similar type proceed as follows:

1. Assemble the new insert in the cylinder head in the manner described previously for the non rolled-in type.
- * 2. Position GA 803 'rolling tool' into the valve guide. Whilst maintaining steady downwards pressure, turn clockwise at a speed of 100 rpm until the stop on the tool is reached. Lubricate between the rollers and cylinder head surface during this operation with S.A.E. 30 grade oil.

To modify a cylinder head and enable a rolled-in type insert to be fitted as a replacement for a non rolled-in type proceed as follows:

1. Fit the new insert as in (1) above.
2. Locate GA 802 'counter-bore cutter' in the valve guide and whilst applying downward pressure

turn slowly in a clockwise direction until the cutting ceases. This will provide a suitable surface for the rolling-in process.

3. Proceed with the rolling-in process as in (2)* previous.

VALVES

After thorough cleaning, use a powerful magnifying glass to inspect the valves for cracks, pitting or other damage to the heads. Inspect the stems, collet grooves and tips for wear. On apparently serviceable or reclaimable valves, test the heads for cracks using a dye-penetrant process such as 'Ardrox 996' which is obtainable, with instructions for use, from Ardrox Limited, Commerce Road, Brentford, Middlesex.

Check heads of exhaust valves for 'dishing' by straightedge and feeler gauge. Scrap the valve if the clearance under the straightedge exceeds 0.015 inch (0.38 mm.).

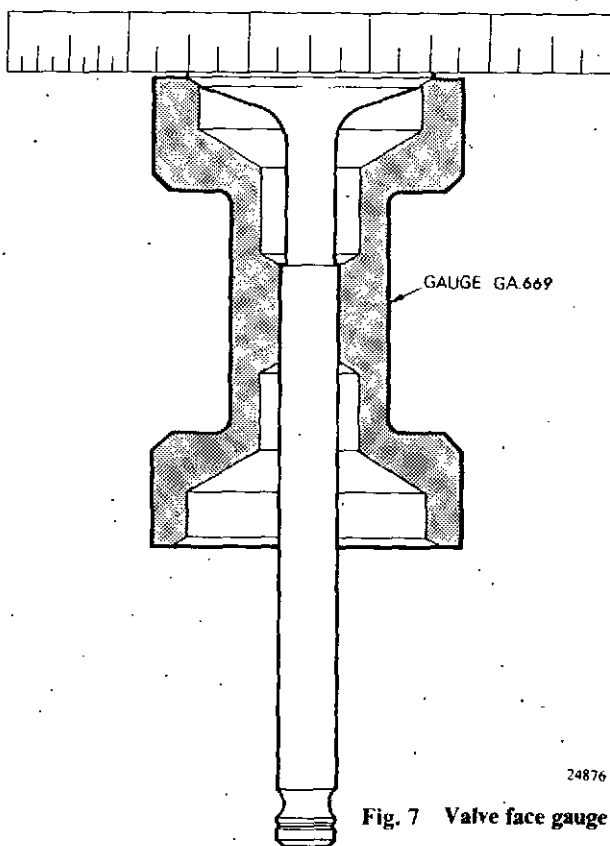

Fig. 7 Valve face gauge

Reclaim pitted or worn valve faces by grinding at 30 degrees, removing the minimum amount of material necessary to restore the face. Use gauge GA.669 which accepts an exhaust valve at one end and an inlet valve at the other, (fig. 7) to check whether sufficient material remains. Scrap any valve if its head comes below the top face of the gauge, as measured by the straight-edge.

WARNING: Sodium filled exhaust valves (fig. 8) must be broken down before being sent as scrap. This is done by dry-grinding the stem at mid-point until the sodium is just exposed, and immediately immersing the valve in a tank containing at least 20 gallons (90 litres) of water. As the sodium dissolves, hydrogen is given off and the water becomes a caustic solution: adequate precautions against fire and personal injury are therefore necessary.

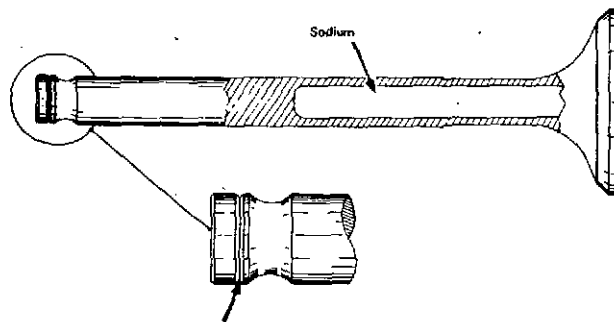

Fig. 8 Identification groove, sodium-filled valve

Exhaust valves in Nimonic material have the part number OE.47586 stamped close to the collet recess.

Identification by stamping or pop-marking is NOT recommended, since these indentations can form the starting-place for cracks which may eventually cause valve head failure.

Assemble each valve to its guide and check for seating, lapping-in if necessary. Finally, measure the distance of the valve head below the flame face of the cylinder head. This must be within the limits given under 'Fits and Clearances' at the end of this Section. Insufficient clearance is rectified by recutting the valve seat. Excessive clearance may be rectified by fitting a new valve or, if this is inadequate, by renewing the insert.

VALVE ROTATORS (ROTOCOIL)

Inspect for cracks and other damage, and check that the inner and outer components will rotate freely, relative to one another. If the wear pattern on the valve stem tip indicates that the valve has not rotated, change the rotator even though superficially it may appear serviceable. Note that when valve stem seals are fitted they must be renewed if rotators are removed.

INJECTOR SLEEVES

Engines prior to Build Line No. 60951

Recondition the sleeves using kit GA.702, which consists of reamer GA.304 for cleaning the nozzle bore and cutter GA.299 for refacing the nozzle seating (fig. 10). Do not remove more metal than is necessary to restore the seating face. The maximum depth of the seating face, measured from the flange face on the cylinder head, is 3.54 inches (90 mm).

A sleeve which has been recut beyond the limit, or has been damaged, or is leaking from the rolled joint and cannot be rectified by use of the roller expanders GA.688 and GA.689, may be renewed as described below. For this purpose a service sleeve OE 42770 and tool kit GA.700 are available.

1. Using the tap GA.671, cut a thread in the sleeve bore (fig. 11) to a minimum depth of one inch (25 mm.).
2. Screw the extractor GA.672 into this thread and withdraw the sleeve (fig. 12). Considerable effort is required to shear the rolled-out diameter of the sleeve.
3. Clean out the bore and groove in the cylinder head. Insert the service sleeve OE 42770 and press it in by hand as far as possible. Locate tool GA.306 in the sleeve bore and also on the injector studs, securing it by the two nuts. Tighten the centre screw of the tool to press the sleeve fully home (fig. 13). The top of the sleeve will then be slightly below the cylinder head face.
4. Fully retract the tapered spindle of the lower roller expander GA.688, grease the rollers and insert the assembly into the sleeve bore. Rotate the spindle clockwise until the lower portion of the sleeve is sealed in the cylinder head bore.

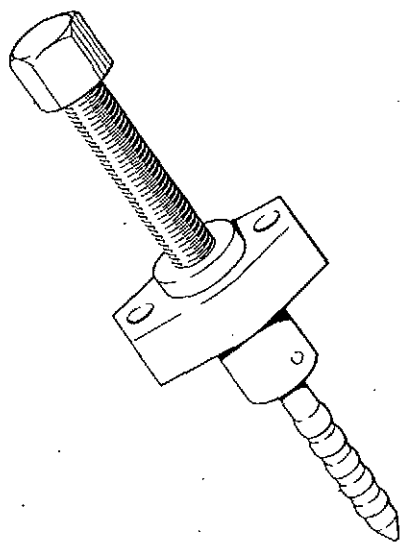
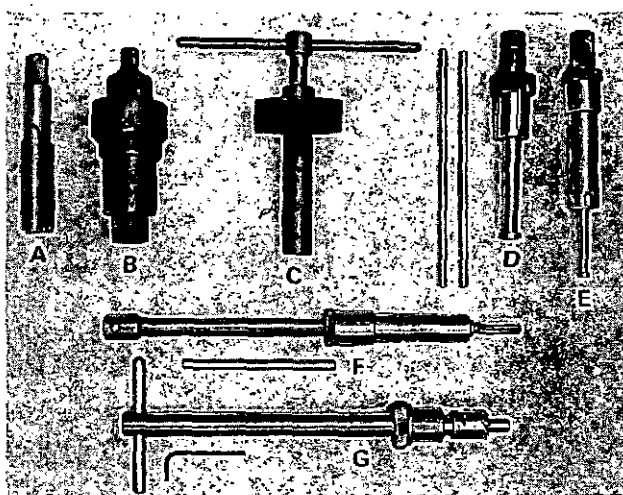

Fig. 9 Ballising Tool 24886

VALVE SPRINGS

Check each one for wear, corrosion and distortion. Measure the free length and the length under load, as applicable, to the instructions given in 'Fits and Clearances' at the end of this Section. Scrap any spring which is not entirely satisfactory.



- | | |
|----------------------|-----------------------|
| A. Tap for extractor | E. Expander, lower |
| B. Extractor | F. Nozzle bore reamer |
| C. Inserting tool | G. Seating cutter |
| D. Expander, upper | |

Fig. 10 Injector sleeve tools

Printed in Great Britain

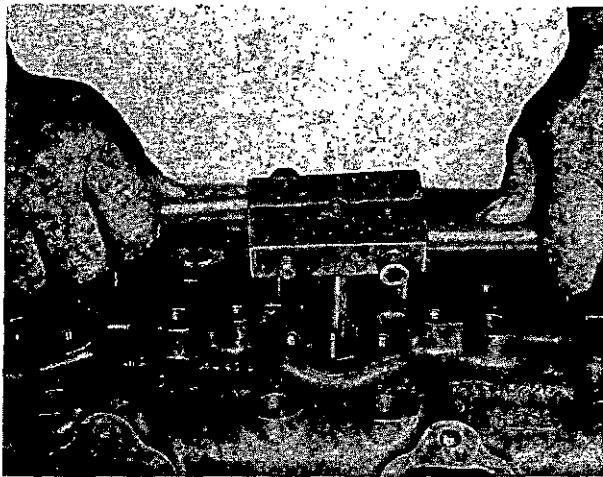

Fig. 11 Tapping the old sleeve

T720066

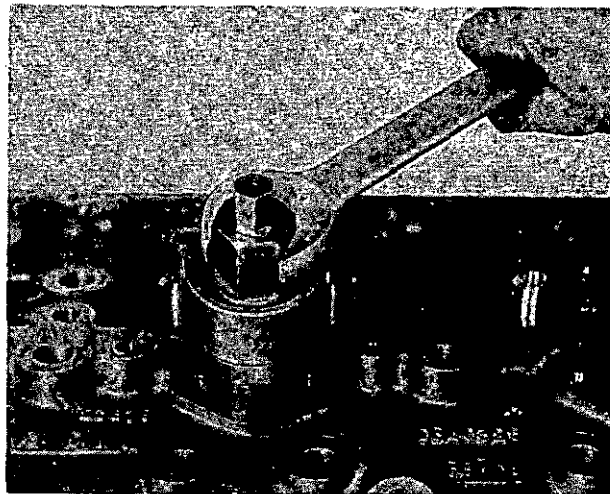

Fig. 12 Extracting the old sleeve

T720067

Disengage the tool by turning the spindle anti-clockwise. Repeat for the top portion of the sleeve, using the upper roller expander GA.689 (fig. 14).

5. Using the reamer GA.304, ream the nozzle bore to 0.378 inch (9.6mm.) diameter.
6. Reface the lower seating, using cutter GA.299 (fig. 15) well lubricated with cutting oil. Remove the minimum amount of metal required to obtain full seating, and take care to avoid 'chatter'.
7. Clean thoroughly, and if possible carry out a pressure test at 301bf./sq. inch (210kN/sq.m) air pressure with the cylinder head submerged in water at 60 deg.C (140 deg.F.).

Engines from Build Line No. 60951 onwards.

Cylinder heads on these engines are fitted with 'ballised' injector sleeves which may be reconditioned using the cleaning and renewal kit GA.722. The maximum permitted depth of the seating face measured from the flange face on the cylinder head, after recutting the seating, is 3.54 inches (90 mm). If this depth is exceeded, or if the sleeve is damaged or leaking, a replacement sleeve OE 47012 must be fitted as follows:

1. Tap thread in the sleeve bore, screw in the extractor and withdraw the sleeve.

2. Clean out the bore in the cylinder head and press in the service sleeve OE 47012 as far as possible by hand.
3. Smear the lower end of the 'ballising tool' GA.720/M1 (fig. 9) with grease and fit the tool in the injector sleeve, using the injector retaining setscrews. Tighten down the centre screw thus forcing the end of the spindle through the lower end of the sleeve and sealing the sleeve in the cylinder head bore.

CAUTION: If carrying out this operation with the cylinder head in position on the engine always ensure that the piston of the cylinder being worked on is at B.D.C.

4. Grease the rollers of the expander tool GA.689 and insert the assembly into the upper portion of the injector sleeve bore. Rotate the spindle clockwise until the sleeve is sealed in the cylinder head bore. Disengage the tool by turning the spindle anti-clockwise.
5. Using the reamer GA.726 ream out the nozzle bore in the injector sleeve.
6. Reface the lower seating using cutter GA.299 with pilot GA.725, well lubricated with cutting oil. Remove only the minimum of metal necessary to obtain a full seating, and take care to avoid 'chatter'.

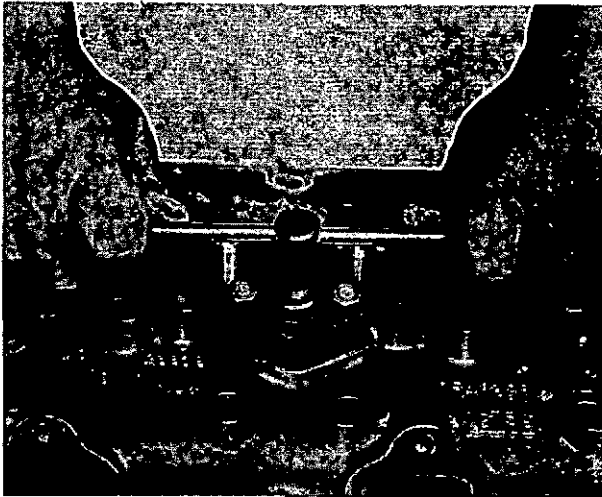

T720068

Fig. 13 Pressing in the new sleeve

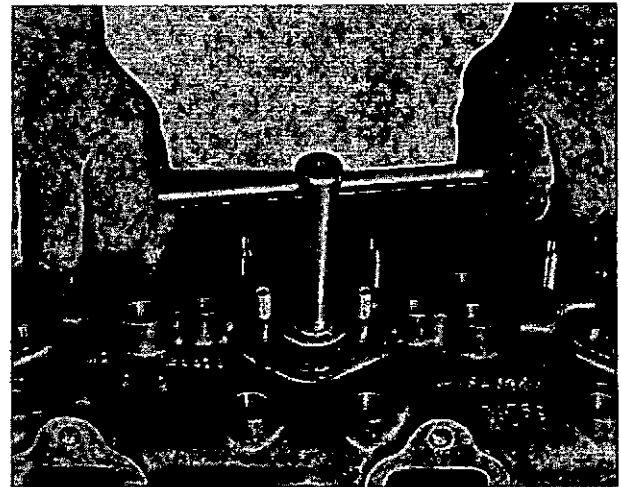

T720070

Fig. 15 Cutting injector seating

7. Clean thoroughly, and if possible carry out a pressure test at 30 lbf./sq. inch (210 kN/sq. m) air pressure with the cylinder head submerged in water at 60 deg.C (140 deg.F).

VALVE ROCKER ASSEMBLY

Remove the circlips from the rocker shaft, and the setbolt from the centre pedestal, and dismantle the assembly (fig. 16.). Unscrew the blanking plugs from the shaft. Thoroughly clean all parts, with particular attention to the oilway drillings. Refit the plugs.

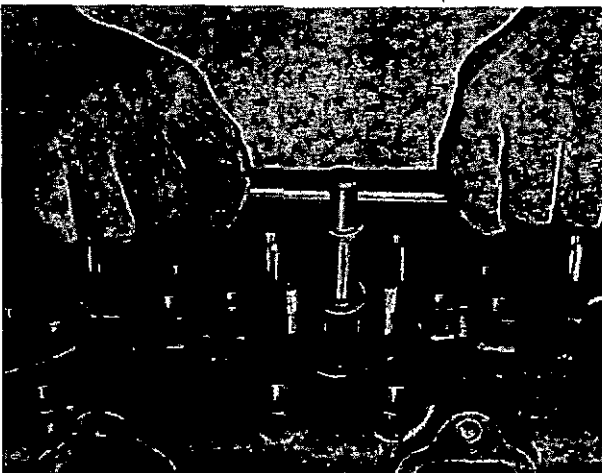

T720069

Fig. 14 Rolling in the new sleeve

Inspect all components for wear and damage. Remove any slight ridges on rocker pads by careful stoning. Renew worn rocker bushes as necessary, ensuring that the oil holes are correctly aligned. These bushes are pre-finished and do not require machining.

Reassemble the rockers, commencing by fitting the centre pedestal and engaging its locating setbolt with the recess in the rocker shaft (both arrowed, fig 16). Note that the shaft oilway drillings are then on the underside. Tighten and lock the centre pedestal setbolt and assemble the remaining components, finally securing them with new circlips. No locating setbolts are fitted to the tappings in the two outer pedestals.

PUSHRODS

Examine the hardened ends for wear and damage, and check each rod for bowing. Maximum run-out, measured over the full length of the rod, is 0.025 inch (0.63 mm.).

CORE PLUGS

These are brass cups, driven into position, and are of three sizes. The kit for renewing a plug consists of a tap for cutting a screw-thread in the inner circumference of the old plug, an extractor which engages in this thread, and a drift for inserting the new plug. After removing the old plug, clean out the centre bore and, if desired apply a thin coat of sealing compound to the new plug before driving it home.

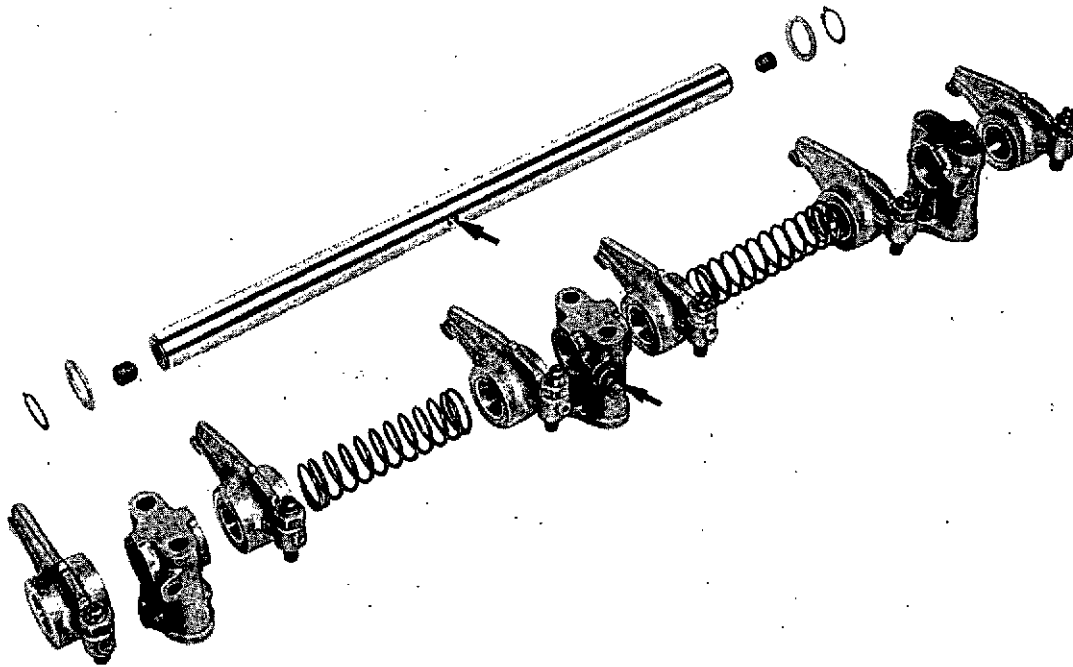

Fig. 16 Valve rocker assembly—exploded

ASSEMBLING THE VALVES

Fit a rotator to each exhaust guide and a distance piece to each inlet guide. As described under 'Valve stem seals', and illustrated in fig. 17, fit a new seal to each exhaust guide. Fit the valves, ensuring that their stems are oiled before insertion. Assemble a pair of springs and a retainer to each valve. In turn, compress the springs with tool GA.25 (fig. 1) and slide a rubber 'O' ring over the valve stem so that when the collets are fitted and the springs are released the rubber sealing ring is trapped inside the retainer.

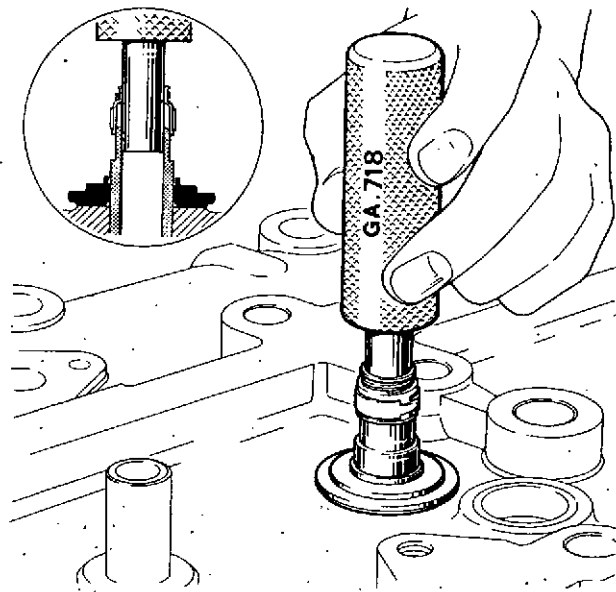

Fig. 17 Fitting seal to exhaust valve guide

24879

SPECIAL TOOLS

GA.13	Lifting attachment, cylinder head	GA.725	Pilot
GA.25	Tool, compressing valve spring	GA.726	Reamer
GA.718	Fitting tool, exhaust valve stem seal	GA.727	Tool box
GA.698	Kit, valve guide renewal, comprising:	GA.700	Kit, injector sleeve renewal, comprising:
GA.462	Extractor	GA.671	Tap, extractor thread
GA.640	Insertion tool	GA.672	Extractor
GA.474	Reamer	GA.306	Insertion tool
GG1	Plug gauge	GA.688	Expander lower
GA.699	Box	GA.689	Expander upper
		GA.701	Box
GA.607	Tool, cutting valve seats	GA.385	Kit, core plug renewal, comprising:
GA.607/1	Replacement cutter for GA.607	GA.382	Tap
GA.669	Gauge, valve face	GA.377/M1	Extractor
		GA.387	Insertion tool
			} $\frac{3}{8}$ - inch plug OE.21386
GA.691	Cutter assembly, removing valve seats	GA.383	Tap
GA.690	Guide for GA.691	GA.378/M1	Extractor
GA.682	Insertion tool, valve seats	GA.388	Insertion tool
GA.142	Sleeves (2) for GA.682, if no guides		} 1-inch plug OE.21387
*GA.702	Kit, 'low spring' injector sleeve servicing comprising:	GA.384	Tap
GA.299	Cutter, injector seating	GA.379/M1	Extractor
GA.675/M1	Holder for GA.299	GA.389	Insertion tool
GA.721	Pilot for GA.675/M1		} 1 $\frac{1}{2}$ - inch plug OE.22354
GA.304	Reamer, nozzle hole	GA.386	Box
GA.674	Holder for GA.304	GA.802	Counter bore cutter
GA.619	Allen key	GA.803	Rolling tool
GA.703	Box	GA.804	Hand cutter
GA.722	Kit, cleaning and renewal, comprising:	GA.805	Arbor (for GA.804)
GA.299	Cutter		
GA.306	Insertion tool		
GA.619	Allen key		
GA.671	Hand tap		
GA.672	Extractor		
GA.674	Reamer holder		
GA.675/M1	Cutter holder		
GA.689	Expander		
GA.720/M1	Ballising tool		

SERVICE RECLAMATION SCHEMES

SRS6 Reclaiming cylinder head flame face



Printed in Great Britain

FITS AND CLEARANCES

CYLINDER HEADS AND VALVE GEAR

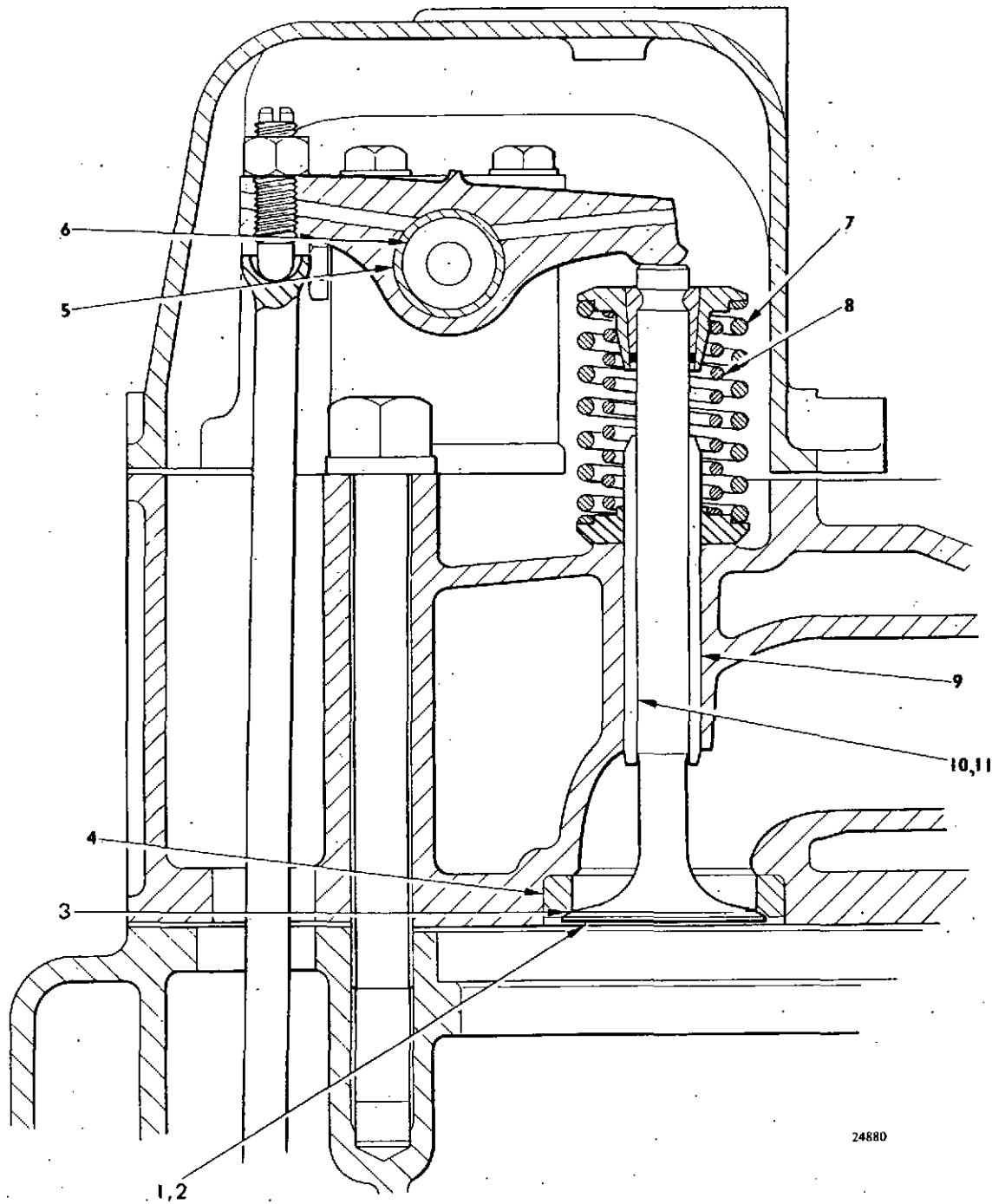

24880

No. ON DIAG.	DESCRIPTION	DIMENSIONS NEW		PERMISSIBLE WORN DIMENSIONS		CLEARANCE NEW		PERMISSIBLE WORN CLEARANCE		REMARKS
		in.	mm.	in.	mm.	in.	mm.	in.	mm.	
1	VALVE CLEARANCE BELOW FLAME FACE Normally aspirated engines Inlet Exhaust					0.025 to	0.63 to	0.054	1.37	Masked insert
						0.042 to	1.07 to	0.119	3.02	
2	Turbocharged engines Inlet Exhaust					0.025 to	0.63 to	0.054	1.37	
						0.042 to	1.07 to	0.119	3.02	
3	VALVE SEAT INSERTS Angle of valve seat									
4	Inserts in cylinder head Cylinder head—bore *Insert—diameter	30 deg.								
		2.286 to	58.07 to							
		2.287	58.09							
		2.289 to	58.14 to							
5	ROCKER GEAR Bush in rocker arm Rocker arm—bore Bush—dia.	1.0312 to	26.19 to							
		1.0317	26.21							
		1.034 to	26.26							
		1.035	26.29							
6	Rocker arm on shaft Bush—bore Shaft—dia.	0.8745 to	22.21 to							
		0.875	22.22							
		0.873 to	22.17 to							
		0.8735	22.18							

* Diameter of standard items. Inserts 0.002 in. (0.05 mm.) oversize are available and cylinder head bore must be machined to maintain correct fit.

ROLLS-ROYCE DIESELS

No. ON DIAG.	DESCRIPTION	DIMENSIONS NEW		PERMISSIBLE WORN DIMENSIONS		CLEARANCE NEW		PERMISSIBLE WORN CLEARANCE		REMARKS
		in.	mm.	in.	mm.	in.	mm.	in.	mm.	
7	VALVE SPRINGS Outer (new) Free length (nominal) Minimum length under 76 ± 4 lb. (34 ± 1.8 kg.) load	3.07	77.97							For both springs, maximum lean is 0.06 inch (1.5 mm.) when stood on either end.
		2.025	51.43	2.025	51.43					
8	Outer (used) Minimum length under 68.5 lb. (31 kg.) load Inner (new) Free length (nominal) Minimum length under 40 ± 2.5 lb. (18.1 ± 1.1 kg.) load	2.89	73.40							
		1.86	47.24	1.86	47.24					
9	VALVE GUIDES Cylinder head—bore Valve guide—dia.	0.750 to 0.7505	19.05 to 19.06							Interference 0.0005 to 0.0015
		0.751 to 0.7515	19.07 to 19.08					0.0005 to 0.0015	0.013	
10	VALVES IN GUIDES Inlet valve—dia. Valve guide—bore	0.498 to 0.4985	12.65 to 12.66							Interference 0.0015 to 0.0025
		0.500 to 0.5005	12.70 to 12.71					0.0015 to 0.0025	0.038 to 0.063	
11	Exhaust valve—dia. Valve guide—bore	0.4955 to 0.496	12.58 to 12.59							Max. bellng at lower end of bore: 0.020 in. (0.51 mm.) on diameter
		0.500 to 0.5005	12.70 to 12.71					0.004 to 0.005	0.10 to 0.13	
										Max. bellng at lower end of bore: 0.040 in. (1.02 mm.) on diameter

SECTION 9 — COOLING SYSTEM

Printed in Great Britain

DESCRIPTION

The system illustrated in fig. 1 applies to 'C-RH' engines currently in production.

Coolant leaving the radiator is drawn through an oil-to-coolant heat exchanger by a belt-driven centrifugal pump and delivered to the inlet gallery of the cylinder block through a port in the pump back-plate. After circulating around the cylinder liners the coolant passes through transfer bobbins into the cylinder heads where it flows round the valves and injectors.

On leaving the heads the coolant passes through a gallery pipe to the thermostat housing mounted above the coolant pump. If working temperature has not been reached, the thermostat valves are shut and the coolant is by-passed back to the pump for recirculation through the engine. At working temperature, the coolant passes through the thermostat to enter the bottom of the 'two-pass' radiator. The coolant then flows up and down the radiator and is cooled before returning to the engine.

The engine is fitted with a drain cock on the left-hand side of the cylinder block, forward of the flywheel housing (see Frontispiece). This cock is open when turned anti-clockwise to its full extent. On some installations a drain cock is also fitted at the rear of the heat exchanger.

COOLANT

For information on recommended coolant, refer to leaflet TSD 3085 which is carried in a pocket in the

rear cover of this Manual. Instructions for maintenance of the system in service are given in the Engine Servicing Manual, TSD 3126.

COOLANT PUMP

The coolant pump is mounted on the crankcase and is illustrated in cross-section in fig. 2. The following information concerns dismantling, inspection and assembly with reference to the item numbers on Fig. 2.

Dismantling

Remove the backplate (18) and withdraw the rotor from the shaft. It is a press fit and two $\frac{1}{8}$ inch UNF tappings are provided for use with extractor GA.7. Unscrew the setbolts securing the bearing housing (5) to the pump casing (8) and separate them. Unlock and unscrew the rotor shaft nut and remove its tabwasher and keywasher.

Press the rotor shaft (1) out of the bearing housing (5); this will bring the roller bearing inner race, the distance piece (6) and the outer seal (2) with it. Remove the circlip (3), press out the ball bearing (7) and the roller bearing outer race (4).

Inspection

Inspect the rotor shaft (1) for wear, especially at the seal rubbing areas. Clean all grease from the bearings and examine them for wear. The ball bearing controls the end float of the shaft, which should not exceed 0.005 inch (0.13 mm). Examine the rotor for erosion, corrosion and damage.

KEY TO FIG. 1—TYPICAL COOLING SYSTEM,

1. Oil-to-coolant heat exchanger
2. Coolant inlet gallery
3. Coolant outlet gallery
4. Thermostat housing
5. Coolant outlet to radiator
6. Thermostat
7. To thermostat from outlet gallery
8. Thermostat by-pass to pump
9. Pump to inlet gallery
10. To pump from heat exchanger
11. Engine drain cocks
12. Radiator drain plug

- A General view of system
B = Flow through thermostat and pump
C = Diagrammatic circuit
D = Flow through cylinder block and head, from front

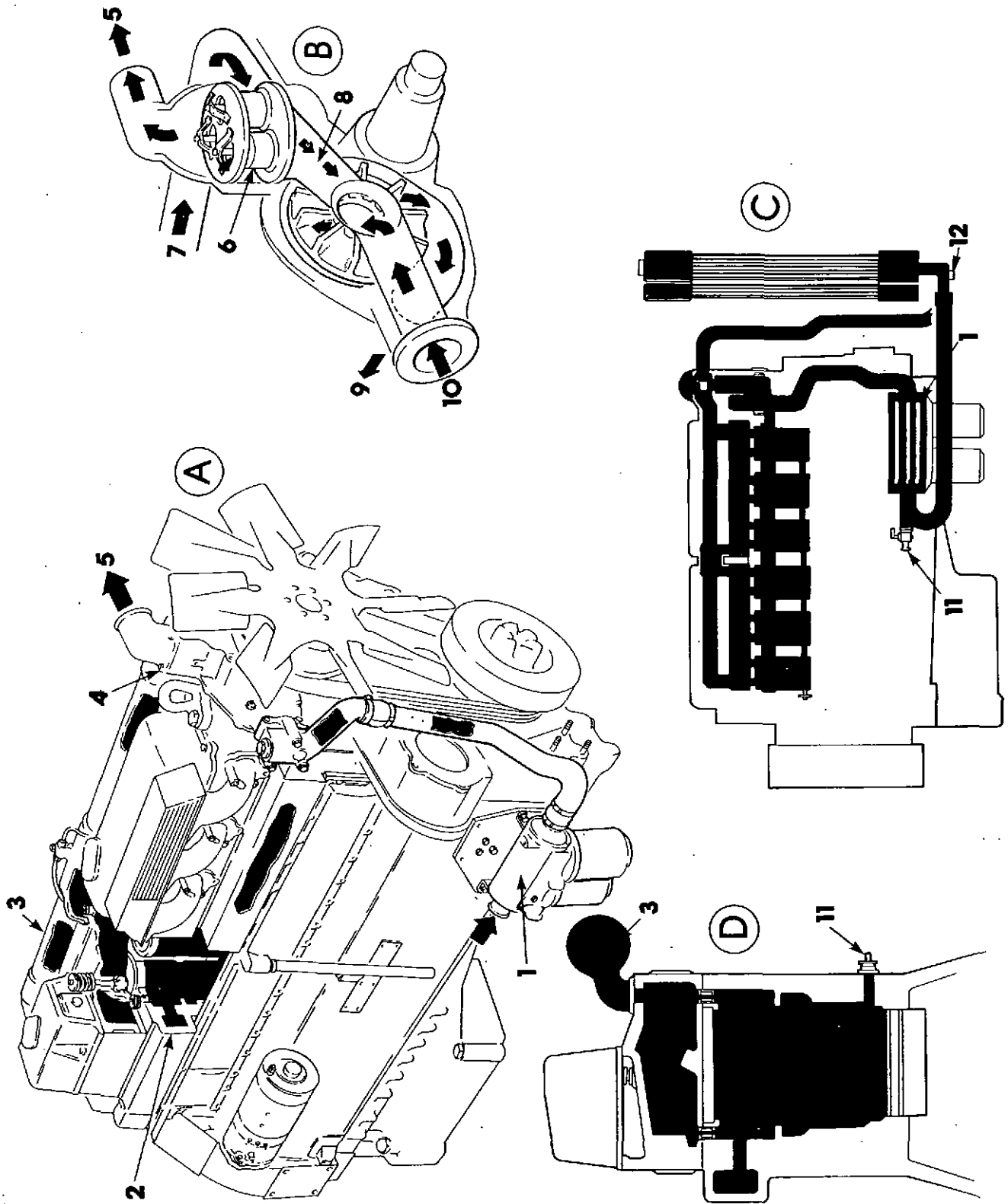
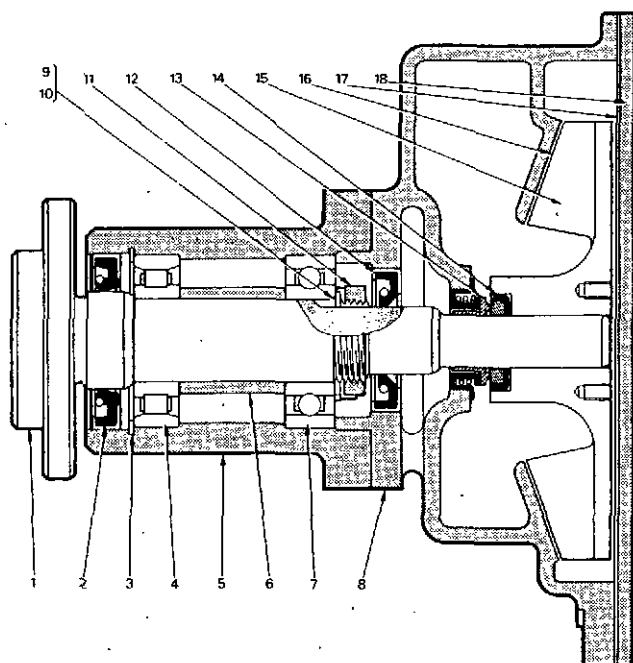

Fig. 1 Cooling system.



- | | | |
|-------------------|----------------|------------------------|
| 1 ROTOR SHAFT | 7 BALL BEARING | 13 GLAND SEAL UNIT |
| 2 OUTER SEAL | 8 PUMP CASING | 14 CERAMIC COUNTERFACE |
| 3 CIRCLIP | 9 LOCKWASHER | 15 ROTOR |
| 4 ROLLER BEARING | 10 TABWASHER | 16 RUNNING CLEARANCE |
| 5 BEARING HOUSING | 11 LOCKNUT | 17 JOINT GASKET |
| 6 DISTANCE PIECE | 12 INNER SEAL | 18 BACKPLATE |

24869

Fig. 2 Coolant pump

If the gland seal unit and ceramic counterface (13/14) are not in good condition, and in particular if their rubbing faces are even slightly worn or damaged, they should both be renewed together. Both units are rubber-mounted and renewal is by simple substitution, no special tools or sealant being necessary.

If possible, the inner and outer lipseals should be discarded and new items fitted as a matter of routine. In any case, they must be renewed if their condition is at all doubtful.

Assembling

Press the outer race of roller bearing (4) into the bearing housing (5) and fit the circlip (3). Fit the outer lipseal (2); with its lip facing outwards, and press it $\frac{1}{8}$ inch (3.2 mm) below the face of the bearing housing. In this position the seal is at mid-point of bore depth; if necessary it may be left flush with the face, or pressed fully home, to avoid a groove worn in the shaft by a previous seal.

Insert the rotor shaft (1) and fit the roller bearing and distance piece (6). Half-fill the bearing housing with Shell Retinax 'A' or equivalent grease. Do *not* overfill. Fit the ball race (7), followed by keywasher, tabwasher and nut. After tightening the nut, check

the shaft for free rotation before bending up the locking tabs.

Press the inner lipseal into the pump casing (8), so that the lip faces forward (fig. 2) and the seal casing is flush with the rear face. Bolt the bearing housing to the pump casing.

Ensure the rotor shaft and rotor bore are free from grease, and that the seal faces are perfectly clean, and press the rotor into position, flush with the end of the shaft. Check that the rotor does not foul the casing when turned. Before finally fitting the backplate (18) measure the rotor vane running clearance as indicated in fig. 2.

This clearance should be between 0.034 and 0.070 inch (0.86 and 1.78 mm).

THERMOSTAT

A triple-element wax-type Western Thomson thermostat is carried in a housing bolted to the top face of the coolant pump casting (fig. 3). The thermostat is located in its housing by a roll-pin which engages with a recess in the rim and ensures that each element is directly above a by-pass port. As the valves open the ports are shut off by the elements and the coolant is directed to the radiator. The

opening temperature of each valve is stamped on its element, the leading valve commencing to open at a slightly lower temperature than the other two.



Fig. 3 Thermostat in housing

T720024

A thermostat (fig. 4) with a vent hole pin and stainless steel valves and straps is fitted; the operating check data is as follows:

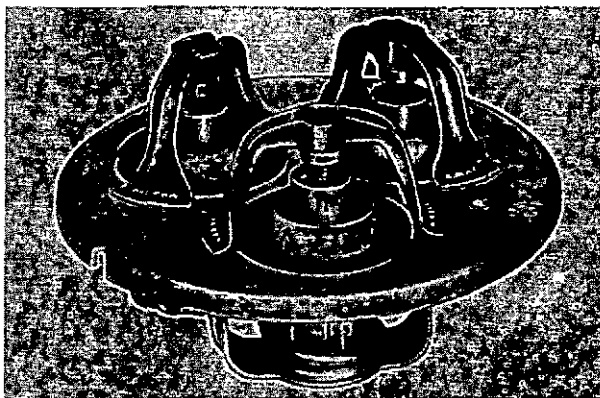

Fig. 4 Thermostat unit

T720064

To remove the thermostat, dismantle the thermostat housing cover, which is secured by four setbolts (fig. 3). After cleaning, inspect the unit for distortion, cracks and damage.

The thermostat requires no routine servicing and must be renewed if it becomes defective. Should one or more of the valves be sticking, this may often be rectified by applying a little silicone grease to the valve spindles and operating the valves by hand to work the grease into the glands.

Note: Silicone grease should be applied as above to the valve spindles of a replacement thermostat, or a thermostat fitted to an engine which is to stand with the coolant system drained. A suitable grease is Valve Seal 'A', manufactured by Midland Silicones Limited, 63 Temple Row, Birmingham 2.

Checking operating temperatures

1. Mark the strap of the leading valve and place the thermostat, right way up, in a container filled with water to the level of the valve platform. Position an accurate thermometer as close as possible to the valves.
2. Heat the water, and note the temperature at which the leading valve opens sufficiently to admit a 0.002 inch (0.05 mm) feeler gauge.
3. Continue heating and, in similar fashion, note the opening temperature of the two trailing valves.
4. Continue heating and note the temperature at which each valve is fully open, i.e. when it ceases to move after opening approximately $\frac{3}{8}$ -inch (9 mm).
5. Compare the readings with the following limits:

Leading valve opens:	77 to 81 deg.C (171 to 179 deg.F)
Trailing valves open:	81 to 85 deg.C (179 to 185 deg.F)
All valves fully open:	93 to 97 deg.C (199 to 207 deg.F)

Checking operating speeds

1. With all valves fully closed, immerse the thermostat, right way up, in boiling water to the level of the valve platform and note the time after immersion at which each valve opens sufficiently to admit a 0.002 inch (0.05 mm) feeler gauge.
2. Maintain the water at boiling point and note the time from immersion at which all valves are fully open.

3. Remove the thermostat and plunge it into cold water. Note the time taken for all valves to close fully.
4. Compare the readings with the following limits:
 - Leading valve commences opening: Within 15 secs
 - Trailing valves commence opening: Within 20 secs
 - All valves fully open: Within 60 secs
 - All valves closed in cold water: 4 to 8 secs

Emergency action, unserviceable thermostat

If a replacement thermostat is not available it will be necessary, *as a temporary measure only*, to jack the

valves fully open and run the engine with the radiator partly blanked off. *In no circumstances should the engine be run without a thermostat, since the by-pass ports would then be permanently open, causing overheating.*

OIL-TO-COOLANT HEAT EXCHANGER

Description and instructions for overhauling this component are given in Section 11, 'LUBRICATION SYSTEM':

SPECIAL TOOLS

GA.7 Extractor, pump rotor.

Printed in Great Britain

FITS AND CLEARANCES

COOLANT PUMP

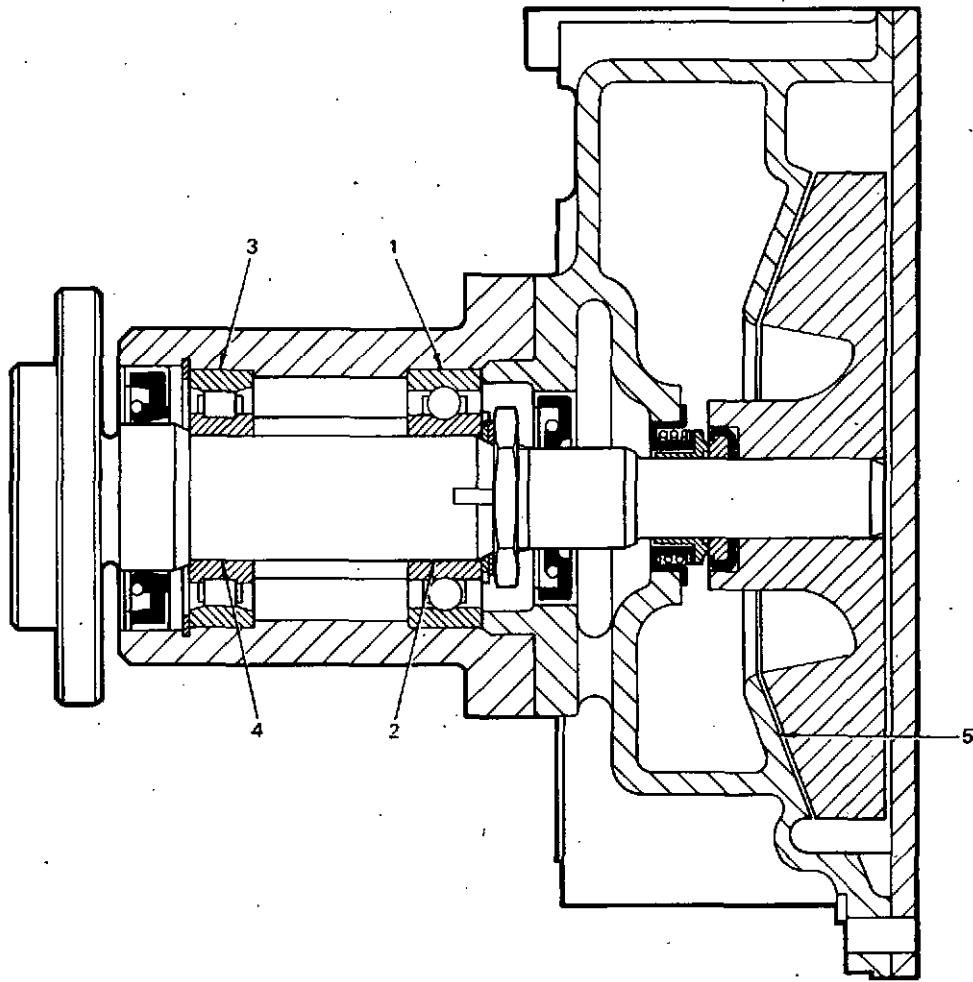

24871

No. ON DIAG.	DESCRIPTION	DIMENSIONS NEW		PERMISSIBLE WORN DIMENSIONS		CLEARANCE NEW		PERMISSIBLE WORN CLEARANCE		REMARKS
		in.	mm.	in.	mm.	in.	mm.	in.	mm.	
1	ROTOR SHAFT BALL BEARING Bearing in housing Housing—bore Bearing—dia.	2.407 to	61.99 to							Renew bearing if endfloat exceeds 0.005 in. (0.13 mm)
		2.442	62.01			Interference 0.0002 to 0.0007	0.005 to 0.019 clearance			
2	Bearing on shaft Bearing—bore Shaft—dia.	1.1807 to	29.99 to							
		1.1813	30.00			Interference 0.0004 to 0.00025	0.010 to 0.006 clearance			
3	ROTOR SHAFT ROLLER BEARING Bearing in housing Housing—bore Bearing—dia.	2.407 to	61.99 to							
		2.442	62.01			Interference 0.0002 to 0.0008	0.005 to 0.020 clearance			
4	Bearing on shaft Bearing—bore Shaft—dia.	1.1806 to	29.99 to							
		1.1811	30.00			Interference 0.0005 to 0.00025	0.013 to 0.006 clearance			
5	ROTOR CLEARANCE Clearance between rotor and casing or adaptor					0.034 to 0.070	0.86 to 1.78			



SECTION 10—FUEL SYSTEM

Repair and overhaul work on injectors, pumps and governors should only be undertaken by suitably trained and equipped personnel, working in conditions which conform to a high standard of order and cleanliness. If these requirements cannot be met, the faulty or life-expired unit should be exchanged for one which has been reconditioned and tested at the factory.

PART 1—INJECTORS

Description

Each injector is of the 'low spring' type and consists of a closed type 'S' size nozzle, carried in a holder. The nozzle is made up of a valve and a body which are lapped together to form a replaceable unit. At the nozzle tip are radially-drilled spray holes, four on normally-aspirated engines and five on turbocharged engines. The nozzle holder contains a spring-loaded spindle, which holds the nozzle valve on its seat, and an adjusting screw for setting the spring pressure.

On all 'C-RH' engines the injector operating pressure is 220 atmospheres. Injectors currently fitted to production engines and supplied as spares are of

the 'controlled flow' type on which the nozzle spray holes are produced to closer limits than previously. Their Rolls-Royce Part Numbers are as follows:

- OD.17534: Normally aspirated engines
- OD.17532: Turbocharged engines

Dismantling

Place the injector, nozzle downwards, in holding plate OD.17162 and remove the capnut to expose the adjusting screw. Unscrew the adjusting screw and remove the shim, spring and spindle.

CAUTION: Until this has been done the nozzle capnut must *not* be unscrewed, or the injector will be damaged.

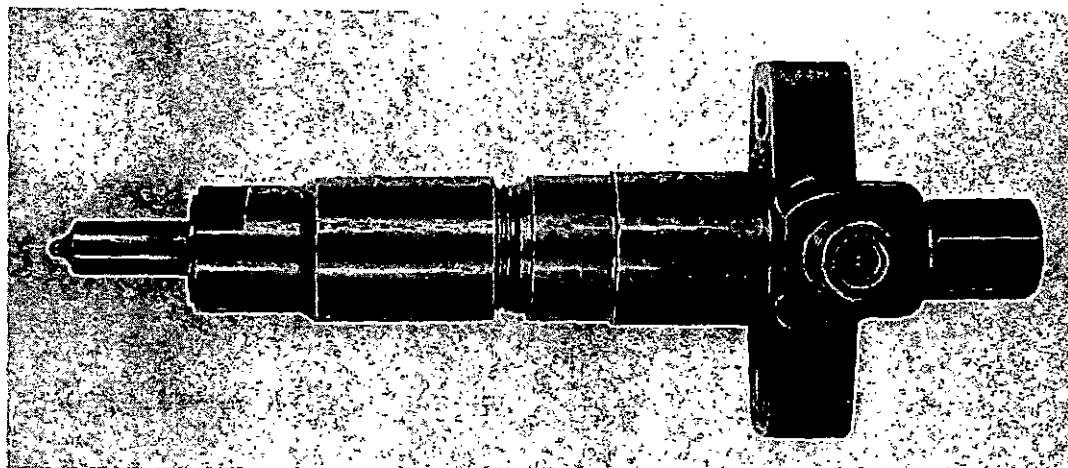

Fig. 1 Injector

T720056

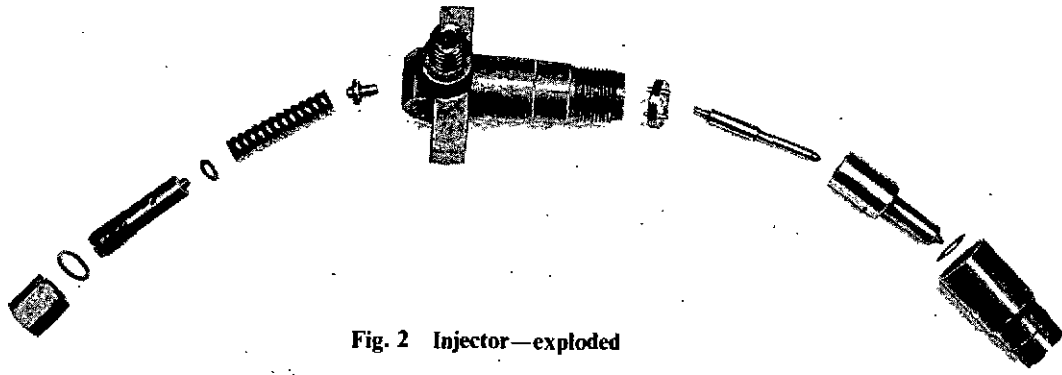

Fig. 2 Injector—exploded

T720057

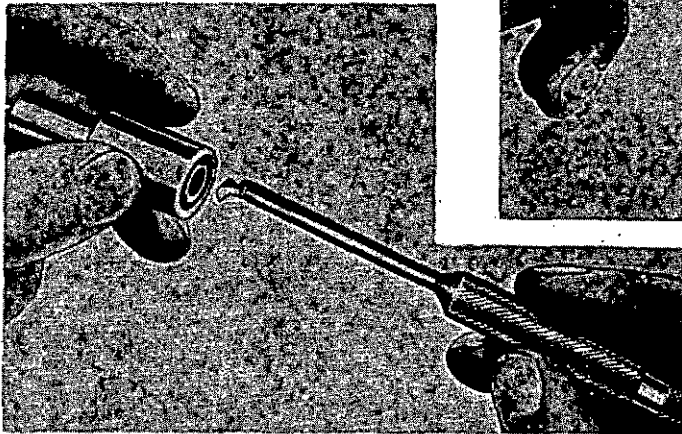
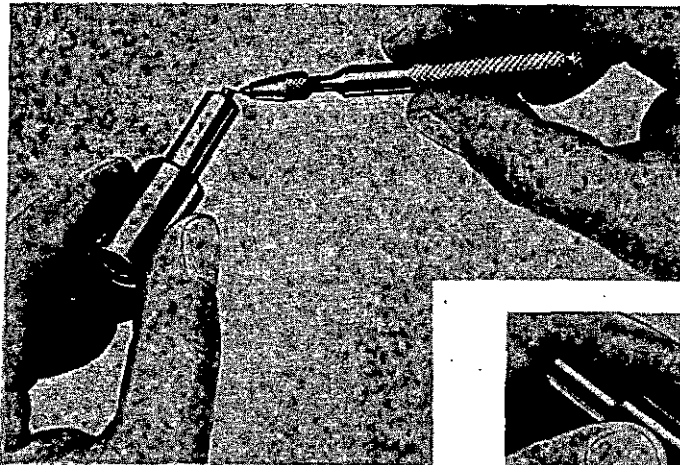

Fig. 3 Cleaning the nozzle

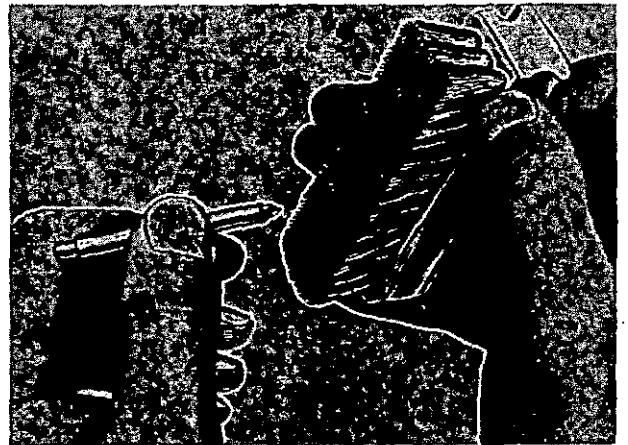
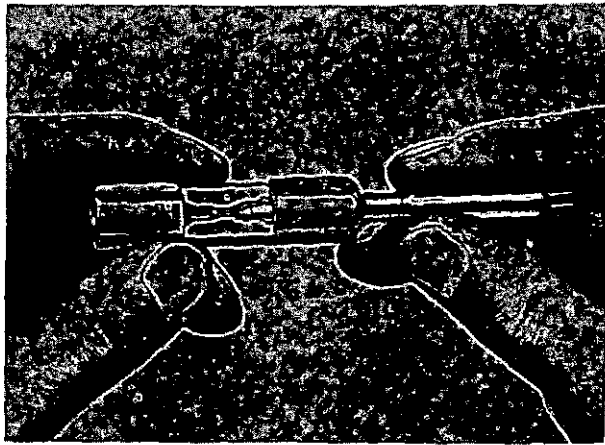

Fig. 4 Cleaning the nozzle valve

T720058

Reverse the injector in the holding plate and, using adaptor OD.13101, unscrew the nozzle capnut. Remove the nozzle and valve, and ensure that they remain together. Note that a 'skid washer' OD.14995 should be fitted beneath the nozzle shoulder (fig. 2). Remove the transfer block.

Cleaning

Wash the holder and its associated components in paraffin or fuel oil, and dry off with compressed air. Soak the nozzle assembly in a carbon solvent such as 'Ardrox' 690 or 1618, obtainable from Ardrex Limited, Commerce Road, Brentford, Middlesex.

Do *not* use a powered wire wheel to clean nozzle parts.

Remove any remaining carbon from the nozzle and valve by means of the tools in cleaning kit KRP.1089 as illustrated in figs. 3 and 4 (see also 'Use of cleaning wires').

Inspection

Check that the valve slides freely in the nozzle and is not scored or worn. If the valve face or nozzle tip are discoloured due to overheating, both components must be renewed.

DO NOT attempt to lap the valve to its seat, since their angles are not identical.

Inspect the pressure faces between holder, transfer block and nozzle for scratches and damage which would cause leakage under high pressure. Examine the spring and spindle for damage, distortion and corrosion.

Use of cleaning wires

Nozzle spray holes have nominal diameters of 0.355 mm. on normally aspirated engines and 0.36 mm. on turbocharged engines. It is important that all carbon is removed from their bores and cleaning wires are available in sizes to cover the manufacturing limits to which the holes are drilled. These wires are of D-section and are measured in millimetres across the full diameter.

Fit the wire to its holder so that not more than $\frac{1}{16}$ -inch (1.5 mm.) protrudes from the chuck. A greater protrusion increases the risk of wire breakage, and it is extremely difficult to remove a broken wire from a spray hole. Insert the wire with a twisting, scraping action until it has cleared the hole.

After every spray hole has been cleaned in this manner soak the nozzle again in solvent, as previously described under 'Cleaning', to dissolve any carbon remaining in the bores. Then assemble the nozzle to flushing tool OD.5178, attach it to setting outfit OD.16849, and flush through in reverse-flow direction to dislodge any loose fragments.

Assembling

Assemble the valve to its nozzle whilst both are immersed in clean test oil.

Fit the 'skid washer' OD.14995 to the nozzle shoulder (fig. 2) and the transfer block to the holder, ensuring that they are aligned as in fig. 5.

Engage the nozzle with the dowels on the transfer block and fit the nozzle capnut, hand-tight.

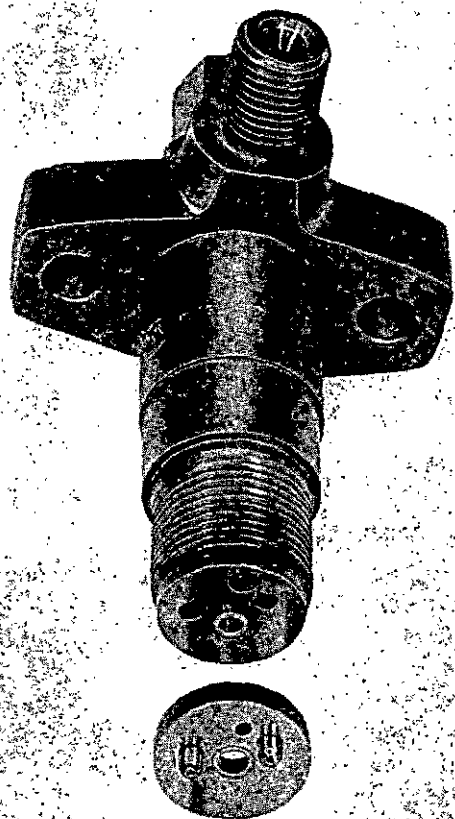

Fig. 5 Alignment of transfer block

T720059

Place the injector, nozzle upwards, in holding plate OD.17162 and use torque spanner adaptor OD.13101 to tighten the nozzle capnut to 50lb.ft. (68 Nm).

Invert the injector in the holding plate and fit the spindle, spring and shim. Screw the adjusting screw to its approximate setting, and temporarily fit the washer and capnut.

Setting and testing

This is carried out in three stages, using the nozzle setting outfit OD.16849. Only Shell Calibration Fluid, Esso TSD Oil 815 or Castrol Calibrating Oil 8327 should be used.

WARNING: When testing an injector, the nozzle must be turned away from the operator, since the spray has sufficient force to penetrate the human skin.

1. Pressure setting

Close the pressure gauge valve, and operate the pump smartly to expel air. Open the valve ¼-turn, operate the pump slowly, and note the pressure gauge reading at which the needle 'flicks', indicating nozzle valve opening. Turn the adjusting screw as necessary to give an opening pressure between 225 and 230 atmospheres, to allow for settling down in service. Fit and tighten the capnut, taking care not to disturb the setting of the adjusting screw.

Dry the nozzle tip, pump up the pressure to 210 atmospheres, and maintain it for 10 seconds. The nozzle should remain dry; slight dampness is acceptable but there must be no droplets.

2. Back-leakage check

Pump up a pressure of 160 to 165 atmospheres. Allow the pressure to fall naturally to 150 atmospheres, and then note the time taken to continue falling from this point to 100 atmospheres.

The time should not be less than six seconds and, in the absence of other leaks, a shorter time indicates excessive leakage past the lapped portion of the nozzle valve.

Before rejecting a nozzle assembly ensure that leakage is not due to dirt on the pressure faces and, in the event of an unusually high number of rejections, check that the fault does not lie within the test rig.

Note: Do not attempt to rectify leakage by over-tightening the nozzle capnut.

3. Atomisation check

Close the pressure gauge valve, pump up the pressure until the nozzle commences to spray, and continue to pump at about three strokes every two seconds. Check that all sprays are of equal size and fully atomised, and that after spraying the nozzle is dry.

Storage

Following satisfactory completion of the tests, wipe the injectors dry, fit their protective caps and store them in a clean warm place until required for use.

Note that new rubber sealing rings OE.43694 beneath the injector flanges will be required on assembly to the engine.

SPECIAL TOOLS

Rolls-Royce Part No.	C.A.V. Part No.	Description
OD.17162	7244-61	Injector holding plate
OD.16849	7144-644E	Nozzle setting outfit
OD.5178	7044-137	Nozzle flushing tool
OD.13101	7144-879	Spanner adaptor, nozzle capnut
KRP.1089	7244-10	Nozzle cleaning kit*

*Containing the following tools for Rolls-Royce injectors:

OD.5167	7044-68	Wire brush
OD.12504	7044-124	Nozzle body seating scraper
OD.12505	7044-69A	Scraper holder
OD.12506	7044-69E	Cavity scraper, 1.2 mm. dia.
OD.17243	7044-69G	Cavity scraper, 1.8 mm. dia. (radiused end)
OD.5169	7044-71	Body groove scraper
OD.5170	7044-72	Nozzle valve seat cleaner
OD.5180	7044-120	Cleaning wire holder

Cleaning wires (supplied separately from kits, in tubes of 10):

OD.13157	7244-6G	Cleaning wire, 0.34 mm. diameter (4-hole nozzle, normally aspirated engines)
OD.13158	7244-6H	Cleaning wire, 0.36 mm. diameter (5-hole nozzle, turbocharged engines)

ROLLS-ROYCE DIESELS



PART 2—INJECTION PUMP, TYPE 'PE'

Note: Although some illustrations in the following text depict a 6-element 'Left-hand' pump, the operations and essential details apply equally to the 'Right-hand' unit.

DISMANTLING

1. It is important to provide adequate storage trays, those for paired or associated assemblies such as pumping elements and tappets being divided into numbered compartments to enable each assembly to be kept together.
2. Thoroughly clean the unit, and drain the lubricating oil by removing the feed pump and governor access cap.
3. Mount the pump on a suitable rig, such as the swivel vice 0-681 240-048 shown in fig. 6. Remove the rear cover and dismantle the governor as described under 'DISMANTLING' in Part 3.

4. Invert the pump and remove the bottom plate.
5. Referring to fig. 7, remove the six tappet access screws from the pump casing. In turn, bring each tappet to TDC and fit a holder 1 681 115 12F to lift and retain the tappet clear of the cam lobe. To do this, proceed as follows, dependent on the pump stroke:

On 12 and 13 mm bore pumps screw in the element and guide sleeve by hand and then finally tighten one turn using a spanner. Then fit the cap-screw by hand until the element reaches the tappet and use an Allen key to turn it half-a-turn further. Do *not* exceed this, or the element may foul the cam.

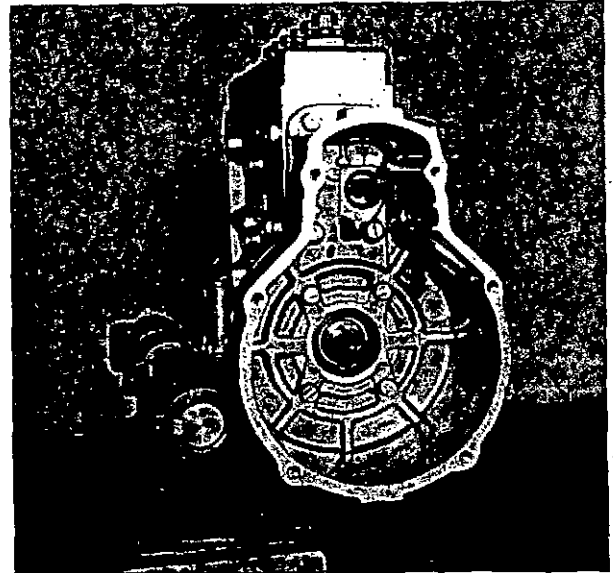

Fig. 6 Pump on swivel vice

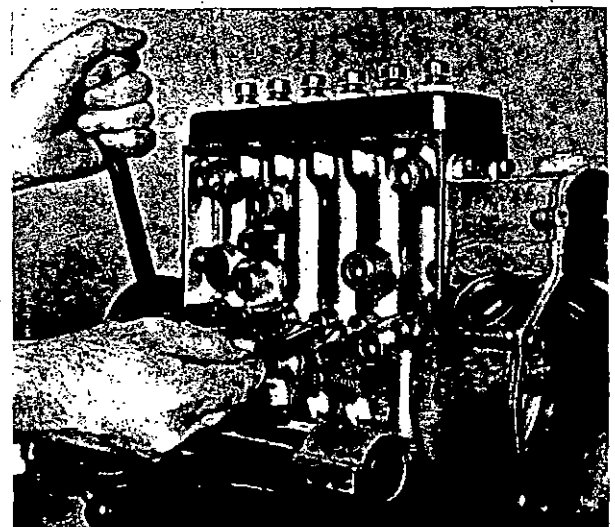

Fig. 7 Fitting tappet holders

6. Invert the pump and remove the camshaft centre bearing, which is retained by two socket screws (fig. 8).

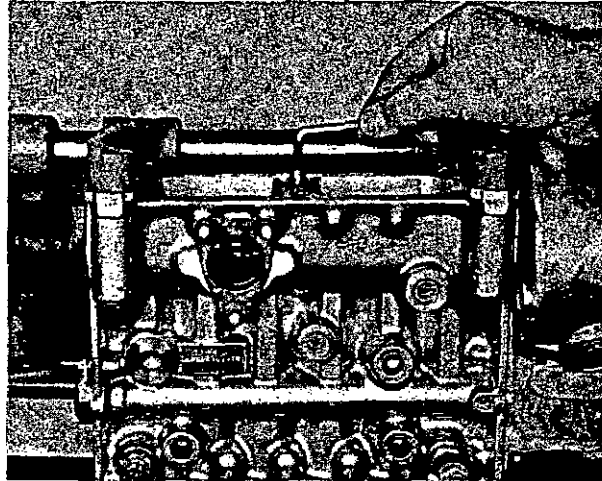

Fig. 8 Removing centre bearing

7. Turn the pump upright and remove the screws securing the drive end bearing plate. Referring to fig. 9, fit supporting bracket 1 682 329 011 and withdraw the bearing plate by using a claw extractor engaged in the recesses provided. The supporting bracket is necessary to avoid transferring load to the opposite end bearing via the camshaft. Remove the 'O' ring and shims from the end plate recess.

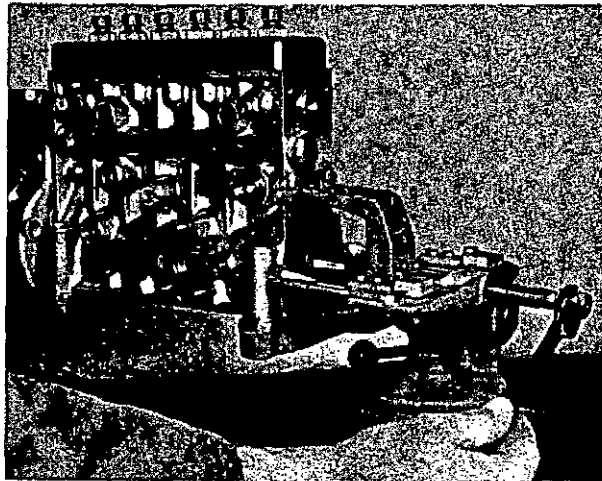

Fig. 9 Withdrawing drive end bearing plate

8. Withdraw the camshaft (fig. 10).

9. Remove the governor housing and adjusting plate from the opposite end (fig. 11).

10. Invert the pump, fit element spring compressing tool 1 688 110 027, together with pivot bar 1 683 001 003 and, on each tappet in turn, push the roller down, remove the tappet holder and unload the plunger spring (fig. 12).

11. Withdraw the roller tappets (fig. 13), use a wire hook to lift out the spring plate and pump plungers (fig. 14) and take out the plunger springs (fig. 15). Place each assembly in the appropriate compartment of its storage tray.

12. Set the control rack to mid-position and remove the control sleeves and upper spring plates (fig. 16).

13. Unscrew the smoke stop or excess fuel device assembly, together with its adaptor, from the drive end.

14. Using pin spanner 1 687 950 075, unscrew the threaded bush (fig. 17) and pull out the control rack and its dowel pin. Remove the control rack guide at the drive end by means of a wire hook and then use a long drift to tap out the guide at the governor end.

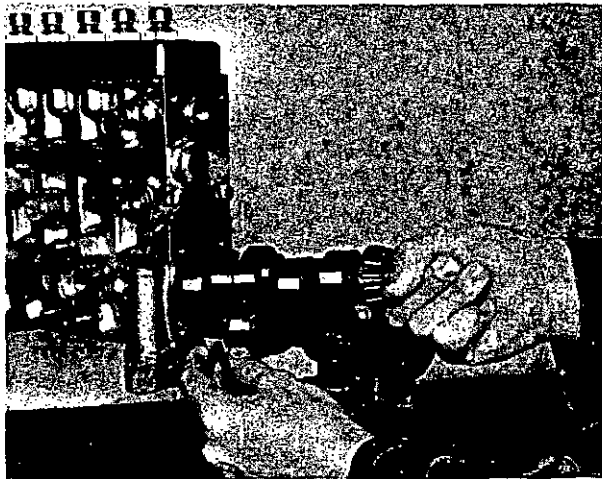

Fig. 10 Removing camshaft

15. Turn pump upright and remove the top cover. Unscrew the nuts securing the delivery valves and remove their washers. Extract the delivery valves, using tool 1 688 110 026 (fig. 18), ensuring that each assembly is stored in the same compartment as its associated components removed in Operation 11. Remove any packings which may have remained in the housing (fig. 19).

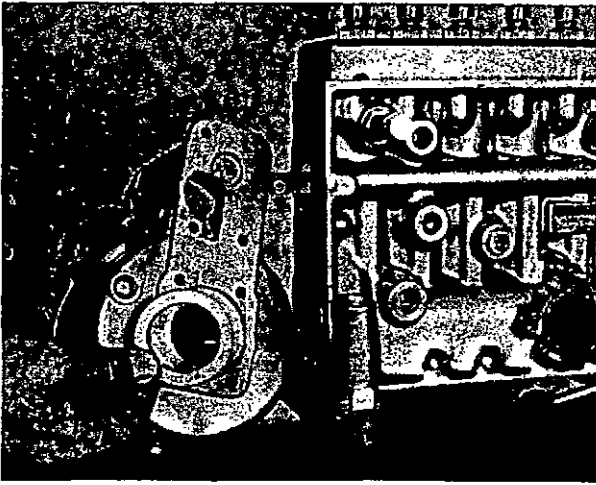

Fig. 11 Removing governor casing and adjusting plate

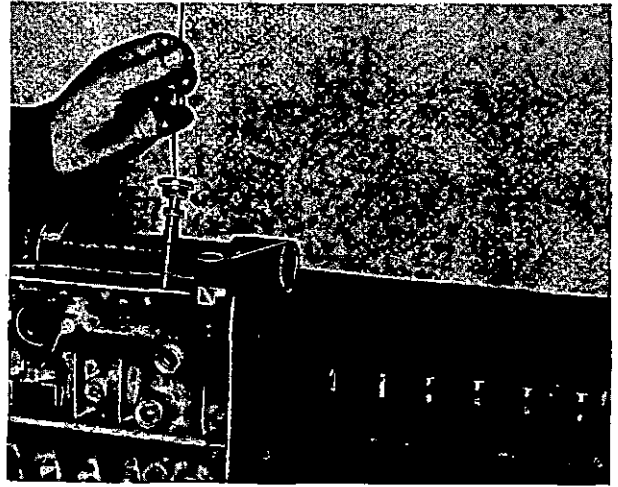

Fig. 14 Withdrawing plunger and lower spring plate

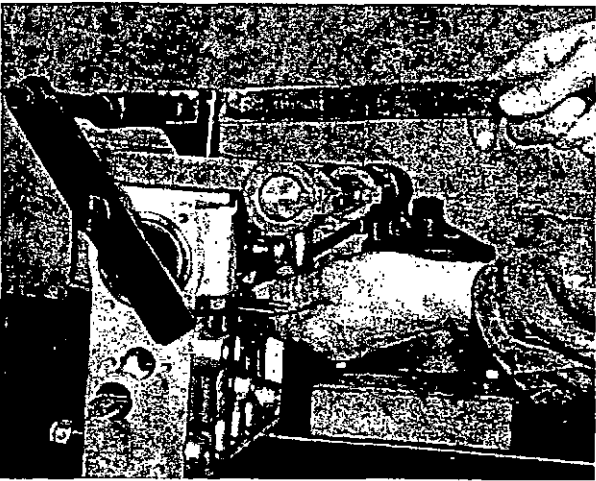

Fig. 12 Unloading plunger springs



Fig. 15 Extracting plunger springs

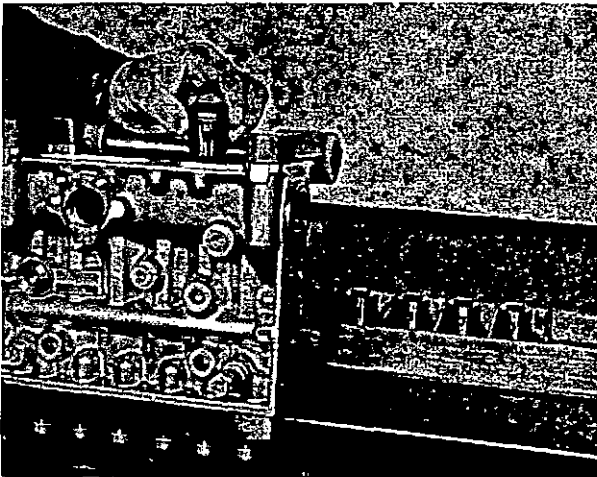

Fig. 13 Removing tappets

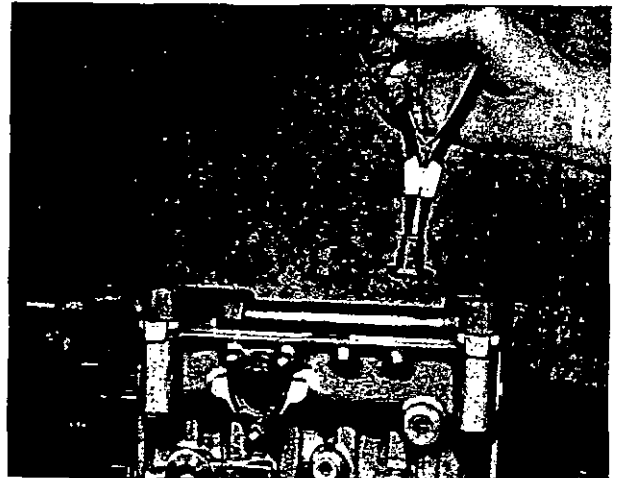

Fig. 16 Removing control sleeves and upper spring plates

16. Remove the circlip, baffle sleeve and 'O' ring from pump barrel. Remove 'O' ring, nylon ring and phasing shims from delivery valve flanged bush. Using mounting device 1 682 310 031 and ring spanner 1 687 950 525 (fig. 20) unscrew the connector from the flanged bush and remove the spring, delivery valve and washers.

CLEANING AND INSPECTION

Remove and discard all seals, joints and 'O' rings. Clean all parts in petrol or paraffin, using a soft brush, and dry them with a compressed air jet. Do NOT use cloth or rag for this purpose. Ensure that paired or associated components remain together.

Element plungers and their barrels must not be deeply scored, and the plunger helices should have clean sharp edges. If a plunger or barrel are unserviceable both components must be replaced by a mated assembly. Similarly, the delivery valve collar should not be deeply grooved and its face and seating must be unworn; these items must also be renewed as an assembly even if only one is unserviceable. When reconditioning a pump after prolonged service it is advisable to renew all pumping element and delivery valve assemblies as a matter of routine, thereby simplifying adjustment on the test rig and ensuring long-term reliability.

Inspect all other components for wear and damage, replacing them where necessary. Pay particular attention to cam lobes, tappet rollers, bearings and the ball notches in the control rack.

ASSEMBLING

1. Check camshaft projection as follows:

- (a) Remove bearing outer race at governor end (fig. 21). Then press it in again until it protrudes 0.118 inch (0.3 mm), as shown by dimension 'a' in fig. 22.
- (b) Place the adjusting plate on the outer race, fit the joint washer and governor housing and lightly tighten the securing screws. Then press the assembly fully home (fig. 23) fully tighten the securing screws.
- (c) Insert the camshaft, complete with front and rear bearings but without centre bearing. Fit drive end bearing plate with same shims as found during dismantling, but omitting the 'O' ring, and tighten the retaining screws

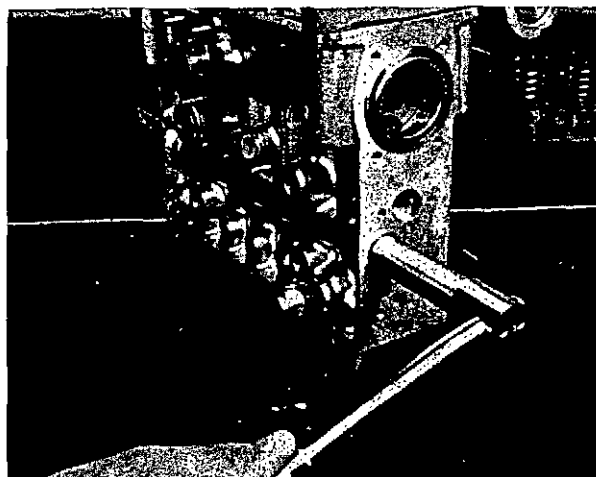

Fig. 17 Unscrewing threaded bush

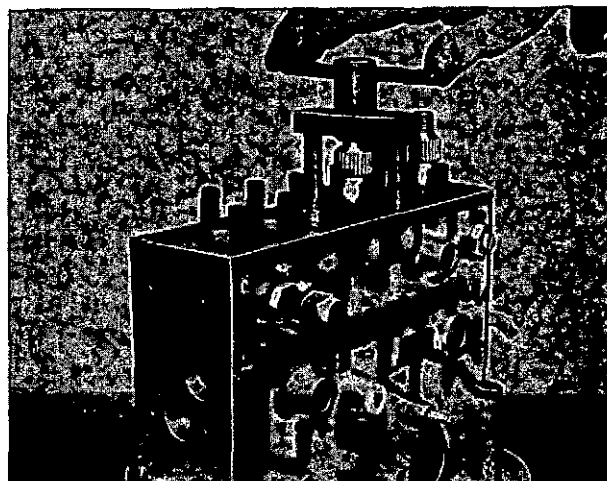

Fig. 18 Extracting delivery valve

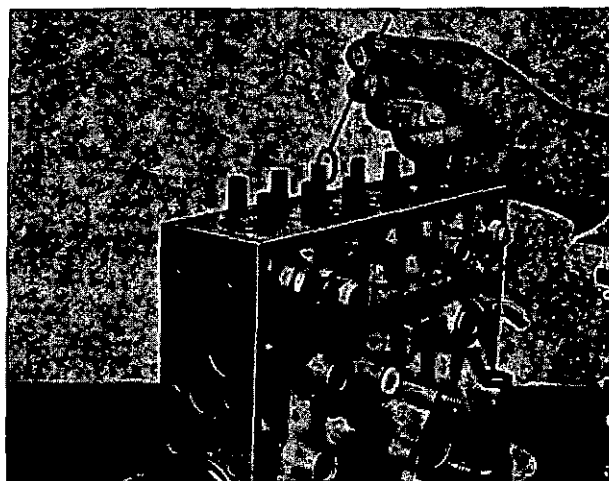

Fig. 19 Removing packings from housing

firmly. Press measuring bar 1 682 310 018 on to the camshaft taper and measure the clearance between bar and pump housing (fig. 24). Limits are 0.512 to 0.551 inch (13 to 14 mm.). If *below* limits, fit an appropriately thicker adjusting plate at the governor end and press the outer race further in, as in (b) above. If *above* limits, repeat (a) and (b), using an appropriately thinner adjusting plate.

- (d) When the projection is correct, remove the governor housing, adjusting plate and camshaft.

2. Assemble the barrel/delivery valve assemblies as follows:

- (a) Using mounting device 1 682 310 031 clamped in a vice, refer to fig. 25 and fit flange bushing (1); then insert pump barrel (2) so that the notch on its collar engages with the peg inside the flange bushing (the barrel must drop into position under its own weight). Assemble delivery valve (3), joint (4), spring (5) and washer (6). Fit 'O' ring (7) to connector (8) and screw the latter into the flange bushing (1). Finally, torque - tighten the connector to between 51 and 58 lbf.ft. (69 to 79 Nm) using socket 1 687 950 062 (fig. 26).
- (b) Refer to fig. 27 and slide washer (4) on to pump barrel (8) until it abuts against flange bushing (9); then assemble baffle sleeve (3), with its offset radial drillings away from flange bushing (9), and fit circlip (2). Finally fit Viton ring (1) to the lower groove of the pump barrel.

Note: Do not confuse this Viton ring with the rubber 'O' ring of similar size fitted to the pump casing bore. Distinguishing features are that the Viton ring is greyish in colour and slightly harder to compress. Fig. 28 shows the rubber ring 'a' and Viton ring 'b' under equal radial pressures.

Again referring to fig. 27, the 'O' ring (5), nylon ring (6) and phasing shims (7) are not fitted until the barrel/delivery valve unit is assembled to the pump housing (Operations 4 and 5).

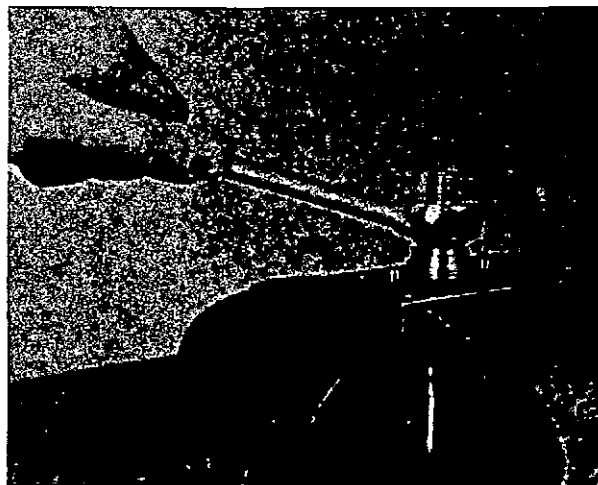

Fig. 20 Dismantling barrel/delivery valve assembly



Fig. 21 Removing outer race from governor end

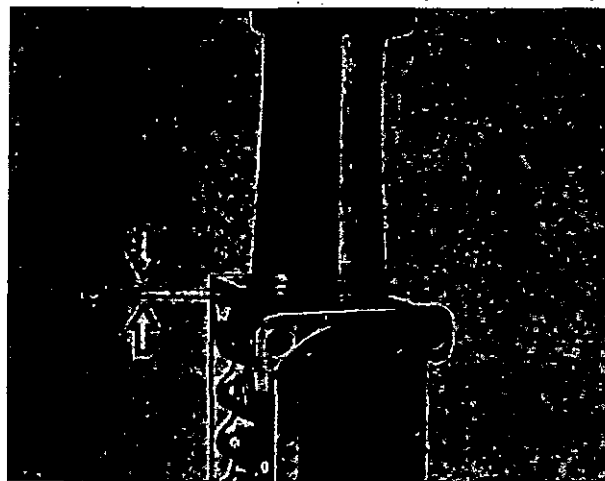

Fig. 22 Re-positioning outer race (first operation)

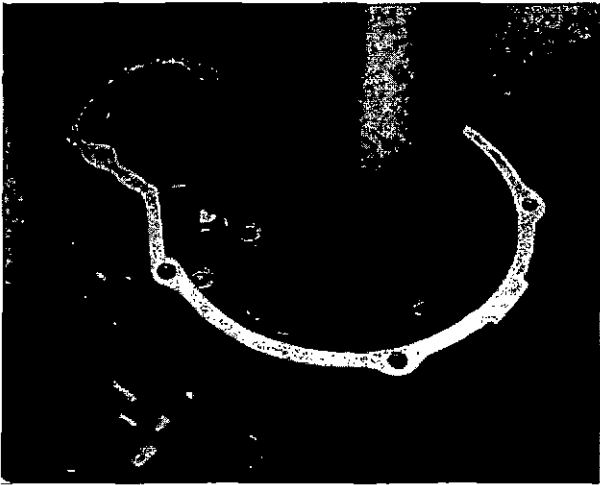

Fig. 23 Re-positioning outer race (second operation)

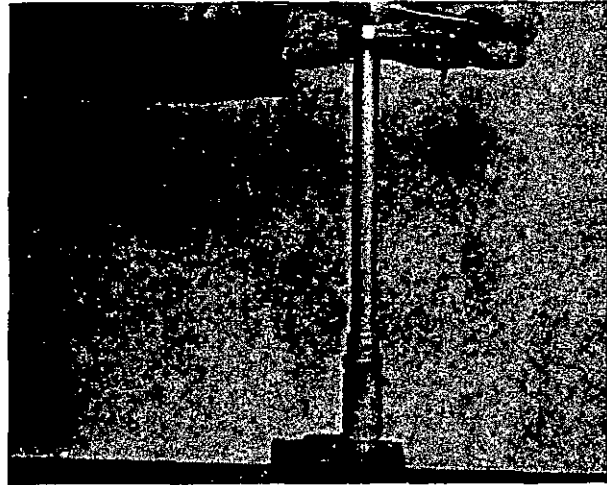

Fig. 26 Tightening connector

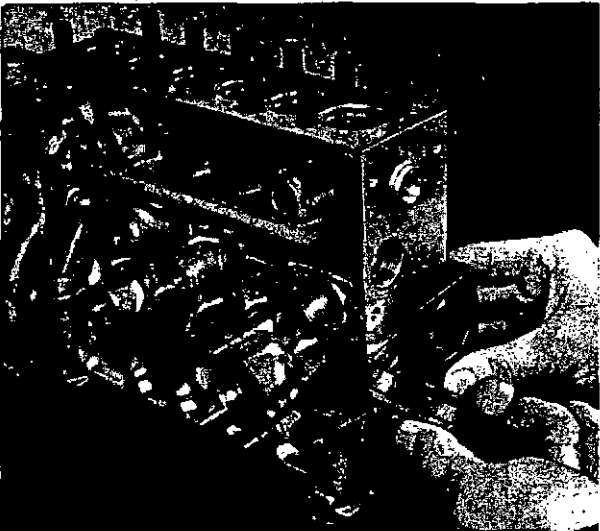

Fig. 24 Measuring camshaft position

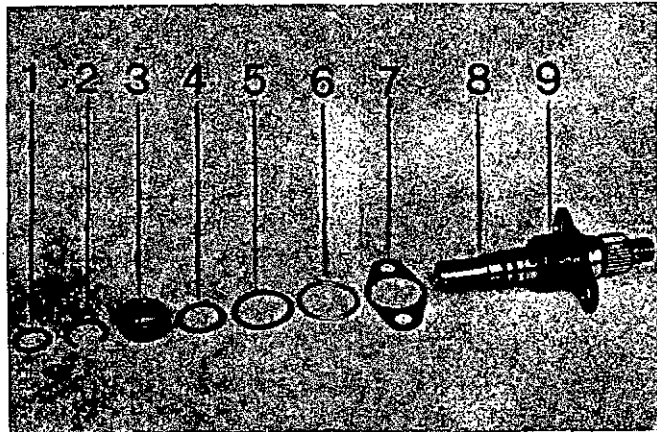

Fig. 27 Mounting components - barrel to pump casing

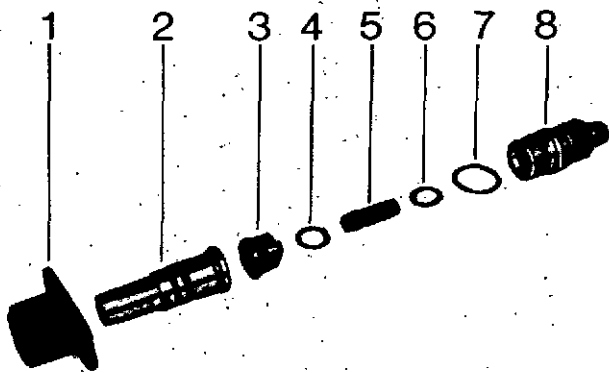

Fig. 25 Barrel delivery valve assembly - exploded

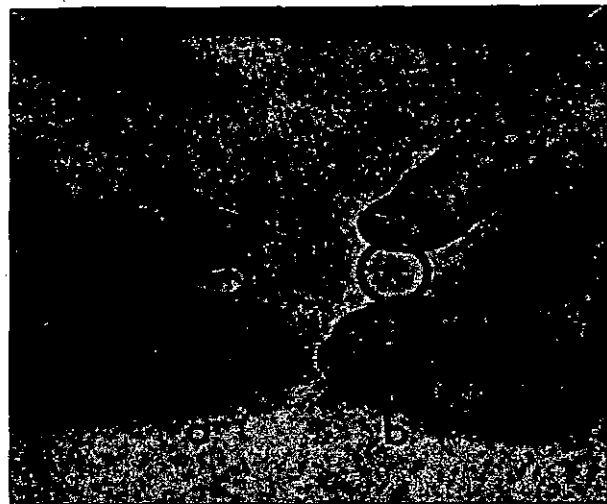

Fig. 28 Comparing rubber ring 'a' with Viton ring 'b'

Printed in Great Britain

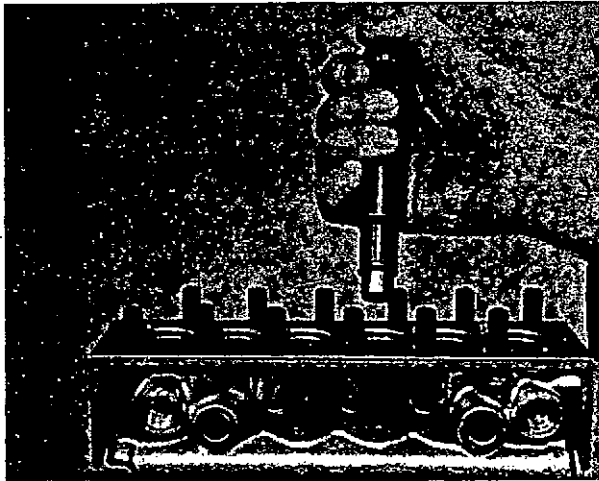

Fig. 29 Fitting rubber 'O' ring

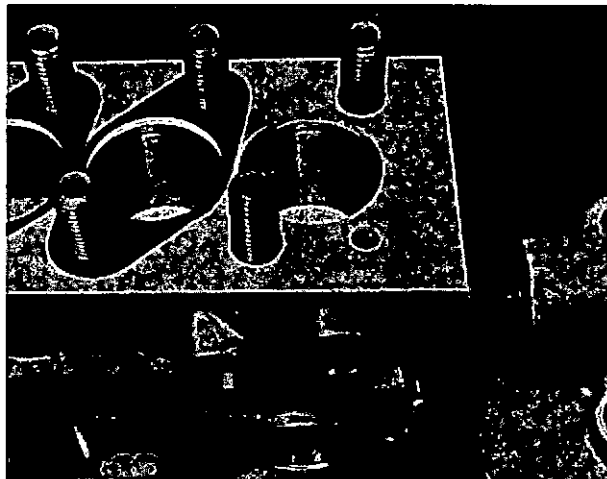

Fig. 30 Fitting 'O' rings, nylon rings and phasing shims

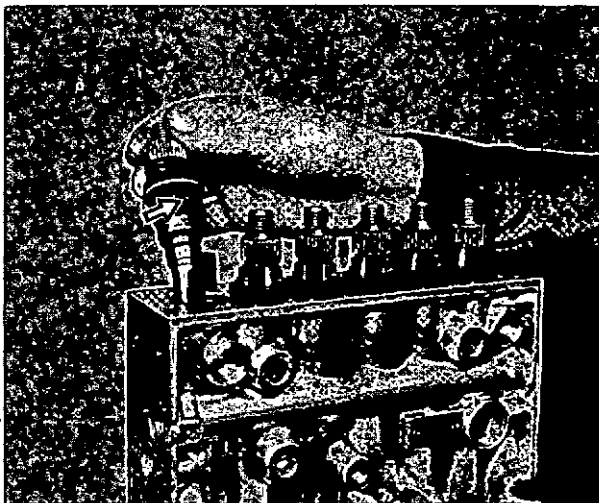

Fig. 31 Inserting barrel delivery valve assembly

3. Using tool 1 688 110 028, fit a rubber 'O' ring, see NOTE in 2 (b), to each bore (fig. 29). Depress tool plunger, fit a greased ring, enter tool fully into bore and release plunger.
4. Fit a greased 'O' ring, nylon ring and shim (fig. 27, Items 5, 6, and 7) to each port (fig. 30). NOTE: On pumps with numbers prefixed '626' and later the nylon ring is superseded by a steel ring permanently pressed on the flange bushing (fig. 25, Item 1), the port recesses are deeper, and protruding two-piece shims are used.
5. Insert the barrel/delivery valve assemblies, each with the drilling for the flange bushing peg (arrowed, fig. 31) towards the pump rack. Ease the units into place by gentle downward pressure and rocking, using ring spanner 1 687 950 525 (fig. 32). Fit the plain washers, spring washers and nuts, finger-tight; position each assembly with its securing studs at mid-point of the adjusting slots and tighten the nuts evenly to between 29 and 32 lbf.ft. (39 and 44 Nm).
6. Invert the pump, dip the plungers in clean fuel oil and fit them to their respective barrels, using pliers 0 681 340 003. Secure them by screwing six retaining pins (locally made from mild steel to the dimensions in fig. 33) into the tappet holder holes. Remove the pump from its mounting rig, connect an air-line to the fuel inlet gallery and blank off the spill connection. Immerse the pump, upside down, in fuel oil and admit air at 35 lbf./sq. inch (241 kN/sq.m) to the inlet gallery (fig. 34). There must be *no leakage* from the casting or pump barrels; this is *most important*, since any internal leakage (e.g. from damaged seals) can result in fuel oil entering the engine lubrication system via the injection pump. Small white bubbles at the plungers and delivery pipe connections may be disregarded.
7. Remove the pump from the test tank and re-mount it on the rig. Invert it and remove the retaining pins and plungers fitted for the pressure test.
8. Enter the control rack, with its guide block and travel limiting pin, from the governor end (fig. 35), aligning the vertical guide with the edge of the pump housing as shown.

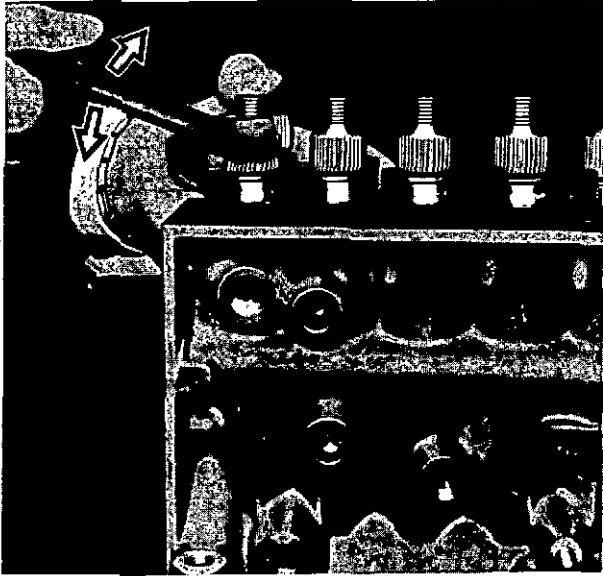

Fig. 32 Easing assembly into place

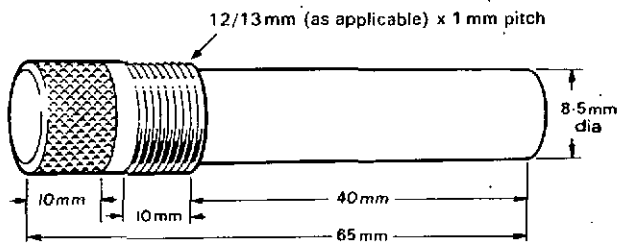

Fig. 33 Plunger retaining pin for pressure test

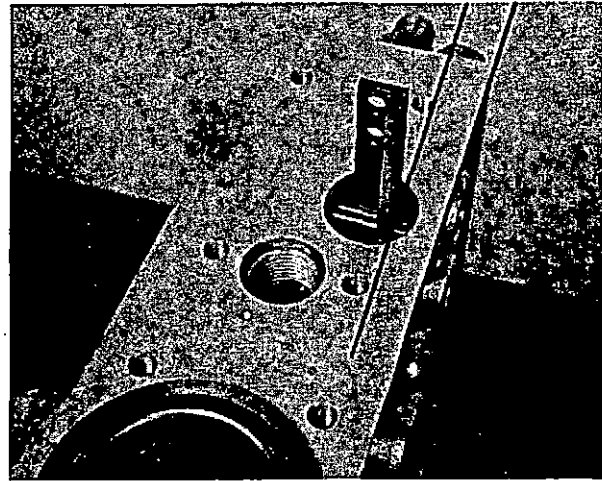

Fig. 35 Alignment of control rack

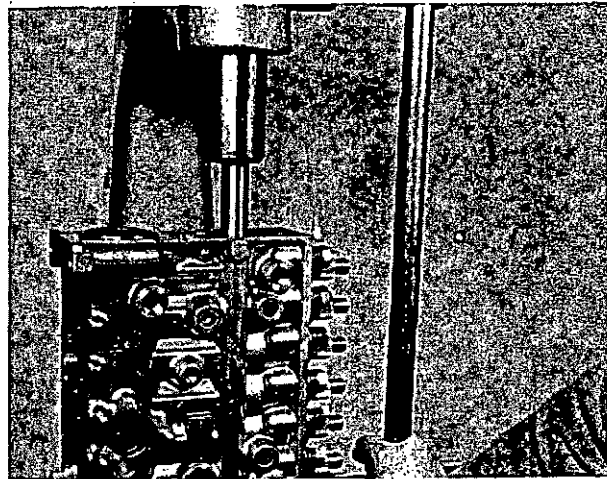

Fig. 36 Pressing in guide block

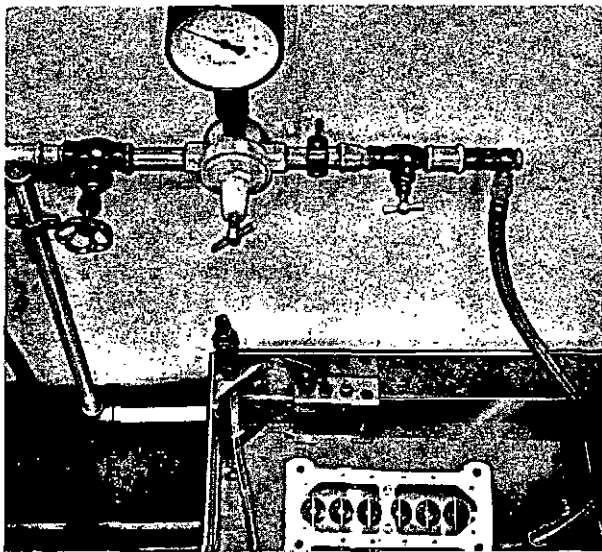

Fig. 34 Pressure test

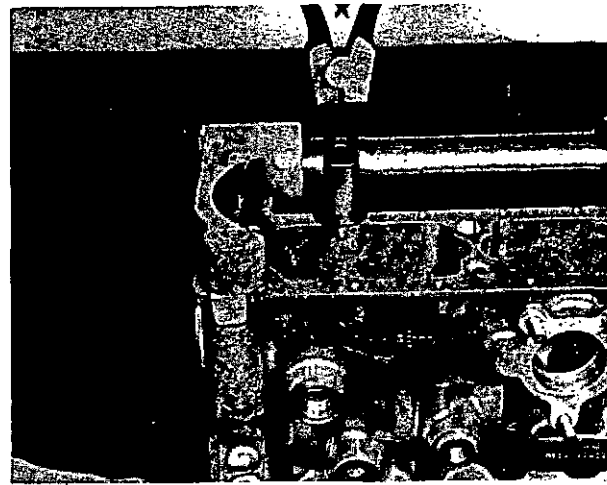

Fig. 37 Fitting control sleeves

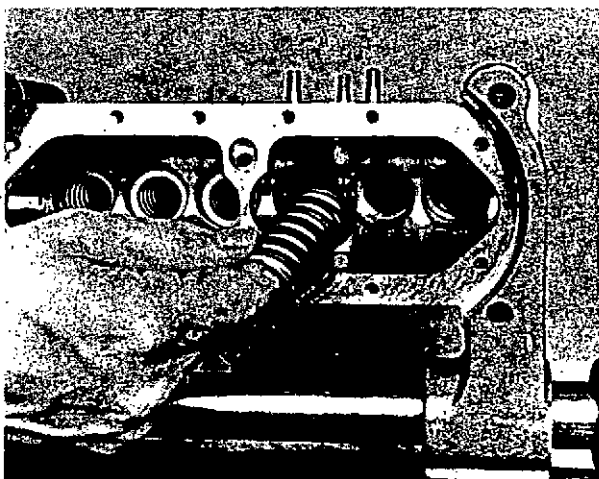

Fig. 38 Inserting upper plate and plunger spring

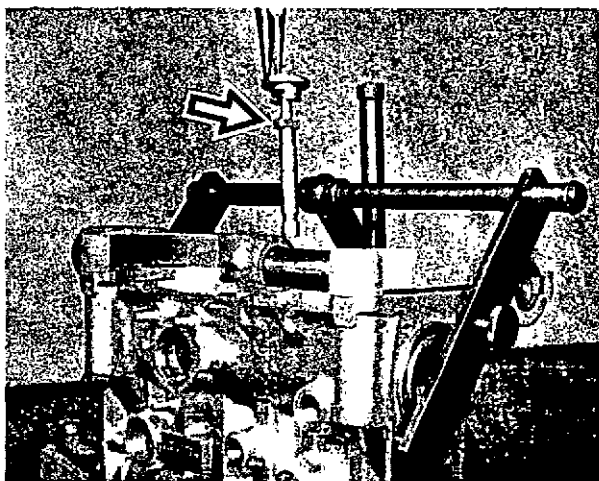

Fig. 39 Fitting plunger and lower plate

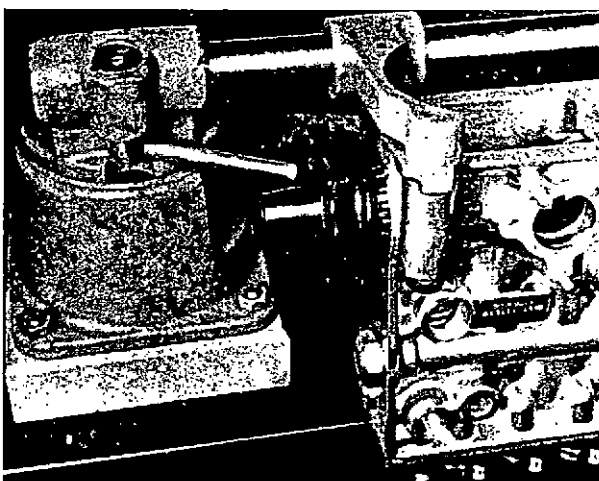

Fig. 40 Assembling drive end bearing

9. Use a suitable tube to press the guide block fully home (fig. 36), taking care that it does not become tilted. Secure it by screwing in the threaded bush to a torque loading of 22 to 29 lbf. ft. (30 to 39 Nm), using pin spanner 1 687 950 075.

10. Assemble the guide block at the drive end of the control rack (in this instance no pressure is necessary) and retain it by fitting the blanking plug.

11. Set the control rack to mid-position (i.e. with control sleeve notches in line with tappet guides) and fit the control sleeves (fig. 37), ensuring that in each case the driving ball is engaged with the rack notch. Check that the rack has free and full movement.

12. Insert the upper spring plates and plunger springs (fig. 38).

13. Fit spring compressing tool 1 688 110 027 and pivot bar 1 683 001 003 to the pump housing. On each element in turn:

(a) Fit the lower spring plate to its plunger and insert the assembly into its barrel (see fig. 39) with the line on the plunger towards the rack, as indicated by the arrow.

(b) Assemble the tappet, compress its spring and use holder 1 681 115 12F to retain it until the camshaft has been fitted. Screw the holder element and guide sleeve, without the capscrew, fully into the access tapping. Then fit the capscrew, tightening it until the tappet roller is 2.527 inches (64.2 mm) from the lower joint face of the pump casing.

14. Fit the governor housing and joint washer, together with the appropriate adjusting plate as determined in Operation 1. Enter the camshaft from the drive end and fit the new centre bearing tightening its two socket screws to between 5

and 6.5 lbf.ft. (8 to 9 Nm). Assemble the drive end bearing plate with shims, but omitting the 'O' ring (fig. 40).

15. Measure the camshaft end float by using tool 0 681 440 013, screwed on to the drivenut thread, and dial gauge 1 687 233 011, as shown in fig. 41. Limits are 0.0008 to 0.0024 inch (0.02 to 0.06 mm.). Adjust if necessary by varying the shims beneath the bearing plate. Fit the 'O' ring when finally assembling the bearing plate.
16. Using a new joint gasket, fit the base cover plate.
17. Turn the pump upright. In turn, bring each tappet to TDC and unscrew the tappet holder 1 681 115 12F (fig. 42). When all tappet holders are removed, fit the blanking screws to the tappet access holes.
18. Fit the feed pump. Assemble the governor as described in Part 3, prime the unit with engine lubricating oil, and carry out Test Procedure as described in Part 5.

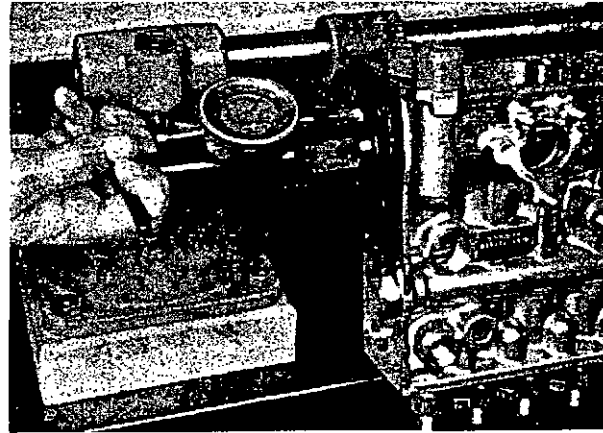

Fig. 41 Checking camshaft end float

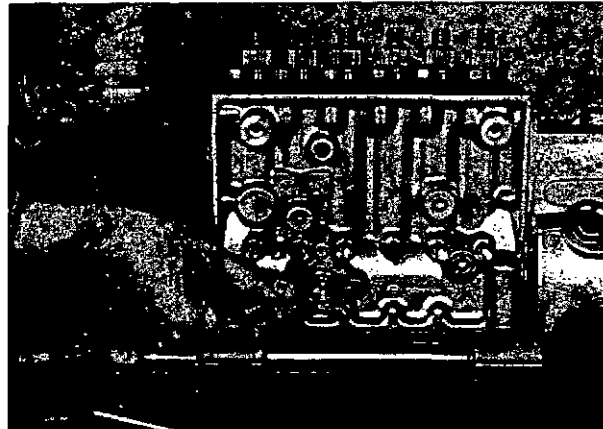

Fig. 42 Removing tappet holders

SPECIAL TOOLS — BOSCH 'PE' PUMP

Bosch Part No.	Description
0 681 240 048	Swivel vice
1 682 310 031	Mounting device, element
1 687 950 062	Spanner, socket, delivery valve connector
1 688 110 026	Extractor, element
1 680 363 001	*Extractor, governor flyweights
1 687 950 525	Spanner, open ring, delivery valve connector
1 681 115 12F	Tappet holder (one per element)
1 687 950 064	*Spanner, governor nut
1 688 110 027	Compressing tool, element springs, 6-element pumps
1 683 001 003	Pivot bar
1 682 310 018	Measuring bar, camshaft position
1 688 110 028	Inserting tool, 'O' rings in pump bores
1 687 950 075	Spanner, pin, threaded bush
0 681 340 003	Pliers, plunger inserting
1 682 329 011	Bracket, camshaft bearing plate extractor
1 688 130 019	Measuring tool, camshaft end float, less dial gauge
1 687 233 011	† Dial gauge for 1 688 130 019

*Also listed in 'SPECIAL TOOLS, BOSCH RQV GOVERNOR,' Part 3 of this Section

† Also listed in 'Special tools, Test Procedure,' Part 5 of this Section

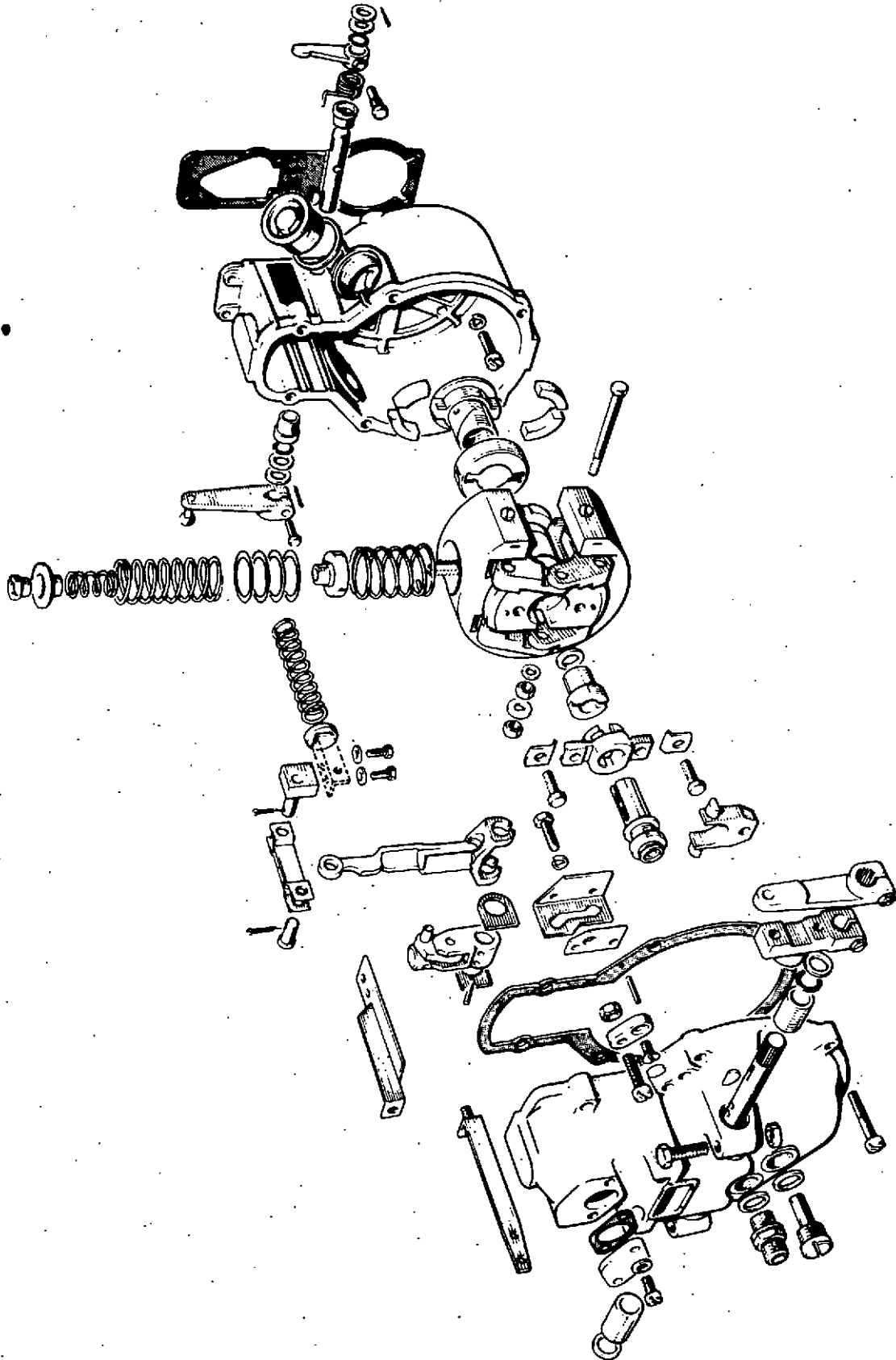

Fig. 43 Typical governor

ROLLS-ROYCE DIESELS

PART 3 — GOVERNOR, TYPE RQV

As explained and illustrated early in Part 2, the governor is best dismantled when it and the injection pump have been drained of lubricating oil (by removing the feed pump and filler plug) and mounted on a suitable rig, such as the swivel vice 0 681 240 048 shown in fig. 6.

DISMANTLING

1. Unscrew the guide pin (fig. 44, Item 'B') from the rear cover. This pin is assembled with sealing compound and its removal requires an adequate and well-fitting screwdriver.

Remove the six retaining setscrews and carefully tap the rear cover with a soft mallet to break the joint. Position the control arm vertically and withdraw the cover after raising it to disengage the sliding block (arrowed, fig. 45) from the floating lever (fig. 46, Item 'B').

2. Again referring to fig. 46, remove link pin 'A' and tie the link fork out of the way. Pull back the slider 'E' with the floating lever 'B', turn lever 'B' clear of the rack extension, swing it back 90 degrees and lift it away, together with the slider. Unlock and unscrew the nuts 'C' from the coupling bolt and remove the bolt. The adjusting pin 'F' can then be withdrawn from the governor hub. Unscrew the two bolts 'D' and remove the guide bush.

3. Clamp the camshaft at its drive end and, using spanner 1 687 950 064, remove the flyweight assembly retaining nut and, if applicable, end float adjusting washer.

Use extractor 1 680 363 001 (fig. 47) to withdraw the flyweight assembly from the taper on the pump camshaft.

INSPECTION AND REPAIR

Wash all parts in paraffin and dry off with a compressed air jet. Discard used joints, splitpins and tabwashers.

Inspect each component for wear and damage, renewing where necessary. If required, instructions for reclaiming certain parts (e.g. flyweights) may be obtained from the Manufacturer, but in general it is

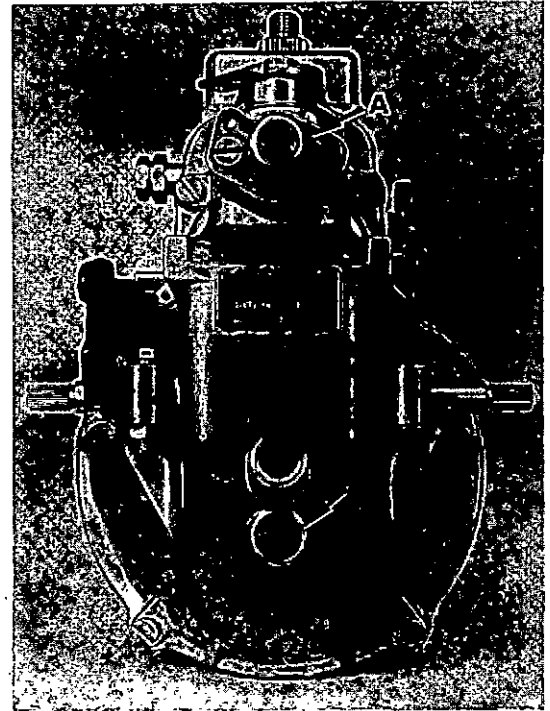

Fig. 44 Rear cover, showing rack access 'A' and guide pin 'B'



Fig. 45 Rear cover interior; sliding block arrowed

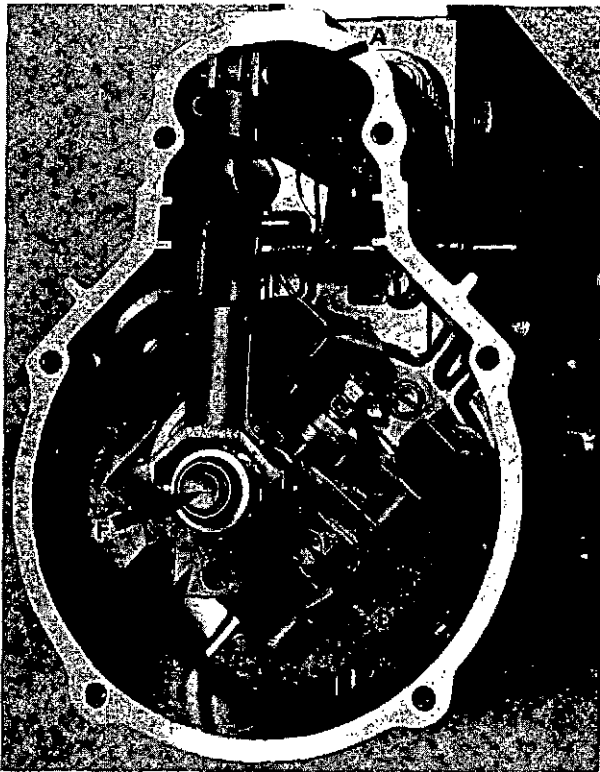

Fig. 46 Governor with rear cover removed

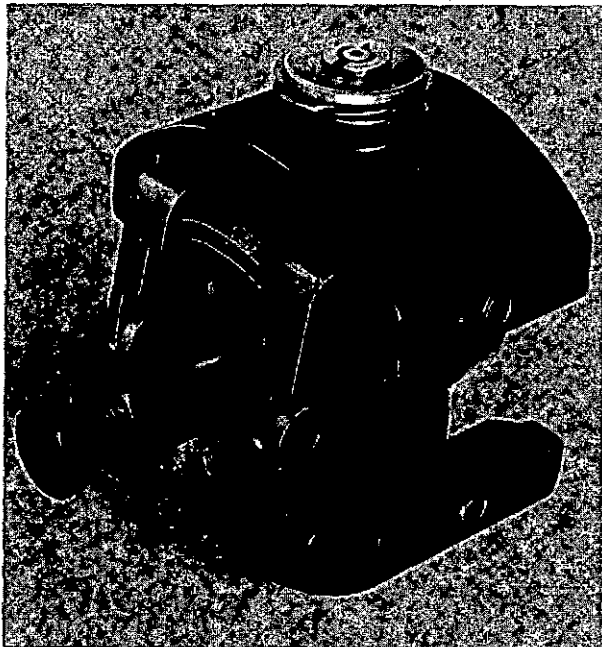

Fig. 47 Flyweight unit and extractor

recommended that if examination reveals excessive damage or accumulative wear the complete flyweight assembly be renewed. In addition to the rotating parts, closely inspect the linkwork, pins and guide slots for excessive clearances or damage, renewing components if defects are other than superficial (e.g. small burrs which can be stoned off) since these will tend to cause erratic governing.

Renewing flyweight assembly

If a new flyweight assembly is to be fitted its end float when mounted on the camshaft must first be checked and adjusted if necessary. For this purpose there must be no rubber blocks in the hub coupling.

Clamp the camshaft drive end, assemble the flyweight to its taper, fit the adjusting washer and retaining nut and tighten the nut to 36 lb. ft. (5 kg. m.). Check that, with the camshaft held stationary, the flyweight assembly can be rotated between the rubber block stops and has an end float of between 0.002 and 0.004 inch (0.05 and 0.1 mm.). Adjust, if necessary, by varying the thickness of the washer beneath the retaining nut. On completion of this check, remove the flyweight assembly from the camshaft and fit the rubber blocks to the hub as described below.

Renewing rubber blocks in hub

The four rubber blocks of the cushion drive in the flyweight hub may be renewed by levering the coupling out of the articulation piece (fig. 48).

Lightly lubricate the new blocks, and enter them whilst refitting the coupling (fig. 49). Take great care to avoid cutting or otherwise damaging the rubber. Finally, tap or press the coupling fully home in the articulation piece.

Renewing flyweight springs

Remove both sets of springs by unscrewing their retaining nuts with spanner 1 687 950 000. Note any shims beneath them. If replacement springs are to be fitted, refer to the Parts Book to ensure that they are of the correct type for the governor specification. When replacing springs, screw their retaining nut to the basic setting shown in fig. 50 ensuring that this is identical on both spring assemblies.

Note: Springs may be changed on an installed governor via the oil filler orifice, as shown in fig. 51. A special tool 1 683 455 000, which engages with the filler cap thread, is available for this purpose.

Adjusting pin

This pin (fig. 52) connects the flyweight coupling bolt to the slider in the governor hub. Check that its spring and bearing surfaces are serviceable. The setting of the pin should not be disturbed unnecessarily but if adjustment is unavoidable it should be carried out as described later, under 'ASSEMBLING' and also in Part 5, Stage 'B'.

ASSEMBLING

1. Ensure that the tapers of the camshaft and governor hub are clean and undamaged. Although a keyway may be machined in the camshaft taper, no key is used. Assemble the flyweight unit to the camshaft and fit the adjusting washer and retaining nut. Clamp the drive end of the camshaft and tighten the retaining nut to 36 lbf.ft. (49 Nm) using spanner 1 687 950 064. After tightening, check by moving the flyweight assembly about the camshaft that the cushion drive in its hub is free to operate.
2. Fit the guide bush, tighten its securing bolts (fig. 46, Item 'D') and bend up their locking tabs. A sectioned view of the governor assembled to this stage is shown in fig. 53.
3. Check that the internal spring of the adjusting pin (fig. 52) has no end play and yet is not compressed. Adjust, if necessary, by turning the castellated carrier bolt relative to the eyed bearing bolt at the opposite end. Finally, set the bearing bolt 2 mm. below the end face of the adjusting bush, as shown, and assemble the adjusting pin to the guide bush bore, securing it by temporarily fitting the coupling bolt (fig. 54), which passes through the eye of the bearing bolt.
4. Pull the adjusting pin rearwards sufficiently to draw the flyweights inwards, but without exerting excessive load on the internal spring of the pin. In this position the measuring gauge 1 682 329 038 should fit snugly into the slider recess of the adjusting pin (figs. 52 and 55). Adjust, if necessary, by means of the bearing bolt in the adjusting pin, as shown in fig. 54.
5. Assemble the coupling bolt so that it has end float of 0.040 to 0.080 inch (1 to 2 mm.), tighten its two nuts together and bend their lockwasher over one flat of each. Mount the slider and floating lever and fit the link pin, together with its splitpin (fig. 56).

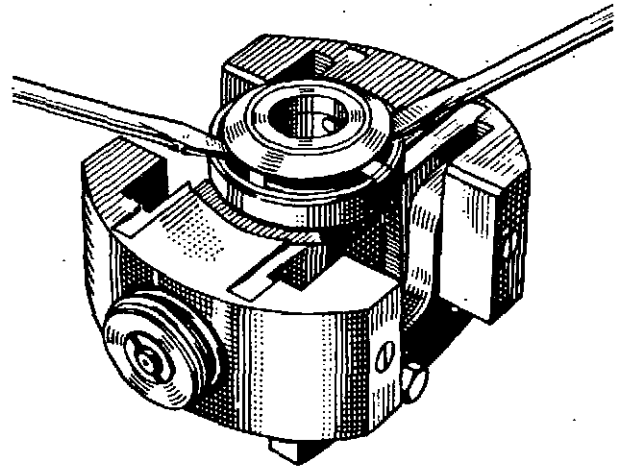

Fig. 48 Removing coupling and rubber blocks

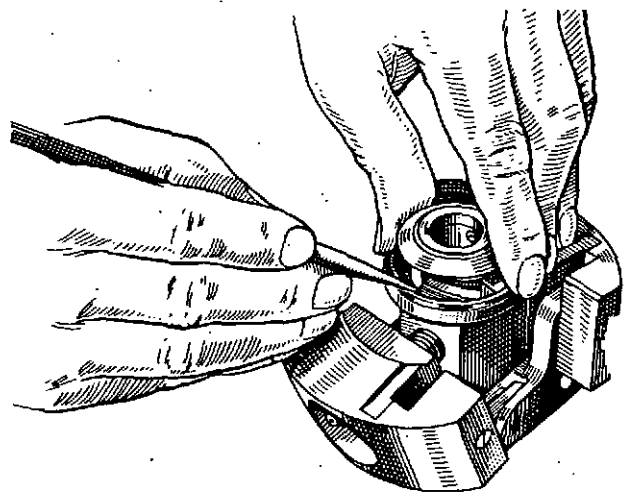

Fig. 49 Fitting coupling and rubber blocks

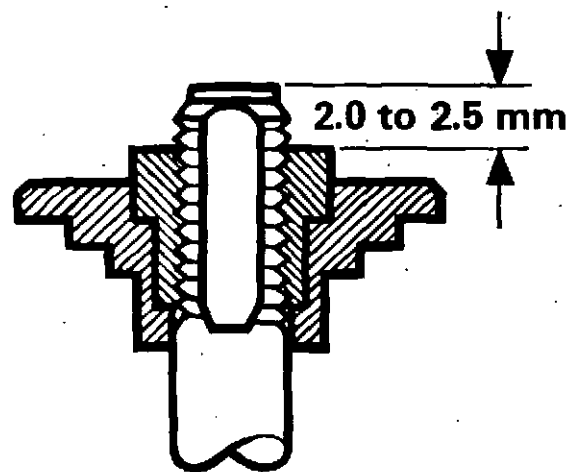

Fig. 50 Flyweight spring basic setting

Printed in Great Britain

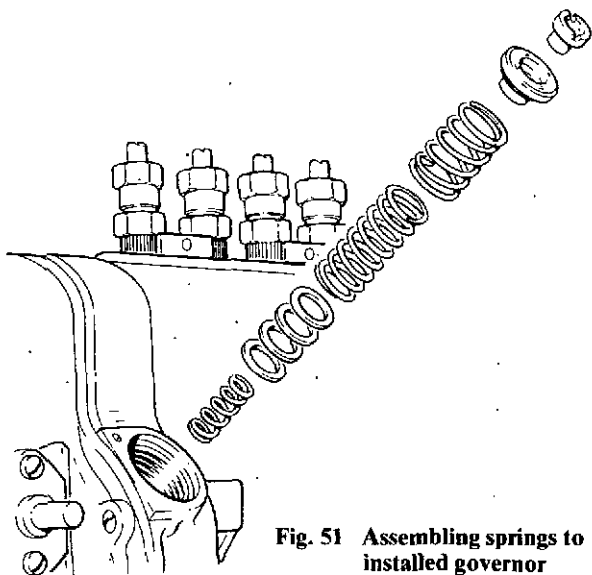

Fig. 51 Assembling springs to installed governor

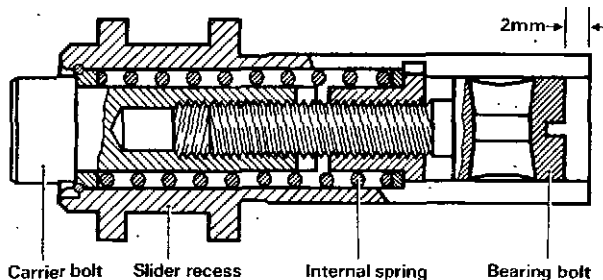

Fig. 52 Adjusting pin - sectioned

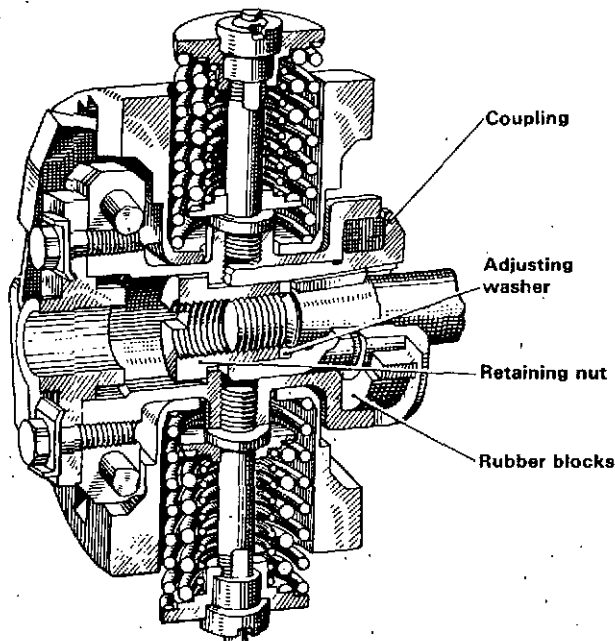

Fig. 53 Flyweight assembly - sectioned

6. Invert the governor rear cover and set the control lever to MAX. FUEL so that the pilot pin is at the bottom of the 'S' curve. Place a new gasket on the joint face and measure the distance between the gasket and the pilot pin, as in fig. 57. this dimension, to the *centre* of the pin, should be 0.965 inch (24.5 mm.). Using the depth gauge as illustrated, *deduct* from its reading the thickness of the measuring bar and *add* 0.118 inch (3mm.), which is half the diameter of the pilot pin. Adjust, if necessary, by means of shims beneath the 'S' curve plate.
7. Fit the feed pump and prime the injection pump with adequate engine lubricating oil for test running.
8. Final fitting of the governor rear cover is carried out during Stage 'B' of the Test Procedure (see Part 5). Concerning this, the following instructions are particularly important:
 - (a) Apply a non-setting compound to both sides of the joint gasket.
 - (b) Ensure that the sliding block is positioned with its long section uppermost (fig. 45) when it enters the slotted recess in the floating lever (fig. 46, Item 'B').
 - (c) Seal the guide pin thread with Loctite 241.

SPECIAL TOOLS — BOSCH RQV GOVERNOR

Bosch Part No.	Description
1 687 950 064	*Spanner, governor nut
1 680 363 001	*Extractor, governor flyweights
1 682 329 038	Measuring device, sliding sleeve position
1 683 455 000	Compressing tool, governor springs
1 687 950 000	Spanner, adjusting governor springs

*Also listed in 'SPECIAL TOOLS, 'PE' PUMP', Part of this Section

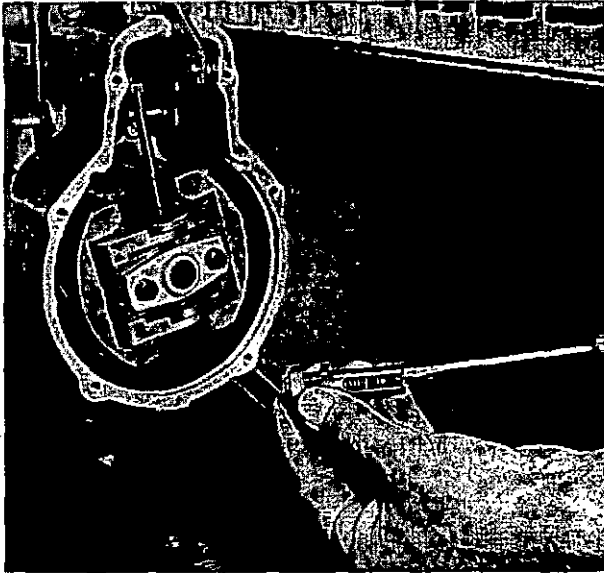

Fig. 54 Adjusting pin and coupling bolt

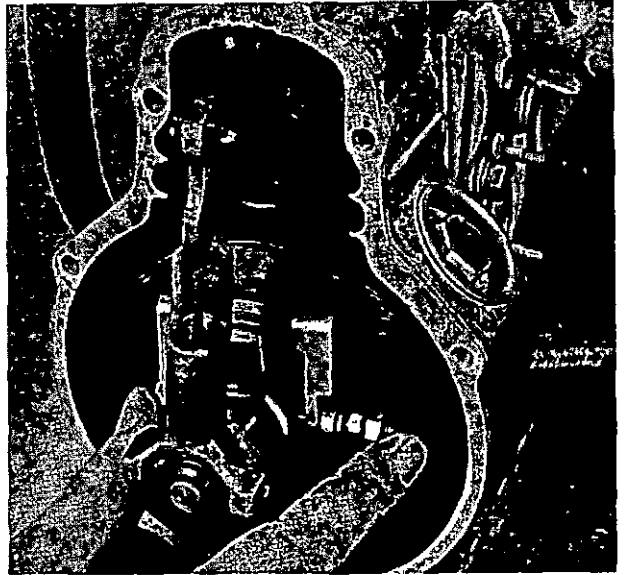

Fig. 56 Coupling bolt, floating lever and slider

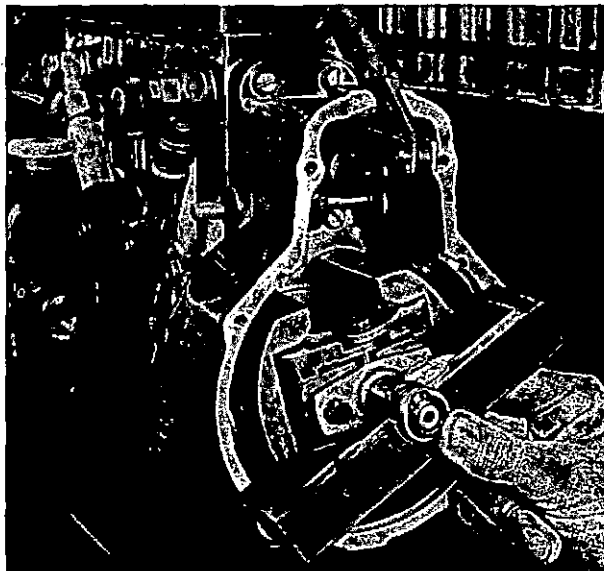

Fig. 55 Gauge for checking sliding sleeve position

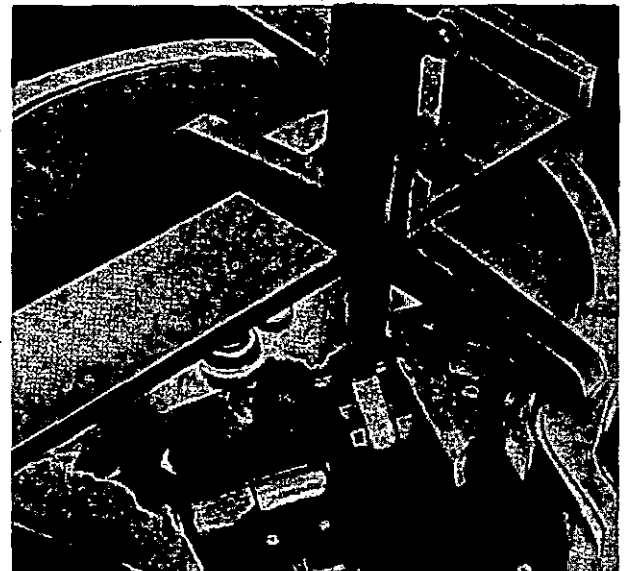

Fig. 57 Checking position of 'S' plate



PART 4 — FEED PUMP, TYPE FP/KD 22P**DESCRIPTION**

This pump (fig. 58) is of the spring-loaded plunger type, mounted on the injection pump and operated by a double eccentric on the camshaft. Four spring-loaded nylon valves, two inlet and two delivery, are carried in the pump body. A hand-operated plunger pump for priming purposes is mounted above one of the inlet valves; the plunger must be lightly screwed down against its sealing washer when not in use to prevent leakage of fuel.

DISMANTLING AND INSPECTION

Before removing the feed pump from the injection pump, slacken the priming pump casing, the blanking plugs above the remaining three valves and the plug retaining the plunger spring. Remove the priming pump and dismantle the four valves and their springs. Unscrew the plunger and spindle. Remove the circlip retaining the tappet assembly and withdraw the unit.

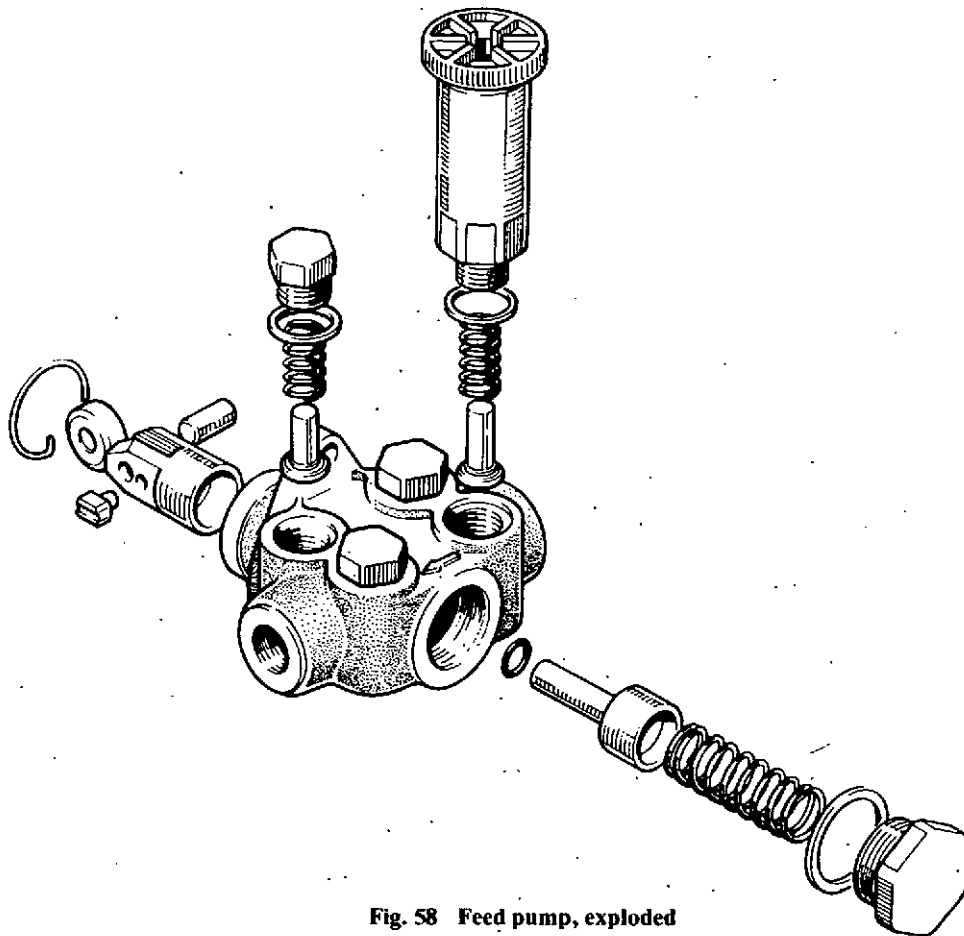

Fig. 58 Feed pump, exploded

Check that the valves are seating correctly and that their springs are in good condition.

Inspect the plunger and its spindle for wear and scores. NOTE: These two components are matched by the Manufacturer and identified by a colour code; replacements should be to the same standard. Check also that their spring is in good condition.

Examine the plunger and tappet bores in the housing for scores and wear. Renew the 'O' ring if its condition is at all doubtful. Dismantle the tappet assembly and inspect its components for wear and damage, renewing them as necessary.

Check the action of the hand priming pump. This cannot be dismantled and must be replaced as a unit if unserviceable.

ASSEMBLING

Ensure that all parts are thoroughly clean and lightly oiled. Assemble the pump in the reverse of dismantling sequence, using new joint washers. If possible, carry out a leakage test by blanking off the outlet connection and applying air pressure at 28 lbf./sq. inch (193 kN/sq.m) to the inlet connection with the pump immersed in fuel oil. Check for air bubbles, operating the plunger to ensure that there is no leakage from the tappet bore.

Check pump output during testing of the injection pump. The low-pressure relief valve is carried in the bolt securing the spill pipe banjo to the injection pump gallery and opens at 15 to 22 lbf./sq. inch (104 to 152 kN/sq.m); feed pump output pressure at operating speed should easily exceed this. If required, particulars of further tests involving special apparatus are available from the Manufacturer.

PART 5 — TEST PROCEDURE

EQUIPMENT SPECIFICATION

Printed in Great Britain

Bosch Part No.	Description
—	Test Bench, Bosch 385
1681 443 022	*Test injector, 175 ats., 12 mm and 13mm bore pumps (1 per element)
1680 750 060	*HP pipe, 12 mm and 13 mm bore pumps (1 per element)
1686 430 007	*Drive coupling
1417 413 025	*Overflow valve
1688 130 085	Measuring rig, plunger lift, less dial gauge
1687 233 011	† Dial gauge for 1688 130 085
1688 130 030	Measuring rig, rack travel, less dial gauge
1687 233 015	Dial gauge for 1688 130 030
1687 950 525	† Spanner, open ring, delivery valve
0681 440 006	Setting rig, control lever position
1688 130 095	Measuring rig, sliding sleeve travel

* If a Hartridge 1100 Test Bench is used these items are replaced by the following, and the Bosch FP/KD feed pump, together with its pressure relief valve on the injection pump, are included in the circuit.

Rolls-Royce Part No.	CAV/Hartridge Part No.	No. off	Description
—	7244-108	Set of 6	Test injectors, 175 ats., 12 and 13 mm. bore pumps
OD 18514	—	1 per element	HP pipe, 8 x 3 x 760 mm., 12 and 13 mm. bore pumps
OD 18526	AFB 27	4	Holding-down bolt
OD 18527	FP164	4	Banjo union
OD 18528	Banjo union		
OD 18529	AT 16/24/8	3	Banjo bolt, 14 x 1.5 mm
OD 18530	ALP 104	4	Pipe, flexible
OD 17531	FP 383	1	Drive coupling, 25 mm. taper
	—	8	Washer, copper, 14 mm.

† Also listed in 'SPECIAL TOOLS, BOSCH PE PUMP' (see Part 2)

Test Oils

Bosch: 01 61 v 11

Esso: Calibration Fluid 1L 1838

Shell (Overseas): Calibration Fluid B

Shell (UK): Calibration Fluid C

TEST SEQUENCE

Testing is done with the pump mounted on the test bench, using the equipment specified. The Test Schedule appropriate to the engine application, as listed at the end of this Part, is then carried out in the following three-stage sequence:

- A Pump pre-stroke setting, phasing and calibrating
- B Governor setting
- C Final setting of pump/governor assembly

**STAGE 'A' — PRE-STROKE SETTING
PHASING AND CALIBRATING**

NOTE: The operations in this Stage are carried out with the governor rear cover removed.

1. Pre-stroke setting

This involves setting the plunger lift to port closure on No. 1 element, as follows:

- (i) Remove the LP relief valve assembly and fit a blanking plug similar to that at the other end of the inlet gallery.
- (ii) Unscrew the access plug to No. 1 tappet (see fig. 59, Item 'A') and turn the camshaft until No. 1 tappet is approximately at BDC.
- (iii) Referring to fig. 60, fit measuring rig 1 688 130 085 to the access plug tapping, ensuring that the probe rests on the upper edge of No. 1 tappet, as in the inset. Assemble dial gauge 1 687 233 011 to the rig and set it to zero.

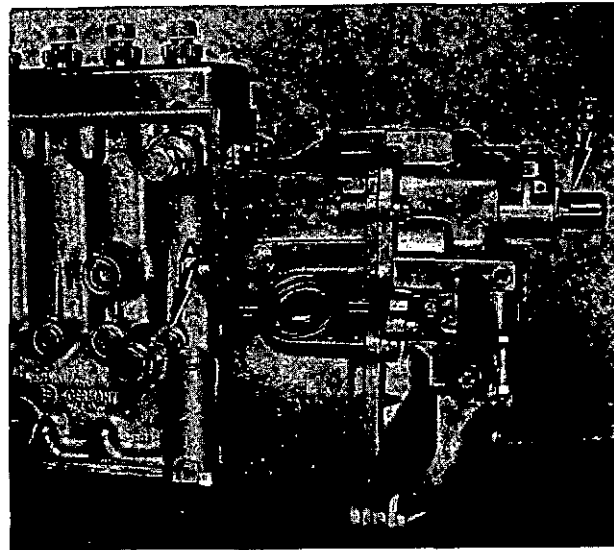

Fig. 59 Tappet access plug 'A'. Rack stop locknut 'B'

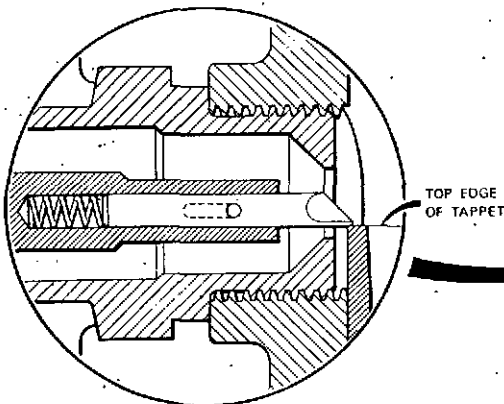
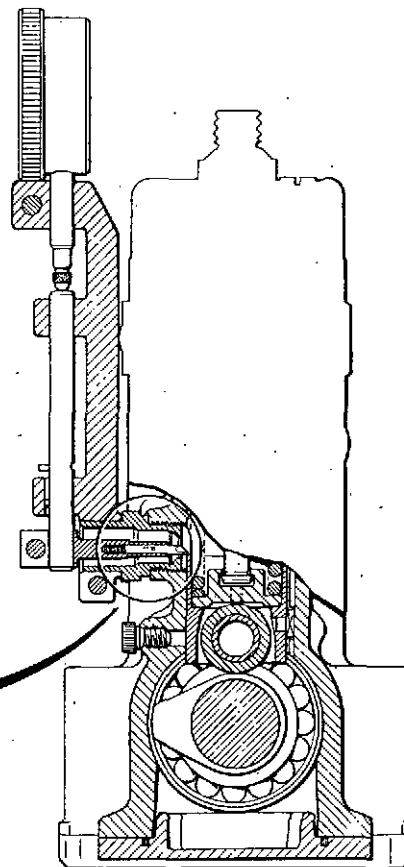

Fig. 60 Measuring plunger lift to port closure



- (iv) Switch on the feed pump of the test bench. Open the leak-off screw on No. 1 test injector and increase feed pressure until oil emerges from it.
- (v) Turn the pump camshaft manually in direction of rotation (clockwise, viewed from drive end) until oil just ceases to flow from the leak-off. The dial gauge reading at this point should be within the limits specified against 'Plunger lift to port closure' in Stage 'A' of the Test Schedule. Adjust, if necessary, by means of the phasing shims beneath the barrel/delivery valve assembly (fig. 61), reducing shim thickness to rectify late closure, and vice versa. Pumps with serial numbers prefixed '626' and later have two-piece shims which can be changed without removing the barrel/delivery valve assembly. Variation of shim thickness affects the dial reading by a corresponding amount. When correct, leave camshaft at No. 1 port closure and set the pointer of the graduated disc on the pump drive to a convenient figure, noting this for reference during phasing.
- (vi) Remove measuring rig 1 688 130 085, together with its gauge, and refit the blanking plug (fig. 59, Item 'A').

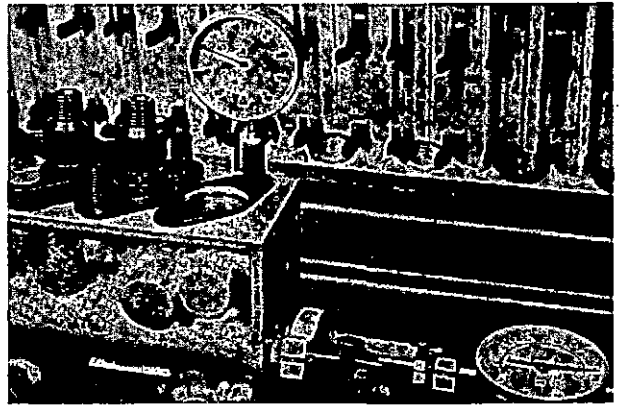

Fig. 61 Adjusting thickness of phasing shims

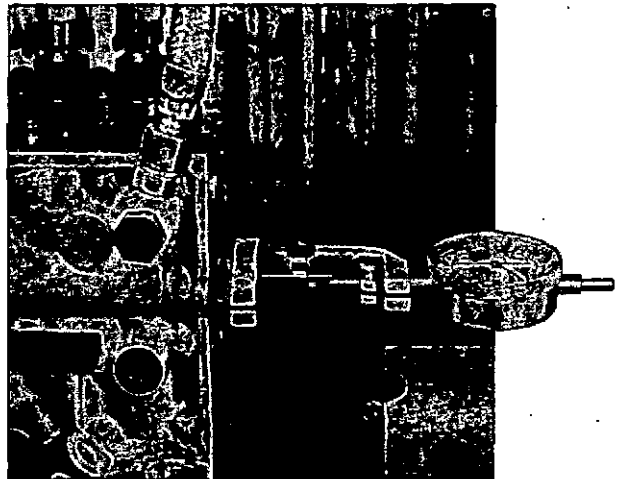

Fig. 62 Measuring rack travel

2. Phasing

Turning the camshaft in direction of rotation, check the port closures of the remaining elements in sequence order (viz: 4, 2, 6, 3, 5, in multiples of 60 degrees), using No. 1 as a datum in each case. Correct any element found beyond limits (± 0.5 deg.) by means of its phasing shims as described earlier. Note that if barrel/delivery valve assemblies are disturbed they should be reset at mid-slot position when their securing nuts are tightened after phasing, thus providing calibration adjustment in either direction.

3. Calibrating

- (i) Remove the blanking plug fitted to the LP relief valve tapping for pre-stroke setting and substitute overflow valve 1 417 413 025, connecting its outlet pipe to the test bench oil return system. Set test oil supply pressure to 22lbf./sq. inch (152 kN/sq.m).

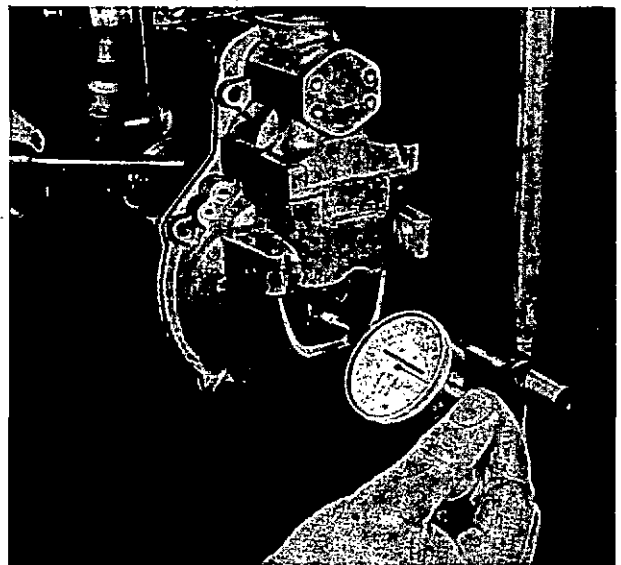

Fig. 63 Measuring sliding sleeve travel

- (ii) Remove the excess fuel device (or smoke stop, as applicable) and fit the rack travel measuring rig 1 688 130 030, together with its dial gauge 1 687 233 015, as shown in fig. 62. With the control rack in the STOP position, zero the dial gauge and tighten the clamping screws. Ensure that the rack can travel its full range of approximately 21 mm.
- (iii) Referring to Stage 'A' of the appropriate Test Schedule, run the pump at 600 r.p.m. and measure the rack travel and the delivery from each element. These should conform to the figures in heavy type at the head of Columns 2 and 3 of the Table under 'Calibrating'. The spread should not exceed the figure quoted in Column 4. Correct errors on individual elements as necessary by rotating their flange bushings within the limits of the adjusting slots, using open ring spanner 1 687 950 525. On completion, tighten the flange bushing nuts to between 29 and 32 lbf.ft. (39 and 44 Nm). Carry out the remaining tests in the Table in Stage 'A'. In each case the delivery from every element should conform to the limits quoted, and failure to do so indicates a faulty element which should be renewed.

STAGE 'B' — GOVERNOR SETTING

1. Setting sliding sleeve travel

Note: The sliding sleeve consists of the slider and the adjusting pin, as an assembly (Items 'E' and 'F' respectively in fig. 46).

- (i) For protection, a cutaway rear cover should be fitted whilst this operation is carried out. Mount the measuring rig 1 688 130 095, attaching the magnetic base of the dial gauge to the slider. With the pump stationary, pre-load the gauge approximately 20 mm; at the same time take up any play in the governor mechanism by lightly pulling on the gauge spindle as shown.
- (ii) Referring to Stage 'B' of the appropriate Test Schedule, carry out test running as specified in Columns 10 and 11 of the Table, working to the upper limit where possible. Make corrections by equal adjustment of the flyweight spring retaining nuts; a difference of one notch between them is permissible. Turning the nuts clockwise reduces sleeve travel, and vice versa.
- (iii) Fit the permanent rear cover. Refer to Part 3 'GOVERNOR', under 'Assembling'. Item 8, for details of this operation.

2. Checking run-out characteristics

- (i) Remove the speed control lever, reverse it and refit it in the same relative position.
- (ii) Attach the setting rig 0 681 440 006 as shown in fig. 64. Note that the rack travel measuring rig used in Stage 'A' is still fitted.
- (iii) Referring to Stage 'B' of the appropriate Test Schedule, set the control lever to the basic angle specified in Col. 1 of the Table. Run the pump at the speed specified at the top of Col. 2, measure the rack travel and compare it with the limits at the top of Col. 3. If correction is necessary, use the following three methods in sequence order until successful:
 - (a) Vary the basic settings of the control lever within the limits of ± 3 degrees.
 - (b) Alter the setting of the adjusting pin (figs. 52 and 54). Turning the bearing bolt one half-turn clockwise reduces rack travel approximately 2.25 mm., and vice versa.
 - (c) Vary the thickness of the shims beneath the (S) plate (fig. 57). Reducing shim thickness by 0.15 mm. reduces rack travel approximately 1 mm., and vice versa.
 - (iv) Leave the control lever set as at the completion of (iii) above and carry out the subsequent tests in Cols. 2 and 3.
 - (v) Carry out similar tests as detailed in Cols. 4 to 6 and 7 to 9 respectively. For each of these tests, correction may be made by varying the basic setting of the control lever within the limits of ± 3 degrees to bring rack travel within limits.

STAGE 'C' — FINAL SETTING

1. Setting MAX. FUEL stop

- (i) Remove the rack travel measuring rig 1 688 130 095, together with its dial gauge, and fit the excess fuel device or smoke stop, as applicable.
- (ii) Referring to Stage 'C' of the appropriate Test Schedule, run the pump at the speed quoted in the first column of the Table and measure the fuel delivery from each element. Compare the results with the fuelling figure shown on the Rolls-Royce data plate affixed to the side of the governor. Adjust, if necessary, by altering the setting of the rack stop. Referring to fig. 59, remove the cover 'B', slacken locknut and screw the stop clockwise to reduce fuelling, or vice versa as required.
- (iii) On completion, tighten the locknut and refit the cover.

2. Governor break-away

- (i) Remove the speed control lever (reversed during Stage 'B') and refit it in its normal position.
- (ii) Remove the rack access plate on the governor rear face (fig. 44, Item 'A') and mount a dial gauge with its button resting on the rack extension. If necessary a bolt may be fitted to the tapping in the extension to facilitate this. Pre-load and zero the gauge.
- (iii) Set the control lever on the MAX. FUEL stop (fig. 65, Item 'B'). Referring to the Table in Stage 'C' of the appropriate Test Schedule, run the pump and note the speed at which the rack commences to move, as indicated by the dial gauge. This speed should be between the two quoted in Col. 3. If the speed recorded is incorrect, extract the lead seal, (fig. 65, Item 'A'), remove the cover screw beneath it and adjust the MAX. SPEED stop 'B' as necessary. Screw the stop clockwise to increase speed, and vice

versa. On completion, tighten the stop locknut, refit its cover, and replace the rack access plate.

3. Excess fuel

Referring to Stage 'C' of the appropriate Test Schedule, depress the EXCESS FUEL lever, run the pump at the speed specified in the Table and check that fuel delivery is within the limits quoted.

4. Idling

Adjust the stop (fig. 61, Item 'C') to give fuelling of 2 ccs. per 100 strokes at 325 r.p.m. Final adjustment is made on the engines at installation.

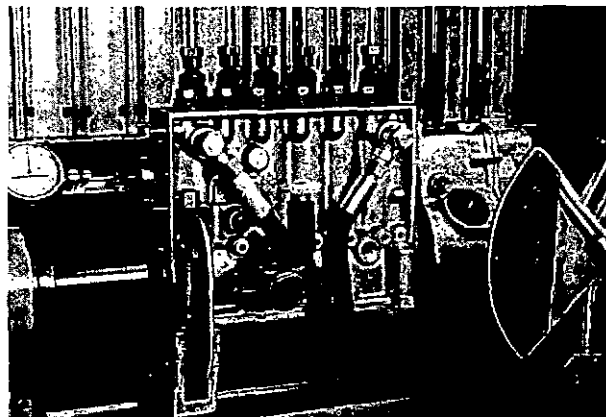

Fig. 64 Checking governor run-out



Fig. 65 Control lever stops and seal

TEST SCHEDULE

Engine specification: Rolls-Royce C6 200G
Injection pump: PE6P 120A 320RS 3042
Injection pressure: 175 ats

Governor: RQV 350/650-750 PA 386R
Test oil temperature: 40 deg. C (140 deg. F)
Feed pressure: 22 lbf./sq. inch (152 kN/sq.m).

A. Fuel Injection Pump Settings

Port closing at prestroke — 3.40 to 3.50 mm (from BDC)

Rotational speed rev/min	Control rod travel mm	Fuel delivery 'cm'/100 strokes	Difference 'cm'/100 strokes
720	14.3 +0.1	32.1 to 32.5	0.5 (0.8)
350	4.3 to 4.5	1.6 to 2.0	0.4 (0.7)

B Governor Settings

Upper rated speed			Intermediate rated speed			Lower rated speed		
Degree of deflection of control lever	rev/min Control rod travel mm	Control rod travel mm rev/min	Degree of deflection of control lever	rev/min	Control rod travel mm	Degree of deflection of control lever	rev/min	Control rod travel mm
ca. 68	730 900	15, 2—17, 8 0—1	ca. 38	675-685 715-745	13,8 4,0	ca. 12	100 350	4, 3-4, 5 645-705=2,0
ca. 65	13,8 4,0	750-755 775-785						

C: Settings for Fuel Injection Pump with Fitted Governor

Full load delivery		Rotational speed	Fuel delivery characteristics		Starting fuel delivery	
Control rod stop	Test oil temp 40° C (104F)	limitation	High idle speed		idle switching point	
rev/min	cm/1000 strokes	rev/min	rev/min	cm/1000 strokes	rev/min	cm/1000 strokes
720	321,0-325,0 (318,0-328,0)	750-755			100 350	17-18 mm RW 16-20

PART 6 — AMBAC GOVERNING

DESCRIPTION

The modular designed Ambac governor is offered as an alternative on all 'C-RH' engines.

The system consists of a magnetic pickup, electronic control unit, a frequency trim potentiometer, and an electromagnetic actuator. The actuator and pickup are engine mounted with the other accessories located in a suitable position. A fast system response is obtainable over a broad range and the various elements of the system are easily replaced if necessary.

ASSEMBLING (Fig. 66 and Fig. 67)

The following sequence must be strictly adhered to when the unit is being assembled to the fuel pump.

1. Secure the bellows (3) to the outside ring at the pump rack using the clamp (4).
2. With holding screws (5) and lock washers secure the rack connector link (14) in position.
3. Fit the other side of bellows (3) to the rack connecting link (14) and secure with clamp (4).
4. Remove loose cover (11) and gasket (10).

5. Fit 'O' ring (6) to the housing.
6. Back off the spacer adjusting screws (7).
7. Place the gasket (1) in position and secure the governor unit to the pump using mounting screws (9 and 15) together with lockwashers (8 and 2).
8. Remove one hexagon screw (9) and bring adjusting spacer (7) against the surface in pump cover. Refit hexagon screw and torque to 80 to 97 lbf.in. (9 to 11 Nm). Repeat this operation with the remaining hexagon screw.
9. Check the tightness of all four mounting screws to a torque loading of 80 to 97 lbf.in. (9 to 11 Nm).
10. Position the rod and bearing (12) to allow armature travel of 1 to 4 mm when the rack is fully in towards pump.
11. Assemble spring (20) and bracket in position and secure with screw (17) and locknut (18) to the rack connecting link (14) and rod end bearing (12). Bracket must be free on spring retaining pin.
12. Hold the stop lever (16) against stop in housing with the rack in the extreme position towards pump. Turn the adjusting screw until it makes contact with the lever (16) and then back off screw approximately one full turn.
13. Fit cover (11) and gasket (10) to the housing.
14. The top two cover securing screws have provision for a lock-wiring seal.

Printed in Great Britain

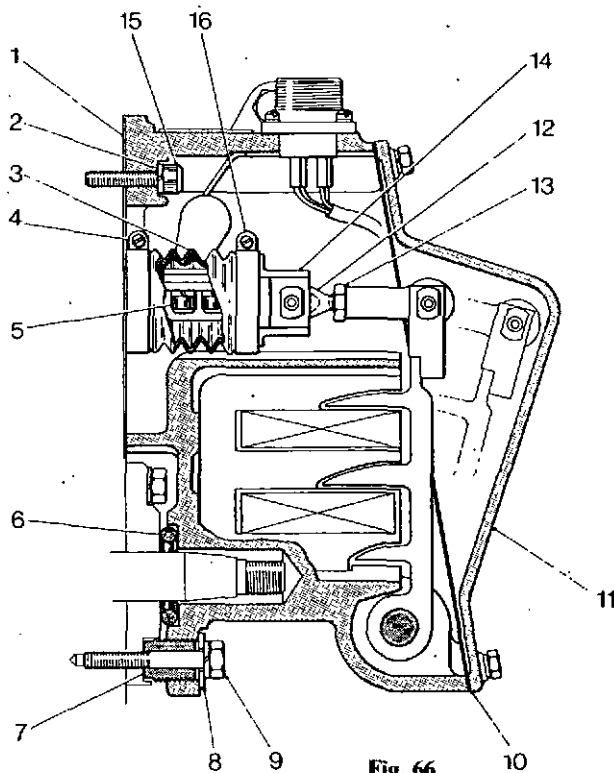

Fig. 66

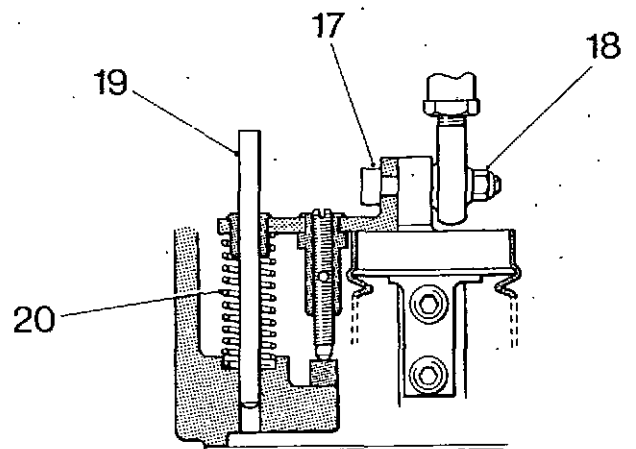

Fig. 67

ELECTRIC FAULT DIAGNOSIS

If the governor does not operate, measuring, in sequence, voltage between the various control unit terminals and ground (Terminals F, G, H and T are ground) will indicate the possible fault. Should all 5 Voltage tests indicate normal values, the defect must be in the actuator or in the wiring to the actuator.

TERMINALS	NORMAL VALUE	PROBABLE CAUSE OF NON-NORMAL READING
S	1.0 volt AC-RMS minimum while cranking.	<ol style="list-style-type: none"> 1. Defective magnetic pick up. 2. Gap too large between pickup and gear teeth. 3. Improper or defective wiring to the pickup.
K	10.1 ± .20 volts DC while energized (Internal regulated D.C. D.C. supply).	<ol style="list-style-type: none"> 1. D.C. power not connected or low battery voltage. 2. Frequency trim potentiometer shorted, ground or mis-wired. 3. Wiring error. 4. Defective control unit.
L	<p>Above 5.1 volts D.C. while cranking. (Inverse speed error signal).</p> <p>Above 5.1 volts is under speed signal. Below 5.1 volts is over speed signal.</p> <p>On speed will indicate a steady 5.1 volts.</p>	<ol style="list-style-type: none"> 1. Frequency adjust set too low. Turn clockwise. 2. Defective control unit.
N	8.5 to 9.5 volts D.C. while cranking. (Proportional actuator voltage).	<ol style="list-style-type: none"> 1. Defective control unit. 2. Battery voltage may be too low while cranking.
B	2.5 volts D.C. maximum while cranking. (Transistor voltage).	<ol style="list-style-type: none"> 1. Output transistor open (defective control unit). 2. *Defective actuator 3. Error in wiring to actuator.

Continued

FURTHER FAULT TESTS

SYMPTOM	TEST	PROBABLE TROUBLE
Engine overspeeds	Determine voltage on terminal "L". Should be less than 5.1 volts D.C.	<ol style="list-style-type: none"> 1. Frequency set too high. Turn frequency adjust counter-clockwise. 2. Defective control unit.
Engine overspeeds	Measure the voltage across the insulated nut located on the side of the control unit. Should be more than 2.5 volts D.C.	<ol style="list-style-type: none"> 1. Output transistor shorted (Defective control unit). 2. Wiring to actuator incorrect.
Rack does not move	Measure battery voltage at the battery while cranking. Must be 8.0 volts D.C. minimum.	<ol style="list-style-type: none"> 1. Insufficient battery voltage. Put a momentary connection from terminal "B" on the control unit to negative ground while cranking (Terminal "G" is ground). 2. Replace with battery of higher amp hour rating.
Rack does not move	Ground the insulated nut located on the side of the control unit. Rack should move to full open position.	<ol style="list-style-type: none"> 1. Wiring to actuator or battery incorrect. 2. Actuator or linkage bound. 3. *Defective actuator.

***DEFECTIVE ACTUATOR**

Should the coils of the actuator become open or shorted, replace the actuator. If the coils are not open or shorted, the wiring or connectors are defective.

**TEST PROCEDURE FOR ROBERT BOSCH FUEL PUMP FITTED
WITH AMBAC INTEGRAL ACTUATOR AGB 250 A1**

Fit fuel pump to test rig in normal manner, with cam box primed with oil and oil holes blanked off.

Connect a 12 or 24- D.C. power supply (as available) to the actuator, as shown on fig. 68 (a) or (b). With voltage supplied the pump should deliver full fuel when driven, and the standard pump calibration checks can be undertaken; refer to standard test procedure.

On completion of calibration tests, the power supply should be disconnected with the pump still being driven at rated speed. Fuel delivery should cease immediately the power is disconnected.

The pump should return to full fuel delivery when voltage is re-applied to the actuator, and should cease immediately when the stop lever is moved by hand to the stop position.

If any governor malfunctions are indicated by the above tests, they must be rectified before returning the pump to the engine.

If NO-D.C. POWER SUPPLY IS AVAILABLE, the governor operation cannot be checked. The pump operation can be checked by the following procedure:

Remove actuator end cover. Push armature (and rack) fully over to the full fuel position, i.e. fully into the pump body. Hold firmly in this position with a strong spring or length of rubber (a used engine wet liner seal ring is ideal).

With the rack held firmly in this position, the fuel pump rig checks can be performed, as laid down in the standard test procedure.

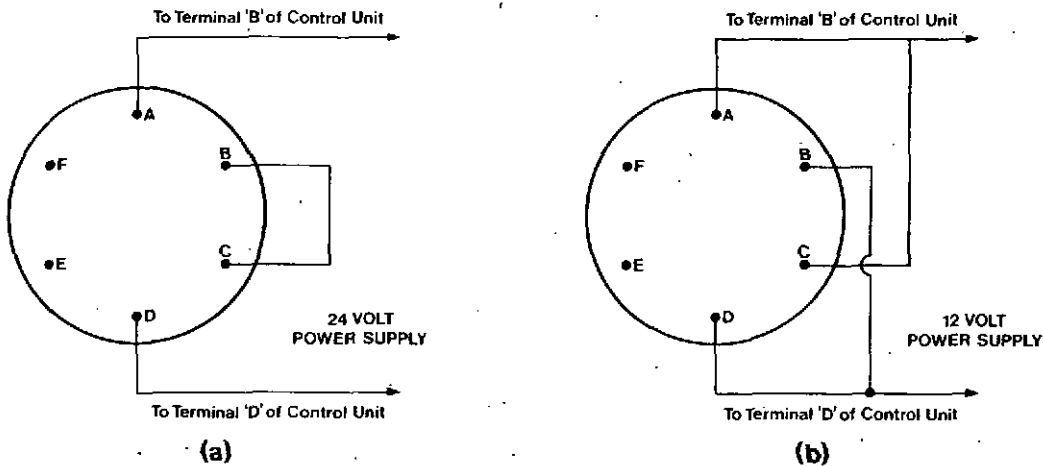

Fig. 68

SECTION 11—LUBRICATION SYSTEM

DESCRIPTION

The system illustrated in figs. 1 and 2 is diagrammatically correct for 'C-RH' engines, but certain components may be differently situated to suit individual installations, e.g. the sump pannier and relief valve may be at front or rear, and the position of filler cap and dipstick will vary.

Engines fitted with rear-drop sump

Approximately 6.5 gallons (29.5 litres) of engine oil is carried in the cast aluminium sump which has a steel insert screwed, sealed and pinned into the pannier base. The insert carries a hexagonal drain plug which is tightened to between 80 and 85 lbf.ft (110 to 115 Nm) and wire locked to it. Maximum and minimum oil levels are indicated by two lines on the dipstick, the difference being approximately 2.5 gallons (11.3 litres).

Engines fitted with forward-drop sump

The forward-drop sump is similar in make-up to the rear-drop sump but has a smaller oil carrying capacity of approximately 5.5 gallons (25 litres). Maximum and minimum oil levels are marked on the dipstick, the difference between marks being approximately 1.5 gallons (6.8 litres).

A spur-gear pump mounted on the front main bearing cap and gear-driven from the front of the crankshaft, draws oil through a filter in the sump pannier and circulates it under pressure throughout the system. After circulation the oil returns to the sump by gravity, external drain pipes being provided for the turbocharger (if fitted) and the injection pump/governor assembly.

On leaving the pump the oil passes through gallery pipes to a spring-loaded relief valve, carried in a casting bolted to the exterior of the sump. This valve controls pressure at 50 to 70 lbf./sq. inch (345 to 483 kN/sq.m) and returns surplus oil to the sump. The oil then enters the heat exchanger at its rear end and passes six times over the tube pack before leaving at the front and entering the parallel-flow filters.

Two by-pass valves, one above each filter bowl, are carried in the filter header to prevent oil starvation if the filters become choked. A tapping for the turbo-charger supply is taken from the rear of the header, on the 'clean' side of the filters.

On leaving the filter header the oil returns to the relief valve casting, where a tapping is taken for the pressure gauge, and then enters a gallery supplying each main bearing. The crankshaft is drilled for big-end lubrication, each crankpin embodying a sludge trap with detachable plug. The big-end bearings are grooved to provide a continuous flow of oil through the drilled connecting rods to the small-end bearings; two drillings in the small-end eyes supply jets of cooling oil to the undercrown areas of the piston.

Oil from the centre main bearing passes through a drilling to the camshaft centre bearing, where it enters the hollow camshaft and emerges from a drilling at each journal. A cross-drilling at the front of the crankcase carries oil from the camshaft front bearing to the idler gear axle and to an external connection for the injection pump oil supply.

A drilling upwards from the camshaft centre bearing into the tappet chest is connected to a gallery which supplies oil, through further drillings in the cylinder block, to an oilway stud passing through each cylinder head. This oil, at reduced pressure due to a restrictor drilling in the stud (see Section 3, fig. 11), enters the hollow rocker shafts to lubricate the rocker bearings and passes through drillings in the rocker arms to the pushrod ends and valve tips. (See Section 8 CYLINDER HEADS).

LUBRICATING OIL

Use only a lubricating oil to the grade and viscosity approved by Rolls-Royce for the engine (see leaflet T.S.D. 3085 in the pocket at the back of this Manual). Change the oil and service the filters in accordance with the Servicing Schedule given in the Servicing Manual T.S.D. 3126, Operator's Guide T.S.D. 3124 and Wall Chart T.S.D. 3133.

**KEY TO FIG. 1—LUBRICATION SYSTEM—OIL FLOW THROUGH
MAIN ENGINE**

- | | |
|----------------------------------|--------------|
| 1. Suction filter | |
| 2. Pressure pump | |
| 3. Oil pressure relief valve | |
| 4. Oil-to-coolant heat exchanger | } See fig. 2 |
| 5. Parallel-flow main filters | |
| 6. Piston cooling jets | |
| 7. Supply to air compressor | |
| 8. Supply to injection pump | |
| 9. Idler gear axle | |
-
- | |
|---|
| A — High pressure system |
| B — Restricted flow system |
| C — Suction, spill and splash lubrication |
| D — Crankshaft oilways |

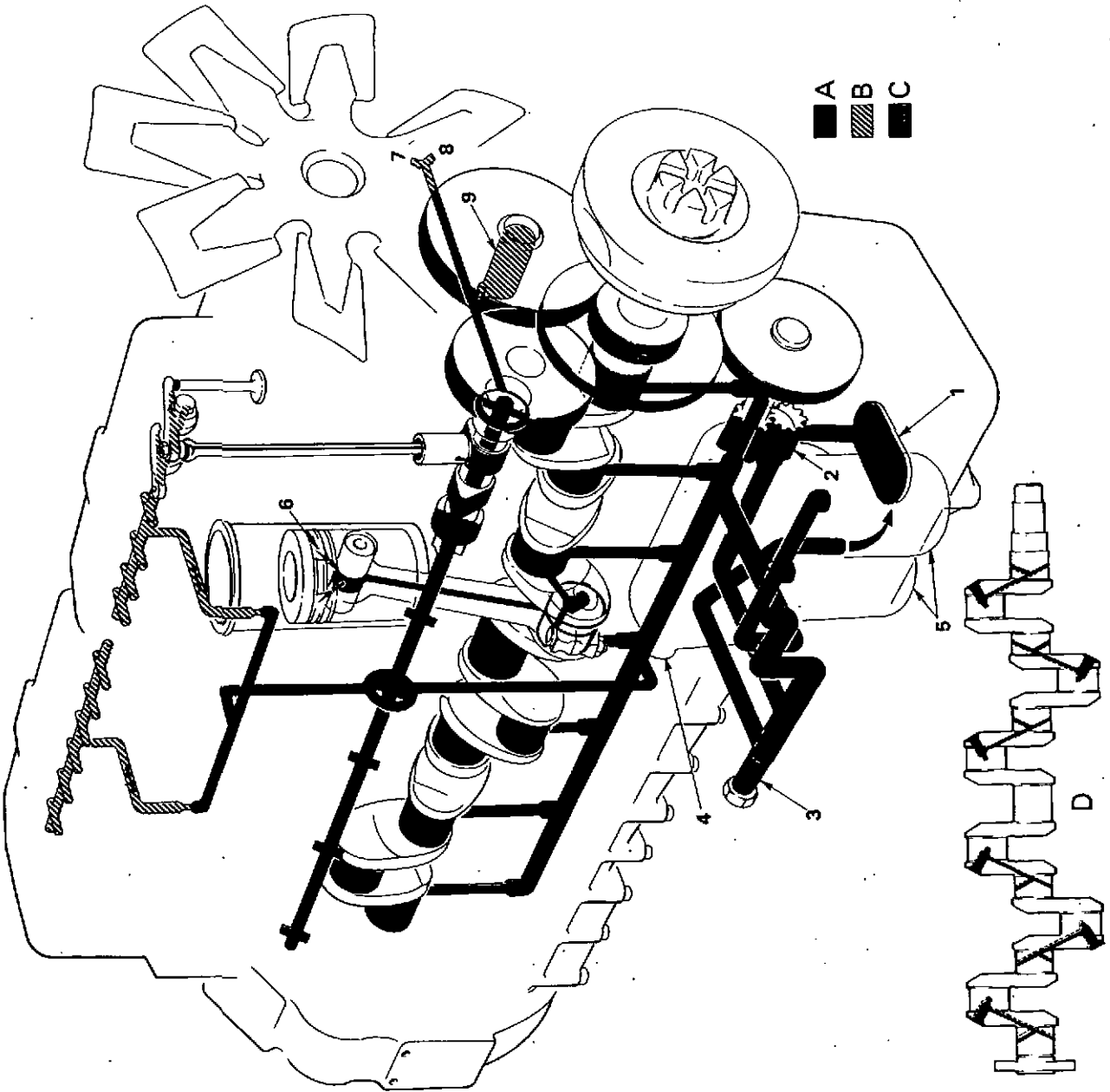

24798A

Fig. 1 Lubrication system—oil flow through main engine

KEY TO FIG. 2—LUBRICATION SYSTEM—OIL FLOW THROUGH RELIEF

VALVE, HEAT EXCHANGER AND FILTERS

1. Relief valve spill to sump
 2. Oil supply from pump
 3. Oil inlet to heat exchanger
 4. Oil exit to filter header
 5. Filter by-pass valves
 6. Turbocharger supply (if applicable)
 7. Pressure gauge connection
 8. Delivery to main bearings
 9. Tube pack locating screws
- A — Unfiltered oil from pump
B — Relief valve spill to sump
C — Filtered oil to engine

24797A

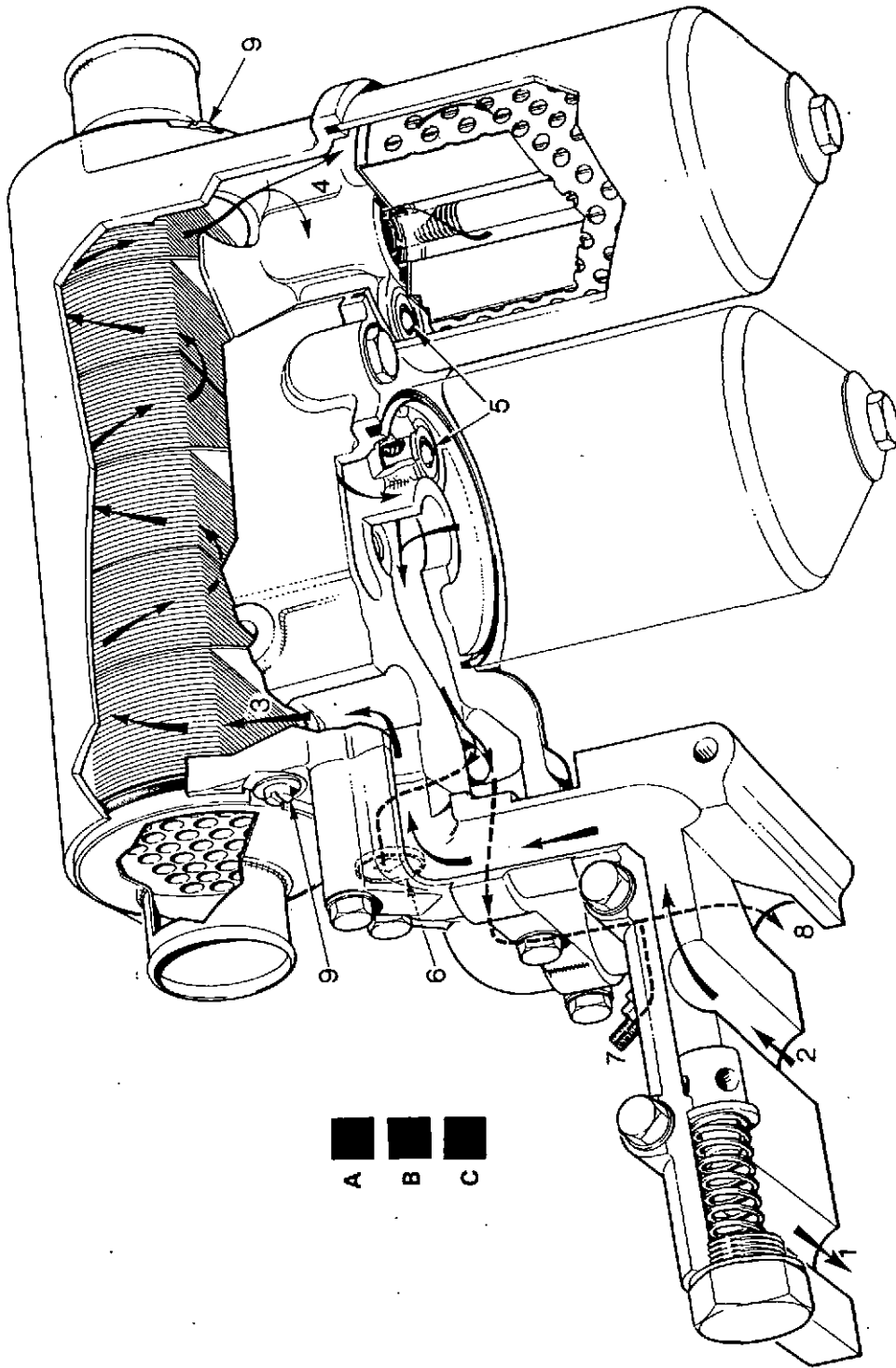

Fig. 2 Lubrication system—oil flow through relief valve, heat exchanger and filters

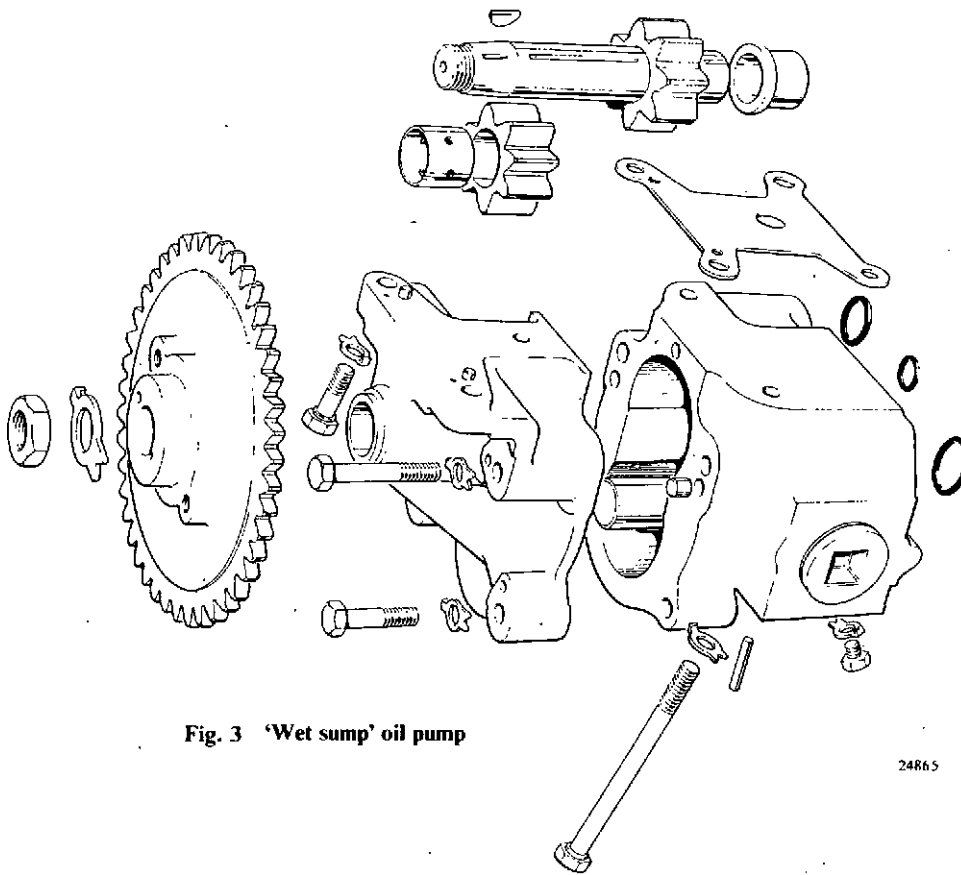

Fig. 3 'Wet sump' oil pump

24865

OIL PUMP

Dismantling

Unlock and unscrew the pinion nut, and withdraw the pinion, using extractor GA.7. Remove the pump casing setbolts and dismantle the unit (fig. 3), keeping mated components together.

Inspection

Thoroughly clean all components. Inspect casings, gears and bearings for wear and damage. Remove any small burrs by careful stoning, and polish out any slight scoring. If possible, carry out a crack test on the gears and pinion.

Scoring or wear on the inner face of the front cover may be removed by machining a maximum of 0.010 inch (0.25 mm.) from the surface, taking care to keep the face square with the bearing bore. Any other unserviceability of the casing halves or the driven gear spindle will involve renewal of the pump casing.

Check the diametral clearance and end float of the gears in the casing, and the fit of the spindles in their bearings.

Assembling

Oil the parts and assemble the pump as shown in fig. 3, ensuring that the casing joint faces are perfectly clean and dry; no jointing compound is used. Before fully tightening the casing setbolts, check by straight-edge that the pump-mounting faces are aligned with one another. After tightening, check that the drive-shaft can be turned easily by hand. The pump drivegear is fitted after the pump has been assembled to the engine, so that its securing nut may be tightened to 50 lbf.ft. (70 Nm). Note that the pump is dowelled to the front main bearing cap and that drivegear backlash is adjustable by shims (see Section 3, Item 16).

Provided that the fits and clearances of pump components conform to the limits quoted in the Schedule at the end of this Section, the performance of the pump will be adequate and no rig test is necessary.

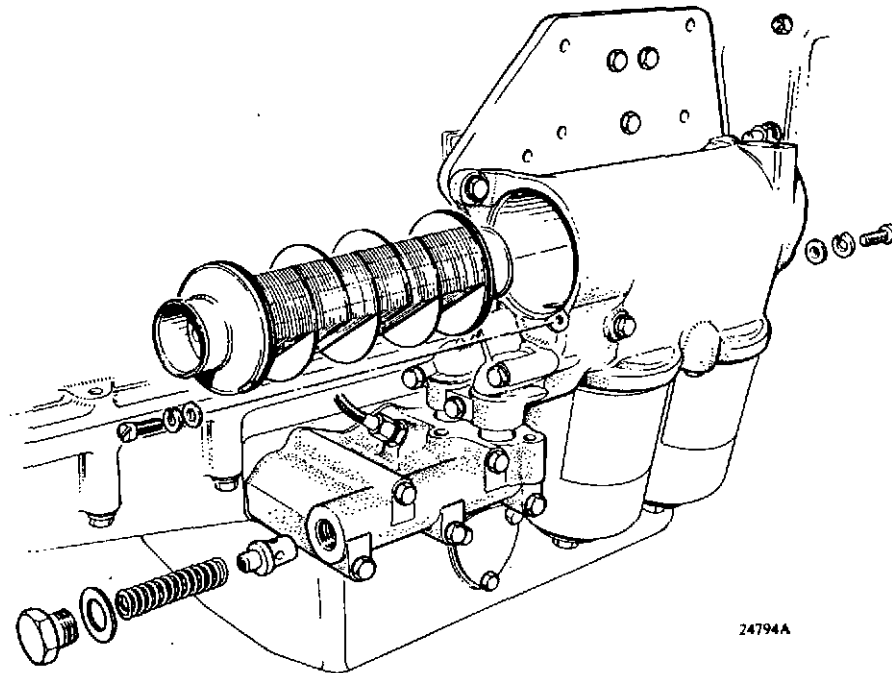

Fig. 4 Relief valve and heat exchanger—exploded

OIL PRESSURE RELIEF VALVE

The valve assembly (fig. 4) is bolted to the sump panner at front or rear of the engine, dependent on installation requirements. It consists of a non-adjustable spring-loaded plunger in a casting which is directly connected to the pressure pump outlet. Pressure in excess of approximately 60 lbf./sq. inch (414 kN/sq.m) causes the plunger to move against its spring, uncovering ports by which surplus oil is returned to the sump.

Dismantling

Unscrew the capnut and withdraw the spring. Extract the plunger from its bore, using tool GA.14 or a 2BA bolt screwed into the tapping in the plunger stem. The latest plunger has no tapping and may be withdrawn by means of a piece of close-fitting rubber or plastic tubing forced over the stem.

Inspection

Examine the plunger and its bore in the casting, and reject them if deeply scored. Check that the plunger slides freely without being loose in the bore. Slight burrs may be stoned out.

Two types of plunger may be encountered, the earlier type having a small conical seating above the cylindrical body; on the later type this seating is deleted and the new version of this type has no extractor tapping, as previously described. All plungers are fully interchangeable.

Inspect the spring for wear and distortion. A new spring conforms to the following requirements:

Free length: 2.54 inches (64.6 mm.)

Length under 26 lb. (12 kg.) load: 1.65 ins. (42 mm.)

Reassembling

When reassembling the unit, fit a new aluminium washer, 0.036 inch (0.9 mm.) thick, under the spring capnut, otherwise the setting of the valve will be altered.

OIL-TO-COOLANT HEAT EXCHANGER

The unit (figs. 2 and 4) consists of a finned tube pack in a housing which also forms the oil filter header. Coolant from the radiator outlet passes through the tube bores, and lubricating oil at controlled pressure from the pump enters through a port at the rear of the housing and flows over the exterior of the pack.

Baffle plates on the tube pack direct the oil six times across the tubes before it enters the oil filter header via a port at the forward end.

On most engines the tube pack is reversible in the housing, the exception being where a hose connection is at an angle to suit a particular installation. Location of the baffle plates to the inlet and outlet ports is ensured by a 2BA screw and washers engaged in a machined recess at each end. A rubber 'O' ring in a groove at each end of the tube pack forms an oil seal within the housing bore.

Dismantling and cleaning

1. Drain the coolant, disconnect the coolant hoses and lubricating oil pipes from the unit, unscrew the four setbolts which secure the unit to its mounting plate and lift it away. Remove the filter bowls.
2. Unscrew the 2BA screw from each end of the housing and push the tube pack forward so that the front 'O' ring can be removed. Then withdraw the pack rearward (fig. 4). Do NOT attempt to push an 'O' ring through the housing, since it could foul an oilway port and cause the pack to become jammed.

Note: If pressure is necessary to move the pack, it must not be applied to the sheet metal ends. Use a medium-soft wooden dolly of round section, applying the end-grain to the ends of the tubes. After using this method, always check that the tube bores are clear and undamaged.
3. Wash the tube pack in paraffin, taking care not to damage the fins, blow through the tubes with compressed air, and wash the pack in hot water.
4. Hard deposits in the tube bores may be loosened by soaking the pack in a solution of 1 part inhibited hydrochloric acid to 3 parts of fresh water. When frothing ceases, immerse the pack in a solution of washing soda (sodium carbonate) in hot water, 1 lb. to 5 gallons (0.5 kg. to 25 litres). Finally, blow through the tube bores with an air jet and wash the pack in hot fresh water.

Inspecting and reassembling

1. Inspect the pack for corrosion, cracks and damage, and if possible make a pressure test by

applying air at 30 lbf./sq. inch (210 kN/sq.m) to the tube bores with the pack immersed in water at 176°F (80°C).

2. Assemble the tube pack to its housing in the following sequence to avoid damaging the 'O' rings by contact with the edges of the housing ports. *See Note in Operation 2 under 'Dismantling and Cleaning' concerning use of pressure on the tube pack.*
 - (a) Ensure that the housing bore is perfectly clean and free from burrs. Apply a light smear of rubber grease or engine oil to the bore at both ends.
 - (b) Insert the tube pack, without 'O' rings, at the rear of the housing, and align the machined recesses for the locating screws. Push the pack into the housing until the 'O' ring groove *just* emerges at the front.
 - (c) Fit the front 'O' ring, lightly lubricated, and carefully pull the tube pack backwards until the rear 'O' ring groove *is just* exposed.
 - (d) Fit the rear 'O' ring, lightly lubricated, and push the pack into its correct position in the housing. Check that the tube bores are clear and undamaged.
 - (e) Fit a locating screw, with spring and plain washer, at each end of the housing. Refit the filter bowls, with new elements.
3. Refit the unit to the engine in the reverse sequence of Operation 1 under 'Dismantling and cleaning', using new hoses and joints.

MAIN FILTERS AND BY-PASS VALVES

Two filters, in parallel, are mounted on a header incorporated in the oil-to-coolant heat exchanger, which is bolted to a plate on the right-hand side of the crankcase at sump level.

Each filter bowl (fig. 5) houses an expendable element and is secured to the header by a central fixing bolt. A by-pass valve is carried in the header above each filter.

Filter servicing

Remove the bowls by unscrewing their central bolts. Discard the elements and clean the bowl components. Fit new elements and joint rings, fill the bowls with clean engine oil and reassemble them to the header, tightening the central bolts to 20 lbf. ft. (27 Nm).

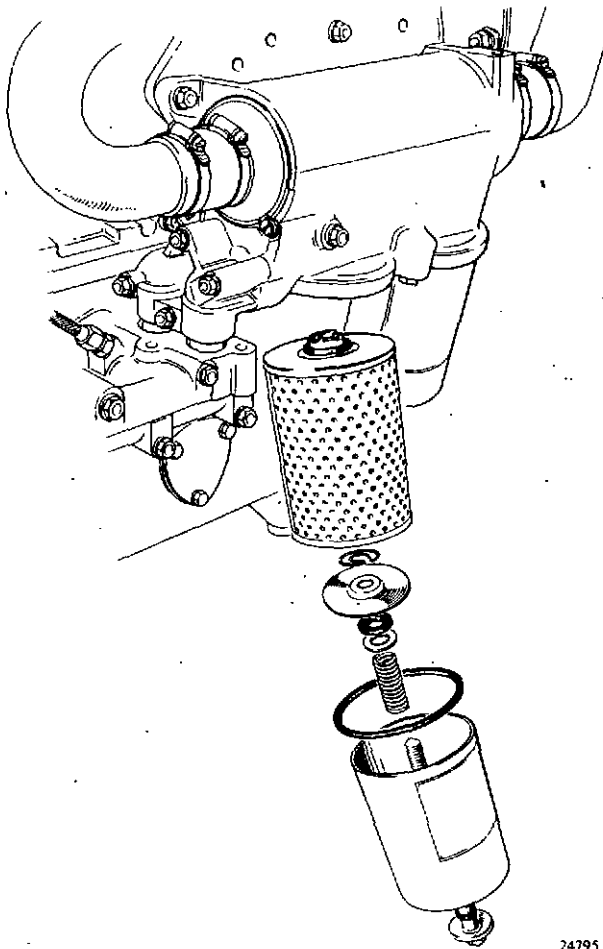

Fig. 5 Oil filters—one assembly exploded

24795

WARNING: Use *only* genuine Rolls-Royce elements, which are guaranteed to conform to Rolls-Royce Specification. These elements are clearly marked "ROLLS-ROYCE GENUINE OIL FILTER REPLACEMENT", followed by the Rolls-Royce Part Number, and each is sealed in a plastic bag. The use of other elements, which do not conform to Rolls-Royce Specification, will involve risking engine damage and may also invalidate the Rolls-Royce Guarantee.

By-pass valves

The two spring-loaded ball valves are non-adjustable sealed units, peened into their housings in the header (see fig. 2). No servicing is required. Either valve will open when its filter element becomes choked to the extent that the pressure drop across it exceeds 15 lbf./sq. inch (103 kN/sq.m) and in these circumstances prevents oil starvation by allowing unfiltered oil to pass to the engine.

OIL GALLERIES

Instructions and illustrations concerning the oil galleries in crankcase and sump, and details for carrying out a pressure test of the lubrication system, are given in Section 3 "Assembling the engine".

SPECIAL TOOLS

- GA.7 Extractor, oil pump drivegear.
- GA.14 Extractor, relief valve plunger.

Printed in Great Britain

FITS AND CLEARANCES

OIL PUMP—WET SUMP

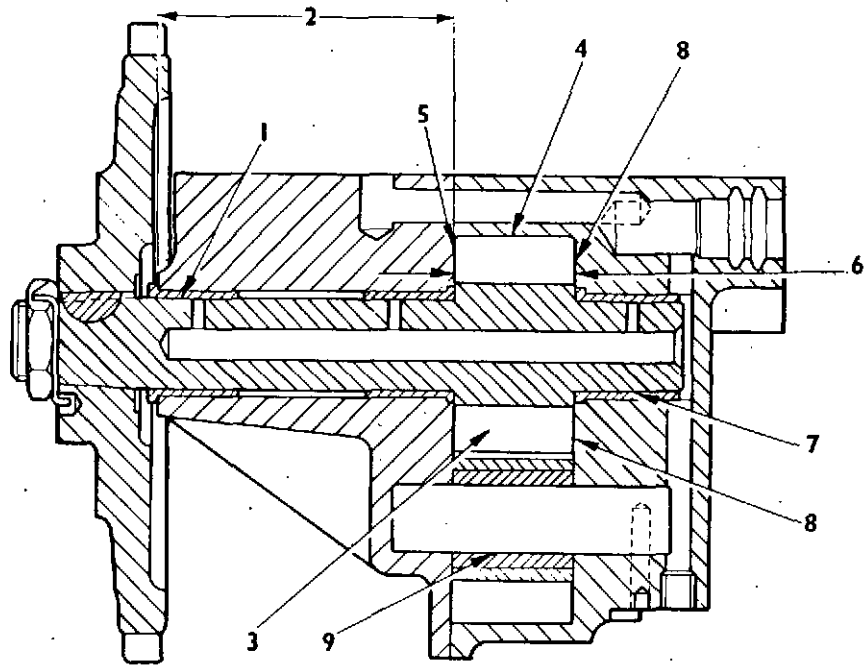

24866

No. ON DIAG.	DESCRIPTION	DIMENSIONS NEW		PERMISSIBLE WORN DIMENSIONS		CLEARANCE NEW		PERMISSIBLE WORN CLEARANCE		REMARKS
		in.	mm.	in.	mm.	in.	mm.	in.	mm.	
1	DRIVING GEARSHAFT IN FRONT COVER Gearshaft in bush Bush — bore	0.875 to 0.8755	22.22 to 22.24			0.0015 to 0.0025	0.038 to 0.063	0.005	0.13	
	Gearshaft — dia.	0.873 to 0.8735	22.17 to 22.19							
2	SCORING ON FRONT COVER Thickness of cover	2.890 to 2.900	73.41 to 73.66	2.880	73.15					Relap minus 0.010 in. (0.25 mm.) max.
3	DRIVING AND DRIVEN GEARS Backlash					0.004 to 0.010	0.10 to 0.25	0.015	0.38	
4	Diametral clearance					0.010 to 0.012	0.26 to 0.31	0.015	0.38	
5	End float					0.005 to 0.0065	0.13 to 0.16	0.008	0.20	
6	Gear thickness	1.1945 to 1.195	30.34 to 30.35							
7	DRIVING GEARSHAFT IN REAR CASING Gearshaft in bush Bush — bore	0.875 to 0.8755	22.22 to 22.24			0.0015 to 0.0025	0.04 to 0.06	0.005	0.13	
	Gearshaft — dia.	0.873 to 0.8735	22.17 to 22.19							

Continued

ROLLS-ROYCE DIESELS

No. ON DIAG.	DESCRIPTION	DIMENSIONS NEW		PERMISSIBLE WORN DIMENSIONS		CLEARANCE NEW		PERMISSIBLE WORN CLEARANCE		REMARKS
		in.	mm.	in.	mm.	in.	mm.	in.	mm.	
8	REAR CASING INNER FACE Scoring									Scoring must not exceed 0.0015 in. (0.04 mm.) deep and 0.010 in. (0.25 mm.) wide
9	DRIVEN GEAR ON SHAFT Shaft in bush Bush—bore Shaft—dia.	0.6562 to 0.6567 0.655 to 0.6552	16.67 to 16.68 16.637 to 16.643			0.0007 to 0.0015 0.019 to 0.038		0.005 0.127		

SECTION 12—WHEELCASE AND GEARS

DESCRIPTION

The wheelcase assembly is mounted at the front of the engine. It consists of a train of spur gears, driven from the crankshaft pinion and enclosed between a steel backplate and an aluminium cover which carries the crankshaft front oil seal and the idler gear axle support plate. For information on assembling, backlash and endfloat checks, and timing, see Section 3.

The backplate is dowelled to the crankcase; the idler gear axle is dowelled to the backplate. To ensure centralization of the crankshaft front oil seal and idler axle support, the wheelcase cover is located to the backplate by fitted bolts (fig. 1).

A pinion, keyed to the crankshaft nose, drives the camshaft and auxiliary drivegears at half engine speed via an idler gear. A large gearwheel, dowelled to the

Printed in Great Britain

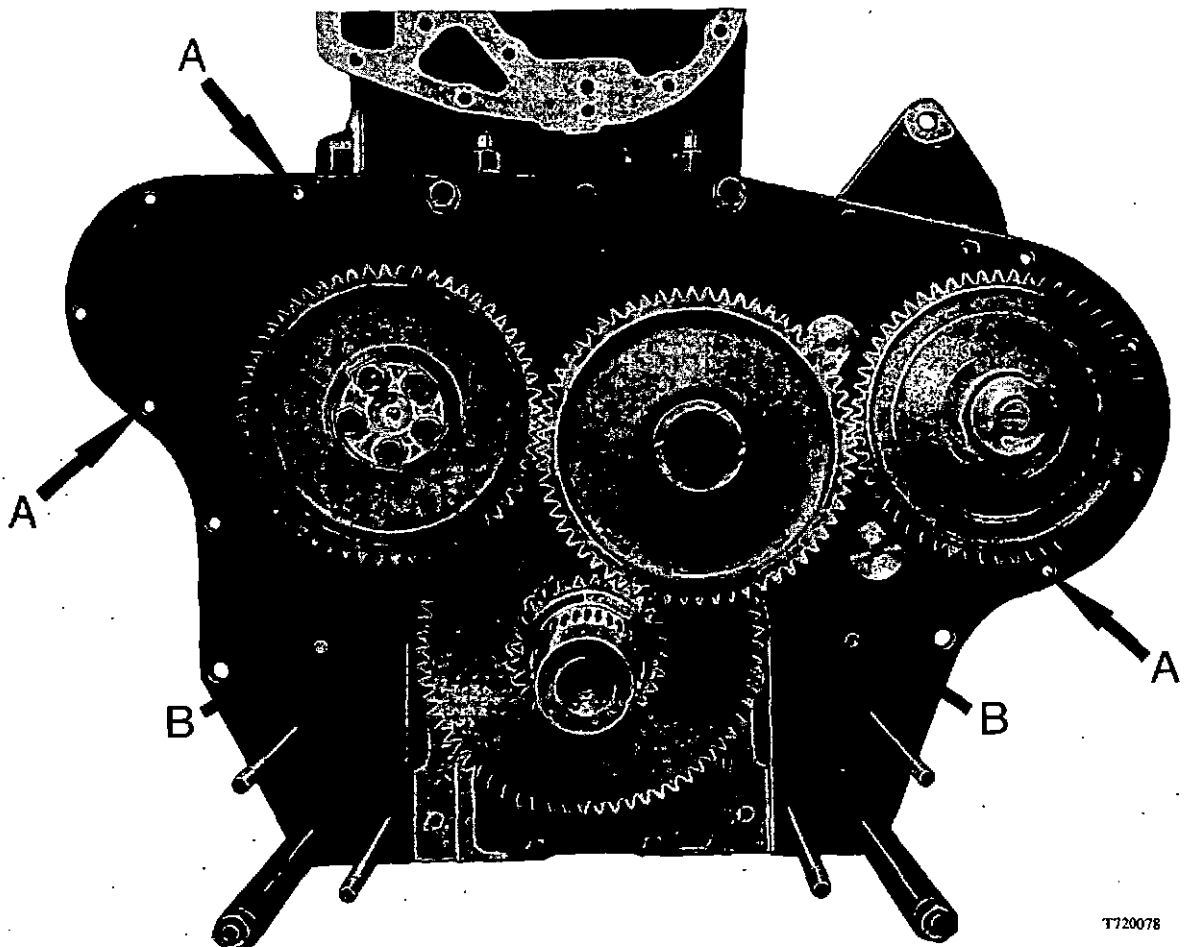

T720078

A FITTED BOLTS—WHEELCASE LOCATION
 B DOWELS—BACKPLATE LOCATION

Fig. 1 Wheelcase and backplate location points

crankshaft behind the pinion, drives the oil pump which is bolted to No. 1 main bearing cap.

Backlash of the gear train, except the oil pump drive, is set during engine build by adjusting the position of the idler gear axle before reaming its dowel holes. Renewal of backplate or axle, which are supplied with undersize dowel holes, will involve repositioning, as described later in this Section; it does not necessarily apply when gears alone are renewed.

Oil pump drivegear backlash is adjusted by shims between pump and No. 1 main bearing cap. See Section 3 under 'Oil pump and gallery' for details.

DISMANTLING

Wheelcase cover

(a) Dismantling from removed engine.

1. Remove the alternator, complete with support bracket and driving belts.

Unscrew the 16 setbolts from the crankshaft hub and remove the barring adaptor, lockplate, damper and pulley. Using spanner OE.44022 and a 4 lb. (1.8 kg.) hammer, unscrew the hub nut (right-hand thread) and withdraw the hub.

3. Remove the sump, if necessary using a $\frac{3}{8}$ inch UNF jacking bolt at each corner to break the joint.
4. Unscrew the nuts and bolts retaining the cover and front mountings, and lift the cover away.

(b) Dismantling from installed engine

1. Remove the alternator bracket and belts, and dismantle the crankshaft hub as described above.
2. Remove the idler axle support plate from the front face of the wheelcase cover.
3. Unscrew the four setbolts securing the front of the sump to the wheelcase cover.
4. Support the engine beneath the sump. Remove the front mountings; unscrew and withdraw their six retaining studs which pass through the wheelcase cover.

5. Remove the remaining bolts securing the cover, carefully separate the joints between the cover, sump and backplate, raise the cover slightly and lift it away.

Gear train

If the camshaft and auxiliary drivegears are to be removed, leave the idler gear in position whilst slackening their retaining bolts and nut. The camshaft drivegear may be tapped off its dowel when the setbolts are removed; see Section 3, fig. 7 for details. To withdraw the auxiliary drivegear, use extractor OE.44409. Details concerning the crankshaft pinion and oil pump drivegear are given in Section 6.

2.365 - 0.002 in. (60.06 - 0.05 mm.)

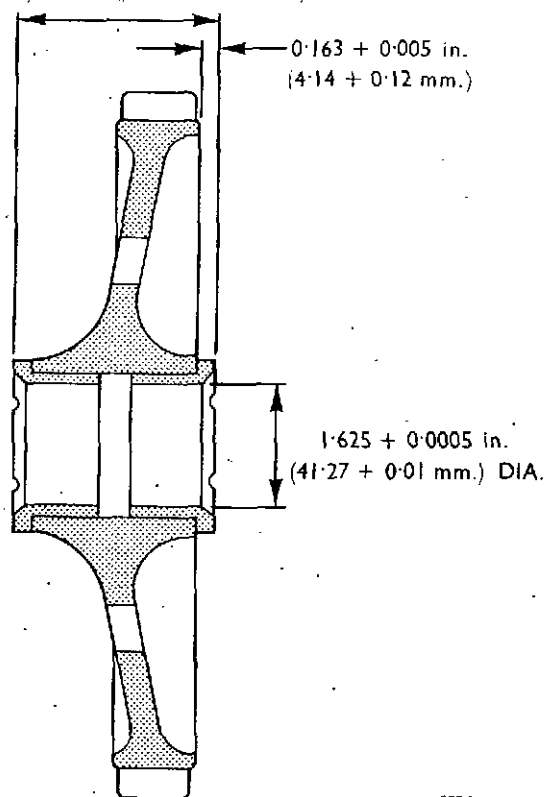

302A

Fig. 2 Dimensions—idler gear bushes

INSPECTION AND REPAIR

Examine all gears for worn or damaged teeth. Wear of the tooth profile is acceptable provided that backlash is within limits and no pitting is evident. Wherever

possible, crack test all gears, using an electro-magnetic method if available.

Examine the wheelcase cover for cracks and damage. Renew the crankshaft front seal, even if apparently serviceable.

Inspect the idler gear bushes and axle for wear. Renew, if necessary, as described later.

Renewing crankshaft front seal

If the wheelcase cover is removed from the engine the seal may be renewed without the use of special tools, as described under 'Wheelcase cover' in Section 3.

For renewing the seal without removing the wheelcase cover from the engine a kit GA.420 is available. Since they locate on the crankshaft nose these tools cannot be used on a dismantled wheelcase.

Remove the crankshaft damper and front hub as described earlier under 'DISMANTLING'. Use extractor GA.364 to withdraw the old seal and tool GA.694 to insert the replacement, lip inwards and lightly packed with Vaseline. Reassemble the front hub and damper as described under 'Crankshaft front end' in Section 3.

Renewing idler gear bushes

Drift out the old bushes. Replacement bushes are supplied with a machining allowance in the bore and whenever possible should be shrunk into position.

Set up the gear on a lathe faceplate so that the finished bore of the bushes will be concentric with the teeth, and machine the bore. Finally, machine the thrust faces of the bushes to ensure correct endfloat. Dimensions are given in fig. 2.

Printed in Great Britain

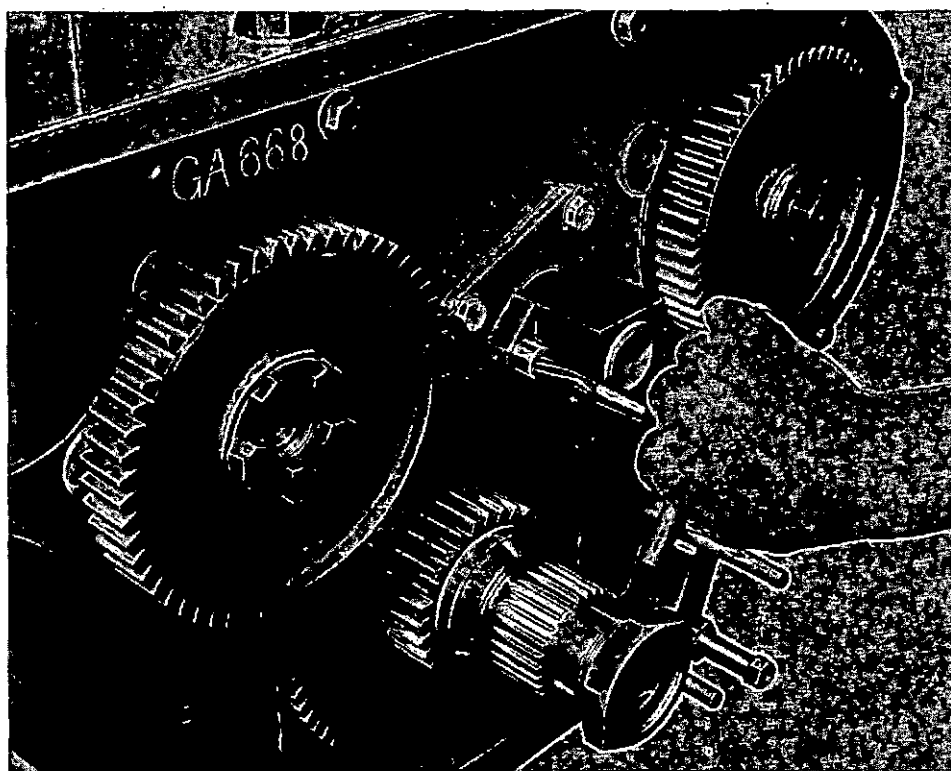

Fig. 3 Reaming dowel holes—idler gear axle

T720060(A)

Repositioning idler gear axle

Backlash throughout the gear train is determined by the position of the idler gear axle, which is located to the backplate by two dowels. If the axle or backplate, or both, have been renewed the axle location must be re-established, the dowel holes of new components having a reaming allowance for the purpose.

The work is carried out in the following manner, after the camshaft and drivegears have been fitted as described in Sect. 3, Items 7 and 8.

1. With the engine in running position, fit the backplate stiffening frame GA.668 (fig. 3).
2. Fit the idler gear axle, without dowels, and nip its setbolts. Slide the idler gear into position and, at four equidistant points on its circumference, measure the backlash between idler gear and crankshaft pinion, camshaft drivegear and auxiliary drivegear (see Section 3, fig. 8). Tap the idler gear hub to move the axle as necessary until each backlash is between 0.004 and 0.010 inch (0.10 and 0.25 mm.) and as equal as possible to the others.
3. Taking care not to disturb the axle, remove the idler gear and tighten the axle setbolts. Ream the dowel holes as follows, using jig GA.338 and reaming kit GA.470 (fig. 3).
4. Fit reaming jig GA.338 to the axle, with $\frac{1}{32}$ inch locating pin GA.339 in one dowel hole. Using $\frac{5}{16}$ inch reamer GA.258, ream the other hole.
5. Fit locating pin GA.340 in the reamed hole, remove pin GA.339, and ream its hole to $\frac{5}{16}$ inch. If both axle and backplate are new, remove the axle, clean out all swarf and continue assembling as described in Section 3 from 'Wheelcase backplate' (Item 6) onwards, using $\frac{5}{16}$ inch dowels OE.5111 and new circlips OE.2296.
6. If either axle or backplate are not new, ream the dowel holes oversize as necessary, in similar manner. Reamers and locating pins are supplied in two increments of $\frac{1}{64}$ inch; see list at end of this Section. When oversize dowels OE.36495 ($\frac{21}{64}$ inch) or OE.39790 ($\frac{11}{16}$ inch) are to be fitted, open out their circlip counterbores in the idler gear axle, using recessing tool GA.106. The same circlip, OE.2296, is used on all three sizes of dowel.

ASSEMBLING

Instructions are given in Sect. 3 under 'Wheelcase cover' and 'Crankshaft front end'. (Items 21 and 23).

SPECIAL TOOLS

- OE.44022 Spanner, crankshaft hub nut
- OE.44409 Extractor, auxiliary drivegear
- GA.668 Stiffening frame, wheelcase backplate
- GA.338 Jig, idler axle dowel reaming
- GA.470 Kit, reaming idler axle dowels, comprising:
 - GA.258 Reamer, $\frac{5}{16}$ inch (standard)
 - GA.104 Reamer, $\frac{21}{64}$ inch (1st oversize)
 - GA.105 Reamer, $\frac{11}{16}$ inch (2nd oversize)
 - GA.106 Recessing tool, dowel circlip counter-bore
- GA.339 Locating pin, $\frac{1}{32}$ inch
- GA.340 Locating pin, $\frac{5}{16}$ inch
- GA.341 Locating pin, $\frac{21}{64}$ inch
- GA.342 Locating pin, $\frac{11}{16}$ inch
- GA.420 Kit, renewing crankshaft front seal on assembled wheelcase, comprising:
 - GA.364 Extractor
 - GA.694 Inserting tool
 - GA.421 Box

Printed in Great Britain

FITS AND CLEARANCES

WHEELCASE GEARS

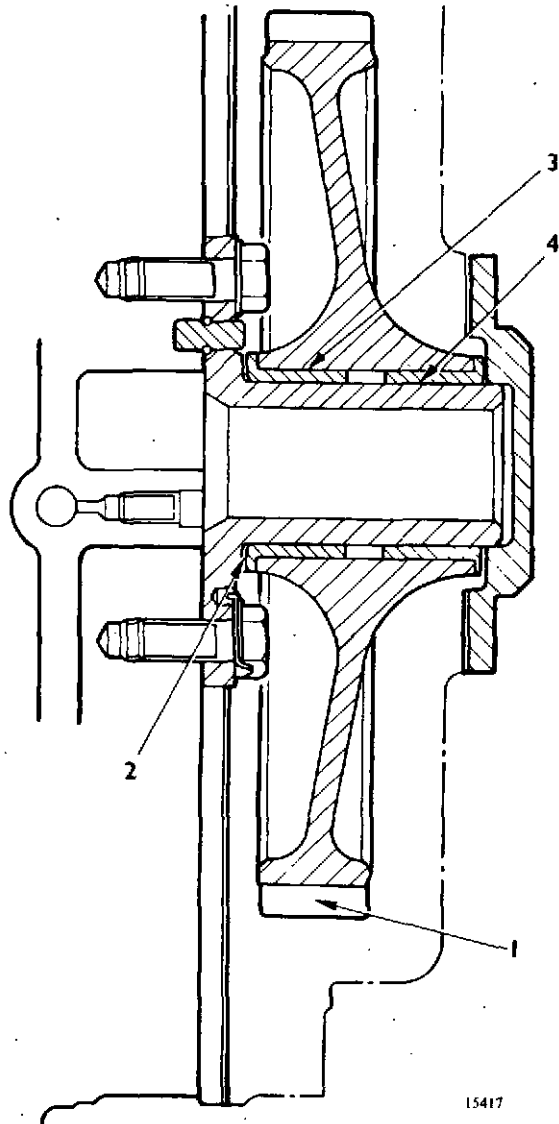

15417

No. ON DIAG.	DESCRIPTION	DIMENSIONS NEW		PERMISSIBLE WORN DIMENSIONS		CLEARANCE NEW		PERMISSIBLE WORN CLEARANCE		REMARKS
		in.	mm.	in.	mm.	in.	mm.	in.	mm.	
1	IDLER GEAR BACKLASH Backlash between idler gear and: Crankshaft pinion } Auxiliary drivegear } Camshaft drivegear }					0-004 to 0-010	0-10 to 0-25	0-012	0-30	Measured, in each instance, with idler gear in four equally-spaced positions
2	IDLER GEAR AND AXLE Idler gear end float					0-013 to 0-027	0-33 to 0-68	0-045	1-14	
3	Bushes in idler gear Gear - bore	1-8125 to 1-813	46-04 to 46-05				Interference			
	Bushes - diameter	1-8155 to 1-816	46-11 to 46-13				0-0035 to 0-0035			
4	Idler gear on axle Bushes - bore	1-625 to 1-6255	41-27 to 41-29					0-004	0-10	
	Axle - diameter	1-6235 to 1-624	41-24 to 41-25							

ROLLS-ROYCE DIESELS



SECTION 13—TURBOCHARGER, HOLSET

MODEL 4LGK

Printed in Great Britain

The turbocharger is a turbine-driven compressor which utilises the waste energy of the exhaust gases to increase the mass airflow to the cylinders. Turbine and compressor are carried at opposite ends of a shaft which rotates in fully-floating bearings lubricated by pressure oil from the filter header. The oil returns to the sump via a large-bore pipe.

Full information concerning operating precautions, routine maintenance, bearing checks and compressor cleaning, is given in the Engine Servicing Manual T.S.D. 3126.

Operators are strongly advised to make use of the Rolls-Royce Service Exchange Scheme when a turbocharger is due for overhaul.

REMOVAL

1. Disconnect the air intake piping to the turbocharger at the compressor inlet and the air cleaners. *Remove the piping.*
2. Break the hose connections of the air delivery pipes at the manifold duct and at the turbocharger. *Remove the pipe and blank off the duct opening.*
3. If applicable take the weight of the diffuser whilst disconnecting it.
4. Disconnect the oil feed pipe at the turbocharger bearing housing and at the header bracket of the engine oil filters; remove the pipe.
5. Release and remove the oil drain pipe.
6. Remove the nuts securing the turbocharger to the exhaust manifold and lift the turbocharger from the engine.

Information necessary for complete overhaul is given in the Manufacturer's publication issued by the Holset Engineering Company Limited, Turnbridge, Huddersfield, for each model.

REFITTING

Refitting the turbocharger is the reverse of dismantling but it is advised that the following points be noted:

1. When fitting the turbocharger to the engine, check that the induction and exhaust systems are free from dirt and loose articles.
2. Ensure that all joints are properly made, using new hoses of correct material, and check that the oil supply and drain pipes are clear and undamaged.
3. Make certain that the compressor inlet and outlet piping is not producing strain on the compressor cover.
4. Before starting the engine, prime the turbocharger bearings by pouring one-third pint (0.2 litre) of engine oil into the filler pipe on the bearing housing.

PRECAUTIONS AFTER OVERHAUL

Before a new or overhauled engine equipped with a Holset 4LGK turbocharger is run at Rolls-Royce an expendable filter OE.43712 is fitted to the turbocharger oil inlet flange; this protects the turbocharger bearings during initial running and is then removed and destroyed. Dealers and Operators wishing to adopt this precaution are reminded that (1) the filter *must* be removed before the engine goes into service and (2) the filter cannot be cleaned and *must* be destroyed on removal to prevent re-use.



**SECTION 14—ELECTRICAL EQUIPMENT
PART 1—STARTER MOTOR
C.A.V. S130L**

DESCRIPTION

The S130L starter is a 24-volt unit of co-axial construction incorporating a two-stage solenoid switch unit mounted internally around the armature shaft. It is splash and dust proof and oil sealed at the drive end.

Pinion engagement occurs at reduced power thereby avoiding heavy engagement shock and excessive wear of the pinion and flywheel ring gear. Full power is applied when the pinion is fully engaged and locked in position to prevent premature ejection.

OPERATION

The battery supply is connected to the main terminals and when the solenoid is energised the pinion assembly moves forward to its first position. The armature rotates under reduced power and when the pinion has almost reached the fully engaged position the second stage contacts close and full battery power is applied. When the pinion sleeve is in the fully forward position it becomes locked.

The pinion speed is rapidly increased by the engine flywheel when the engine starts. A ratchet device now operates and allows the pinion to rotate at a faster rate than the armature until both are at the same speed, when the ratchet ceases to operate. Should the engine start to drive the armature at a speed in excess of the permitted maximum an overspeed device will operate to return the pinion to its retracted position.

DISMANTLING

Commutator end shield (fig. 1 and fig. 2)

Secure the starter horizontally by the yoke in a soft jawed vice with the large terminal at the commutator end in the 12 o'clock position.

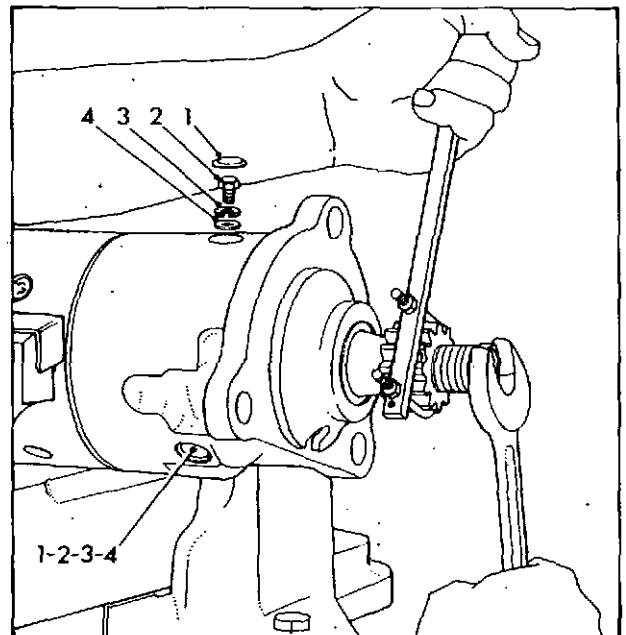

Fig. 1 Loosening pinion stop nut

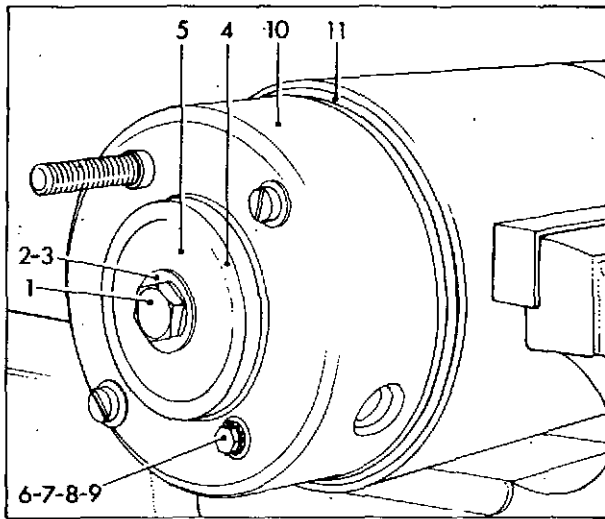

Fig. 2 Removing commutator end shield

Hold the pinion using a suitable tool and unscrew the stop nut two or three turns only. This nut has a left-hand thread. Remove the two core plugs (1) from the drive end shield using a sharp pointed instrument. Unscrew the field terminal screws (2) and remove them together with the spring (3) and plain (4) washers.

Unscrew the commutator end terminal nut and remove the washers, seal and insulating bush.

Remove the commutator end shield cover, through bolts and lift off the cover.

Hold the pinion as previously described and remove the commutator end bolt (1) fig. 2 together with thrust washer (2) and shims (3). Note the number of shims fitted to the drive end shield and retain them for use when re-assembling.

Remove oiler sealing ring (4) and felt washer (5).

Remove screw (6) together with washer (7) washer (8) and bush (9). Remove commutator end shield (10) and retain shims for use when assembling.

Brushgear (fig. 3)

Lift each brush spring (1) fig. 3 in turn and remove the brush (2) from holder. Remove the screws (3) and

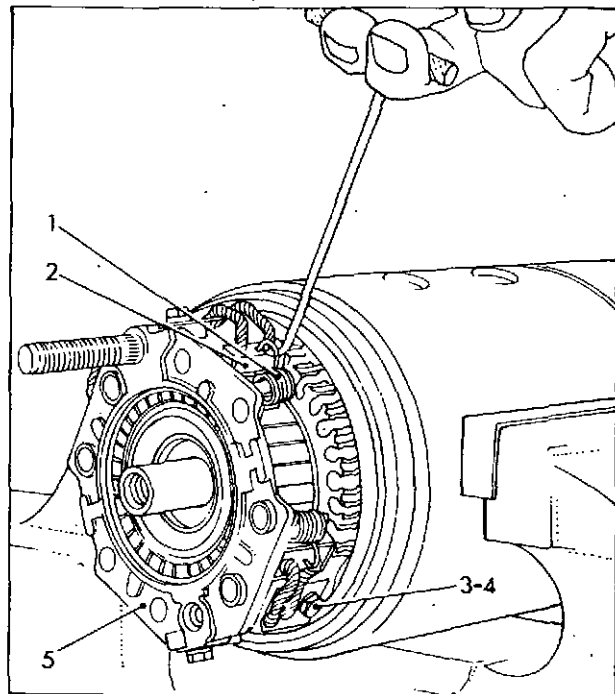

Fig. 3 Removing brushgear

spring washers (4) connecting leads and field coil connectors to brush boxes. Complete brushgear assembly can now be removed.

Drive end shield and pinion sleeve (fig. 4 and fig. 5)

Tap the drive end shield (1) fig. 4 away from the yoke, using a soft hammer, and withdraw it complete with armature. Support the unit as shown to avoid damaging the windings and commutator.

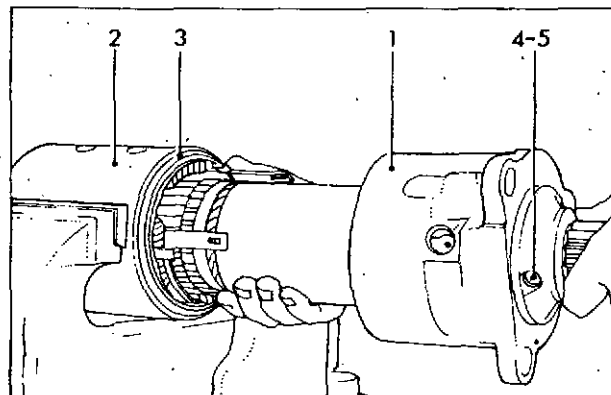

Fig. 4 Removing drive end shield

Remove and discard sealing ring (3).

Using a suitable tool remove oiler core plug (4) and spring.

Discard the plug.

Remove the yoke from vice.

Clamp the armature horizontally in a soft jawed vice and remove pinion stop nut, thrust washer and return spring. Release the ball lock mechanism by pushing the end shield towards the armature and unscrewing the pinion sleeve along the helix until it disengages.

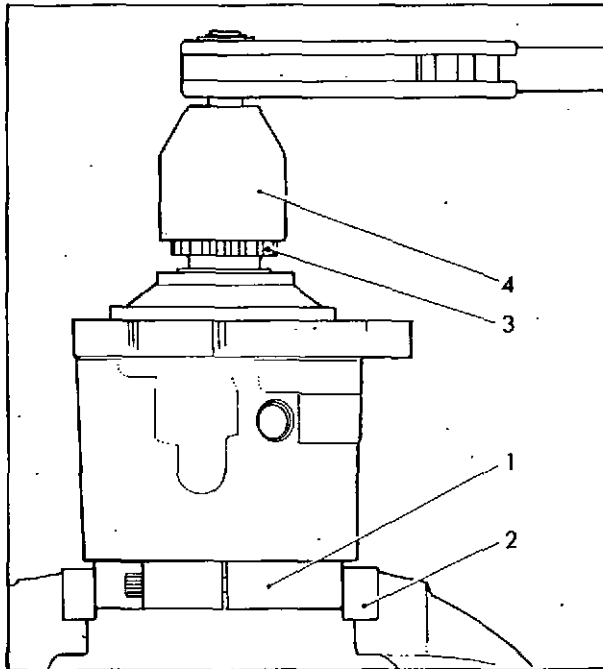

Fig. 5 Removing pinion sleeve

Slide the pinion sleeve together with the drive end shield off the armature shaft. Retain the eight 0.197 ins (5mm) steel balls. Place C.A.V. Tool No. 6244-50 over the trip plate boss and tighten the clamp screw to secure in position. Invert the complete assembly and clamp the tool (1) fig. 5 in the vice (2).

Unscrew the pinion (3) two or three turns using the correct size C.A.V. pinion socket tool.

Release the assembly from the vice and remove tool 6244-50. Unscrew and remove the trip plate together with the lock collar spring and lock collar.

Remove the pinion sleeve from the drive end shield.

Solenoid switch unit (fig. 6 and fig. 7)

Remove screw (1), spring washer (2) and plain washer (3) connecting flexible lead from the resistor to moving contact of switch.

Unscrew nuts (4) from solenoid terminals and remove spring washers (5), plain washers (6), insulating bushes (7) and rubber sealing rings (8). Withdraw solenoid terminals inwards until they are clear of the resistor plate (10).

Remove the resistor (11) and leatheroid insulator (12) from the drive end shield.

Remove main terminal screw (13), spring washer (14), plain washer (15) and two 'Posidrive' screws (16) with spring washers (17).

Withdraw switch assembly (18) from drive end shield and lift out the plunger return spring.

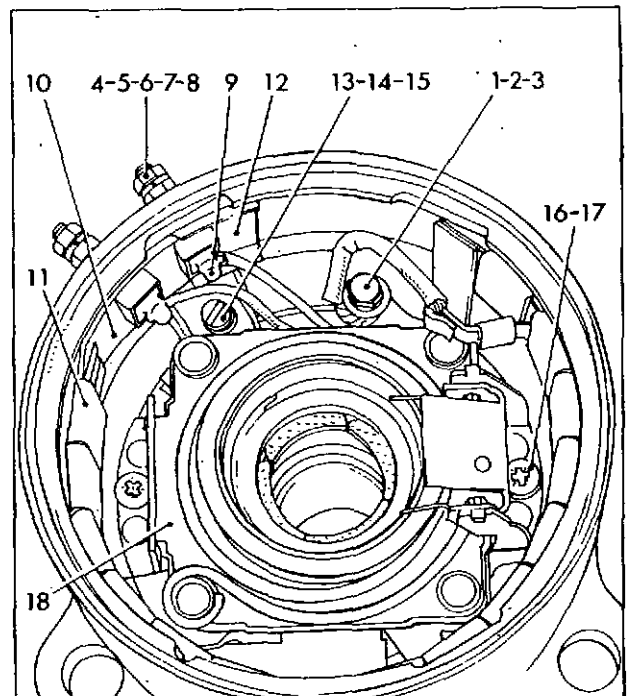

Fig. 6 Removing solenoid switch unit

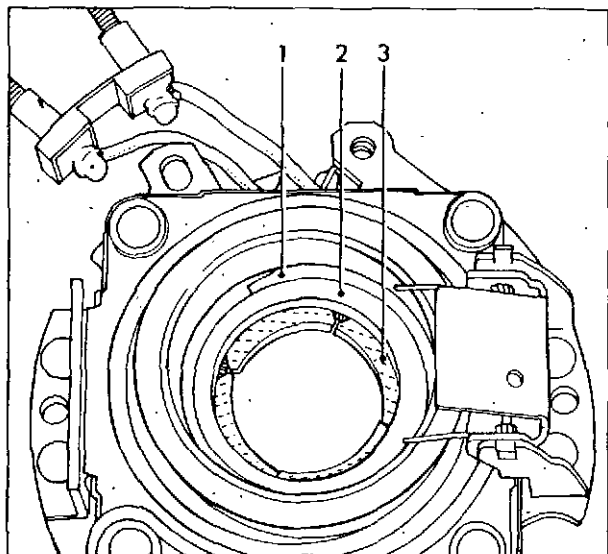

Fig. 7 Removing solenoid plunger segments

Remove 'Spiroflex' circlip (1) fig. 7 by levering the end inwards and 'winding' it out of its groove.

Remove retaining washer (2) and lift out the four segments (3) together with the garter spring:

To remove the main terminal from the drive end shield unscrew and remove the two nuts, spring washers, plain washers, seal locator, insulating washer and sealing washer.

Lift out the terminal assembly from inside the end shield.

Armature (fig. 8 and fig. 9)

Lightly clamp the shaft vertically in a soft jawed vice with the commutator uppermost as shown in fig. 8.

Remove recoil housing (1) from inside commutator sleeve (2). Two holes (3) in the wall of the housing permit the use of two hooked instruments if it is tight in the sleeve.

Slide the two annular keys (4) outwards from the groove in the shaft.

The armature can now be removed from the shaft, using a twisting movement.

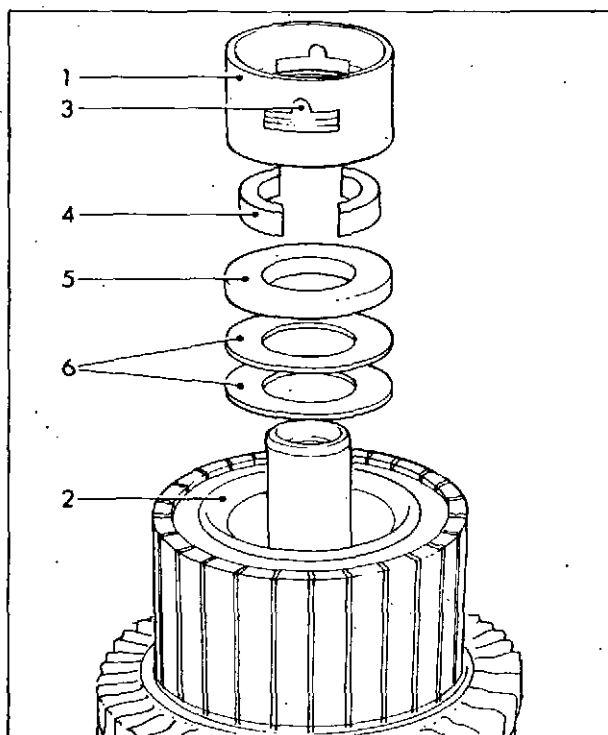

Fig. 8 Removing armature shaft

Remove the two annular keys, thrust washer (5) and shims (6) from the commutator sleeve together with the thrust washer from the shaft. Retain shims

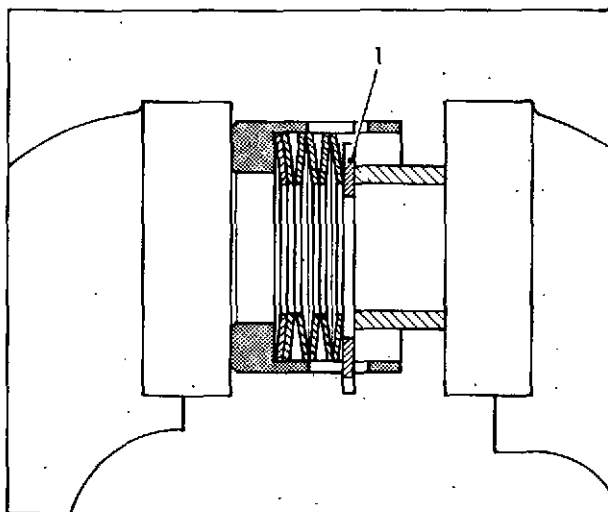

Fig. 9 Dismantling recoil unit

and thrust washers for use on assembly, and remove the shaft from the vice. To dismantle the recoil unit, compress the 'Belleville' washers slightly in a vice using a suitable piece of tubing or rod as shown in fig. 9.

Tap the lock plate (1) sideways until the tongue on one side is clear of the groove in the wall. Release the pressure and lift out the lock plate and 'Belleville' washers.

INSPECTION AND REPAIR

Armature

Examine the windings visually for damage and ensure the bindings are secure and in good condition.

Remove all dust with dry compressed air before testing the windings for continuity, shorted turns, and insulation, with a 'Growler' armature testing machine.

Measure the internal diameter of both bushes. The maximum permissible bore size is 0.790 in (20.075 mm) for the drive end bush and 0.635 in (16.118 mm) for the commutator end bush. If the internal diameter of either bush is greater than these limits, it must be renewed.

Remove the ratchet assembly from inside the armature and examine for wear; renew parts as necessary.

C.A.V. Tool Nos. 6244-31, 6244-32, 6244-33, 6244-36 and 6244-37 are necessary for the removal and refitting of bushes.

The commutator end bush can now be removed using a suitable extractor. Alternatively, it can be removed by driving it out from the commutator end with a sharp pointed implement.

Note: On later machines the hole in the commutator sleeve is increased in diameter to allow the bush to be removed with tool No. 6244-33.

Place the guide tool No. 6244-36 on the fitting pin tool No. 6244-37 and position the new commutator

end bush on the end spigot of the pin. Place the assembly into the armature so that the commutator end bush is just entered into its housing and the guide is in position against the shoulders of the splines. Apply pressure to the end of the pin to press the commutator end bush fully home.

Lightly smear the ratchet components with Aero Shell 16 grease, then assemble them into the armature in the following order: thrust washer (1) fig. 10, armature sleeve ratchet (2), thrust ring (3), helix sleeve ratchet (4), spring (5) and washer (6).

Position the new drive end bush on fitting pin tool No. 6244-31 and insert the pin into the armature so that the end spigot enters the commutator end bush. Apply pressure to the end of the pin until the drive end bush is fully home. The pressure required will be between 3 to 6 tonf (3,000 and 6,000 kgf).

Examine carefully the complete armature shaft for signs of wear or damage, with particular attention to the ratchet and pinion helices and the shoulder of the annular groove for the steel locking balls.

The commutator can be cleaned with a very fine grade of glass paper. Emery or carborundum paper must NOT be used. If the commutator surface is pitted or grooved it may be set up in a lathe and skimmed to a very fine finish.

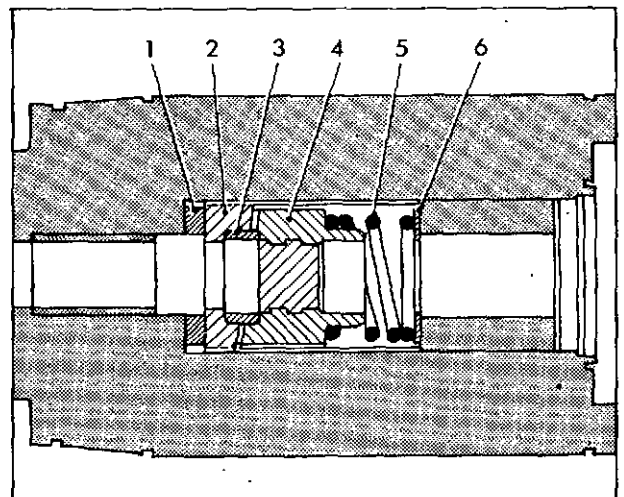

Fig. 10 Assembling ratchet mechanism

Printed in Great Britain

Note: The commutator must be concentric with the armature bearings to within ± 0.002 in (0.05 mm) and may be machined to a minimum diameter of 2.319 in (58.90 mm).

The full width of the commutator segment insulators should be undercut to a minimum depth of 0.040 in (1 mm).

Brushgear

Remove all dust with dry compressed air and inspect visually for signs of wear or damage.

Test the insulation between positive and negative brush boxes using a suitable test instrument; a reading of 1 Megohm should be obtained.

Brushes should be renewed if damaged or less than 0.39 in (10 mm) in length.

New brushes should be bedded in until 80% of the contact area conforms to commutator curvature.

Drive end shield and pinion sleeve

Lever out and discard the bearing bush oil seal.

Visually inspect the drive end shield casting for cracks or damage to the sealing ring recess, mounting flange or threads.

Check the bearing for wear and if the internal diameter exceeds 1.264 in (32.10 mm) the bearing must be renewed as follows:

Remove the oiler sealing plug and spring and extract the old bearing with tool No. 6244-41. Discard the felt wick. Position a new felt wick in line with the oiler hole and insert the felt retaining collar tool No. 6244-42 into the bore of the drive end shield to retain the wick while the new bush is being fitted.

Blank out the rectangular cut-out in the new bush to prevent swarf getting on the felt wick and press the bush into position in the drive-end shield.

After fitting the bush must be fine bored to the correct internal diameter of $1.260 + 0.001$ in ($32 + 0.03$ mm).

Remove the blanking from the hole in the bush and press in a new oil seal with the lips facing outwards as shown in fig. 11.

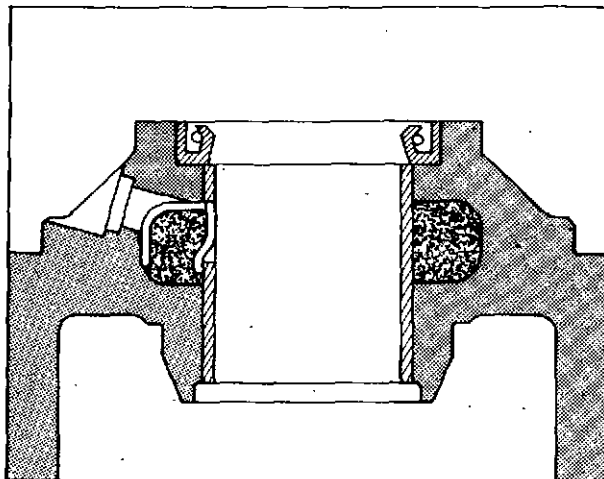

Fig. 11 Drive end oil seal

Note: If a new end shield assembly is being fitted, the leatheroid pad must be removed from the bearing bush before the starter is assembled.

Examine the bearing surfaces of the pinion sleeve for signs of excessive wear or damage. The oil seal in the bore of the sleeve should be renewed when a complete overhaul is being undertaken.

Extract the old seal from the threaded end of the sleeve using a hooked implement. The new seal should be inserted into the bore from the same end and eased into its groove using a round ended tool that will not damage the seal lip.

When correctly installed, the seal lip must be facing towards the pinion teeth as shown in fig. 12.

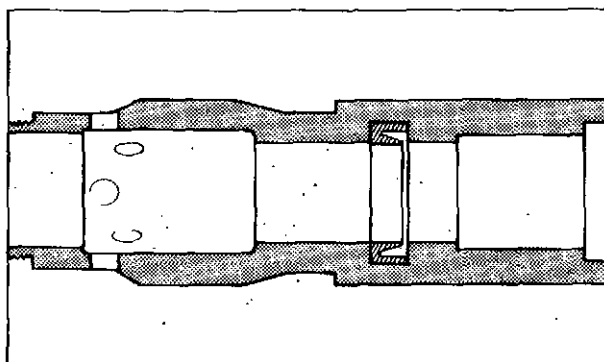

Fig. 12 Pinion sleeve oil seal

If the pinion teeth show signs of damage or excessive wear, the complete pinion sleeve must be renewed. The new pinion sleeve complete with oil seal is available as an assembly.

Solenoid switch unit

Inspect the complete unit for damage and excessive wear with particular attention to the insulation of coil and leads. Ensure insulating bushes are undamaged and the rivets are tight. Check coil continuity using a suitable test instrument or, alternatively, a low voltage battery and lamp wired in series. Test the coil insulation with a 100 volt 'Megger' or similar insulation tester. A reading of 1 megohm should be obtained between coil leads and plunger sleeve.

Should the coil prove faulty the complete solenoid and switch assembly must be renewed.

To check that the switch is operating correctly, stand the plunger return spring on the bench and place the solenoid switch unit over it, coil downwards, as shown in fig. 13. Apply downward pressure to the top of the plunger (1) and check that the first stage contacts (2) close.

Maintain the pressure and depress the trigger (3); the second stage contacts (4) should now snap together. Hold the coil (5) firmly against the bench and release the downward pressure on the plunger.

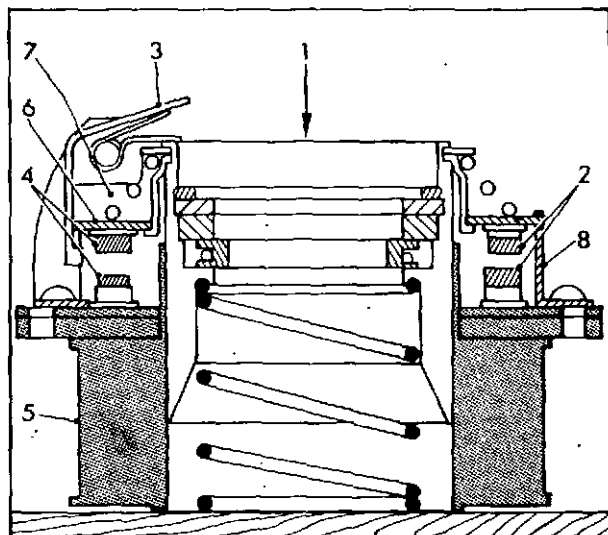

Fig. 13 Checking switch unit operation

The moving contact plate (6) should be moved upwards by the plunger return spring so that it locates behind the step on the trigger.

Check the condition of both sets of contacts and if necessary clean surfaces with very fine carborundum paper and wipe over with white spirit.

Note: If contacts are excessively burnt or pitted they must be renewed as follows:

Spring the two arms of the trigger guide (7) apart and remove the trigger complete with spring and spindle.

Remove the four rivets retaining the contact stop (8) and remove the contact stop and trigger guide. The moving contact and plunger assembly can now be removed followed by the 'fixed contact' plate.

Remove the four rivets (1) fig. 14 holding the 'moving contact' assembly together and this allows the contact (2) and insulator (3) to be removed from the latch plate (4).

When fitting the new moving contact, first assemble the 'insulator' and 'moving contact' to the latch plate ensuring that the 'second stage contact' (5) is adjacent to one of the two lips (6) on the latch plate as shown.

Re-assemble with new rivets as illustrated in fig. 14, ensuring that the long insulating bush (7) is passed through the spring eye and is in the shown position.

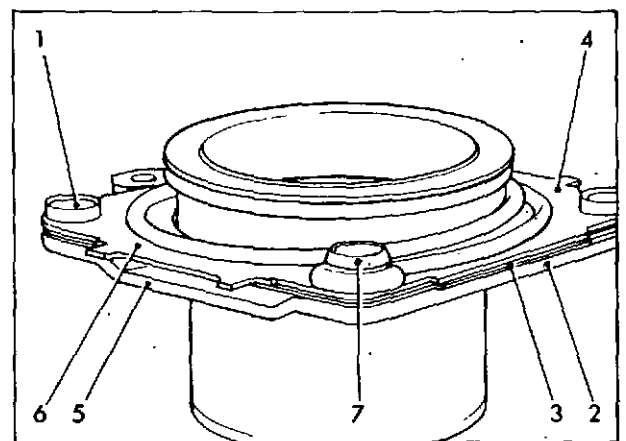

Fig. 14 Renewing switch moving contract

Printed in Great Britain

During the assembly of the complete switch unit, place the 'fixed contact plate' onto the coil ensuring the angled slot locates over the raised moulded part of the coil bobbin cheek. Smear the outside diameter of the plunger and the bore of the coil tube with Aero Shell 16 grease.

Place the plunger into the tube ensuring that the 'moving contacts' align correctly with their fixed counterparts. Insert two rivets through the trigger guide, moving contact plate and fixed contact plate; rest the rivet heads on a suitable support and punch over end of rivet.

Secure the contact stop in position with two rivets.

Position the trigger assembly so that the spring ends rest on top of the plunger and then spring it into position between the guide arms. Ensure that the ends of the spindle enter correctly into the two holes.

Check the operation of the complete unit as previously described. Examine the four segments for wear or damage and, if necessary, renew as a complete assembly.

Field coils (fig. 15)

Remove all traces of brush dust with dry compressed air. Inspect the coil insulation and insulating strip for signs of damage. Test the insulation with a 100 volt 'Megger' or similar test instrument. A reading of 1 Megohm should be obtained between each field coil connection and the yoke. If it is necessary to remove the field coil assembly, proceed as follows with reference to fig. 15.

Note the position of both long field coil connectors (1) in relation to the dowel pin (2) at the drive end of the yoke. Unscrew and remove the eight screws (3) securing the pole shoes (4) to the yoke. The field coils (5) and pole shoes can now be removed together with both leatheroid strips (6). When replacing the field coils into the yoke ensure that the long connectors are in the correct position relative to the dowel pin.

Place each pole shoe in its correct position with the stamped number on the end towards the drive end of the yoke. When viewed from the drive end the first pole shoe past the dowel should be number 3 followed by numbers 4, 1 and 2.

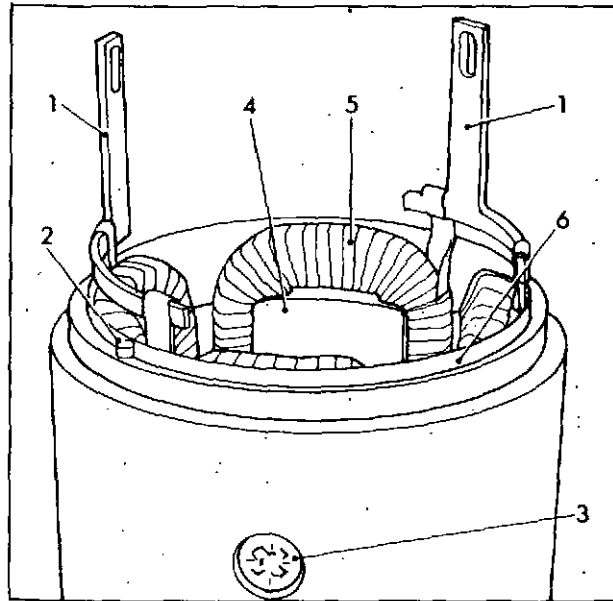

Fig. 15 Dismantling field coils

Secure each pole shoe with two screws, finger tight only. Place two leatheroid strips under the field coils ensuring they are correctly positioned and then tighten all eight pole shoe screws fully.

Commutator end shield (fig. 16)

Ensure the bearing is tight in the housing. If the bore of the bearing (1) exceeds 0.633 in (16.087 mm) the bearing must be renewed.

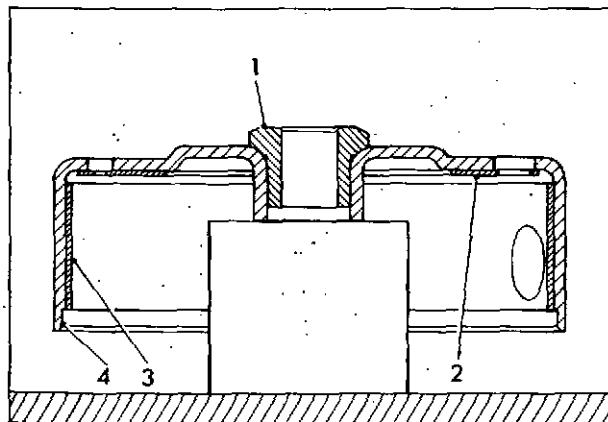

Fig. 16 Commutator end shield bearing

Inspect the insulating plate (2) and strip (3) for damage and renew if necessary, securing into position with 'Bostik' clear adhesive No. 1437. Ensure that the holes in the strip and plate align with the holes in the end shield and that the insulating strip does not protrude into the spigot recess (4).

ASSEMBLY

It is recommended that all sealing devices and locking washers are renewed during assembly.

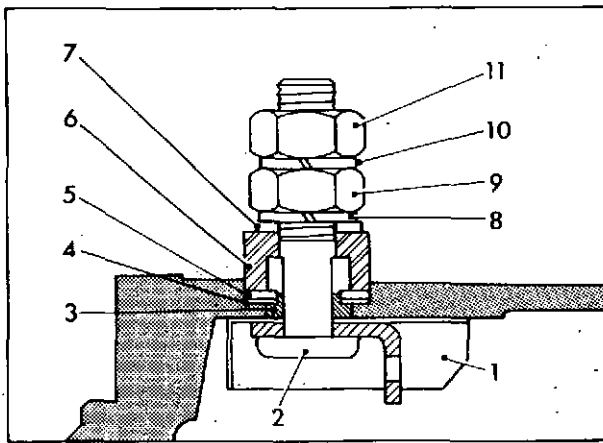

Fig. 17 Drive end terminal assembly

Solenoid switch unit (fig. 17)

Place the moulded insulator (1) over the terminal (2) as shown and place sealing washer (3) in position. Pass the terminal through the hole in the drive end shield which has the large counterbore on the outside. Assemble the items 4-7 inclusive in position and secure with spring washer (8) and nut (9); tighten nut to a torque loading of 9 to 10 lbf.ft (12.2 to 13.6 Nm). Place spring washer (10) in position and screw on nut (11) finger tight.

Ensure that the segments and inside of the plunger are clean and free from oil or grease.

Assemble the four segments (2) fig. 18 inside the spring (1) and position them in the solenoid plunger. Fit the retaining washer (3) over the segments ensuring that the projections on the underside engage between the segments and that the slot locates over the tongue

in the wall of the plunger recess. Insert the 'Spirolox' circlip (4) into the groove in the plunger bore and lightly smear the trigger spring (5) and spindle (6) with Aero Shell 16 grease.

Smear the solenoid plunger return spring with Aero Shell 16 grease and place it in the drive end shield. Insert switch assembly into the shield with the 'fixed contact' connecting arm in line with the main terminal. Fit retaining screws (1) fig. 19 with spring washers (2) and tighten screw to a torque value of 18 to 20 lbf.in (2.03 to 2.26 Nm). Insert screw (3) together with washers (4) and (5) and tighten to torque value of 18 to 20 lbf.in (2.03 to 2.26 Nm). Fit leatheroid insulator (6) in resistor groove and assemble resistor (7) into position in the drive end shield.

Fit the insulator (8) over the terminals (9) and insert terminals through the resistor plate (10), leatheroid insulator and drive end shield. Fit sealing ring (11), insulating bush (12), plain washer (13), spring washers (14) and nuts (15) to each terminal. Tighten to torque value of 18 to 20 lbf.in (2.03 to 2.26 Nm).

Secure resistor flexible lead to switch with screw (16), spring washer (17) and plain washer (18) and tighten to torque value of 15 to 18 lbf.in (1.69 to 2.03 Nm).

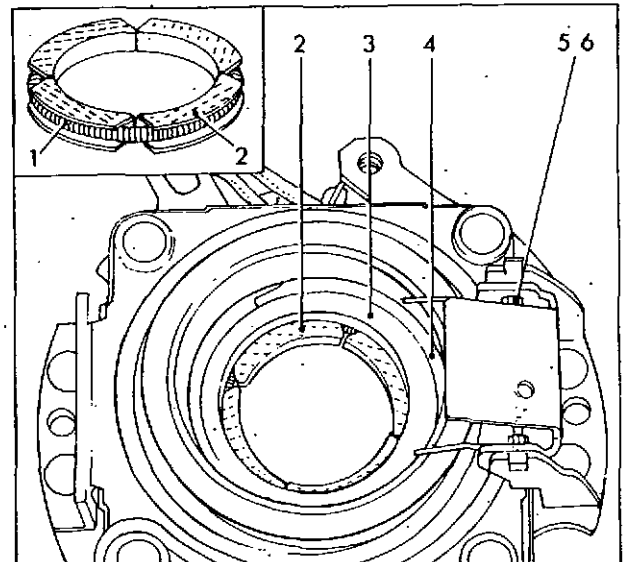

Fig. 18 Assembling solenoid plunger segments

Printed in Great Britain

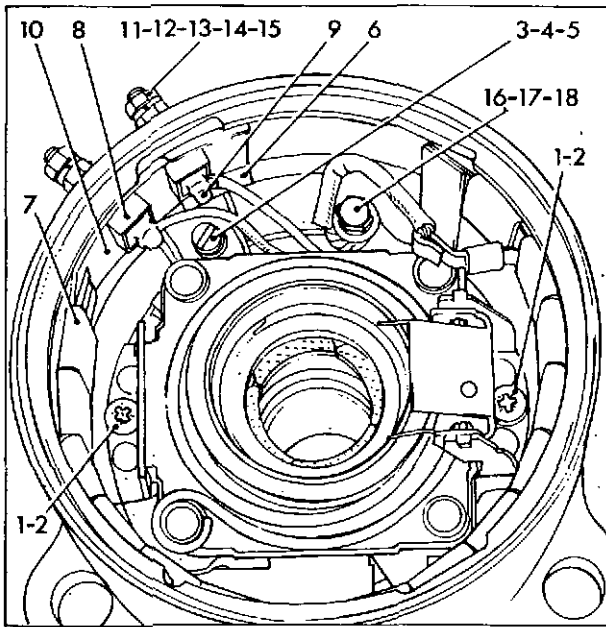

Fig. 19 Replacing solenoid switch unit

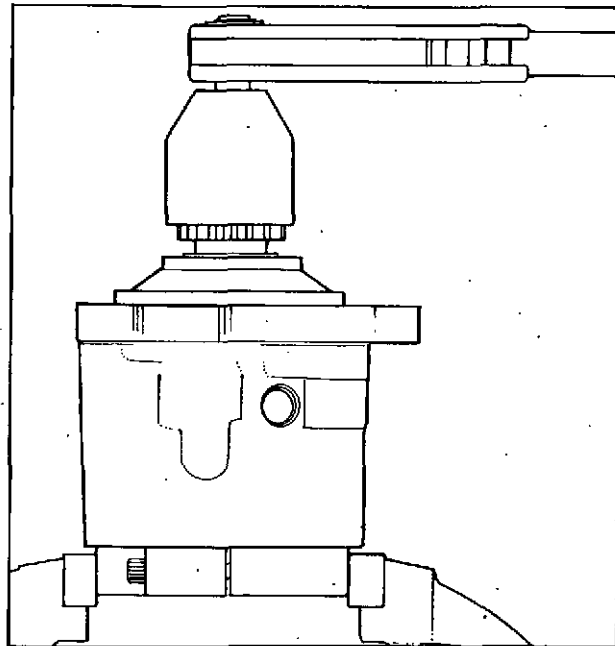

Fig. 21 Tightening trip plate

Pinion sleeve

Check that the leatheroid pad has been removed from the drive end shield bush.

Fit split collar tool No. 6244-43 into the drive end seal and lubricate bearing bore and pinion sleeve with Tellus T27 oil before inserting pinion sleeve into the end shield bearing. Remove the split collar when the sleeve is nearly home and guide sleeve carefully through the four segments.

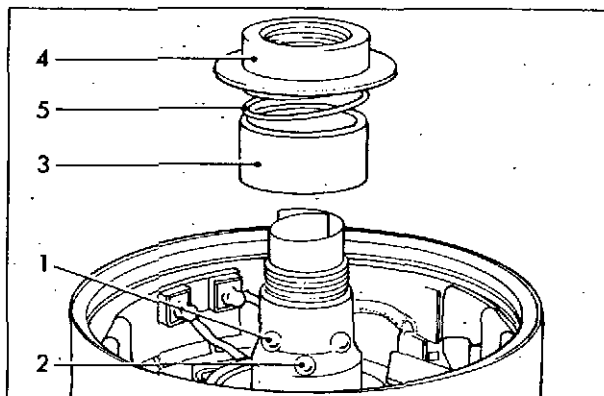

Fig. 20 Assembling pinion sleeve

Grip the pinion teeth firmly in a soft jawed vice so that the threaded end is uppermost as shown in fig. 20.

Form a piece of stiff paper into a tube and insert it into the pinion sleeve bore to prevent the balls from falling inside.

Smear the locking balls (1) and overspeed balls (2) with Aero Shell 16 grease and insert them in the positions shown. Place locking collar (3) in position over the balls.

Degrease the threads of the pinion sleeve and trip plate (4) and then smear both threads with 'Loctite' green retaining compound No. 290.

Place spring (5) in position and screw on the trip plate finger tight.

Secure tool No. 6244-50 over the trip plate boss and clamp the assembly in vice as shown in fig. 21. Using the correct pinion socket, tighten the pinion to a torque value of 40 to 50 lbf.ft (54.2 to 67.8 Nm).

Armature shaft

Lightly smear the 'Belleville' washers (1) fig. 22 with Aero Shell 16 grease and assemble them into the recoil housing (2) as illustrated.

Insert one side of lock washer (3) in the slot in recoil housing and compress the 'Belleville' washers, as shown in fig. 22, until the lock washer can be engaged in the other slot. Clamp the armature shaft vertically in the vice with the threaded end downwards.

Smear the short shaft helix and thrust washer with Aero Shell 16 grease and place the washer on the shaft. Fit the armature to the shaft with a twisting movement to enable the shaft helix to engage with the helix in the ratchet sleeve.

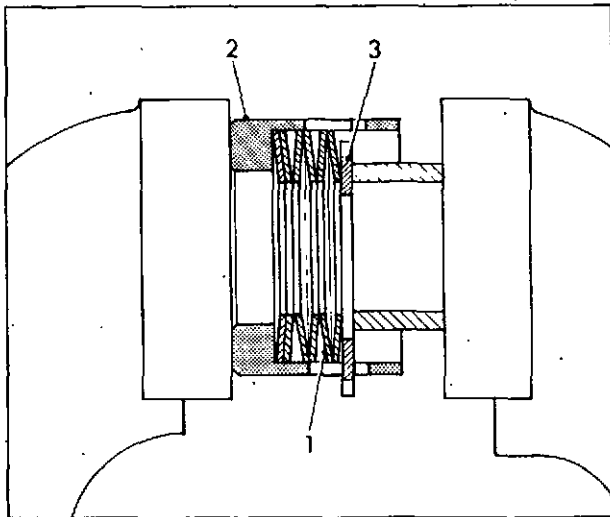

Fig. 22 Assembling recoil unit

Smear the original shims (1) fig. 23 and thrust washer (2) and insert in correct order into commutator sleeve (3). Ensure that the shaft is fully home by applying slight downward pressure and fit keys (4) into the annular groove of the shaft.

Check shaft end float while sufficient pressure is applied to the shaft to overcome the reaction of the ratchet spring. The end float should be between 0.002 and 0.014 in (0.05 and 0.35 mm) and may be adjusted by the addition or subtraction of shims. Use the least number of shims possible and ensure that the thickest shim is next to the keys.

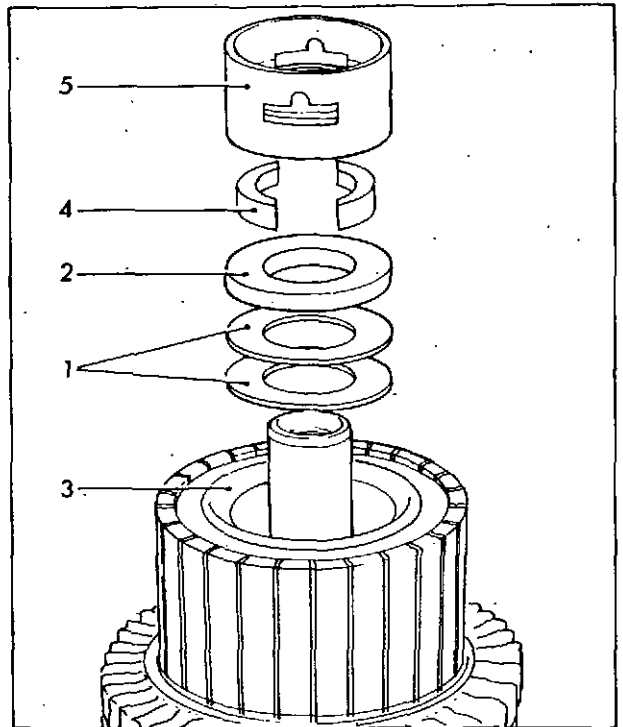

Fig. 23 Replacing armature shaft

Fit the assembled recoil unit (5) into the armature sleeve ensuring that the bore in the lower part locates over the two keys.

Check operating of the ratchet mechanism by turning the armature which should only rotate in one direction.

Remove the armature assembly from the vice.

Drive end shield

Lightly smear helix and bearing surfaces of the armature shaft with Aero Shell 16 grease and clamp the unit horizontally in a soft jawed vice.

Pull the pinion (1) fig. 24 fully out of the drive end shield and retain it in this position.

Slide the pinion and drive end shield onto the armature shaft and release the pull on the pinion.

Remove the paper tube from the pinion before the end shield is fully in position.

Printed in Great Britain

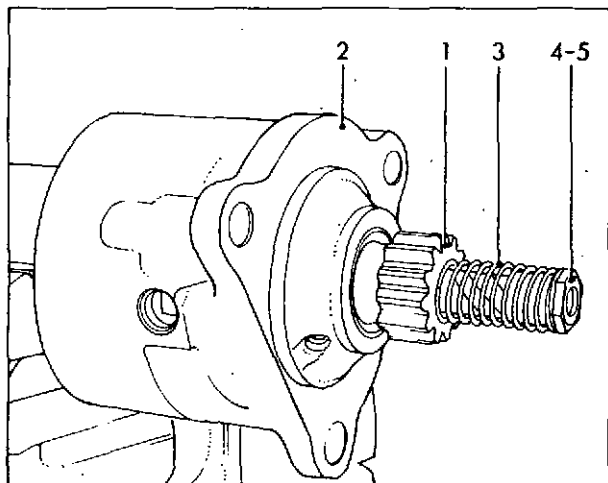

Fig. 24 Assembling drive end shield

Fit the pinion return spring (3) thrust washer (4) and secure with pinion stop nut (5), finger tight only; remove armature from the vice.

Oil the bearing wick with Tellus T27 oil and fit oiler spring and new core plug.

Armature and brushgear

Secure yoke in vice as shown in fig. 25 and place a new sealing ring (1) in position. Insert the armature (3) while taking care to avoid damage to the windings or commutator. Ensure that the dowel in the end of yoke engages with the hole in the drive end shield (4). If necessary tap the shield into position with a soft faced mallet.

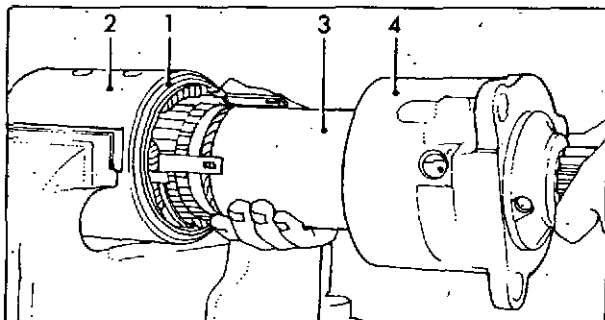

Fig. 25 Replacing armature into yoke

Assemble the brushgear assembly onto the commutator end of the yoke with the large terminal post (1) fig. 26 in line with the register pip on the yoke end.

Fit screw (2) with spring washer (3) through each positive brush lead tag (4) and screw through brushgear into the brushgear assembly. Do not fully tighten the screw.

Insert brushes into holders and secure the remaining two unattached leads with screws (5) and spring washers (6), tightening to a torque value of 15 to 18 lbf.in (1.69 to 2.03 Nm).

Smear the original shims (7) with Aero Shell 16 grease and replace them in the recoil housing, thickest shim last.

Renew sealing ring (8).

Check brush spring tensions with a gauge as shown. Indicated pressure when the spring starts to leave the brush should read 5.25 to 5.50 lbf (2.38 to 2.49 kgf).

Commutator end shield

Ensure that both the insulating plate and strip are in position inside the commutator end shield.

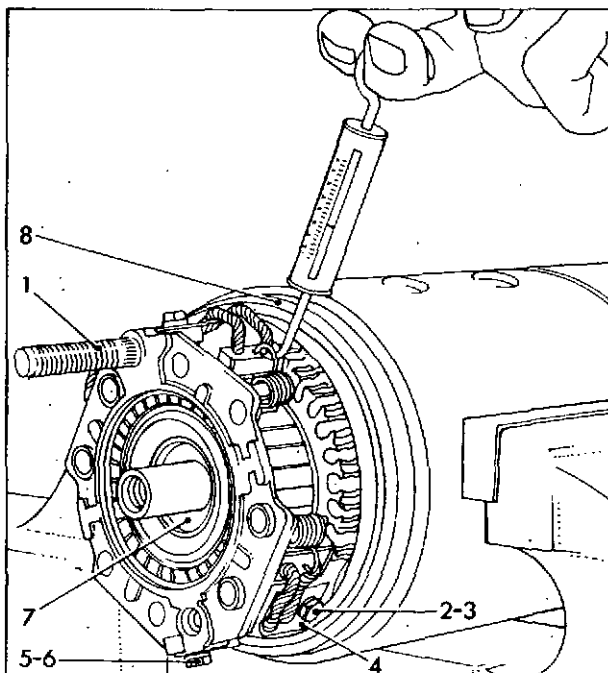

Fig. 26 Replacing brushgear

Smear the bush and the end of the armature shaft With 'Turbo 41' oil.

Assemble the end shield (1) fig. 27 onto the yoke, ensuring that it is correctly located and the brush leads are not trapped.

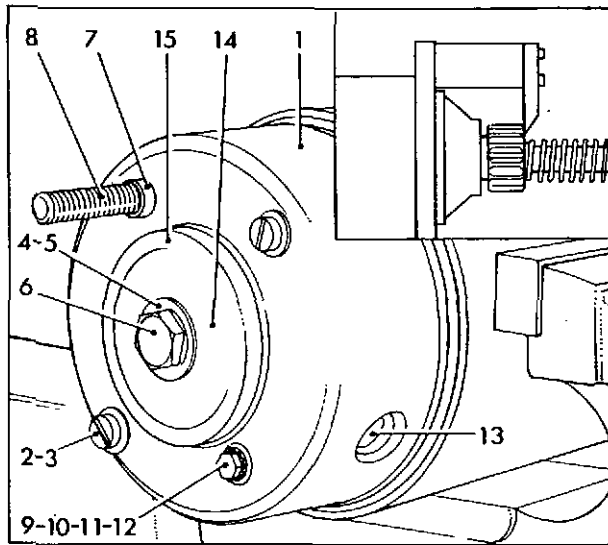

Fig. 27 Replacing commutator end shield

Insert both through bolts (2) with sealing washers (3) and tighten to torque value of 9.5 to 10 lbf.ft (12.9 to 13.6 Nm).

Check the pinion to flange clearance, using gauge tool No. 5693-222, by holding the gauge firmly against the flange as shown in inset on fig. 27. With the pinion loaded slightly inwards the arm of the gauge should just clear the face of the pinion. To adjust this clearance add or subtract shims as necessary between the recoil housing and the end shield boss. Shims of varying thickness are available. Assemble shims (4) thrust washer (5) and bolt (6) and tighten the bolt to a torque value of 25 to 30 lbf.ft (34.0 to 40.7 Nm) while holding the pinion with tool No. 6244-39. Add or subtract shims as necessary to obtain a clearance of 0.004 to 0.012 in (0.1 to 0.3 mm) between thrust washer and the shims.

Hold the pinion and tighten the pinion stop nut to a torque value of 40 to 50 lbf.ft (54.2 to 67.8 Nm).

Slide bush (7) over return terminal (8) and press fully home.

Fit insulating bush (9), plain washer (10) shakeproof washer (11) and screw (12); tighten screw to torque value of 15 to 18 lbf.in (1.69 to 2.03 Nm). Pull on the return terminal (8) and tighten brush screws (13) through the access holes in the commutator end shield to a torque value of 15 to 18 lbf.in (1.69 to 2.03 Nm).

Remove both through bolts and fit felt washer (14) and seal (15). Place the commutator end shield cover (1) fig. 28 in position, refit both through bolts (2) with sealing washers (3) and tighten to torque value of 9.5 to 10 lbf.ft (12.9 to 13.6 Nm).

Fit the thin sealing washer (4), rubber seal (5), seal locator (6), plain washer (7), spring washer (8) and nut (9) on the return terminal; tighten to torque value of 9 to 10 lbf.ft (12.2 to 13.6 Nm). Add a second spring washer and nut to the terminal and screw up finger tight.

Insert the two field coil connecting screws, spring washers and plain washers through the holes in the drive end shield and tighten to torque value of 15 to 18 lbf.in (1.69 to 2.03 Nm).

Fit new core plug to each hole using tool No. 6244-45.

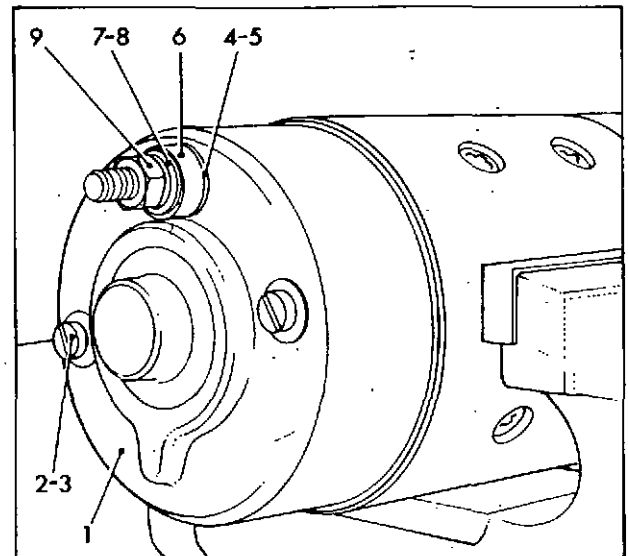

Fig. 28 Replacing commutator end shield cover

TESTING

Check that the pinion will rotate freely when turned by hand and will return easily to its original position when pulled partly outwards and then released.

Note: This check must be carried out before any power supply is connected to the main terminals. Failure to heed this warning could result in serious injury.

Light running test

Secure starter motor in a suitable position. Energise the solenoid with 24 volts and then connect a 24 volt battery supply to the main terminals for a maximum

of five seconds. The pinion should rotate slowly and smoothly with no undue noise or vibration. Disconnect the battery supply from the main terminals. Apply 24 volt to the solenoid terminals and pull the pinion forward into the locked position. Connect the main terminals to the 24 volt supply. In this position the pinion should rotate smoothly at a greater speed than previously

Disconnect the supply to the main terminals; the pinion should now return to its de-energised position and stop rotating.

Further details of testing may be obtained through an official C.A.V. agent.

PART 2—STARTER MOTOR**C.A.V. SP6A24**

Printed in Great Britain

DESCRIPTION

This is a 24-volt axial starter, actuated by an integral solenoid-operated two-stage switch.

Engagement between the pinion and flywheel is effected by a forward and rotational movement of the armature assembly, before the starter develops full torque.

An overload clutch, fitted between the armature and the pinion, has a slipping torque which is approximately twice the lock torque of the starter but less than the shear strength of the pinion teeth.

Referring to fig. 29, when the starter switch is operated the first stage contacts on the solenoid switch (18) close, and a small current passes through the auxiliary field windings, causing the armature to rotate slowly. Simultaneously, the armature assembly (35) is drawn towards the driving end by the magnetic field set up in the windings, and the pinion (39) meshes with the flywheel teeth.

As the armature nears the end of its travel the tripping disc (30) operates the trigger (19) on the solenoid switch, causing the second stage contacts to close and complete the circuit to the main series winding. The starter then exerts its full torque on the engine, and the overload clutch (36) will come into operation should the load be excessive.

When the starter button is released the armature is returned to the disengaged position by the coil spring on the armature plunger (32).

The auxiliary windings are arranged to hold the pinion in mesh until the starter button is released.

MAINTENANCE

In service the following periodic inspections of the starter should be made. Lubrication should not normally be necessary unless the starter is in use without overhaul for longer than three years.

Check the mounting bolts for tightness and the cables and their connections for security and damage.

Ensure that the bushes are free to slide in their holders, and check the tension of the brush springs. The pressure at the point of contact should be 32 to 40 oz. (0.91 to 1.13 kg.) and a reading of less than the lower limit indicates worn brushes. New brushes must be fitted as a set, and bedded to the commutator before the starter is used.

Inspect the insulation of the brush leads and ensure that they do not foul other components.

The surface of the commutator should be smooth and clean. A dark brown discoloration is normal and may be ignored. If necessary, any particles of dust should be removed by means of an air jet, and the commutator cleaned by holding a dry cloth against it whilst the armature is turned by hand. If the commutator is badly worn it must be removed and trued up in a lathe, as described under 'Inspection and Repair'.

REMOVAL AND DISMANTLING

Disconnect the leads at the motor terminals, remove the three setbolts from the starter flange and withdraw the starter motor.

Remove the commutator cover (29).

Unscrew the brush lead screws, lift the brush springs and remove the brushes from their holders. Removal

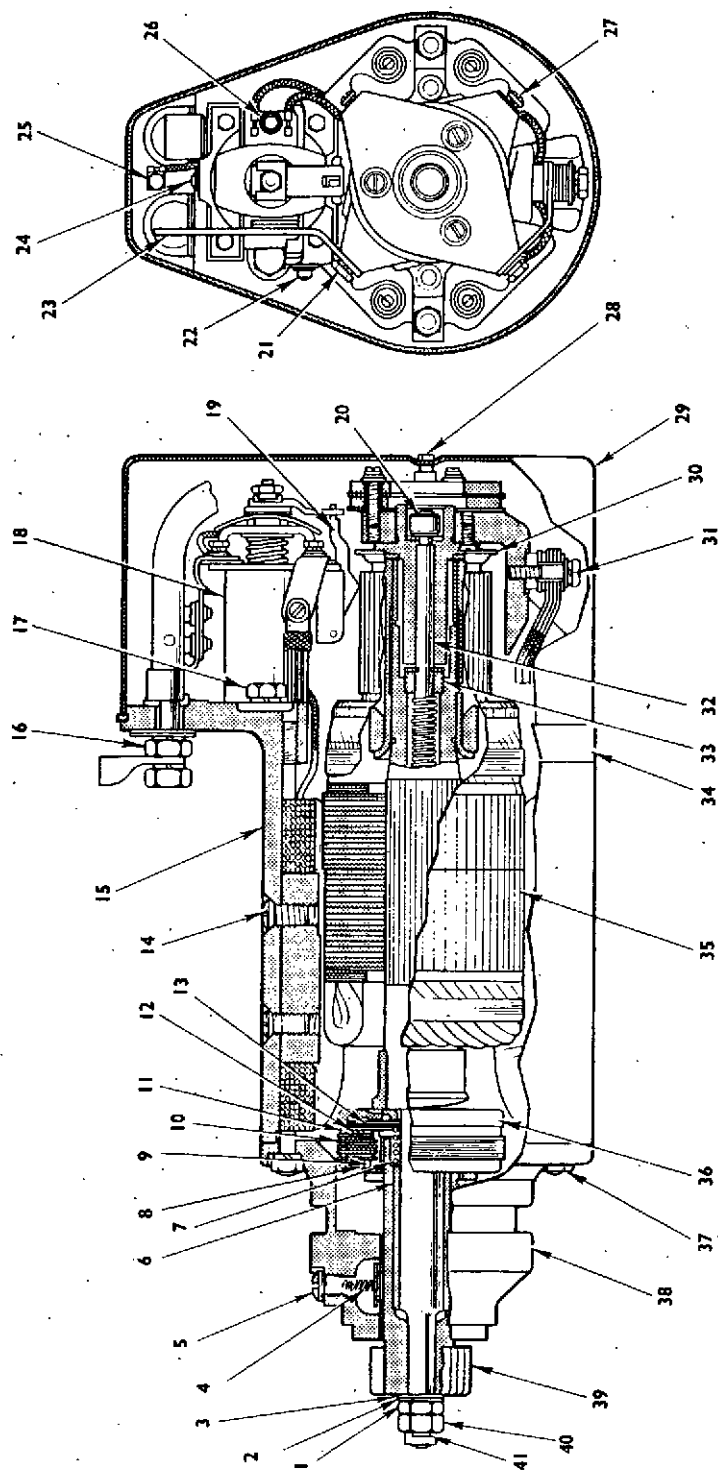

- | | | | |
|----------------------|----------------------------|----------------------------|---------------------------|
| 1. NUT | 11. SHIM WASHERS | 21. SCREW | 32. ARMATURE PLUNGER |
| 2. WASHER | 12. BACK PLATE | 22. SCREWS | 33. PLUNGER RETAINING NUT |
| 3. SHIM | 13. PRESSURE PLATES | 23. NEGATIVE CONNECTOR | 34. COMMUTATOR END SHIELD |
| 4. LUBRICATOR SPRING | 14. POLE FIXING SCREWS | 24. SCREWS | 35. ARMATURE ASSEMBLY |
| 5. LUBRICATOR 'PLUG | 15. YOKE | 25. SOLENOID COIL TERMINAL | 36. OVERLOAD CLUTCH |
| 6. SHIM | 16. NEGATIVE TERMINAL NUTS | 26. SCREWS | 37. OUTER RACE |
| 7. PINION SPRING | 17. SOLENOID FIXING SCREWS | 27. BRUSH LEAD SCREWS | 37. FIXING BOLTS |
| 8. CLUTCH INNER RACE | 18. SOLENOID SWITCH | 28. NUTS | 38. DRIVE END SHIELD |
| 9. CLUTCH SPRINGS | 19. TRIGGER | 29. COMMUTATOR COVER | 39. PINION |
| 10. CLUTCH PLATES | 20. NUT | 30. TRIPPING DISC | 40. NUTS |
| | | 31. SCREW | 41. SPLIT PIN |

14583A

Fig. 29 C.A.V. starter motor

of the brush lead screws also frees the auxiliary field connections to the brushgear.

Mark the leads to the brushgear and solenoid switch for ease of identification when assembling.

Remove the nut (20) from the armature plunger, using C.A.V. tool 5693/45.

Unscrew the main fixing bolts (37). Tap the drive end shield (38) away from the yoke (15), using a hide mallet, and withdraw the shield complete with armature (35).

Hold the armature in a soft-jawed vice and remove the lubricating plug (5) and spring (4) from the drive end shield.

Remove the split pin (41), nuts (40) and (1), and washers (2) and (3), and withdraw the pinion (39) and drive end shield from the shaft.

Remove the pinion spring (7).

Collect the clutch inner race (8), clutch plates (10), shims (11), back plate (12) and pressure plates (13) from the clutch assembly. Identify the clutch plates so that they may be reassembled in their original positions.

Withdraw the shim (6) and, if fitted, the rubber sealing ring from the pinion bore.

Using C.A.V. tool 5693/103, unscrew the armature plunger retaining nut (33) and withdraw the plunger (32) from the armature.

Remove the screws (22), (24) and (26) securing the positive terminal collector, main field coil ends and auxiliary field connections to the solenoid switch.

Remove the screw (31) holding the main field connections to the connection at the bottom of the commutator end shield, and carefully tap the end shield away from the yoke, using a hide mallet.

Disconnect the solenoid coil leads.

Unscrew the negative terminal nut (16) and the screw (21) securing the negative connector to the brushgear, and remove the negative connector.

Unscrew the solenoid screws (17) and remove the solenoid switch.

INSPECTION AND REPAIR

Commutator

Inspect the surface for wear, scores, and uneven discoloration. If these conditions are not severe,

restore the surface by the use of very fine glasspaper (NOT emery cloth or carborundum paper). Use an air jet to remove all traces of abrasive.

Where this treatment would be inadequate, set up the armature in a lathe and skim the commutator, taking care that the surface is concentric with the bearings. Make the finest cut necessary to clean up the surface, using a very sharp tool.

After skimming the commutator, undercut the insulation between the segments to a depth of 0.032 in. (0.8 mm.) using a proprietary tool or ground-down hacksaw blade.

Finally, set up the armature in a lathe and take a fine finishing cut, using a diamond tool. Remove all traces of dust by means of compressed air.

Armature windings

Armature windings may be tested for continuity and short circuits by means of a 'growler'.

If it is necessary to renew the armature, transfer the clutch outer race (36) to the new item. Use C.A.V. tool 5693/61 to press the race from the unserviceable armature. To fit the race to the new armature, insert C.A.V. tool 5693/94 into the armature bore so that the press bears on the tool and not on the end of the commutator.

Field windings

Test the windings for short circuits to earth by means of mains test probes in series with a lamp on the live side. Apply one probe to the yoke and the other to the end of each winding in turn. If the lamp does not light, the insulation is intact.

Make an open circuit test by connecting an ohmmeter across each winding in turn. No reading indicates that the winding is faulty.

Test each winding for internal short circuits by means of a low-reading ohmmeter.

To renew unserviceable coils, unscrew the pole fixing screws (14) and withdraw the poles and windings, noting the position of the windings to facilitate reassembly.

Fit the new windings to the poles and assemble them to the yoke so that the number on each pole corresponds with that on the yoke, and the step machined on each pole is towards the commutator end.

Warm the assembly in an oven and tighten the pole-screws with a proprietary pole-screw driver. Check by feeler gauge that there is no clearance between the mating surfaces of poles and yoke.

Bearings

Insert the pinion into its bearing in the drive end shield, fit the commutator end of the armature to the bearing pin in its end shield and check both bearings for excessive side-play.

A worn bearing pin at the commutator end, or a worn drive end bearing, will necessitate replacement of the respective end shield assembly, since renewal of these bearings entails the use of equipment not normally available.

Brushgear

Check the insulation between the following points, using mains test probes and lamp. The lamp should not light if the insulation is sound:

- (a) Between positive and negative brush holders.
- (b) Between positive brush holder and the frame.
- (c) Between negative brush holder and the frame.

Clutch

Unless facilities are available for testing the slipping torque, it is inadvisable to renew individual components, and a replacement assembly should be obtained if the clutch is unserviceable.

Instructions for adjusting the slipping torque are given under 'Assembling'.

Pinion

Examine the teeth for wear and damage. If a replacement pinion is to be fitted ensure that it has the same number of teeth and is of the same material as the old component.

ASSEMBLING

Grip the armature in a soft-jawed vice, grease the spring and thrust washer on the armature plunger (32), insert the plunger into the armature and tighten the retaining nut using C.A.V. tool 5693/45.

Insert the pressure plates (13), back ring (12) and shims (11) into the clutch outer race (36). Grease the clutch springs (9) and fit them, large end first, into their holes in the inner race (8).

Lightly grease the clutch plates (10) and, commencing with a steel plate fit alternate steel and bronze plates to the splines of the inner race. Assemble the inner race to the outer race.

Grease the pinion spring (7) and fit it to the armature shaft.

Grease the bore of the pinion (39), insert the rubber sealing ring, where fitted, and shim (6) and fit the pinion to the drive-end shield (38), rotating the pinion in the direction of its thread to avoid damaging the lubricating pad.

Assemble the pinion and drive-end shield to the armature shaft. Push the pinion forward and engage it with the internal thread of the clutch inner race. Hold it in this position and fit the shim (3), washer (2) and nut (1). Ensure that the shim is located over the shoulder of the shaft, and tighten the nut. Check that the pinion has a small amount of end float in the armature shaft.

CLUTCH ADJUSTMENT

To adjust the slipping torque of the clutch secure the armature in the clamp bracket 5693/62, and fit the torque bar 5693/147 to the pinion so that the torque is applied against normal starter rotation.

Adjust the clutch, by means of the shims (11) between the clutch plates (10) and the back plate (12), until it will support a weight of between 36.6lb. (16.6kg.) and 42.7lb. (19.4kg.) at the end of the torque bar. This will give a slipping torque of between 120 lbf.ft. (163 Nm) and 140 lbf.ft. (190 Nm).

Shims are supplied in 0.004 in. (0.1 mm.) and 0.006 in. (0.15 mm.) thickness, and adding shims will increase the slipping torque.

Slip the clutch ten times and then re-adjust it until it will support a weight of between 30.5lb. (13.8kg.) and 36.6lb. (16.6kg.) at the end of the torque bar. This will give a slipping torque of between 100 lbf.ft. (136 Nm) and 120 lbf.ft. (163 Nm).

Fit, tighten and lock the castellated nut (40).

Pour approximately 12 c.c. of oil into the filler hole in the drive end shield. When this has been absorbed by the pad replace the spring (4) and plug (5) and wipe off any surplus.

Fit the solenoid switch (18) to the commutator end shield, using the screws (17).

Assemble the negative connector (23) to the commutator-end shield, and fit the nuts (16) and screw (21).

Reconnect the solenoid winding leads.

Fit the commutator-end shield to the yoke, ensuring that the dowel is engaged.

Replace the screws (22) (24) and (26) securing the main field coil ends, positive terminal connector and auxiliary field connections to the solenoid switch.

Replace the screws and insulating pieces (31) holding the main field connections to the connector at the bottom of the commutator-end shield.

Assemble the armature and drive-end shield to the yoke, and fit and tighten the fixing bolts (37).

Ensure that the armature is free to rotate.

Fit and tighten the washers and nut (20) to the armature plunger.

Replace the bushes, ensuring that each returns to its original position. New brushes must be bedded in to the commutator.

Connect the brush leads and auxiliary field leads to the brushgear.

Referring to fig. 29 and fig. 30, check the relationship of the trigger (19) and tripping disc (30) by pulling the armature forward until the trigger is raised to its highest extent by the tripping disc. There should then be an adequate clearance ('X') between the shoulder on the trigger and the bottom of the slot in the catch plate.

TESTING

To test the engagement mechanism, insert a strip of insulating material between the second stage contacts of the solenoid, connect the starter to a battery, and press the starter button. The first stage contacts should close, causing the pinion to rotate in the normal direction and move forward approximately 1 inch (25.4 mm.).

Do not keep the starter button depressed for longer than necessary, otherwise the auxiliary windings may overheat.

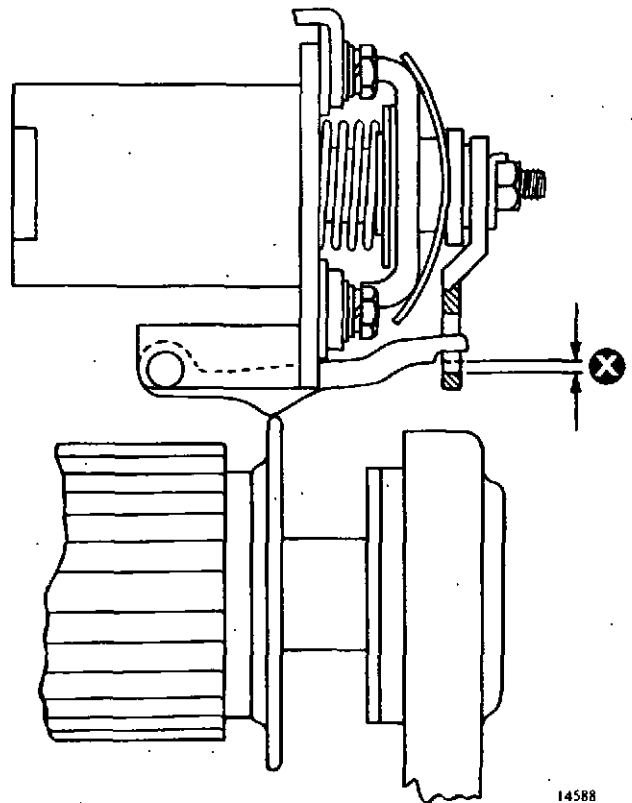

Fig. 30 C.A.V. solenoid trigger

LUBRICATION

For the drive-end bearing a good quality oil is recommended. Use S.A.E. 10W/30W in temperate climates or 5W/20W in sub-zero climates.

For other points, such as the clutch plates and springs, use Shell Nerita grease, BP Energrease or Shell Retinax H.

SPECIAL TOOLS

Rolls-Royce No.	C.A.V. No.	Description
OD.6725	5693/45	Key for plunger nut
OD.13085	5693/61	Extractor, clutch outer race
OD.13086	5693/62	Clamp bracket and shims for adjusting clutch
OD.13087	5693/94	Dolly, clutch housing
OD.13088	5693/103	Key, plunger stop
OD.13089	5693/147	Torque bar for adjusting clutch

Printed in Great Britain

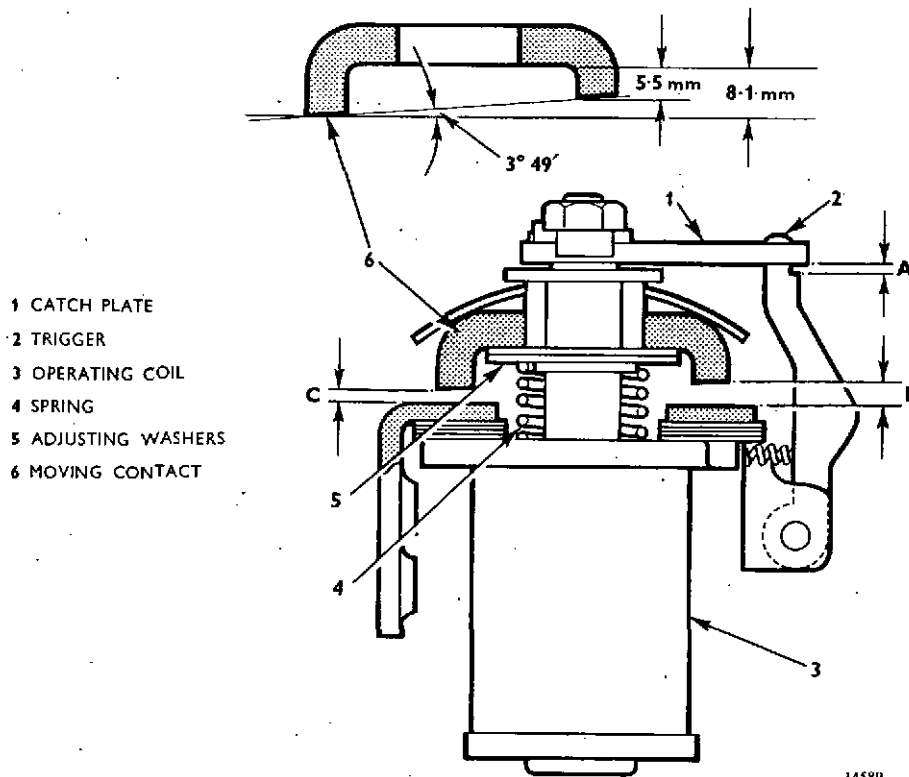

Fig. 31 C.A.V. solenoid switch

SOLENOID SWITCH—C.A.V. BBNG

This is a two-stage unit consisting of an operating coil assembly and two pairs of contacts, and is mounted on the end flange of the starter housing.

Referring to fig. 31, when the starter button is pressed, the solenoid operating coil (3) is energised, drawing in the solenoid plunger until the catchplate (1) rests on the trigger (2) and the first-stage contacts are closed.

As the armature travels forward, engaging the pinion with the engine flywheel, the tripping disc lifts the trigger, allowing the plunger to move fully home and close the second-stage contacts.

The switch will remain in this position until the starter button is released, when the coil spring (4) will return the plunger and moving contact to their original position.

Dismantling and inspection

Remove the nut and tabwasher, catchplate (1), contact guide and leaf spring, and withdraw the moving contact (6).

The contact points may be cleaned with spirit or very fine carborundum paper. If badly burned or pitted they may be refaced in a lathe, but not more than 0.020 in. (0.5 mm.) may be removed.

The faces of the moving contact are inclined at an angle of 3 deg. 49 minutes, and this angle must be maintained when refacing.

The fixed contacts are finished squarely and must be refaced whilst in position on the switch. New fixed contacts are supplied unmachined and must be similarly faced in position.

In the absence of machining facilities, or if the solenoid windings are defective, the switch must be replaced.

If the catchplate and trigger are worn they should be renewed.

Assembling

Apply petroleum jelly sparingly at the junction of the solenoid plunger and the switch body, and also where the leaf spring bears on the moving contact.

Assemble the components in the reverse order of dismantling, but do not lock the securing nut at this stage.

Referring to fig. 31, check contact gaps B and C. Limits are:

Gap B: 0.132 to 0.148 inch (3.4 to 3.8 mm.)

Gap C: 0.354 to 0.433 inch (9.0 to 11.0 mm.)

Adjust if necessary by washers (5) which are supplied in varying thicknesses.

Similarly, check gap A between catchplate and trigger shoulder. Limits are 0.076 to 0.084 inch (1.9 to 2.1 mm.).

Finally, lock the securing nut.

Testing

Measure the force required to overcome the return spring, applied at the tip of the plunger. Limits are 4lb. 11 oz. to 5lb. 5 oz. (2.250 kg. to 2.350 kg.).

Measure the force required to overcome both the return spring and the contact spring, applied at the tip of the plunger. Limits are 25lb. to 29lb. (11.34 kg. to 13.15 kg.).

Measure the force required to overcome the trigger spring, applied at the peak of the tripping face with the switch in the OFF position. Limits are 7.5 oz. to 10.5 oz. (0.20 kg. to 0.30 kg.).

Ensure that both contacts close when a potential of 15 volts is applied to the solenoid winding.

ROLLS-ROYCE DIESELS



PART 3—ALTERNATOR

C.A.V. AC5R

DESCRIPTION

The AC5R alternator has a built-in regulator fixed to the slip ring end shield. The regulator has solid state circuits throughout with the transistors, diodes and resistors mounted on a printed circuit board contained within a special moulding to provide maximum protection. The regulator requires no adjustment during service and is a non-repairable item which must be renewed if found to be faulty.

DISMANTLING

Before dismantling the unit thoroughly clean the alternator using a cloth or brush dipped in kerosene or a suitable cleaning fluid.

It is necessary before commencing dismantling or repairs on the alternator to determine whether the alternator or the regulator is at fault. This may be achieved by the following procedure:

1. Remove the alternator end cover and disconnect the lead from the 'F' terminal on the alternator brush box.
2. Connect a lead from the 'F' terminal on the brush box to the - connection on the alternator.
3. Wire the + and IND connections on the alternator with a lamp and switch as shown in fig. 32. Check the lamp and switch before test. With the switch closed the lamp will light if the regulator is faulty, and will not light if the alternator is faulty.

WARNING: Do not remove any connections while the alternator is running.

Regulator

1. Alternator end cover already removed for fault finding.
2. Mark up the regulator leads and relevant connections, and disconnect leads.

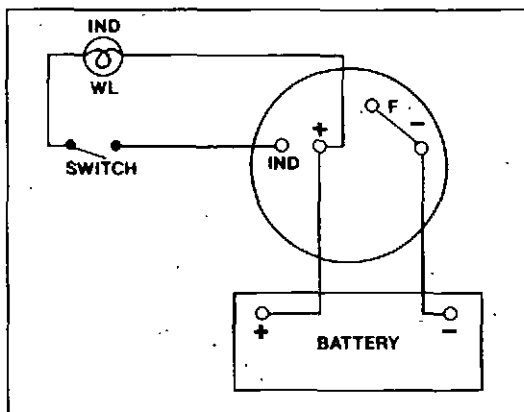

Fig. 32 Test circuit

24887

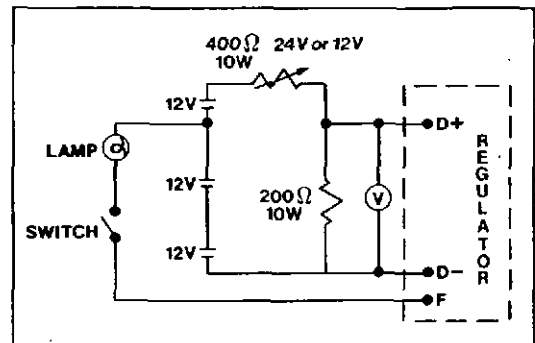

Fig. 33 Regulator test circuit

24888

- Remove lower left hand retaining pillar together with the washers and withdraw the regulator from the slip ring end shield.

In order to dismantle, assemble or test the alternator only, follow the instructions as detailed for the AC5/24 alternator.

INSPECTION AND RENEWAL

Regulator

Thoroughly clean the regulator and Lucar connections and examine visually for signs of cracking or other damage. A new regulator must be fitted if any damage is observed.

Testing. Wire the regulator to the warning lamp, on/off switch, voltmeter, variable resistance and a 36 volt supply, as shown in fig. 33 and proceed with the following tests.

- Close the switch. If the lamp does not light the regulator is faulty and *must* be replaced.
- With the switch closed and the lamp lit, increase the voltage across D+ and D- to 28.5 volts. If the light remains lit the regulator is faulty and *must* be replaced.

Assembly. Position the regulator on the slip ring end shield with the wiring leads on the inner side and line up the locating holes. Secure in position with the pillars and tighten to 15 to 20 lbf.in (1.7 to 2.3 Nm) torque value. Ensure that all connections are in the same positions as noted when dismantling. Secure the end cover in position with screws and washers and tighten to 12 to 15 lbf.in (1.4 to 1.7 Nm).

When checking the alternator output ensure that the battery is not in a fully charged condition, thus preventing the voltage regulator tapering off the alternator output and the following figures being achieved.

Type of Alternator	Cutting-in Speed rpm	Current output at 2000 rpm	Current output at 3000 rpm	Current output at 4000 rpm
24V	1250 at 28 volts	16.5 Amps	25.5 Amps	29 Amps

Variations from the stated output is permissible, but failure to reach within 10% of the stated figure indicates a faulty regulator.

PART 4—ALTERNATOR

C.A.V. AC5/24

DESCRIPTION

Alternator

The alternator is a 3-phase star-connected machine of the revolving field and stationary armature type, self-limiting in current output.

Rectification is by six silicon diodes, mounted in heat sinks in the slip ring end shield and connected in a 3-phase bridge circuit between stator and output terminals. To prevent the battery discharging through the field coil when the alternator is stationary, three auxiliary diodes are used in conjunction with three of the main diodes to form a second rectifier bridge.

The rotor is carried in sealed ball bearings housed in the end shields, a fan at the driving end directing cooling air through the alternator. The two brushes are housed in a moulded box, mounted on the slip ring end shield.

Alternator limitations are as follows:

Cut-in speed (alternator rpm)	1125
Max. output (hot) at 27.5 volts	31 amps
Max. speed (alternator rpm)	10,000

Voltage regulator (Control board)

The Type 440 regulator is fully transistorised. It is sealed and cannot be serviced, adjusted or repaired. Three terminals, marked 'HI', 'MED' and 'LO', are provided to permit a change of setting to suit varying operating conditions.

DISMANTLING

1. Remove the baffle or cowl from the slip ring end shield, disconnect the brush leads and remove brush assembly.
2. Unscrew pulley nut and withdraw pulley and fan.
3. Mark both end shields and the stator to ensure correct alignment on assembling.
4. Remove the three through-bolts and carefully withdraw the drive end shield.
5. Place the stator, slip ring end shield uppermost, on a bench and unsolder the three stator phase leads from the heat sink terminal tags. Do NOT remove the tags from the heat sinks. Separate

the slip ring end shield from the stator, and extract the 'O' ring from the end shield bearing housing.

6. Support the drive end shield and carefully press out the rotor.

INSPECTION

1. Clean rotor shaft and stator, using a cloth moistened with white spirit. Blow off dirt and carbon dust from all parts.
2. Check slip rings for concentricity and wear. Correct by skimming if necessary, but do not reduce their diameter below 1.136 inches (28.85 mm.).
3. Inspect the brushes, and renew them if their length is less than $\frac{5}{16}$ inch (7.9 mm.).
4. Check bearings for wear and renew if necessary.

ELECTRICAL TESTS

Rotor

Test the insulation between each slip ring and the rotor shaft. Minimum acceptable resistance is 10 megohms.

Measure the resistance between slip rings. Limits are 9.4 to 9.8 ohms.

Stator

Test the insulation between stator frame and any terminal tag. Minimum acceptable resistance is 10 megohms.

Connect the stator leads, in pairs, to a 20 amp DC supply and check that the voltage drop in each case is 8.4 volts.

Diodes

Connect a test probe, in series with a 48-watt 24-volt lamp, to the positive terminal of a 24-volt DC supply. Connect another test probe to the negative terminal. Carry out the tests listed in the following table. Faulty diodes must be renewed, together with their heat sinks.

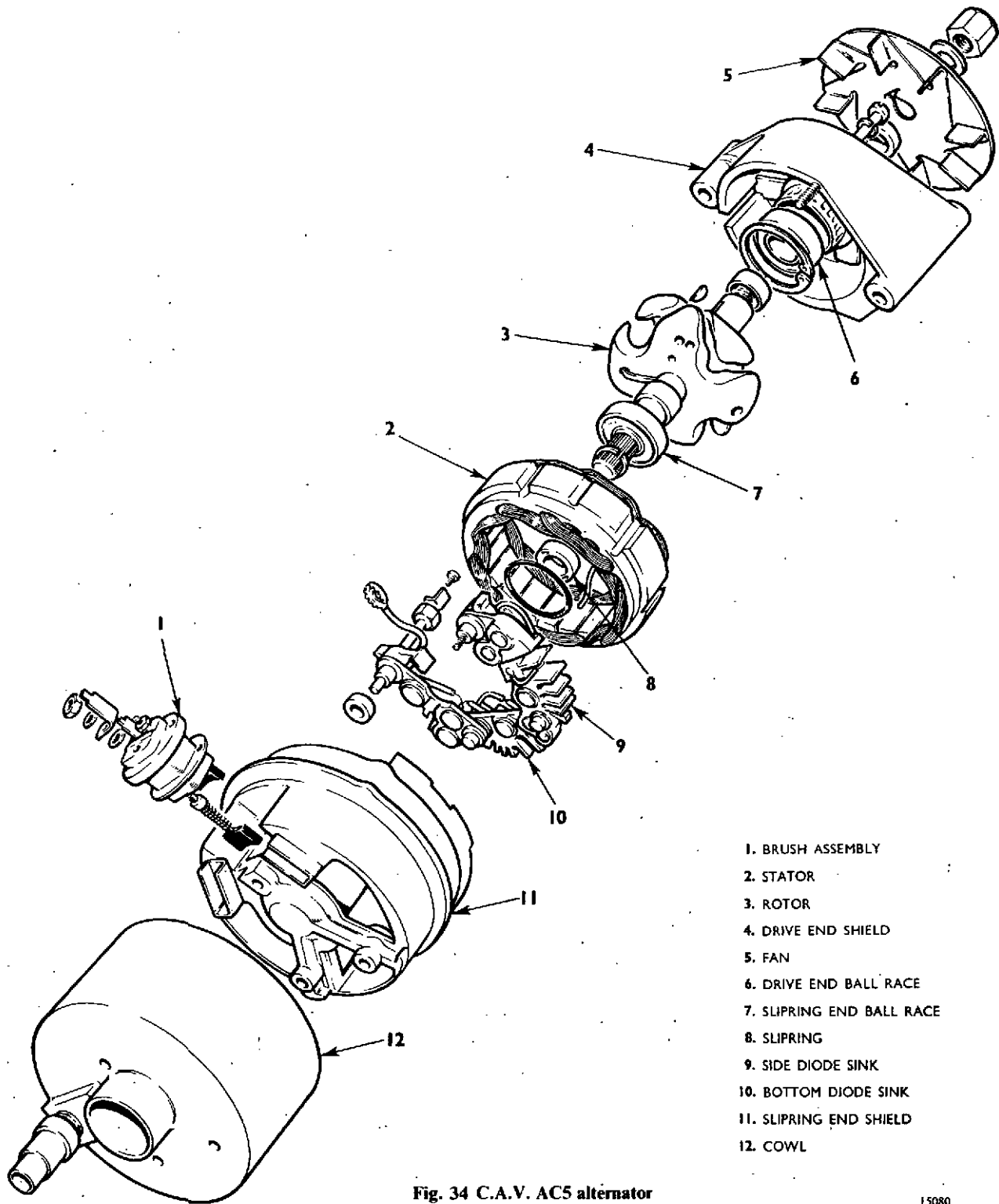

- 1. BRUSH ASSEMBLY
- 2. STATOR
- 3. ROTOR
- 4. DRIVE END SHIELD
- 5. FAN
- 6. DRIVE END BALL RACE
- 7. SLIPRING END BALL RACE
- 8. SLIPRING
- 9. SIDE DIODE SINK
- 10. BOTTOM DIODE SINK
- 11. SLIPRING END SHIELD
- 12. COWL

Fig. 34 C.A.V. AC5 alternator

15080

Test	Test lead conn. (+)	Test lead conn. (-)	Diode under test	Result if serviceable
1	Each heat sink in turn	D+	Positive	Lamp lights
2	D+	Each heat sink in turn	Positive	No light
3	D-	Each heat sink in turn	Negative	Lamp lights
4	Each heat sink in turn	D-	Negative	No light
5	Each heat sink in turn	A	Auxiliary	Lamp lights
6	A	Each heat sink in turn	Auxiliary	No light

ASSEMBLING

- Position the stator with phase leads uppermost and carefully lower the slip ring end shield on to it, aligning the locating marks made on dismantling. Solder the stator phase leads to the heat sink tags.
- Assemble the spacer to the rotor shaft, and press the rotor into its bearing in the drive end shield.
- Fit the slip ring end shield/stator assembly squarely to the drive end shield/rotor assembly, aligning the locating marks as before. Fit the three securing bolts, with 'Loctite' grade A on their threads, and tighten them evenly to 45 lbf.in. (5.1 Nm) whilst carefully tapping the assemblies together.
- Fit the brushes to their box and assemble the brushgear to the slip ring end shield, using a new joint gasket.
- Refit the baffle or cowl to the slip ring end shield.
- Fit the fan, with spacer if applicable. Assemble the Woodruff key (together with any spacing washers fitted for pulley alignment), fit the pulley and tighten its nut to 40 lbf.ft. (54 Nm). To retain the pulley whilst tightening the nut, use strap wrench GA.481.

BENCH TEST

The following equipment is required:
 Variable speed drive, up to 10,000 rpm
 24-volt battery
 Variable load, up to 60 amps
 Control board, Type 440
 0-50 moving coil DC voltmeter
 0-100 moving coil DC ammeter
 110-volt non-destructive flash tester or megohm meter.

1. Test for earths, using the flash meter or megohm meter as follows and taking care always to keep one probe on the frame. Minimum insulation resistance 10 megohms:
 - (a) D+ and earth
 - (b) D- and earth
 - (c) 'A' terminal and earth.
2. Assemble the alternator to its drive and make all connections to battery and control board, with a 24-volt, 2-watt lamp in series with a switch in the circuit. Connect the ammeter in the positive line. The variable resistance, with switch in series, is connected across the battery.
3. Close the switch in series with the warning lamp. The lamp should light.
4. Start the drive and increase speed until warning lamp goes out, indicating alternator charging. This should occur below 1500 rpm.
5. Reduce speed to 1125 rpm and measure voltage between WL and + on control board. This should be between 24 and 28 volts.
6. (a) Connect voltmeter between B+ and B-. Apply 20 to 30 amp load to battery and, with alternator running at 3200 rpm, check that ammeter reading is 28 to 31 at a voltage of 26 to 27.
 - (b) Increase speed to 10,000 rpm and check that ammeter reads 30 to 35 at voltage of 26 to 27.
 - (c) Adjust battery load as necessary. Run alternator at 10,000 rpm for one minute.
7. Reduce speed to 3000 rpm and switch off loads across battery. Voltage should rise to between 26 and 28 and then remain constant, whilst the current reading should fall appreciably. At 15 amps the voltage reading from the MED terminal should be between 27.25 and 27.75 volts; the readings from HI and LO terminals are one volt on either side of this.

SECTION 15—RUNNING-IN AND STORAGE

RUNNING-IN

Every new or reconditioned engine supplied by Rolls-Royce is run-in before leaving the factory and requires no special treatment when put into service, except that the user is recommended to follow the operating instructions given in the Engine Servicing Manual T.S.D. 3126—Chapter 2.

When a 'Short Engine' has been built up and installed, or when a partial overhaul has involved replacement of cylinder liners and piston rings, the user is advised to carry out the following simple 'running-in' sequence before subjecting it to full load:

Note: Before running-in the engine refer to Section 13 for details concerning precautions adopted by Rolls-Royce Motors Ltd. to protect turbocharger bearings during running-in at the factory.

Prior to commencing the appropriate schedule:

- (a) Prepare the engine for running and start up as described in the Servicing Manual T.S.D. 3126, Chapter 2.
- (b) Start the engine, run it at 800 rpm and check that the correct oil pressure is registered steadily on the gauge. Inspect all systems for leaks. Shut down engine and, if necessary, top up the coolant and lubricating oil systems.
- (c) Start up the engine and run-in according to the details given in the appropriate following table:

Engines rated at 1500 rpm

RPM	Load	Duration (minutes)
1000	Minimum	5
1200	Minimum	5
1200	25%	5
1200	50%	5
1500	50%	5
1500	75%	5
1500	100%	10

Engines rated at 1800 rpm

RPM	Load	Duration (minutes)
1000	Minimum	5
1200	Minimum	5
1200	25%	5
1500	25%	5
1500	50%	5
1800	50%	5
1800	75%	5
1800	100%	5

Engines rated at 2100 rpm

RPM	Load	Duration (minutes)
1000	Minimum	5
1500	Minimum	5
1500	25%	5
1800	25%	5
1800	50%	5
2100	50%	5
2100	75%	5
2100	100%	5

Engines in constant speed installations

- (d) These engines are generally connected to their driven equipment by a flexible coupling, and at certain critical speeds the assembly may have torsional characteristics detrimental to its various components.

For this reason it is preferable for an engine to be run-in on a test bed, using the appropriate 'variable speed' schedule previously described, before being installed.

If this is not practicable the engine must necessarily be run-in under working conditions, i.e. at rated speed whilst coupled to its driven equipment, as follows:

RPM	Load	Duration (minutes)
Rated speed	50%	30
Rated speed	75%	60
Rated speed	100%	15

Printed in Great Britain

Checking oil consumption

Where practicable the following check schedule which is suitable for all applications, should be carried out. If this is not possible, the engine should be put to its normal use after running-in and a careful record of oil added kept over a reasonable period of running time (e.g. 100 hours), each dipstick reading and topping-up being made under identical conditions; i.e. engine stationary or running, hot or cold, whichever applies, consistently on each occasion.

Consumption check schedule

1. On completion of running-in, stop the engine. Inspect for leaks, particularly from the lubrication system, and rectify as necessary. Check the oil and coolant levels and top up as required.
2. Run the engine under minimum load for 5 minutes at 1000 rpm (variable-speed engines) or rated speed (constant-speed engines). Shut down and allow the engine to stand for 5 minutes.
3. Remove the sump plug and drain the oil into clean containers, of known weight, for exactly 15 minutes. Alternatively, if the sump can only be emptied by evacuation pump, continue pumping until no more oil is passed. (See Section 1 'Engine Data', for sump capacities).
4. Weigh the oil in the containers and return it to the sump.
5. Re-start the engine and run it at rated speed under 75% load for exactly 2 hours; at the end of this period:
 - (a) On variable speed engines, remove the load and reduce speed to 1000 rpm for 5 minutes.
 - (b) On constant-speed installations, remove the load and continue running at rated speed for 5 minutes.
 - (c) Following (a) or (b), as applicable, shut down and allow the engine to stand for 5 minutes.
6. Drain the oil into the same containers in exactly the same manner as previously (item 3), weigh it in the containers and return it to the sump. Calculate the weight of oil used and convert to pints or litres

as necessary. One Imperial gallon of lubricating oil weighs approximately 8.95lb, one litre weighs approximately 0.897kg.

Acceptable maximum oil consumption figures are:

Normally aspirated engines

0.60 pints (0.342 litres) per hour.

Turbocharged engines

0.90 pints (0.511 litres) per hour.

STORAGE

Short term

Up to seven days: No treatment is necessary.

Up to one month: Run the engine each week until working temperature is reached. If the engine cannot be run, turn the crankshaft for at least three revolutions.

Long term (maximum 12 months)

If it is necessary to store an engine for a period of 1 month to 12 months the following inhibiting process must be followed:

1. Drain the engine lubricating oil from the sump whilst the engine is warm; remove and drain the oil filter bowls.
2. Refill the filter bowls with PX4 rust preventative (obtainable from Croda Chemicals Ltd., Goole, North Humberside) and refit to engine. Fill sump to normal level with PX4.
3. Run the engine until the normal operating temperature is reached; connect engine fuel feed to a supply of PX4.
4. Run the engine at 1000rpm on minimum load for between 5 and 10 minutes. Stop the engine. Remove the injectors and immerse them in PX4.
5. Remove the rocker covers, set fuel stop to 'NO FUEL', and remove the turbocharger outlet duct, where applicable.
6. Motor the engine over using the starter and simultaneously spray PX4 into the inlet manifold until vapour emerges from each injector orifice. Spray the valve gear, insides of rocker covers and turbocharger outlet duct with PX4 and refit.

7. Spray 40ccs of PX4 through the injector orifice into each cylinder (using a suitable 'self-metering' spray gun), and refit the injectors.

CAUTION: The engine must not be rotated after this operation and must carry a prominent notice to this effect.

8. Drain the cooling system. Fit a standpipe to the coolant inlet and fill the system with a mixture of inhibited ethylene glycol/water until the solution issues from the outlet duct above the thermostat housing. The mixture must contain between 50% and 90% inhibited ethylene by volume. The system must now be allowed to stand for 15 minutes and then be thoroughly drained.

9. Drain the PX4 from the sump and attach a 'NO OIL' notice to the oil filler cap.

10. Brush coat all unpainted areas of the fuel pump, starter motor, alternator, flywheel and external control linkage, where fitted, with PX28 Wax Film (obtainable from Croda Chemicals Ltd.).

11. Spray the interior of the air cleaner with PX4 and seal off with mouldable wrap secured with tape.

12. Remove fan belts and wrap them in waxed paper. Pack them in a large polythene bag and secure them to the engine.

13. Seal off all orifices with mouldable wrapping paper, or plastic caps secured with adhesive tape.

For engines in storage for over 12 months, the above procedure should be carried out at 12 monthly intervals.

ROLLS-ROYCE MOTORS LIMITED

DIESEL DIVISION

SHREWSBURY, SHROPSHIRE SY1 4DP, ENGLAND

Telephone: 0743/52262 · Telex: 35171-2

Telegrams: 'ROYCAR', Shrewsbury

© *Rolls-Royce Motors Limited, 1981*

Subject to any existing rights of third parties, the information contained in this document is the property of Rolls-Royce Motors Limited and should not be copied (in whole or in part) or used for manufacture or otherwise disclosed without the prior written consent of the Company. (This does not preclude use by engine and equipment operators for normal instructional, maintenance or overhaul purposes.)

ISSUED BY ROLLS-ROYCE MOTORS LIMITED



WORKSHOP MANUAL

CV8 ENGINES

T.S.D. PUBLICATION 3130

ROLLS-ROYCE MOTORS LIMITED . DIESEL DIVISION
SHREWSBURY, ENGLAND

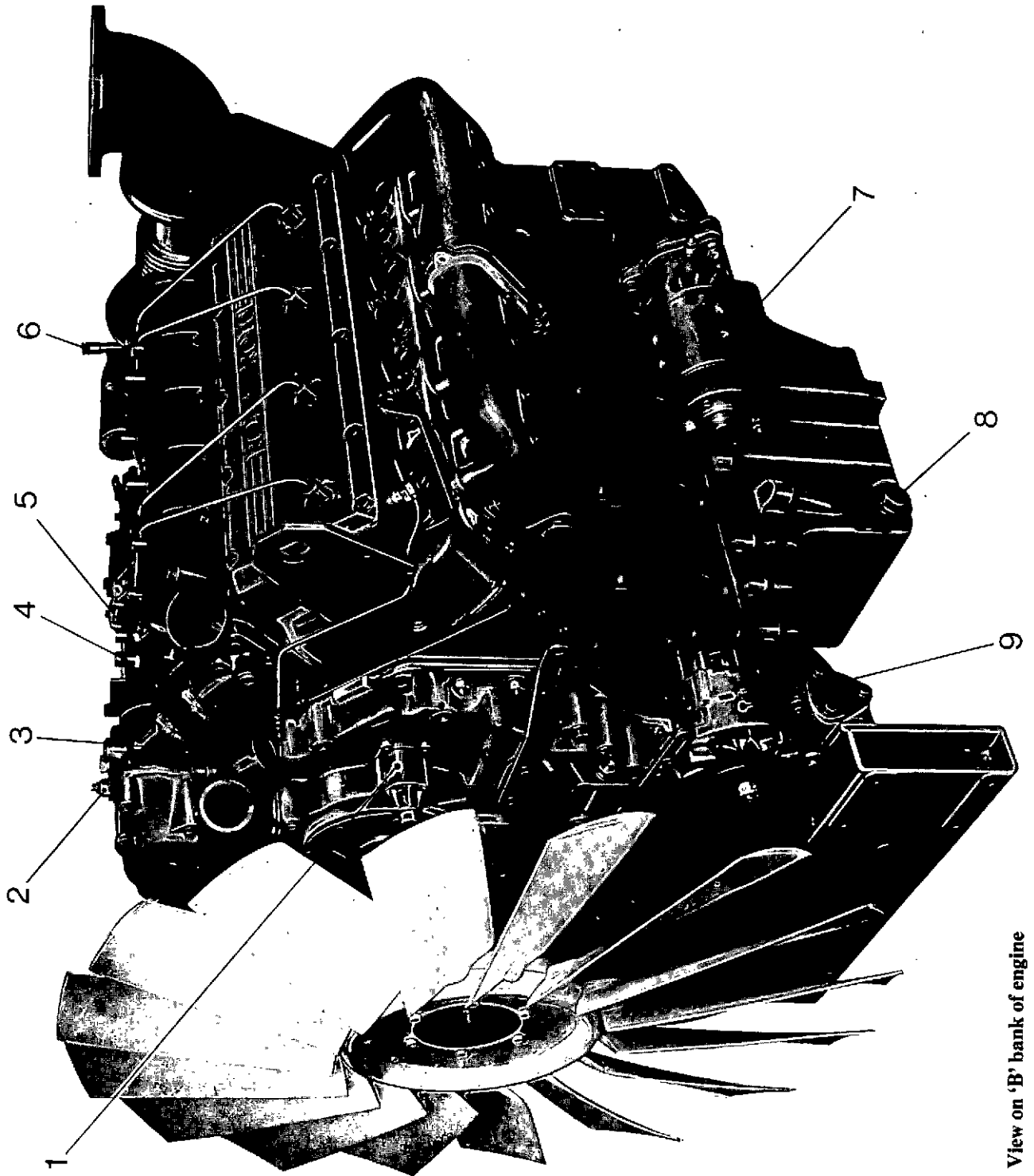

Fig.1 View on 'B' bank of engine

FRONTISPIECE

10. Oil filler
11. Injector gland nut
12. Fuel filter canister
13. Thermostat housing
14. Coolant pump
15. Oil pressure shutdown switch
16. Coolant drain cock
17. Lubricating oil filter canisters
18. Oil-to-coolant heat exchanger
19. Dipstick

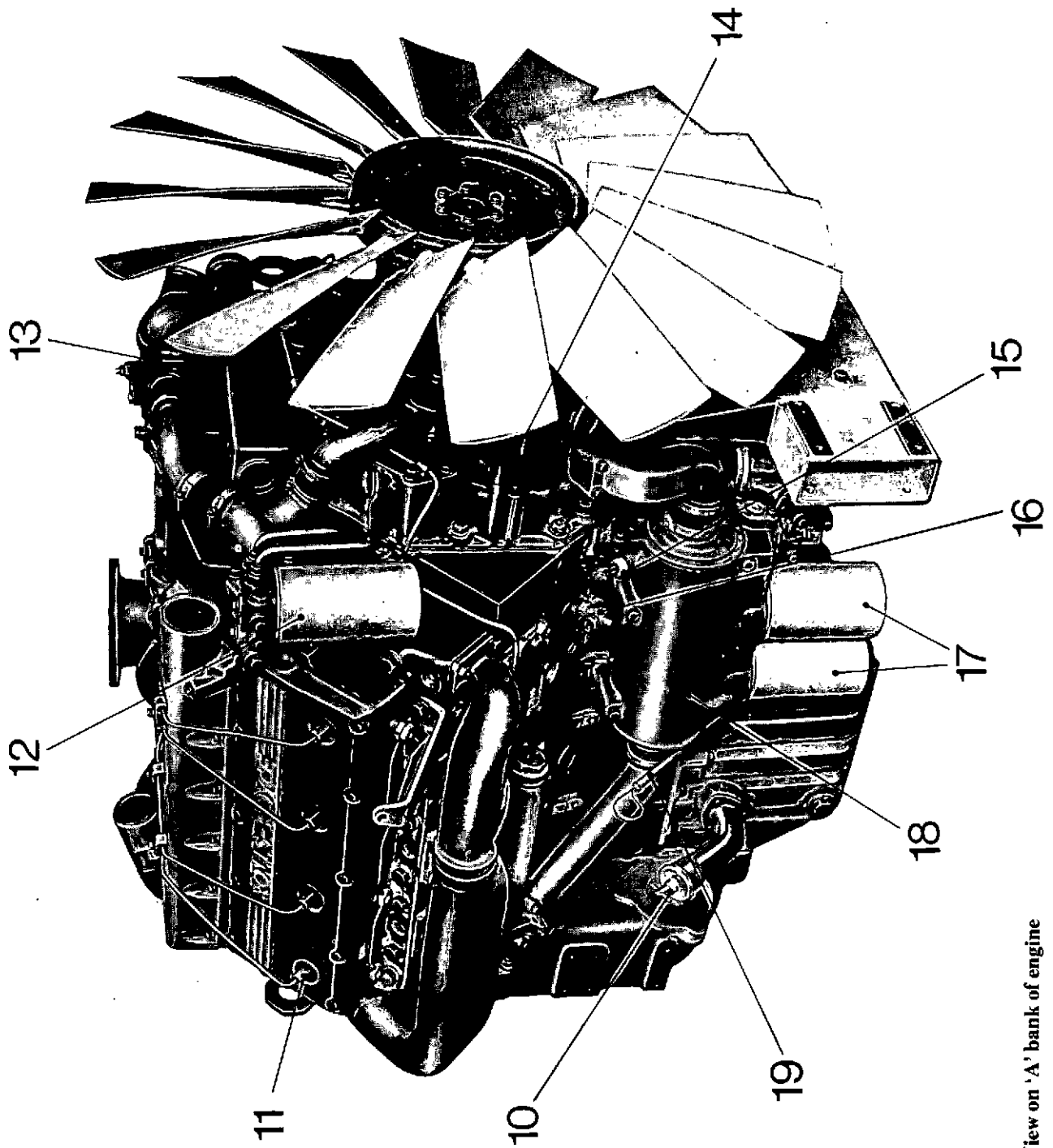

Fig. 2 View on 'A' bank of engine

NOTES TO USERS

Using and maintaining this Manual

The purpose of this Manual is to provide all the information necessary for the complete overhaul of Rolls-Royce CV8 diesel engines.

Due to the many versions of these engines and their varied applications, only those differences which affect basic procedures are mentioned specifically. Consequently, the illustrations and text may not always be identical in every respect to the corresponding arrangement on the engine being overhauled.

The information in this Manual is the latest available at the time of printing but continuing research and development work at Rolls-Royce Motors Limited will, from time to time, make it necessary to amend the text and/or the illustrations in the Manual to keep it up to date.

Service Instructions (C.V.I's) Changes in service techniques are issued as Service Instructions, in leaflet form, and sent in bulk to Dealers and Distributors for onward transmission to Operators.

Service Bulletins (C.V.B's) Engine design changes are issued as Service Bulletins, in leaflet form, and forwarded to Dealers and Distributors.

On receiving a C.V.I. or C.V.B., the user of the Manual should immediately endorse the relevant Section to keep the Manual in line with the latest developments.

Periodically, each Rolls-Royce technical publication is revised to include all relevant information from C.V.I's and C.V. B's distributed since the previous issue of the publication concerned. When this occurs, the revised publication is allocated the next consecutive Issue Number.

Information specifically concerning engines on which production has finally ceased is eventually, after several years, dropped from the Manuals to make room for new material. However, whilst these engines continue in service, it is Rolls-Royce policy to make every effort to maintain copies of this information.

Service

Throughout the world, Dealers and Distributors appointed by Rolls-Royce can provide advice, spare parts and Factory-trained staff. When necessary they can consult the area-based Rolls-Royce engineer or the Service Department of Rolls-Royce Motors, Diesel Division.

Advice and assistance can be more readily provided if enquiries are accompanied by the following:

1. In all cases, (a) the Engine Number, Designation and Build Number as stamped on the crankcase data plate, and (b) the operating units recorded by the Engine Service Counter (E.S.C.).
2. If a proprietary unit (e.g. injection pump, turbocharger) is involved, the details on its data plate and the number of operating units run.
3. Any other information logically connected with the subject, e.g. type of fuel, lubricating oil or coolant used, engine operating conditions, details of servicing history, etc.

To assist in reducing 'down time' to a minimum, Operators are recommended to make use of the established Service Exchange Scheme, details of which are given in this Section.

Instruction

A five day course on servicing and overhaul of CV8 engines is available at the Factory. For details apply to: The Superintendent, Customer Training Centre, Rolls-Royce Motors Limited, Diesel Division, Shrewsbury.

Associated Technical Publications for CV8 engines

T.S.D. 968	Service Reclamation Schemes	T.S.D. 3125	Essential Information for Operators
T.S.D. 3085	Fuel, Oil and Coolant Recommendations	T.S.D. 3128	Service Instructions
T.S.D. 3115	Servicing Manual	T.S.D. 3129	Service Bulletins
T.S.D. 3120	Operator's Guide		

SERVICE EXCHANGE SCHEME

The information in this Manual will assist the Operator in carrying out any work, from minor repairs to complete engine overhaul, on the CV8 range of engines. Occasionally, however personnel, equipment or time may not be available, which could result in delay before the engine returns to service. For this reason, Rolls-Royce Motors Limited have instituted a Service Exchange Scheme so that Dealers and Distributors can speedily supply a 'short engine' or major component, fully reconditioned at the Factory and guaranteed for six months. In certain circumstances, a reconditioned complete engine can be supplied.

The units available through the Scheme are listed below. Further details may be obtained from Dealers and Distributors; all enquiries should quote the Engine Number, Designation and Build Number, as stamped on the crankcase data plate. When applicable, the details on the data plate of a proprietary unit (e.g. turbo-charger) should be included.

AIR COMPRESSOR

ALTERNATOR

COOLANT PUMP

CRANKSHAFT

CYLINDER HEAD

FUEL INJECTOR

FUEL INJECTION PUMP (Complete)

FUEL FEED PUMP

LUBRICATING OIL PUMP

STARTER MOTOR

TURBOCHARGER

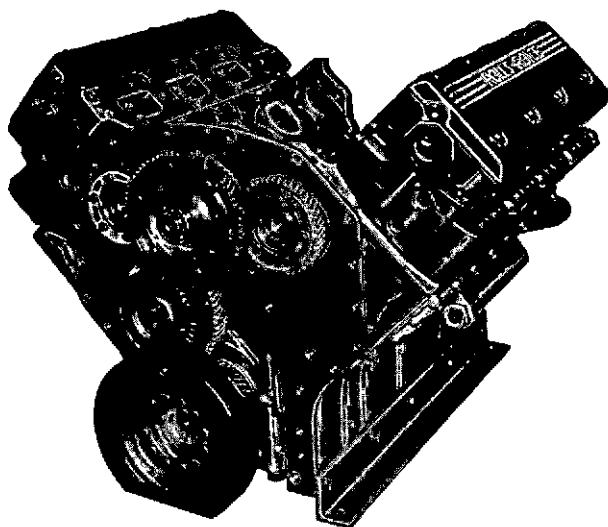

Fig. 1 Short engine, front view.

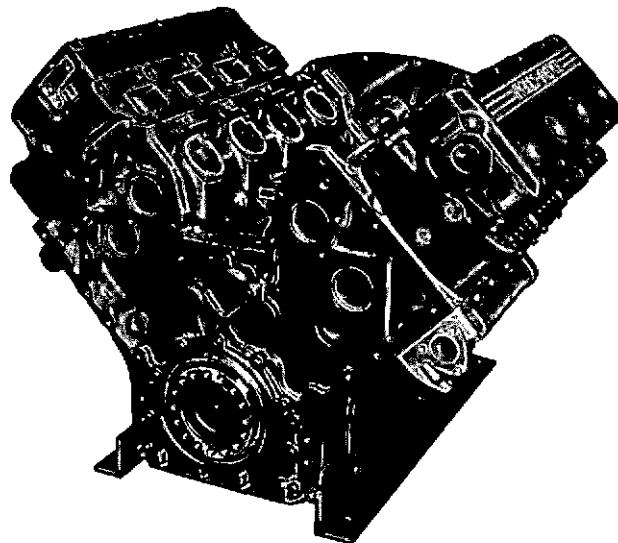

Fig. 2 Short engine, rear view.



CONTENTS

	Section
GENERAL INFORMATION	—
DESCRIPTION AND DATA	1
DISMANTLING THE ENGINE	2
ASSEMBLING THE ENGINE	3
CRANKCASE AND CYLINDER LINERS	4
CAMSHAFTS AND BEARINGS	5
CRANKSHAFT, MAIN BEARINGS AND FLYWHEEL	6
PISTONS AND CONNECTING RODS	7
CYLINDER HEADS AND VALVE GEAR	8
ROCKER BOXES	9
COOLING SYSTEM	10
FUEL SYSTEM	11
LUBRICATION SYSTEM... ..	12
INDUCTION/EXHAUST SYSTEM	13
ELECTRICAL EQUIPMENT	14
WHEELCASE, TIMING GEARS AND FAN ADAPTOR	15
RUNNING-IN AND TESTING	16
STORAGE	17

GENERAL INFORMATION

The following information, if kept in mind during repair or overhaul work, will ensure that the engine returns to duty in first-class order and can be relied upon to give long and trouble-free service, provided that it is properly used and maintained.

Cleanliness

The importance of this cannot be over-emphasised, particularly in respect of the fuel system. The ingress of dirt and foreign matter is a major cause of rapid wear, damage and engine failure.

During dismantling, first clean the vicinity of the component concerned, and ensure that all openings and disconnected pipes are blanked off without delay.

After removal, clean and inspect each component and, if serviceable, protect it against dirt, damage and corrosion until it is refitted. Special care is required with ball and roller bearings; after washing and inspection, they should be dipped in light-bodied oil and wrapped in clean paper.

When reassembling, take care that dirt does not enter the engine. Ensure that the atmosphere is as dust-free as possible, and inspect each component immediately before it is fitted. Wash all pipes and oilways, and blow through them with dry compressed air before making connections.

Special tools

These are provided for specific jobs and should be used, where recommended, to save time and prevent damage to parts. Where applicable, a list of relevant tools is given at the end of each Section.

Hose connections

Levering off a hose with a screwdriver causes damage to the adaptor or pipe. Cut through the hose with a sharp knife, and afterwards cut the ends from the adaptor pipe.

When fitting a new hose an approved rubber lubricant may be used as an alternative to glycol, water or French chalk (see Section 1). Never lubricate

a hose with oil or grease, which are injurious to rubber.

Gaskets, joints, and 'O' rings

It is false economy to re-use these items; their cost is trifling compared with the expense of rectifying leaks when the engine is back in service.

'Wellseal' compound is recommended for general use when making joints. As with any liquid jointing, it should be applied thinly to avoid the possibility of oilways and ducts being obstructed by excess compound.

'O' rings should be lightly lubricated to help prevent 'trapping' during assembly.

Locking devices

Used splitpins, lockplates and tabwashers must *never* be refitted. The correct method of fitting locking devices is shown in fig. 1.

All-metal stiffnuts may be re-used provided that they have not lost their efficiency, i.e. they still offer noticeable resistance to movement against normal spanner leverage. At least one full thread of the bolt or stud should protrude through a stiffnut when it is fully tightened.

Do *not* re-use stiffnuts having nylon or fibre inserts.

If spring washers have become flattened or their locking 'corners' rounded, thus impairing their efficiency, it is recommended that they be renewed.

Oil seals

Pack these with 'Vaseline' before fitting, and be careful not to cut the rubber on sharp edges. Unless otherwise specified, fit the seal with the wiping edge inwards to the bearing.

Torque loadings

These are specified for certain setbolts and nuts where defect or failure could result from incorrect

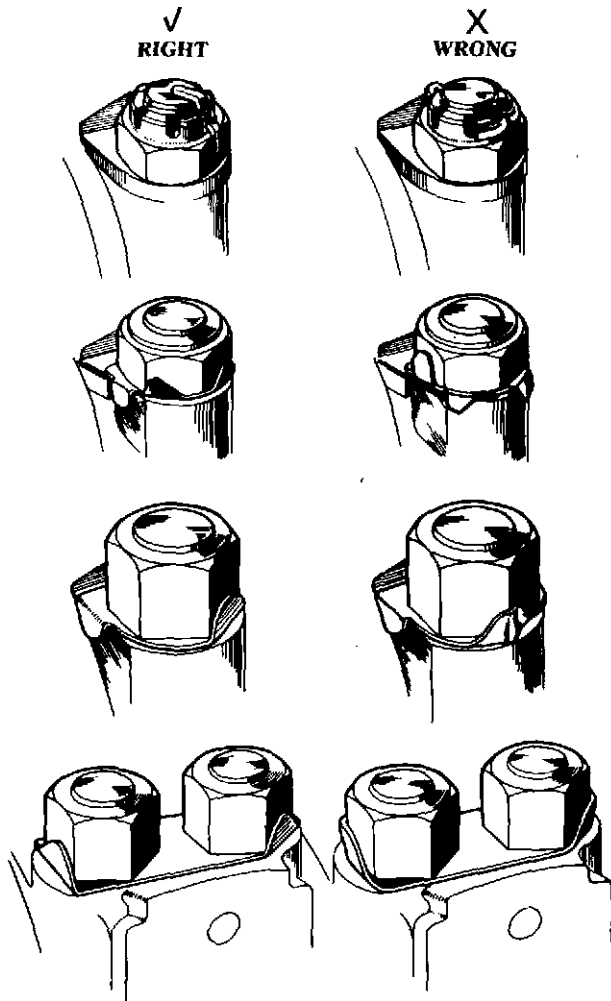

Fig. 1 Right and wrong methods of locking

tightness. For certain joints, such as cylinder head to crankcase, it is also essential that tightening is done evenly, progressively and in the correct order, to the instructions given in the assembly sequence.

Fits and clearances

At the end of each Section dealing with the inspection and assembly of an engine component will be found a table of relevant fits and clearances.

The dimensions given are such that a part falling within the limits is acceptable for a full period of service. Certain parts, worn beyond these limits, may be reclaimed under approved Repair Schemes which are circulated to authorise Dealers and Distributors.

Crack detection

Wherever possible, highly stressed components such as crankshafts, connecting rods, gear wheels and cylinder liners should be tested for cracks at overhaul periods or when they have been subjected to excessive loading or impact.

Ferrous components should be tested on an electromagnetic rig. Non-magnetic components, such as valves and pistons, may be tested by means of a dye penetrant. A recommended process is Ardrex 996, available from Ardrex Limited, Brentford, Middlesex.

Exchange units

Unserviceable units should be returned complete to the same standard as the replacement unit. All apertures should be blanked off, and joint faces protected. Where necessary, treat the unit internally and externally against corrosion.

Spares

To comply with the terms of the Rolls-Royce Guarantee, and to ensure maximum liability. **USE ONLY GENUINE ROLLS-ROYCE PARTS** supplied by the Factory or an accredited Dealer. These parts are manufactured to the latest specification and are **GUARANTEED** for six months.

Customers are **WARNED** against using non-genuine spares, notably filter elements. Such items may not conform to Rolls-Royce standards; their use may not only invalidate any current Rolls-Royce Guarantee, but seriously reduce engine life and performance.

SECTION 1—DESCRIPTION AND DATA

The Rolls-Royce CV8 is an eight cylinder, pressure-charged, direct injection, liquid cooled, four stroke, compression ignition engine in a 90 degree 'V' configuration.

Engine identification

The engine type, series and build number are printed on a data plate attached to the crankcase.

Proprietary units such as fuel injection pumps, turbochargers and starter motors carry their own data plates.

Bank and cylinder bore identification

Throughout this Manual reference is made to the 'A' bank and 'B' bank sides of the engine. For ease of identification the 'A' bank side is to the left and the 'B' bank side is to the right, when viewed on the front (free) end of the engine.

The cylinder units are numbered from the front to the rear (flywheel) end, A1 to A4 and B1 to B4.

Crankcase

The close-grained high duty iron crankcase is cast as a monobloc unit and dipped in a special compound to seal all non-machined surfaces against contamination.

The five main bearing caps of forged steel are each attached with two setbolts. Lateral security is effected by setbolts screwed into locating pads in the bearing caps, through the crankcase side walls.

The two banks of four cylinders, in a 90 degree included angle 'V' configuration, are in a conventional staggered pattern with 'B' bank leading.

Cylinder bores are machined to accept full length slip fit liners which are of centrifugally cast iron, machined to fine tolerances and pre-finished.

Crankshaft

The chrome molybdenum steel forged crankshaft is nitride hardened on all surfaces except the front and rear faces, the tapped and dowel holes and the oil thrower ring.

The nine bearing surfaces consist of five main journals

and four crankpins, each crankpin serving two connecting rods.

A conventional sludge trap is incorporated in the oilway of each crankpin, with an alloy plug in the crankweb to allow access for cleaning.

The rear end face of the crankshaft is drilled and tapped with 16 equally spaced holes to accept the flywheel securing screws. A spring dowel set in the crankshaft end face locates the flywheel on the crankshaft for timing mark alignment.

A 45 toothed helical gear is machined on the front end of the crankshaft to serve as the primary drive for the gear train.

The front end face is drilled and tapped to accommodate 12 equally spaced setbolts which secure the counterbalance and multigroove pulley to the crankshaft, the counterbalance being located by means of a spring dowel.

Main bearings

These are steel-backed, lead-bronze, half bearing shells with a lead indium plated inner surface.

The upper half of each bearing has an oil groove machined centrally around the inner surface connecting with a transfer hole which receives the lubricant supply from the crankcase oilway. A locating tang is pressed out from one end of the shell.

The lower half is similar but with shortened machined grooves. These correspond with the upper half groove for the transfer of lubricating oil to the lower bearing surface.

Thrust washers

Two steel-backed lead-bronze thrust washer halves are carried in machined recesses on either side of the centre main bearing support. Oil from the centre main bearing provides lubrication for the thrust washers, which have grooves machined across the faces to assist oil flow.

The lower halves of the thrust washers are similar but have an integral locating tang on one end.

Connecting rods

These are chrome-molybdenum steel forgings machined to accept steel-backed lead-bronze small end bushes and big-end bearing shells similar in composition to the main bearing shells. The small end is of wedge design to assist pressure loading of the small end bearing and piston.

A hole bored centrally through the column of each rod allows pressurised oil to be directed intermittently from the crank pin to the gudgeon pin and small end bearing.

Markings on each connecting rod assembly give rod to cap correlation, weight and when allocated, the cylinder bore number.

Pistons

Cast from high silicon aluminium alloy with the crown machined to form an open toroidal combustion chamber, each piston carries three compression and one oil control ring in machined grooves. The top ring is carried in an austenitic iron insert. Ring sequence is as follows:

- Top — Inlaid molybdenum surface
- Second — Chrome plated
- Third — Ferrox treated surface
- Bottom — Composite chrome plated oil control ring

Each piston is tin-plated on all surfaces after machining, apart from the gudgeon pin bore. The gudgeon pin is fully floating and is retained by the conventional circlip method.

Camshafts

Manufactured in a cast iron alloy, the unidentical camshafts have chill-hardened cam noses with precision machined tapers.

The two camshafts each have five bearing journals and are high mounted inside the 'V' of the crankcase. Thrust plates, bolted to the housing, position each shaft axially.

Both shafts, of the same overall length, are identified by the positioning of the cam lobes. Each pair of cam lobes on the 'B' bank camshaft is closer to the drive end than those on the 'A' bank camshaft, to accommodate the off-setting of the cylinder bores.

A flange on the drive end of each camshaft accepts the cam phasing gears, each secured with six setbolts and located by spring steel dowels. Drive is provided by the fuel injection pump compounded drive gear.

Collars machined on each camshaft at the drive-end serve as bearing surfaces for the thrust plates.

The bearings are steel-backed, lead-bronze bushes manufactured with clinch butt joints and are disposed singly in each bank. All bushes are drilled and grooved for lubrication, each bush being fed with pressurised oil via drillings from the auxiliary oil galleries.

Pushrods and tappets

The tappets, made of a cast iron alloy, are fully machined with chill-hardened bases and are treated to provide an oil retaining surface finish. Lubrication is provided from rocker gear spill and from cam lobe splash oil.

The pushrods, manufactured from medium carbon steel bar, have a circular foot forged on the lower end and a cup shape on the upper end. Both ends are induction hardened with the pushrod foot finally machine polished.

The mating end of each rocker adjusting screw is radiused to allow maximum surface contact with the pushrod cup during angular operation.

Cylinder heads

Manufactured from close grained, high duty cast iron, the two cylinder heads, each covering a bank of four cylinders, are machined across the upper and lower faces for a close tolerance fit between each rocker box assembly and cylinder-block top face respectively. Machined joint faces serve to accommodate the induction manifold on the inner and exhaust manifold on the outer side of each cylinder-head casting. Internal coolant passageways are cast around the valve guides and injector pockets.

Valve guides are cast in high quality nickel chrome alloy, ground to a final finish and inserted under pressure into the cylinder head casting.

Valve seat inserts are frozen into position against machined shoulders in the cylinder head casting.

The two inlet valves used for each cylinder are manufactured as steel forgings machined to close tolerances. The valve stems are chrome flashed. The two exhaust valves over each cylinder are manufactured in Nimonic material in two sections, friction welded near the valve heads, with the valve stems chrome flashed.

The valves are secured in a conventional collet, seat and spring arrangement, the exhaust valves being fitted with valve rotators in place of the upper spring

seats. Paired movement of the valves is controlled by a bridge piece, with the adjusting screw and locknut on the outer arm of the bridge. An induction hardened button is inset at the centre of the top face of each bridge piece, connecting with the rocker arm, pushrod and finally the tappet and camshaft.

The rocker arm assemblies for each bank of cylinders are mounted on a main rocker shaft housed in a cast aluminium rocker box. Each rocker box is located by two spring steel dowels protruding from the cylinder head, and secured by ten socket cap screws and eleven setbolts. The setbolts and screws are torque-tightened to a specific figure. An oil resistant gasket is fitted dry between the cylinder head and the rocker box.

Four injectors to each cylinder head are secured by setbolts on socket capscrews and finger clamps. Injector spill is discharged via banjo unions attached to the injector side connections protruding through the rocker box outer walls. Interconnecting pipework carries the spill fuel to the supply tank.

Top covers to each rocker box are manufactured in cast aluminium and are secured with ten setbolts, an oil resistant gasket being fitted between the two faces.

High pressure pipework connects the fuel injection pump with the injector inlet unions protruding through each rocker box cover.

Gear train

The wheelcase, mounted on the front of the engine, houses a train of helical gears with the main drive being provided by the crankshaft front gearing.

A small idler attached to the front main bearing transmits the drive to the oil pump gear. A large compounded idler attached to the crankcase forms the intermediate drive to the coolant pump gear and the fuel injection pump compounded gear, which in turn drives the two cam phasing gears.

On the automotive version of the CV8 engine, an idler driven by the fuel pump compounded gear provides the power take off for a compressor mounted on the back plate. Two auxiliary drive gears are carried in the 'B' bank side of the gear train, one over the cam phasing gear driven by the fuel pump gear and the other beneath the cam phasing gear, driven through an idler by the large compounded idler gear.

The timing gears, positioned across centres, use a machined spot on one tooth locating between two spots on the engaged gear.

The lubricating oil pump idler is secured to its axle

with a self locking nut. Other idler gears are secured with hexagon headed setbolts.

Flywheel

The flywheel and starter ring assembly is fitted to the rear end face of the crankshaft. Provision is made for the fitting of a transmission coupling to the flywheel, to suit individual engine applications.

The flywheel housing, bolted directly to the crankcase, supports a flange mounted Butec MS 1A or C.A.V. S 130L electric starter motor, on the lower 'B' bank side.

An Ingersoll Rand air starter is available, dependent upon the engine application.

A timing cover high on the 'A' bank side of the flywheel housing gives access to the flywheel timing marks and pointer.

Fuel system

The Bosch fuel injection pump, mounted on a platform in the centre of the crankcase 'V', is a conventional in-line unit feeding the eight injectors and is driven from the main gear train by a drive shaft with spring plate couplings.

The fuel injection pump camshaft hub is located by a key and secured with a spring washer and nut on the tapered shaft end. An adjustable yolk, bolted to the hub, carries one spring plate coupling assembly.

Viewed from the drive end, the pump camshaft rotates clockwise.

The firing order of the pump elements, numbered from the drive (engine wheelcase) end, is 1,4,3,5,8,7, 6,2 for engines fitted with the 'Paired Throw' crankshaft and 1,3,6,5,4,8,7,2 for engines fitted with the 'Cruciform' crankshaft. The pump firing order is at intervals of 45 degrees, with number one element at spill cut off point (B1 cylinder firing) in each case.

Static timing is stamped on the data plate affixed to the crankcase. High pressure fuel pipes connect each injector to the fuel injection pump in the following sequence viewed from the drive end:

B1, A1, B2, A2, B3, A3, B4, A4

The high pressure pipes are manufactured from 6 mm diameter steel pipe with a 2 mm bore. Zinc plated nuts and collars are incorporated at both ends of each pipe, with the cylinder number stamped on the side of the injector union nuts.

A mechanically operated feed pump delivers fuel from the supply tank(s), via low pressure pipework, to the

injection pump. A pump mounted relief valve allows excess fuel to be returned, with injector spill, back to the supply tank(s).

The low pressure pipework is manufactured in mild steel and incorporates standard low pressure joints of tubing nuts and sleeves.

Cooling system

The gear driven coolant pump consists of a conventional vaned impeller on a shaft, supported by twin ball races in a cast iron housing. The pump is designed to give a coolant flow of 227 litres/minute (50 imp. gallons/minute) at an engine speed of 1500 rpm.

A drilling in the bearing housing allows spill oil from the gear train to lubricate the ball-races, with the excess oil flowing through the front ball race back into the wheelcase. A lip type oil seal and a ceramic face coolant seal are fitted around the pump shaft between the bearing and coolant housings to prevent contamination. A telltale hole, drilled into the pump housing, indicates any leakage past either seal.

Coolant is delivered from the pump discharge directly to the oil-to-coolant heat exchanger situated on the 'A' bank side of the crankcase. From the heat exchanger the coolant is directed to the rear end of the 'A' bank coolant gallery cover where connecting pipework divides the coolant equally between the 'A' and 'B' bank galleries. The coolant then circulates around the cylinders and enters the cylinder heads where it circulates around the injector pockets and valve guides. Bobbin connections in the cylinder head inner walls then direct the flow into passageways in the induction manifolds. Outlets at the front end of each manifold allow the dual flows of coolant to merge at the thermostat housing where, if normal working temperature has not been achieved, the by-pass valve remains open for the coolant to return direct to the pump suction. At normal working temperatures the by-pass valve will be closed and the coolant will be directed through the radiator before passing to the coolant pump suction.

Under normal operating conditions the cooling system will be pressurised to 50 to 70 kN/sq. m. (7 to 10 lbf/sq. inch).

Lubrication system

A conventional wet-sump system is used on CV8 industrial engines. The cast aluminium sump, with an oil drainage well at one end, is reversible to suit the engine application.

Lubricating oil is drawn from the sump by a spur gear type pump and delivered under pressure to the two canister type filters. From the filters the oil passes through the single tube pack type oil-to-coolant heat exchanger, the base of which forms the oil filter header bracket.

The oil then enters a passageway near the front of the 'A' bank side of the crankcase and continues into a gallery running through the 'V'. A transfer casting, bolted to the rear face of the crankcase, allows the oil to enter the main gallery which is bored parallel to the first gallery.

From the main gallery, drillings at the front end direct the oil into auxiliary galleries running the length of the crankcase above the camshafts, whilst smaller drillings direct an oil supply to each main bearing housing.

Drillings from the auxiliary galleries direct oil to the camshafts, valve gear and cylinder liner outer walls.

A fitting with connecting pipework at the rear end of the main oil gallery delivers oil to the turbocharger bearings. Another fitting, adjacent to the oil feed connection, returns oil from the injection pump and governor and the turbocharger to the crankcase.

Drillings from the periphery of the front main bearing housing carry a supply of oil to the idler gear axles in the main gear train.

A hole drilled through the top face of each cylinder block into the relevant auxiliary gallery, allows oil to be delivered through drillings in the cylinder-heads into the central rocker pedestals. From the pedestals the oil is fed through hollow rocker shafts to each rocker arm bush. Drillings in each rocker arm direct a splash feed to the contact faces of the arm.

The pushrod feet and tappets are lubricated by the rocker arm drain oil running down each pushrod, and splash oil from the cam lobes.

Oil filler and dipstick

A steel pipe with an expanding type rubber plug is mounted on the sump for filling and topping up the lubrication system. A smaller bore tube also mounted on the sump houses the spring steel dipstick.

The oil filler pipe and dipstick tube may be mounted on either side of the engine to suit application.

Induction and exhaust systems

Cast iron manifolds direct the exhaust gases through the rotor section of the turbocharger where the waste

energy is used to drive the compressor wheel. This in turn draws air through the air cleaner and delivers it under pressure to the induction manifolds to be distributed to each cylinder as the inlet valves open.

Each exhaust manifold is made in two parts connected by a captive sleeve. The front section is a single bore pipe, the rear section is a double pipe to share the volume of gases leaving the cylinders. The exhaust from each bank of cylinders is led to the rear of the engine where a cross-connecting pipe forms a common discharge to the turbocharger rotor housing.

A bellows unit and flange adaptor bolted to the turbocharger outlet allow the fitting of exhaust pipework and silencers to suit the engine installation.

Where charge cooling is required, the air-to-air type of cooling is normally used. The compressor directs the air through pipework incorporated in the radiator to be fan cooled as is the engine coolant.

The cooled air is then delivered via large bore pipework to the induction manifolds.

Starter motor (Butec or C.A.V.)

A Butec MS1A starter, flange mounted on the 'B' bank side of the flywheel housing, is actuated through a solenoid switch bolted on the motor field ring. An over-running clutch, incorporated in the starter, prevents damage to the armature and starter ring under overload conditions.

The Lucas-C.A.V. S130L starter motor is a flange mounted model and operates through a solenoid switch mounted internally around the armature shaft. An overspeed ratchet device prevents damage to the armature should the starter ring drive the pinion when the engine starts up.

Both types of starter motor operate on a 24 volt circuit.

Alternator

A 30 amp Butec Type A13 or Type A3024 alternator, located on the 'B' bank side of the crankcase, is belt driven from the crankshaft front pulley. The alternator provides a 24 volt charging circuit for the starter batteries.

Engine protection

Pressure and temperature probe type switches are incorporated in the lubrication and cooling systems respectively. If the oil pressure drops below 152 kN/sq. m. (22 lbf/sq. inch) or coolant temperature exceeds 96 deg. C., the respective switch will actuate a shutdown solenoid to prevent serious engine damage.

The shutdown solenoid mounted in the crankcase 'V' is linked directly with the fuel injection pump STOP lever. The solenoid, used in the energised-to-run mode, overrides the governor control to stop the engine when the STOP button is pressed or when one of the engine protection switches detects oil pressure or coolant temperature beyond the permissible limits.

TECHNICAL DATA

TYPE.....Direct injection, liquid cooled, pressure charged
four stroke, compression ignition, with
charge cooling.

CONFIGURATIONEight cylinders in 90 deg. included angle 'V'.

BORE.....135 mm (5.315 inches)

STROKE152 mm (5.984 inches)

CUBIC CAPACITY
(Total swept volume)17.4 litres (1062 cu. inches)

COMPRESSION RATIO.....13.5 : 1

DIRECTION OF ROTATIONAnti-clockwise viewed on flywheel

CYLINDER FIRING ORDER
Paired Throw crankshaft A1, B1, A2, B2, B3, A4, B4, A3
Cruciform crankshaft A1, B1, B2, A3, B3, A2, A4, B4

ASPIRATIONPressure charged by a single, rear mounted
turbocharger

VALVE TAPPET CLEARANCES (Hot or cold)
Inlet0.2 mm (0.008 inch)
Exhaust.....0.5 mm (0.020 inch)

INJECTION TIMINGAs stamped on engine data plate

DRY WEIGHT OF BARE ENGINE (approximate)1202 kg (2,650 lb)

COOLING SYSTEM

APPROVED COOLANTSee leaflet TSD. 3085 in rear cover pocket

CAPACITY (approximate)91 litres (20 Imp. gallons)

TEMPERATURE (at sea level)
Normal running75 deg. C
Maximum intermittent95 deg. C

SYSTEM PRESSURE
(Normal working temperature) 50 to 70 kN/sq. m (7 to 10 lbf/sq. inch)

COOLANT FLOW RATE227 litres / minute (50 Imp. gallons/ minute)
at 1500 engine rpm

THERMOSTATWestern Thomson single element, wax
capsule type with radiator by-pass

RADIATORCov Rad or Marston
1.5 sq. m. (16 sq. ft.)

SYSTEM CLEANING COMPOUNDS
I.C.I. Limited* Lissapol 'N', 1% (10 cc/litre-45cc/Imp. gallon)
Lissapol 'NDB', 2% (20 cc/litre-90 cc/Imp. gallon)

* Lissapol 'N' is available from Rolls-Royce Motors Limited in 5.5 litre (1 Imp. gallon)
containers under part number OE 41334.

FUEL SYSTEM

APPROVED FUELS	See leaflet TSD. 3085 in rear cover pocket
TYPE	Pressurised supply to injection pump with through flow return to tank
INJECTION PUMP	Bosch S 3000, 8 element, in line unit
GOVERNOR	Bosch RQ (V) 2 speed, integral with injection pump Or Ambac Electronic
FEED PUMP	Bosch FP/KD Camshaft operated
FUEL FEED PRESSURE	140 to 210 kN/sq. m. (20 to 30 lbf/sq. inch)
FUEL INJECTORS	Axial feed, low spring type
INJECTOR NOZZLES	6 hole, 0.33 mm x 0.7 mm long, 150 deg. included angle spray, zero offset
INJECTION PRESSURE	240 bar (240 atmospheres)
INJECTION TIMING	As stamped on engine data plate
MAIN FUEL FILTER	Single, engine mounted, spin-on type expandable canister
PRIMARY FILTER	Single, Purolator PU 464, wire wound element or Harwood water separator/filter

LUBRICATION SYSTEM

APPROVED LUBRICANTS	See leaflet TSD. 3085 in rear cover pocket
TYPE	Wet sump
OIL CAPACITY	
Sump	36.3 litres (8 Imp. gallons) maximum 13.6 litres (3 Imp. gallons) minimum
System total	41 litres (9.4 Imp. gallons)
OIL PUMP	Conventional scavenge/pressure, gear type unit driven from main gear train
OIL PRESSURE	346 kN/sq. m. (50 lbf/sq. inch) under normal engine load conditions
	*170 kN/sq. m. (25 lbf/sq. inch). Minimum permissible at rated speed
	70 kN/sq. m. (10 lbf/sq. inch). Minimum permissible at idling speed. (Automotive)
OIL FLOW RATE	114 litres/minute (25 Imp. gallons/minute) at 80 deg. C. and 1500 engine rpm
PRESSURE RELIEF VALVE	
Type	Conventional spring and plunger (non- adjustable)
Opening pressure	415 kN/sq. m. (60 lbf/sq. inch)

OIL FILTERS Two spin-on type expendable canisters
(engine mounted)
MAXIMUM OIL TEMPERATURE 120 deg. C.
OIL-TO-COOLANT HEAT EXCHANGER Serck, shell and tube, baffled and finned

* Important for the protection of turbocharger bearings

INDUCTION SYSTEM

AIR CLEANERS Donaldson Cyclopac FHG 12 (2)
TURBOCHARGER Holset 4LGK

ELECTRICAL EQUIPMENT

ALTERNATOR..... Butec 24 volt 30 amp, belt driven
STARTER MOTOR Butec type MS1A or Lucas C.A.V. S130L
STOP CONTROL Lucas C.A.V. solenoid operated. Type 368/9B
WARNING AND SHUTDOWN SWITCHES Teddington temperature switch.
TYPE DCA/AB/096. 96 deg. C. setting.
Teddington pressure switch. Type DCA/BC/152.
152 kN/sq. m. (22 lbf/sq. inch) setting.

**LUBRICANTS AND FLUIDS APPROVED FOR USE
DURING SERVICING AND OVERHAUL**

(Equivalents of alternative manufacture are acceptable)

	Manufacturer	Brand or specification
ALTERNATOR		
Diode cleaning fluid	Applied Chemicals Ltd	Fluid grade 8-23
Diode grease	—	Silicon MS200, MS4, MS5
COOLING SYSTEM		
Hose and 'O' ring lubricant	—	Castor oil
EXHAUST SYSTEM		
Screw thread anti-seize grease	Rocol Ltd Slip Group	Rocol J166 Copaslip
INDUCTION SYSTEM		
Emulsifying solvent	Morris's Shrewsbury	Pavan
JOINTS		
Jointing compound	Wellworthy Ltd	Wellseal
Sealant and thread locking where specified	Douglas Kane Sealants	Loctite 601, 542, Studlock 270, green retaining compound 290.

STARTER MOTOR

Commutator cleaning fluid	I.C.I. Limited	Genklene 'N'
	Applied Chemicals Limited	Fluid grade 8-23
Lubricator wick oil (Butec)	Various	Mineral oil SAE 5W/20
Lubricator wick oil (C.A.V.)	Shell	Tellus T27 oil
Armature shaft bush (C.A.V.)		Turbo 41 oil
Grease, where specified (C.A.V.)		Aero Shell 16 grease
Insulating adhesive (C.A.V.)	Bostik	Clear adhesive 1437

Detailed information, for the products listed below, will be found on the Manufacturers data sheets.

DYE PENETRANT

Ardrox 996: Ardrox Limited, Brentford, Middlesex.

GENERAL CLEANING AND INHIBITION

Ardrox 667: Ardrox Limited, Brentford, Middlesex.

Maxan 774: Henkel Chemicals Limited, Edgware Road, London.

These products are methylene chloride based and are safe to use on most metals for the removal of carbon build up and for paint stripping. They are harmful to rubber and most plastic materials.

Method of use

The components to be cleaned must be immersed in the cleaning fluid long enough to produce the required standard of cleanliness. After cleaning, the components must be thoroughly rinsed in clean water. In use, maintain a water seal of at least 76 mm (3 inches) above the cleaning fluid to prevent evaporation and the escape of toxic fumes.

Goggles and protective clothing must be worn at all times when using these fluids and the container must be in a well ventilated area.

Do NOT smoke in the vicinity of the cleaning tank.

Duroclean 150 powder: Diversey Limited, Northampton.

This product is an alkali based degreasing compound and is safe to use on brass, copper and ferrous metals. It must not be used on aluminium, lead, tin and zinc.

Method of use

The components to be degreased must be immersed in a solution of the compound, heated to 65 deg. C. (150 deg. F.), until all contamination has been removed. It is recommended that Duraclean 150 should be used at the top concentration of 50 grammes/litre of water. Rinse off the concentrate with clean water; if desired, a suitable inhibitor may be added to the final rinse.

Goggles and protective clothing must be worn when using this product.

Crodafluid CR2: Croda Chemicals Limited, Goole, Yorkshire.

This product is an inhibited, acid based solution for the derusting of ferrous components.

Method of use

Croda fluid CR2 must be held in a tank lined with, or made from, an acid resistant material. The components to be treated must be degreased before being immersed in the derusting solution. For medium to heavy deposits of rust, the solution may be heated to 70 deg. C. (158 deg. F.). Inspect the components occasionally to check the derusting progress. Light rust may be removed in a few minutes. Finally, wash the components thoroughly in clean water.

Goggles and protective clothing must be worn at all times during the above process.

Diverspray 30: Diversey Limited, Northampton.

This product is a mild, alkali based cleaning compound containing rust inhibitors, and may be sprayed over the components to be cleaned or held in a tank, for immersion of the components, with agitation. Diverspray 30 may be added to rinse water of components which require inhibiting after other treatments, e.g. derusting.

TORQUE LOADINGS

Note: The following torque loadings apply to clean threads in oil-wetted condition, unless the use of thread locking compound is advocated.

It must NOT be assumed that application of the specified torque is, in itself, sufficient to ensure that the components concerned are adequately secured together. The recommended method of assembling and, where applicable, tightening sequence must also be observed. This information is given in the relevant Section of this Manual.

Where the bolt or nut is locked by a tabwasher, lockplate or splitpin the specified torque may be exceeded, if necessary, by the MINIMUM amount required to reach a locking position.

	Nm	lbf. ft.
ALTERNATOR		
Pulley nut (Full nut - Nyloc)	95	70
(Thin nut)	50	37
AUXILIARY DRIVE SHAFT		
Hub nut (18 mm diam. thread)	200	148
(22 mm diam. thread)	300	220
CAMSHAFTS		
Drive gear setbolts (with Studlock 270)	40	30
Thrust plate countersunk screws	70	50
CONNECTING RODS		
Big end bearing bolts	60	44
CRANKSHAFT		
Pulley setbolts	95	70
Flywheel setscrews	315	232
CYLINDER HEADS		
Securing setbolts - Long	240	175
Securing setbolts - Short	175	130
	(plus further 60 deg.)	
COOLANT PUMP		
Drive gear nut	88	65
Bearing locknut	100	74
EXHAUST MANIFOLDS		
Securing setbolts	47	35
FAN ADAPTOR		
Bearing locknut	135	100
FLYWHEEL HOUSING		
Bolts to crankcase	95	70

	Nm	lbf. ft.
FUEL INJECTION PUMP		
Camshaft hub nut	149	110
Mounting setbolts	41	30
Adjustable coupling setbolts	41	30
Delivery valve connectors	80	60
Delivery valve assembly nuts	40	30
Spring plate coupling bolts	120	88
FUEL INJECTORS		
Clamp setbolts	40	30
or Socket capscrews	60	44
Nozzle capnut	81	60
Spill connections	27	20
GEAR TRAIN		
Compound gear setbolts (Using Studlock 270)	40	30
Auxiliary drive gear setbolts (Using Studlock 270)	30	22
Main idler gear axle setbolts	71	52
LUBRICATING OIL PUMP		
Oil pump idler gear axle nut (Nylloc)	80	60
Gear retaining nut	120	88
Casing setbolts	21	15
MAIN BEARING CAPS		
Securing setbolts	488	360
Lateral setbolts	177	130
ROCKER BOXES		
Securing setbolts	41	30
Socket capscrews	35	26
Rocker cover setbolts	21	15
Bridge piece adjusting screw locknut	40	30
Tappet adjusting screw locknut	40	30
SUMP		
Securing setbolts	55	40
Insert for drain plug (Using Loctite 542)	305-340	225-250
Drain plug	110-115	80-85
TURBOCHARGERS		
'V' band clamps: Multi segment	13.5	10
Single segment	18	13
Turbine housing	13.5	10
<i>Note: Tighten multi-segment to 13.5 Nm plus a further 120 deg. Slacken and retorque to 13.5 Nm.</i>		
Other applications: Captive 'T' bolt	17	12.5
Quick release	9	7
WHEELCASE AND BACKPLATE		
Bolts to crankcase	95	70

SECTION 2 — DISMANTLING THE ENGINE

Before dismantling, clean the engine thoroughly and ensure that the cooling and lubricating oil systems are drained completely. Coolant drain cocks are fitted to each side of the cylinder block and a drain plug is fitted beneath the lower end of the coolant pump/radiator pipe.

Most of the lubricating oil can be drained via the two sump plugs. Oil trapped in the heat exchanger may be drained by removing the oil filter canisters*.

Where dismantling involves the removal of proprietary items (e.g. turbocharger), or a sub-assembly, instructions for reducing these units to their component parts are given in the appropriate sections.

To facilitate refitting of the components, the smaller items (e.g. fuel injection pipes, clips, brackets etc.) should be labelled and stored in containers with associated engine parts.

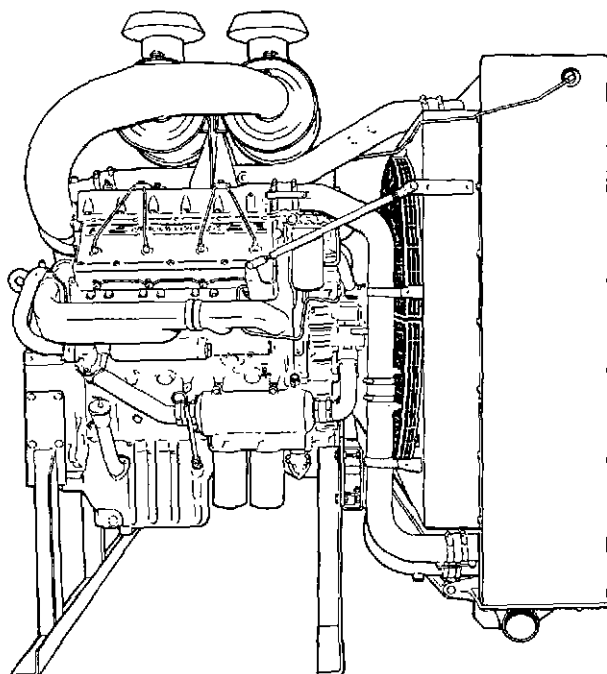

Fig. 1 Engine/radiator assembly on transportation stands.

Prior to the removal of the radiator, the engine may be mounted on simple support stands, as used for transportation (see fig. 1). Once the radiator has been removed, the engine will stand on its sump with appropriate packing beneath the front end.

The following sequence is given as a guide for the convenience of Operators.

Items in this Section marked will necessitate the use of Special Tools, some of which are illustrated in SECTION 3—ASSEMBLING THE ENGINE.*

DISMANTLING SEQUENCE

1. Remove the air ducting between the air cleaners, turbocharger, radiator and induction manifolds.
 2. Remove the air cleaners and support brackets.
 3. Remove the coolant pipework between the engine and radiator.
 4. Remove the crankcase breather pipe.
 5. Remove the fan guard.
 6. Remove the radiator, stay rods, mounting beam and mounting brackets.
 7. Remove the fan.
 8. Remove the dipstick tube, oil filler pipe and coolant drain cocks.
 9. Remove the oil-to-coolant heat exchanger and associated pipework.
 10. Remove the alternator and mounting bracket.
- Fit the front and rear engine mounting brackets and secure the engine in the turnover build stand then proceed.
11. Remove the starter motor.
 12. Remove the fuel filter, header bracket and associated pipework.
 13. Remove the exhaust elbow and bellows unit.

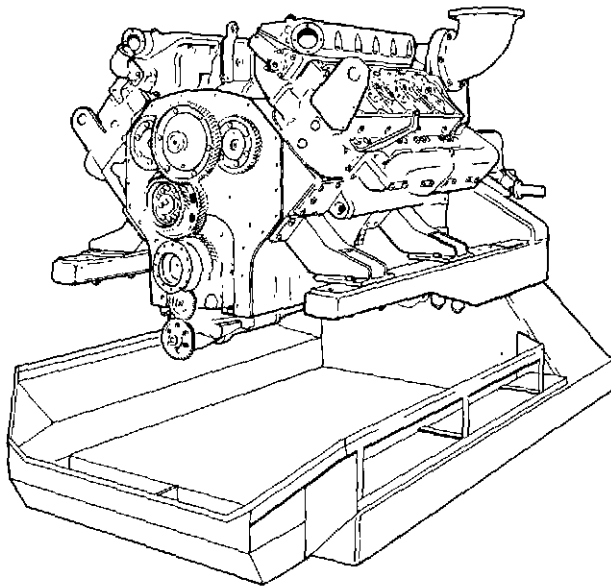

Fig. 2 Engine in Turnover Build Stand VP.5908.

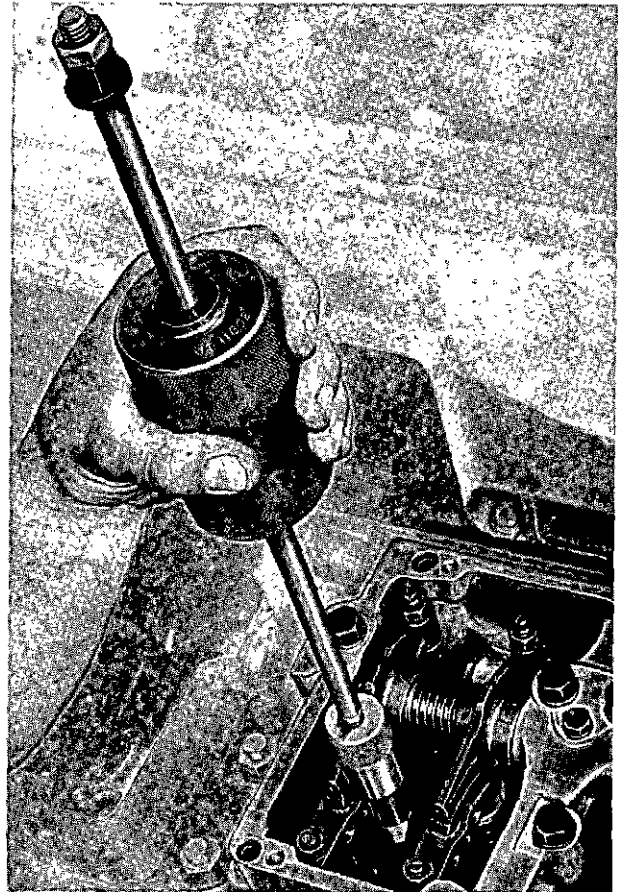

Fig. 3 Removing sticking injector.

14. Remove the turbocharger, oil pipework and exhaust manifolds.
15. Remove the coolant rail.
16. Remove the front engine mounting.
17. Remove the Engine Service Counter.
18. Release the jockey pulley and remove the fan belts.
19. Remove the crankshaft pulley and counter balance.
20. Remove the fan pulley and jockey pulley.
21. Remove the rocker covers.
- *22. Remove the fuel injector clamps and withdraw the injectors. A sticking injector may be freed using the Inertia Extractor, VT. 11692 and Adaptor VT. 17973. Care must be taken to avoid slackening the copper injector sleeve in its housing when using the extractor.
23. Remove the rocker boxes and withdraw the pushrods.
- *24. Disconnect the auxiliary drive coupling and remove the fuel injection pump and shut down solenoid.
25. Remove the fuel feed pump.
26. Remove the coolant pump and associated pipework.
27. Remove the thermostat housing.
28. Remove the induction manifolds and coolant transfer bobbins.
29. Remove the crankcase breather adaptor.
30. Remove the fan adaptor.
- *31. Remove the wheelcase.
- *32. Remove the flywheel and flywheel housing.
33. Remove the turbocharger mounting duct and heat shield/lifting eye.
- *34. Tilt the engine and remove each cylinder head and oil transfer bobbins.
- *35. Withdraw the tappets and secure the cylinder liners with the retaining bars.

- *36. Remove the auxiliary drive coupling yoke, then remove the auxiliary drive oil seal housing.
- 37. Remove the idler gears.
- 38. Remove the camshaft thrust plates and withdraw the camshafts.
- *39. Remove the wheelcase back plate.

Turn the engine over until the sump is uppermost.

- 40. Remove the sump.
- 41. Remove the oil pump pipework.
- 42. Remove the oil pump.
- 43. Remove the baffle plate.
- *44. Slacken all the big end bearing bolts and tilt the engine to the required angle; withdraw each piston/connecting rod assembly, using the Guide Pin, VT 14048. Turn the engine until the sump face is again uppermost.

- *45. Remove all main bearing caps with bearing shells, and thrust washer bottom halves.
- *46. Lift out the crankshaft and bearing shells, and thrust washer top halves.
- 47. Remove the piston oil jets.
- *Turn the crankcase upright and remove from the build stand.
- 48. Remove the mounting brackets.
- 49. Remove the oil transfer housing from rear face of crankcase.
- 50. Remove the coolant gallery covers.
- 51. Remove the retaining bars and withdraw the cylinder liners.
- *52. Remove any suspect cup plugs.

SPECIAL TOOLS

Part Number	Description
VP 5015	Lifting beam, complete engine.
VP 6202	Lifting beam, engine/radiator assembly.
VP 5007	Lifting bracket, cylinder head.
VP 5008	Lifting bar, flywheel.
VP 5014	Lifting plate, flywheel housing.
VP 5641 (2)	Mounting bracket, engine to build stand.
VP 5642 (2)	Mounting bracket, engine to build stand.
VP 5908	Build stand engine.
VP 6815	Lifting plate, crankcase.
VP 7621/1	Lifting bracket, crankshaft (CV 2457).
VP 7621/2	Lifting bracket, crankshaft (CV 7693).
VT 14040 (2)	Guide studs, flywheel to crankshaft.
VT 11496 (2)	Guide studs, main bearing caps.
VT 11671	Inertia extractor, main bearing caps.
VT 11692	Inertia extractor, fuel injectors.
VT 17973	Adaptor, inertia extractor (VT 11692).
VT 14048	Guide pin, connecting rod big end.
VT 12341	Extractor, auxiliary drive yoke.
VT 12918	Wrench, fuel filter canisters.
VT 17416 (2)	Retaining bar, cylinder liners.
VT 17844 (2)	Guide studs, flywheel housing.
VT 17845 (2)	Guide studs, wheelcase.
VT 17877	Barring adaptor, crankshaft.
VT 18038	Wrench, oil filter canisters.

Cup plug servicing kits are available in a range of sizes to suit the bore of the component which houses a particular cup plug. Each kit consists of a tap, an extractor nut and an insertion tool. The following is a list of kits available and the correspondence cup plug sizes:

Kit Number	Cup Plug Size
VT 12859	12 mm
VT 12862	16 mm
VT 12865	20 mm
VT 12868	22 mm
VT 12874	25 mm
VT 12877	32 mm
VT 12883	40 mm
VT 12886	45 mm
VT 12889	50 mm
VT 12892	71.5 mm

SECTION 3 — ASSEMBLING THE ENGINE

Components referred to in this Section include sub-assemblies which have been overhauled as described under their respective headings elsewhere in this Manual.

Instructions concerning assembly procedure, which are given in the General Information section, will do much to ensure long and trouble-free service from the engine if they are carefully followed during engine build.

ASSEMBLY SEQUENCE

1. Fit two Mounting Brackets, VP 5641, and two Mounting Brackets, VP 5642, to the sides of the crankcase and secure each with four slave setbolts.
2. Using five slave setbolts, secure the Lifting Plate, VP 6815, to the fuel injection pump location in the crankcase 'V'. Lift the crankcase into the Turnover Build Stand, VP 5908, with the front (free) end facing outwards. Secure the assembly with eight bolts and nuts and remove the lifting plate.

Crankshaft and main bearings

3. Turn the crankcase until the sump joint face is uppermost and position the upper halves of the main bearing shells. Smear the bearing surfaces liberally with clean engine lubricating oil and using the appropriate lifting bracket, (see the Special Tools list at the end of the Section), lower the prepared crankshaft assembly into position. Ensure that the bearing shells are not dislodged during this operation.
4. Smear the upper halves of the thrust washers with clean engine lubricating oil and feed them into the recesses at each side of the centre main bearing. Ensure that the bronze faces of the washers are toward the crankshaft webs.
5. Fit the lower halves of the main bearing shells into the bearing caps and smear each shell liberally with clean engine lubricating oil.

6. Apply a light smear of grease to the recesses on each side of the centre main bearing cap, fit the lower halves of the thrust washers into their recesses with the bronze faces outwards then fit the bearing cap assembly into the crankcase using Guide Studs, VT 11495. If the cap is a tight fit in its housing, use a soft-faced mallet to tap it into position. Remove the guide studs, fit the securing setbolts, (see Item 8) and align the cap with the crankcase housing. Tighten the setbolts securely and check the crankshaft for axial movement. If it is found that the crankshaft is difficult to move, check that the thrust washers are not being bowed by pressure on the butts. If this is the case, the bowing may be cured by removing the bearing cap and filing the butts of the thrust washers. Refit the thrust washers and bearing cap, and re-check the crankshaft movement.

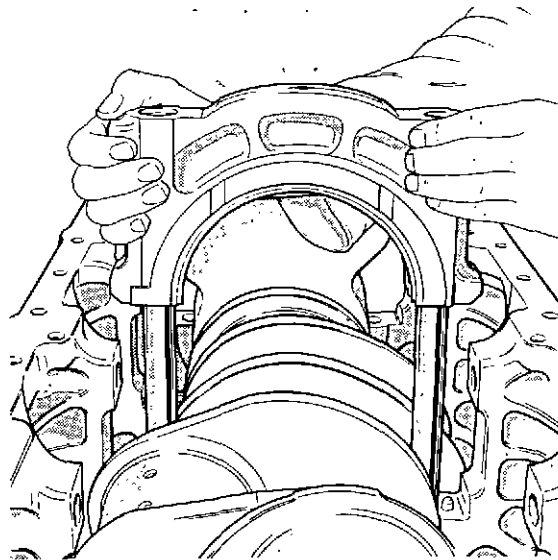

Fig. 1 Fitting centre main bearing cap.

7. Fit the other four main bearing cap assemblies into the crankcase ensuring that the correlation numbers on each cap coincide with the numbers stamped in the crankcase.

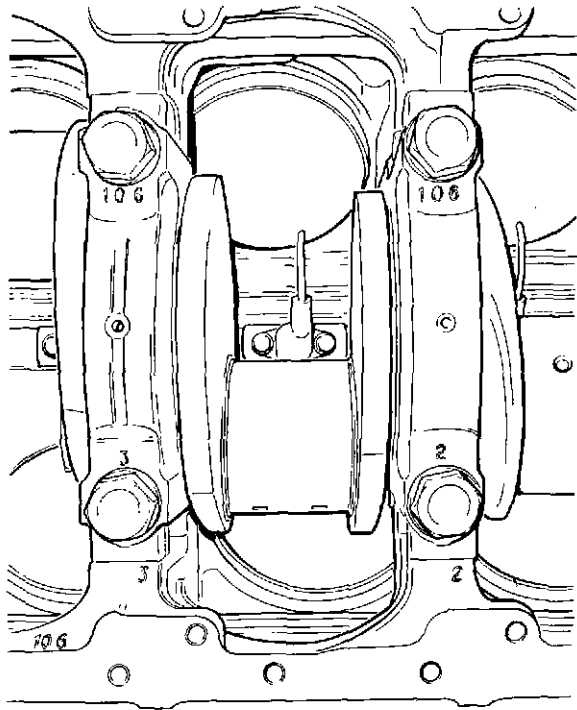

Fig. 2 Main bearing correlation numbers.

8. Oil-wet the underside of the heads and the threads of the main bearing cap and lateral setbolts and run each bolt in finger tight.
Note: Plain washers must be fitted beneath the head of each lateral set bolt.
9. Ensure that each main bearing cap machined side face is flush with the corresponding face of the crankcase then tighten the main setbolts to a torque loading of 488 Nm (360 lbf. ft.) in the sequence given in Figure 3.
Note: As each main bearing cap is secured, check the crankshaft for freedom of rotation before tightening the setbolts of the next bearing cap in the sequence.
10. Tighten the lateral setbolts in alphabetical order as shown, to a torque loading of 177 Nm (130 lbf. ft.).
11. Set up a D.T.I. gauge as shown and measure the crankshaft end float by levering the shaft backwards and forwards with a small crowbar or large screwdriver. End float should be between 0.10 mm and 0.30 mm (0.004 and 0.012 inch).

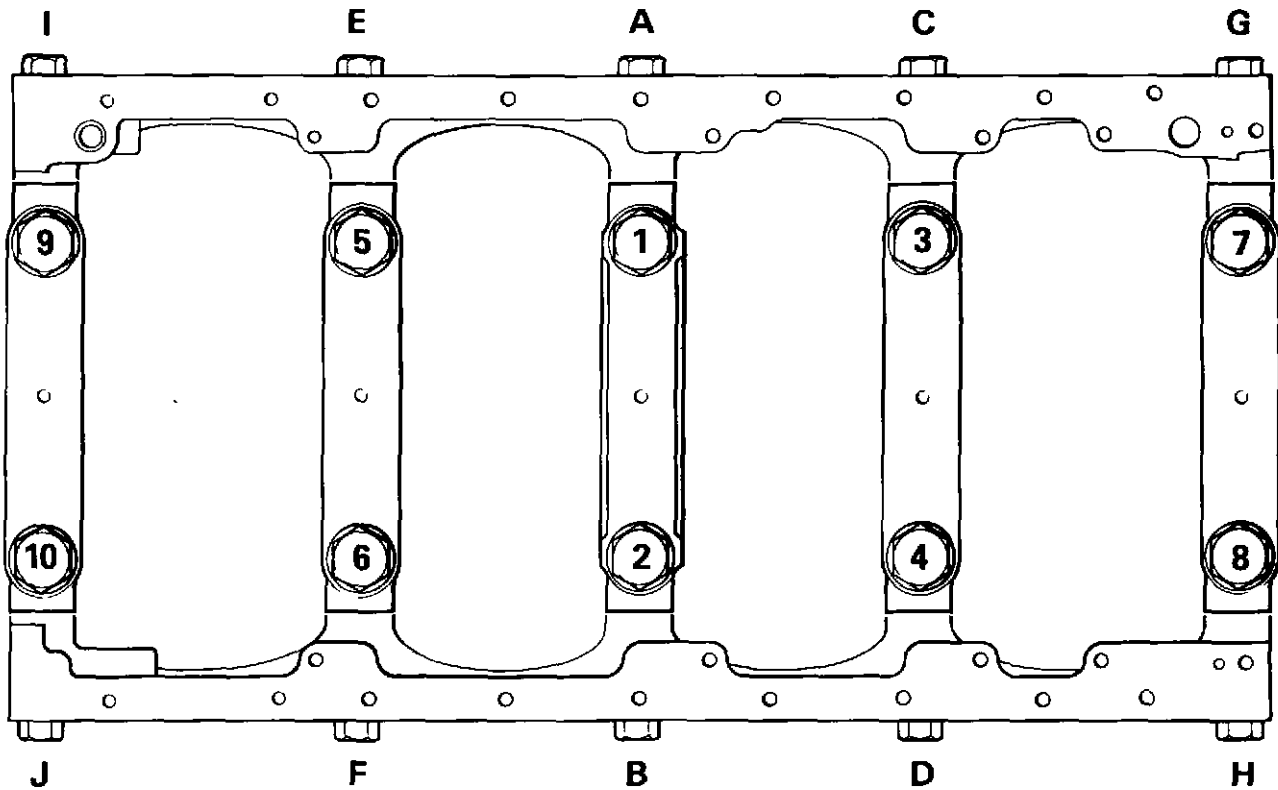

Fig. 3 Main bearing cap bolt tightening sequence.

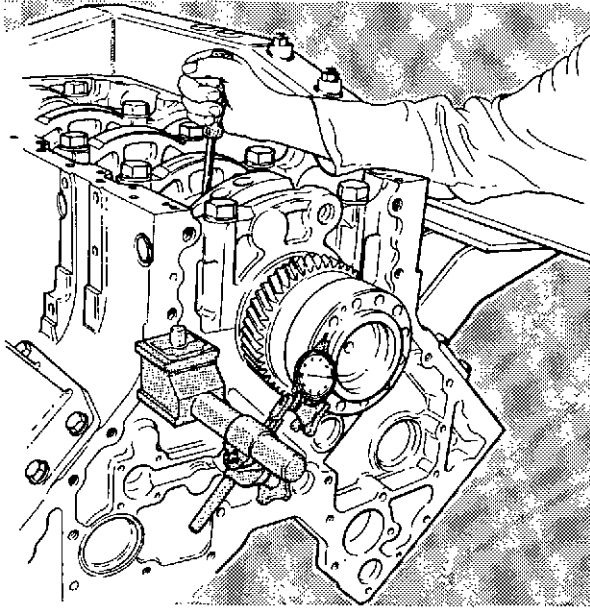

Fig. 4 Measuring crankshaft end float.

Rear oil seal

12. Place the baseplate of the Seal Insertion Tool, VT 17880, on the table of a hand operated press and position the rear oil seal housing on the locating pins. Press the oil seal fully into its housing using the pressure ring. Fit the housing to the rear end face of the crankcase with a jointing gasket and nine setbolts and spring washers. Ensure that the crankcase sump face and lower face of the oil seal housing are correctly aligned before tightening the setbolts. Slip an 'O' ring seal into the machined groove around the periphery of the housing.

Cylinder liners

13. Check the landings of each cylinder liner. Lap in if necessary. (See Section 4—Crankcase and Cylinder Liners).
14. Apply a light coating of 'Wellseal' jointing compound to the shoulder of each liner and insert it into its respective bore. Fit the liner Retaining Bars, VT 17416.
15. Fit the crankshaft Barring Adaptor VT 17877, to the front end of the crankshaft.
16. Turn the crankcase until the 'A' bank is horizontal and rotate the crankshaft until 'A1' crankpin is at B.D.C.

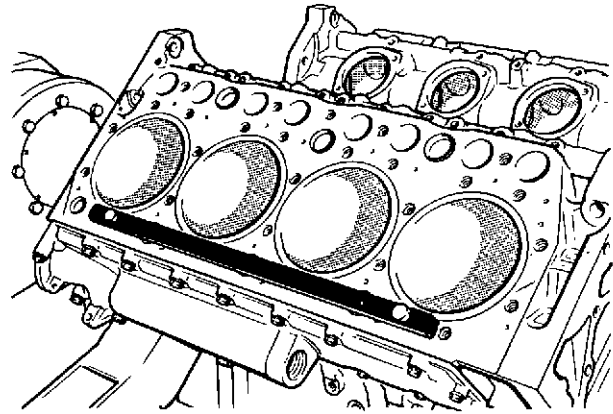

Fig. 5 Liner retaining bar.

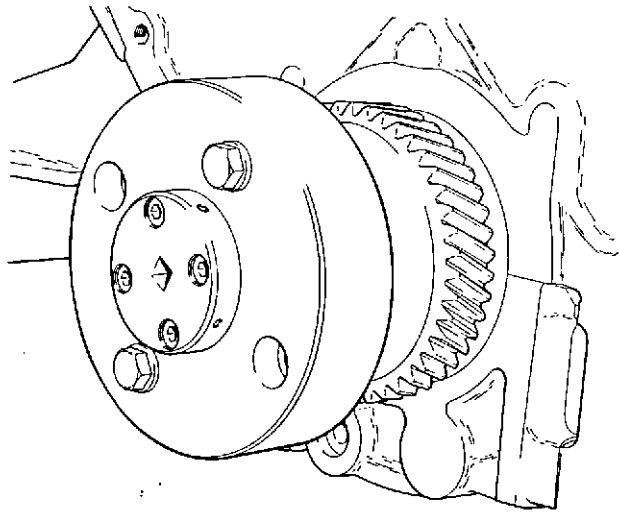

Fig. 6 Crankshaft barring adaptor.

Pistons and connecting rods

17. Screw the Guide Pin, VT 14048, on to a bolt in the 'A1' piston/connecting rod assembly.
18. Ensure that the piston ring gaps are correctly 'staggered', lubricate the piston liberally with clean engine oil and push the piston/connecting rod assembly into the 'A1' cylinder bore using the Piston Ring Sleeve, VT 10714.
19. Oil the big-end bearing and carefully guide the big end on to the crankpin with the chamfered bore of the connecting rod facing the adjacent crank web.

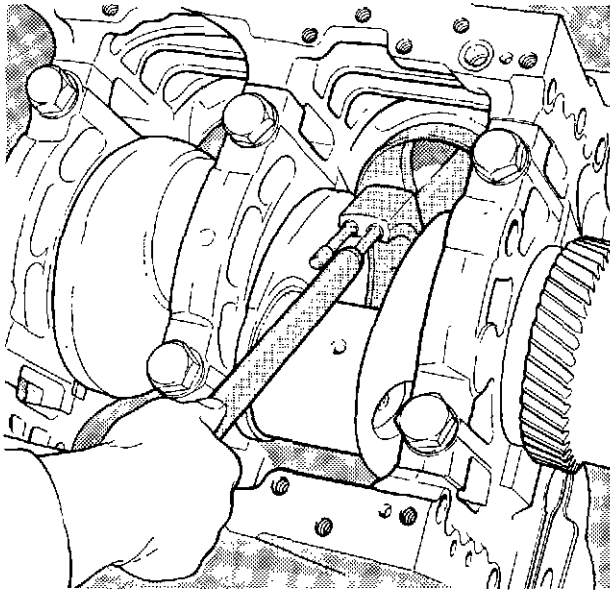

Fig. 7 Connecting rod guide pin.

20. Remove the guide pin, liberally oil the crankpin and fit the bearing cap/shell assembly on the big end securing bolts.
21. Lightly oil the bolt threads before fitting the nuts. Nip each nut before proceeding to the next unit.
22. When all 'A' bank pistons are fitted, check that the oil jets locate correctly in the piston skirt cut-outs as the crankshaft is rotated.
23. Turn the crankcase until 'B' bank is horizontal and rotate the crankshaft until 'B1' crankpin is at B.D.C.
24. Carry out the piston fitting procedure for all 'B' bank cylinders and check oil jet locations.
25. Turn the crankcase so that the sump joint face is uppermost and tighten the big-end bolts in a diagonal pattern to a torque loading of 60 Nm. (42 lbf. ft.). Continually check the crankshaft for freedom of rotation as each unit is tightened.

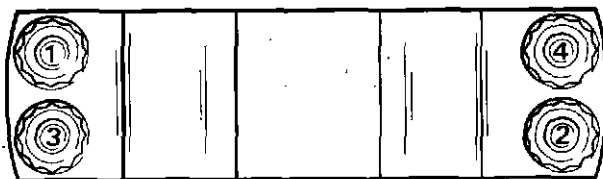

Fig. 8 Big end bolt tightening sequence.

26. Set up a D.T.I. gauge as shown and check the end float of the big ends. The permissible end float is between 0.2 mm and 0.4 mm (0.008 inch and 0.016 inch).

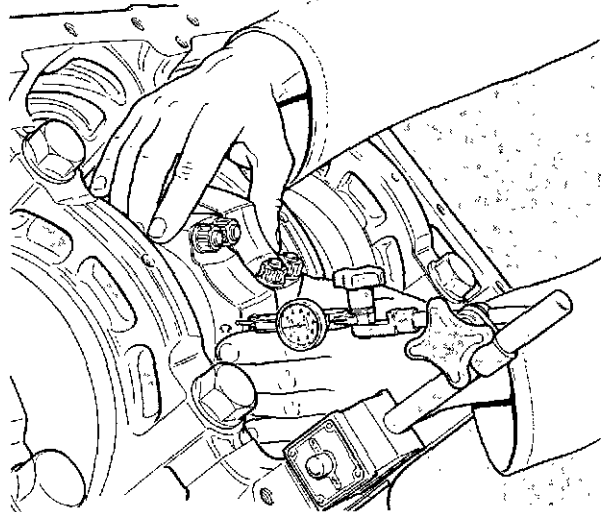

Fig. 9 Checking connecting rod big end float.

27. Rotate the engine until the 'A' bank flame face is horizontal and check the depth of each piston crown at T.D.C. below the cylinder block flame face, using Height Gauge, VT 10715. Permissible clearances are 0.31 mm to 0.38 mm (0.012 inch to 1.015 inch).

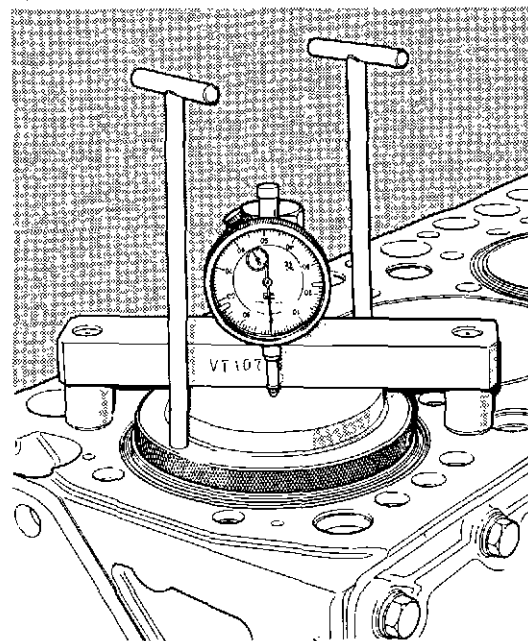

Fig. 10 Checking piston height.

28. Rotate the engine until the 'B' bank flame face is horizontal and check the 'B' bank piston/flame face clearances.

Wheelcase backplate

29. Apply a thin coating of 'Wellseal' to the backplate joint face, position the gasket on the backplate and apply a further coating to the outer face of the gasket.
30. Fit two Guide Studs, VT 17845, in the crankcase/wheelcase bolt holes and position the backplate. Tap in the two locating dowels and secure the backplate with six setbolts and spring washers. Remove the guide studs.

Camshafts

31. Fit the Lead-in Mandrel, VT 17842, to the end of the 'A' bank camshaft, liberally oil the camshaft bushes and feed in the camshaft. Before the camshaft is completely home, engage the thrust plate on the camshaft collar, coat the underside of the counter-sunk screw heads with anti-seize compound and secure the thrust plate to the crankcase. Torque tighten the screws to 70 Nm (50 lbf. ft.).
32. Transfer the lead-in mandrel to the 'B' bank camshaft and fit the camshaft and thrust plate. Remove the lead-in mandrel.
33. Set up a D.T.I. gauge and check the end float of each camshaft. Permissible movement is 0.01 to 0.55 mm (0.004 to 0.022 inch). After checking the end float, fit the two large steel cup plugs into the crankcase camshaft bores, using Insertion Tool, VT 10708.

Note: Coat the edge of each cup plug with Loctite 542 and insert the plugs so that the lip is *just* below the end face of the crankcase.

Gear train

34. Fit the gear rings to each camshaft flange, tap in the locating dowels and, using Studlock 270 on the threads secure each gear ring with six setbolts and plain washers. Torque tighten the securing setbolts to 40 Nm (30 lbf. ft.).
35. Using Studlock 270 on the threads, assemble the large and small idler gears with 12 setbolts

and 1 plain washer. Tap in the locating dowel and torque tighten the setbolts to 40 Nm (30 lbf. ft.), then fit the assembly to the crankcase with two thrust washers, thrust plate and axle, and secure with two setbolts and lockplate. Ensure that the large gear timing marks are correctly aligned with the crankshaft timing mark before torque tightening the setbolts to 71 Nm (52 lbf. ft.). Tab up the lockplate.

36. Fit the oil pump idler gear on to its axle, with the boss extension away from the axle flange. Push the axle securing bolt through the drilling in the front main bearing cap, from the inner side. Fit the axle over the bolt with the idler gear in mesh with the crankshaft gear and run the self-locking nut up to the axle flange. Torque tighten the nut to 80 Nm (60 lbf. ft.).
37. Check the backlash between the gears as follows:

Set up a magnetic based D.T.I. gauge on the backplate, so that the gauge lever rests upon the side of one of the teeth on the oil pump idler gear. Rotate the idler gear by hand as far as possible in each direction and check the deflection of the D.T.I. needle. The total movement should be between 0.100 and 0.235 mm (0.004 and 0.009 inch).

Next, set up the D.T.I. gauge to check the backlash of the main idler gear. The deflection should be between 0.100 and 0.239 mm (0.004 and 0.0095 inch).

Auxiliary drive assembly

38. Remove the oil seal housing and woodruff key from the auxiliary drive assembly, preparatory to fitting to the backplate.
39. Turn both camshafts until the timing marks on the gears face in towards the centre of the engine.
40. Fit the auxiliary drive assembly to the backplate with the outer gear timing mark in mesh with the timing marks on the small idler gear and ensuring that the camshaft timing marks are in mesh with the timing marks on the auxiliary drive assembly inner gear. The two 'sight holes' in the outer gear facilitate the lining up of the latter timing marks.

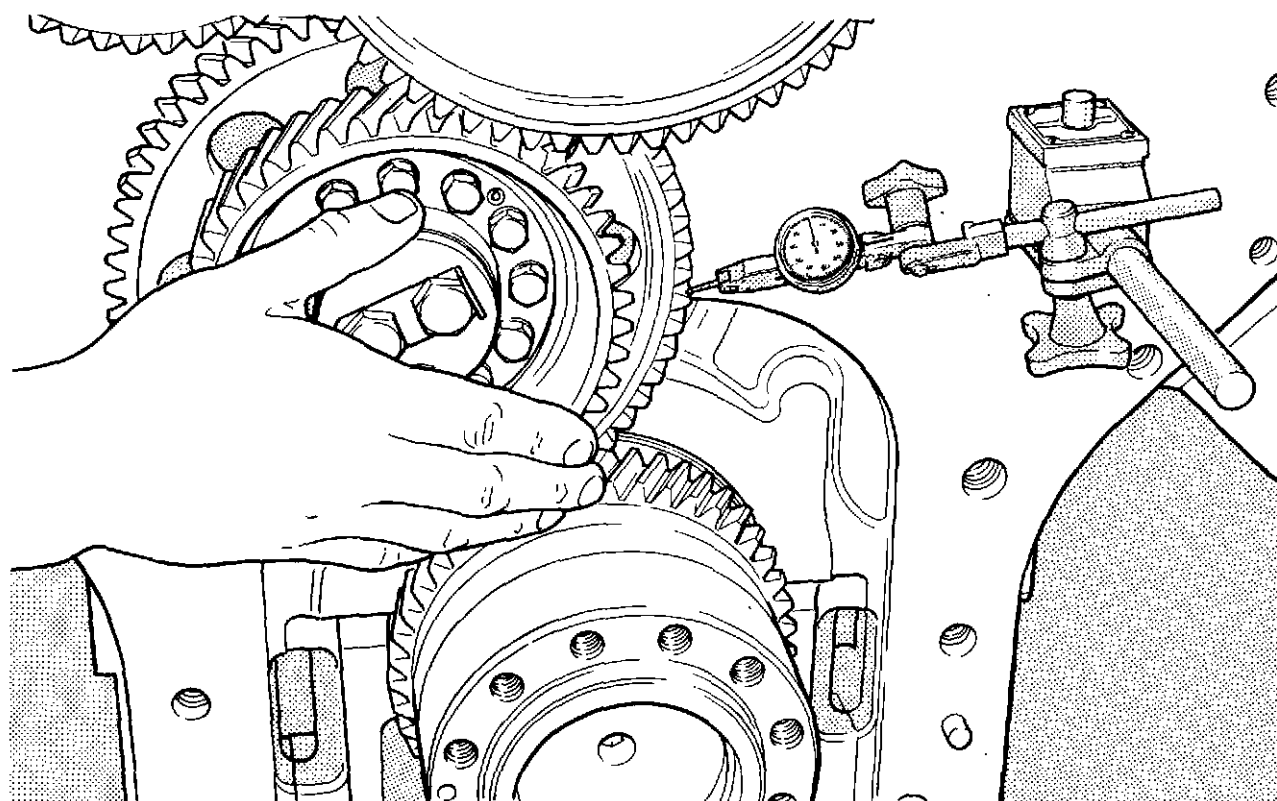

Fig. 11 Checking main idler gear backlash.

Fit the housing of the Alignment Tool, VT 17974, over the studs on the engine side of back plate and secure with the oil seal housing nuts. Enter the sleeve section of the tool into the housing and screw up the sleeve, hand tight, on the auxiliary drive shaft thread. This will hold the gear steady to enable correct backlash readings to be taken between the auxiliary drive gear and the meshing gears, i.e. camshafts and main idler.

Note: When measuring backlash, always ensure that one of the gears is held stationary, otherwise false readings will be obtained.

41. Check the end float of the idler gears as follows:

Set up the D.T.I. gauge as Item 37 but let the gauge lever rest on the outer face of the gear to be checked; note the total axial movement of the gear. The end float for the main idler gear

must be between 0.100 and 0.425 mm (0.004 and 0.017 inch). The end float for the oil pump idler gear must be between 0.150 and 0.300 mm (0.006 and 0.012 inch).

Cylinder heads

42. Turn the engine so that the 'A' bank flame face is horizontal and remove the cylinder liner retaining bars.
43. Liberally oil the tappet bores and fit the tappets.
44. Fit the two cylinder head locating dowels and the oil transfer bobbin, complete with sealing ring, into the cylinder block flame face and position the new cylinder head gasket.
45. Screw two Guide Studs, VT 17843, into the cylinder head bolt holes and carefully lower the cylinder head into position, using the Lifting Bracket, VP 5007.

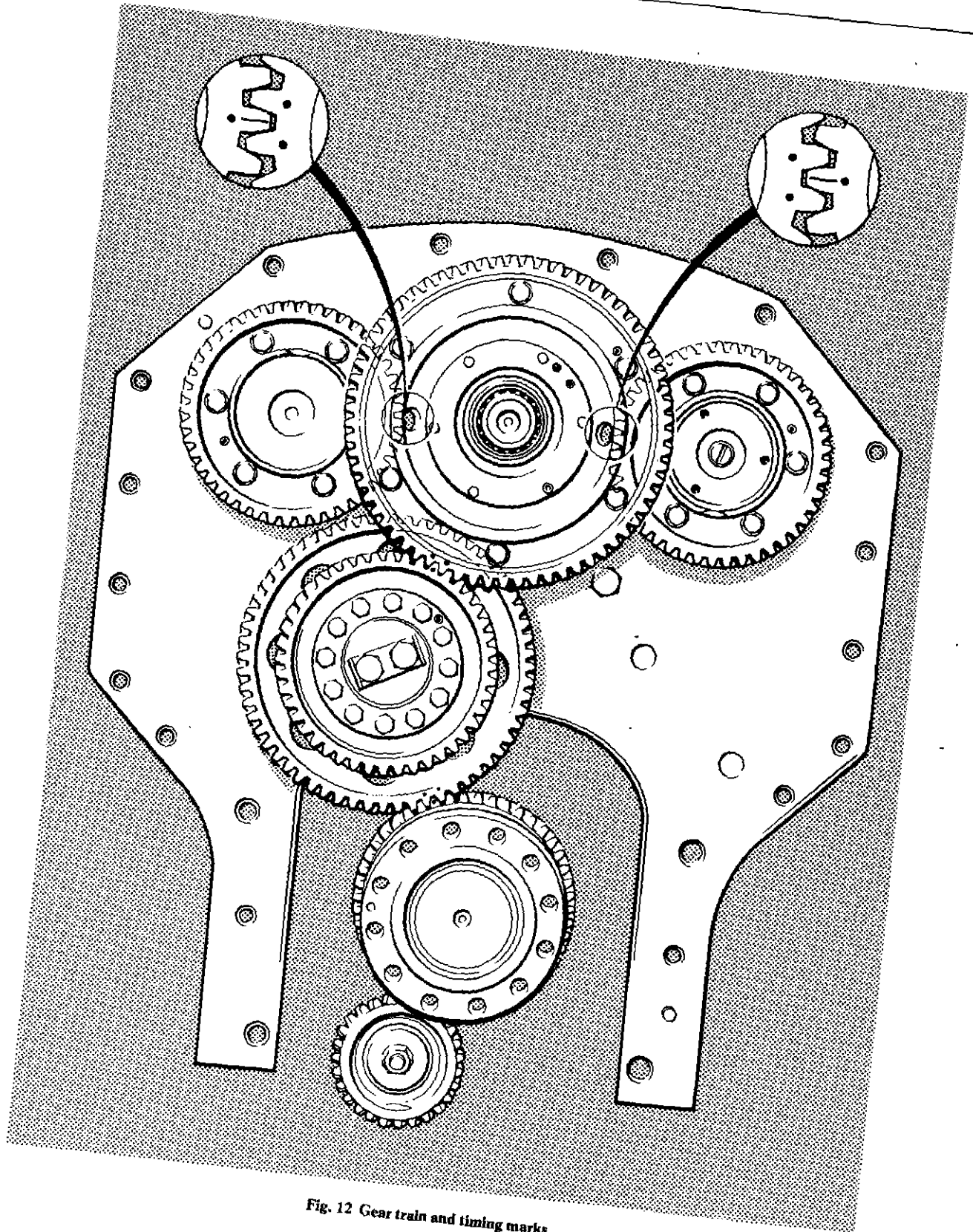

Fig. 12 Gear train and timing marks.

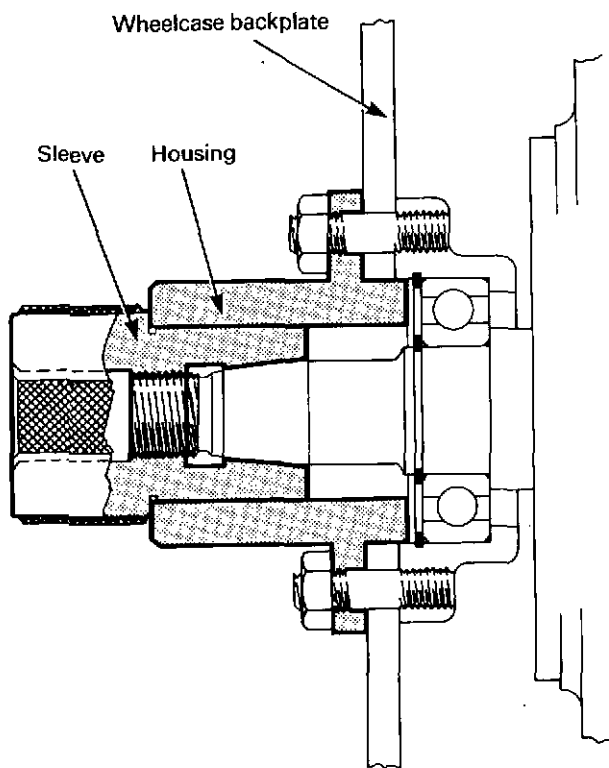

Fig. 13 Alignment tool in position.

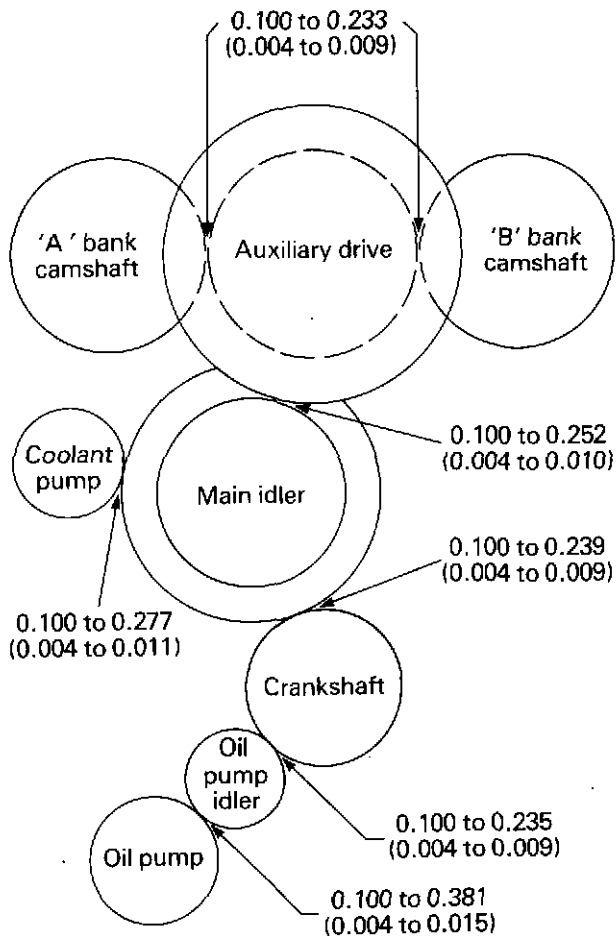

Fig. 14 Gear train backlash readings, Metric [Imperial].

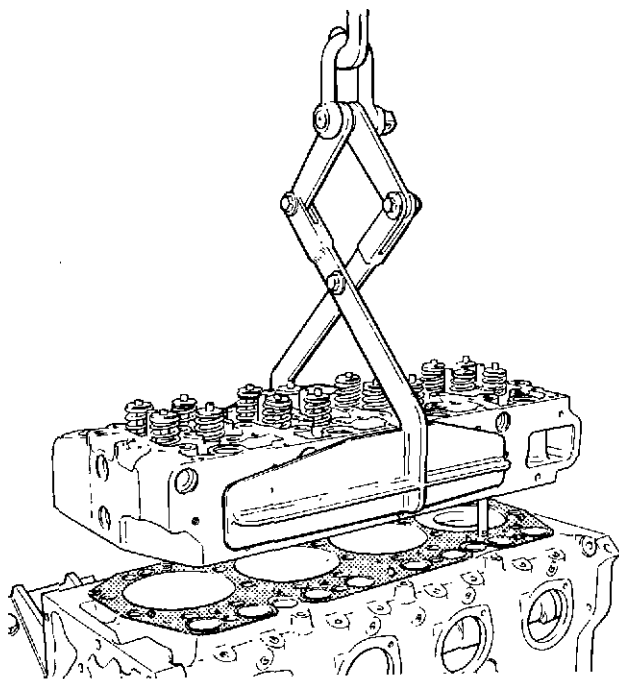
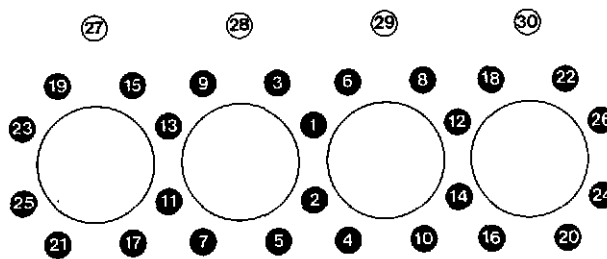

Fig. 15 Fitting cylinder head.



Figures in black circles.....240 Nm. (175 lbf./ft.)
 Figures in white circles.....175 Nm. (130 lbf./ft.)
 plus 1/6 turn

Fig. 16 Cylinder head bolt torque tightening sequence.

46. Remove the lifting bracket and guide studs and lightly oil the cylinder head bolt threads. Fit all the bolts and washers complete with lifting eye, radiator stay bracket and exhaust bellows support bracket.
47. Following the correct sequence, tighten the cylinder head bolts in steps of 50 Nm (38 lbf. ft.), until the final torque figure is achieved.
48. Fit new 'O' ring seals around the four alloy blanking plugs. Lubricate the rings with castor oil and press the plugs into the access holes in the induction ports.
49. Turn the engine so that the 'B' bank flame face is horizontal and fit the cylinder head using the same procedure as that used on 'A' bank, then turn the engine upright to its normal position. If new cylinder heads have been fitted, stamp the bank letter on each head for future reference.
50. Fit the heat shield/lifting eye to the rear end face of the crankcase with one setbolt and spring washer. Ensure that all the bolt holes are aligned with those in the crankcase before tightening the setbolt.
51. Fit the turbocharger mounting duct to the heat shield, over the three studs protruding through the crankcase; fit the setbolt, with a spring washer, and fit nuts and spring washers to each stud. Tighten each nut and bolt securely.

Flywheel and housing

52. Screw two Guide Studs, VT 17844, into the crankcase/flywheel housing bolt holes and, using the Lifting Beam, VP 5014, position the flywheel housing over the guide studs. Secure the housing to the crankcase with ten setbolts and spring washers and two bolts, nuts and spring washers. Remove the guide studs and fit the two remaining setbolts and spring washers. Torque tighten each bolt to 95 Nm (70 lbf. ft.).
53. Check that the spring dowel is fitted in the crankshaft rear end flange and using the Lifting Bar, VP 5008, position the flywheel on the crankshaft.
54. Fit the clamping ring and secure the flywheel with 16 socket head capscrews. Torque tighten the capscrews to 315 Nm (232 lbf. ft.).

55. Screw the timing pointer into the flywheel housing and using new gaskets and spring washers, fit the blanking covers each with two setbolts. Fit the plug complete with new joint washer.

At this stage, the coolant gallery covers may be fitted, using new jointing gaskets, followed by the coolant rail and hose connection heat shield.

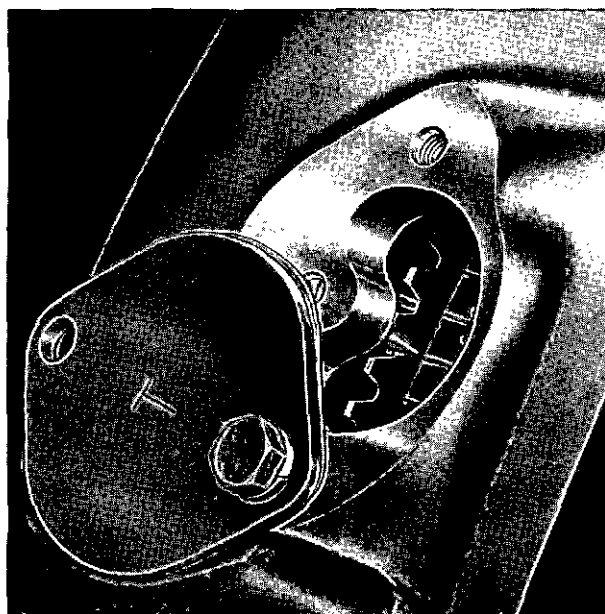

Fig. 17 Flywheel timing pointer.

Valve gear

56. Insert the 16 pushrods through the cylinder head apertures and check that the 4 rocker box locating spring dowels are in place.
57. Liberally oil the valve bridge guides, bridge pieces and pushrods and position the rocker box gaskets over the locating dowels in the cylinder head top face.
58. Ensure that the rocker adjusting screws are all slackened right back, then fit the rocker box assemblies on to their respective cylinder heads.
59. Fit the rocker box securing setbolts with plain and spring washers, and fit the socket head capscrews. Tighten the setbolts and capscrews evenly and progressively to the following torque loadings.

Setbolts41 Nm (30 lbf. ft.)
Capscrews35 Nm (26 lbf. ft.)

The following sequence, specified in Items 60 to 65 inclusive, applies to engines fitted with the Cruciform crankshaft, CV 7693. For engines fitted with the Paired Throw crankshaft, CV 2457, the correct sequence will be found in the table given below.

- 60. Rotate the crankshaft until the piston in the 'B3' cylinder is at T.D.C. on its compression stroke with the valves on 'A1' 'rocking', i.e. exhaust valves just closing, inlet valves just opening.
- 61. Slacken the locknuts on the 'B3' bridge piece adjusting screws and turn each screw back until it is clear of its valve stem. In turn, press down firmly on the centre of each bridge piece and turn the adjusting screw until it is felt to just touch the valve stem tip. Turn the screw a further 60 deg. (1/6 turn) and tighten the locknut to a torque loading of 40 Nm (30 lbf. ft.).

Caution: It is important that no side load is placed on the valve stems when tightening the adjusting screw locknuts.

Note: The bridge piece setting may be carried out during cylinder head overhaul, before fitting the rockers, if preferred.

- 62. Using a set of feeler gauges, set the clearance between the inlet valves rocker adjusting screw and valve bridge button to 0.2 mm (0.008 inch) and tighten the locknut to 40 Nm (30 lbf. ft.).
- 63. Set the clearance between the exhaust valves rocker adjusting screw and bridge button to 0.5 mm (0.020 inch), and torque tighten the locknut as for the inlet valves.

Note: Re-check the inlet and exhaust valve clearances after torque tightening the locknuts before proceeding to the next unit.

- 64. Rotate the crankshaft through 90 deg. in the normal direction of rotation. This will bring the 'A2' piston to T.D.C. on its compression stroke with 'B1' valves 'rocking'. Set the valve bridge as described in Item 62, if not previously adjusted.
- 65. Set the 'A2' tappet clearances as described in Items 63/64 and proceed in 90 deg. steps until all units have been adjusted.

Note: See the tappet setting sequence given at bottom of page.

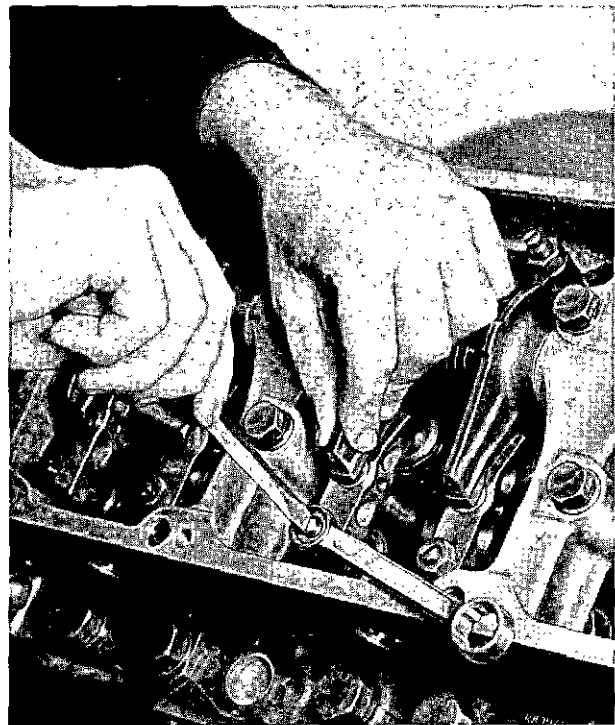

Fig. 18 Setting valve bridge pieces.

Crankshaft CV 7693		Crankshaft CV 2457	
Valves rocking on	Set clearance on	Valves rocking on	Set clearance on
A1	B3	A1	B3
B1	A2	B1	A4
B2	A4	A2	B4
A3	B4	B2	A3
B3	A1	B3	A1
A2	B1	A4	B1
A4	B2	B4	A2
B4	A3	A3	B2

Fig. 19 Tappet setting sequence

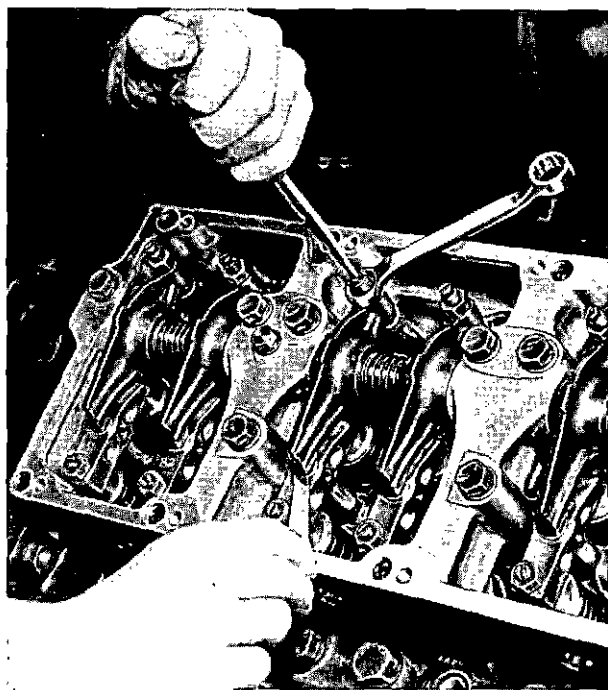

Fig. 20 Setting valve tappet clearance.

Oil test

When the engine has reached this stage it is advisable to apply an oil test to ensure that the moving parts are adequately lubricated, and to check that oil seals are not leaking. An oil circuit Test Trolley VP 4000 is available for this purpose.

66. Fit the oil test union to the turbocharger oil feed aperture in the crankcase 'V' and connect the oil pipe from the test trolley. Switch on the electric pump.
67. Check for a good flow of oil from any of the fixed oil jets and a liberal supply from the main bearings, connecting rod big and small end bearings, all idler gear axles, the rocker arm bushes and a flow from the rocker arm drillings to supply the push rods and valve gear.
68. Check that there is no leakage from any of the crankshaft cup and sludge plugs, and the cup plugs and blanking plugs in the auxiliary oil galleries.
67. Switch off the test pump, disconnect the oil pressure pipe and remove the pipe union from the crankcase 'V'.
70. Temporarily fit the rocker box covers to protect the valve gear.

Wheelcase

If, during overhaul, the two studs to the right of the 'B' bank camshaft bore have been removed from the crankcase end face, they must be replaced before fitting the wheelcase.

71. Coat the threads with 'Loctite 542' and screw in the two securing studs.
72. Apply a coating of 'Wellseal' to both sides of the wheelcase joint gasket and position the gasket on the backplate.
73. Using two Guide Studs, VT 17845, assemble the wheelcase to the backplate and secure with setbolts and nuts, with plain and spring washers. Torque tighten the nuts and setbolts to 95 Nm (70 lbf. ft.).

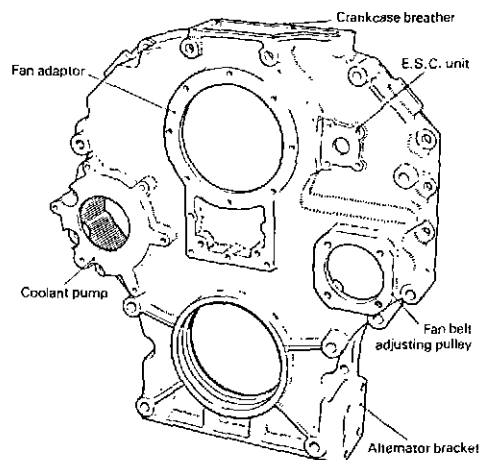

Fig. 21a Wheelcase, CV 8095 with parts locations.

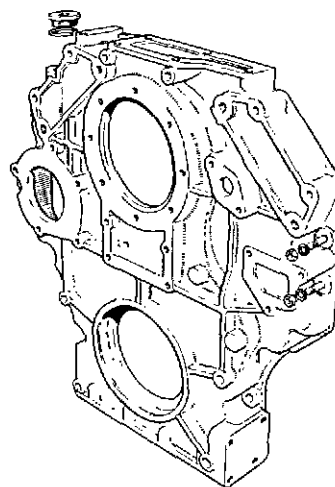

Fig. 21b Wheelcase, CV 2680.

74. Coat the fan adaptor gasket with 'Wellseal' and fit the assembly to the wheelcase. Secure the assembly with setbolts and spring washers.
75. Apply a coating of 'Wellseal' to each side of the breather connection gaskets. Fit a gasket, baffle plate, the second gasket and finally the breather connection to the aperture in the wheelcase top face. Secure the connection with five setbolts, plain and spring washers.
76. Remove the auxiliary drive alignment tool and turn the crankshaft backwards and forwards, sufficient to note the full axial movement of the auxiliary drive shaft. Set the shaft at approximately mid-point of its travel and fit the oil seal housing, complete with a full laminated shim pack, over the studs on the engine side of the back plate. Nip up the six securing nuts. Set up a D.T.I. gauge in the crankcase 'V' with the indicator lever resting on the end of the auxiliary drive shaft. Rock the crankshaft backwards and forwards and note the D.T.I. readings. The correct end float for the auxiliary drive shaft assembly is 0.08 to 0.12 mm (0.003 to 0.005 inch). Remove layers from the laminated shim and check the axial movement of the assembly until the correct reading is achieved. Finally secure the oil seal housing and shims with the six nuts and Dowty washers and refit the woodruff key.

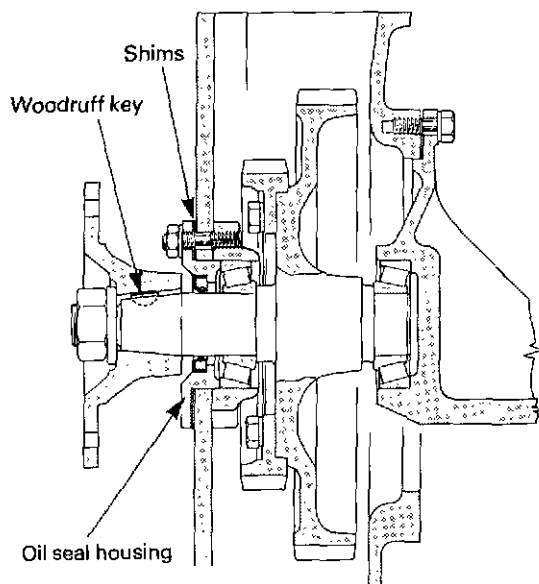

Fig. 22 Auxiliary drive assembly.

Coolant pump

77. Remove the suction cover from the coolant pump assembly and using a dry gasket, temporarily secure the pump to the wheelcase with two or three setbolts and plain washers.
78. Set up a D.T.I. gauge with the lever against one of the coolant pump impellor blades at a point 44 to 45 mm radially from the centre of the shaft. Turn the impellor by hand to the limit of its movement in both directions and check the backlash reading on the gauge. The total reading should be between 0.100 and 0.277 mm (0.004 and 0.011 inch).
79. Remove the coolant pump, coat the gasket with 'Wellseal' and refit the pump to the wheelcase complete with the suction cover. Secure with setbolts, plain and spring washers.
80. Fit the by-pass suction connection to the pump cover flange with a joint gasket and, dependent upon the type of coolant pump used, secure the connection with three setbolts with plain and spring washers or three bolts and nuts with plain and spring washers. Slide a hose connection and two hose clips over the free end of the by-pass suction connection.

Oil pump and sump

Turn the engine over so that the sump face is uppermost

81. Fit the oil baffle plate to the crankcase and secure with four setbolts and spring washers.
82. Fit two locating dowels into the crankcase sump face and secure the oil pump assembly in position with three setbolts and spring washers.
83. Fit the oil pump drive gear with a locking washer and retaining nut. Torque tighten the nut to 120 Nm (88 lbf. ft.), and tab up the washer. Check the gear backlash. See figure 14.
84. Fit the rubber 'O' rings to each end of the oil suction pipe, smear the rings with castor oil and insert one end of the pipe into the oil pump casing.
85. Fit the suction connection to the free end of the suction pipe and secure with two setbolts and spring washers.
86. Fit new 'O' rings to the suction bobbin, lubricate with castor oil, and insert the bobbin in the aperture in the suction connection.

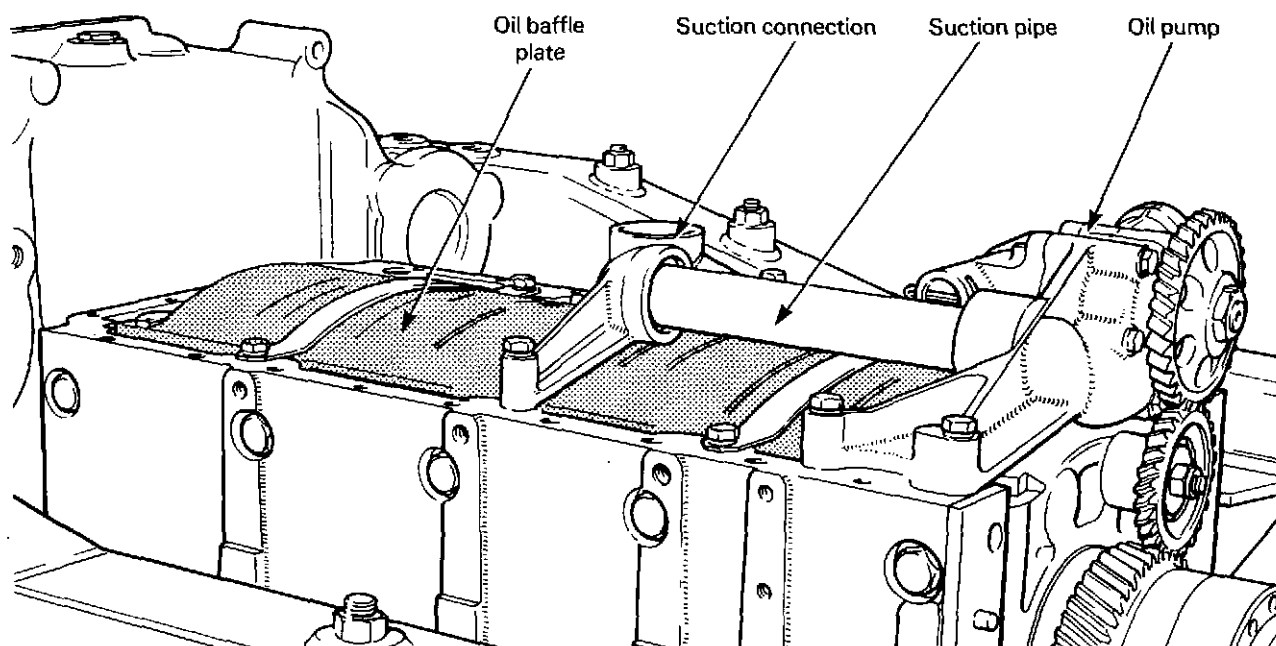

Fig. 23 Oil pump and baffle plate.

87. Apply 'Wellseal' to both sides of the sump joint gasket and position it on the crankcase sump face, then fit two Guide Studs VT 10723 into the setbolt holes.
88. Lower the sump assembly on to the crankcase, remove the two guide studs and fit the 28 setbolts with spring washers. Torque tighten the setbolts to 55 Nm (40 lbf. ft.).

Induction manifolds

Turn the engine to its normal operating position.

89. Fit new 'O' rings to the eight coolant bobbins, lubricate with castor oil and insert the bobbins into the cylinder head apertures.
90. Fit the two induction manifold gaskets to the cylinder head inner machined faces and secure the two lower sections of the induction manifolds to their respective cylinder heads with 24 setbolts and spring washers.
91. Fit the upper sections of the induction manifolds to the lower sections with joint gaskets and 28 setbolts with plain and spring washers.
92. Fit the two blanking plates, with gaskets, to the rear end of the manifold lower sections using setbolts and spring washers.

93. Fit the two elbow connections, with gaskets, to the front end of the lower manifold sections and secure each elbow with four setbolts, plain and spring washers.
94. Slide a hose connection and two hose clips on to each elbow. Fit the thermostat connecting pipe to the 'A' bank elbow and position the hose and hose clips over the joint. Slide a hose connection and two hose clips over the free end of the pipe.

Thermostat

95. Fit the thermostat assembly on to the engine breather and secure with four setbolts and spring washers; slide the hose connections over the elbow and connecting pipe joints and align and tighten the six hose clips.
96. Slide a hose connection and two hose clips over the thermostat by-pass outlet and fit the connecting pipe between the thermostat and coolant pump connection. Position the two hoses and align and tighten the four hose clips.

Exhaust manifolds

97. Using the Stud Box, VT 11685, insert the 16 studs in each cylinder head exhaust manifold joint face.

98. Using the Stud Box, VT 11684 screw in the six lockplate securing studs at the exhaust manifold coupling positions.
99. Fit the sealing rings and sealing pipes, complete with lockplate, into their respective duct or manifold bores; fit plain washers and nuts to each stud and tighten securely.
100. With the front and rear sections of the manifolds closed up as single units, offer each assembly up to its cylinder head joint face. Ensure that each sealing ring and sealing pipe is housed correctly at each end, fit 16 plain washers and nuts to the manifold retaining studs and tighten securely.

Fuel feed pump

Turn the crankshaft until the fuel feed pump drive cams on the 'A' bank camshaft are in a 'neutral' position, prior to fitting the pump and its adaptor.

101. Fit the fuel feed pump adaptor complete with new 'O' ring, to the crankcase. Ensure that the

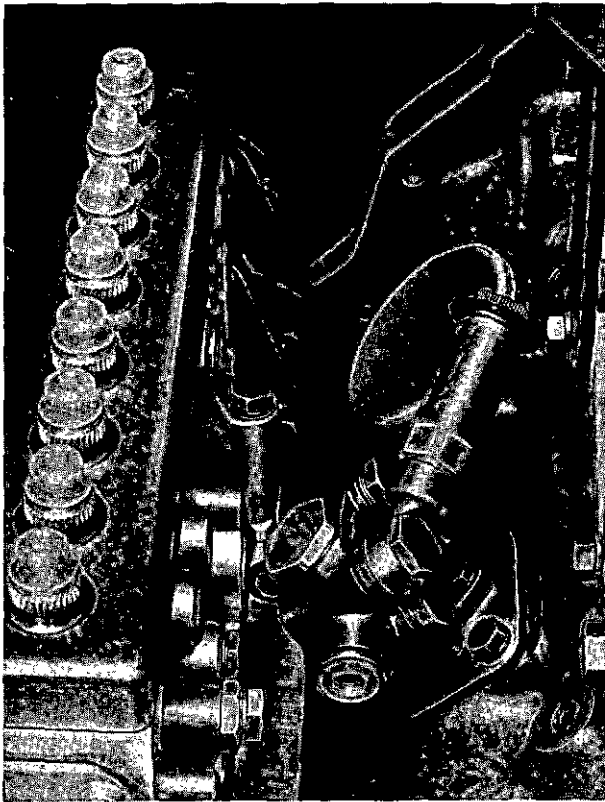

Fig. 24 Fuel feed pump.

pump securing bolt holes in the adaptor are so positioned that the pump may be mounted in its correct operating position, (see illustration). Secure the adaptor with two setbolts and spring washers.

102. Fit the fuel feed pump, complete with gasket, to the adaptor and secure with three setbolts and spring washers.

Shutdown solenoid

103. Fit the sandwich plate to the shutdown solenoid with one bolt nut and spring washer and position the assembly on its mounting bracket. Insert three setbolts with spring washers and secure to the bracket with the control rod facing towards the rear of the engine.

Note: On engines having the solenoid attached to the induction manifold, no sandwich plate is fitted between the solenoid and mounting bracket.

Fuel injection pump mounting

104. Tap the two locating dowels into the fuel injection pump mounting plate and secure the plate in the crankcase 'V' using five setbolts and new spring washers.

Auxiliary drive coupling

Remove the 'B' bank cylinder head rocker cover and turn the crankshaft, in the normal direction of rotation, until 'B1' piston is at T.D.C. on its compression stroke. At this point the woodruff key fitted in the auxiliary drive shaft will be facing upwards.

105. Assemble the coupling drive flange with one pack of six spring drive plates, two bolts, two long reach nuts and four washers, as shown in the illustration. Torque tighten the nuts to 120 Nm (88 lbf. ft.).
106. Ensure that the woodruff key is firmly set in the auxiliary drive shaft and fit the spring drive assembly on to the shaft. Screw the retaining nut on to the shaft with the plain washer and torque tighten to 200 Nm (149 lbf. ft.).

Note: The above torque figure applies to nuts with 18 mm diam. threads. For shafts fitted with the 22 mm nut the torque loading must be 300 Nm (221 lbf. ft.).

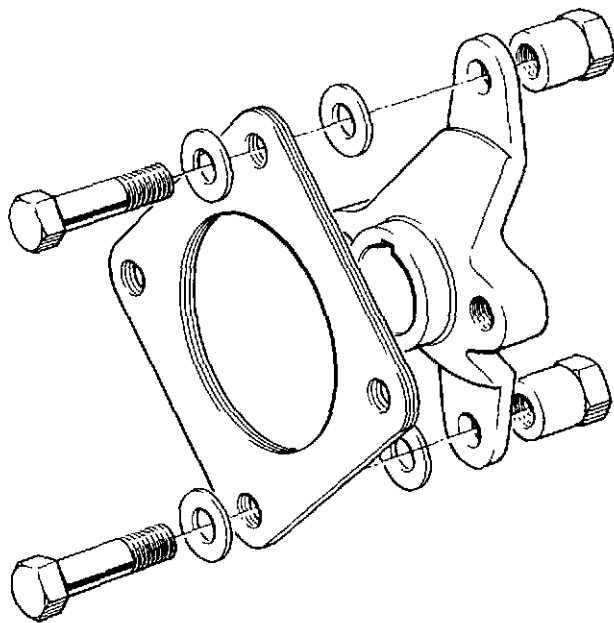

Fig. 25 Auxiliary coupling drive flange.

To assist in setting the fuel injection timing, it is recommended that a mark be made on the top edge of the coupling flange corresponding to the position of the woodruff key. If the crankshaft is inadvertently turned before the fuel injection pump is fitted, the 'B1' piston will be in the correct position for setting the fuel injection timing when the marked arm of the flange is uppermost.

107. Check that the operating lever has been fitted to the fuel injection pump speed control lever, situated on the 'A' bank side of the governor

housing, then slacken the four securing bolts on the pump drive hub and remove the drive flange and clamping plate.

108. Assemble the adjustable coupling plate with the pack of six spring drive plates, the two short securing bolts, four washers and long reach nuts as shown in figure 26. Torque tighten the nuts to 120 Nm (88 lbf. ft.). Push the long coupling bolts through the spring plate bolt holes with a plain washer beneath each bolt head.

109. Using a spanner on the pump hub nut, turn the hub until the timing mark is opposite the pointer and fit the spring plate assembly to the pump with the clamping plate and four setbolts with spring washers. Do not tighten the clamping bolts at this stage.

110. Fit two washers over the long coupling bolts, slide on the coupling yoke, ensuring that the cross connecting arm is away from the pump hub, then fit two more washers on to the protruding ends of the coupling bolts.

Fuel injection pump

111. Lift the pump into the engine 'V' and slide it forward on its mounting plate until the two long coupling bolts pass through the bolt holes in the spring plate drive coupling. Fit two more washers and run the two nuts on to the bolts. Do not tighten the nuts.

112. Fit the four setbolts into the fuel injection

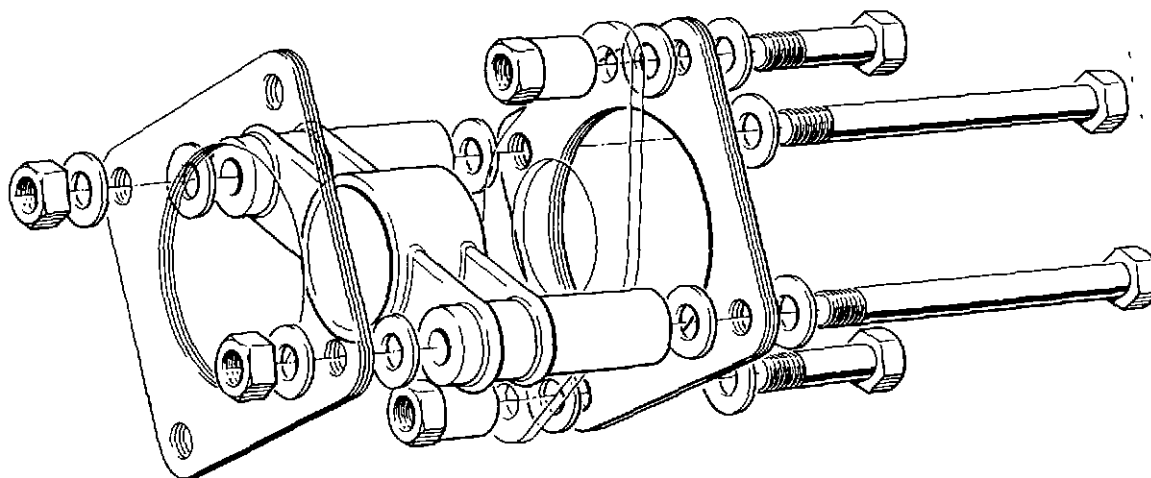

Fig. 26 Auxiliary drive coupling assembly.

pump housing, with plain and spring washers, and secure the pump to its mounting plate. Torque tighten each setbolt to 41 Nm (30 lbf. ft.).

113. Torque tighten the long coupling bolts and nuts in the drive coupling to 120 Nm (88 lbf. ft.).

Injection pump timing

114. Remove the timing pointer cover from the flywheel housing, check the engine data plate for the correct timing and turn the crankshaft until the timing marks are aligned, figure 17.
115. Check that the 'B1' cylinder valves are closed, with the 'B1' piston at T.D.C. on compression stroke.
116. Turn the fuel injection pump hub by hand until the timing mark overshoots the fixed pointer, then carefully turn the hub back until the marks are aligned. Tighten the four clamping setbolts securely.

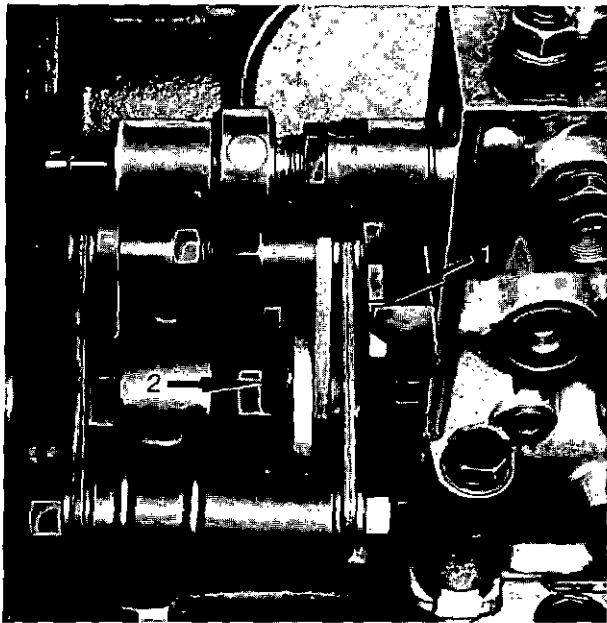

Fig. 27 Injection pump timing marks.

1. Timing marks. 2. Clamping setbolts.

Turn the crankshaft back approximately one quarter of a revolution then forward again until the flywheel timing marks are correctly aligned. Check the alignment of the fuel injection pump timing marks and readjust if necessary, then refit the flywheel timing pointer cover and remove the barring ring from the crankshaft front end.

Governor controls

117. Remove the rubber cover from the terminal block at the end of the shutdown solenoid so that the switch gear is exposed and screw the control rod into the ball joint coupling on the stop control lever. Leave the control rod locknuts slack to allow for adjustments.
118. Operate the unit manually and check that the switch opens when the plunger is pressed fully home. By exerting more pressure on the plunger, a further movement of 0.5 to 0.8 mm (0.02 to 0.03 inch) should be obtainable as the spring in the spherical joint is compressed. If necessary, adjust the length of the control rod to achieve the above requirements then tighten both locknuts commencing with the locknut at the plunger end of the rod. Re-check the movement after tightening the locknuts.

Caution: Incorrect adjustment of the control rod can cause damage to the governor linkage or may prevent the isolation of the solenoid pull-in coil, resulting in an overheated unit and failure of the windings.

119. Assemble the speed control rod and support bracket as in the illustration. Run the locknut well up the lower threaded end of the rod and screw the rod into the ball joint connection on the governor speed control lever. Position the bracket over the bolt holes in the top of the 'A' bank induction manifold and secure with two setbolts and spring washers.

Fuel injectors

120. Remove the 'A' bank rocker cover and check all the copper injector sleeves on each bank for cleanliness.
121. Unscrew the spill connection from each injector in turn and ensure that new copper sealing washers and outer rubber seals have been fitted.
122. Slide the injector body into its sleeve and screw in the spill connection through the wall of the rocker box.
123. Fit the injector clamp and socket capscrew. Torque tighten the capscrew to 60 Nm (44 lbf. ft.) then torque tighten the spill connection to 27 Nm (20 lbf. ft.).

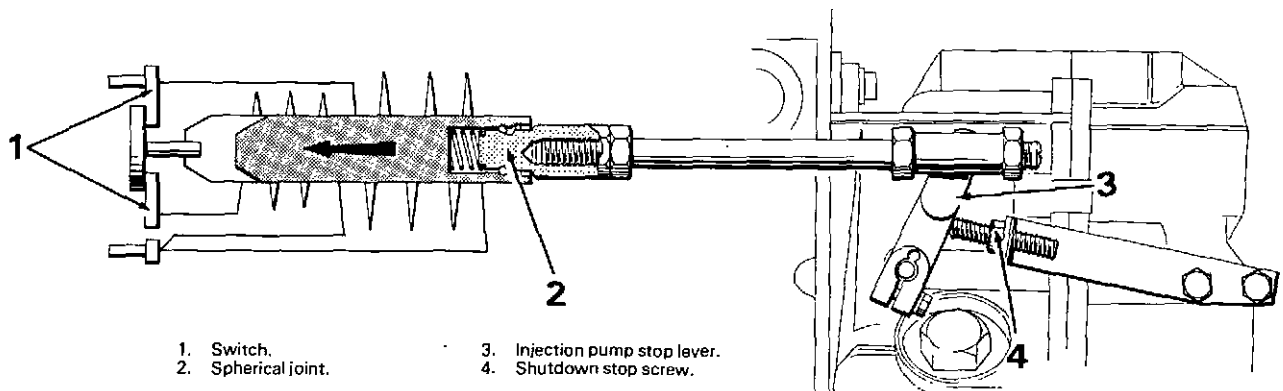

- 1. Switch.
- 2. Spherical joint.
- 3. Injection pump stop lever.
- 4. Shutdown stop screw.

Fig. 28 Solenoid stop control linkage.

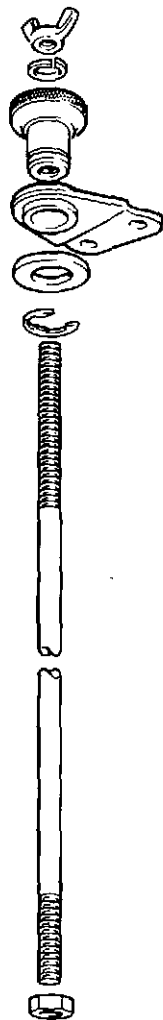

Fig. 29 Speed control linkage.

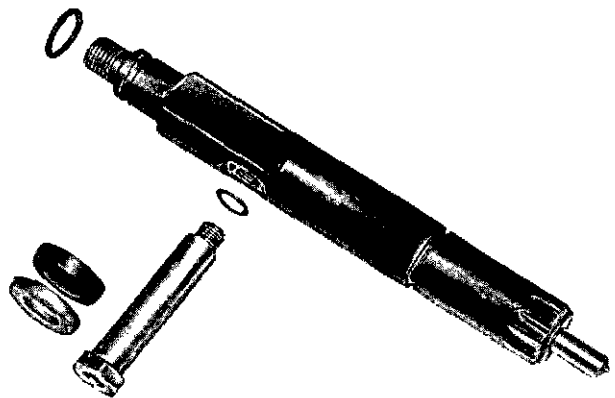

Fig. 30 Bosch fuel injector assembly.

When all the fuel injectors are fitted, remove the dust caps from the high pressure inlet connections and check that each injector is fitted with new rocker cover 'O' ring seals.

- 124. Lightly oil the 'O' ring seals and fit the rocker covers to each rocker box with new gaskets. Do NOT apply jointing compound to the gaskets. Fit the ten securing setbolts with plain and spring washers and torque tighten to 21 Nm (15 lbf. ft.). Refit the injector dust caps.

Alternator

- 125. Fit the alternator mounting bracket to the wheelcase and secure with four setbolts and spring washers.
- 126. Fit the adjusting arm to the wheelcase and lightly secure with the long pivot/setbolt and spring washer.

127. Position the alternator in the mounting bracket and fit the alternator pivot bolt through the bracket and alternator housing. Fit the nut with plain and spring washers.
128. Position the adjusting arm so that the adjusting bolt can be fitted through the slot and the bolt hole in the lug on the alternator housing. See Figure 32.

Note: A plain washer must be fitted between the bolt head and adjusting arm, and a spring washer and nut behind the lug. Do NOT tighten any bolts at this stage.

Pulleys and drive belts

129. Fit the inertia ring to the front end of the crankshaft and tap in the spring dowel, then fit the crankshaft pulley up to the inertia ring and screw in the twelve securing setbolts with spring washers. Torque tighten the setbolts to 95 Nm (70 lbf. ft.).
130. Fit the belt tensioner pulley and bracket assembly to the wheelcase with a new gasket and nip up the securing setbolts. Check the pulley for alignment with the crankshaft pulley by placing a straightedge across the end of the belt tensioner pulley. Add shims, between the bracket back plate and the joint gasket, to give the necessary alignment. When the pulley is correctly aligned secure the assembly to the wheelcase with four setbolts and spring washers.

Note: On engines fitted with Wheelcase, CV2680, a Distance Piece, CV5325, must be fitted behind the outer edge of the bracket assembly as a support for the large diameter setbolt.

On all engines, the upper two setbolts of the bracket assembly are used to secure a smaller bracket which supports the engine breather pipe.

131. Fit the fan drive pulley to the adaptor assembly and nip up the six securing setbolts. Check the pulley alignment with the crankshaft drive pulley and add shims between the adaptor assembly coupling flange and the inner face of the fan pulley, to give the necessary alignment. When the correct alignment is achieved secure

the fan pulley to the adaptor with the six setbolts and spring washers.

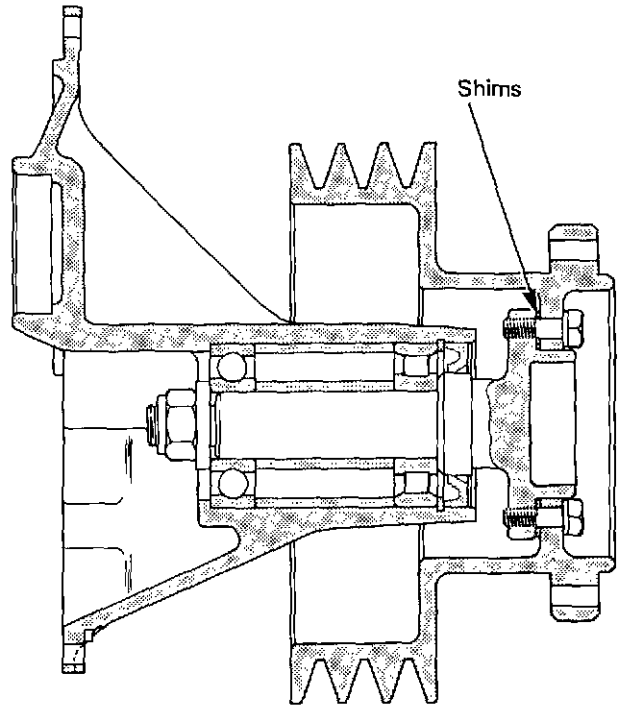

Fig. 31 Fan adaptor and drive pulley.

132. Fit the front mounting and secure to the engine with six setbolts and spring washers.
133. Place the two alternator drive belts over the crankshaft drive and alternator pulleys. Adjust the belt tension by swivelling the alternator about its pivot bolt until the deflection at mid-point of each belt is 12 mm (0.5 inch) under a pressure of 3 to 4 kgf. (7 to 8 lbf.). When the correct tension is achieved, tighten the two adjusting arm bolts and the alternator pivot bolt securely.

Note: On engines fitted with the Butec A3024 alternator, only one drive belt is required.

134. Move the fan belt tensioner pulley to its 'slack' position, i.e. in towards the centre line of the engine, by slackening the large locknut and turning the adjusting bolt accordingly. Fit the three fan belts over the crankshaft, tensioner and fan drive pulleys and turn the adjusting bolt until the deflection at the arrow, shown in

figure 34 for each belt is 20 mm (0.75 inch) under a pressure of 3 to 4 kgf. (7 to 8 lbf.). When the correct tension is achieved, tighten the large locknut securely.

Engine Service Counter

135. Position the Engine Service Counter (E.S.C.) tang in the slot in the drive adaptor at the front end of the 'B' bank camshaft. Fit the four clamps, with setbolts and spring washers and turn the E.S.C. unit until the window is in the desired viewing position before tightening the setbolts.

Note: On engines fitted with Wheelcase CV 2680, only two setbolts are used to secure the E.S.C. unit.

Turbocharger

Check that the exhaust manifold turbocharger mounting flange is clean and undamaged and examine the corresponding joint face of the turbocharger. As this is a metal to metal joint, any dirt or damage could cause leakage of exhaust gases.

136. Fit the turbocharger on to its mounting and secure with four nuts and plain washers.

The exhaust gas outlet from the turbocharger may be one of two types of fitting. The flat face type is fitted with six studs to accept a normal flange connection; the recessed face type without studs accepts a spigot connection which is secured with a 'V' hand clamp. Fitting instructions for each type are given below.

137. Ensure that the joint faces are clean and undamaged and proceed as follows.

(a) Spigot type

Pass the bellows of the diffuser through the circular cut out in the support bracket and enter the spigot into the recessed turbocharger exhaust outlet. Line up the large flange bolt holes with those in the bracket and loosely fit the six securing bolts through the bracket and joint flange to position the bellows unit. Slide a 'V' band clamp around the periphery of the spigot joint and lightly nip up the clamp nut.

Fit the special corrugated steel gasket over the protruding coupling bolts and position the exhaust elbow on the bracket end of the

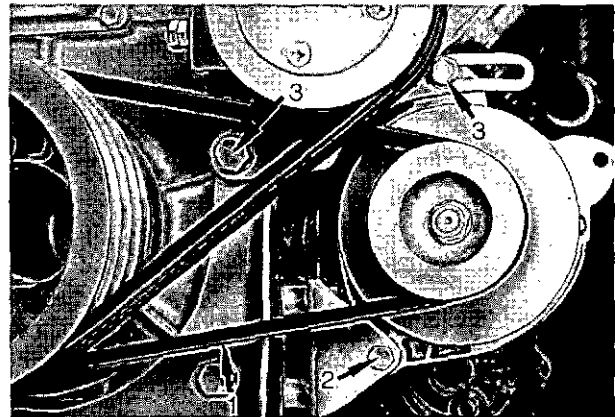

Fig. 32 Alternator belt adjustment.

1. Deflection test point. 2. Pivot bolt. 3. Adjusting arm bolts.

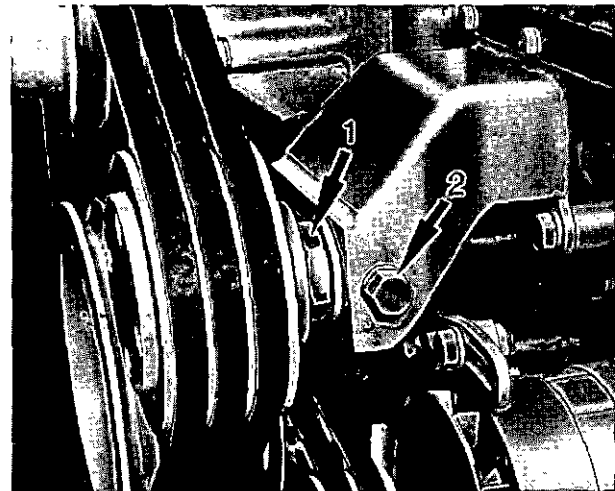

Fig. 33 Fan belt adjustment.

1. Locknut. 2. Adjusting bolt.

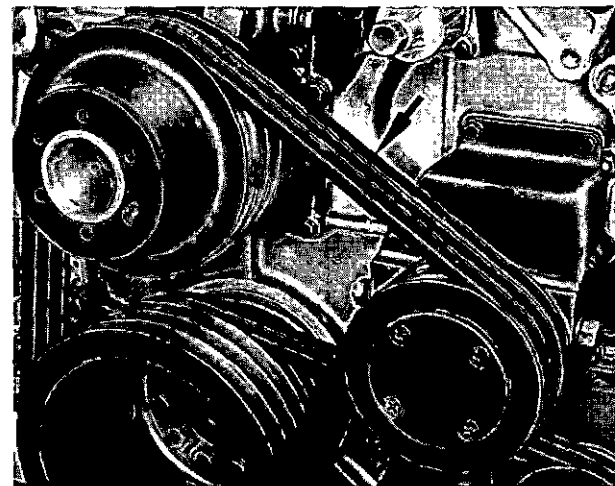

Fig. 34 Fan belt deflection test point.

bellows unit. Screw on six nuts with spring washers and tighten securely.

Torque tighten the 'V' band clamp nut as follows:

On multi-segment clamps, tighten the nut to 13.5 Nm (10 lbf. ft.) then turn the nut a further 120° and, without disturbing the connection, slacken the nut two or three turns and re-tighten to the original loading i.e. 13.5 Nm.

On single segment clamps tighten the clamp nut to 18 Nm (13 lbf. ft.). There is no necessity to slacken and retighten the nut. Blank off the open end of the elbow.

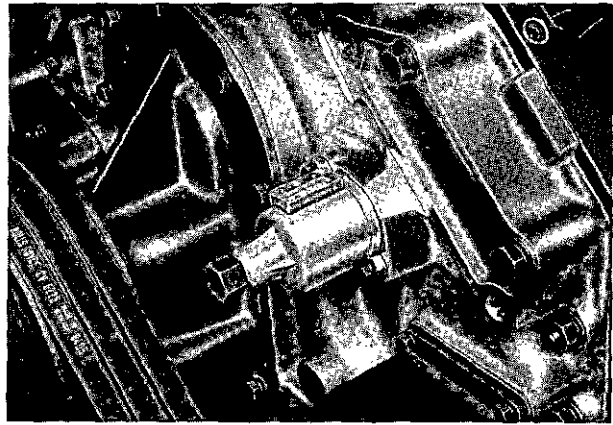

Fig. 35 Engine Service Counter.

(b) Flange type

Fit a special corrugated steel gasket over the six studs in the turbocharger exhaust outlet joint face. Pass the bellows unit through the support bracket aperture and locate over the six studs. Loosely fit the securing bolts through the bolt holes in the bracket and outer bellows unit flange. Screw six nuts with plain washers on to the studs at the inner end of the bellows unit and tighten securely. Fit the larger corrugated steel gasket over the protruding bolts at the bracket end of the unit, position the exhaust elbow over the bolts, screw on six nuts with spring washers and tighten securely. Blank off the open end of the elbow.

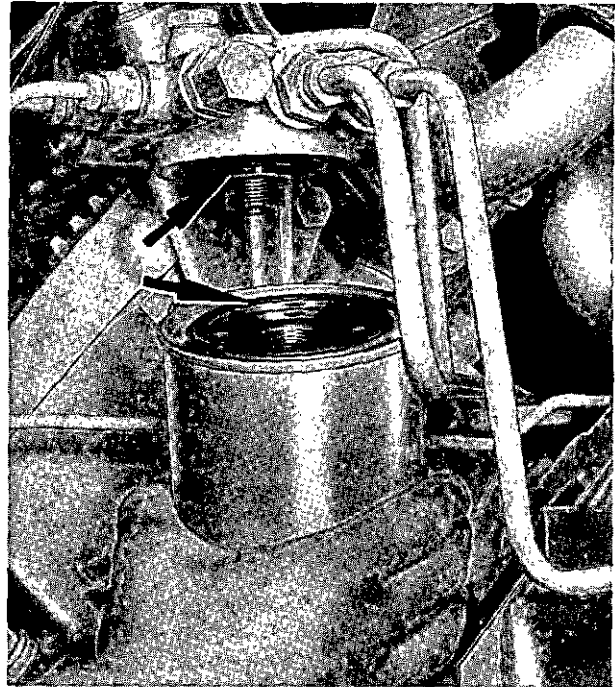

Fig. 36 Fuel filter canister sealing rings.

Fuel filter

138. Fit the fuel filter bracket to the front of the 'A' bank rocker box and secure with two setbolts with plain and spring washers.

139. Fit a new rubber sealing ring around the adaptor union on the underside of the bracket.

140. Fit a new fuel filter canister to the bracket as follows:

Check that the canister is fitted with the outer rubber seal and ensure that the contact faces of the canister and filter bracket are clean. Screw the canister on to the adaptor union until the rubber sealing rings *just* contact their joint faces. Tighten the canister further, by hand, a **MAXIMUM** of three quarters of a turn. **DO NOT** overtighten.

Starter motor

141. Fit the starter motor to the flywheel housing and secure with three setbolts and spring washers.

Oil-to-coolant heat exchanger

142. Prepare the three bobbin connectors for the oil-to-coolant heat exchanger, by fitting four 'O' ring seals to each of the two smaller bobbins

and two 'O' ring seals to the large bobbin. Lubricate each bobbin with castor oil and fit the bobbins in to their pockets. The large bobbin should be pressed into the lubricating oil pump pressure outlet through the sump side wall. Push one small bobbin into the opening leading into the top of the heat exchanger-to-sump elbow connection.

Note: On some engines, the large bobbin is flanged at one end to enable it to be secured to the sump wall with the three elbow securing setbolts. In such cases, only one 'O' ring seal is necessary around the inner end of the bobbin and a jointing gasket must be fitted between the flange and the sump wall.

143. Fit the oil-to-coolant heat exchanger to the crankcase with the gallery bobbin located in the heat exchanger oil outlet. Secure the heat exchanger with four setbolts with plain and spring washers.
144. Lightly coat one side of the elbow connection gasket with 'Wellseal' jointing compound and position the gasket on the sump around the oil pump outlet, with the 'Wellseal' acting as an adhesive.
145. Fit the bobbin/elbow assembly into the aperture beneath the front end of the heat exchanger and secure to the sump wall with three setbolts with plain and spring washers.
146. Slide a hose connection over the heat exchanger coolant inlet with two hose clips, fit the coolant pump discharge connection into the hose and insert a gasket between the pump casing and the flange of the connection. Secure the connection with two setbolts, two bolts and nuts and plain and spring washers. Finally tighten the hose clips securely.
147. Slide a hose connection over the heat exchanger coolant outlet with two hose clips. Fit the end of the connecting pipe into the hose, with the flanged end positioned against the 'A' bank coolant gallery inlet connection. Insert a gasket between the flange and the coolant gallery connection and secure with two setbolts and one bolt and nut with plain and spring washers. Finally tighten the two hose clips securely.

Lubricating oil filters

148. Check that the oil filter contact faces, beneath the oil-to-coolant heat exchanger, are clean and fit two new filter canisters complete with sealing rings. **DO NOT** tighten the canisters at this stage.

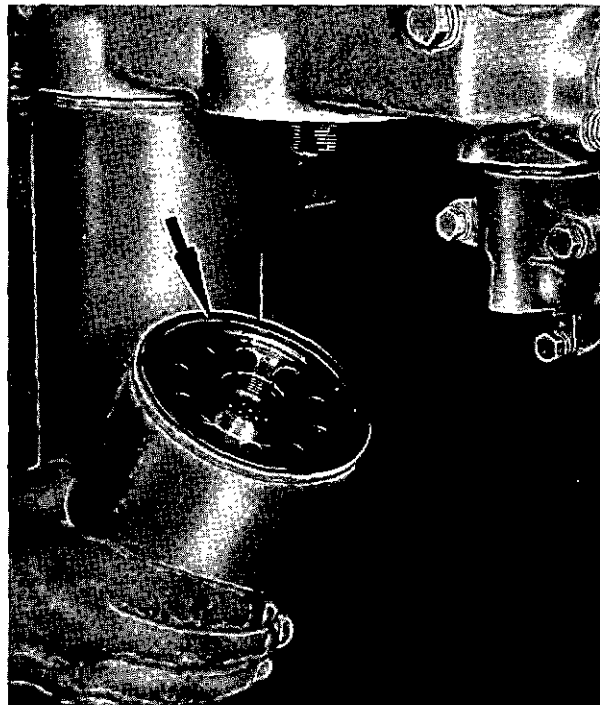

Fig. 37 Oil filter canister sealing ring.

Using the Lifting Beam, VP 5015, support the engine on a suitable crane or hoist; release the engine from the build stand and remove the mounting brackets. Fit transportation feet to the engine front mounting and to the flywheel housing and set the engine down on the workshop floor or work surface.

If transportation stands are not available, the engine may be stood on its sump with suitable packing supporting the front mounting bracket.

Low pressure fuel pipes

149. Fit the oil feed pipe between the discharge adaptor, situated mid-way along the inner wall of the 'B' bank cylinder block, and the fuel injection pump oil inlet adaptor.
150. Fit the fuel injection pump spill pipe to the low pressure relief valve, on the 'B' bank side of the injection pump casing, with the banjo bolt and

two copper sealing washers. Do not tighten any pipe connections until the pipe run is completely coupled.

Fit the down pipe from the fuel interface connection, complete with reducing connector and 'T' piece, and couple up to the pump spill pipe. Add the short connecting pipe and fit the second 'T' piece.

Remove each injector spill connection sealing plug and fit the spill pipe assemblies, with new copper sealing rings, on each side of the banjo unions. Loosely screw in the eight banjo bolts.

Fit the two spill connecting pipes from the second 'T' piece to the injector spill pipe assemblies by removing the banjo bolts from the 'A1' and 'B1' injector spill connections, and passing the banjo bolts through the double banjo unions with a third copper sealing washer beneath each bolt head.

Remove the two appropriate wheelcase securing setbolts and fit two pipe clips, with 'neoprene' inserts, around the 'T' piece-to-'A' bank spill pipe. Screw in the two setbolts with the clip flanges against the wheelcase beneath the plain and spring washers.

Tighten up all connections on the pipe run.

151. Fit the pipe support plate to the front end of the fuel injection pump and secure with two setbolts and spring washers.
152. Fit the fuel suction pipe from the rear end of the fuel feed pump to the union on the interface bracket, with new copper sealing washers on each side of the banjo connection. Align the pipe with the support plate and fit the distance piece between the plate and the neoprene type pipe clip. Secure the clip with a bolt, nut and spring washer. Tighten the banjo bolt and the union connections.

Remove the setbolts with plain and spring washers from the two lower lugs nearest the front end, on the inner side of the 'A' bank induction manifold.

153. Position the fuel feed pump-to-filter header bracket pipe, with new copper sealing washers each side of the feed pump banjo union. Locate the pipe clip, with neoprene insert, over the front lug bolt hole and tighten the pipe connections.
154. Fit the filter header bracket-to-injection pump pipe, locating the two pipe clips, with neoprene

inserts, over the two manifold bolt holes and tighten the pipe connections.

155. Re-fit the two manifold securing setbolts with the plain and spring washers and tighten securely.

Turbocharger oil pipes

156. Slip a hose connection and two hose clips on to the lower end of the turbocharger oil drain pipe. Secure the flanged end with gasket, to the turbocharger oil outlet, using two setbolts and spring washers. Position the hose over the crankcase oil drain adaptor and tighten the pipe clips.
157. Remove the dust cap from the turbocharger oil inlet opening and fit the temporary filter into the aperture with the gasket holes aligned. Fit the oil feed pipe/priming stand pipe assembly to the turbocharger and secure with two setbolts and spring washers at the turbocharger end and the standard pipe union at the crankcase adaptor end.

Caution: The temporary filter must be removed and discarded after the engine has undergone its initial running-in period and a normal jointing gasket fitted in its place.

Injection pump oil drain

158. Fit the fuel injection pump oil drain pipe into the crankcase dual adaptor. Align the banjo connection end with the outlet adaptor in the end of the governor casing; fit the banjo bolt with new copper sealing washers on each side of the banjo union. Tighten each connection.
159. Slip a hose connection over the end of the coolant crossover pipe, complete with two pipe clips, and position the pipe over the flywheel housing. Align the flange with the 'A' bank gallery connection, fit the joint gasket and secure with three bolts, nuts and spring washers. Slide the hose over the 'B' bank gallery connection and tighten the two hose-clips. Finally secure the steadying bracket to the flywheel housing with a setbolt and spring washer.

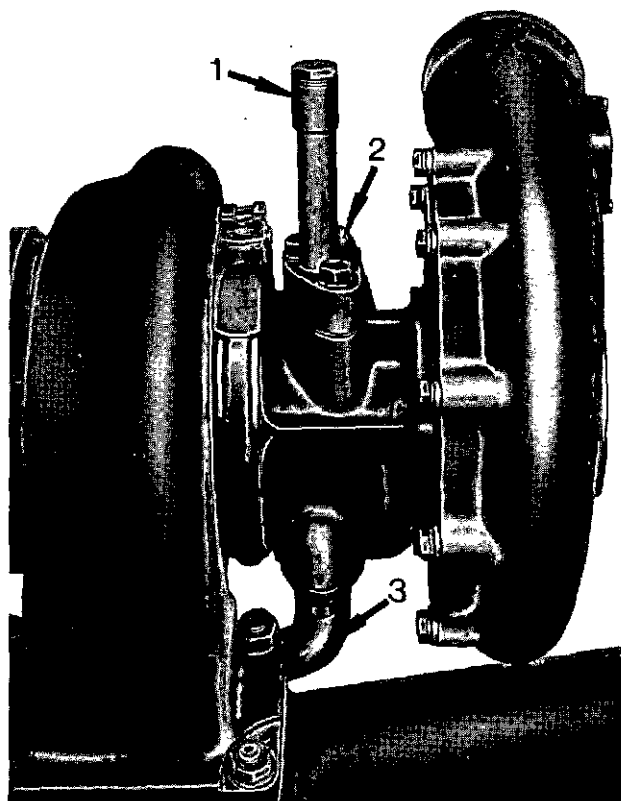

Fig. 38a Holset turbocharger.

1. Primary stand pipe. 2. Oil feed pipe. 3. Oil drain pipe.

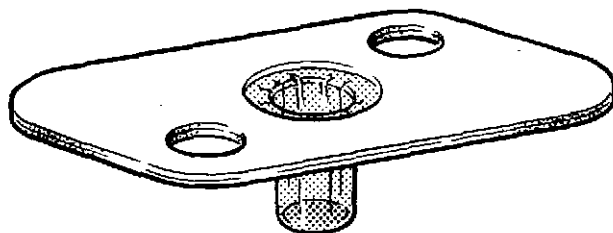

Fig. 38b Turbocharger temporary oil filter.

High pressure fuel pipes

Remove the dust caps from the injector and fuel injection pump high pressure connections and unscrew the shroud setbolts securing the fuel interface bracket to the 'B' bank induction manifold.

160. Loosely fit the injector feed pipes shown in the illustration. Ensure that each pipe is aligned correctly, press the rubber shroud inserts over each pipe, then position the shrouds over the inserts. Tighten the pipe unions taking care not to strain or twist the pipes. Finally, secure the shrouds to the induction manifolds with setbolts and new spring washers.

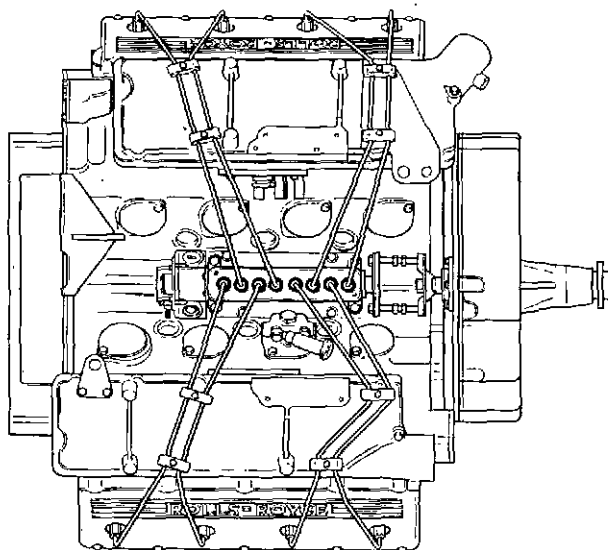

Fig. 39 Injector feed pipe runs.

Oil filler and dipstick

161. Fit the oil filter pipe to the sump with a new gasket and secure with three setbolts and spring washers.
162. Fit the dipstick tube to the tube adaptor in the sump wall and secure with the nut and olive. Place the dipstick in the tube.

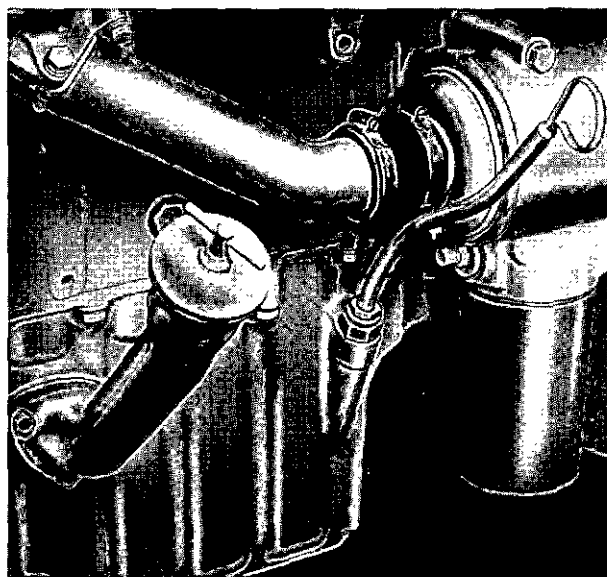

Fig. 40 Oil filler pipe and dipstick location.

Radiator mounting

163. Check the serviceability of the 'Metalastic' bushes in the radiator support brackets; renew if necessary and secure the brackets to the engine front mounting with eight bolts, nuts and spring washers. Position the radiator mounting beam to the brackets and loosely secure with two pivot bolts, nuts and spring washers.

Fan

164. Fit the fan to the fan adaptor with six setbolts and spring washers. Torque tighten the setbolts to 20 Nm (15 lbf. ft.).

Radiator

165. Check the serviceability of the 'Metalastic' bushes in the radiator stay brackets and renew if necessary. Fit the brackets to each side of the radiator complete with distance pieces and secure each bracket with two setbolts and spring washers.
166. Fit the four radiator pipe clip support brackets and secure loosely with one setbolt, plain and spring washer to each bracket.
167. Lift the radiator into position, align the securing bolt holes in the mounting beam and loosely secure with eight bolts, nuts and spring washers. Ensure that the radiator is square to the fan axis and check the gap between the fan blade tips and the radiator cowl. The clearance should be 9.50 to 12.7 mm (0.374 to 0.50 inch). To obtain the correct running clearance, shims must be inserted between the radiator feet and the mounting beam.
Finally, set the radiator stay rods to the correct length and secure the radiator to the cylinder head stay brackets. Securely tighten the pivot bolts and nuts.
168. Check the coolant vent pipe clipping points on the fan cowl casing (see Item 173). Fit the fan guard to the radiator (Cov Rad) and secure with seven setbolts with plain and spring washers. Where a Marston radiator is fitted the fan guard must be secured with 13 setbolts and spring washers.
169. Fit the belt guard to the fan guard and secure

with three setbolts with plain and spring washers and fit the supporting strut from the top of the fan adaptor flange to the belt guard.

Note: After tightening the radiator and guard securing setbolts, check the running clearances of the fan and adjust as necessary before testing the engine.

Air ducts and coolant pipes

170. Check the serviceability of the 'Metalastic' bush in the air duct support bracket and renew if necessary; secure the bracket to the 'A' bank induction manifold using the two front setbolts and spring washers of the blanking cover plate.
171. Slide two hose connections and four hose clips on to the thermostat-to-radiator coolant pipe. Fit the two pipe clips, complete with rubber damper inserts, and locate the pipe between the thermostat and radiator connections. Slide the hoses over each connection; align and tighten the hose clips. Loosely fit the two pipe clips with bolts, nuts and spring washers, to the radiator mounted brackets.
172. Slide two hose connections and four hose clips on to the coolant pump-to-radiator pipe. Fit the pipe clip, with rubber insert, and locate the pipe on the pump and radiator connections. Slide the hoses over each connection; align and tighten the hose clips. Secure the pipe clip to the engine front mounting with a bolt, nut and spring washer.
173. Fit the small bore vent pipe between the thermostat housing and the 'A' bank side of the radiator and tighten the two unions. Slip the two pipe clips with rubber bushes over the pipe and secure to the radiator fan cowl casing with setbolts and spring washers.
- Note:** On some engines the pipe clips are secured to the casing with bolts, nuts and spring washers. In such cases, the pipe must be positioned and the clip bolts tightened before the fan guard is fitted.
174. Slide a hose connection and two hose clips on to each end of the turbocharger-to-radiator air duct. Position the duct over the engine and secure to the support bracket with a setbolt, plain and spring washer. Slide the hose over the

radiator connection, align and tighten the two hose clips. Carefully align the turbocharger compressor housing with the rear end of the duct, slide the hose over the connection, align and tighten the two hose clips. Tighten the ten setbolts around the compressor housing.

175. Slide a hose connection and two hose clips over the top end of the engine breather pipe, position the pipe against the breather housing and slide the hose over the connection. Fit the pipe clip, with rubber insert around the pipe and secure to the support bracket with a bolt, nut and spring washer. Finally, align and tighten the two hose clips.

176. Slide hose connections, each with two hose clips, over the two ends of the lower section of the 'A' bank side induction manifold-to-radiator duct. Position the duct against the radiator outlet, and slide the hose over the connection. Fit the pipe clip with rubber insert over the duct and secure to the lower radiator support bracket with a bolt, nut and spring washer.

Slide a hose connection with two hose clips, over the upper end of the top section of the duct. Position the duct against the manifold inlet and lower duct and slide the two hoses over the connections. Fit the pipe clip around the duct and secure to the upper bracket with a bolt, nut and spring washer. Align and tighten the six hose clips on the three hose connections. Finally fit the three pipe support straps over the hose connections and secure each strap with two setbolts and spring washers.

177. Assemble and secure the two sections of air duct on the 'B' bank side of the radiator in the manner described in Item 176.

Air cleaners

178. Fit the two air cleaner support brackets on the top of the 'A' and 'B' bank induction manifolds and secure with four setbolts and spring washers, then fit the four mounting hands to the brackets and secure them with four bolts, nuts and spring washers and eight plain washers.

179. Open up the bands on the 'B' bank side of the engine to allow the air intake necks on the air cleaners to pass through. Position the two air

cleaners with the outlet connections over the 'A' bank induction manifold and the intake hoods uppermost. Screw up the band clamping bolts finger tight.

180. Slide a hose adaptor over the turbocharger intake with the two appropriate hose clips.

181. Slide two hose connections over the branch inlets of the air cleaner-to-turbocharger duct, complete with four hose clips. Locate the duct against the air cleaners, with the lower end fitted into the hose adaptor on the turbocharger. Secure the duct to the 'A' bank support bracket with two setbolts and spring washers and slide the hoses over the connections. Tighten the six hose clips and the mounting band clamp bolts when the air cleaners and air duct are correctly positioned.

182. If necessary, fit the two air cleaner restriction indicators in their appropriate bosses.



Fig. 41 Air cleaner restriction indicator.

The engine/radiator assembly may be transported to a test bed or its normal operating position using the Lifting Beam, VP 6202. Before running the engine consult the Servicing Manual TSD 3115 for operating instructions (Chapter 2) and priming of the oil filters (Chapter 3, Section 5—Lubrication System).

SPECIAL TOOLS

Part Number	Description
VP 5641 (2)	Mounting bracket, engine to build stand.
VP 5642 (2)	Mounting bracket, engine to build stand.
VP 6815	Lifting plate, crankcase.
VP 5908	Build stand, engine.
*VP 7621/1	Lifting bracket, crankshaft (CV 2457)
*VP 7621/2	Lifting bracket, crankshaft (CV 7693).
VT 11495 (2)	Guide studs, main bearing caps.
VT 17880	Insertion tool, rear oil seal.
VT 17416 (2)	Retaining bar, cylinder liners.
VT 17877	Barring adaptor, crankshaft.
VT 14048	Guide pin, connecting rod big end.
VT 10714	Sleeve, piston rings.
VT 17845 (2)	Guide studs, wheelcase/backplate.
VT 17842	Mandrel, camshaft lead-in.
VT 10708	Insertion tool, camshaft bore cup plug.
VT 17974	Alignment tool, auxiliary drive gear.
VT 17843 (2)	Guide studs, cylinder heads.
VT 5007	Lifting bracket, cylinder head.
VT 17844 (2)	Guide studs, flywheel housing.
VP 5014	Lifting beam, flywheel housing.
VT 14040	Guide studs, flywheel.
VP 5008	Lifting bar, flywheel.
VP 4000	Test trolley, oil circuit.
VT 10723 (2)	Guide studs, sump.
VT 11685	Stud box, exhaust manifold securing.
VT 11684	Stud box, exhaust manifold coupling.
VP 5015	Lifting beam, complete engine.
VP 6202	Lifting beam, engine/radiator assembly.

*These tools are not interchangeable. Check crankshaft number before ordering.

SECTION 4—CRANKCASE AND CYLINDER LINERS

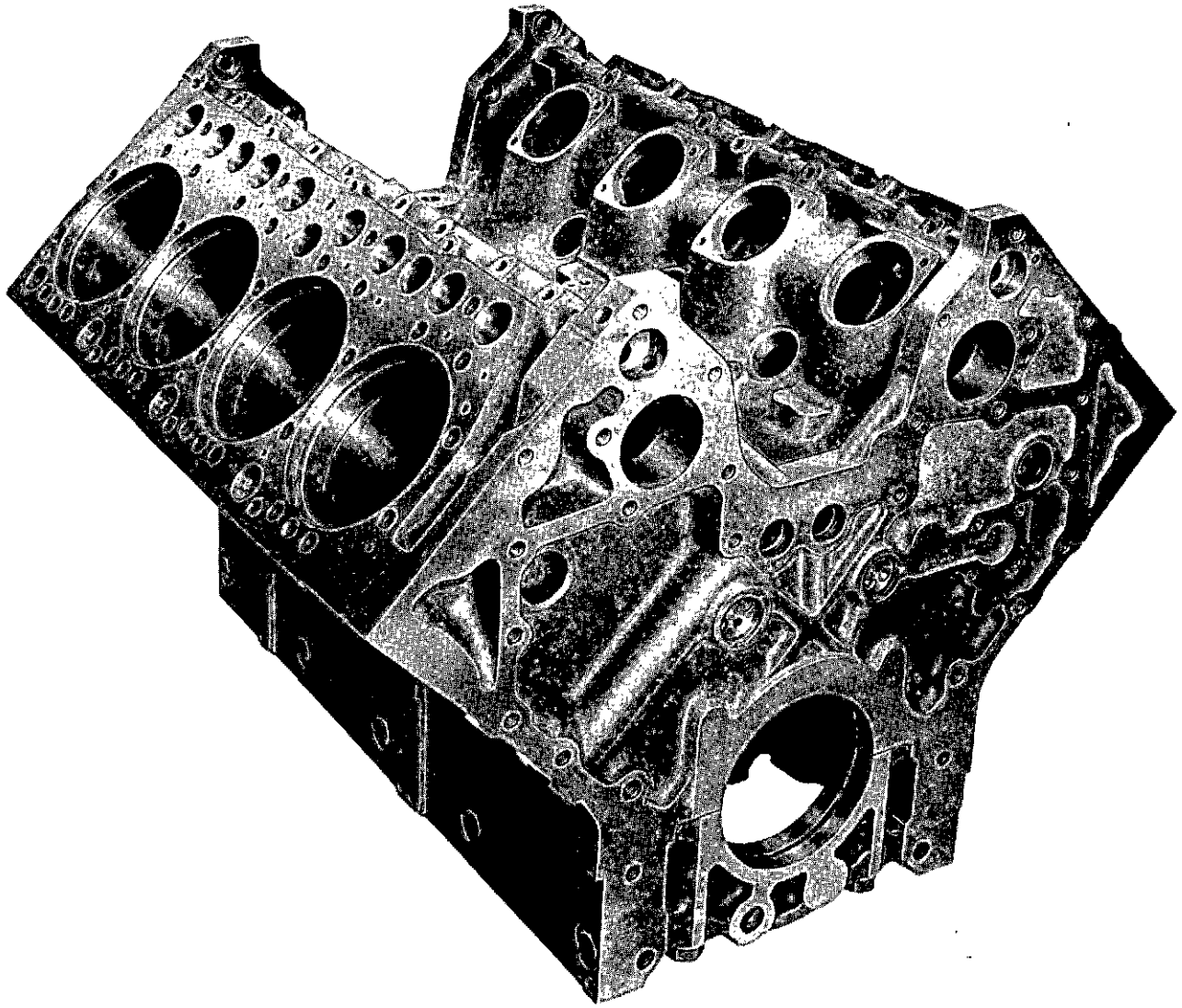

Fig. 1 Crankcase, front end view

SECTION 4—CRANKCASE AND CYLINDER LINERS

DESCRIPTION

The close grained, high duty iron crankcase is cast as a monobloc unit and dipped in a special compound to seal all non-machined faces against contamination.

The cylinder block, which forms the upper part of the crankcase, consists of two banks of four cylinders in a 90 deg. included angle 'V' configuration. The cylinder bores, arranged in a conventional staggered pattern, are machined to accept full length, slip-fit, dry liners.

Five crankshaft main bearing assemblies are secured by forged steel bearing caps, each with two bolt fixings. Two lateral securing bolts, passing through the crankcase wall into each main bearing cap, give added rigidity to the assembly.

All oilways are drilled for cleanliness and uniformity.

The eight slip-fit dry liners are flanged at the upper ends and are retained in their respective crankcase bores by the two cylinder heads. Each liner is manufactured from high quality, centrifugally cast iron, differentially hardened and pre-finished, with a fine honed oil retaining surface in the piston bore.

CRANKCASE

Cleaning and inspection

After the engine has been stripped down to the bare crankcase, carefully check all cup plugs for signs of leakage as advised in Section 2—Dismantling the engine. Remove any suspect plugs with the appropriate plug extractor and remove any traces of sealing compound from the plug bores.

Unscrew all the oilway blanking plugs and thoroughly clean out the oilways and coolant cavities, using a proprietary brand of solvent. For this purpose, Rolls-Royce recommend the use of 'Ardrox' dichloromethane based solvent and 'Diverspray' 30' inhibiting spray cleaner. These products are safe to use on all ferrous and non-ferrous metals, but it is important that the directions for use, as given at the end of Section 1—Data, should be followed.

When the crankcase is clean, check all machined faces for signs of wear or damage, particularly the liner flange seating. If any fretting has occurred, the surface may be restored by following the instructions given in S.R.S. 131. Similarly, any damage to the crankshaft bearing bores may be rectified by following the instructions given in S.R.S. 130.

Coat any new cup plugs and the oilway screwed plugs with 'Loctite' 542 and fit them into their locations, as appropriate.

CYLINDER LINERS

Cleaning and inspection

Remove any carbon build up by soaking the liner in 'Ardrox' solvent. (See Section 1—Data). Inspect the top flange for any signs of damage or fretting. If necessary, refer to S.R.S. 131 for detailed instructions.

Check each liner seating by 'blueing' the underside of the liner flange before fitting the liner into its respective bore. Using light pressure, partially rotate the liner backwards and forwards in the crankcase and check the marking left on the crankcase shoulder. The contact must show a full bedding around the circumference and at least 50 per cent across the landing width.

If the contact area on the shoulder does not meet the above requirements, the liner flange must be bedded to the shoulder using a fine grade of lapping compound. A Lapping Tool, VT 12230, is available to facilitate lapping and/or checking the bedding area.

Note: Do not lap in any liner more than is absolutely necessary to restore the seating face, as liner protrusion may be adversely affected.

The crankcase bore and cylinder liner must be scrupulously cleaned after lapping, to ensure that no harmful lapping compound enters the lubrication system via the sump.

Cylinder liner protrusion

Check the crankcase top face for cleanliness and ensure that the Protrusion Gauge, VT 14041, is clean.

Position the gauge over the liner to be measured and place the D.T.I. support stand on the gauge plate, with the D.T.I. button extension resting on the crankcase top face. Zero the D.T.I. needle and carefully re-position the support stand so that the button extension rests on the top landing of the cylinder liner. Note the reading on the D.T.I. Repeat this operation for each of the 16 positions on both cylinder banks. (See illustration).

Note: If protrusion checking is to be carried out when the crankcase is in its normal upright position, the protrusion gauge plate may be secured by inserting two of the cylinder head bolts through the holes in the plate.

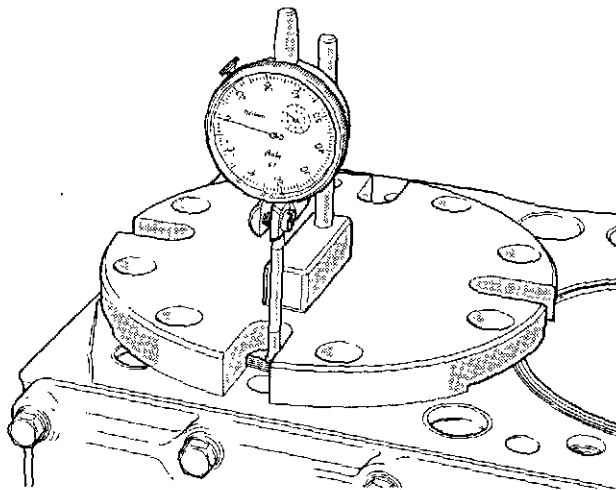

Fig. 2 Liner protrusion gauge

Important:

1. The protrusion for each liner must be between 0.076 mm and 0.127 mm (0.003 inch and 0.005 inch).
2. Variation in protrusion around the circumference of any liner must not exceed 0.025 mm (0.001 inch).
3. The difference in protrusion between the adjacent points of any two liners must not exceed 0.025 mm (0.001 inch).

Cylinder liner fitting

When fitting replacement liners, it is advisable to etch the correlation numbers on the lower section of the liner skirt.

Any bank acceptable

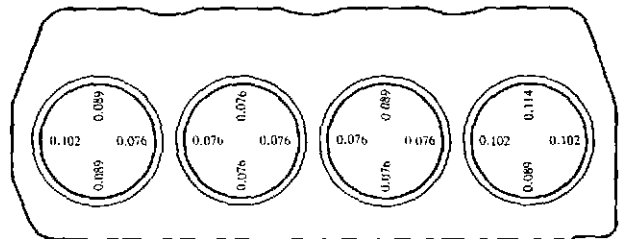

Any bank unacceptable

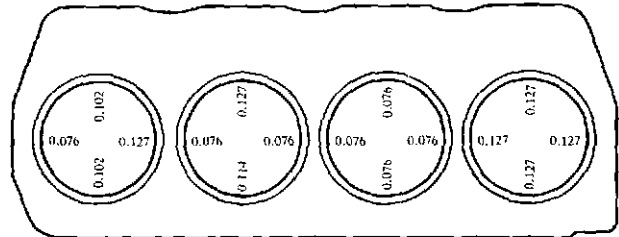

Fig. 3 Acceptable and unacceptable protrusions

After checking protrusions during engine build, a light coating of Wellseal jointing compound should be applied to the underside of each liner flange, immediately before the final fitting.

CAMSHAFT BEARINGS

The camshaft bearings, disposed singly in each camshaft bore, are steel-backed, lead-bronze rolled bushes with clinch-butt joints.

The bearings will not normally require any special treatment, other than ensuring that they are cleaned thoroughly during overall.

Damaged or worn bearings may be removed and new bearings fitted using the Insertion/extraction Tool, VT 20174, instructions for the use of which will be included in the kit.

SPECIAL TOOLS

Part No.	Description
VP 6815	Lifting plate, crankcase
VT 12230	Lapping tool, cylinder liners
VT 14041	Protrusion gauge, cylinder liners
VT 20174	Insertion/extraction tool, camshaft bearings

SERVICE RECLAMATION SCHEMES

S.R.S. 130	Reclamation main bearing bores
S.R.S. 131	Reclamation liner flange seating

**FITS AND CLEARANCES
CRANKCASE AND CYLINDER LINERS**

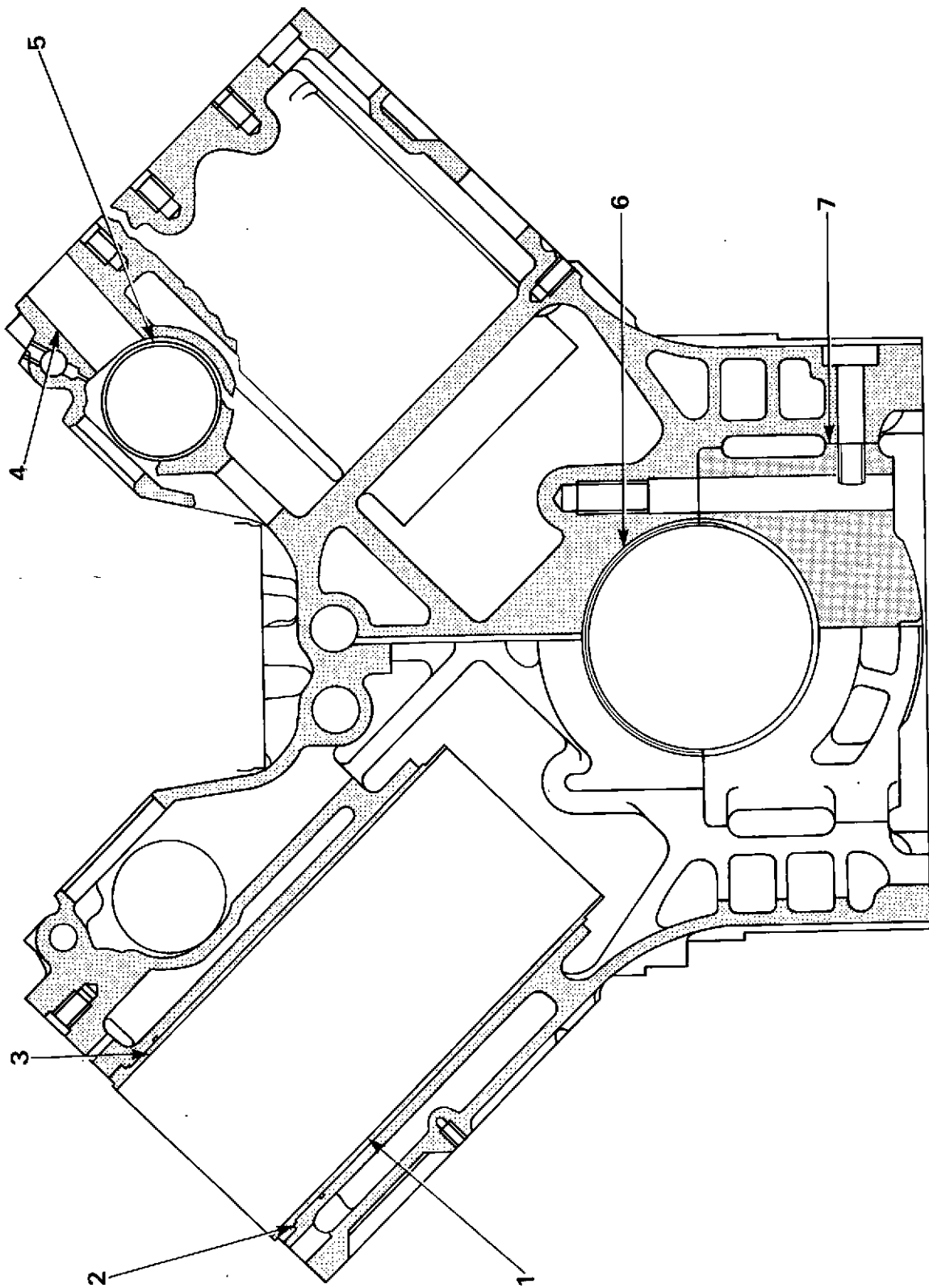

ROLLS-ROYCE DIESELS

No. ON DIAG.	DESCRIPTION	DIMENSIONS NEW		PERMISSIBLE WORN DIMENSIONS		CLEARANCE NEW		PERMISSIBLE WORN CLEARANCE		REMARKS
		mm	inch	mm	inch	mm	inch	mm	inch	
1	CYLINDER LINERS IN CRANKCASE Crankcase bore	140.488	5.531			0.013	0.0005			
		to 140.513	to 5.532			to 0.064	to 0.0025			
2	Liner skirt diameter	140.449	5.5295							
		to 140.475	to 5.5305							
3	Liner protrusion Crankcase counterbore depth (Nominal)	11.900	0.468							Liners must be fitted selectively to obtain the correct protrusion parameters.
		to 11.930	to 0.469			0.076 to 0.127	0.003 to 0.005			
4	Liner flange depth (Nominal)	12.000	0.472							
		to 12.025	to 0.473							
5	CYLINDER LINERS OUT OF CRANKCASE Liner bore	135.000	5.315	135.306	5.327					
		to 135.025	to 5.316							
6	TAPPETS IN CRANKCASE Crankcase bore	36.000	1.417			0.025	0.001	0.075	0.003	
		to 36.025	to 1.418			to 0.066	to 0.0025			
7	Tappet diameter	35.959	1.4155							
		to 35.975	to 1.416							
8	CAMSHAFT BEARINGS IN CRANKCASE Crankcase bore	71.500	2.815							
		to 71.530	to 2.816							
9	Camshaft bearing diameter	71.590	2.818							
		to 71.640	to 2.820							
10	MAIN BEARING HOUSING IN CRANKCASE Bearing housing bore	149.000	5.866							
		to 149.100	to 5.870							
11	BEARING CAPS IN CRANKCASE Bearing cap location width	236.000	9.2913							
		to 236.025	to 9.292							
12	Bearing cap width	236.000	9.2913							
		to 236.013	to 9.2918							

SECTION 5—CAMSHAFTS AND BEARINGS

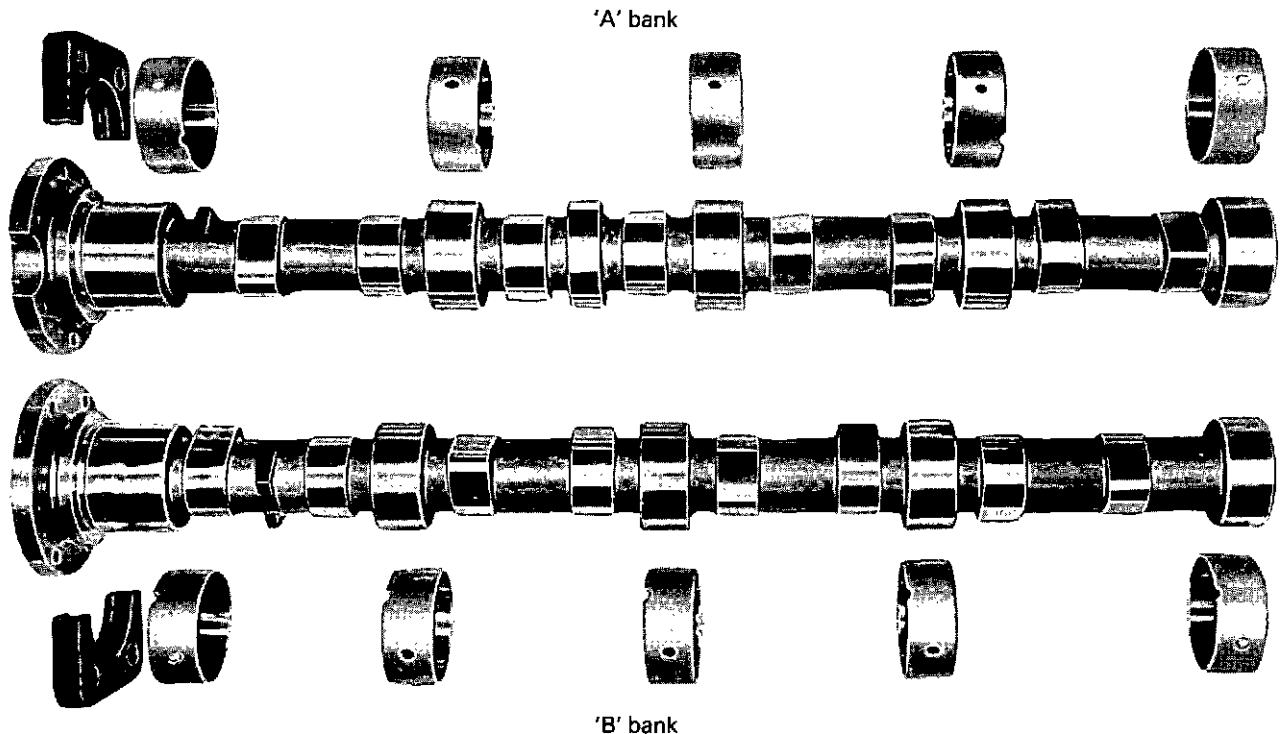

Fig. 1 Camshafts and bearings

DESCRIPTION

The two unidentical camshafts are carried in steel-backed, lead-bronze bushes, high mounted in the crankcase 'V', and driven at half engine speed from the main gear train. End float control is effected by two thrust plates, bolted to the front end of the crankcase, locating on collars machined near the front end of each shaft. The cam drive gears are secured to the camshafts each with six setbolts and one locating dowel. Timing marks on each gear ensure correct positioning with the auxiliary drive gear.

Each bearing is drilled for the supply of oil to each camshaft journal, from the appropriate auxiliary oil gallery. Small bore drillings from each gallery provide a continuous supply of oil to each cam lobe.

Removal of camshafts

If it is intended to remove one or both camshafts with the engine in its normal operating position, the radiator and numerous other components must first be removed, and provision must be made for supporting the engine beneath the front end of the sump. The recommended dismantling sequence is as follows:

1. Drain the cooling system completely.
2. Shut off the fuel supply at the tank and remove the fuel filter.
3. Remove the air cleaner duct, air cleaners and support brackets.
4. Remove the turbocharger-to-radiator duct.
5. Disconnect and remove all coolant pipework

between the thermostat, induction manifolds, coolant pump and radiator, and remove the small bore vent pipe which is clipped to the radiator top casing.

6. Remove the fan and belt guards.
7. Release the radiator stays and remove the radiator.
8. Remove the fan.
9. If fitted, remove the inertia ring from the crankshaft front end, (cruciform crankshafts only).
10. Slacken the tensioner pulley and alternator adjusting bar and remove all the driving belts.
11. Remove the tensioner pulley and the E.S.C.
12. Remove the alternator and adjusting bar.
13. Remove the engine breather pipe and fuel injector spill cross connection.
14. Remove the fan adaptor and pulley assembly.
15. Remove the crankshaft pulley and damper.
16. Remove the connecting pipe between the coolant pump and the oil-to-coolant heat exchanger.
17. Remove the coolant pump.
18. Remove the thermostat housing assembly.

Before proceeding, fit suitable packing beneath the front end of the engine sump.

Note: The packing must be carefully measured to ensure that the engine weight is equally shared by the rear engine supports and the temporary packing.

19. Remove the front engine mounting and radiator support.
20. Remove the wheelcase.

If it is intended to remove one camshaft only, some of the following instructions will refer to the bank in question.

21. Remove the exhaust manifold as necessary.
22. Remove the high pressure, low pressure and fuel spill pipework where applicable.
23. Remove the fuel filter header bracket. ('A' bank only).
24. Disconnect the speed control. ('A' bank only).
25. Disconnect and remove the stop solenoid, complete with its mounting plate. ('B' bank only).

26. Remove the fuel feed pump and access plate. ('A' bank only).
27. Remove the exhaust elbow. ('B' bank only).
28. Remove the induction manifold as necessary.
29. Remove the appropriate rocker box and withdraw the pushrods.
30. Remove the cylinder head and withdraw the tappets.
31. Disconnect the fuel pump drive and remove the auxiliary drive gear assembly.
32. Remove the gear ring from the end of the camshaft, as necessary.
33. Measure and record the end float of the camshaft.
34. Unscrew the thrust plate securing screws and remove the thrust plate.
35. Remove the access plates from the crankcase 'V' as necessary.
36. Carefully guide the camshaft out of the bearings.

INSPECTION

Thoroughly clean the camshaft, then subject the shaft to a crack test preferably by the electro-magnetic method.

Inspect the cams and journals for wear and damage. Slight score marks may be removed with an oil stone, provided that the cam profile is unaffected. Excessively worn camshafts must be renewed.

Crack test the gear ring and inspect the teeth for wear and damage.

Check the thrust plate for wear and damage and renew the plate if the end float, before removal, exceeds 0.55 mm (0.022 inch).

Inspect the tappets for wear and damage and check the clearance of each tappet in its housing. (See Section 4. FITS AND CLEARANCES).

CAMSHAFT BEARINGS

As stated in Section 4—CRANKCASE AND CYLINDER LINERS, the camshaft bearings will not normally require any special treatment other than thorough cleaning. Renewal of any damaged bearings will normally be carried out when the crankcase has been stripped to the bare state as described in Section 2.

Inspect each bearing for wear and damage especially score marks caused during camshaft withdrawal. Clean up any slight marks and check the camshaft running clearances. Renew any bearing which exceeds the limits given at the end of the Section. A combined insertion/extraction tool is available for this purpose, instructions for the use of which, are included in the kit.

CAMSHAFTS—FITTING

Check that the bearing oilways are clean and free of restrictions. Oil the bearings and carefully guide the camshaft into position in the crankcase. Before the camshaft is fully home, prepare the thrust plate by coating the contact faces of the groove with anti-scuffing compound such as 'Molyslip' and coat the countersunk faces of the securing screws with anti-seize compound such as Rocol' J166.

Slip the thrust plate into position around the camshaft collar and secure it to the crankcase with the two countersunk setscrews. Torque tighten the screws to 70 Nm (52 lbf. ft.).

Check that the camshaft rotates freely and measure

the end float. Limits on new assemblies are 0.100 mm to 0.550 mm (0.004 inch to 0.021 inch).

Fit the drive gear ring to the camshaft flange and tap in the locating dowel. Coat the thread of the six setbolts with 'Studlock' 270, fit the bolts, with plain washers, and torque tighten to 40 Nm (30 lbf. ft.).

Inspect the auxiliary drive oil seal for serviceability and fit the assembly to the backplate, ensuring that the timing marks on the camshaft gears, main idler gear and auxiliary drive gear are correctly in mesh. See Section 3 for details.

Connect the fuel pump drive coupling, ensuring that the timing marks are correctly positioned, (see Section 3), and tighten the yoke nuts and the spring drive coupling nuts to the correct torque figure, (see Date Section).

Refit the rest of the engine components in the reverse order to the dismantling sequence, renewing all gaskets and checking the fits and clearances where applicable.

SPECIAL TOOLS

As required for engine assembly/dismantling. See relevant Sections.

**FITS AND CLEARANCES
CAMSHAFTS AND BEARINGS**

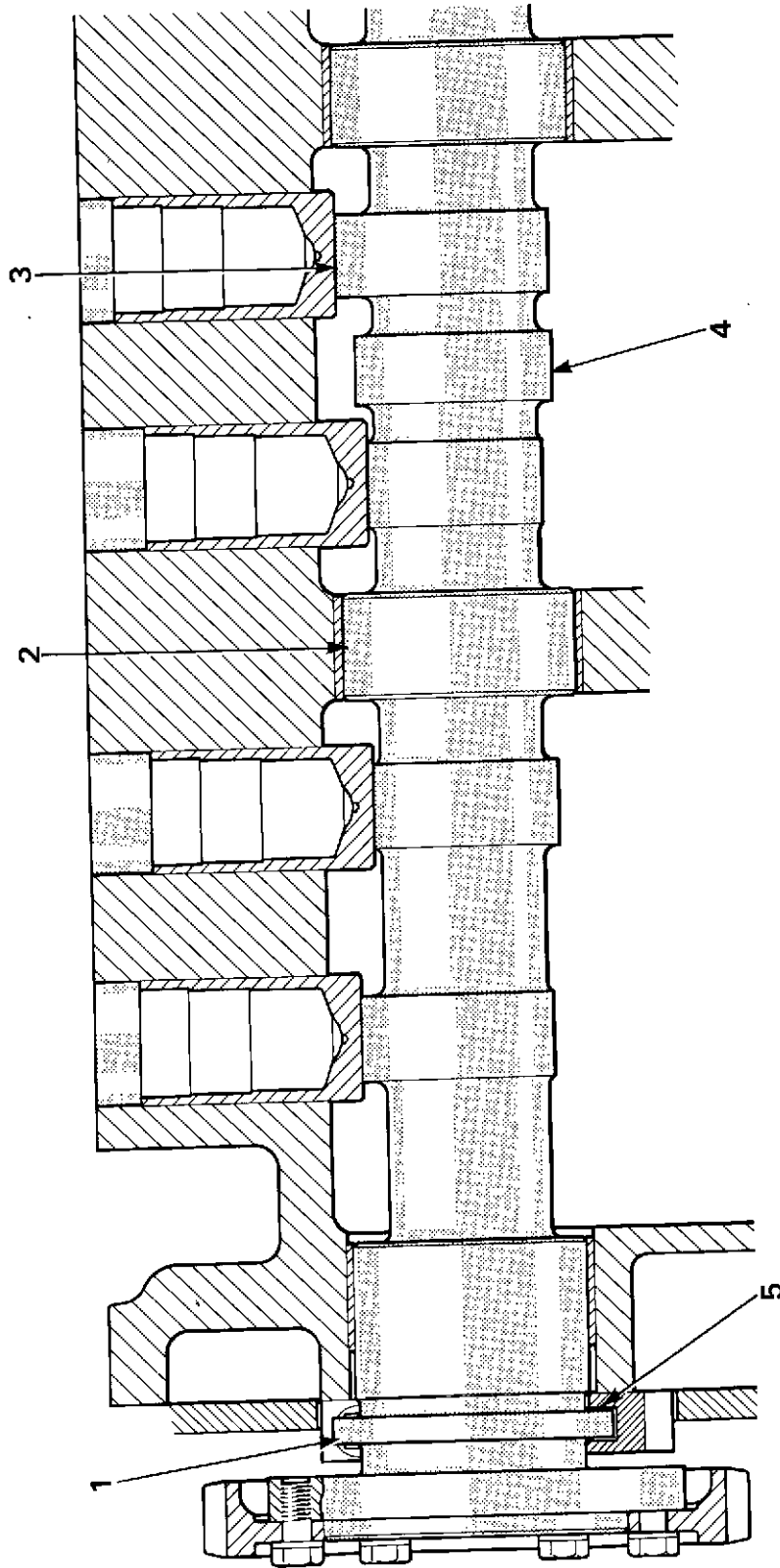

ROLLS-ROYCE DIESELS

No. ON DIAG.	DESCRIPTION	DIMENSIONS NEW		PERMISSIBLE WORN DIMENSIONS		CLEARANCE NEW		PERMISSIBLE WORN CLEARANCE		REMARKS
		mm	inch	mm	inch	mm	inch	mm	inch	
1	CAMSHAFT AND BEARINGS Camshaft end float					0.100 to 0.550	0.004 to 0.022	0.550	0.022	End float must be maintained within these limits. See also Item 5.
2	Camshaft in bearings Bearings - bore	67.577 to 67.602	2.660 to 2.661			0.077 to 0.121	0.003 to 0.005	0.25	0.010	
	Camshaft journals - diam.	67.481 to 67.500	2.656 to 2.657							
3	CAMS Cam lift Inlet cams	8.247 to 8.497	0.3246 to 0.3345	7.798	0.307					
	Exhaust cams	8.34 to 8.59	0.328 to 0.338	7.874	0.310					
4	FUEL FEED PUMP DRIVE Ellipse radii	29.0 and 33.0	1.142 and 1.299							
	Cam lift	4.0	0.157	3.365	0.132					
5	THRUST PLATES Groove width at thrust faces	8.05 to 8.25	0.317 to 0.325	8.25	0.325					

SECTION 6—CRANKSHAFT, MAIN BEARINGS AND FLYWHEEL

Description

A five bearing, chrome molybdenum, forged steel crankshaft is fitted to the CV8 engine. The crankshaft may be one of two designs namely, Paired Throw or Cruciform. The type of shaft fitted to a particular engine may be ascertained by the number stamped or cast on to the front crank web. If, for any reason, the crankshaft has to be renewed, it is important to order the correct Part Number, as Cruciform and Paired Throw crankshafts are not interchangeable unless the camshafts and fuel injection pump are renewed also.

The main bearings are steel backed, lead bronze half shell type with lead indium flashing on the running faces. Lubrication for the bearing surfaces is provided from the main oil gallery drillings.

Thrust washers, located on either side of the centre main bearing housing, control the crankshaft end float.

The flywheel, secured to the crankshaft rear end face with 16 socket capscrews, is located by means of a single dowel. Timing marks on the flywheel periphery can be observed through an aperture in the flywheel housing. A starter gear ring is shrunk on to the front edge of the flywheel.

Removal

Details given below are, in general, a reversal of parts of the sequence given in Section 3—ASSEMBLING THE ENGINE.

1. Drain the lubrication and cooling systems completely and remove the fuel and lubricating oil filter canisters.
2. Disconnect and remove the oil-to-coolant heat exchanger and the starter motor.
3. Fit the transportation feet or other suitable engine supports and remove the radiator and associated pipework, followed by the fan, drive belts and crankshaft front end attachments. Fit the barring device to the crankshaft front end.
4. Remove the wheelcase.
5. Remove the air cleaners and ducting.
6. Using the Lifting Beam, VP 5015, lift the engine, remove the transportation feet and fit the engine into a turnover build stand.
7. Remove the timing cover from the flywheel housing and unscrew the timing pointer.
8. Using the guide studs and lifting bar, remove the flywheel and clamping ring.
9. Using the guide studs and lifting beam, remove the flywheel housing, followed by the oil seal housing.
10. Turn the engine over and remove the sump followed by the oil pump assembly and baffle plate.
11. Remove the oil pump idler gear and axle from the front main bearing cap.

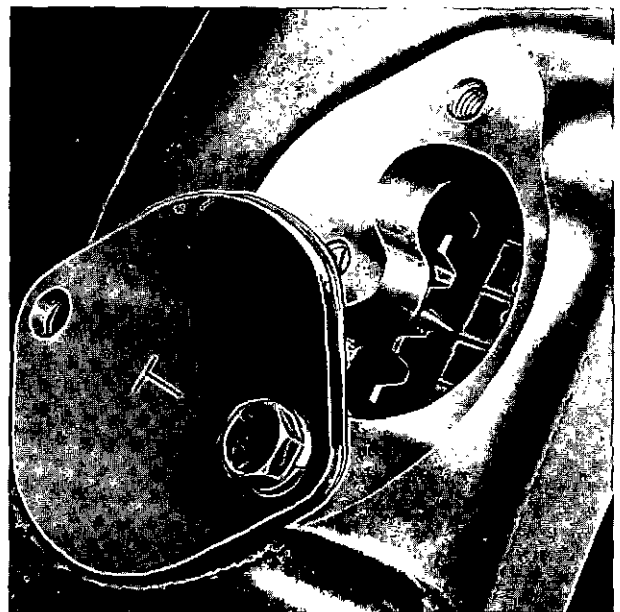

Fig. 1 Flywheel timing pointer.

Turn the engine in the build stand, to a suitable angle to enable the connecting rod big end bearings to be removed.

12. Remove the nuts from the connecting rod big end bolts, lift off the bearing cap and remove the lower bearing shell. Using the guide pin, gently push the piston/connecting rod assembly clear of the crankshaft and lift out the upper bearing shell.

Caution: Do not push the piston/connecting rod assembly far enough to make contact between the piston crown and the valve heads.

When the crankshaft is turned to gain access to each big end bearing, great care must be taken to ensure that the crankpins do not foul the bolts of previously removed bearings.

13. Remove the ten lateral setbolts and washers from the crankcase side walls.

14. In turn, remove the setbolts from each main bearing cap and, using the guide studs and extractor remove the cap. Lift out the lower bearing shell from each cap. Remove the thrust washers with the centre main bearing cap.

When all the main bearing caps have been removed, lift out the crankshaft, using the appropriate lifting bracket, and remove the upper bearing shells.

CRANKSHAFT

Dismantling and cleaning

Screw the extractor into the tapped hole in each sludge plug, press the plug inwards and release the spring retaining ring. Withdraw each plug and clean the components in a non-caustic cleaning solution.

Wash out the crankshaft oilways and sludge traps with paraffin and blow through with compressed air.

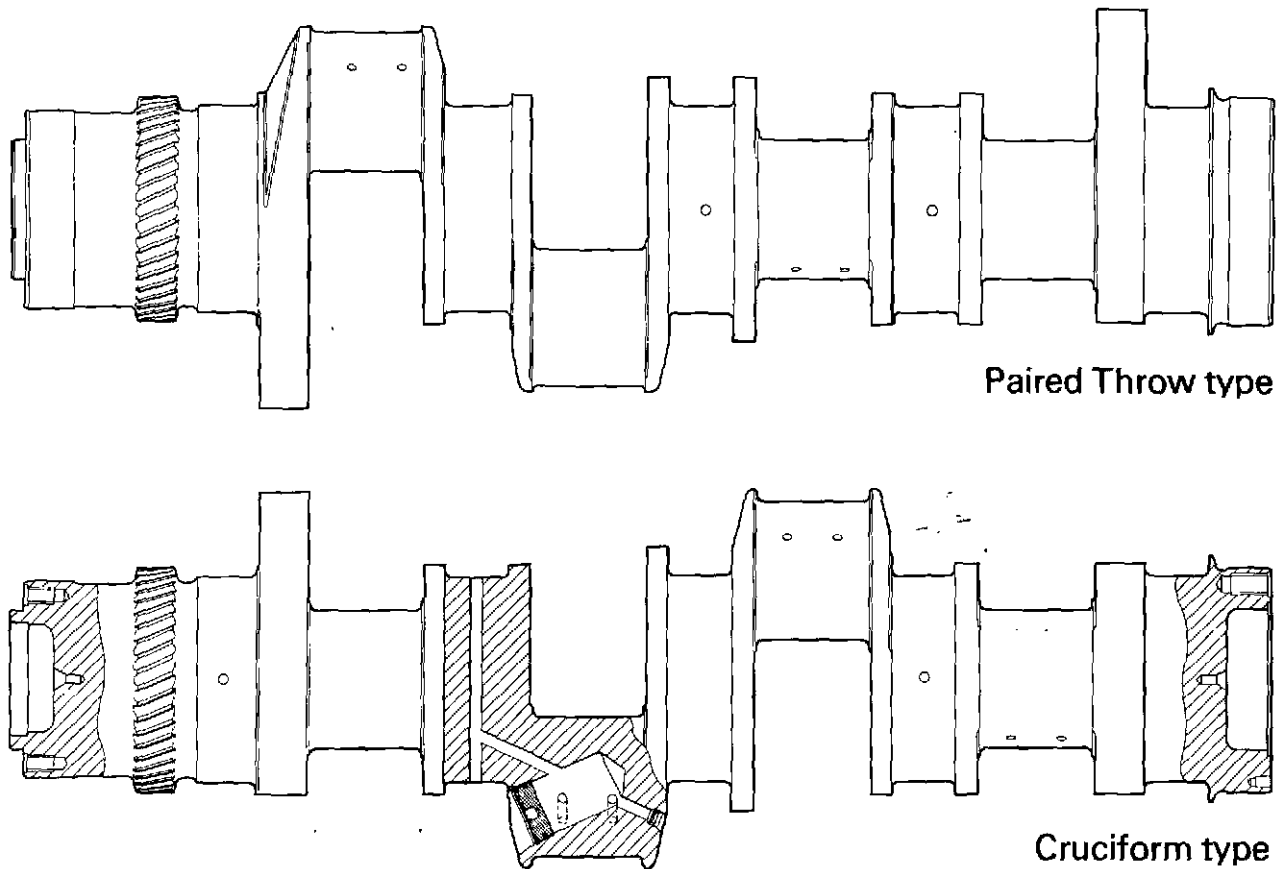

Fig. 2 Crankshaft

Ensure that the crankshaft is thoroughly cleaned then subject it to a crack test, preferably by the electro-magnetic method.

Inspection

Examine the main journals and crankpins for wear and score marks and check for ovality. Check the two thrust faces for score marks. For reclamation of damaged or worn journals and crankpins, see S.R.S. 121 Issue 2.

Support the shaft at each end, by means of 'V' blocks beneath the front and rear main journals. Measure the amount of 'bow' at the centre main journal. The permissible bow must be progressive, along the length of the shaft.

Check the front and rear end faces for damage and check for score marks on the balance weight and flywheel circumferential locations.

Providing that the shaft is serviceable, slight scoring on the journals, crankpins, thrust faces and end locations may be polished out using a very fine grade of oil stone.

MAIN BEARINGS

Inspection

Check the bearing shells for wear, cracks and embedded foreign material. Renew any bearing shells in sets, if there is the slightest doubt that the bearing will not complete a further full period of service.

Thrust washers

Check the thickness of the thrust washers. Nominal new dimensions are: 2.93 to 3.0 mm (0.116 to 0.118 inch). If excessive wear is apparent on the thrust faces, when checked in conjunction with the crankshaft end float, new thrust washers must be fitted.

FLYWHEEL

Inspection

Check the bolt and dowel holes for elongation and examine the contact face for signs of fretting.

Check the teeth of the starter ring for wear and damage. If excessively worn or damaged, the ring

should be renewed as follows:

1. Place the flywheel assembly horizontally on a drill table and drill holes through the ring body in diametrically opposite positions, until the ring is weakened sufficiently to be driven off. Do not attempt to drill holes through the flame hardened teeth. Take care not to damage the flywheel during any of the preceeding operations.
2. Check the flywheel and the new starter ring for burrs. Ensure that both components are clean.
3. Heat the ring evenly to 200 deg. C., fit the ring on to the flywheel location and rotate it to ensure correct seating.

Important: Ensure that the chamfered edge of the teeth face away from the flywheel.

4. Allow the ring to cool naturally, then check by feeler gauge that the ring is tight against the shoulder of the flywheel.

ASSEMBLY

Fit new 'O' ring seals to each of the sludge plugs. Coat each plug and housing with clean engine oil and using the extraction/insertion tool, push each plug into the crankshaft housing. Insert the spring retaining ring then pull the plug back against it.

Fit the main bearings as described in Section 3—ASSEMBLING THE ENGINE, and carefully lower the shaft into position.

Caution: Extra care must be taken when fitting the crankshaft if the piston/connecting rod assemblies and gear train have not previously been removed.

Ensure that the big end bolts do not foul the crankpins and that the crankshaft gear timing marks are correctly positioned, relative to the main idler gear.

Fit the thrust washers and main bearing caps as described in Section 3, and check the crankshaft end float.

Refit the previously removed components, using new gaskets, oil seals and washers where advised in the relevant Sections of the Manual.

SPECIAL TOOLS

Part No.	Description
VT 17877	Barring adaptor, crankshaft.
VT 17845	Guide studs, wheelcase.
VT 5015	Lifting beam, engine.
VP 5908	Build stand, engine.
VT 14040	Guide studs, flywheel.
VP 5008	Lifting bar, flywheel.
VT 17844	Guide studs, flywheel housing.
VP 5014	Lifting beam, flywheel housing.
VT 14048	Guide pin, connecting rod big end.
VT 11495	Guide studs, main bearing cap.
VT 11671	Extractor, main bearing cap.
VP 7621/1	Lifting bracket, crankshaft (Paired Throw Type).
or VP 7621/2	Lifting bracket, crankshaft (Cruciform Type).
VT 10706	Insertion/extraction tool, sludge plugs.

SERVICE RECLAMTION SCHEMES

S.R.S. 121 Issue 2. Reclamation of crankshaft journals and crankpins.

**FITS AND CLEARANCES
CRANKSHAFT, MAIN BEARINGS AND FLYWHEEL**

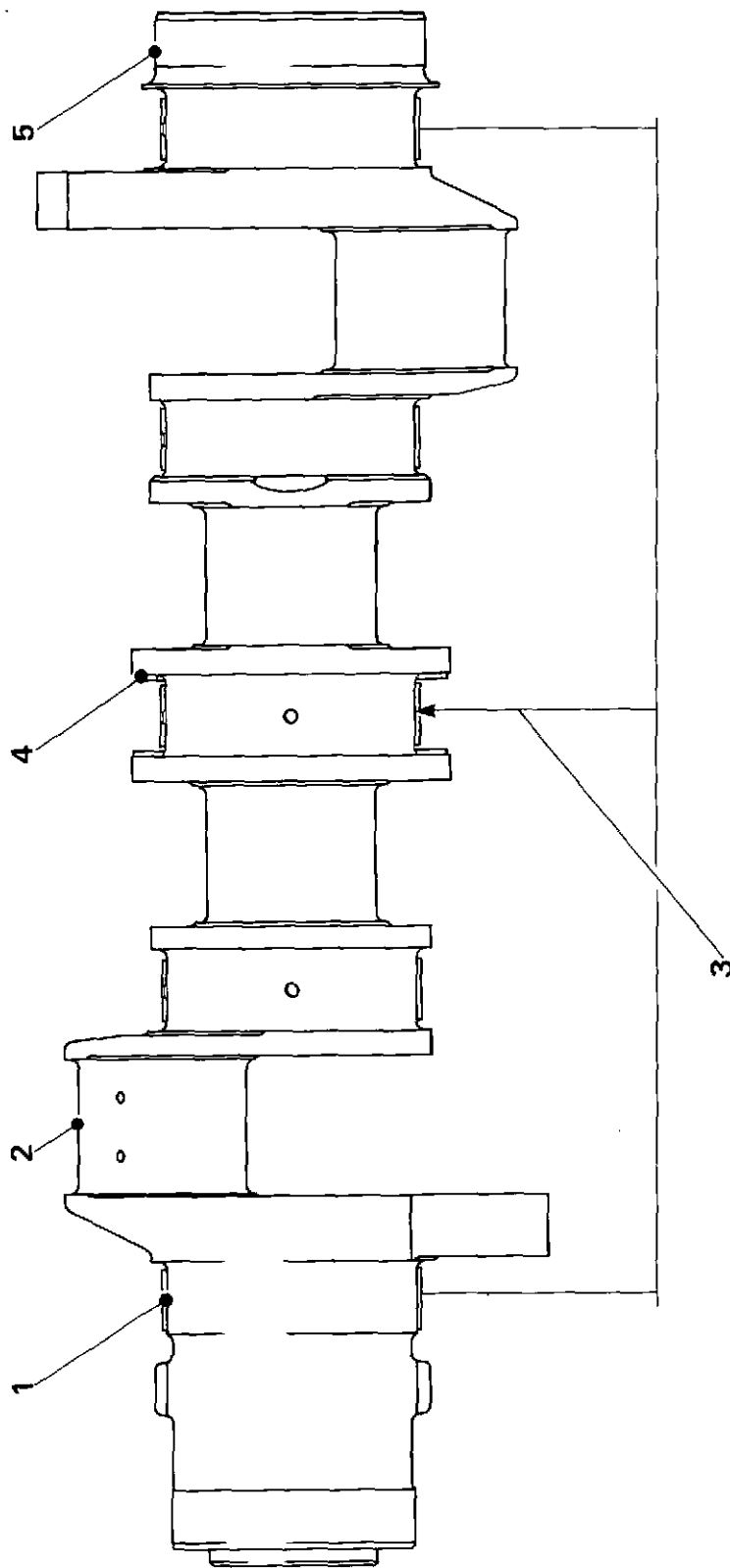

No. ON DIAG.	DESCRIPTION	DIMENSIONS NEW		PERMISSIBLE WORN DIMENSIONS		CLEARANCE NEW		PERMISSIBLE WORN CLEARANCE		REMARKS
		mm	inch	mm	inch	mm	inch	mm	inch	
1	CRANKSHAFT JOURNALS Diameter	145.975	5.747	145.910	5.7445					S.R.S. 121 Issue 2 (See text)
		to 146.000	to 5.748	0.076	0.003	0.076 to 0.145	0.003 to 0.0057			
2	Ovality Journals in main bearings Running clearance									S.R.S. 121 Issue 2 (See text)
3	CRANKPINS Diameter	97.978	3.8573	97.9145	3.8548					S.R.S. 121 Issue 2 (See text)
		to 98.000	to 3.8582	0.076	0.003					
4	Ovality CRANKSHAFT BOW Bow at centre journal when supported by 'V' blocks under No.s 1 and 5 journals.									The bowing must be progressive, reading from the outer main to the centre main journal.
5	CRANKSHAFT END FLOAT Centre journal	46.50	1.8307	46.55	1.8326					
		to 46.25	to 1.8208	0.10 to 0.30	0.004 to 0.012	0.483	0.019			
6	Width between crankwebs Centre bearing Width over thrust washers	46.40	1.8267							
7	FLYWHEEL ON CRANKSHAFT Flywheel bore	160.0	6.2992	160.025	6.3002					
		to 159.961	to 6.2976	0.014 to 0.064	0.0006 to 0.0026					
8	Crankshaft diameter	159.986	6.2986							

SECTION 7—PISTONS AND CONNECTING RODS

DESCRIPTION

Pistons

The pistons, cast from high silicon aluminium alloy, have open toroidal combustion chambers machined into their crowns.

Three compression rings and one oil control ring are carried in machined grooves around each piston wall, the top ring being carried in an austenitic iron insert to reduce wear. All the rings are fitted above the gudgeon pin.

The ring type and position is as follows:

- Top ring—Inlaid molybdenum surface
- Second ring—Chrome plated
- Third ring—Ferrox treated surface
- Bottom ring—Composite chrome plated oil control

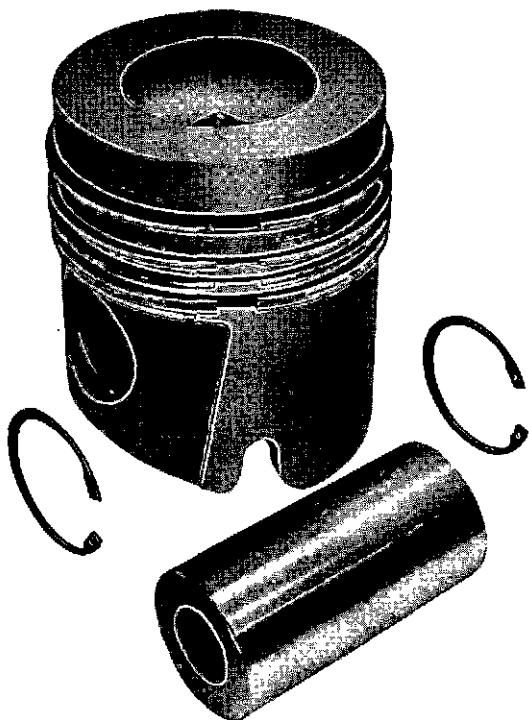

Fig. 1 Piston assembly

Each piston is tin plated on all surfaces apart from the gudgeon pin bore.

The fully floating gudgeon pin is retained by circlips carried in machine grooves in the gudgeon pin bore.

Connecting rods

The connecting rods are chrome-molybdenum steel forgings with pressed in steel backed, lead-bronze small end bushes. The big end bearings are of conventional design in that renewable steel-backed, lead-bronze half shells are used. The shells, as with the main bearings, have lead indium flashed running faces.

Positioning of the bearing shells is provided by machined grooves in the steel shells locating on shoulders around the centre of each big end bolt.

A hole bored centrally through the column of each rod allows pressurised oil to be directed, intermittently, from the crankpin to the small end bush.

Markings on each connecting rod assembly provide rod to cap correlation and cylinder bore number.

Each connecting rod, complete with small end bush and big end bolts and nuts, is weighed during manufacture and stamped with a group letter. All rods having the same group letter fall within a weight range of 0.980N (0.22 lbf). If for any reason a connecting rod has to be renewed, it is important that the replacement rod should be of the same group as the original.

Weight groups are as follows:

- Y—40.697N to 41.678N (9.149 lbf to 9.369 lbf)
- Z—41.678N to 42.659N (9.369 lbf to 9.590 lbf)
- A—42.659N to 43.639N (9.590 lbf to 9.810 lbf)
- B—43.639N to 44.620N (9.810 lbf to 10.031 lbf)
- C—44.620N to 45.600N (10.031 lbf to 10.251 lbf)
- D—45.600N to 46.581N (10.251 lbf to 10.472 lbf)
- E—46.581N to 47.562N (10.472 lbf to 10.692 lbf)

PISTON AND CONNECTING ROD REMOVAL

1. Drain the coolant to a level below the outer edge of the cylinder head.
2. Drain the lubricating oil from the sump.

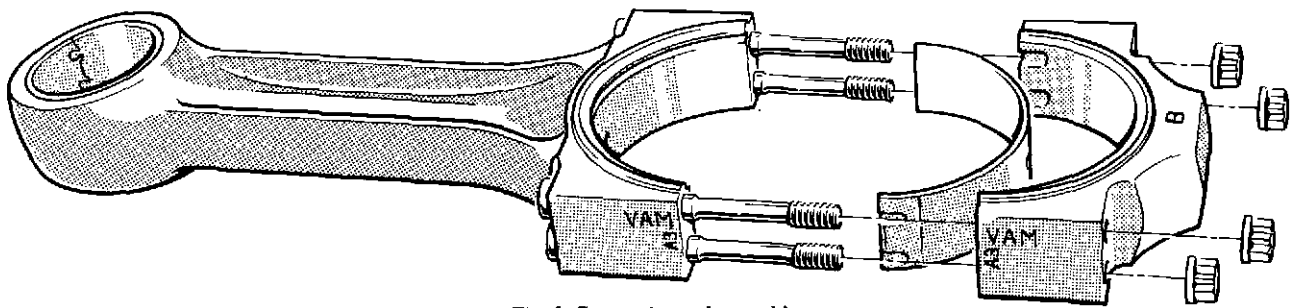

Fig. 2 Connecting rod assembly

3. Remove the sump.
4. Remove the lubricating oil pump and oil baffle.
5. Remove the cylinder head as necessary (see Section 8) and fit the liner retaining bars, VT 17416.
6. Turn the crankshaft until the piston to be removed is at B.D.C.
7. Remove the four big end nuts and withdraw the bearing cap and lower shell.
8. Fit the connecting rod Guide Pin, VT 14048, to a big end bolt and push the assembly out through the top of the cylinder.

Keep each piston/connecting rod assembly together.

Dismantling

1. Using the piston Ring PLiers, VT 17022, carefully remove each ring and lift out the backing spring from the oil control ring groove.
2. Remove the gudgeon pin circlips using a pair of Seegar pliers.
3. Heat the piston by immersing it in hot water, and

push out the gudgeon pin to release the connecting rod.

CLEANING AND INSPECTION

Pistons and rings

Decarbonize the components, preferably by soaking in a proprietary solvent such as 'Maxan' or 'Ardrox' 667.

Inspect the piston for wear and score marks and check that the ring grooves are not worn beyond the permissible limits. Check the grooves, if necessary, using new piston rings.

Crack-test the gudgeon pin and check its fit in the piston. The gudgeon pin should be a push-fit at 20 deg. C. (68 deg. F). If the pin is loose, the assembly must be rejected.

Any piston/gudgeon pin assembly not conforming to the dimensions given at the end of this Section must be renewed.

Inspect the piston rings for score marks, wear and signs of leakage. Discard the top ring if the surface finish shows large pores or voids or if the surface is breaking up. Compare the surface with that on a new ring if necessary.

Inspect the spring behind the oil control ring. If there is any appreciable shortening of the spring over its circumferential length, the spring and oil control ring must be renewed together.

Check the gap of each ring in a new liner or in an unworn portion of the original liner. Discard any ring having a gap in excess of the limits given at the end of the Section.

Notes:

- (a) Where a new liner has been fitted, the piston rings must also be renewed.
- (b) When a new piston ring is fitted into an original liner, the glaze in the liner bore must be broken by lapping or honing.

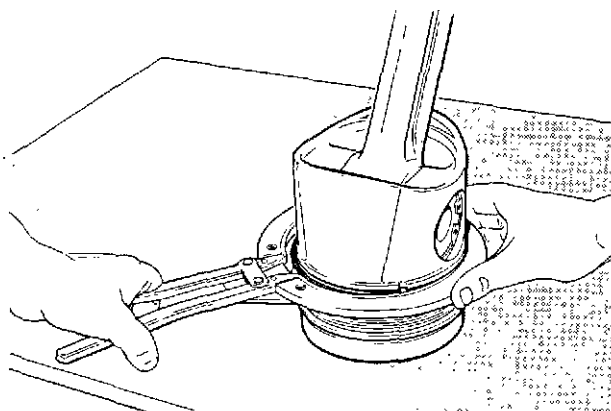

Fig. 3 Fitting removing piston rings

Connecting rods and bearings

Clean the connecting rod assembly in paraffin or a degreasing solvent and subject the rod, bearing cap and big end bolts to a crack test.

Inspect the bolts for stretching and signs of damage; renew any bolts which appear suspect.

Note: When refitting the big end bolts ensure that the flat, machined on the central shoulder of each bolt, faces away from the big end bore, otherwise positive location of the bearing shells will not be possible. Replacement bolts do not have flats machined on the central shoulders and require no special fitting instructions.

Check the small end bush for wear and score marks. If any bush is badly scored it must be renewed as described. See below.

Inspect the big end bearing shells for cracks, score marks, wear and embedded foreign material. Renew the shells in pairs if there is any doubt that they may not complete a full period of service.

Check the big and small end alignment of the rod, in two planes. Do not attempt to correct a bent or twisted connecting rod.

SMALL END BUSH RENEWAL

1. Using the Removal Tool, VT 11733, and hand press, drive out the unserviceable small end bush. Clean up any burrs from the small end eye of the rod and ensure that the oilway is clear.

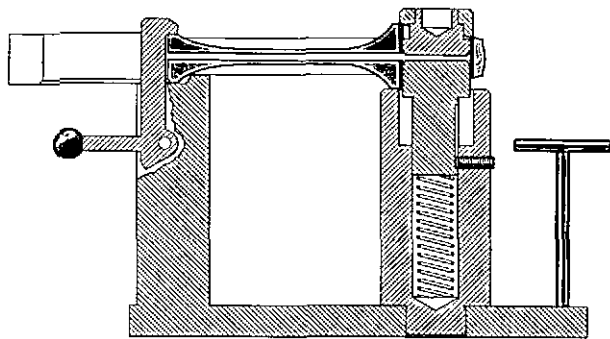

Fig. 4 Bush removal tool

2. Position the connecting rod on the Insertion Tool, VT 12920, locate the new small end bush on the pressing tool and, using a hand press, press the bush into the connecting rod, until the pressing

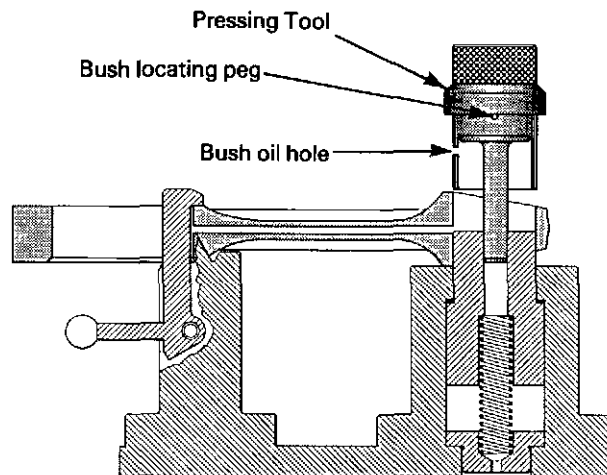

Fig. 5 Bush insertion tool

tool flange contacts the side face of the connecting rod small end.

3. Cut off the protruding edges of the small end bush and dress up with a smooth file until flush with the angles faces of the connecting rod.
4. Secure the connecting rod to a boring machine and bore out the bush to the correct diameter, (see 'FITS AND CLEARANCES' at the end of this Section).

ASSEMBLING PISTON AND CONNECTING ROD

Before assembling, check the connecting rod oilway for dirt or swarf and blow through with a jet of compressed air.

1. Immerse the piston in hot water, dry the gudgeon pin bore using a lint free cloth and fit one circlip into its groove.
2. Apply a coating of clean engine lubricating oil to the small end bush, the gudgeon pin and the gudgeon pin bore.
3. Position the connecting rod small end in the piston, ensuring that the cut out in the piston skirt is on the opposite side to the chamfered rim of the big end bearing bore.
4. Slide the gudgeon pin into position through the small end bush and fit the remaining circlip into its groove.

Stand the assembly on the piston crown and carefully fit the piston rings into their grooves in the sequence given at the beginning of this Section.

Notes:

- (a) Ensure that the non-reversible rings are fitted the right way up.
- (b) The backing spring of the oil control ring must be opened up and fitted around its ring groove before fitting the ring to the piston.

Before fitting the piston/connecting rod assembly to the engine, the ring gaps must be staggered as shown in the illustration.

Fit the assembly to the engine as described in Section 3 and rebuild the engine using new joint gaskets where applicable.

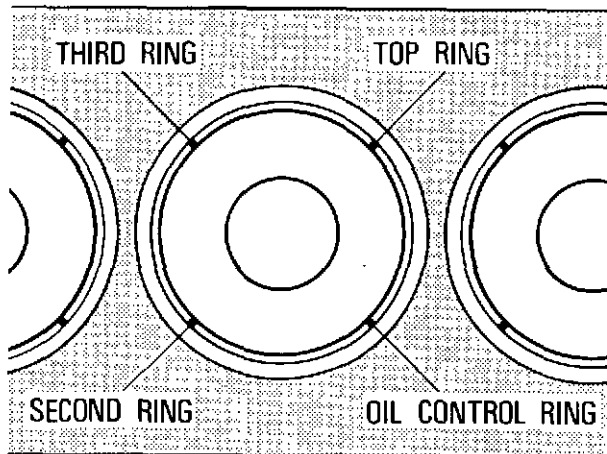

Fig. 6 Ring gap positioning

NEW PISTONS

If, at any time, it is found necessary to renew a piston, the replacement piston must be checked to ensure that the correct clearance between the cylinder head flame face and the piston crown is maintained. A Piston Height Checking Fixture, VT 18033, is available for this purpose, (see illustration).

To check the piston height, place the slider/ring assembly on top of the setting piece and adjust the D.T.I. gauge on its stand until the needle reads zero. Without disturbing the D.T.I. remove the setting assembly and rest the slider, in its supporting ring, on the gudgeon pin. Carefully slide the piston beneath the D.T.I. gauge, as shown, and note the gauge reading.

Machine the excess material from the piston crown on a milling machine. A Holding Fixture, VT 18036, Milling Cutter, VT 18035, and Facing Tool, VT 18297, are available for this purpose.

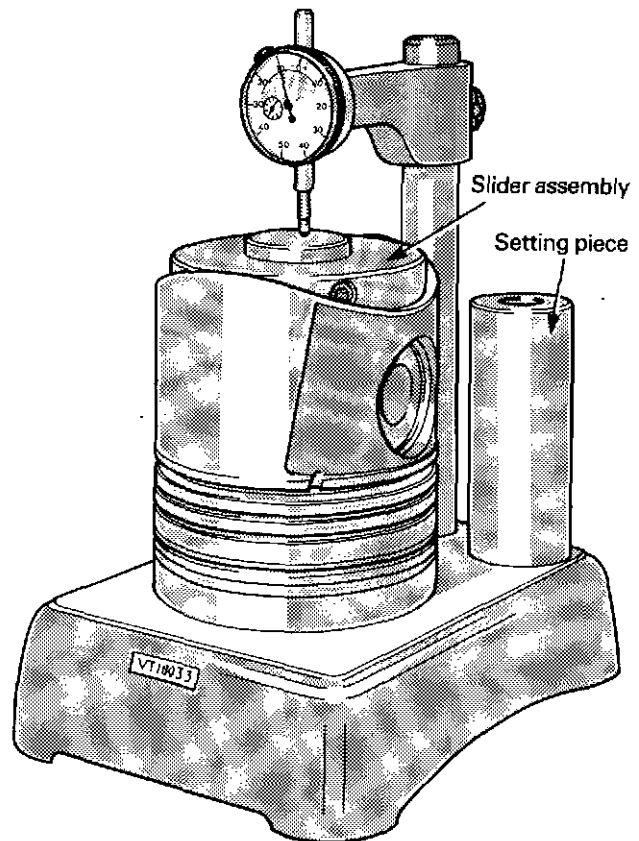
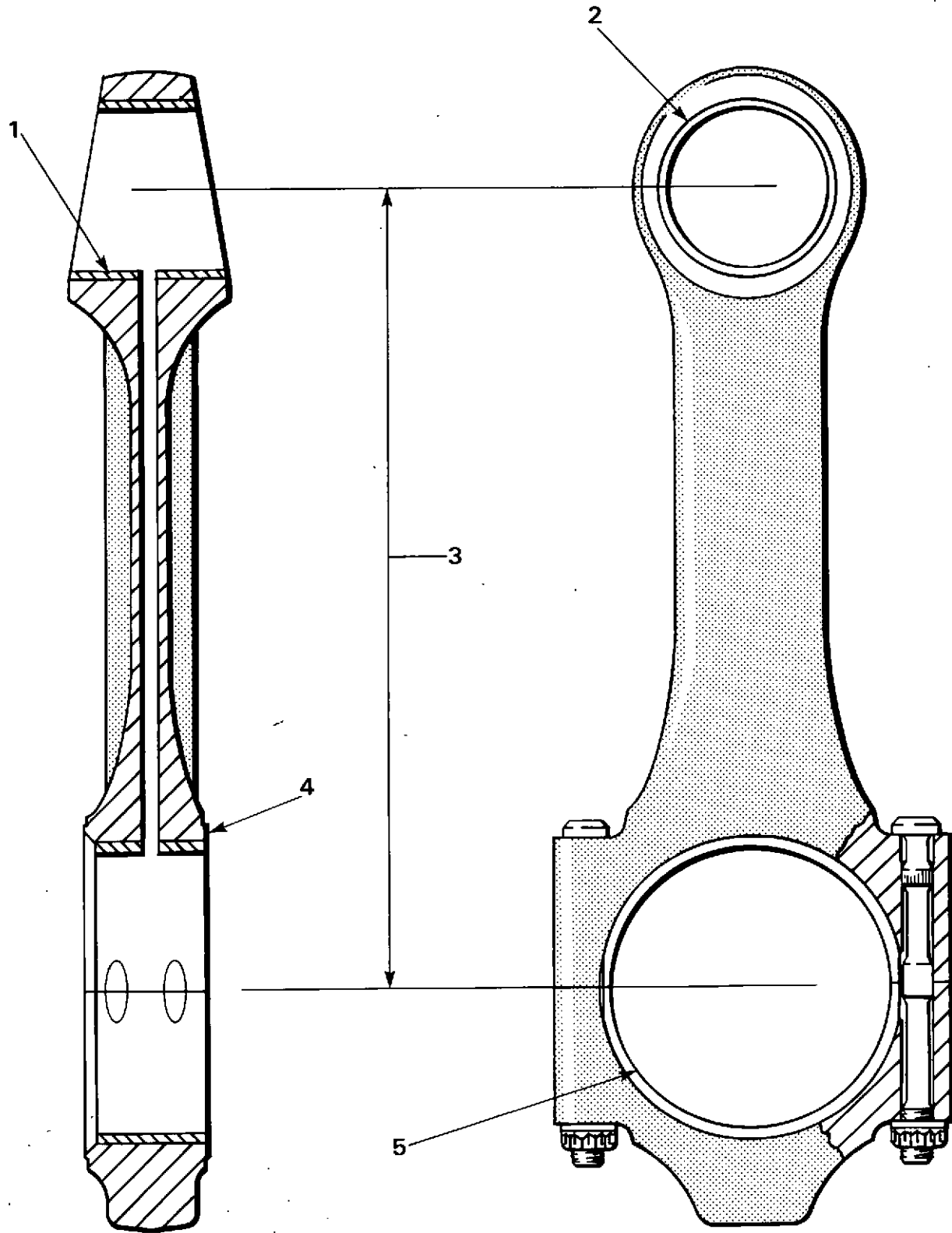

Fig. 7 Piston height checking fixture

SPECIAL TOOLS

- | | |
|------------|---|
| VT 5007 | Lifting bracket, cylinder head (horizontal) |
| or VT 7692 | Lifting bracket, cylinder head (at 45 deg.) |
| VT 17416 | Retaining bars, cylinder liners |
| VT 17022 | Pliers, piston ring |
| VT 11733 | Removal tool, connecting rod small end bush |
| VT 12920 | Insertion tool, connecting rod small end bush |
| VT 18033 | Checking fixture, piston height |
| VT 18036 | Holding fixture, piston machining |
| VT 18035 | Milling Cutter, piston crown |
| VT 18297 | Facing tool, piston crown |

**FITS AND CLEARANCES
PISTONS AND CONNECTING RODS**



ROLLS-ROYCE DIESELS

No. ON DIAG.	DESCRIPTION	DIMENSIONS NEW		PERMISSIBLE WORN DIMENSIONS		CLEARANCE NEW		PERMISSIBLE WORN CLEARANCE		REMARKS
		mm	inch	mm	inch	mm	inch	mm	inch	
1	SMALL-END Gudgeon pin in bush	55.035 to 55.050	2.1667 to 2.1673			0.035 to 0.055	0.0014 to 0.0022	0.067	0.0026	Bush bored to size after being pressed into position.
	Bush bore	54.995 to 55.00	2.1651 to 2.1653							
	Gudgeon pin diameter	60.00 to 60.03	2.3622 to 2.3633			Interference 0.042 to 0.097	0.0017 to 0.0038			
2	Bush in small-end	60.072 to 60.097	2.365 to 2.366	0.025	0.001			0.558	0.022	Total end float for each pair of big-ends between the crank webs.
	Small-end bore									
3	Bush diameter									Check that crankpin is within limits of ovality.
	ERRORS IN ALIGNMENT Errors in alignment between big and small-ends per 25.4 mm (1.0 inch) of mandrel Parallelism									
4	BIG-END Side clearance					0.20 to 0.40	0.008 to 0.016			
	Running clearance					0.026 to 0.088	0.001 to 0.003			

SECTION 8—CYLINDER HEADS AND VALVE GEAR

DESCRIPTION

The two cylinder heads, each covering a bank of four cylinders, are manufactured from close grained, high duty, cast iron and machined on the upper and lower faces for a close tolerance fit between the rocker box assemblies and cylinder block top faces respectively. Machined joint faces serve to accommodate the induction manifold on the inner, and exhaust manifold on the outer side of each cylinder head casting. Internal coolant passageways are cast into each head around the valve guides and fuel injector sleeves.

The 16 valve guides carried in each cylinder head are cast in high quality nickel chrome alloy, ground to finished size and inserted under pressure into the cylinder head casting. The inlet valve guides are distinguishable by the tapered outer diameter at the lower end.

The high quality, iron alloy, valve seat inserts are frozen into position against machined shoulders in the cylinder head flame face; the lip of each exhaust insert recess is then rolled for added security.

The fuel injectors are housed in renewable copper sleeves which are positioned in the cylinder head pockets, then expanded top and bottom to form coolant seals. The injectors are carried in their respective sleeves without joint washers, the seating face of each sleeve being re-cut as necessary when the injectors are changed.

The valve rocker gear is carried in two aluminium alloy 'rocker boxes', one for each cylinder head, and secured to their respective heads with setbolts and socket cap screws. Lubrication is provided from the auxiliary oil galleries via restrictor bobbins between each cylinder head and crankcase top face and then through drillings in each head and rocker box to the rocker shafts. From the rocker shafts, drillings direct the oil to each rocker arm bush and through the rocker arms to the push rod and valve bridge contact faces.

CYLINDER HEAD REMOVAL

The cooling system must be drained to a level beneath

the outer edge of the cylinder head flame face. Failure to do so can cause contamination of the sump oil.

A number of engine components must first be removed to enable the cylinder head to be lifted clear of the engine. A brief inspection of the engine will give a general idea of the amount of work necessary.

The dismantling sequence is as follows:

1. Disconnect the air ducting between the turbocharger and air cleaners; remove the air cleaners and support brackets.
2. Remove the fuel injector high pressure feed pipes as necessary.
3. Remove the injector spill pipework as far as the 'T' piece connection.
4. Remove the upper section of the radiator-to-induction manifold ducting where appropriate.
5. Release the thermostat-to-induction manifold hose connection.
6. Ensure that the radiator is adequately supported, then remove the appropriate stay rod.
7. Remove the exhaust manifold, complete with the two turbocharger connections on 'A' bank or the single connection on 'B' bank.
8. Disconnect the governor speed control, ('A' bank only).
9. Disconnect the turbocharger-to-radiator duct support, ('A' bank only).
10. Remove the low pressure fuel pipework between the fuel feed pump and filter header bracket, and between the filter header bracket and fuel injection pump, ('A' bank only).
11. Remove the fuel filter and header bracket, ('A' bank only).
12. Remove the exhaust elbow and turbocharger bellows unit, ('B' bank only).
13. Disconnect the fuel delivery and spill return pipes at the fuel interface unions, ('B' bank only).

14. Remove the shutdown solenoid, if mounted on the induction manifold inner wall, ('B' bank only).
15. Remove the induction manifold.
16. Remove the rocker cover.
17. Unscrew the spill connections and remove the fuel injectors.
18. Remove the rocker box and lift off the eight valve bridge pieces. Withdraw the eight pushrods.

After removal of the above components, the four alloy blanking plugs must be withdrawn from the top of the induction ports to gain access to the concealed cylinder head securing bolts.

If the engine has been placed in a build stand to remove the cylinder head, the engine should be turned to bring the cylinder head into the horizontal position.

Remove the 26 long and four short securing setbolts and fit the two Guide Studs, VT 17843, into the cylinder head bolt holes on diagonally opposite sides of the cylinder head. Fit the Lifting Bracket, VP 5007, into the manifold ports and lift the cylinder head clear of the engine. Place the cylinder head on a soft topped work bench to protect the flame face from damage.

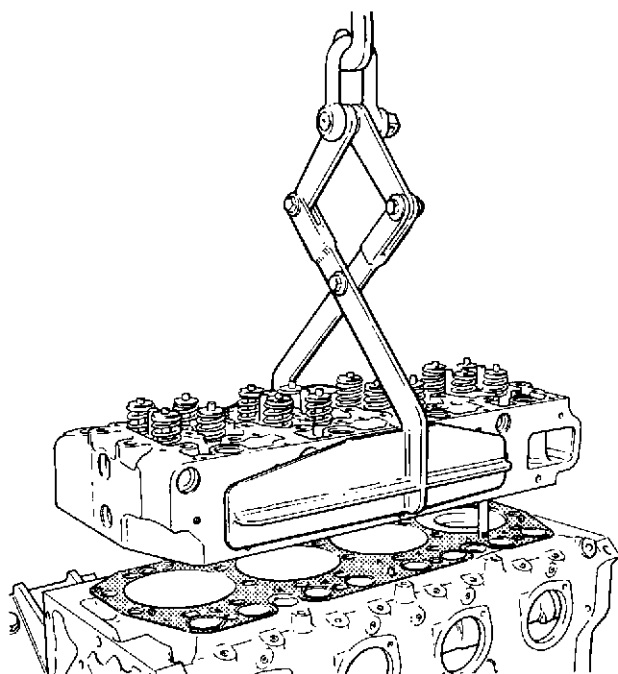

Fig. 1 Cylinder head lifting bracket VP 5007

If the engine is in its normal operating position, the cylinder head must be lifted using the Lifting Bracket, VP 7692. This allows the head to be lifted at an angle of 45 degrees from the horizontal.

Warning: To avoid any possibility of the cylinder head falling from the crankcase, the guide studs must be fitted before all the cylinder head securing bolts are removed.

Lift the oil restrictor bobbin from its location in the crankcase top face and place it in safekeeping for re-use.

Remove and discard the metal cylinder head gasket.

CYLINDER HEAD DISMANTLING AND CLEANING

Check all cup plugs for signs of coolant leaks. Any suspect plugs may be removed using the appropriate servicing kit. See SECTION 2—DISMANTLING THE ENGINE.

With the cylinder head resting, flame face down, on the work bench:

1. Screw the adaptor of the Valve Spring Compressor, VT 14037, into a suitable rocker box securing bolt hole.

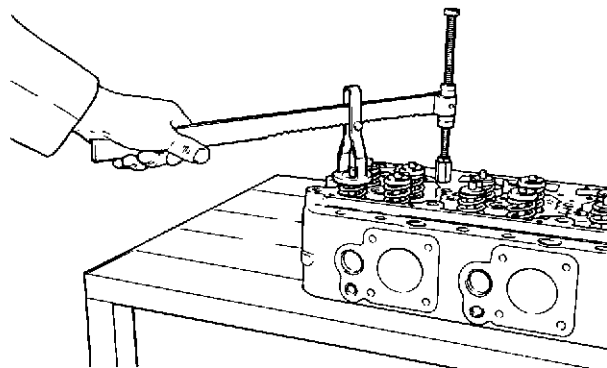

Fig. 2 Valve spring compressing tool VT-14037

2. Screw the compressor tool stud into the adaptor, finger tight, and nip up the locknut.
3. Position the arm at a convenient height on the stud, using the two knurled locknuts.
4. Position the stirrup on the arm, directly over one of the valve assemblies.
5. Compress the valve spring and lift out the collets followed by the upper spring seat or rotator, the spring and the lower spring seat.

6. Re-position the compressor tool, as necessary, until all the valve spring assemblies have been removed.

Clean all the components, using an emulsifying solvent, to Rolls-Royce recommendations. (See Data Section). Heavy carbon deposits on most components may be removed by soaking in a solution of 'MAXAN' or 'Ardrox 667'.

Caution: Valve springs must not be subjected to the 'Maxan' or 'Ardrox' cleaning process, as the surface finish may be adversely affected.

CYLINDER HEAD CASTING

If any leaking cup plugs were removed, prior to cleaning the cylinder head, they must be renewed before pressure testing.

Lightly coat the new plugs with 'Loctite 542' and insert them into the cylinder head casting, using the appropriate servicing kit.

Fit locally made blanks to the coolant apertures and connect an air supply to the coolant galleries. The air pressure must be 207 kN/sq. m. (30 lbf/sq. inch).

Immerse the cylinder head in a tank of water at 60 deg. C. and check for any bubbles from around all the cup plugs and injector sleeves. Renew any plugs or sleeves which are not air-tight.

Inspect the flame face for signs of fretting or other damage. If necessary, the face may be reclaimed by surface grinding, in four stages, to a maximum of 0.51 mm (0.020 inch). Etch details of any grinding carried out, on an area of the flame face not covered by the cylinder head gasket.

VALVE GUIDES

Check the clearance of each valve stem in its guide. This should be within the limits given at the end of the Section under 'FITS AND CLEARANCES'. If the clearance is excessive, re-check using a new valve. If the clearance is still excessive, a new valve guide must be fitted.

Renewal

Using the Valve Guide Kits, VT 12784 for exhaust valve guides or VT 12790 for inlet valve guides, proceed as follows:

1. Press out the old guide using the appropriate extractor.

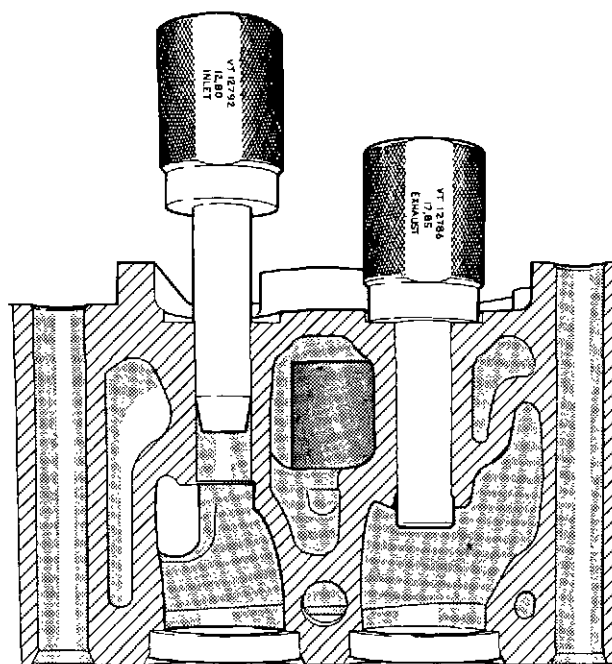

Fig. 3 Valve guide insertion tools

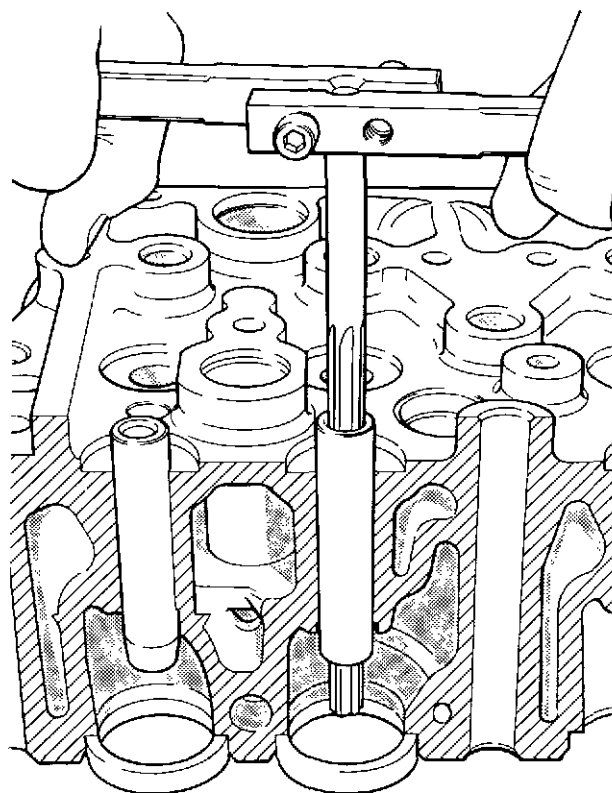

Fig. 4 Reaming valve guides

2. Prepare the new guide by lightly coating it with light machine oil and entering it into the cylinder head bore, taper end downwards for inlet valve guides or radiused end down for the exhaust valve guides.
3. Place the appropriate insertion tool over the top of the guide and, using a hand press, press the guide into position until the insertion tool contacts the valve spring seat landing. This will give the correct protrusions of 12.8 mm (0.50 inch) for inlet valve guides or 17.85 mm (0.70 inch) for exhaust valve guides.
4. Ream the new valve guide and check the bore with the appropriate plug gauge.

When new valve guides have been fitted, the associated valve seat insert must be re-cut using the Kit, VT 14049, to ensure concentricity.

VALVE SEAT INSERTS

Inspect all the inserts for pitting, cracks and valve bedding. The seating face may be restored by lapping in or, in severe cases, by cutting the face at the correct angle i.e. 45 deg. for exhaust valves and either 30 deg. or 45 deg. for the inlet valves as appropriate. The Servicing Kit, VT 14049, is available for this purpose.

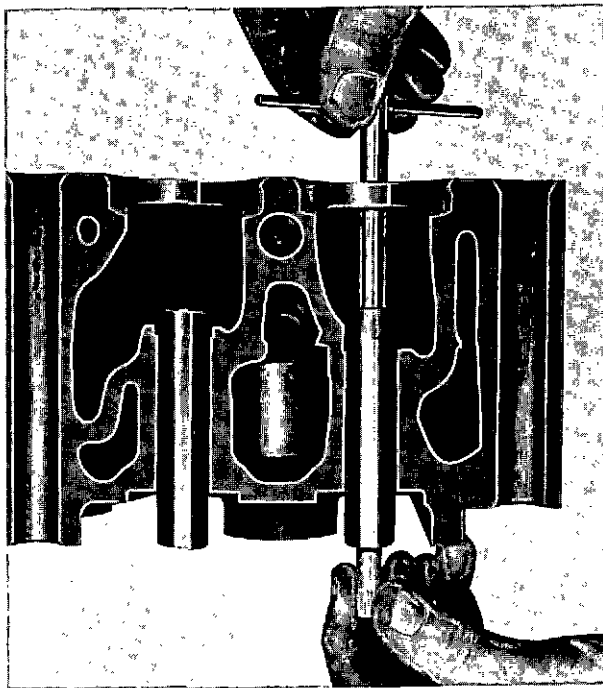

Fig. 5a Fitting cutter guide

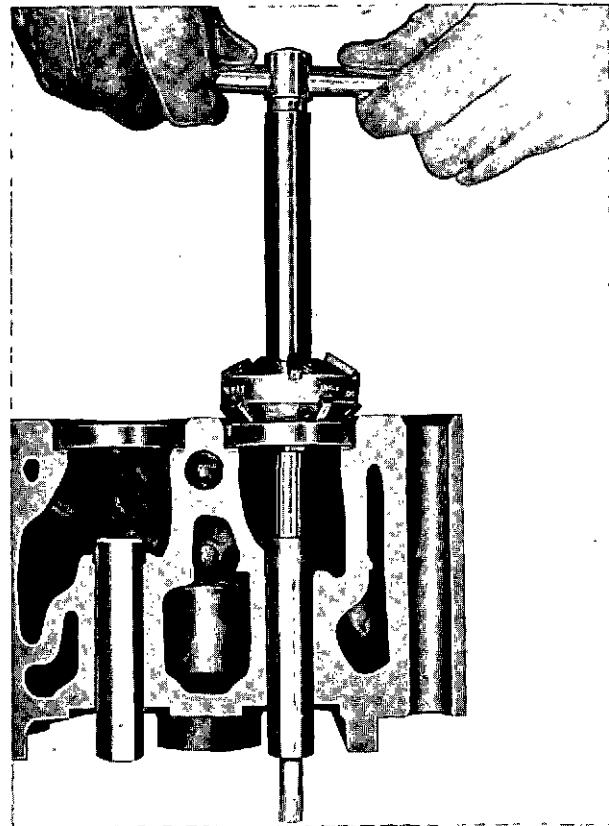

Fig. 5b Cutting valve seat insert

Note: When restoring a seating face, it is important that only the minimum amount of metal is removed.

After reconditioning the seat insert and its valve (see 'VALVES', this Section), fit the valve into the guide and check the clearance of the valve head below the cylinder head flame face. If the clearance is beyond the limits, given at the end of this Section, re-check using a new valve. If the clearance is still beyond the permissible limits, a new valve seat insert must be fitted.

Removing an insert

Before an exhaust valve set insert can be removed, the rolled over edge of the cylinder head casting must be cut away. A Hand Cutter, VT 13768, and Arbor, VT 13713, are available for this purpose. (See illustration).

For the removing and fitting of valve seat inserts, a Renewal Kit, VT 12799, is available.

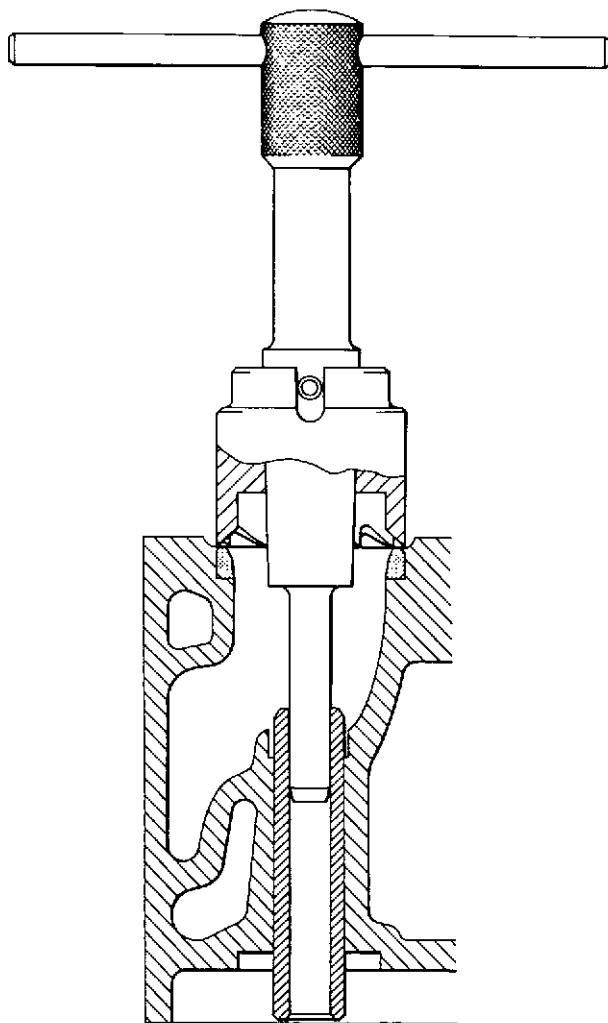

Fig. 6 Cutting tool and arbor

Important: Before attempting to remove any valve seat inserts, the cylinder head must be checked to see if reclamation of the flame face has been carried out. If the flame face has been machined, the insert cutter assembly must be adjusted accordingly by inserting the appropriate sized feeler gauge between the end of the cutter and the setting gauge, before locking the stop collar. This will ensure that the cutter does not break through the insert and damage the cylinder head insert shoulder.

Assuming that the relevant valve guide is in position and is not excessively worn in the bore, proceed as follows:

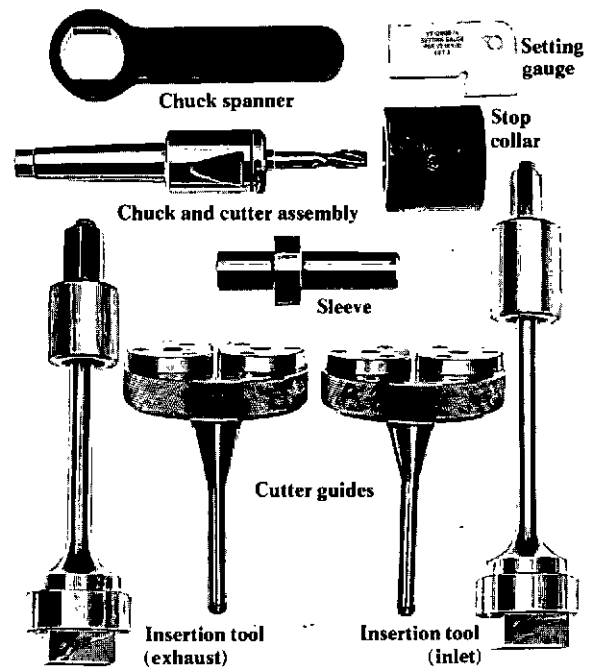

Fig. 7 Insert renewal kit VT 12799

1. Secure the cylinder head, flame face up, on the table of a milling machine.
2. Fit the taper shank chuck to the machine and lock in the cutting tool.
3. Slide the stop collar over the chuck, with the grub screw aligned with the flat location on the side of the chuck.
4. Using the setting gauge, position the stop collar accurately and tighten the grub screw.
5. Fit the appropriate bush, cutter guide into the valve guide and cut into the valve seat insert until the stop collar contacts the upper face of the bush.
6. Repeat this operation, using the second bush, to give two holes radially opposite to each other in the valve seat insert.

It should then be possible to break out the damaged insert by inserting a steel rod in the cutter holes and levering slightly.

If the valve guide is worn, it must be renewed or removed before cutting the valve seat insert.

To remove a valve seat insert when the valve guide is not fitted proceed as follows:

1. Push the Sleeve, VT 12805, into the cylinder head valve guide bore before turning the head over.

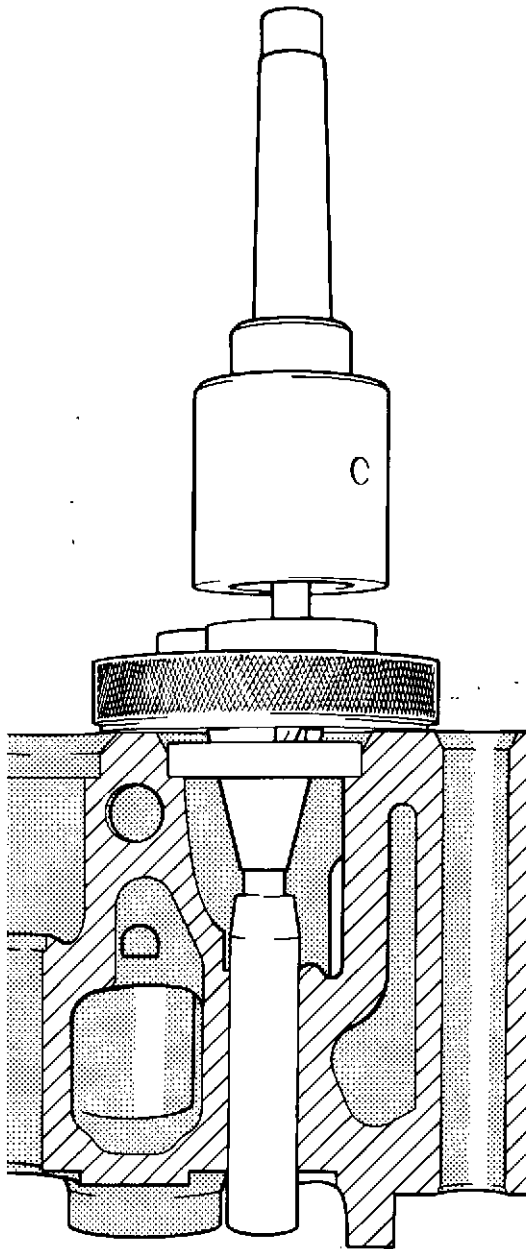

Fig. 8 Valve seat insert cutting

2. Rest the cylinder head on two parallel support bars on the table of the milling machine, ensuring that the lower end of the sleeve is clear of the table before clamping the cylinder head.
3. Remove the valve seat insert as previously described, using the inlet insert bushed guide, VT 12800, for both exhaust or inlet valve seat inserts.

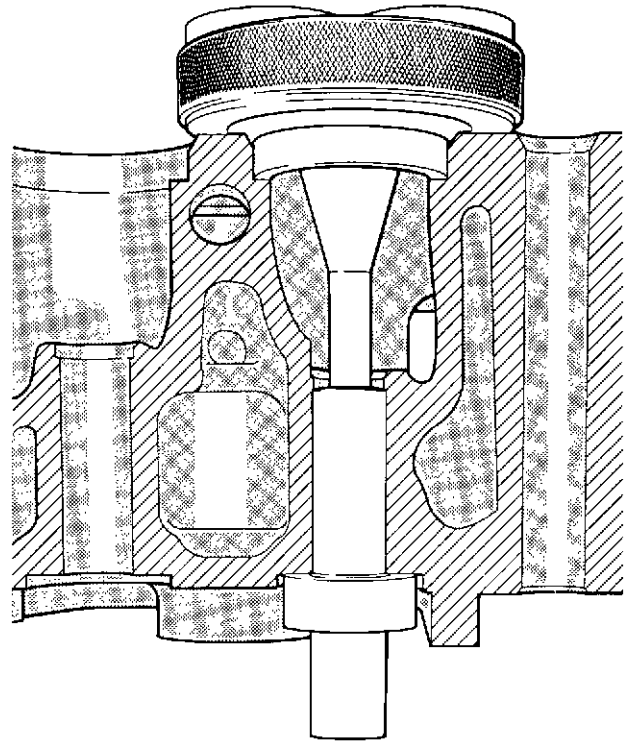

Fig. 9 Insert cutter guide in sleeve

Fitting new inserts

Valve seat inserts are available in two sizes, standard and service, the service insert being 0.05 mm (0.002 inch) larger on the outer diameter. If a service insert is to be fitted, the cylinder head recess wall must be machined prior to fitting, to maintain the correct interference fit as given in 'FITS AND CLEARANCES' at the end of the Section.

Before renewing inlet valve seat inserts, see note under 'VALVES', this Section.

Ideally, the replacement insert should be frozen in liquid air immediately before fitting. If this is not possible, the cylinder head must be heated in boiling water for 30 minutes and the insert drawn in as quickly as possible.

Two valve seat Insertion Tools VT 12903 and VT 12804, are included in the renewal kit. As with the cutter guides, these tools require the valve guides to be in position or the sleeve, VT 12805, pushed into the cylinder head valve guide bore. Both inlet and exhaust valve seat inserts must be positioned using the inlet insertion tool when the Sleeve, VT 12805, is being used.

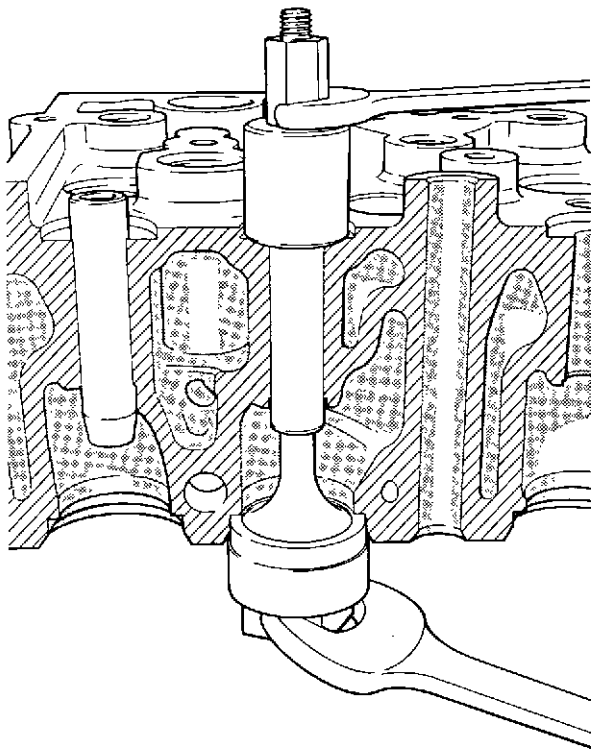

Fig. 10 Fitting insert with valve guide in position

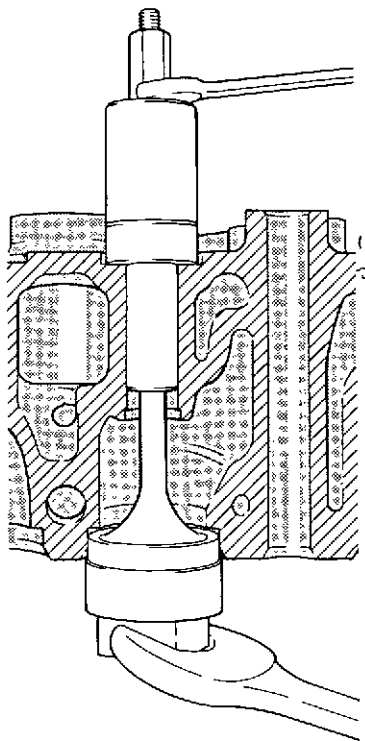

Fig. 11 Fitting insert using sleeve

Check by feeler gauge that the insert is fully home.

After renewing an exhaust valve seat insert, the cylinder head casting must be rolled around the circumference of the insert. If the insert has been fitted using the Sleeve, VT 12805, the valve guide must first be pressed into its bore, (see 'VALVE GUIDES', this Section), before the insert can be rolled in.

The rolling in procedure is as follows:

1. Position the Rolling Tool, VT 18340, in the Setting Ring, VT 18341, and set the rollers as follows:
 - (a) Slacken the securing screws on each roller holder, and the locknut on each stop screw.
 - (b) Using the appropriate feeler gauges, adjust each roller holder in turn so that the clearance between the roller and the setting ring is 0.50 mm (0.020 inch). Tighten each securing screw and stop screw locknut.

Note: Ensure that the head of the stop screw is backed against the tool housing when setting the clearance.
 - (c) Re-check each roller clearance and reset any roller holder, if necessary, before using the tool on the cylinder head.
2. Coat the rollers and the counterbore in the cylinder head with clean engine oil. Locate the rolling tool in the valve guide and rotate slowly, applying sufficient pressure to 'spread' the cylinder head material into the valve seat insert chamfer. When the tool housing face contacts the stop plate, the insert is fully rolled in and the tool should be removed.

If applicable, fit new inlet valve guides as previously described.

Cut or grind the valve seat inserts at the correct angle, i.e. 30 deg. or 45 deg. dependent on the type in use. Lap in the valves and check with blue marking that the valves are seating around the full circumference of the contact faces.

Finally assemble the valves to the cylinder head and, using a straight-edge and feeler gauge, check the clearance between each valve head and the cylinder head flame face. If the clearance is beyond the permissible limits, a new valve must be fitted.

VALVES

After thoroughly cleaning, carefully inspect each valve

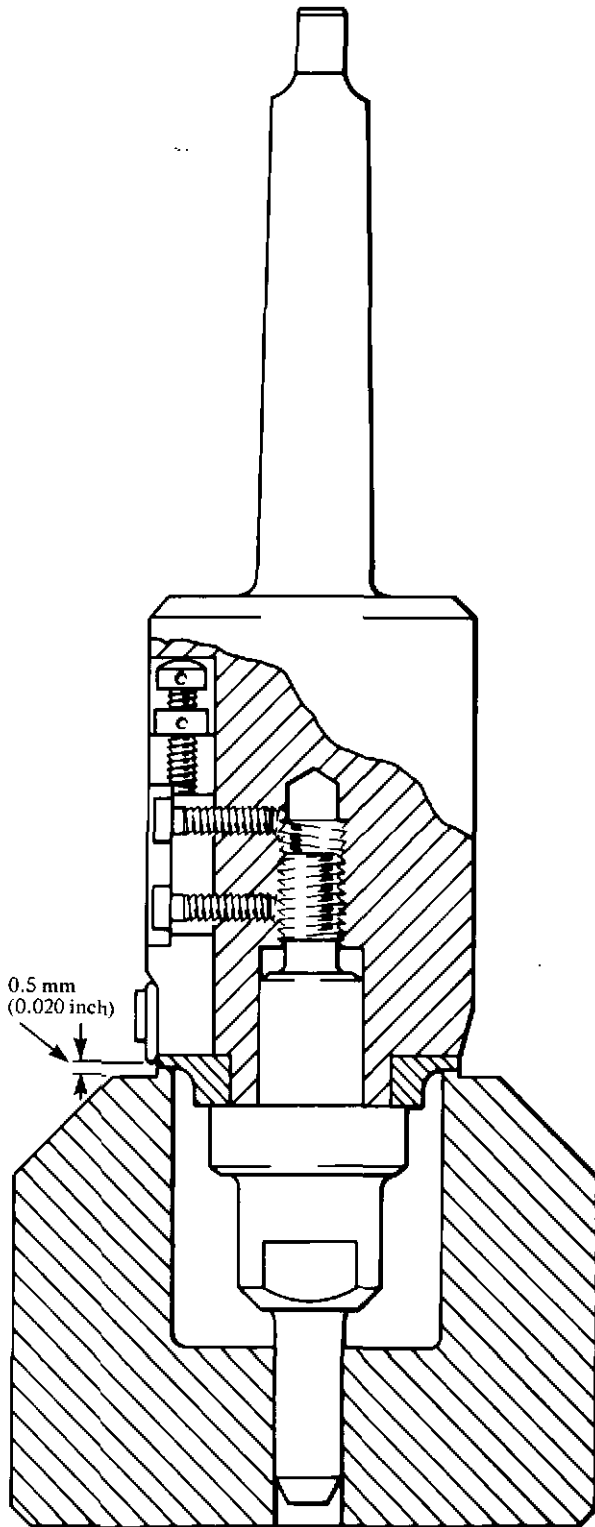

Fig. 12 Rolling in tool in setting ring

for cracks, pitting or other damage to the head. Check the valve stems, collet grooves and tips for wear. On apparently serviceable valves, test the heads for cracks using a dye penetrant process such as 'Ardrox 996'. See Data Section for details.

Check the valve for 'dishing' by means of a straight-edge and feeler gauge. Scrap any valve if the clearance exceeds 0.13 mm (0.005 inch).

Assemble each valve to the cylinder head and check the seating, lapping in the valve if necessary.

Finally check the clearance between the valve head and clearance head flame face. If it is more than the permissible clearance given at the end of this Section, re-check using a new valve. If there is still too much clearance, a new valve seat insert must be fitted. Insufficient clearance can be rectified by cutting the seating face of the insert, as previously described.

If any new valves are fitted, their cylinder number and position should be etched near the top of the stem. Valves must not be stamped or pop marked as this may initiate cracking of the valve stem.

Note: If severe bedding or wear is experienced on the earlier type 45 deg. inlet valves and valve seat inserts, it is recommended that the valves and seat inserts be replaced by the later 30 deg. versions. These components must be renewed in sets.

VALVE SPRINGS

Thoroughly clean the valve springs and check for wear, corrosion and distortion. Measure the free length and length under load as specified in 'FITS AND CLEARANCES' at the end of the Section. Scrap any spring which is unsatisfactory.

If one spring on any pair of valves is faulty or damaged, both springs on the pair of valves must be renewed. Old and new springs mixed on any pair of valves can cause wear to the valve bridge and guide.

Check any new springs, to ensure that they are correct for the engine, by noting the green identification mark on the spring coils.

VALVE ROTATORS

Check the rotators for cracks and other damage and ensure that the parts rotate freely, relative to each other.

Inspect the valve stem tips. If the wear pattern indicates that the valve has not been rotating, the

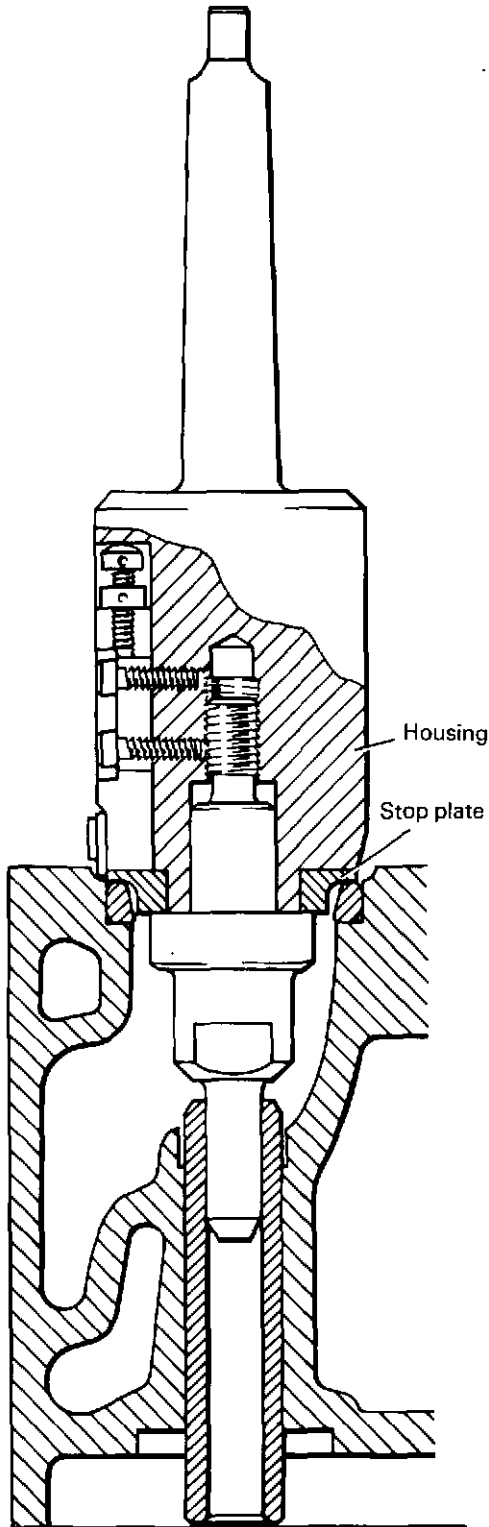

Fig. 13 Rolling in tool

rotator for that particular valve must be renewed even if it appears to be serviceable.

Note: Rotators are fitted in place of the upper spring seats on exhaust valves only.

VALVE BRIDGES AND BRIDGE GUIDES

Inspect the valve bridges and adjusting screws for wear. Check the bridge bores using a new bridge guide as a gauge, and check the bridge guides using a new valve bridge. Renew any compartments which show excessive slackness.

Using the Renewal Kit VT 12796, withdraw any worn valve bridge guide and clean out its cylinder head bore.

Lightly coat any new bridge guides with machine oil, and insert them into their bores using a hand press. To obtain the correct protrusion, each guide must be pressed into its bore until the top face is flush with the top face of the insertion sleeve.

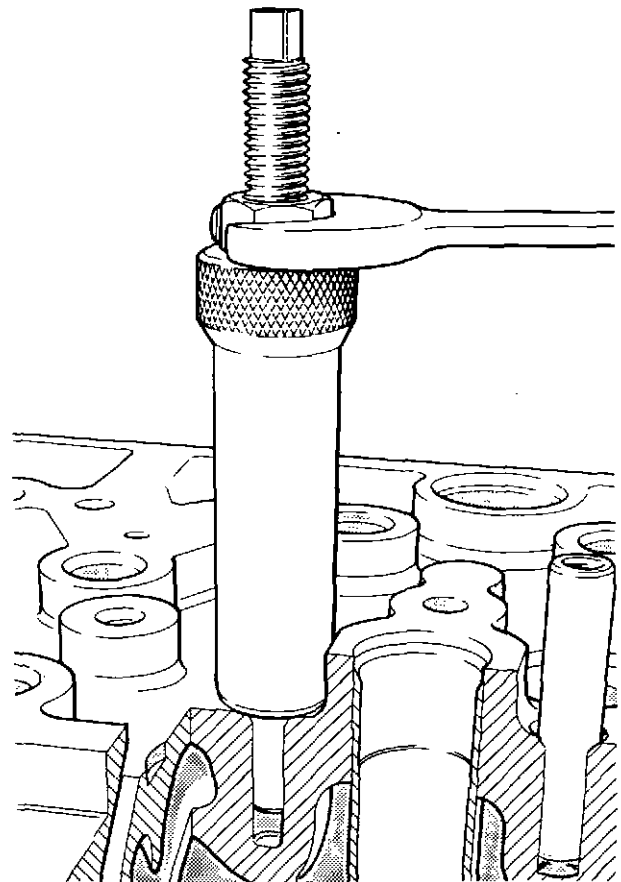

Fig. 14 Withdrawing valve bridge guide

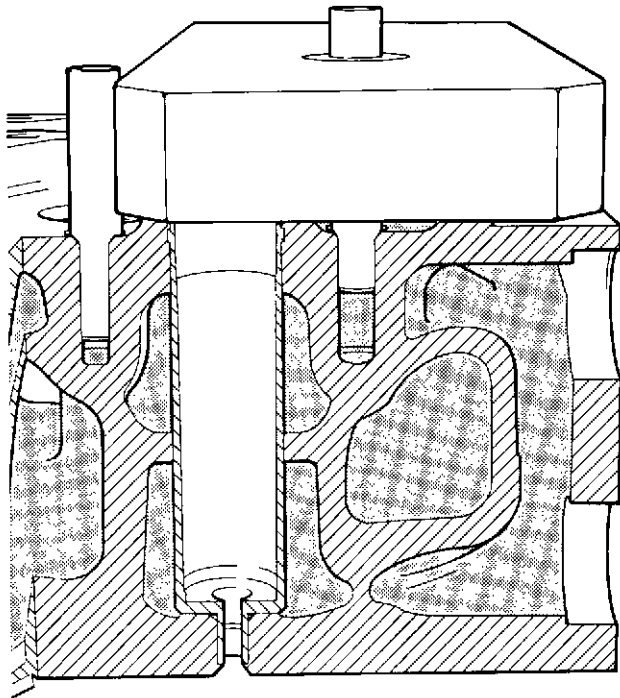

Fig. 15 Valve bridge guide insertion sleeve

PUSHRODS

Examine the ends of each pushrod for wear and damage and check each rod for 'bowing'. Any pushrod having a runout of more than 0.2 mm (0.008 inch) over its total length must be renewed.

INJECTOR SLEEVES

Reconditioning injector sleeves

Using the seating face cutter and nozzle reamer from the Service Kit, VT 12772, remove any build up of carbon or injector seating face damage.

Important: When using the seating face cutter, remove the minimum amount of metal necessary to restore the seating face. The maximum permissible depth of the seating measured from the cylinder head top face is 104.25 mm (4.104 inches).

Renewing injector sleeves

Any injector sleeve which has been re-cut beyond the limit, or has been damaged, or is leaking from the expanded joints and cannot be rectified by further expansion of the sleeve ends, must be renewed as described below.

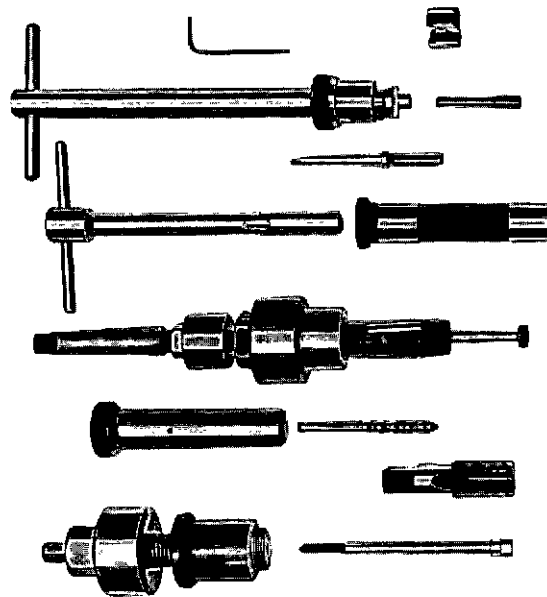

Fig. 16 Injector sleeve service kit VT 12772

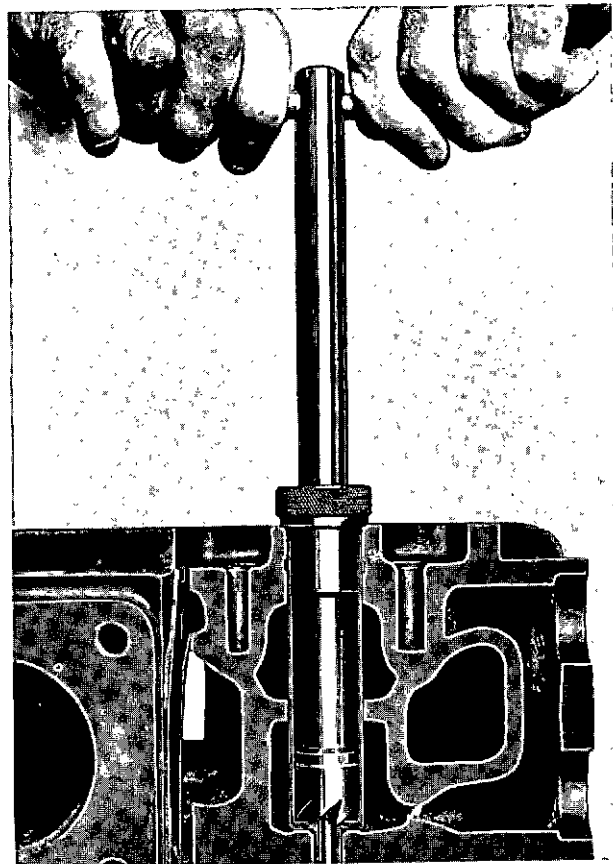

Fig. 17 Seating face cutter

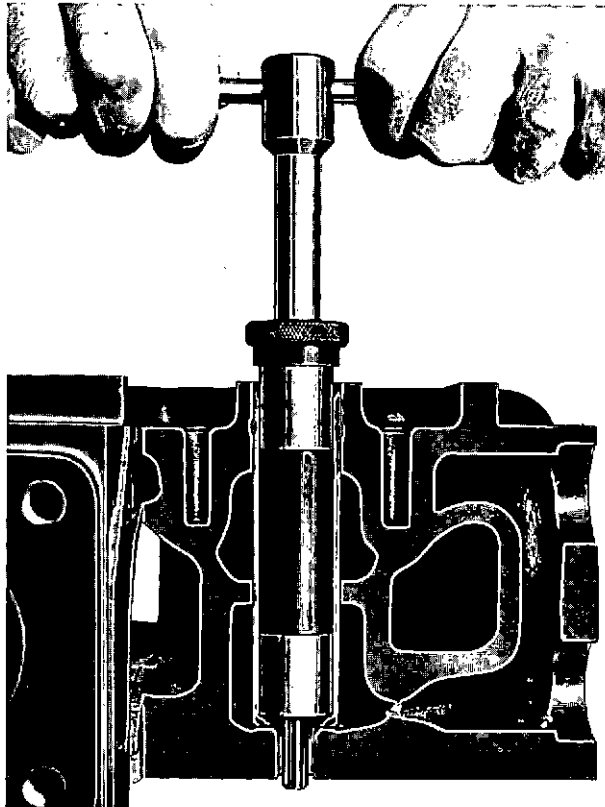

Fig. 18 Nozzle reamer

1. Using the Tap, VT 11103, cut a thread in the sleeve to a depth of at least 25 mm (one inch).

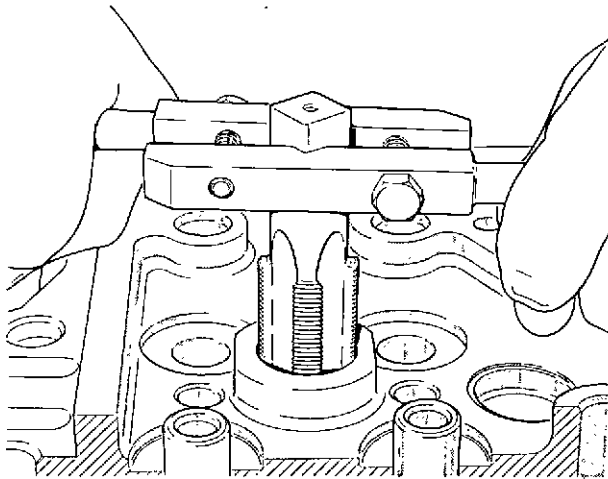

Fig. 19 Tapping injector sleeve

2. Run the nut of the Extractor, VT 11102, to the top of its thread, and run the screw fully into the injector sleeve tapping.

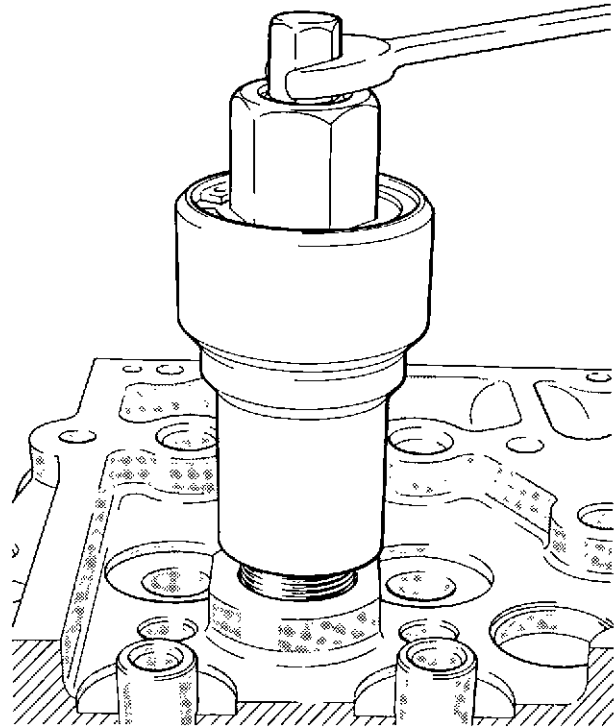

Fig. 20 Fitting extractor VT 11102

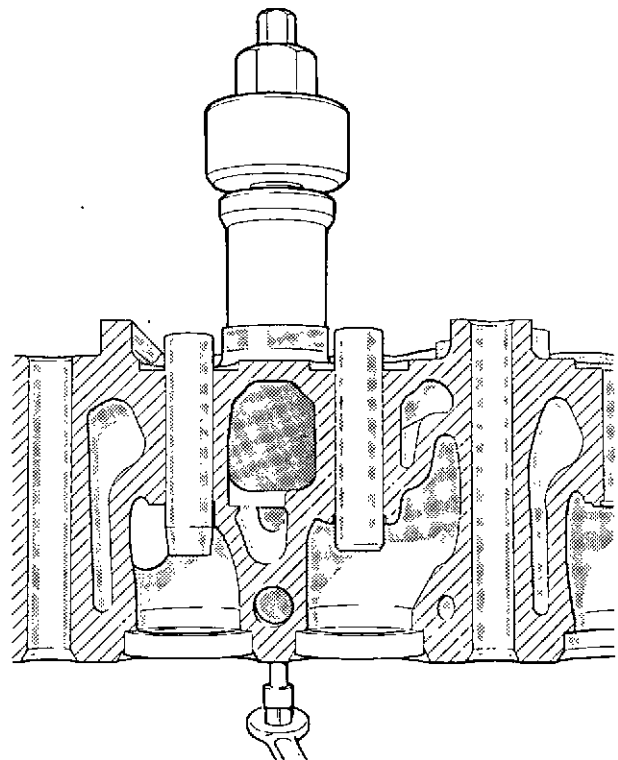

Fig. 21 Fitting stud in extractor

3. Screw the stud in through the injector nozzle until the shoulder of the stud contacts the lower face of the nozzle.
4. Tighten the nut down against the thrust face/housing assembly and draw out the injector sleeve.

Note: Considerable effort will be required to shear the rolled out diameter of the sleeve.

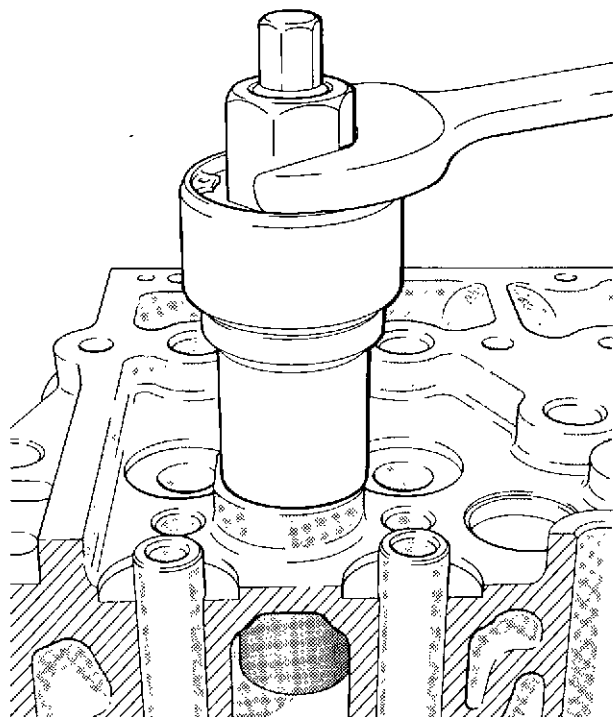

Fig. 22 Withdrawing injector sleeve

5. Clean out the cylinder head bores and sleeve expansion groove, and fit the service sleeve into the pocket.

Note: Ensure that the new sleeve is fully home before the next operation is carried out.

6. Rest the cylinder head, flame face down, on parallel supports on the bed plate of a hand press. Ensure that the supports are deep enough to allow the Expander Tool, VT 10601, to clear the bed plate.
7. Smear the 'Ballizing' section of the tool with grease and slide the tool into the injector sleeve as shown in the illustration. Slowly press the tool down until the pilot reaches the injector seating face. Remove the 'Ballizing' section of the tool from beneath the cylinder head flame face. The pilot section may be withdrawn from the top.

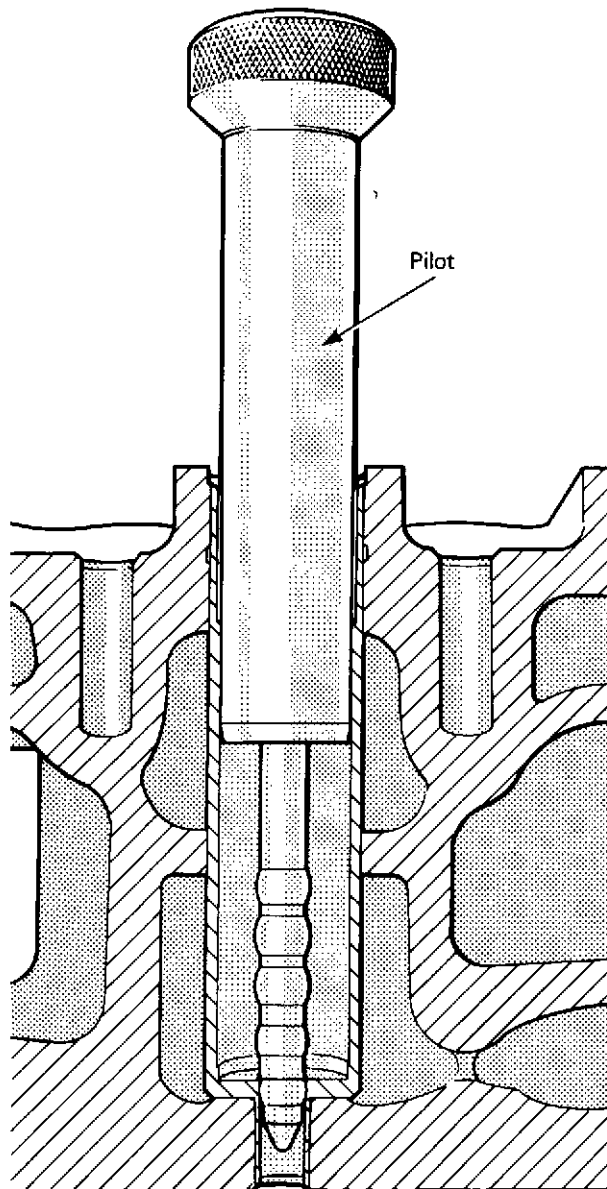

Fig. 23 Expander tool VT 10601

When the injector nozzle has been expanded, the top of the sleeve must then be rolled out using the Expander Tool, VT 10619.

8. Measure the depth of the injector sleeve counter-bore from the cylinder head top face and adjust the depth of the rollers, as shown, until the lower end of the rollers fit into the shoulder of the counter-bore. Lock the adjusting nut by tightening the grub screw against the flat machined in the adjusting sleeve thread.

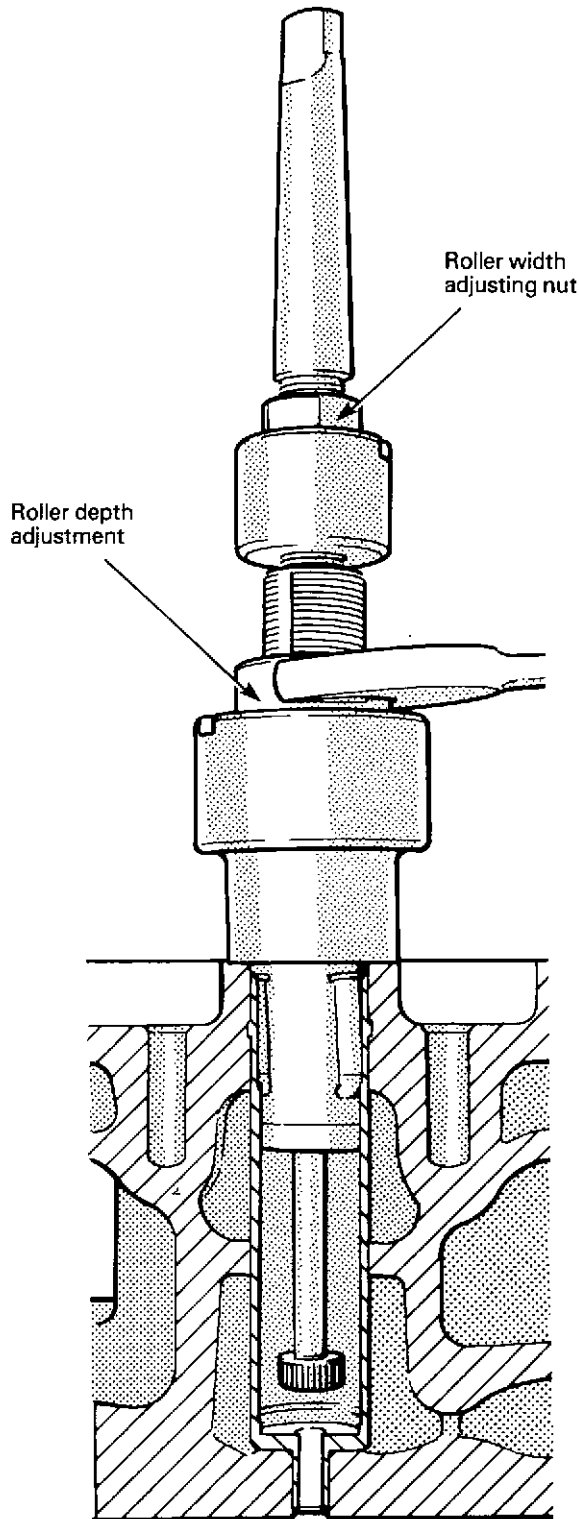

Fig. 24 Expend tool VT 10619

9. Adjust the roller width, using the tapered shaft adjusting nut, until the rollers are pressing firmly against the wall of the injector sleeve. Lock the nut to the shaft by tightening the grub screw against the flat in the shaft thread.
10. Turn the tool at slow speed for three or four revolutions, then re-adjust the roller width as instructed in Item 9.
11. Continue to turn and adjust the rollers in stages until the injector sleeve is rolled out sufficiently to show a band of different coloured metal, where the cylinder head groove encircles the injector sleeve.

Once the final roller width has been ascertained, the tool may be used to expand other replacement sleeves without further adjustment to the depth and width settings.

When rolling out a sleeve with a pre-set expander tool, the tool must be turned slowly under steady pressure until the depth stop contacts the cylinder head top face.

CYLINDER HEAD ASSEMBLING

Oil the valve stems, fit each valve into its guide, then place the lower spring seat, spring and spring retainer or valve rotator, as applicable, over the valve stem.

Compress the spring assembly and fit the collets into the valve stem locating groove. Release the valve spring compressor carefully, then proceed to the next assembly.

When all the valve assemblies are in place, fit the valve bridge pieces on to the bridge guides and set the adjustment as detailed in Section 3.

CYLINDER HEAD FITTING

Check the joint faces for cleanliness and ensure that the locating dowels in the crankcase top face are serviceable.

Fit the oil transfer bobbin, with new sealing ring, into its recess and place a new cylinder head gasket on the crankcase top face; fit two guide studs into diagonally opposite cylinder head bolt holes.

Lower the cylinder head on to the crankcase and fit the cylinder head bolts as detailed in Section 3—Items 46 to 49.

Note: To avoid damage to the threads, the bolts should be placed in the bolt holes, and not dropped in.

Lightly coat the valve bridge guides with clean engine oil and, with the adjusting screws and locknuts slackened off, place each bridge piece on to its guide with the adjusting screw nearer the outer edge of the cylinder head.

In turn, press down firmly on the centre of each bridge piece and turn the adjusting screw until it is felt to *just* touch the valve stem tip. Turn the screw a further 60 deg. (1/6 turn) and tighten the locknut to a torque loading of 40 Nm (30 lbf. ft.).

Caution: It is important that no side load is placed on the valve stems when tightening the adjusting screw locknuts.

Fit the rocker box, with a new jointing gasket, to the cylinder head and adjust the valve clearances as described in Section 3.

Refit any components previously removed in the reverse order to dismantling, checking the fits and clearances where applicable.

SPECIAL TOOLS

Part No.	Description
VT 17843	Guide studs, cylinder head.
VP 5007	Lifting bracket, cylinder head.
or VP 7692	Lifting bracket, cylinder head.
VT 14037	Compressor, valve spring.
VT 12784	Renewal kit, valve guide (exhaust).
VT 12790	Renewal kit, valve guide (inlet).
VT 14049	Cutter kit, valve seat insert.
VT 13768	Cutter, valve insert rolled edge (exhaust).
VT 13713	Arbor for VT 13768.
VT 12799	Renewal kit, valve seat insert.
VT 18340	Rolling tool, valve seat insert (exhaust).
VT 13341	Setting ring for VT 18340.
VT 12796	Renewal kit, valve bridge guide.
VT 12772	Servicing kit, injector sleeve.
Cup plug kit as necessary. See Section 2 for sizes.	

**FITS AND CLEARANCES
CYLINDER HEADS AND VALVE GEAR**

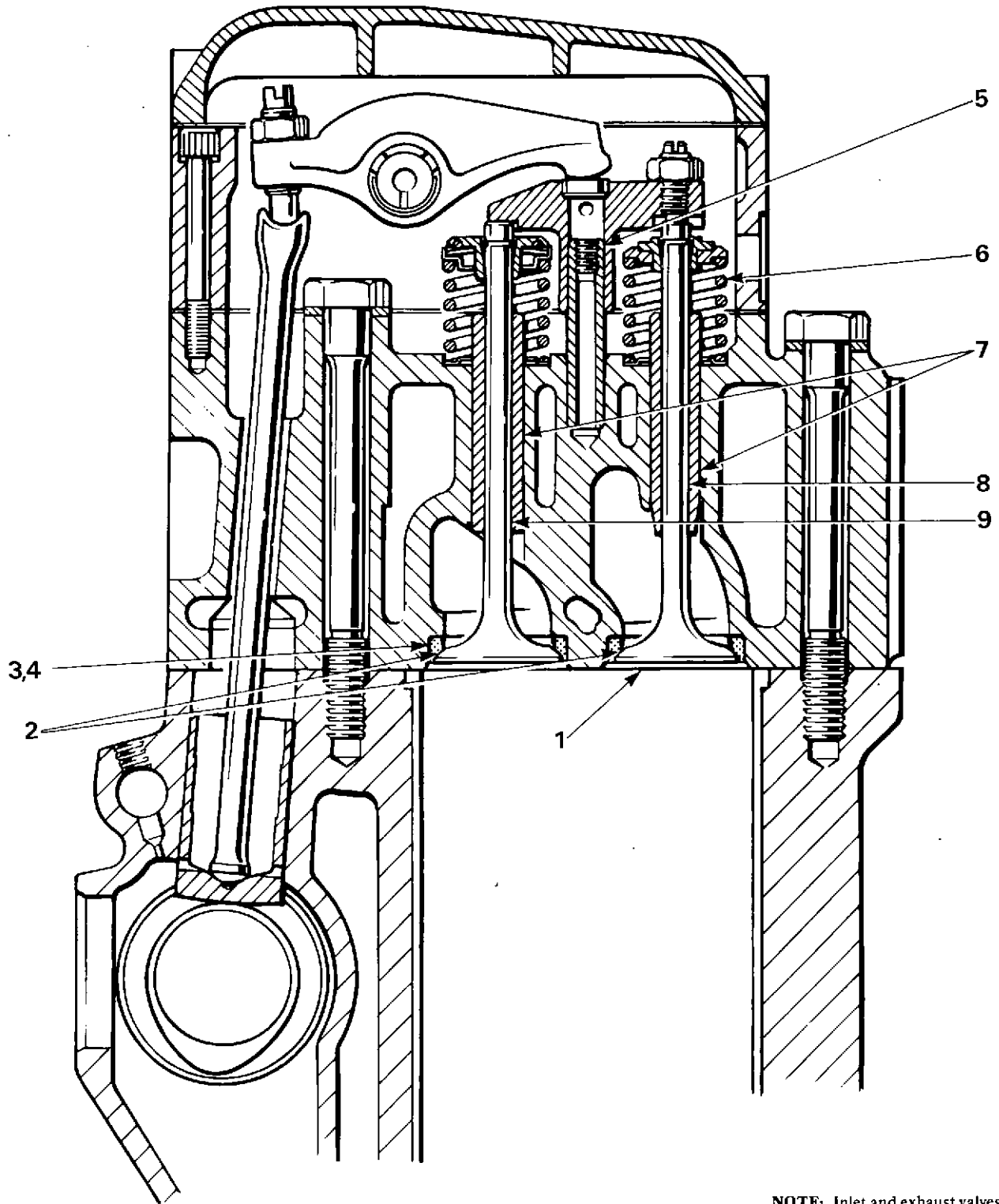

NOTE: Inlet and exhaust valves are shown under one valve bridge for convenience.

ROLLS-ROYCE DIESELS

No. ON DIAG.	DESCRIPTION	DIMENSIONS NEW		PERMISSIBLE WORN DIMENSIONS		CLEARANCE NEW		PERMISSIBLE WORN CLEARANCE		REMARKS
		mm	inch	mm	inch	mm	inch	mm	inch	
1	VALVE IN SEATING Clearance below flame face Inlet valves					1.000 to 1.320	0.0393 to 0.0519			
	Exhaust valves					1.003 to 1.383	0.0395 to 0.0544			
2	VALVE SEAT INSERTS Angle of valve seat inlet inlet exhaust	30 deg. 45 deg. 45 deg.								
3	Inserts in cylinder head Cylinder head bore	48.00 to 48.016 48.054 to 48.065	1.889 to 1.890 1.8919 to 1.8923			Interference 0.038 to 0.065	0.0015 to 0.0025			Later engines Early engines
4	*Insert diameter									
5	VALVE BRIDGES ON VALVE BRIDGE GUIDES Valve bridge bore	12.755 to 12.780 12.728 to 12.739	0.5021 to 0.5031 0.5011 to 0.5015			0.016 to 0.052	0.0006 to 0.002	0.10	0.004	
6	VALVE SPRINGS Free length (Nominal) Load when compressed to 26.87 mm (1.058 inch)	47.066 0.5071 kN to 0.5605 kN	1.853 114 lbf. to 126 lbf.	44.713	1.760					
7	VALVE GUIDES Valve guides in cylinder head Cylinder head bore Valve guide diameter	18.00 to 18.02 18.028 to 18.041	0.7086 to 0.7094 0.7097 to 0.7102			Interference 0.008 to 0.041	Interference 0.0003 to 0.0016	Interference 0.008	0.0003 0.0016	

* Standard items. Replacement inserts 0.05 mm (0.002 inch) oversize, are available.

ROLLS-ROYCE DIESELS

No. ON DIAG.	DESCRIPTION	DIMENSIONS NEW		PERMISSIBLE WORN DIMENSIONS		CLEARANCE NEW		PERMISSIBLE WORN CLEARANCE		REMARKS
		mm	inch	mm	inch	mm	inch	mm	inch	
8	VALVES IN GUIDES Inlet valve stem diameter	9.464	0.3725							Belling at lower end of guide bore not to exceed 0.51 mm (0.02 inch) on diameter.
		to	to							
		9.482	0.3733			0.043	0.0016			
		9.525	0.3749			to	to	0.19	0.0075	
9	Inlet valve guide bore	to	to			0.086	0.0034			Belling at lower end of guide bore not to exceed 0.51 mm (0.02 inch) on diameter.
		9.550	0.3759							
		10.930	0.4303							
		to	to			0.051	0.002	0.20	0.008	
	Exhaust valve stem diameter	10.947	0.4309							
		to	to			0.093	0.0036			
		10.998	0.4329							
		to	to							
	Exhaust valve guide bore	11.023	0.4339							

SECTION 9 — ROCKER BOXES

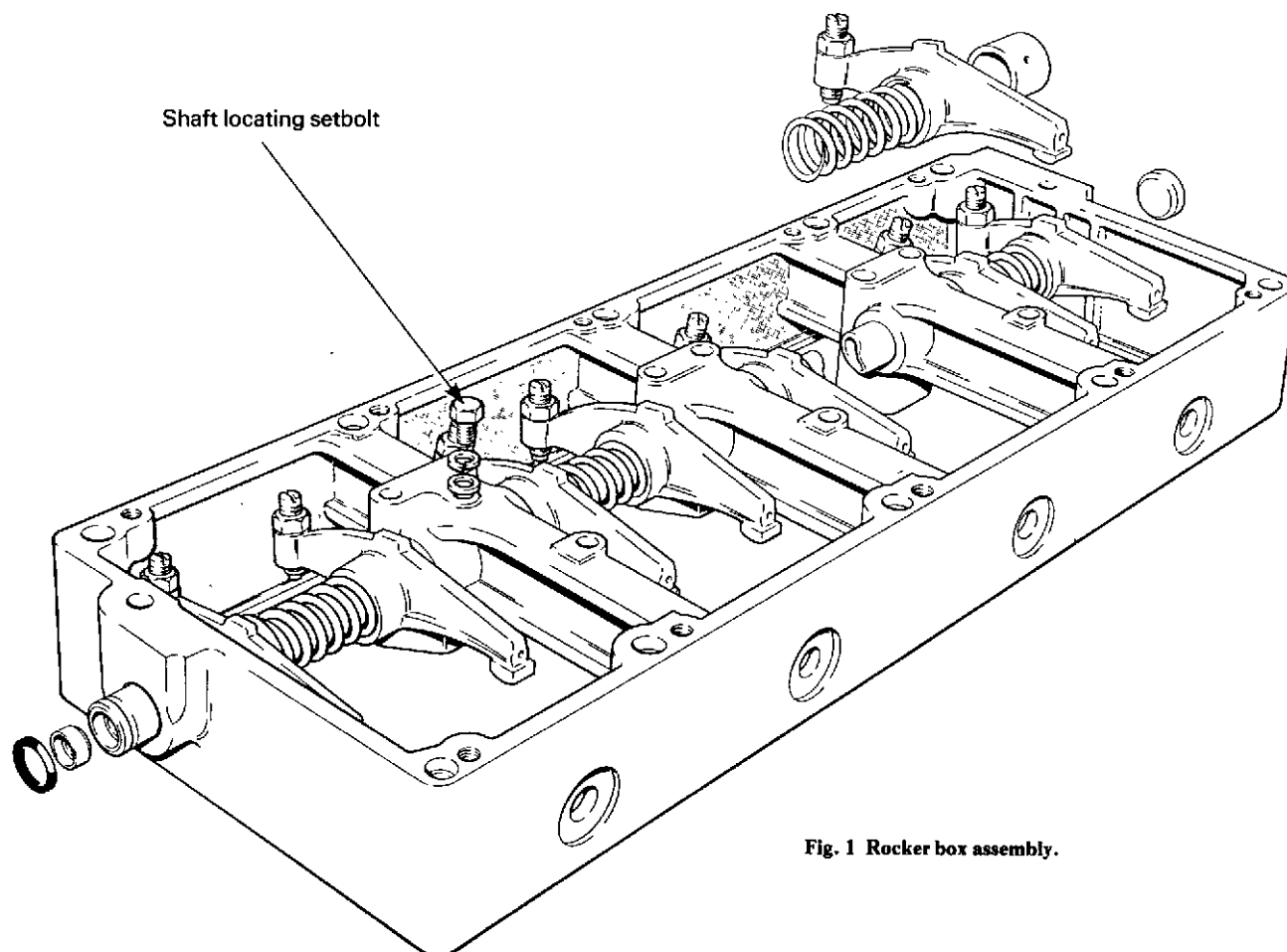

Fig. 1 Rocker box assembly.

DESCRIPTION

The two rocker boxes, manufactured as aluminium alloy castings are located on their individual cylinder heads by two spring dowels, and secured with eleven setbolts with plain and spring washers and ten socket capscrews. A drilling in the lower face of the central pedestal section carries the rocker gear lubricating oil from the cylinder head oilway to the rocker shaft. One full length rocker shaft in each box is manufactured from medium carbon steel and induction hardened around each rocker journal. The shaft,

which is bored and drilled for rocker gear lubrication, is positioned in its rocker box by a single locating setbolt which is screwed into the left hand pedestal section, viewed from the outer edge of the rocker box.

The eight rocker arms operating on each shaft are of forged steel with induction hardened pads. Steel backed, lead bronze bushes provide a bearing surface in each rocker arm. A standard type adjusting screw and locknut is fitted to the inner end of each arm, to permit tappet setting. Axial location of each pair of rocker arms is governed by four coil springs around the rocker shaft.

Four holes bored through the outer side of each rocker box provide interfaces for fuel injector spill connections.

An aluminium alloy cover is secured to each rocker box with ten setbolts, with plain and spring washers. Four holes drilled through the cover provide for fuel injector feed connections.

Removing rocker box

To remove a rocker box, the injector feed and spill pipework must first be removed as necessary. If the 'A' bank rocker box is to be removed, unscrew the fuel filter canister, disconnect the associated pipework and remove the fuel filter header bracket.

Remove the rocker cover and unscrew the injector spill connections.

Slacken back all the rocker adjusting screws as far as possible then, evenly and progressively, slacken the rocker box securing setbolts and socket capscrews. The valve spring pressure will lift the rocker box clear of the cylinder head. Remove the setbolts and capscrews and lift off the rocker box.

Dismantling

If applicable, withdraw the cup plug from the rocker box shaft bore. Remove the rocker shaft locating setbolt and push the shaft to the left, viewed from the outer edge of the rocker box, until the 'O' ring seal around the shaft can be lifted off. Continue withdrawing the shaft, lifting out each rocker arm and spring as they become free.

When no cup plug is fitted into the rocker box shaft bore, the rocker shaft must be pushed in one direction sufficiently to remove one 'O' ring seal from around the end of the shaft. The shaft must then be pushed in the opposite direction to release the 'O' ring from the other end before the rocker arms and springs can be removed.

Cleaning and inspection

Remove any grease and dirt from the components using an emulsifying solvent then wash and dry each item before inspection.

Smooth any slight ridges on the rocker pads using an oil stone, ensuring that the finished surface is at 90° deg. to the sides of the pad.

Renew any worn rocker bush by pressing it out using the Removal Tool, VT12814, and a hand press. Check the rocker arm bore for scoring or other

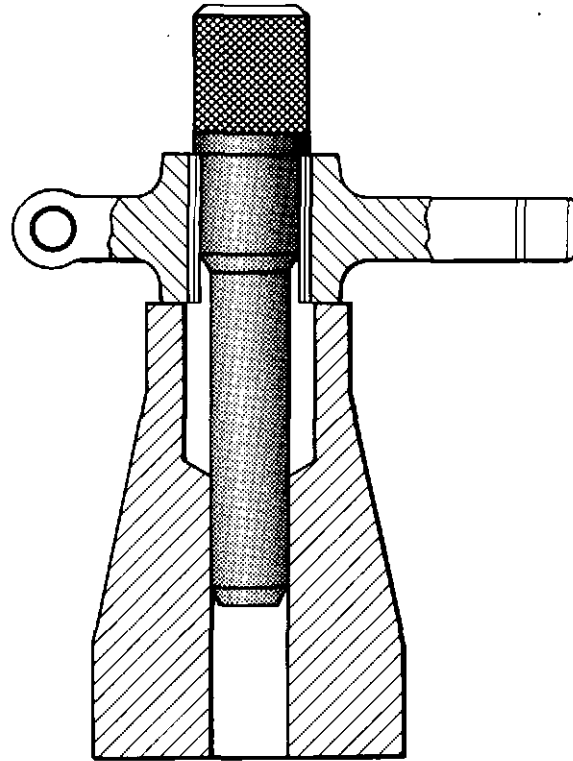

Fig. 2 Extracting rocker arm bush.

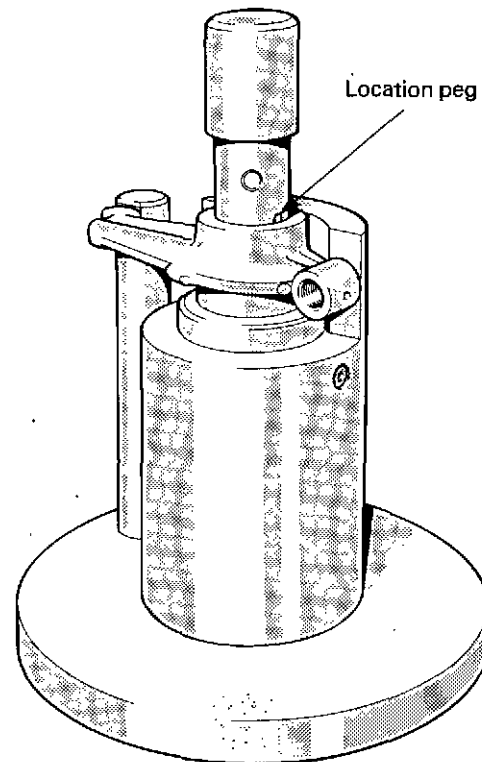

Fig. 3 Inserting rocker arm bush.

damage and using the Insertion Tool VT 10693 press the new bush into the rocker arm until the tool cap contacts the rocker arm side face. Oil hole positioning is provided for by the location peg in the tool spindle.

Replacement bushes are pre-finished and require no reaming during rocker gear assembly.

Assembling the rocker box

For rocker boxes having the rocker shaft bore plugged at one end, oil the shaft and enter the open end into the rocker box bore. Ensure that the oil feed hole in the centre of the shaft is facing downwards (towards the cylinder head). Push the shaft through far enough to slide on the first rocker arm. Continue to push the shaft through the pedestal sections fitting the rocker arms and springs in correct sequence.

Before pushing the shaft fully home fit the 'O' ring seal around its groove in the shaft and push the shaft in until the locating bolt hole in the shaft is aligned with the tapped hole in the pedestal. Fit the locating bolt, with plain and spring washers, and tighten securely.

Clean out any oil from the cup plug counterbore in the rocker box end wall. Fit a new cup plug, coated with 'Loctite' 542, into the counter bore ensuring that the plug is pressed in squarely.

Note: The cup plug must be pressed in until it 'seats' in the counterbore.

For rocker boxes with no cup plug in the shaft bore, the procedure is basically the same as above: Position the shaft so that when it is fitted into the rocker box, the locating bolt hole will align with the tapped hole. Enter the shaft in the bore and fit the

rocker arms and springs in the correct sequence.

Before the shaft is fully in, fit one 'O' ring seal in its groove around the protruding end of the shaft. Carefully press the shaft through the bore until the groove at the opposite end is *just* clear of the rocker box wall. Fit the second 'O' ring seal and press the shaft back into its operating position. Ensure that the locating holes are aligned and fit the locating bolt, with plain and spring washers. Tighten the bolt securely.

Fitting rocker box

Check the cylinder head joint face for cleanliness and ensure that the rocker box locating dowels are fitted. Place a new gasket over the dowels and carefully place the rocker box into position.

Drop the securing setbolts and socket head capscrews into their respective holes and position the rocker adjusting screw spherical ends into the push rod sockets.

Tighten the setbolts and capscrews evenly and progressively until the correct torque loading is achieved.

Set the tappet clearances as described in Section 8, then fit the injector spill connections through the rocker box side wall, complete with new sealing washers. Tighten to the correct torque loading.

Before fitting the rocker cover, check the serviceability of the fuel injector 'O' ring seals.

Fit a new joint gasket to the rocker box top face and secure the rocker cover with the ten setbolts. Tighten the setbolts to the correct torque loading.

Fit the fuel pipework, filter header bracket and fuel filter as necessary.

**FITS AND CLEARANCES
ROCKER BOXES**

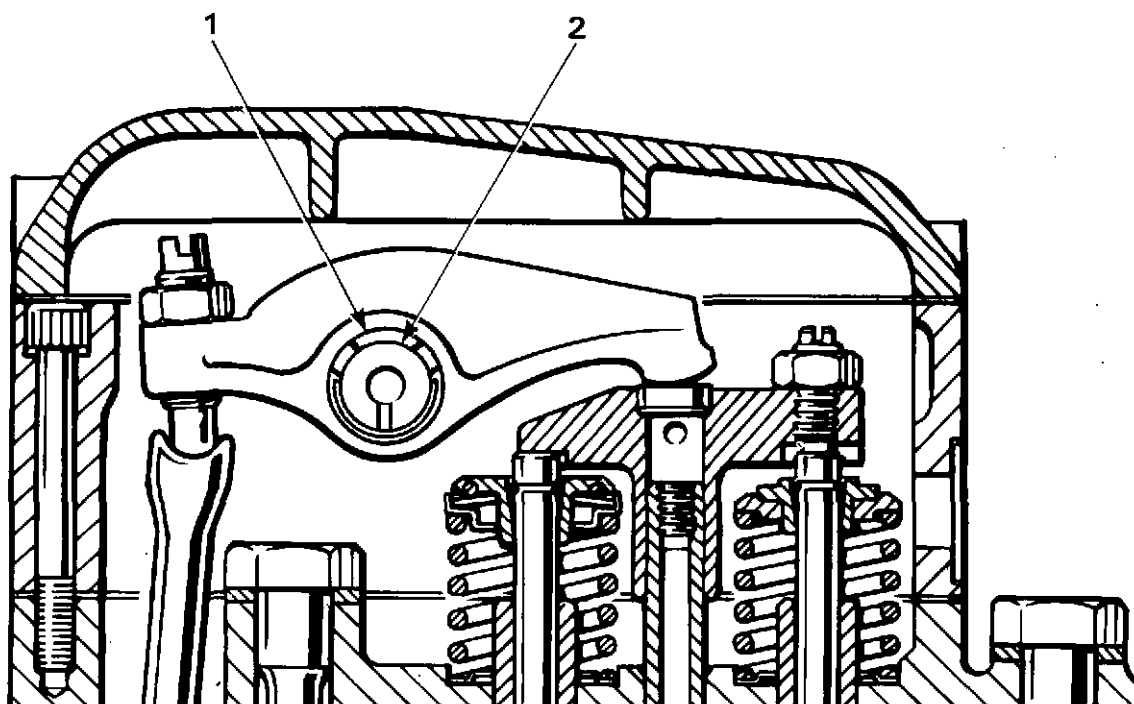

ROLLS-ROYCE DIESELS

No. ON DIAG.	DESCRIPTION	DIMENSIONS NEW		PERMISSIBLE WORN DIMENSIONS		CLEARANCE NEW		PERMISSIBLE WORN CLEARANCE		REMARKS
		mm	inch	mm	inch	mm	inch	mm	inch	
1	ROCKER ARMS Bushes in rocker arms Rocker arm bore	26.193	1.0312							
		to	to							
		26.224	1.0324			Interference 0.040	0.0015			
	Bush diameter	26.264	1.034			to	to			
		to	to			0.096	0.0037			
		26.289	1.035							
2	Rocker arms on shaft Bush bore	22.212	0.8745							
		to	to							
		22.225	0.875			0.026	0.0011			
	Shaft diameter	22.174	0.8729			to	to			
		to	to			0.051	0.0021			
		22.186	0.8734					0.13	0.005	

SECTION 10—COOLING SYSTEM

TYPICAL COOLING SYSTEM — SCHEMATIC

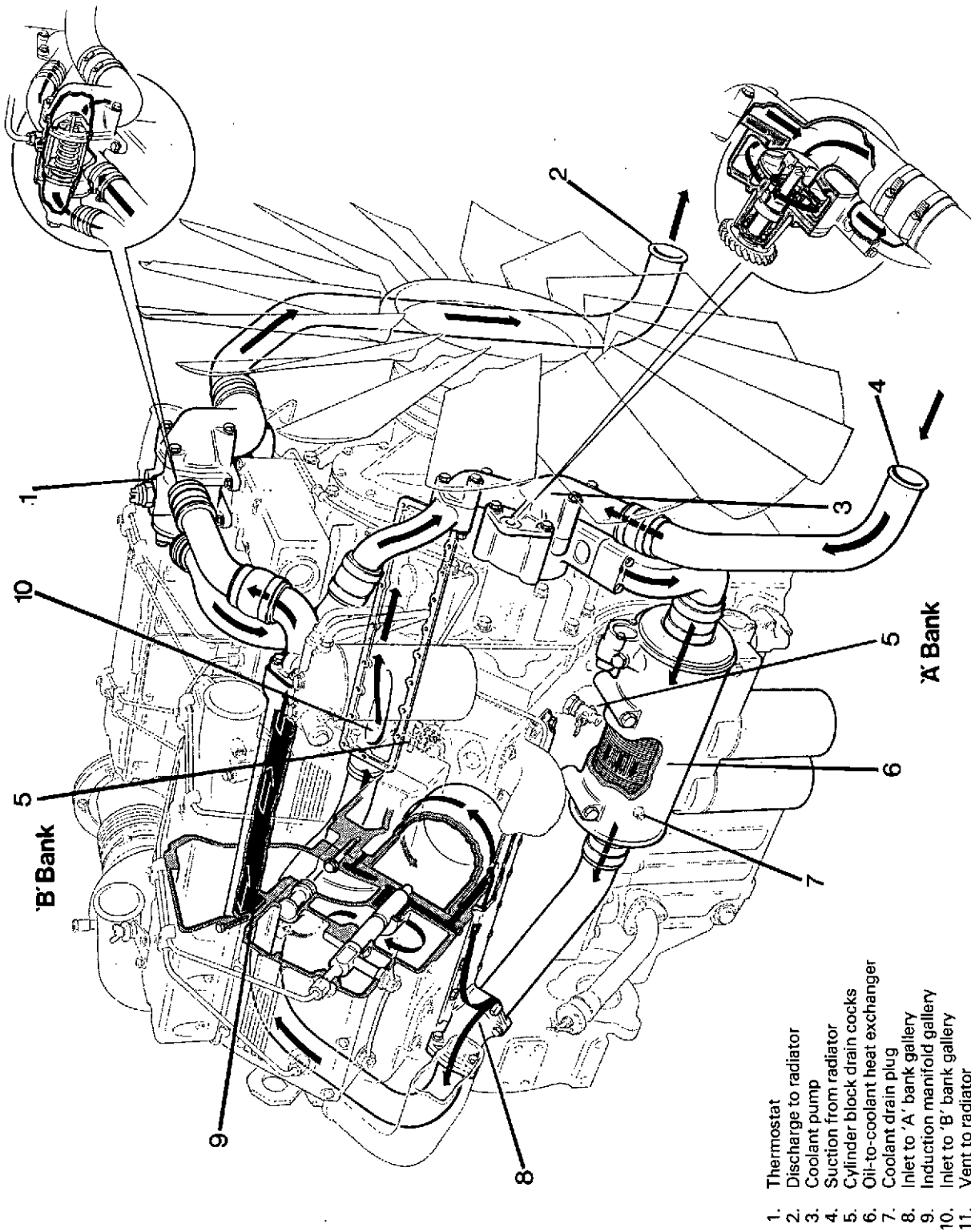

- 1. Thermostat
- 2. Discharge to radiator
- 3. Coolant pump
- 4. Suction from radiator
- 5. Cylinder block drain cocks
- 6. Oil-to-coolant heat exchanger
- 7. Coolant drain plug
- 8. Inlet to 'A' bank gallery
- 9. Induction manifold gallery
- 10. Inlet to 'B' bank gallery
- 11. Vent to radiator

FITS AND CLEARANCES
COOLANT PUMP

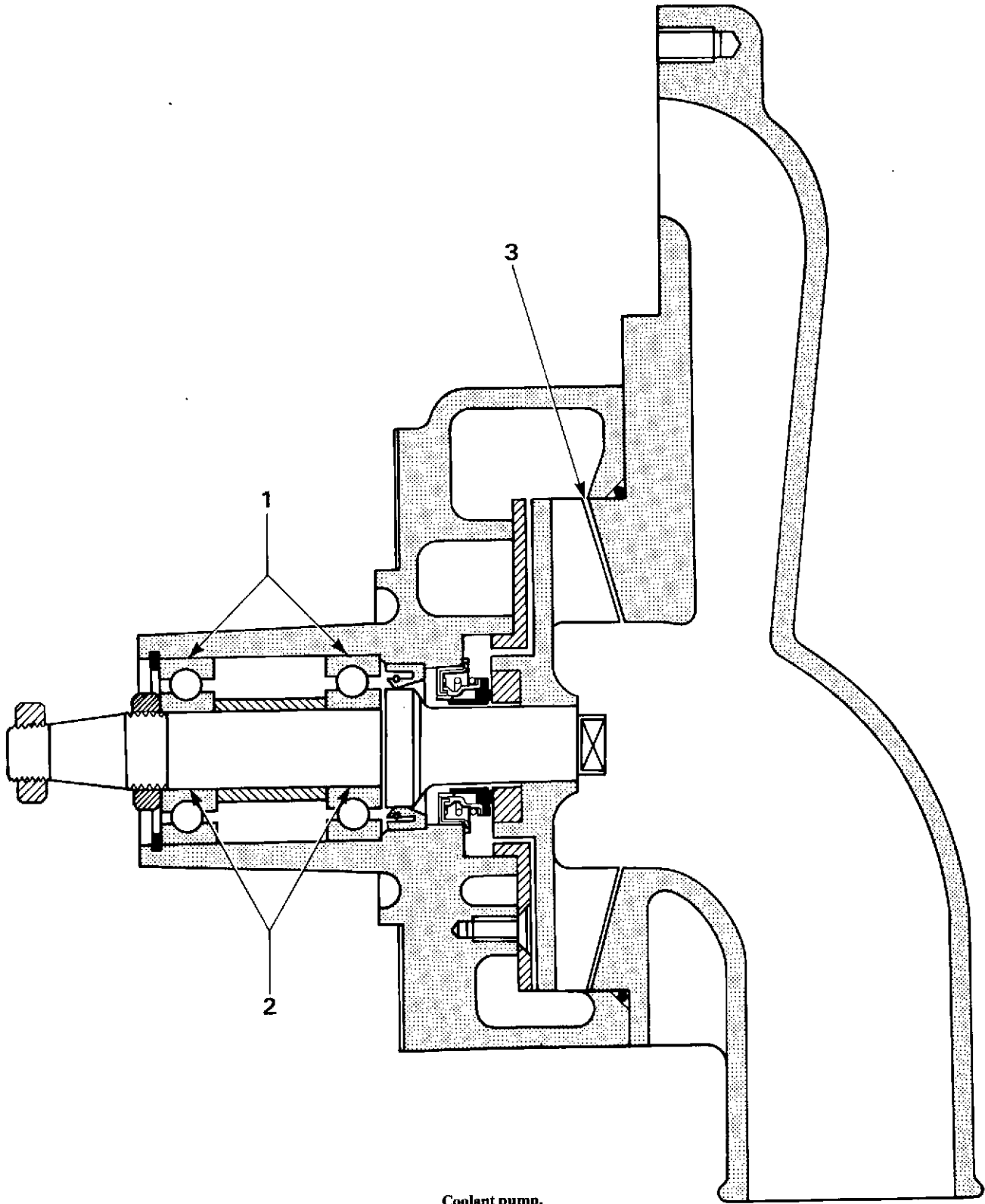

Coolant pump.

SECTION 10—COOLING SYSTEM

Description

Coolant is drawn from the base of the vertical two pass radiator by the pump and delivered to the oil-to-coolant heat exchanger situated on the 'A' bank side of the crankcase.

From the heat exchanger the coolant passes through pipework to the rear of the 'A' bank coolant gallery where a branch in the pipework divides the flow, passing half to the 'A' bank coolant gallery. The remainder is routed through external pipework around the rear of the crankcase to the 'B' bank coolant gallery.

From the galleries, coolant is directed around the cylinders, and then in to the cylinder heads.

In the cylinder heads the coolant circulates around the injector pockets, valve guides and seats, then through bobbin type connectors in the cylinder head

inner walls into galleries in the induction manifolds. Outlets at the front end of each manifold, and connecting pipework, direct the flows from both banks to the thermostat housing where the two flows merge.

If the coolant has not reached normal working temperature the thermostat valve(s) will be closed and the flow of coolant will be directed, via the by-pass port, to the coolant pump suction.

At normal working temperatures the thermostat valve(s) will be open, the by-pass port closed and the flow of coolant will be directed through external pipework to the base of the radiator.

Under normal operating conditions the cooling system will be pressurised at 50 to 70 kN/sq. m (7 to 10 lbf/sq. inch), this pressure being maintained by a pressure/vacuum relief valve incorporated in the

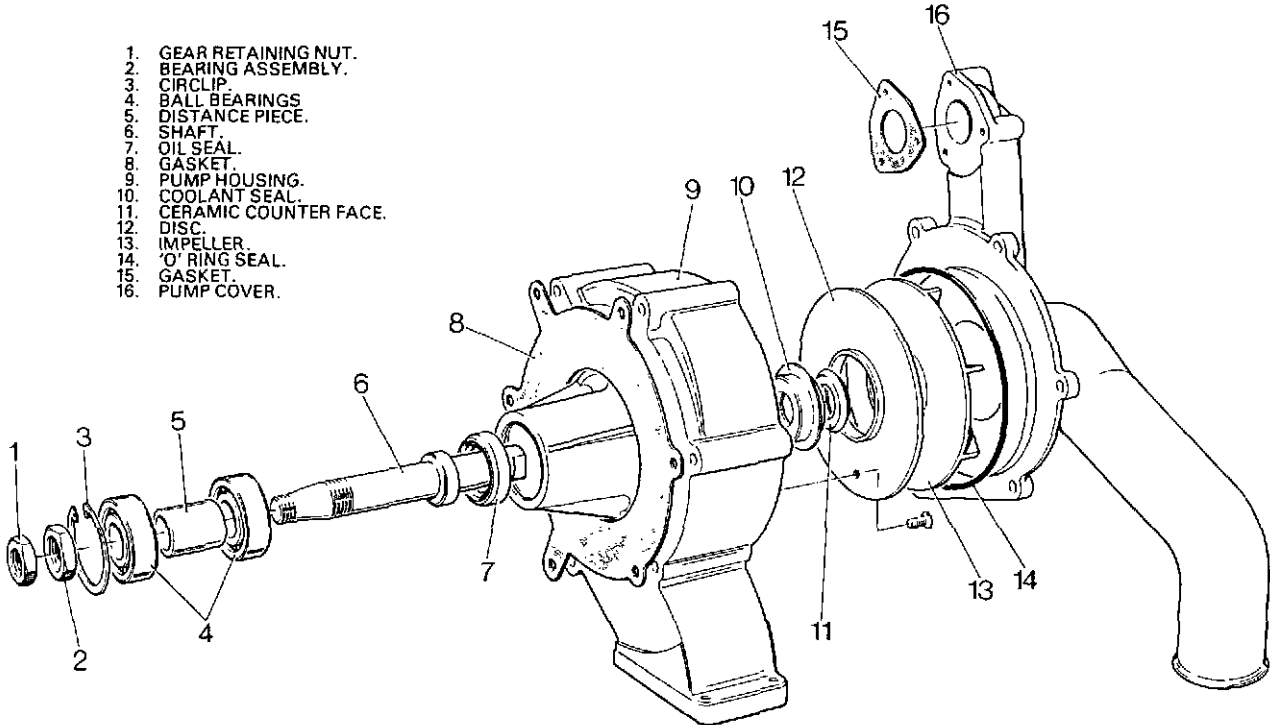

1. GEAR RETAINING NUT.
2. BEARING ASSEMBLY.
3. CIRCLIP.
4. BALL BEARINGS.
5. DISTANCE PIECE.
6. SHAFT.
7. OIL SEAL.
8. GASKET.
9. PUMP HOUSING.
10. COOLANT SEAL.
11. CERAMIC COUNTER FACE.
12. DISC.
13. IMPELLER.
14. 'O' RING SEAL.
15. GASKET.
16. PUMP COVER.

Fig. 2 Typical cooling system.

radiator filler cap.

To drain the system, drain cocks are fitted to each side of the cylinder block and drain plugs are screwed into the base of the radiator, the oil-to-coolant heat exchanger and at the lower end of the thermostat-to-radiator and coolant pump-to-radiator pipework.

COOLANT PUMP

Description

This is a conventional centrifugal pump, driven from the main gear train.

The impeller is a press fit on one end of the pump shaft. A helical cut gear is mounted on a taper at the drive end of the shaft and secured by a nut. The whole of the rotating assembly is supported on two ball races.

Lubrication of the bearings is by splash feed from the gear train via drillings connecting the bearing housing with the wheelcase. Sealing of the bearing housing is by lip type seal. The coolant seal is of the ceramic face type.

A 'tell tale' hole, drilled in the base, of the pump casing, indicates if either seal is leaking.

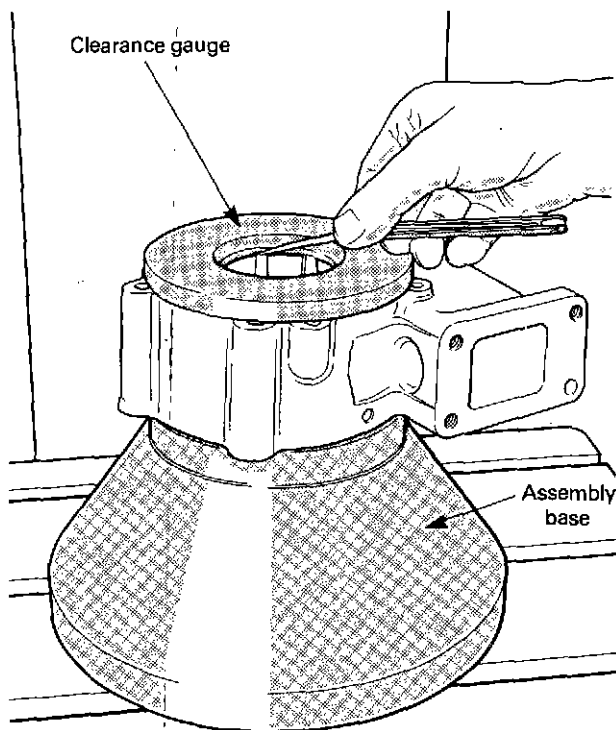

Fig. 3 Checking impeller clearance.

Removal

Before removing the coolant pump from the engine, index mark the position of the front casing relative to the pump body.

1. Drain the cooling system completely.
2. Disconnect the hose coupling the pump inlet to the base of the radiator.
3. Remove the four setbolts securing the heat exchanger pipe flange to the pump outlet, pull the flange away from the pump.
4. Remove the three setbolts securing the by-pass pipe flange to the pump, pull the flange away from the pump.
5. Remove the six setbolts securing the pump to the wheelcase and lift the pump away from the engine.

Note: It may prove necessary to release the fan belt tension to provide access to some of the pump mounting bolts.

Inspection

Carefully clean off any dirt from the impeller, pump casing and drive gear. Spin the rotor assembly and check for sounds of rubbing and for excess play in the bearings. Measure the rotor assembly end float.

Remove any traces of gasket material from the pump casing flange and wheelcase contact face. Fit the pump as detailed in Section 3, and check the gear backlash. Renew the drive gear if the backlash is beyond the permissible limits.

Check the clearance between the impeller vanes and the pump cover. On new pumps, the running clearance is between 1.0 and 1.9 mm (0.039 and 0.075 inch).

Fitting the pump

When fitting the coolant pump, renew the 'O' ring seal on the front cover and use a new jointing gasket, lightly coated with Wellseal jointing compound, between the pump and wheelcase.

Pump overhaul

During engine operation, the coolant pump normally runs trouble free, between engine overhauls. If a malfunction does occur, Rolls-Royce recommend that the Customer takes advantage of the Service Exchange Scheme to renew the unit.

For those Customers wishing to renew components in their own workshops, a series of special tools is available for the purpose, see end of Section.

No. ON DIAG.	DESCRIPTION	DIMENSIONS NEW		PERMISSIBLE WORN DIMENSIONS		CLEARANCE NEW		PERMISSIBLE WORN CLEARANCE		REMARKS
		mm	inch	mm	inch	mm	inch	mm	inch	
1	ROTOR SHAFT BALL BEARINGS									Renew if end float exceeds 0.13 mm (0.005 inch).
	Bearings in housing	46.990 to 47.003	1.8499 to 1.8505							
	Housing bore					Clearance 0.0133 to 0.0099	0.0005 to 0.0004			
	Bearing diameter	46.9897 to 46.9999	1.84999 to 1.85039			Interference				
2	Bearings on shaft									
	Bearing bore	19.99 to 20.0	0.7870 to 0.7874			Clearance 0.003 to 0.015	0.0001 to 0.0006			
	Shaft diameter	19.997 to 20.005	0.78728 to 0.78759			Interference				
3	IMPELLER									
	Running clearance					1.0 to 1.90	0.0394 to 0.075			

detergent and a small bristle brush, (ideally an old tooth brush). Check for distortion, cracks and sticking valves. Sticking valves may often be freed by applying silicone grease to the spindles and operating the valves manually to work the grease into the glands. If the thermostat appears serviceable, carry out the following tests:

Note: Silicone grease should be applied, as above, to the valve spindles of a replacement thermostat, or a thermostat fitted to an engine which is to stand with the cooling system drained. MS.4 silicone grease, manufactured by Ambersil Limited of Basingstoke, Hants, is recommended for this purpose.

Checking operating temperature

1. Mark the strap of the leading valve and place the thermostat, right way up, in a container filled with water to the level of the valve platform. Position an accurate thermometer as close as possible to the valves.
2. Heat the water, and note the temperature at which the leading valve opens sufficiently to admit a 0.05 mm (0.002 inch) feeler gauge.
3. Continue heating and, in similar fashion, note the opening temperature of the two trailing valves.
4. Continue heating and note the temperature at which each valve is fully open, i.e. when it ceases to move after opening approximately 9.5 mm (0.375 inch).
5. Compare the readings with the following limits:
 Leading valve opens : 77 to 81 deg. C.
 Trailing valves open : 81 to 85 deg. C.
 All valves fully open : 93 to 97 deg. C.

Checking operating speed

1. With all valves fully closed, immerse the thermostat, right way up, in boiling water to the level of the valve platform and note the time, after immersion, at which each valve opens sufficiently to admit a 0.05 mm (0.002 inch) feeler gauge.
2. Maintain the water at boiling point and note the time from immersion at which all valves are fully open.
3. Remove the thermostat and plunge it into cold water. Note the time taken for all valves to close fully.

4. Compare the readings with the following limits:

- Leading valve commences opening : within 15 secs.
- Trailing valves commence opening : within 20 secs.
- All valves fully open : within 60 secs.
- All valves closed in cold water : 4 to 8 secs.

Incorrect operating characteristics indicate a loss of wax. In such cases, a replacement thermostat must be fitted.

Emergency action

As with thermostat CV 301, the valves may be jacked fully open and the radiator partly blanked off as a temporary measure. Do NOT run the engine with the thermostat removed.

OIL-TO-COOLANT HEAT EXCHANGER

See Section 12, 'Lubrication System'.

SPECIAL TOOLS

Part No.	Description
VT 18066	Assembly base, coolant pump.
VT 18083	Insertion tool, volute disc.
VT 18084	Insertion tool, oil seal.
VT 18085	Insertion tool, gland seal.
VT 18087	Insertion tool, impeller.
VT 18265	Insertion tool, ball bearing.
VT 18264	Stepped base, bearings to shaft fitting.
VT 16671	Holding device.
VT 18266	Gauge, impeller clearance.
VT 12896	Extractor, oil and coolant seals.
VT 18357	Holding, fixture
VT 18327	Pressing drift
VT 18326	Spacer ring

} Impeller removal.

THERMOSTAT

Description

Early engines are fitted with a single element, wax capsule type, Western Thomson thermostat, Part Number CV 301. Later models are fitted with a triple element wax capsule type Western Thomson thermostat, Part No. OE 43404. These units are not interchangeable and in the event of thermostat failure, it is important that the correct Part Number is noted when ordering replacement units.

CV 301 thermostat

The thermostat is factory set to operate at a pre-

determined temperature and must NOT be adjusted by Operators.

In operation, the main flow valve of the thermostat begins to open when the coolant temperature reaches 68 to 73 deg. C. and the by-pass valve begins to close a corresponding amount. The normal working travel of the main flow valve is 12.7 mm (0.5 inch) which is achieved at a temperature of 78 to 83 deg. C. When this temperature is reached, the by-pass valve is fully closed ensuring that the full flow of coolant passes through the radiator. At higher temperatures the main flow valve will open to a maximum of 23.8 mm (0.937 inch), the extra travel being taken up by compression of the by-pass valve spring.

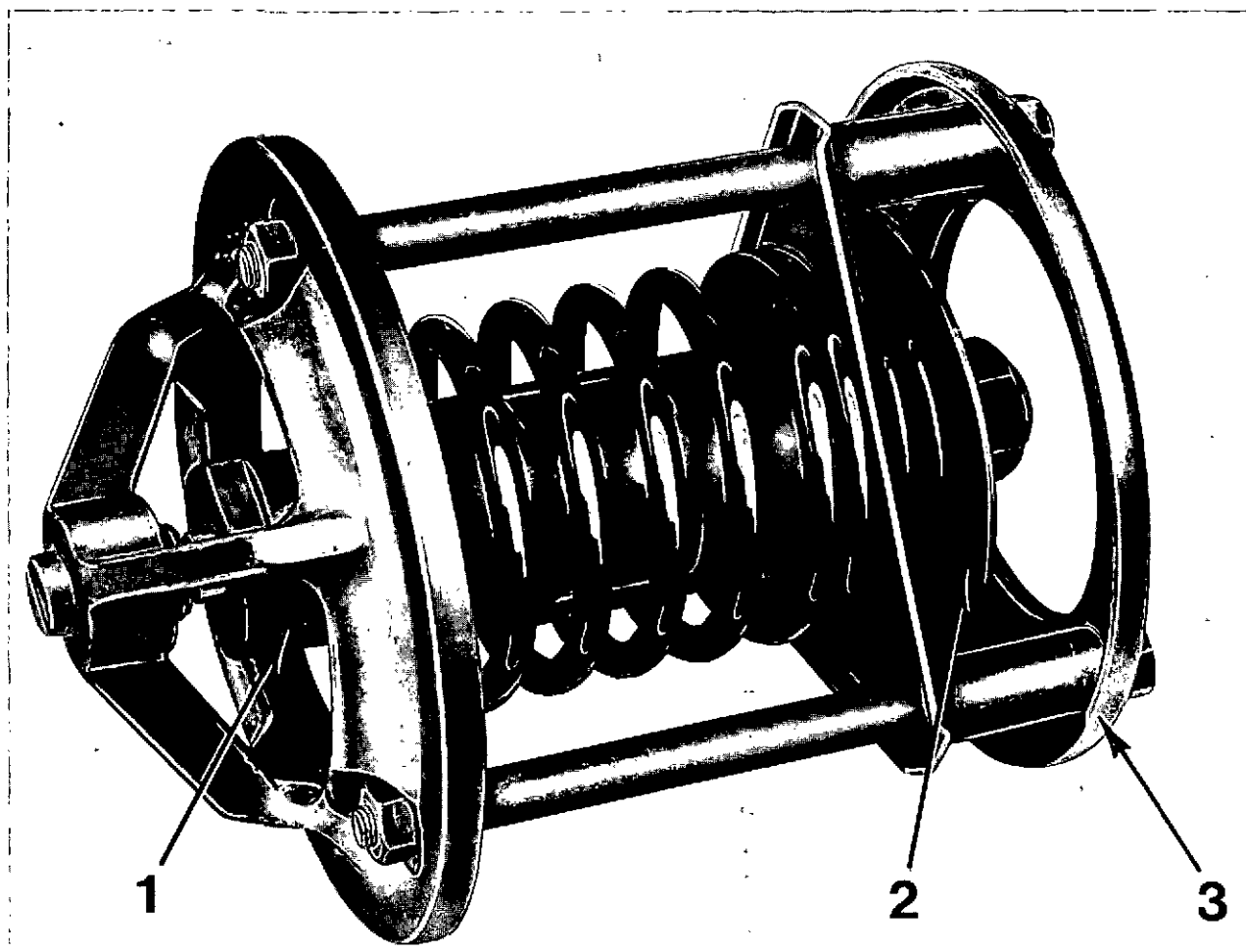

Fig. 4 Thermostat CV 301.

1. Main flow valve opening 2. By-pass valve 3. By-pass valve seat

Inspection

To check the operating characteristics of a thermostat, drain the coolant to below the level of the thermostat housing, release the discharge hose connection, remove the housing cover and withdraw the thermostat unit.

Thoroughly clean the thermostat using a bristle brush and mild detergent. Check for distortion, cracks, damage and sticking valves. A sticking valve may often be remedied by applying silicone grease to the spindle and operating the valve manually to work the grease into the gland. If the thermostat is apparently serviceable, carry out the following tests:

Place the unit in a tank containing water at a constant 20 deg. C. for 5 minutes, then plunge the unit into a tank of water at a constant 100 deg. C. Note the time taken for the valve to open sufficiently to admit a 0.05 mm (0.002 inch) feeler gauge; this should be between 30 and 40 seconds. Note the time taken for the valve to open 12.7 mm (0.5 inch); this should be between 90 and 120 seconds. Finally plunge the unit into a tank containing water at 20 deg. C. and note the time taken for the valve to close completely; this should be between 25 and 35 seconds.

The thermostat is extremely reliable, so incorrect operating characteristics indicate a loss of wax. In such cases the unit must be renewed.

Check the condition of the discharge hose connection and renew if necessary. Refit the housing using a new gasket lightly coated with jointing compound and top up the system with the approved coolant mixture.

Emergency action

If a replacement thermostat is not available it will be necessary, as a temporary measure only, to jack the valves fully open and run the engine with the radiator partly blanked off. In no circumstances should the engine be run without a thermostat, since the by-pass ports would then be permanently open, causing over-heating.

OE 43404 thermostat

The triple element thermostat is located in its housing by a rollpin which ensures that each element is directly above its by-pass port. As each valve opens, the corresponding port closes thus directing the coolant flow to the radiator.

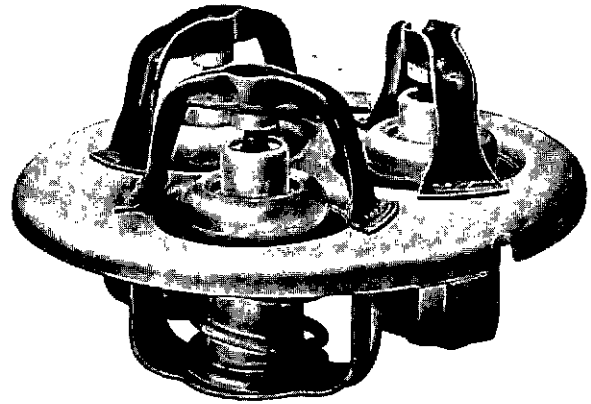

Fig. 5 Thermostat OE 43404.

The opening temperatures differ slightly between the leading valve and the two trailing valves. A nominal operating temperature figure, in degrees C. is stamped on the base of each element.

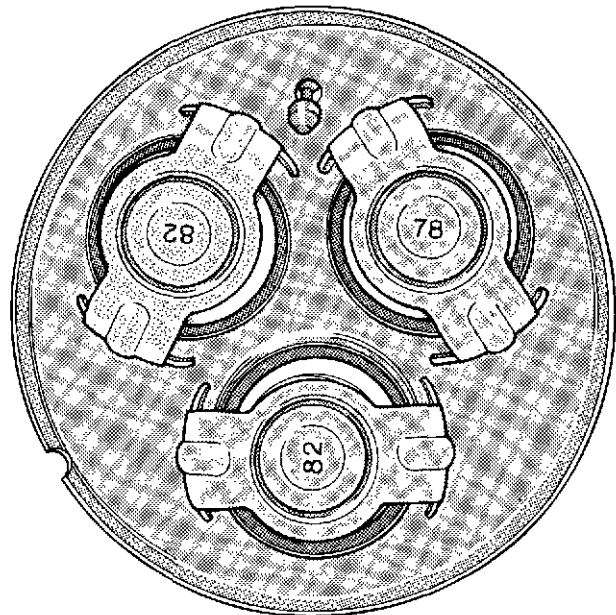

Fig. 6 Operating temperature figures.

Inspection

To remove the thermostat, drain the coolant to an adequate level, disconnect the top hose, remove the housing cover and withdraw the thermostat.

Thoroughly clean the thermostat using a mild

SECTION 11 — FUEL SYSTEM

PART 1 — INJECTION PUMP

PART 2 — GOVERNOR — BOSCH

PART 3 — FEED PUMP

PART 4 — TEST INSTRUCTIONS

PART 5 — GOVERNOR — AMBAC

PART 6 — FUEL INJECTORS

The contents of this section are based on information supplied by courtesy of Robert Bosch GmbH, Stuttgart, West Germany.

IMPORTANT

Repair and overhaul work on injectors, pumps and governors should only be undertaken by suitable trained and equipped personnel, working in conditions which conform to a high standard of order and cleanliness. If these requirements cannot be met, the faulty or life-expired unit should be exchanged for one which has been reconditioned and tested at the Factory.

TYPICAL FUEL SYSTEM — SCHEMATIC

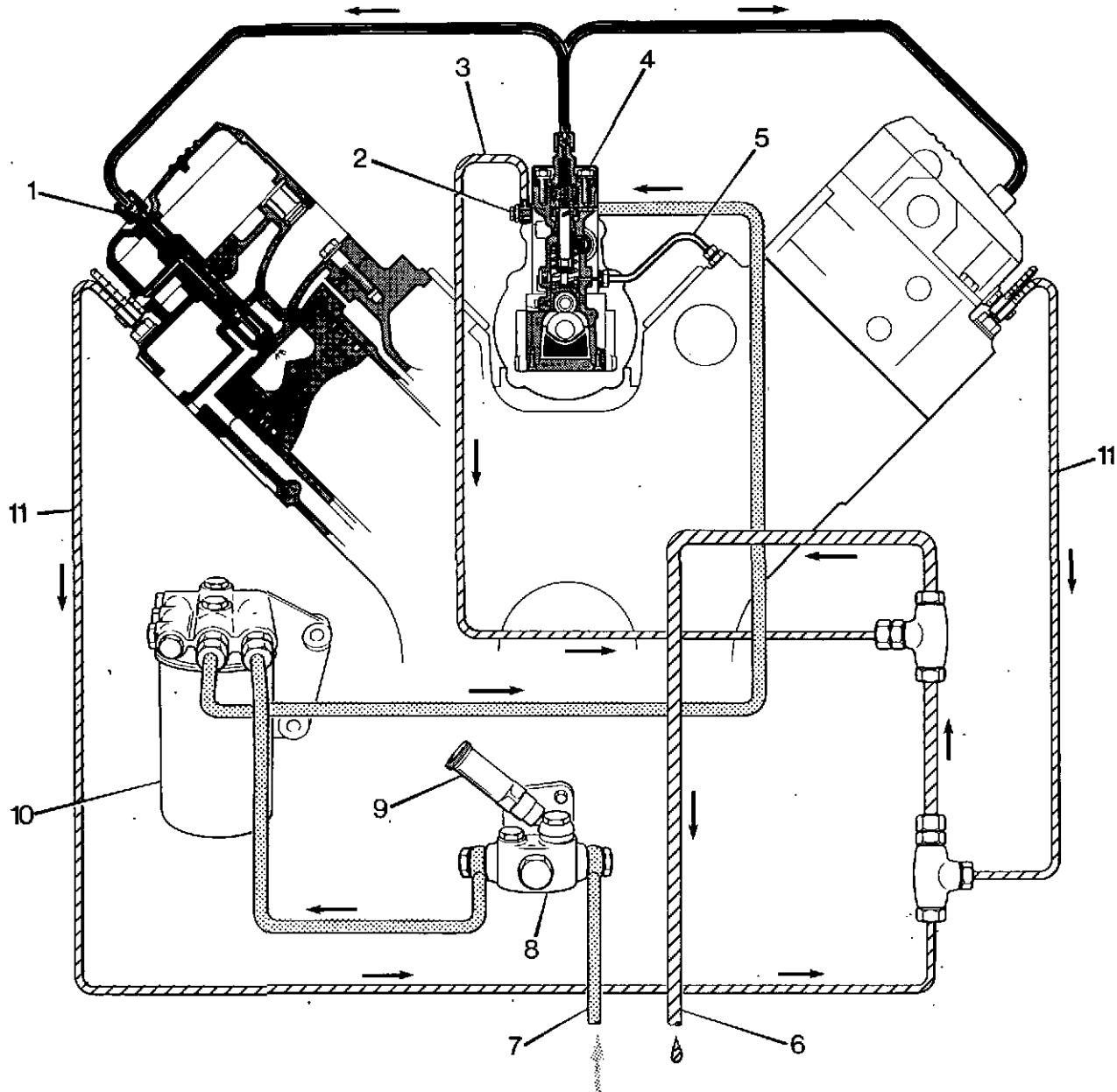

- 1. Fuel injector
- 2. Low pressure relief valve
- 3. Excess fuel return
- 4. Fuel injection pump
- 5. Lubricating oil supply

- 6. Spill return to supply tank
- 7. Suction from supply tank
- 8. Fuel feed pump
- 9. Hand priming plunger
- 10. Main filter canister

- 11. Injector spill return
- - High pressure fuel
- ⋯ - Low pressure fuel
- ▨ - Spill return to tank
- - Lubricating oil

SECTION 11 — FUEL SYSTEM — BOSCH 'PE' PUMP AND ACCESSORIES

PART 1 — INJECTION PUMP, TYPE 'PE'

NOTE: Although some illustrations in the following text depict a 6-element pump, the operations and essential details apply equally to the 8-element unit.

DISMANTLING

1. It is important to provide adequate storage trays, those for paired or associated assemblies such as pumping elements and tappets being divided into numbered compartments to enable each assembly to be kept together.
2. Thoroughly clean the unit, and drain the lubricating oil by removing the feed pump and governor access cap.
3. Mount the pump on a suitable rig, such as the swivel vice 0 681 240 048 shown in fig. 2. Remove the rear cover and dismantle the governor as described under 'DISMANTLING' in Part 2.
4. Invert the pump and remove the bottom plate.
5. Referring to fig. 3, remove the eight tappet access screws from the pump casing. In turn, bring each tappet to TDC and fit a holder 1 681 115 12F to lift and retain the tappet clear of the cam lobe. To do this, proceed as follows, dependent on the pump stroke:
On 12 mm and 13 mm bore pumps, screw in the element and guide sleeve by hand and then finally tighten one turn using a spanner. Fit the capscrew by hand until the element reaches the tappet and then use an Allen key to tighten it half-a-turn further. Do NOT exceed this or the element may foul the cam.
6. Invert the pump and remove the camshaft centre bearing, which is retained by two socket screws (fig. 4).
7. Turn the pump upright and remove the screws securing the drive end bearing plate. Referring to fig. 5, fit supporting bracket 1 682 329 011 and withdraw the bearing plate by using a claw

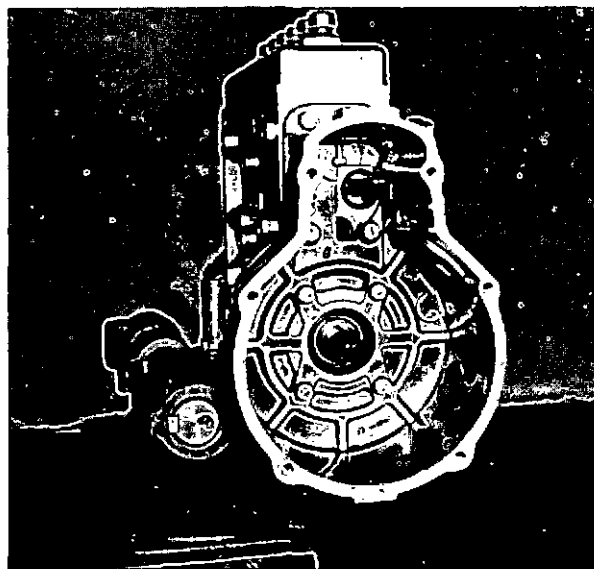

Fig. 2 Pump on swivel vice.

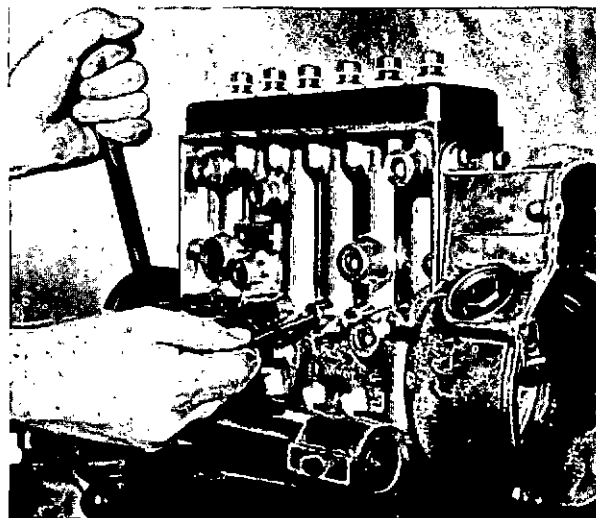

Fig. 3 Fitting tappet holders.

extractor engaged in the recesses provided. The supporting bracket is necessary to avoid transferring load to the opposite end bearing via the camshaft. Remove the 'O' ring and shims from the end plate recess.

8. Withdraw the camshaft (fig. 6).
9. Remove the governor housing and adjusting plate from the opposite end (fig. 7).
10. Invert the pump, fit element spring compressing tool 1 688 110 027, together with pivot bar 1 683 001 003 and, on each tappet in turn, push the roller down; remove the tappet holder and unload the plunger spring (fig. 8).
11. Withdraw the roller tappets (fig. 9), use a wire hook to lift out the spring plate and pump plungers (fig. 10) and take out the plunger springs (fig. 11). Place each assembly in the appropriate compartment of its storage tray.
12. Set the control rack to mid-position and remove the control sleeves and upper spring plates (fig. 12).
13. Unscrew the smoke stop or excess fuel device assembly, together with its adaptor, from the drive end.
14. Using pin spanner 1 687 950 075, unscrew the threaded bush (fig. 13) and pull out the control rack and its dowel pin. Remove the control rack guide at the drive end by means of a wire hook and then use a long drift to tap out the guide at the governor end.
15. Turn pump upright and remove the top cover. Unscrew the nuts securing the delivery valves and remove their washers. Extract the delivery valves, using tool 1 688 110 026 (fig. 14), ensuring that each assembly is stored in the same compartment as its associated components removed in Operation 11. Remove any packings which may have remained in the housing (fig. 15).
16. Remove the circlip, baffle sleeve and 'O' ring from pump barrel. Remove 'O' ring, nylon ring and phasing shims from delivery valve flanged bush. Using mounting device 1 682 310 031 and ring spanner 1 687 950 525 (fig. 16) unscrew the connector from the flanged bush and remove the spring, delivery valve and washers.

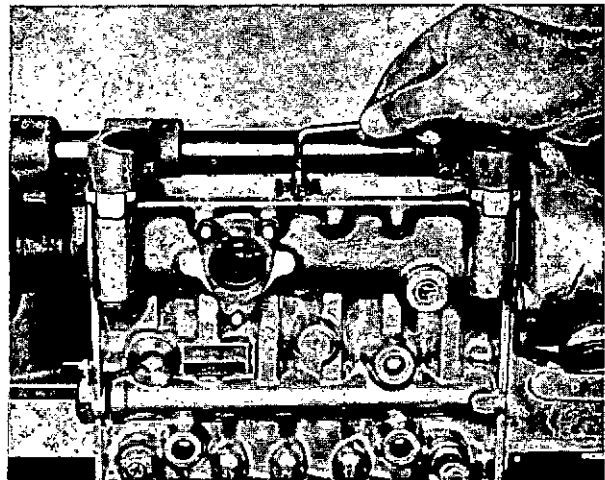

Fig. 4 Removing centre bearing.

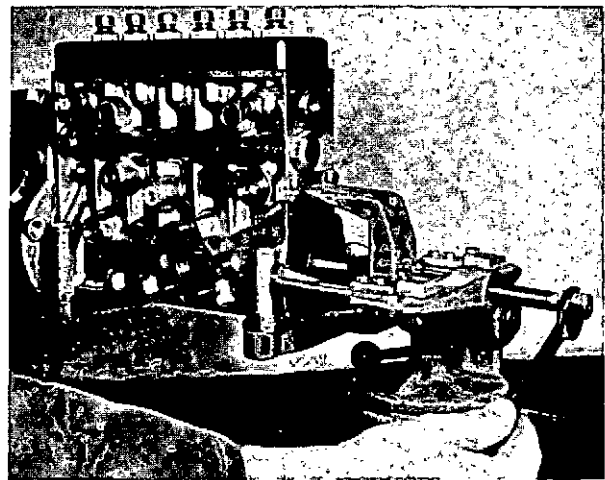

Fig. 5 Withdrawing drive end bearing plate.

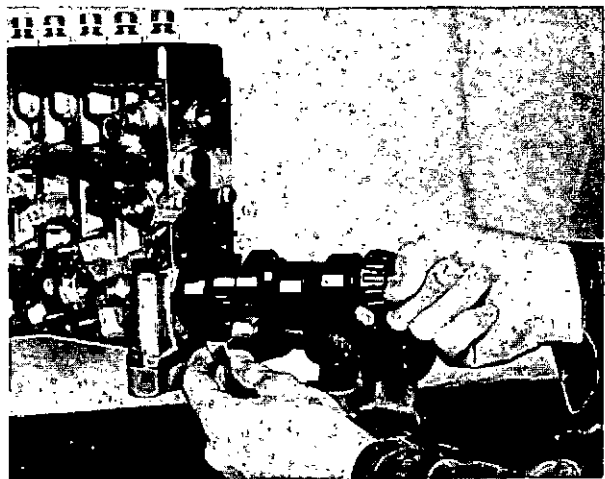

Fig. 6 Removing camshaft.

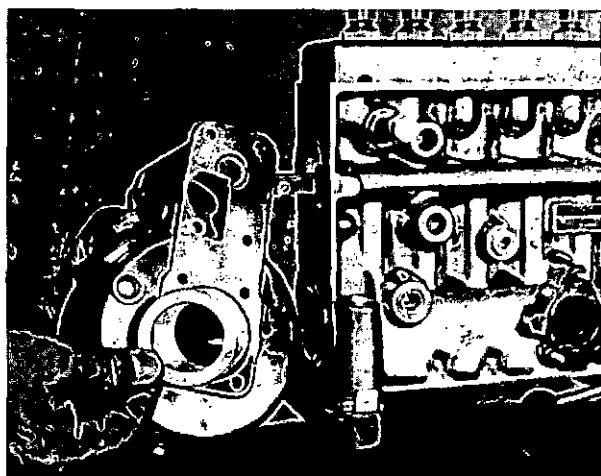

Fig. 7 Removing governor casing and adjusting plate.

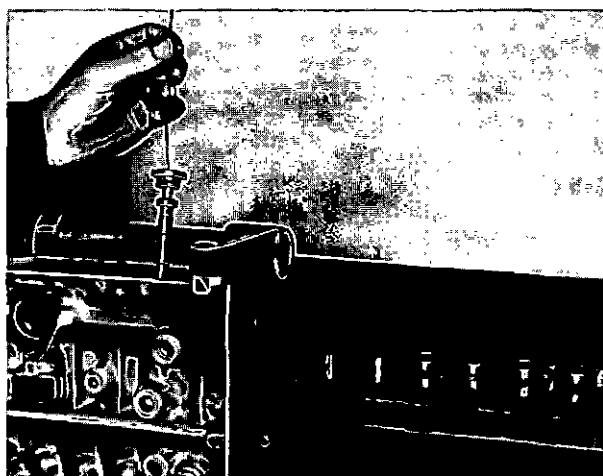

Fig. 10 Withdrawing plunger and lower spring plate.

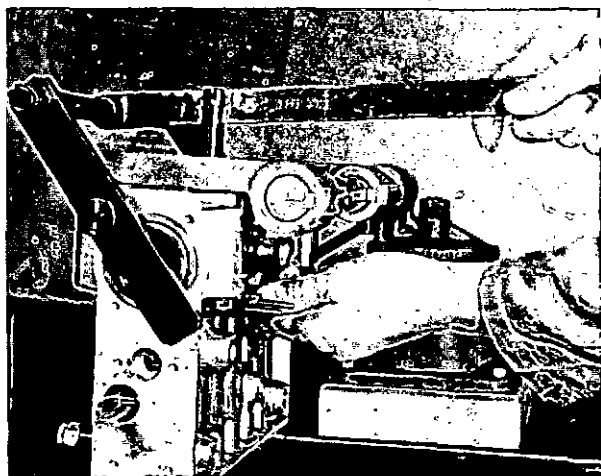

Fig. 8 Unloading plunger springs.

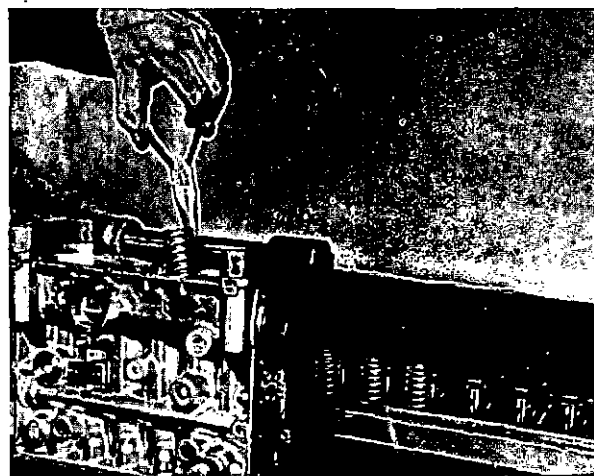

Fig. 11 Extracting plunger springs.

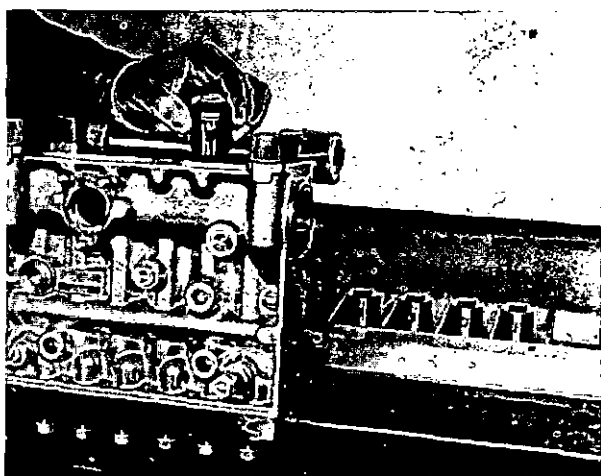

Fig. 9 Removing tappets.

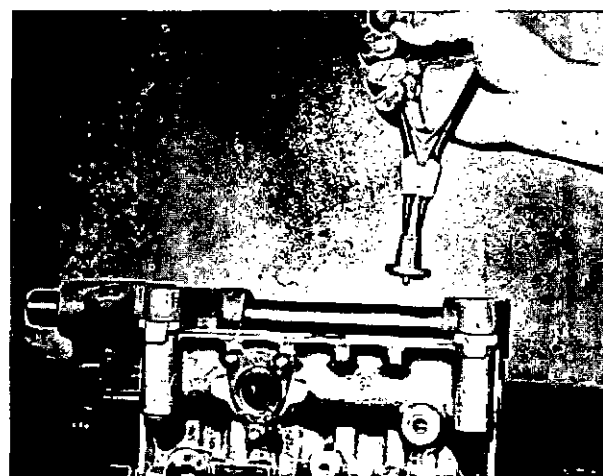

Fig. 12 Removing control sleeves and upper spring plates.

CLEANING AND INSPECTION

Remove and discard all seals, joints and 'O' rings. Clean all parts in petrol or paraffin, using a soft brush, and dry them with a compressed air jet. Do NOT use cloth or rag for this purpose. Ensure that paired or associated components remain together.

Element plungers and their barrels must not be deeply scored, and the plunger helices should have clean sharp edges. If a plunger or barrel are unserviceable both components must be replaced by a mated assembly. Similarly, the delivery valve collar should not be deeply grooved and its face and seating must be unworn; these items must also be renewed as an assembly even if only one is unserviceable. When reconditioning a pump after prolonged service it is advisable to renew all pumping element and delivery valve assemblies as a matter of routine, thereby simplifying adjustment on the test rig and ensuring long-term reliability.

Inspect all other components for wear and damage, replacing them where necessary. Pay particular attention to cam lobes, tappet rollers, bearings and the ball notches in the control rack.

ASSEMBLING

1. Check camshaft projection as follows:
 - (a) Remove bearing outer race at governor end (fig. 17). Then press it in again until it protrudes 3 mm (0.118 inch), as shown by dimension 'a' in fig. 18.
 - (b) Place the adjusting plate on the outer race, fit the joint washer and governor housing and lightly tighten the securing screws. Then press the assembly fully home (fig. 19) and fully tighten the securing screws.
 - (c) Insert the camshaft, complete with front and rear bearings but without centre bearing. Fit drive end bearing plate with same shims as found during dismantling, but omitting the 'O' ring, and tighten the retaining screws firmly. Press measuring bar 1 682 310 018 on to the camshaft taper and measure the clearance between bar and pump housing (fig. 20). Limits are 13 to 14 mm (0.512 to 0.551 inch). If below limits, fit an appropriately thicker adjusting plate at the governor end and press the

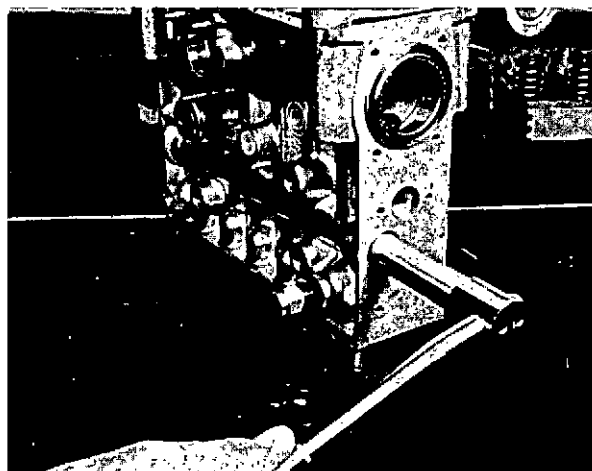

Fig. 13 Unscrewing threaded bush.

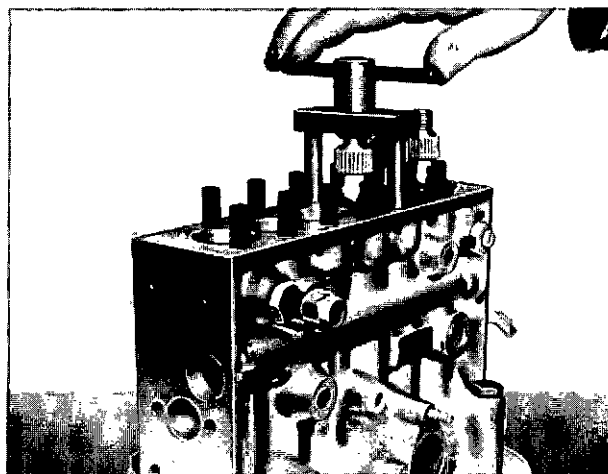

Fig. 14 Extracting delivery valve.

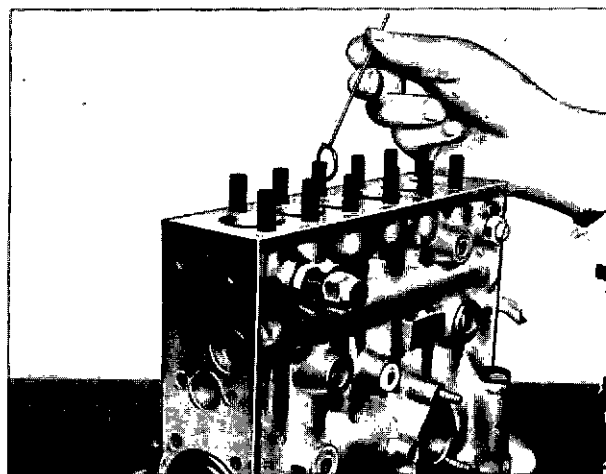

Fig. 15 Removing packings from housing.

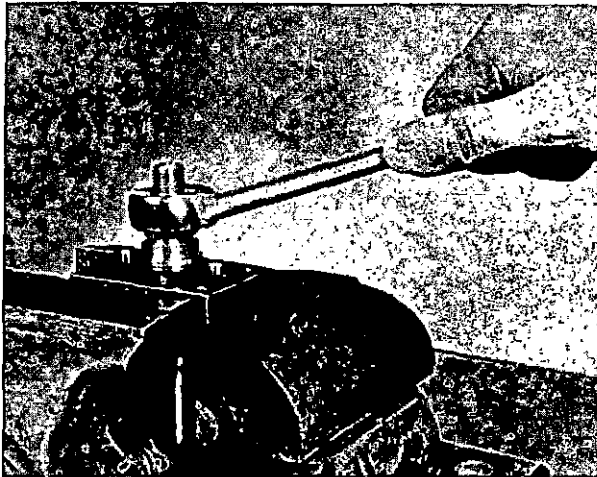

Fig. 16 Dismantling barrel/delivery valve assembly.

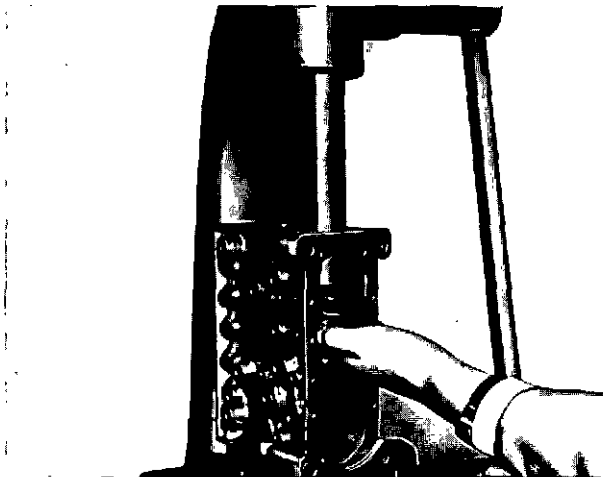

Fig. 17 Removing outer race from governor end.

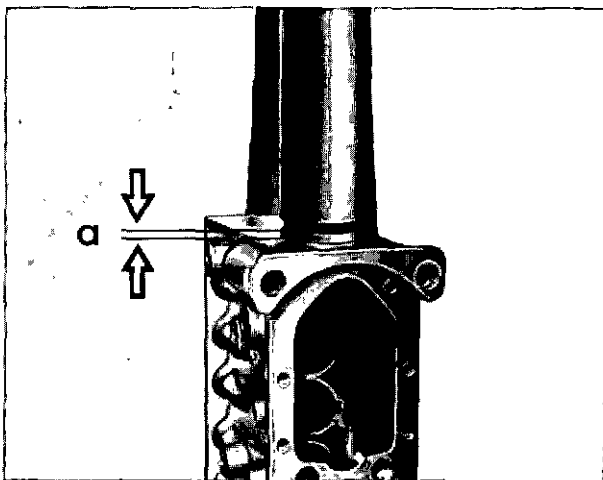

Fig. 18 Re-positioning outer race (first operation).

outer race further in, as in (b), page 6. If above limits, repeat (a) and (b) using an appropriately thinner adjusting plate.

- (d) When the projection is correct, remove the governor housing, adjusting plate and camshaft.
2. Assemble the barrel/delivery valve assemblies as follows:
 - (a) Using mounting device 1 682 310 031 clamped in a vice, refer to fig. 21 and fit flange bushing (1); then insert pump barrel (2) so that the notch on its collar engages with the peg inside the flange bushing (the barrel must drop into position under its own weight). Assemble delivery valve (3), joint (4), spring (5) and washer (6). Fit 'O' ring (7) to connector (8) and screw the latter into the flange bushing (1). Finally, torque-tighten the connector to between 69 and 70 Nm (51 and 58 lbf. ft.) using socket 1 687 950 062 (fig. 22).
 - (b) Refer to fig. 23 and slide washer (4) on to pump barrel (8) until it abuts against flange bushing (9); then assemble baffle sleeve (3), with its offset radial drillings away from flange bushing (9), and fit circlip (2). Finally, fit Viton ring (1) to the lower groove of the pump barrel.

Note: Do not confuse this Viton ring with the rubber 'O' ring of similar size fitted to the pump casing bore. Distinguishing features are that the Viton ring is greyish in colour and slightly harder to compress. Fig. 24 shows the rubber ring 'a' and Viton ring 'b' under equal radial pressures.

Again referring to fig. 23, the 'O' ring (5), nylon ring (6) and phasing shim (7) are not fitted until the barrel/delivery valve unit is assembled to the pump housing (Operations 4 and 5).

3. Using tool 1 688 110 028, fit a rubber 'O' ring, see **Note** in 2 (b), to each bore (fig. 25). Depress tool plunger, fit a greased ring, enter tool fully into bore and release plunger.
4. Fit a greased 'O' ring, nylon ring and shim (fig. 23, Items 5, 6 and 7) to each port (fig. 26). **Note:** On pumps with numbers prefixed '626' and later the nylon ring is superseded by a steel

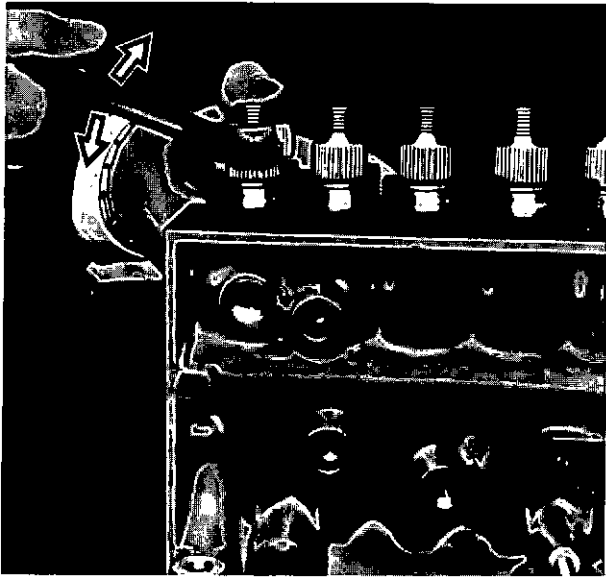

Fig. 28 Easing assembly into place.

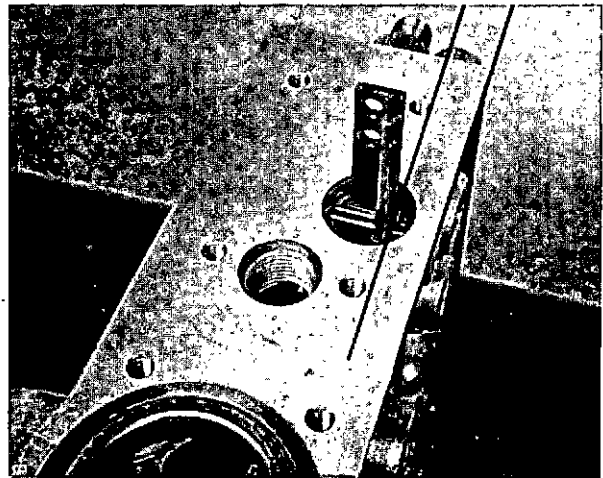

Fig. 31 Alignment of control rack.

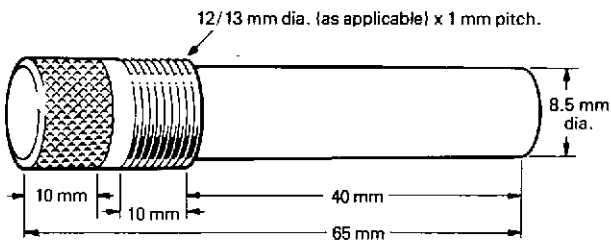

Fig. 29 Plunger retaining pin for pressure test.

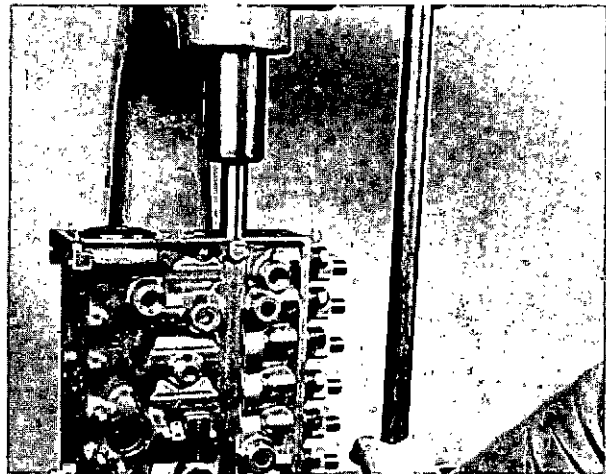

Fig. 32 Pressing in guide block.

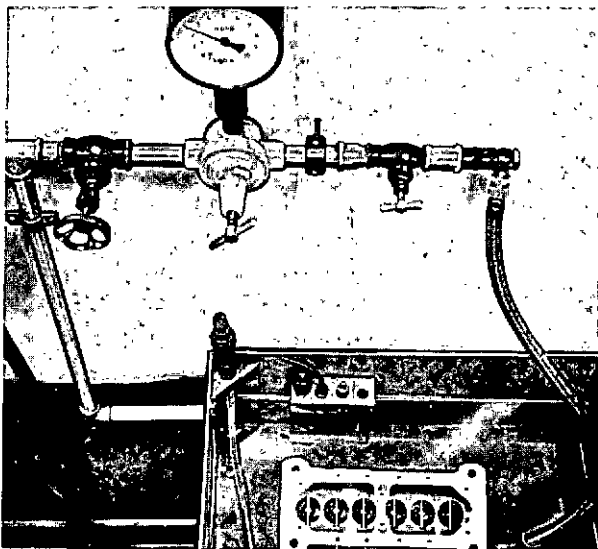

Fig. 30 Pressure test.

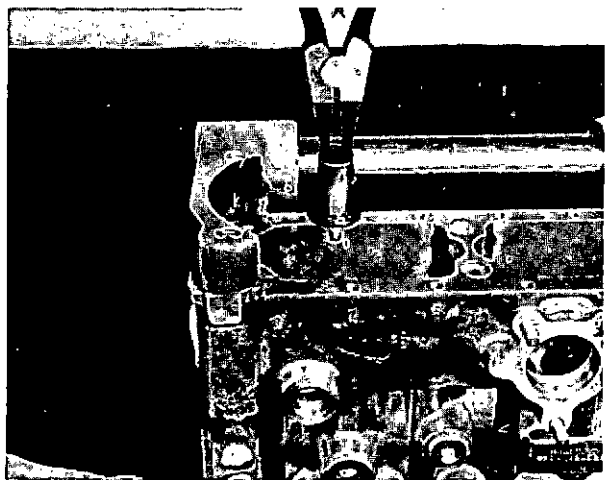

Fig. 33 Fitting control sleeves.

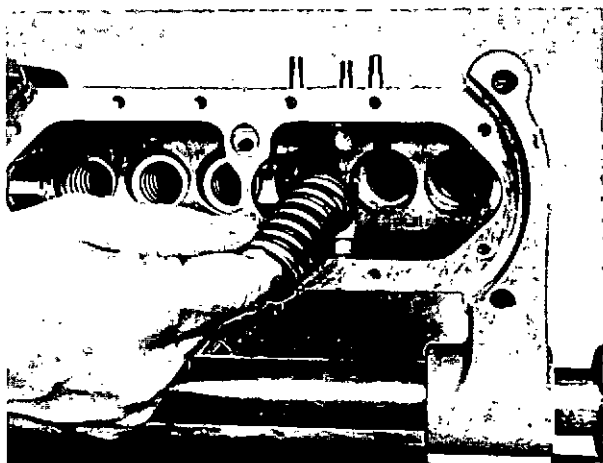

Fig. 34 Inserting upper plate and plunger spring.

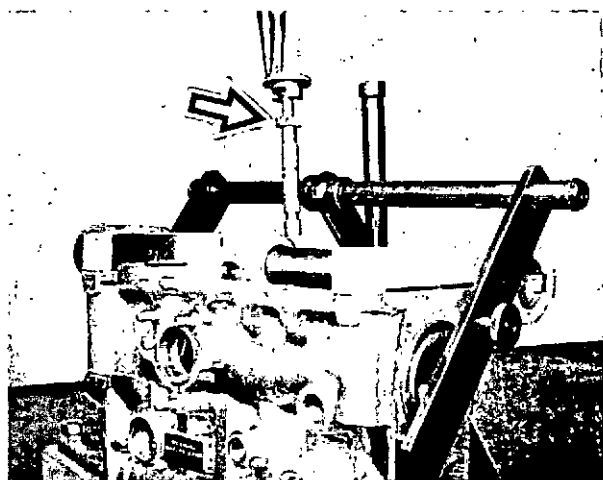

Fig. 35 Fitting plunger and lower plate.

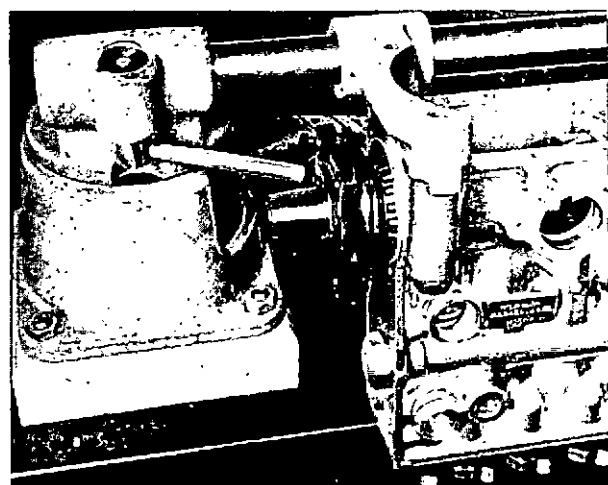

Fig. 36 Assembling drive end bearing.

11. Set the control rack to mid-position (i.e. with control sleeve notches in line with tappet guides) and fit the control sleeves (fig. 33), ensuring that in each case the driving ball is engaged with the rack notch. Check that the rack has free and full movement.
12. Insert the upper spring plates and plunger springs (fig. 34).
13. Fit spring compressing tool 1 688 110 027 and pivot bar 1 683 001 003 to the pump housing. On each element in turn:
 - (a) Fit the lower spring plate to its plunger and insert the assembly into its barrel (see fig. 35) with the line on the plunger towards the rack, as indicated by the arrow.
 - (b) Assemble the tappet, compress its spring and use holder 1 681 115 12F to retain it until the camshaft has been fitted. Screw the element and guide sleeve, without the capscrew, fully into the access tapping. Then fit the capscrew, tightening it until the tappet roller is 64.2 mm (2.527 inches) from the lower joint face of the pump casing.
14. Fit the governor housing and joint washer, together with the appropriate adjusting plate as determined in Operation 1. Enter the camshaft from the drive end and fit the centre bearing tightening its two socket screws to between 8 and 9 Nm (5 to 6.5 lbf. ft.). Assemble the drive end bearing plate with shims, but omitting the 'O' ring (fig. 36).
15. Measure the camshaft end float by using tool 0 681 440 013, screwed on to the drivenut thread, and dial gauge 1 687 233 011, as shown in fig. 37. Limits are 0.02 to 0.06 mm (0.008 to 0.024 inch). Adjust if necessary by varying the shims beneath the bearing plate. Fit the 'O' ring when finally assembling the bearing plate.
16. Using a new joint gasket, fit the base cover plate.
17. Turn the pump upright. In turn, bring each tappet to TDC and unscrew the tappet holder 1 681 115 12F (fig. 38). When all tappet holders are removed, fit the blanking screws to the tappet access holes.
18. Fit the feed pump. Assemble the governor as described in Part 2, prime the unit with engine lubricating oil, and carry out Test Procedure as described in Part 4.

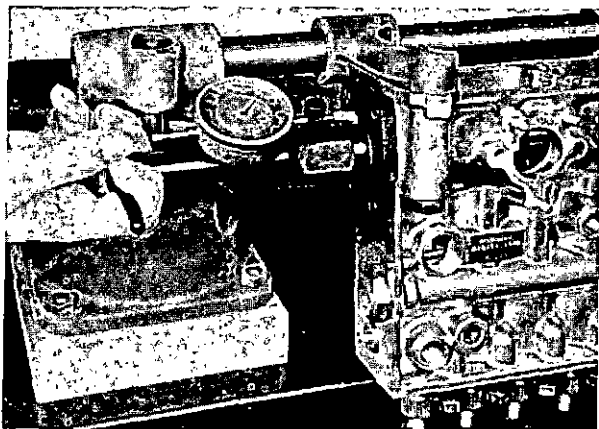

Fig. 37 Checking camshaft end float.

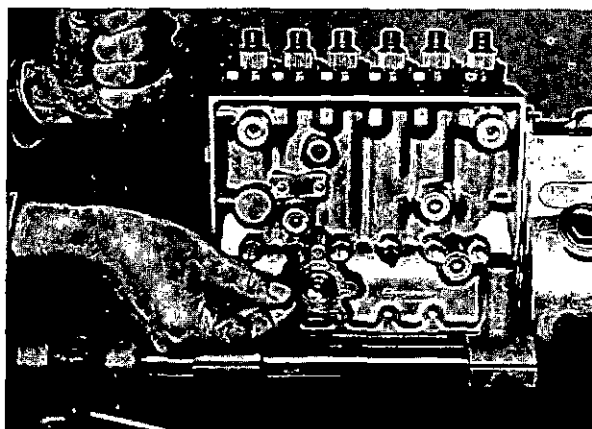

Fig. 38 Removing tappet holders.

SPECIAL TOOLS — BOSCHE 'PE' PUMP

Bosche Part No.	Description
0 681 240 048	Swivel vice
1 682 310 031	Mounting device, element
1 687 950 062	Spanner, socket, delivery valve connector
1 688 110 026	Extractor, element
1 680 363 001	*Extractor, governor flyweights
1 687 950 525	Spanner, open ring, delivery valve connector
1 681 115 12F	Tappet holder (one per element)
1 687 950 064	*Spanner, governor nut
1 688 110 027	Compressing tool, element springs
1 683 001 003	Pivot bar, adapting 1 688 110 027 for 8-element pumps
1 682 310 018	Measuring bar, camshaft position
1 688 110 028	Inserting tool, 'O' rings in pump bores
1 687 950 075	Spanner, pin, threaded bush
0 681 340 003	Pliers, plunger inserting
1 682 329 011	Bracket, camshaft bearing plate extractor
1 688 130 019	Measuring tool, camshaft end float, less dial gauge
1 687 233 011	†Dial gauge for 1 688 130 019

*Also listed in 'SPECIAL TOOLS, BOSCH RQV GOVERNOR,' Part 2 of this Section.

†Also listed in 'Special tools, Test Procedure,' Part 4 of this Section.

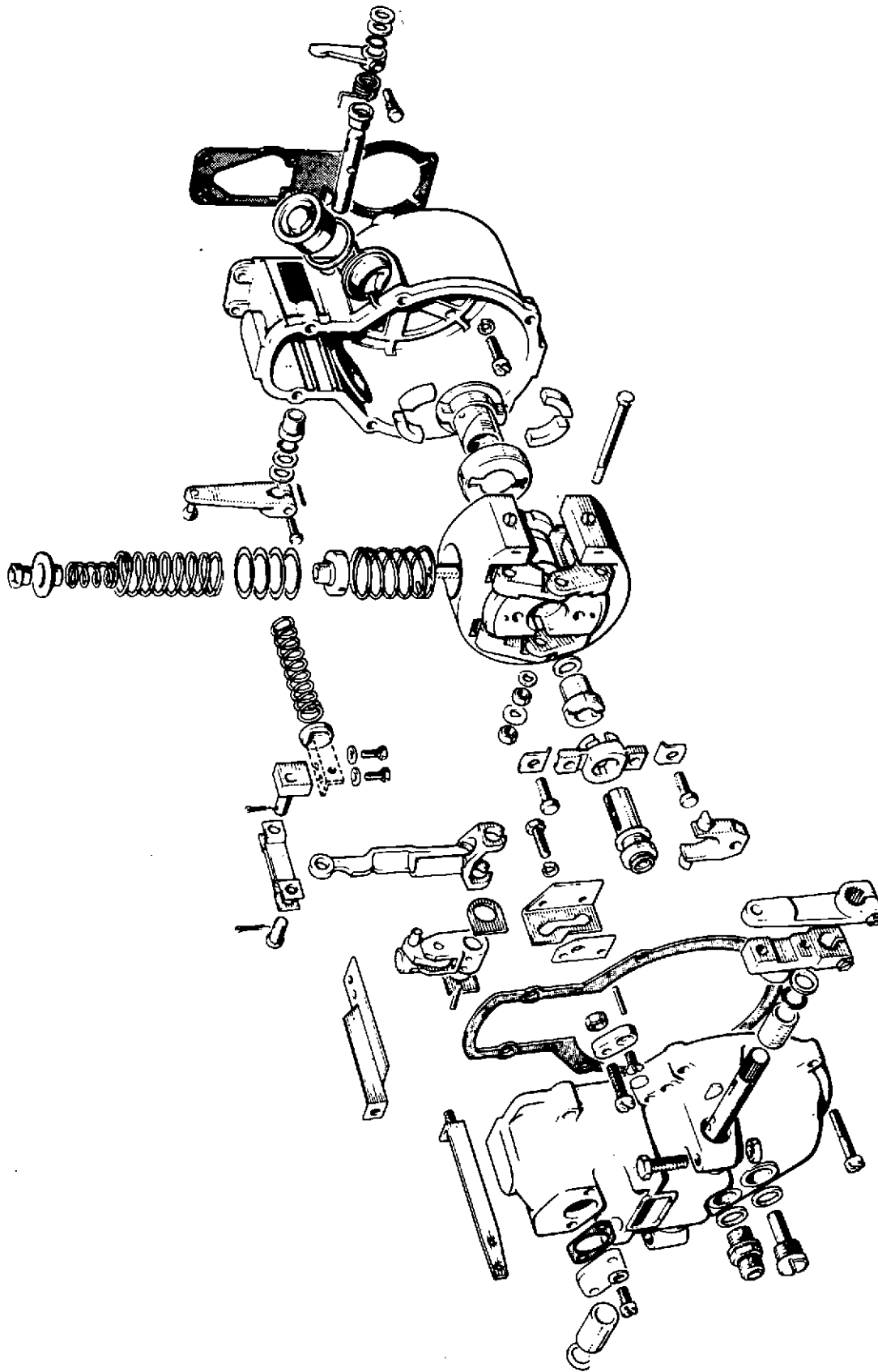

Fig. 39 Governor, exploded.

PART 2 — GOVERNOR, TYPE RQV

As explained and illustrated early in Part 1, the governor is best dismantled when it and the injection pump have been drained of lubricating oil (by removing the filler plug) and mounted on a suitable rig, such as the swivel vice 0 681 240 048 shown in fig. 2.

DISMANTLING

1. Unscrew the guide pin (fig. 40, Item 'B') from the rear cover. This pin is assembled with sealing compound and its removal requires an adequate and well-fitting screwdriver.

Remove the six retaining setscrews and carefully tap the rear cover with a soft mallet to break the joint. Position the control arm vertically and withdraw the cover after raising it to disengage the sliding block (arrowed, fig. 41) from the floating lever (fig. 42, Item 'B').

2. Again referring to fig. 42, remove link pin 'A' and tie the link fork out of the way. Pull back the slider 'E' with the floating lever 'B', turn lever 'B' clear of the rack extension, swing it back 90 degrees and lift it away, together with the slider. Unlock and unscrew the nuts 'C' from the coupling bolt and remove the bolt. The adjusting pin 'F' can then be withdrawn from the governor hub. Unscrew the two bolts 'D' and remove the guide bush.

3. Clamp the camshaft at its drive end and, using spanner 1 687 950 064, remove the flyweight assembly retaining nut and, if applicable, end float adjusting washer.

Use extractor 1 680 363 001 (fig. 43) to withdraw the flyweight assembly from the taper on the pump camshaft.

INSPECTION AND REPAIR

Wash all parts in paraffin and dry off with a compressed air jet. Discard used joints, splitpins and tabwashers.

Inspect each component for wear and damage,

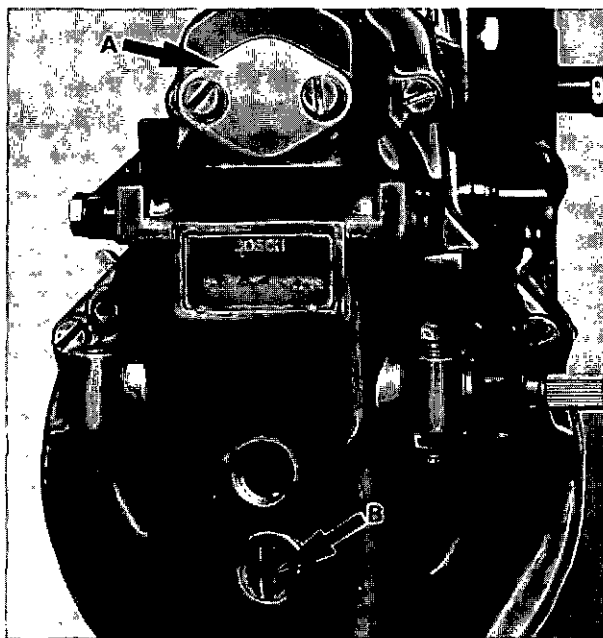

Fig. 40 Rear cover showing rack access 'A'; guide pin 'B'.

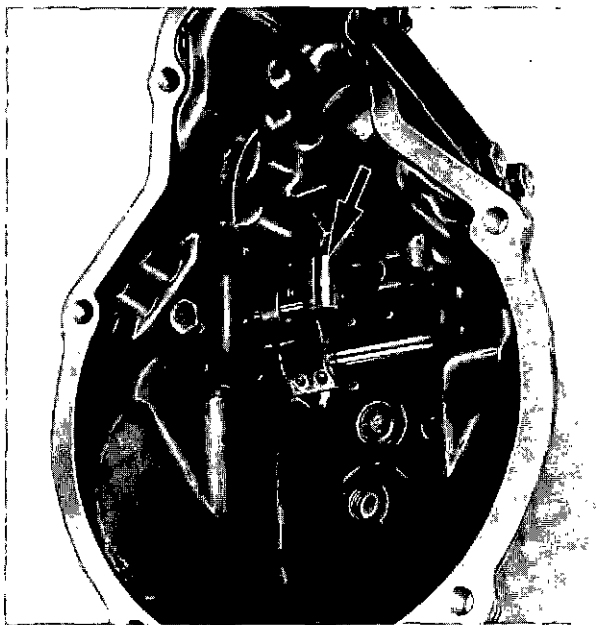

Fig. 41 Rear cover interior; sliding block arrowed.

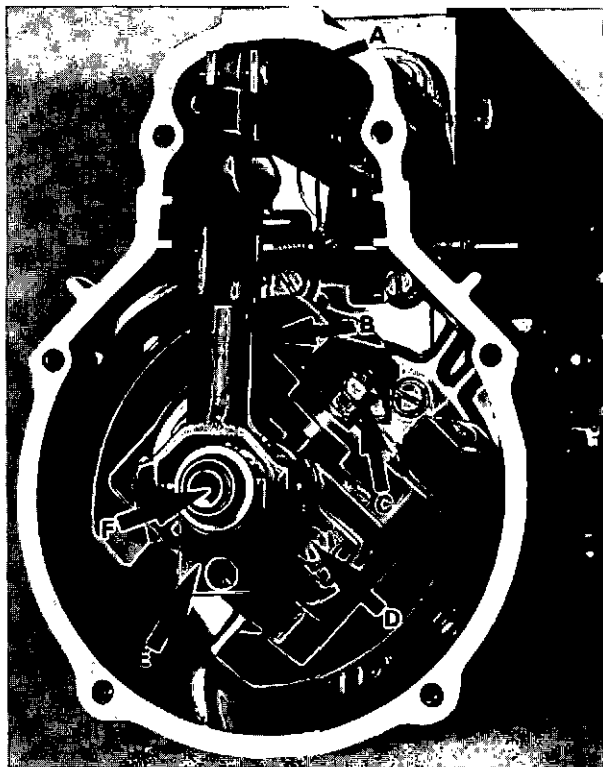

Fig. 42 Governor with rear cover removed.

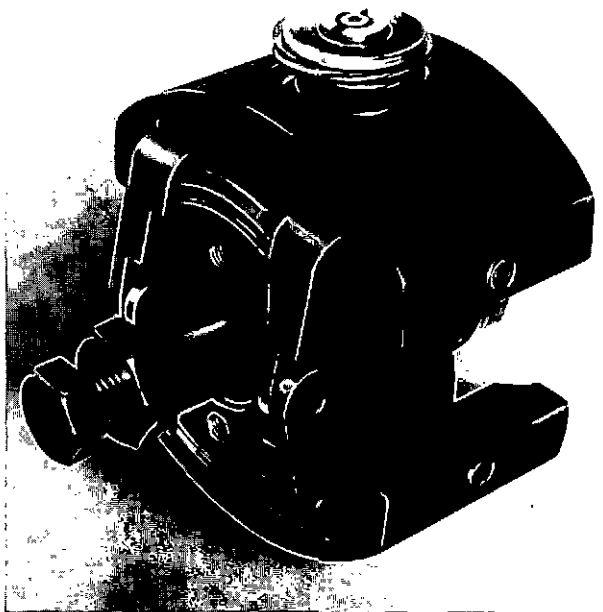

Fig. 43 Flyweight unit and extractor.

renewing where necessary. If required, instructions for reclaiming certain parts (e.g. flyweights) may be obtained from the Manufacturer, but in general it is recommended that if examination reveals excessive damage or accumulative wear the complete flyweight assembly be renewed. In addition to the rotating parts, closely inspect the linkwork, pins and guide slots for excessive clearances or damage, renewing components if defects are other than superficial (e.g. small burrs which can be stoned off) since these will tend to cause erratic governing.

Renewing flyweight assembly

If a new flyweight assembly is to be fitted its end float when mounted on the camshaft must first be checked and adjusted if necessary. For this purpose there must be no rubber blocks in the hub coupling.

Clamp the camshaft drive end, assemble the flyweight to its taper, fit the adjusting nut and tighten the nut to 49 Nm (36 lbf. ft.). Check that, with the camshaft held stationary, the flyweight assembly can be rotated between the rubber block stops and has an end float of between 0.05 and 0.1 mm (0.002 and 0.004 inch). Adjust if necessary, by varying the thickness of the washer beneath the retaining nut. On completion of this check, remove the flyweight assembly and fit the rubber blocks to the hub as described below.

Renewing rubber blocks in hub

The four rubber blocks of the cushion drive in the flyweight hub may be renewed by levering the coupling out of the articulation piece (fig. 44).

Lightly lubricate the new blocks, and enter them whilst refitting the coupling (fig. 45). Take great care to avoid cutting or otherwise damaging the rubber. Finally, tap or press the coupling fully home in the articulation piece.

Renewing flyweight springs

Remove both sets of springs by unscrewing their retaining nuts with spanner 1 687 950 000. Note any shims beneath them. If replacement springs are to be fitted, refer to the Parts Book to ensure that they are of the correct type for the governor specification. When replacing springs, screw their retaining nut to the basic setting shown in fig. 46, ensuring that this is identical on both spring assemblies.

NOTE: Springs may be changed on an installed governor via the oil filler orifice, as shown in fig. 47. A special tool 1 683 455 000, which engages with the filler cap thread, is available for this purpose.

Adjusting pin

This pin (fig. 48) connects the flyweight coupling bolt to the slider in the governor hub. Check that its spring and bearing surfaces are serviceable. The setting of the pin should not be disturbed unnecessarily but if adjustment is unavoidable it should be carried out as described later, under 'ASSEMBLING' and also in Part 4, Stage 'B'.

ASSEMBLING

1. Ensure that the tapers of the camshaft and governor hub are clean and undamaged. Although a keyway may be machined in the camshaft taper, no key is used. Assemble the flyweight unit to the camshaft and fit the adjusting washer and retaining nut. Clamp the drive end of the camshaft and tighten the retaining nut to 40 Nm (36 lbf. ft.), using spanner 1 687 950 064. After tightening, check that the cushion drive is free to operate by moving the flyweight assembly about the camshaft.
2. Fit the guide bush, tighten its securing bolts (fig. 42, Item 'D') and bend up their locking tabs. A sectioned view of the governor assembled to this stage is shown in fig. 49.
3. Check that the internal spring of the adjusting pin (fig. 48) has no end play and yet is not compressed. Adjust, if necessary, by turning the castellated carrier bolt relative to the eyed bearing bolt at the opposite end. Finally, set the bearing bolt 2 mm. below the end face of the adjusting bush, as shown, and assemble the adjusting pin to the guide bush bore, securing it by temporarily fitting the coupling bolt (fig. 50), which passes through the eye of the bearing bolt.
4. Pull the adjusting pin rearwards sufficiently to draw the flyweights inwards, but without exerting excessive load on the internal spring of the pin. In this position the measuring gauge 1 682 329 038 should fit snugly into the slider recess of the adjusting pin (figs. 48 and 51). Adjust, if necessary, by means of the bearing bolt in the adjusting pin, as shown in fig. 50.

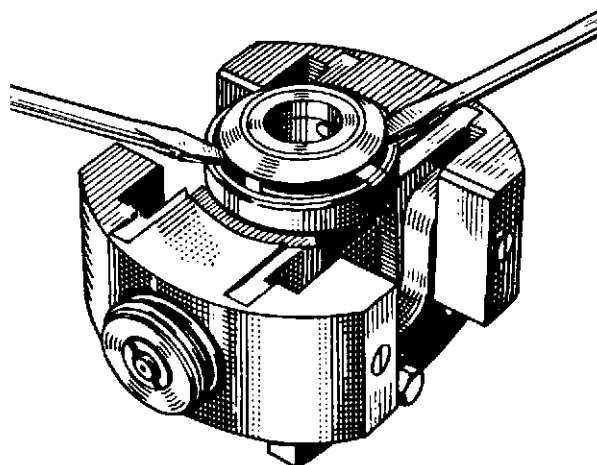

Fig. 44 Removing coupling and rubber blocks.

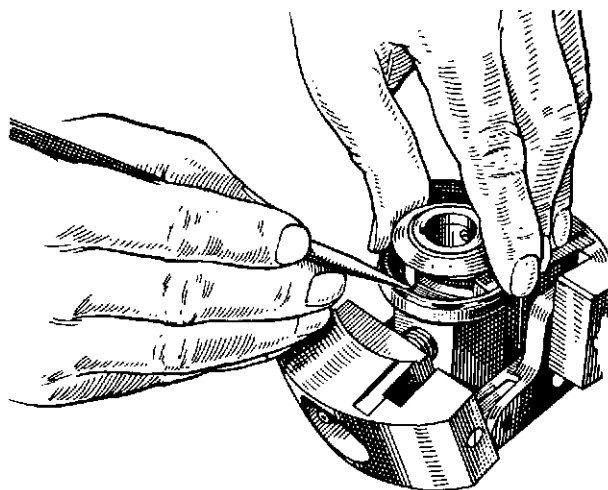

Fig. 45 Fitting coupling and rubber blocks.

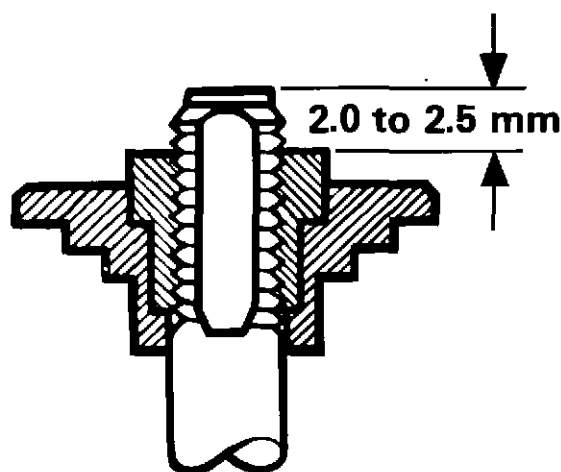

Fig. 46 Flyweight spring basic setting.

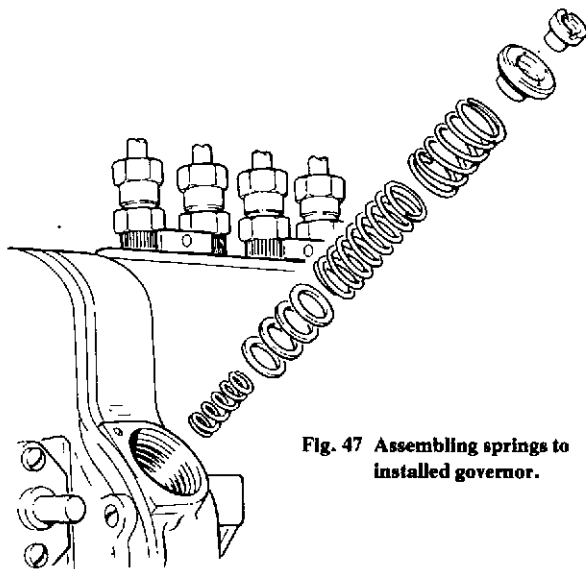

Fig. 47 Assembling springs to installed governor.

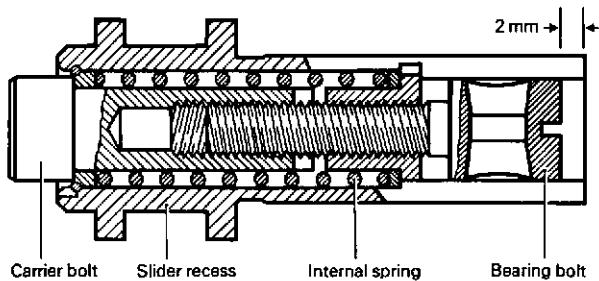

Fig. 48 Adjusting pin - sectioned.

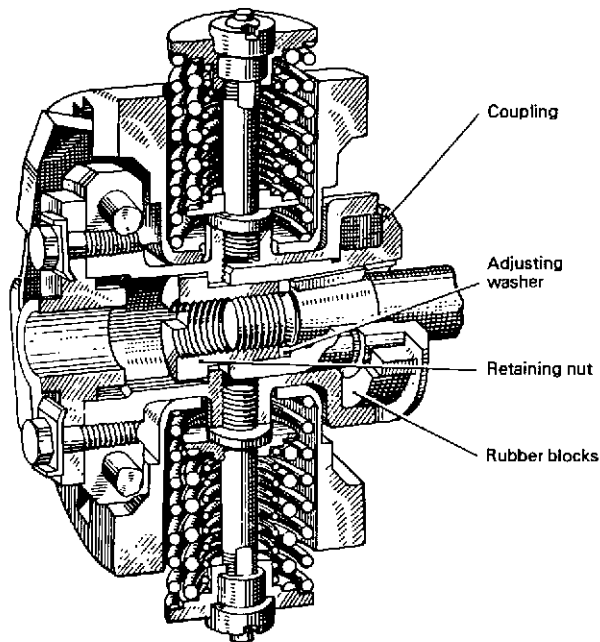

Fig. 49 Flyweight assembly - sectioned.

5. Assemble the coupling bolt so that it has an end float of 1 to 2 mm (0.040 to 0.080 inch), tighten its two nuts together and bend their lockwasher over one flat of each. Mount the slider and floating lever and fit the link pin, together with its splitpin (fig. 52).
6. Invert the governor rear cover and set the control lever to MAX. FUEL so that the pilot pin is at the bottom of the 'S' curve. Place a new gasket on the joint face and measure the distance between the gasket and the pilot pin, as in fig. 53. This should be 24.5 mm (0.965 inch). Using the depth gauge as illustrated, deduct from its reading the thickness of the measuring bar and add 3 mm (0.118 inch), which is half the diameter of the pilot pin. Adjust, if necessary, by means of shims beneath the 'S' curve plate.
7. Fit the feed pump and prime the injection pump with adequate engine lubricating oil for test running.
8. Final fitting of the governor rear cover is carried out during Stage 'B' of the Test Procedure (see Part 4). Concerning this, the following instructions are particularly important:
 - (a) Apply a non-setting compound to both sides of the joint gasket.
 - (b) Ensure that the sliding block is positioned with its long section uppermost (fig. 41) when it enters the slotted recess in the floating lever (fig. 42, Item 'B').
 - (c) Seal the guide pin thread with Loctite 241.

SPECIAL TOOLS — BOSCH RQV GOVERNOR

Bosch Part No.	Description
1 687 950 064	*Spanner, governor nut
1 680 363 001	*Extractor, governor flyweights
1 682 329 038	Measuring device, sliding sleeve position
1 683 455 000	Compressing tool, governor springs
1 687 950 000	Spanner, adjusting governor springs

*Also listed in 'SPECIAL TOOLS, 'PE' PUMP', Part 1 of this Section.

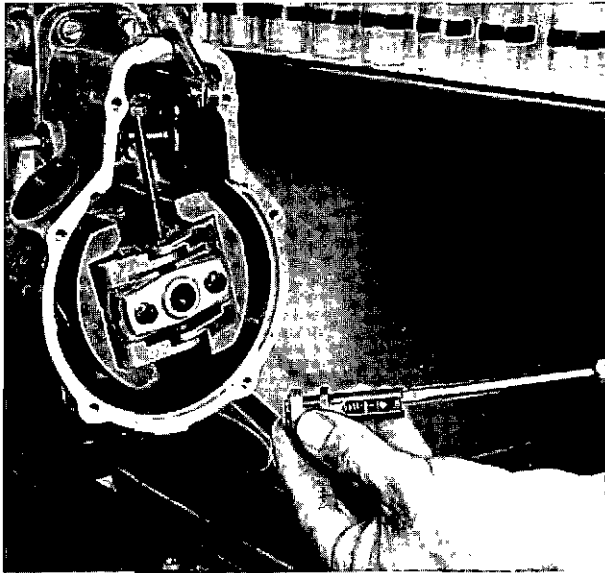

Fig. 50 Adjusting pin and coupling bolt.

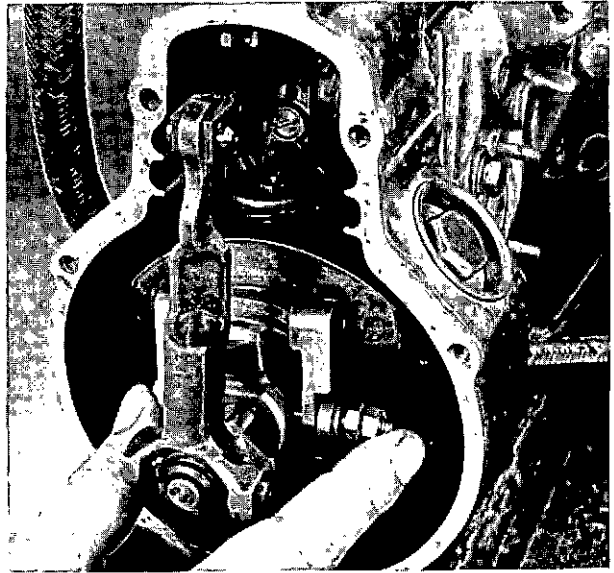

Fig. 52 Coupling bolt, floating lever and slider.

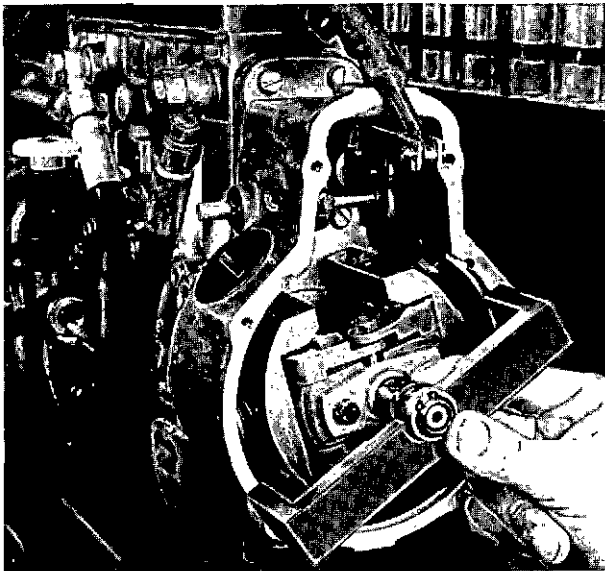

Fig. 51 Gauge for checking sliding sleeve position.

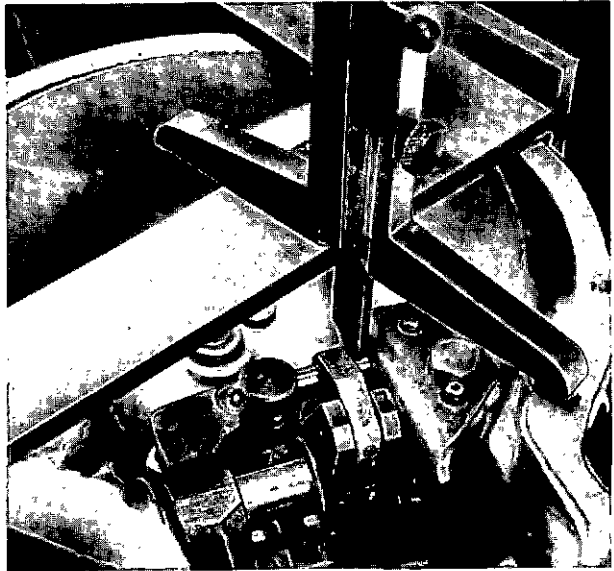

Fig. 53 Checking position of 'S' plate.

PART 3**FEED PUMP—TYPE FP/KD****Description**

The feed pump is the spring-loaded plunger type and is mounted in the crankcase 'V' alongside the fuel injection pump. Two inlet and two delivery spring loaded nylon valves are carried in the pump body, the pump being operated by a cam on the engine 'A' bank camshaft.

A hand operated priming pump is an integral part of the fuel pump and it is essential that the plunger is screwed down against the sealing ring to prevent fuel leakage when the pump is not being used.

Dismantling and inspection

Prior to removing the feed pump from the engine, slacken the priming pump casing, the blanking plugs above the remaining three valves and the plug retaining the plunger spring. Remove the priming pump, dismantle the valve assemblies, unscrew the plunger capnut and remove the spring, plunger and spindle. Remove the circlip retaining the tappet assembly and withdraw the unit. Check that the valves are seating correctly and that the springs are in good condition.

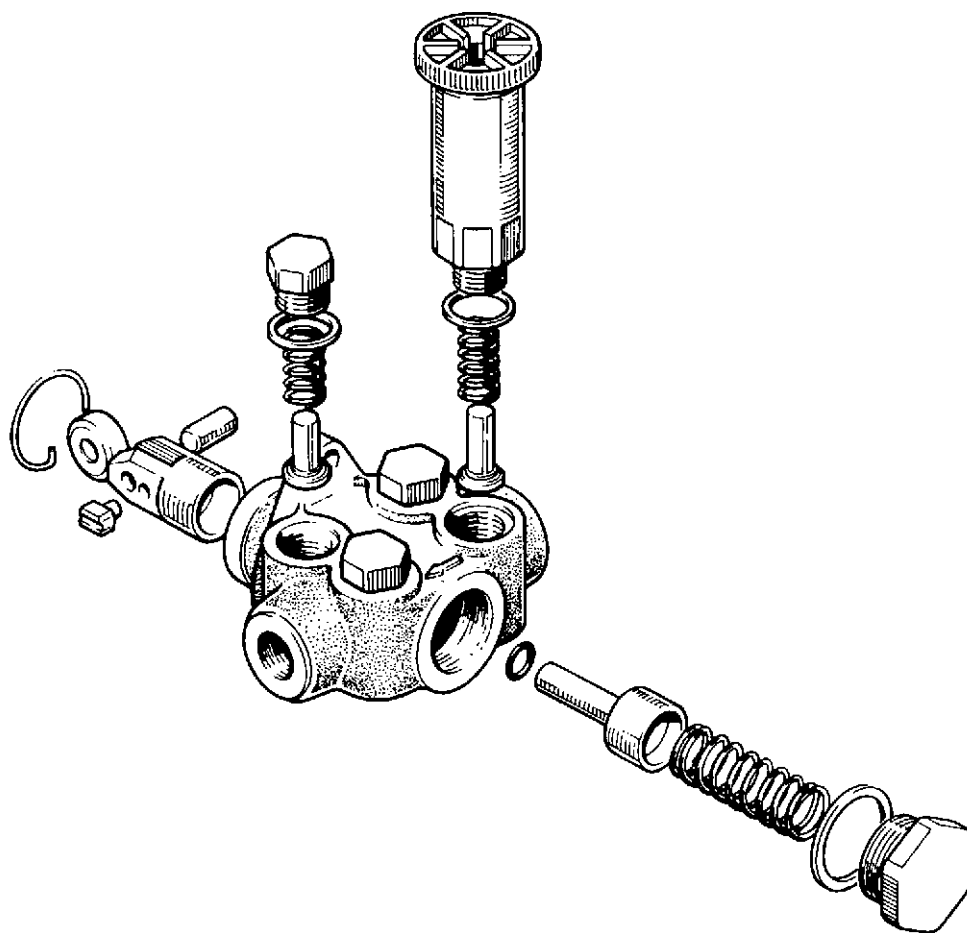

Fig. 54 Feed pump-exploded.

Inspect the plunger and spindle for wear or damage.

Note: The plunger and spring are supplied as a matched pair identified by a colour code, and if necessary must be replaced as such.

Examine the tappet and plunger bores in the housing for scores and wear. Dismantle the tappet assembly and inspect the components for wear and damage. Renew any items in doubtful condition. Permissible wear on the tappet face is 0.076 mm (0.003 inch).

Check the action of the hand priming pump and replace as a unit if found to be unserviceable.

Assembling

Thoroughly clean all parts and smear with a light

coating of oil. Assemble the pump in the reverse sequence of dismantling, using new joint washers.

If possible, carry out a leakage test by blanking off the outlet connection and applying air pressure at 193 kN/sq. m (28 lbf/sq. inch) to the inlet connection with the pump immersed in fuel oil. Check for air bubbles, and at the same time operate the plunger to ensure that there is no leakage from the tappet bore.

Check the feed pump output during the testing of the injection pump. The low-pressure relief valve is carried in the bolt securing the spill pipe banjo to the injection pump gallery and opens at 140 to 210 kN/sq. m (20 to 30 lbf/sq. inch); feed pump output pressure should easily exceed this. Particulars of further tests involving special apparatus are available from the pump Manufacturer, if required.

PART 4—TEST PROCEDURE

EQUIPMENT SPECIFICATION

Bosch Part No.	Description
—	Test Bench, Bosch 385
1681 443 022	*Test injector, 175 ats., 12 mm and 13 mm bore pumps (1 per element).
1680 750 060	*HP pipe, 12 mm and 13 mm bore pumps (1 per element).
1680 430 007	*Drive coupling.
1417 413 025	*Overflow valve.
1688 130 085	Measuring rig, plunger lift, less dial gauge.
1687 233 011	†Dial gauge for 1688 130 085.
1688 130 030	Measuring rig, rack travel, less dial gauge.
1687 233 015	Dial gauge for 1688 130 030.
1687 950 525	†Spanner, open ring, delivery valve.
0681 440 006	Setting rig, control lever position.
1688 130 095	Measuring rig, sliding sleeve travel.

*If a Hartridge 1100 Test Bench is used these items are replaced by the following, and the Bosch FP/KD feed pump, together with its pressure relief valve on the injection pump, are included in the circuit.

Rolls-Royce Part No.	CAV/Hartridge Part No.	Qty.	Description
—	7244-108	8	Test injectors, 175 ats., 12 and 13 mm, bore pumps.
OD 18514	—	8	HP pipe, 8 x 3 x 760 mm., 12 and 13 mm, bore pumps.
OD 18526	AFB 27	4	Holding-down bolt.
OD 18527	FP 164	4	Banjo union.
OD 18528	AT 16/24/8	3	Banjo bolt, 14 x 1.5 mm.
OD 18529	ALP 104	4	Pipe, flexible.
OD 18530	FP 383	1	Drive coupling, 25 mm. taper.
OD 17531	—	8	Washer, copper, 14 mm.

† Also listed in 'SPECIAL TOOLS, BOSCHE PE PUMP' (see Part 1)

Test Oils

Bosch: 01 61 v 11
Esso: Calibration Fluid iL 1838

Shell (Overseas): Calibration Fluid B
Shell (UK): Calibration Fluid C

TEST SEQUENCE

Testing is done with the pump mounted on the test bench, using the equipment specified. The Test Schedule appropriate to the engine application, as listed at the end of this Part, is then carried out in the following three-stage sequence:

- A Pump pre-stroke setting, phasing and calibrating
- B Governor setting
- C Final setting of pump/governor assembly

**STAGE 'A'—PRE-STROKE SETTING
PHASING AND CALIBRATING**

Note: The operations in this Stage are carried out with the governor rear cover removed.

1. Pre-stroke setting

This involves setting the plunger lift to port closure on No. 1 element, as follows:

- (i) Remove the LP relief valve assembly and fit a blanking plug similar to that at the other end of the inlet gallery.

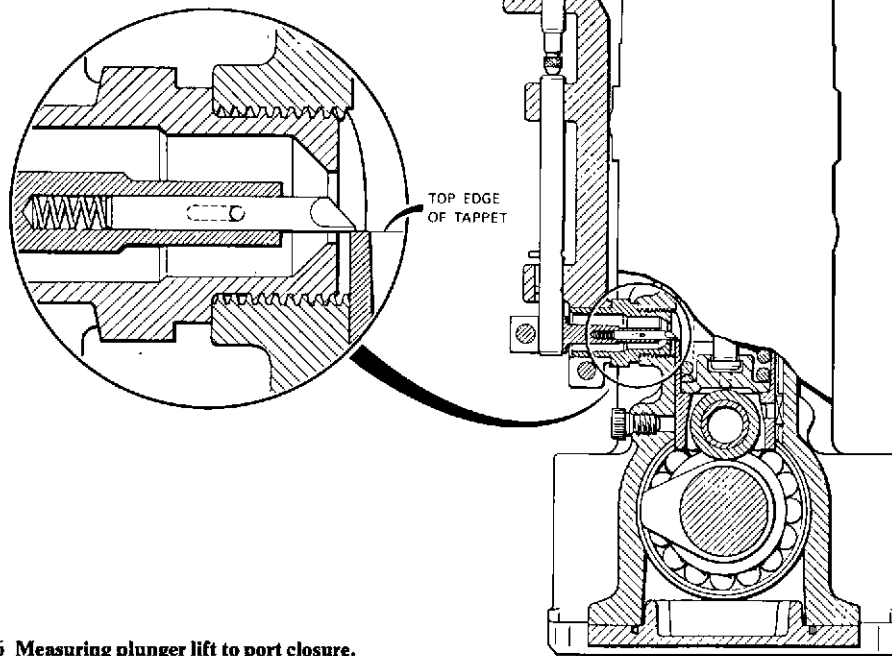

Fig. 56 Measuring plunger lift to port closure.

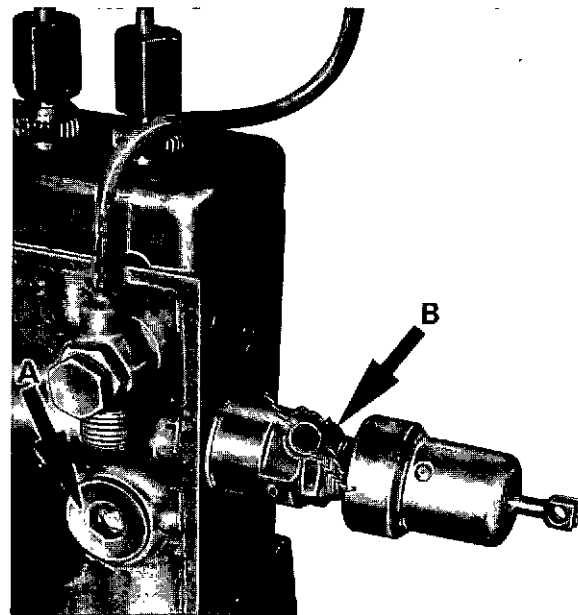

Fig. 55 Tappet access plug 'A'. Rack stop locknut 'B'.

- (ii) Unscrew the access plug to No. 1 tappet (see fig. 55, Item 'A') and turn the camshaft until No. 1 tappet is approximately at BDC.
- (iii) Referring to fig. 56, fit measuring rig 1 688 130 085 to the access plug tapping, ensuring that the probe rests on the upper edge of No. 1 tappet, as in the inset. Assemble dial gauge 1 687 233 011 to the rig and set it to zero.
- (iv) Switch on the feed pump of the test bench. Open the leak-off screw on No. 1 test injector and increase feed pressure until oil emerges from it.
- (v) Turn the pump camshaft manually in direction of rotation (clockwise, viewed from drive end) until oil just ceases to flow from the leak-off. The dial gauge reading at this point should be within the limits specified against 'Plunger lift to port closure' in Stage 'A' of the Test Schedule. Adjust, if necessary, by means of the phasing shims beneath the barrel/delivery valve assembly (fig. 57), reducing shim thickness to rectify late closure, and vice versa. Pumps with serial numbers prefixed '626' and later have two-piece shims which can be changed without removing the barrel/delivery valve assembly. Variation of shim thickness affects the dial reading by a corresponding amount. When correct, leave camshaft at No. 1 port closure and set the pointer of the graduated disc on the pump drive to a convenient figure, noting this for reference during phasing.
- (vi) Remove measuring rig 1 688 130 085, together with its gauge, and refit the blanking plug (fig. 55, Item 'A').

2. Phasing

Turning the camshaft in direction of rotation, check the port closures of the remaining elements in sequence order, as applicable, in multiples of 45 degrees, using No. 1 as a datum in each case. Correct any element found beyond limits (± 0.5 deg.) by means of its phasing shims as described earlier. Note that if barrel/delivery valve assemblies are disturbed they should be reset at mid-slot position when

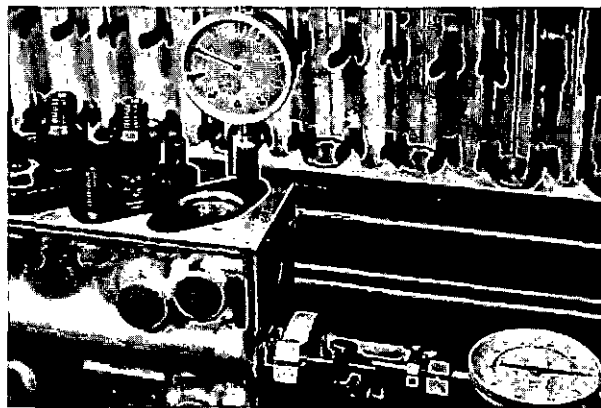

Fig. 57 Adjusting thickness of phasing shims.

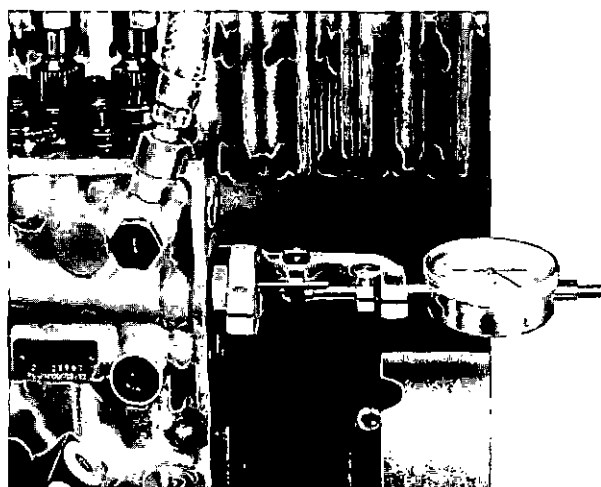

Fig. 58 Measuring rack travel.

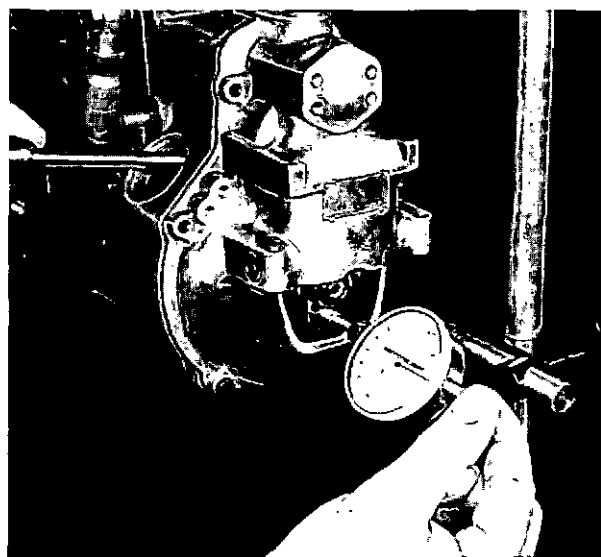

Fig. 59 Measuring sliding sleeve travel.

their securing nuts are tightened after phasing, thus providing calibration adjustment in either direction.

3. Calibrating

- (i) Remove the blanking plug fitted to the LP relief valve tapping for pre-stroke setting and substitute overflow valve 1 417 413 025, connecting its outlet pipe to the test bench oil return system. Set test oil supply pressure to 152 kN/sq. inch).
- (ii) Remove the excess fuel device (or smoke stop, as applicable) and fit the rack travel measuring rig 1 688 130 030, together with its dial gauge 1 687 233 015, as shown in fig. 58. With the control rack in the STOP position, zero the dial gauge and tighten the clamping screws. Ensure that the rack can travel its full range of approximately 21 mm.
- (iii) Referring to Stage 'A' of the appropriate Test Schedule, run the pump at 700 r.p.m. and measure the rack travel and the delivery from each element. These should conform to the figures in heavy type at the head of Columns 2 and 3 of the Table under 'Calibrating'. The spread should not exceed the figure quoted in Column 4. Correct errors on individual elements as necessary by rotating their flange bushings within the limits of the adjusting slots, using open ring spanner 1 687 950 525. On completion, tighten the flange bushing nuts to between 39 to 43 Nm (29 to 32 lbf. ft). Carry out the remaining tests in the Table in Stage 'A'. In each case the delivery from every element should conform to the limits quoted, and failure to do so indicates a faulty element which should be renewed.

STAGE 'B'—GOVERNOR SETTING

1. Setting sliding sleeve travel

Note: The sliding sleeve consists of the slider and the adjusting pin, as an assembly (Items 'E' and 'F' respectively in fig. 42).

- (i) For protection, a cutaway rear cover should be fitted whilst this operation is carried out. Referring to fig. 59, mount the measuring rig 1 688 130 095 attaching

the magnetic base of the dial gauge to the slider. With the pump stationary, pre-load the gauge approximately 20 mm; at the same time take up any play in the governor mechanism by lightly pulling on the gauge spindle as shown.

- (ii) Referring to Stage 'B' of the appropriate Test Schedule, carry out test running working to the upper limit where possible. Make corrections by equal adjustment of the flyweight spring retaining nuts; a difference of one notch between them is permissible. Turning the nuts clockwise reduces sleeve travel, and vice versa.
- (iii) Fit the permanent rear cover. Refer to Part 2 'GOVERNOR', under 'Assembling', Item 8, for details of this operation.

2. Checking run-out characteristics

- (i) Remove the speed control lever, reverse it and refit it in the same relative position.
- (ii) Attach the setting rig 0 681 440 006 as shown in fig. 60. Note that the rack travel measuring rig used in Stage 'A' is still fitted.
- (iii) Referring to Stage 'B' of the appropriate Test Schedule, run the pump at the speed specified at the top of Col. 1, measure the rack travel and compare it with the limits at the top of Col. 2. If correction is necessary, use the following three methods in sequence order until successful:
 - (a) Vary the basic settings of the control lever within the limits of ± 3 degrees.
 - (b) Alter the setting of the adjusting pin (figs. 48 and 50). Turning the bearing bolt one half-turn clockwise reduces rack travel approximately 2.25 mm., and vice versa.
 - (c) Vary the thickness of the shims beneath the 'S' plate (fig. 53). Reducing shim thickness by 0.15 mm. reduces rack travel approximately 1 mm., and vice versa.
- (iv) Leave the control lever set as the completion of (iii) above and carry out the subsequent tests in Cols. 1 and 2.

STAGE 'C'—FINAL SETTING

1. Setting MAX. FUEL stop

- (i) Remove the rack travel measuring rig 1 688 130 095, together with its dial gauge, and fit the excess fuel device or smoke stop, as applicable.
- (ii) Referring to Stage 'C' of the appropriate Test Schedule, run the pump at the speed quoted in the first column of the Table and measure the fuel delivery from each element. Compare the results with the fuelling figure shown on the Rolls-Royce data plate affixed to the side of the governor.
Adjust, if necessary, by altering the setting of the rack stop. Referring to fig. 55, slacken locknut 'B' and screw the stop clockwise to reduce fuelling, or vice versa as required.
- (iii) On completion, tighten the locknut.

2. Governor break-away

- (i) Remove the speed control lever (reversed during Stage 'B') and refit it in its normal position.
- (ii) Remove the rack access plate on the governor rear face (fig. 40, Item 'A') and mount a dial gauge with its button resting on the rack extension. If necessary a bolt may be fitted to the tapping in the extension to facilitate this. Pre-load and zero the gauge.
- (iii) Set the control lever on the MAX. FUEL stop (fig. 61, Item 'B'). Referring to the Table in Stage 'C' of the appropriate Test Schedule, run the pump and note the speed at which the rack commences to move, as indicated by the dial gauge. This speed should be between the two quoted in Col. 3. If the speed recorded is incorrect, extract the lead seal, (fig. 61, Item 'A'), remove the cover screw beneath it and adjust the MAX. SPEED stop 'B' as necessary. Screw the stop clockwise to increase speed, and vice versa. On completion, tighten the stop locknut, refit its cover, and replace the rack access plate.

3. Excess fuel

Referring to Stage 'C' of the appropriate Test Schedule, depress the EXCESS FUEL lever, run the pump at the speed specified in the Table and check that fuel delivery is within the limits quoted.

4. Idling

Adjust the stop (fig. 61, Item 'C') to give fuelling of 2 ccs. per 100 strokes at 325 r.p.m. Final adjustment is made on the engine at installation.

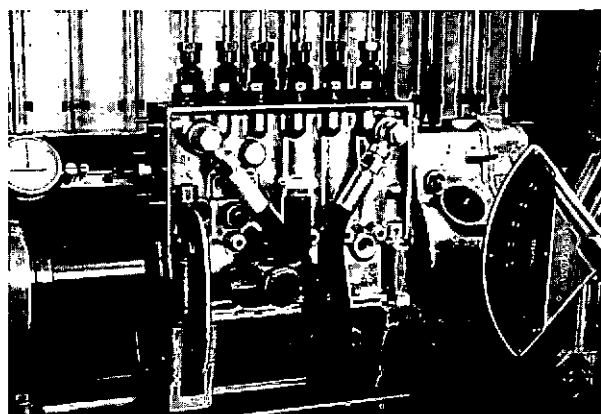

Fig. 60 Checking governor run-out

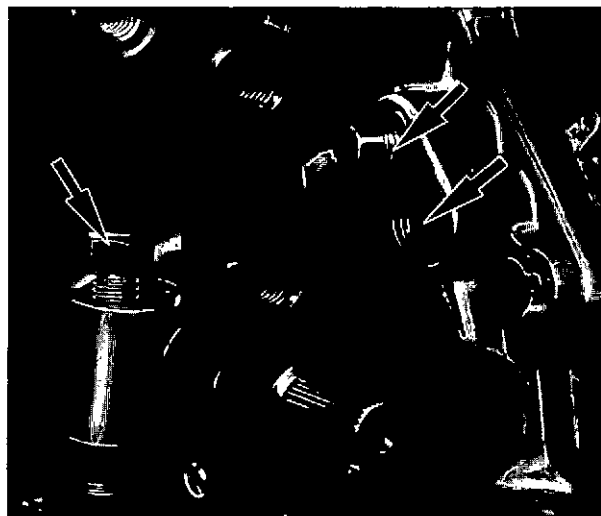

Fig. 61 Control lever stops and seal

PART 5—AMBAC GOVERNING

Description

The modular designed Ambac governor is offered as an alternative on all CV8 engines.

The system consists of a magnetic pick-up, electronic control unit, a frequency trim potentiometer, and an electromagnetic actuator. The actuator and pick-up are engine mounted with the other accessories located in a suitable position. A fast system response is obtainable over a broad range and the various elements of the system are easily replaced if necessary.

Assembling (fig. 62 and fig. 63)

The following sequence must be strictly adhered to when the unit is being assembled to the fuel pump.

1. Secure the bellows (3) to the outside ring at the pump rack using the clamp (4).
2. With holding screws (5) and lock washers secure the rack connector link (14) in position.
3. Fit the other side of bellows (3) to the rack connecting link (14) and secure with clamp (4).
4. Remove loose cover (11) and gasket (10).
5. Fit 'O' ring (6) to the housing.

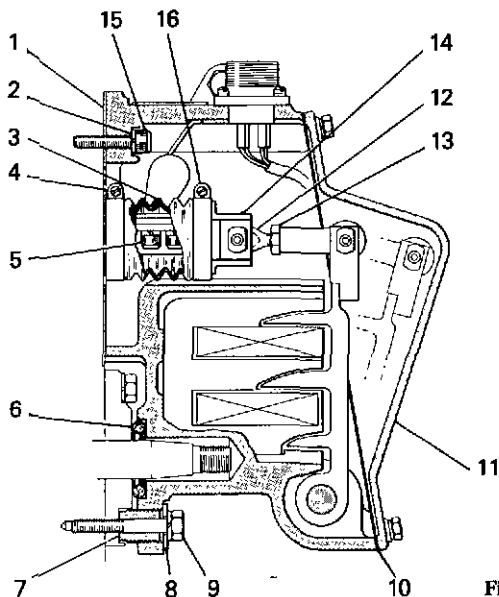

Fig. 62

6. Back off the spacer adjusting screws (7).
7. Place the gasket (1) in position and secure the governor unit to the pump using mounting screws (9 and 15) together with lock-washers (8 and 2). Hexagon headed screws to be finger tight only at this stage.
8. Remove one hexagon screw (9) and bring adjusting spacer (7) against the surface in pump cover. Refit hexagon screw and torque to 9 to 11 Nm (80 to 90 lbf. in). Repeat this operation with the remaining hexagon screw.
9. Check the tightness of all four mounting screws to a torque loading of 9 to 11 Nm (80 to 90 lbf. in).
10. Position the rod and bearing (12) to allow armature travel of 1 to 4 mm when the rack is fully in towards pump.
11. Assemble spring (20) and bracket in position and secure with screw (17) and locknut (18) to the rack connecting link (14) and rod end bearing (12). Bracket must be free on spring retaining pin.
12. Hold the stop lever (16) against stop in housing with the rack in the extreme position towards pump. Turn the adjusting screw until it makes contact with the lever (16) and then back off screw approximately one full turn.
13. Fit cover (11) and gasket (10) to the housing.
14. The top two cover securing screws have provision for a lock-wiring seal.

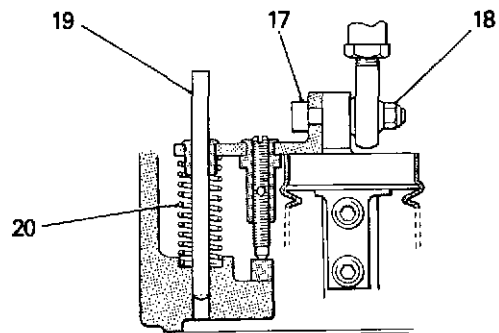

Fig. 63

ELECTRIC FAULT DIAGNOSIS

If the governor does not operate, measuring in sequence, voltage between the various control unit terminals and ground (Terminals F, G, H and T are ground) will indicate the possible fault. Should all 5 Voltage tests indicate normal valves, the defect must be in the actuator or in the wiring to the actuator.

TERMINALS	NORMAL VALUE	PROBABLE CAUSE OF NON-NORMAL READING
S	1.0 volt AC-RMS minimum while cranking.	<ol style="list-style-type: none"> 1. Defective magnetic pick up. 2. Gap too large between pick up and gear teeth. 3. Improper or defective wiring to the pick up.
K	10.1 ± .20 volts DC while energized (Internal regulated D.C. D.C. supply).	<ol style="list-style-type: none"> 1. D.C. power not connected or low battery voltage. 2. Frequency trim potentiometer shorted, ground or mis-wired. 3. Wiring error. 4. Defective control unit.
L	<p>Above 5.1 volts D.C. while cranking. (Inverse speed error signal).</p> <p>Above 5.1 volts is under speed signal. Below 5.1 volts is over speed signal.</p> <p>On speed will indicate a steady 5.1 volts.</p>	<ol style="list-style-type: none"> 1. Frequency adjust set too low. Turn clockwise. 2. Defective control unit.
N	8.5 to 9.5 volts D.C. while cranking. (Proportional actuator voltage).	<ol style="list-style-type: none"> 1. Defective control unit. 2. Battery voltage may be too low while cranking.
B	2.5 volts D.C. maximum while cranking. (Transistor voltage).	<ol style="list-style-type: none"> 1. Output transistor open (defective control unit). 2. *Defective actuator. 3. Error in wiring to actuator.

Continued

FURTHER FAULT TESTS

SYMPTOM	TEST	PROBABLE TROUBLE
Engine overspeeds	Determine voltage on terminal "L". Should be less than 5.1 volts D.C.	<ol style="list-style-type: none"> 1. Frequency set too high. Turn frequency adjust counter-clockwise. 2. Defective control unit.
Engine overspeeds	Measure the voltage across the insulated nut located on the side of the control unit. Should be more than 2.5 volts D.C.	<ol style="list-style-type: none"> 1. Output transistor shorted (Defective control unit). 2. Wiring to actuator incorrect.
Rack does not move	Measure battery voltage at the battery while cranking. Must be 8.0 volts D.C. minimum.	<ol style="list-style-type: none"> 1. Insufficient battery voltage. Put a momentary connection from terminal "B" on the control unit to negative ground while cranking (Terminal "G" is ground). 2. Replace with battery of higher amp hour rating.
Rack does not move	Ground the insulated nut located on the side of the control unit. Rack should move to full open position.	<ol style="list-style-type: none"> 1. Wiring to actuator or battery incorrect. 2. Actuator or linkage bound. 3. *Defective actuator.

***DEFECTIVE ACTUATOR**

Should the coils of the actuator become open or shorted, replace the actuator. If the coils are not open or shorted, the wiring or connectors are defective.

**TEST PROCEDURE FOR ROBERT BOSCH FUEL PUMP FITTED
WITH AMBAC INTEGRAL ACTUATOR AGB 250 A1**

Fit fuel pump to test rig in normal manner, with cam box primed with oil and oil holes blanked off.

Connect a 12 or 24- D.C. power supply (as available) to the actuator, as shown on fig. 64 (a) or (b). With voltage supplied the pump should deliver full fuel when driven, and the standard pump calibration checks can be undertaken; refer to standard test procedure.

On completion of calibration tests, the power supply should be disconnected with the pump still being driven at rated speed. Fuel delivery should cease immediately the power is disconnected.

The pump should return to full delivery when voltage is re-applied to the actuator, and should cease immediately when the stop lever is moved by

hand to the stop position.

If any governor malfunctions are indicated by the above tests, they must be rectified before returning the pump to the engine.

If NO D.C. POWER SUPPLY IS AVAILABLE, the governor operation cannot be checked. The pump operation can be checked by the following procedure:

Remove actuator end cover. Push armature (and rack) fully over to the full fuel position, i.e. fully into the pump body. Hold firmly in this position with a strong spring or length of rubber.

With the rack held firmly in this position, the fuel pump rig checks can be performed, as laid down in the standard test procedure.

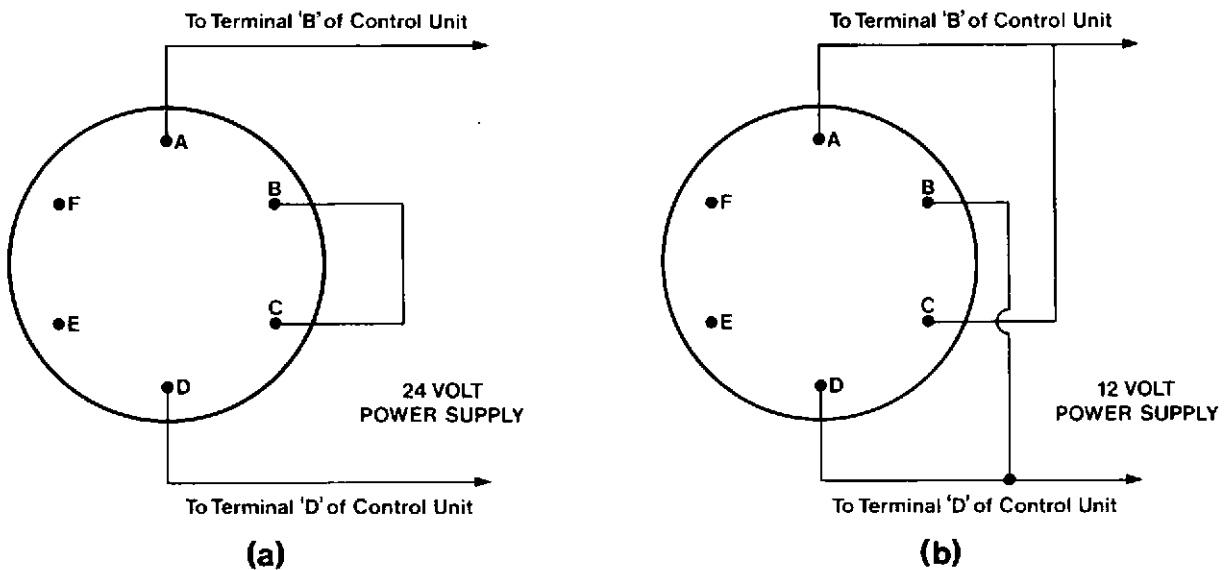

Fig. 64 Actuator connector wiring diagram.

PART 6—FUEL INJECTORS

Description

The Bosch type injector consists of a 'KBAL' type nozzle holder fitted with a 'DLL' type nozzle. The nozzle valve has six spray holes of 0.33 mm diameter x 0.7 mm long and is lapped into a mated body to form a nozzle assembly. It has an opening pressure of 240 bars (240 atmospheres) which may be adjusted by fitting shims of the required thickness under the spring. Shims are available in varying sizes. A spill connector is fitted in the side of the injector body.

Dismantling

Secure the injector in a suitable clamp and remove the nozzle capnut. Withdraw the nozzle assembly, transfer block, spring cap and spring together with the adjusting shim, and place them in a suitable tray.

Note: The needle valve and nozzle body are a matched pair and must be kept together.

Cleaning

Wash the components in paraffin and dry off with compressed air. Remove any carbon or dirt from the

nozzle assembly using the tools supplied in the Cleaning kits, CVK 508 or KRP 1089. Dip the needle valve in test oil and insert into the nozzle body. Nozzle spray holes have a diameter of 0.33 mm and it is important that they are free of all carbon. Use the correct cleaning wire supplied in the cleaning kit to remove any carbon from the holes and blow out with compressed air. When all the holes are clear, soak the nozzle in a carbon solvent such as 'Ardox' 690 or 1618 obtainable from Ardrex Limited, Commerce Road, Brentford, Middlesex.

Caution: Only tools supplied in either of the previously quoted cleaning kits should be used.

Inspection

After cleaning the nozzles carry out a visual examination using a magnifier, with particular attention to the following points:

1. Check the needle valves for pounded or rough valve seats and wear or damage.
2. Check the nozzle body for damage to the seat or worn injection holes.

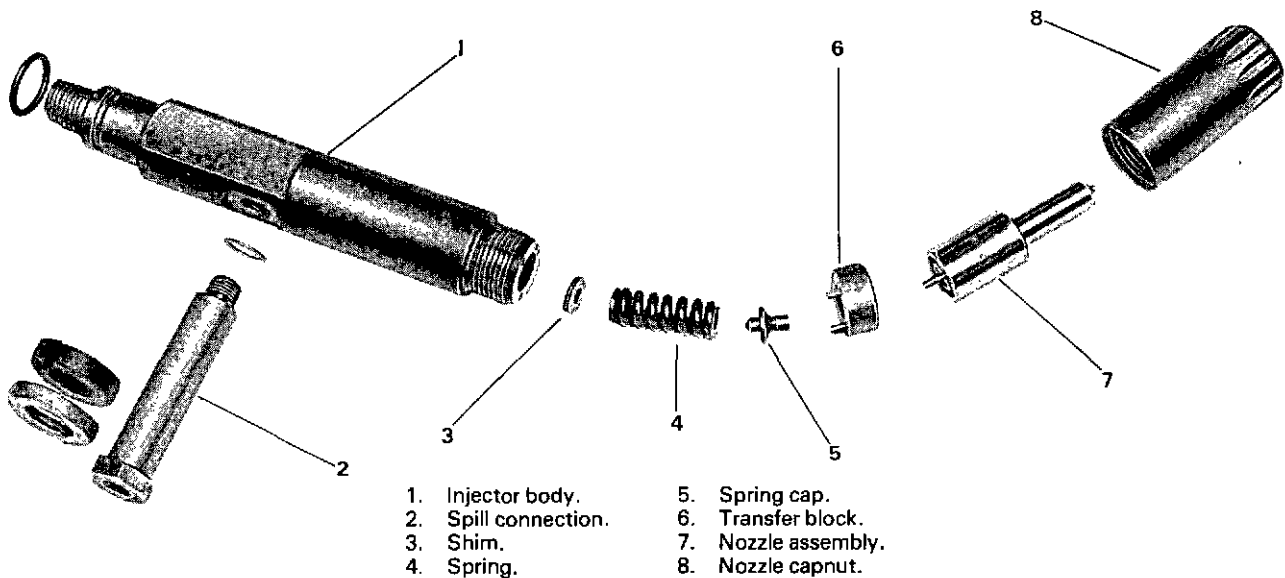

Fig. 65 Injector—Exploded view.

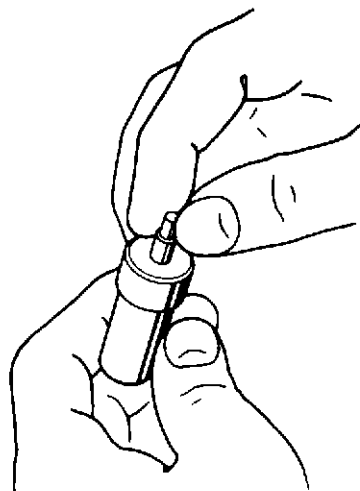

Fig. 66 Slide test.

Following the visual examination, a slide test as in fig. 66 should be conducted on all nozzles. Hold the nozzle body in a near vertical position and insert the needle valve, previously dipped in test oil. The needle valve when raised to approximately one third of its guide length and then released, should slide down on to its seating under its own weight.

Assembling

Assemble all the components to the injector body in the correct sequence. Use the shim as originally fitted and ensure that the transfer block is correctly located. Secure the injector in a suitable clamp and tighten the nozzle capnut to a torque load of 81 Nm (60 lbf. ft.).

Testing

Absolute cleanliness is essential during all tests. The testing should be carried out using a nozzle setting outfit filled with clean test oil. Open the air-vent screw and operate the hand lever until bubble-free oil flows from the vent screw bore. Tighten the air-vent screw and continue pumping until bubble-free oil emerges from the delivery line connection. The nozzle tester outfit is now ready for use.

Alternative recommended Test Oils

Bosch: 01 61 v 11. Shell (Overseas): Calibration Fluid B. Esso: Calibration Fluid 1L 1838. Shell (U.K.): Calibration Fluid C.

Warning: When testing an injector, the nozzle must be turned away from the operator, since the spray has sufficient force to penetrate the human skin.

Setting and Testing

The following tests must be carried out:

1. Opening pressure test.
2. Leakage test.
3. Spray pattern and chatter test.

Opening pressure test

The opening pressure of the injectors is specified under the Engine Data in this Manual and should be adjusted accordingly.

With the gauge open to pressure, slowly depress the hand lever until the nozzle ejects with a slight chattering and take note of opening pressure on gauge. If the reading differs from the specified opening pressure it must be adjusted by changing the total shim thickness; use only a single shim where possible. Increase shim thickness to obtain more pressure and lessen shim thickness to reduce pressure. When dismantling the injector to adjust shim thickness ensure that strict cleanliness is maintained. Continue with this process until the correct opening pressure is obtained.

Caution: When the pressure gauge is open to pressure, always increase or decrease pressure slowly to prevent any possible damage to the gauge.

Leakage test

Operate the hand lever of nozzle tester until a pressure of 20 bar (19.7 atmospheres) below the specified opening pressure is indicated. Under this pressure, the nozzle is considered leakproof if not one drop of oil emerges at the end of nozzle during a 10 second period.

Before rejecting a nozzle assembly ensure that leakage is not due to dirt on the seating faces.

Chatter test and spray pattern

Caution: For this test it is essential to by-pass the pressure gauge.

When the hand lever is operated at approximately two downward movements per second, it is normal to obtain nozzle chatter. During this test the spray need not be even and well atomised.

With increased movements of the hand lever the injector nozzle must chatter audibly and/or give a well atomised spray.

Nozzle tester maintenance

At regular intervals depending on use, the filter element must be renewed and, if necessary, the test oil changed. It is advisable that at regular intervals of not more than two years duration the equipment should be checked for accuracy at a service depot.

SECTION 12—LUBRICATION SYSTEM

Description

CV8 industrial engines use a wet-sump system and are fitted with a cast aluminium sump which is reversible to suit different engine applications. Lubricating oil is drawn through a suction strainer by a spur gear type oil pump slung beneath the front end of the engine, and driven from the main gear train. The oil is delivered under pressure to the two canister type filters and thence through the single tube pack type oil-to-coolant heat exchanger, the base of which forms the oil filter header bracket.

By way of a passageway near the front of the 'A' bank side of the crankcase the oil then enters a gallery running through the engine 'V'. A transfer housing, bolted to the rear face of the crankcase, directs the flow of oil into the main gallery running parallel to the previous gallery. Drillings from the front end of the

main gallery direct the oil into two auxiliary galleries running the length of the crankcase above the camshafts, whilst smaller drillings direct an oil supply to each main bearing housing. Oil is directed from the auxiliary galleries through drillings to the camshafts, valve gear and cylinder liner outer walls.

Pipework, from a fitting at the rear end of the main oil gallery, delivers oil to the turbocharger bearings. Another pipe, adjacent to the oil feed connection, returns oil from the fuel injection pump assembly and turbocharger to the crankcase. Drillings from the periphery of the front main bearing housing carry a supply of oil to the idler gear axles in the main gear train.

A hole drilled through the top of each cylinder block into the relevant auxiliary gallery, allows oil to be delivered through passageways in the cylinder

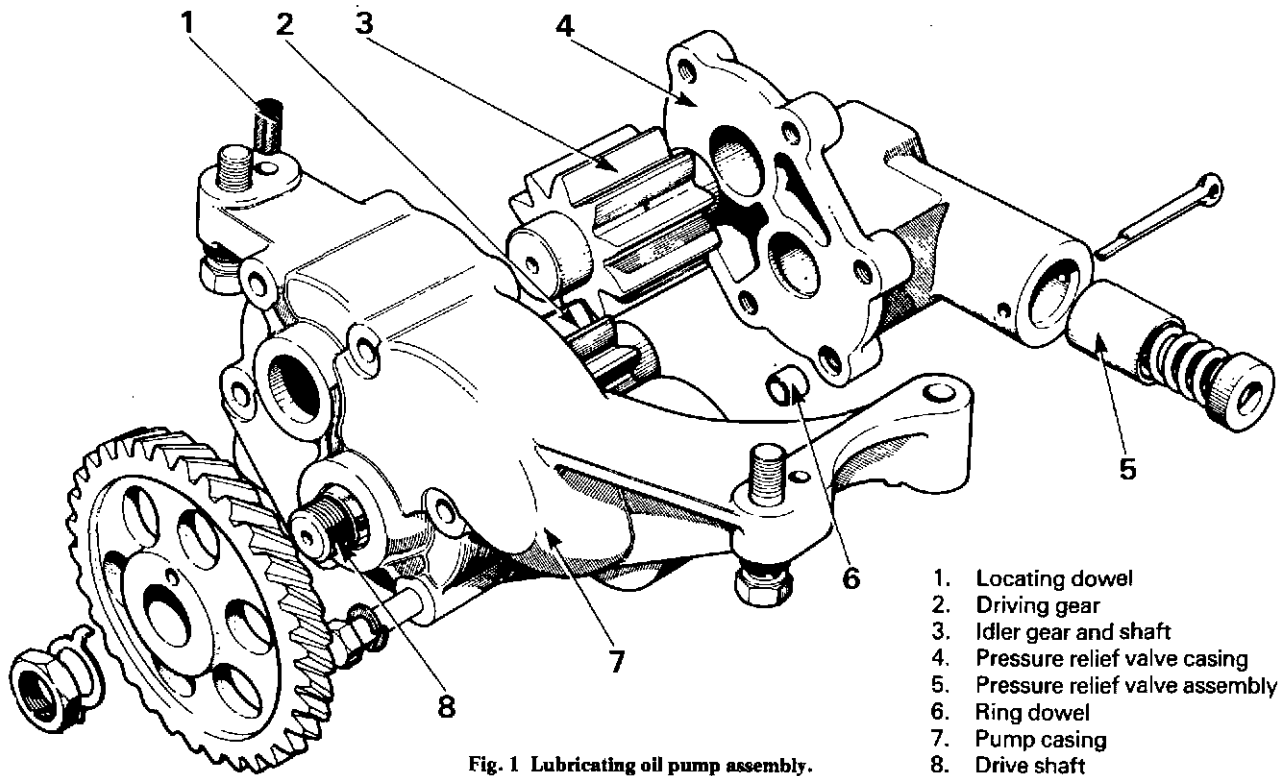

Fig. 1 Lubricating oil pump assembly.

TYPICAL LUBRICATION SYSTEM — SCHEMATIC

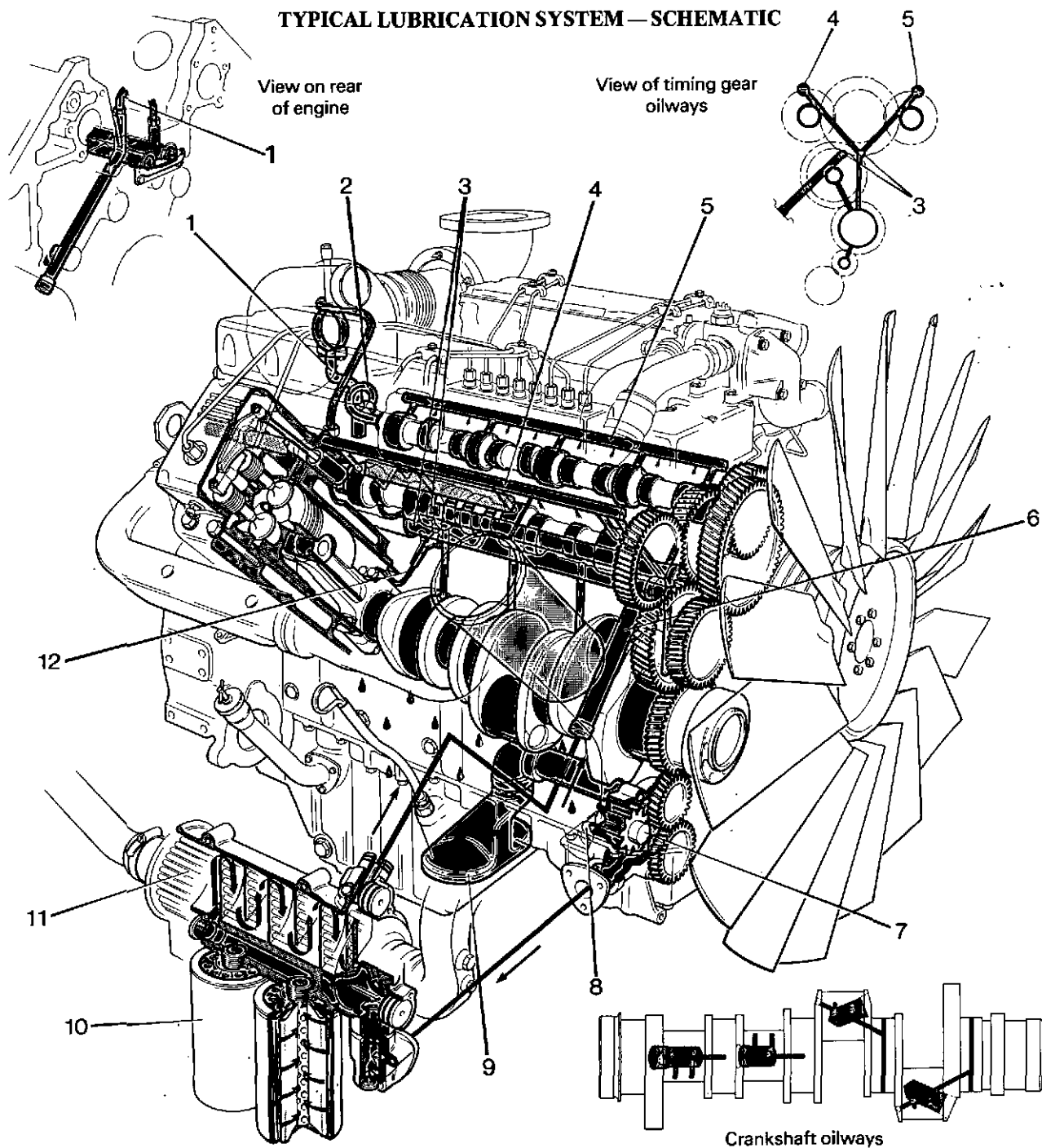

Fig. 2 Lubrication system.

- 1. Turbocharger oil return
- 2. Injection pump/governor oil return
- 3. Main and transfer oil galleries
- 4. 'A' bank auxiliary gallery
- 5. 'B' bank auxiliary gallery

- 6. Inlet from heat exchanger
- 7. Oil pump
- 8. High pressure relief valve
- 9. Suction strainer
- 10. Parallel flow filters

- 11. Oil-to-coolant heat exchanger
- 12. Piston cooling jets

- - High pressure system
- ▨ - Restricted flow system
- - Suction, spill and splash lubrication

heads into the central rocker pedestals. The oil is fed into the hollow rocker shafts, to the rocker arm bushes and thence through the rocker arms to the contact areas. Oil running down each pushrod, together with oil splashed from the cam lobes, lubricates the tappets and pushrod feet.

LUBRICATING OIL

Use only a lubricating oil to the grade and viscosity approved by Rolls-Royce Motors Limited for the engine rating and application, (see leaflet T.S.D. 3085 in the pocket at the rear of this Manual).

Change the engine oil and service the filters in accordance with the Servicing Schedule given in the Servicing Manual T.S.D. 3115, and Operators Guide T.S.D. 3120.

OIL PUMP

Removal

1. Remove the sump drain plugs and drain the oil into a suitable container.
2. Release the heat exchanger-to-sump elbow connection and unscrew the setbolts securing the sump to the crankcase; remove the sump.
3. Unscrew the oil pump fixing bolts and lift the pump from the locating dowels.

Dismantling

1. Remove the drive gear retaining nut and tab washer and, using a suitable puller, withdraw the gear.
2. Unscrew the six through setbolts and remove the oil pressure relief valve casing.
3. Withdraw the driving shaft and idler gear.
4. Press out the idler gear shaft from the front of the pump casing.

Inspection

1. Wash all components in clean paraffin.
2. Carefully inspect the casings, gears and bearing surfaces for wear and damage. Minor blemishes and burrs may be removed by careful stoning. Worn parts must be renewed.

Assembling

1. Press the idler gear shaft into the pump casing, from the rear side, until it comes against the shoulder.

2. Assemble the drive shaft and idler gear in position.
3. Fit the oil pressure relief valve casing to the pump, ensuring that the ring dowel is correctly located. Tighten the casing setbolts evenly to a torque loading of 21 Nm (16 lbf. ft.).
4. Check the drive shaft end float, this should be approximately 0.15 mm (0.006 inch).
5. Fit the drive gear to the shaft, using a new tab washer, and tighten the retaining nut to a torque loading of 120 Nm (89 lbf. ft.). Tab up the washer.

OIL PRESSURE RELIEF VALVE

The oil pressure relief valve is a non-adjustable type fitted in the oil pump rear casing, and has an opening pressure of 415 kN/sq. m (60 lbf/sq. inch). To remove the plunger and spring, depress the spring, using Tool VT 18386, and withdraw the-split pin. Remove the plunger and check the plunger and bore for wear. Inspect the spring for wear and distortion. A new spring conforms to the following requirements:

Free length: 108.75 mm (4.28 inch).

Length under 197.38N (44.38 lbf.) load: 68.64 mm (2.7 inches).

Assembling

1. Lightly oil the plunger and ensure that it slides freely in the casing bore.
2. Fit the spring, together with the spring seating and retain in position with the split pin. It is advisable to always fit a new spring, to ensure correct operating pressure.

OIL-TO-COOLANT HEAT EXCHANGER

Description

The single tube pack type is mounted to the crankcase on the 'A' bank side of the engine. Engine coolant flows through the tubes inside the pack whilst the lubricating oil is diverted over the outside of the tubes. See fig. 2 for the direction of flow.

Removal

1. Drain the both the engine lubricating oil and coolant into suitable individual containers.
2. Remove both the inlet and outlet coolant connections.

3. Release the heat exchanger-to-sump elbow connection.
4. Unscrew the heat exchanger retaining bolts and remove the assembly.

Dismantling

1. Secure the Assembly Fixture, VT 17038, in a vice with both the hand screw assemblies fully out.
2. Position the heat exchanger on the assembly fixture and remove the two tube pack locating screws.
3. Push one hand screw slide fully inwards and twist it into its lock position.
4. Turn the hand screw sufficient to force the tube pack out far enough to remove one 'O' ring seal.
5. Slacken off the hand screw and slide to the original position.
6. Repeat the operation from the opposite end to remove the second 'O' ring seal.
7. Remove the heat exchanger from the assembly fixture and carefully withdraw the tube pack.

Inspection and cleaning

Wash the tube pack in paraffin, blow through the tube bores with an air jet then wash the pack in hot fresh water.

Hard deposits in the tube bores may be removed by soaking the pack in a solution of 1 part inhibited hydrochloric acid to 3 parts fresh water. When the frothing ceases, immerse the pack in a solution of washing soda (sodium carbonate) in hot fresh water 0.5 kg to 25 litres (1 lb to 5 Imp. gallons). Finally blow through the tube bores with an air jet and wash the pack in hot fresh water.

Inspect the tube pack for corrosion or damage and if possible subject the pack to a pressure test by applying air at 172 kN/sq. m (25 lbf./sq. inch) to the tube bores with the pack submerged in water at 80 deg. C.

Assembling

Clean out the housing, push the tube pack through from the rear end until the front groove is clear of the housing and fit a new 'O' ring. Push the tube pack back until the rear groove is visible and fit the other new 'O' ring. Carefully position the pack in the

housing and fit the two small locating screws using new spring washers.

Refitting

Reverse the procedure as previously given for removal, using new 'O' rings and gaskets.

SUMP

Description

The cast aluminium sump has a capacity of 36.3 litres (8 Imp. gallons) with an oil well at the one end, and is reversible for certain applications. A suction intake strainer, fitted in the bottom of the sump, is retained by seven self-tapping screws. The strainer should be removed and cleaned each time the sump is removed.

Removal (Engine installed)

The following procedure should be followed when it becomes necessary to remove the sump:

1. Remove the sump drain plug and drain the oil into a suitable container.
2. Disconnect the heat exchanger to sump connection and remove the oil filler tube and dipstick tube.
3. Support the sump.

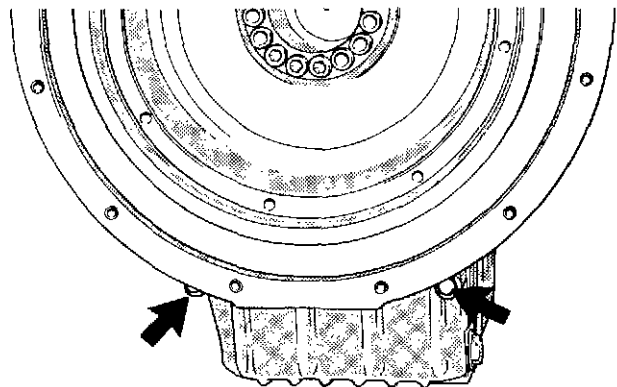

Fig. 3 Sump securing setbolts.

4. Remove the two setbolts which enter the sump through the bottom of the flywheel housing and two similar setbolts through the front engine mounting.

5. Unscrew and withdraw all the setbolts securing the sump to the crankcase.
6. Lower the sump from the engine.

Refitting

The refitting of the sump is a complete reversal of the removal procedure, with added attention to the following points:

Clean the crankcase and sump joint faces carefully, and lightly coat the faces with Wellseal.

Screw two Guide Studs VT 17846 into two holes in the crankcase and fit a new sump gasket in position.

Lift the sump into position over the guide studs, taking care not to disturb the gasket. Secure the sump in position with the retaining setballs and tighten to a torque loading of 55 Nm (40 lbf. ft.).

Fit new gaskets to the heat exchanger and oil filler connections.

Fit a new sealing washer to the sump drain plug and tighten the plug to a torque loading of 110 to 115 Nm (80 to 85 lbf. ft.).

Fill the sump with the approved grade of oil to the UPPER mark on the dipstick. Start the engine and run for a few minutes.

Stop the engine and check for leaks.

Check the oil level and replenish to the UPPER mark on the dipstick, if necessary.

2. Clean the contact faces of the filter header and fill the new filter with the approved grade of lubricating oil.
3. Screw the filter into position until the rubber sealing rings *just* contact the seal face of the header. Tighten the filter a further three-quarters of a turn by hand. **DO NOT OVERTIGHTEN.**

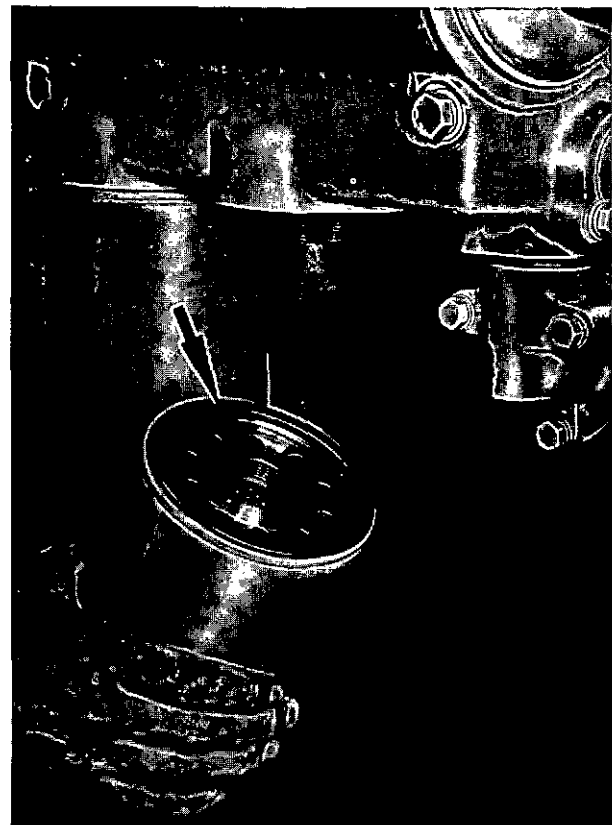

Fig. 4 Oil filter and sealing ring.

OIL FILTERS

Description

Two expendable canister type filters are mounted beneath the header bracket, which is an integral part of the oil-to-coolant heat exchanger casing.

Each canister has a built-in by-pass valve which, if the element becomes blocked, opens to allow a continuous flow of oil through the system.

Filter replacement

Filters should be renewed at the periods given in the Servicing Manual T.S.D. 3115. If however it is necessary to replace filters in service the following sequence should be followed:

1. Place a container beneath the heat exchanger and remove the faulty filter, using the Filter Wrench, VT 18038, if necessary.

4. Fill the sump to the UPPER mark on the dipstick with the approved grade of oil, and start up the engine.
5. Stop the engine, check the oil level, and replenish to the UPPER mark on the dipstick, if necessary.

SPECIAL TOOLS

Part No.	Description
VT 17846	Guide stud, sump to crankcase.
VT 18386	Removal tool, oil relief valve spring.
VT 17038	Fixture assembly, heat exchanger.
VT 18038	Wrench, oil filter.

SECTION 13—INDUCTION/EXHAUST SYSTEM

Description

The induction system of the engine is supplied with air under pressure by means of a Holset type 4LGK turbocharger driven by the energy of the waste exhaust gases.

Cast iron manifolds direct the exhaust gases to the turbine wheel of the turbocharger rotor causing the rotor to spin. The turbocharger compressor wheel, which forms part of the rotor assembly draws air through the air cleaner and delivers it to the induction manifolds, under pressure, to be distributed to each cylinder as the inlet valves open.

Some engine applications require the use of charge coolers, which are interposed between the turbocharger and the induction manifolds and serve to lower the temperature of the compressed induction charge prior to it passing into the engine.

Air to air charge coolers are normally used and these form part of the radiator matrix.

The compressor directs air through pipework incorporated in the radiator to be cooled, together with engine coolant. The cooled air is then delivered via large bore pipework to the induction manifolds.

TURBOCHARGER

Description

The turbocharger is a turbine driven compressor which utilises the energy of the exhaust gases to increase the mass of the induction charge.

The unit consists of a core assembly which houses the rotor assembly and bearings and to which is secured the turbine housing and the compressor cover.

The rotor bearings are of the fully floating sleeve type. Lateral location of the rotor and control of end float is achieved using a shaft mounted thrust ring assembly and a thrust bearing plate. Drillings in the core assembly direct oil to the bearings and the thrust bearing, the rotor assembly is sealed at each end by piston ring type seals.

Dismantling (See figure 1)

1. Clamp the unit upright in a vice, grip on the turbine inlet flange.
2. Mark the relative positions of turbine housing, core assembly, compressor cover and 'V' clamp.
3. Remove the setbolts securing the compressor cover, lift away the cover.
4. Remove the 'V' clamp locknut and spring the 'V' clamp back on to the core assembly. Lift the core assembly away from the turbine housing.
5. Using a ring spanner on the turbine wheel hub, hold the rotor and remove the compressor wheel locknut.
6. Slide the compressor wheel off the shaft.
7. Using circlip pliers, remove the compressor insert retaining ring.
8. Using two screwdrivers, lift the insert from the core assembly and remove the 'O' ring seal.
9. The individual parts of the thrust assembly can then be removed:
 - a. Flinger sleeve, to be gently pushed out of the insert.
 - b. Oil deflector, positioned by two groove pins.
 - c. First Thrust ring.
 - d. Thrust bearing.
 - e. Spacer.
 - f. Second Thrust ring.

Note: The groove pins are a press fit in the core assembly and should not be removed.

10. Remove the shaft and turbine wheel assembly taking care not to damage the piston ring type seals.
11. Remove the turbine backplate retaining ring, using circlip pliers, lift away the backplate.
12. Remove the bearing retaining snap ring from the compressor end of the core assembly.
13. With the finger tip, remove the bearing from the bore.

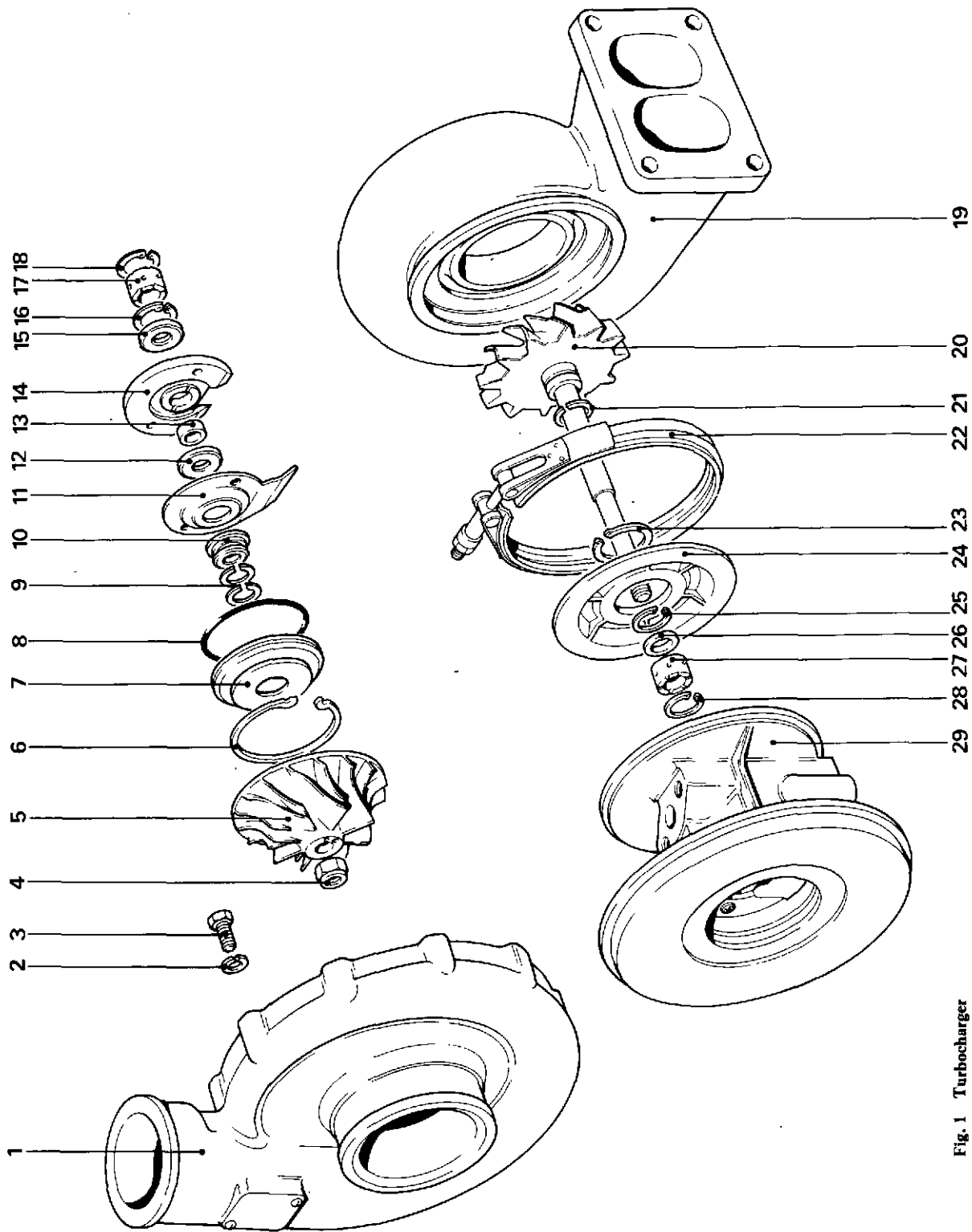

Fig. 1 Turbocharger

14. Remove the inner bearing retaining snap ring from the bore.

Note: When removing snap rings, great care must be taken not to damage the bearing bore.

15. Repeat the above procedures to remove from the turbine end of the core assembly:
 - a. Outer snap ring.
 - b. Oil control sleeve.
 - c. Turbine end bearing.
 - d. Inner snap ring.

Carefully expand and remove the piston ring seals from the rotor shaft and the flinger sleeve.

Note: The over expansion of the piston ring seals will give a permanent set to the seals or cause them to break.

Cleaning

1. Using a suitable non-caustic cleaner, soak all parts until all deposits have been loosened.
2. With a plastic scraper or a bristle brush remove all deposits. Vapour blast may be used provided that the shaft and all bearing surfaces are protected.
3. Clean all drillings with a compressed air jet.
4. Give particular attention to the surfaces of stationary housings adjacent to rotating members, ensuring that these are free from deposits, clean and smooth.

Inspection

1. **Shaft and turbine wheel**
 - a. Inspect bearing journals for wear and

scratches. Minor scratches, those able to be polished out using a mild abrasive are acceptable, well defined scoring and ridges due to wear, render the assembly unserviceable.

- b. Inspect the piston ring seal groove for wear and scoring. Minor scratches only are acceptable. A maximum groove width of 2.0mm (0.078 in.) is acceptable.
- c. Carefully check the turbine wheel for cracked, bent or damaged blades. Do not attempt to straighten bent blades.

2. Bearings

The bearings should be replaced if the surface coating shows any signs of wear or scoring. Only minor scratches are acceptable.

3. Core assembly

Replace the core assembly if the bearing or piston ring seal bores are scored or worn. Minor scratches only are acceptable.

4. Flinger sleeve

Examine piston ring seal grooves and replace sleeve if the grooves are damaged or if groove width exceeds 1.8mm (0.070 in.).

5. Piston ring seals

The seals should be replaced if any sign of wear or scoring is visible.

6. Thrust rings and thrust bearing

Rings and bearings should be replaced if the surfaces show any signs of scoring or pitting.

Minor scratches only are acceptable.

Ensure that the oil feed drilling in the thrust bearing is clean and free from obstruction.

7. Compressor wheel

Carefully check the compressor wheel for cracked, bent or damaged blades. Do not attempt to straighten bent blades.

8. Compressor wheel, shaft and turbine wheel assembly

With the compressor ring wheel mounted on the shaft together with the thrust ring assembly and the whole supported by the bearings on 'V' blocks, a run out of .02mm (0.0008 in.) measured on the outside diameter of the compressor wheel is acceptable.

KEY TO FIGURE 1

1 Compressor cover	16 Snap ring
2 Spring washer	17 Bearing
3 Set screw	18 Snap ring
4 Lock nut	19 Turbine housing
5 Compressor wheel	20 Shaft and turbine wheel assembly
6 Retaining ring	21 Piston ring seal
7 Insert	22 'V' clamp
8 'O' ring insert	23 Retaining ring
9 Piston ring seals	24 Turbine back plate
10 Flinger sleeve	25 Snap ring
11 Oil deflector	26 Oil control sleeve
12 Thrust ring	27 Bearing
13 Spacer	28 Snap ring
14 Thrust bearing	29 Core assembly
15 Thrust ring	

9. 'O' ring seals

The seals should be replaced if they show any sign of deterioration, in particular, flats on the side of the seal, which indicates that the seal has taken a permanent set.

Assembly

Assembly is a reversal of the dismantling procedure. Attention should be given to the following points during assembly.

1. Bearings, thrust assembly, piston ring seals and the rotor shaft should be coated with clean engine oil prior to assembly.
2. When fitting the turbine wheel and shaft assembly into the core assembly, and when fitting the flinger sleeve into the insert, great care must be taken to ensure that the piston ring seals are not entered 'off centre'. Force must not be used.
3. The large insert retaining ring is to be fitted with the bevelled edge facing outwards.

4. Torque figures

- a. Compressor locknut 20 Nm (15 lbf/inch).
- *b. 'V' clamp locknut 13.5 Nm (10 lbf/inch).
- c. Compressor cover set screws 6.8 Nm (5 lbf/inch).

*See Torque Loadings in Section 1, for details.

On completion of assembly, the rotor must spin freely and should be checked to ensure that axial and radial movements are within limits.

End float (See fig. 2) 0.08 to 0.15 mm (0.003 to 0.006 inch).

Radial movement (See fig. 3).

Max. 0.61mm (0.024 inch).

Min. 0.36mm (0.014 inch).

See the Servicing Manual, T.S.D. Publication 3115, for checking details.

Fitting

1. Ensure that the exhaust and induction manifolds are free from dirt and loose articles.
2. Fit new gaskets and ensure that all joints are properly made.
3. Check that the oil supply and drain pipes are clear and undamaged.

4. Ensure that the compressor cover is correctly lined up with the inlet manifold and is not under any strain.
5. Before starting the engine, prime the turbo-charger bearings by pouring 0.2 litre (0.33 pint) of clean engine oil into the priming stand pipe.
6. Tighten all 'V' band clamps to the correct torque loading. See Section 3 for details.

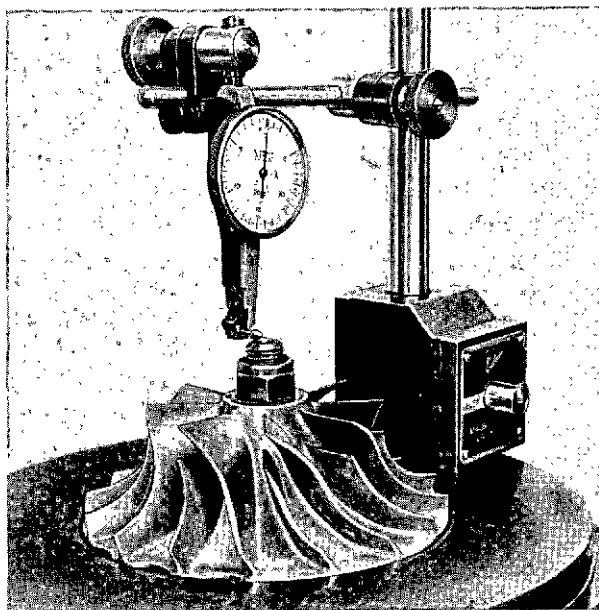

Fig. 2 Checking rotor assembly end float

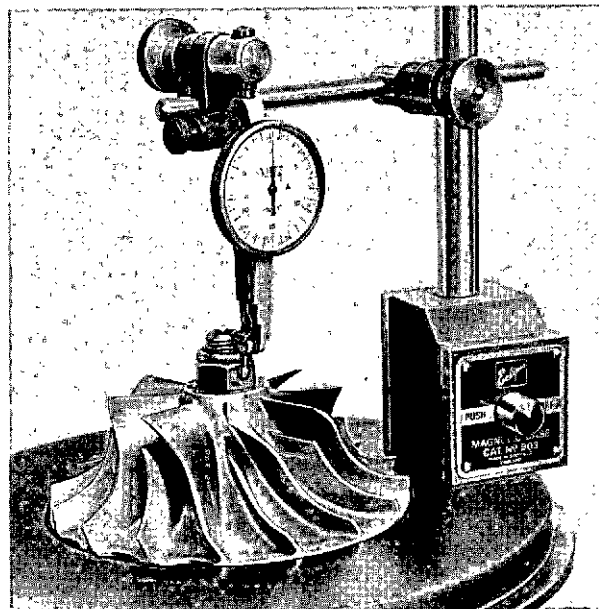

Fig. 3 Checking rotor assembly radial movement.

Note: Refer to 'Turbocharger' in Section 3 for information regarding the protection of turbocharger bearings during test running of engines.

A Standard Overhaul kit, Rolls-Royce Part No. K.R.P. 1158, is available from Rolls-Royce Motors Limited upon request.

The kit comprises:

- 2 Shaft bearings.
- 1 Thrust bearing.
- 1 Oil control sleeve.
- 1 Back plate retaining ring.
- 3 Piston rings.
- 1 'O' ring (insert).
- 4 Snap rings.
- 10 Setbolts with plain and spring washers.
- 3 Gaskets.

Air Cleaners

Two 12 inch 'Cyclopac' paper cartridge type air cleaners are normally fitted to the CV8 engine, the location of which is governed by the particular engine application. Each air cleaner is fitted with a restriction indicator which must be checked daily when the engine is in service.

Full details concerning the servicing of the air cleaners, charge coolers and induction system in general, can be found in the Servicing Manual, T.S.D. Publication 3115.

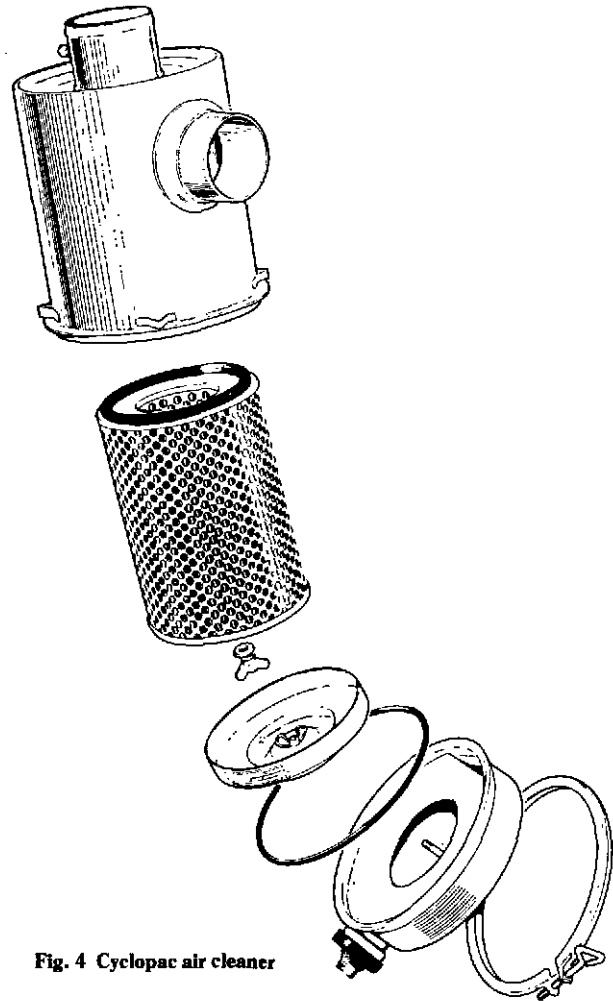

Fig. 4 Cyclopac air cleaner

SECTION 14—ELECTRICAL EQUIPMENT

Description

The starter batteries are provided with a 30 amp capacity charging circuit.

Two types of belt driven alternator can be fitted.

The Butec Type A13 alternator coupled with the Butec Type R1 voltage regulator provide a nominal output of 24 volts, continuously variable over a short range to suit individual application requirements. The Butec Type A 3024 alternator, which can also be fitted, incorporates integral voltage regulation.

Two types of starter motor can be fitted. Both types are flange mounted onto the flywheel housing and engage with a conventional toothed starter ring gear integral with the flywheel.

The C.A.V. Type S130L starter motor is of the coaxial type construction with a two stage operating

solenoid switch mounted around the armature shaft. The alternative starter motor, the Butec Type MS1A, incorporates an externally mounted solenoid.

A C.A.V. Type 368 solenoid unit, used in the energised-to-run mode, is mounted inside the engine 'V' and connected directly to the stop control of the fuel injection pump governor. The solenoid has two coils, a pull-in-coil and a low consumption hold-in coil.

Two Teddington Type DCA switches are fitted into the cooling and lubrication systems and are coupled to the stop control solenoid. The switches provide protection engine shutdown, in the event of coolant temperature or lubricating oil pressure exceeding the permissible ranges.

The switches may be wired to operate on rising or falling pressures and temperatures to suit the individual application requirement.

TYPE A 13 ALTERNATOR

Description

This is a 3-phase delta-connected fan-cooled machine of the rotating field and stationary armature type. Rectification is by six renewable silicon diodes, mounted in two heat sinks across which is a 0.15 microfarad capacitor to smooth transient voltages. Three sensing diodes in a plastic capsule attached to the AC terminals permit the use of a warning light.

The rotor runs in sealed bearings carried in the end housings, and a fan at the driving end of the rotor shaft directs cooling air through the alternator.

Limitations are as follows:

Cut-in speed (alternator rpm)	750
Max. output at 28 volts	30 amps
Max. speed (alternator rpm)	10,000

Voltage regulator (Control board)

The R1 regulator is fully transistorised and requires no servicing. To suit Operators' requirements the output voltage may be varied by means of an adjusting screw, mounted beneath a sealing plug in the regulator cover. Turn the screw clockwise to increase the voltage, and vice versa. Replace the sealing plug after adjustment.

DISMANTLING

1. Hold the pulley with wrench OE 44083 and unscrew the pulley nut. Withdraw the pulley, using extractor OE 44398, and remove the fan. Extract the Woodruff key from the rotor shaft.
2. Remove the brush cover, withdraw the brushes, unscrew the four screws securing the brush housing and remove the housing.
3. Remove the three through-bolts and, using a brass drift, gently tap on the slip ring end of the rotor shaft to part the slip ring end housing from the stator. Disconnect the three AC terminals before fully separating the units.
4. Support the drive end housing and carefully press out the rotor.

INSPECTION AND REPAIR

Stator

Clean the stator by blowing off dirt and carbon dust, and wipe clean using a cloth moistened with

'Genklene' N. When dry, inspect the windings and, using a 12 volt test lamp, make the following checks:

When dry, inspect the windings and, using a 12 volt test lamp, make the following checks:

1. Between each of the three terminals and the stator frame. The lamp should not light.
2. Between each terminal and the other two in turn. In each case the lamp should light.

Bearings

Check the rotor bearings for wear and renew them if necessary. One bearing is retained by a plate in the drive end housing; the other is carried behind the slip rings on the rotor shaft. Both bearings are sealed and do not require lubrication. They should not be removed unless renewal is necessary.

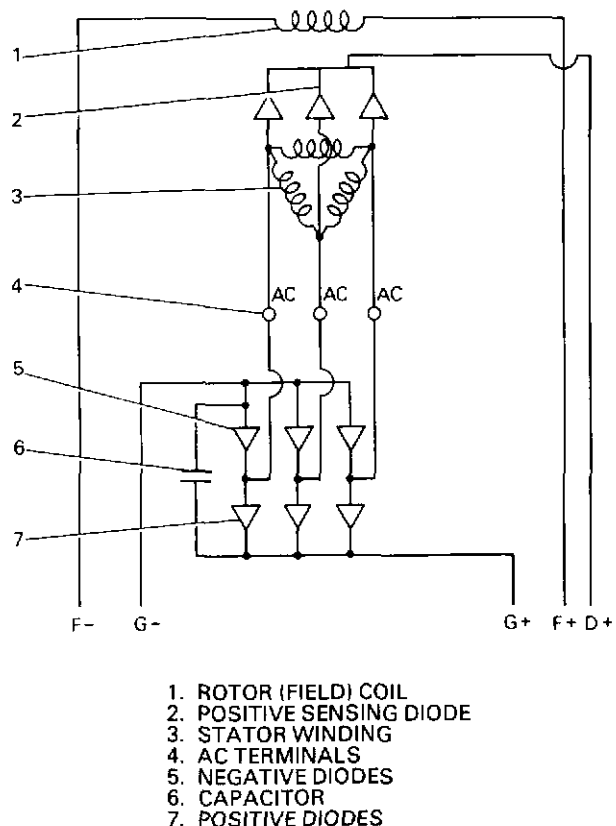
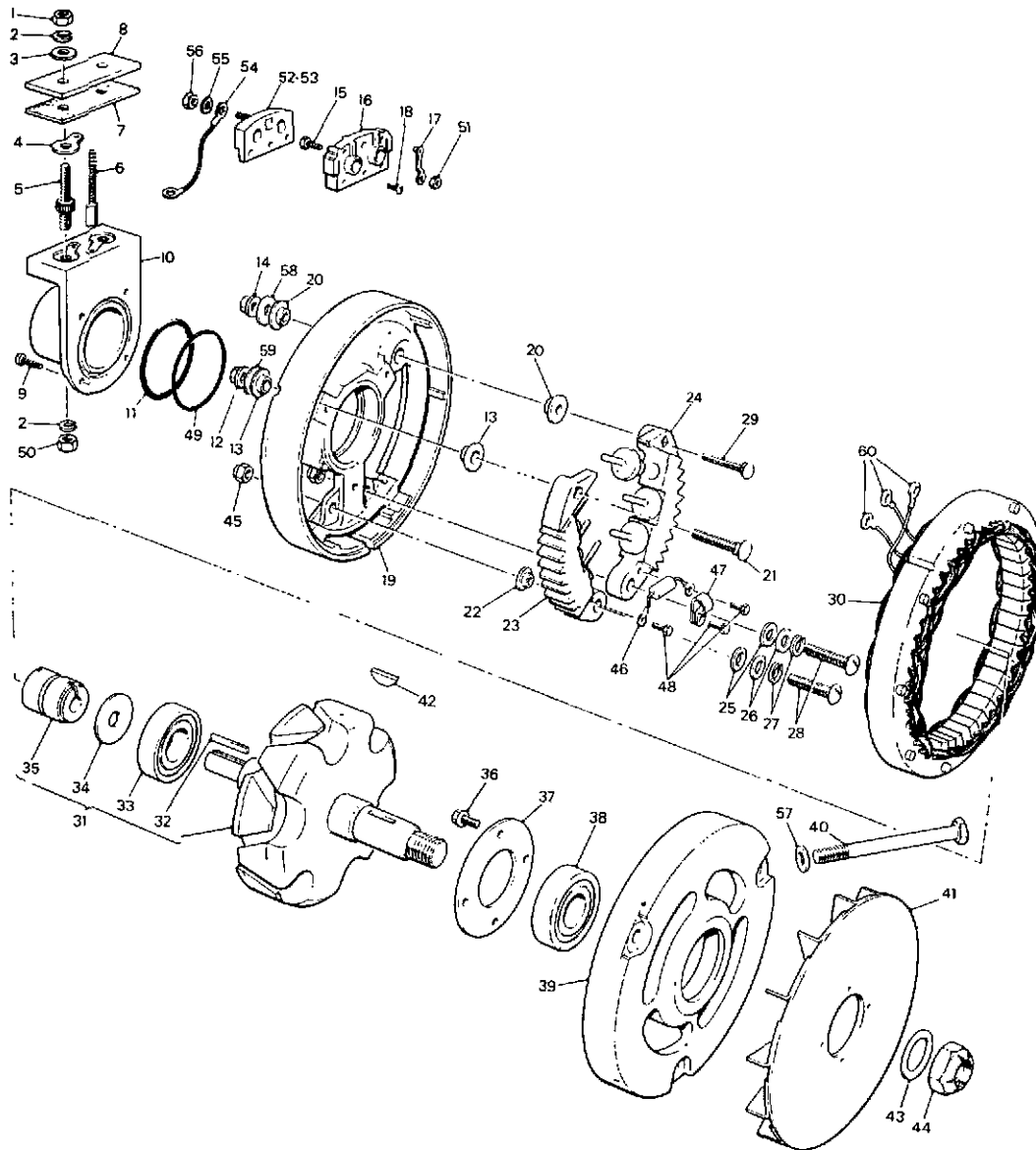

Fig. 1 Butec Type A 13 alternator circuit



- | | | | |
|--------------------|---------------------------|-----------------------|-----------------------|
| 1 Nut | 16 Insulator | 31 Rotor assembly | 46 Capacitor assembly |
| 2 Lockwasher | 17 Jumper assembly | 32 Wedge | 47 Clamp |
| 3 Washer | 18 Screw | 33 Bearing | 48 Screw |
| 4 Jumper | 19 Housing | 34 Insulation washer | 49 Sealing ring |
| 5 Terminal stud | 20 Insulation bush | 35 Slip ring assembly | 50 Nut |
| 6 Brush assembly | 21 Terminal screw | 36 Screw | 51 Nut |
| 7 Gasket | 22 Insulation bush | 37 Retainer-bearing | 52 Diode Capsule |
| 8 Cover | 23 Rectifier assembly (+) | 38 Bearing | 53 Diode Capsule |
| 9 Screw | 24 Rectifier assembly (-) | 39 Housing | 54 Lead assembly |
| 10 Brush housing | 25 Insulation washer | 40 Bolt | 55 Washer |
| 11 Sealing ring | 26 Washer | 41 Fan assembly | 56 Nut |
| 12 Nut | 27 Lockwasher | 42 Woodruff key | 57 Washer |
| 13 Insulation bush | 28 Screw | 43 Washer | 58 Washer |
| 14 Nut | 29 Terminal screw | 44 Nut | 59 Washer |
| 15 Screw | 30 Stator assembly | 45 Nut | 60 Terminal |

Fig. 2 Butec Type A 13 alternator

Rotor

Check the resistance between the slip rings. Limits are 13 to 14.2 ohms. If the resistance is outside these limits, or if the rotor coil is open circuited or earthed, the rotor must be renewed.

Inspect the slip rings for wear and damage. Unserviceable slip rings may be renewed as follows:

1. *Unsolder the wire connecting the rotor coil to the outer slip ring; bend the wire until it is parallel to the shaft and unsolder the wire from the inner slip ring. Pull or press off the slip rings and remove the insulating washer.*
2. Gently warm the new slip ring assembly to avoid cracking during fitting. Assemble a new insulating washer, position the slip ring assembly so that its slots are aligned with the rotor coil wires, and carefully press it up to the shoulder on the rotor shaft. Solder the coil wires to the new slip ring.
3. Set up the rotor assembly in a lathe and take a light, smooth cut from the faces of the slip rings to ensure they are concentric with the shaft within 0.05 mm (0.002 inch) total indicator reading.

Brushes

Renew the brushes if they are damaged or worn beyond the minimum length of 4.8 mm (0.188 inch).

Rectifier

Check each diode in turn, using a 12 volt lamp and

battery between the diode terminal post and the corresponding heat sink, and making each test in both directions by reversing the probes. Failure of a diode involves renewal of its rectifier assembly.

1. If the lamp lights in one direction only, the diode is satisfactory.
2. If the lamp lights in both directions, the diode is 'shorted'.
3. If the lamp does not light in either direction, the rectifier circuit is 'open'.

ASSEMBLING

1. Press the drive end housing on to the rotor shaft.
2. Place the stator in position on the drive end housing and align its bolt holes. Connect the stator terminals to the insulator in the slip ring end housing, place the housing in position on the stator and loosely fit the three through-bolts and their nuts. Carefully press the complete assembly together and tighten the through-bolts to between 7.5 and 9.5 Nm (5.5 and 7.0 lbf. ft.).
3. Fit the brush housing and brushes.
4. Fit the sensing diode capsule and connect the lead wire to the field terminal.
5. Refit the Woodruff key and fit the fan and pulley. Torque tighten the securing nut to 88 to 95 Nm (65 to 70 lbf. ft.). Spin the rotor to check for freedom of rotation.

TYPE A 3024 ALTERNATOR

Description

This is a three phase star connected fan cooled machine of the rotating field and stationary armature type.

Rectification of the output is by six silicon diodes, contained in a rectifier assembly, mounted in the slip ring end housing. Output control is achieved by the use of an integral regulator unit.

Field excitation is provided through three auxiliary diodes mounted in the centre of the rectifier assembly.

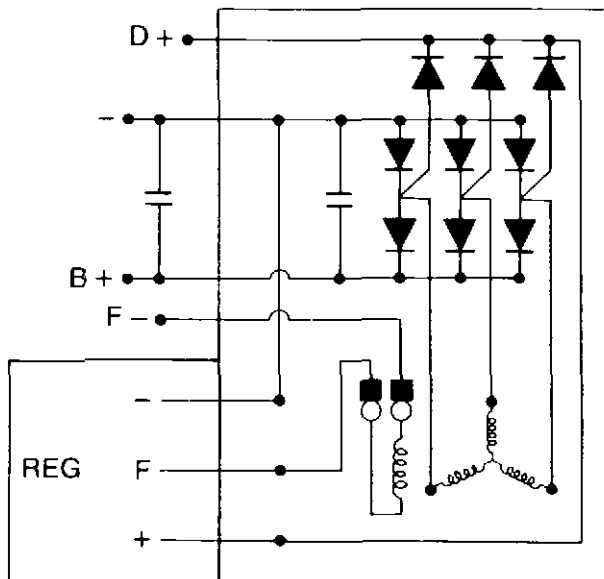

Fig. 1 Typical diagram of connections for the A3024 alternator

DISMANTLING

Before dismantling the alternator mark all housings to ensure the correct relationship during reassembly.

1. Unscrew the fan nut, remove the washer, fan, and drive pulley. Extract the Woodruff key from the shaft and secure the spacer.
2. Remove the suppression capacitor from the main output terminals, release the three screws and lift off the plastic end-cover.

3. Remove the two screws and Belleville washers securing the regulator and disconnect the Lucar terminals, two on the brush box and one on the negative rectifier.
4. Disconnect the remaining Lucar terminal from the brush box and lift out the brush box assembly.
5. Remove the four through-bolts (square nuts located in the drive end housing).
6. Separate the rotor and drive end housing assembly from the stator and slip ring end housing assembly.
7. Remove the three bearing retainer plate screws and, using a gear puller or a press, remove the rotor and the drive end bearing from the drive end housing.
8. Unsolder the three stator wires from the rectifier assembly and separate the stator from the slip ring end housing.

INSPECTION AND REPAIR

All parts should be thoroughly cleaned prior to inspection. Clean by blowing off dirt and carbon dust and wiping with a cloth moistened with 'Genklene' N.

Rotor

1. Check for damage to threads, keyways and bearing surfaces.
2. Using a 110 volt, 15 watt test lamp carry out an insulation test between the slip rings and windings, and the rotor body.
3. Using an ohmmeter, check the resistance of the rotor windings. Resistance to be: 14 ohms \pm 0.2 ohm at 20°C (68°F) ambient temperature.
4. Check that the slip rings are concentric and not worn or scored. If necessary the rings may be lightly skimmed (after checking the tightness of the retaining screw) to a minimum diameter of 24.69 mm (0.972 inch).

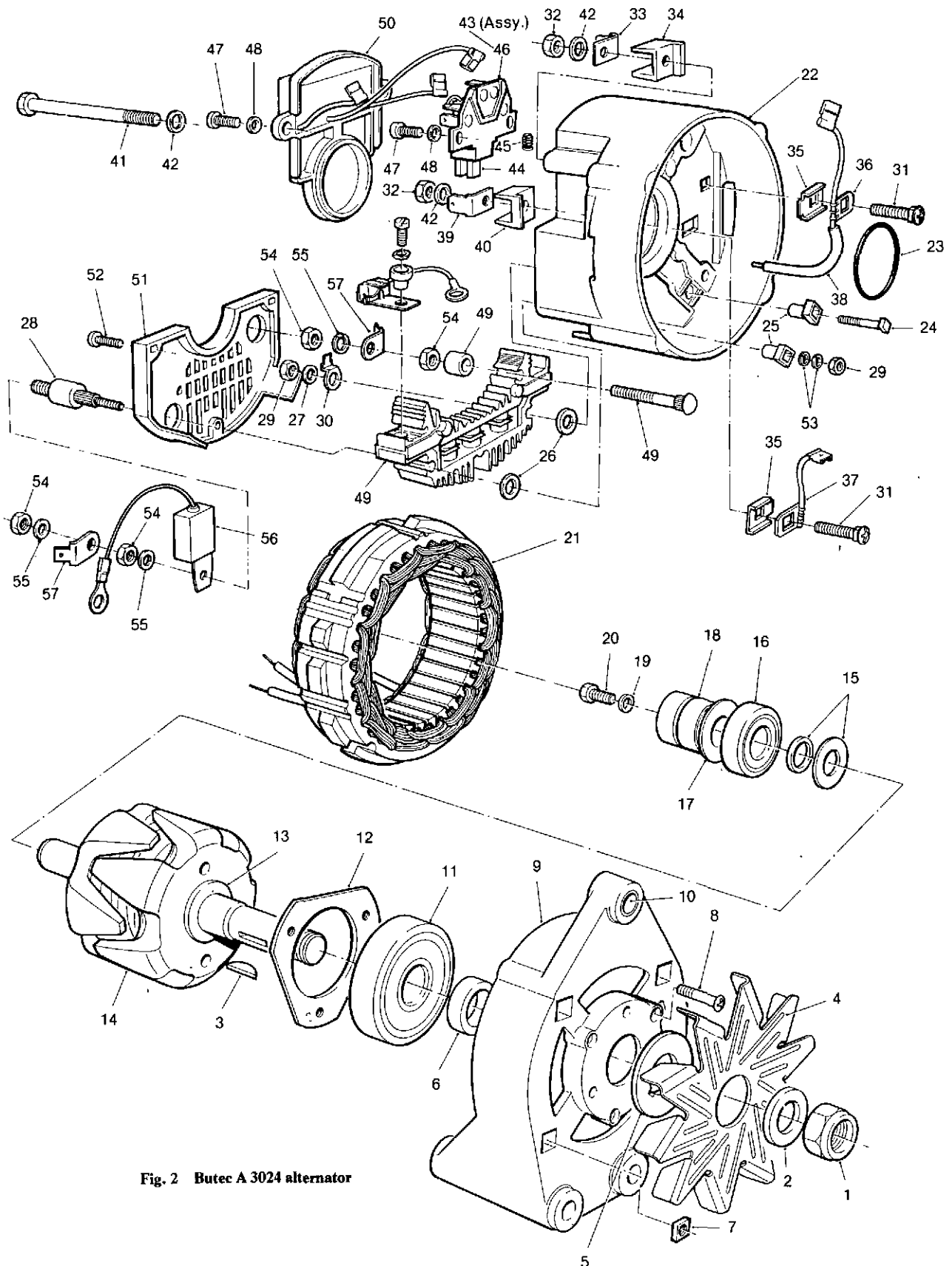

Fig. 2 Butec A 3024 alternator

5. If the slip rings are badly worn or scored they should be replaced as follows:
Carefully unsolder the leads from the slip ring pegs.
Remove the slip ring retaining screw and washer.
Pull the slip ring assembly away from the shaft.
Line up the rotor leads with the slots in the new slip ring assembly.
Press the new slip ring assembly onto the shaft.
Fit the retaining screw and washer. Tighten to 2.3 Nm (20 lbf. inch).
Wrap the rotor leads approximately three turns around the slip ring pegs and solder the joints.
Trim off any surplus peg and cable and remove any surplus solder so that the form of pins and cable can be seen.

Rectifiers and auxiliary diodes

Individual diodes cannot be changed. If a diode is found to be faulty the complete rectifier assembly must be replaced. The diodes can be readily checked by using an ohm meter or a 12 or 24 volt D.C. power supply and a low wattage test lamp.

KEY TO FIGURE 2 (OPPOSITE)

1	Nut	30	Terminal —ve Lucar
2	Washer	31	Terminal, D +, F—
3	Key	32	Nut, D +, F—
4	Fan	33	Terminal, Lucar D +
5	Fan washer	34	Terminal guard D +
6	Distance piece	35	Insulator terminal D +
7	Nut	36	Cable assembly D +
8	Screw	37	Cable assembly F—
9	Housing, D.E.	38	Insulation sheath
10	Liner bush	39	Terminal Lucar F—
11	Bearing, D.E.	40	Terminal guard F—
12	Bearing retaining plate	41	Through-bolt
13	Distance piece	42	Spring washer
14	Rotor assembly	43	Brush box assembly
15	Distance piece	44	Brush
16	Bearing, S.R.E.	45	Brush spring
17	Deflector	46	Brush box
18	Slip ring	47	Screw
19	Spring washer	48	Washer
20	Screw	49	Rectifier assembly
21	Stator assembly	50	Regulator
22	Housing, S.R.E.	51	Cover
23	'O' ring	52	Screw
24	Screw	53	Spring washer
25	Barrel insulator	54	Nut, main terminal
26	Spacer insulator	55	Washer, main terminal
27	Washer	56	Capacitor assembly
28	Terminal —ve	57	Terminal (Lucar)
29	Nut		

To test

Using an ohm meter:

Connect one probe to the rectifier body and the other probe to the three soldered diode connections in turn.

Reverse the probes and repeat this procedure.

These checks should show a low resistance in one direction and a very high resistance in the other, when the probes are reversed.

A low resistance in both directions indicates a short circuited diode.

A high resistance in both directions indicates an open circuit diode.

Using a test lamp:

The bulb should light in one direction only.

If the bulb lights in both directions, the diode is short circuited.

If the bulb does not light in either direction, the diode is open circuited.

Auxiliary diodes

The auxiliary diodes can be checked using the same equipment as for the main diodes. Place one probe on the terminal post (point where D+ cable is soldered) and the other on the three soldered main diode connections in turn. To complete the check reverse the probes.

Slip ring end housing—removing rectifier

1. Unsolder the D+ lead from the auxiliary diode post.

Note: Do not attempt to turn the round section of the negative terminal as this bolt is splined to the negative rectifier.

2. From inside the housing, remove the small nut, two spring washers and the square-ended barrel insulator.
3. From outside the housing remove the small nut, the Belleville washer and the Lucar terminal from the negative rectifier.
4. Remove the rectifier and retrieve the two insulating washers, square-headed bolt and the remaining square headed barrel insulator.

Refitting rectifier

1. From inside the housing locate the square-headed bolt and barrel insulator; place the insulator washer on the bolt from the outside.

2. Fit the insulating washer to the negative terminal bolt on the rectifier and insert it in the housing.
3. Fit the Lucar terminal, Belleville washer and nut to the square-headed rectifier retaining bolt.
4. From inside the housing locate the barrel insulator correctly on the negative terminal bolt, refit the two spring washers and nut and tighten to 3.11 Nm (26.5 lbf. inch).
5. Tighten the rectifier mounting to 2.0 Nm (17 lbf. inch), ensuring that the Lucar terminal has adequate clearance from the auxiliary diode post when the leads are refitted.
6. Solder the D+ lead onto the auxiliary diode post.

D+ and F- leads -removing and refitting

Note: Do not attempt to turn screws from inside the housing.

1. From outside the housing remove the nut, Belleville washer, Lucar terminal and the terminal guard. Remove the screws, terminal, and the terminal insulator from inside the housing.
2. Check the continuity and insulation of D+ and F- leads.
3. From inside the housing fit the terminal insulator, with extension towards the bearing. Fit lead terminal with connecting lugs towards bearing and open ends upward. Correctly locate the squared section of the screw fully into the insulator.
4. From outside the housing fit the terminal guard, Lucar terminal, Belleville washer and the nut, tighten to 3.11 Nm (26.5 lbf. inch).

Brush holder assembly

Check the brush holder for signs of damage, in particular cracking.

Check the brushes for damage and that they are serviceable.

Minimum brush length to be 10.0 mm (0.394 inch).

Brushes—renewal

1. Unsolder the brush leads at the terminal posts and withdraw from holders. Retain the insulating sleeving if serviceable.
2. Fit the sleeving to the new brush leads and thread through the centre of the spring and the

small exit hole.

3. Pull on the brush lead so that a maximum of 15.0 mm (0.590 inch) of the brush is protruding, make one complete turn of the lead around the terminal post and resolder. Trim off any excess lead.

Stator and housing

1. Check the stator windings for burned or broken wires and damage to the insulation.
2. Using a 110 volt, 15 watt test lamp carry out an insulation test between the stator body and each of the three cables in turn.
3. Check the resistance between pairs of leads in turn.
Resistance across two phases to be 0.485 ohms.

Bearings

Bearings are sealed for life and cannot be serviced.

Slip ring end bearing—replacement

1. Remove slip ring assembly—see Rotor section.
2. Remove deflector washer.
3. Using a gear puller or a press remove the bearing from the shaft.
Remove the spacer and the thin washer.
4. Examine the leads, relocate into grooves and refit washer and spacer.
5. Press the new bearing onto the shaft, applying pressure to the inner track only.
6. Replace the deflector washer and refit slip ring assembly, see Rotor section.

Drive end bearing—replacement

1. Using a gear puller or a press, remove the bearing from the shaft.
Secure the spacer and note that the tapered side is towards the bearing.
2. Press the new bearing into the drive end housing, applying pressure to the outer track only.
3. Fit the bearing retainer plate and tighten the three screws to 1.69 Nm (15.0 lbf. inch), using Loctite 242 on screw threads.

Note: Original bearings should be checked for wear or roughness in operation.
The drive end bearing incorporates integral

seals which should be checked for damage or distortion. If there is any doubt as to the condition of the original bearings, new bearings should be fitted.

ASSEMBLING

1. Fit the spacer to rotor shaft with the large diameter next to the rotor.

Press the drive end housing and bearing on to the rotor shaft, applying pressure to the inner track only.

2. Fit a new bearing 'O' ring to the slip ring end housing.
3. Examine the insulation sleeving and renew if necessary. Fit the stator assembly to the slip ring end housing, taking care to align the correlation marks and the through-bolt holes.
4. Carefully fit the rotor and drive end housing assembly into the stator and slip ring end housing assembly, taking care to align the correlation marks and the through bolt holes.
5. Fit the four through-bolts with a Belleville washer beneath the head of each bolt.

Tighten the bolts evenly to the correct clamping torque of 4.9 Nm (44.0 lbf. inch).

6. Refit the brush box assembly, fit the screws and Belleville washers and tighten to 1.69 Nm (15.0 lbf. inch).
Ensure that brushes move freely in their holders.
7. Connect D+ and F— leads to the Lucar terminals as in fig. 3.
Ensure that both leads are located under the internal cast lugs.
8. After making the connections as in fig. 3, fit the regulator, using two screws and Belleville washers. Tighten the screws evenly to 1.69 Nm (15.0 lbf. inch).
9. Bend the negative diode tags down towards the heat sink.
Bend each stator wire down and solder to its tag, together with the auxiliary diode lead.
Tin the underside of each positive tag and bend the tags over the stator wires and solder.
10. Fit the plastic end cover and tighten the three screws to 1.69 Nm (15.0 lbf. inch).
11. Refit the suppression capacitor.

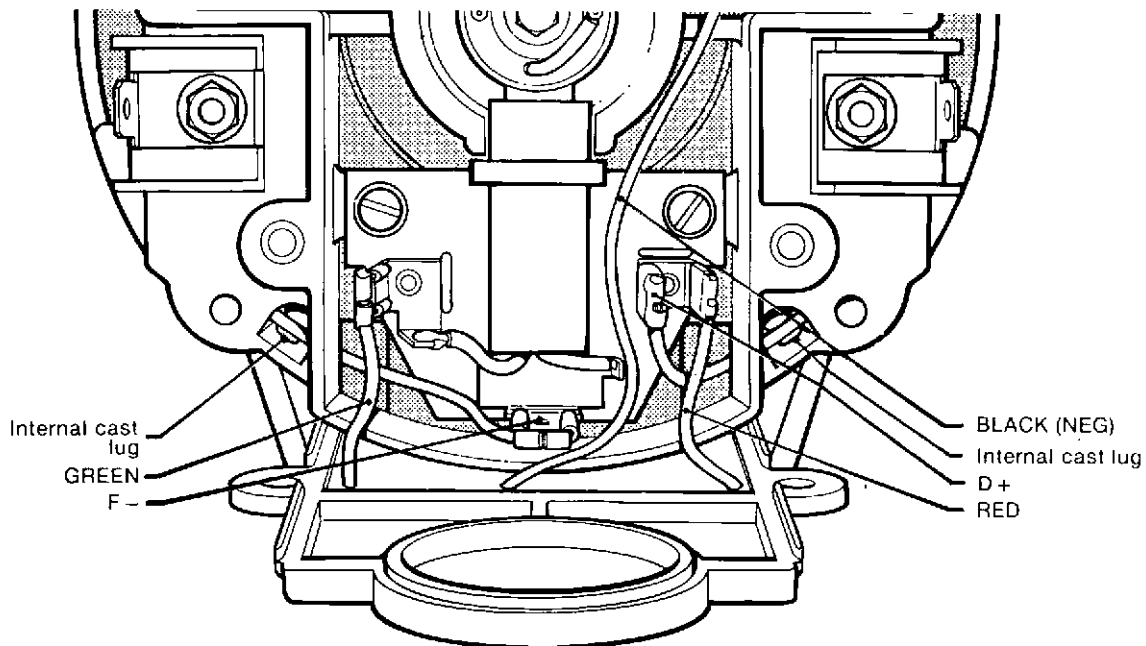

Fig. 3 Regulator connections

STARTER MOTOR (C.A.V. S130L)

Description

The S130L starter is a 24 volt unit of co-axial construction incorporating a two stage solenoid switch unit mounted internally around the armature shaft. It is splash and dust proof and oil sealed at the drive end.

Pinion engagement occurs at reduced power, thereby avoiding heavy engagement shock and excessive wear of the pinion and flywheel ring gear. Full power is applied when the pinion is fully engaged and locked in position to prevent premature ejection.

The battery supply is connected to the main terminals and when the solenoid is energised the pinion assembly moves forward to its first position. The armature rotates under reduced power and when the pinion has almost reached the fully engaged position the second stage contacts close and full battery power is applied. When the pinion sleeve is in the fully forward position it becomes locked.

The pinion speed is rapidly increased by the engine flywheel when the engine starts. A ratchet device then operates, allowing the pinion to rotate at a faster rate than the armature until both are at the same speed; the ratchet then ceases to operate. Should the engine start to drive the armature at a speed in excess of the permitted maximum, an overspeed device will operate to return the pinion to its retracted position.

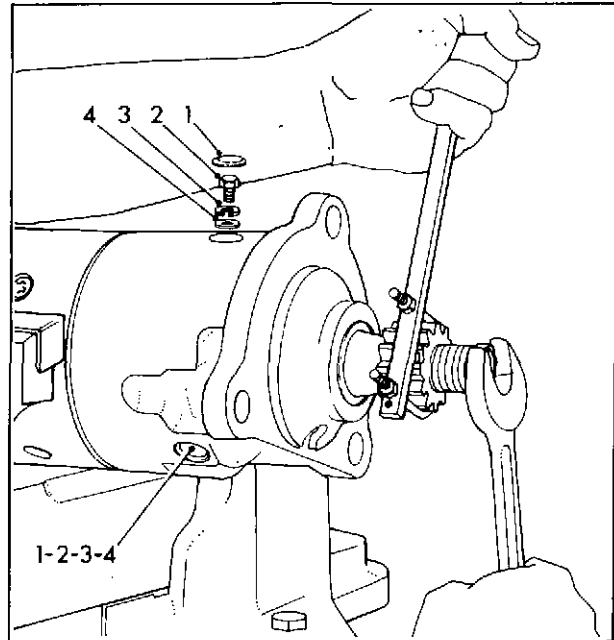

Fig. 1 Loosening pinion stop nut

DISMANTLING

Commutator end shield (fig. 1 and fig. 2).

1. Secure the starter horizontally by the yoke in a soft jawed vice with the large terminal at the commutator end in the 12 o'clock position.
2. Hold the pinion using a suitable tool and unscrew the stop nut two or three turns only. This nut has a left-hand thread. Remove the two core plugs (1) from the drive end shield using a sharp pointed instrument. Unscrew the field terminal screws (2) and remove them together with the spring (3) and plain (4) washers.

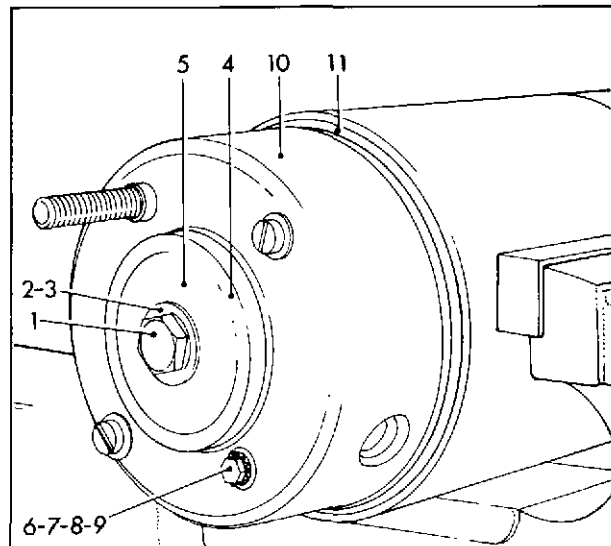

Fig. 2 Removing commutator end shield

3. Unscrew the commutator end terminal nut and remove the washers, seal and insulating bush.
4. Remove the commutator end shield cover, through bolts, and lift off the cover.
5. Hold the pinion as previously described and remove the commutator end bolt (1) fig. 2 together with thrust washer (2) and shims (3). Note the number of shims fitted to the drive end shield and retain them for use when re-assembling.
6. Remove the oiler sealing ring (4) and felt washer (5).
7. Remove screw (6) together with washer (7) washer (8) and bush (9). Remove the commutator end shield (10) and retain shims for use when re-assembling.

Brushgear (fig. 3)

Lift each brush spring (1) fig. 3 in turn and remove the brush (2) from its holder. Remove the screws (3) and spring washers (4) connecting leads and field coil connectors to brush boxes. Complete brushgear assembly can now be removed.

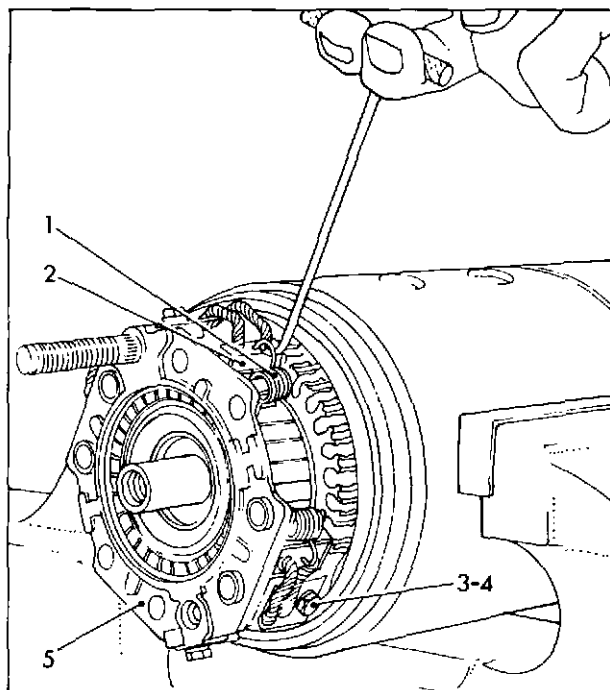

Fig. 3 Removing brushgear

Drive end shield and pinion sleeve (fig. 4 and fig. 5)

1. Tap the drive end shield (1) fig. 4 away from the yoke, using a soft hammer, and withdraw it complete with armature. Support the unit as shown to avoid damaging the windings and commutator.
2. Remove and discard the sealing ring (3).
3. Using a suitable tool remove the oiler core plug (4) and spring.
4. Discard the plug.
5. Remove the yoke from the vice.
6. Clamp the armature horizontally in a soft jawed vice and remove the pinion stop nut, thrust washer and return spring. Release the ball lock mechanism by pushing the end shield towards the armature and unscrewing the pinion sleeve along the helix until it disengages.
7. Slide the pinion sleeve together with the drive end shield off the armature shaft. Retain the eight 5 mm (0.197 inch) steel balls. Place the C.A.V. Tool, No. 6244-50, over the trip plate boss and tighten the clamp screw to secure in position. Invert the complete assembly and clamp the tool (1) fig. 5 in the vice (2).
8. Unscrew the pinion (3) two or three turns using the correct size C.A.V. pinion socket tool.
9. Release the assembly from the vice and remove Tool 6244-50. Unscrew and remove the trip plate together with the lock collar spring and lock collar.
10. Remove the pinion sleeve from the drive end shield.

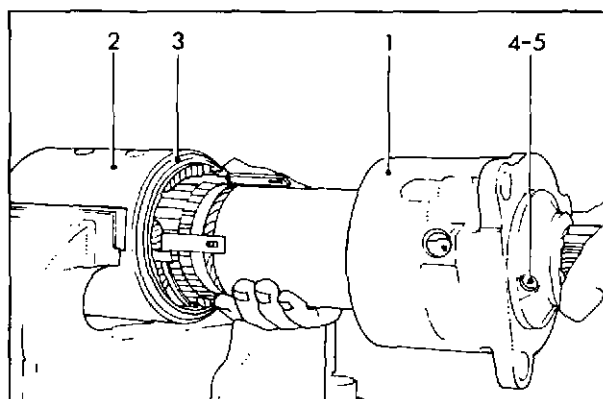

Fig. 4 Removing drive end shield

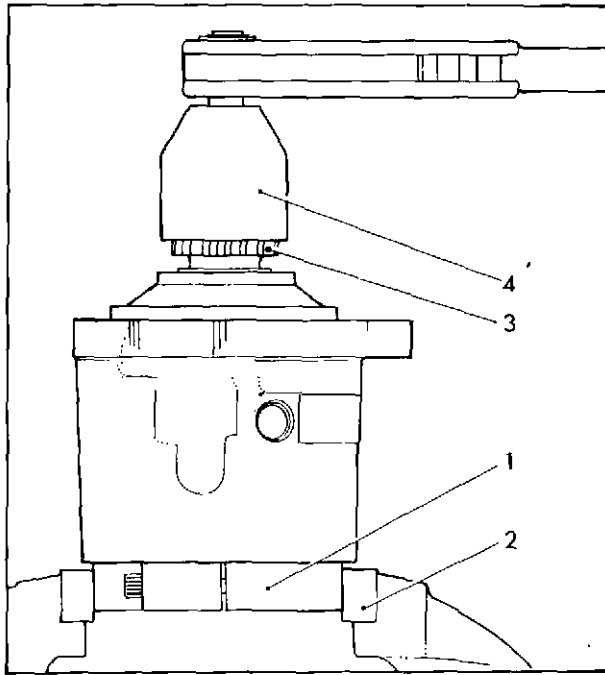

Fig. 5 Removing pinion sleeve

Solenoid switch unit (fig. 6 and fig. 7)

1. Remove screw (1), spring washer (2) and plain washer (3) connecting the flexible lead from the resistor to the moving contact of the switch.
2. Unscrew nuts (4) from the solenoid terminals and remove spring washers (5), plain washers (6), insulating bushes (7) and rubber sealing rings (8). Withdraw the solenoid terminals inwards until they are clear of the resistor plate (10).
3. Remove the resistor (11) and leatheroid insulator (12) from the drive end shield.

Remove main terminal screw (13), spring washer (14), plain washer (15) and two 'Pozi-drive' screws (16) with spring washers (17).

4. Withdraw the switch assembly (18) from the drive end shield and lift out the plunger return spring.
5. Remove 'Spirolox' circlip (1) fig. 7 by levering the end inwards and 'winding' it out of its groove.
6. Remove retaining washer (2) and lift out the four segments (3), together with the garter spring.
7. To remove the main terminal from the drive end shield, unscrew and remove the two nuts, spring

washers, plain washers, seal locator, insulating washer and sealing washer.

8. Lift out the terminal assembly from inside the end shield.

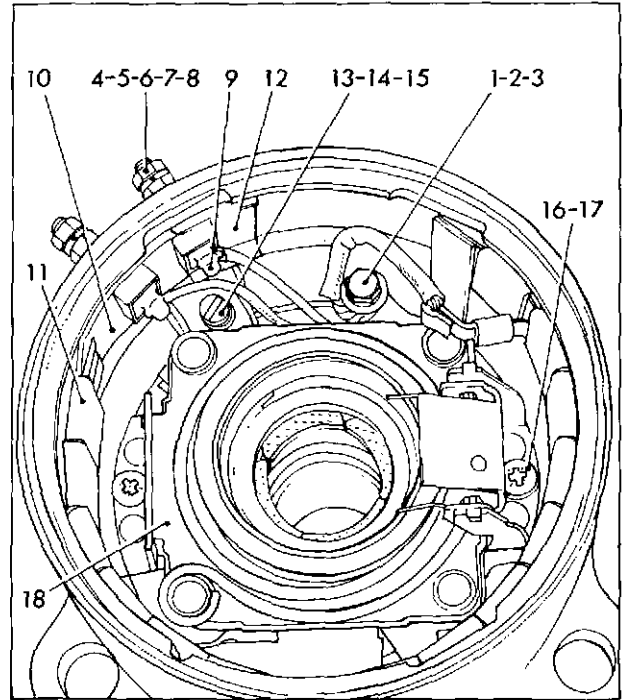

Fig. 6 Removing solenoid switch unit

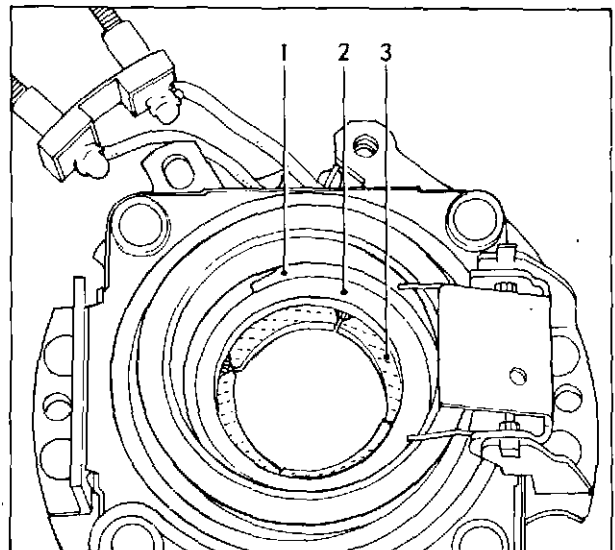

Fig. 7 Removing solenoid plunger segments

Armature (fig. 8 and fig. 9)

1. Lightly clamp the shaft vertically in a soft jawed vice with the commutator uppermost as shown in fig. 8.
2. Remove the recoil housing (1) from inside the commutator sleeve (2). Two holes (3) in the wall of the housing permit the use of two hooked instruments if it is tight in the sleeve.
3. Slide the two annular keys (4) outwards from the groove in the shaft.
4. The armature can now be removed from the shaft, using a twisting movement.
5. Remove the two annular keys, thrust washer (5) and shims (6) from the commutator sleeve together with the thrust washer from the shaft. Retain shims and thrust washers for use on assembly, and remove the shaft from the vice.
6. To dismantle the recoil unit, compress the Belleville washers slightly in a vice using a suitable piece of tubing or rod as shown in fig. 9.
7. Tap the lock plate (1) sideways until the tongue on one side is clear of the groove in the wall. Release the pressure and lift out the lock plate and Belleville washers.

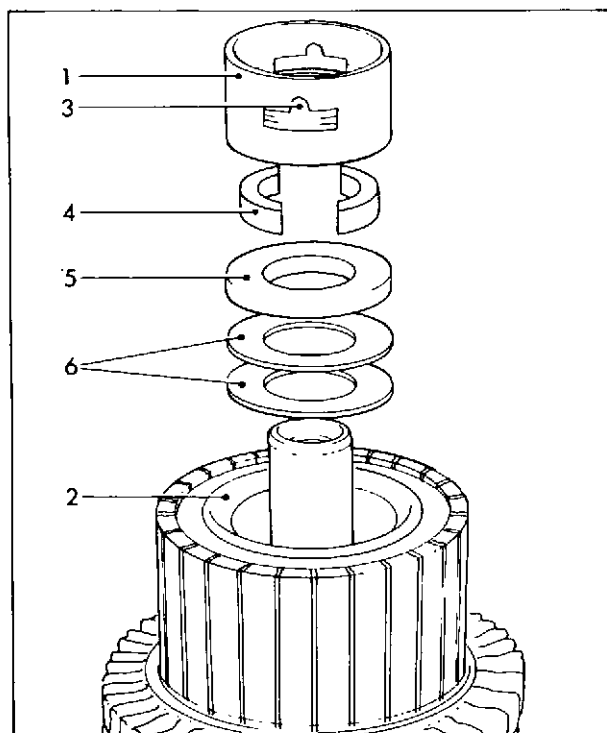

Fig. 8 Removing armature shaft

INSPECTION AND REPAIR

Armature

1. Examine the windings visually for damage and ensure that the bindings are secure and in good condition.
2. Remove all dust with dry compressed air before testing the windings for continuity, shorted turns and insulation, with a 'Growler' armature testing machine.
3. Measure the internal diameter of both bushes. The maximum permissible bore size is 20.075mm (0.790 in.) for the drive end bush and 16.118mm (0.635 in.) for the commutator end bush. If the internal diameter of either bush is greater than these limits, it must be renewed.
4. Remove the ratchet assembly from inside the armature and examine for wear; renew parts as necessary.
6. C.A.V. Tools, Nos. 6244-31, 6244-32, 6244-33, 6244-36 and 6244-37 are necessary for the removal and refitting of bushes.

7. The commutator end bush can now be removed using a suitable extractor. Alternatively, it can be removed by driving it out from the commutator end with a sharp pointed implement.

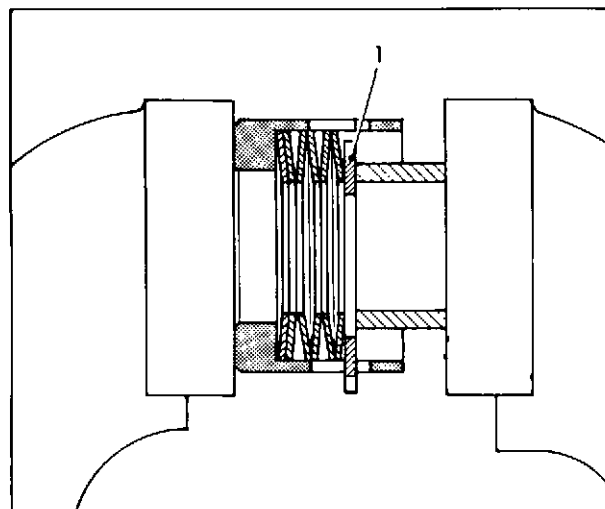

Fig. 9 Dismantling recoil unit

Note: On later machines the hole in the commutator sleeve is increased in diameter to allow the bush to be removed with Tool No. 6244-33.

8. Place the Guide Tool, No. 6244-36, on the Fitting Pin Tool, No. 6244-37, and position the new commutator end bush on the end spigot of the pin. Place the assembly into the armature so that the commutator end bush is just entered into its housing and the guide is in position against the shoulders of the splines. Apply pressure to the end of the pin to press the commutator end bush fully home.
9. Lightly smear the ratchet components with Aero Shell 16 grease, then assemble them into the armature in the following order: Thrust washer (1) fig. 10, armature sleeve ratchet (2), thrust ring (3), helix sleeve ratchet (4), spring (5) and washer (6).
10. Position the new drive end bush on the Fitting Pin Tool, No. 6244-31, and insert the pin into the armature so that the end spigot enters the commutator end bush. Apply pressure to the end of the pin until the drive end bush is fully home. The force required will be 29.42 to 58.84 kN (2.91 to 5.9 ton. f.).
11. Examine carefully the complete armature shaft for signs of wear or damage, paying particular attention to the ratchet and pinion helices and the shoulder of the annular groove for the steel locking balls.

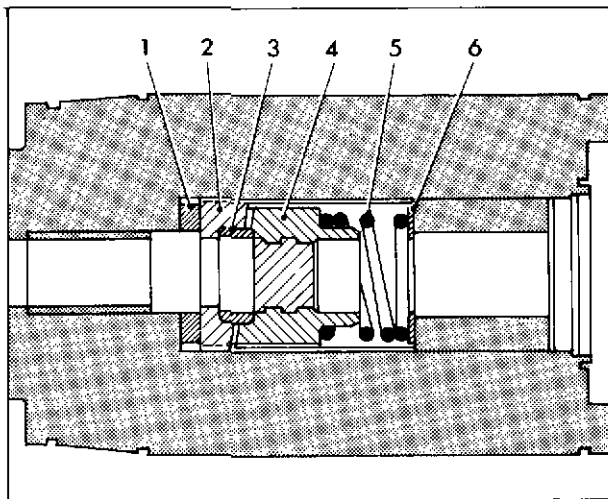

Fig. 10 Assembling ratchet mechanism

12. The commutator can be cleaned with a very fine grade of glass paper. Emery or carborundum paper must NOT be used. If the commutator surface is pitted or grooved it may be set up in a lathe and skimmed to a very fine finish.

Note: The commutator must be concentric with the armature bearings to within $\pm 0.05\text{mm}$ (0.002 inch) and may be machined to a minimum diameter of 58.90 mm (2.319 inch).

13. The full width of the commutator segment insulators should be undercut to a minimum depth of 1 mm (0.040 inch).

Brushgear

1. Remove all dust with dry compressed air and inspect visually for signs of wear or damage.
2. Test the insulation between positive and negative brush boxes using a suitable test instrument; a reading of 1 megohm should be obtained.
3. Brushes should be renewed if damaged or less than 10 mm (0.394 inch) in length.
4. New brushes should be bedded in until 80% of the contact area conforms to commutator curvature.

Drive end shield and pinion sleeve

1. Lever out and discard the bearing bush oil seal.
2. Visually inspect the drive end shield casting for cracks or damage to the sealing ring recess, mounting flange, or threads.
3. Check the bearing for wear and if the internal diameter exceeds 32.10 mm (1.264 inch) the bearing must be renewed as follows:
4. Remove the oiler sealing plug and spring and extract the old bearing with tool No. 6244-41. Discard the felt wick. Position a new felt wick in line with the oiler hole and insert the felt retaining collar tool No. 6244-42 into the bore of the drive end shield to retain the wick while the new bush is being fitted.
5. Blank out the rectangular cut-out in the new bush to prevent swarf getting on the felt wick and press the bush into position in the drive end shield.
6. After fitting, the bush must be fine bored to the correct internal diameter of $32+0.03$ mm ($1.260+0.001$ inch).

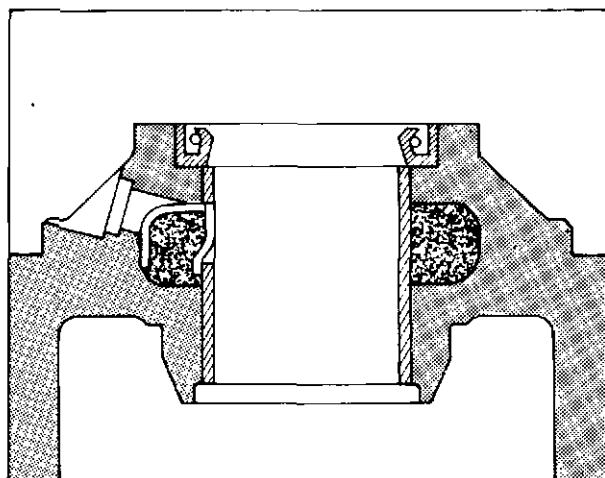

Fig. 11 Drive end oil seal

7. Remove the blanking from the hole in the bush and press in a new oil seal with the lips facing outwards as shown in fig. 11.

Note: If a new end shield assembly is being fitted, the leatheroid pad must be removed from the bearing bush before the starter is assembled.

8. Examine the bearing surfaces of the pinion sleeve for signs of excessive wear or damage. The oil seal in the bore of the sleeve should be renewed when a complete overhaul is being undertaken.
9. Extract the old seal from the threaded end of the sleeve using a hooked implement. The new seal should be inserted into the bore from the same end and eased into its groove using a round ended tool that will not damage the seal lip.

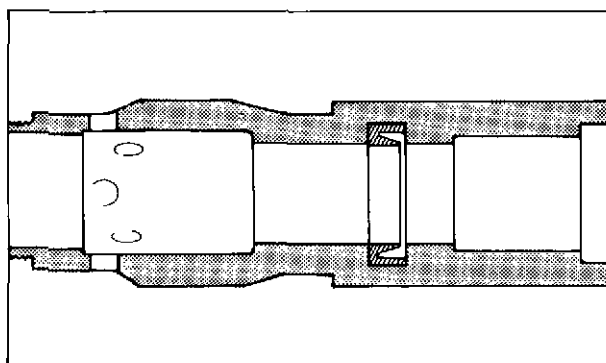

Fig. 12 Pinion sleeve oil seal

10. When correctly installed, the seal lip must be facing towards the pinion teeth as shown in fig. 12.
11. If the pinion teeth show signs of damage or excessive wear, the complete pinion sleeve must be renewed. The new pinion sleeve, complete with oil seal, is available as an assembly.

Solenoid switch unit

1. Inspect the complete unit for damage and excessive wear, paying particular attention to the insulation of coil and leads. Ensure that the insulating bushes are undamaged and the rivets are tight. Check coil continuity using a suitable test instrument or, alternatively, a low voltage battery and lamp wired in series. Test the coil insulation with a 100 volt 'Megger' or similar insulation tester. A reading of 1 megohm should be obtained between the coil leads and plunger sleeve.
2. Should the coil prove faulty the complete solenoid and switch assembly must be renewed.
3. To check that the switch is operating correctly, stand the plunger return spring on the bench and place the solenoid switch unit over it, coil downwards, as shown in fig. 13. Apply downward pressure to the top of the plunger (1) and check that the first stage contacts (2) close.
4. Maintain the pressure and depress the trigger (3); the second stage contacts (4) should now snap together. Hold the coil (5) firmly against the bench and release the downward pressure on the plunger. The moving contact plate (6) should be moved upwards by the plunger return spring so that it locates behind the step on the trigger.
5. Check the condition of both sets of contacts and if necessary clean the surfaces with very fine carborundum paper and wipe over with white spirit.

Note: If the contacts are excessively burnt or they must be renewed as follows:

6. Spring the two arms of the trigger guide (7) apart and remove the trigger complete with spring and spindle.
7. Remove the four rivets retaining the contact stop (8) and remove the contact stop and trigger guide. The moving contact and plunger assembly can now be removed followed by the fixed contact plate.

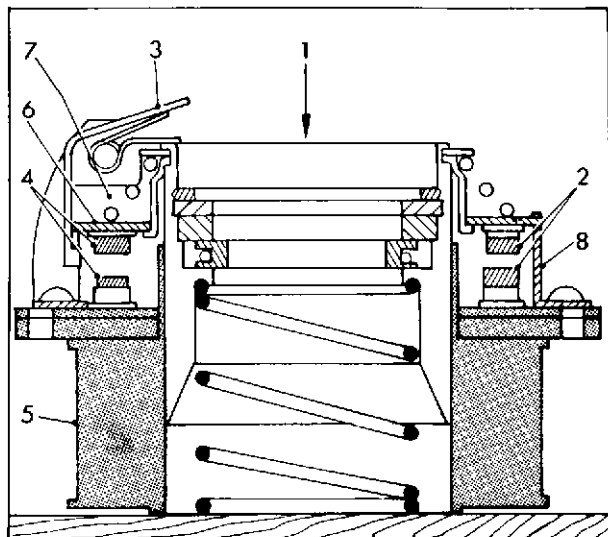

Fig. 13 Checking switch unit operation

8. Remove the four rivets (1) fig. 14 holding the moving contact assembly together and this allows the contact (2) and insulator (3) to be removed from the latch plate (4).
9. When fitting the new moving contact, first assemble the insulator and moving contact to the latch plate, ensuring that the second stage contact (5) is adjacent to one of the two lips (6) on the latch plate as shown.
10. Reassemble with new rivets as illustrated in fig. 14, ensuring that the long insulating bush (7) is passed through the spring eye and is in the position shown.

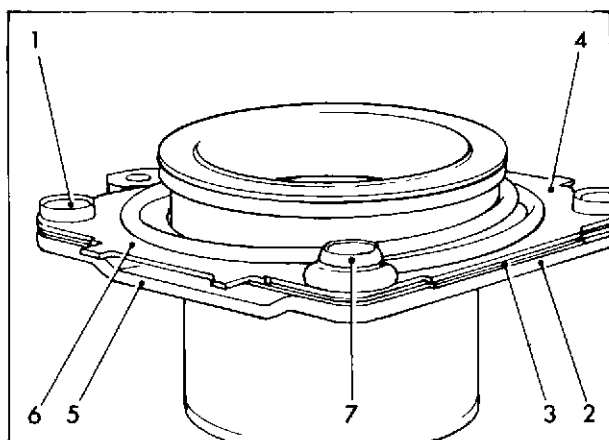

Fig. 14 Renewing switch moving contract

11. During the assembly of the complete switch unit, place the fixed contact plate onto the coil, ensuring the angled slot locates over the raised moulded part of the coil bobbin cheek. Smear the outside diameter of the plunger and the bore of the coil tube with Aero Shell 16 grease.
12. Place the plunger into the tube, ensuring that the moving contacts align correctly with their fixed counterparts. Insert two rivets through the trigger guide moving contact plate and fixed contact plate; rest the rivet heads on a suitable support and punch over the ends.
13. Secure the contact stop in position with two rivets.
14. Position the trigger assembly so that the spring ends rest on top of the plunger and then spring it into position between the guide arms. Ensure that the ends of the spindle enter correctly into the two holes.
15. Check the operation of the complete unit as previously described. Examine the four segments for wear or damage and, if necessary, renew as a complete assembly.

Field coils (fig. 15)

1. Remove all traces of brush dust with dry compressed air. Inspect the coil insulation and insulating strip for signs of damage. Test the insulation with a 100 volt 'Megger' or similar test instrument. A reading of 1 megohm should be obtained between each field coil connection and the yoke. If it is necessary to remove the field coil assembly, proceed as follows with reference to fig. 15.
2. Note the position of both long field coil connectors (1) in relation to the dowel pin (2) at the drive end of the yoke. Unscrew and remove the eight screws (3) securing the pole shoes (4) to the yoke. The field coils (5) and pole shoes can now be removed together with both leatheroid strips (6). When replacing the field coils into the yoke ensure that the long connectors are in the correct position relative to the dowel pin.
3. Place each pole shoe in its correct position with the stamped number on the end towards the drive end of the yoke. When viewed from the drive end, the first pole shoe past the dowel in a clockwise direction, should be number 3, followed by numbers 4, 1 and 2.

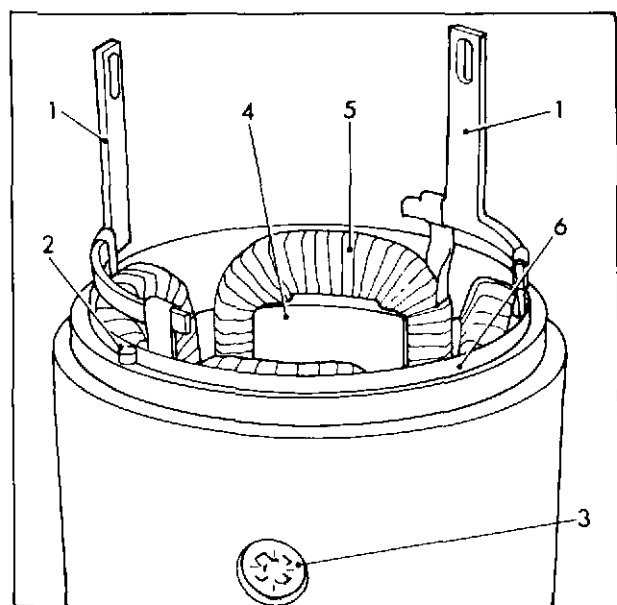

Fig. 15 Dismantling field coils

- Secure each pole shoe with two screws, finger tight only. Place two leatheroid strips under the field coils ensuring they are correctly positioned and then tighten all eight pole shoe screws fully.

Commutator end shield (fig. 16)

- Ensure the bearing is tight in the housing. If the bore of the bearing (1) exceeds 16.087 mm (0.633 inch) the bearing must be renewed.
- Inspect the insulating plate (2) and strip (3) for damage and renew if necessary, securing into position with 'Bostik' Clear Adhesive No. 1437. Ensure that the holes in the strip and plate align

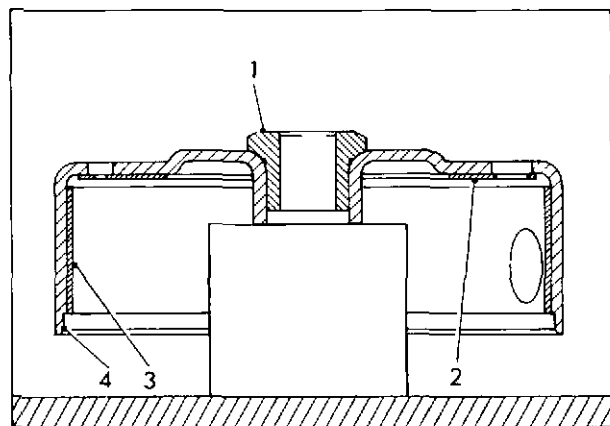

Fig. 16 Commutator end shield bearing

with the holes in the end shield and that the insulating strip does not protrude into the spigot recess (4).

ASSEMBLING

It is recommended that all sealing devices and locking washers are renewed during assembly.

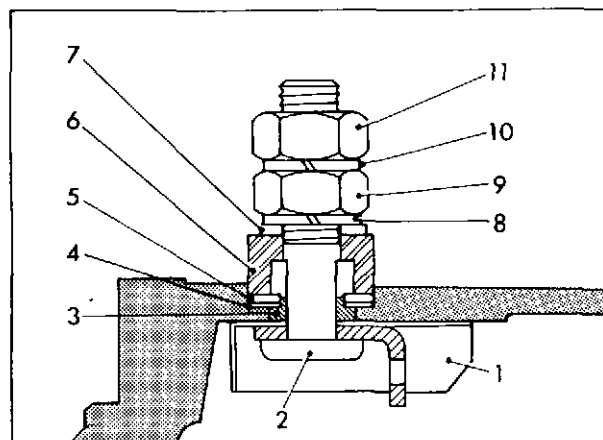

Fig. 17 Drive end terminal assembly

Solenoid switch unit (fig. 17)

- Place the moulded insulator (1) over the terminal (2) as shown and place the sealing washer (3) in position. Pass the terminal through the hole in the drive end shield which has the large counter-bore on the outside. Assemble items 4—7 inclusive in position and secure with the spring washer (8) and nut (9); tighten the nut to a torque loading of 12.2 to 13.6 Nm (9 to 10 lbf. ft.). Place the spring washer (10) in position and screw on the nut (11) finger tight.
- Ensure that the segments and inside of the plunger are clean and free from all oil or grease.
- Assemble the four segments (2) fig. 18 inside the spring (1) and position them in the solenoid plunger. Fit the retaining washer (3) over the segments ensuring that the projections on the underside engage between the segments and that the slot locates over the tongue in the wall of the plunger recess. Insert the Spirolox circlip (4) into the groove in the plunger bore and lightly smear the trigger spring (5) and spindle (6) with Aero Shell 16 grease.

4. Smear the solenoid plunger return spring with Aero Shell 16 grease and place it in the drive end shield. Insert the switch assembly into the shield with the fixed contact connecting arm in line with the main terminal. Fit retaining screws (1) fig. 19 with spring washers (2) and tighten to a torque value of 2.03 to 2.26 Nm (18 to 20 lbf. inch). Insert screw (3) together with washers (4) and (5) and tighten to a torque value of 2.03 to 2.26 Nm (18 to 20 lbf. inch). Fit the leatheroid insulator (6) in the resistor groove and assemble resistor (7) into position in the drive end shield.
5. Fit the insulator (8) over the terminals (9) and insert the terminals through the resistor plate (10), leatheroid insulator and drive end shield. Fit sealing ring (11), insulating bush (12), plain washer (13), spring washers (14) and nuts (15) to each terminal. Tighten to a torque value of 2.03 to 2.26 Nm (18 to 20 lbf. inch).
6. Secure the resistor flexible lead to the switch with screw (16), spring washer (17) and plain washer (18) and tighten to a torque value of 1.69 to 2.03 Nm (15 to 18 lbf. inch).

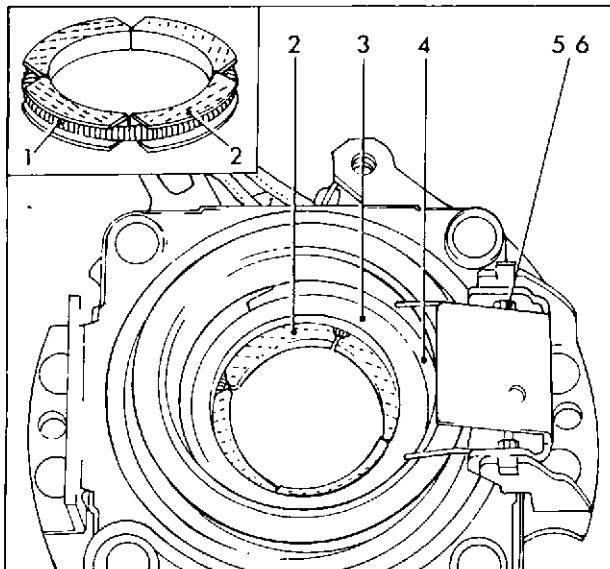

Fig. 18 Assembling solenoid plunger segments

Pinion sleeve

1. Check that the leatheroid pad has been removed from the drive end shield bush.
2. Fit the Collar Tool No. 6244-43 into the drive end seal and lubricate the bearing bore and

pinion sleeve with Tellus T27 oil before inserting the pinion sleeve into the end shield bearing. Remove the split collar when the sleeve is nearly home and guide the sleeve carefully through the four segments.

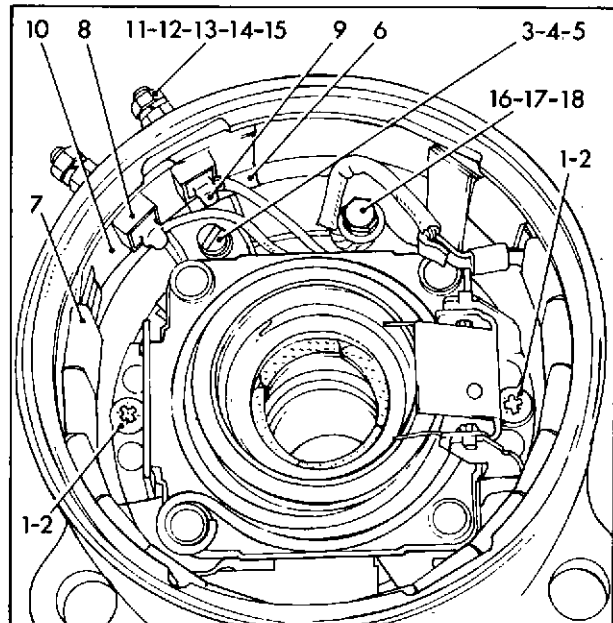

Fig. 19 Replacing solenoid switch unit

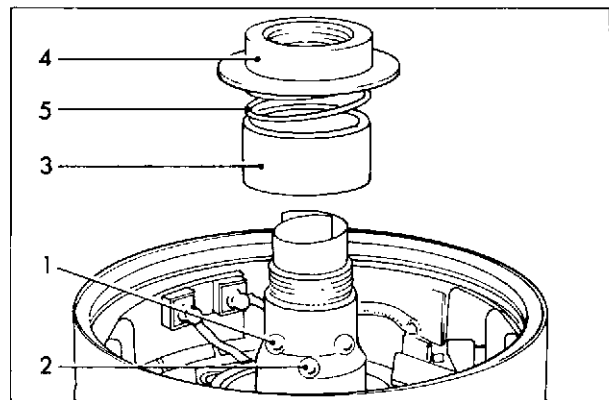

Fig. 20 Assembling pinion sleeve

3. Grip the pinion teeth firmly in a soft jawed vice so that the threaded end is uppermost as shown in fig. 20.
4. Form a piece of stiff paper into a tube and insert it into the pinion sleeve bore to prevent the balls from falling inside.

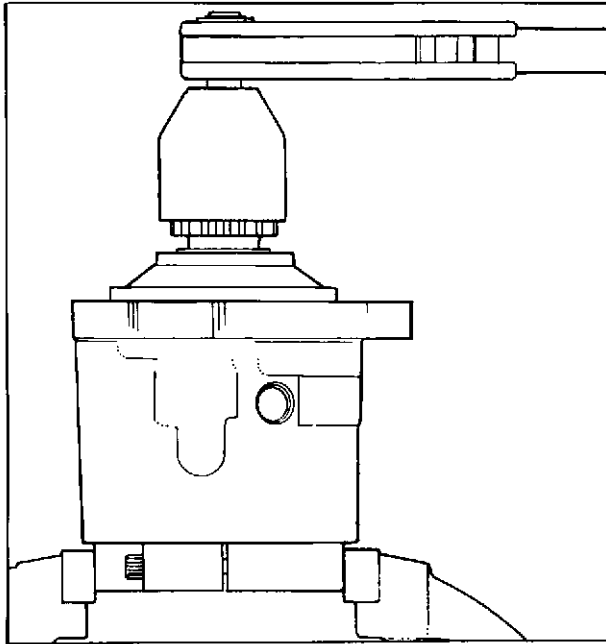

Fig. 21 Tightening trip plate

5. Smear the locking balls (1) and overspeed balls (2) with Aero Shell 16 grease and insert them in the positions shown. Place locking collar (3) in position over the balls.
6. Degrease the threads of the pinion sleeve and trip plate (4) and then smear both threads with 'Loctite' green retaining compound No. 290.
7. Place spring (5) in position and screw on the trip plate finger tight.
8. Secure tool No. 6244-50 over the trip plate boss and clamp the assembly in a vice as shown in fig. 21. Using the correct pinion socket, tighten the pinion to a torque value of 54.2 to 67.8 Nm (40 to 50 lbf. ft.).

Armature shaft

1. Lightly smear the Belleville washers (1) fig. 22 with Aero Shell 16 grease and assemble them into the recoil housing (2) as illustrated.
2. Insert one side of lock washer (3) in the slot in the recoil housing and compress the Belleville washers, as shown in fig. 22, until the lock washer can be engaged in the other slot. Clamp the armature shaft vertically in the vice with the threaded end downwards.

3. Smear the short shaft helix and thrust washer with Aero Shell 16 grease and place the washer on the shaft. Fit the armature to the shaft with a twisting movement to enable the shaft helix to engage with the helix in the ratchet sleeve.

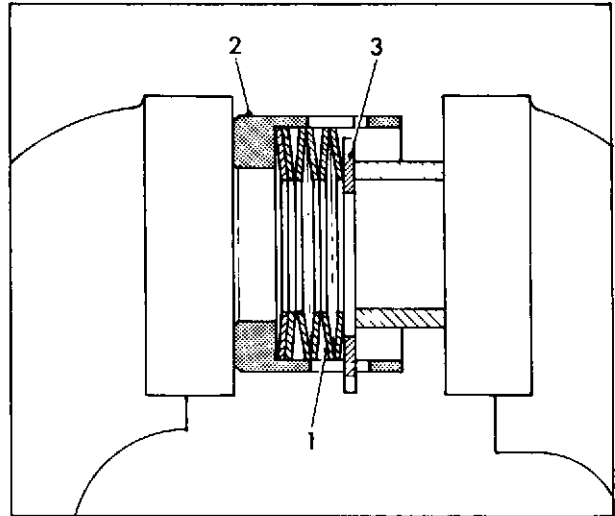

Fig. 22 Assembling recoil unit

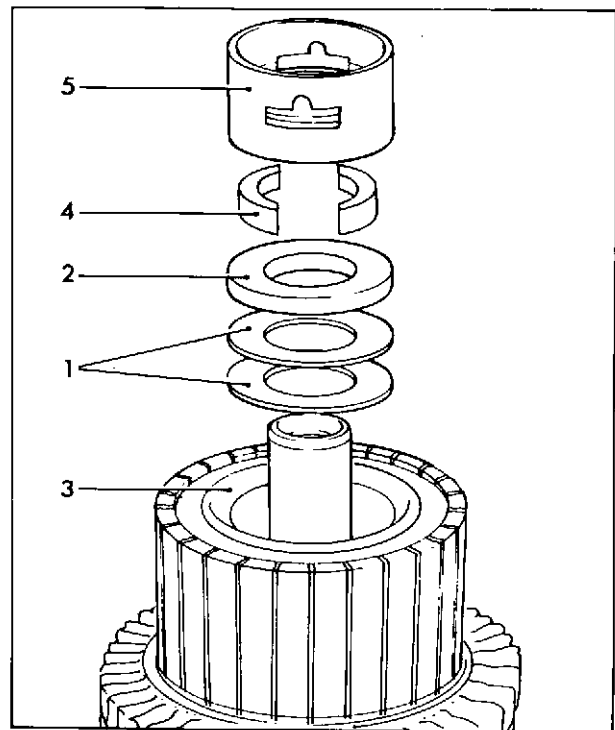

Fig. 23 Replacing armature shaft

4. Smear the original shims (1) fig. 23 and thrust washer (2) with grease and insert, in correct order, into the commutator sleeve (3). Ensure that the shaft is fully home by applying slight downward pressure and fit keys (4) into the annular groove of the shaft.
5. Check the shaft end float while sufficient pressure is applied to the shaft to overcome the reaction of the ratchet spring. The end float should be between 0.05 and 0.35 mm (0.002 and 0.014 inch) and may be adjusted by the addition or subtraction of shims. Use the least number of shims possible and ensure that the thickest shim is next to the keys.
6. Fit the assembled recoil unit (5) into the armature sleeve ensuring that the bore in the lower part locates over the two keys.
7. Check the operation of the ratchet mechanism by turning the armature which should only rotate in one direction.
8. Remove the armature assembly from the vice.

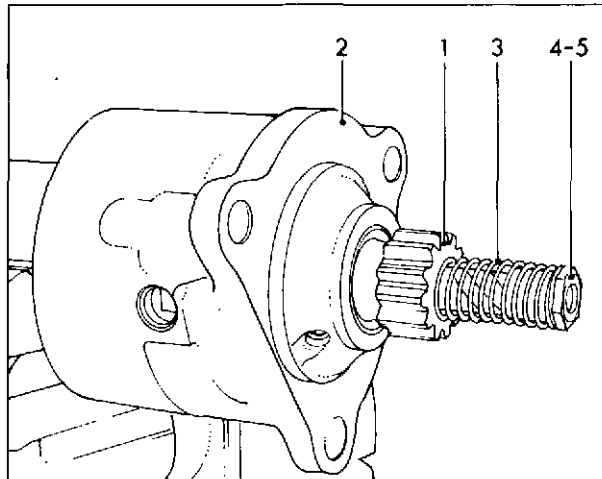

Fig. 24 Assembling drive end shield

Drive end shield

1. Lightly smear helix and bearing surfaces of the armature shaft with Aero Shell 16 grease and clamp the unit horizontally in a soft jawed vice.
2. Pull the pinion (1) fig. 24 fully out of the drive end shield and retain it in this position.
3. Slide the pinion and drive end shield onto the armature shaft and release the pull on the pinion.
4. Remove the paper tube from the pinion before the end shield is fully in position.
5. Fit the pinion return spring (3) and thrust washer (4) and secure with the pinion stop nut (5), finger tight only; remove the armature from the vice.
6. Oil the bearing wick with Tellus T27 oil and fit oiler spring and new core plug.

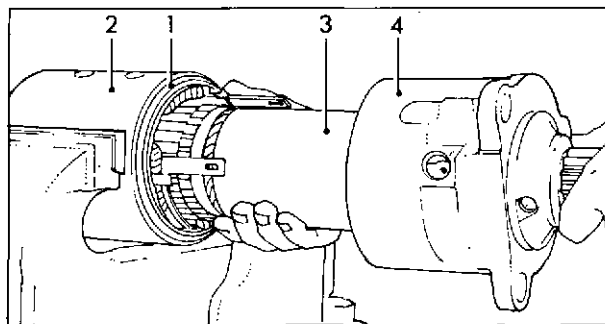

Fig. 25 Replacing armature into yoke

Armature and brushgear

1. Secure the yoke in a vice as shown in fig. 25 and place a new sealing ring (1) in position. Insert the armature (3) while taking care to avoid damage to the windings or commutator. Ensure that the dowel in the end of the yoke engages with the hole in the drive end shield (4). If necessary tap the shield into position with a soft faced mallet.
2. Assemble the brushgear assembly onto the commutator end of the yoke with the large

terminal post (1) fig. 26 in line with the register pip on the yoke end.

3. Fit screw (2) with spring washer (3) through each positive brush lead tag (4) and screw through the brushgear into the brushgear assembly. Do not fully tighten the screw.
4. Insert the brushes into their holders and secure the remaining two unattached leads with screws (5) and spring washers (6), tightening to a torque value of 1.69 to 2.03 Nm (15 to 18 lbf. inch).
5. Smear the original shims (7) with Aero Shell 16 grease and replace them in the recoil housing, thickest shim last.
6. Renew the sealing ring (8).

7. Check brush spring tensions with a gauge as shown. Indicated pressure when the spring starts to leave the brush should read 23.34 to 24.42 N (5.25 to 5.50 lbf.).

Commutator end shield

1. Ensure that both the insulating plate and strip are in position inside the commutator end shield.

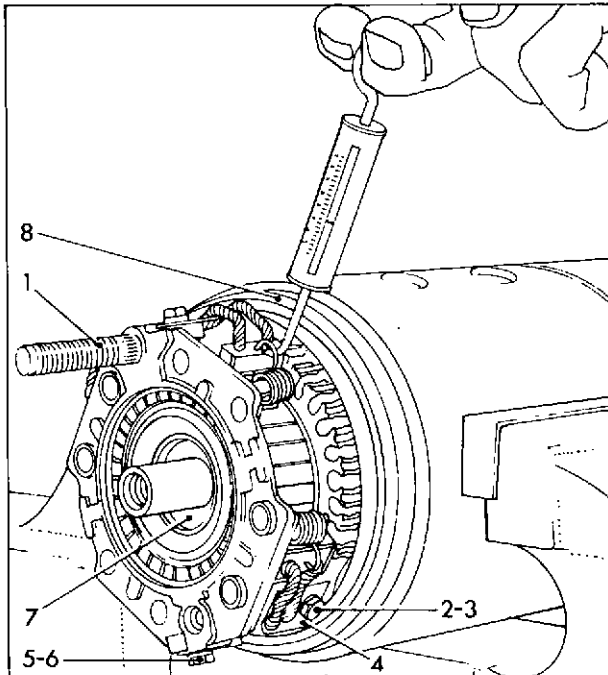

Fig. 26 Replacing brushgear

2. Smear the bush and the end of the armature shaft with Turbo 41 oil.
3. Assemble the end shield (1) fig. 27 onto the yoke, ensuring that it is correctly located and the brush leads are not trapped.
4. Insert both through bolts (2) with sealing washers (3) and tighten to a torque value of 12.9 to 13.6 Nm (9.5 to 10 lbf. ft.).
5. Check the pinion to flange clearance, using Gauge Tool No. 5693-222, by holding the gauge firmly against the flange as shown in inset on fig. 27. With the pinion loaded slightly inwards the arm of the gauge should just clear the face of the pinion. To adjust this clearance add or subtract shims as necessary between the recoil housing and the end shield boss. Shims of vary-

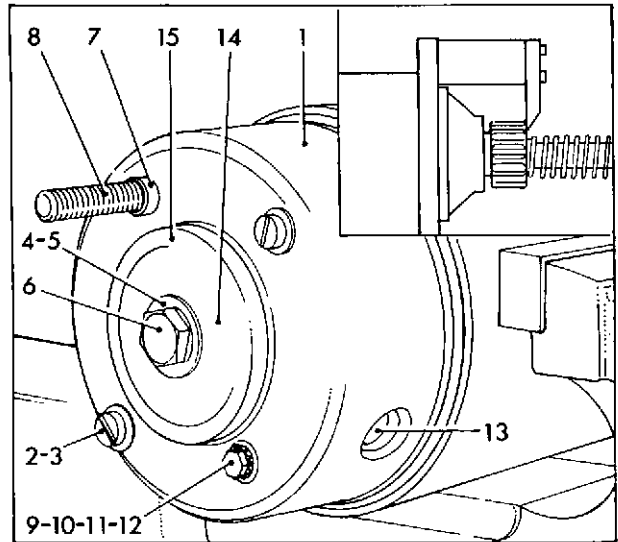

Fig. 27 Replacing commutator end shield

ing thickness are available. Assemble shims (4), thrust washer (5) and bolt (6) and tighten the bolt to a torque value of 34.0 to 40.7 Nm (25 to 30 lbf. ft.) while holding the pinion with Tool No. 6244-39. Add or subtract shims as necessary to obtain a clearance of 0.1 to 0.3 mm (0.004 to 0.012 inch) between the thrust washer and the shims.

6. Hold the pinion and tighten the pinion stop nut to a torque value of 54.2 to 67.8 Nm (40 to 50 lbf. ft.).
7. Slide bush (7) over the return terminal (8) and press fully home.
8. Fit insulating bush (9), plain washer (10), shake-proof washer (11) and screw (12); tighten the screw to a torque value of 1.69 to 2.03 Nm (15 to 18 lbf. inch). Pull on the return terminal (8) and tighten the brush screws (13) through the access holes in the commutator end shield to a torque value of 1.69 to 2.03 Nm (15 to 18 lbf. inch).
9. Remove both through bolts and fit the felt washer (14) and seal (15). Place the commutator end shield cover (1) fig. 28 in position, refit both through bolts (2) with sealing washers (3) and tighten to a torque value of 12.9 to 13.6 Nm (9.5 to 10 lbf. ft.).
10. Fit the thin sealing washer (4), rubber seal (5), seal locator (6), plain washer (7), spring washer (8) and nut (9) on the return terminal; tighten to

a torque value of 12.2 to 13.6 Nm (9 to 10 lbf. ft.). Add a second spring washer and nut to the terminal and screw up finger tight.

11. Insert the two field coil connecting screws, spring washers and plain washers through the holes in the drive end shield and tighten to a torque value of 1.69 to 2.03 Nm (15 to 18 lbf. inch).
12. Fit a new core plug to each hole using Tool No. 6244-45.

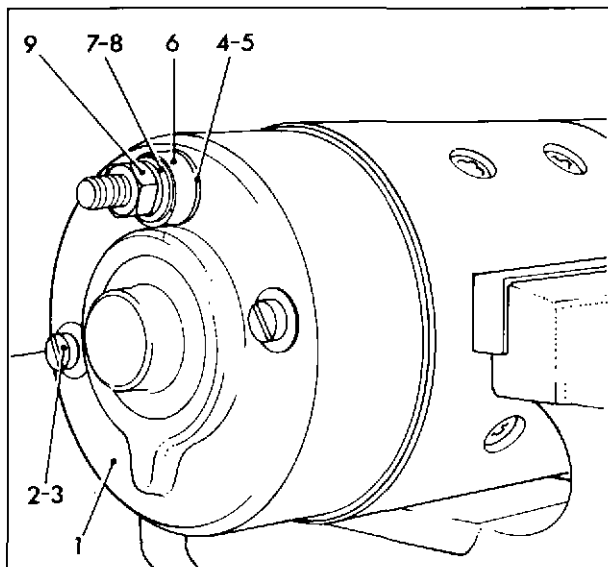

Fig. 28 Replacing commutator end shield cover

TESTING

Check that the pinion will rotate freely when turned by hand and will return easily to its original position when pulled partly outwards and then released.

Note: This check must be carried out before any power supply is connected to the main terminals. Failure to heed this warning could result in serious injury.

Light running test

Secure the starter motor in a suitable position. Energise the solenoid with 24 volts and then connect a 24 volt battery supply to the main terminals for a maximum of five seconds. The pinion should rotate slowly and smoothly with no undue noise or vibration. Disconnect the battery supply from the main terminals. Apply 24 volts to the solenoid terminals and pull the pinion forward into the locked position. Connect the main terminals to the 24 volt supply. In this position the pinion should rotate smoothly at a greater speed than previously.

Disconnect the supply to the solenoid terminals: the pinion should now return to its de-energised position and stop rotating.

Further details of testing may be obtained through an official C.A.V. agent.

STARTER MOTOR (BUTEC MS1A)**Description**

This is a 24 volt machine, actuated by an externally mounted solenoid switch via a lever arm. The pinion assembly incorporates a positive engagement device, an overload clutch and a freewheel ratchet.

OPERATION

Referring to figs. 2 and 3, operation of the starter switch energises the pull-in and hold-in coils, causing the solenoid, via the lever arm, to move the pinion into mesh with the starter ring. If the teeth abut, the pinion rotates slightly until engagement occurs.

The starting contacts then close, in parallel with the pull-in coil which is thus de-energised, and full torque is exerted. If engine resistance is excessive the pinion clutch comes into operation.

When the engine starts, the pinion is enabled by its ratchet to run free, in mesh with the starter ring, until the starter switch is released. The hold-in coil is then de-energised, allowing the return spring in the solenoid switch to disengage the pinion, via the lever arm.

DISMANTLING

1. Remove both jumper leads between the solenoid switch and starter body. Extract the rubber plug from the solenoid base, insert Tool CET 55/105, engage it with the solenoid shaft nut and turn the tool anti-clockwise until the plunger and lever arm are released from the shaft. Unscrew the two remaining bolts and remove the solenoid switch.
2. To dismantle the solenoid switch, remove the terminal nuts, washers and sealing rings. Remove the base and disconnect the coil lead. Unscrew the retaining nut and remove the contactor, spring and associated parts. Withdraw the solenoid shaft and return spring from the opposite end.
3. To dismantle the starter, first mark all housings to ensure reassembly in correct relationship. Remove the brush cover, disconnect the brush tabs and carefully withdraw the brushes. Dis-

connect the two field leads, unscrew the four retaining bolts and withdraw the commutator housing. Remove the nose housing, disconnect the shift lever and remove it together with the pinion assembly. Withdraw the armature and detach the shift housing from the field ring.

CLEANING

Use a cloth moistened with 'Genklene' N to remove dirt and grease. Wash metal parts as necessary, but do NOT immerse the pinion assembly in a solvent since it contains a special lubricant.

INSPECTION, TEST AND REPAIR

1. Using an Avometer, check the resistance of the pull-in coil (1.34 ohms) and hold-in coil (2.7 ohms). Renew the solenoid switch if the coils are defective.
2. Examine the field ring and housings for damage. Using a flash tester at 500 volt setting, check the field coils for insulation failure and open circuits. Renew the field ring if any coil is defective.
3. Inspect the armature for wear and damage, particularly to the splines. Check the shaft for bowing and the commutator for concentricity. Renew the shaft if its run-out exceeds 0.13 mm (0.005 inch). The commutator should have a highly-burnished finish, deep copper in colour and be concentric within 0.08 mm (0.003 inch); if the armature is otherwise serviceable the commutator surface may be restored, subject to a minimum diameter of 52.39 mm (2.062 inches).
4. Using a 'growler' and 230 volt test lamp, check the armature for earthing, continuity and open circuits.
5. Inspect the bushes in the nose housing and commutator end housing. If either bush is to be renewed, align its oil hole and afterwards ream the bore to between 19.10 and 19.15 mm (0.752 and 0.754 inch) diameter.
6. Inspect the bush in the shift lever housing. When renewing, align the oil holes and afterwards ream the bore to between 22.20 and 22.25 mm (0.874 and 0.876 inch diameter).

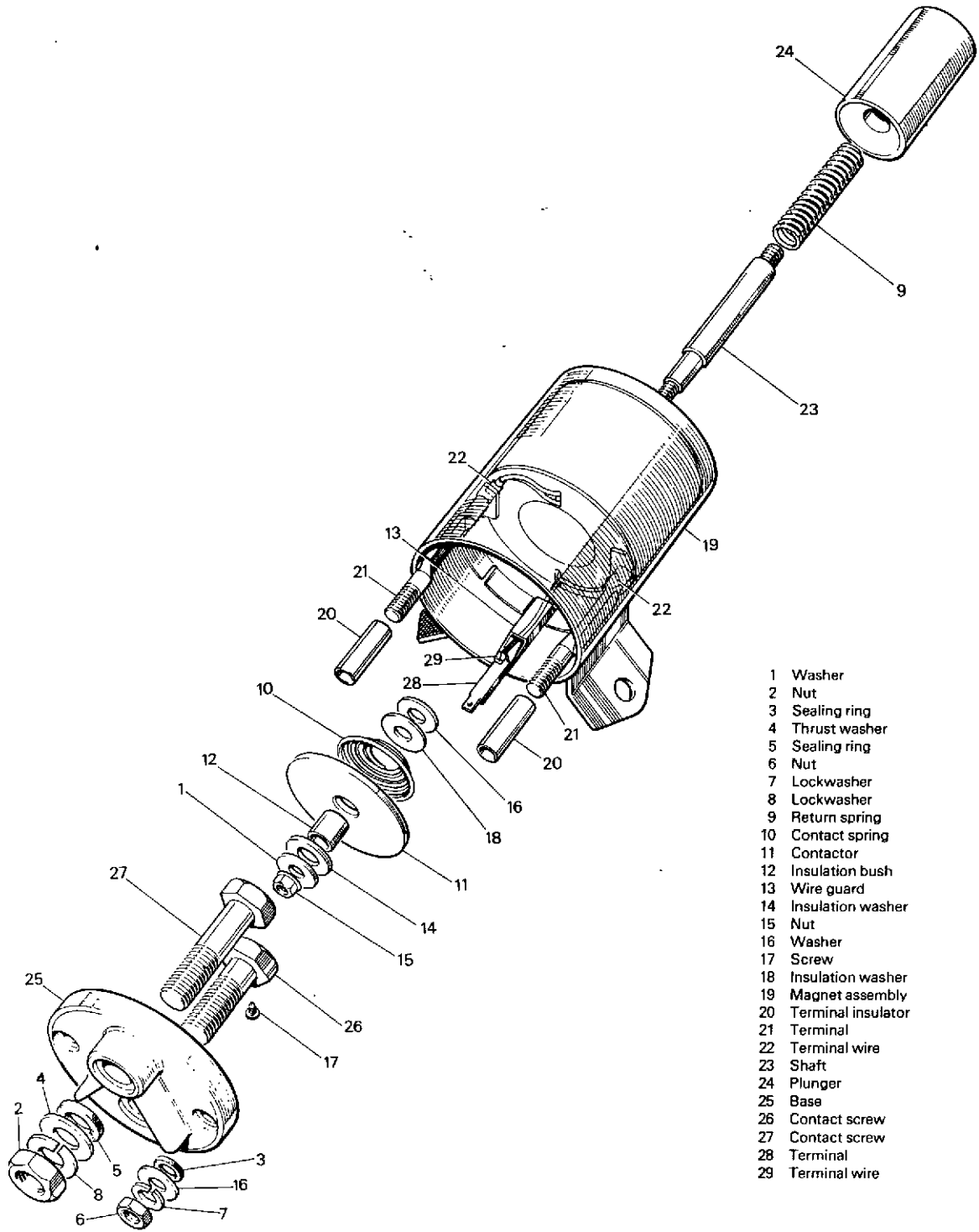

- 1 Washer
- 2 Nut
- 3 Sealing ring
- 4 Thrust washer
- 5 Sealing ring
- 6 Nut
- 7 Lockwasher
- 8 Lockwasher
- 9 Return spring
- 10 Contact spring
- 11 Contactor
- 12 Insulation bush
- 13 Wire guard
- 14 Insulation washer
- 15 Nut
- 16 Washer
- 17 Screw
- 18 Insulation washer
- 19 Magnet assembly
- 20 Terminal insulator
- 21 Terminal
- 22 Terminal wire
- 23 Shaft
- 24 Plunger
- 25 Base
- 26 Contact screw
- 27 Contact screw
- 28 Terminal
- 29 Terminal wire

Fig. 1 Butec solenoid switch

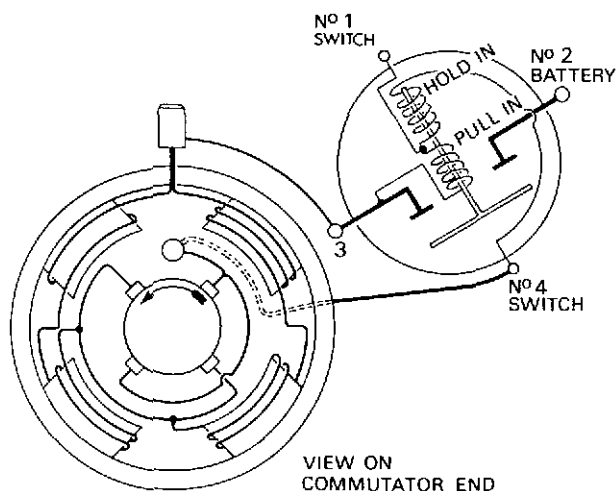

Fig. 2 Butec solenoid switch circuit

7. Examine the lever arm and shaft for wear and damage, and check that the nylon locking insert in the screwed position of the shaft is effective.
8. Inspect the pinion assembly and renew it if excessively worn or damaged.
9. Test the insulation of the brush holders. Renew the brushes if damaged or worn. Minimum length 15.9 mm (0.625 inches).

ASSEMBLING

1. Renew all sealing rings, and smear them with glycerine before assembly. Treat all fibre thrust washers, lubricating wicks and bearing bushes with SAE 5W/20 engine oil. When assembling the housings, align the location marks made before dismantling.
2. Bolt the shift lever housing to the field ring, and assemble the lever arm, linkage and pinion assembly into it, lubricating the linkage with light graphite grease. Insert the armature, together with its washers, and fit the nose housing and steel thrust washer.
3. Assemble the commutator end cover and fit the brushes. Check the brush spring loadings; limits are 13.9 to 16.4 N (50 to 59 oz.f.). Fit the brush cover, with a smear of glycerine on its gasket, and position the joint over a rib of the field ring.

4. Insert the shift lever screwed link into the solenoid switch and using Tool CET 55/105 on the solenoid shaft nut screw the link fully home, and then unscrew it five turns. Enter the switch into its housing on the starter and fit its securing bolts. Connect a 24 volt supply to terminals 1 and 3, push back the pinion assembly and check the clearance between the pinion front face and its thrust washers, using a 4.76 mm (0.187 inch) gauge. Adjust as necessary by turning the shift lever with Tool CET 55/105; this adjustment should be made with the switch de-energised. Do NOT leave the switch energised for more than 30 seconds.
5. Replace the rubber plug in the solenoid switch, fit both jumper leads and apply a few drops of SAE 5W/20 oil to each of the three lubricating points (fig. 4).
6. Test the solenoid switch for correct operating sequence, as follows: Fit Tool CEG 14/3 to the pinion shaft to retain the drive, connect a 24 volt supply across terminals 1 and 3, and check with an Avometer that no reading is recorded between terminals 2 and 3.

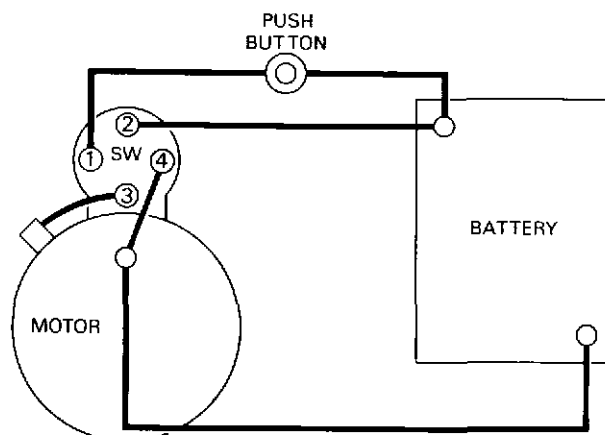

Fig. 3 Butec installation wiring

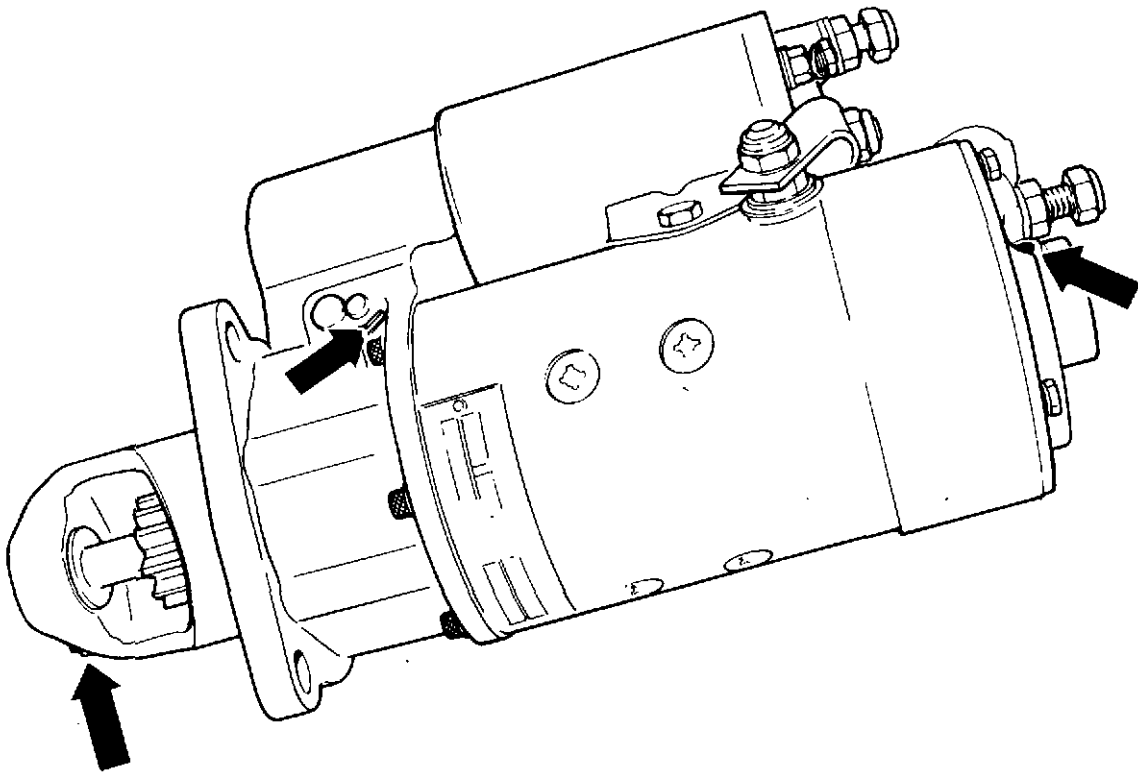

Fig. 4 Butec starter motor — lubrication points

SECTION 15—WHEELCASE, TIMING GEARS AND FAN ADAPTOR

WHEELCASE

Description

A cast aluminium wheelcase, bolted to the front end of the crankcase, houses the main gear train and provides mounting points for the coolant pump, E.S.C., and various other engine components. See the illustration.

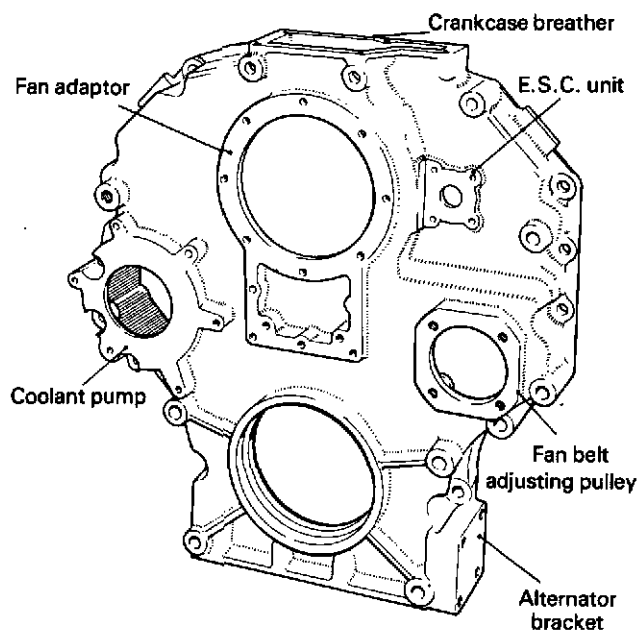

Fig. 1a Wheelcase CV 8095.

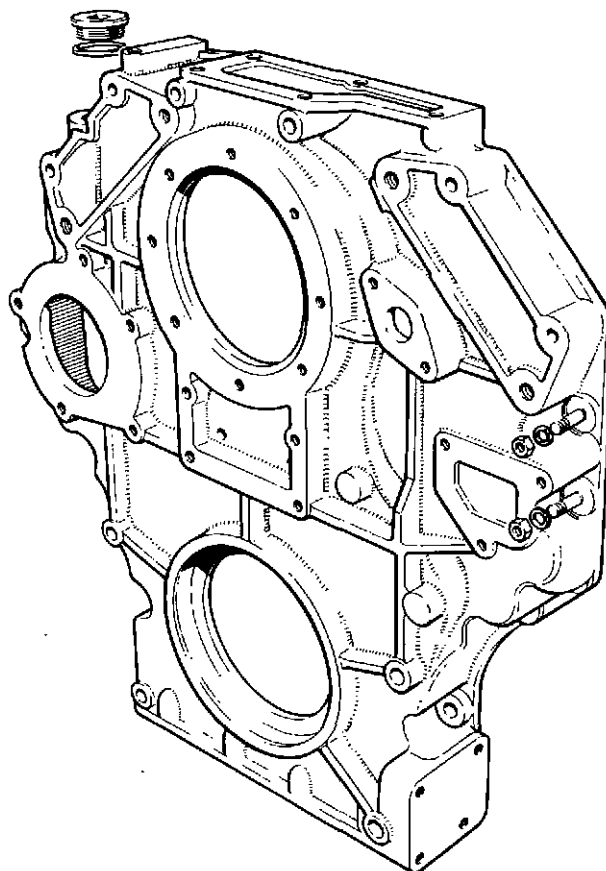

Fig. 1b Wheelcase CV 2680.

Dependent upon application, the engine may be fitted with either of the two wheelcases shown, but all instructions apply to both types.

Removal

Before wheelcase removal, the radiator, fan, alternator, etc., must first be removed as for the camshaft removal. See Section 5.

Remove a securing bolt from each side of the wheelcase and fit Guide Studs, VT 17845, hand tight, into each bolt hole. Remove the remainder of the securing bolts and slide the wheelcase free. Remove the guide studs.

Cleaning and inspection

Tap out the front end oil seal from the crankshaft bore and clean the casting in a non-caustic degreasing solution. Check all the joint faces and oil seal bore for damage.

TIMING GEARS

Description

The main gear train consists of the crankshaft drive gear, oil pump idler, main compounded idler, auxiliary drive compounded gear and two camshaft

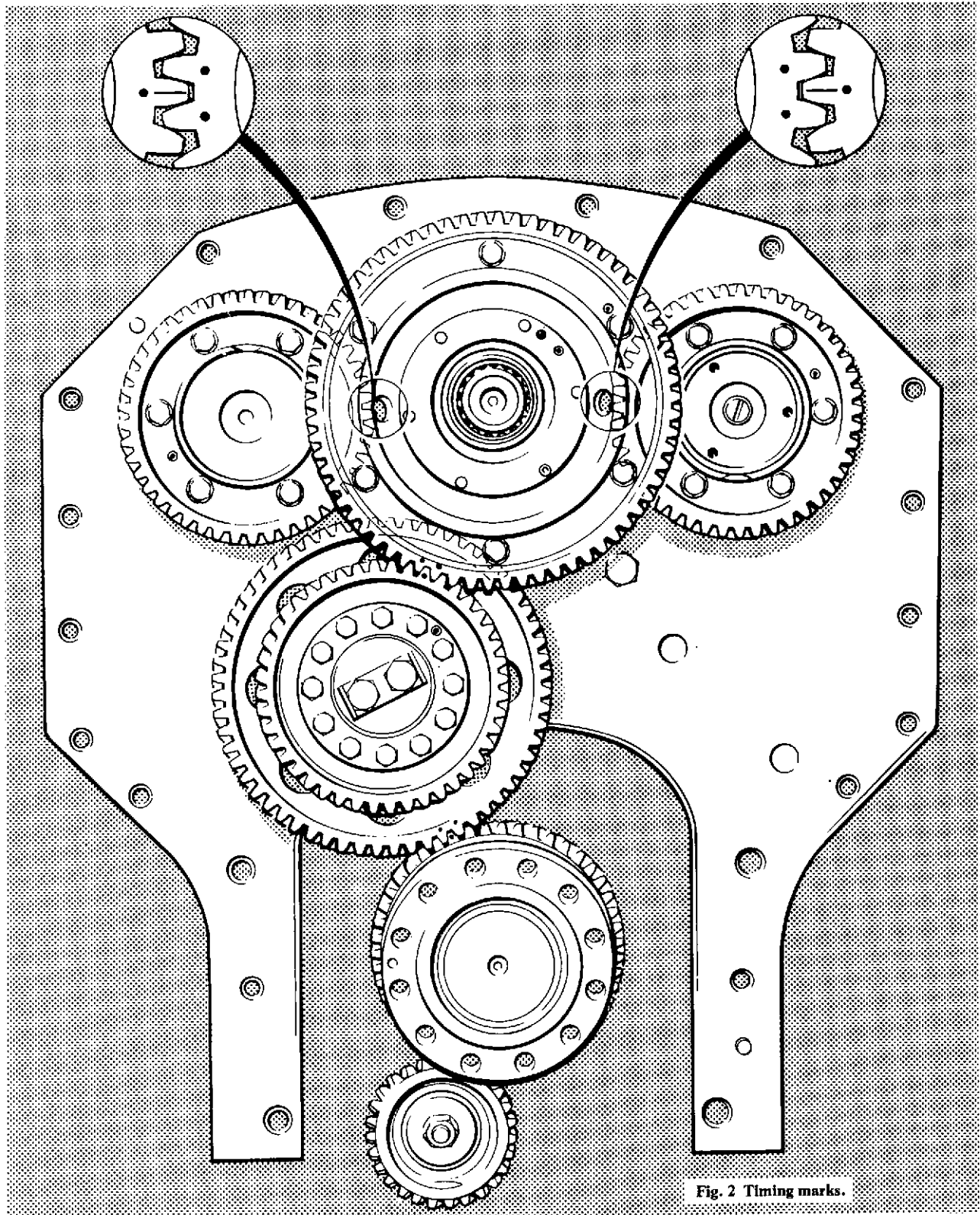

Fig. 2 Timing marks.

drive gears. The coolant pump and lubricating oil pump each have their drive gear built into the assembly.

The oil pump idler axle is secured to the front main bearing housing with a single bolt and self locking nut. The main compounded idler axle, with two thrust washers and the thrust plate, is secured by two bolts and a locking plate.

Timing marks on the crankshaft gear, main idler, auxiliary drive gear and cam drive gears are provided, to ensure correct valve timing during engine operation.

Removal

1. Unscrew the axle securing bolts and remove the compounded and oil pump idler gears and their associated axle assemblies.
2. Remove the 12 setbolts and washers from the main idler assembly and separate the two gears. Withdraw the locating dowel.
3. Disconnect the auxiliary drive coupling, remove the drive flange and lift out the woodruff key. Remove the six nuts and washers from the oil seal housing and withdraw the housing and the

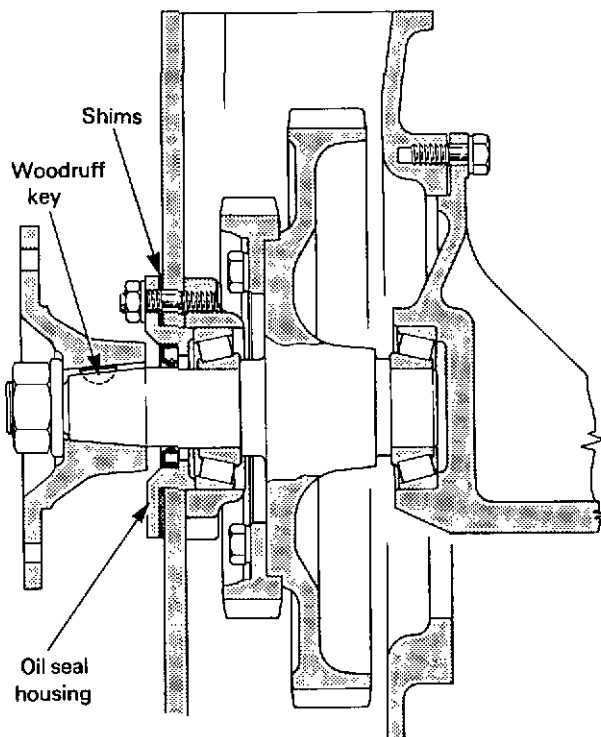

Fig. 3 Auxiliary drive assembly.

auxiliary drive assembly. Retain the shim pack.

Remove the six setbolts and washers from the auxiliary drive gear and separate the two gears. Withdraw the locating dowel.

4. Remove the six setbolts and washers from each of the camshaft drive gears and withdraw the gears. Withdraw the two locating dowels.

Cleaning and inspection

Wash all the gears in paraffin, remove any traces of thread sealing compound and examine the teeth for wear. Wear on the tooth profile is acceptable provided that the backlash is within the permissible limits and there are no signs of pitting. Crack test all the gears, using the electro-magnetic method if available.

Check the idler gear bushes and axles for wear. Insertion and extraction tools are available for bush renewal, see end of Section. Replacement bushes are pre-finished and require no further treatment after fitting.

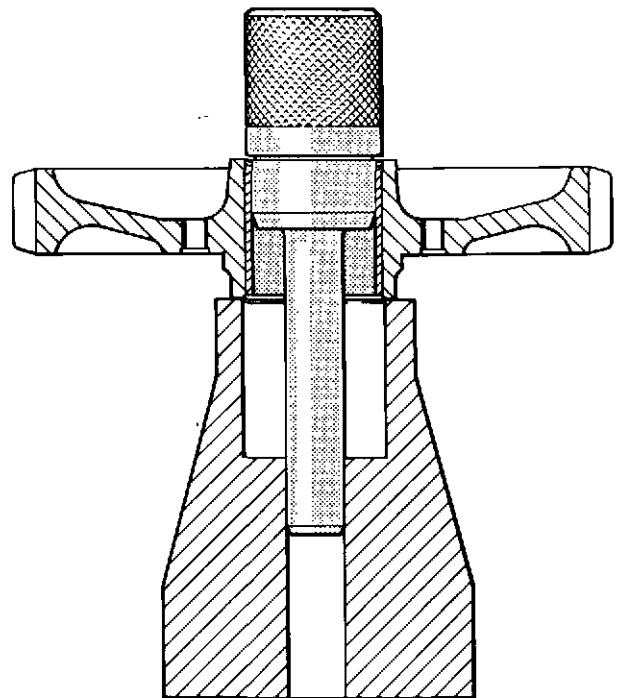

Fig.4 Extracting main idler bush.

Check the end float and inspect the thrust faces of the oil pump idler and the axle flange; renew items which show excessive wear or scoring.

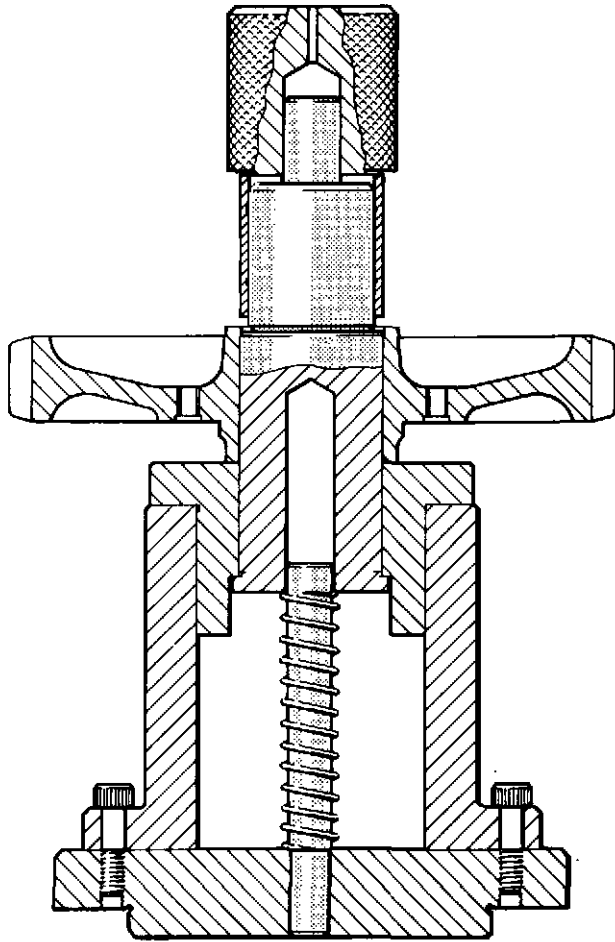

Fig. 5 Inserting main idler bush.

Check the main idler end float and inspect the thrust washers. Thrust washers must be renewed if the oil grooves begin to disappear in the thrust faces. Normal depth of the oil grooves is between 0.18 and 0.38 mm (0.007 and 0.015 inch).

Assembling compound gears

Ensure that the gears are clean and dry, then assemble the two auxiliary drive gears and tap in the locating dowel. The timing marks on the small gear must be visible through the sight holes, in the large gear. Coat the threads of the setbolts with 'Studlock' 270 and insert the setbolts into the bolt holes complete with plain washers. Tighten each setbolt to a torque loading of 30 Nm (22 lbf. ft.).

Fit the small idler to the large idler and tap in the locating dowel. The timing marks on both gears

should be on the same side of the assembly. Coat the threads of the securing setbolts with 'Studlock' 270 and insert the bolts, complete with plain washers through the small gear bolt holes. Tighten the setbolts to a torque loading of 40 Nm (30 lbf. ft.).

Fitting the gear train

Position the camshaft drive gears on the camshaft flanges. Tap in the locating dowels, coat the setbolt threads with 'Studlock' 270 and screw in the setbolts, complete with plain washers. Tighten the setbolts to a torque loading of 40 Nm (30 lbf. ft.).

Fit the main idler assembly to the crankcase as shown in figure 2, ensuring that the timing marks on the large gear are correctly positioned relative to the timing mark on the crankshaft driving gear. Tighten the two securing setbolts to a torque loading of 71 Nm (52 lbf. ft.). Tab up the locking plate.

Check that the camshaft gear timing marks face in towards the centre line of the engine and fit the auxiliary drive assembly to the wheelcase backplate, ensuring that the timing marks are correctly positioned relative to the main idler and camshaft gears.

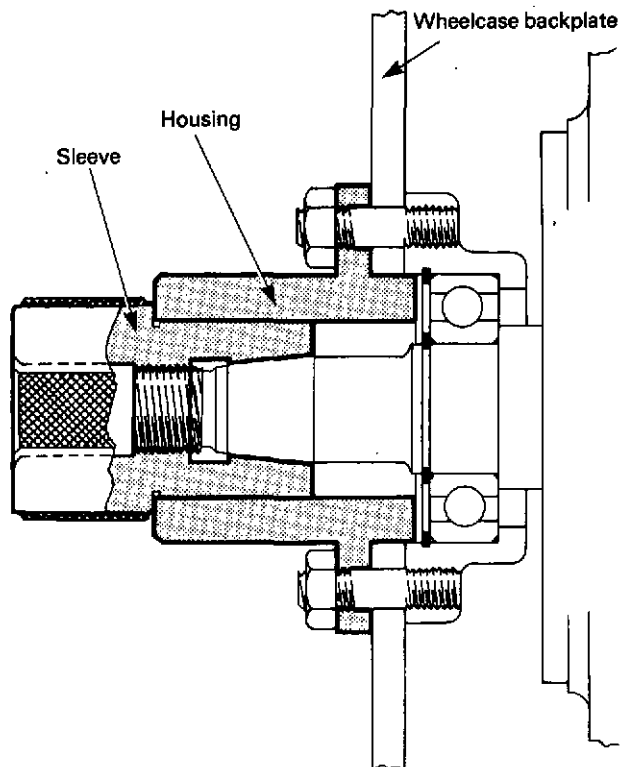

Fig. 6 Alignment tool.

Secure the assembly in position using the Alignment Tool, VT 17974.

Fit the oil pump idler assembly to the front main bearing cap and, using a new self-locking nut, tighten the securing bolt and nut to 80 Nm (60 lbf.ft.).

Check the backlash of all the gears, renew any gear having excessive wear on the tooth profile and renewing any idler bushes which are worn sufficient to cause the idler backlash to exceed the permissible limits.

Fitting the wheelcase

Press a new front end oil seal into the crankshaft bore with the lip facing inwards, (see illustration), using the Insertion Tool, VT 17032.

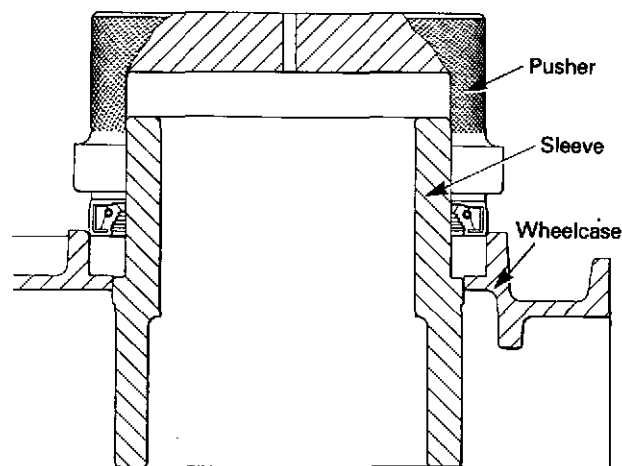

Fig. 7 Inserting wheelcase oil seal.

Check the backplate joint face for cleanliness, apply a thin coating of Wellseal jointing compound and position a new gasket on the backplate. Apply a further coating to the outer face of the gasket, to ensure that the two locating dowels are fitted to the crankcase/backplate assembly, then screw in the two guide studs hand tight, into suitable bolt holes in the assembly.

Lift the wheelcase on to the guide studs and carefully slide it up to the gasket, taking care not to damage the crankshaft oil seal.

Fit the wheelcase bolts and nuts, with spring and plain washers, and tighten to a torque loading of 95 Nm (70 lbf. ft.).

Refit all components previously removed. For necessary details see the relevant Sections in the Manual.

FAN ADAPTOR

Description

The fan adaptor consists of a steel shaft, supported by one roller bearing and one ball bearing, in an aluminium alloy housing.

A lip type oil seal is fitted around the shaft collar and the fan belt pulley is secured to the shaft flange with six setbolts and spring washers. Shims between the pulley and flange provide adjustment for fan belt alignment.

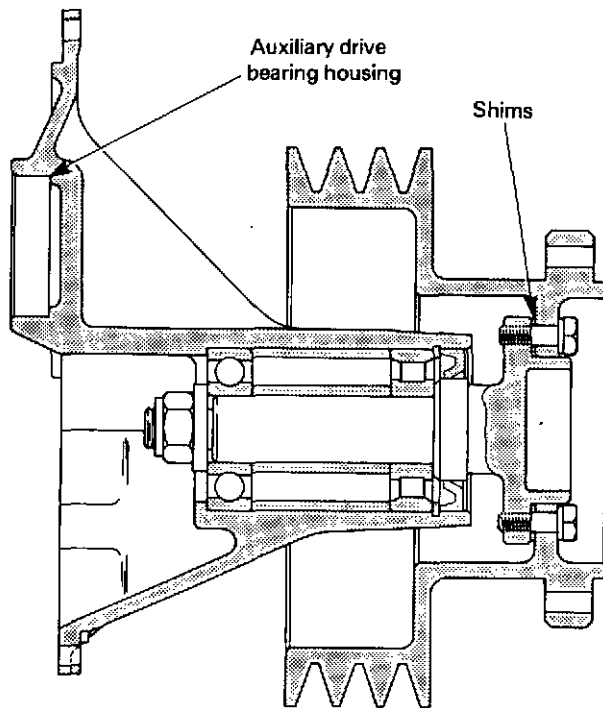

Fig. 8 Fan adaptor.

The two bearings, complete with inner and outer spacers, are secured to the shaft with a single nut and washer. Axial movement of the shaft assembly is controlled by a standard circlip fitted in a groove in the housing between the oil seal and roller bearing.

The housing incorporates the location for the outer race of the auxiliary drive tapered roller bearing.

Dismantling

Release the six pulley securing setbolts and washers and lift off the pulley and associated shims. Retain the shims for re-use.

Using the Holding Device, VT 17033, remove the securing nut and washer. Tap out the shaft, using a soft metal drift. Retain the inner distance piece and, using the appropriate type puller, remove the inner race of the roller bearing from the shaft. Tap out the oil seal and, with the housing on a suitable support, drive out the ball bearing complete with the outer spacer and outer roller race.

Cleaning and inspection

Thoroughly clean the components and check the bearings for wear. If either bearing sounds rough or there is an indication of excessive slackness between the inner and outer races, it is advisable to renew the bearings.

Assembling

Using the Insertion Tool, VT 17037, press the ball bearing into the housing and position the outer

distance piece in the housing.

Using the Insertion Tool VT 18215, fit the outer race of the roller bearing and insert the circlip into its groove.

Position the inner distance piece centrally over the inner race of the ball bearing and locate the inner race of the roller bearing.

Using the Insertion Tool, VT 18214, press in a new oil seal.

Mount the assembly on a suitable stand and, using the Insertion Tool, VT 17036, press the shaft fully home.

Fit the nut and washer to the end of the shaft and tighten to a torque loading of 135 Nm (100 lbf. ft.).

Using a new gasket, lightly coated with Wellseal jointing compound, fit the adaptor assembly to the wheelcase and secure with setbolts and spring washers.

Refit the shims and fan belt pulley to the shaft flange and nip up the six securing setbolts and spring washers. Check the belt alignment and adjust the shim pack accordingly before finally tightening the setbolts securely.

SPECIAL TOOLS

Part No.	Description
Wheelcase	
VT 17845	Guide studs, wheelcase fitting/removal.
VT 17032	Insertion tool, oil seal.
Timing gears	
VT 12036	Insertion tool, main idler bush.
VT 12037	Insertion tool, oil pump idler bush.
VT 12818	Extraction tool, main idler bush.
VT 12819	Extraction tool, oil pump idler bush.
VT 17974	Alignment tool, auxiliary drive.
Fan adaptor	
VT 17033	Holding device, adaptor shaft.
VT 17037	Insertion tool, ball bearing.
VT 18215	Insertion tool, roller bearing.
VT 18214	Insertion tool, oil seal.
VT 17036	Insertion tool, shaft.

FITS AND CLEARANCES
WHEELCASE, TIMING GEARS AND FAN ADAPTOR

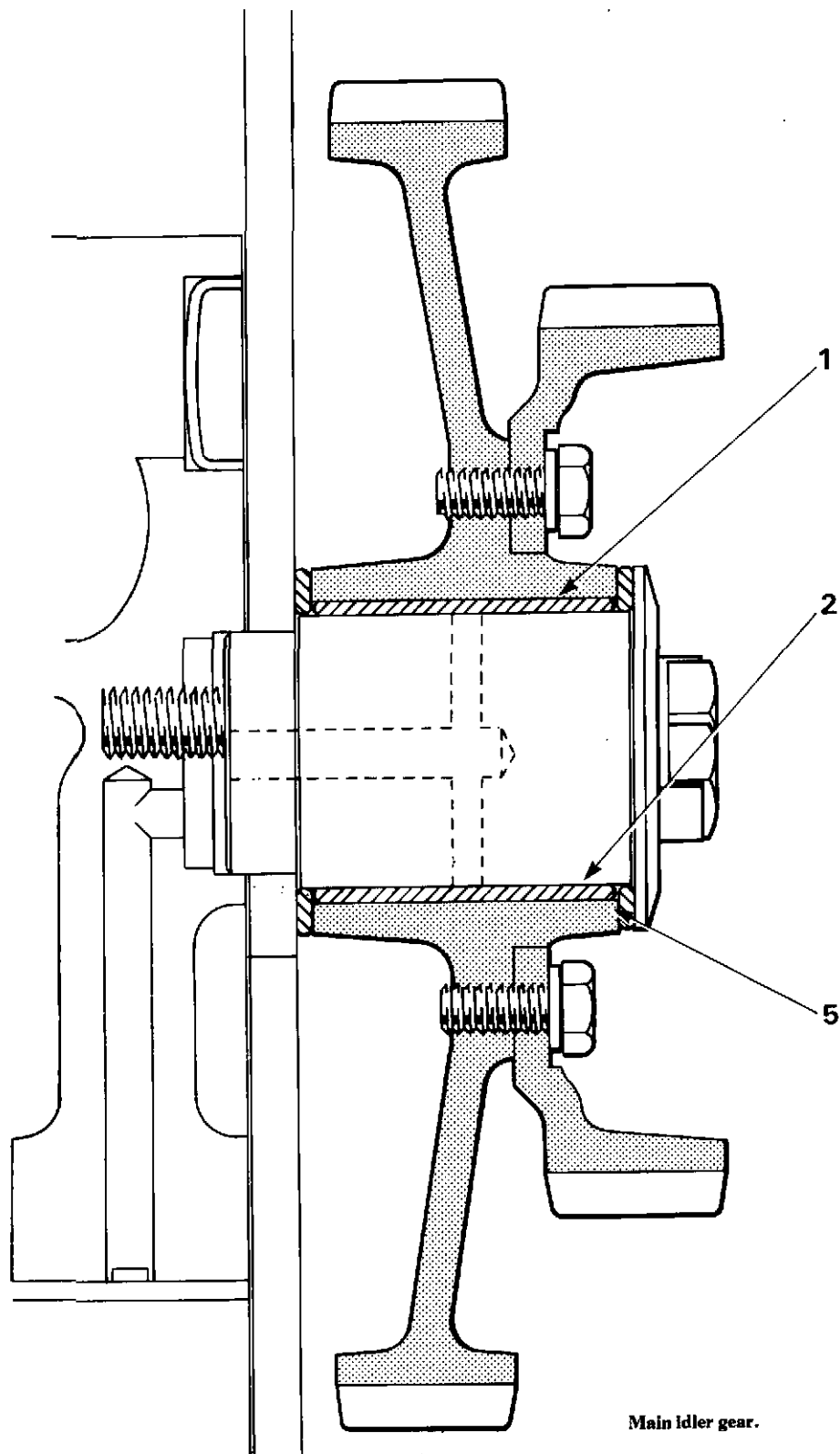

ROLLS-ROYCE DIESELS

No. ON DIAG.	DESCRIPTION	DIMENSIONS NEW		PERMISSIBLE WORN DIMENSIONS		CLEARANCE NEW		PERMISSIBLE WORN CLEARANCE		REMARKS
		mm	inch	mm	inch	mm	inch	mm	inch	
1	BACKLASH BETWEEN GEARS Aux. drive—camshafts Aux. drive—main idler Coolant pump—main idler Main idler—crankshaft Oil pump idler—crankshaft Oil pump idler—oil pump									Imperial dimensions have been 'rounded up' to nearest 1/1000 inch for convenience.
						0.10 to 0.233	0.004 to 0.009			
						0.10 to 0.252	0.004 to 0.010			
						0.10 to 0.277	0.004 to 0.011			
						0.10 to 0.239	0.004 to 0.009			
						0.10 to 0.235	0.004 to 0.009			
						0.10 to 0.380	0.004 to 0.015			
2	IDLER GEARS ON AXLES Main idler Gear bore Bush diameter Bush bore Axle diameter									

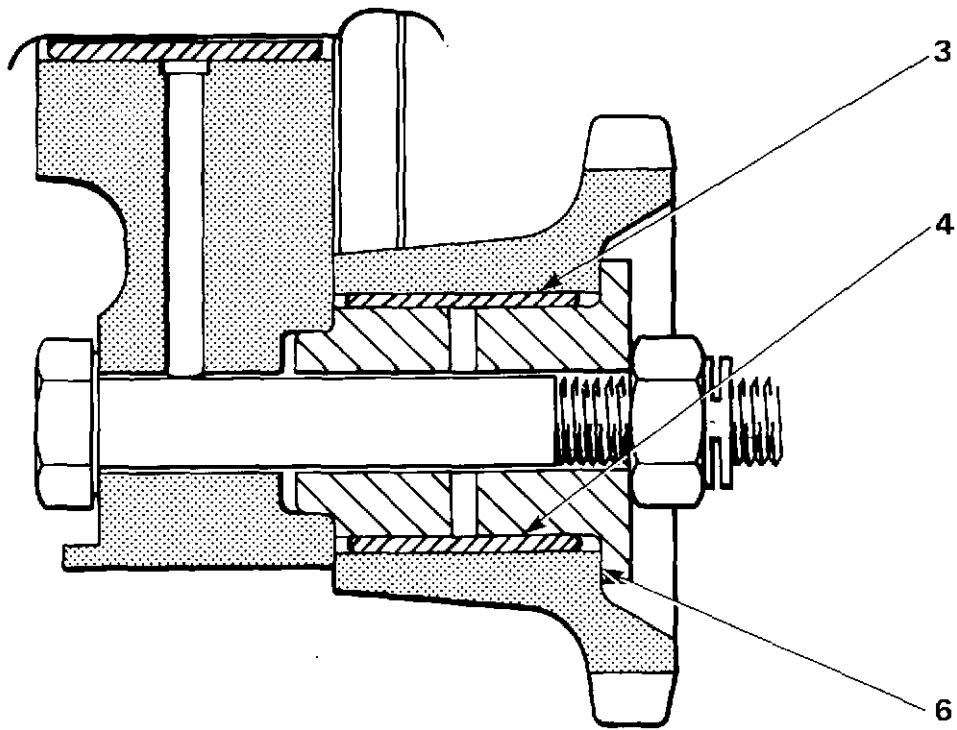

Oil pump idler.

ROLLS-ROYCE DIESELS

No. ON DIAG.	DESCRIPTION	DIMENSIONS NEW		PERMISSIBLE WORN DIMENSIONS		CLEARANCE NEW		PERMISSIBLE WORN CLEARANCE		REMARKS
		mm	inch	mm	inch	mm	inch	mm	inch	
3	Oil pump idler									
	Gear bore	34.0 to 34.025	1.338 to 1.339							
	Bush diameter	34.087 to 34.125	1.342 to 1.343			Interference 0.062 to 0.125	0.024 to 0.0049			
	Bush bore	29.997 to 30.023	1.1809 to 1.1820							
4	Axle diameter	29.947 to 29.960	1.179 to 1.1795			0.037 to 0.076	0.001 to 0.003	0.151	0.0059	
	IDLER GEAR END FLOAT Main idler axle Shaft length	56.15 to 56.20	2.2106 to 2.2126							
5	Gear hub width	50.875 to 51.0	2.0029 to 2.0079			*0.10 to 0.425	*0.004 to 0.017	See 'REMARKS' column		Check thrust washer oil grooves and renew the washers before the grooves blend into the thrust faces—Nominal depth of oil grooves 0.18 to 0.38 mm (0.007 to 0.015 inch). *These dimensions take into account possible slight 'bowing' of the thrust washers.
	Thrust washer thickness	2.4 to 2.45	0.0949 to 0.0965							
6	Oil pump idler axle Shaft length	35.20 to 35.30	1.385 to 1.389			0.15 to 0.30	0.006 to 0.012			
	Gear hub width	35.00 to 35.05	1.377 to 1.379							

SECTION 16—RUNNING-IN AND TESTING

Every new or reconditioned engine supplied by Rolls-Royce is run and tested before being despatched from the factory. It requires no special treatment when put into service but the Operator is recommended to follow the instructions given in the Servicing Manual, T.S.D. 3115, Chapter 2.

When a CV8 engine in service has been completely overhauled or built up from a 'short engine', or when a partial overhaul has involved renewal of cylinder liners, piston rings and bearings, a running-in schedule applicable to the engine rating should be carried out, as described in the following text.

Note: Prior to running-in an engine, refer to Section 13 of this Manual for details concerning precautions adopted by Rolls-Royce Motors Limited to protect the turbocharger bearings from possible contamination during running-in at the factory.

Period	R.p.m.	Load or rated power	Duration (minutes)
1	1500/1800	*MBL	5
2	1500/1800	25%	5
3	1500/1800	50%	10
4	1500/1800	75%	10
5	1500/1800	100%	10

*Minimum brake load.

At the start of period 5, load and speed must be checked to prevent possible overload.

During the running-in period the cause of any obvious noise or vibration should be sought, and the engine checked for leaks, which should be rectified after the run-in period is completed.

Engine shutdown must only take place at the end of a period, or in the case of an emergency.

RUNNING-IN

1. Prepare the engine for running and start up as described in the Servicing Manual T.S.D. 3115, Chapter 2.
2. Start the engine, run it at approximately 800 r.p.m. (automotive) or off load (industrial) and check that the correct oil pressure is registered steadily on the gauge. Inspect all the systems for leaks and shut down the engine. Rectify any leaks and top up the coolant and engine oil to the correct levels.
3. At the satisfactory conclusion of the running-in schedule, it is advisable to carry out an oil consumption check in the manner described.

Running-in schedule

Start the engine and proceed with the following schedule:

CV8 engines rated at 1500 r.p.m. or 1800 r.p.m.

OIL CONSUMPTION CHECK

Where practicable it is advisable to carry out the following check which is suitable for both the 1500 and 1800 r.p.m. rated engines.

Check schedule

1. Ensure that the engine oil level is *exactly* to the **MAXIMUM** mark indicated on the dipstick.
2. Run the engine at rated speed and power until the oil and coolant reach the normal working temperatures:
Coolant outlet : 68 to 85 deg. C.
Oil reservoir : 90 to 105 deg. C.
3. Allow the engine to run at idling speed, minimum brake load for two minutes, and then shut down. Wait for two minutes and then ensure that the oil level is to the **MAXIMUM** mark on the dipstick. Replenish if necessary to reach this level but **DO NOT OVERFILL**.

Note: The engine must not be rotated after this operation and should carry a prominent notice to this effect.

13. Spray the valve gear with PX4 inhibitor, then refit the rocker covers.
14. Drain the PX4 inhibitor from the engine sump and oil filter canisters. Attach a 'NO OIL' notice to the filler cap.
15. Drain the cooling system and refill with a fresh coolant mixture of inhibited ethylene glycol and clean water.
Note: The mixture must not contain less than 50% inhibited ethylene glycol and may contain up to 90% by volume.
 Allow the system to settle for 15 minutes, then completely drain off the coolant mixture. Attach a 'NO COOLANT' notice to the coolant filler cap.
16. Disconnect the exhaust system at the turbo-charger diffuser outlet or, on normally aspirated engines, at the junction of the manifolds. Inject two grammes of VPI 260 powder, (see end of Section), and fit a blanking plate. Do NOT reconnect the exhaust pipe.
17. Disconnect the air cleaner(s) and inject two grammes of VPI 260 powder into Cyclopac type air cleaners. Oil-bath, wire mesh or dry nylon type air cleaners may be sprayed internally with PX4 inhibitor or VPI 260 powder.
18. Inject two grammes of VPI 260 powder into the turbocharger. Re-connect the air cleaner(s).
19. Brush coat or spray all unpainted areas of the engine and auxiliary equipment with 'Crodafluid' PM 47, (see end of Section), paying special attention to the fuel control linkage.
Caution: Do NOT spray PM 47 into the vent apertures of the alternator.
20. Wrap the alternator and starter motor in mouldable wax wrapping and seal with adhesive tape.

21. Seal the air cleaner inlet, crankcase breather and any other openings with mouldable wax wrapping and adhesive tape or plastic caps as appropriate.
22. Remove all driving belts, dust them liberally with french chalk and place them in a sealed polythene bag attached to the engine.
23. Finally, affix a label in a prominent position on the engine stating:
 - (a) That the exhaust system has been blanked off.
 - (b) The date on which the engine was inhibited and the date on which the engine will require re-inhibiting.

If the engine is to remain in storage for more than one year, the above procedure must be carried out at the end of each 12 month period.

REMOVAL FROM STORAGE

Instructions for preparing the engine for running after storage can be found in CHAPTER 2—OPERATING, in the SERVICING MANUAL, TSD 3115. The information given applies equally to newly installed engines and those removed from storage.

APPROVED PRODUCTS FOR ENGINE INHIBITING

Cooling and sea-water systems.

Inhibited ethylene glycol as listed in leaflet T.S.D. 3085.

Thermostats

Ambersil Ltd MS 4

Lubrication system

Croda Chemicals Ltd PX4

Induction and exhaust systems

Shell Chemicals Ltd VPI 260 powder

Fuel system

Croda Chemicals Ltd PX4

External protective oils

Croda Chemicals Ltd 'Crodafluid' PM 47

ROLLS-ROYCE MOTORS LIMITED

DIESEL DIVISION

SHREWSBURY, SHROPSHIRE SY1 4DP, ENGLAND

Telephone: STD Code 0743/52262. Telex: 35171-2

Telegrams: 'ROYCAR', Shrewsbury

©Rolls-Royce Motors Limited 1982

Subject to any existing rights of third parties, the information contained in this document is the property of Rolls-Royce Motors Limited and should not be copied (in whole or in part) or used for manufacture or otherwise disclosed without the prior written consent of the Company. (This does not preclude use by engine and equipment operators for normal instructional, maintenance or overhaul purposes).

TSD 3130/CV8 782 2M

ISSUED BY ROLLS-ROYCE MOTORS LIMITED