

Function – Installation

Electronic Speed Governor

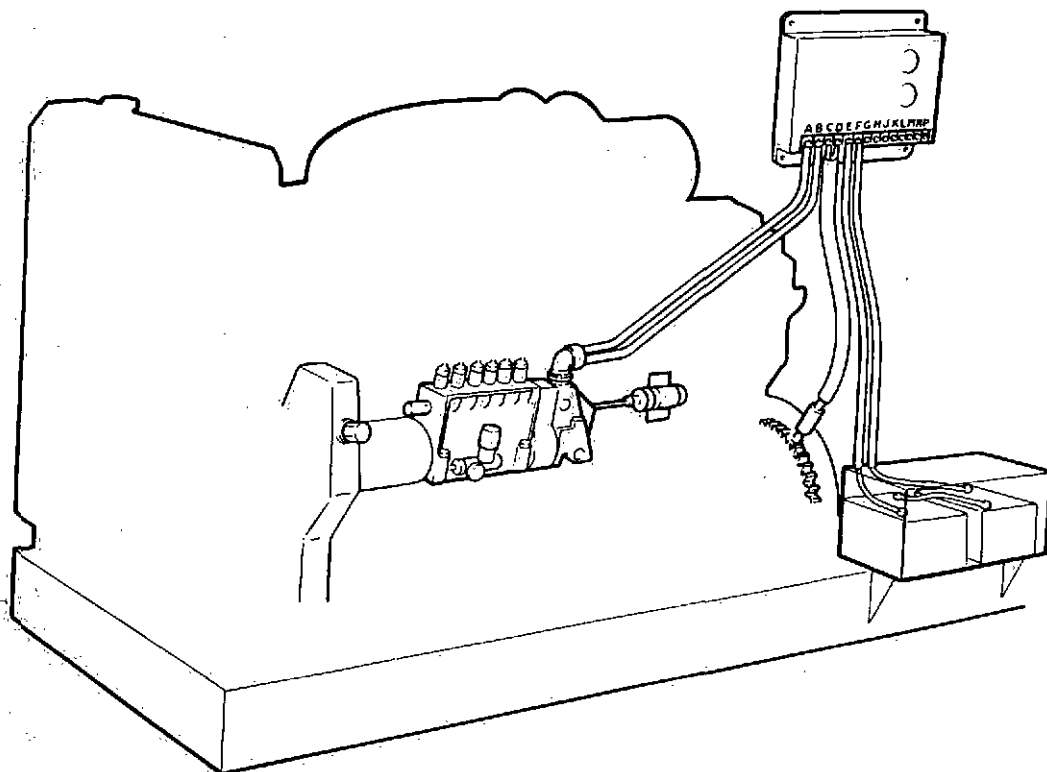

Important

This manual is designed to provide helpful information for use in installing Volvo Penta products.

It is **not** a comprehensive manual. It is **not** designed to cover every possible application or installation of Volvo Penta products. It is the responsibility of the installer to select the appropriate Volvo Penta products and associated hardware for particular uses.

It is the sole responsibility of the installer to make sure that the installation and application of the Volvo Penta products are in compliance with APPLICABLE STATE, FEDERAL, AND LOCAL REQUIREMENTS.

**AB VOLVO PENTA
Technical Information**

Electronic Speed Governor

Function – Installation – Fault-tracing

This booklet only covers the ACB225 and ACB275 actuators and the ESD5500 control unit.

Contents

General description	2
Function	3
Installation	6
Electromagnetic compability	7
Setting and Adjusting	8
Running	10
Fault-tracing	12

General description

The electronic governor system is a control unit which governs the engine speed. Its task is to:

- maintain the idling speed at the set value
- maintain the engine's operating speed at the pre-set value despite varying loads.

Unlike the mechanical governor, the electronic governor does not have governor weights. The speed is controlled by the control unit (1, fig 1) "sensing" the difference between the set speed and the actual speed.

The difference value is converted into a signal to an electro-magnet (actuator) which adjusts the injection pump's fuel rack to increase or decrease the injected fuel amount.

The following text describes the components making up the system, and their function, separately.

Certain engines have injection pumps with RQ governors fitted as speed limiters. In these cases the actuator is fitted on a separate bracket. The sender and the electronic overspeed protection is omitted in these cases, and the stop solenoid/fuel shut off valve is only used to stop the engine normally.

WARNING!

An overspeed protection **MUST** always be fitted besides the electronic governor to prevent bodily injury or material damage if the engine should run out of control.

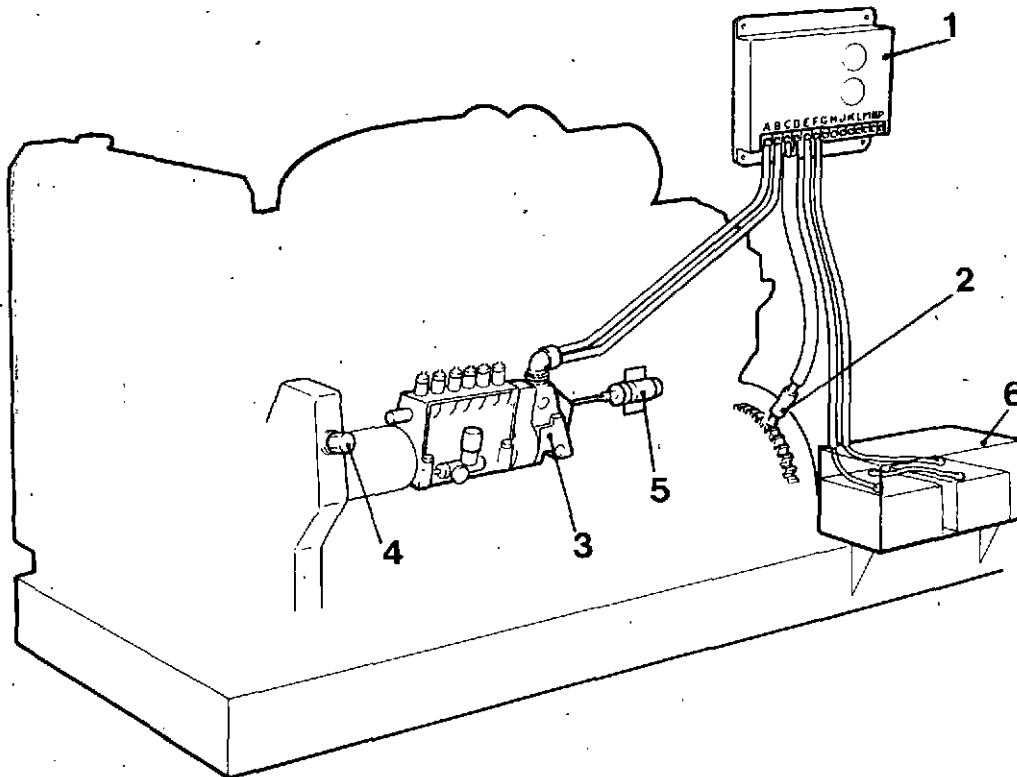

Fig. 1. Engine fitted with an electronic governor (system diagram)

- | | |
|------------------------|---|
| 1. Control unit | 4. Engine speed pickup for overspeed protection |
| 2. Engine speed pickup | 5. Stop solenoid / Fuel shut off valve |
| 3. Actuator | 6. Batteries |

Function

Engine speed pickup

The engine speed pickup is an electromagnet fitted in the flywheel housing directly above the flywheel ring gear. As the teeth of the ring gear pass under the electromagnet an **alternating current** is induced (one cycle per tooth).

The pulse's voltage is between 1V AC to 30V (AC. RMS.)

The pickup's threads is 5/8"-18 UNF-2A.

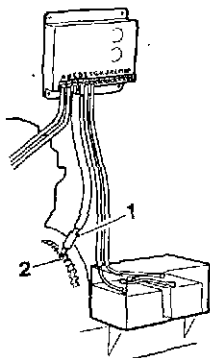

Fig. 2. Location of engine speed pickup

1. Engine speed pickup
2. Flywheel ring gear

Control unit

The electronic control Unit (fig 3) compares the incoming signals with the pre-set values, and a correcting signal or an unchanged signal is transmitted to the actuator.

The control unit has a number of adjustment possibilities which are described below. Adjustments can be made after first removing the round rubber plugs from the Control Unit.

1. **Adjusting the idling speed** (marked "IDLE"), (4, fig. 3) is done with a single turn potentiometer. The idling speed can be adjusted with a jumper between the terminals "G" and "M" installed.

The adjustment range is 1200-4100 Hz below the frequency for the set engine speed. Turning the potentiometer **clockwise will increase** the idling speed.

2. **Adjusting the operating speed** ("SPEED"), (1, fig. 3) is done with a 22 turn potentiometer.

The frequency range is 100-6000 Hz. Turning the potentiometer **clockwise will increase** the engine speed.

The frequency from the magnetic pickup (engine speed pickup) is dependent on the number of teeth on the flywheel ring gear and the desired engine speed, i.e. the engine speed in r/s (revs per second) multiplied by the number of teeth on the ring gear.

Engine	No. of teeth
6/7 Ltr. engines	140
10/12 Ltr. engines	156
16 Ltr. engines	153

Exemple: Engine TWD1630 set on 1500 r/min. (25 r/s):

$$25 \times 153 = 3825 \text{ Hz.}$$

3. **Governor sensitivity.** The governor's sensitivity is adjusted by a single turn potentiometer ("GAIN"), (2, fig 3). A small change of frequency can be noticed when adjusting the sensitivity. This can be adjusted by the "SPEED" potentiometer (1).
4. **Stability control.** The governor's time constant is adjusted by the single turn potentiometer ("STABILITY"), (3, fig 3).

The time constant is the time required by the engine to return to the set operating speed after there has been a change in load.

5. **Droop.** The droop control (5, fig 3), marked "DROOP" is working when terminals "K" and "L" are connected. The adjustment range is 1-5%. Turning **clockwise will increase** the value.

With a jumper between terminals "G" and "H", an increased droop can be obtained.

6. **Starting fuel adjustment.** Turning the "STARTING FUEL" adjustment **clockwise will increase** the amount of fuel delivered to the engine during cranking. With the adjustment **full counter-clockwise**, the fuel amount will be very low or zero depending on the actuator linkage. With the adjustment **full clockwise**, starting fuel is unlimited and the actuator will move to 100% fuel during cranking.

7. **Speed Ramping Adjustment.** Turning the "SPEED RAMPING" adjustment **clockwise will slow** the acceleration of the engine speed. With the adjustment **full clockwise**, the acceleration can be as long as 20 seconds depending on the speed range selected. With the adjustment **full counter-clockwise**, the ramping will be effectively eliminated.

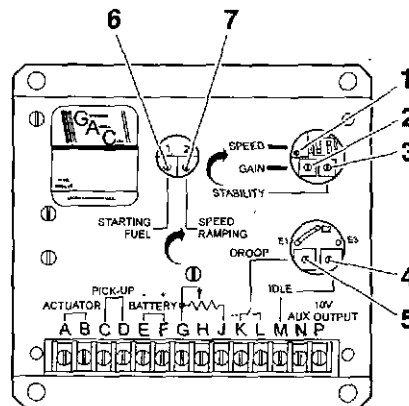

Fig. 3. Control unit ESD5500 with the rubber plugs removed.

1. Operating speed, setting
2. Sensitivity, setting
3. Stability control
4. Idle adjustment
5. Droop control
6. Starting fuel adjustment
7. Speed ramping adjustment

Speed Control Unit ESD 5500

Introduction

The ESD 5500 Series speed control unit includes all of the features of the ESD 5131. In addition, it includes a feature that controls the fuel delivered to the engine during the starting process. By eliminating excess fuel, less smoke is produced resulting in environmental benefits. Replacement of older speed controls on existing engines is a simple and environmentally responsible process.

The only difference between the installation of an ESD 5500 and that of the ESD 5100 Series is the Idle selector switch connections. The ESD 5500 uses Terminals "M" and "G" while the ESD 5100 used Terminals "M" and "L".

Adjustment description

The performance adjustments of the ESD 5500 are set exactly like those of the ESD 5100 Series. The STARTING FUEL and SPEED RAMPING adjustments control the start up characteristics of the engine. With proper adjustment, a smooth start, with minimum excess fuel, can greatly reduce excessive smoke during engine starting.

Starting fuel adjustment

Turning the STARTING FUEL adjustment **clockwise** will increase the amount of fuel delivered to the engine during cranking. With the adjustment **full counter-clockwise**, the fuel amount will be very low or zero depending on the actuator linkage. With the adjustment **full clockwise**, starting fuel is unlimited and the actuator will move to 100% fuel during cranking.

Speed Ramping Adjustment

Turning the SPEED RAMPING adjustment **clockwise** will slow the acceleration of the engine speed. With the adjustment **full clockwise**, the acceleration can be as long as 20 seconds depending on the speed range selected. With the adjustment **full counter-clockwise**, the ramping will be effectively eliminated.

Adjustments

Preset the ESD 5500 as follows:

- STARTING FUEL Full clockwise (Maximum fuel)
- SPEED RAMPING Full counter-clockwise (Fastest)

1. Start the engine and adjust the Speed, Gain, Stability and Dead Time Compensation as described on page 3. The fuel delivery should not be restricted at this time.
2. Place the engine in idle by connecting Terminals "M" and "G"
3. Adjust the IDLE speed for as low speed setting as the application allows.
4. Adjust the STARTING FUEL **counter-clockwise** until the engine speed begins to fall. Increase the STARTING FUEL slightly so that the idle speed is returned to the desired level.
5. Stop the engine.

One of two methods of operation for the ESD 5500 may now be selected.

Method 1 - Start the engine and accelerate directly to the operating speed (Gen sets, etc.).

OR

Method 2 - Start the engine and control at an idle speed for a period of time prior to accelerating to the operating speed. This method separates the starting process from the acceleration process so that each may be optimized for the lowest smoke emissions.

Method 1

Remove the connection between Terminals "M" and "G". Start the engine and adjust the SPEED RAMPING for the least smoke on acceleration from idle to rated speed. If the starting smoke is excessive, the STARTING FUEL may need to be adjusted **slightly counter-clockwise**. If the starting time is too slow, the STARTING FUEL may need to be adjusted **slightly clockwise**.

Method 2

Replace the connection between Terminals "M" and "G" with a switch, usually an oil pressure switch. Start the engine. If the starting smoke is excessive, the STARTING FUEL may need to be adjusted **slightly counter-clockwise**. If the starting time is too long, the STARTING FUEL may need to be adjusted **slightly clockwise**.

When the switch opens, adjust the SPEED RAMPING for the least amount of smoke when accelerating from idle speed to rated speed.

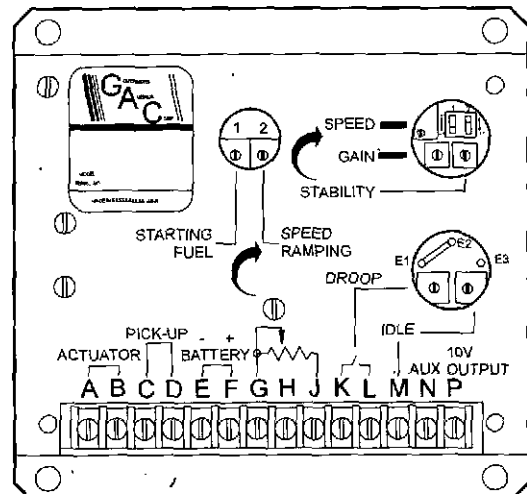

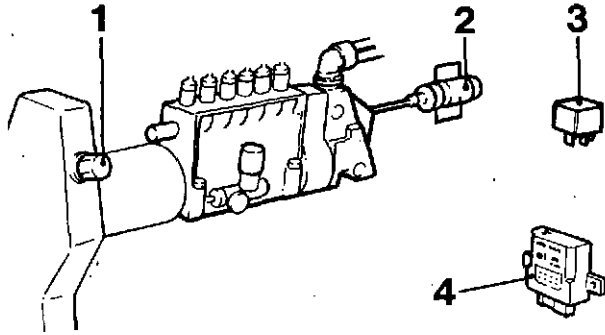

Fig. 4. Engine with electronic overspeed protection

- 1. Engine speed pickup
- 2. Stop solenoid
- 3. Relay for stop solenoid
- 4. Overspeed protection

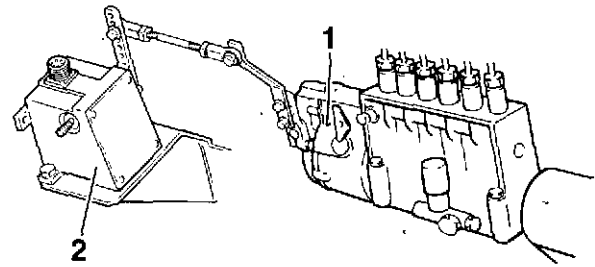

Fig. 6. Engine with mechanical overspeed protection

- 1. RQ governor
- 2. Separately installed actuator

Overspeed protection

As an extra safety protection against overspeed and consequent damage, a separate overspeed protection must be included in the electronic governor system.

The engine speed pickup for the overspeed protection is fitted in the timing gear casing. The overspeed protection should be set so that the operating speed can be exceeded by approx. 15%. The adjustment is done using the trim potentiometer (C/D, fig 5).

At the pre-set shut-down point, the stop solenoid is activated which pulls the injection pump's stop lever to the zero fuel position thus stopping the engine.

If the engine is fitted with a RQ governor, then this will function as an overspeed protection. The RQ governor limits the engine speed mechanically.

An overspeed protection must always be installed for safety reasons.

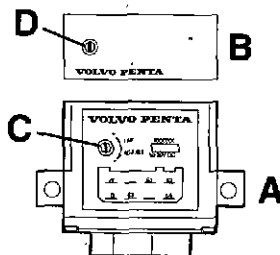

Fig. 5. Electronic overspeed protection

- A. Version 1
- B. Version 2
- C, D. Adjuster screws for setting the shut-down point*

*One turn of the adjuster screw "C" corresponds to approx. 70 r/min for the 16 liter range (or approx. 85 r/min for other engines that have later been equipped with the overspeed protection).

The adjustment sector (270°) for screw "D" corresponds to appr. 1560-2700 r/min.

Actuator

The actuator is an electromagnet. The actuator, type ACB275, is fitted to the rear of the injection pump and replaces the usual mechanical governor.

On certain injection pumps there is an RQ governor fitted as an overspeed protection. For these cases, an actuator type ACB225 is fitted separately.

The control signals, which the control unit transmits to the actuator, are transferred to the injection pump's fuel rack via a linkage system.

The actuator converts the control signals from the control unit to controlling forces.

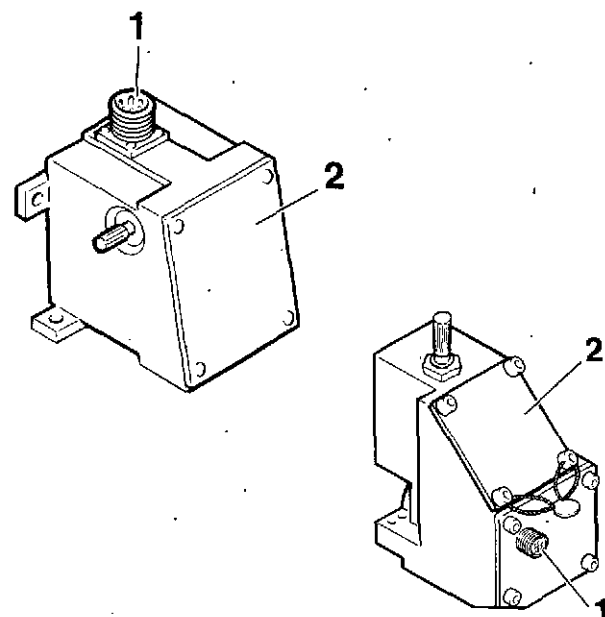

Fig. 7. Actuators, type ACB225 and ACB275

- 1. Connection to the control unit
- 2. Inspection cover

Installation

Power supply

The power supply can be either 12V or 24 V DC. No ground circuit is required as the circuits are isolated from the control unit's casing.

Max. current at 24V is approx. 4A, and at 12V approx. 8A. The control unit should be fused with a 15A for 12V, and 8A for 24V, fast typed fuse:

Note! A battery charger must not be connected so that overvoltage occurs in the system.

Location of the control unit

The control unit should be placed in a protected place which is not subject to extreme vibrations or temperatures. The control unit functions well at temperatures between - 40°C to + 85°C (- 40 to + 185°F).

Wiring

The wiring is shown in the wiring diagram, fig 8.

Note that all components are connected to the control unit (two cables each from the actuator, pickup and battery).

12 V
Jumper A to C
Jumper B to D
A & D connected to the control unit

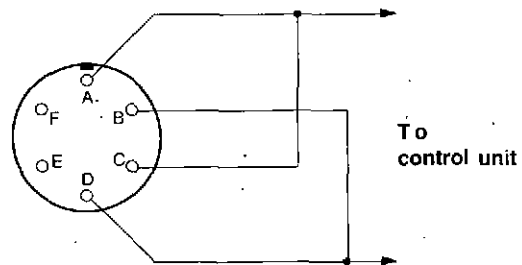

Fig. 9. Connecting the actuator for 12V system voltage

24 V
Jumper B to C
A & D connected to the control unit

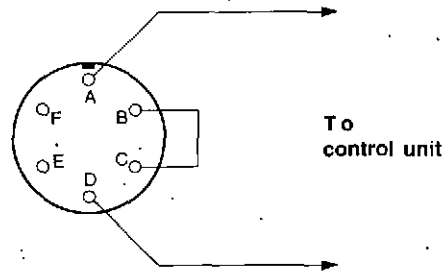

Fig. 10. Connecting the actuator for 24V system voltage

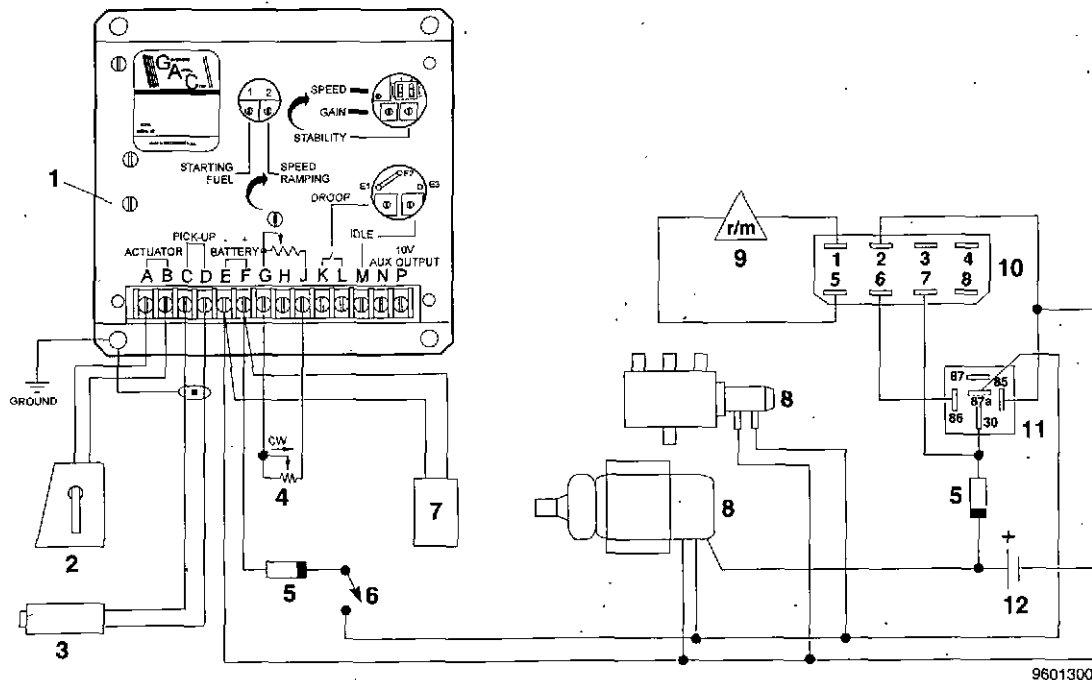

Fig. 8. Connecting the stop solenoid or fuel valve, live during operation, 24V system.

Note. The later version stop solenoid has a built-in transient protection. Therefore, only a separate transient protection (7) for the control unit is required.

- | | | |
|------------------------|---------------------------------------|---|
| 1. Control unit | 5. Fuse (fast) | 9. Engine speed pickup for overspeed protection |
| 2. Actuator | 6. Main switch | 10. Engine speed switch (overspeed protection) |
| 3. Pickup | 7. Transient protection | 11. Relay |
| 4. External speed trim | 8. Stop solenoid/ Fuel shut off valve | 12. Battery: 12V or 24V |

Wiring

The 6 basic wires should have the following min. crosssection in mm²

Terminal	12V		24V	
	up to 6 Meters (19.7 feet)	over 6 Meters (19.7 feet)	up to 6 Meters (19.7 feet)	over 6 Meters (19.7 feet)
A - B to actuator	2,5	4,0	1,5	2,5
E - F to battery	2,5	4,0	1,5	2,5
C - D to speed sensor	Use shielded cable 2 x 0,75 or 2 x 1,0. Shield at pick-up open, at control unit at D. If shielded cable is not available, then twist the two leads all the way.			
Other terminals (if used)	Conduct only milliamps, hence 1,0mm ² is sufficient. In case of strong electro- magnetic fields use only shielded cables. Shield to terminal "G".			

Electromagnetic compability

In order to be in compliance with the EMC directives, the installer is obligated to install the equipment in strict accordance with the following special instructions and guidelines:

1. The speed control unit must be mounted against a metal ground plane with four bolts which make positive electrical connection between the control unit casing and the back plane or a backing plate.
2. The magnetic pickup must be connected to the control unit using shielded cable as shown in the wiring diagram, fig. 11.
3. All shielded cable connections to the control unit must be connected to the casing.
4. The battery minus connection to terminal "E" must also be additionally jumpered to the control unit casing. For isolated ground systems use a 0.01 μF capacitor. The capacitor should be a good quality ceramic type that withstand the required isolation voltage (500V - 1kV).
5. Shielded cable for the actuator is recommended to minimise the actuator's slight movement during fast high voltage transients. The installer's choice of not using shielded cable may cause the actuator to move more than slightly during these transients. However, no failures should be experienced.
6. The installer must refer to the wiring diagram below.

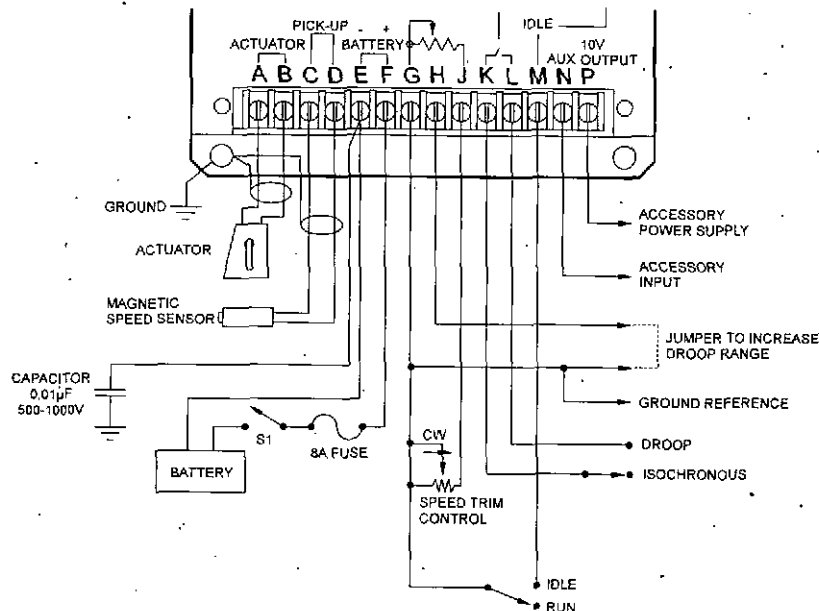

Fig. 11

Setting and Adjusting

Basic setting from Volvo Penta

Engines with electronic speed control delivered from Volvo Penta have their idling speed set at approx. 400 r/min (jumper between "G" and "M" on the control unit).

Engines for 1500 r/min operation have their operating speed set to approx. 1567 r/min (no jumper between "G" and "M"). Droop approx. 4.5% with jumper between "K" and "L".

Engines for 1800 r/min operation have their operating speed set to approx. 1870 r/min and the droop to approx. 4.5 %.

The correct power output is set during the engine's test run on the dynamometer. Thereafter, the governors are sealed by Volvo Penta (ACB 275).

The control unit that is delivered and to be fitted to the engine, is used for the testing and adjusting. The control unit is then marked by Volvo Penta with both the order No and engine No.

Therefore, it is important that control units are not mixed when several engines are delivered at the same time.

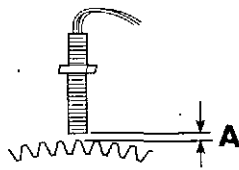

Fig. 12. Engine speed pickup's position in the flywheel housing

A. Distance 0,7-1,0 mm (0,028- 0,039")

Speed sender (pickup)

Screw in the pickup (with the engine stopped) until the top of the pickup touches the top of a tooth on the ring gear. Then screw the pickup out 3/4 turn and tighten the lock nut.

Connect the pickup to the control unit according to the wiring diagram (fig 8).

The voltage level of the pulses from the pickup should be at least 1V and max. 30V (AC RMS). The engine will stop if there is no signal.

Terminal "D" on the control unit is connected to ground. This grounds one side of the pickup internally.

The wires between the pickup and control unit must be shielded for their entire length. The shield must be connected to housing on the control unit.

Note! The shield should only be grounded at the control unit. Never ground at the pickup!

Crank the engine using the starter motor and check the voltage level from the pickup. The signal should be min. 1V (AC RMS).

Adjusting the actuator

ACB275 actuator

NOTE! When replacing the ACB275 actuator, the seal must be broken.

This involves some work on the injection equipment which can change the settings. The work must therefore be carried out by specially trained mechanics who have access to the necessary tools and test equipment.

All engine warranties are void if the seal should be broken by unauthorised personnel.

1. Remove the cover from the actuator (pos. 2, fig. 7).
2. **Basic setting:** Adjust linkage length so that when fastened to the operating lever the fuel rack is approx. 0,5-1,0mm (0.020-0.039") away from its extreme stop position.

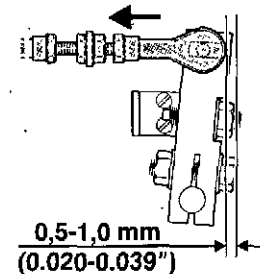

3. **Fine setting:** Connect ammeter and voltmeter according to fig. 13, and check the values according to table in fig. 13.

For the optimum function of the actuator, approx. half the actuator angle should be used. Adjust the link arm's length so that the values stated below are obtained both without load and with full load.

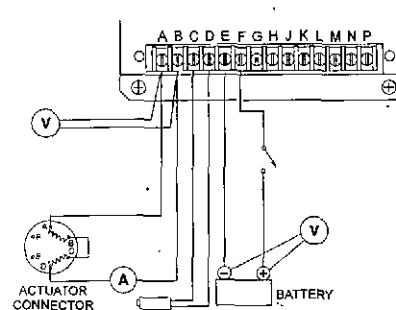

Load	Voltage A - B		Actuator current Amps		Battery Voltage E - F
	recorded	recommended	recorded	recommended	
No load	6,5 - 8,5	1,2 - 1,6	Nominal 24V
Full load	12 - 14	2,4 - 2,8

Fig. 13. Connecting the ammeter and voltmeter for fine adjustment of the actuator.

4. Adjust the fuel setting and seal the actuator.

Actuator ACB225

Max. angle travel of the actuator's lever is 25°.

1. **Basic setting:** Adjust the length of the link arm between the actuator and the injection pump's speed control lever.

The distance between the actuator flap and its stop should be approx. 10mm (3/8") (A, fig 14).

2. **Fine setting:** Use the same method/values as for the ACB275 actuator. See point 3 in the previous section.

Check that the actuator does not go to its end position at full output.

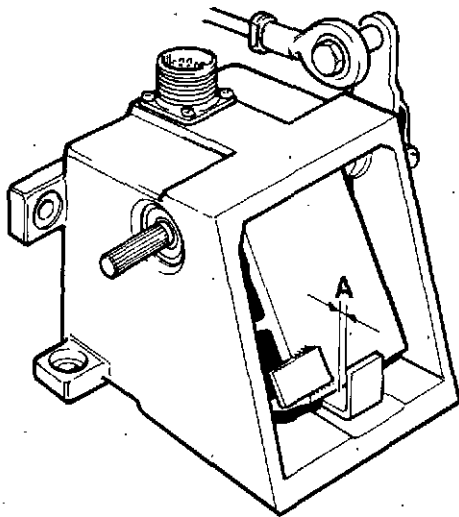

Fig. 14. Actuator ACB225

Basic setting
A=10 mm (3/8")

Running

Before the first start

Check the following before connecting the batteries:

1. That the system voltage is correct (12V or 24V).
2. That the polarity is correct at the "E" (minus) terminal on the control unit, and the "F" terminal (plus).

NOTE! The control unit has several built-in protections. Any possible short-circuiting of the actuator or the wires will stop the engine. After the batteries have been disconnected and the cause remedied, the unit will work correctly again.

Provided that a fast fuse is used in the battery cable as shown in the wiring diagram fig. 8, reversed polarity will not ruin the control unit. However, other incorrect connections can cause the control unit to be ruined.

3. That the wiring is otherwise correct. See wiring diagrams figs 8, 9 and 10.
4. Set the potentiometers "GAIN" and "STABILITY" in the control unit to the centre position.
5. Temporarily connect terminals "G" and "M" on the control unit to get low idle (approx. 600-800 r/min).

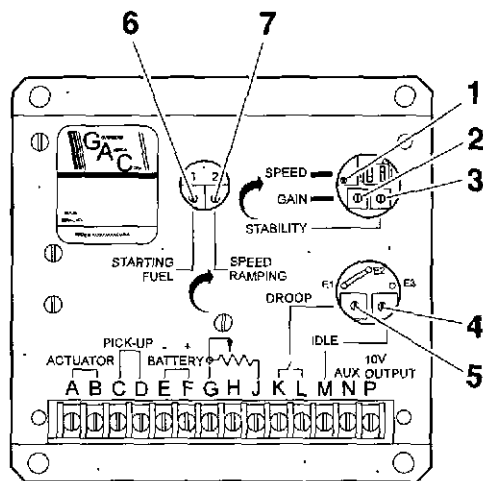

Fig. 15. The Control unit

1. Operating speed setting ("SPEED")
2. Sensitivity setting ("GAIN")
3. Stability control ("STABILITY")
4. Idle speed control ("IDLE")
5. Droop control ("DROOP")
6. Starting fuel adjustment ("STARTING FUEL")
7. Speed ramping adjustment ("SPEED RAMPING")

First start

1. Connect the batteries and start the engine. The governor should keep the engine at idle. If desired, the idle speed can be increased by turning the "IDLE" potentiometer clockwise. Note, this is a **single turn potentiometer**. Turn carefully and **not** to its end position.

Warning! Long periods of running at critical speeds can damage flexible couplings, the engine or the generator.

2. After the engine has been checked and its function is normal, remove the jumper between the "G" and "M" terminals on the control unit. The speed will increase to approx. 1567 r/min or 1870 r/min depending on the operating speed ordered.

For new, or previously adjusted control units, the "SPEED" potentiometer should be turned 2-3 turns clockwise from its end position for an engine speed of 1500 r/min to be obtained.

3. Perform a final adjustment of the "GAIN" and "STABILITY" in the control unit as follows:
 - Run the engine without load and turn the "GAIN" control **clockwise** until instability occurs. Then turn back the control until stability is obtained and then an additional 1/8 turn.
 - Adjust the "STABILITY" control in the same way as for the gain above. See also fig 16.

NOTE! When adjusting the sensitivity "GAIN", the set speed may be changed. Adjust, if necessary, using the "SPEED" potentiometer.

After these adjustments have been completed, load can be applied. It may be necessary to repeat the previous adjustments. Normally, there is a critical point for these adjustments with an unloaded, cold engine.

NOTE!

Turning the "GAIN" control clockwise will increase the governor reaction with changes in load. Turning counter-clockwise will give a slower reaction.

Turning the "STABILITY" control clockwise will shorten the time for the system's recovery after a change in load. Turning counter-clockwise will give a longer recovery time for the system.

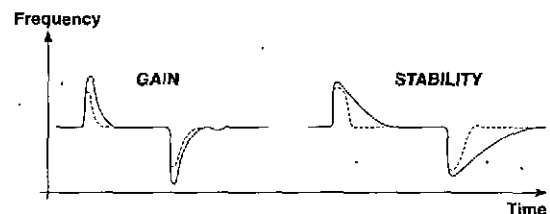
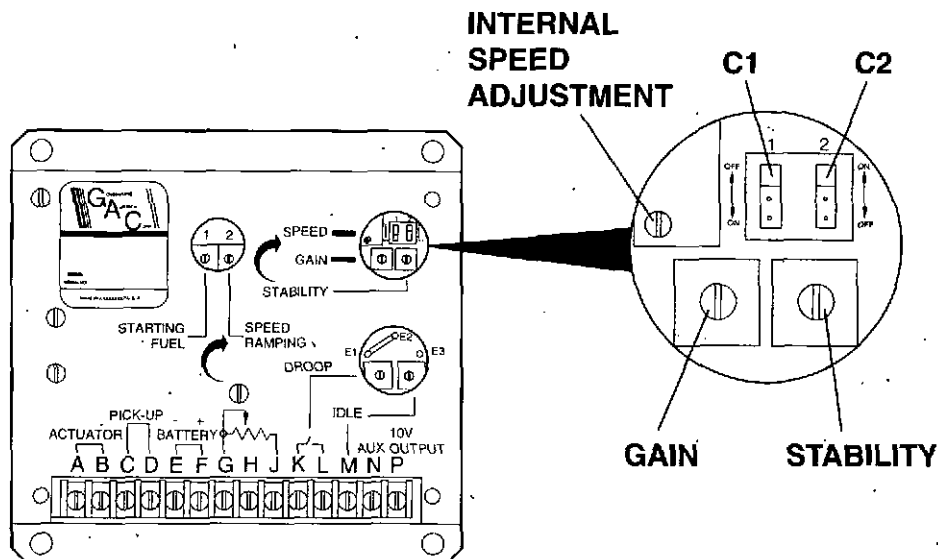

Fig 16. Stabilising process
Dashed line = best setting



Setting the dip switches C1 and C2:

The **left hand switch** (C1) replaces and functions as the jumper E6 to E7 found in the old control unit. The normal position is ON, corresponding the jumper in position on the old unit. Move the switch to the OFF position if there is fast instability in the system.

The **right hand switch** (C2) controls an additional circuit affecting the sensitivity of the control unit. With the switch in the ON position the sensitivity is being reduced. This function has been added in order to eliminate fast erratic engine behaviour which can be caused by a very soft or worn coupling in the power train between engine and driven object.

Note: Basic setting of switch C1 is in the ON position, and of switch C2 is in the OFF position. With the switches in these positions the ESD 5131 operates exactly like an ESD 5111.

Parallel Operation

For good load sharing when two or more generators are used in parallel operation, there are two suitable methods.

1.

As the electronic governor system works very exact and fast, its advantages can be used for parallel operation by using a load sharing system. If more information is required, contact Volvo Penta.

2.

The simplest method for load sharing is to use droop as used by mechanical governors.

For 4.5% droop at 1500 r/min (adjusted by Volvo Penta), terminals "K" and "L" on the control unit should be connected.

To run two engines together in parallel it must be possible to adjust the engine speed. A external speed trim potentiometer connected between terminals "G" and "J" on the control unit gives this possibility (fig 8, pos. 4).

Note. A 5Ω/2W potentiometer will give an adjustment range of ±200 r/min.

Before the generators are connected for parallel operation, each generator should be tested individually. This is done so that the droop is the same (4.5%) for all the connected generators.

The droop method is working well when two generators are run in parallel. The settings become more difficult when more generators are used.

If three or more generators are to be run in parallel, or when there are very high demands (e.g. operation of a radar or telecommunication plants) the method as described under point 1 should be considered.

Fault-tracing

1. Engine will not start

A. Battery voltage

Check the battery voltage at terminals "E" (-) and "F" (+) on the control unit.

Lowest permissible voltages at starter motor speed are:

- 8V DC for 12V system voltage.
- 17V DC for 24V system voltage.

Check that the fuse (fast) pos. 5, fig 8 is intact.

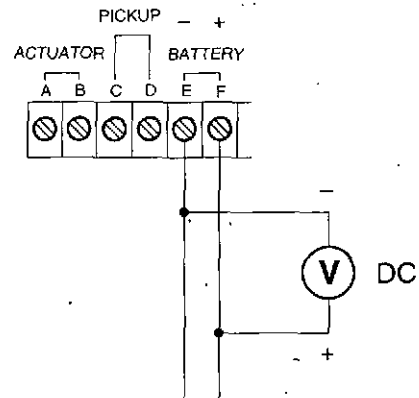

B. The actuator.

Break the power supply to the control unit. Loosen the angled connector on the actuator and check the actuator by measuring the resistance between the different connections using an ohmmeter. Move the governor flap backwards and forwards and note the ohmmeter readings.

If the actuator is working properly, the following values should be obtained:

Between connections:	A - B:	3±1 ohms
	C - D:	3±1 ohms
	A - C:	Infinity
	A - actuator casing:	Infinity
	C - actuator casing:	Infinity

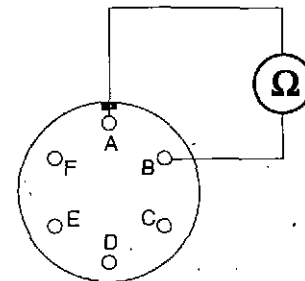

Fit the angled connector to the actuator and connect the power supply to the control unit.

Disconnect the wire from terminal "A" on the control unit and instead temporarily connect an ammeter in series between the wire and terminal "F". The actuator should then audibly move the control rod to the full fuel position. If necessary, remove the cover from the actuator to check the movement. Read off the ammeter. The current should be approx. 4A (12V) or 2,5A (for 24V system voltage).

NOTE! To remove the cover from the actuator, the seal must be broken. This may only be done by authorized service personnel (ACB 275 only).

All engine warranties are void if the seal should be broken by unauthorized personnel

If the actuator moves slowly despite the current being at the correct value (approx. 4A) the reason for this must be investigated (possibly it is the fuel rack in the injection pump sticking).

Check the wiring connections if the actuator does not move at all. If the connections are correct but the actuator still does not move, then replace the actuator.

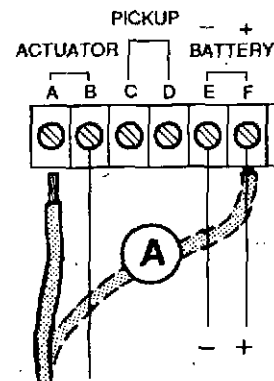

C. The pickup

Connect a voltmeter between terminals "C" and "D" on the control unit. Crank the engine using the starter motor and read off the voltage. It should be min. 1.0V (AC. RMS).

If there is no voltage: Disconnect the wires to terminals "C" and "D" and crank the engine again. If voltage is measured from the pickup then the control unit is faulty.

If there is still no signal from the pickup: Measure the resistance across terminals "C" and "D" on the control unit. The resistance should be between 50 and 250 Ohms. Otherwise, check the wiring and connections. If these are correct then the distance between the pickup and the flywheel ringgear must be checked. The distance should be 0.6 - 1.0 mm (0.024 - 0.039 ") (3/4 turn from the bottom position).

A reduction in distance will give a stronger signal (higher voltage) from the pickup.

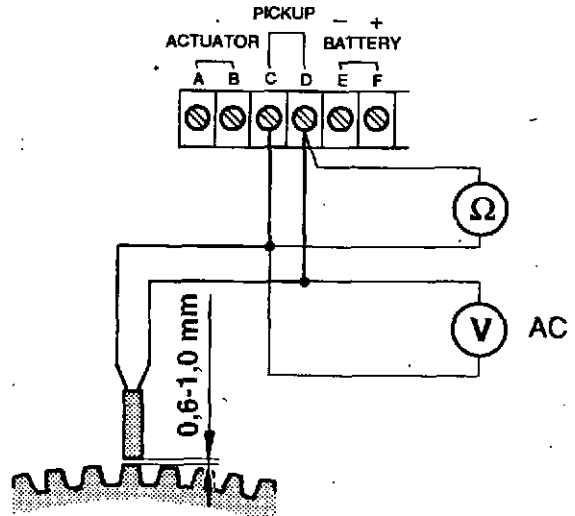

D. The control unit

1. Check the basic setting.
2. Check the voltage between terminals "G" (-) and "P" (+) on the control unit using a voltmeter. **Check the meter's polarity.**

The correct value is 10V DC (applies to engines with both 12V and 24V system voltage).

An incorrect value can be caused by a short-circuit at terminal "P" or a faulty "SPEED" potentiometer.

3. Connect a voltmeter between terminal "A" (-) and "F" (+) on the control unit. **Check the meter's polarity.**

Crank the engine using the starter motor and with the stop solenoid engaged. Check the voltmeter. The correct value is 1.5-2.5V DC (applies to engines with both 12v and 24Vsystem voltages).

An incorrect value can be caused by:

- "SPEED" potentiometer set too low.
- Wiring incorrect to the actuator.
- "SPEED" potentiometer faulty.

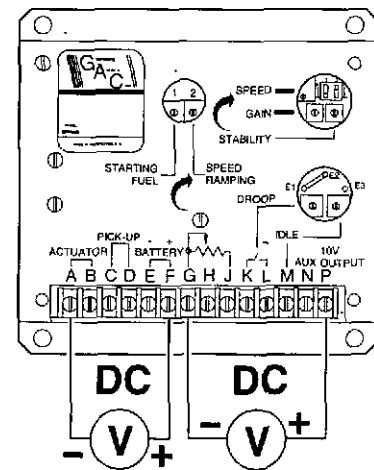

2. Engine overspeeds

1. Connect the power supply to the control unit. The actuator flap moves the fuel rack forward to max. fuel position.
2. Measure the voltage between terminals "A"(-) and "F"(+) on the control unit according to point 2, previous section.

Note! Do not crank the engine.

If the voltage is 1.5 - 2.5V DC, then the:

- "SPEED" adjustment is set too high.
- Control Unit is faulty.

If the voltage is above 2.5V DC, then the:

- Friction is too high in the actuator or in the linkage system.

If the voltage is below 1.5V DC, then the:

- Control unit is faulty.

Note. The above values apply to engines with both 12V and 24V system voltages.

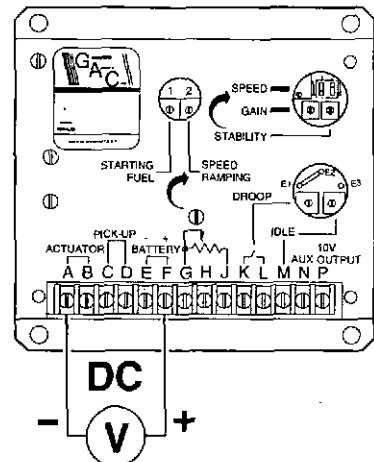

3. Disconnect the wires from the pickup at terminals "C" and "D" on the control unit.

- If the actuator is still in the max. fuel position, then the control unit is faulty.
- If the actuator is in the min. fuel quantity position, then the engine speed signal is incorrect. Check the wiring between the pickup and the control unit, and also the shield.

3. Engine does not reach required speed

1. Measure the voltage at the starting battery cables when the engine is cranked using the starter motor. The battery voltage must not be lower than 8V DC for a 12V system or 17V DC for a 24V system.

- Charge/replace the batteries if the battery voltage is too low. Make sure that the batteries are not underdimensioned.

- Incorrect wiring to the actuator.

2. Temporary connect a jumper between terminals "A" and "F" on the control unit. The actuator flap should then go forward to the max. fuel position. If it does not, then the cause is probably one of the following:

- Incorrect wiring to the control unit from the batteries or from the actuator.
- Actuator or linkage arms are sticking.
- Faulty actuator.

3. Measure the actuator voltage between terminals "A" and "B" on the control unit at the engine speed reached.

If the voltage is 2V or more compared to the battery voltage, then the fault is probably due to a sticking control rod, incorrect "overspeed springs" (applies to RQ governors), or a sticking linkage rod between the actuator and the injection pump.

If the fault persists after all the above points have been checked and everything appears to be in order, then try adjusting the "SPEED" potentiometer.

4. **Electrical interference and undesired droop**

If there is equipment installed nearby which emits radio frequency interference (RFI) e.g. electromagnets, semi-conductor type ignition systems, battery chargers or other electrical governors, then this can cause *unstable control* or *undesired droop* to be noticed. The control unit has built-in filters which provide some protection against this. High levels of interference must however be treated separately. The sources of interference must be isolated. Also, the wiring to the control unit must be routed as far as possible away from these sources of interference.

The wiring between the pickup and the control unit must be shielded along its entire length. Note that the shield should **only** be connected to terminal "D" on the control unit, and **never** at the pickup (see special wiring for EMS compliance, page 7).

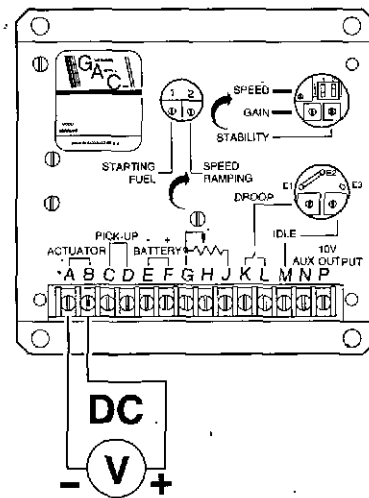
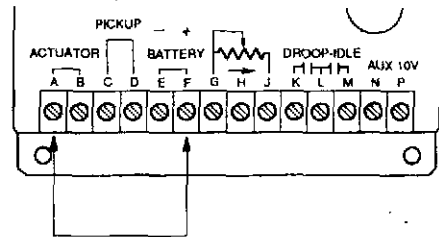
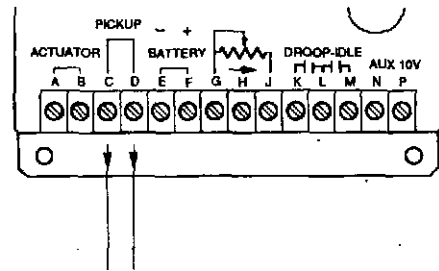

4. Hunting or unstable control

Hunting and unstable control are two problems which require special attention. If they should occur there could be many different, possible reasons of the problems.

If the system does not work satisfactory despite fault-tracing has been done as per sections 1-3, then contact the nearest GAC representative or Volvo Penta.

To provide fault-tracing assistance, the following questions must be answered:

1. What is the approximate frequency of the instability? (slow or fast)
2. What are the positions of the "GAIN" and "STABILITY" potentiometers in the control unit?
3. Does the instability frequency increase when the "GAIN" potentiometer is turned clockwise?
4. Does the instability disappear if the engine speed is temporarily increased or decreased?
5. Does the instability increase or decrease when the engine is loaded?
6. What happens if the jumper "A" between E1 and E2 on the control unit is cut?
7. What happens if an additional capacitor ("B"), value $10\mu\text{F}$, is connected between terminals E2 and E3 according to the figure? **NOTE! E3 is plus (+).**
8. Does the complete governor system, including the stop lever, linkage rod and control rod, move freely without the slightest sign of sticking?
9. Has the actuator current been measured from zero load to full load according to the figure?

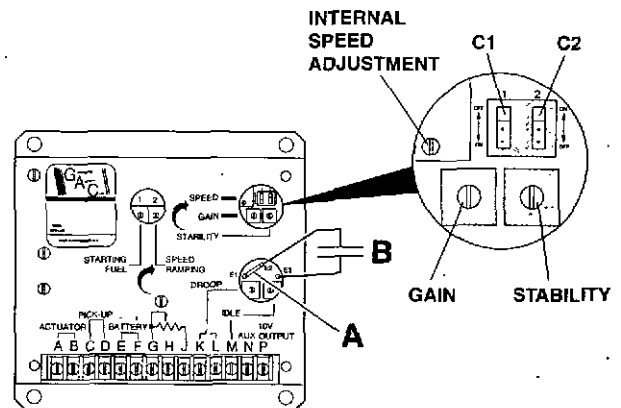
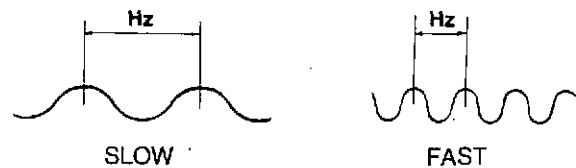

- A Jumper (connection)
B. Capacitor ($10\mu\text{F}$)

Depending on the answers to the above questions, the instability can be caused by:

1. "GAIN" and/or "STABILITY" potentiometers adjusted too high.
2. Too high sensitivity in the control unit in relation to the mass and inertia of the driven units.
3. If a flexible coupling is fitted, stiffness, clearance or torsional vibrations.
4. The injection pump.
5. The linkage system.
6. The alternator unit's voltage regulator.
7. The signal from the pickup.

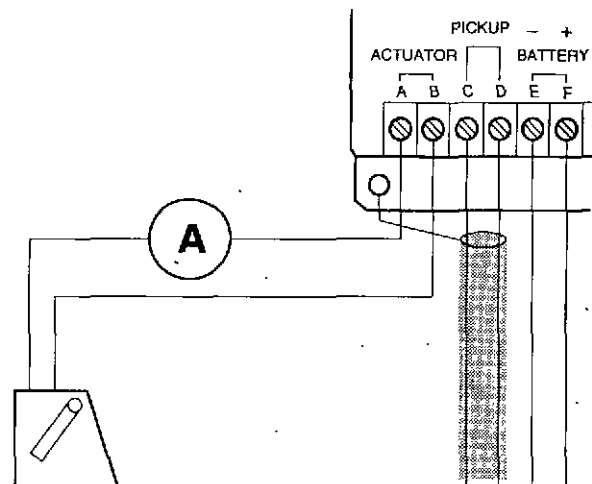

Checking the actuator current

Recordings during testing

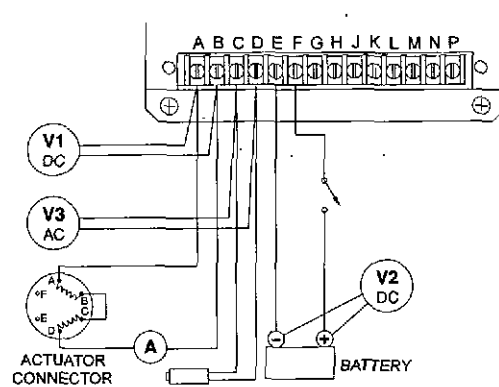

24 V:

Load	Voltage A - B (V1)		Actuator Current Amps		Battery Voltage (V2)	Voltage (V3)
	recorded	recommended	recorded	recommended	E - F	Speed Sensor
No load	6,5-8,5	1,2-1,6	Nominal 24 Volt	Starting.....
Full Load	12-14	2,4-2,8	Nom. Speed....

12 V:

Load	Voltage A - B (V1)		Actuator Current Amps		Battery Voltage (V2)	Voltage (V3)
	recorded	recommended	recorded	recommended	E - F	Speed Sensor
No load	2,9-3,3	2,3-2,6	Nominal 12 Volt	Starting.....
Full Load	4,9-5,4	3,9-4,3	Nom. Speed....

**VOLVO
PENTA**