

Function - Installation

Electronic Speed Governor

DE

2(0)

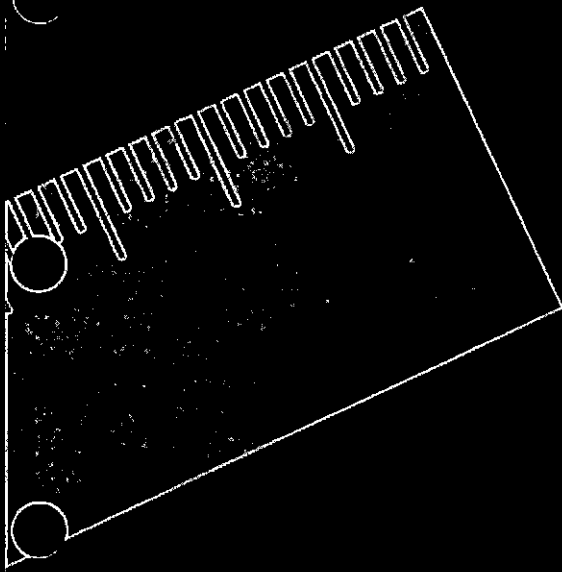

**VOLVO
PENTA**

Electronic Speed Governor

Function – Installation – Fault-tracing

This booklet only covers the ACB225, ACB275 and ACD175-24 actuators and the ESD5500E control unit.

Genset applications:

Note. If the GAC system is to be used for a genset application, please contact Hügli Tech Ltd. (Switzerland) for application assistance.

- telephone: INT +41-62 9165030
- telefax: INT +41-62 9165035
- e-mail: hueglitechag@bluewin.ch

Contents

Safety precautions	2
General information	5
General description	7
Function	8
Installation	11
Electromagnetic compatibility	12
Setting and Adjusting	13
Running	15
Fault-tracing	17

Safety Precautions

Introduction

This Service Manual contains technical specifications, installation instructions and wiring diagrams for the Electronic Speed Governor.

If you do not understand or are uncertain about any operation or information in this Manual, please contact your Volvo Penta dealer for assistance.

Read the "Safety Precautions" and the "General Information" carefully before starting work.

Important!

In this book and on the engine you will find the following special warning symbols.

 **WARNING!** Possible danger of personal injury, damage to property or mechanical malfunction if the instructions are not followed.

 **IMPORTANT!** Used to attract attention to what can cause injury, malfunction, or damage to property.

NOTE! Used to attract attention to important information for the simplification of work processes or handling.

To provide a general understanding of the risks and precautions to which attention should always be given we have made the following list.

 Plan work in advance to ensure that there is sufficient space to remove components without danger of injury or damage. Plan the engine compartment (and other compartments such as the battery compartment) so that all service points are accessible. Take precautions so that you do not come into contact with rotating components, hot surfaces or sharp edges when servicing or inspecting the engine. Ensure that all equipment (pump or compressor drives for example) are equipped with suitable safety guards.

 Immobilize the engine by turning off the power supply to the engine at the main switches so it is impossible to start, and lock them in the OFF position before starting work. Set up a warning notice at the engine control point or helm.

 As a general rule all service operations must be carried out with the engine stopped. Some work, e.g. certain adjustments, require the engine to be running. Approaching an engine which is running is a safety risk. Remember that loose clothes or long hair can fasten in rotating parts and cause severe personal injuries. If working in proximity of an engine which is operating, careless movements or a dropped tool can result in personal injury. Take care to avoid contact with hot surfaces (exhaust pipes, Turbocharger (TC), air intake pipe, start element etc.) and hot liquids in lines and hoses on an engine which is running or which has just been stopped. Reinstall all protective parts removed during service operations before starting the engine.

 Check that the warning or information decals on the engine are always clearly visible. Replace decals that have been damaged or painted over.

 Never start the engine without installing the air cleaner (ACL). The rotating compressor in the Turbo can cause serious personal injury. Foreign objects entering the intake ducts can also cause mechanical damage.

 Never use start spray or similar to start the engine. The start spray may cause an explosion in the inlet manifold. Danger of personal injury.

 Avoid opening the coolant filler cap when the engine is hot. Steam or hot coolant can spray out as system pressure is lost. Open the filler cap slowly and release coolant system pressure, if the filler cap or a drain cock/venting cock must be opened, or if a plug or engine coolant line must be removed on a hot engine. It is difficult to anticipate in which direction steam or hot coolant can spray out.

 Hot oil can cause burns. Avoid skin contact with hot oil. Ensure that the lubrication system is not under pressure before commencing work on it. Never start or operate the engine with the oil filler cap removed, otherwise oil could be ejected.

 Stop the engine and close the sea cock before carrying out operations on the engine cooling system.

- ⚠ Only start the engine in a well-ventilated area. If operating the engine in a closed area ensure that there is exhaust ventilation leading out of the work area to remove exhaust gases and crankcase ventilation emissions.
- ⚠ Always use protective goggles where there is a danger of pieces of metal, sparks from grinding, acid or other chemicals being thrown into your eyes. Your eyes are very sensitive, injury can lead to loss of sight!
- ⚠ Avoid skin contact with oil. Long-term or repeated contact with oil can remove the natural oils from your skin. The result can be irritation, dry skin, eczema and other skin problems. Used oil is more dangerous to health than new oil. Use protective gloves and avoid oil-soaked clothes and rags. Wash regularly, especially before meals. Use the correct barrier cream to prevent dry skin and to make cleaning your skin easier.
- ⚠ Most chemicals used in products (engine and transmission oils, glycol, petrol and diesel oil) and workshop chemicals (solvents and paints) are hazardous to health. Read the instructions on the product packaging carefully! Always follow safety instructions (using breathing apparatus, protective goggles and gloves for example). Ensure that other personnel are not unwittingly exposed to hazardous substances (by breathing them in for example). Ensure that ventilation is good. Handle used and excess chemicals according to instructions.
- ⚠ Be extremely careful when tracing leaks in the fuel system and testing fuel injection nozzles. Use protective goggles! The jet ejected from a fuel injection nozzle is under very high pressure. It can penetrate body tissue and cause serious injury. There is a danger of blood poisoning.
- ⚠ **WARNING!** Delivery pipes must not be bent, twisted or subjected to other stress. Replace damaged delivery pipes.
- ⚠ All fuels and many chemicals are inflammable. Ensure that a naked flame or sparks cannot ignite fuel or chemicals. Combined with air in certain ratios, petrol, some solvents and hydrogen from batteries are easily inflammable and explosive. Smoking is prohibited! Ensure that ventilation is good and that the necessary safety precautions have been taken before carrying out welding or grinding work. Always have a fire extinguisher to hand in the workplace.
- ⚠ Store oil and fuel-soaked rags and fuel and oil filters safely. In certain conditions oil-soaked rags can spontaneously ignite. Used fuel and oil filters are environmentally dangerous waste and must be deposited at an approved site for destruction together with used lubricating oil, contaminated fuel, paint remnants, solvent, degreasing agents and waste from washing parts.
- ⚠ Ensure that the battery compartment is constructed according to applicable safety regulations. Never allow a naked flame or electric sparks near the batteries. Never smoke in proximity to the batteries. The batteries give off hydrogen gas during charging which when mixed with air can form an explosive gas - oxyhydrogen. This gas is easily ignited and highly volatile. Incorrect connection of the battery can cause a spark which is sufficient to cause an explosion with resulting damage. Do not disturb battery connections when starting the engine (spark risk) and do not lean over batteries.
- ⚠ Never mix up the positive and negative battery terminals when installing. Incorrect installation can result in serious damage to electrical equipment. Refer to wiring diagrams.
- ⚠ Always use protective goggles when charging and handling batteries. The battery electrolyte contains extremely corrosive sulfuric acid. If this should come in contact with the skin, immediately wash with soap and plenty of water. If battery acid comes in contact with the eyes, immediately flush with plenty of water and obtain medical assistance without delay.
- ⚠ Turn the engine off and switch off power at the main switches before carrying out work on the electrical system.
- ⚠ Clutch adjustments, where a clutch is fitted, must be carried out with the engine turned off.
- ⚠ Use the lifting eyes mounted on the engine/reverse gear when lifting the drive unit. Always check that the lifting equipment used is in good condition and has the load capacity to lift the engine (engine weight including reverse gear and any extra equipment installed).

 To ensure safe handling and to avoid damaging engine components on top of the engine, use a lifting beam to raise the engine. All chains and cables should run parallel to each other and as perpendicular as possible in relation to the top of the engine.

If extra equipment is installed on the engine altering its center of gravity, a special lifting device is required to achieve the correct balance for safe handling.

Never carry out work on an engine suspended on a hoist.

 Never handle heavy components alone, even where secure lifting equipment such as secured blocks are being used. Even where lifting equipment is being used it is best to carry out the work with two people; one to operate the lifting equipment and the other to ensure that components are not trapped and damaged when being lifted.

When working on-board ensure that there is sufficient space to remove components without danger of injury or damage.

 **WARNING!** The components in the electrical system and in the fuel system on Volvo Penta products are designed and manufactured to minimize the risk of fire and explosion.

The engine must not be run in areas where there are explosive materials.

 Always use fuels recommended by Volvo Penta. Refer to the Instruction Book. The use of lower quality fuels can damage the engine. On a diesel engine poor quality fuel can cause the control rod to seize and the engine to overrev with the resulting risk of damage to the engine and personal injury. Poor fuel quality can also lead to higher maintenance costs.

 Observe the following rules when cleaning with high-pressure water jets. Never direct the water jet at seals, rubber hoses or electrical components. Never use a high pressure jet when washing the engine.

General

This Manual is primarily intended for use by expert professionals. Persons using this book are assumed to have a basic knowledge and be able to carry out related mechanical and electrical work.

The mechanic is responsible for ensuring that installation is carried out correctly, that only approved materials and equipment is used, that function tests are carried out after installation, and that the installation meets all applicable regulations.

Volvo Penta is continuously developing their products. We therefore reserve the right to make changes. All the information contained in this book is based on product data available at the time of going to print. Any important modifications to the product or changes to installation methods after the date of going to press will be notified in Service Bulletins.

Plan installation carefully

Plan the installation of the engine and its components carefully in advance. Always ensure that the correct drawings, Wiring Diagrams and data are used, and that all installation drawings, templates, technical and other necessary data are available before starting work. This will prevent problems in the planning phase and during installation.

Plan the engine compartment so that regular service and maintenance can be carried out and so that components can be replaced easily. Compare the service literature for the engine with the drawings so that there is enough room to service the engine.

It is of the greatest importance that no dirt or foreign particles get into the fuel system, cooling system or intake system when installing the engine. This could lead to malfunction or serious damage. Blow clean all pipes and hoses with compressed air before connecting them to the engine. Remove the engine plugs only when connecting the engine to external systems.

Certificated engines

For service and repair of an engine certificated for any area where exhaust emissions are regulated by law, the following is important:

Certification means that an engine type is inspected and approved by the authorities. The engine manufacturer guarantees that all engines manufactured of that type correspond to the certified engine.

This places special requirements on maintenance and service as follows:

- The maintenance and service intervals recommended by Volvo Penta must be observed.
- Only genuine Volvo Penta replacement parts may be used.
- The service of injection pumps and injectors or pump settings must always be carried out by an authorized Volvo Penta workshop.
- The engine must not be modified in any way except with accessories and service kits approved by Volvo Penta.
- No modifications to the exhaust pipes and air supply ducts for the engine may be undertaken.
- Seals may only be broken by authorized personnel.

Otherwise the general instructions contained in the Instruction Manual concerning operation, service and maintenance must be followed.



IMPORTANT! Late or inadequate maintenance/ service or the use of spare parts other than genuine Volvo Penta original spare parts will invalidate AB Volvo Penta's responsibility for the engine specification being in accordance with the certificated variant.

Volvo Penta accepts no responsibility or liability for any damage or costs arising due to the above.

Joint responsibility

Each engine consists of many connected systems and components. If one component deviates from the technical specifications this can have dramatic consequences on the environmental impact of the engine. It is therefore vital that systems that can be adjusted are adjusted properly and that Volvo Penta Genuine Parts are used.

Certain systems (components in the fuel system for example) may require specialist expertise and test equipment. Some components are sealed at the factory for environmental reasons. No work should be carried out on sealed components except by authorized personnel.

Bear in mind that most chemicals are harmful to the environment if used incorrectly. Volvo Penta recommends the use of biodegradable degreasing agents for cleaning engine components, unless otherwise stated in a workshop manual. Take special care that oil and waste is taken for destruction and is not accidentally pumped into the environment.

General description

The electronic governor system is a control unit which governs the engine speed. Its task is to:

- maintain the idling speed at an adjustable set point
- maintain the engine's operating speed at an adjustable set point despite varying loads.

Unlike the mechanical governor, the electronic governor does not have governor weights. The speed is controlled by the control unit (1, fig 1) "sensing" the difference between the set speed and the actual speed.

The difference value is converted into a signal to an electro-magnet (actuator) which adjusts the injection pump's control rod to increase or decrease the injected fuel amount.

The following text describes the components making up the system, and their function, separately.

Certain engines have injection pumps with RQ governors fitted as speed limiters. In these cases the actuator is fitted on a separate bracket. The sender and the electronic overspeed protection is omitted in these cases, and the stop solenoid/fuel shut off valve is only used to stop the engine normally.

⚠ WARNING!

An overspeed protection **MUST** always be fitted besides the electronic governor to prevent bodily injury or material damage if the engine should run out of control.

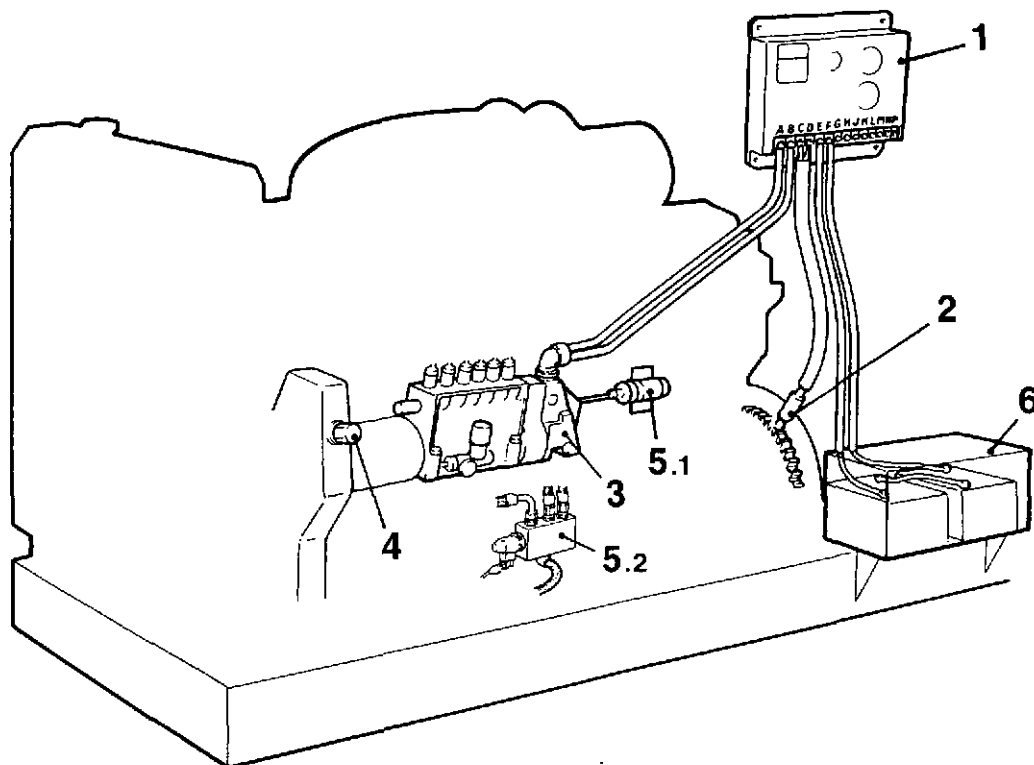

Fig. 1. Engine fitted with an electronic governor (system diagram)

- | | |
|---|-------------------------|
| 1. Control unit | 5.1 Stop solenoid |
| 2. Engine speed pickup | 5.2 Fuel shut-off valve |
| 3. Actuator | 6. Batteries |
| 4. Engine speed pickup for overspeed protection | |

Function

Engine speed pickup

The engine speed pickup is a variable reluctance sensor fitted in the flywheel housing directly above the flywheel ring gear. As the teeth of the ring gear pass under the electromagnet an **alternating current** is induced (one cycle per tooth).

The pulse's voltage is between 1V AC to 30V (AC, RMS.)

The pickup's threads is 5/8"-18 UNF-2A.

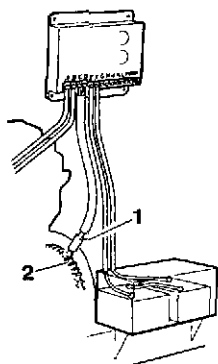

Fig. 2. Location of engine speed pickup

1. Engine speed pickup
2. Flywheel ring gear

Control unit

The electronic control Unit (fig 3) compares the incoming signals with the pre-set values, and a correcting signal or an unchanged signal is transmitted to the actuator.

The control unit has a number of adjustment possibilities which are described below. Adjustments can be made after first removing the round rubber plugs from the control unit.

1. **Adjusting the idling speed** (marked "IDLE"), (4, fig. 3) is done with a single turn potentiometer. The idling speed can be adjusted with a jumper between the terminals "G" and "M" installed.

The adjustment range is 1200-4100 Hz below the frequency for the set engine speed. Turning the potentiometer **clockwise will increase** the idling speed.

2. **Adjusting the operating speed** ("SPEED"), (1, fig. 3) is done with a 22 turn potentiometer.

The frequency range is 1000-7500 Hz. Turning the potentiometer **clockwise will increase** the engine speed.

The frequency from the magnetic pickup (engine speed pickup) is dependent on the number of teeth on the flywheel ring gear and the desired engine speed, i.e. the engine speed in r/s (revs per second) multiplied by the number of teeth on the ring gear.

Engine	No. of teeth
6 Ltr. engines	140
7 Ltr. engines (standard/optional*)	140/153*
10/12 Ltr. engines	156
16 Ltr. engines	153

*Flywheel housing with connection acc. to SAE 1.

Example: Engine TWD1630 set on 1500 rpm.
(25 r/s):

$$25 \times 153 = 3825 \text{ Hz.}$$

3. **Governor sensitivity.** The governor's sensitivity is adjusted by a single turn potentiometer ("GAIN"), (1, fig. 3). A small change of frequency can be noticed when adjusting the "GAIN" control. This can be adjusted by the "SPEED" potentiometer (3).
4. **Stability control.** The governor's time constant is adjusted by the single turn potentiometer ("STABILITY"), (7, fig. 3).

The time constant is the time required by the engine to return to the set operating speed after there has been a change in load.

5. **Droop.** The droop control (4, fig. 3), marked "DROOP" is working when terminals "K" and "L" are connected. The adjustment range is 1-5%. Turning **clockwise will increase** the value.

With a jumper between terminals "G" and "H", an increased droop can be obtained.

6. **Starting fuel adjustment.** Turning the "STARTING FUEL" adjustment **clockwise** will increase the amount of fuel delivered to the engine during cranking. With the adjustment **full counter-clockwise**, the fuel amount will be very low or zero depending on the actuator linkage. With the adjustment **full clockwise**, starting fuel is unlimited and the actuator will move to 100% fuel during cranking.
7. **Speed Ramping Adjustment.** Turning the "SPEED RAMPING" adjustment **clockwise** will slow the acceleration of the engine speed. With the adjustment **full clockwise**, the acceleration can be as long as 20 seconds depending on the speed range selected. With the adjustment **full counter-clockwise**, the ramping will be effectively eliminated.

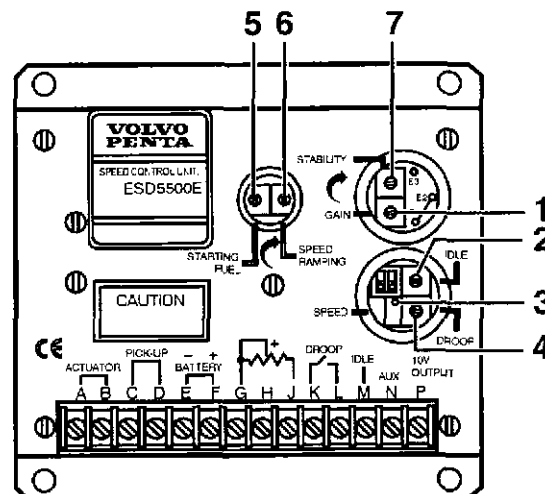

Fig. 3. Control unit ESD5500E with the rubber plugs removed.

1. Gain control
2. Idle adjustment
3. Operating speed, setting
4. Droop control
5. Starting fuel adjustment
6. Speed ramping adjustment
7. Stability control

Speed Control Unit ESD5500E

Introduction

The ESD5500E Series speed control unit includes all of the features of the ESD5131. In addition, it includes a feature that controls the fuel delivered to the engine during the starting process. By eliminating excess fuel, less smoke is produced resulting in environmental benefits. It has also been improved to reach higher EMC immunity. Replacement of older speed controls on existing engines is a simple and environmentally responsible process.

The only difference between the installation of an ESD 5500E and that of the ESD5100 Series is the Idle selector switch connections. The ESD5500E uses Terminals "M" and "G" while the ESD5100 used Terminals "M" and "L".

Adjustment description

The performance adjustments of the ESD5500E are set exactly like those of the ESD5100 Series. The STARTING FUEL and SPEED RAMPING adjustments control the start up characteristics of the engine. With proper adjustment, a smooth start, with minimum excess fuel, can greatly reduce excessive smoke during engine starting.

Starting fuel adjustment

Turning the STARTING FUEL adjustment **clockwise** will increase the amount of fuel delivered to the engine during cranking. With the adjustment **full counter-clockwise**, the fuel amount will be very low or zero depending on the actuator linkage. With the adjustment **full clockwise**, starting fuel is unlimited and the actuator will move to 100% fuel during cranking.

Speed Ramping Adjustment

Turning the SPEED RAMPING adjustment **clockwise** will slow the acceleration of the engine speed. With the adjustment **full clockwise**, the acceleration can be as long as 20 seconds depending on the speed range selected. With the adjustment **full counter-clockwise**, the ramping will be effectively eliminated.

Adjustments

Preset the ESD5500E as follows:

- STARTING FUEL: Full clockwise (Maximum fuel)
 - SPEED RAMPING: Full counter-clockwise (Fastest)
1. Start the engine and adjust the Speed, Gain, Stability and Dead Time Compensation (switches "C1" and "C2") as described on pages 15-16. The fuel delivery should not be restricted at this time.
 2. Place the engine in idle by connecting Terminals "M" and "G".
 3. Adjust the IDLE speed for as low speed setting as the application allows.

4. Adjust the STARTING FUEL **counter-clockwise** until the engine speed begins to fall. Increase the STARTING FUEL slightly so that the idle speed is returned to the desired level.
5. Stop the engine.

One of two methods of operation for the ESD5500E may now be selected.

Method 1 – Start the engine and accelerate directly to the operating speed (Gen sets, etc.).

or

Method 2 – Start the engine and control at an idle speed for a period of time prior to accelerating to the operating speed. This method separates the starting process from the acceleration process so that each may be optimized for the lowest smoke emissions.

Method 1

Remove the connection between Terminals "M" and "G". Start the engine and adjust the SPEED RAMPING for the least smoke on acceleration from idle to rated speed. If the starting smoke is excessive, the STARTING FUEL may need to be adjusted **slightly counter-clockwise**. If the starting time is too slow, the STARTING FUEL may need to be adjusted **slightly clockwise**.

Method 2

Replace the connection between Terminals "M" and "G" with a switch, usually an oil pressure switch. Start the engine. If the starting smoke is excessive, the STARTING FUEL may need to be adjusted **slightly counter-clockwise**. If the starting time is too long, the STARTING FUEL may need to be adjusted **slightly clockwise**.

When the switch opens, adjust the SPEED RAMPING for the least amount of smoke when accelerating from idle speed to rated speed.

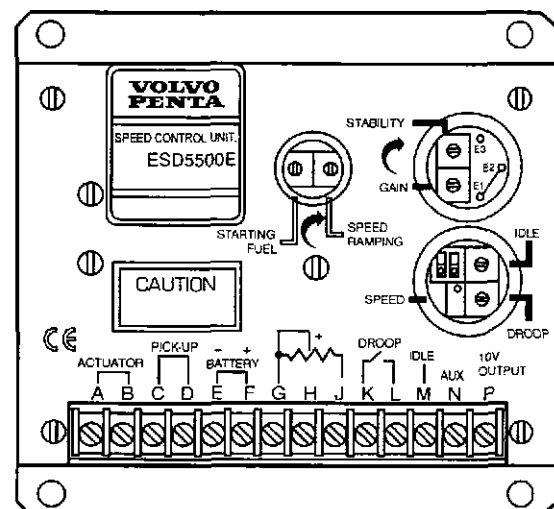

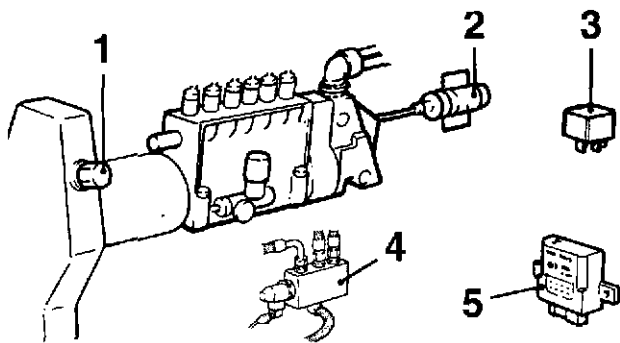

Fig. 4. Engine with electronic overspeed protection

- | | |
|-----------------------------|-------------------------|
| 1. Engine speed pickup | 4. Fuel shut-off valve |
| 2. Stop solenoid* | 5. Overspeed protection |
| 3. Relay for stop solenoid* | |

* Engines fitted with the ACD175-24 actuator have no stop solenoid. Instead, a fuel shut-off valve (4) is fitted.

Overspeed protection

As an extra safety protection against overspeed and consequent damage, a separate overspeed protection must be included in the electronic governor system.

The engine speed pickup for the overspeed protection is fitted in the timing gear casing. The overspeed protection should be set so that the operating speed can be exceeded by approx. 15%. The adjustment is done using the trim potentiometer (C/D, fig 5).

At the pre-set shut-down point, the stop solenoid (if fitted)* and the control unit should be de-energized simultaneously, moving the injection pump's stop lever to the zero fuel position thus stopping the engine.

If the engine is fitted with a RQ governor, then this will function as an overspeed protection. The RQ governor limits the engine speed mechanically.

An overspeed protection must always be installed for safety reasons.

*Note. A stop solenoid is not required for the ACB275 and ACD175-24 actuators.

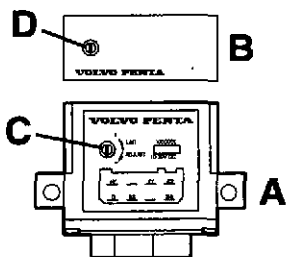

Fig. 5. Electronic overspeed protection

- | | |
|--------------|--|
| A. Version 1 | C, D. Adjuster screws for setting the shut-down point* |
| B. Version 2 | |

*One turn of the adjuster screw "C" corresponds to approx. 70 rpm for the 16 liter range (or approx. 85 rpm for other engines that have later been equipped with the overspeed protection). The adjustment sector (270°) for screw "D" corresponds to approx. 1560-2700 rpm.

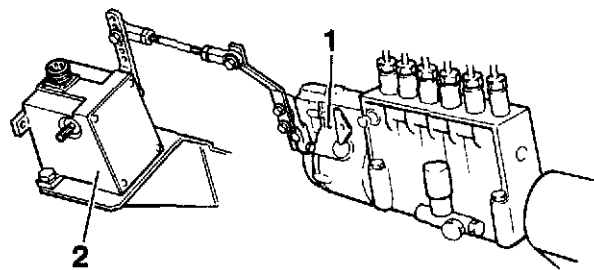

Fig. 6. Engine with mechanical overspeed protection

- | | |
|----------------|----------------------------------|
| 1. RQ governor | 2. Separately installed actuator |
|----------------|----------------------------------|

Actuator

The actuator is an electromagnet. The actuator, type ACB275 or ACD175-24, is fitted to the rear of the injection pump and replaces the usual mechanical governor.

On certain injection pumps there is an RQ governor fitted as an overspeed protection. For these cases, an actuator type ACB225 is fitted separately.

The control signals, which the control unit transmits to the actuator, are transferred to the injection pump's fuel control rod via a linkage system.

The actuator converts the control signals from the control unit to controlling forces.

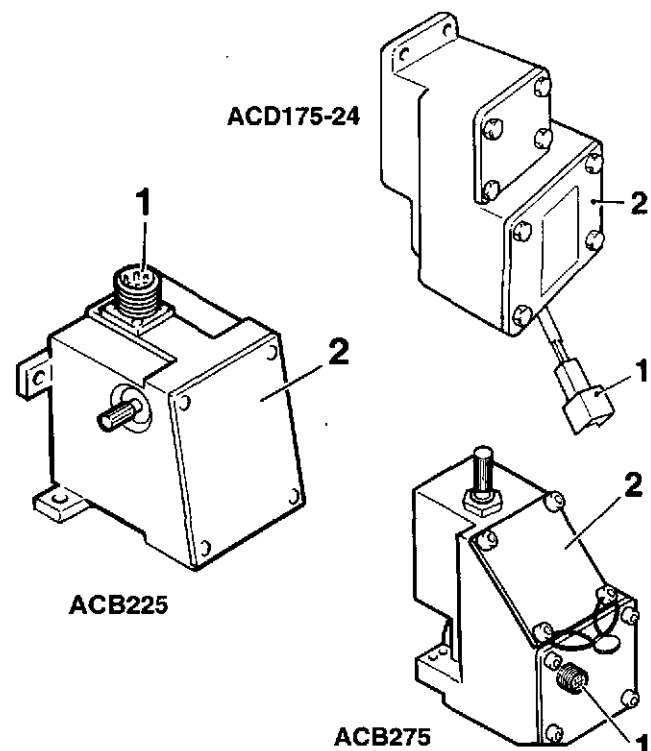

Fig. 7. Actuators, type ACB225, ACB275 and ACD175-24

- | |
|-----------------------------------|
| 1. Connection to the control unit |
| 2. Inspection cover |

Power supply

The power supply can be either 12V or 24V DC for the actuators ACB225 and ACB275. For the ACD175-24 actuator the power supply is 24V DC.

No ground circuit is required as the circuits are isolated from the control unit's casing.

Max. current at 24V is approx. 4A, and at 12V approx. 8A. The control unit should be fused with a 15A for 12V, and 8A for 24V, fast typed fuse.

Note! A battery charger must not be connected so that overvoltage occurs in the system.

Location of the control unit

The control unit should be placed in a protected place which is not subject to extreme vibrations or temperatures. The control unit functions well at temperatures between -40°C to $+85^{\circ}\text{C}$ (-40° to $+185^{\circ}\text{F}$).

Wiring

The wiring is shown in the wiring diagram, fig 8.

Note that all components are connected to the control unit (two cables each from the actuator, pickup and battery).

12V* Jumper A to C
Jumper B to D

* Not applicable for ACD175-24

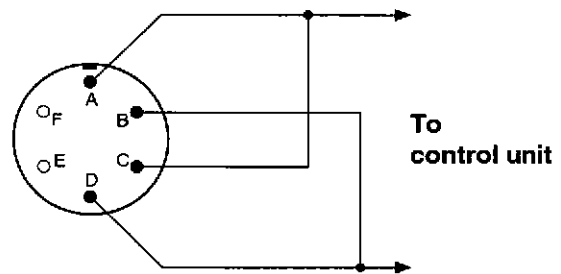

Fig. 9. Connecting the actuator for 12V system voltage.

Note. Also connect a jumper between terminals "G" and "H" on the control unit.

24V Jumper B to C
A & D connected to the control unit

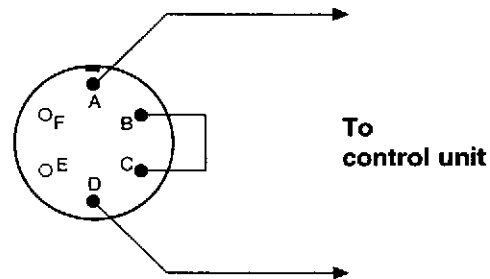

Fig. 10. Connecting the actuator for 24V system voltage

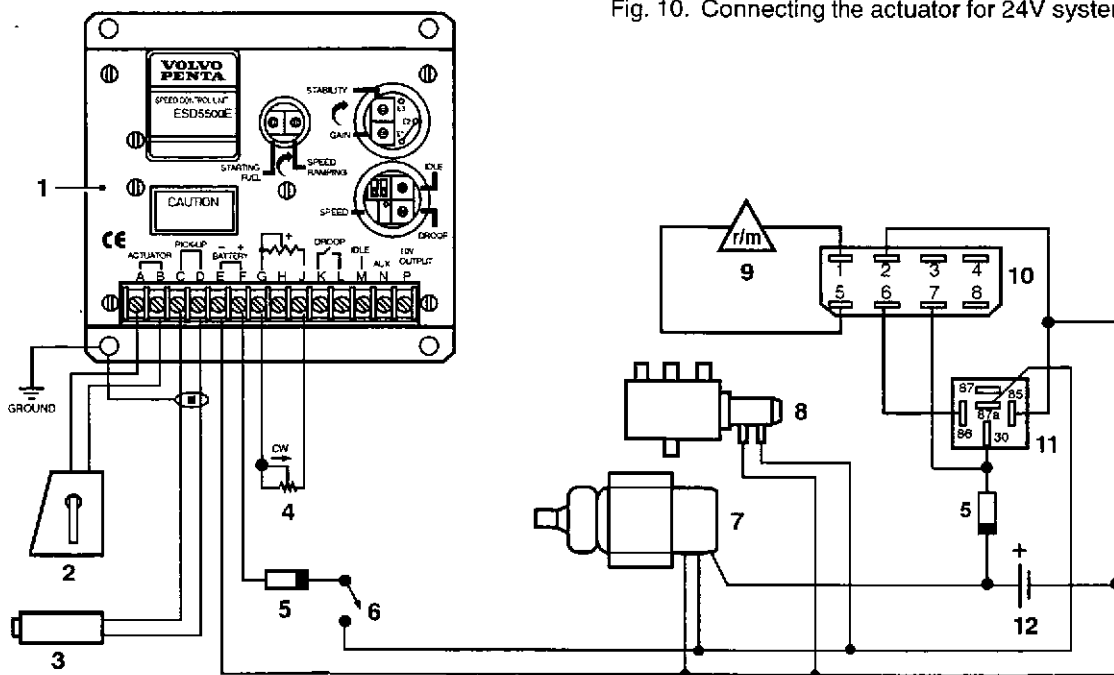

Fig. 8. Connecting the stop solenoid or fuel valve, live during operation, 24V system.

Note. The later version stop solenoid has a built-in transient protection. Therefore, only a separate transient protection (7) for the control unit is required.

- | | | |
|--|-----------------------------------|---|
| 1. Control unit | 5. Fuse 15A (fast) | 9. Engine speed pickup for overspeed protection |
| 2. Actuator | 6. Main switch | 10. Engine speed switch (overspeed protection) |
| 3. Pickup | 7. Stop solenoid (not for ACD175) | 11. Relay |
| 4. External speed trim (5 k Ω) | 8. Fuel shut off valve | 12. Battery: 12V or 24V |

Wiring

The 6 basic wires should have the following min. cross-section in mm²:

Terminal	12V		24V	
	up to 6 Meters (19.7 feet)	over 6 Meters (19.7 feet)	up to 6 Meters (19.7 feet)	over 6 Meters (19.7 feet)
A - B to actuator	2.5	4.0	1.5	2.5
E - F to battery	2.5	4.0	1.5	2.5
C - D to speed sensor	Use shielded cable 2 x 0.75 or 2 x 1.0 mm ² . Connect shield to ground terminal on control unit. If shielded cable is not available, then twist the two leads all the way.			
Other terminals (if used)	Conduct only milliamps, hence 1.0 mm ² is sufficient. In case of strong electro-magnetic fields use only shielded cables. Shield to terminal "G".			

Electromagnetic compatibility

In order to be in compliance with the EMC directives, the installer is obligated to install the equipment in strict accordance with the following special instructions and guidelines:

1. The speed control unit must be mounted against a metal ground plane with four bolts which make positive electrical connection between the control unit casing and the back plane or a backing plate.
2. The magnetic pickup must be connected to the control unit using shielded cable as shown in the wiring diagram, fig. 11.
3. All shielded cable connections to the control unit must be connected to the casing.
4. The battery minus connection to terminal "E" must also be additionally jumpered to the control unit casing. For isolated ground systems use a 0.01 μF capacitor. The capacitor should be a good quality ceramic type that withstand the required isolation voltage (500V - 1kV).
5. Shielded cable for the actuator is recommended to minimise the actuator's slight movement during fast high voltage transients. The installer's choice of not using shielded cable may cause the actuator to move more than slightly during these transients. However, no failures should be experienced.
6. The installer must refer to the wiring diagram below.

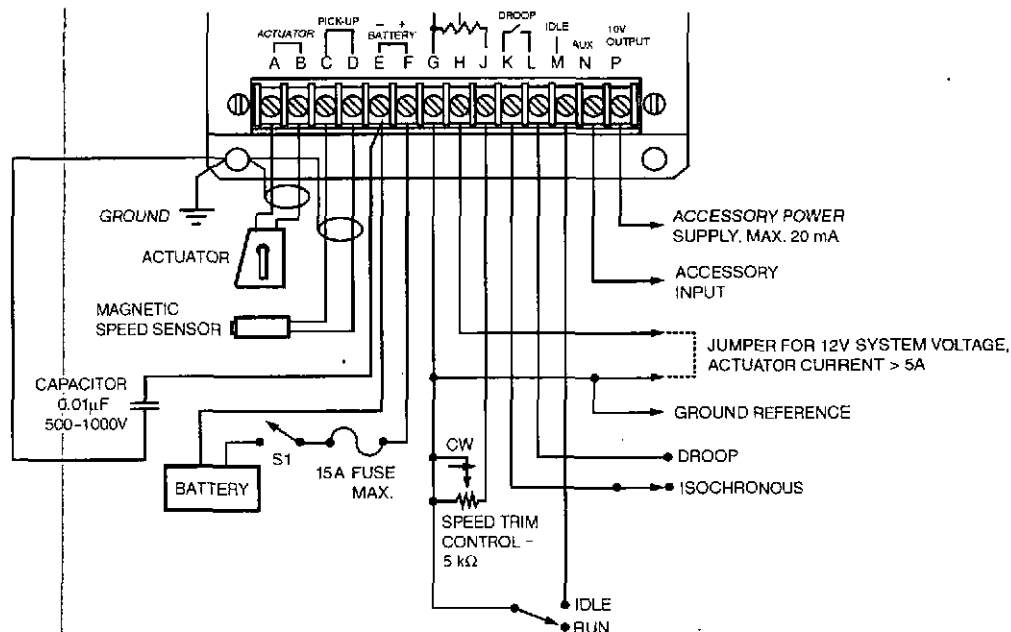

Fig. 11

Setting and Adjusting

Basic setting from Volvo Penta

Engines with electronic speed control delivered from Volvo Penta have their idling speed set at approx. 1100–1300 rpm (jumper between "G" and "M" on the control unit).

Engines for 1500 rpm operation have their operating speed set to approx. 1567 rpm (no jumper between "G" and "M"). Droop approx. 4.5% with jumper between "K" and "L".

Engines for 1800 rpm operation have their operating speed set to approx. 1870 rpm and the droop to approx. 4.5%.

The correct power output is set during the engine's test run on the dynamometer. Thereafter, the governors are sealed by Volvo Penta (ACB275 and ACD175-24).

The control unit that is delivered and to be fitted to the engine, is used for the testing and adjusting. The box with the control unit is then marked by Volvo Penta with both the order No. and engine No.

Therefore, it is important that control units are not mixed when several engines are delivered at the same time.

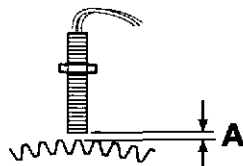

Fig. 12. Engine speed pickup's position in the flywheel housing

A. Distance 0.7–1.0 mm (0.028–0.039")

Speed sender (pickup)

Screw in the pickup (with the engine stopped) until the top of the pickup touches the top of a tooth on the ring gear. Then screw the pickup out 3/4 turn and tighten the lock nut.

Connect the pickup to the control unit according to the wiring diagram (fig 8).

The voltage level of the pulses from the pickup should be at least 1V and max. 30V (AC RMS). The engine will stop if there is no signal.

Terminal "D" on the control unit is connected to ground. This grounds one side of the pickup internally.

The wires between the pickup and control unit must be shielded for their entire length. The shield must be connected to housing on the control unit.

Note! The shield should only be grounded at the control unit. Never ground at the pickup!

Crank the engine using the starter motor and check the voltage level from the pickup. The signal should be min. 1V (AC RMS).

Adjusting the actuator

Actuator ACB275

NOTE! When replacing the ACB275 actuator, the seal must be broken.

This involves some work on the injection equipment which can change the settings. The work must therefore be carried out by specially trained mechanics who have access to the necessary tools and test equipment.

All engine warranties are void if the seal should be broken by unauthorised personnel.

1. Remove the cover from the actuator (pos. 2, fig. 7).
2. **Basic setting:** Adjust linkage length so that when fastened to the operating lever the control rod is approx. 0.5–1.0 mm (0.020–0.039") away from its extreme stop position.

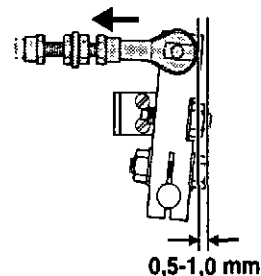

3. **Fine setting:** Connect ammeter and voltmeter according to fig. 13, and check the values according to table in fig. 13.

For the optimum function of the actuator, approx. half the actuator angle should be used. Adjust the link arm's length so that the values stated below are obtained both without load and with full load.

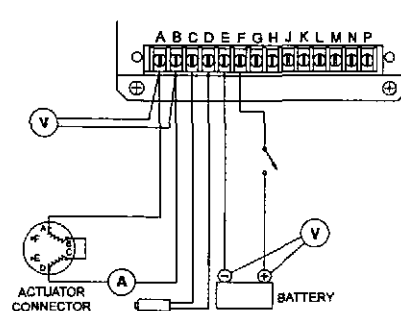

Load	Voltage A – B		Actuator current Amps		Battery Voltage E – F
	recorded	recommended	recorded	recommended	
No load	6.5 – 8.5	1.2 – 1.6	Nominal 24V
Full load	12 – 14	2.4 – 2.8

Fig. 13. Connecting the ammeter and voltmeter for fine adjustment of the actuator.

4. Adjust the fuel setting and seal the actuator.

Actuator ACB225

Max. angle travel of the actuator's lever is 25°.

1. **Basic setting:** Adjust the length of the link arm between the actuator and the injection pump's speed control lever.

The distance between the actuator flap and its stop should be approx. 10 mm (3/8") (A, fig 14).

2. **Fine setting:** Use the same method/values as for the ACB275 actuator. See point 3 in the previous section.

Check that the actuator does not go to its end position at full output.

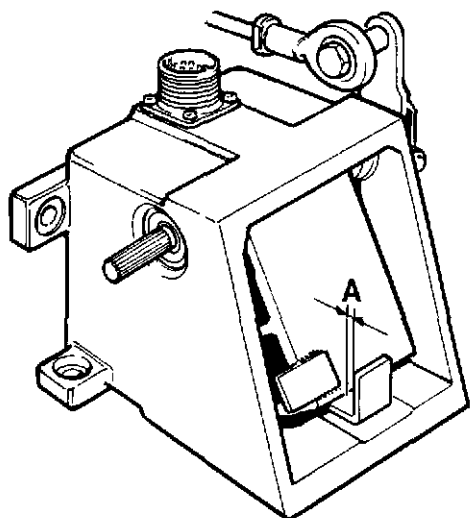

Fig. 14. Actuator ACB225

Basic setting

A = 10 mm (3/8")

Actuator ACD175-24

NOTE! The actuator is only available for 24V system voltage.

The actuator lever has a maximum fuel adjustment set screw (6). This screw is intended to restrict the pumps control rod travel.

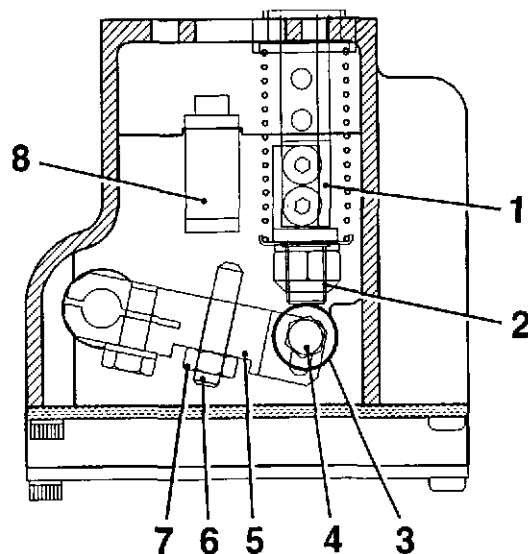

Fig. 15. Actuator ACD175-24

- | | |
|---------------------------|-----------------------------|
| 1. Control rod | 5. Actuator lever |
| 2. Control rod connector | 6. Max. fuel adj. set screw |
| 3. Bearing | 7. Lock nut |
| 4. Bearing mounting screw | 8. Max. fuel stop |

Before the first start

Check the following before connecting the batteries:

1. That the system voltage is correct (12V or 24V).
2. That the polarity is correct at the "E" (minus) terminal on the control unit, and the "F" terminal (plus).

NOTE! The control unit has several built-in protections. Any possible short-circuiting of the actuator or the wires will stop the engine. After the batteries have been disconnected and the cause remedied, the unit will work correctly again.

Provided that a fast fuse is used in the battery cable as shown in the wiring diagrams fig. 8 and fig. 11, reversed polarity will not ruin the control unit. However, other incorrect connections can cause the control unit to be ruined.

3. That the wiring is otherwise correct. See wiring diagrams figs 8, 9, 10 and 11.
4. Set the potentiometers "GAIN" and "STABILITY" in the control unit to the center position.
5. Temporarily connect terminals "G" and "M" on the control unit to get low idle (approx. 600–800 rpm).

First start

1. Connect the batteries and start the engine. The governor should keep the engine at idle. If desired, the idle speed can be increased by turning the "IDLE" potentiometer clockwise. Note, this is a **single turn potentiometer**. Turn carefully and **not** to its end position.

⚠ Warning! Long periods of running at critical speeds can damage flexible couplings, the engine or the generator.

2. After the engine has been checked and its function is normal, remove the jumper between the "G" and "M" terminals on the control unit. The speed will increase to approx. 1567 rpm or 1870 rpm depending on the operating speed ordered.

For new, or previously adjusted control units, the "SPEED" potentiometer should be turned approx. 12 turns clockwise from its end position for an engine speed of 1500 rpm to be obtained.

3. Perform a final adjustment of the "GAIN" and "STABILITY" in the control unit as follows:
 - Run the engine without load and turn the "GAIN" control **clockwise** until instability occurs. Then turn back the control until stability is obtained and then an additional 1/8 turn.
 - Adjust the "STABILITY" control in the same way as for the gain above. See also fig 17.

NOTE! When adjusting the sensitivity "GAIN", the set speed may be changed. Adjust, if necessary, using the "SPEED" potentiometer.

After these adjustments have been completed, load can be applied. It may be necessary to repeat the previous adjustments. Normally, there is a critical point for these adjustments with an unloaded, cold engine.

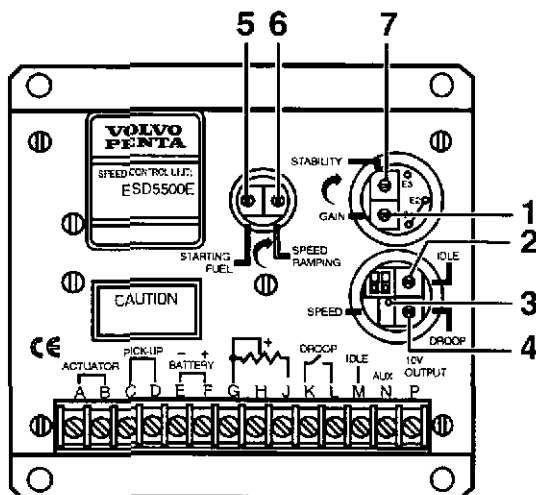

Fig. 16. The Control unit

1. Sensitivity setting ("GAIN")
2. Idle speed control ("IDLE")
3. Operating speed setting ("SPEED")
4. Droop control ("DROOP")
5. Starting fuel adjustment ("STARTING FUEL")
6. Speed ramping adjustment ("SPEED RAMPING")
7. Stability control ("STABILITY")

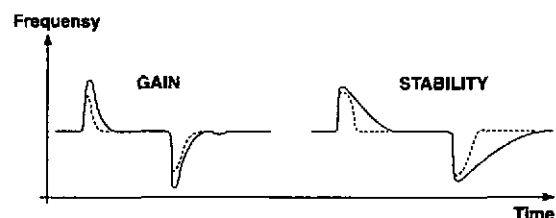
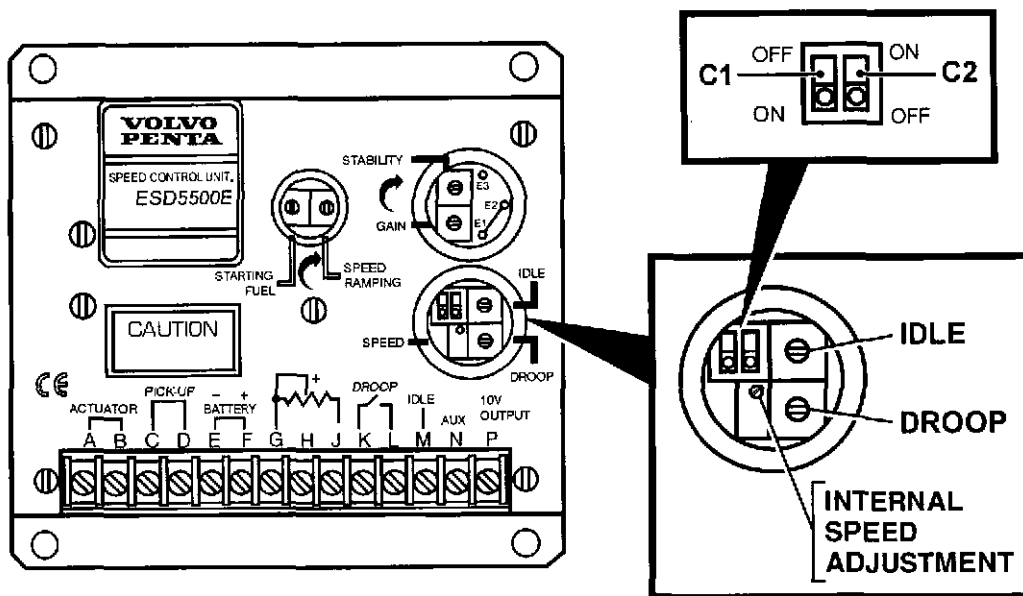

Fig 17. Stabilising process
Dashed line = Best setting



Setting the dip switches C1 and C2:

The **left hand switch** (C1) replaces and functions as the jumper E6 to E7 found in the older control units. The normal position is ON, corresponding the jumper in position on the older units. Move the switch to the OFF position if there is fast instability in the system.

The **right hand switch** (C2) controls an additional circuit affecting the sensitivity of the control unit. With the switch in the ON position the sensitivity is being reduced. This function has been added in order to eliminate fast erratic engine behaviour which can be caused by a very soft or worn coupling in the power train between engine and driven object.

Note: Basic setting of switch C1 is in the ON position, and of switch C2 is in the OFF position. With the switches in these positions the ESD5500E operates exactly like an ESD 5131 or ESD5111.

Parallel Operation

For good load sharing when two or more generators are used in parallel operation, there are two suitable methods.

1. As the electronic governor system works very exact and fast, its advantages can be used for parallel operation by using a load sharing system. If more information is required, contact Volvo Penta.
2. The simplest method for load sharing is to use droop as used by mechanical governors.

For 4.5% droop at 1500 rpm (adjusted by Volvo Penta), terminals "K" and "L" on the control unit should be connected.

To run two engines together in parallel it must be possible to adjust the engine speed. A external speed trim potentiometer connected between terminals "G" and "J" on the control unit gives this possibility (fig 8, pos. 4).

Note. A 5 k Ω /2W potentiometer will give an adjustment range of ± 200 rpm.

Before the generators are connected for parallel operation, each generator should be tested individually. This is done so that the droop is the same (4.5%) for all the connected generators.

The droop method is working well when two generators are run in parallel. The settings become more difficult when more generators are used.

If three or more generators are to be run in parallel, or when there are very high demands (e.g. operation of a radar or telecommunication plants) the method as described under point 1. should be considered.

Fault-tracing

1. Engine will not start

A. Battery voltage

Check the battery voltage at terminals "E" (-) and "F" (+) on the control unit.

Lowest permissible voltages at starter motor speed are:

- 8V DC for 12V system voltage.
- 17V DC for 24V system voltage.

Check that the fuse (fast) pos. 5, fig 8 is intact.

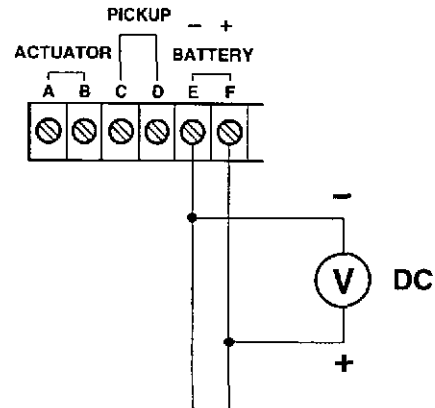

B. The actuator.

Break the power supply to the control unit. Loosen the angled connector on the actuator and check the actuator by measuring the resistance between the different connections using an ohmmeter. Move the governor flap backwards and forwards and note the ohmmeter readings.

If the actuator is working properly, the following values should be obtained:

	ACB225, ACB275	ACD175
Between connections: A - B:	3 ± 1 ohms*	-
C - D:	3 ± 1 ohms*	-
G - H:	-	7 ± 1 ohms*
A - C:	Infinity	-
A - actuator casing:	Infinity	
C - actuator casing:	Infinity	

*Note. At +25°C (77°F).

Fit the angled connector to the actuator and connect the power supply to the control unit.

Disconnect the wire from terminal "A" on the control unit and instead temporarily connect an ammeter in series between the wire and terminal "F". The actuator should then audibly move the control rod to the full fuel position. If necessary, remove the cover from the actuator to check the movement. Read off the ammeter. The current should be approx. 4A (12V) or 2.5A (for 24V system voltage).

NOTE! To remove the cover from the actuator, the seal must be broken. This may only be done by authorized service personnel (ACB275 and ACD175-24 only).

All engine warranties are void if the seal should be broken by unauthorized personnel

If the actuator moves slowly despite the current being at the correct value (approx. 4A) the reason for this must be investigated (possibly it is the control rod in the injection pump sticking).

Check the wiring connections if the actuator does not move at all. If the connections are correct but the actuator still does not move, then replace the actuator.

ACB225, ACB275

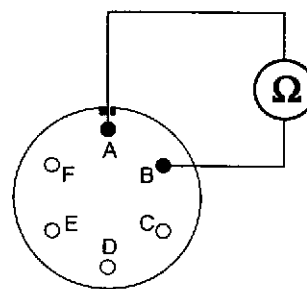

ACD175-24

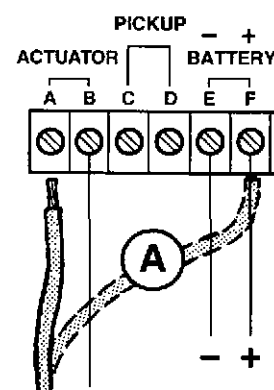
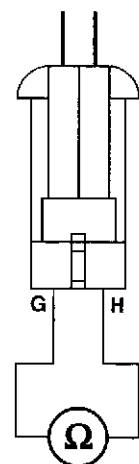

C. The pickup

Connect a voltmeter between terminals "C" and "D" on the control unit. Crank the engine using the starter motor and read off the voltage. It should be min. 1.0V (AC. RMS).

If there is no voltage: Disconnect the wires to terminals "C" and "D" and crank the engine again. If voltage is measured from the pickup then the control unit is faulty.

If there is still no signal from the pickup: Measure the resistance across terminals "C" and "D" on the control unit. The resistance should be between 50 and 250 Ohms. Otherwise, check the wiring and connections. If these are correct then the distance between the pickup and the flywheel ring gear must be checked. The distance should be 0.6–1.0 mm (0.024–0.039") (3/4 turn from the bottom position).

A reduction in distance will give a stronger signal (higher voltage) from the pickup.

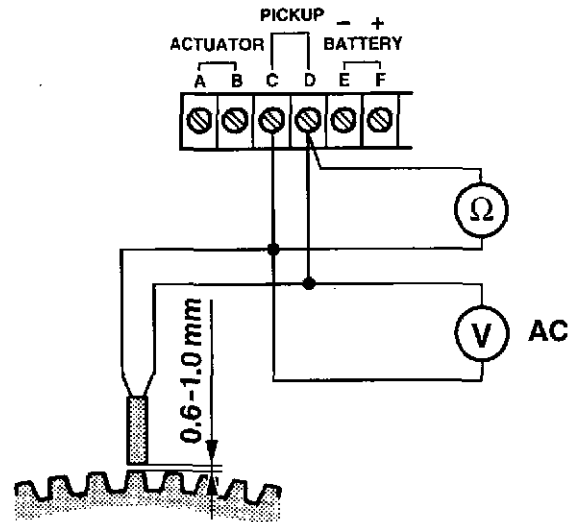

D. The control unit

1. Check the basic setting.
2. Check the voltage between terminals "G" (-) and "P" (+) on the control unit using a voltmeter. **Check the meter's polarity.**

The correct value is 10V DC (applies to engines with both 12V and 24V system voltage).

An incorrect value can be caused by a short-circuit at terminal "P" or a faulty "SPEED" potentiometer.

3. Connect a voltmeter between terminal "A" (-) and "F" (+) on the control unit. **Check the meter's polarity.**

Crank the engine using the starter motor and with the stop solenoid engaged. Check the voltmeter. The correct value is 1.5–2.5V DC (applies to engines with both 12V and 24V system voltages).

An incorrect value can be caused by:

- "SPEED" potentiometer set too low.
- Wiring incorrect to the actuator.
- "SPEED" potentiometer faulty.

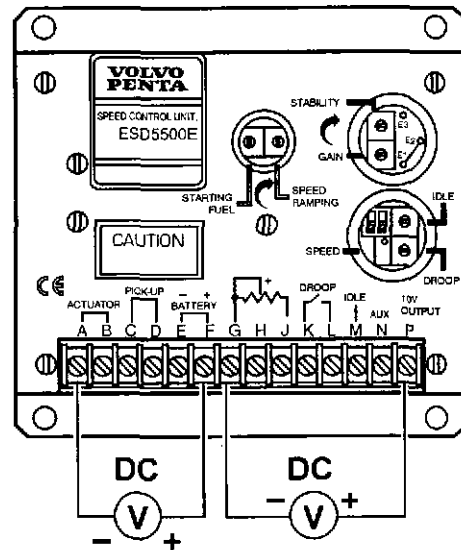

2. Engine overspeeds

Note! Do not crank the engine.

1. Connect the power supply to the control unit. The actuator moves the fuel control rod forward to max. fuel position.
2. Measure the voltage between terminals "A"(-) and "F"(+) on the control unit according to point 3, previous section.

If the voltage is 1.0–2.0V DC, then the:

- "SPEED" adjustment is set too high.
- Control Unit is faulty.

If the voltage is above 2.0V DC, then the:

- Friction is too high in the actuator or in the linkage system.

If the voltage is below 1.0V DC, then the:

- Control unit is faulty.

Note. The above values apply to engines with both 12V and 24V system voltages.

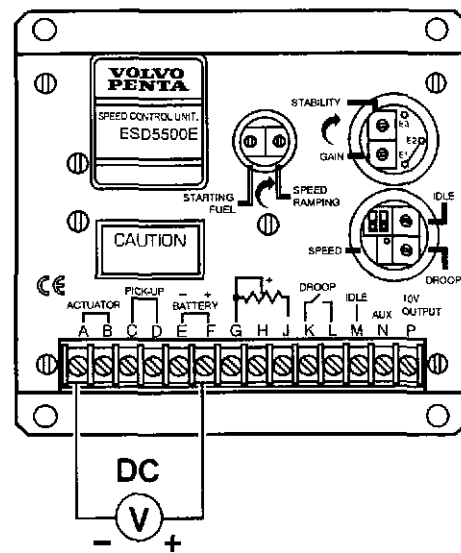

3. Disconnect the wires from the pickup at terminals "C" and "D" on the control unit.
 - If the actuator is still in the max. fuel position, then the control unit is faulty.
 - If the actuator is in the min. fuel quantity position, then the engine speed signal is incorrect. Check the wiring between the pickup and the control unit, and also the shield.

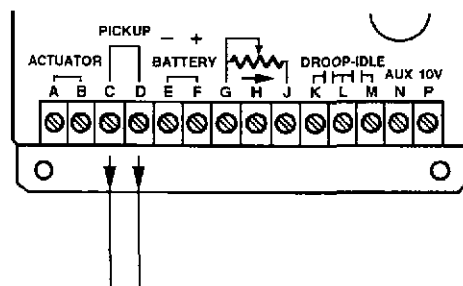

3. Engine does not reach required speed

1. Measure the voltage at the starting battery cables when the engine is cranked using the starter motor. The battery voltage must not be lower than 8V DC for a 12V system or 17V DC for a 24V system.
 - Charge/replace the batteries if the battery voltage is too low. Make sure that the batteries are not underdimensioned.
 - Incorrect wiring to the actuator.
2. Temporary connect a jumper between terminals "A" and "F" on the control unit. The actuator should then go forward to the max. fuel position. If it does not, then the cause is probably one of the following:
 - Incorrect wiring to the control unit from the batteries or from the actuator.
 - Actuator or linkage arms are sticking.
 - Faulty actuator.
3. Measure the actuator voltage between terminals "A" and "B" on the control unit at the engine speed reached.

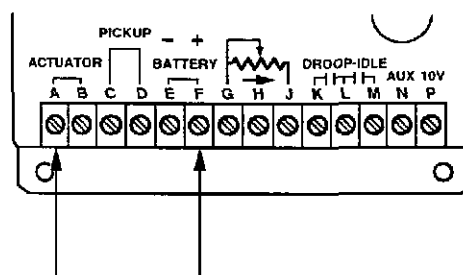

If the voltage is within 2V below the battery voltage, then the fault is probably due to a sticking control rod, incorrect "overspeed springs" (applies to RQ governors), or a sticking linkage rod between the actuator and the injection pump.

If the fault persists after all the above points have been checked and everything appears to be in order, then try adjusting the "SPEED" potentiometer.

4. Electrical interference and undesired droop

If there is equipment installed nearby which emits radio frequency interference (RFI) e.g. electromagnets, semi-conductor type ignition systems, battery chargers or other electrical governors, then this can cause unstable control or undesired droop to be noticed. The control unit has built-in filters which provide some protection against this. High levels of interference must however be treated separately. The sources of interference must be isolated. Also, the wiring to the control unit must be routed as far as possible away from these sources of interference.

The wiring between the pickup and the control unit must be shielded along its entire length. Note that the shield should **only** be connected to the ground terminal on the control unit, and **never** at the pickup (see special wiring for EMC compliance, page 12).

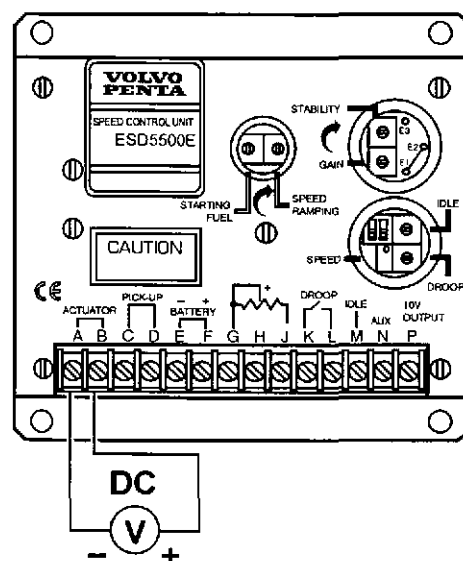

4. Hunting or unstable control

Hunting and unstable control are two problems which require special attention. If they should occur there could be many different, possible reasons of the problems.

If the system does not work satisfactory despite fault-tracing has been done as per sections 1–3, then contact the nearest GAC representative or Volvo Penta.

To provide fault-tracing assistance, the following questions must be answered:

1. What is the approximate frequency of the instability (slow or fast)?
2. What are the positions of the "GAIN" and "STABILITY" potentiometers in the control unit?
3. Does the instability frequency increase when the "GAIN" potentiometer is turned clockwise?
4. Does the instability disappear if the engine speed is temporarily increased or decreased?
5. Does the instability increase or decrease when the engine is loaded?
6. What happens if the jumper "A" between E1 and E2 on the control unit is cut?
7. What happens if an additional capacitor ("B"), value 10 μF , is connected between terminals E2 and E3 according to the figure? **NOTE! E3 is plus (+).**
8. Does the complete governor system, including the stop lever, linkage rod and control rod, move freely without the slightest sign of sticking?
9. Has the actuator current been measured from zero load to full load according to the figure?
10. Positions of "C1" and "C2" switches (ON or OFF)?

Depending on the answers to the above questions, the instability can be caused by:

1. "GAIN" and/or "STABILITY" potentiometers adjusted too high.
2. Too high sensitivity in the control unit in relation to the mass and inertia of the driven units.
3. If a flexible coupling is fitted, stiffness, clearance or torsional vibrations.
4. The injection pump.
5. The linkage system.
6. The alternator unit's voltage regulator.
7. The signal from the pickup.

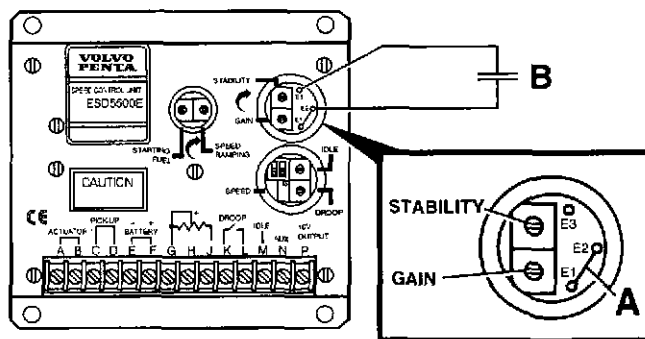

- A. Jumper (connection)
- B. Capacitor (10 μF)

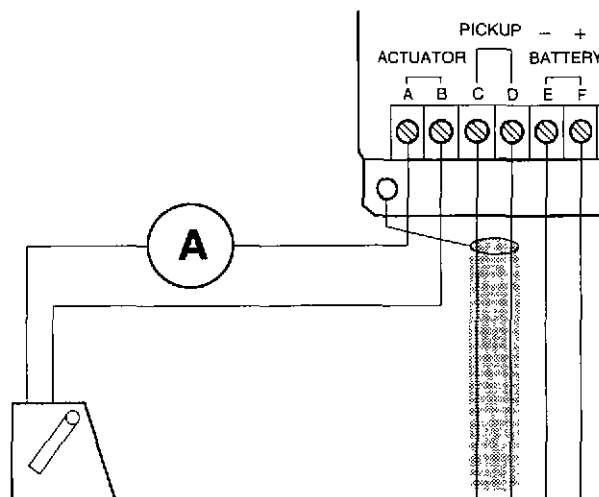

Checking the actuator current

Recordings during testing

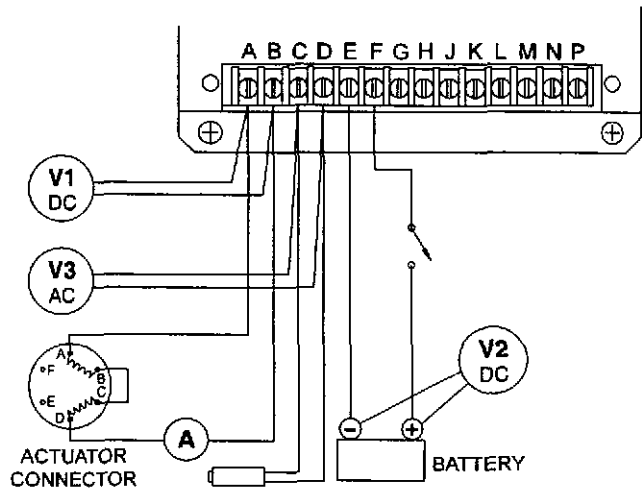

24V (ACB225 and ACB275):

Load	Voltage A – B (V1)		Actuator Current Amps		Battery Voltage (V2)	Voltage (V3)
	recorded	recommended	recorded	recommended	E– F	Speed Sensor
No load	6.5 – 8.5	1.2 – 1.6	Nominal 24 Volt	Starting.....
Full Load	12 – 14	2.4 – 2.8	Nom. Speed....

12V (ACB225 and ACB275):

Load	Voltage A – B (V1)		Actuator Current Amps		Battery Voltage (V2)	Voltage (V3)
	recorded	recommended	recorded	recommended	E– F	Speed Sensor
No load	2.9 – 3.3	2.3 – 2.6	Nominal 12 Volt	Starting.....
Full Load	4.9 – 5.4	3.9 – 4.3	Nom. Speed....

24V (ACD175-24):

Load	Voltage A – B (V1)		Actuator Current Amps		Battery Voltage (V2)	Voltage (V3)
	recorded	recommended	recorded	recommended	E– F	Speed Sensor
No load	6.0 – 9.0	0.9 – 1.3	Nominal 24 Volt	Starting.....
Full Load	10 – 13	1.5 – 1.9	Nom. Speed....

Notes



A series of horizontal dotted lines spanning the width of the page, providing a guide for writing notes. The lines are evenly spaced and extend across the entire width of the page, leaving a small margin on the left side.

Notes

A series of horizontal dotted lines for writing notes, spanning the width of the page.



Report form

Do you have any complaints or other comments about this manual. Please make a copy of this page, write your comments down and send them to us. The address is at the bottom. We would prefer you to write in English or Swedish.

From:

.....
.....
.....

Refers to publication:

Publication No.: Date of issue:

Proposal/motivation:

.....
.....
.....
.....
.....
.....
.....
.....
.....
.....

Date:

Signed:

AB Volvo Penta
Technical Information
Dept. 42200
SE-405 08 Göteborg
Sweden

VOLVO PENTA

AB Volvo Penta

SE-405 08 Göteborg, Sweden

7739757-8 English 12-1999