

# **OPERATOR'S MANUAL**

**TAD1240GE, TAD1241GE, TAD1242GE TWD1240VE**

**(EDC III)**

**VOLVO  
PENTA**

## Foreword

Volvo Penta industrial engines are relied upon throughout the world, in both mobile and stationary applications, under some of the most rigorous conditions imaginable. This is not by chance.

After more than 90 years of producing engines the name Volvo Penta has come to symbolize reliability, technical ingenuity, first-class performance and longevity. We believe that these characteristics are also ultimately your requirements and expectations for new Volvo Penta industrial engines.

**To make certain that your expectations are matched, we ask that you read carefully through the instruction book before starting the engine.**

Sincerely

**AB VOLVO PENTA**



---

### Engine data

Engine designation ..... Product number .....

Serial number .....

Clutch, type/nr. ....

### Nearest Volvo Penta service location

Name ..... Telephone .....

Address .....

# Contents

<b>Safety information</b> .....	2	<b>Maintenance schedule</b> .....	19
Safety instructions for operation and maintenance .....	3	Maintenance schedule .....	19
		Newly rebuilt engine .....	20
<b>Introduction</b> .....	6	<b>Maintenance</b> .....	21
Environmental responsibility .....	6	Engine, general .....	21
Running-in .....	6	Lubrication system .....	25
Fuel and oils .....	6	Lubrication oil .....	26
Maintenance and reserve parts .....	6	Cooling system .....	29
Certified engines .....	7	Coolant, general .....	29
		Fuel system .....	34
<b>Presentation</b> .....	8	Electric system .....	38
Technical description .....	8	Clutch .....	42
EDC III .....	9	<b>Preparation for storage</b> .....	43
Orientation .....	10	Preparation for storage .....	43
		Preparation after storage .....	44
<b>Instrument</b> .....	11	<b>Troubleshooting</b> .....	45
Instrumentbox .....	11	Symptoms and possible causes .....	45
<b>Starting the engine</b> .....	12	<b>Diagnostic function</b> .....	46
Before starting .....	12	Diagnostic function .....	46
Starting procedure EDCIII .....	12	Regarding the diagnostic button's indication blinker .....	46
Instrument box .....	13	Readout of error codes .....	46
Volvo Penta start lock .....	13	Erasing error codes .....	47
Start-up under extreme cold .....	14	Diagnostic trouble codes .....	48
Never use starting fluid .....	15	<b>Technical data</b> .....	54
Start-up with helper batteries .....	15	General .....	54
		Lubrication system .....	54
<b>Operation</b> .....	16	Fuel system .....	55
Checking the instruments .....	16	Cooling system .....	55
Alarms and trouble indicators .....	16	Electric system .....	56
RPM regulation .....	17		
Clutch .....	17		
Low-load operation .....	17		
<b>Shutting down the engine</b> .....	18		
Prior to shut-down .....	18		
Shut-down .....	18		
After shut-down .....	18		
Extra shut-down .....	18		

## CALIFORNIA

### Proposition 65 Warning

Diesel engine exhaust and some of its constituents are known to the State of California to cause cancer, birth defects, and other reproductive harm.

# Safety information

Read this chapter very carefully. It concerns your safety. How safety information is presented in the instruction book and on the product is described here. You will also find an overall picture of the basic safety procedures for operation of the engine.

**Make sure that you have the correct instruction book before reading any further. If you do not, please contact your Volvo Penta dealer.**



Incorrect operation can lead to injuries and/or product or property damage. It is therefore important to read through the instruction book very carefully before you start the engine or perform maintenance or service work. If there is anything that you are unclear on or unsure about even after reading the book, please contact your Volvo Penta dealer for assistance.

 This symbol is used in the instruction book and on the product to let you know that it concerns safety information. Always read this information very carefully.

In the instruction book warning texts are handled according to the following priority system:

 **WARNING!** Warns of risk of injury, extensive damage to the product or other property, or that serious functional problems can occur if the instruction is not followed.

 **IMPORTANT!** Used to call attention to things that can cause damage or functional problems to the product or property.

**NOTE!** Used to call attention to important information that can make the work process or operation go more smoothly.

 This symbol is used in certain cases on our products and refers to important information in the instruction book. Make sure that warning and information symbols on the engine and transmission are always visible and legible. Replace symbols that have been damaged or painted over.

## Safety instructions for operation and maintenance

### Daily checks

Make a habit of always visually checking the engine and engine compartment prior to operation (**before starting the engine**) and after operation (**after shutting down the engine**). This will help you to quickly notice if fuel, coolant or oil leaks or any other abnormal conditions have occurred or are occurring.

### Fuel filling

There is a risk of fire and explosion when filling tanks with fuel. Smoking is forbidden and the engine must be stopped.

Never overfill the tank. Make sure that the cap is correctly closed.

Use only the fuel recommended in the instruction book. Fuel of the wrong grade can cause the engine to run incorrectly or not at all. On a diesel engine it can also lead to seizure of the injection system and over-revving the engine, putting both the machine and nearby people at risk.

### Carbon monoxide poisoning

Only start the engine in a well-ventilated space. During operation in an enclosed space both exhaust and crankcase gases must be properly vented.

### Operation

The engine should not be operated in environments with surrounding explosive substances due to the fact that the electrical and mechanical components can cause sparks.

*Getting close to a running engine is a safety risk.* Hair, fingers, loose-fitting clothing or a dropped tool can get caught in rotating parts causing severe injury.

If the engine has been delivered without protective coverings, all rotating parts and hot surfaces should be covered as necessary following installation to insure personal safety.

### Starting lock

If the instrument panel does not have a key switch the engine compartment should be lockable to prevent unauthorized personnel from starting the engine. A lockable main switch may be used as an alternative.

### Maintenance and service tasks

#### Knowledge

In the instruction book you will find instructions for how the most common maintenance and service tasks can be carried out in a safe and correct manner. Read the instructions carefully before initiating work.

Literature covering more extensive work is available from your Volvo Penta dealer.

Never attempt a procedure if you are not completely certain regarding how it should be performed. Contact your Volvo Penta dealer for assistance.

#### Shut down the engine

*Shut down the engine before opening or removing the engine access panel/hood.* Maintenance and service procedures should be carried out on a stopped engine unless otherwise specified.

Prevent an undesired start-up by removing the starting key and disconnecting the electricity with the main switch and locking it in the disconnected position. A warning notice should also be placed at the operating station advising that work is being carried out.

Working with or getting close to a running engine is a safety risk. Hair, fingers, loose-fitting clothing or a dropped tool can get caught in rotating parts causing severe injury. Volvo Penta recommends that all service work that requires that the engine be running be assigned to an authorized Volvo Penta repair facility.

## Safety instructions for operation and maintenance (cont.)

### Lifting the engine

When lifting the engine use the lifting eyes that are mounted on the engine. Always make sure that the lifting device is in good condition and has sufficient capacity for the lift (the weight of the engine as well as all necessary extra equipment). For safe handling the engine should be lifted with an adjustable lifting boom. All chains or cables should run parallel to each other and as possible at right angles to the upper surface of the engine. Note that extra equipment that is mounted on the engine can change its center of gravity. Special lifting equipment may be necessary to insure correct balance and safe handling. Never perform work on a motor that is only hanging in a lifting device.

### Before starting

Replace all protective covers that have been removed prior to starting the engine. Make sure that no tools or other objects have been left near the engine.

An engine with a turbocharger may never be started without the air filter being mounted. The rotating compressor wheel in the turbo can cause severe injuries. There is also a risk that foreign objects can be sucked in causing damage to the machine.

### Fire and explosion

#### Fuel and lubricating oil

All fuels, most lubricating substances and many chemicals are flammable. Always read and follow all instructions listed on the packaging.

Work on the fuel system must be performed on a cold engine. Fuel leakage and spillage onto hot surfaces or electrical components can cause a fire.

Store oil and fuel-soaked rags and other flammable material in a fire-safe manner. Oil-soaked rags can spontaneously ignite under certain conditions.

Never smoke while filling with fuel or lubricating oil, in proximity to the filling station or in the engine compartment.

#### Non-original parts

Components of the fuel and electrical systems on Volvo Penta engines are designed and manufactured to minimize the risk of explosion or fire according to applicable requirements.

Use of non-original parts can result in explosion or fire.

### Batteries

Batteries contain and develop oxyhydrogen gas, especially while charging. Oxyhydrogen gas is easily flammable and very explosive.

Smoking, open fire or sparks must never be allowed near batteries or the battery compartment.

An improper connection of a battery cable or booster cable can cause a spark that can in turn cause the battery to explode.

### Starting fluid

Never use starting spray or other similar substances to help start an engine with air pre-heating (glow plugs/starting coil). This could cause an explosion in the intake tract. This poses a risk of injury.

### Hot surfaces and fluids

A warm engine always creates a risk for burns. Be careful of hot surfaces. For example: exhaust pipes, turbo, oil sump, turbo pressure pipe, heating coil, hot coolant and warm lubricating oil in lines and hoses.

### Chemicals

Most chemicals, for example glycol, rust prevention substances, preserving oils, degreasers, etc. are hazardous to your health. Always read and follow the directions on the packaging.

Certain chemicals, for example preserving oils are flammable and also hazardous if inhaled. Make sure that you have good ventilation and use a protective mask when spraying. Always read and follow the directions on the packaging.

Keep chemicals and other hazardous materials out of reach of children. Bring leftover or used chemicals to an environmental station for destruction.

### Lubrication system

Warm oil can cause burns. Avoid skin contact with warm oil. Make sure that the lubrication system is not pressurized prior to performing service. Never start or operate the engine without the oil filler cap in place due to risk of oil being thrown out.

## Cooling system

Avoid opening the coolant filler cap when the engine is warm. Steam or hot coolant can squirt out causing burns.

If the filler cap, coolant lines, taps or so on must be opened or removed while the motor is warm the filler cap must be opened slowly and carefully so that pressure is released before the cap is completely removed and work is started. Note that the coolant can still be hot and cause burns.

## Fuel system

Always protect your hands when searching for leaks. Streaming pressurized liquids can make their way into body tissues causing serious injuries. There is a risk of blood poisoning.

Always cover the generator if it is placed under the fuel filter. A fuel spill can damage the generator.

## Electrical system

### Disconnect the power

Before servicing the electrical system the engine should be stopped and the electrical power switched off using the main switch/breakers. External power to the engine heater, battery charger or other equipment mounted on the engine must be switched off.

### Batteries

Batteries contain a very strong corrosive electrolyte. Protect your eyes, skin and clothing during charging or other handling of batteries. Always use safety glasses and gloves.

In case of skin contact, wash with soap and large quantities of water. In case of eye contact rinse immediately with large quantities of water and contact a doctor as soon as possible.

## Electric welding

Remove the positive and negative cables from the batteries. Next, remove all connections to the generator.

Always connect the welding clamp to the component to be welded and as close to the place to be welded as possible. The clamp must never be attached to the engine or so that the current can pass through any layers.

**When finished welding:** Always connect all connections to the generator **before** the battery cables are re-connected.

# Introduction

This instruction book has been compiled to give you the best possible use of your Volvo Penta industrial engine. It contains the information you need to operate and take care of the engine in a safe and correct manner. We therefore ask you to read the instruction book carefully and to learn to handle the engine, controls and additional equipment in a safe manner before you start the engine.

**⚠ IMPORTANT!** The instruction book describes the engine and equipment that are sold by Volvo Penta. In certain applications there can be variations of for example controls and instrumentation that concern both appearance and function. In these cases we refer you to the instruction book for the application in question.

## Environmental care

We all want to live in a pure and healthy environment where we can breathe fresh air, see healthy trees, have clean water in our lakes and oceans and where we can enjoy the sunshine without fearing for our health. Unfortunately this is not always the case today but it is a situation that we all must work to preserve and protect.

As an engine manufacturer Volvo Penta has a special responsibility, therefore care for the environment is a core value in our product development. Today Volvo Penta has a broad engine line where large steps have been taken towards reducing exhaust emissions and improving fuel economy, engine noise and so on.

We hope that you will be careful to preserve these qualities. Always follow the advice in the instruction book regarding fuel quality, operation and maintenance so that you can avoid unnecessary damage to the environment. Contact your Volvo Penta dealer if you notice changes such as decreased fuel economy or increased exhaust smoke.

Remember to always bring hazardous waste such as drained oil, coolant, used batteries etc. to an environmental station for destruction.

Through our mutual efforts we can make a valuable contribution to the environment.

## Running-in

**The engine should be "run-in" during the first 10 hours of operation according to the following:** Run the engine as with normal operation. Full-throttle operation should not occur for more than short periods. Do not run the engine for long periods of time at steady RPM during the run-in period.

An increase in the consumption of lubricating oil is normal during the first 100–200 hours of operation. It is therefore important to check the oil level more often than is normally recommended.

When a clutch is mounted it should be inspected more frequently during the first days of operation. Adjustment may be required to compensate for initial wear of the plates.

## Fuel and oils

Only use fuel and oils of a grade matching that recommended in the instruction book (see the chapter on "Maintenance" under the fuel and lubricating system headings). Other grades can cause problems with operation, decreased fuel economy and in the long run even a shortened lifetime of the engine.

Always change the oil, oil and fuel filters according to the prescribed intervals.

## Maintenance and replacement parts

Volvo Penta engines are constructed for maximal dependability and longevity. They are built to survive in demanding environments but also to have the minimum possible impact on the environment within which they operate. Regular maintenance and use of Volvo Penta original parts will preserve these properties.

Volvo Penta has a worldwide network of authorized dealers. They are specialists on Volvo Penta products and have accessories, original parts, test equipment and the special tools that are necessary for high-quality service and repair work.

**Always adhere to the maintenance schedules listed in the instruction book and remember to provide the engine/transmission identification number when ordering service and parts.**

## Certified engines

For those of you who own an emissions-certified engine that is used in an area where exhaust emissions are legally regulated, it is important to recognize the following:

A certification signifies that an engine type has been inspected and approved by the authorities in question. The manufacturer of the engine guarantees that all engines of the same type will match the engine that was certified.

**This places the following special requirements upon the maintenance and service that you perform on your engine:**

- Maintenance and service intervals recommended by Volvo Penta must be followed.
- Only Volvo Penta original parts may be used.
- Service on the injector pumps, pump settings and injectors must always be performed by an authorized Volvo Penta repair facility.

- The engine may not be rebuilt or modified with the exception of accessories and service kits developed by Volvo Penta for the engine.
- No changes may be made to the engine's exhaust or intake air systems.
- No seals may be broken by non-authorized personnel.

In all other cases follow the advice in the instruction book regarding operation, maintenance and service.

**⚠ IMPORTANT!** In cases of neglected or deficient maintenance/service as well as use of non-original parts AB Volvo Penta will no longer be able to assure that the engine meets conditions of certification. Volvo Penta will not settle damages and/or costs associated with such instances.

## Warranty

Your new Volvo Penta industrial engine is covered by a limited warranty according to the conditions and instructions that are contained in the Warranty and Service book.

Note that AB Volvo Penta's responsibility is limited to that which is named in the Warranty and Service book. Read it carefully immediately following delivery. It contains vital information on subjects such as the warranty card, services, and maintenance that is your responsibility as the owner to be aware of, check on and perform. AB Volvo Penta may otherwise completely or partially deny warranty claims.

**Contact your Volvo Penta dealer if you do not have a Warranty and Service book as well as a customer copy of the warranty card.**

# Presentation

TAD1240GE, TAD1241GE, TAD1242GE and TWD1240VE are inline, direct-injected, 6-cylinder industrial diesel engines.

They are equipped with electronically controlled fuel management, turbochargers, intercoolers and thermostatically regulated cooling systems and electronic RPM regulation.

## Technical description

### Engine and cylinder block

- Cylinder block and cylinder head of alloyed cast iron
- Seven main bearing induction hardened crankshaft
- Wet replaceable cylinder liners
- Cast aluminum pistons with oil cooling
- Three piston rings, the top of which is of the "keystone" variety
- Induction hardened overhead camshaft with roller rocker arms
- Four valves per cylinder
- Replaceable valve seats and valve guides

### Fuel system

- Microprocessor-based control unit for fuel delivery (EDCIII)\*
- Gear-driven feeder pump

- Centrally placed unit injector with electromagnetically controlled fuel valves
- Fuel filter of spin-on type and a water separating filter

### Lubrication system

- Water-cooled oil cooler
- Gear-driven oil pump
- Full flow and bypass oil filters of spin-on type

### Intake air compression system

- Turbocharger

### Cooling system

- Cooler with expansion tank
- Water-cooled line-type intercooler (TWD)  
Air-cooled intercooler (TAD)

### Electrical system

- 24V electric system with generator (60A) with charging sensor

TAD

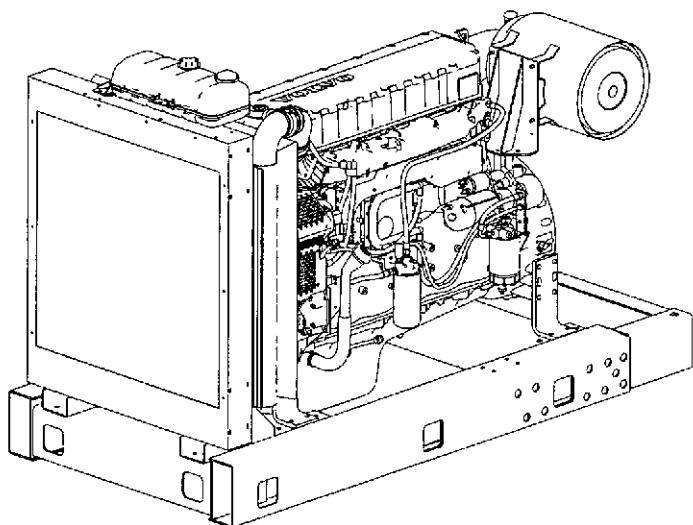

TWD

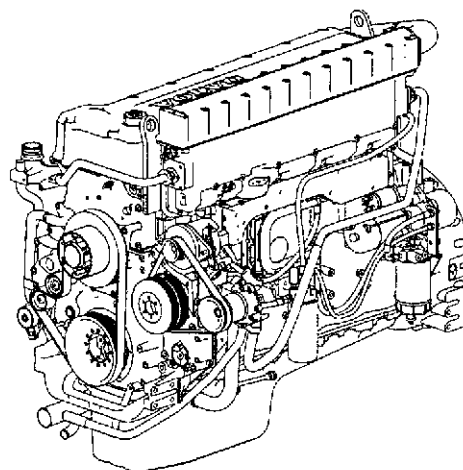

\* EDC III ("Electronic Diesel Control"), see separate description.

## EDC III

EDC III stands for "Electronic Diesel Control" and is an electronic system with CAN (Controller Area Network) communication for diesel engine management. The system was developed by Volvo Penta and includes such parameters as fuel management and diagnostic functions.

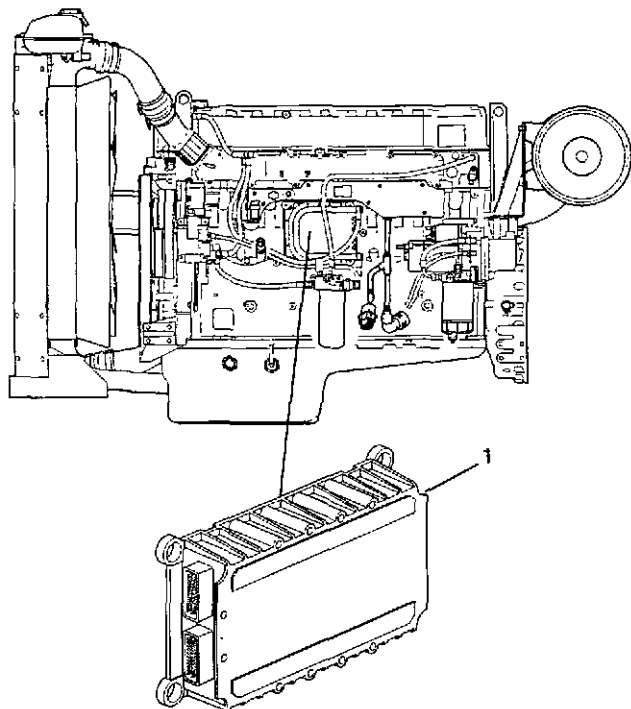

### Control unit (1)

The EDC III system's processor is located in the control unit, protected from moisture and vibrations.

The processor continually receives information regarding:

- RPM levels
- intake boost pressure
- intake temperature
- coolant temperature
- oil pressure
- oil temperature
- fuel alarm, includes both "water in fuel" as well as "fuel pressure"
- coolant level

The information provides a precise overview of current operational conditions making it possible for the processor to do such things as determine the correct fuel dosage and check on the engine's condition.

### Fuel management

The fuel needs of the engine are analyzed up to 50 times per second. Fuel injection quantity and timing are controlled electronically via fuel valves in the unit injectors.

This means that the engine always receives the correct amount of fuel under all operating conditions, providing benefits including improved fuel economy and minimized exhaust emissions.

### Diagnostic function

The diagnostic system's function is to detect and localize disturbances within the EDCIII system, to protect the engine as well as to insure the ability to control the engine during serious disturbances.

If a disturbance is detected a diagnostic indicator in the control panel will begin to blink. Pushing the diagnosis button will provide the operator with an error code to assist in locating the problem.

## Orientation

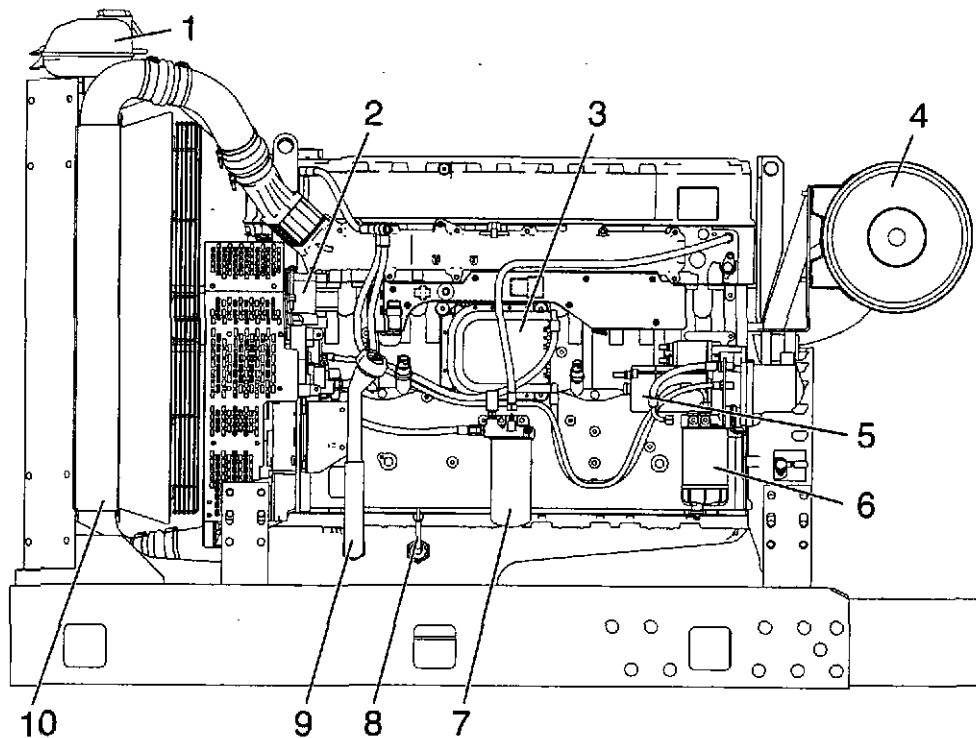

The picture shows TAD1240GE, TAD1241GE and TAD1242GE variants.

1. Expansion tank
2. AC generator
3. Control unit, EMS
4. Air filter
5. Starter motor
6. Fuel pre-filter with water sensor
7. Fuel filter with fuel pressure sensor
8. Oil dipstick
9. Oil filler
10. Intercooler (TAD only)

# Instrument

## Instrumentbox

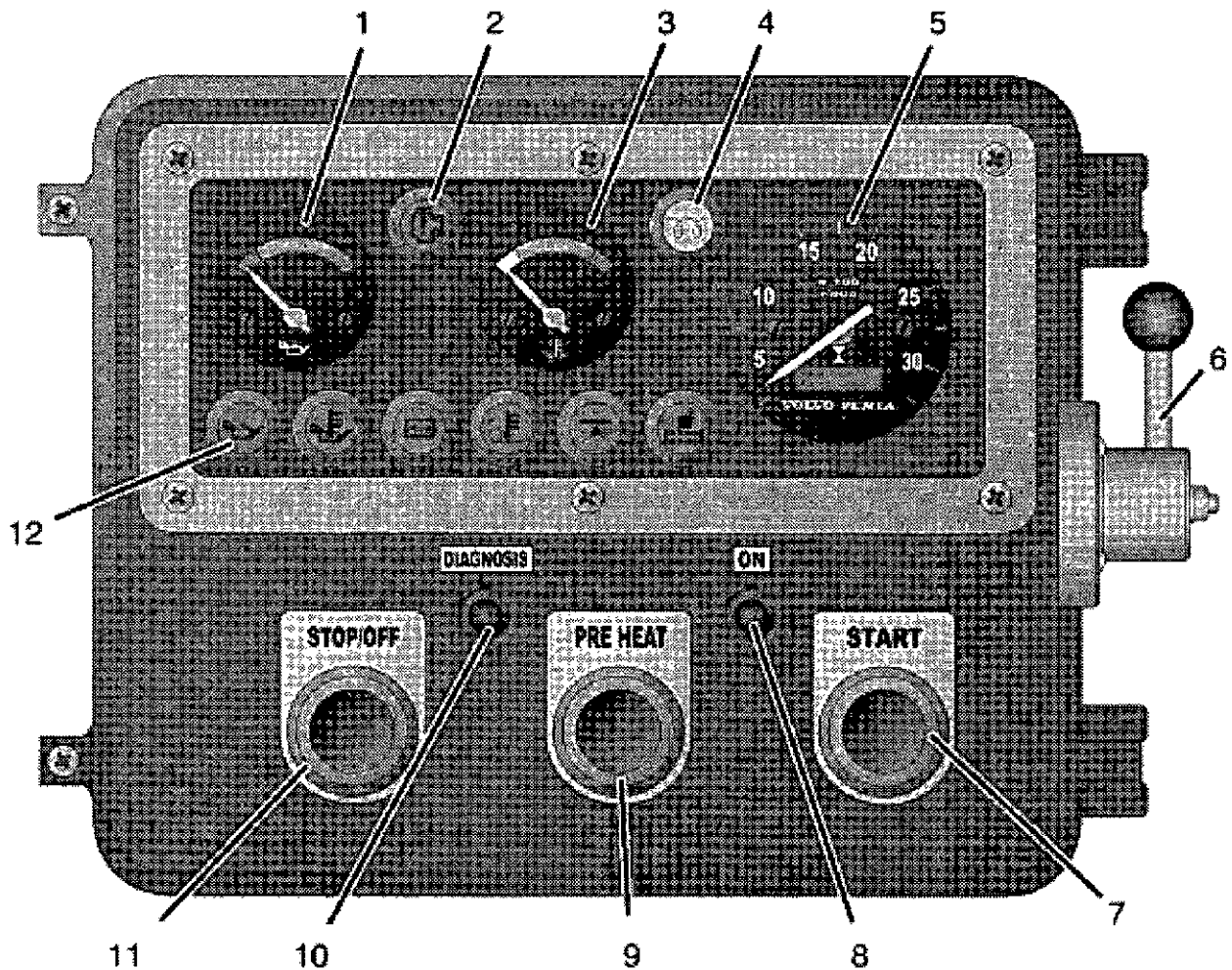

1. Engine oil pressure.
2. Diagnosis lamps. The error codes are read from the diagnosis lamp.
3. Coolant temperature.
4. Indicator lamps Pre-heating and after-heating.
5. Tachometer (RPM).
6. Throttle.
7. Start button.
8. ON button. Used to start the system. Sends current to the system only when it is pushed. It must therefore be held down until the main relay is activated. This takes about one second.
9. Pre-heat button. Used to pre-heat the engine prior to start. Pre-heating is automatically adjusted by the system. The system also has after-heating.
10. Diagnosis button. Used to read out error codes. See "Reading out error codes".
11. Stop/Off button.
12. Warning lights (x6) from the left: oil pressure, oil temperature, battery charging, coolant temperature, coolant level, fuel alarm (includes both "water in fuel" as well as "fuel pressure").

# Starting the engine

Make a habit of always visually checking the engine and engine compartment prior to starting the engine. This will help you to quickly notice if any abnormal conditions have occurred or are occurring. Check also to verify that the instruments show normal values after start-up.

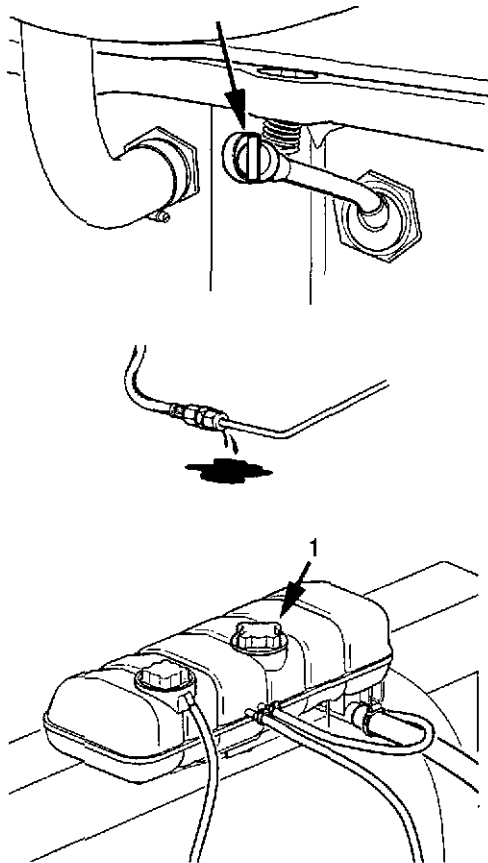

## Before starting

- Check that the oil level is between the MIN and MAX marks. See the chapter "Maintenance, lubrication system".
- Open the petcocks.
- Make sure that there is no leakage of coolant, fuel or oil.
- Check the air filter's pressure drop indicator. See the chapter "Maintenance, Engine, general".
- Check the coolant levels and that the radiator is not blocked on the outside. See the chapter "Maintenance, cooling system".

**⚠ WARNING!** Do not open the coolant filler cap when the engine is warm. Steam or hot coolant can squirt out

- Turn on the main switches.

**⚠ IMPORTANT!** Never switch off the power with the main switch while the engine is running. The generator can be damaged.

- Set the throttle to idle and disengage the clutch/ put the transmission in neutral.

## Start-up procedure EDC III

The throttle must always be in the idle position during start. The EDCIII system makes sure that the engine always receives the correct amount of fuel - **even during cold starts!**

Pre-heating time is set according to engine temperature and can be active for up to 50 seconds both before and after start-up.

The starter motor's activation time is limited to 20 seconds, after which the starter circuit is broken for 80 seconds to prevent the starter motor from overheating.

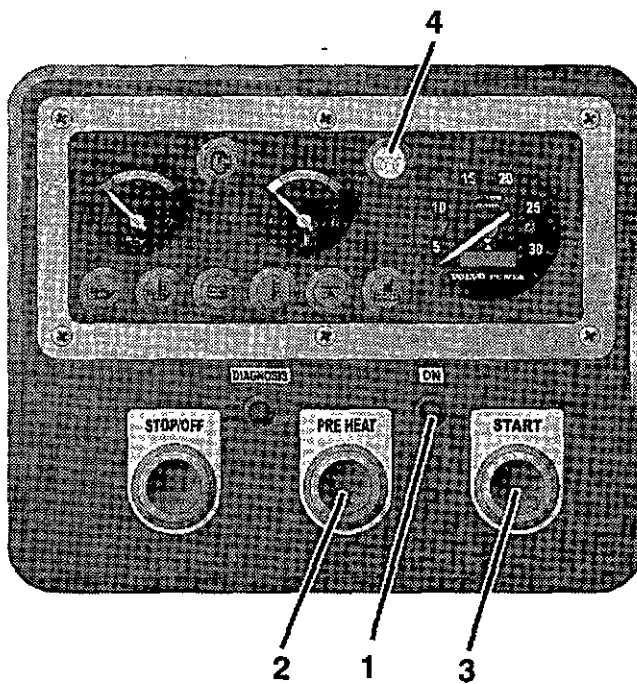

## Instrument box:

### With pre-heating

1. Push in "ON" (1).
2. Push the "Pre-heat" button (2) and wait until the "Pre-heat indicator" (4) goes out.
3. Push the "Start" button (3).

### Without pre-heating

1. Push in "ON" (1).
2. Push the "Start" button (3).
3. Let the engine run at 500–700 RPM for the first 10 seconds.  
Following this, warm up the engine using low RPM and low loading.

**⚠ IMPORTANT!** Never rev-up the engine when it is cold.

## Volvo Penta start lock:

### (Standard setting)

1. Twist the key to the "I" position and check the indicator lamps.
2. Position "II". Pre-heating is activated (pre-heating is an option). Wait until the pre-heating indicator lamp goes out. Pre-heating time is dependent upon engine temperature.
3. Start the engine with position "III". Let the key return to position "I" immediately once the engine has started.

**NOTE!** The engine has a built-in starter motor interlock to prevent inadvertent activation of the starter motor while the engine is running. The key must be twisted to the "O" position before attempting to start again.

Let the engine run at 500–700 RPM for the first 10 seconds. Following this, warm up the engine using low RPM and low loading.

**⚠ IMPORTANT!** Never rev-up the engine when it is cold.

### Alternative pre-heating:

#### (set at time of delivery)

1. Twist the key to the "I" position and check the indicator lamps. Pre-heating activates automatically (pre-heating is an option). Pre-heating time is dependent upon engine temperature.
2. Start the engine with position "III". Let the key return to position "I" immediately once the engine has started.

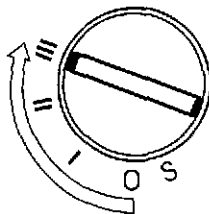

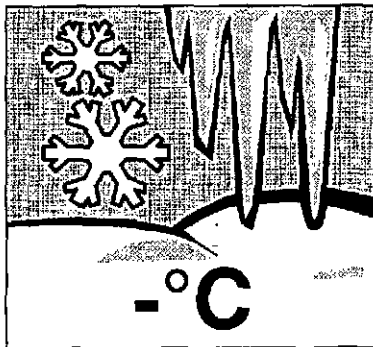

## Start-up under extreme cold

To facilitate and in certain cases allow start-up under extremely cold conditions certain procedures must be followed:

Use a winter fuel (from a well-known supplier) that has been approved for the temperature in question. This minimizes the risk of wax precipitation in the fuel system. During extremely low temperatures use of a fuel heater is recommended.

In order to insure sufficient lubrication we recommend use of synthetic oil of the recommended viscosity for the temperature in question (see chapter "Maintenance, lubrication system"). Synthetic oils retain their lubricating properties over a wider range of temperatures than mineral oils.

Pre-heat the coolant by using a separately mounted electric engine heater. In extreme cases it can be necessary to use a diesel-powered engine heater. Consult your Volvo Penta dealer.

**⚠ IMPORTANT!** Make sure that the cooling system is filled with a glycol mixture. See the chapter "Maintenance, cooling system".

The batteries must be in good condition. Cold reduces the capacity of the batteries. Increasing the total battery capacity may be necessary.



## Never use starting spray

**⚠ WARNING!** Never use starting spray or other similar substances to help start an engine. This could cause an explosion in the intake tract. This poses a risk of injury.

## Start with booster batteries

**⚠ WARNING!** Batteries (especially booster batteries) contain oxyhydrogen gas that is very explosive. A spark, which can occur if the booster batteries are improperly connected, can be sufficient to cause a battery to explode causing damage and/or injury.

1. Make sure that the booster batteries are connected (in series or in parallel) so that the ground voltage corresponds to the engine's system voltage.
2. First connect the red booster cable (+) to the booster battery and then to the dead battery. Then connect the black booster cable (-) to the booster battery, then to a place that is **a distance away from the dead battery**, i.e. next to the main switch on the negative wiring or at the negative cable's connection to the starter motor.
3. Start the engine.

**⚠ WARNING!** Do not disturb the connections while attempting to start the engine (risk for creating sparks) and do not lean over any of the batteries.

4. Remove the cables in reverse order.

**⚠ WARNING!** The normal cables to the standard batteries must absolutely not be modified.

# Operation

Proper operating technique is important both to fuel economy and the engine's useful life. Always allow the engine to reach normal operating temperature before applying maximum power. Avoid sudden throttle changes and high RPM operation.

**⚠ IMPORTANT!** During unmanned operation, if the Volvo Penta instrument box is **not** used, an automatic shut-off should be installed for oil pressure and coolant temperature.

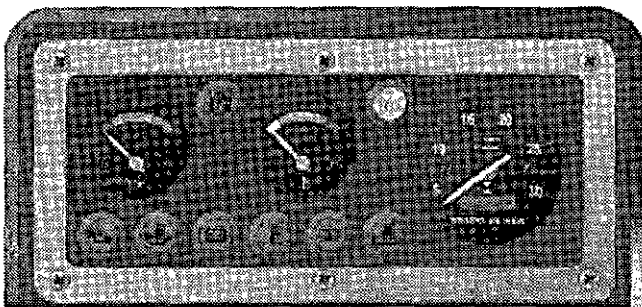

## Check the instruments

Check the instruments directly after start-up and at regular intervals during operation. The indicators should be within the green areas.

**Coolant temperature:** Green zone (75°C-95°C).

**Oil pressure, warm motor:** Green zone. At idle it is normal to have a lower value.

**⚠ IMPORTANT!** For engines under continuous operation lubricating oil levels must be checked at least every **8 hours**. See the chapter "Maintenance, lubrication system".

## Alarms and error indications

If the EDCIII system receives abnormal signals from the engine the "Diagnostic lamp" (1) will begin to blink. Pushing the "Diagnostic button" (2) will give a error code that can assist in locating the problem. Additional information on error codes and location of problems is in the chapter "Problem location".

**The following conditions apply when the Volvo Penta instrument box is used:**

- In case of excessively low oil pressure or excessively high coolant temperature the engine is shut down automatically and the acoustic alarm is activated.
- In case of excessive charge-air temperature and oil temperature the EDCIII system temporarily reduces the engine power until the value in question normalizes. A warning lamp is activated.
- In case of low coolant level, if the engine is equipped with a coolant level sensor the engine is shut down and the acoustic alarm is activated. The warning lamp is activated.
- In case of lack of electrical charging a warning lamp is activated.
- In case of a fuel warning a warning lamp is activated.

**For other applications we refer to the application instruction book in question.**

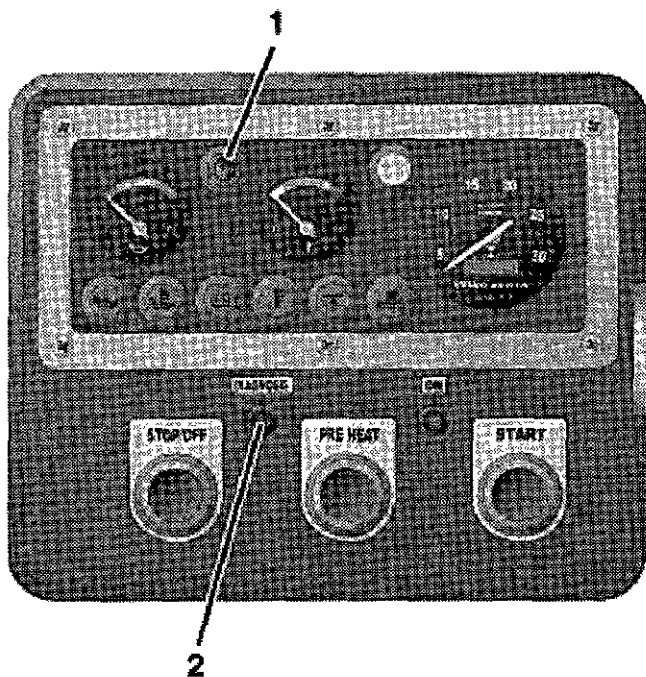

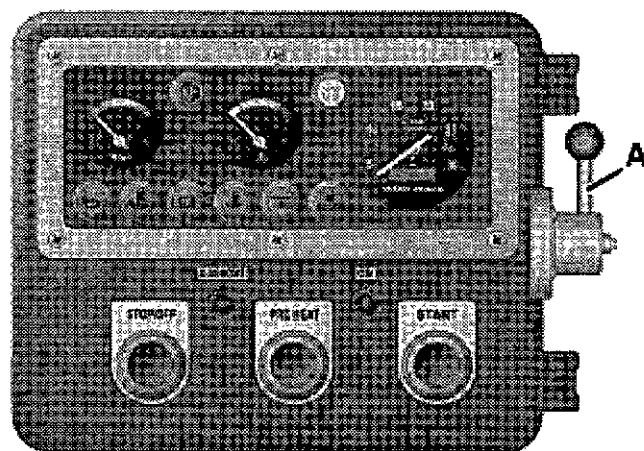

## Throttle

The throttle (A) is mounted on the right side of the instrument box. Avoid sudden and extreme changes in throttle position.

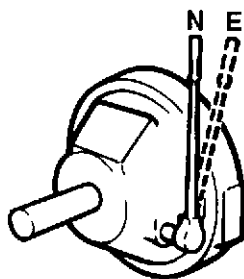

## Clutch

A clutch is optional. Engage the clutch at a **1000–1200 RPM max.**

**N** = Neutral

**E** = Engaged

## Low-load operation

Avoid prolonged operation at idle or at low loading. This can cause increased oil consumption and eventual oil leakage from the exhaust pipe due to oil leaking past the turbocharger seals and following with the charge air into the intake tract during low turbo pressure conditions.

A consequence of this is a build-up of carbon deposits on the valves, tops of the pistons, in the exhaust ports and the exhaust turbo.

Low loads also result in a combustion temperature that is so low that complete combustion of the fuel can not be guaranteed. Possible consequences of this include fuel dilution of the lubrication oil as well as leakage from the exhaust pipe.

**If the following items are performed as a complement to the normal care of the engine there will be no risk of operational disturbances due to operation at low loads:**

- Keep low load operations to a minimum. If periodic test operation of the engine is done without load every week, the operating time should be limited to approximately 5 minutes.
- Operate the engine under full load for approximately 4 hours once a year. Carbon deposits in the engine and exhaust system will thereby have the chance to burn off.

# Stopping the engine

In case of extended time between uses the engine should be run until warm at least once every 14 days. This prevents corrosion of the engine. If the engine will not be used for more than two months preservation should be performed. See the chapter "Storage".

**⚠ IMPORTANT!** In case of freezing temperatures liquid in the cooling system must have sufficient anti-freeze. See the chapter "Maintenance, cooling system". A poorly charged battery can freeze and break.



## Before shut-down

Allow the engine to run a few minutes with no load before it is shut down. This permits an evening out of temperatures within the engine, which prevents "after-boiling" as well as cooling the turbocharger somewhat. This contributes to a lengthened useful life without disruptions.

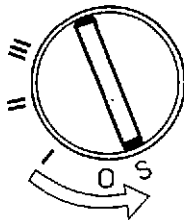
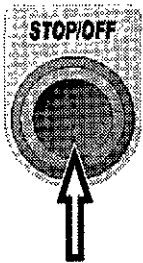

## Stop

- Disengage the clutch/transmission (if possible).
- Push in the stop button.
- The engine stops and the electrical system shuts down after approximately 6 seconds.

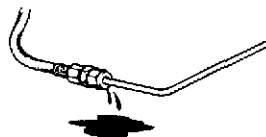

## After shut-down

- Check the engine and the engine compartment with respect to possible leakage.
- Switch off the main switch during extended periods without use.

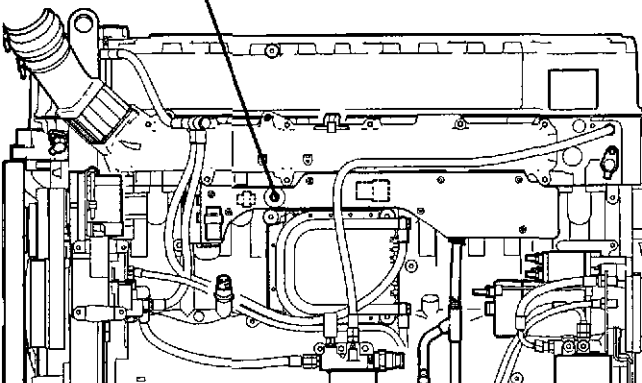

## Extra stop

The extra stop is on the engines left side, above the control unit.

**⚠ WARNING!** Approaching or working on a running engine is a safety risk. Beware of rotating parts and hot surfaces.

# Maintenance schedule

## General

Your Volvo Penta engine and its equipment are built to provide a high degree of reliability and a long useful life. They are built to have the minimum possible effect upon the environment. Preventative maintenance according to the maintenance schedule and use of original Volvo Penta parts will preserve these qualities and help to avoid unnecessary operational disturbances.

## MAINTENANCE SCHEDULE

**⚠ WARNING!** Prior to starting maintenance work the chapter "Maintenance" should be read carefully. In it you will find instructions for how the work can be carried out in a safe and correct manner

**⚠ IMPORTANT!** When both operational and calendar times are given maintenance should be performed in accordance with the first interval to arrive. Maintenance points marked with  should be performed by an authorized Volvo Penta service facility.

### Daily, before the first start-up

- Engine and engine compartment, general inspection ..... page 21
- Air filter indicator, check <sup>1)</sup> ..... page 24
- Oil level, check and add ..... page 26
- Coolant, check level ..... page 30

<sup>1)</sup> Change the air filter at least every 12th month.

### Every 50th operational hour / at least every 12th month

- Fuel filter. Drain water/impurities ..... page 36

### After the first 150 operational hours

- Engine oil, change <sup>1)</sup> ..... page 26

<sup>1)</sup> The oil change is recommended, the new engine oil should be one that is recommended by Volvo Penta

### Every 50–600 operational hours / at least every 12th month

- Engine oil, change <sup>1)</sup> ..... page 26
- Oil filter/Bypass filter, change <sup>2)</sup> ..... page 27

<sup>1)</sup> Oil change intervals will vary depending upon the grade of the oil and the amount of sulfur in the fuel. See page 25.

<sup>2)</sup> The filter must be changed with every oil change.

### Every 400th operational hour / at least every 12th month

- Fuel tank (sludge collector), drain. .... not shown
- Clutch, lubrication<sup>2)</sup> ..... page 42
- Clutch, adjustment<sup>2)</sup> ..... page 42
- Drive belts, check/adjust ..... page 22–23
- Coolant (anti-corrosive mixture), replenishment <sup>1)</sup> ..... page 29
- Batteries, check electrolyte level ..... page 39

<sup>1)</sup> Replenish with 1/2 liter corrosion protection. **IMPORTANT!** This should be done **only** if the cooling system is filled with an anti-corrosive mixture (**not** a glycol mixture).

<sup>2)</sup> Every 200<sup>th</sup> hour.

**Every 800th operational hour / at least every 12th month**

- Charge air pipes, check for leaks ..... page 21
- Fuel pre-filter, change filter element ..... page 36
- Fuel filter, change ..... page 35
- Fuel system, purging ..... page 37
- Fuel pre-filter. Check ..... not shown

**Every 1000 operational hours / at least every 6th month**

- Coolant filter, change <sup>1)</sup> ..... page 33

<sup>1)</sup> Not concurrent with the change of coolant.

**Every 2000 operational hours**

- Turbocharger, check ..... not shown
- Valve play, check/adjust ..... not shown
- Coolant, change (Anti-corrosive liquid) ..... pages 28–31

**Every 12th month**

- EDC system. Check with diagnosis tool ..... not shown
- Engine, general check ..... not shown
- Air filter element, change ..... page 24
- Engine, cleaning/painting ..... not shown
- Air Filter, tank ventilation, change. .... not shown
- Air filter, air compressor, change. .... not shown

**Every 48th month or every 10,000 operational hours**

- Cooling system, check/flush ..... page 30, 32
- Coolant (Glycol mixture), change ..... pages 28–31

**Newly rebuilt engine:**

**After the first 250 hours of operation**

- Valve play, adjust ..... not shown

# Maintenance

This chapter contains general technical information and instructions detailing how the recommended maintenance should be performed. Read carefully through the instructions before starting the task. The time frames for when each maintenance point should be performed are given in the previous chapter: Maintenance schedule.

**⚠ WARNING!** Read through the safety instructions for maintenance and service work in the chapter: Safety information, before starting to work.

**⚠ WARNING!** Maintenance and service work shall be performed on a stopped engine if not otherwise indicated. Stop the engine before the engine cover/hood is opened or removed. Make inadvertent start-up impossible by removing the starting key and disconnect the power using the main switch.

---

## Engine, general

---

### General inspection

Get in the habit of giving the engine and engine compartment a "visual" inspection **before starting the engine** and after operation **when the engine has stopped**. This will help you to quickly realize if something unusual has happened or is happening.

Look especially carefully for oil, fuel and coolant leakage, loose screws, worn or loose drive belts, loose connections or damaged hoses and wires. The inspection only takes a few minutes but can mean that serious service interruptions and costly repairs can be avoided.

**⚠ WARNING!** Puddles of fuel, oil or grease on the engine or in the engine compartment are a fire hazard and must be removed as soon as they are noticed.

**⚠ IMPORTANT!** If leakage of oil, fuel or coolant is detected the cause must be determined and the problem resolved before the engine is started.

**⚠ IMPORTANT!** When cleaning with a high-pressure sprayer the following instructions must be kept in mind: Never point the spray at seals, rubber hoses or electric components. Never use the high-pressure function while cleaning the engine.

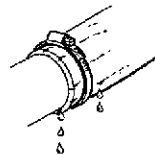
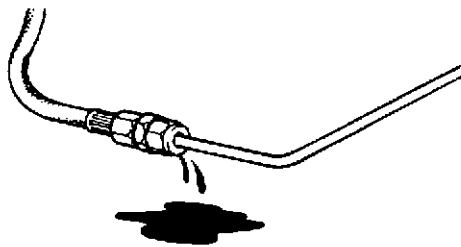

TAD

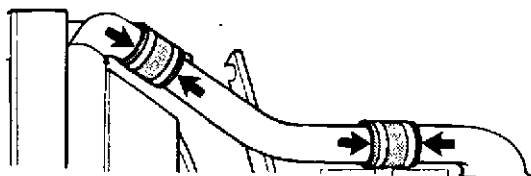

### Charge air pipes, check

Check the condition of the charge air pipes and clamps looking for leaks or other damage. Change as needed.

## Drive belts, check/adjust.

Check and adjustments should be done when the drive belts are warm.

The drive belt to the generator should be able to press in 3-4 mm between the drive belt pulleys.

The drive belt to the generator must be adjusted manually but the other drive belt is automatically adjusted. See "Drive belts, replacing". Check the drive belts for damage and wear. Replace when needed.

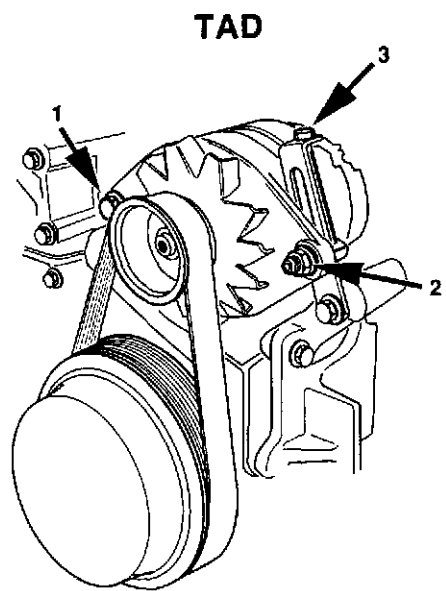

## Generator belt, replacing

1. Switch the main switch/es off and make sure that the engine has no electrical power.
2. Remove the protective grill and the outer fan ring from around the cooling fan.
3. Remove the protective guards from around the drive belts.
4. Loosen the inner retaining screw (1) a couple of turns.
5. Loosen the lock screws (2) so that the tightening screws (3) can turn freely. Loosen the tightening screws and remove the drive belts.

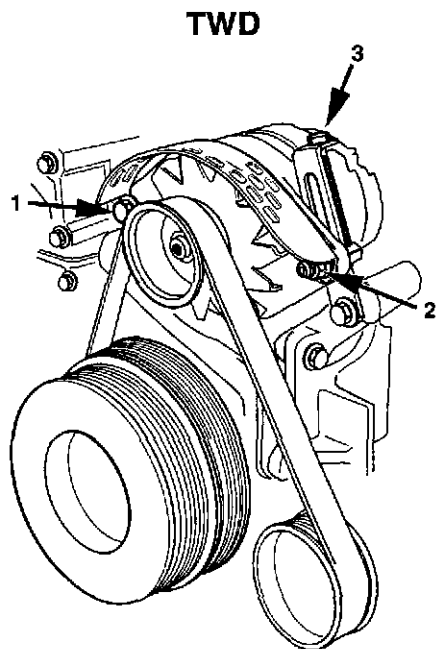

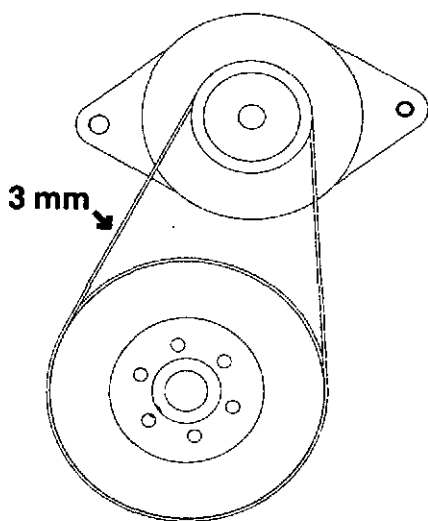

6. Mount the new drive belt and tighten it with the tightening screws (3). The play should be 3 mm for new belts and 3-4 mm for old belts. The play is measured where the drive belts are at their longest between pulleys. Tighten the inner retaining screw (1) and the lock screws (2).

**⚠ IMPORTANT! !** Always change a belt that is worn or damaged.

**NOTE!** When the belt's tensioning mechanism is tightened additional tension is applied to the belt.

7. Replace the protective guards around the drive belts.
8. Replace the protective grill and the outer fan ring around the cooling fan.
8. Start the engine and perform a functional check.

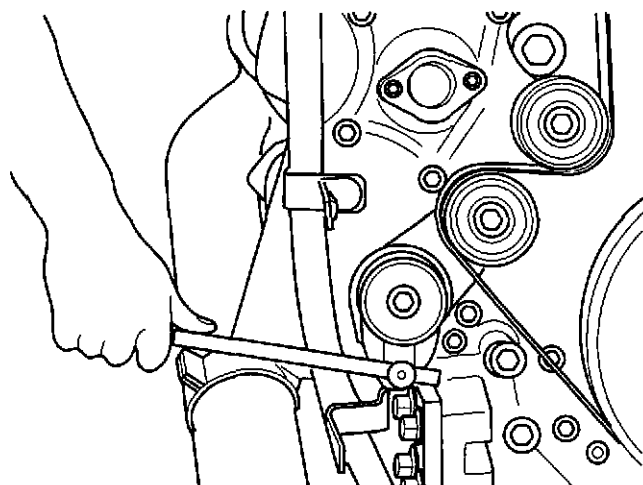

### Drive belt, replacing

1. Switch the main switch/es off and make sure that the engine has no electrical power.
2. Remove the protective grill and the outer fan ring from around the cooling fan.
3. Remove the protective guards from around the drive belts.
4. Place a 1/4" wrench in the belt tensioner. Lift up the wrench and remove the drive belt.
5. Make sure that the pulleys are clean and undamaged.
6. Lift up the 1/4" wrench and mount the new drive belt.
7. Replace the protective guards around the drive belts.
8. Replace the protective grill and the outer fan ring around the cooling fan.
9. Start the engine and perform a functional check.

## Air filter, check/replace

The air filter should be replaced when the indicator remains in the the red field when the engine has stopped. Reset the gauge (1) after replacing the indicator by prssing the button.

**NOTE!** The filter should not be touched before the indicator is in the red. Dispose of the old filter. It may not be cleaned or reused.

**! IMPORTANT!** Under continuous operation the filter should be checked every 8 hours. For operation in extremely dirty environments such as coal mines and stone crushers a special filter is available (not sold by Volvo Penta).

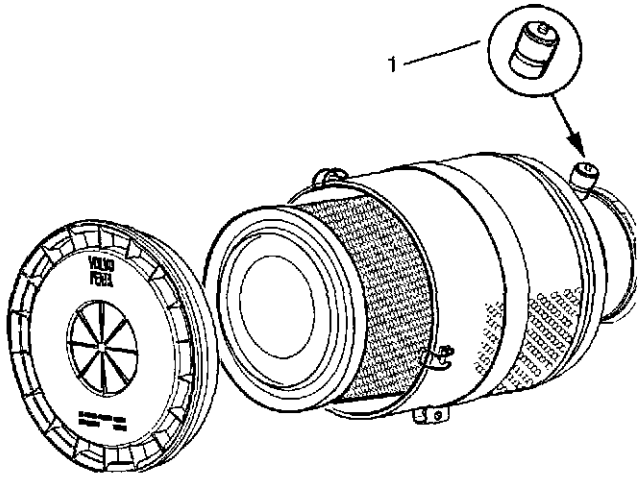

## Lubrication system

Oil change intervals can vary between 50–600 hours depending upon the grade of the oil and the sulfur content of the fuel. **Note that the oil change intervals may never exceed a period of 12 months.**

If change intervals longer than those provided are desired, the condition of the oil must be checked by the manufacturer of the oil by regular testing.

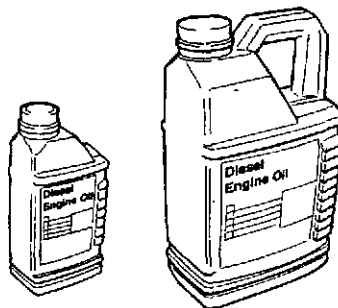

Oil grade	Fuel's sulfur content, percent by weight		
	up to 0.5%	0,5 – 1,0%	more than 1.0% <sup>1)</sup>
Oil change interval: During operation first reached			
VDS-2 and ACEA E3 <sup>2)</sup>	600 hours or 12 months	300 hours or 12 months	150 hours or 12 months
VDS and ACEA E3 <sup>2)</sup>	400 hours or 12 months	200 hours or 12 months	100 hours or 12 months <sup>3)</sup>
ACEA : E4, E3, E2 API: CE, CF, CF-4, CG-4, CH-4	200 hours or 12 months	100 hours or 12 months	50 hours or 12 months <sup>3)</sup>

<sup>1)</sup> If the sulfur content is 1.0% by weight oil with a TBN 15 must be used.

<sup>2)</sup> Lubricating oil must fulfill both requirements.

Note: API: CG-4 or CH-4 are acceptable for markets outside of Europe (instead of ACEA A3).

<sup>3)</sup> Oil with TBN 14–20 must be used

**NOTE!** Mineral-based, as well as completely or partially synthetic oil can be used as long as it satisfies the grade requirements listed above.

VDS = Volvo Drain Specification

ACEA = Association des Constructeurs Européenne d'Automobiles

API = American Petroleum Institute

TBN = Total Base Number

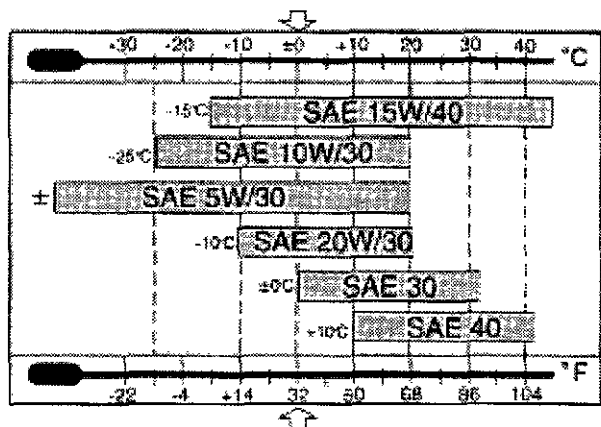

### Viscosity

Viscosity should be chosen using the adjoining table. **Note:** The temperature values refer to steady outside air temperature.

\* Refers to synthetic or partially synthetic oil

### Oil change amount

See chapter "Technical Data".

## Oil level, check and add

The oil level should be within the marked area on the dipstick and should be checked daily before the first start.

Add oil using the filler opening on the side of the engine.

Check that the correct level is reached. Wait a few minutes so that the oil has time to run down into the oil pan.

**⚠ IMPORTANT!** Do not fill over the maximum oil level. Only use oil of the recommended grade (see previous page).

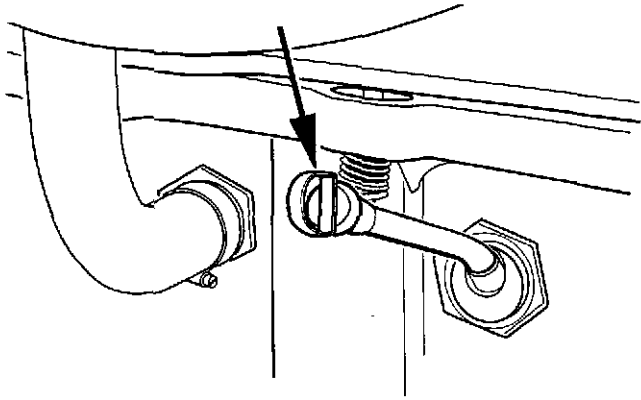

## Engine oil, change

**⚠ WARNING!** Hot oil can cause severe burns.

**NOTE!** Oil should be changed while the engine is warm.

1. Connect the drain hose to the oil bilge pump and make sure that leakage can not occur.
2. Pump out the oil (or remove the drain plug and drain the oil).

**NOTE!** Collect all the used oil and deliver it to a used oil collection facility.

3. Remove the drain hose (or replace the drain plug).
4. Fill with new oil.

The volume of oil including changing three filters for a horizontally installed engine with a standard oil pan is 35 liters.

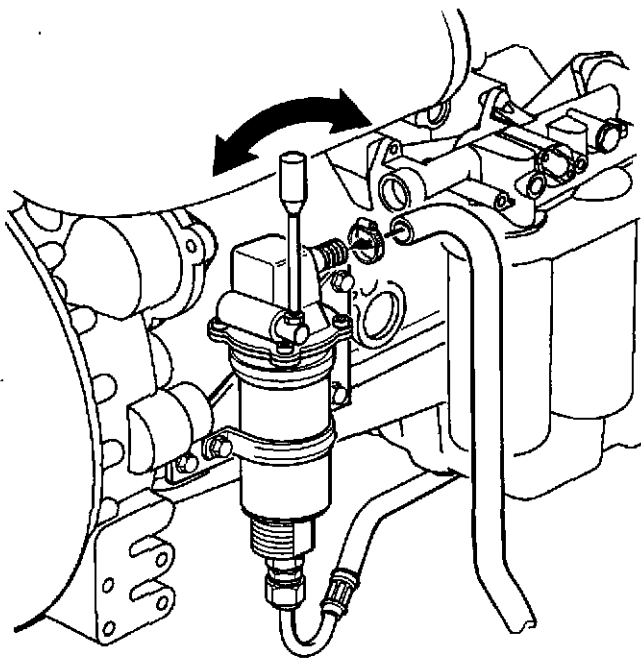

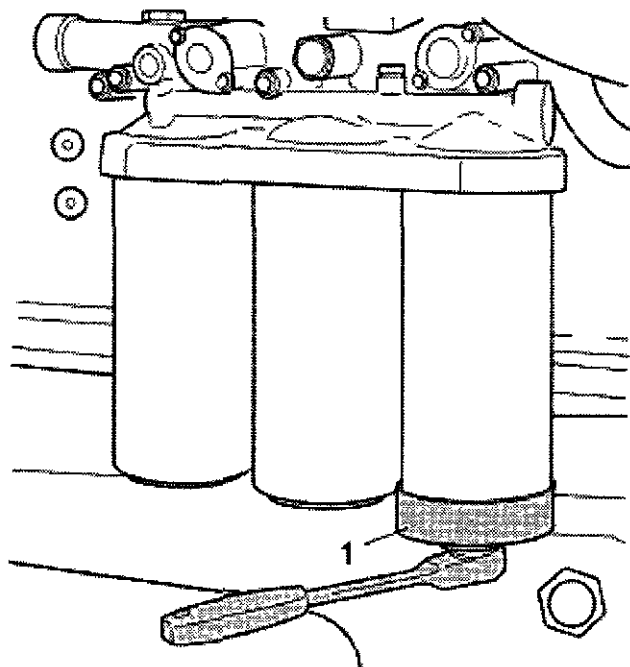

## Oil filter/Bypass filter, change

**⚠ WARNING!** Hot oil can cause severe burns.

1. Clean the oil filter housing.
2. Remove all oil filters using appropriate filter wrenches (1).
3. Clean the sealing surface on the filter housing, making sure that no gasket residue remains.
4. Spread a thin layer of engine oil on the new filter's sealing rings.
5. Install the new oil filter. The two full-flow filters should be tightened  $1/2$  to  $3/4$  turn following seal contact. The bypass filter should be tightened  $3/4$  to 1 turn following seal contact.
6. Fill with oil, start the engine and operate it for 20-30 seconds.
7. Shut off the engine, check the oil level and fill with oil as needed.
8. Check the seals around the oil filters.

## Cooling system

The cooling system should be filled with a coolant that protects the engine from internal corrosion and frost damage where the climate so demands. **Never use water only.**

The anti-corrosion additives become less effective with time, necessitating periodic coolant changes. Assuming that Volvo Penta's recommendations regarding coolant are adhered to the following change intervals apply:

Coolant	Change interval
Volvo Penta coolant (glycol mixture) with coolant filter	Every fourth year or at least every 10,000 operational hours
Volvo Penta corrosion protection	Every year or at least every 2000 operational hours
Coolant filter	Every 6th month or every 1000 operational hours

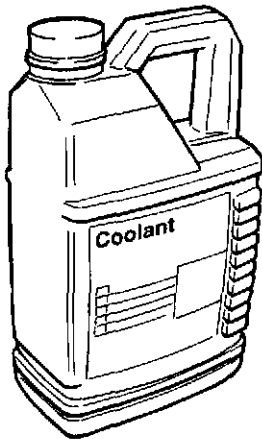

### Coolant, general

The fresh water system should always be filled with a coolant that protects the engine against internal corrosion as well as from freeze damage where the climate so demands.

The anti-corrosion additives become less effective with time, necessitating periodic coolant changes.

**⚠ IMPORTANT!** Never use water only as a coolant. Change the coolant according to the maintenance schedule's recommendations.

### Water quality

To avoid the risk of cooling system blockage coolant must be mixed using **pure** water according to ASTM D4985. In there are any doubts regarding the purity of the water **distilled water** or **pre-mixed coolant** must be used.

#### ASTM D4985:

Total solid particles .....	< 340 ppm
Total hardness .....	< 9.5° dH
Chloride .....	< 40 ppm
Sulfates .....	< 100 ppm
PH-value .....	5.5–9
Silicon .....	< 20 mg SiO <sub>2</sub> /l
Iron .....	< 0.10 ppm
Manganese .....	< 0.05 ppm
Conductance .....	< 500 μS/cm
Organic contents, COD <sub>Mn</sub> .....	< 15 mg KMnO <sub>4</sub> /l

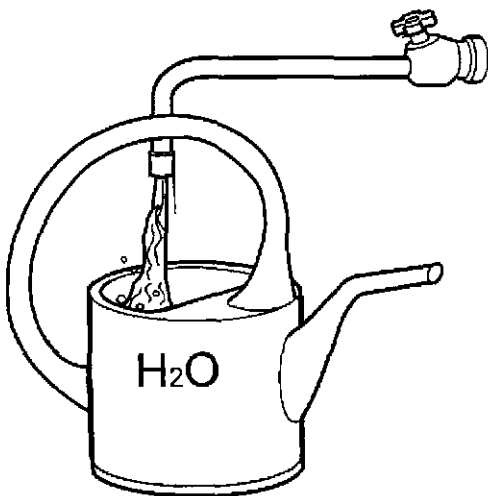

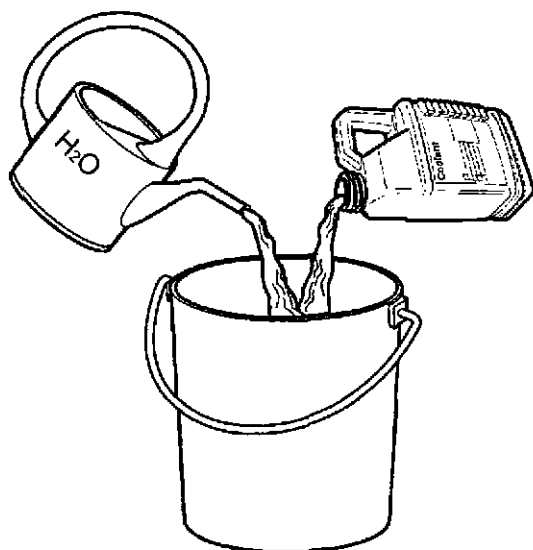

### Anti-freeze

If there is a risk of frost, use a mixture of 50% Volvo Penta anti-freeze (glycol) and 50% water (to ASTM D4985). This mixture prevents against frost bursting down to about  $-40^{\circ}\text{C}$  ( $-40^{\circ}\text{F}$ ), and should be used all year round.

**⚠ IMPORTANT!** Even if the temperature never gets as low as  $-40^{\circ}\text{C}$  these mixture proportions should be used to insure sufficient corrosion protection. See the table below.

Mix glycol with water in a separate container before filling the cooling system.

**⚠ WARNING!** Glycol is a health hazard (dangerous to ingest).

**⚠ IMPORTANT!** Alcohol may not be used in the cooling system.

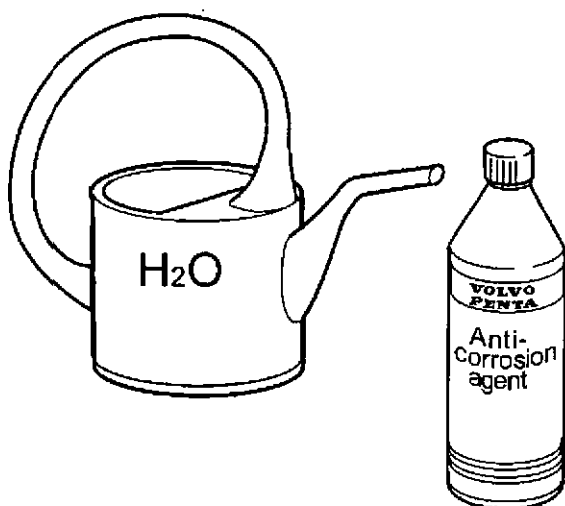

### Anti-corrosion mixture

When there is never a risk of freezing water (according to ASTM D4985) mixed with Volvo Penta corrosion protection may be used as coolant.

We recommend however that an anti-freeze mixture of 40% be used year-round, even in frost-free climates.

Mix according to the instructions on the package. Operate the engine until it is warm after filling to provide the best possible performance.

If the time of operation exceeds 400 hours per year the coolant's anti-corrosion protection must be replenished by use of 1/2 liter of corrosion protection every 400th operational hour.

**⚠ WARNING!** Corrosion protection is a health hazard (dangerous to ingest).

**⚠ IMPORTANT!** Never mix corrosion protection with anti-freeze (glycol). Foaming can occur which can seriously impair cooling.

## Coolant level, check

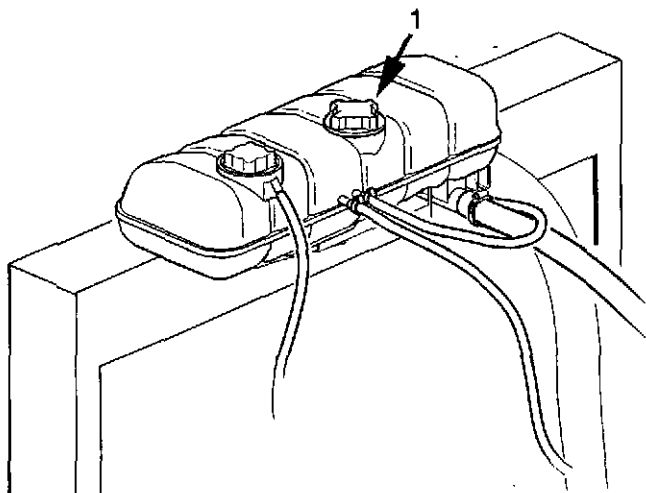

**⚠ WARNING!** Do not open the coolant filler cap (1) when the engine is warm. Steam or hot coolant can squirt out as pressure is released.

**NOTE!** Only open the filler cap (1).

The coolant level should be between the MIN and MAX markings. Add coolant as needed according to the description in "Adding, cooling system".

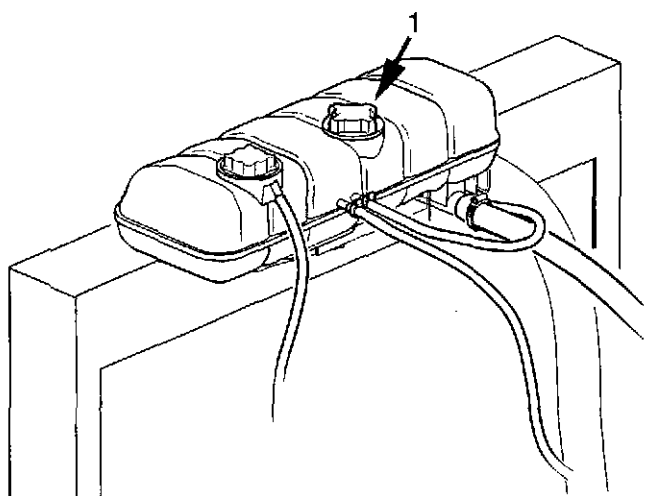

## Adding, cooling system

**⚠ WARNING!** Do not open the coolant filler cap (1) when the engine is warm. Steam or hot coolant can squirt out as pressure is released.

1. Open the filler cap (1).

**NOTE!** Use only Volvo Penta recommended coolant and mixtures.

2. Mix the correct amount of coolant ahead of time (see the table below) so that it can be assured that the system has been filled. Filling must not be done so quickly that air pockets form in the system. Air must be given the chance to flow out through the filler opening and drain valves.

When adding coolant, the coolant level should be between the MIN and MAX markings.

3. Start the engine when the cooling system has been bled of air and filled completely. If there is a heater attached to the engine's cooling system the heater control valve should be opened and the unit should also be bled of air during filling.

4. Stop the engine after approximately 1 hour, check the coolant level and add coolant as needed.

Coolant volume	
Volume (engine)	20 liters
Volume (engine, radiator + hoses)	44 liters

## Draining, cooling system

**⚠ WARNING!** Do not open the coolant filler cap (1) when the engine is warm. Steam or hot coolant can squirt out.

1. Remove the filler cap (1).
2. Open all of the drain valves. Drain the coolant from the radiator. Use drain hose that can be ordered from Volvo Penta, the drain valve (P) is located under the radiator.
3. Make sure that all coolant runs out. Deposits may exist just inside of the valves/plugs that must be cleaned away. If this is not done there is a risk that coolant will be left in the engine where it can cause serious damage.  
Check to see if the installation has additional valves or plugs at the lowest points of the coolant system.
4. Close the valves and replace any plugs.

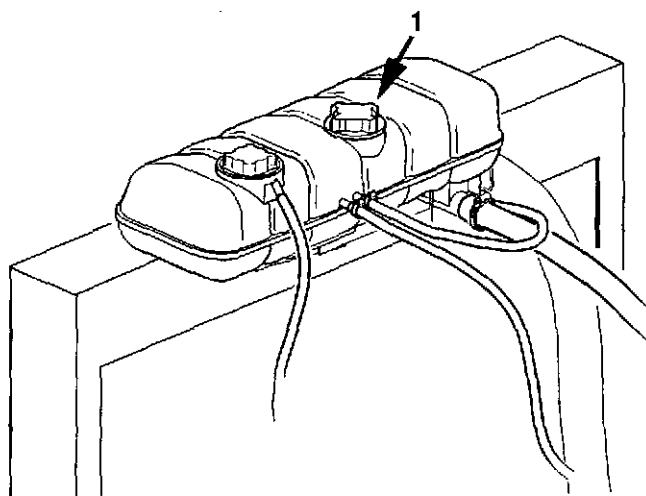

TAD

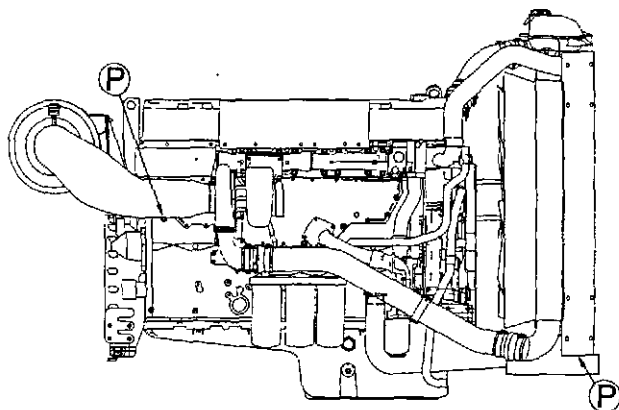

P = Coolant drain valve/plug

TWD

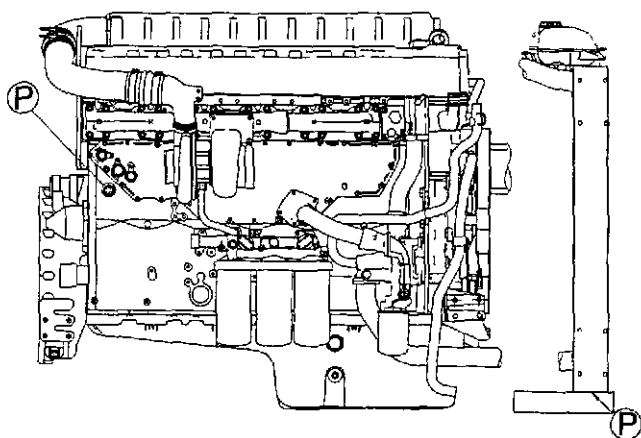

P = Coolant drain valve/plug

## Cooling system, flushing

1. Drain the cooling system, see "Draining, cooling system".

**NOTE!** If the cooling system is flushed regularly, for example by draining and refilling with rust-preventative fluid, a smaller amount of flushing additive or simple rinsing with clean water can be sufficient.

2. Rinse the cooling system clean with water.
3. Fill the cooling system with radiator flushing agent. Following this the engine should be operated for at least 2 hours after normal operating temperature has been reached.

**NOTE!** As an alternative the cooling system can be filled with 15–20% concentrated coolant which is drained after 1–2 days of operation.

4. Empty the cooling system and then rinse out the system with a neutralizing mixture.
5. If impurities still exist repeat the cleaning procedure until the system is free from impurities.
6. When the cooling system is completely clean, fill it with new coolant. In markets where Volvo Penta's concentrated coolant is not available, use anti-corrosive additives and water.

**NOTE!** Mix the correct amount ahead of time so that it can be established that the system is full.

## Coolant filter, change

1. Turn the valve (1) 90° to stop the flow through the coolant filter.
2. Remove the coolant filter using an appropriate filter wrench. Make sure that no residue from the old gasket remains on the housing.
3. Spread a thin layer of engine oil on the new coolant filter's gasket. Tighten the coolant filter by hand until the rubber seal contacts the sealing surface on the filter bracket. Tighten the coolant filter 1/2 turn.
4. Turn the valve (1) 90° to start the flow through the coolant filter again.
5. Start the engine and check for leaks.
6. Shut-off the engine and check the coolant level, see "Coolant level, check".

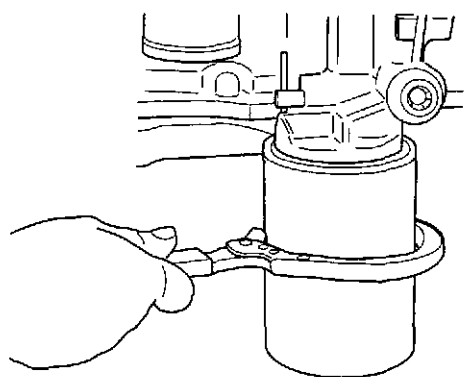
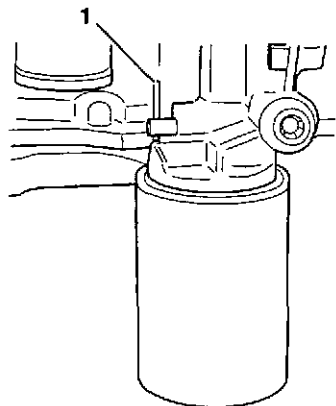

## Fuel system

Only use fuel of the recommended grade according to the fuel specification below. Always make sure to maintain a high level of cleanliness when fueling and when working with the fuel system.

All work involving the engine's unit injectors must be performed by an authorized service location.

**⚠ WARNING!** Risk of fire. Work on the fuel system must be performed on a cold engine. Fuel leakage and spillage onto hot surfaces or electrical components can cause a fire. Store fuel-soaked rags in a fire-safe manner.

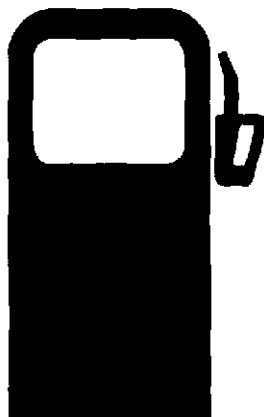

### Fuel specification

The fuel must at least satisfy national and international standards for market fuel, for example:

**EN 590** (with nationally adjusted environmental and temperature requirements)

**ASTM-D975-No. 1-D, 2-D**

**JIS KK 2204**

**Sulfur content:** According to legal requirements in each respective country. If the sulfur content exceeds 0.5 percent by weight **oil change intervals** must be changed, see "Lubrication system".

Note that low-density fuel (urban diesel in Sweden and citydiesel in Finland) can cause a power reduction of approximately 5% and a decrease in fuel economy of approximately 2–3%.

## Fuel filter, change

**NOTE!** Do not fill the new fuel filter with fuel prior to mounting, there is a risk that impurities can be introduced into the system causing operational interruptions or damage.

**⚠ WARNING!** Fuel filter replacement should be carried out on a cold engine to avoid the risk of fire caused by fuel spilling onto hot surfaces.

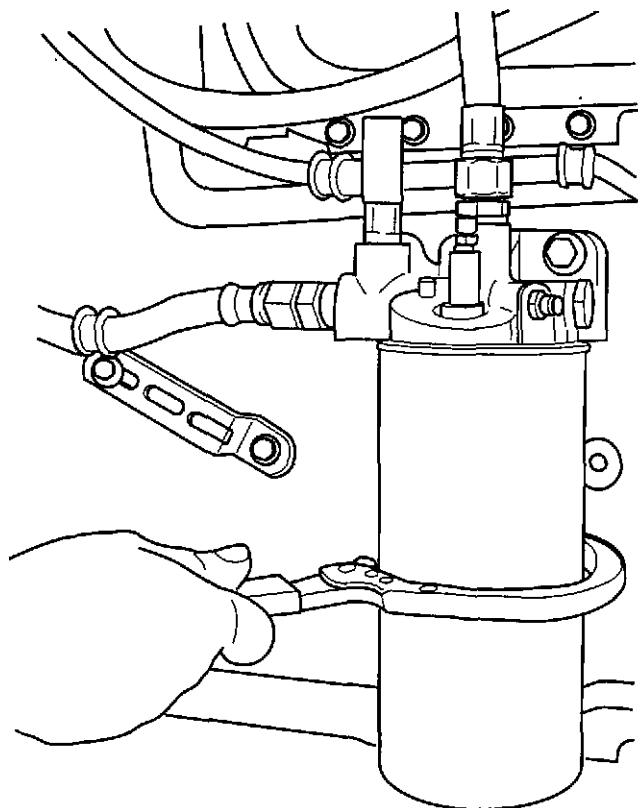

1. Clean the area around the fuel filter.
2. Drain the fuel filter, see "Fuel system, draining, condensation water".
3. Remove the filter using an appropriate filter wrench.
4. Clean the filter's sealing surface on the filter housing.
5. Spread a thin layer of oil on the sealing ring and mount the new fuel filter. Tighten the fuel filter according to the instructions on the filter.
6. Purge the fuel system in proximity to the fuel filter, see "Fuel system, purging".
7. Operate the engine at a higher idle speed for approximately 10 minutes to remove any remaining air from the system. Conduct leakage and functional checks.

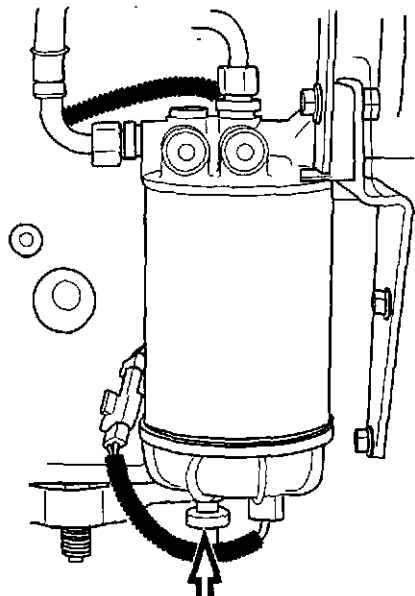

## Fuel pre-filter with water monitor, change

1. Clean the area around the fuel filter.
2. Disconnect the water monitor(1).
3. Drain the fuel filter, see "Fuel system, draining".
4. Remove the fuel filter using an appropriate filter wrench.

**NOTE!** If the entire filter unit with the water separator is not going to be changed the water monitor should be moved to the new fuel filter.

5. Clean the filter's sealing surface on the filter housing.
6. Spread a thin layer of oil on the sealing ring and mount the new fuel filter according to the instructions on the filter.
7. Connect the water monitor (1).
8. Start the engine and check for leaks.

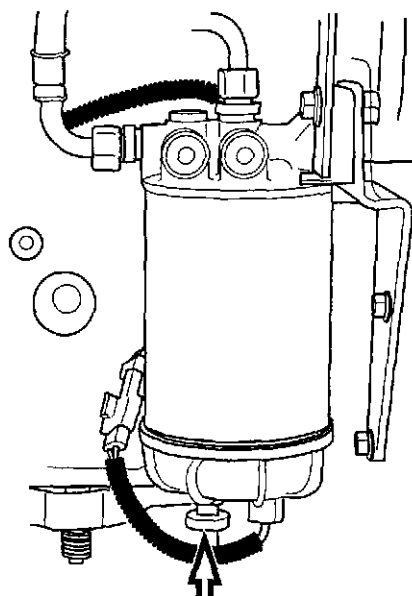

## Fuel pre-filter, draining of condensation water

**⚠ IMPORTANT!** Wait a few hours after the engine has been turned off before draining the filter.

1. Open the drain nipple (2) in the bottom of the fuel pre-filter and let the condensation water run out.

**NOTE!** Place a container under the fuel pre-filter to catch the condensation water and fuel.

2. Close the drain nipple (2) when water-free fuel comes out.
3. Start the engine and let the engine fill the water separator. Let the engine idle for 10 minutes to remove the air from the fuel system.
4. Shut off the engine and check for leaks.

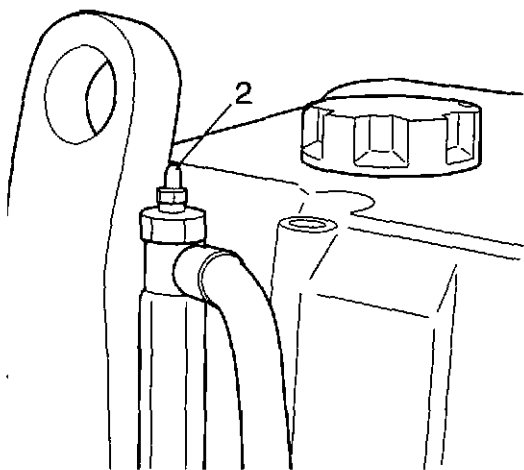
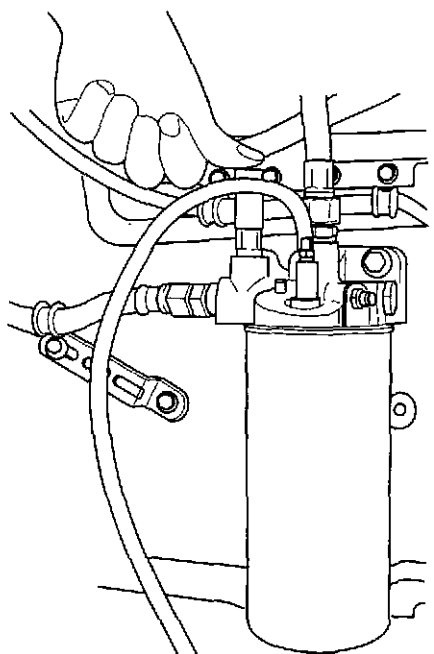
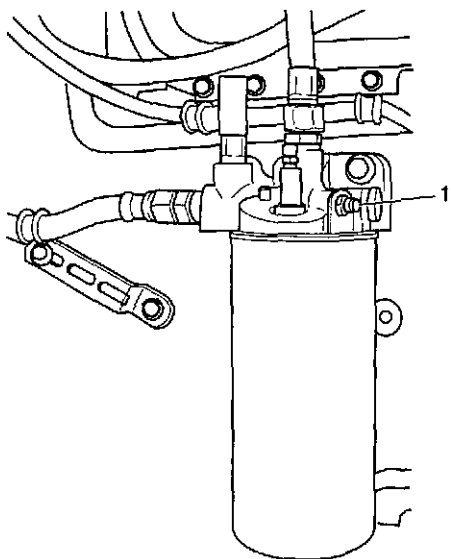

## Fuel system, purging

1. Clean around the purge nipples on the cylinder head and the fuel filter bracket.
2. Purge the fuel system at the fuel filter. Connect a transparent plastic hose between the purge nipples (1) and a collection vessel.
3. Open the purge nipple on the fuel filter bracket.
4. Pump with the hand pump until air-free fuel flows out. Close the purge nipple while the fuel is flowing out.
5. Remove the hose and replace the protective cap on the purge nipples.

**NOTE!** When changing the fuel filter no additional purging is required.

6. Move the hose to the cylinder head's purge nipple (2) and purge in the same manner as with the fuel filter bracket.
7. Run the engine at a higher idle speed for approximately 10 minutes to remove any remaining air from the system.
8. Conduct leakage and functional checks.

## Electrical system

The engine is equipped with a 2-pole electric system and with an alternator. System voltage is 24V.

**⚠ WARNING!** Before performing service on the electric system the engine should be stopped and the power disconnected at the main switch. All connections to battery chargers or other equipment must be disconnected.

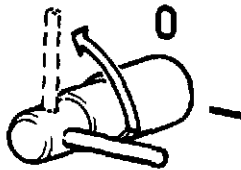

### Main switch

The main switch must never be switched off before the engine has been stopped. If the circuit between the generator and the battery is broken while the engine is running the generator and the electronics can be damaged. For the same reason reconnection of the charging circuits must never be carried out while the engine is running.

**⚠ IMPORTANT!** Never switch off the power with the main switch while the engine is running.

### Fuses

The engine is equipped with a 10A fuse that shuts off the power in case of an overload in the electrical system.

The fuse is placed adjacent to the engine control unit on the engine's left side.

**Note:** The engine will stop if the fuse (+) blows out.

If the fuse blows out often an authorized Volvo Penta repair facility should be contacted to investigate the cause of the overload.

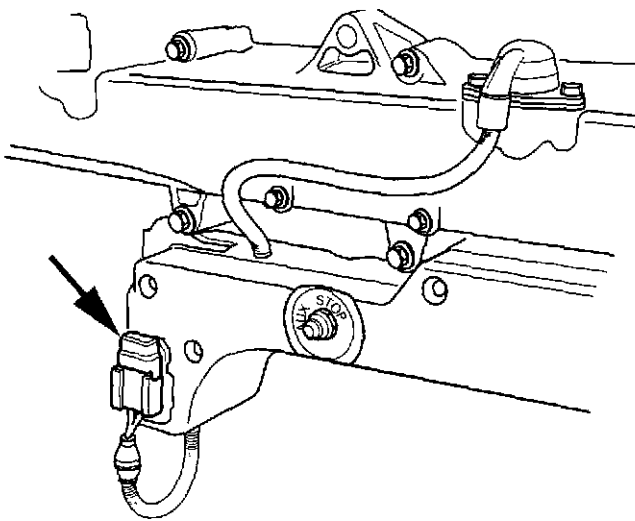



## Batteries, maintenance

**⚠ WARNING!** Fire and explosion risk. Batteries may never be exposed to open flame or sparks.

**⚠ WARNING!** Never confuse the plus and minus poles of the batteries. Risk of causing sparks and explosion.

**⚠ WARNING!** Battery electrolytes is strongly corrosive. Protect eyes, skin and clothing during all handling of batteries.

**⚠ WARNING!** Always use safety glasses and gloves. In case of skin contact, wash with soap and large quantities of water.

**⚠ WARNING!** In case of eye contact rinse immediately with large quantities of water and contact a doctor as soon as possible.

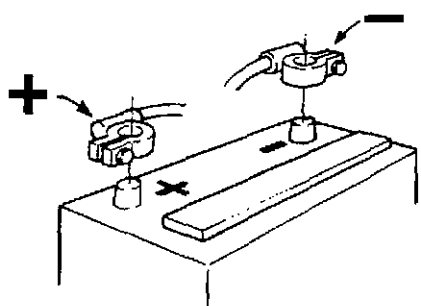

### Connection and disconnection

When connecting batteries first connect the + cable (red) to the battery's + pole. Then connect the - cable (black) to the battery's - pole.

When disconnecting batteries disconnect the - cable (black) first, then the + cable (red).

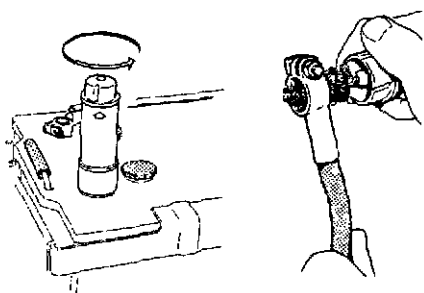

### Cleaning

Keep the batteries dry and clean. Contamination and oxidation on the battery and the battery poles can cause current leaks, a reduction in voltage and discharge, especially during times of humid weather. Clean oxidation from the battery poles and cable ends using a brass brush. Tighten the cable ends and protect them using pole grease or Vaseline.

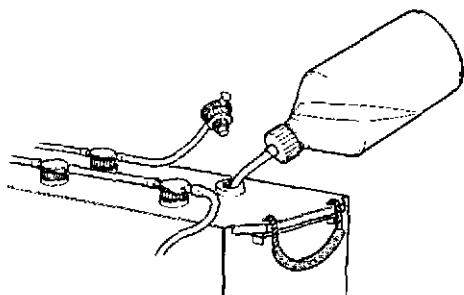

### Electrolyte level

The Electrolyte level should be 5–10 mm over the cell plates in the battery. Add battery water as needed.

After filling the batteries should be charged by being connected to a battery charger, or by running the engine in normal operation for at least 30 minutes.

**NOTE!** Certain maintenance-free batteries have special instructions that must be followed.

**⚠ IMPORTANT!** Never switch the batteries + pole and - pole.

## Batteries, charging

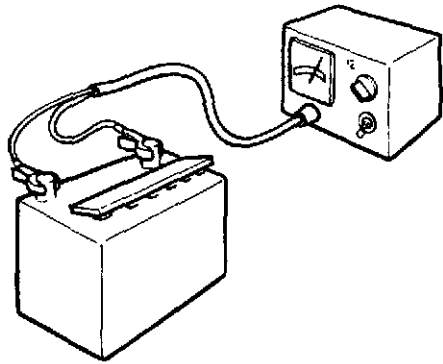

**⚠ WARNING!** Explosion risk. During charging oxyhydrogen gas is formed. Short-circuits, open flame or sparks can cause a powerful explosion. Ventilate well.

**⚠ WARNING!** Battery electrolyte is strongly corrosive. Protect eyes, skin and clothing. Always use safety glasses and gloves. In case of skin contact, wash with soap and large quantities of water. In case of eye contact rinse immediately with large quantities of water and contact a doctor as soon as possible.

Charge batteries if they have become discharged. If the engine is not used for an extended period the batteries should be fully charged initially and receive periodic maintenance charging (see the battery manufacturers recommendations). A discharged state damages batteries and they can also freeze and break during cold weather.

**⚠ IMPORTANT!** Carefully follow all instructions for the battery charger. To avoid risk for electrochemical corrosion when using an external charger when an external charger is used the battery cables should be removed from the battery before the charger is connected.

During charging the cell plugs should be unscrewed but remain in the plugholes. Ventilate well, especially if the battery is being charged in an enclosed space.

**⚠ WARNING!** Always turn off the charger before loosening the charging clamps. Never confuse the + and - poles of the batteries. Risk of causing sparks and explosion.

There are special instructions for so-called **quick-charging**. Quick-charging can shorten the useful life of the battery and should therefore be avoided.

## Electric component schematic

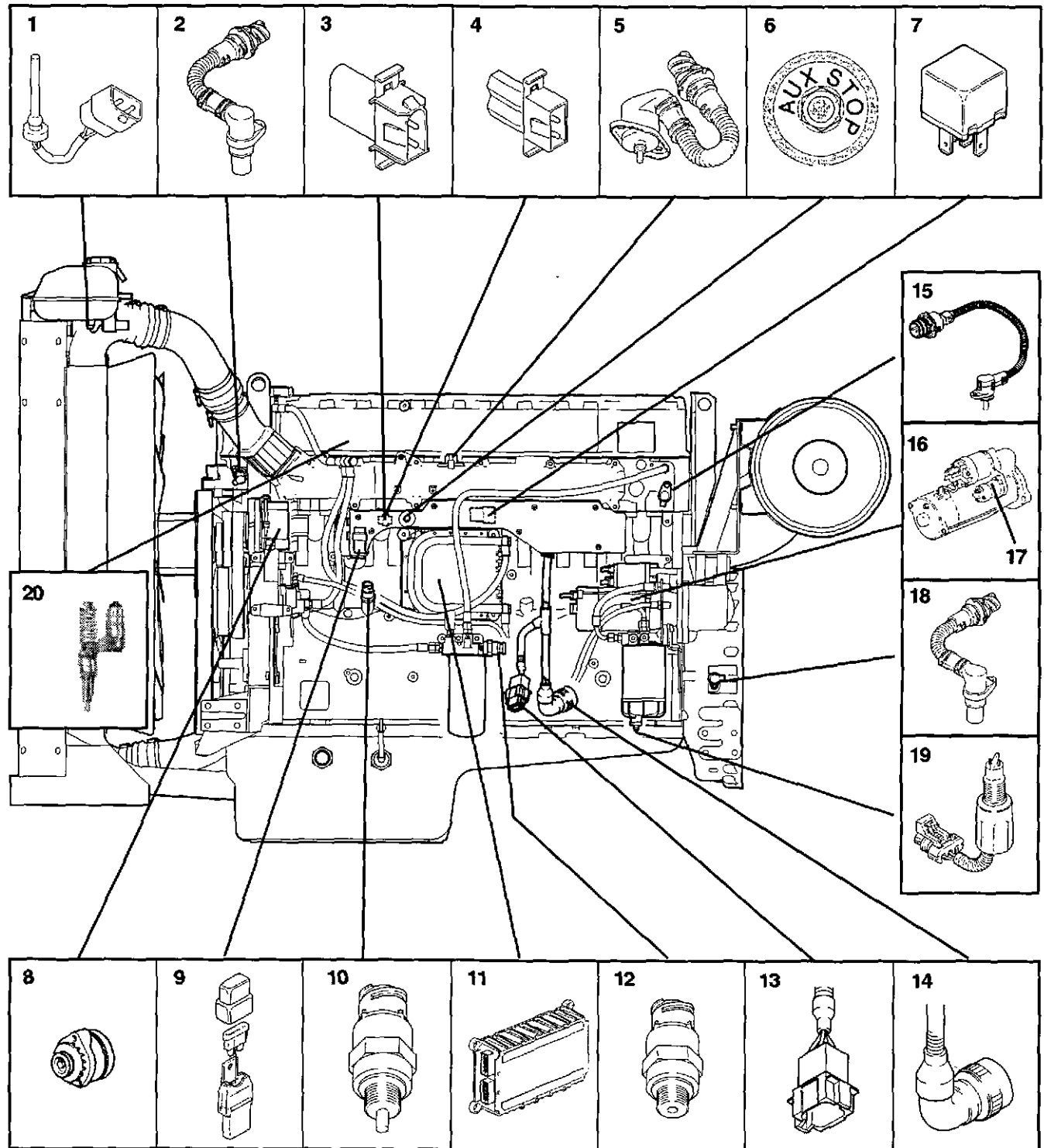

- |   |   |
|---|---|
| 1. Coolant level sensor                     | 11. Control unit (EMS)                    |
| 2. RPM sensor, camshaft                     | 12. Fuel pressure alarm                   |
| 3. Diagnostic outlet                        | 13. 8-pin connector                       |
| 4. Programming connection                   | 14. 23-pin connector                      |
| 5. Boost pressure/intake temperature sensor | 15. Coolant temperature sensor            |
| 6. Extra stop                               | 16. Starter motor                         |
| 7. Main relay                               | 17. Starter motor, relay                  |
| 8. Generator                                | 18. RPM sensor, flywheel                  |
| 9. Safety fuse 10A                          | 19. Water monitor, fuel filter            |
| 10. Oil pressure/Oil temperature sensor     | 20. Unit injector (one for each cylinder) |

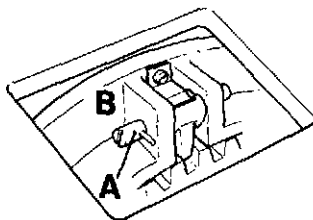
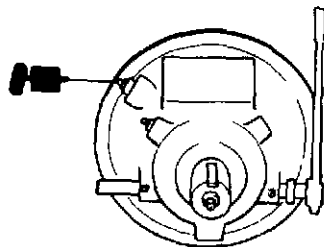
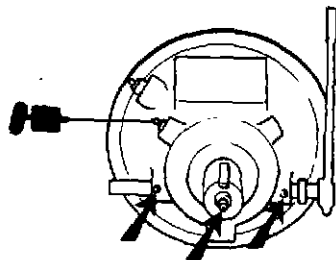

## Clutch

### Lubrication

Use lithium-based grease such as Mobilux EP2, Statoil Uniway EP2N, Texaco Multifac EP2, Q8 Rembrandt EP2.

### Main bearing and clutch mechanism

Grease the inner support bearing (where there are grease fittings), main bearing, declutching shaft and the *clutch mechanism's moving parts with grease*. Grease sparingly (20–30 grams for the main bearing).

Grease the inner link arms with a few drops of oil.

### Declutching bearing

Lubricate sparingly so that no grease squeezes out. Use grease matching the recommendation above.

### Check/adjust

**⚠ WARNING!** Adjustment must be done on a *stopped engine*.

Engagement force at the end of the lever should be 36–45 kp during engagement.

**Adjustment:** Remove the inspection cover. Loosen the barrier (A) and twist the red adjuster (B) clockwise. Lock the barrier. The plates must not slip after engagement!

# Preparation for storage

To prevent the engine and other equipment from suffering damage during periods of storage exceeding two months a preservation procedure should be performed. It is important that this be done correctly and that no part of it be forgotten. We have therefore created a checklist covering the most important points.

Before the engine is taken out of service for an extended period an authorized Volvo Penta service facility should perform a check.

Problems should be addressed at this point so that the equipment will be ready for use when needed next.

**⚠ WARNING!** Prior to starting maintenance work the chapter "Maintenance" should be read carefully. In it you will find instructions for how the work can be carried out in a safe and correct manner

**⚠ WARNING!** Certain preservation oils are flammable. Some even produce dangerous fumes. Make sure that there is good ventilation. Use a protective mask when spraying.

**⚠ IMPORTANT!** When cleaning with a high-pressure sprayer the following instructions must be kept in mind: Never point the spray at seals, rubber hoses or electric components. Never use the high-pressure function while cleaning the engine.

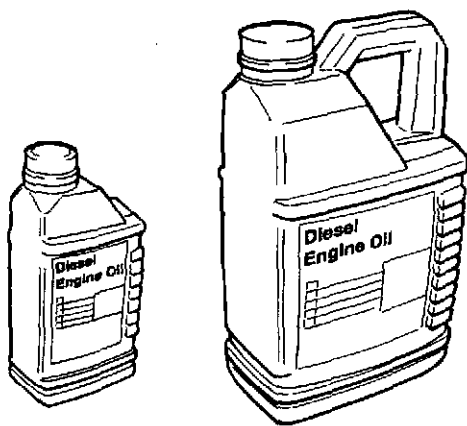

## Preparation for storage

### ● For periods of storage up to 8 months:

Change the engine oil and oil filter and then run until warm.

### For periods of storage longer than 8 months:

Preserve the lubrication and fuel systems with preservation oil. **See instructions on next page.**

- Make sure that the coolant's freeze protection is sufficient. Supplement as needed. As an alternative the coolant can be drained (drain also the coolant filter).
- Drain off any water and contamination from the fuel filter and the fuel tank. Fill the tank completely full with fuel to avoid building of condensation.
- Disconnect the battery cables and clean and charge the batteries. Maintenance charge the batteries periodically during the storage period. **A poorly charged battery can freeze and break.**
- Clean the engine externally. Do not use high-pressure spray when cleaning the engine. Touch-up paint damage using Volvo Penta original paint.
- Spray the electrical system's components with a water displacing spray.
- Check and treat control cables using rust-preventative.
- Affix a note on the engine showing the date, type of preservation and type of preservation oil is provided.
- Cover the air filter, exhaust pipe and the engine if called for.

## Preparation for use after storage

- Remove any covers from the engine, air filter and exhaust pipe.
- Fill the engine with the proper grade of lubricating oil as needed. Mount a new oil filter if a filter change was not performed in conjunction with the preservation process.
- Mount a new fuel filter and purge the fuel system.
- Check the drive belt/s.
- Check the condition of the hoses and check-tighten the hose clamps.
- Close the drain valves and replace any drain plugs.
- Check the coolant levels. Add as needed.
- Connect the fully charged batteries.
- Start the engine and run until warm at a high idle speed prior to apply load to the engine.
- Check that no leakage of oil, fuel or coolant occurs.

### Preservation of lubrication and fuel systems for storage exceeding 8 months:

- Drain the oil from the engine and fill it with **preserving oil\*** to just over the MIN marking on the dipstick.
- Connect the suction and return fuel lines to a container filled with 1/3 **preservation oil\*** and 2/3 diesel fuel.
- Purge the fuel system.
- Start the engine and operate at a high idle speed until approximately two liters have been used. Shut off the engine and connect the normal fuel lines.
- Empty the preservation oil from the engine.
- Follow otherwise the instructions on the previous page.

\*Preservation oil is distributed by oil manufacturers.

# Troubleshooting

A number of symptoms and possible causes for engine problems are described in the table below. Always contact your Volvo Penta dealer if problems occur that you are not able to solve on your own.

**⚠ WARNING!** Read through the safety instructions for maintenance and service work in the chapter "Safety information" before starting to work.

Symptoms and possible causes	
⚡ Diagnostic button's indicator is blinking	See the chapter "Diagnostic function".
The engine can not be stopped	2, 5
The starter motor does not turn over	1, 2, 3, 4, 5, 6, 7, 8, 25
The starter motor turns slowly	1, 2
The starter motor turns normally but the engine does not start	9, 10, 11, 12
The engine starts but stops again	9, 10, 11, 12, 14
The engine does not reach the correct operational RPM with full throttle	10, 11, 12, 13, 14, 15, 22, 26
The engine does not run smoothly	11, 12
Poor fuel economy	13, 14, 16, 26
Black exhaust smoke	13, 14
Blue or white exhaust smoke	15, 16, 23
Insufficient lubricating oil pressure	17
Excessive coolant temperature	18, 19, 20, 21
Insufficient coolant temperature	21
Absent or poor charging	2, 24

- |  |  |   |
|--|--|---|
| 1. Discharged batteries  | 11. Air in the fuel system   | 17. Insufficient lubrication oil level      |
| 2. Poor connection/broken wires  | 12. Water/contamination in the fuel  | 18. Low coolant level                       |
| 3. Main switch turned off  | 13. Malfunctioning injector (injectors)  | 19. Air in the fresh water coolant system   |
| 4. Fuse on the wiring box blown  | 14. Insufficient air to the engine:<br>- blocked air filter<br>- air leakage between the turbo and the engine intake plenum<br>- contaminated compressor section in the turbocharger<br>- malfunctioning turbocharger<br>- poor engine compartment ventilation | 20. Malfunctioning circulation pump         |
| 5. Malfunctioning start lock   | 15. Excessive coolant temperature  | 21. Defective thermostat                    |
| 6. Malfunctioning main relay   | 16. Insufficient coolant temperature   | 22. Blocked intercooler                     |
| 7. Malfunctioning starter motor relay  |  | 23. Excessive lubricating oil level         |
| 8. Malfunctioning starter motor/solenoid   |  | 24. Generator drive belt slippage           |
| 9. Out of fuel:<br>- fuel valves closed<br>- fuel tank empty/wrong tank connected                                      |  | 25. Water inside the engine                 |
| 10. Blocked fuel filter/pre-filter (because of contamination or paraffin condensation in the fuel at low temperatures) |  | 26. High backpressure in the exhaust system |

# Diagnostic function

## Diagnostic function

The diagnostic function checks that the EDCIII system is functioning normally.

**The diagnostic function has the following functions:**

- To detect and localize disturbances
- To inform that disturbances have been detected
- To assist in the determination of the cause of the problem
- To protect the engine and to insure the ability to control the engine when serious disturbances are detected.

### Messages regarding disturbances

If the diagnostic function detects a disturbance in the EDCIII system the operator is notified by blinking of the diagnosis button's indicator (1).

### Problem identification

If the diagnosis button (2) is pushed and then released an error code blinks out (1). This code can be located in the list of error codes with information on the cause, response and measures to be taken.

**The diagnostic function affects the engine in the following manner when:**

1. The diagnostic function has detected a minor disturbance that will not damage the engine:  
**Response:** The engine is not affected.
2. The diagnostic function has detected a serious disturbance that can not immediately damage the engine (i.e. high coolant temperature):  
**Response:** TAD1240-42GE: The engine shuts down.  
TWD1240VE: Engine torque is reduced until the value normalizes.
3. The diagnostic function has detected a serious disturbance that makes it impossible to control engine operation:  
**Response:** TAD1240-42GE: RPM maintained.  
TWD1240VE The engine goes to idle.

### If the diagnosis button's indicator blinks

1. Reduce RPM to idle.
2. Push the diagnosis button (2) to acknowledge the message.
3. Release the diagnosis button and note the error code that blinks out (1). See "Reading error codes".
4. Look up the error code in the error code list and take the recommended corrective actions.

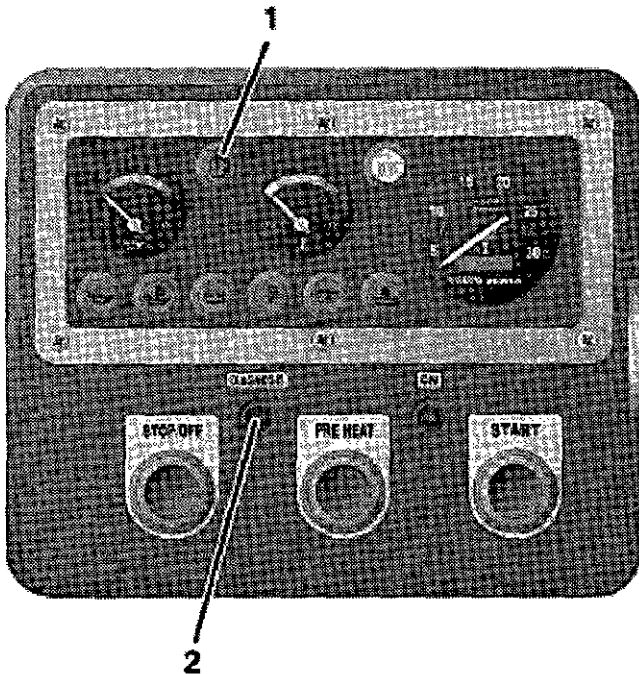

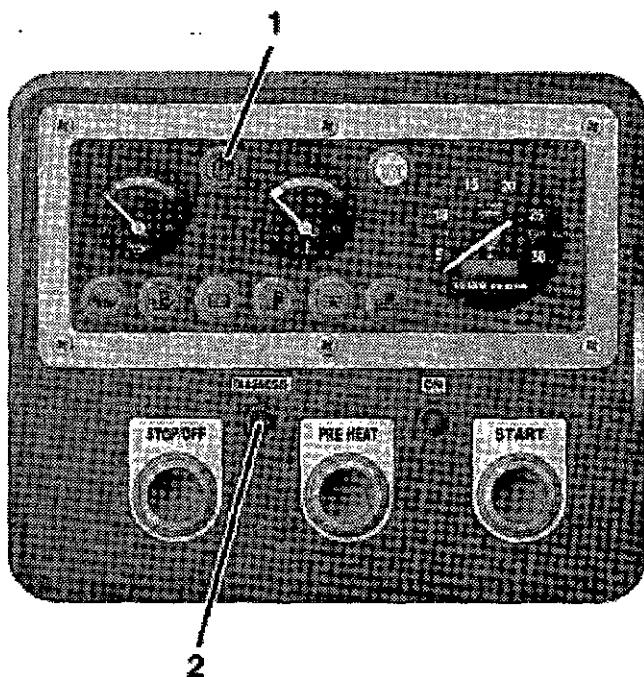

**NOTE!** If the warning display and the instrumentation indicates normal function. The operator can choose to continue operation and take corrective actions later on. If the engine is shut down certain error codes can disappear

### Reading out error codes

If the diagnosis button (2) is pushed and then released an error code blinks out (1).

The error code consists of two groups of blinks separated by a two-second pause. The error code is read by counting the number of blinks in each group.

**Example:** ✨ ✨ pause ✨ ✨ ✨ ✨ = Error code 2.4  
The error code is saved and can be read out as long as the disturbance is present. The error code list contains information on causes, responses and measures to be taken.

### Read out as follows:

1. Push the diagnosis button (2).
2. Release the diagnosis button and note the error code that blinks out (1).
3. Repeat points 2–3. A new error code blinks out if more codes are stored. Repeat until the first error code reappears.

**NOTE!** When the first error code reappears all error codes have been read out.

### Erasing error codes

The diagnosis function's error code memory is reset every time the engine power is turned off.

**NOTE!** The power must be completely disconnected.

When the power is turned on the diagnostic function checks to see if there are any disturbances in the EDCIII system. If disturbances are present new error codes are set.

### This means that:

1. Error codes for disturbances that have been corrected or that have disappeared are erased automatically.
2. Error codes for disturbances that have not been corrected must be acknowledged and read out every time the power is turned on.

If the diagnosis button is pushed after the error has been corrected and saved error codes are erased the code 1.1 ("No errors") will blink out.

# Diagnostic Trouble Codes (DTCs)

**⚠ WARNING!** Read the safety instructions for maintenance and service work in the chapter "Safety information" before starting to work.

## Code 2.1

**Cause:** Water detected in the fuel or insufficient fuel pressure.

**Response:** Alarm indicator lights up.

**Corrective action:**

- Check fuel water separator filter (drain the tank as well).
- Check if it is possible to increase the pressure using the hand pump.
- Check the fuel filter.
- Check the pre-filter.

## Code 2.2

**Cause:** Low coolant level.

**Response:** The engine shuts down (if this protective feature has not been disabled by the parameter setting tool). The alarm indicator lights up.

**Corrective action:**

- Check coolant level.
- Check coolant level sensor.

## Code 2.4

**Cause:** RPM sensor, flywheel.

**Response:** The engine is very hard to start and runs poorly if it does start.

**Corrective action:**

- Check that the sensor connector is engaged correctly.
- Check the wiring to the sensor.
- Check that the sensor is located correctly in the flywheel cover.
- Check that the sensor is functional.

## Code 2.5

**Cause:** RPM sensor, camshaft.

**Response:** The engine takes longer than normal to start. The engine runs normally once underway.

**Corrective action:**

- Check that the sensor connector is engaged correctly
- Check the wiring to the sensor.
- Check that the sensor is located correctly in the cam cover.
- Check that the sensor is functional

## Code 2.7

**Cause:** Throttle potentiometer connected to EMS.

**Response:** The engine goes to idle. If the pedal is first released and then pushed down again the engine can be operated on an emergency basis with the help of the idle switch. (TAD1240-42GE)

**Corrective action:**

- Check that the control's connector is engaged correctly.
- Check that the potentiometer is connected correctly.
- Check that the wiring to the potentiometer is not damaged.
- Check the potentiometer.
- Check that the 23-pole connector is correctly assembled.

**Code 2.8**

**Cause:** Throttle potentiometer connected to CIU.

**Response:** The engine goes to idle. If the pedal is first released and then pushed down again the engine can be operated on an emergency basis with the help of the idle switch. (TAD1240-42GE)

**Corrective action:**

- Check that the potentiometer is connected correctly.
- Check that the wiring to the potentiometer is not damaged.
- Check the potentiometer.

**Code 3.1**

**Cause:** Oil pressure sensor.

**Response:** None.

**Corrective action:**

- Check that the wiring to the sensor is not damaged.
- Check that the sensor is connected correctly.

**Code 3.2**

**Cause:** Intake air temperature sensor.

**Response:** None.

**Corrective action:**

- Check that the sensor connector is engaged correctly.
- Check the wiring to the sensor.
- Check that the sensor is mounted correctly.
- Check that the sensor is functional.

**Code 3.3**

**Cause:** Coolant temperature sensor.

**Response:** Pre-heating is activated even if the engine is warm.

**Corrective action:**

- Check that the sensor connector is engaged correctly.
- Check the wiring to the sensor.
- Check that the sensor is mounted correctly.
- Check that the sensor is functional.

**Code 3.4**

**Cause:** Charge air sensor.

**Response:** The engine smokes more than it usually does when accelerating/under loading.

**Corrective action:**

- Check that the wiring to the sensor is not damaged.
- Check that the sensor is functional.
- Check that the sensor is mounted correctly.
- Check that the sensor is functional.

**Code 3.7**

**Cause:** Oil temperature sensor.

**Response:** None.

**Corrective action:**

- Check that the wiring to the sensor is not damaged.
- Check that the sensor is connected correctly.

**Code 4.1**

**Cause:** Oil pressure warning lamp.

**Response:** Warning lamp does not function. The diagnosis is activated if a circuit interruption is detected during start-up.

**Corrective action:**

- Check the warning lamp.
- Check the wiring and connection to the warning lamp.

**Code 4.2**

**Cause:** Warning lamp high coolant temperature.

**Response:** None.

**Corrective action:**

- Check that the warning lamp is correctly mounted.
- Check the warning lamp for run-indication.
- Check the wiring and connection to the warning lamp.

**Code 4.3**

**Cause:** Run-indication.

**Response:** None.

**Corrective action:**

- Check the warning lamp.
- Check the wiring and connection to the run-indicator warning lamp.

**Code 4.4**

**Cause:** Overspeed warning lamp.

**Response:** None.

**Corrective action:**

- Check the warning lamp.
- Check the wiring and connection to the warning lamp.

**Code 4.5**

**Cause:** Low coolant level warning lamp.

**Response:** None.

**Corrective action:**

- Check the coolant level warning lamp.
- Check the wiring and connection to the warning lamp.

**Code 4.6**

**Cause:** Starter motor relay.

**Response 1:** Engine will not start.

*The engine is to be started -> The engine turns over immediately when the ignition is pushed.*

**Response 2:** The engine is running -> The starter motor engages even though no start command was initiated.

*The engine is being started -> The starter motor does not disengage once the engine has started.*

**Corrective action:**

- Check the wiring to the relay.
- Check that the relay is unbroken.
- Check that the cable to the starter motor (yellow/black cable) is connected correctly.
- Check that the yellow/black cable is not damaged.
- Check that the starter motor relay is unbroken.

**Code 4.7**

**Cause:** Start initiation EMS.

**Response:** Engine will not start. The engine can only be stopped using the emergency stop on the engine.

**Corrective action:**

- Check the wiring to the ignition key/button.

**Code 5.1**

**Cause:** Main relay.

**Response:** The instrument panel loses power when the key is twisted to start position. The engine will not start.

**Corrective action:**

- Check the wiring to the relay.
- Check that the relay is unbroken.

**Code 5.2**

**Cause:** Start initiation for CIU.

**Response:** The engine can not be started.

**Corrective action:**

- Check the connections to the ignition key.
- Check the wiring to the ignition key.

**Code 5.3**

**Cause:** Stop initiation for CIU.

**Response:** The engine can only be stopped using the emergency stop on the engine.

**Corrective action:**

- Check the connections to the ignition key.
- Check the wiring to the ignition key.

**Code 5.4**

**Cause:** Pre-heating relay.

**Response:** Pre-heating can not be activated.

**Corrective action:**

- Check the wiring to the entrance to the relay.
- Check that the relay is unbroken.

**Code 5.8**

**Cause:** Oil temperature is too high.

**Response:** The engine limits the available power output (if this protective feature has not been disabled by the parameter setting tool). The alarm indicator lights up.

**Corrective action:**

- Check the oil level.
- Check coolant temperature.
- Check oil system thermostat.
- Check that the oil sensor is functional.

**Code 6.1**

**Cause:** Coolant temperature is too high.

**Response:** TWD1240VE: The engine shuts down (if this protective feature has not been disabled by the parameter setting tool). The alarm indicator lights up.

TAD1240-42GE: The engine limits the available power output (if this protective feature has not been disabled by the parameter setting tool). The alarm indicator lights up.

**Corrective action:**

- Check coolant level.
- Check the radiator (cleanliness).
- Check for air in the coolant system.
- Check the pressure cap.
- Check the coolant temperature sensor.
- Check the thermostat function.

**Code 6.2**

**Cause:** Intake air temperature is too high.

**Response:** Engine output is limited to 50% (if this protective feature has not been disabled by the parameter setting tool).

**Corrective action:**

- Check coolant level.
- Check the intercooler/aftercooler (cleanliness).
- Check the intake air temperature sensor.
- Check the thermostat function.

**Code 6.4**

**Cause:** Datalink (CAN) error, CIU.

**Response:** Instruments and lights no longer function

**Corrective action:**

- Check the 8-pole connector.
- Check the 8-pole wiring between the CIU and the engine control unit (EMS).

**Code 6.5**

**Cause:** Datalink (CAN) error, EMS.

**Response:**

**Corrective action:**

- Check the 8-pole connector.
- Check the 8-pole wiring between the CIU and the engine control unit.

**Code 6.6**

**Cause:** Oil pressure is too low.

**Response:** The engine shuts down (if this protective feature has not been disabled by the parameter setting tool). The alarm lamp lights up.

**Corrective action:**

- Check the oil level.
- Check that the oil filter is not blocked.
- Check the system pressure valves and the safety valve in the oil system.
- Check that the oil sensor is functional.

**Code 7.1**

**Cause:** Problem with the compression or the injector for cylinder #1. Electric error.

**Response 1:** Cylinder balance is adversely affected -> uneven running at low RPM and low load.

**Response 2:** The engine runs on 5 cylinders, sounds uneven and has decreased performance.

**Corrective action:**

- Check fuel feed pressure.
- Check valve lash.
- Check the injector and the connector wiring.
- Do a compression test and check cylinder #1.

**Code 7.2**

**Cause:** Problem with the compression or the injector for cylinder #2. Electric error.

**Response 1:** Cylinder balance is adversely affected -> uneven running at low RPM and low load.

**Response 2:** The engine runs on 5 cylinders, sounds uneven and has decreased performance.

**Corrective action:**

- Check fuel feed pressure.
- Check valve lash.
- Check the injector and the connector wiring.
- Do a compression test and check cylinder #2.

**Code 7.3**

**Cause:** Problem with the compression or the injector for cylinder #3. Electric error.

**Response:** Cylinder balance is adversely affected -> uneven running at low RPM and low load.

The engine runs on 5 cylinders, sounds uneven and has decreased performance.

**Corrective action:**

- Check fuel feed pressure.
- Check valve lash.
- Check the injector and the connector wiring.
- Do a compression test and check cylinder #3.

**Code 7.4**

**Cause:** Problem with the compression or the injector for cylinder #4. Electric error.

**Response:** Cylinder balance is adversely affected -> uneven running at low RPM and low load.

The engine runs on 5 cylinders, sounds uneven and has decreased performance.

**Corrective action:**

- Check fuel feed pressure.
- Check valve play.
- Check the injector and the connector wiring.
- Do a compression test and check cylinder #4.

**Code 7.5**

**Cause:** Problem with the compression or the injector for cylinder #5. Electric error.

**Response:** Cylinder balance is adversely affected -> uneven running at low RPM and low load.

The engine runs on 5 cylinders, sounds uneven and has decreased performance.

**Corrective action:**

- Check the wiring to the injector.
- Check the connections to the injector.
- Do a compression test and check cylinder #5.

**Code 7.6**

**Cause:** Problem with the compression or the injector for cylinder #6. Electric error.

**Response:** Cylinder balance is adversely affected -> uneven running at low RPM and low load.

The engine runs on 5 cylinders, sounds uneven and has decreased performance.

**Corrective action:**

- Check fuel feed pressure.
- Check valve lash.
- Check the injector and the connector wiring.
- Do a compression test and check cylinder #6.

**Code 9.8**

**Cause:** EEPROM error, CIU.  
Controller failure, CIU.

**Response:** The engine goes to idle.

The engine can not be started, if the engine is running -> idle.

**Corrective action:**

- Change the CIU unit

**Code 9.9**

**Cause:** Memory error in the engine control unit.

**Response:** Engine will not start.

**Corrective action:**

- Change the control unit.

# Technical Data

## General

Type designation .....	TAD1240GE	TAD1241-42GE	TWD1240VE
Number of cylinders .....	6	6	6
Cylinder diameter .....	131 mm	131 mm	131 mm
Stroke .....	150 mm	150 mm	150 mm
Displacement .....	12.13 liters	12.13 liters	12.13 liters
Number of valves .....	24	24	24
Rotational direction (seen from the front) .....	Clockwise	Clockwise	Clockwise
Compression ratio .....	18.5:1	17.5:1	18.5:1
Firing order .....	1-5-3-6-2-4	1-5-3-6-2-4	1-5-3-6-2-4
Low idle, adjustable (RPM) .....	600-1200	600-1200	600-900
High idle, adjustable (RPM) .....	1500-1620 <sup>1)</sup> /1800-1920	1500-1620 <sup>1)</sup> /1800-1920	2100 <sup>1)</sup> 2100
Highest full load RPM .....	1500/1800	1500/1800	2100
Dry weight (kg) .....	1230 <sup>2)</sup>	1230 <sup>2)</sup>	1270

<sup>1)</sup> Not adjustable

<sup>2)</sup> Weight of TAD engines without cooling package and air filter

## Lubrication system

**Oil Change volume including change of three filters:**

With horizontal installation ..... 35 liters

**Oil pressure**

at Operational speed 1100 RPM or higher ..... 400–550 kPa

Idle, min ..... 175 kPa

Oil grade ..... See specification under "Lubrication system".

Viscosity ..... See specification under "Lubrication system".

### Oil filter

Number ..... 3

Full-flow filter

(tightened 1/2–3/4 turn after sealing surface contact) . 2

Bypass filter

(tightened 3/4–1 turn after sealing surface contact) .... 1

### Oil pump

Type ..... Gear driven

## Fuel system

### Injection order

Injection order ..... 1-5-3-6-2-4

### Feed pump

Feed pressure after fuel filter at  
1000 RPM, min. .... 350 kPa

Feed pressure after fuel filter at  
full load, min. .... 350 kPa

### Overflow valve

Opening pressure ..... 400–450 kPa

## Fuel specification

The fuel must at least satisfy national and international standards for market fuel, for example:

**EN 590** (with nationally adjusted environmental and temperature requirements)

**ASTM-D975 No. 1-D and 2-D**

**JIS KK 2204**

**Sulfur content:** According to legal requirements in each respective country.

Low-density fuel (urban diesel in Sweden and citydiesel in Finland) can cause a power reduction of approximately 5% and a decrease in fuel economy of approximately 2–3%.

## Cooling system

### General

	TAD1240-42GE	TWD1240VE
Type .....	Overpressure, closed	
Pressure valve opens at .....	75 kPa	75 kPa
Volume (engine) .....	20 liters	20 liters
Volume (engine + radiator and hoses) .....	44 liters	44 liters

### Thermostat

Type .....	Piston thermostat	Piston thermostat
Number .....	1	1
Opening temperature .....	86°C	75°C

### Coolant filter

Number .....	1	1
--------------	---	---

## Electrical system

System voltage .....	24 V
<b>Alternator:</b>	
voltage/max. current .....	28 V/60 A
power approx. ....	1700 W
<b>Battery capacity</b> .....	2 serial-connected 12 V, max. 152 Ah
Battery electrolyte density at +25°C:	
fully charged battery .....	1.28 g/cm <sup>3</sup> (1.24 g/cm <sup>3</sup> )*
the battery discharges at .....	1.24 g/cm <sup>3</sup> (1.20 g/cm <sup>3</sup> )*

\* **Note:** Applies to batteries with tropical electrolyte.