

**WISCONSIN
MODEL VH4D**

V
H
4
D

**REPAIR
MANUAL**

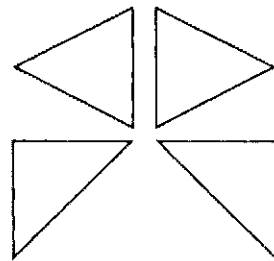

 **WIS-CON
TOTAL POWER** CORP.

FOREWORD

Good operation and a planned maintenance program as outlined in this manual are vital in obtaining maximum engine performance and long engine life. The instructions on the following pages have been written with this in mind, to give the operator a better understanding of the various problems which may arise, and the manner in which these problems can best be solved or avoided.

The operator is cautioned against the use of any parts, other than genuine Wis-Con Total Power parts, for replacement or repair. These parts have been engineered and tested for their particular job, and the use of any other parts may result in unsatisfactory performance and short engine life. Wis-Con Total Power distributors and dealers, because of their close factory relations, can render the best and most efficient service.

THE LIFE OF YOUR ENGINE DEPENDS ON THE CARE IT RECEIVES.

The MODEL, SPECIFICATION and SERIAL NUMBER of your engine must be given when ordering parts. The MODEL and SPECIFICATION number are on the name plate. The SERIAL NUMBER is stamped either on the crankcase or the engine's identification tag.

Copy the MODEL, SPECIFICATION and SERIAL NUMBER in the spaces provided below so that it will be available when ordering parts.

MODEL

SPECIFICATION

SERIAL NUMBER

To insure prompt and accurate service, the following information must also be given:

1. State EXACTLY the quantity of each part and part number.
2. State definitely whether parts are to be shipped by express, freight or parcel post.
3. State the exact mailing address.

IMPORTANT

READ THESE INSTRUCTIONS CAREFULLY

All points of operation and maintenance have been covered as carefully as possible, but if further information is required, send inquiries to the factory for prompt attention.

When writing to the factory, ALWAYS GIVE THE MODEL, SPECIFICATION AND SERIAL NUMBER of the engine referred to.

Starting and Operating New Engines

Careful breaking-in of a new engine will greatly increase its life and result in troublefree operation. A factory test is not sufficient to establish the polished bearing surfaces, which are so necessary to the proper performance and long life of an engine. These can only be obtained by running a new engine carefully and under reduced loads for a short time.

- Be sure the engine is filled to the proper level with a good quality engine oil.
- For proper procedures to follow when breaking-in a new engine, see 'Testing Rebuilt Engine'.

The various bearing surfaces in a new engine have not been glazed, as they will be with continued operation, and it is in this period of "running in" that special care must be exercised, otherwise the highly desired glaze will never be obtained. A new bearing surface that has once been damaged by carelessness will be ruined forever.

IMPORTANT SAFETY NOTICE

Proper repair is important to the safe and reliable operation of an engine. This Repair Manual outlines basic recommended procedures, some of which require special tools, devices or work methods.

Improper repair procedures can be dangerous and could result in injury or death.

READ AND UNDERSTAND ALL SAFETY PRECAUTIONS AND WARNINGS BEFORE PERFORMING REPAIRS ON THIS ENGINE

Warning labels have also been put on the engines to provide instructions and identify specific hazards which, if not heeded, could cause bodily injury or death to you or other persons. These labels identify hazards which may not be apparent to a trained mechanic. There are many potential hazards for an untrained mechanic and there is no way to label the engine against all such hazards. These warnings in the Repair Manual and on the engine are identified by this symbol:



Operations that may result only in engine damage are identified in the Repair Manual by this symbol:



Wis-Con Total Power cannot anticipate every possible circumstance that might involve a potential hazard; therefore, the warnings in this manual are not all inclusive. If a procedure, tool, device or work method not specifically recommended by Wis-Con Total Power is used, you must satisfy yourself that it is safe for you and others. You should also ensure that the engine will not be damaged or made unsafe by the procedures you choose.

IMPORTANT: The information, specifications and illustrations in this manual are based on information that was available at the time it was published. The specifications, torques, pressures of operation, measurements, adjustments, illustrations and other items can change at any time. These changes can affect the service given to the product. Get the complete and most current information before starting any job. For parts, service, or information, contact Wis-Con Total Power, Memphis, Tennessee.



WARNING

Most sub-systems used in conjunction with Wis-Con Total Power industrial engines including (but not limited to) radiators, hoses, fans, fuel tanks, fuel lines or other fuel system components, batteries, electrical connections or other electrical components, clutches, transmissions, hydraulic pumps and generators, are not supplied by Wis-Con Total Power. These items are provided by the manufacturer of the end item in which the engine is used.

Some of the dangers associated with servicing such items are generally mentioned in this manual; however, the appropriate handbooks and safety instructions provided by the manufacturer of the end item should always be consulted prior to the undertaking of any work on sub-systems attached to the engine, to avoid any hazards inherent to these sub-systems.



WARNING

Read and observe all individual safety warnings as you use this manual to operate, service or repair your engine.

Always exercise caution whenever working with an engine or any associated system.

Injuries may be caused by lack of care when working with, or near, moving parts, hot parts, pressurized systems, electrical equipment, or fuel systems.

Always wear eye and hearing protection when working on or near engines.

Improper attire such as loose clothing, ties, rings, soft shoes or bare feet could be hazardous and should be avoided when servicing engines.

Use or service of the engine (including the use of modified parts or materials) not in accordance with manufacturer's specifications could damage your engine or cause personal injury.



WARNING

Some equipment and materials used in the overhaul or maintenance of an engine such as machine tools, electrical equipment, compressed air, solvents, gasoline or other fuels may be dangerous and can cause injury. Always observe safety precautions.

SAFETY PRECAUTIONS

- Never fill fuel tank while engine is running or hot; avoid the possibility of spilled fuel causing a fire.
- Always refuel slowly to avoid spillage.
- When starting engine, maintain a safe distance from moving parts of equipment.
- Do not start engine with clutch engaged.
- Do not spin hand crank when starting. Keep cranking components clean and free from conditions which might cause the crank jaw to bind and not release properly. Oil periodically to prevent rust.
- Never run engine with governor disconnected, or operate at speeds in excess of 2800 R.P.M. load.
- Do not operate engine in a closed building unless the exhaust is piped outside. This exhaust contains carbon monoxide, a poisonous, odorless and invisible gas, which if breathed causes serious illness and possible death.
- Never make adjustments on machinery while it is connected to the engine, without first removing the ignition cable from the spark plug. Turning the machinery over by hand during adjusting or cleaning might start the engine and machinery with it, causing serious injury to the operator.
- Precaution is the best insurance against accidents.

*Keep this book handy at all times,
familiarize yourself with the operating instructions.*

Model VH4D

3-1/4" Bore — 3-1/4" Stroke 107.7 cu. in. Displacement

CONTENTS

Air Cleaners and Pre-Cleaner	10	Horsepower	7
Battery Ignition — Wiring and Timing Diagram	13	Ignition Switch	9
Carburetor Adjustment	11	Ignition System	7
Carburetor Service	34	Illustration of Engine and Power Unit	4
Walbro Model LUB	38	Lubrication	7
Zenith Model 87A8	34	Lubrication System	7
Zenith Model 68-7	36	Lubrication System — Illustration	6
Charging System	15	Magneto Breaker Point Adjustment	11
Clutch	24	Magneto Ignition Spark	11
Clutch Adjustment	25	Magneto Service	40
Clutch Reduction Unit	25	Fairbanks-Morse type FM-X4B7A	41
Compression — Restoring	15	Wico Model XHG-4	40
Cooling	7	Magneto Timing Diagram	13
Disassembly and Reassembly	18	Magneto Timing	12
Air Shrouding	18	Neon Lamp Timing	14
Camshaft	23	Oil Filter	10
Camshaft Gear	20	Oil — Grade of	8
Carburetor and Manifold	19	Oil Pressure	8
Crankshaft (End Play)	23	Overheating, Keep Engine Clean	15
Cylinder Block	22	Reduction Gears	25
Cylinder Head	19	Rotation	7
Flywheel	18	Safety Notice	ii-iii
Fuel Tank	19	Safety Precautions	2
Gear Cover	19	Safety Switch — High Temperature	15
Idle Gear and Shaft	20	Solid State Ignition Distributors	15, 42-43
Oil Pan	20	Spark Plugs	15
Oil Pump	20	Starting and Operating Instructions	7
Piston, Ring and Rod Clearance Chart	22	Starting and Operating New Engines	i
Piston Rings	21	Starting Procedure	9
Pistons and Connecting Rods	20	Stopping Engine — Vapor Lock and Dieseling	9
Valves and Seat Inserts	22	Storage of Engine for Winter	26
Distributor — Battery Ignition	12	Testing Rebuilt Engine	18
Distributor and Generator Maintenance	15	Troubles — Causes and Remedies	16
Distributor Timing	13	Backfiring Through Carburetor	18
Electrical Wiring Diagram	13	Compression	17
Engine Sectional Views	5	Ignition	17
Firing Order	12	Knocking	17
Flywheel Alternator	28-33	Missing	17
Fuel	8	Overheating	17
Fuel Pump and Priming	8	Starting Difficulties	16
Fuel Pump Service	27	Stops	17
Fuel Strainer	10	Surging or Galloping	17
General Information and Design	7	Valves — Grinding and Tolerances	22
Governor Adjustment	24	Valve Tappets	23
Governor — Operation	23	Warm-Up Period — Overspeeding	9

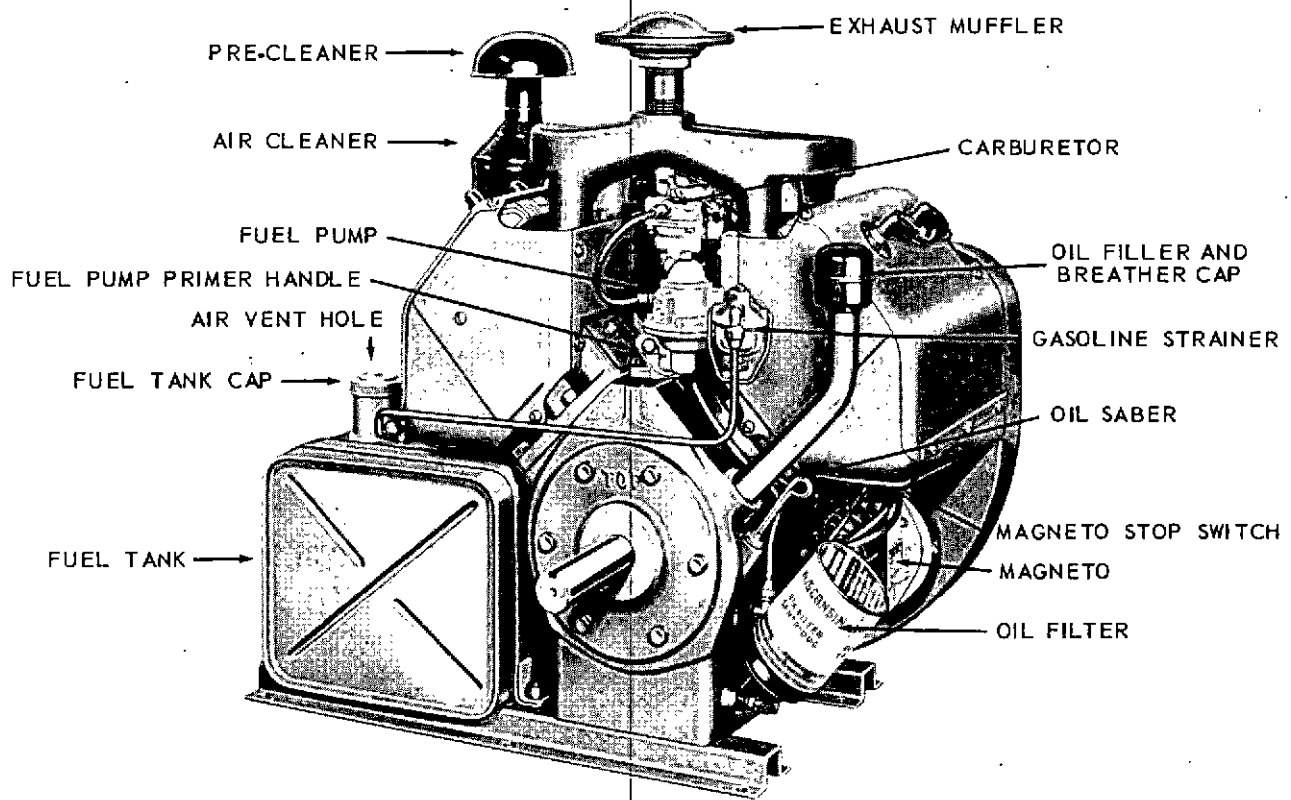

TAKE-OFF (Side Mount Tank) VIEW OF ENGINE

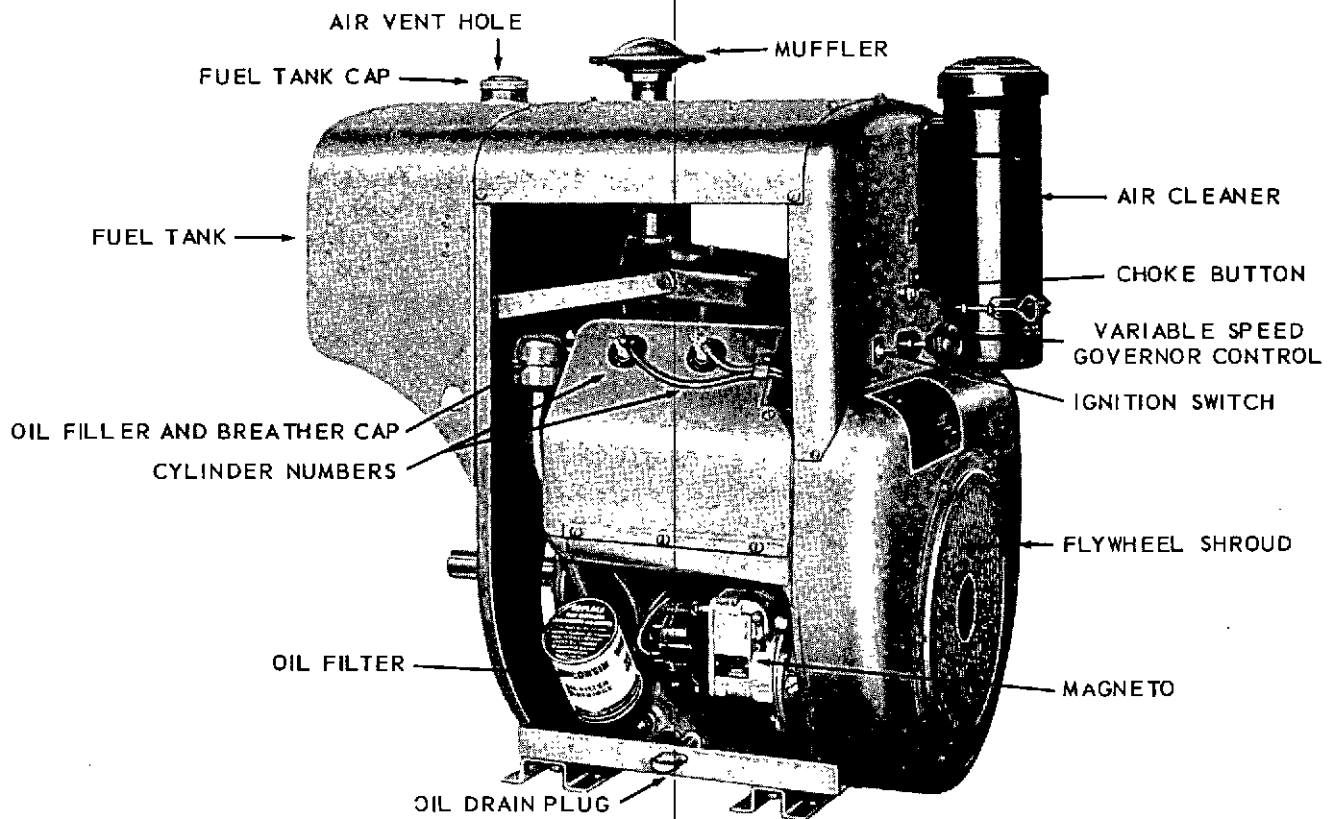

POWER UNIT FAN END VIEW OF ENGINE

Fig. 1

MODEL VH4D OPEN ENGINE AND POWER UNIT

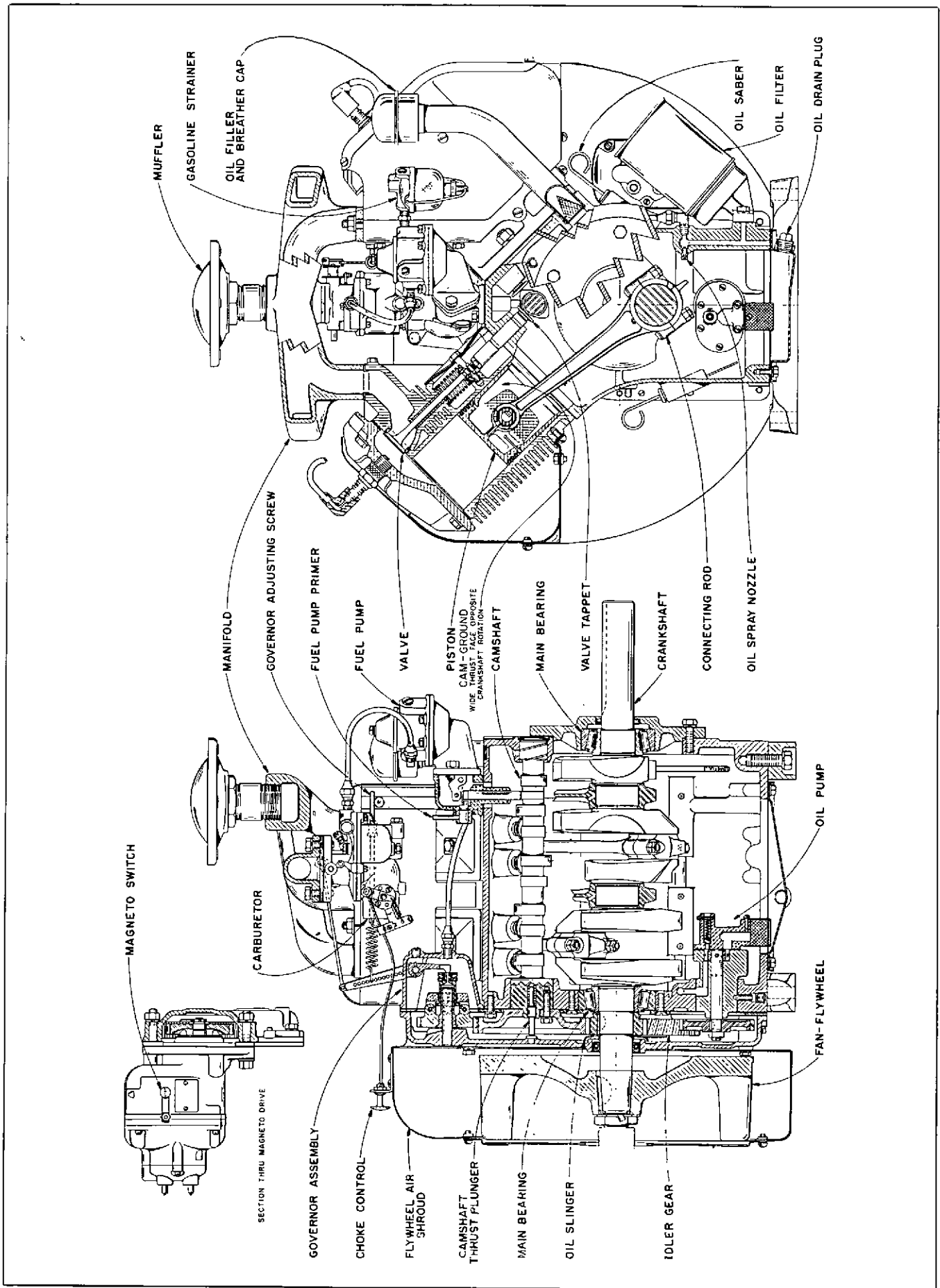
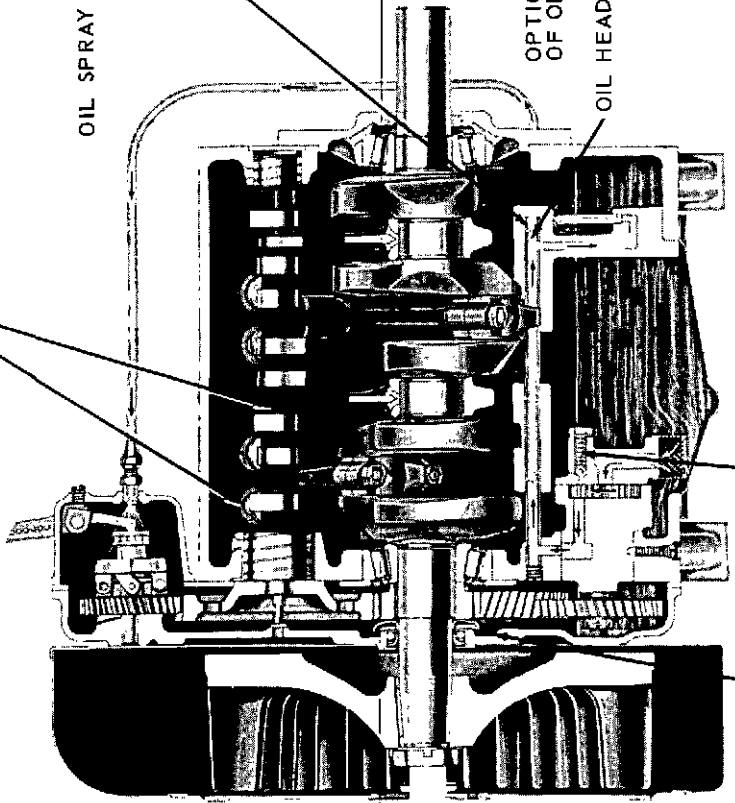
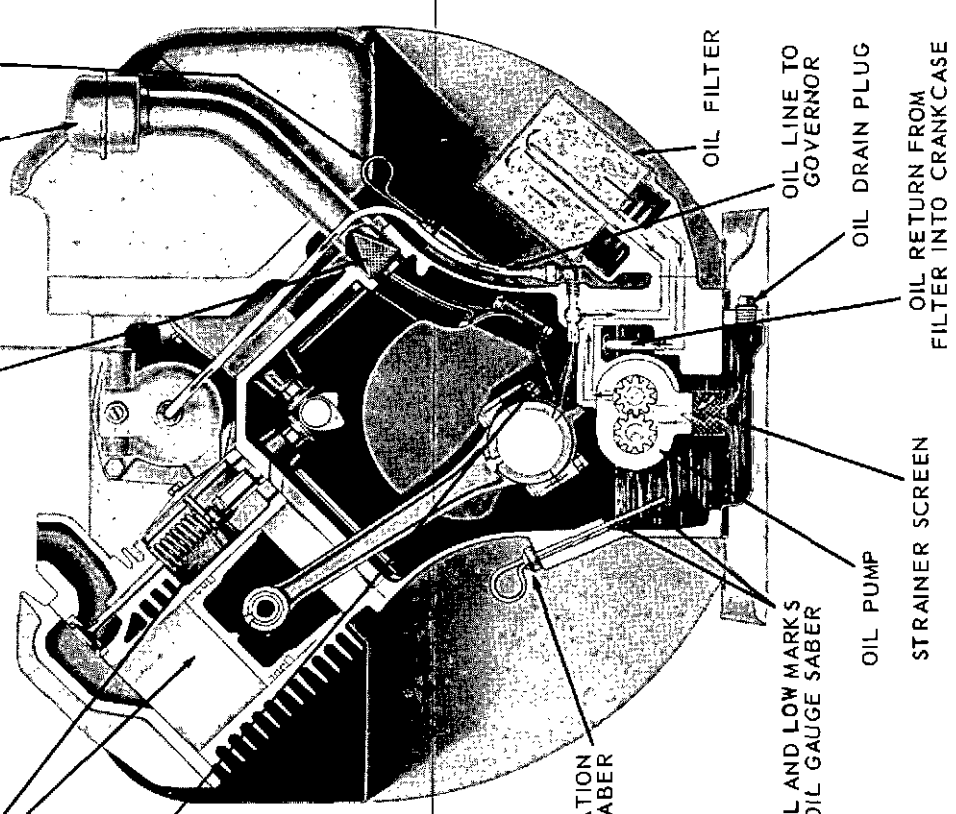

Fig. 2
 CROSS SECTION OF ENGINE MODEL VH4D

NOTE:
 CYLINDERS, RINGS, PISTONS, PINS, TAPPETS, VALVES,
 CAMSHAFT, BEARINGS AND ETC. ARE LUBRICATED BY
 THE OIL SPRAY OR MIST THROWN OFF THE CONNECT-
 ING RODS AND CRANKSHAFT.



WITH ENGINE AT OPERATING TEMPERATURE, OIL PRESSURE
 IN HEADER WILL BE APPROXIMATELY 5 POUNDS. AN OIL
 PRESSURE GAUGE IS NOT REQUIRED.

Fig. 3
 LUBRICATION SYSTEM

GENERAL INFORMATION and DESIGN

Wisconsin engines are of the *four cycle type*, in which each of the four operations of *intake, compression, expansion and exhaust* requires a complete stroke. This gives one power stroke per cylinder for each two revolutions of the crankshaft.

COOLING

Cooling is accomplished by a flow of air, circulated over the cylinders and heads of the engine, by a combination fan-flywheel encased in a sheet metal shroud. The air is divided and directed by ducts and baffle plates to insure uniform cooling of all parts.

Never operate an engine with any part of the shrouding removed - this will retard air cooling.

Keep the cylinder and head fins free from dirt and chaff. Improper circulation of cooling air will cause engine to overheat.

CARBURETOR

The proper combustible mixture of gasoline and air is furnished by a balanced carburetor, giving correct fuel to air ratios for all speeds and loads.

IGNITION SYSTEM

The spark for ignition of the fuel mixture is furnished by a high tension magneto driven off the timing gears at crankshaft speed. The magneto distributor rotor turns at half-engine speed. The magneto is fitted with an impulse coupling, which makes possible a powerful spark for easy starting. Also, the impulse coupling automatically retards the spark for starting, thus eliminating possible kick back from engine while cranking.

Battery ignition (12 volt); distributor is furnished in place of magneto on engines equipped with flywheel alternator or belt driven generator. See Pages 12-15.

LUBRICATION SYSTEM (Fig. 3)

A gear type pump supplies oil to four nozzles which direct oil streams against fins on the connecting rod caps. Part of the oil enters the rod bearing through holes in the rods, and the balance of the oil forms a spray or mist which lubricates the cylinder walls and other internal parts of the engine. An external oil line from the oil header tube in the crankcase lubricates the governor and gear train.

GOVERNOR

A governor of the centrifugal flyweight type maintains the engine speed by varying the throttle opening to suit the load imposed upon the engine. These engines are equipped with either a *fixed speed* governor, a *variable speed control* to regulate the governed speed of the engine, or an *idle control*.

ROTATION

The rotation of the crankshaft is clockwise when viewing the flywheel or cranking end of the engine. This gives *counter-clockwise rotation* when viewing

R.P.M.	HORSEPOWER
1400	17.2
1600	20.0
1800	22.5
2000	24.7
2200	26.5
2400	28.0
2600	29.2
2800	30.0

the power take-off end of the crankshaft. The flywheel end of the engine is designated the *front end*, and the power take-off end, the *rear end* of the engine.

HORSEPOWER

Horsepower specified in the accompanying chart is for an atmospheric temperature of 60° Fahrenheit at sea level and at a Barometric pressure of 29.92 inches of mercury.

For each inch lower the Barometric pressure drops, there will be a loss in horsepower of 3½%.

For each 10° temperature rise there will be a reduction in horsepower of 1%.

For each 1000 ft. altitude above sea level there will be a reduction in horsepower of 3½%.

The friction in new engines cannot be reduced to the ultimate minimum during the regular block test, but engines are guaranteed to develop at least 85 per cent of maximum power when shipped from the factory. The power will increase as friction is reduced during the first few days of operation. The engine will develop at least 95% of maximum horsepower when friction is reduced to a minimum.

For continuous operation, allow 20% of horsepower shown as a safety factor.

STARTING and OPERATING INSTRUCTIONS

Engines that are enclosed in a sheet metal house, as shown in bottom view of *Fig. 1*, are called *power units*. Others are furnished without a house, as shown in top view of *Fig. 1*, and are called *open engines*.

On engines with a house, the side doors must always be removed when operating.

This is necessary for circulating sufficient air for cooling the engine.

LUBRICATION

Before starting a new engine, fill the oil base with good "gasoline engine" oil, as specified in the "Grade of Oil" chart. Fill through the breather tube shown in *Fig. 3*, with 4 quarts of oil.

For *run-in of new engines*, use same oil as recommended in *Grade of Oil Chart*.

After the engine has been run for a short time, the oil lines and oil filter will have been filled with oil. Shut

GRADE OF OIL

SEASON OR TEMPERATURE		GRADE OF OIL
Spring, Summer or Fall + 120°F to + 40°F		SAE 30
Winter + 40°F to + 15°F + 15°F to 0°F Below Zero		SAE 20-20W SAE 10W SAE 5W-20
Use Oils classified as Service SE, SF, SG or CC		
Crankcase Capacity	New engine	4 Qts.
	Oil and filter change	4 Qts.
	Less - filter or filter change	3½ Qts.

off the engine and check the oil level by means of *dip stick* (oil gauge saber). If necessary, add enough oil to bring level up to the *full mark*. The standard dip stick location is below the oil filler-breather tube, but can be located on starting motor side upon request.

Use only high-grade highly refined oils, corresponding in body to the S. A. E. (Society of Automotive Engineers) Viscosity Numbers listed in *Grade of Oil Chart*.

SERVICE CLASSIFICATION OF OIL

In addition to the S.A.E. Viscosity grades, oils are also classified according to severity of engine service. Use oils classified by the American Petroleum Institute as **Service SE, SF or SG**. These types of oil are for engines performing under unfavorable or severe operating conditions such as: high speeds, constant starting and stopping, operating in extreme high or low temperatures and excessive idling.

Follow summer recommendations in winter if engine is housed in warm building.

Check oil level every 8 hours of operation.

The old oil should be drained and fresh oil added after every 50 hours of operation.

To drain oil, remove drain plug illustrated in *Fig. 3*. Oil should be drained while engine is hot, as it will then flow more freely.

OIL PRESSURE

At engine operating temperature, the oil pressure will be about 4 to 5 pounds per square inch, and due to this low pressure system, an oil pressure gauge is not required. When the engine is cold the pressure will be higher, and a relief valve is fitted to the oil pump so that under these conditions the maximum pressure will be limited to 15 pounds.

FUEL

These engines can be furnished with either a gravity feed tank mounted above the carburetor fuel level, a side mount tank, or tank mounted below the engine. In the latter two cases, a fuel pump is furnished.

The fuel tank should be filled with a *good quality* gasoline free from dirt and water. The capacity of the

tank is approximately 6 gallons. Some of the poorer grades of gasoline contain gum which will deposit on valve stems, piston rings, and in the various small passages in the carburetor, causing serious trouble in operating and in fact might prevent the engine from operating at all.

Use only reputable, well known brands of Unleaded gasoline.

The gasoline should have an octane rating of at least 87. Low octane gasoline will cause the engine to detonate, or knock, and if operation is continued under this condition, cylinders will score, valves will burn, pistons and bearings will be damaged, etc.

Be sure that air vent in tank cap is not plugged with dirt, as this would prevent fuel from flowing to the carburetor.

FUEL PUMP and PRIMING (Fig. 4)

The diaphragm type fuel pump, furnished on engines with side mount or underslung fuel tanks, is actuated by an eccentric on the camshaft, as illustrated in cross section of engine, *Fig. 2*.

Hand Primer for *hand crank engine* is an accessory furnished only upon request, and is a necessary function when starting a new engine for the first time, or when engine has been out of operation for a period of time. Gravity feed and electric start engines do not require hand priming.

When priming, a distinct resistance of the fuel pump diaphragm should be felt when moving the hand lever up and down. If this does not occur, the engine should be turned over one revolution so that the fuel pump drive cam will be rotated from its upper position which prevents movement of the pump rocker arm.

Assuming the gasoline strainer is empty, approximately 25 strokes of the primer lever are required to fill the bowl. See *Fig. 4*. After strainer bowl is full, an additional 5 to 10 strokes are required to fill the carburetor bowl. When carburetor is full the hand primer lever will move more easily.

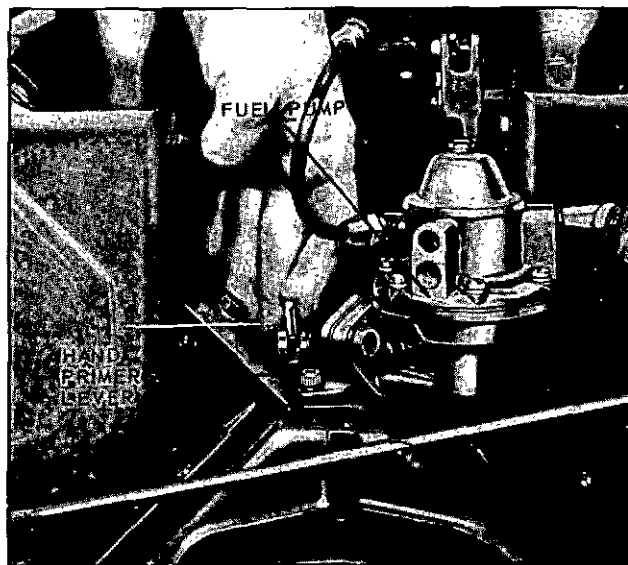

Fig. 4

IGNITION SWITCH

Magneto ignition is standard on these engines, with a lever type switch on the side of the magneto, which is always in the **on** or running position, except when depressed for stopping the engine. See top view of Fig. 1.

On power unit engines, a push button ignition switch is mounted on the outside of the house panel at the flywheel end. See bottom view of Fig. 1. When starting engine, the ignition switch button is **pulled out**. To stop, **push in**. This will apply to both **magneto** and **battery ignition** systems.

STARTING



WARNING

Maintain a safe distance from moving parts of equipment. Know how to stop the engine quickly in case of emergency.



WARNING

Do not operate engine in a closed building unless it is properly ventilated.

STARTING PROCEDURE

1. Check crankcase oil level and gasoline supply. Open fuel shut-off valve in fuel strainer or tank.
2. Disengage clutch, if furnished.
3. Pull variable speed control 'T' handle out about half-way and lock in place. With a two speed control, start in full load position - idle after engine starts.
4. Close choke by pulling choke button to extreme out position.
5. Pull out ignition switch button if tag reads **To Stop Push In'**, or, turn ignition switch to **'on'** position.
6. Depress starter switch to start engine, or, turn switch to **'start'** position.

IMPORTANT

Do not crank engine for more than 30 seconds at a time if engine fails to start, wait about 2 minutes between cranking periods to prevent starter from over-heating.

7. After engine starts, push choke button in gradually as required for smooth running. Choke must be completely open (button in) when engine is warmed up.

If flooding should occur, open choke fully by pushing choke button in and continue cranking. Less choking is necessary in warm weather or when engine is warm, than when cold.

WARM-UP PERIOD

The engine should be allowed to warm up to operating temperature before load is applied. This requires only a few

minutes of running at moderate speed. **Racing an engine or gunning it**, to hurry the warm-up period, **is very destructive** to the polished wearing surfaces on pistons, rings, cylinders, bearings, etc., as the proper oil film on these various surfaces cannot be established until the oil has warmed up and become sufficiently fluid. This is especially important on new engines and in cool weather.

Racing an engine by disconnecting the governor, or by doing anything to interfere with the governor controlled engine speed, **is extremely dangerous**. The governor is provided as a means for controlling the engine speed to suit the load applied, and also as a safety measure to guard against excessive speeds, which measure to guard against excessive speeds, which not only overstrain all working parts, but which which not only overstrain all working parts, but which might cause wrecking of the engine and possible injury to bystanders.

All parts of the engine are designed to safely withstand any speeds which might normally be required, but it must be remembered that the stresses set up in rotating parts, increase with the square of the speed. That means that if the speed is doubled the stressed will be quadrupled; and if the speeds are trebled, the stresses will be nine times as great.

Strict adherence to the above instructions cannot be too strongly urged, and greatly increased engine life will result as a reward for these easily applied recommendations.

STOPPING ENGINE

Magneto ignition engines, less house, have a lever type stop switch on the side of the magneto. On these, **to stop engine**, depress lever and **hold down until engine stops**.

Power units and battery ignition engines, are furnished with an ignition switch, **"To Stop Push In"**.

If the engine has been running hard and is hot, do not stop it abruptly from full load, but remove the load and allow engine to run idle at 1000 to 1200 R.P.M. for three to five minutes. This will reduce the internal temperature of the engine much faster, minimize valve warping, and of course the external temperature, including the manifold and carburetor will also reduce faster, due to air circulation from the flywheel.

Two main troubles resulting from abruptly shutting off a hot engine are **vapor lock** and **dieseling**. Vapor lock will prevent the flow of fuel in the fuel lines and carburetor passages, which will result in hard starting. This can be overcome by choking the engine when cranking or waiting until the engine has cooled off sufficiently to overcome the vapor lock.

Dieseling, is caused by the carbon deposits in the cylinder head being heated up to such an extent that they continue to fire the engine and keep it running after the ignition has been shut off. By idling the engine, as previously mentioned, the carbon deposits cool off, break up and will blow out through the exhaust.

MAINTENANCE

OIL FILTER

A *by-pass* type oil filter is furnished on these engines, as shown in *Fig. 3*, except in a few cases where the use of other accessories prevents the mounting of an oil filter. The oil *filtering cartridge should be replaced after every other oil change*. If operating conditions are *extremely dusty*, replace cartridge after *every oil change*.

AIR CLEANERS

The air cleaner is an essential accessory, filtering the air entering the carburetor and preventing abrasive dirt from entering the engine and wearing out valves and piston rings in a very short time.

The air cleaner must be serviced frequently, depending on the dust conditions where engine is operated. Check hose connections for leaks or breaks; replace all broken or damaged hose clamps.

Excessive smoke or loss of power are good indications the air cleaner requires attention.

The *oil bath* type air cleaner, illustrated in *Fig. 5* is standard equipment on power units. On open engines, the oil bath air filter furnished is illustrated in *Fig. 6*. A *dry element air cleaner* is optionally available for both power unit and open engine.

OIL BATH AIR CLEANER (Fig. 5)

Service daily or twice a day; if engine is operating in very dusty conditions. *Once each week*; in comparatively clean conditions.

Remove oil cup from bottom of air cleaner and clean thoroughly. Add fresh oil to the *level line* indicated on cup, using the same grade oil as used in engine crankcase.

Operating the engine under dusty conditions without oil in the air cleaner or with dirty oil, may wear out cylinders, pistons, rings and bearings in a few days time, and result in costly repairs.

Once a year; or oftener in very dusty conditions, the air cleaner should be removed from the engine and the element, which is not removable, should be washed in a solvent to clean out accumulated dust and dirt.

DRY ELEMENT AIR CLEANER

Service daily; squeeze rubber dust unloader once or twice a day to check for possible obstruction. If engine is operating in very dusty conditions, remove cartridge and shake out accumulated dirt.

Once each week; the filtering cartridge should be taken out and either dry-cleaned with compressed air or washed by repeated dipping for several minutes in a solution of lukewarm water and a mild *non-sudsing* detergent. Rinse in cold water from the inside out and allow to dry overnight before installing.

Do not use gasoline, kerosene or solvent for cleaning. - Do not oil element.



Fig. 5

After ten washings or one year of service, whichever comes first, replace cartridge.

PRE-CLEANER (Fig. 6)

The collector type pre-cleaner, mounted to the top of the air cleaner, removes the larger dirt and dust particles before the air reaches the main air cleaner.

Daily; clean bowl of accumulated dust and dirt. *Do not use oil or water in pre-cleaner. This must be kept dry.*

FUEL STRAINER (Fig. 7)

A fuel strainer is very necessary to prevent sediment, dirt and water from entering the carburetor and causing trouble or even complete stoppage of the engine. The strainer has a glass bowl and should be inspected frequently and cleaned if dirt or water are present. To remove bowl, first shut off fuel valve, then loosen the knurled nut below bowl and swing the wire bail to one side. After cleaning bowl and screen, reassemble the parts, being sure the gasket

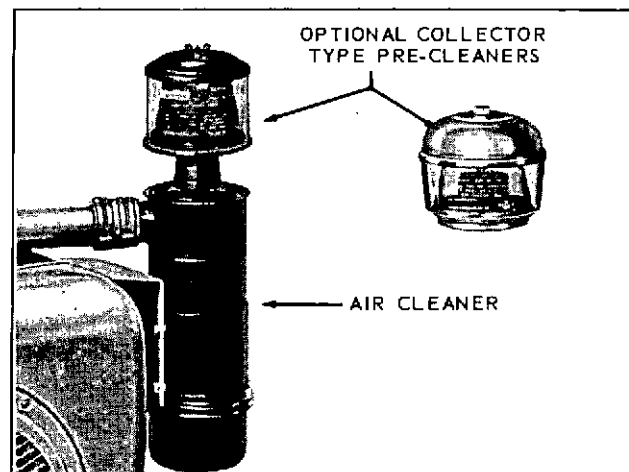

Fig. 6

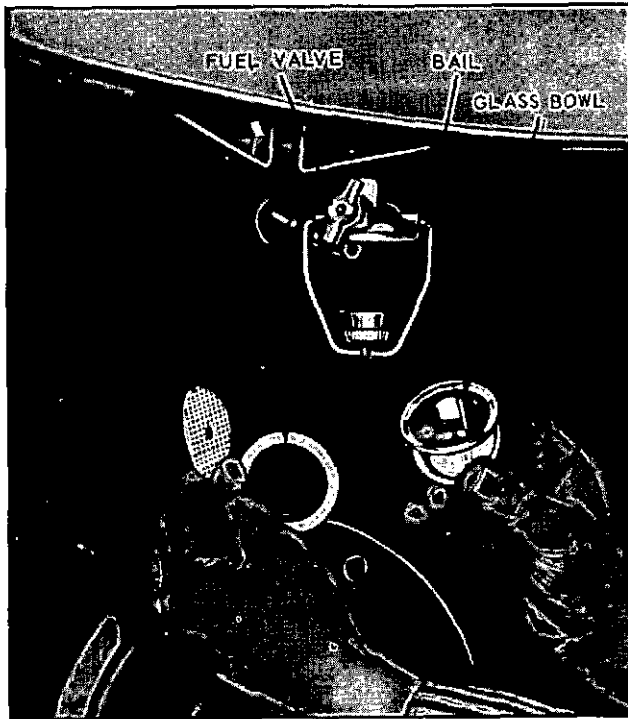

Fig. 7

is in good condition; otherwise use a new gasket. See Fig. 7, which shows the strainer mounted to the fuel tank of a power unit. On open engines, the strainer is mounted to the inlet of the fuel pump.

CARBURETOR ADJUSTMENT

The main metering jet in the carburetor is of the fixed type, that is, it requires no adjustment. The idle needle should be adjusted for best low speed operation, while carburetor throttle is closed by hand. For illustrations and more information, see Carburetor Manufacturer's Instruction Bulletin in the back of this manual.

MAGNETO BREAKER POINT ADJUSTMENT

Magnetos are properly adjusted before leaving factory. The *breaker points* on the Fairbanks-Morse magneto and on the Wico magneto should be $.015$ " at full separation. If the spark becomes weak after continued operation, it may be necessary to readjust these points. To do this first remove the end cover on the magneto. The crankshaft should then be rotated with the starting crank, (this also rotates the magneto), until the breaker points are wide open. The opening or gap should then be measured with a feeler gauge as shown in Fig. 8 and if necessary reset. To readjust points, first loosen the *locking screws* on the *contact plate* enough so that the plate can be moved. Insert the end of a small screw driver into the *adjusting slot* at the bottom of the *contact plate* and open or close the contacts by moving the plate until the proper opening is obtained. See Fig. 9. After tightening the locking screws, recheck breaker point gap to make sure it has not changed. If it is found that the breaker points have become rough, they should be smoothed with a breaker point file before the preceding adjustments are made. Replace magneto end cover carefully

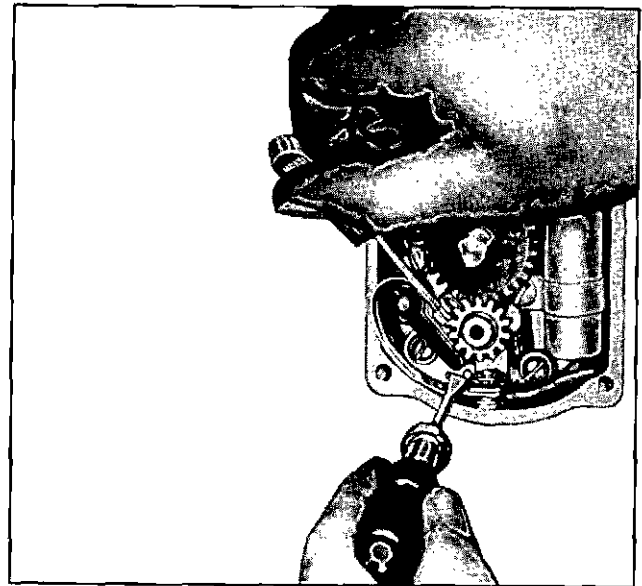
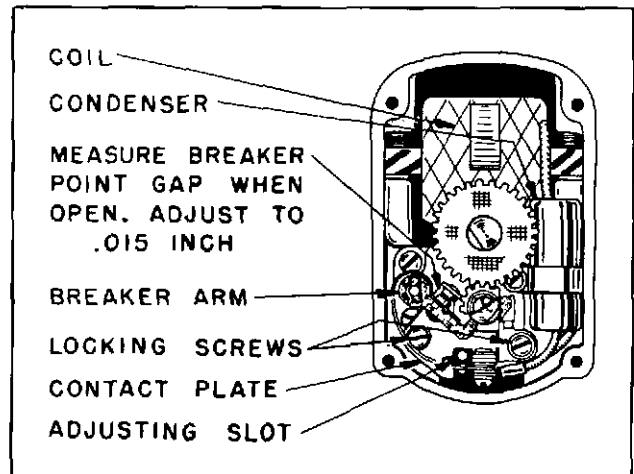

Fig. 8



OPEN END VIEW OF FAIRBANKS-MORSE MAGNETO
Fig. 9

so that it will seal properly. Do not force cover screws too tightly otherwise cover may crack. For further information, see Fairbanks-Morse or Wico Magneto Maintenance Manual in the back of this manual.

MAGNETO IGNITION SPARK

If difficulty is experienced in starting the engine or if engine misses firing, the strength of the ignition spark may be tested by disconnecting the No. 1 ignition cable from the spark plug and holding the terminal about 1/8 inch away from the air shroud or any other conveniently located metal part of the engine. If the ignition cables have a molded rubber insulated spark plug terminal at the end, as illustrated in Fig. 10, wedge a piece of bare wire up into the terminal and let one end of the wire extend out. Turn the engine over slowly by the starting crank two complete revolutions and watch for a strong spark discharge, which should occur during the cycle at the instant the impulse coupling on the magneto snaps. Repeat this check with each of the other ignition cables. If there is a weak spark, or none at all, check breaker point opening as mentioned in preceding paragraph under

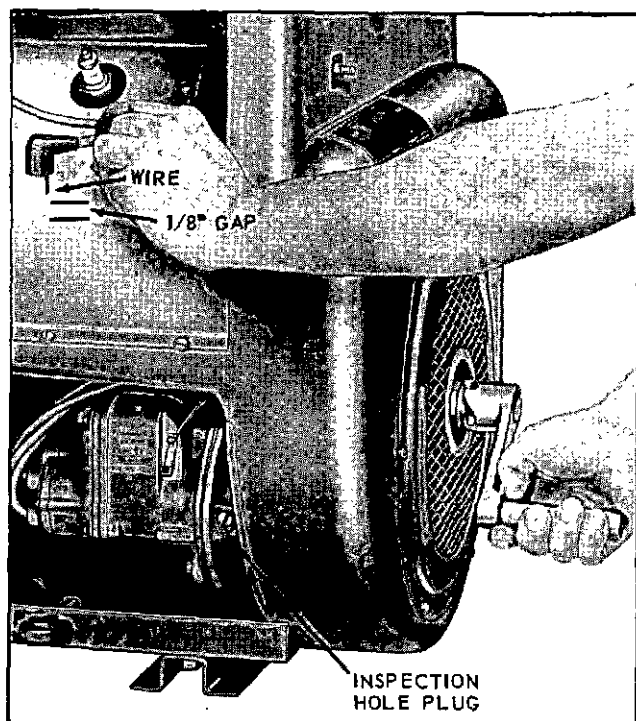

Fig. 10

"Magneto Breaker Point Adjustment". If this does not remedy the trouble, it may be necessary to install a new condenser. See Magneto Manufacturer's Maintenance Instructions in back of this manual.

FIRING ORDER

The firing order of the cylinders is 1-3-4-2, and the magneto and battery type distributor rotate at one-half engine speed, as is the case with conventional "in line" engines. The intervals between the firing of the cylinders is 180°. No. 1 cylinder is the one nearest to the flywheel in the left bank of cylinders, when viewed from the flywheel end of the engine. No. 3 cylinder is the other cylinder in this bank. No. 2 cylinder is the one nearest to the flywheel in the right bank of cylinders and No. 4 is the other cylinder in this bank. The cylinders are numbered from 1 to 4 on the air shroud near the spark plugs. The flywheel end of the engine is designated the front and the power take-off end, the rear of the engine.

MAGNETO TIMING

The proper spark advance is 23°. To check timing with a neon light, the running spark advance is indicated by a 3/8 inch slotted hole in the rim of the air intake screen, 68° left of the flywheel shroud vertical centerline, marked *VH*, or if screen is removed, time to the lower half of the 1/4 inch elongated hole on the face of flywheel shroud 23° below the centerline of No. 1 and No. 3 cylinders as illustrated in Fig. 11. The end of the 'X' marked vane should be whitened with chalk or paint for this operation.

To Time Magneto to Engine: Remove air intake screen to expose timing marks on both flywheel and shroud. See Magneto Timing Diagram, Fig. 11.

Next, remove the spark plug from No. 1 cylinder and slowly turn the flywheel clockwise, at the same time holding a finger over the spark plug hole, so that the compression stroke can be determined from the air blowing out of the hole.

The flywheel is marked with the letters 'DC' near one of the air circulating vanes. This vane is further identified by an 'X' mark cast on the end. See Fig. 11. When the air blows out of the No. 1 spark plug hole, continue turning the crank until the edge of the marked vane on flywheel is on line with the mark on the vertical centerline of the shroud as shown on Fig. 11. Leave flywheel in this position. At this point the keyway for mounting the flywheel is also on top. Reassemble spark plug.

Next, remove the inspection hole plug from the magneto timing opening, located in the gear cover as shown in Fig. 10.

Assuming that the magneto has been removed from the engine, the following procedure should be followed before remounting.

The Number 1 cylinder firing position of the magneto must be determined. Insert the ignition cable into the No. 1 tower terminal of the magneto end cap and hold the spark plug terminal at the other end, about 1/8" away from the magneto body. Turn the magneto gear in a clockwise rotation, tripping the impulse coupling, until the No. 1 terminal sparks, then hold the gear in this position. Mount the magneto to the engine, meshing the gears so that when the magneto is in place, the gear tooth marked with an 'X' will be visible through the lower half of the inspection hole in the gear cover, as shown in Timing Diagram, Fig. 11. Tighten the nut and capscrew for mounting the magneto to the gear cover, making sure the magneto flange gasket is in place.

The No. 1 terminal is identified on the magneto cap. The terminals follow the proper firing order of 1-3-4-2 in a clockwise direction viewing the cap end. The leads from the magneto should be connected to spark plugs of corresponding numbers.

No. 1 cylinder is the cylinder nearest the fan-flywheel of the engine in the left bank and No. 3 cylinder is the other cylinder in that bank. No. 2 cylinder is across the engine from No. 1 and No. 4 is across from No. 3.

When the magneto is properly timed the impulse coupling will snap when the 'DC' and 'X' marked vane of the flywheel, line up with the mark on the flywheel shroud which indicate the centerline of the No. 1 and 3 cylinders. This can be checked by turning crankshaft over slowly by means of a hand crank. The impulse will also snap every 180° of flywheel rotation thereafter.

DISTRIBUTOR - BATTERY IGNITION

On engines equipped with Flywheel Alternator or belt driven alternator, battery ignition is used in place of magneto ignition. The distributor is of the automatic advance type, and rotor turns at one-half engine speed in a counterclockwise direction.

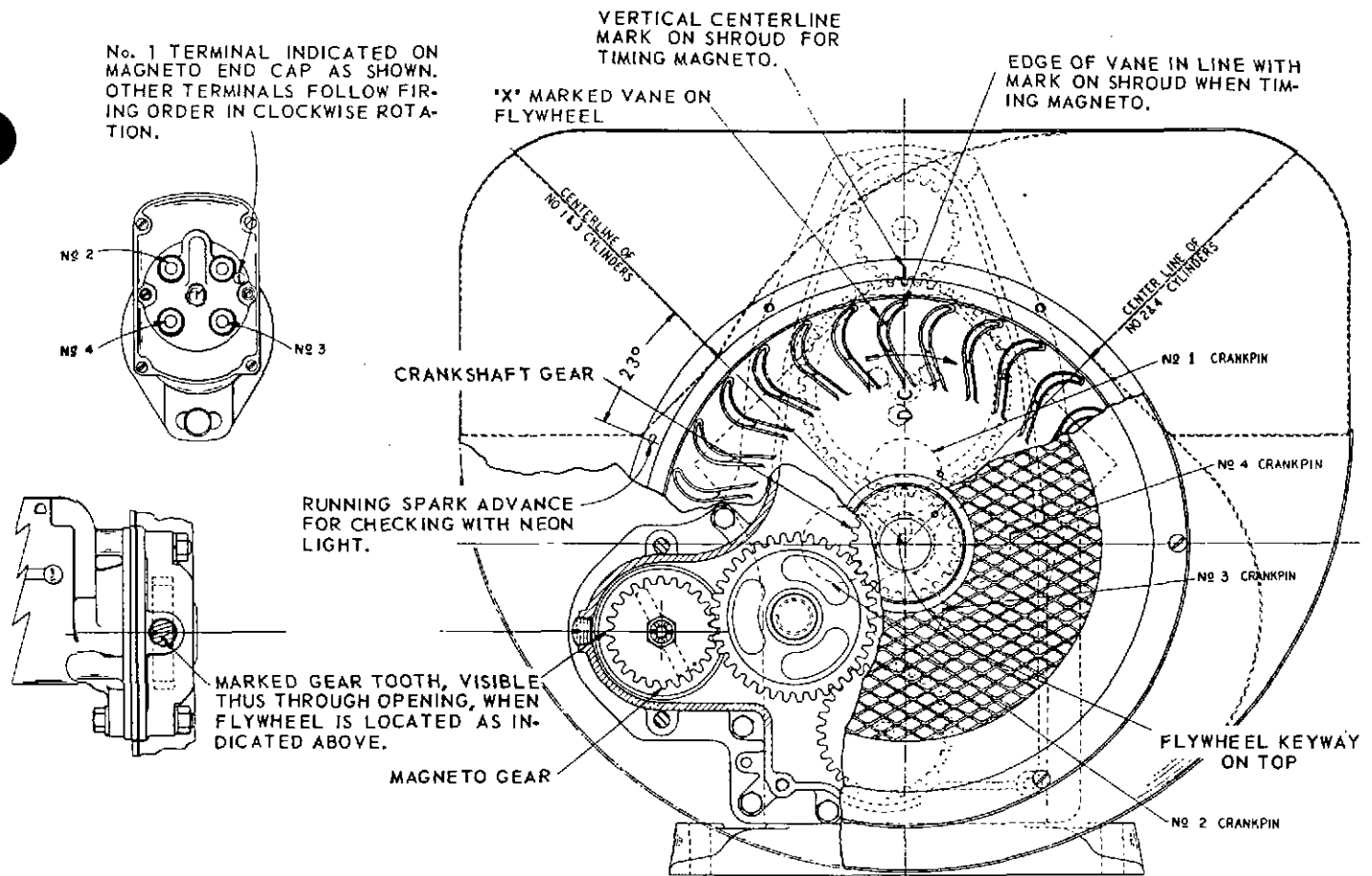

Fig. 11, MAGNETO TIMING DIAGRAM

The distributor is mounted to an adapter attached to the gear cover, or Top Mounted - attached to the governor housing.

The *spark advance* for normal speeds is 23°, the same as for magneto ignition. **Engine must be running at 2000 R.P.M. or over when adjusting spark advance.**

ELECTRICAL WIRING CIRCUITS

NOTE: Beginning with engine serial No. 3987113, the standard wiring circuits for all 12 volt electrical equipment is **negative ground polarity**, in place of the previously furnished positive ground. All 6 volt systems remain positive ground.

The Flywheel Alternator circuit illustrated in Fig. 12 always was and is a negative ground system. It replaces the previously furnished gear driven generator which was available both negative and positive ground.

Wiring diagram and service parts information for **obsolete** gear driven type generator can be obtained by writing to Wis-Con Total Power, Memphis, TN 38118.

DISTRIBUTOR TIMING

A slotted opening has been added to the rim of the flywheel screen to check **running spark advance** without

removing screen. To make a **stationary check** of the timing—remove the screen over the flywheel air intake opening by taking out the screws holding the screen in

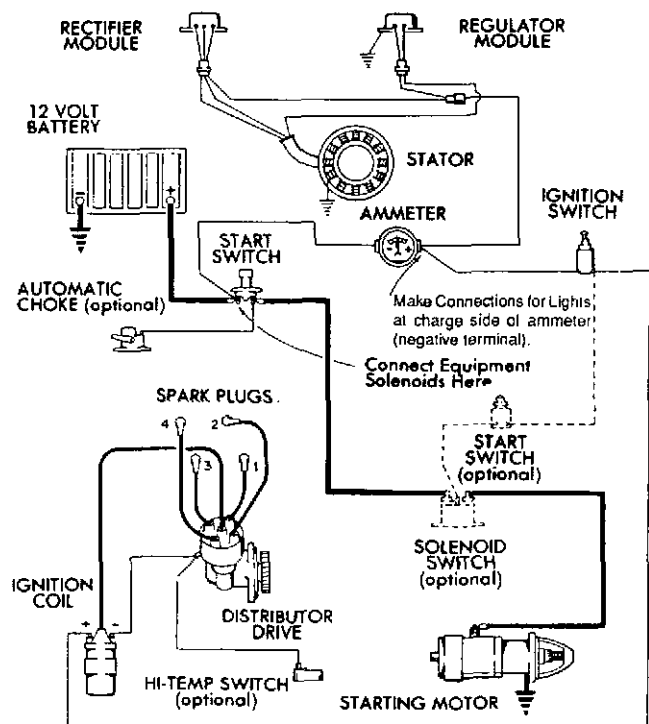

Fig. 12, WIRING DIAGRAM, 25amp Flywheel Alternator and Battery Ignition

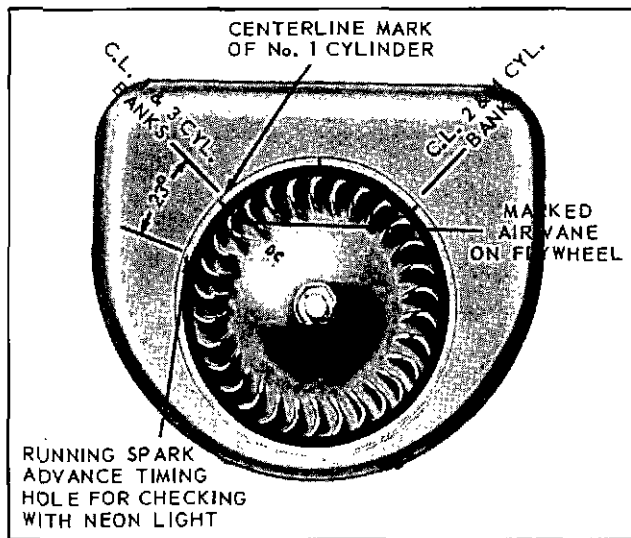

Fig. 13

place. This will expose the timing marks on the flywheel shroud, also the **vane** on flywheel, marked by an "X" and the letters "DC". See Fig. 13. Next, remove the spark plug from No. 1 cylinder and turn the engine over slowly by the starting crank, at the same time holding a finger over the spark plug hole, so that the compression stroke can be determined from the air blowing out of the hole.

Upon reaching the compression stroke, continue turning the starting crank until the leading edge of the **marked vane** on the flywheel is in line with the **centerline mark** on the flywheel shroud of the No. 1 cylinder. The No. 1 piston is on top dead center in the position shown in Fig. 13. Reassemble spark plug.

Remove the upper half of the distributor body by disengaging snap springs. The **centerline** of the **distributor rotor** should be in line with the **center** of the **notch** in the distributor housing. No. 1 cylinder is ready to fire in the retarded timing position, when the distributor rotor is in this position.

Assemble distributor with the **distributor rotor** in line with the **notch** in the distributor housing and the **primary terminal** pointing toward the generator **circuit breaker**. Be sure that the **advance arm lock screw** which is mounted to the **distributor clamp** is tight, as a manual spark advance is not used with these engines.

With the **advance arm clamp screw** loose, turn the distributor body slightly in a counterclockwise rotation so that the breaker points are firmly closed. Then turn the distributor body in a clockwise rotation until the breaker points are just **beginning to open**. At this point, a slight resistance can be felt as the breaker point cam strikes the breaker point arm. Tighten **advance arm clamp screw**. The No. 1 cylinder is now ready to fire in the retarded position, with the **centerline** of the **distributor rotor** in line with the **center** of the **notch** in the distributor body.

The breaker point gap should be .018 to .022 inches. This opening should be checked before the distributor body is set, otherwise any adjustment made to the breaker point opening will change the ignition advance. Replace distributor dust cover. If care is exercised in the above operations, the spark timing should be accurate enough for satisfactory starting, however, **checking spark advance with a neon lamp**, as described in 'Neon Lamp Timing', is necessary.

The four ignition cables from the distributor should be connected to the proper spark plugs. The cylinder shroud covers are marked for identification. The No. 1 terminal tower on the distributor body. The terminal sequence is 1 - 3 - 4 - 2 in a counterclockwise rotation.

NOTES

NEON LAMP TIMING

The engine should be timed to the 23° advanced position at not less than 2000 R.P.M.

The timing should be checked with a neon lamp connected in series with No.1 spark plug. Chalk or paint the end of the "X" marked vane on the flywheel, white. Then with the engine operating at 2000 R.P.M. or over, allow the flash from the neon lamp to illuminate the whitened vane. At the time of the flash, the leading edge of the vane should line up with the lower half of the **running spark advance timing hole** on the flywheel shroud, see Fig. 13. If it does not, the **advance arm clamp screw** should be loosened, and the distributor body turned slightly clockwise or counterclockwise, as required, until the **white flywheel vane** matches up with the lower half of the **advance timing hole**. Be sure **advance arm clamp screw** is then carefully tightened. If the engine is running below 2000 R.P.M. when timing, the automatic advance in the distributor will not be fully advanced and the inaccurate timing may cause serious damage to the engine when operating at high speeds. Mount flywheel screen if removed - use **slotted opening** without removing screen for running spark advance check only.

POINT TYPE IGNITION DISTRIBUTOR

The distributor breaker point gap should be .018 to .022 inches. To readjust breaker point gap, turn engine over by means of the starting crank until the distributor breaker arm **rubbing block** is on a high point of the cam. Loosen the **stationary contact locknut** and screw **fixed contact**, in or out, until correct gap is obtained. Tighten locknut and re-check gap.

SOLID STATE IGNITION DISTRIBUTORS

Many Wisconsin engines are now being equipped with a solid state ignition distributor. Detailed troubleshooting, repair and parts information can be found in the rear section of this manual.

CHARGING SYSTEM

Engines can be equipped with a **10 amp, 25 amp, or 30 amp flywheel alternator** system or a **37 amp belt driven alternator**. Instructions are located in the rear of this manual.

RESTORING COMPRESSION

In a new engine or one which has been out of operation for some time, oil may have drained off the cylinders so that compression will be weak, causing difficulty in starting. To remedy this condition, remove the spark plugs and pour about a fluid ounce of crankcase oil through the spark plug hole into each cylinder. Turn engine over several times with the hand crank to distribute oil over the cylinder walls. Assemble spark plugs and compression should be satisfactory.

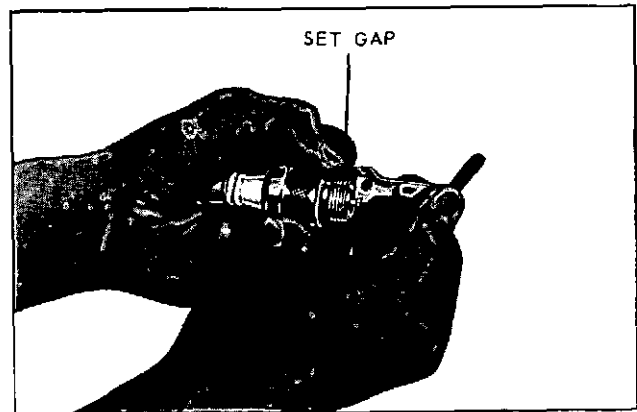

Fig. 16

SPARK PLUGS, Fig. 16

Incorrect gap, fouled or worn spark plug electrodes, will have an adverse affect on engine operation. Remove spark plugs periodically, clean, regap or replace if necessary. Thread size is 18 mm.

Spark plug gap - 0.030 of an inch.

Replacement plugs must be of the correct heat range, like Champion No. D-16J, AC No. C86 commercial. Tighten spark plugs, **25 to 30 foot pounds torque**.

HIGH TEMPERATURE SAFETY SWITCH

As a safety precaution against overheating, engines can be equipped with a high temperature switch mounted to the cylinder head at the **No. 4 spark plug**.

When cylinder head temperature becomes critically high, the safety switch will automatically stop the engine by shorting out the ignition system. A waiting period of about **10 minutes** will be required before the switch has cooled off sufficiently to re-start the engine. An overheated engine will score the cylinder walls, burn out connecting rod and crankshaft bearings, also warp pistons and valves. The cause of the overheating condition will have to be remedied before the engine is re-started. See *Engine Overheats* paragraph in *Troubles, Causes and Remedies* section. *Service Kit* is available - see parts list section.

KEEP ENGINE CLEAN - PREVENT OVERHEATING (Agricultural and Industrial Engines)

This engine is cooled by blasts of air which must be allowed to circulate all around the cylinders and cylinder heads to properly cool the engine and thereby keep it in good running condition. If **dust, dirt or chaff is allowed to collect in the cylinder shrouding or in the V between the cylinders**, it will retard the flow of air and cause the engine to overheat. Keep **flywheel screen** and **rotating screen** clean, so as not to restrict the intake of cooling air.

With reference to *Fig. 17*; follow the cleaning and maintenance instructions pointed out, to obtain trouble free and satisfactory engine performance.

1. Remove these covers frequently and clean out all dust, dirt and chaff. Be sure to replace covers.

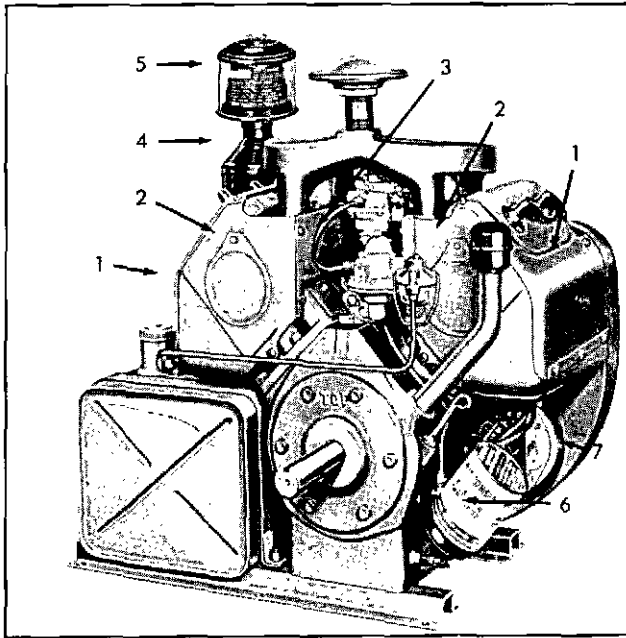

Fig. 17

2. Open these covers frequently and clean out all dust and chaff. Be sure to close covers.
3. Keep this space between cylinders free of dust and chaff.
4. Read instructions on this air cleaner regarding its care. This is important. The entire air cleaner should be removed from the engine at least once a year, and washed in a cleaning fluid to clean out dirt gathered in the back fire trap in the top part of the air cleaner.
5. Empty pre-cleaner of accumulated dust and dirt frequently. Do not use oil or water in pre-cleaner, this must be kept dry.
6. Replace this oil filter cartridge every other oil change. If operating conditions are extremely dusty replace cartridge every oil change. Be sure that your replacement is a Wisconsin Micro-Fine filter.
7. Do not allow shrouding to become damaged or badly dented as this will retard air flow.

Never operate engine with air shrouding removed. This will retard air cooling.

Always keep all parts of the engine clean. This will prolong engine life, and give more satisfactory operation.

Every 4 to 8 hours, depending on dust conditions, check air cleaner and change oil. See Page 10.

Every 8 hours check crankcase oil level. Keep filled to full mark on oil gauge sabre, but no more. See Fig. 3.

Every 50 hours drain crankcase and refill with fresh oil. See Lubrication, Pages 6 and 7.

TROUBLES CAUSES AND REMEDIES

Three prime requisites are essential to starting and

maintaining satisfactory operation of gasoline engines. They are:

1. **A proper fuel mixture** in the cylinder.
2. **Good compression** in the cylinder.
3. **Good spark, properly timed**, to ignite the mixture.

If all three of these conditions do not exist, the engine cannot be started. There are other factors which will contribute to hard starting; such as, too heavy a load for the engine to turn over at a low starting speed, a long exhaust pipe with high back pressure, etc. These conditions may affect the starting, but do not necessarily mean that the engine is improperly adjusted.

As a guide to locating any difficulties which might arise, the following causes are listed under the three headings: **Fuel Mixture, Compression, and Ignition.**

In each case, the causes of trouble are given in the order in which they are most apt to occur. In many cases the remedy is apparent, and in such cases no further remedies are suggested.

STARTING DIFFICULTIES

FUEL MIXTURE

No fuel in tank or fuel shut-off valve closed.

Fuel pump diaphragm worn out, so pump does not supply carburetor with fuel.

Carburetor not choked sufficiently, especially if engine is cold. See 'Choke', Page 9.

Water, dirt, or gum in gasoline interfering with free flow of fuel to carburetor.

Poor grade or stale gasoline that will not vaporize sufficiently to form the proper fuel mixture.

Carburetor flooded, caused by too much choking especially if engine is hot. See 'Choke', Page 9.

Dirt or gum holding float needle valve in carburetor open. This condition would be indicated if fuel continues to drip from carburetor with engine standing idle. Often tapping the float chamber of the carburetor very lightly with the handle of a screw driver or similar tool will remedy this trouble. Do not strike carburetor with any metal tools, it may cause serious damage. Also if the mixture in the cylinder, due to flooding, is too rich, starting may be accomplished by continued cranking, with the carburetor choke open.

If, due to flooding, too much fuel should have entered the cylinder in attempting to start the engine, the mixture will most likely be too rich to burn. In that case, the spark plugs should be removed from the cylinders and the engine then turned over several times with the starting crank, so the rich mixture will be blown out through the spark plug holes. The choke on the carburetor should of course be left open during this procedure. The plugs should then be replaced and starting tried again.

To test for clogged fuel line, loosen fuel line nut at carburetor slightly. If line is open, fuel should drip out at loosened nut.

COMPRESSION

Compression check with a commercial compression test gauge can show whether or not an engine has faulty compression. We do not consider it practical to publish a PSI compression figure because of the variables involved: engine condition, method of testing, and RPM of test. Our recommendation is that whatever gauge test is performed, a 10% variance between cylinders would indicate leaking rings, leaking valves or any of the following:

Cylinder dry due to engine having been out of use for some time. See *'Restoring Compression'*, Page 15.

Loose spark plugs or broken spark plug. In this case a hissing noise will be heard when cranking engine, due to escaping gas mixture on compression stroke.

Damaged cylinder head gasket or loose cylinder head. This will likewise cause hissing noise on compression stroke.

Valve stuck open due to carbon or gum on valve stem. To clean valve stems, see *'Valves'*, Page 22.

Valve tappets adjusted with insufficient clearance under valve stems. See *'Valve Tappets'*, Page 23.

Piston rings stuck in piston due to carbon accumulation. If rings are stuck very tight, this will necessitate removing piston and connecting rod assembly and cleaning parts. See *'Piston and Connecting Rod'* Page 21.

Scored cylinders. This will require reboring of the cylinders and fitting with new pistons and rings. If scored too severely, an entirely new cylinder block may be necessary.

IGNITION

See *'Magneto Ignition Spark'*, Page 11 or *'Distributor-Battery Ignition'*, Page 12: No spark may also be attributed to the following:

Ignition cable disconnected from magneto or spark plugs.

Broken ignition cables, causing short circuits.

Ignition cables wet or soaked.

Spark plug insulators broken.

Spark plugs wet or dirty.

Spark plug point gap wrong. See Page 15.

Condensation on spark plug electrodes.

Magneto or distributor breaker points pitted or fused.

Magneto or distributor breaker arm sticking.

Magneto or distributor condenser leaking or grounded.

Spark timing wrong. See *'Magneto Timing'*, Page 12, or *'Distributor-Battery Ignition'*, Page 12.

ENGINE MISSES

Spark plug gap incorrect. See Page 15.

Worn and leaking ignition cables.

Weak spark. See *'Magneto Ignition Spark'*, Page 11, or *'Distributor-Battery Ignition'*, Page 12.

Loose connections at ignition cable.

Magneto or distributor breaker points pitted or worn.

Water in gasoline.

Poor compression. See *'Compression'*, Page 17.

ENGINE SURGES OR GALLOPS

Carburetor flooding.

Governor spring hooked into wrong hole in lever. See *'Governor Adjustment'*, Page 24. Governor rod incorrectly adjusted. See *'Governor Adjustment'*, Page 24.

ENGINE STOPS

Fuel tank empty.

Water, dirt or gum in gasoline.

Gasoline vaporized in fuel lines due to excessive heat around engine (Vapor Lock). See *'Stopping Engine'*, Page 9.

Vapor lock in fuel lines or carburetor due to using winter gas (too volatile) in hot weather.

Air vent hole in fuel tank cap plugged. Engine scored or stuck due to lack of oil.

Ignition troubles. See *'Ignition'*, Page 17.

ENGINE OVERHEATS

Crankcase oil supply low. Replenish immediately.

Ignition spark timed wrong. See *'Magneto Timing'*, Page 12, or *'Distributor-Battery Ignition'*, Page 12.

Low grade of gasoline.

Engine overloaded.

Restricted cooling air circulation.

Part of air shroud removed from engine.

Dirt between cooling fins on cylinder or head.

Engine operated in confined space where cooling air is continually recirculated, consequently becoming too hot.

Carbon in engine.

Dirty or incorrect grade of crankcase oil.

Restricted exhaust.

Engine operated while detonating due to low octane gasoline or heavy load at low speed.

ENGINE KNOCKS

Poor grade of gasoline or of low octane rating. See *'Fuel'*, Page 8.

Engine operating under heavy load at low speed.

Carbon or lead deposits in cylinder head.

Spark advanced too far. See *'Magneto Timing'*, Page 12, or *'Distributor-Battery Ignition'*, Page 12.

Loose or burnt out connecting rod bearing.

Engine overheated due to causes under previous heading.

Worn or loose piston pin.

ENGINE BACKFIRES THROUGH CARBURETOR

Water or dirt in gasoline.

Engine cold.

Poor grade of gasoline.

Sticky inlet valves. See 'Valves', Page 22.

Overheated valves.

Spark plugs too hot. See 'Spark Plug', Page 15.

Hot carbon particles in engine.

DISASSEMBLY AND REASSEMBLY OF VH4D ENGINE

Engine repairs should be made only by a mechanic who has had experience in such work. When disassembling the engine, it is advisable to have several boxes available so that parts belonging to certain groups can be kept together, such as, for instance, the cylinder head screws, etc. Capscrews of various lengths are used in the engine, therefore great care must be exercised in reassembly so the right screw will be used in the various places, otherwise damage may result.

Tighten the capscrews and nuts of the manifolds, cylinder heads, gear cover, oil pan, connecting rods, cylinder blocks, main bearing plate and the spark plugs to the specified torque readings indicated in the following paragraphs of reassembly.

While the engine is partly or fully dismantled, all of the parts should be thoroughly cleaned. Remove all accumulated dirt between the fins.

If it is desired to disassemble the engine, the following order should be substantially adhered to. As disassembly progresses, the order may be altered somewhat if desired, as will be self-evident to the mechanic. Reassembly of the engine should be made in the reverse order.

TESTING REBUILT ENGINE

Proper *break-in* will lead to trouble-free operation and increased engine life. The factory test given to a new engine is not sufficient to establish the polished bearing surfaces which are so necessary for good performance and long engine life. There is no quick way to force the establishment of good bearing surfaces, and these can only be obtained by running a new engine carefully and under reduced speeds and loads for a short period of time. Run the engine for a half hour without load at low idle speed (1000 to 1200 R.P.M.). The speed should then be increased gradually, to engine operating r.p.m. still without load, for an additional two hours. If at all

possible, operate the engine at light loads for a period totaling about eight hours, before maximum load is applied.

ACCESSORIES

The air cleaner, oil filter, magneto, and if an electric starter and generator are used, these should be removed first.

Remove clutch or clutch reduction unit if engine is equipped with either of these accessories.

SHEET METAL HOUSE

On power units, remove the muffler and canopy first. Disconnect air cleaner, choke, governor control and instrument wires at the front house panel. The front panel can be removed as part of the flywheel shroud, as explained in the following paragraphs of disassembly.

FLYWHEEL

After the flywheel screen has been removed, drive out the starting crank pin in the crankshaft and remove the flywheel nut and washer.

The flywheel is mounted to a taper on the crankshaft. Take a firm hold on the flywheel fins, pull outward and at the same time strike the end of the crankshaft with a babbitt hammer, see Fig. 18. The flywheel will slide off the taper of the crankshaft. Do not use a hard hammer as it may ruin the crankshaft and bearings. When reassembling the flywheel, be sure the Woodruff key is in position on the shaft and that the keyway in the flywheel is lined up accurately with the key.

AIR SHROUDING

To disassemble air shrouding, refer to Fig. 19. First remove cylinder head covers and the screws mount-

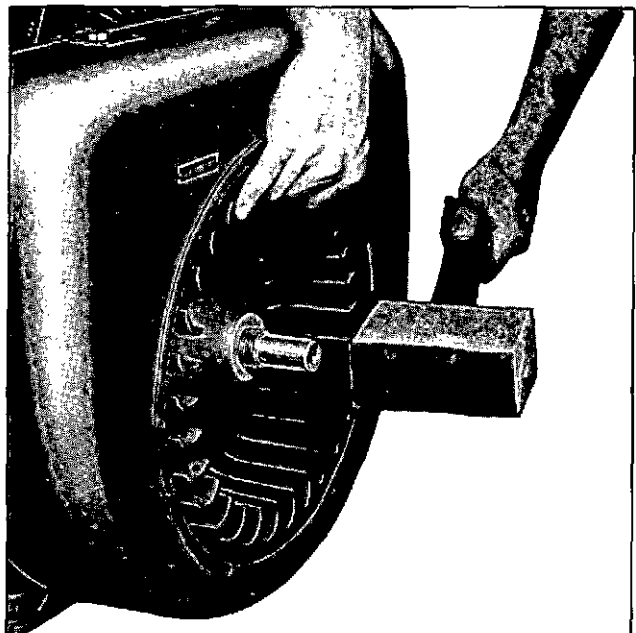

Fig. 18

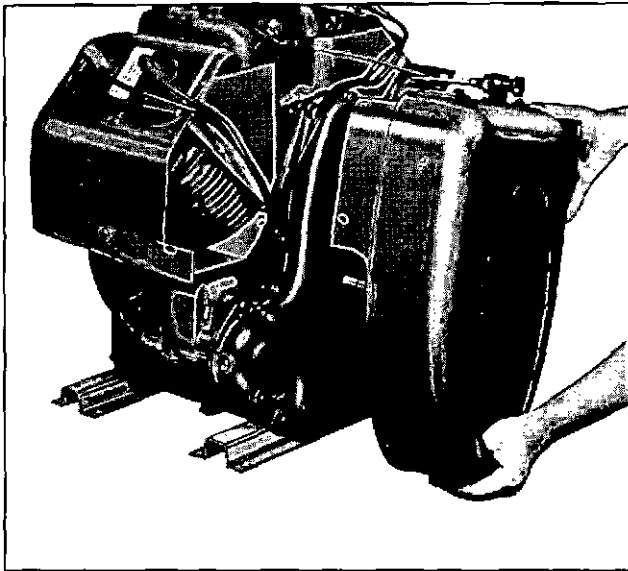

Fig. 19

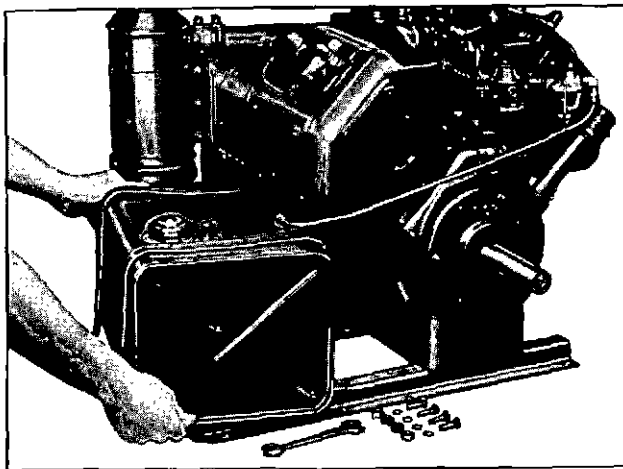

Fig. 20

ing the flywheel shroud to the lower cylinder shrouds and cylinder heat deflectors, then remove the screws holding the flywheel shroud to gear cover.

On power units, remove the front end panel together with flywheel shroud. Remove the rear end panel complete with fuel tank. Balance of shrouding can now be readily removed.

In Reassembly; use the *thin head* capscrews, for mounting the flywheel shroud, in the two holes close to the horizontal centerline. This is for *stator* clearance on engines with flywheel alternator.

FUEL TANK

If a side mount fuel tank is used, disconnect fuel line and remove tank assembly as illustrated in Fig. 20.

CARBURETOR AND MANIFOLD

The carburetor and manifold can be removed as a complete unit. *In reassembly;* tighten the manifold nuts to 18 ft. lbs. torque. Tightening beyond specifications may cause the flanges to break.

CYLINDER HEAD

The cylinder head must be removed if it is necessary to regrind valves, or to work on the piston, rings or connecting rods. All of the cylinder head screws are plainly in view and can be easily removed. Screws of different lengths are used but these can be properly reassembled according to the various lengths of cylinder head bosses.

In reassembly; remove all carbon and lead deposits from combustion chamber. It is recommended that new cylinder head gaskets be used as the old gaskets will be compressed and hard and may not seal properly. Use a mixture of graphite and oil on the cylinder head screws to prevent them from rusting tight against the cylinder block. Tighten cylinder head screws to 24 ft. lbs. torque in the sequence shown in Fig. 21. After complete assembly and engine is run in, re-torque head screws.

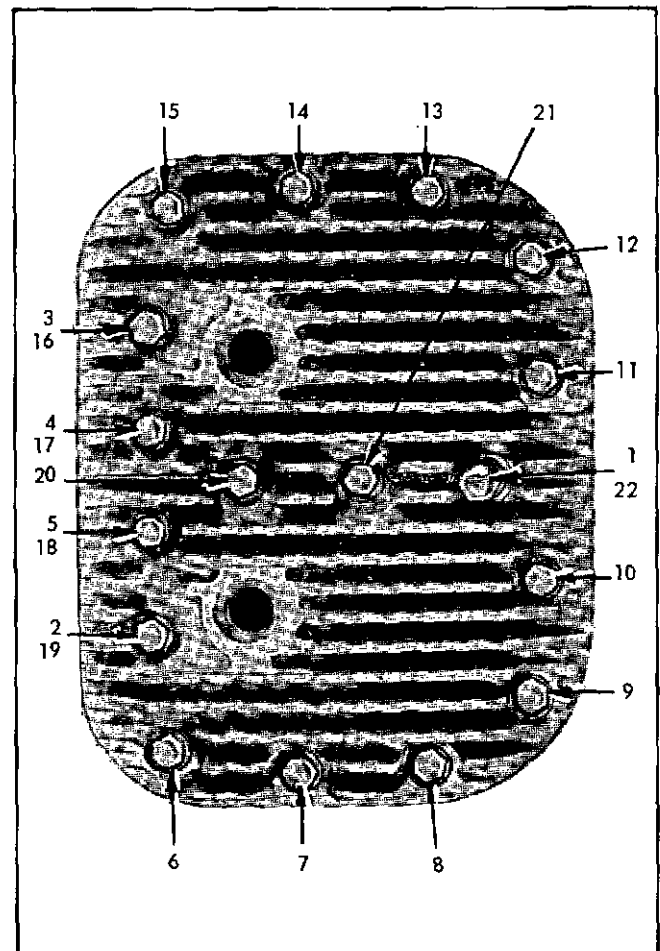

Fig. 21

GEAR COVER

Disconnect the governor linkage and remove governor housing and gear-flyweight assembly from shaft in gear cover. Take out the ten gear cover capscrews and drive out the two dowel pins as shown in Fig. 23. The cover can then be taken off - exposing the gear train as illustrated in Fig. 24.

In reassembly; inspect crankshaft oil seal and replace if necessary. Be sure that oil sling is in place on crankshaft, then mount gear cover using a new flange gasket. Tap the two dowel pins in place and mount capscrews. Tighten screws 14 to 18 ft. lbs. torque.

CAMSHAFT GEAR

If it is necessary that the camshaft gear be removed, first pry oil sling off crankshaft, and remove thrust plunger and spring from end of camshaft. Take out the three capscrews and lockwashers, and remove gear from camshaft using a screw driver or similar wedge tool.

The *camshaft gear* has offset mounting holes to provide accurate assembly for valve timing. The gear can only be put on the correct way for matching up the timing mark with that of the crankshaft gear. See Fig. 24.

IDLER GEAR AND SHAFT

A tapped hole in the side of the crankcase contains a setscrew for locking idler shaft in place. See Fig. 25. Remove screw with a 5/32" Allen wrench. Disassemble shaft and gear from case by means of the 3/8"-16 tapped puller hole in end of idler shaft.

In reassembly; be sure oil groove in shaft is facing up. Drive shaft into crankcase with soft metal hammer and maintain a .003 to .004 inch clearance between idler gear and shoulder of shaft. Lock shaft in place with the Allen set screw.

OIL PAN

The engine can now be inverted so that the supports and oil pan can be removed, see Fig. 26.

In reassembly; tighten oil pan mounting screws, 6 to 9 foot pounds torque.

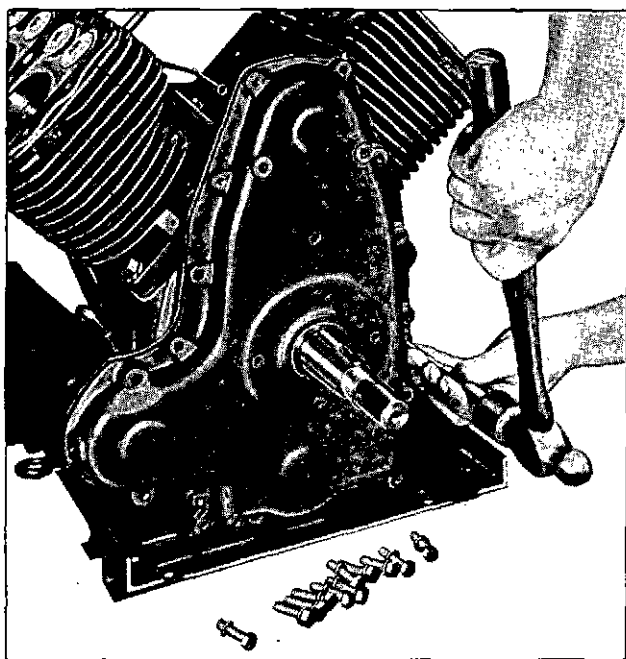

Fig. 23

OIL PUMP (Fig. 27)

Remove locknut and driver gear from shaft. If gear is too tight to remove by hand, use a puller, *hammering* on end of shaft to loosen gear will *damage pump*.

Take out slotted pipe plug from bottom of crankcase. By means of a 5/32 inch Allen wrench, remove lock-screw from pipe plug hole. Withdraw oil pump from inside crankcase. If pump fits too tight to remove by hand, tap front of pump housing (not shaft), with hammer and brass rod.

PISTONS and CONNECTING RODS (Figs. 28, 29, 32)

By means of a 1/2" socket wrench, loosen and remove the hex locknuts from connecting rod bolts. Then, by tapping the ends of the bolts lightly, the connecting rod cap will break free from the bolts.

Scrape off all carbon deposits that might interfere with removal of pistons from upper end of cylinder. Turn

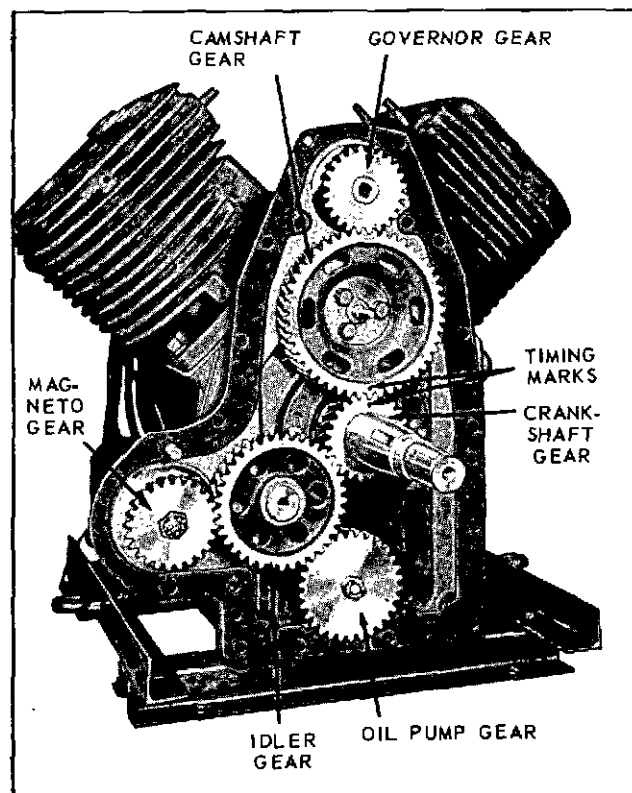

Fig. 24

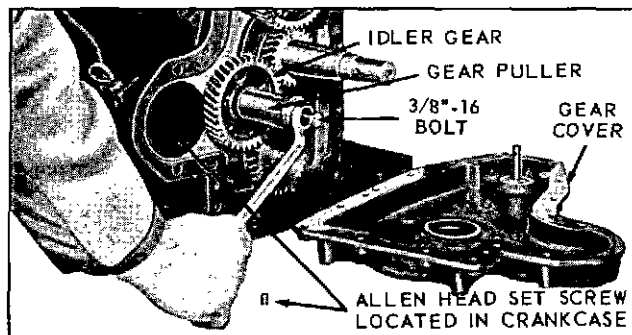

Fig. 25

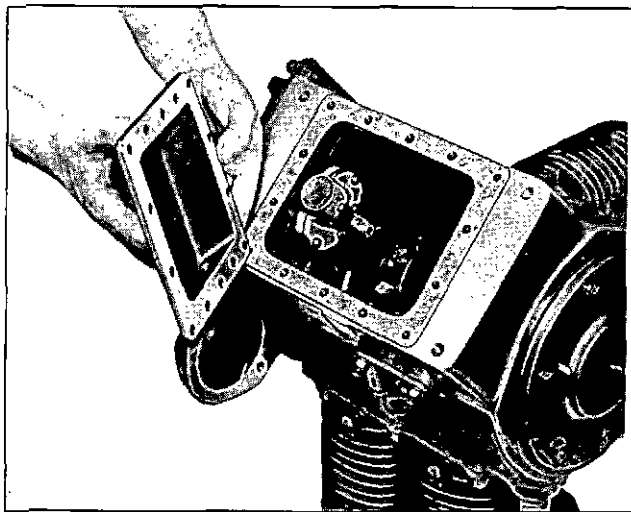

Fig. 26

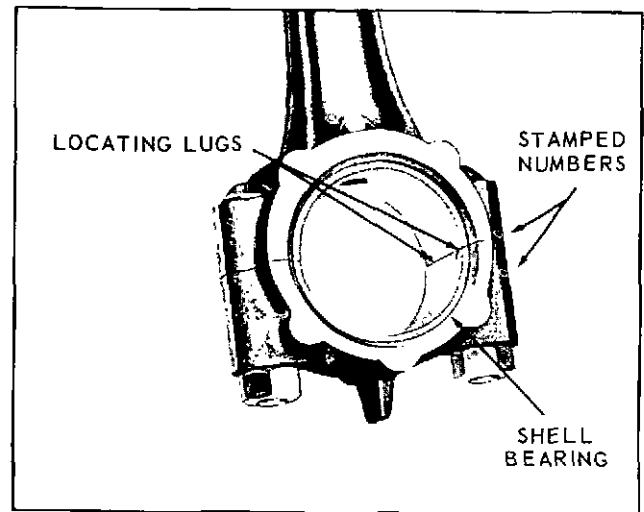

Fig. 28

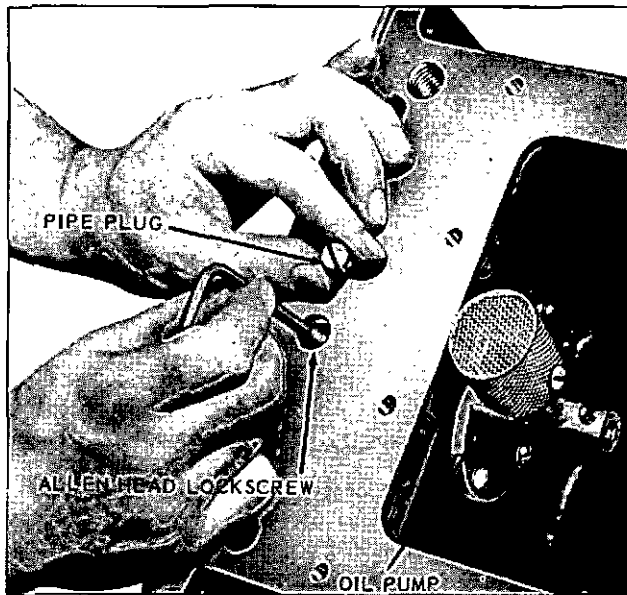

Fig. 27

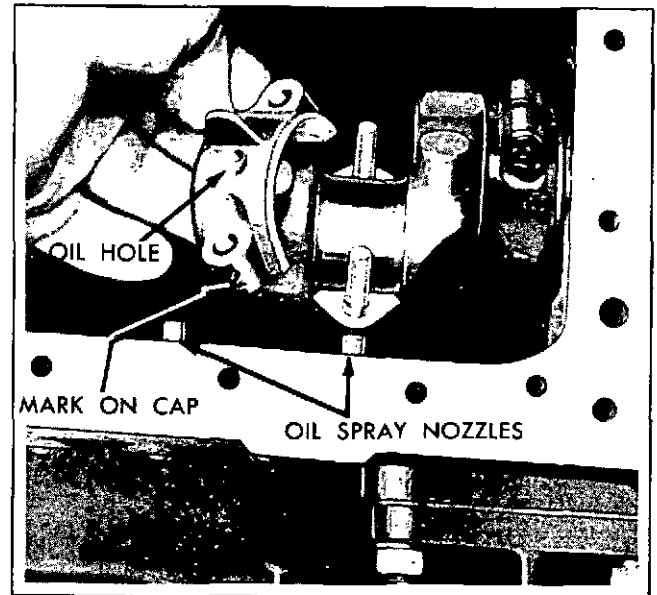

Fig. 29

crankshaft until piston is at top, then push connecting rod and piston assembly upward and out thru top of cylinder. Be careful not to mar the crank pin by allowing the rod bolts to strike or scrape across it. Place caps on rods immediately so that they will not be mismatched in reassembly. Be sure that shims (used in babbitt bearing rods), are in place before cap is put on.

NOTE: These models of engines were originally furnished with *babbitt cast* connecting rod bearings. *Shell bearing* rods are now being used for current production engines, and are interchangeable with babbitt bearing rods for service replacement. Care should be taken *in reassembly* to mount bearings properly. The cap should be assembled to the rod so that the *locating lug* of both bearing halves are on the same side as illustrated in Fig. 28. Refer to chart, Fig. 32, for clearance between bearing and crank pin.

The piston skirt is *cam-ground* to an elliptical contour. Clearance between the piston and cylinder must be measured at the center of the thrust face at the bottom of the piston skirt. Refer to Chart, Fig. 32, for proper clearance. The thrust faces on the piston skirt

are 90° from the axis of the piston pin hole, with the wide section of the piston skirt toward the maximum thrust side, or opposite the crankshaft rotation. See *Engine Sectional, Fig. 2.*

In reassembly; be sure piston and connecting rod assemblies are put back into the same bore from which they were removed. Use a suitable ring compressor and stagger the piston ring gaps 90° apart around the piston. Oil the pistons, rings, wrist pins, rod bearings and cylinder walls before assembly.

CAUTION: Identical numbers are stamped on the side of the rod with its corresponding cap. These numbers must be on the same side of the connecting rod when mounted in engine. Be sure that *oil hole* in connecting rod cap is facing toward the oil spray nozzle, as illustrated in Fig. 29. *Install new nuts* on connecting rod bolts and *torque 22 to 28 foot pounds.*

PISTON RINGS (Fig's. 30, 31, 32)

If a ring expander tool is not available, install rings by placing the open end of ring on piston first, as shown in Fig. 30. Spread ring only far enough to slip

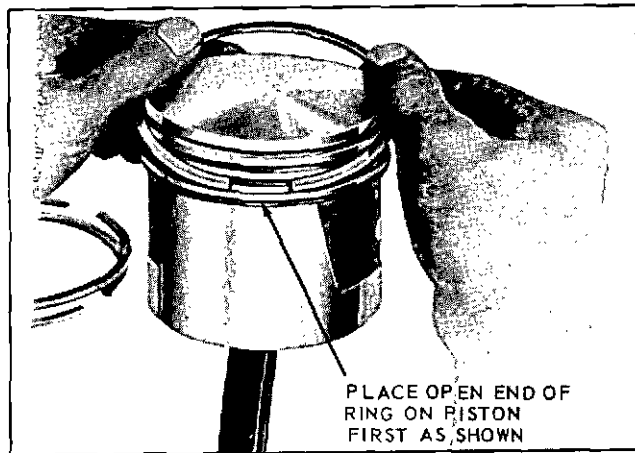

Fig. 30

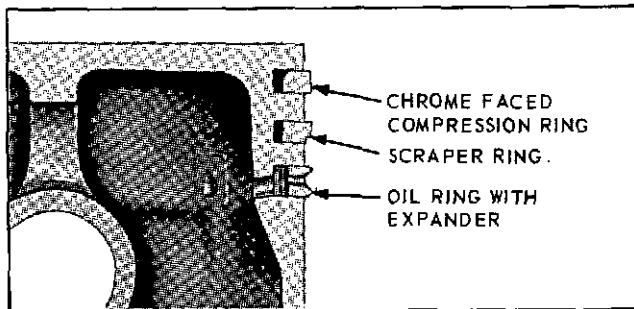

Fig. 31

over piston and into correct groove, being careful not to distort ring. Install bottom ring first and work toward the head of the piston, installing top ring last. The word **'TOP'** on compression and scraper rings indicates direction of ring placement on piston.

Beginning with serial #5538322, *three ring* pistons (chrome faced *compression ring*, *scraper ring*, *oil ring* and *expander*), with improved oil control characteristics, replaces four ring pistons furnished with two *compression rings*.

CAUTION: When replacing four ring pistons with three ring pistons, a complete set of *four pistons* must be used. **Do not** mix three and four ring pistons in the same engine.

The outer diameter of the compression ring is *chrome plated*. Mount scraper ring with *scraper edge* down, otherwise oil pumping and excessive oil consumption will result. Refer to Fig. 31 for the correct placement of piston rings.

CYLINDER BLOCKS

Clean all dirt and foreign deposits from between the cylinder fins and manifold ports.

The cylinder blocks do not have to be removed unless the cylinder bore is scored, out-of-round, or worn over-size more than 0.005 inch. In this event, the block will have to be removed, rebored and fitted with over-size pistons and rings. This work should be done by an authorized Wisconsin Service Center.

In Reassembly; tighten the cylinder block mounting nuts, 40 to 50 foot pounds torque.

PISTON TO CYLINDER AT PISTON SKIRT THRUST FACE		.003 to .004"
PISTON RING GAP		.010 to .020"
PISTON RING SIDE CLEARANCE IN GROOVES	TOP RING	.002 to .004"
	SCRAPER RING	.002 to .004"
	OIL RING	.001 to .003"
PISTON PIN TO CONNECTING ROD BUSHING		.0004 to .0012"
PISTON PIN TO PISTON		.0000 to .0008" tight
CONNECTING ROD TO CRANK PIN - SIDE CLEARANCE		.009 to .016"
CONNECTING ROD SHELL BEARING TO CRANK PIN DIA. (VERTICAL)		.0012 to .0033"
CONNECTING ROD BABBITT BEARING TO CRANK PIN		.0007 to .0020"

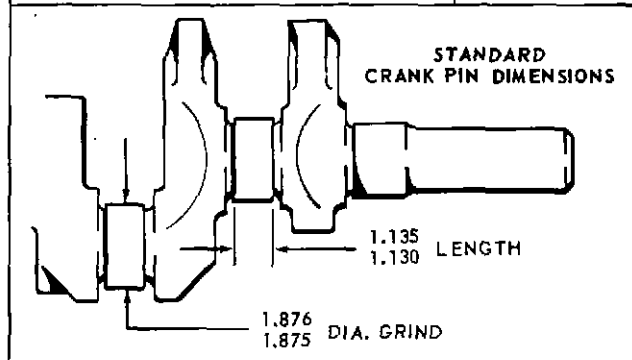

Fig. 32, PISTON, RING AND ROD CLEARANCES CHART

VALVES and SEAT INSERTS (Fig. 33)

Remove valve tappet inspection plate and compress valve springs with a standard automotive type valve lifter as illustrated. Insert a rag in the opening at the bottom of valve chamber so the retaining locks do not fall into engine crankcase. Remove retaining locks, seats, springs, valves and clean these, as well as the ports and guides, of all carbon and gum deposits. Tag each valve so that in reassembly they will be mounted in the same guide they were removed from. Replace valves that are burned or pitted.

The inlet and exhaust valve *seat inserts* can be removed, when replacement becomes necessary, by means of Wisconsin Motor **DF-66-A** insert puller.

Before grinding valves, inspect valve guides for possible replacement. Refer to *Valve Guide* paragraph. The valve face is ground at 45° to the vertical center line of the valve stem and the valve seat insert should also be ground at a 45° angle. **After grinding,** lap valves in place until a uniform ring will show entirely around the face of the valve. Clean valves and wash block thoroughly with a hot solution of soap and water. Wipe cylinder walls with clean lint free rags and light engine oil, especially if cylinders were rebored and honed.

Valve guides in the cylinder block are easily replaceable by use of Wisconsin **DF-72 driver tool**. **In reassembly;** mount guides with inside chamfer down. The valve stem has a clearance of .003 to .005" in the guide. When the clearance becomes

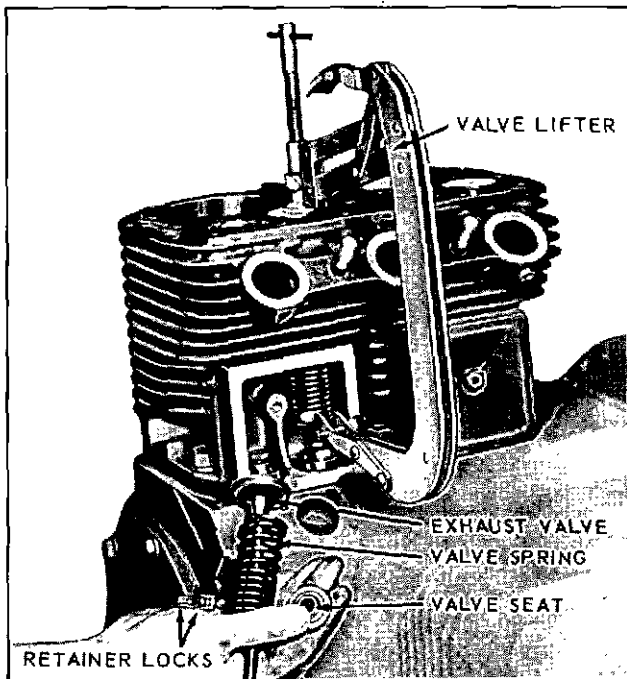

Fig. 33

.007", the guides should be driven out and replaced with new guides.

These engines that have *Stellite* exhaust valves and inserts are designated as Model *VH4D* and are equipped with *positive* type *exhaust valve rotators*. The action of the rotocap, which rotates the valve slightly each time the valve opens, helps prevent sticky valve and will impart a wiping action between the valve face and valve seat, thereby preventing the build-up of foreign deposits. Valve rotation will also avoid prolonged exposure of any one sector of the valve face to a local hot spot on the seat which will result in lower and more uniform valve face-seat temperatures.

CRANKSHAFT

To remove the crankshaft, first remove the six cap-screws in the main bearing plate at the take-off end of the engine. This plate can then be pried off, and crankshaft removed from that end of crankcase. See *Fig. 34*. Be sure to keep shims and gaskets in place as these are necessary to give the proper end play to

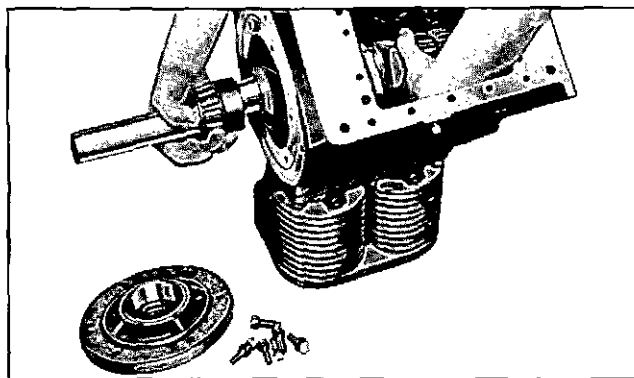

Fig. 34

the tapered roller main bearings on the crankshaft. This *end play* should be .002 to .004 inch when engine is cold. There is practically no wear in these bearings so that no readjustment is necessary after proper assembly.

When reassembling crankshaft, the timing marks on the crankshaft gear and the camshaft gear must be matched as shown in *Fig. 24*, otherwise engine will not operate properly, or if timing is off considerably, engine will not run at all.

The mounting holes for the main bearing plate are off-set in such a manner that it can only be mounted in the correct position. Tighten main bearing plate capscrews, 25 to 30 foot pounds torque.

CAMSHAFT

The camshaft must be withdrawn from the flywheel end of the engine as shown in *Fig. 35*. When reassembling, be sure the spring and plunger are in place in the end of the camshaft, as they hold the camshaft in position endwise. These parts are shown in the sectional view of the engine, *Fig. 2*.

VALVE TAPPETS

The valve tappets are taken out after the camshaft is removed. In reassembly, the tappets must of course be inserted in proper position in crankcase, before the camshaft is assembled.

After the cylinder blocks have been assembled to the crankcase, adjust the valve tappets as shown in *Fig. 36*. With the tappets in their lowest positions, engine cold, the clearance should be .008 inch for the *inlet* and .016 inch for the *exhaust*, with or without *Stellite* valves.

GOVERNOR - OPERATION

The centrifugal flyball governor rotates on a stationary pin driven into the upper part of the timing gear

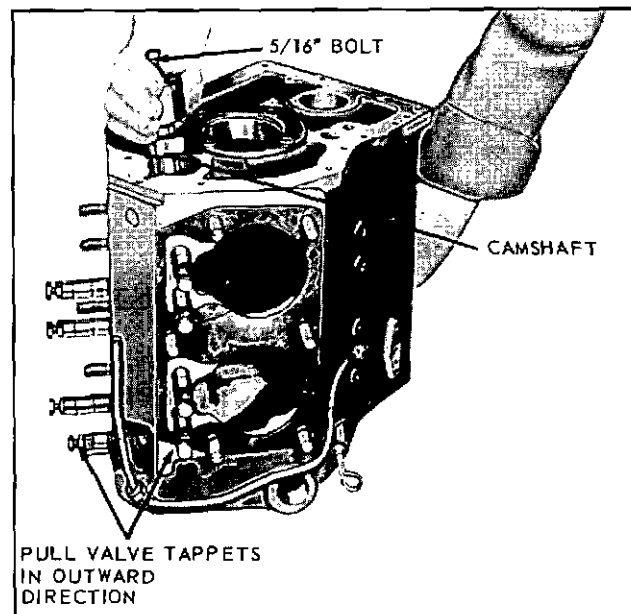

Fig. 35

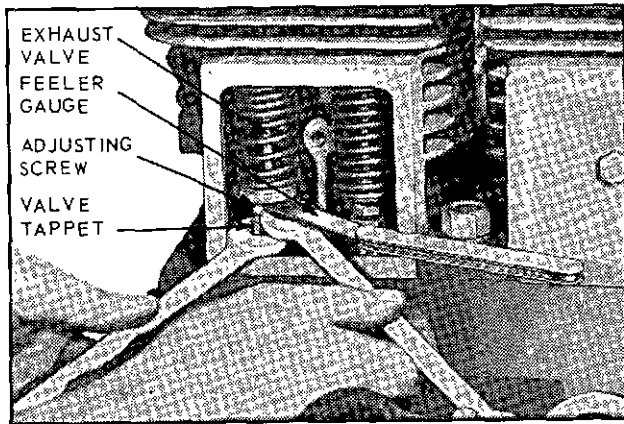

Fig. 36

cover, and the governor is driven off the camshaft gear at crankshaft speed.

Flyweights are hinged to lugs on the drive gear. Hardened pins on the flyweights bear against the flanged sliding sleeve, moving it back and forth as the flyweights move in or out. The motion of the sleeve is transmitted through a ball thrust bearing to the governor lever, which in turn is connected to the carburetor throttle lever. A spring connected to the governor lever tends to hold the governor flyweights to their *inner* position, also to hold the carburetor throttle open. As the engine speed increases, the centrifugal force in the flyweights acts against the spring and closes the throttle to a point where the engine speed will be maintained practically constant under varying load conditions. This speed can be varied to suit conditions by adjusting the governor spring tension to suit.

GOVERNOR ADJUSTMENT

The governor rod connection to the carburetor must be very carefully adjusted for length, otherwise the governor will not function properly and cause the engine to surge badly. With the engine at rest, the governor spring will keep the flyweights *in*, and the control rod must be of such length as to hold the carburetor throttle wide open at that point. The accuracy of this adjustment can be tested by disconnecting the control rod from the governor lever, and then pushing the rod toward the carburetor as far as it will go. This will open the throttle wide. The governor lever should then be moved as far as possible in the same direction, all of this being done with the rod disconnected from the lever. Holding both parts in the above position, the rod should be screwed into the swivel block on the carburetor, until the bent end of the rod will register with the hole in the lever, then, screw the rod in two more turns. Insert the rod into the hole in the governor lever and assemble cotter pin. With the governor lever pushed toward the carburetor as far as it will go, there should be about a 1/16 inch clearance between the throttle lever and the stop pin on the carburetor. The clearance will cause the lever to bounce back from the stop pin, rather than jam against the pin, when a load is suddenly applied to an idling engine. This will eliminate excessive wear on the threads in the carburetor throttle swivel block.

STANDARD Vertical Mounted Carburetor			SPECIAL Horizontal Mtd. Carburetor - Top Mtd. Distributor		GOVERNOR LEVER
LOAD R.P.M.	NO LOAD R.P.M.	HOLE NO.	NO LOAD R.P.M.	HOLE NO.	
1400	1525	4	1600	4	
1500	1650	5	1735	5	
1600	1725	5	1775	5	
1700	1850	6	1905	6	
1800	1950	7	2050	7	
1900	2025	7	2115	7	
2000	2150	8	2230	8	
2100	2225	8	2300	8	
2200	2350	9	2430	9	
2300	2425	9	2480	9	
2400	2550	10	2625	10	
2500	2625	10	2685	10	
2600	2750	11	2795	11	
2700	2850	12	2930	12	
2800	2925	12	3005	12	

Fig. 37

The governor lever is furnished with 12 holes, as shown in Fig. 37, for attaching the governor spring. It is very important that the spring is hooked into the proper hole to suit the speed at which the engine is to be operated. The Governor Lever Chart, Fig. 37, shows the *full load* and *no load* speeds of the engine and the hole corresponding thereto. Note that the *full load* speed is less than the *no load* speed and this must be taken into consideration when readjusting the governor. As an example; if the engine is to be operated at 2000 revolutions per minute under load, the spring should be hooked into the 8th hole in the governor lever, and the spring tension adjusted by means of the adjusting screw, to run 2150 R.P.M. at no load. When load is applied, the engine will run at approximately 2000 R.P.M.

A tachometer or revolution counter should be used against the crankshaft to check speed while adjusting the governor spring tension. Tightening the adjusting screw locknut will give higher speeds, while loosening the locknut will lower the spring tension and reduce the R.P.M.

NOTE: The settings, in the column of Fig. 37 marked *special*, are for engines that have an Ignition Distributor attached to and driven off the governor. These engines have a horizontal mounted carburetor, resulting in governor settings different than standard.

CLUTCH AND REDUCTION GEARS

CLUTCH

The clutch furnished with this model of engine is of the disc type running in oil. Use the same grade of oil in the clutch as is used in the engine crankcase. The oil should be filled through the inspection plate opening, to the height of the oil level plug. Approximately a pint of oil is required. See Fig. 38.

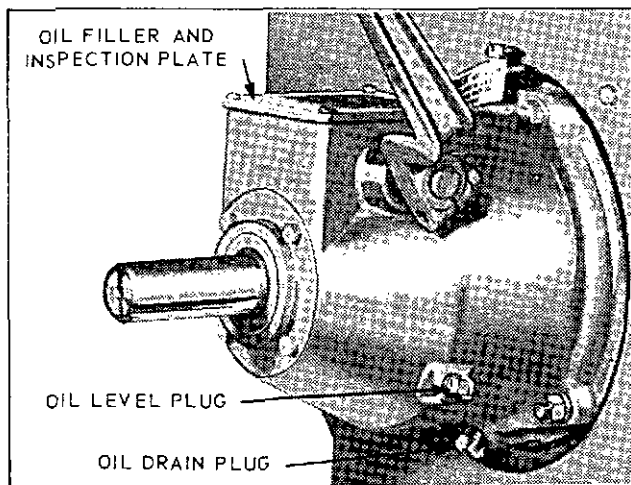

Fig. 38

CLUTCH ADJUSTMENT

If the clutch begins to slip, it should be readjusted, otherwise it will become overheated and damaged. First remove the inspection plate which will expose the notched *adjusting ring*. Release the *clutch*, by pushing the *engaging lever* forward. Turn engine over until the *clutch adjustment lock* is visible thru the inspection opening. Loosen *adjustment lock screw*, one full turn. Keep the engine crankshaft from turning, then, by means of a screw driver as shown in Fig. 39, turn the *adjusting ring*, one notch at a time in a clockwise direction, until a very firm pressure is required to engage the clutch with the lever. Be sure that the clutch cams snap over-center on final adjustment. Securely tighten *adjustment lock screw*. Assemble inspection plate, being sure that the gasket fits properly and is not broken.

CLUTCH REDUCTION UNIT

ADJUSTMENT

The clutch in the clutch reduction unit is the same as used in the clutch take-off assembly. The clutch adjustment is made thru two pipe tap openings; one for the *adjustment lock screw* and the other for turning the *adjusting ring*, as illustrated in Fig. 40. There are four 1/2 inch square head pipe plugs in the housing, to provide a means of adjusting the clutch regardless of what position the unit is mounted in.

Remove the two pipe plugs on the side of the housing (if not accessible, use the two optional taps). Disengage the clutch and turn engine over slowly with a hand crank until the *adjustment lock screw* is visible thru the pipe plug opening nearest to the engine. Loosen *lock screw* one full turn, or enough to relieve the tension of the lock against the notches on the *adjusting ring*. Then, turn engine over slightly to expose the *notches on adjusting ring*. Keep engine crankshaft from turning, while thru the adjacent pipe plug opening, turn the *adjusting ring* with a screw driver, one notch at a time in a clockwise direction (viewing from take-off end), until a very firm pressure is required to engage the clutch with the lever. Tighten *adjustment lock screw* and mount pipe plugs, when adjustment is completed.

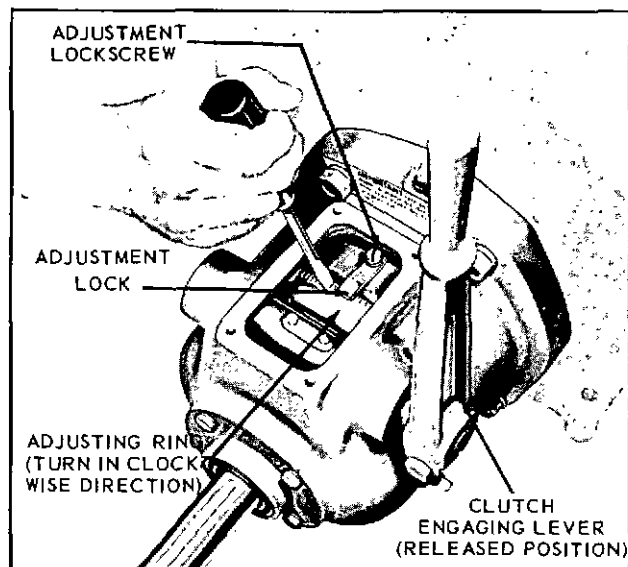

Fig. 39

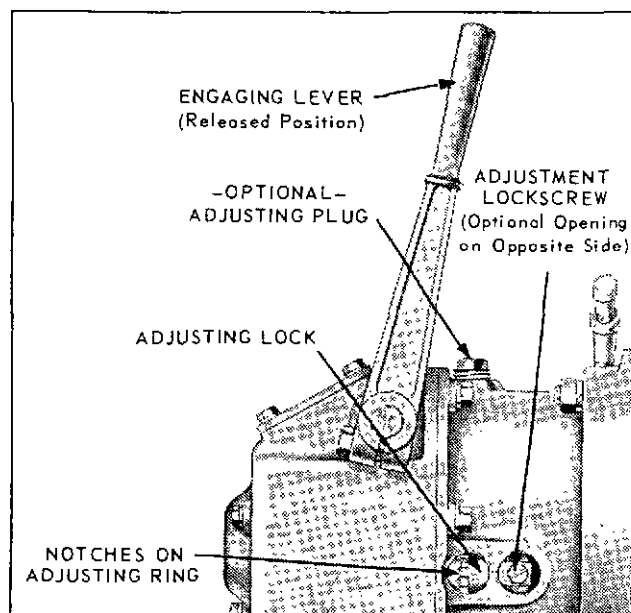

Fig. 40

REDUCTION GEARS

Reduction gears are furnished with several different ratios, some with spur gears, others with chains. All are of the same general design, except that some are furnished with clutches, others without, and for various installations can be mounted with the take-off shaft in either a 3, 6, 9 or 12 o'clock position. Use the same grade of oil in the reduction unit as is used in the engine crankcase.

Several plugs are furnished so that lubrication may be properly taken care of regardless of the position of the installation. There will always be one plug on top to be used for filling oil, a plug below for draining oil, and there will be one plug on the side slightly above the bottom, to be used as an oil level plug. See Fig. 41.

The oil should always be filled when the engine is at rest. When the oil becomes dirty, it should be drained, while the engine is hot, and fresh oil added. The fre-

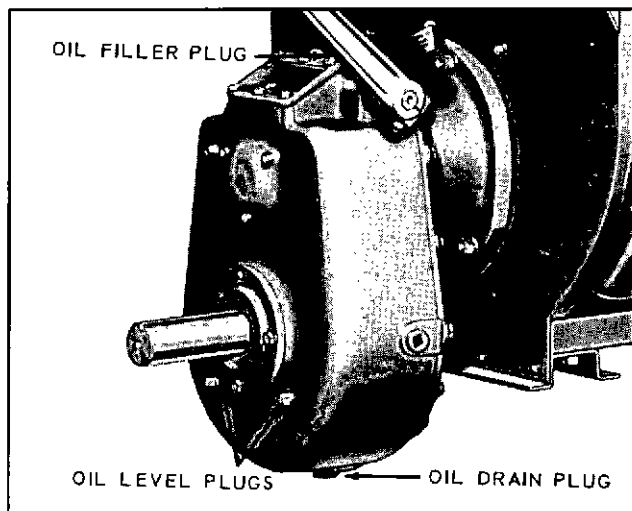

Fig. 41

quency at which these oil changes should be made depends entirely on the kind of service in which these gears are used, but even with light service the change should be made at least once every five hundred hours of operation, adding sufficient oil between changes to keep the oil up to the oil level plug.

STORAGE OF ENGINE FOR WINTER

When the season's work is completed, the following instructions should be carried out very carefully to protect the engine over winter.

The outside of the engine, including the cooling fins on the cylinders and heads, should be thoroughly cleaned of all dirt and other deposits.

The air cleaner, at the carburetor intake, should be thoroughly cleaned of all oil and accumulated dust, and the sediment removed from the oil cup at the bottom of the cleaner.

To protect the cylinders, pistons, rings and valves and keep them from rusting and sticking, a half and half mixture of kerosene and good "gasoline engine" oil (the same kind of oil as used in the crankcase of the engine), should be injected into the *pipe tap* opening on the *intake manifold* while the engine is warm and running at moderate speed. About a quarter of a pint is necessary, or enough so that a heavy bluish smoke will appear at the exhaust. The ignition switch should then be shut off and the engine stopped. This fogging operation will leave a coating of oil on the above mentioned parts, protecting them from the atmosphere.

On engines where the pipe tap opening on the intake manifold is inaccessible, the rust preventative may be injected into the air intake on the carburetor while the engine is running, so the mixture will be drawn into the engine. The air cleaner connection will of course have to be disconnected from the carburetor to do this.

All the oil should be drained from the crankcase while the engine is warm, as the oil will then flow more freely than when cold.

Drain fuel system, including gasoline lines, carburetor, fuel pump and tank of all gasoline, to prevent lead and gum sediment interfering with future operation.

The air cleaner or carburetor intake, as well as the exhaust manifold and breather openings, should be taped or otherwise sealed off, for the duration of the storage period.

All exposed unpainted metal parts should be coated with grease or heavy oil.

Before starting the engine again the next season, the crankcase drain plug should again be removed, so that any condensation, which may have collected during the winter, may be drained before new crankcase oil is added.

A good plan, and one that is recommended, is to remove the crankcase oil base in the spring before starting the engine for the new season, and scrubbing off all sediment which may have collected there.

When replacing the engine base, a new gasket should be used.

Be sure to fill the crankcase with a good quality of crankcase oil to the high level point, before starting the engine. Do not use any oil heavier than SAE No. 30. Also be sure to put oil to the proper level in the air cleaner.

It is also recommended to use new spark plugs at the beginning of the next season, especially if the engine has given considerable service.

Refuel engine and follow the starting instructions as shown on preceding pages of this manual.

It is highly recommended that machines be stored inside a building through the winter. If this is not possible, the engine should be protected from snow and ice by a proper covering.

FUEL PUMP SERVICE INSTRUCTIONS

WISCONSIN FUEL PUMPS, No. LP-38E, LP-38H and LP-38F (Cold Weather: -65°F)
For all 4 cylinder engine models

The fuel pump, like all other parts of the engine, is subject to wear and you will find that any time after 500 hours of use, its efficiency will gradually decrease. This is indicated by the engines faltering at high speeds or when heavy loads are suddenly applied. The pump can easily be restored to its normal efficiency by the installation of a repair kit. Wisconsin LQ-46 (for LP-38E), LQ-47 (for LP-38H) or LQ-46A (LP-38F, cold weather, -65°).

1. Disconnect fuel lines from pump and remove fuel strainer if mounted to pump. Remove fuel pump from adapter housing by taking out the two mounting screws.
2. File a groove across a point at the union of castings (15 and 16). This is a positive location of the fuel INLET and OUTLET positions when reassembling. Remove six head to flange screws (3) and remove fuel head. Take off screw (2), remove cover (7) and discard gasket (4).
3. Turn fuel head (16) over and remove both valve assemblies (5), and gaskets (6). Note position of valves.
4. Clean head thoroughly with kerosene or diesel fuel and a fine brush.
5. Place fuel head (16) with diaphragm surface up. Assemble new valve gaskets (6) and mount valve assemblies (5) in positions shown on illustration. Press valves in evenly without distortion, and stake in place.
6. Mount new cover gasket (4), cover (7) and washer (8). Securely tighten in place with cover screw (2).
7. Set fuel head assembly aside and proceed to rebuild lower diaphragm section.
8. Insert the end of a small screw driver into the coils of rocker arm spring (12) and remove.
9. Hold mounting bracket (15) in the left hand, with the rocker arm toward your body and the thumb nail on the end of link (10). With the heel of right hand on diaphragm (1), compress the diaphragm spring (11), and at the same time pull toward your body. Unhook link (10) from end of diaphragm and remove.
10. Remove rocker arm pin (13). Note that pin is larger on one end. Drive pin out by means of a punch from small end.
11. Clean mounting bracket (15) with kerosene or diesel fuel.
12. Assemble new link (10), bushing (9) and pin (13) to bracket (15) along with rocker arm (14). Stake rocker arm pin (10) in bracket to keep it in place.
13. Place new diaphragm spring (11) into bracket (15). Repeat in reverse order paragraph 9, using a new diaphragm (1). Assemble new rocker arm spring (12).
14. Mount this assembly to adapter on engine using new flange gasket (17).
15. Crank the engine over to a position where the diaphragm (1) is laying flat on the mounting bracket (15). Place the fuel head assembly back in position so the locating grooves of Step 2 are in line, and start the six head screws approximately three turns. Again crank the engine over to where the diaphragm (1) is pulled down into mounting bracket (15) to its lowest position. Securely tighten the six head screws (3).
16. Mount fuel strainer to fuel inlet and connect fuel lines.

NOTE: The LQ-46, LQ-47 or LQ-46-A Repair Kit and the parts included there-in, which are identified by an asterisk (*), are the only parts of the fuel pump available for service.

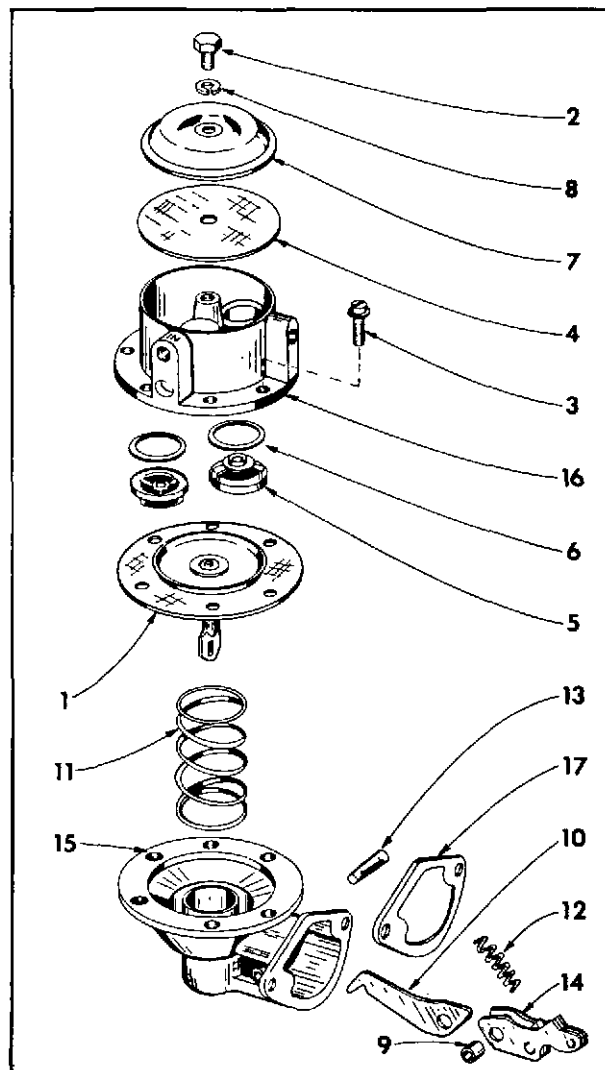

Ref. No.	Description	No. Req.
* 1	DIAPHRAGM	1
2	COVER SCREW	1
3	SCREW, head to bracket mounting	6
* 4	GASKET, cover (pulsator in LQ-47)	1
* 5	VALVE ASSEMBLY	2
* 6	GASKET for valve	2
7	COVER	1
8	WASHER for cover screw	1
* 9	BUSHING for rocker arm pin	1
* 10	LINK for rocker arm	1
* 11	SPRING for diaphragm	1
* 12	SPRING for rocker arm	1
* 13	PIN for rocker arm	1
14	ROCKER ARM	1
15	MOUNTING BRACKET	1
16	FUEL HEAD	1
* 17	GASKET for mounting flange	1

FLYWHEEL ALTERNATOR

WITH SOLID STATE REGULATION

12 Volt - 10, 25 and 30 amp Systems for Wisconsin Engines

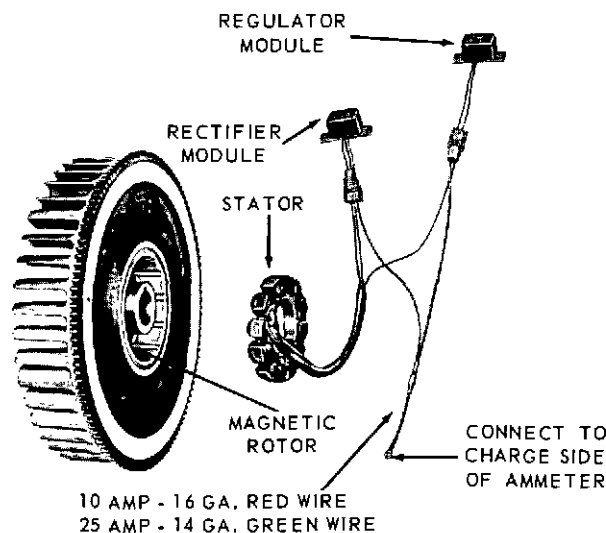

Fig. 42

ELECTRICAL EQUIPMENT

The **12 volt** Battery Ignition Distributor with Coil and Starting Motor are standard equipment. Options include: 10 amp, 25 amp, or 30 amp Flywheel Alternator, 37 amp Belt Driven Alternator, Instrument Panel, High-Temperature Safety Switch and Solenoid Starting. **Battery is not normally furnished with the engine.**

FLYWHEEL ALTERNATOR, Fig. 42

This flywheel alternator is of the permanent magnet type and has **no brushes, commutator, belts or adjustments**. A series of coils (stator) is mounted to the engine gear cover, and the magnetic flux is provided by a permanent magnet in the flywheel which rotates around these stationary coils. Only four components make up this light weight space saving system; a **flywheel** with magnetic rotor, **stator**, **rectifier** module and **regulator** module. The 30 amp flywheel alternator system uses a combination rectifier/regulator module.

IMPORTANT

This is a **Negative Ground** system. Charging components will be damaged if grounded wrong in connecting or jumping batteries.

WARNING Handle battery carefully to prevent acid burns. Avoid sparks near battery - gas given off by battery is explosive.

Since the physical appearance of both 10 amp and 25 amp **Flywheel Alternator** systems are very similar, they can

be distinguished from each other by the ammeter calibrations; **0 to 15** amps for the 10 amp circuit and **0 to 30** amps for the 25 amp circuit, or by the wire from ammeter to stator-regulator connector; **16 gage red wire** for 10 amp, **14 gage green wire** for 25 amp circuit.

PRECAUTIONS to be exercised in the use of Flywheel Alternator:

1. **Do not** reverse battery connections. Negative battery terminal must be grounded. Reverse polarity will damage rectifier.
2. Connect booster batteries - positive to positive and negative to negative.
3. **Do not** ground any wires from stator or modules which terminate at connectors, or from field terminal of belt driven alternator.
4. **Do not** operate engine with battery disconnected, or disconnect the alternator output lead while the alternator is operating, as damping effect of the battery will be lost. The voltage will rise to an extreme value and permanent damage to the regulator may occur.
5. **Do not** remove alternator from installation without first disconnecting the grounded battery cable.
6. Disconnect ground battery lead if a battery charger is used.

WIRING CIRCUIT, Fig. 42, Fig. 43

The fool-proof type connectors used to prevent incorrect wiring from the stator to the rectifier and regulator modules. To disconnect plugs, squeeze outer ends of receptical and pull apart.

The rectifier is insulated from ground, but the stator and regulator module are grounded to the engine through their mounting surface. The regulator module therefore should not be removed and mounted at some remote location. This is a *negative ground circuit*. Connect ground strap from negative post of battery to starting motor flange, or good clean grounding surface on engine.

FLYWHEEL ALTERNATOR SERVICE PROCEDURE:

PRELIMINARY TESTS

1. **Visual Inspection** should be made to eliminate conditions that may be interpreted as a defected alternator. Examine leads for broken or loose connections, and make sure modules are securely mounted. The **regulator module** must be mounted to a metal surface for grounding purposes, (Test 5.0) while the **rectifier module**, although insulated from ground, should be securely mounted for heat dissipation. The mounting surfaces must be clean and free of contaminants, oil, grease, etc.
2. **Check Battery.** Use a Automotive battery in good condition, fully charged and with clean, tight terminal connections.
3. **Check Ammeter.** Be certain the ammeter is functioning correctly. Amperage output is regulated by engine speed. The maximum amperage output for Model VH4D is:

Maximum RPM	10AMP System	25 AMP System
2800	9 amps	20 amps

When assured that the problem is with the alternator, follow the tests outlined in 'Trouble Shooting'.

TROUBLE SHOOTING

FLYWHEEL ALTERNATOR 12 VOLT - 10 AMP and 25 AMP Systems

Trouble Shooting Procedure is a guide showing methods of testing the charging components. The following chart of **Tests 1.0 to 4.1** are with the **engine running**, and substituting known good components in place of suspected faulty components. **Static Tests 5.0 thru 7.2**, following the running tests, are more conclusive but some test require special Wisconsin Test Lights.

Problem: Battery Overcharge	Possible Cause & Remedy
Test 1.0 Engine not running check battery with DC Voltmeter. 1.1 If voltage is greater than 13.5 volts 1.2 With engine running at full RPM, check battery voltage with DC Voltmeter. 1.3 If the charge increases beyond 13.5 volts. 1.4 If the charge remains under 13.5 volts.	1.1 Place 12 volt light bulb or carbon pile across battery to reduce voltage to below 13.5 volts. 1.3 Faulty regulator. Replace, - static check regulator per Test No. 5.1. 1.4 Alternator functioning properly. Check battery condition.

Fig. 43, WIRING DIAGRAM
ELECTRICAL SYSTEM
WITH
10 AMP or 25 AMP
FLYWHEEL ALTERNATOR

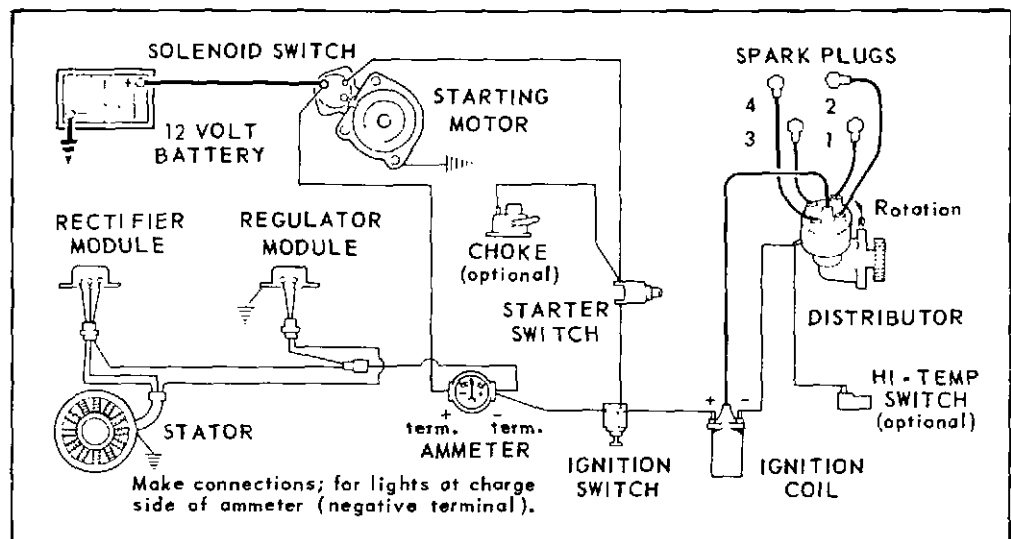

FLYWHEEL ALTERNATOR COMPONENTS

STATIC TESTS

The following test equipment is required:

- DF83 Analyzer - Wisconsin Part, Fig. 44
- DF81 Flashlite Tester - Wisconsin Part, Fig 44
- VOLT-OHM-MILLIAMMETER Simpson 260 or equal.

The DF83 Analyzer was developed for testing the solid state ignition and flywheel alternator components as furnished on *Wisconsin* engines. It is very efficiently and economically powered by four transistor radio type 9 volt batteries. The DF81 Flashlite Tester is used primarily for checking continuity.

Problem: Low/No Charge	Possible Cause & Remedy
Test 2.0 Proceed with Test 1.0 and 1.1. It is necessary to slightly discharge battery to make system work.	
2.1 With engine running at full RPM, check battery voltage with DC Voltmeter.	
2.2 If the charge rate increases -	2.2 Alternator functioning properly. Battery was fully charged.
2.3 If system does not charge	2.3 Operate engine with regulator disconnected (continue with Test 2.4).
2.4 If charge rate increased with regulator disconnected.	2.4 Regulator was at fault. Replace regulator module, - static check regulator per Test No. 5.1.
2.5 If the charge rate does not increase with regulator disconnected.	2.5 Regulator not at fault. Check Rectifier per Test 3.0, 3.1 or static check per Test 6.0.

Problem: Low/No Charge	Possible Cause & Remedy
Test 3.0 Test conditions and procedure the same as 1.0 and 1.1 it is necessary to slightly discharge battery to make system work.	
3.1 Plug new Rectifier in system. Run engine at full RPM.	
3.2 If the charge rate increases with new rectifier in system.	3.2 Rectifier module was at fault. Permanently install new rectifier module.
3.3 If the charge rate does not increase with new Rectifier -	3.3 Rectifier not at fault. Check Stator per Test 4.0.

Problem: Low/No Charge	Possible Cause & Remedy
Test 4.0 With engine stopped, unplug all connectors between modules and stator. Start engine and run at 2400 RPM. With AC voltmeter check voltage between each of the black stator leads and ground.	
4.1 If one of the two voltages is zero or they are over 10% apart. -	4.1 The stator is defective and should be replaced. Static check stator per Tests 7.0, 7.1, 7.2.

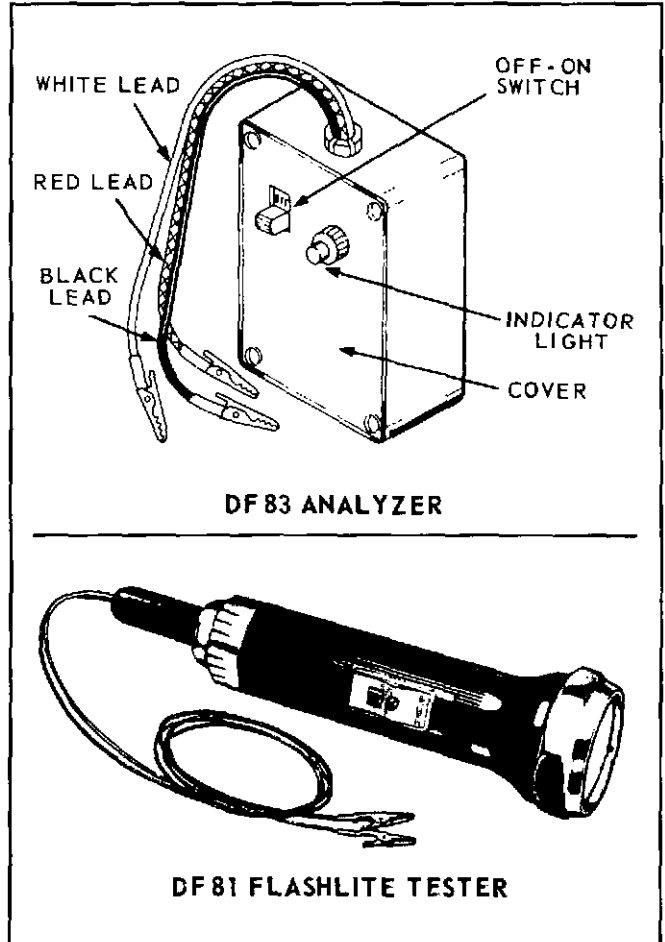

Fig. 44

REGULATOR TESTS

Test 5.0 REGULATOR GROUND

The YJ60 Regulator module must be mounted to a metal surface for grounding purposes. Check for continuity with a VOM (R x 1 scale) or test light.

TESTER RED LEAD	TESTER BLACK LEAD	RESULT
To Regulator Body	To Ground	DF 83 - Light On DF 81 - Light On VOM - Continuity

Test 5.1 REGULATOR STATIC CHECK

This test is an alternative or in addition to running tests 2.3 and 2.4 (omitting regulator). The DF 83 Analyzer is used.

YJ60 REGULATOR

NOTE: Module is defective if light indication is not as shown.

TEST NO.	ANALYZER RED LEAD TO:	ANALYZER BLACK LEAD TO:	ANALYZER WHITE LEAD TO:	LIGHT INDICATION
1	Module Base Plate	Module Red Lead	-	OFF
2	Module Red Lead	Module Base Plate	-	OFF
3	Module Red Lead	Module Base Plate	Module Black Lead Then Remove	On And Remain On

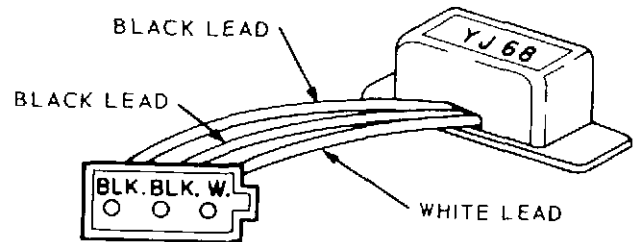
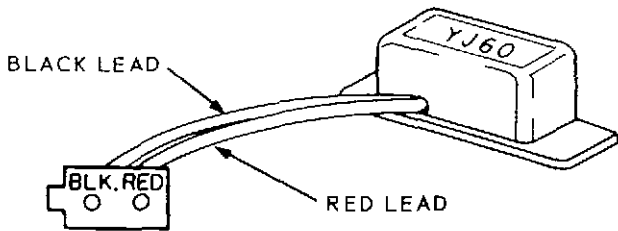

YJ68 RECTIFIER (using DF 81 Flashlite)

TEST NO.	TESTER RED LEAD TO:	TESTER BLACK LEAD TO:	LIGHT INDICATION
1	Module White Lead	Either Module Black Lead	ON
2	Module White Lead	Other Module Black Lead	ON
3	Either Module Black Lead	Module White Lead	OFF
4	Other Module Black Lead	Module White Lead	OFF

YJ68 RECTIFIER (using VOM equipment)

Note: Continuity shall be in one direction only. If readings are not as indicated, replace module.

TEST NO.	VOM RED LEAD TO:	VOM BLACK LEAD TO:	METER INDICATION
1	Module White Lead	Either Module Black Lead	No Continuity
2	Module White Lead	Other Module Black Lead	No Continuity
3	Either Module Black Lead	Module White Lead	Continuity
4	Other Module Black Lead	Module White Lead	Continuity

RECTIFIER TESTS

Test 6.0 RECTIFIER STATIC CHECK

The diodes in the Rectifier module can be checked with any continuity device such as the DF 83 analyzer, DF 81 Flashlite or VOM. Since various testing devices will differ in their operation, it should be noted in the following three Rectifier test charts that the results in tests 1 and 2 should always be opposite to the results of tests 3 and 4.

YJ68 RECTIFIER (using DF 83 Analyzer)

Module is defective if light indication is not as shown.

TEST NO.	ANALYZER RED LEAD TO:	ANALYZER BLACK LEAD TO:	ANALYZER WHITE LEAD TO:	LIGHT INDICATION
1	Module White Lead	Either Module Black Lead	-	OFF
2	Module White Lead	Other Module Black Lead	-	OFF
3	Either Module Black Lead	Module White Lead	-	ON
4	Other Module Black Lead	Module White Lead	-	ON

STATOR TESTS

YB81, 10 amp STATOR

YB82, 25 amp STATOR

The continuity tests for stators is not a 100% method of checking. However, if the stator fails the continuity tests, it is definitely defective. If it passes the tests but all other components have also checked out O.K., the stator may be the defective part of the system and should be replaced. Test can be made with Stator on engine.

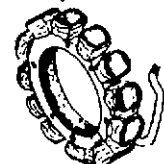

Test 7.0 STATOR GROUND

Like the Regulator, the YB81 and YB82 Stators must be grounded. Stator ground can be checked with any type continuity device.

TEST NO.	TESTER RED LEAD	TESTER BLACK LEAD	RESULT
1	To Stator Black Lead	To Ground	DF 83 - Light On DF 81 - Light On VOM - Continuity
2	To Other Black Lead	To Ground	

Test 7.1 STATOR CONTINUITY

This test should be performed after 7.0 stator ground test. Use continuity equipment such as DF 81 Flashlite or VOM. *Results other than specified indicate a defective stator.*

TEST NO.	TESTER RED LEAD	TESTER BLACK LEAD	RESULT
1	To Ground	To Stator Red Lead	DF 81 - Light On VOM - Continuity
2	To Ground	To Stator Black Lead	
3	To Ground	To Other Black Lead	

Test 7.2 CONTINUITY with DF 83 Analyzer

TEST NO.	ANALYZER RED LEAD TO:	ANALYZER BLACK LEAD TO:	ANALYZER WHITE LEAD TO:	LIGHT INDICATION
1	Stator Black Lead	Ground	-	On
2	Stator Other Black Lead	Ground	-	On
3	Ground	Stator Red Lead	-	On
4	Ground	Stator Black Lead	-	On
5	Ground	Stator Other Black Lead	-	On

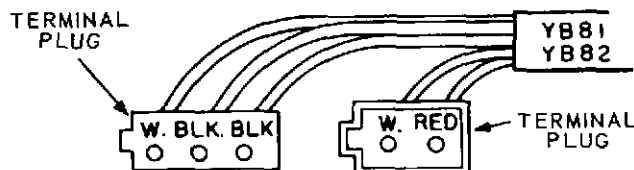

If light indication is other than shown, stator is defective. If stator checks out good, perform voltage test 7.3.

Test 7.3 STATOR RUNNING VOLTAGE

With the engine stopped, unplug all connectors between modules and stator. Start the engine and run at operating speed. Perform the following tests with an AC voltmeter:

TEST NO.	METER RED LEAD	METER BLACK LEAD	STATOR DEFECTIVE IF:
1	To Stator Black Lead	To Ground	Either Reading is 0 or Readings Vary more than 10%
2	To Other Stator Black Lead	To Ground	

BELT DRIVEN ALTERNATOR

The **12 volt - 37 Amp** Automotive type Alternator is optionally available in place of the Flywheel Alternator. No maintenance or adjustments are required other than periodically checking for loose, broken or dirty wire-terminal connections, and for proper drive belt tension. Bearings are pre-lubricated, no additional lubrication is necessary. The Regulator is an all electronic transistorized device, therefore no mechanical contacts or relay adjustments are necessary for voltage regulation.

The alternator is wired into the engine electrical system per Fig. 45.

IMPORTANT

This is a **Negative Ground** system. Charging components will be damaged if grounded wrong in connecting or jumping batteries.

WARNING Handle battery carefully to prevent acid burns. Avoid sparks near battery - gas given off by battery is explosive.

PRECAUTIONS to be exercised in the use of belt driven alternator:

1. Observe proper polarity when installing battery; negative battery terminal must be grounded. Reverse polarity will destroy the rectifier diodes in alternator.
2. As a precautionary measure, disconnect ground battery terminal when charging battery in vehicle. Connecting charger in reverse will destroy the rectifier diodes in the alternator.
3. **Do Not**, under any circumstances, short the field terminal of the alternator to ground, as permanent damage to the regulator may occur.
4. **Do Not**, remove the alternator from the vehicle without first disconnecting the grounded battery cable.
5. **Do Not**, operate engine with battery disconnected, or disconnect the alternator output lead while the alternator is operating, as damping effect of the battery will be lost. The voltage will rise to an extreme value and permanent damage to the regulator may occur.
6. **Do Not**, disconnect the voltage regulator while the alternator is operating, because the large voltage transient that occurs when disconnection takes place may damage the regulator.
7. **Caution:** Output wires from Alternator to Ammeter, and from Ammeter to battery terminal on starting solenoid must be of sufficient size for charging 37 amps. Use No. 10 gage stranded wire, or larger.

30 AMP FLYWHEEL ALTERNATOR

An improved 30 amp flywheel alternator system is now available as an option on VH4D engines. This improved 30 amp system is capable of higher output at lower engine speeds over the 25 amp flywheel alternator system.

This new 30 amp system can be easily recognized by the single regulator-rectifier module. The combination regulator-rectifier (YJ70) is mounted to the cylinder shroud on the VH4D. The YJ70 must be securely mounted

Fig. 45, WIRING DIAGRAM
ELECTRICAL SYSTEM
WITH
BELT DRIVEN ALTERNATOR
AND
SOLENOID STARTING

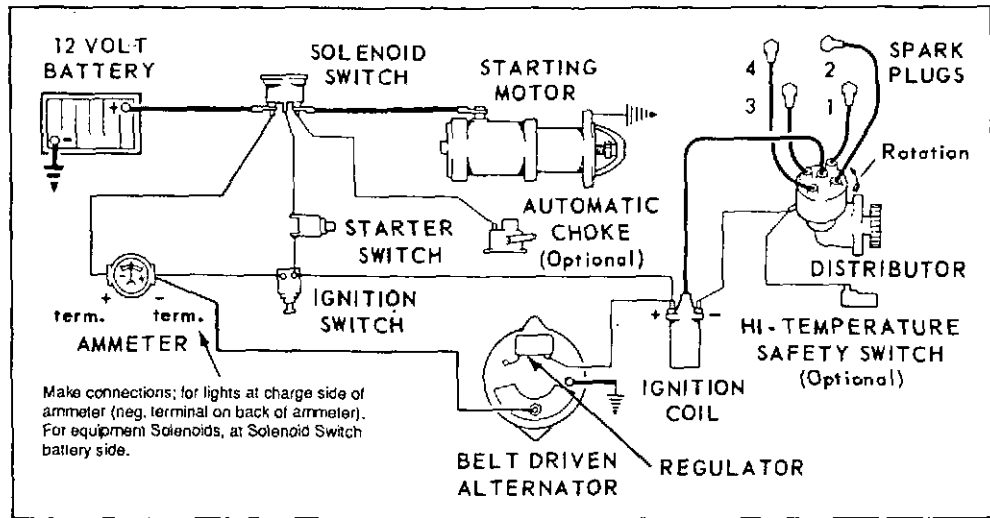

In addition to a new style regulator-rectifier, a new stator (YB84) is used for this 30 amp system. Also, the magnet ring in the flywheel is different than the 25 amp system. In order to change a VH4D from the 25 amp system to this improved 30 amp system, the regulator-rectifier, stator, flywheel, wiring and cylinder shroud must be changed.

30 AMP FLYWHEEL ALTERNATOR TESTING

When testing a charging system which uses the YJ-70 rectifier-regulator module, the following items should be checked:

1. That the charging system is properly wired.
2. That all connections are clean and tight.
3. That the battery is in good condition.

The testing should begin by testing the A.C. voltage output of the stator where the 2 leads attach to the YJ-70. Disconnect the stator leads from the YJ-70 and hook them up to a volt-ohm meter. Use the A.C. voltage scale and the reading should be between 20 and 50 volts A.C. depending upon the engine rpm. (The faster the engine speed, the higher the A.C. voltage should be.) This test checks the stator and magnet ring. If the charging system passes all the previously mentioned checks, then the YJ-70 module can be checked as shown below. Use a good quality ohm meter. All readings are done on the RX100 scale. Do not attempt to use the DF83 analyzer or any other type continuity tester.

YJ-70 RECTIFIER/REGULATOR TESTS

Ohmmeter Leads	Module Terminals	Components Under Test and Indication
1. Neg. (-) → Pos. (+) →	B+ Case	Diode Assembly Insulator, Power SCR's. Meter should indicate no continuity. (Infinity)
2. Neg. (-) → Pos. (+) →	B+ Each AC Terminal	Power Diode Forward Bias Test. Meter should indicate continuity but should not indicate a complete short-circuit. (Some Resistance)
3. Pos. (+) → Neg. (-) →	B+ Case	Regulator Control Circuitry. Meter should indicate no less than 7500 ohms and may read as high as approximately 30,000 ohms.
4. Pos. (+) → Neg. (-) →	Case Each AC Terminal	Power SCR's. Meter should indicate no Continuity. (Infinity)
5. Pos. (+) → Neg. (-) →	B+ Each AC Terminal	Power diode reverse bias test. No continuity. A very high resistance (50,000 - 1,000,000 ohms) may be observed if measured on the high resistance scale of an Ohmmeter.

SERVICE INSTRUCTIONS

DESCRIPTION

The Zenith 87-Series is a horizontal carburetor with a concentric fuel bowl. It is a "balanced" carburetor, because all air for fuel chamber and metering well ventilation and idling must come through the air cleaner. Air cleaner restrictions have a minimum influence on the fuel-air ratio when a carburetor is thus "balanced".

The main jet and discharge jet are centrally located. The metering well which completely surrounds the discharge jet is in the center of the fuel bowl assembly. This construction permits extremely high angle operation in any direction.

The venturi, which is part of the throttle body casting, measures the volume of air that passes through the carburetor. In selecting the venturi size, the smallest size that will permit full power development should be used.

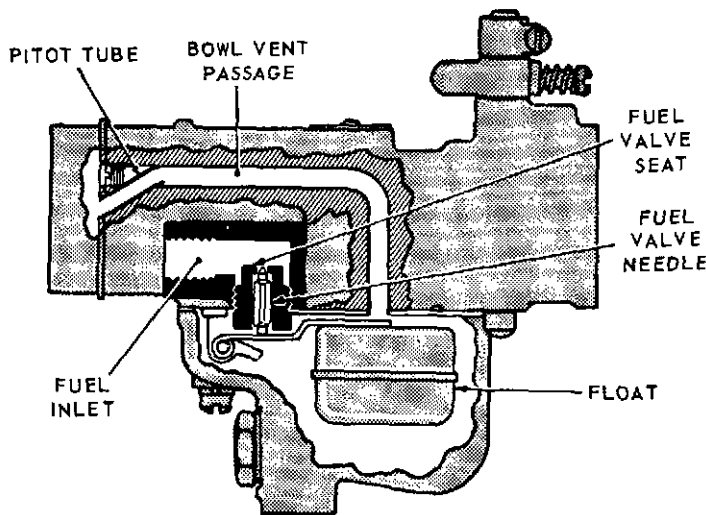

Fig. 1 FUEL SUPPLY SYSTEM

OPERATION

FUEL SUPPLY SYSTEM (Fig. 1)

Fuel under normal pressure entering the float chamber through the fuel valve seat is controlled by the twin float which, moving on its axle, closes the needle valve when the fuel reaches the proper level in the bowl.

IDLE SYSTEM (Fig. 2)

At idling speeds the throttle plate is almost closed, thus a very high suction exists at the edge of the throttle plate where the idle discharge holes are located. All fuel for idling and part throttle operation is supplied through the

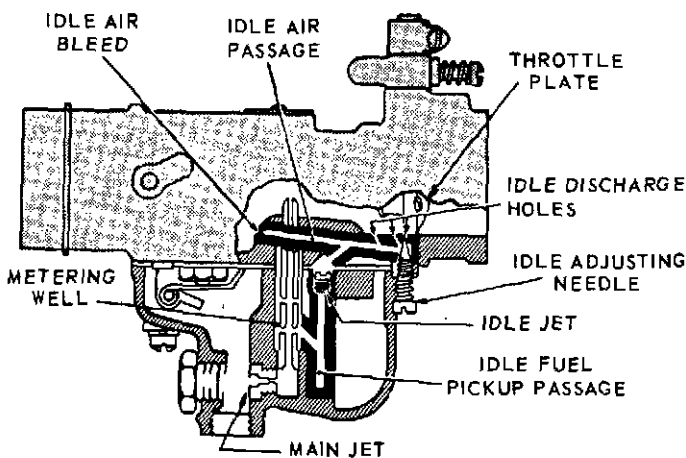

Fig. 2 IDLE SYSTEM

main jet. Fuel from the float chamber flows through the main jet into the metering well. Fuel for idling is drawn from this well through the calibration, or metering orifice, in the center of the idling jet. As the fuel reaches the idling channel it is mixed with air which is admitted through a calibrated orifice in the channel from the inside of the air intake to form an emulsion. This emulsion is discharged into the air stream, to form the idling mixture, through two holes one of which is controlled by the idle adjusting needle. Turning the adjusting needle counter-clockwise (out) permits more of the emulsion to reach the air stream and make the idling mixture richer while turning the needle in (clockwise) cuts off the amount of the emulsion reaching the air stream and makes the mixture leaner.

HIGH SPEED SYSTEM (Fig. 3)

As the throttle is opened, the suction on the idling system diminishes, but the increased volume of air entering the engine through the venturi creates sufficient vacuum (suction) on the discharge jet to draw an emulsion of fuel and air from the metering well which receives its fuel from the main jet and its air from the well vent. The flow characteristics of the discharge jet are influenced by the size, location, and number of holes in the sides of that part of the jet which is in the metering well, as well as by

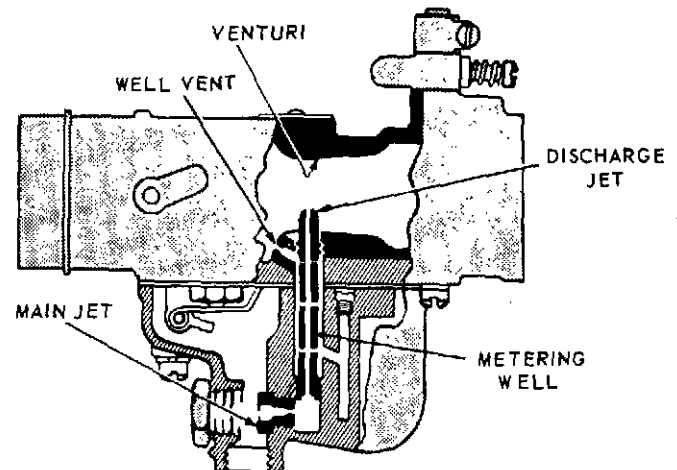

Fig. 3 HIGH SPEED SYSTEM

the sizes of the discharge jet orifice, the size of the main jet, and the size of the well vent. The well vent is located in the air intake and permits air to enter the top of the metering well around the outside of the discharge jet. The flow of fuel through the main jet is controlled by the size of main jet opening.

CHOKE SYSTEM (Fig. 4)

Starting a cold engine requires a much richer mixture of fuel and air. Moving the choke lever to close the choke plate restricts the air entering the carburetor (except at the pitot tube, Fig. 1, to the bowl vent) and increases the suction on the idling system which makes the mixture richer.

STARTING THE ENGINE

Before cranking the engine, the carburetor throttle should be opened a little to expose both idle discharge holes to suction. The choke should be fully closed until the engine starts, then opened a little to prevent stalling from being over-choked, then when the engine is fully warmed up the choke can be returned to wide open position and the throttle closed to the idling position.

ADJUSTMENTS

Adjust the throttle stop screw to obtain the desired idling speed by turning screw in (clockwise) to increase speed and out (counter-clockwise) to decrease engine speed.

Adjust the idle adjusting needle to obtain smooth idling of the engine at idling speed. Turn the needle out (counterclockwise) to make the mixture richer, and in (clockwise) to make it leaner.

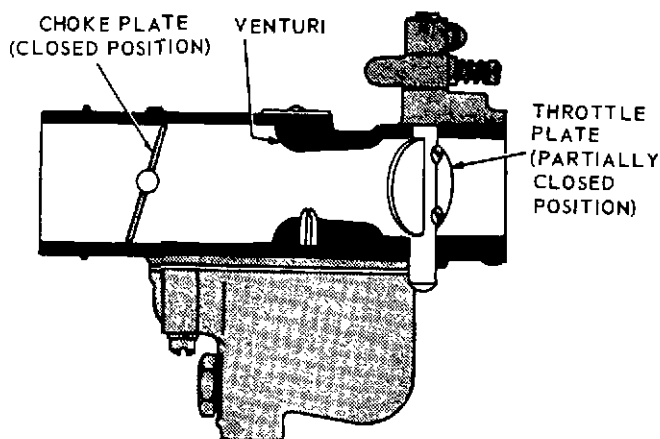

Fig. 4 CHOKE SYSTEM

SERVICE AND REPAIR PROCEDURE

IDENTIFY CARBURETOR

Check the numbers on the metal identification disc pinned to the top of the throttle body or indented in it. The plain number is the Zenith assembly number, the number with the letter "L" pre-fixed to it is Wis-Con Total Power's part number for the complete assembly.

EXPLODED VIEW (Page 3)

The exploded view identifies the serviceable component parts of the carburetor and shows their relationship to the complete assembly. Use the key numbers on the exploded view to identify and locate parts when performing both the disassembly and assembly operations.

DISASSEMBLY

SEPARATE CARBURETOR BODIES

Remove the three bowl assembly screws (45, 46) and separate fuel bowl (39) from throttle body (26).

DISASSEMBLE FUEL BOWL

1. Remove the main jet plug (43) and fibre washer (42), using a 9/16" open end wrench.
2. Remove the main jet (41) and fibre washer (40), using Zenith Tool No. C161-83 main jet wrench.
3. Remove the Idle Jet (38), using a small screwdriver.
4. Remove the bowl drain plug (44).

DISASSEMBLE THROTTLE BODY

1. Remove the float axle (35) by pressing against the end with the blade of a screwdriver.
2. Remove the float (36).
3. Remove the fuel valve needle (31), using the fingers.
4. Remove the fuel bowl to throttle body gasket (37).
5. Remove the main discharge jet (32), using a small screwdriver.
6. Remove the fuel valve seat (31) and fibre washer (30), using Zenith Tool No. C161-85.
7. Remove the idle adjusting needle (17) and spring (18).

CLEANING

Thoroughly clean all metal parts in Bendix Metalclene or Speedclene and rinse in cleaning solvent. Blow out all passages in throttle body and fuel bowl with reduced air pressure. Be sure all carbon deposits have been removed from throttle bore and idle discharge holes. Reverse the flow of compressed air through all passages to insure the removal of all dirt. **NEVER USE A DRILL OR WIRE TO CLEAN OUT JETS OR IDLE HOLES.**

INSPECTION OF PARTS

1. Float Assembly – Replace if loaded with gasoline, damaged or if float axle bearing is worn excessively. Inspect float lever for wear at point of contact with fuel valve needle. Replace if wear is excessive.
2. Float Axle – Replace if any wear has occurred on the bearing surface.
3. Fuel Valve (Needle & Seat) Assembly – Replace as a complete unit. Wear of any of these parts can seriously affect the operation of the float.
4. Idle Adjusting Needle – Inspect tapered end of the needle to make sure it is smooth and free of grooves. Replace if pitted or grooved.
5. Gaskets, Seal and Retainer – Replace all gaskets, throttle shaft seal and retainer each time the carburetor is overhauled.
6. Check Specifications. Verify the correctness of the following parts. Numbers will be found on the parts. Main Jet, Idling Jet and Fuel Valve.

REASSEMBLY

ASSEMBLY OF THROTTLE BODY

1. Install the fuel valve seat (31) and fibre washer (30), using Zenith Tool No. C161-85.
2. Install the main discharge jet (32), using a small screwdriver.
3. Install fuel valve needle in seat (31), followed by float (36) and float axle (35). NOTE: Insert tapered end of float axle (35) into float bracket on side opposite slot and push through the other side. Press float axle (35) into slotted side until the axle is centered in bracket.

4. FLOAT SETTING

- a. **Fuel Level.** Check position of float assembly (36), for correct measurement to obtain proper fuel level by using a depth gage. NOTE: Do not bend, twist, or apply pressure on the float body.
 - b. With bowl cover assembly (26) in an inverted position, viewed from free end of float (36), the float body must be centered and at right angles to the machined surface. The float setting is measured from the machined surface (no gasket) of float bowl cover to top side of float body at highest point. This measurement should be 31/32", plus or minus 1/32".
 - c. **Bending Float Lever.** To increase or decrease distance between float body (36) and machined surface (26) use long nosed pliers and bend lever close to float body. NOTE: Replace with new float if position is off more than 1/16".
5. Install throttle body to fuel bowl assembly gasket (37) on machined surface of throttle body (26).
 6. Install idle adjusting needle (17) and spring (18). Screw needle IN (clockwise) until it seats lightly against the idle discharge hole, then back it out 1/2 turns as a preliminary idle adjustment.

REASSEMBLE FUEL BOWL

1. Install the main jet (41) and fibre washer (40), using Zenith Tool No. C161-83 main jet wrench.
2. Install the main jet hex plug (43) and fibre washer (42), using a 9/16" open end wrench.
3. Install the idle jet (38), using a small screwdriver.
4. Install the bowl drain plug (44).

REASSEMBLE CARBURETOR BODIES

Install the three bowl assembly screws (45, 46) through the fuel bowl and into the throttle body and draw down firmly and evenly.

SPECIAL TOOLS

The special tools recommended are:

1. C161-83 Main Jet Wrench.
2. C161-85 Fuel Valve Seat Wrench.

CARBURETOR

ZENITH MODEL 68-7

The Zenith 68-7 Series carburetor is of an up-draft single venturi design with a 1" S.A.E. barrel size and a 7/8" S.A.E. flange. The carburetors are made with selective fuel inlet, and with or without a main jet adjustment. These carburetors are "balanced" and "sealed", and the semi-concentric fuel bowl allows operation to quite extreme angles without flooding or starving.

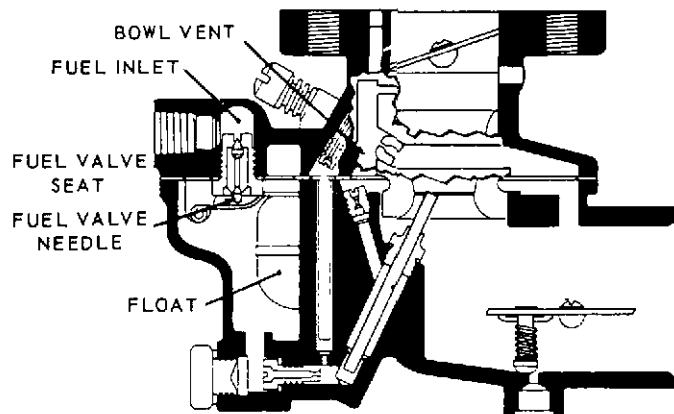

Fig. 1

Fuel supply system, Fig. 1, is made up of a threaded fuel inlet, fuel valve seat, fuel valve needle, float and fuel bowl. Fuel travels through the fuel valve seat and passes around the fuel valve and into the fuel bowl. The level of the fuel in the fuel chamber is regulated by the float through its control of the fuel valve. The fuel valve does not open and close alternately but assumes an opening, regulated by the float, sufficient to maintain a proper level in the fuel chamber equal to the demand of the engine according to its speed and load.

The inside bowl vent as illustrated by the passage originating in the air intake and continuing through to the fuel bowl, is a method of venting the fuel bowl to maintain proper air fuel mixtures even though the air cleaner may become restricted. This balancing is frequently referred to as an "inside bowl vent".

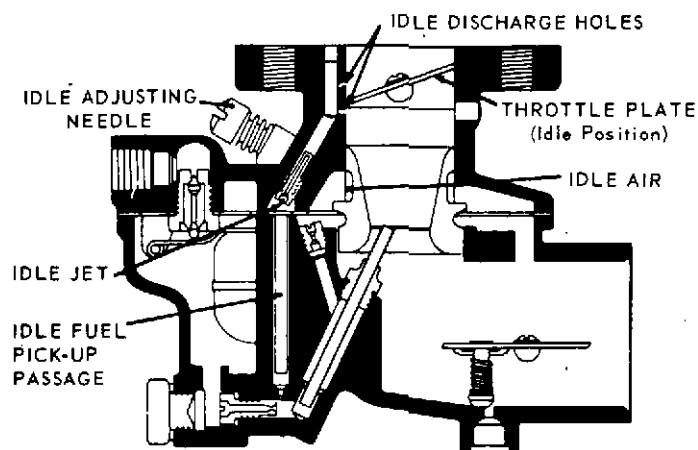

Fig. 2

Idle system, Fig. 2, consists of two idle discharge holes, idle air passage, idle adjusting needle, idle jet, and fuel pick-up passage. The fuel for idle is supplied through the main jet to a well directly below the main discharge jet. The pick-up passage is connected to this well by a restricted drilling at the bottom of this passage. The fuel travels through this channel to the idle jet calibration. The air for the idle mixture originates back of (or from behind) the main venturi. The position of the idle adjusting

WISCONSIN L-63 SERIES

needle in this passage controls the suction on the idle jet and thereby the idle mixture. Turning the needle in closer to its seat results in a greater suction with a smaller amount of air and therefore a richer mixture. Turning the needle out away from its seat increases the amount of air and reduces the suction, and a leaner mixture is delivered. The fuel is atomized and mixed with the air in the passage leading to the discharge holes and enters the air stream at this point.

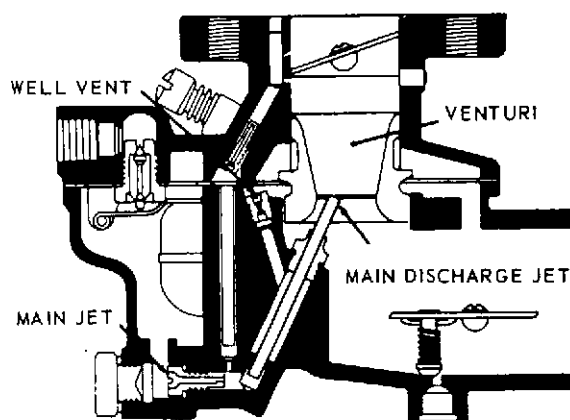

Fig. 3

High speed system, Fig. 3, controls the fuel mixture at part throttle speeds and at wide open throttle. This system consists of a venturi, controlling the maximum volume of air admitted into the engine; the main jet, which regulates the flow of fuel from the float chamber to the main discharge jet; the well vent, which maintains uniform mixture ratio under changing suction and engine speeds; and a main discharge jet, which delivers the fuel into the air stream.

The main jet controls the fuel delivery during part throttle range from about one-quarter to full throttle opening. To maintain a proper mixture, a small amount of air is admitted through the well vent into the discharge jet through air bleed holes in the discharge jet at a point below the level of fuel in the metering well.

The passage of fuel through the high speed system is not a complicated process. The fuel flows from the fuel chamber through the main jet and into the main discharge jet where it is mixed with air admitted by the well vent, and the air-fuel mixture is then discharged into the air stream of the carburetor.

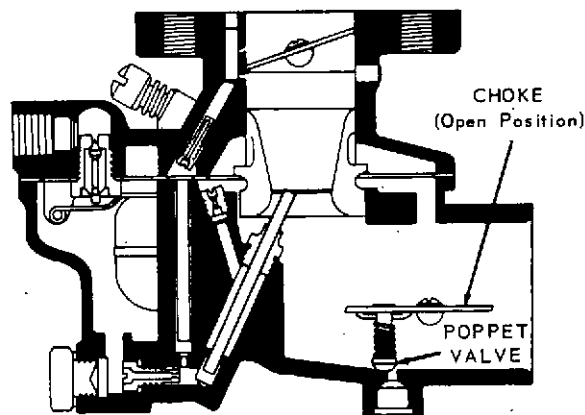

Fig. 4

Choke system, Fig. 4, consists of a valve mounted on a shaft located in the air entrance and operated externally by a lever mounted on the shaft. The choke valve is used to restrict the air entering the carburetor. This increases the suction on the jets

when starting the engine. The choke valve is of a "semi-automatic" type, having a poppet valve incorporated in its design, which is controlled by a spring. The poppet valve opens automatically when the engine starts and admits air to avoid over-choking or flooding of the engine. The mixture required for starting is considerably richer than that needed to develop power at normal temperatures. As the engine fires and speed and suction are increased, the mixture ratio must be rapidly reduced. This change is accomplished through adjustment of the choke valve and the automatic opening of the poppet valve to admit more air when the engine fires.

FLOAT SETTING, Fig. 5

If float position is not to the dimension shown, use a long nose pliers and bend lever close to float body, to obtain correct float setting.

FUEL LEVEL

The liquid level in float chamber is $17/32$ to $19/32$ inch below top of float bowl. This level was established with a #35 fuel valve seat at $1\frac{1}{2}$ p.s.i. and a sight tube approximately $1/4$ to $9/32$ inch i.d.

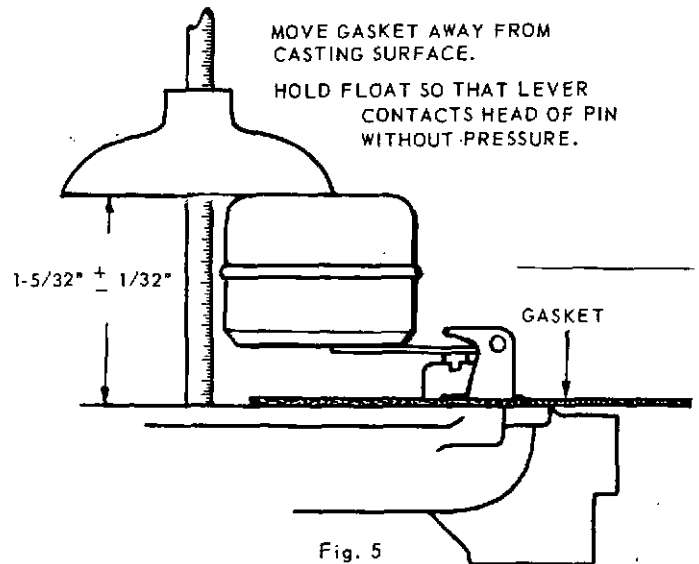

WALBRO CARBURETOR Model LUB

SERVICE INSTRUCTIONS For WISCONSIN Engine Model VH4D

OPERATION, Fig. 1

Fuel is gravity fed or pumped through the gas line from the tank to Inlet fitting (1), through inlet needle Valve seat (2) and into the fuel bowl. As the level in fuel bowl increases, the Float (3) rises, shutting off the fuel supply by forcing needle valve into Valve seat (2). As fuel is being consumed, the float drops and allows additional fuel to enter the bowl through the valve seat. Internal Air vent (7) provides clean air to balance atmospheric pressure in fuel bowl.

WHEN STARTING; the Choke valve (5) is closed and the Throttle valve (10) is wide open causing an abnormally high suction. This high vacuum demand draws fuel and air from both idle and main systems for ease in cold starts.

Fuel from the bowl enters the Main metering jet (4), then up through Main nozzle (9) where it combines with air from Nozzle well air-vent (6). This mixture passes thru Venturi (8) and blends with fuel/air mixture from Air vent (15) and Idle holes (11) and (12) to provide a highly volatile rich mixture for starting.

AT IDLE SPEEDS; the Throttle valve (10) remains closed, exposing only the Idle hole (11) from which a fuel/air mixture is drawn. Air volume is closed off up to the idle hole by the throttle valve as the Choke valve (5) is now open. The Idle adjusting needle (14) regulates the amount of fuel/air mixture to the Idle hole (11), from Idle air vent (15) and Idle fuel channel (16), to meet various engine operating conditions.

AT HIGH SPEED, or full throttle operation; gradual acceleration is obtained when the Throttle valve (10) is partially opened allowing additional fuel/air mixture from the Idle hole (11) and Part throttle hole (12) to enter the engine combustion chamber, causing the engine to run faster. As the throttle valve opening is increased and the engine demands a greater fuel/air volume, the Nozzle (9) begins to satisfy this requirement beyond the idle hole and part throttle hole capacities.

After the acceleration assist from the idle system; at full throttle the complete idle circuit is reversed, as air only, in place of the fuel/air mixture, is drawn through the Idle holes (11), (12), and Channel (16), to Nozzle (9), where it is blended with fuel drawn from float chamber thru Jet (4).

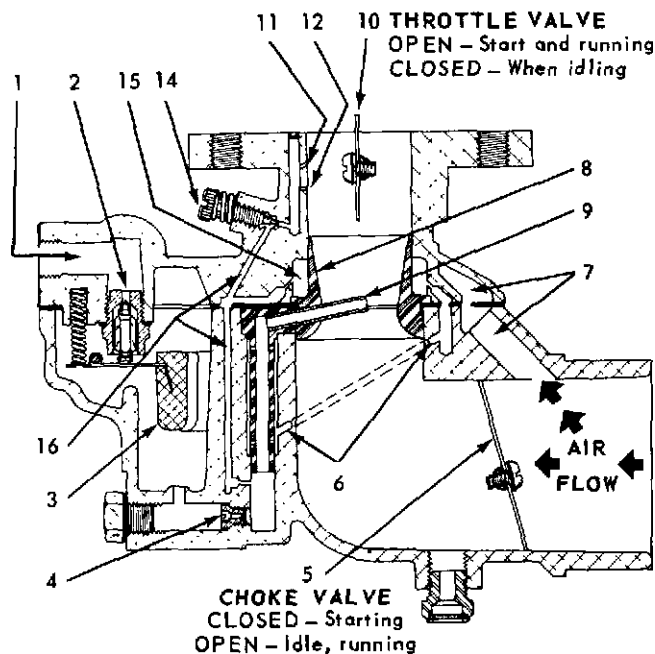

Fig. 1

CARBURETOR TROUBLES CAUSES AND REMEDIES

Dirt is the major cause of field service carburetor problems. An adequate Fuel Filter must be used between the tank and carburetor, and should be serviced frequently. Service Air Filter daily - Keep carburetor and linkage free of dirt.

FUEL LEAKS FROM CARBURETOR

Float level set too high: Remove bowl, invert carburetor and set float. See Fig. 2 and Float Setting Instructions, page 2.

Dirt under inlet needle valve: Remove inlet valve, clean seat by rinsing in mild solvent or clean fuel, and blow off with compressed air.

Bowl vent plugged: Remove bowl and blow clean with compressed air.

Collapsed float, caused by blowing assembled carburetor with compressed air: Replace float.

Carburetor gummed from storage - float stuck: Remove fuel bowl and clean.

ENGINE SMOKES AND RUNS RICH

Dirty air filter: Clean per instructions.

Improper adjustment: Set Idle Needle $1 \pm 1/8$ turns open from seat. Refer to Adjustment Instruction, page 2.

Bowl to body gasket leaks: Tighten securely, or replace.

Air vent in carburetor plugged: Remove fuel bowl and idle needle. Clean air and idle channels thoroughly with compressed air.

ENGINE RUNS LEAN

Improper adjustment: Set Idle Needle $1 \pm 1/8$ turns open from seat. Refer to Adjustment Instructions, page 2.

Idle holes plugged. Dirt in fuel delivery channels: Remove fuel bowl and idle needle. Clean thoroughly with compressed air.

Low fuel level: See Fig. 2 and Float Setting Instructions, page 2.

Fuel filter plugged: Remove and clean.

ENGINE STARTS HARD

Improper adjustment: Set Idle Needle $1 \pm 1/8$ turns open from seat. Refer to Adjustment Instructions, page 2.

No fuel in carburetor: Check carburetor drain plug. Clean tank, filter and carburetor. Check fuel lines for obstructions, and test fuel pump.

Choke valve not closing: Check linkage for proper travel.

GOVERNOR SURGE

Governor sticking: Check linkage for binding.

Throttle shaft and valve binding: Remove and replace shaft if worn. Clean carburetor body and reassemble throttle shaft.

DISASSEMBLY

Before disassembling: Clean outside of carburetor from all foreign material.

IMPORTANT: When cleaning a completely assembled carburetor do not blow with compressed air, you may collapse the float.

For a complete disassembly, follow the sequence of part reference numbers in the carburetor exploded view, Fig. 3. Nozzle Ref. 9, Fig. 1 is not removable.

IMPORTANT: Before removing Throttle and Choke levers, note their position and location. Optional mounting is available and may differ from exploded view illustration.

CLEANING

Wash all parts in a mild solvent or fuel. Blow air through orifices (holes) and channels in throttle body and fuel bowl. Do not probe with any sharp tools which might damage small metering holes.

REASSEMBLY

Replace all worn or damaged parts — use all new gaskets. Note; Body Gasket (18) is put on before float is assembled, and round opening in gasket fits into groove of Venturi (11).

Be sure that Notch in Venturi is facing toward float needle valve — this is clearance for Main nozzle in throttle body.

Assemble Throttle Valve (8) and Choke Valve (25) with part numbers facing to the outside, when valves are in the closed position.

IMPORTANT: Be careful in tightening brass screws and fittings, so as not to strip threads and screw driver slots.

Tighten firmly but not excessively.

Valve Seat (16) — 40 to 50 inch pounds torque
Main Jet (22) — 50 to 60 inch pounds torque

FLOAT SETTING, Fig. 2

With fuel bowl removed and float assembly in place, turn throttle body upside down so that float assembly is on top. Check float height with a depth gauge. Setting should be 1.010 inch \pm .020 above bowl gasket. If necessary, bend float arm (at float), to obtain correct height.

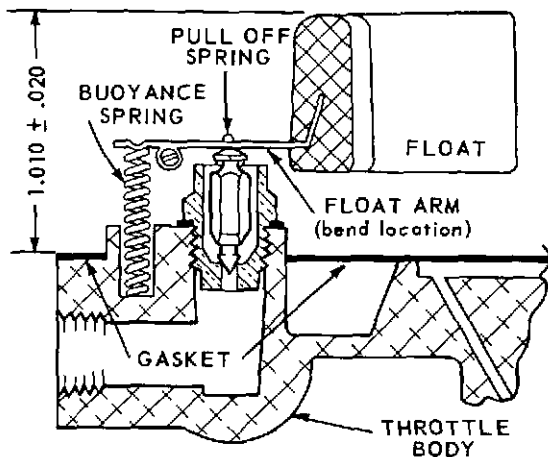

Fig. 2 FLOAT SETTING

ADJUSTMENTS, Fig. 1

Turn Idle speed screw (5), Fig. 3, in until throttle valve is slightly open. With engine warmed up and running, turn adjusting screw in or out as required to obtain desired low idle speed (1000 to 1200 r.p.m.).

The Idle adjusting needle (14) should be seated lightly (clockwise), then backed out $1 \pm 1/8$ turns as a preliminary setting. With engine warmed up and running at about 1200 R.P.M., fine tune idle mixture for smooth steady running.

The Main Metering Jet (4), for high speed operation is fixed (not adjustable), as standard equipment, and used in the majority of engine applications. However, an Adjustable Jet carburetor is available, and the High Speed Adjustment is made by means of the Needle Assembly, Item 22A of Fig. 3, in the following manner:

1. As a preliminary setting, turn needle out from its seat about 1 to $1/4$ turns open.
2. With engine warmed up and running at idle speed, crack throttle open suddenly.
3. If engine hesitates before speeding up, open Main Jet Needle $1/8$ to $1/4$ turn. Repeat until engine goes from idle to high speed without hesitation.

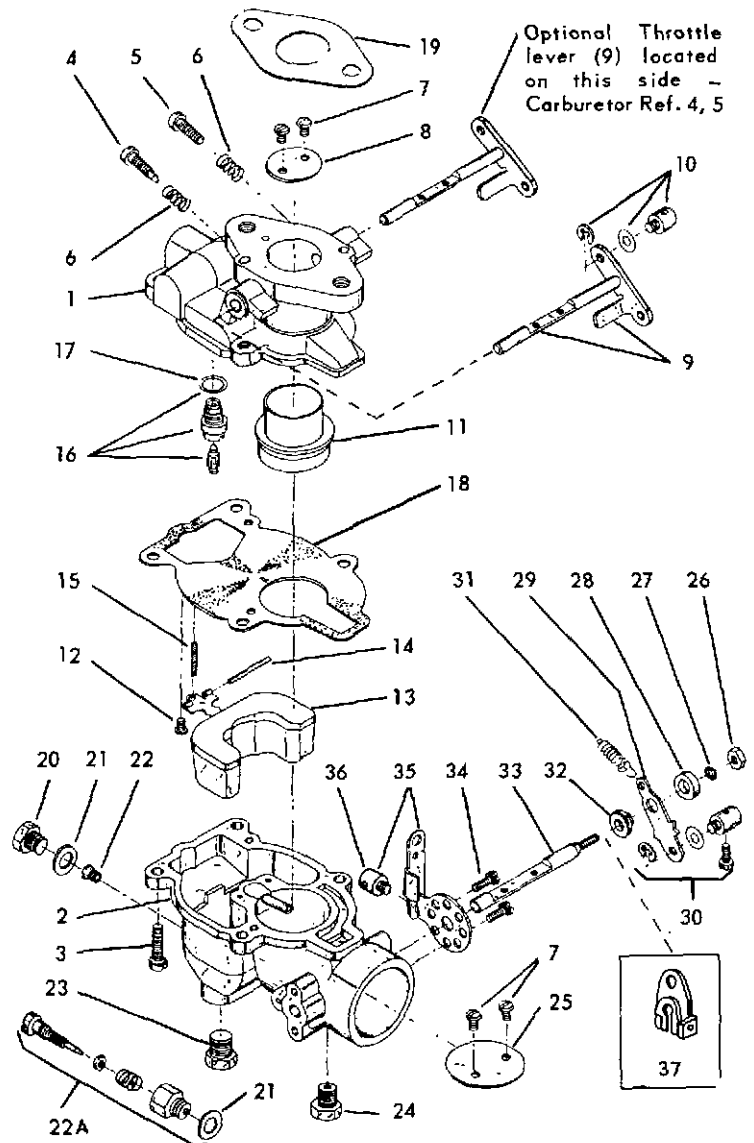
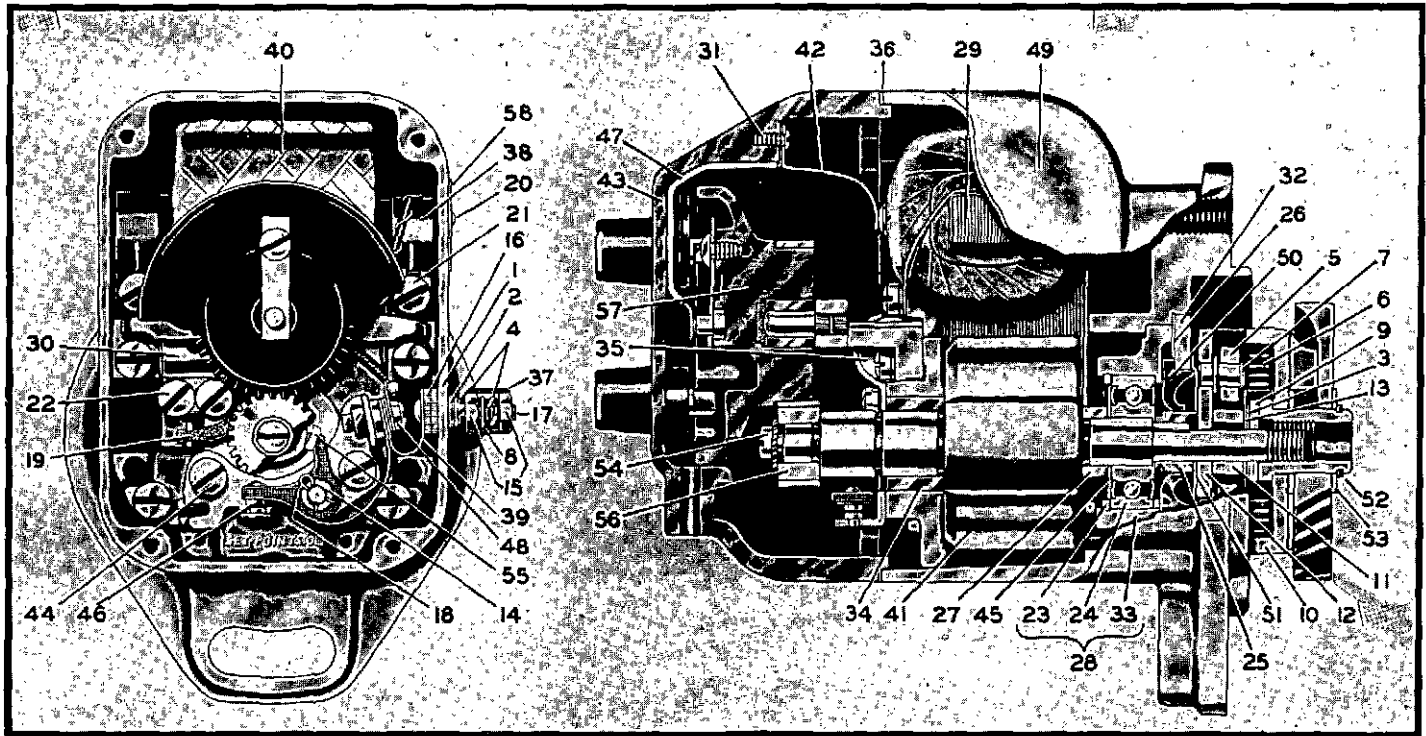

Fig. 3 EXPLODED VIEW
Instructions and Service Parts Illustration

WICO MODEL XHG-4 MAGNETO

FOR WISCONSIN MODEL VH4D ENGINES

SERVICE INSTRUCTIONS



TIMING

The magneto is properly timed to the engine at the factory. If it becomes necessary to retune the magneto to the engine, refer to the diagram and instructions in the engine instruction book.

LUBRICATION

The only lubricating point in the magneto is the cam wiper felt (Ref. No. 19). This felt, which lubricates the breaker arm at point of contact with the cam, should be replaced whenever it is necessary to replace the breaker contacts.

IMPORTANT

Incorrectly adjusted spark plug gaps cause magneto failure more frequently than any other condition.

Spark plugs should be inspected at frequent intervals, the size of the gap should be carefully checked and adjusted and the plugs thoroughly cleaned.

All oil, grease, and dirt should frequently be wiped off the magneto, lead wires, and spark plug insulators. Keeping these parts clean and the spark plugs properly adjusted will improve the engine performance and at the same time will prolong the life of the magneto.

DISTRIBUTOR CAP AND ARM

The distributor cap (Ref. No. 43) may be removed by loosening the 4 screws which hold it in place.

After the cap has been removed, the distributor arm (Ref. No. 57) may be pulled off the bridge. When replacing the arm make sure the timing marks on the distributor arm and the pinion gear are in line.

BREAKER CONTACTS — REPLACEMENT AND ADJUSTMENT

The breaker contacts should be adjusted to .015" when fully opened. To adjust the contacts, loosen the two clamp screws (Ref. No. 44) enough so that the contact plate can be moved.

Insert the end of a small screwdriver in the adjusting slot and open or close the contacts by moving the plate until the opening is .015", measuring with a feeler gauge of that thickness, tighten the two clamp screws.

To replace the contacts remove the breaker spring clamp screw

(Ref. No. 48), the breaker arm lock and washer, (Ref. No. 14) and (Ref. No. 18), then lift the breaker arm from its pivot. Remove the spacing washer and the two breaker plate clamp screws (Ref. No. 44). The breaker plate can then be removed.

If the contacts need replacing it is recommended that both the fixed contact and the breaker arm be replaced at the same time, using replacement breaker set (Ref. No. 46).

After assembly, the contacts should be adjusted as described in *Breaker Contacts* paragraph. The contacts should be kept clean at all times. Lacquer thinner is an ideal cleaner for this purpose. Use WICO tool S-5449, to adjust the alignment of the contacts so that both surfaces meet squarely.

CONDENSER

To remove the condenser (Ref. No. 35), first disconnect the condenser lead by removing the breaker arm spring screw (Ref. No. 48), then remove the two condenser clamp screws (Ref. No. 22), and the condenser clamp (Ref. No. 30). When replacing the condenser make sure it is properly placed between the two locating bosses and that the clamp screws are securely tightened.

COIL AND COIL CORE

The coil and coil core must be removed from the magneto housing as a unit. After the distributor cap and distributor arm have been removed, and the primary wire disconnected from the breaker arm spring terminal by removing screw (Ref. No. 48), take out the two coil core clamp screws (Ref. No. 21), and remove the clamps (Ref. No. 38). The coil and core can then be pulled from the housing. When replacing this group make sure that the bare primary wire is connected under the core clamp screw and that the insulated wire is connected to the breaker arm spring terminal.

REMOVAL OF COIL FROM CORE

The coil (Ref. No. 40) is held tight on the core (Ref. No. 29) by a spring wedge. It will be necessary to press against the coil core with considerable force to remove it from the coil. The coil should be supported in such a way that there is no danger of the primary of the coil being pushed out of the secondary.

MAGNETO SERVICE INSTRUCTIONS FAIRBANKS-MORSE TYPE FM-X4B7A

Y-97 Series

Wisconsin No. Y-97-S2 (With GD-93C-4 DRIVE GEAR) FOR MODEL VH4D

GENERAL DESCRIPTION

Fairbanks-Morse Type FM-X4B7A Magneto is designed and engineered to provide quick easy starting and maximum dependability of operation with minimum service. The compact alnico magnetic rotor assures an intensely hot spark under most operating conditions.

SERVICE PROCEDURE

The first step in magneto field servicing is to examine the magneto for corroded high tension towers, broken wires, or high tension wires not pushed far enough into the magneto tower to make good contact.

Then test the ignition spark while engine is being cranked. If a strong spark is observed, the magneto is not the cause of engine malfunction. If no spark is seen, proceed with servicing magneto.

SERVICING BREAKER POINTS, FIG. 1

Remove the end cap cover, distributor rotor and the end cap. Then inspect the breaker points for pitting, oxidation and shorting. If points are worn or shorted, they should be replaced.

To remove the point set, take out the breaker arm terminal screw releasing the breaker arm spring, coil lead and condenser lead. Remove the fulcrum pin snap ring and slide the breaker arm off the fulcrum pin. Remove the contact support locking screws and lift off the contact support.

The installation of new points is the reverse of the removal. After the points have been installed, they should be adjusted to the correct clearance of 0.015 inch at high point of cam. Be sure the points are clean and bright before adjusting them. Insert a screwdriver in the slot of the support bracket and pivot it between the two small bosses on the bearing support until the desired clearance is obtained. Then clean the points again before sealing the magneto.

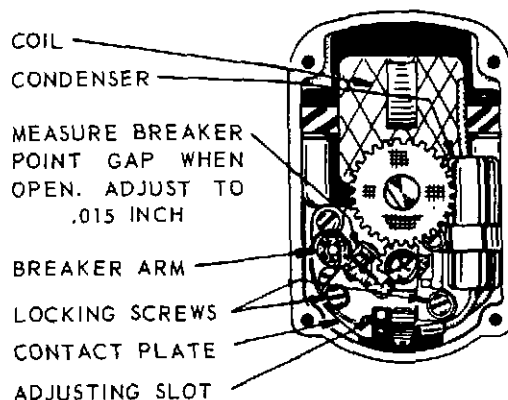

Fig. 1, BREAKER POINT ADJUSTMENT

FIELD SERVICE NOT RECOMMENDED

The cam wick, if dry or hard, should be replaced with a new factory impregnated wick. Other than this the magneto does not require field lubrication. No attempt should be made to oil or grease the magneto bearings. The magneto lubricant should be replaced only during the overhaul of the magneto by a Fairbanks-Morse authorized service station using recommended lubricant and factory engineered parts.

Coil and condenser replacement while simple are not recommended unless adequate test equipment is available. No attempt should be made to remove magnetic rotor from housing unless specific instructions for releasing the shaft are available.

INTERNAL TIMING, FIG. 2

If, for any reason, the magneto has been dismantled to the extent that the distributor gear has been removed the teeth must be properly meshed with those of the magnetic rotor gear upon reassembly. The gear teeth are marked to facilitate internal timing. The single marked tooth of the rotor gear must mesh between the two teeth of the distributor gear designated by the letter C.

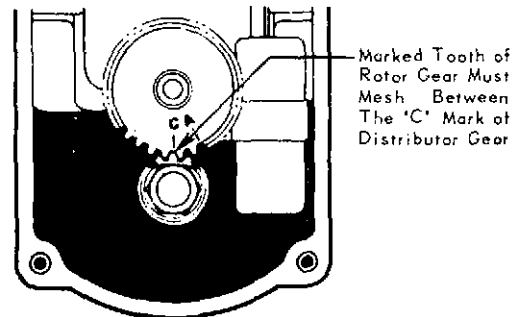

Fig. 2, INTERNAL TIMING GEARS

TIMING THE MAGNETO TO THE ENGINE

If the magneto has been removed from the engine for servicing, the operator must follow the engine manufacturer's instructions for timing the magneto to the engine. Refer to 'Magneto Timing' in engine instruction manual. When installing the magneto on the engine, be sure the magneto is properly attached and that the housing to engine gasket is in good condition.

SPECIAL DRIVE GEAR, FIG. 3

The magneto is equipped with a special drive gear mounted directly on the impulse coupling. If it is necessary to replace the drive gear, special care must be exercised in reassembly. It is possible to be off 180° in timing if gear is improperly mounted.

Assemble gear as follows: Remove magneto end cap cover and turn distributor rotor until it is in firing position for No. 1 cylinder. Retain rotor in this position and fit the drive gear to the impulse coupling lugs so that the prick punch mark on front of gear is located as shown.

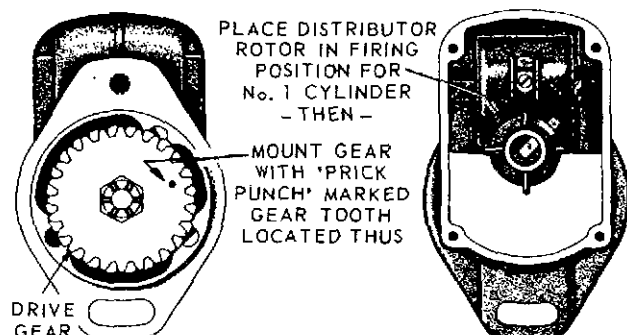

Fig. 3, DRIVE GEAR MARKING AND ASSEMBLY

SOLID STATE IGNITION DISTRIBUTORS

Many new Wisconsin multi-cylinder engines are now being equipped with a solid state ignition distributor. Externally the new solid state ignition distributors are similar in appearance to a conventional point ignition distributor. Internally the major differences are:

1. Distributor cam which opens ignition points has been replaced with a magnet assembly.
2. Ignition points have been replaced with a "Hall effect type" electronic module.

This solid state ignition distributor uses two primary wire leads which attach to the ignition coil. The black or blue lead connects the negative (-) terminal of the ignition coil while the red lead connects to the positive (+) side of the ignition coil.

NOTE: The same Wisconsin coil is used on the solid state and point ignition systems.

TROUBLESHOOTING

The following steps should be performed if the engine's ignition system appears to be not operating properly:

1. Visually inspect plug wires, coil wire, distributor cap and rotor. Replace any components that show deterioration. It is especially important that the cap and plug wires be in good condition, free of oil, grease and moisture.
2. Check for loose or poor connections in ignition circuit. Check battery terminals for corrosion and loose connections.
3. Check battery voltage with engine off. It should be 12 to 15 volts.

If the above items have been checked and found to be proper and the engine's distributor is believed to be faulty, the distributor should be tested.

NOTE: Ignition timing adjustment specifications and procedures for the solid state ignition systems are the same as the corresponding point ignition distributor. An automotive type timing light should be used to check and adjust ignition timing.

TESTING

Testing can be done either with a voltmeter or a 12 volt test light.

VOLT METER TESTING

1. Connect the positive (+) lead of a voltmeter to the negative (-) side of the ignition coil. Ground the negative (-) lead of the voltmeter. Set the voltmeter to DC volts on at least a 15 volt scale.
2. Disconnect the high voltage wire from the center of the distributor cap and ground it to the engine block or chassis.
3. Crank engine.
4. The voltmeter should fluctuate from a range of 1 to 2 volts to a range of 10 to 12 volts as the engine is cranked.
NOTE: On some voltmeters the needle will appear to bounce between 1 and 12 volts.
5. If the voltmeter does not fluctuate, one of the following problems exist:

- a. If the voltmeter shows a constant 0 reading, there is an open circuit somewhere in the primary ignition circuit.
- b. If the voltmeter shows a constant voltage in the 1.0 to 3.5 volt range, the electronic module is shorted out.
- c. If the voltmeter shows a constant voltage equal to the battery voltage, the electronic module has an open circuit and requires replacement.

12 VOLT TEST LIGHT

1. Connect the test light between the positive (+) side of the ignition coil and ground. With the ignition switch in the "on" position the light should light.
NOTE: If there is no voltage present at the positive side of the coil, recheck the circuit from the battery through the ignition switch to the coil.
2. Disconnect the black primary lead going between the ignition coil negative (-) terminal and the distributor. Connect the test light to the negative (-) terminal of the ignition coil. Turn the ignition switch on - the test light should light, if not the ignition coil primary winding is open and the coil should be replaced.

Reconnect the black primary lead of the distributor to the negative (-) terminal of the ignition coil. Connect the test light again to the negative terminal of the ignition coil.

3. Disconnect the high voltage wire from the center of the distributor cap and ground to the engine.
4. Crank the engine.
5. The test light should flicker as the engine is cranked.
6. If the light does not flicker then the distributor electronic module is faulty.

NOTES

To avoid damage to the distributor components the following conditions must be avoided:

1. **REVERSE POLARITY** - **Do not** reverse the battery cables - (this distributor is for negative ground systems only) or the ignition coil wires. Black coil lead to negative terminal of the coil; red lead to positive terminal of the coil.

Some early production distributors have a blue lead instead of a black lead for the negative coil lead.

2. **VOLTAGE SURGES** - **Do not** operate the engine with the battery disconnected. Insure all electrical connections are made properly. Avoid using switches on the engine which cause excessive arcing.
3. Disconnect the ground (negative) cable when charging the battery.
4. **JUMP STARTING** - Only use another 12 volt battery for jump starting - be sure battery polarity is correct (positive to positive, negative to negative.)

NOTE: A HIGH AMPERAGE BOOST CHARGER CAN DAMAGE THE SOLID STATE COMPONENTS WITHIN THE DISTRIBUTOR.

SOLID STATE IGNITION DISTRIBUTORS

SERVICE PARTS LIST PER-LUX YF50S1/YF50AS1 DISTRIBUTOR

DISTRIBUTOR	APPLICATION	ITEM NO.	PART NO.	DESCRIPTION	QTY.
YF50S1	VH4D, SIDE MOUNT	--	20121003	DISTRIBUTOR CAP & GASKET (INCLUDES #1 & #4)	1
YF50AS1	VH4D, TOP MOUNT	1	VENTED DISTRIBUTOR CAP	1
		--	20121006	ROTOR AND SPACER (INCLUDES #2 & #5)	1
2		ROTOR	1
3		20120003	DUST COVER	1
*4		20120010	DISTRIBUTOR CAP GASKET	1
*5		20120011	ROTOR SPACER	1
6		20120004	MAGNET ASSEMBLY	1
7		20120005	ELECTRONIC MODULE (INCLUDES SCREWS)	1
8		20120015	ADVANCE WEIGHTS SET	1
9		20120012	ADVANCE SPRING SET	1
--		20121001	GEAR KIT (INCLUDES #10, #11, #12, #13)	1
10		THRUST WASHER SET (SELECT ONE)	1
11		SPACER (YF50AS1 ONLY)	1
12		GEAR	1
13		ROLL PIN	1
--		YL394-18	WIPE, EXTENSION (NOT SHOWN)	2

* ALSO SOLD SEPARATELY

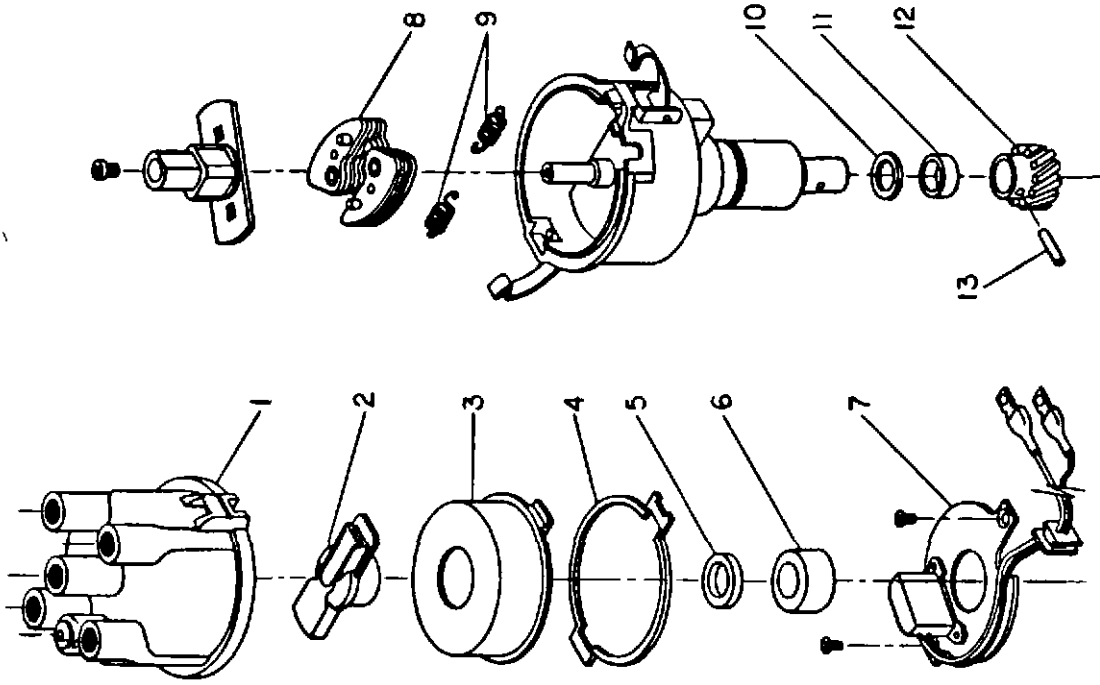

SHAFT END PLAY: .001" - .015"

SERVICE AND PARTS
Available from your Authorized
WIS-CON TOTAL POWER
Service Center

**V
H
4
D**

 **WIS-CON**
TOTAL POWER CORP.

HEADQUARTERS:

3409 Democrat Road P.O. Box 181160 Memphis, Tennessee 38181
Phone: (901) 365-3600 TELEX: 462-1058 (ITT) FAX NO: (901) 369-4050

EUROPEAN:

Rue Joseph Dellandre, 13 B-4053 Chaudfontaine (Liege) Belgium
Phone: (32) (41) 675320 TELEX: 42631 TDY TP B FAX NO: (32) (41) 677987

LIT20129
JAN 1995