

**WISCONSIN
MODELS V465D
V460D, V461D**

REPAIR
MANUAL

V
4
6
5
D

V
4
6
0
D

V
4
6
1
D

 **WIS·CON**
TOTAL POWER CORP.

FOREWORD

Good operation and a planned maintenance program as outlined in this manual are vital in obtaining maximum engine performance and long engine life. The instructions on the following pages have been written with this in mind, to give the operator a better understanding of the various problems which may arise, and the manner in which these problems can best be solved or avoided.

The operator is cautioned against the use of any parts, other than genuine Wis-Con Total Power parts, for replacement or repair. These parts have been engineered and tested for their particular job, and the use of any other parts may result in unsatisfactory performance and short engine life. Wis-Con Total Power distributors and dealers, because of their close factory relations, can render the best and most efficient service.

THE LIFE OF YOUR ENGINE DEPENDS ON THE CARE IT RECEIVES.

The MODEL, SPECIFICATION and SERIAL NUMBER of your engine must be given when ordering parts. The MODEL and SPECIFICATION number are on the name plate. The SERIAL NUMBER is stamped either on the crankcase or the engine's identification tag.

Copy the MODEL, SPECIFICATION and SERIAL NUMBER in the spaces provided below so that it will be available when ordering parts.

MODEL

SPECIFICATION

SERIAL NUMBER

To insure prompt and accurate service, the following information must also be given:

1. State EXACTLY the quantity of each part and part number.
2. State definitely whether parts are to be shipped by express, freight or parcel post.
3. State the exact mailing address.

IMPORTANT

READ THESE INSTRUCTIONS CAREFULLY

All points of operation and maintenance have been covered as carefully as possible, but if further information is required, send inquiries to the factory for prompt attention.

When writing to the factory, ALWAYS GIVE THE MODEL, SPECIFICATION AND SERIAL NUMBER of the engine referred to.

Starting and Operating New Engines

Careful breaking-in of a new engine will greatly increase its life and result in troublefree operation. A factory test is not sufficient to establish the polished bearing surfaces, which are so necessary to the proper performance and long life of an engine. These can only be obtained by running a new engine carefully and under reduced loads for a short time.

- Be sure the engine is filled to the proper level with a good quality engine oil.
- For proper procedures to follow when breaking-in a new engine, see 'Testing Rebuilt Engine'.

The various bearing surfaces in a new engine have not been glazed, as they will be with continued operation, and it is in this period of "running in" that special care must be exercised, otherwise the highly desired glaze will never be obtained. A new bearing surface that has once been damaged by carelessness will be ruined forever.

IMPORTANT SAFETY NOTICE

Proper repair is important to the safe and reliable operation of an engine. This Repair Manual outlines basic recommended procedures, some of which require special tools, devices or work methods.

Improper repair procedures can be dangerous and could result in injury or death.

READ AND UNDERSTAND ALL SAFETY PRECAUTIONS AND WARNINGS BEFORE PERFORMING REPAIRS ON THIS ENGINE

Warning labels have also been put on the engines to provide instructions and identify specific hazards which, if not heeded, could cause bodily injury or death to you or other persons. These labels identify hazards which may not be apparent to a trained mechanic. There are many potential hazards for an untrained mechanic and there is no way to label the engine against all such hazards. These warnings in the Repair Manual and on the engine are identified by this symbol:



Operations that may result only in engine damage are identified in the Repair Manual by this symbol:



Wis-Con Total Power cannot anticipate every possible circumstance that might involve a potential hazard; therefore, the warnings in this manual are not all inclusive. If a procedure, tool, device or work method not specifically recommended by Wis-Con Total Power, Industrial Product Division is used, you must satisfy yourself that it is safe for you and others. You should also ensure that the engine will not be damaged or made unsafe by the procedures you choose.

IMPORTANT: The information, specifications and illustrations in this manual are based on information that was available at the time it was published. The specifications, torques, pressures of operation, measurements, adjustments, illustrations and other items can change at any time. These changes can affect the service given to the product. Get the complete and most current information before starting any job. For parts, service, or information, contact Wis-Con Total Power, Memphis, Tennessee.

WARNING

Most sub-systems used in conjunction with Wis-Con Total Power industrial engines including (but not limited to) radiators, hoses, fans, fuel tanks, fuel lines or other fuel system components, batteries, electrical connections or other electrical components, clutches, transmissions, hydraulic pumps and generators, are not supplied by Wis-Con Total Power. These items are provided by the manufacturer of the end item in which the engine is used.

Some of the dangers associated with servicing such items are generally mentioned in this manual; however, the appropriate handbooks and safety instructions provided by the manufacturer of the end item should always be consulted prior to the undertaking of any work on sub-systems attached to the engine, to avoid any hazards inherent to these sub-systems.

WARNING

Read and observe all individual safety warnings as you use this manual to operate, service or repair your engine.

Always exercise caution whenever working with an engine or any associated system.

Injuries may be caused by lack of care when working with, or near, moving parts, hot parts, pressurized systems, electrical equipment, or fuel systems.

Always wear eye and hearing protection when working on or near engines.

Improper attire such as loose clothing, ties, rings, soft shoes or bare feet could be hazardous and should be avoided when servicing engines.

Use or service of the engine (including the use of modified parts or materials) not in accordance with manufacturer's specifications could damage your engine or cause personal injury.

WARNING

Some equipment and materials used in the overhaul or maintenance of an engine such as machine tools, electrical equipment, compressed air, solvents, gasoline or other fuels may be dangerous and can cause injury. Always observe safety precautions.

SAFETY PRECAUTIONS

- Never fill fuel tank while engine is running or hot; avoid the possibility of spilled fuel causing a fire.
- Always refuel slowly to avoid spillage.
- When starting engine, maintain a safe distance from moving parts of equipment.
- Do not start engine with clutch engaged.
- Do not spin hand crank when starting. Keep cranking components clean and free from conditions which might cause the crank jaw to bind and not release properly. Oil periodically to prevent rust.
- Never run engine with governor disconnected, or operate at speeds in excess of 2400 R.P.M. load.
- Do not operate engine in a closed building unless the exhaust is piped outside. This exhaust contains carbon monoxide, a poisonous, odorless and invisible gas, which if breathed causes serious illness and possible death.
- Never make adjustments on machinery while it is connected to the engine, without first removing the ignition cable from the spark plug. Turning the machinery over by hand during adjusting or cleaning might start the engine and machinery with it, causing serious injury to the operator.
- Precaution is the best insurance against accidents.

*Keep this book handy at all times,
familiarize yourself with the operating instructions.*

Model V465D

3-3/4" Bore — 4" Stroke
177 cu. in. Displacement

Models V461D, V460D

3-1/2" Bore — 4" Stroke
154 cu. in. Displacement

CONTENTS

Air Cleaner, Pre-Cleaner	11,12	General Information and Design	8
Alternator — Belt Driven	34	Generator (Older Models)	15
Bearing — Center Main	11	Governor Adjustment and Operation	17
Breather Cap	10	Horsepower	8
Carburetor Adjustment	12	Ignition Spark	16
Carburetor Service		Ignition System	12
Zenith Model 87A8	35-37	Illustrations, Engine	
Clutch Adjustment	18	Take-off View	5
Clutch Power Take-off	18	Fan End View	5
Clutch Reduction Unit	19	Sectional Views	6,7
Compression — Restoring	16	Lubrication System	11
Cooling	8	Keep Engine Clean	3
Dieseling, Anti-Diesel Valve	10	Lubrication	8
Disassembly and Reassembly	23	Lubrication System	8,11
Accessories	23	Magneto Service	
Camshaft	30	Fairbanks-Morse Type FM-X4B7D	38
Camshaft Gear	30	Oil Filter	10
Carburetor and Manifold	25	Oil — Grade of and Service Classification	9
Center Main Bearing, Roller Type (Older Models)	32	Oil Pressure and Adjustment	10
Center Main Bearing, Shell Type	30	Rotation	8
Connecting Rod and Piston	28	Rocker Arm Covers	17
Crankshaft and Main Bearing Plate	31	Safety Notice	ii-iii
Cylinder Barrel	27	Safety Precautions	2
Cylinder Head	27	Safety Switch — High Temperature	19
Cylinder Shrouding	25	Solid State Ignition Distributors	12, 39-40
Distributor and Accessory Drive	24	Spark Plugs	16
Engine Supports and Oil Pan	26	Starting Motor — Electric	9
Flywheel	23	Starting and Operating Instructions	8
Flywheel Shroud	24	Starting and Operating New Engines	i
Fuel Pump	25	Starting Procedure	9
Gear Cover	25	Stopping Engine — Vapor Lock	10
Gear Train	26	Storage of Engine for Winter	21
Generator	24	Testing Rebuilt Engine	23
Governor	25	Timing	12
Oil Pressure Reducing Valve	32	Distributor Timing	13
Oil Pressure Relief Valve	31	Magneto Timing	15
Oil Pump	26	Neon Lamp Timing	14
Idle Gear and Shaft	31	Timing Instructions	13
Piston	28	Timing Marks	13
Piston Ring and Rod Clearance Chart	29	Troubles — Causes and Remedies	20
Piston Rings	28	Backfiring Through Carburetor	21
Valve Guides and Seat Inserts	30	Compression	20
Valves	29	Engine Stops	21
Rocker Arm Assembly	30	High Oil Pressure	21
Distributor Maintenance	14	Ignition	20
Electric Wiring Circuits	15	Knocking	21
Electrical Wiring Diagrams		Low or No Oil Pressure	21
Distributor Ignition with Alternator	34	Missing	20
Distributor Ignition with Generator (Older Models)	14	Overheating	21
Magneto Ignition	15	Starting Difficulties — Fuel Mixture	20
Firing Order	12	Surging or Galloping	21
Fuel	9	Valves — Grinding	29,30
Fuel Mixture	20	Valve Tappet Adjustment	16
Fuel Pump and Priming	9	Warm-Up Period — Overspeeding	10
Gasoline Strainer	12		

KEEP ENGINE CLEAN PREVENT OVERHEATING

This engine is cooled by a flow of air from a combination fan-flywheel, encased in a sheet metal shrouding. The air is divided and directed by ducts and baffle plates to insure uniform cooling of both banks of cylinders. *If dirt and chaff are allowed to accumulate in the cylinder shrouding or in the V between cylinder banks, the flow of cooling air will be restricted, creating an overheating condition, which could result in costly repairs.*

The rotating screen, illustrated in *Fig. B*, is recommended for engines operating in dusty and dirty conditions. The screen deflects foreign materials away from the air intake opening and helps maintain maximum cooling efficiency. *Keep rotating screen clean.* Even a small section of screen clogged up with dirt will restrict the intake of cooling air enough to bring about an overheating condition.

With reference to Figures A and B; follow these few cleaning and maintenance instructions to insure trouble free and satisfactory engine performance.

1. Cylinder head covers can be removed by releasing snap clips and unscrewing wing nut. Clean out all dirt and chaff from interior of shroud and from between fins of cylinders and heads.
2. Remove dirt and chaff from cylinder heat deflectors at manifold ports.
3. Keep space between cylinder banks clean.

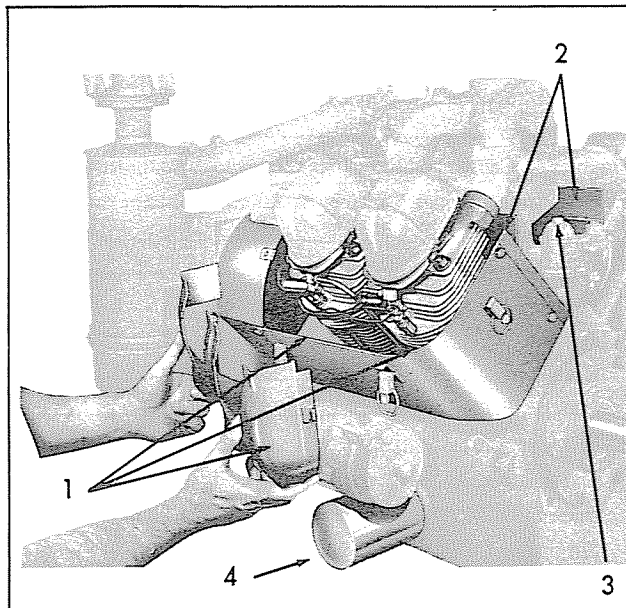

Fig. A

4. Replace this oil filter cartridge every other oil change. If operating conditions are extremely dusty replace cartridge every oil change. See *Oil Filter* instructions, Page 10.
5. Rotating screen must be kept clean. Accumulated dirt caked on screen will restrict cooling.
6. Read instructions on air cleaner regarding its care. The entire air cleaner should be removed from the engine at least once a year, and washed in a solvent to clean out dirt gathered in the back fire trap and filter element.
7. The collector type pre-cleaner must be emptied of accumulated dirt frequently, depending on dust conditions. Do not use oil or water in pre-cleaner, this must be kept dry.
8. Do not allow shrouding to become damaged or badly dented as this will retard air flow.

Never operate engine with air shrouding removed.

Every 4 to 8 hours, depending on dust conditions, check air cleaner and change oil. See Page 12.

Every 8 hours check crankcase oil level. Keep filled to full mark on oil gauge saber, but no more. Every 50 hours drain crankcase and refill with fresh oil. See Lubrication, Pages 8 and 9.

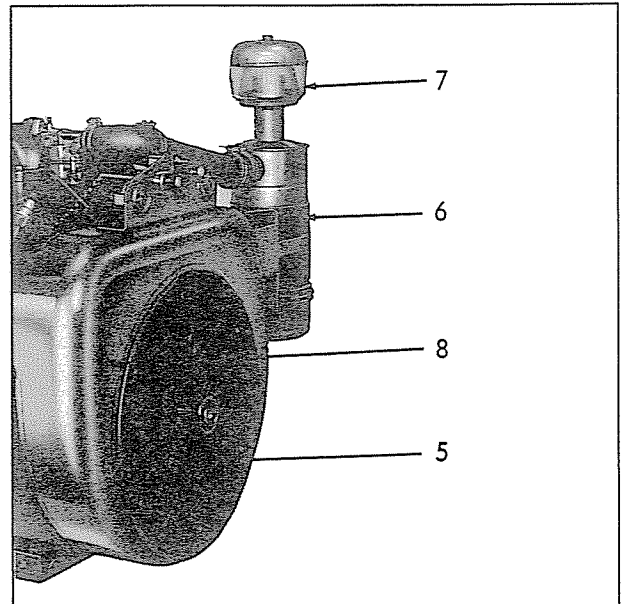

Fig. B

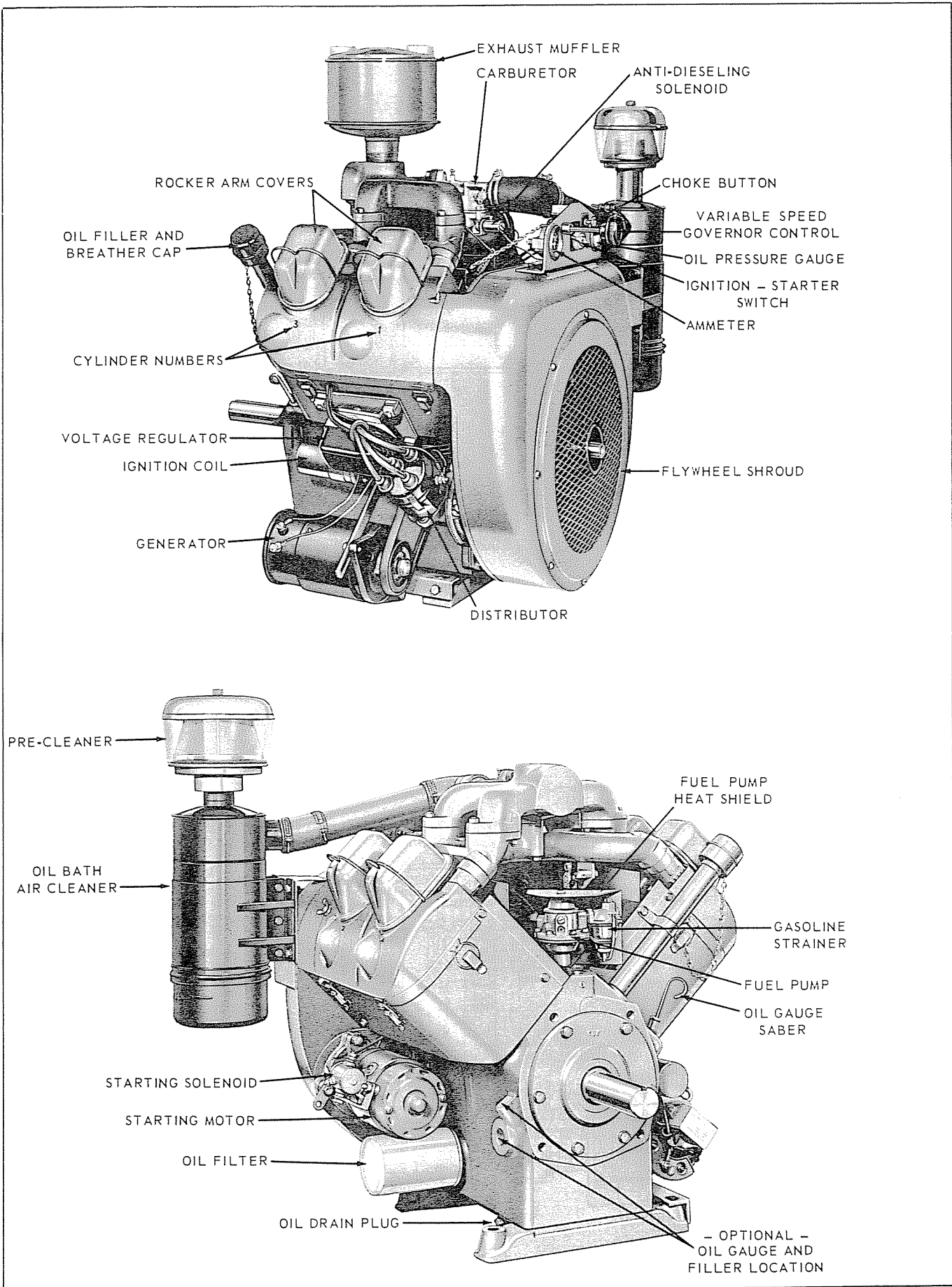
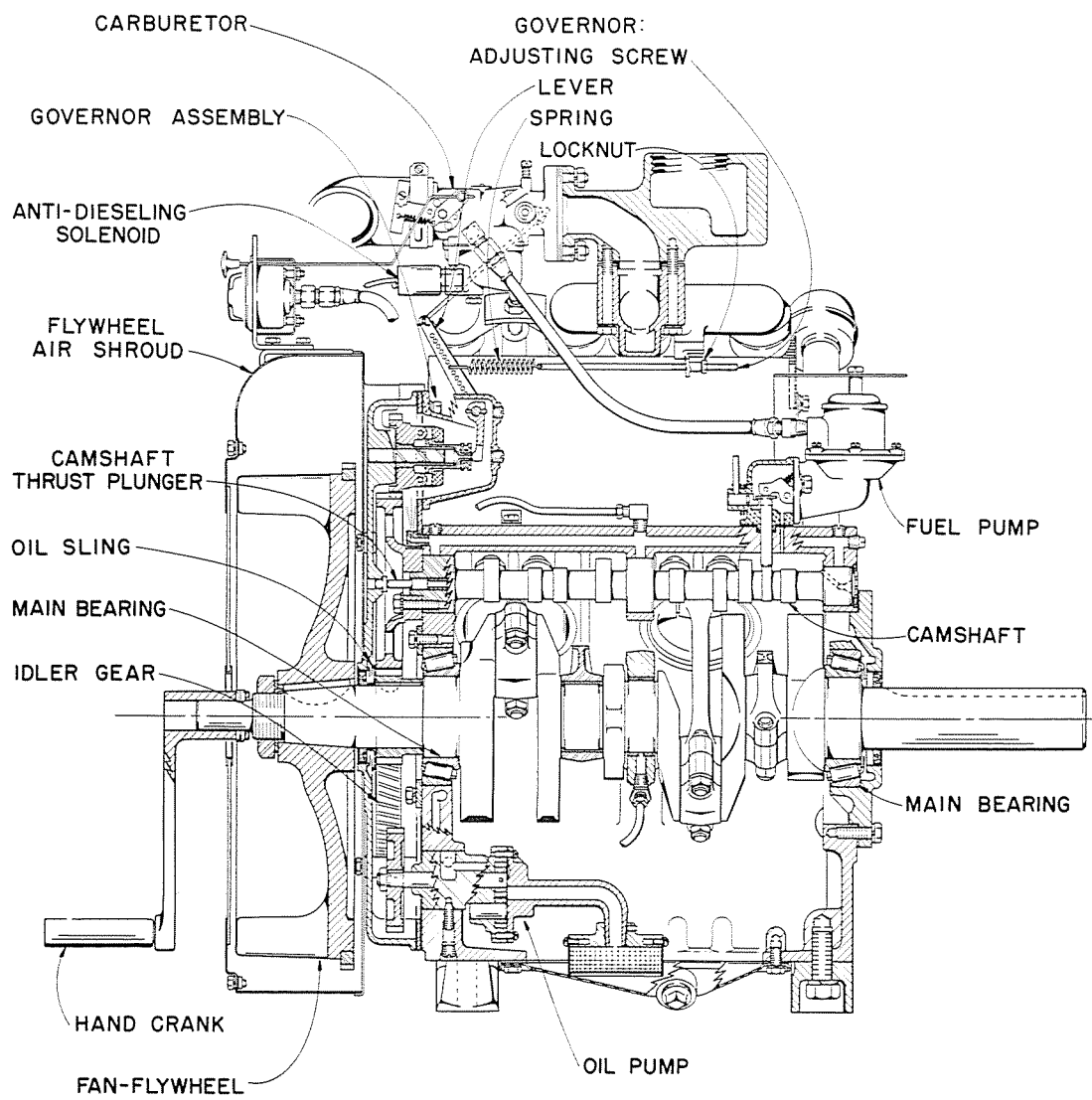
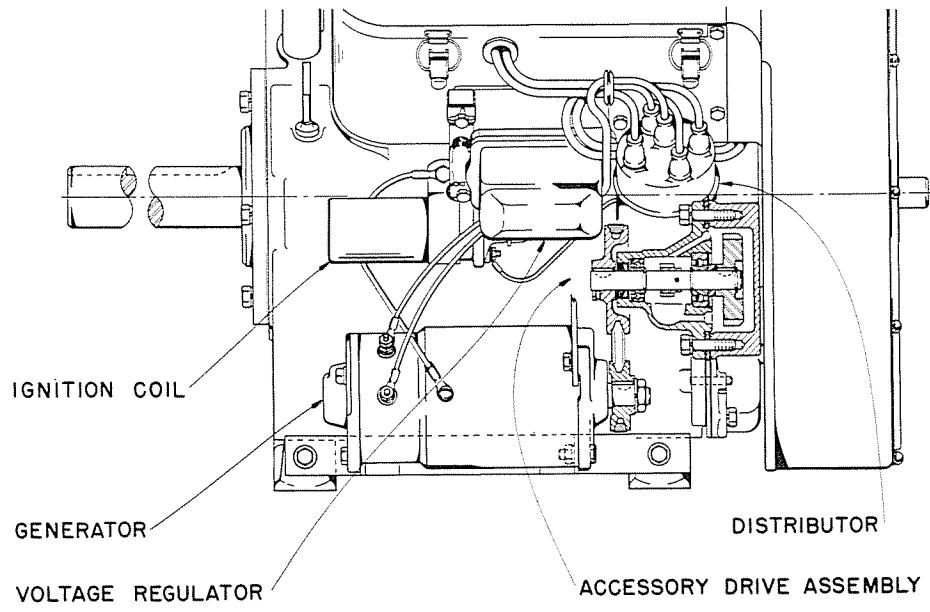
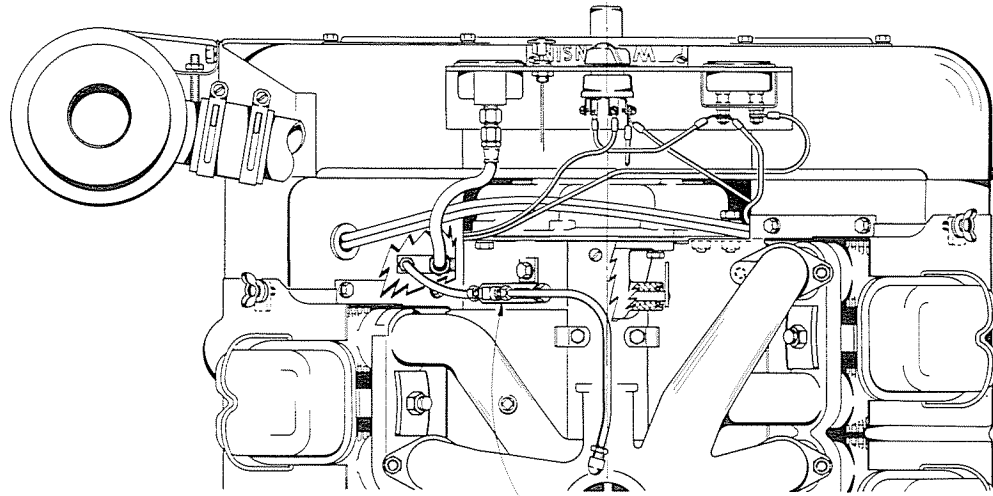

Fig. 1



SECTIONAL VIEWS OF ENGINE



OIL PRESSURE REDUCING VALVE

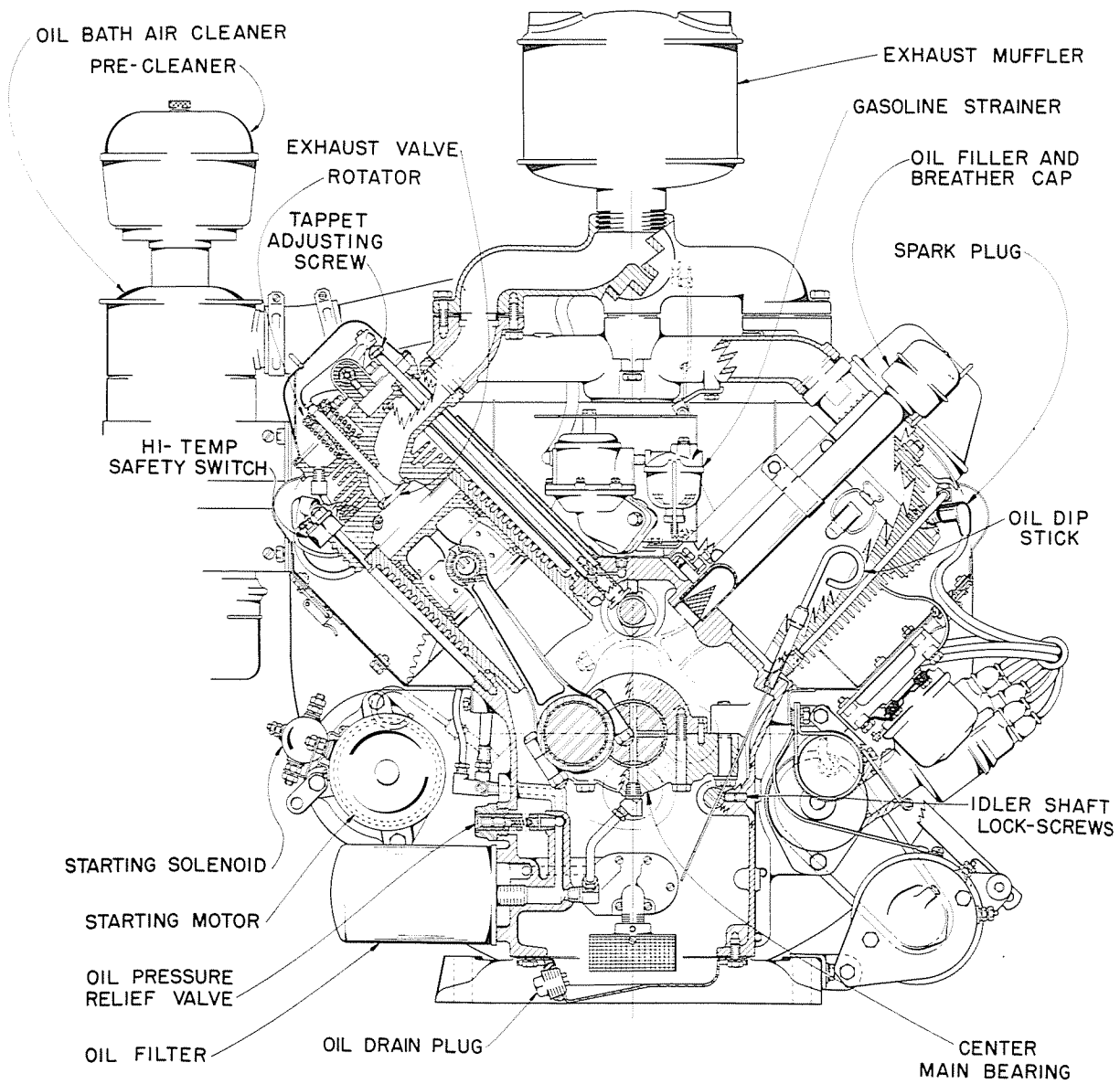

GENERAL INFORMATION AND DESIGN

Wisconsin engines are of the *four cycle type*, in which each of the four operations of *intake, compression, expansion and exhaust* requires a complete stroke. This gives one power stroke per cylinder for each two revolutions of the crankshaft.

COOLING

Cooling is accomplished by a flow of air, circulated over the cylinders and heads of the engine, by a combination fan-flywheel encased in a sheet metal shroud. The air is divided and directed by ducts and baffle plates to insure uniform cooling of all parts.

Never operate an engine with any part of the shrouding removed, — this will retard the air cooling.

Keep cylinder and head fins free from dirt and chaff. Improper circulation of cooling air will cause engine to overheat.

CARBURETOR

The proper combustible mixture of gasoline and air, is furnished by a balanced carburetor, giving correct fuel to air ratios for all speeds and loads.

IGNITION

The spark for ignition of the fuel mixture is directed from the coil to the spark plugs, at the proper time, by a *distributor*. Electric starter and alternator are furnished with distributor ignition.

Magneto ignition can be furnished in place of distributor, when specified. The high tension magneto used, is fitted with an impulse coupling that provides a powerful spark for easy starting.

LUBRICATION SYSTEM

A gear type pump provides pressurized lubrication to the connecting rod bearings, camshaft bearings, tappets, valve train and to an oil spray nozzle in the gear cover. The spray nozzle lubricates the governor and gear train. The oil expelled from these areas form a mist which lubricates the cylinder walls and the anti-friction crankshaft bearings.

All of the circulated oil passes thru a *full-flow oil filter*. Crankcase impurities are collected in the filter element, thereby minimizing friction and reducing wear to critical moving parts of the engine.

GOVERNOR

A governor of the centrifugal flyball type controls the engine speed by varying the throttle opening to suit the load imposed upon the engine. All engines are equipped with either *fixed speed* governors, a *variable speed regulator* to control the governed speed of the engine, or an *idle control*.

ROTATION

The rotation of the crankshaft is clockwise when viewing the flywheel or cranking end of the engine. This gives *counter-clockwise* rotation when viewing the power take-off end of the engine. The flywheel end of the engine is designated the *front end*, and the power take-off end, the *rear end* of the engine.

HORSEPOWER CHART

R.P.M.	V-460D V-461D	V-465D
1600	40.9	41.6
1800	45.6	47.5
2000	50.2	52.4
2200	53.8	56.7
2400	56.8	60.0
2600	58.4	63.0
2800	60.2	64.5
3000	60.5	65.9

HORSEPOWER

The horsepower given in the above chart is for an atmospheric temperature of 60° Fahrenheit, at sea level, and at a Barometric pressure of 29.92 inches of mercury.

For each inch lower Barometer reading, deduct 3½% from above horsepower.

For each 10° higher temperature, there will be a reduction in horsepower of 1%.

For each 1000 ft. altitude above sea level, there will be a reduction in horsepower of 3½%.

The friction in new engines cannot be reduced to the ultimate minimum during the regular block test, but engines will develop at least 85 per cent of maximum power when shipped from the factory. The power will increase as friction is reduced during a few days of operation. The engine will develop approximately 95% of power shown on chart when friction is reduced to a minimum.

For continuous operation, limit to 80% of horsepower shown, as a safety factor.

INSTRUCTIONS FOR STARTING AND OPERATING

LUBRICATION

Before starting a new engine, fill crankcase with the correct grade of lubricating oil, as specified in "Grade of Oil" chart. Fill through the breather tube opening with 6 quarts of oil, and check level by means of the oil gauge saber. When replacing oil filter, an additional 1 quart of oil is required.

For *run-in of new engines*, use same oil as recommended in *Grade of Oil Chart*.

The standard *oil gauge saber* is located on the left hand side, below the oil filler-breather tube. See *Fig. 1*. When specified, a saber can be furnished on the opposite side, behind the starting motor.

High grade oil of the body suited to the requirements of your engine is the most important single item in the economical operation of the unit, yet it is the cheapest item of operating cost. *Select your oil solely on quality and suitability* – never on price – for no one thing is so sure to bring about unsatisfactory performance and unnecessary expense as incorrect lubrication. High-grade highly refined oils, corresponding in body to the S. A. E. Viscosity Numbers listed in *Grade of Oil Chart* will prove economical and assure long engine life.

SERVICE CLASSIFICATION OF OIL

In addition to the S.A.E. Viscosity grades, oils are also classified according to severity of engine service. Use oils classified by the Americal Petroleum Institute as **Service SE, SF or SG**. These types of oil are for engines performing under unfavorable or severe operating conditions such as: high speeds, constant starting and stopping, operating in extreme high or low temperatures and excessive idling.

GRADE OF OIL

SEASON OR TEMPERATURE	GRADE OF OIL
Spring, Summer or Fall + 120°F to + 40°F	SAE 30
Winter + 40°F to + 15°F + 15°F to 0°F Below Zero	SAE 20-20W SAE 10W SAE 5W-20
Use Oils classified as Service SE, SF, SG or CC	
Crankcase Capacity	6 Qts.
Additional for Oil Filter	1 Qt.

For *run-in of new engines*, use same oil as recommended in *Grade of Oil Chart*.

Follow summer recommendations in winter if engine is housed in warm building.

Check oil level every 8 hours of operation.

The old oil should be drained and fresh oil added after every 50 hours of operation.

To drain oil, remove drain plug in oil pan at oil filter side. Oil should be drained while engine is hot, as it will then flow more freely.

FUEL

The fuel tank should be filled with a *good quality* gasoline, free from dirt and water. Some of the poorer grades of gasoline contain gum which will deposit on valve stems, piston rings, and in the various small passages in the carburetor, causing serious trouble in operating, and in fact might prevent the engine from operating at all.

Use only reputable, well known brands of REGULAR GRADE gasoline.

The gasoline should have an octane rating of at least 90. Low octane gasoline will cause the engine to detonate, or *knock*, and if operation is continued under this condition, cylinders will score, valves will burn,

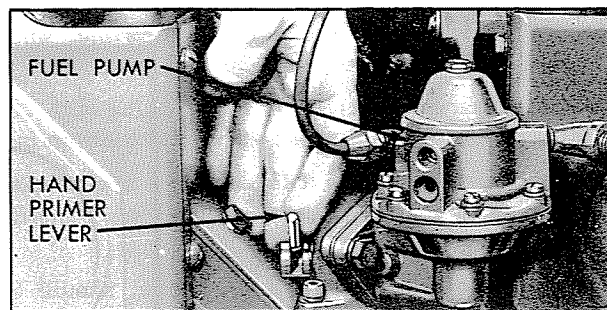

Fig. 2

pistons and bearings will be damaged, etc.

Be sure that air vent in tank cap is not plugged – this would impede the flow of fuel to the carburetor.

FUEL PUMP and PRIMING (Fig. 2)

The diaphragm type fuel pump is actuated by an eccentric on the camshaft, as illustrated in cross sectional view of engine, *page 6*.

Hand Primer for *hand crank engine* is furnished as an option, and is a necessary function when starting a new engine for the first time, or when engine has been out of operation for a period of time. Gravity feed and electric start engines do not require hand priming.

When priming, a distinct resistance of the fuel pump diaphragm should be felt when moving the hand lever up and down. If this does not occur, the engine should be turned over one revolution so that the fuel pump drive cam will be rotated from its upper position which prevents movement of the pump rocker arm.

Assuming the gasoline strainer is empty, approximately 25 strokes of the primer lever are required to fill the bowl. *See Fig. 2*. After strainer bowl is full, an additional 5 to 10 strokes are required to fill the carburetor bowl. When carburetor is full the hand primer lever will move more easily.

STARTING

ELECTRIC STARTING MOTOR

A 12 volt starting motor with an attached starting solenoid is provided as standard equipment on this model engine, unless otherwise specified.

Do not oil Bendix drive. Keep screw threads clean and if necessary, lubricate with powdered graphite.

STARTING PROCEDURE

1. Check crankcase oil level and fuel supply. Open fuel valve.
2. Disengage clutch, if furnished.
3. New engines require priming; refer to "Fuel Pump" paragraph for instructions.
4. Set throttle about 1/2 open if variable speed governor control is furnished; with a two-speed control, start in full load position.
5. Turn *ignition-starting switch* to 'start' position and at the same time pull out choke button only sufficient to start the engine. Release choke button to open position after engine starts, but re-

choke if it tends to stop. **Even a hot engine requires a momentary choking when starting.** When engine starts release switch to 'run' position.

If flooding should occur, continue cranking with the starting motor, but with choke open (choke button in).

After engine starts; allow it to warm up a few minutes before applying load, as prescribed in 'Warm-Up Period' paragraphs.

New engines; started for the first time, should be "run-in" gradually to insure trouble-free service and long engine life. Refer to "Starting and Operation of New Engine" instructions, on the inside front cover of this manual, for correct *running-in* procedure.

WARM-UP PERIOD

The engine should be allowed to warm up to operating temperature before load is applied. This requires only a few minutes of running at moderate speed. **Racing an engine or gunning it,** to hurry the warm-up period, **is very destructive** to the polished wearing surfaces on pistons, rings, cylinders, bearings, etc., as the proper oil film on these various surfaces cannot be established until the oil has warmed up and become sufficiently fluid. This is especially important on new engines and in cool weather.

Racing an engine by disconnecting the governor, or by doing anything to interfere with the governed control engine speed, **is extremely dangerous.** The governor is provided as a means for controlling the engine speed to suit the load applied, and also as a safety measure to guard against excessive speeds, which not only overstrain all working parts, but which might cause wrecking of the engine and possible injury to bystanders.

All parts of the engine are designed to safely withstand any speeds which might normally be required, but it must be remembered that the stresses set up in rotating parts increase with the square of the speed. That means that if the speed is doubled, the stresses will be quadrupled, and if the speeds are trebled, the stresses will be nine times as great.

Strict adherence to the preceding instructions cannot be too strongly urged, and greatly increased engine life will result as a reward for these easily applied recommendations.

STOPPING ENGINE

To stop engine; turn *ignition-starting switch* to 'off' position.

If the engine has been running hard and is hot, do not stop it abruptly from full load, but remove the load and allow engine to run idle at 1000 to 1200 R.P.M. for three to five minutes, depending on how hot the engine has been. This will reduce the internal temperature of the engine much faster, minimize valve warping, and of course the external temperature, including the manifold and carburetor will also reduce faster, due to air circulation from the flywheel.

One of the main troubles caused by the abrupt shutting off of a hot engine is *vapor lock*. This will result

in hard starting, which can be overcome by choking the engine when cranking or waiting until the engine has cooled off sufficiently to overcome the vapor lock.

ANTI-DIESEL VALVE

High compression engines have a tendency to occasionally *diesel*, after the ignition has been shut off. To rectify this condition, an *anti-dieseling solenoid valve* is provided to assure immediate stopping. When the ignition is turned off, the solenoid becomes de-energized and releases a valve that shuts off the fuel supply in the carburetor, thus stopping the engine. **CAUTION: Engine will not operate if ignition wire from anti-diesel solenoid to starting switch is disconnected.**

If solenoid is removed from carburetor for some reason, use a new fibre washer in reassembly, and tighten to 100 inch pounds torque.

OIL FILTER

A *full-flow* oil filter is furnished on this model of engine as standard equipment. Since all of the circulated oil passes thru the filter, it is very important that it be serviced regularly in order to function properly.

When the filter element becomes clogged, the oil bypasses the filter material by means of a relief valve located in the top of the oil filter. *See Fig. 3.* As a result, there is no variation in oil pressure to indicate that the oil filter is clogged and requires replacement. **The oil filter should be replaced after every other oil change. If operating conditions are extremely dusty, replace filter after every oil change.**

The oil filter is easily removed by unscrewing it from its mounting pad on the side of the crankcase. Refer to "Oil Filter" in disassembly instructions. When reassembling a new filter, add a film of oil to the face of the rubber gasket at the base — turn filter to a snug fit, then ½ turn more. **Do not over-tighten.**

Pour 1 additional quart of oil into crankcase when replacing oil filter. Use only a *Wisconsin* oil filter, specially designed for this model of engine. **Refer to parts list for correct service part number.**

BREATHER CAP

The crankcase is ventilated thru a breather cap mounted to the top of the oil filler tube, as illustrated in *Fig. 3.* At every oil change, it is recommended that the cap be cleaned by washing in kerosene.

OIL PRESSURE AND ADJUSTMENT

HIGH PRESSURE SYSTEM

Oil supplied to the center main and connecting rod bearings, at 40 to 45 P.S.I. gauge pressure (was 50 P.S.I.), is controlled by a *pressure relief valve*, properly adjusted at the factory. Readjustment, when necessary, must be made while engine is running. Refer to *Fig. 3* and the following instructions:

The *oil pressure relief valve* is located beneath the starting motor and next to the oil filter. The stub end of the valve is closed off by an *expansion plug*. Remove plug from the end of the valve, then, with a

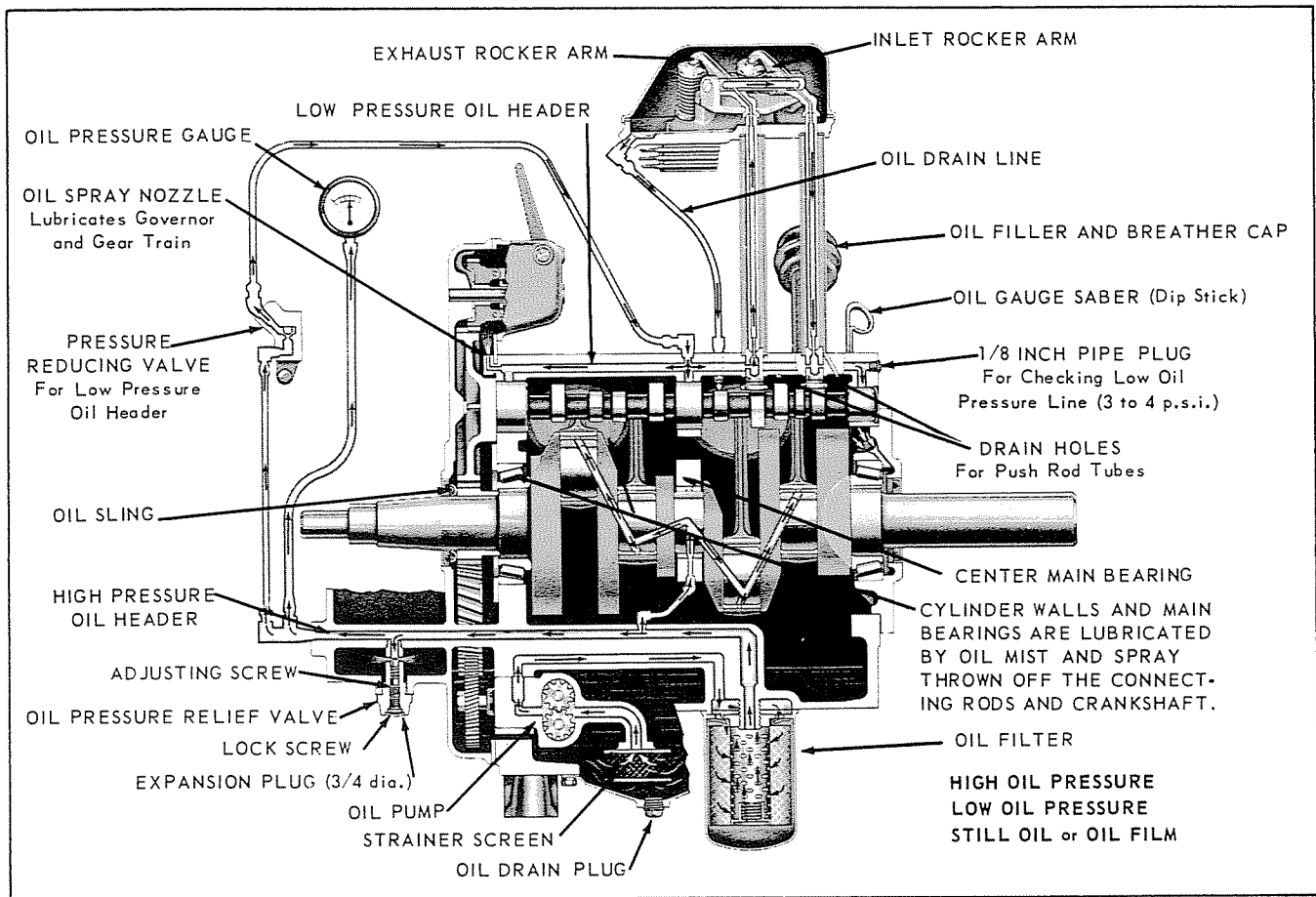

Fig. 3, LUBRICATION SYSTEM

3/16 Allen wrench, remove the outer *lock screw*. With the same wrench, adjust spring tension by means of the *adjusting screw*; turn clockwise to increase gauge pressure, counter-clockwise to reduce pressure.

NOTE: With engine running at 1800 R.P.M. and engine oil hot, adjust oil pressure 40 to 45 P.S.I. Idle engine at 1000 R.P.M., and if oil pressure falls below 15 P.S.I., check for irregularities in the oil pump, bearings and oil connections.

After adjustment is made, mount *outer lock screw* firmly in place. Use a new 3/4 inch expansion plug to seal off any oil which may by-pass the screw threads.

LOW PRESSURE SYSTEM

The upper, or *low pressure oil header*, supplies oil to the camshaft bearings, tappets, valve train and governor-gear train nozzle at 3 to 4 P.S.I., thru a *pressure reducing valve* from the main or *high pressure oil header*. This pressure is not registered on a gauge, but can be checked by connecting a low pressure gauge to the 1/8" pipe tap located at the take-off end of the engine above the camshaft plug. Operate the engine at 1800 R.P.M. when making this check.

The *pressure reducing valve*, mounted on the crankcase in front of No. 2 cylinder beneath the air duct of No. 2-4 bank, is pre-set by the manufacturer (*not adjustable*). If valve becomes faulty it should be replaced with a completely new unit.

CENTER MAIN BEARING (V-465D)

Beginning with serial No. 4904657, a *shell* type *center main bearing* replaces the roller bearing, and lubrication to the connecting rod bearings is modified as follows: Oil pressure to the rods is channeled thru the crankshaft by means of an oil line connection to the *center main bearing* instead of thru a collet on the crankshaft gear. See Fig. 3.

AIR CLEANER

The oil bath air cleaner, illustrated in Fig. 4, must be serviced frequently, depending on the dust conditions in which the engine is operated.

Service daily or twice a day if engine is operating in very dusty conditions. **Once each week**; in comparatively clean conditions.

Remove oil cup from bottom of air cleaner and clean thoroughly. Add the same grade of oil as used in the crankcase, to the *level line* indicated on the oil cup. Detailed instructions are printed on the air cleaner.

Operating the engine under dusty conditions without oil in the air cleaner or with dirty oil, may wear out cylinders, pistons, rings and bearings in a few days time, and result in costly repairs.

Once a year, oftener if conditions are severe, remove air cleaner from engine and soak in solvent to clean out accumulated dirt from element. *Caution:* Do not clean with gasoline, naphtha or benzine.

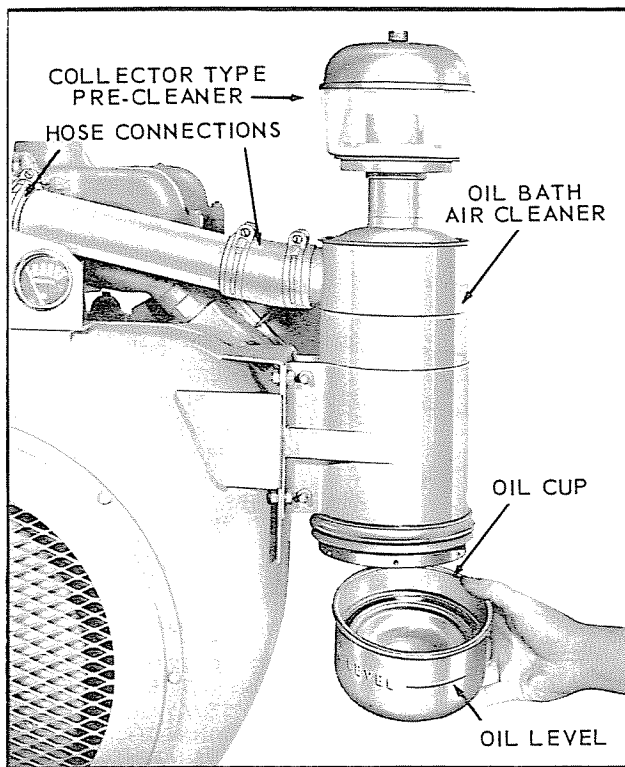

Fig. 4

PRE-CLEANER

The collector type pre-cleaner, mounted to the top of the air cleaner as illustrated in *Fig. 4*, removes the larger dirt and dust particles before the air reaches the main air cleaner.

Clean bowl regularly of accumulated dust and dirt. *Do not use oil or water in pre-cleaner, this must be kept dry.*

Daily attention to the air cleaner and pre-cleaner is one of the most important considerations in prolonging engine life.

GASOLINE STRAINER

The gasoline strainer is very necessary to prevent sediment, dirt and water from entering the carburetor and causing trouble or even complete stoppage of the engine. This strainer has a glass bowl and should be inspected frequently, and cleaned if dirt or water are present.

To remove sediment bowl, loosen nut below bowl and swing wire bail to one side, *see Fig. 5*. There will be less danger of breaking the gasket if the bowl is given a twist as it is being removed. Clean bowl and screen thoroughly. Replace gasket if it has become damaged or hardened. Repair kits are available for service replacement, refer to parts list in rear of manual.

CARBURETOR ADJUSTMENT

The main metering jet in the carburetor is of the fixed type, that is, it requires no adjustment. The idle needle should be adjusted for best low speed operation, while carburetor throttle is closed by hand. For illustrations and more information, see Carburetor

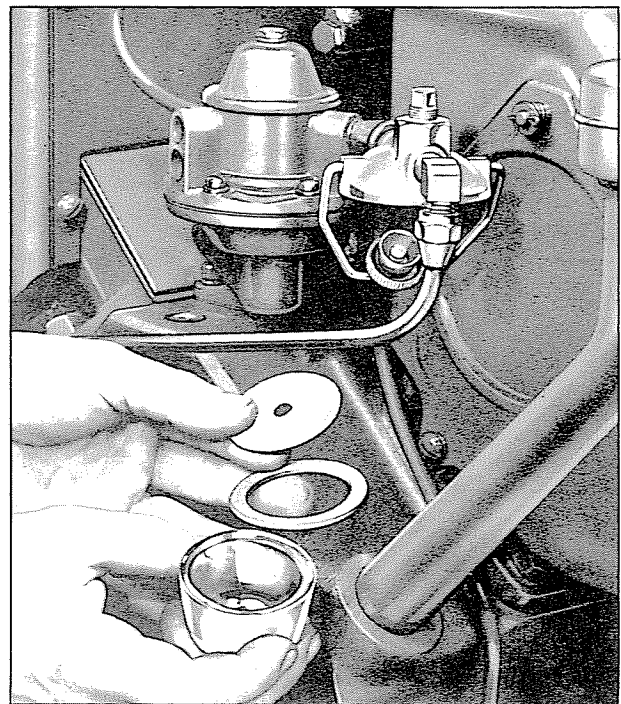

Fig. 5

Manufacturer's Instruction Bulletin in the back of this manual.

IGNITION SYSTEM

A battery ignition system is standard equipment on this model of engine. The distributor is of the automatic advance type and it is driven off an engine speed shaft through a pair of two to one ratio gears, thus driving the distributor rotor at one half engine speed in a counter-clockwise direction when viewed from above.

The running spark advance of the engine is 23° and the distributor is fully advanced at 2000 R.P.M.

Engine must be running at 2000 R.P.M. or over, when checking or adjusting spark advance.

SOLID STATE IGNITION DISTRIBUTORS

Many Wisconsin engines are now being equipped with a solid state ignition distributor. Detailed troubleshooting, repair and parts information can be found in the rear section of this manual.

TIMING

FIRING ORDER

The *firing order* of the cylinders is 1-3-4-2, and the battery type distributor rotates at one-half engine speed, as is the case with conventional 'in line' engines. The intervals between the firing of the cylinders is 180°. No. 1 cylinder is the one nearest to the flywheel in the left bank of cylinders, when viewed from the flywheel end of the engine. No. 3 cylinder is the other cylinder in this bank. No. 2 cylinder is the one nearest to the flywheel in the right bank of cylinders and No. 4 is the other cylinder in this bank. The

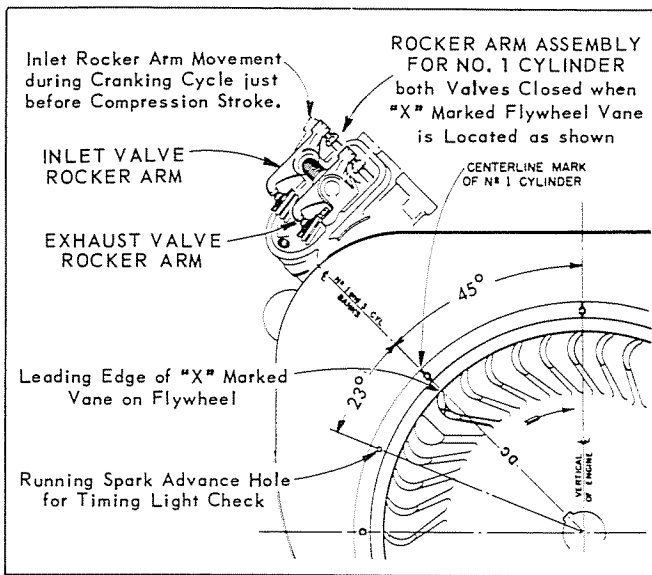

Fig. 6

cylinders are numbered from 1 to 4 on the cylinder head covers.

TIMING MARKS (Refer to Fig. 6)

Remove screen over flywheel air intake opening by taking out the screws holding screen in place. This will expose the timing marks on flywheel shroud, also the *vane* on flywheel marked by an 'X' and the letters 'DC'.

NOTE: On engines equipped with a rotating screen attached to the flywheel, the *leading edge* of the 'X' marked vane is identified by an 'I' stamped on the outer rim of the screen, thereby not requiring removal of the rotating screen when timing the engine.

TIMING INSTRUCTIONS: The No. 1 piston must be on top dead center of the compression stroke before distributor can be mounted. With reference to Fig. 6, this can be accomplished as follows:

1. Remove rocker arm cover from No. 1 cylinder bank.
2. Turn engine over with hand crank until the *inlet valve* opens and then *closes*.
3. Continue turning the engine over until the *leading edge* of the 'X' marked vane on the flywheel is in line with the *centerline mark* of the No. 1 and 3 cylinder-banks.
4. **DISTRIBUTOR TIMING:** With the No. 1 piston now on *TDC* of the compression stroke, refer to Fig. 7 for the revised *Delco-Remy* distributor or Fig. 7A for *Prestolite*, and mount distributor as follows:
 - a. Before mounting distributor to housing, take off distributor cap, remove rotor and dust cover.
 - b. Hold distributor with face up and *terminal wire* or *terminal stud*, away and in a 12 o'clock position as shown. Mount rotor on shaft and turn until the *rotor contact* points in an approximate 2 o'clock position as illustrated in Fig. 7, or 1 o'clock position as in Fig. 7A.
 - c. Assemble distributor to housing, properly meshing the gears while retaining the terminal wire

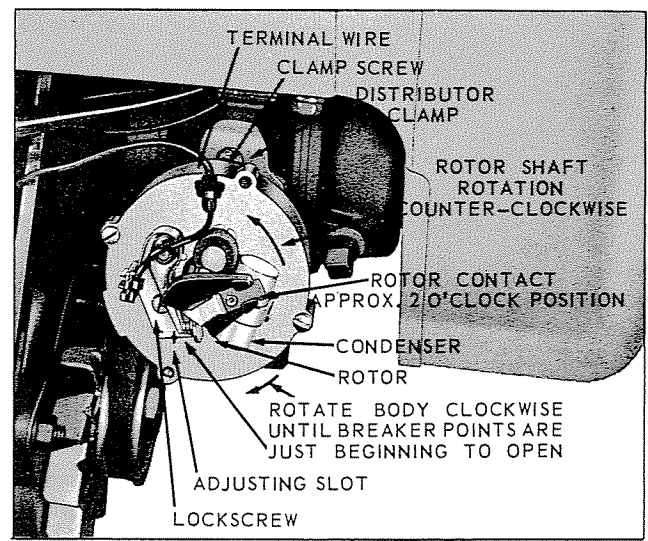

Fig. 7, DELCO-REMY DISTRIBUTOR

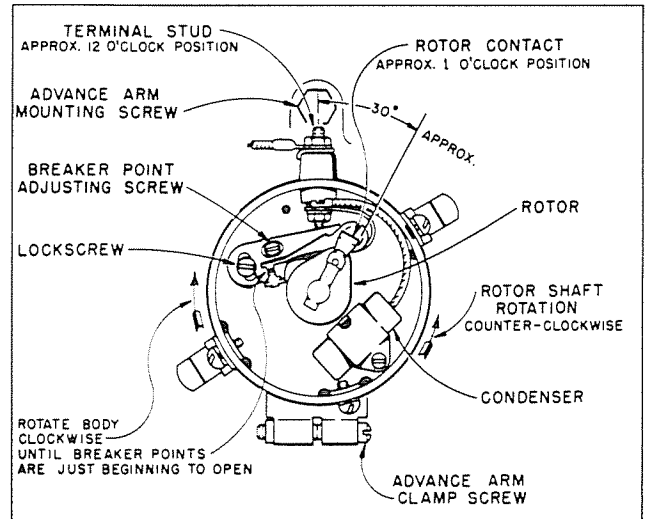

Fig. 7A, PRESTOLITE DISTRIBUTOR

or stud in an approximate 12 o'clock position.

- d. Mount *distributor clamp* to drive housing, Fig. 7, but do not tighten screw. If applicable, as per Fig. 7A, tighten *advance arm mounting screw* to the drive housing.
- e. Adjust breaker point gap to *0.020 inch maximum* opening, see 'Distributor Maintenance'.
- f. With the *clamp screw loose*, turn distributor body slightly in a counter-clockwise rotation so that breaker points are firmly closed. Then turn distributor body in a *clockwise* rotation until *breaker points* are just *beginning to open*. At this point a slight resistance can be felt as the breaker point cam strikes the breaker arm.
- g. Tighten *clamp screw*. The No. 1 cylinder is now ready to fire in the retarded position.

The breaker point gap of 0.020 of an inch should be checked and adjusted per paragraph (e), before distributor body is set and locked in place, as per paragraphs (f) and (g), because any change in gap opening will affect the ignition advance. Mount dust cover and distributor cap.

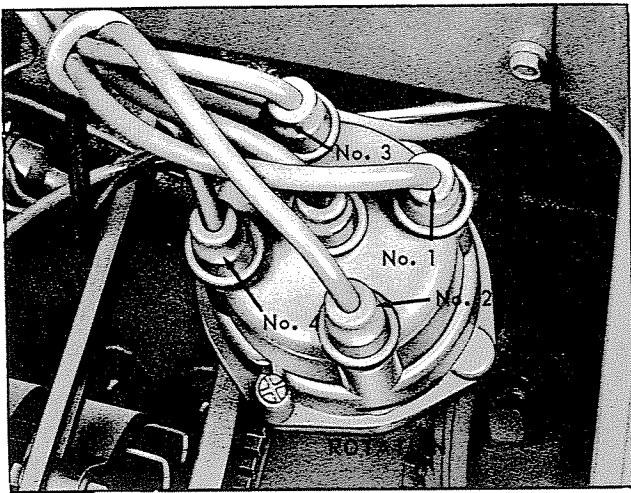

Fig. 7B, DELCO-REMY DISTRIBUTOR MOUNTING

If care is exercised in the preceding instructions, the spark timing should be accurate enough for satisfactory starting, however, *checking spark advance with a neon lamp, as described in 'Neon Lamp Timing' is necessary.*

The *No. 1 terminal tower* for the *Delco-Remy* distributor is located in an approximate 2 o'clock position on the distributor cap, as illustrated in *Fig. 7B*, and in an approximate 1 o'clock location for the *Prestolite* distributor. The terminal sequence is *1-3-4-2* in a counter-clockwise direction. Mount ignition cables to spark plugs of like numbers, with the center terminal tower connected to the ignition coil. See *Wiring Diagram, Fig. 9*. The cylinder shroud covers are marked for spark plug identification.

NEON LAMP TIMING (Fig. 8)

The engine should be timed to the 23° advanced position at not less than 2000 R.P.M. Check timing with a neon lamp as shown in *Fig. 8*; insert a small screw driver into the *No. 1 terminal tower* on the distributor cap, making contact with the spark plug wire terminal.

Connect the red terminal clip, from a conventional type timing lamp, to the metal portion of the screw driver. One of the other two timing lamp wires is connected to the battery, and the other to ground.

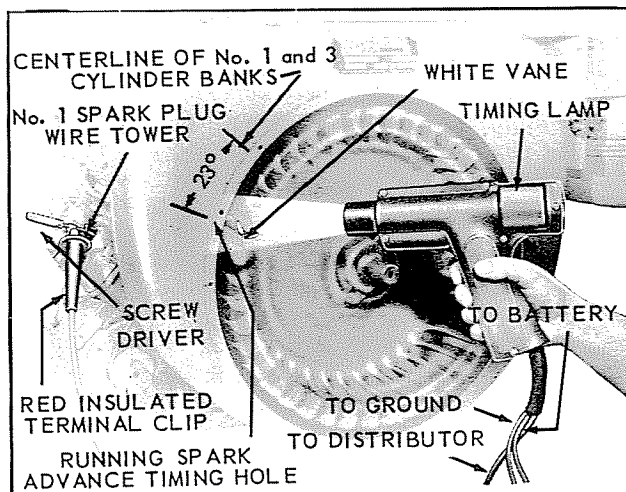

Fig. 8

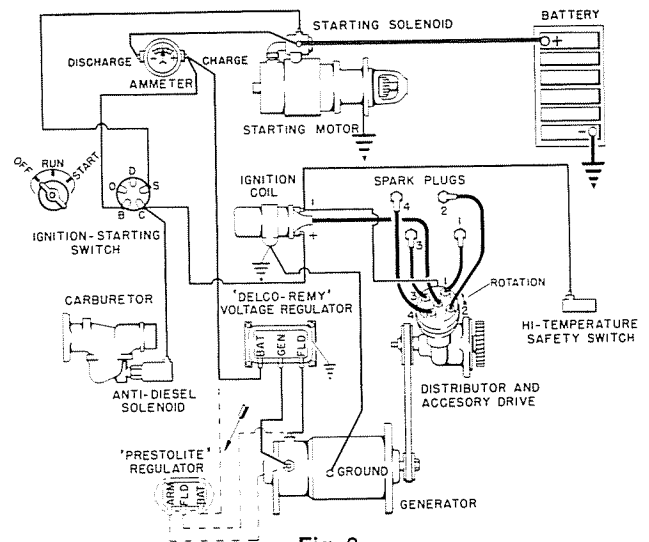

Fig. 9
DISTRIBUTOR IGNITION — WIRING DIAGRAM
WITH GENERATOR

(DISTRIBUTOR IGNITION — WIRING DIAGRAM WITH ALTERNATOR
See Page 34)

Chalk or paint the end of the 'X' marked vane on the flywheel, white. Then with the engine operating at *2000 R.P.M.* or over, allow the flash from the neon lamp to illuminate the whitened vane. At the time of the flash, the leading edge of the vane should line up with the *running spark advance timing hole* on the flywheel shroud, *see Fig. 8*. If it does not, the distributor *clamp screw* should be loosened and the distributor body turned slightly clockwise or counter-clockwise, as required, until the *white flywheel vane* matches up with the *advance timing hole*. Be sure *clamp screw* is then carefully tightened.

If the engine is running below *2000 R.P.M.* when timing, the automatic advance in the distributor will not be in the "full advance position" and thus the timing would not be accurate.

DISTRIBUTOR MAINTENANCE

The normal breaker point gap is *0.020 inch* at full separation and can be adjusted in the following manner, with reference to *Figs. 7 or 7A*: Turn engine over by means of the starting crank until the distributor breaker arm *rubbing block* is on a high point of the *cam*. Loosen the stationary contact *lockscrew* very slightly and insert a feeler gauge between the points. By means of a screw driver inserted into the *adjusting slot* of the *Delco-Remy* distributor or by the *adjusting screw* of the *Prestolite* distributor, open or close points as required until a slight drag is felt when sliding feeler gauge between the points. Tighten *lockscrew* and recheck gap.

Every 50 hours of operation, the oiler on the side of the *Prestolite* distributor base should have 3 to 5 drops of medium engine oil added. The old style *Delco-Remy* distributor has a built-in oil reservoir. Every 200 hours of operation, remove oil plug in base and refill with No. 20W oil. Seal plug in reassembly. The *new style Delco-Remy* distributor does not have an external oil plug, since it is self-lubricated by oil in the accessory drive housing.

Every 100 hours, apply 3 to 5 drops of light engine oil (10W), to the felt in the top of the cam sleeve, and 1 or 2 drops to the breaker arm pivot.

Every 200 hours, add a small amount of high melting point grease to breaker arm rubbing block, or oil the cam wick.

Avoid excessive lubrication. Oil that may get on the contact points will cause them to burn.

GENERATOR

A 12 volt, 17 amp. generator was furnished as standard equipment, on older model engines, unless otherwise specified. The generator is manufactured by either the *Delco-Remy* Company or *Prestolite* Company.

Every 50 hours of operation, add 3 to 5 drops of medium engine oil into the oil cap at both ends of the generator.

ELECTRICAL WIRING CIRCUITS

Beginning with engine serial No. 3979807, the standard wiring circuits for all electrical equipment is for *negative ground polarity*, instead of the previously furnished positive ground.

The wiring diagram, Fig. 9, illustrates a negative ground circuit. To wire equipment that has a positive ground polarity; reverse terminal connections at the ammeter, coil and battery. **Be sure polarity of generator and regulator is known when re-wiring.**

Do not use positive ground generator and regulator in a negative ground circuit, or vice versa. Polarity does not affect starting motor, coil and distributor.

MAGNETO TIMING

For engines furnished with magneto ignition in place of distributor ignition, timing is accomplished in the following manner:

1. Expose timing marks on flywheel and shroud. Refer to 'Timing Marks' paragraphs on Page 13.
2. Position No. 1 piston on compression stroke, as per 'Timing Instructions' paragraphs on Page 13.
3. With No. 1 piston on compression stroke turn engine over past top dead center, until the *leading edge* of the 'X' marked vane on the flywheel is in line with the *vertical centerline mark* on the shroud, as shown in Fig. 10. Leave flywheel in this position (flywheel keyway will be on top).
4. Remove *inspection hole* plug, located in gear cover at magneto mounting flange.
5. Assuming the magneto is removed from the engine; set magneto for spark discharge to the No. 1 terminal. This is accomplished by use of a short stiff length of wire placed into the No. 1 terminal socket and bent to within 1/8 inch of the magneto frame. Then turn the magneto gear in a clockwise rotation, tripping the impulse coupling, until a spark is observed between the wire and frame. Retain gear in this position.
6. Place gasket on flange and mount magneto to engine, meshing the gears so that when magneto is assembled, the gear tooth marked with an 'X' will be visible through the *lower half* of the *inspection*

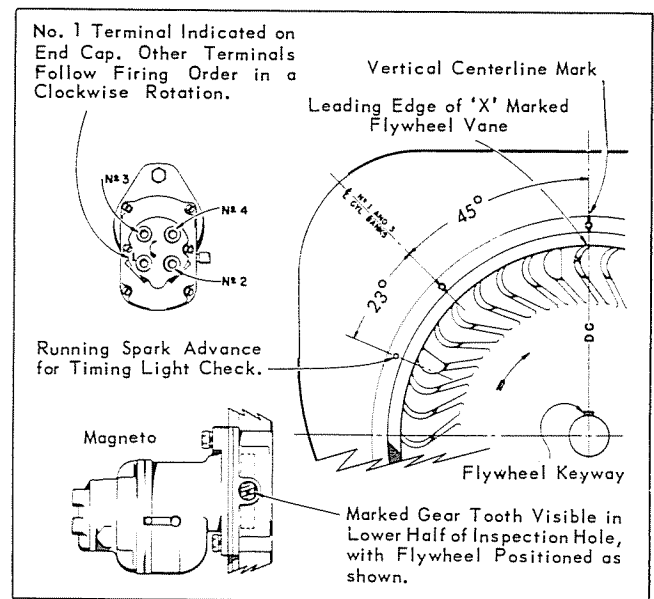

Fig. 10
MAGNETO TIMING DIAGRAM

hole in gear cover. See *Magneto Timing Diagram, Fig. 10*. Securely tighten nut and capscrew for mounting magneto.

The No. 1 terminal is identified on the magneto cap. The terminals follow the proper firing order of 1-3-4-2 in a clockwise direction viewing the cap end. The leads from the magneto should be connected to spark plugs of corresponding numbers, see *Firing Order* paragraph page 12 and *Wiring Diagram, Fig. 11*.

When magneto is properly timed the impulse coupling will snap when the 'DC' - 'X' marked vane of the flywheel lines up with the *mark* on flywheel, which indicates the *centerline* of the No. 1 and 3 cylinders. This can be checked by turning crankshaft over slowly by hand. The impulse will also snap every 180° of flywheel rotation thereafter.

The running spark advance is 23°. To check timing with a *neon light*, the advance is indicated by a hole on the flywheel shroud, 23° before *centerline* of the No. 1 and 3 cylinders. See Fig. 10.

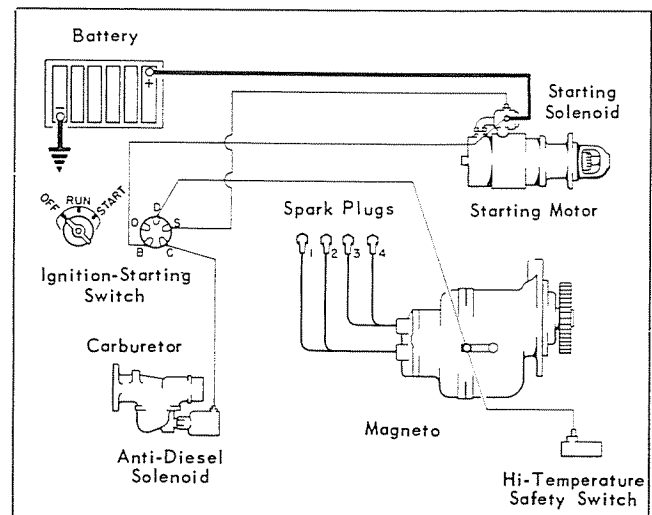

Fig. 11
MAGNETO IGNITION - WIRING DIAGRAM

The magneto is driven at crankshaft speed in clockwise direction when viewing gear end of magneto. The magneto *distributor rotor* turns at *half engine speed*.

Magneto *breaker point gap* is *0.015 inch* at full separation. If the ignition spark becomes weak after continued operation, the breaker points may have to be readjusted or replaced. Refer to Magneto Service Instructions in rear of manual for service and adjustment of breaker points.

IGNITION SPARK (Fig. 12)

If difficulty is experienced in starting the engine or if engine misses firing, the strength of the ignition spark may be tested as follows: *Disconnect* the cables from all towers on the distributor cap, except the center coil tower. Insert a stiff piece of wire or metal rod into one of the sockets. Hold the terminal for this tower 1/8 inch from the wire or rod, as shown in *Fig. 12*. Turn engine over slowly, two complete revolutions with the hand crank and watch for a spark to discharge during the cranking cycle.

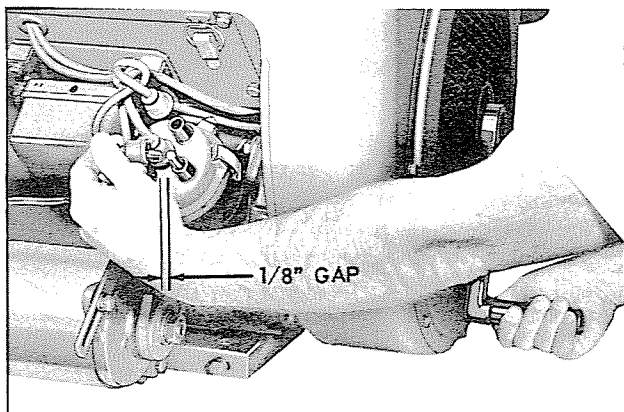

Fig. 12

Repeat this check with each of the other ignition cables. A good spark at each of the towers will eliminate the ignition coil and distributor as the source of trouble. If there is a weak spark, or none at all, check breaker point opening for *0.020 inch* gap. It may be necessary to install a new condenser, or the ignition coil may be faulty.

SPARK PLUGS (Fig. 13)

The spark plugs should be removed periodically, cleaned and re-gapped. Approximately every 350 hours of operation, replace spark plugs with new plugs of correct heat range, like Champion 14 mm, No. N-12Y or equal.

The width of the gap between the points of the two electrodes must be very carefully and precisely set, because incorrect settings will have an adverse affect on engine operation. Check spark plug gap with a wire type gauge and regap as shown in *Fig. 13*.

Spark plug gap – 0.030 of an inch.

Use a new gasket when mounting either old or new plugs and thoroughly clean threads in cylinder head before installation. Tighten spark plugs to *22 foot pounds torque*. If torque wrench is not available,

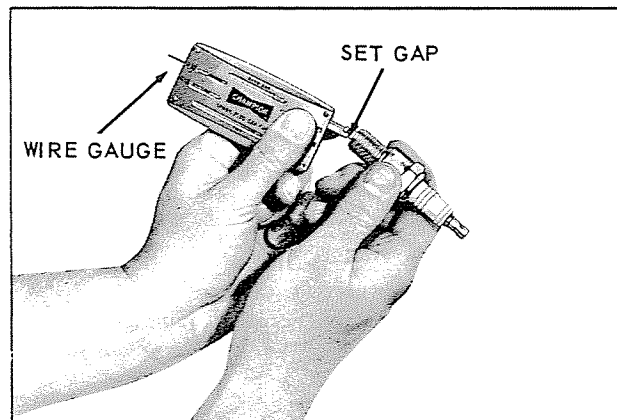

Fig. 13

tighten plug until it begins to seat on the gasket, then turn 1/2 to 3/4 of a turn more.

RESTORING COMPRESSION

On a new engine or on one which has been out of operation for some time, the oil may have drained off the cylinder so that compression will be weak. This may cause difficulty in starting. To remedy this condition, remove the spark plugs and squirt about a fluid ounce of crankcase oil through the spark plug hole into each cylinder.

Turn the engine over several times with the starting crank to distribute the oil over the cylinder walls. Then reassemble spark plugs and compression should be satisfactory.

VALVE TAPPET ADJUSTMENT (Fig. 14)

The clearance between the valve and rocker arm, with the tappet in its lowest position (valve completely closed) and the engine *cold*:

Inlet – 0.008 inch
Exhaust – 0.014 inch

The rocker arms can be identified as follows: When facing the side of the engine, the *exhaust rocker arm*

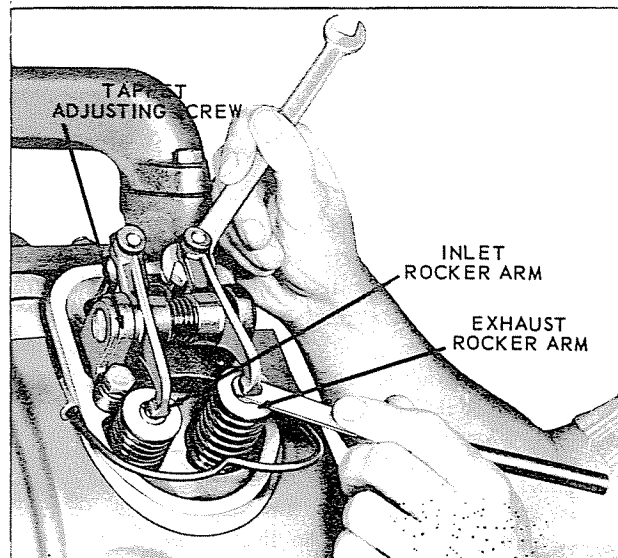

Fig. 14

is to the right in the cylinder head and the *inlet rocker arm* to the left.

Measure the clearance between the top of the valve and the nose of the rocker arm with a feeler gauge, as shown in *Fig. 14*. By means of a $\frac{1}{2}$ inch tappet wrench, turn the *tappet adjusting screw* clockwise to decrease valve clearance and counter-clockwise to increase the clearance.

The sequence in which the tappets are adjusted is determined by the 1-3-4-2 firing order. Start by adjusting No. 1 inlet valve clearance first, then by just a short turn of the crank, No. 3 inlet can be adjusted. Return to No. 1 cylinder and adjust the exhaust clearance, then adjust the No. 3 exhaust.

The same procedure applies to the No. 2 and No. 4 bank of cylinders, starting with No. 4 inlet valve. Mark each rocker arm with chalk as adjustment is completed, to prevent repetition. With spark plugs removed, turning crankshaft is made easier.

ROCKER ARM COVERS (Fig. 15)

When reassembling rocker arm covers, after timing or valve tappet adjustment, *carefully* replace the cover gaskets to prevent oil leaks.

If oil does appear around the rocker arm covers, reassemble in the following manner:

1. Check gasket face surface of rocker arm cover, at the rounded end, for paint accumulation, *see Fig. 15*. Scrape off any paint that forms a hump. Smooth scraped area with emery cloth or steel wool.
2. Clean gasket faces on the cylinder head and rocker arm covers.
3. Spread a thin coat of perma-tex into the rocker arm cover, to hold gasket in place. This will prevent gasket slippage or deformation when mounting cover to cylinder head.
4. Use new gaskets. Old gaskets harden, take a "set" and will very likely leak.

GOVERNOR

OPERATION

The centrifugal flyball governor rotates on a stationary pin pressed into the upper part of the timing gear cover. The governor is driven off the camshaft gear and turns $\frac{1}{8}$ faster than crankshaft speed.

Flyweights are hinged to lugs on the drive gear. Hardened pins on the flyweights bear against a flanged sliding sleeve, moving it back and forth as the flyweights move in or out. The motion of the sleeve is transmitted through a ball thrust bearing to the governor lever, which in turn is connected to the carburetor throttle lever. A spring connected to the governor lever tends to hold the governor flyweights to their *inner* position, also to hold the carburetor throttle open. As the engine speed increases, centrifugal force in the flyweights acts against the spring and closes the throttle to a point where the engine speed will be maintained practically constant under varying load conditions. This speed can be varied to

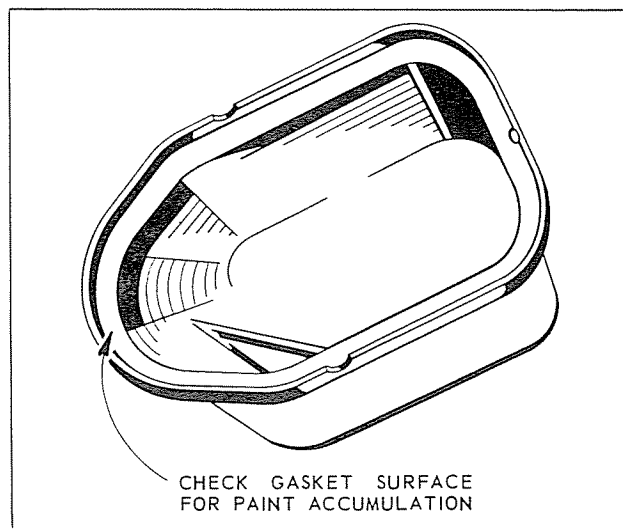

Fig. 15

suit conditions by adjusting the governor spring tension.

GOVERNOR ADJUSTMENT (Fig. 16, Fig. 17)

The governor rod connection to the carburetor must be very carefully adjusted for length, otherwise the governor will not function properly and cause the engine to surge badly. With the engine at rest, the governor spring will keep the flyweights *in*, and the control rod must be of such length as to hold the carburetor throttle wide open at that point.

With the *control rod* disconnected from the *governor lever*, as illustrated in *Fig. 16*, push the rod toward the carburetor as far as it will go. This will put the *carburetor throttle lever* in a wide open position. The governor lever should then be moved as far as possible in the same direction. Holding both parts in the above position, the rod should be screwed in or out of the *swivel block* on the carburetor, until the bent end of the rod will register with *hole* in lever, then screw rod in one more turn. The extra turn will shorten

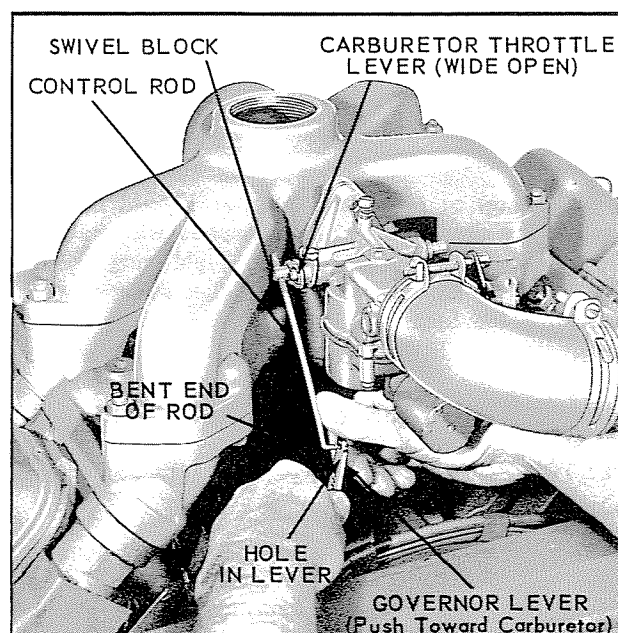

Fig. 16

FULL LOAD R.P.M.	NO LOAD R.P.M.	HOLE NO.	GOVERNOR LEVER
1500	1685	3	
1600	1825	4	
1700	1855	4	
1800	2000	5	
1900	2055	5	
2000	2200	6	
2100	2230	6	
2200	2375	7	
2300	2440	7	
2400	2545	8	
2500	2695	9	
2600	2745	9	
2700	2810	9	
2800	2935	10	
2900	3065	11	
3000	3175	12	

Fig. 17

the linkage slightly and will enable the carburetor throttle lever to bounce back from the stop pin rather than jam against the pin, when a load is suddenly applied to an idling engine. This will eliminate excessive wear on the threads in the carburetor throttle swivel block.

The governor lever, *Fig. 17*, is furnished with 12 holes for attaching the governor spring. It is very important that the spring is hooked into the proper hole to suit the speed at which the engine is to be operated. The Governor Lever Chart shows the full load and no load speeds of the engine and the hole corresponding thereto, for either a fixed speed, a variable speed or two speed (over-center idle control) governor. Note that the *full load* speed is less than the *no load* speed and this must be taken into consideration when readjusting the governor. As an example; if the engine is to be operated at 2000 revolutions per minute under load, the spring should be hooked into the 6th hole in the governor lever and the spring tension adjusted, by means of the adjusting screw, to run 2200 R.P.M. under no load. The speed at full load will then be approximately 2000 revolutions per minute.

A tachometer or revolution counter should be used against the crankshaft to check speed while adjusting the governor spring tension. Tightening the adjusting screw locknut will give higher speeds, while loosening the locknut will lower the spring tension and reduce the R.P.M.

CLUTCH AND REDUCTION UNITS

CLUTCH POWER TAKE-OFF (Fig. 18)

The clutch available on this engine is of the dry disc type. No oil should be put into the clutch housing, but grease gun fittings are provided for periodic bearing lubrication. The *housing bearing* should be greased every fifty hours of operation and the clutch *throwout*

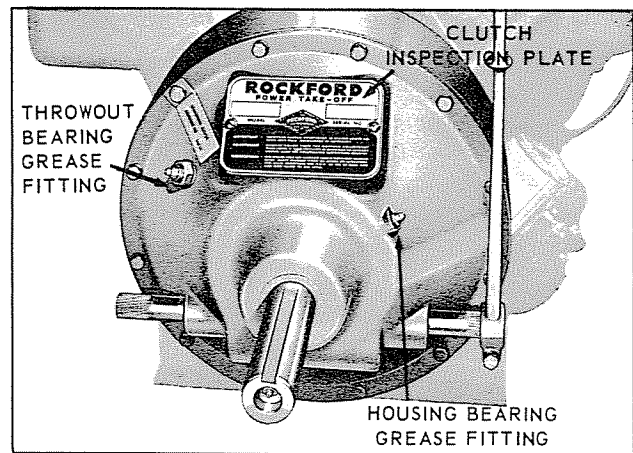

Fig. 18

bearing greased every day before starting. Use Mobil Gargoyle grease BRB No. 3, Sinclair AF-1 grease, or equal.

Rockford PTA-4856 units have a sealed pilot bearing and require no external lubrication. *Obsolete* PTA-4819 units have a pilot bearing grease fitting at the end of the drive shaft and are lubricated same as the housing bearing.

CLUTCH ADJUSTMENT (Fig. 19 or Fig. 20)

If the clutch begins to slip it should be readjusted, otherwise it will become overheated and damaged. First, remove the clutch inspection plate and release the *clutch operating lever*. For the *Rockford clutch*, turn engine over by means of the hand crank until the *clutch adjustment lock* is visible thru the inspection opening in the clutch housing, see *Fig. 19*. The clutch must be held stationary, either by means of a drift punch wedged in place as shown, or by some convenient method of keeping the take-off shaft from turning. Loosen screw holding the *adjustment lock* in place. Insert a screw driver in one of the notches and turn the *adjusting ring* in a *counter-clockwise* direction, one notch at a time, until a very firm pressure is required to engage the clutch with the *operating lever*. Tighten adjusting lock screw and mount inspection cover.

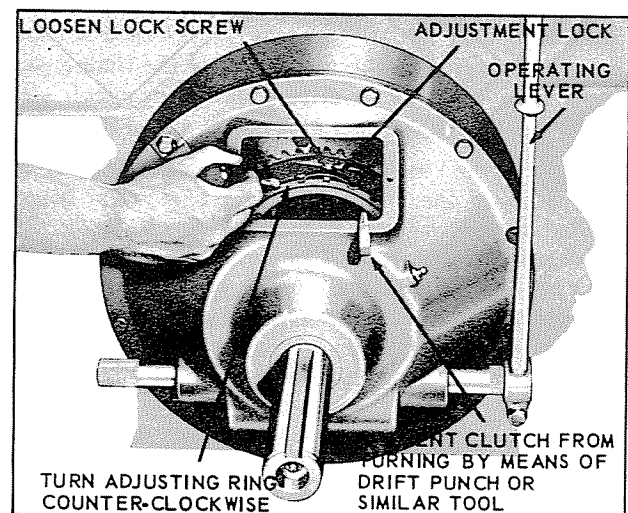

Fig. 19

ROCKFORD CLUTCH ADJUSTMENT

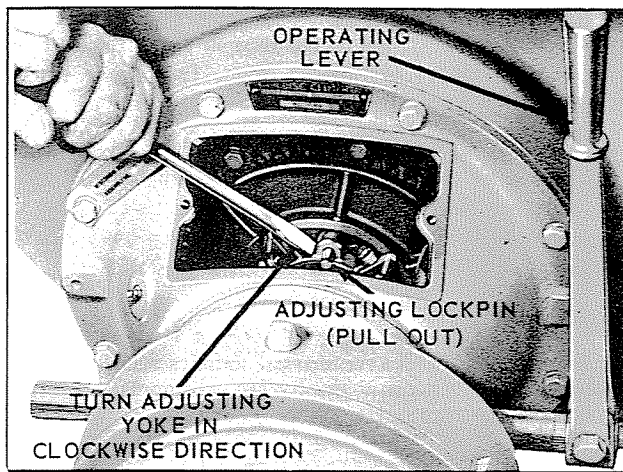

Fig. 20
TWIN DISC CLUTCH ADJUSTMENT

For the *Twin Disc* clutch, pull *adjusting lockpin* out and insert a piece of 1/16" diameter wire into the hole on the side of the lockpin to keep pin in outer position. See Fig. 20. Turn the *adjusting yoke* in a clockwise direction as shown, or wedge a screw driver into the adjusting yoke and against the side of the inspection hole opening to keep yoke from turning, and then turn the take-off shaft counter-clockwise. Tighten yoke enough so that the *operating lever* requires a distinct pressure to engage. Remove wire from lockpin and turn adjusting yoke slightly, to allow lockpin to snap into hole in floating plate.

A new clutch requires several adjustments until friction surfaces are worn in. *Do not let a new clutch slip*, this may ruin the friction surfaces.

CLUTCH REDUCTION UNIT (Fig. 21)

The clutch in the clutch reduction units is of the dry disc type, the same as is used in the power take-off units. Therefore, *no oil should be put in the clutch housing*.

The *throwout bearing* should be lubricated once a day before starting. Add grease to fitting thru opening on side of housing, as illustrated in Fig. 21, using the

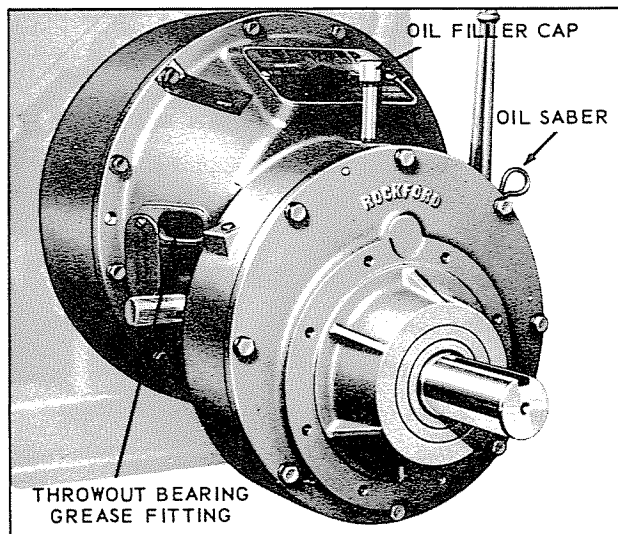

Fig. 21
ROCKFORD CLUTCH REDUCTION UNIT

same type grease as used in the clutch power take-off units. *Twin Disc* units have an external grease fitting for the throwout bearing.

The shifter shaft should be lubricated periodically, if external oil fittings are provided for this purpose.

The reduction unit is operated in oil and the gear case oil level must be maintained to the oil *saber* gauge mark or *plug* opening, see Fig. 21. In *Twin Disc* units, high grade transmission oil S.A.E. No. 90 to No. 110 Viscosity must be used. For *Rockford* units, use No. 30 S.A.E. crankcase oil. Change oil every 2000 hours of service, while unit is warm.

If clutch slips, heats, or operating lever jumps out, the clutch must be adjusted. Release clutch operating lever and remove hand hole plate. The *clutch* in the clutch reduction units is the same as is used in the clutch power take-off units. Refer to "Clutch Adjustment" paragraph for adjustment of the clutch in the *Twin Disc* and *Rockford* clutch reduction units. A new clutch generally requires several adjustments until the friction surfaces are worn in.

HIGH TEMPERATURE SAFETY SWITCH (Fig. 22)

The high temperature safety switch is mounted on the cylinder head near the *No. 4* spark plug. This safety switch will automatically stop the engine when head temperatures become critically high.

If an extreme cylinder head temperature causes the switch to automatically short out the ignition system and stop the engine, a waiting period of about 5 *minutes* will be required before the switch has cooled off sufficiently to allow the engine to be re-started. An overheated engine will score the cylinder walls, burn out connecting rod and crankshaft bearings, also warp pistons and valves. The cause of the overheating condition will have to be remedied before the engine is re-started. See *Engine Overheats* paragraph in *Troubles, Causes and Remedies* section.

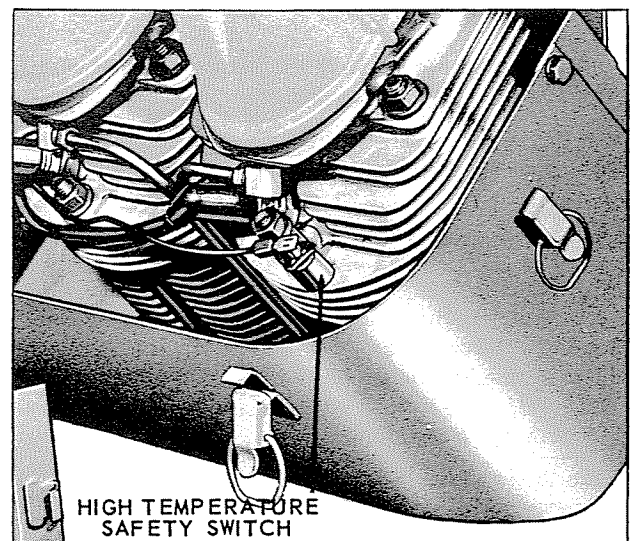

Fig. 22

TROUBLES – CAUSES AND REMEDIES

Three prime requisites are essential to starting and maintaining satisfactory operation of gasoline engines. They are:

1. *A proper fuel mixture* in the cylinder.
2. *Good compression* in the cylinder.
3. *Good spark, properly timed*, to ignite the mixture.

If all three of these conditions do not exist, the engine cannot be started. There are other factors which contribute to hard starting; such as too heavy a load for the engine to turn over at a low starting speed, a long exhaust pipe with high back pressure, etc. These conditions may affect starting, but do not necessarily mean the engine is improperly adjusted.

As a guide to locating any difficulties which might arise, the following causes are listed under the three headings: *Fuel Mixture, Compression, and Ignition*. In each case, the causes of trouble are given in the order in which they are most apt to occur. If a remedy is apparent, no remedy is suggested.

STARTING DIFFICULTIES

FUEL MIXTURE

No fuel in tank, shut-off closed or cap vent plugged.

Fuel pump diaphragm worn out or punctured.

Carburetor not choked sufficiently, especially if engine is cold. *See 'Starting Procedure'*.

Water, dirt, or gum in gasoline interfering with free flow of fuel to carburetor.

Anti-diesel solenoid valve, at carburetor, inoperative.

Check operation of valve: A solenoid *'click'* should be heard when ignition switch is turned to start position. *If not;*

Check for disconnected, loose or broken wire.

Remove solenoid from carburetor – clean plunger and seat with solvent. Check plunger for spring tension.

Replace solenoid valve if the above does not rectify the problem.

Poor grade or stale gasoline that will not vaporize sufficiently to form the proper fuel mixture.

Carburetor flooded, due to excessive choking. *See 'Starting Procedure'*.

Dirt or gum holding float needle valve in carburetor open. This condition will be indicated if fuel continues to drip from carburetor with engine standing idle. Often tapping the float chamber of the carburetor very lightly will remedy this trouble. Do not strike carburetor with any metal tool.

If due to flooding, too much fuel entered the cylinder in attempting to start the engine, the mixture will most likely be too rich to burn. In that case, starting may be accomplished by continued cranking with the carburetor choke open.

To test for clogged fuel line, loosen fuel line nut at carburetor slightly. If line is open, fuel should drip out at loosened nut.

If the starter is *'dead'* or is unable to turn the engine over, check battery and cable connections at the battery, starting motor, and starting switch; also check for broken or frayed cables. Test starting switch and starting motor and replace or repair if necessary.

COMPRESSION

Compression check with a commercial compression test gauge can show whether or not an engine has faulty compression. TTP does not consider it practical to publish a PSI compression figure because of the variables involved: engine condition, method of testing, and RPM of test. Our recommendation is that whatever gauge test is performed, a 10% variance between cylinders would indicate leaking rings, leaking valves or any of the following:

Cylinder dry due to engine having been out of use for some time. *See 'Restoring Compression'*.

Loose spark plugs or broken spark plug. In this case a hissing noise will be heard when cranking engine, due to escaping gas mixture on compression stroke.

Damaged cylinder head gasket or loose cylinder head. This will likewise cause hissing noise on compression stroke.

Valve stuck open due to carbon or gum on valve stem.

Valves adjusted with insufficient clearance under valve stems. *See 'Valve Tappet Adjustment'*.

Piston rings stuck in piston due to carbon accumulation.

Scored cylinders. This will require reboring of the cylinders and fitting with oversize pistons and rings, or replacement of complete cylinder barrels.

IGNITION

No spark may be attributed to the following:

Ignition cable disconnected from coil, distributor, or spark plugs. Cables wet.

Broken ignition cables, causing short circuits.

Spark plug insulators broken. Plugs wet or dirty.

Spark plug point gap wrong. *See 'Spark Plugs'*.

Condensation on spark plug electrodes.

Breaker points pitted or fused. Breaker arm sticking.

Distributor condenser leaking or grounded.

Spark timing wrong. *See 'Timing'*.

ENGINE MISSES

Spark plug gap incorrect. *See 'Spark Plugs'*.

Worn and leaking ignition cables.

Weak spark or no spark in one of the cylinders.

Loose connection at ignition cable.

Distributor breaker points pitted, worn or incorrect gap. *See 'Distributor Timing'*.

Water in gasoline.

Poor compression. *See 'Compression'*.

Sticky valves.

ENGINE SURGES OR GALLOPS

Carburetor flooded.

Governor spring hooked into wrong hole in lever.
Governor rod incorrectly adjusted. *See 'Governor Adjustment'*.

ENGINE STOPS

Fuel tank empty.

Water, dirt or gum in gasoline.

Gasoline vaporized in fuel lines, due to excessive heat around engine (Vapor Lock). *See 'Stopping Engine'*.

Vapor lock in fuel lines or carburetor due to using winter gas (too volatile) in hot weather.

Air vent hole in fuel tank cap plugged. Engine scored or stuck due to lack of oil.

Ignition troubles. *See 'Ignition'*.

Wire from anti-diesel solenoid to starting switch disconnected or damaged.

ENGINE OVERHEATS

Crankcase oil supply low. Replenish immediately.

Ignition spark timed wrong. *See 'Neon Lamp Timing'*.

Low grade of gasoline.

Engine overloaded.

Restricted cooling air circulation.

Part of air shroud removed from engine.

Dirt between cooling fins on cylinder or head.

Engine operated in confined space where cooling air is continually recirculated, consequently becoming too hot.

Carbon in engine.

Dirty or incorrect grade of crankcase oil.

Restricted exhaust.

Engine operated while detonating due to low octane gasoline, or heavy load at low speed.

ENGINE KNOCKS

Poor grade of gasoline or of low octane rating. *See 'Fuel'*.

Engine operating under heavy load at low speed.

Carbon or lead deposits in cylinder head.

Spark advanced too far. *See 'Neon Lamp Timing'*.

Loose or burnt out connecting rod bearing.

Engine overheated due to causes under previous heading.

Worn or loose piston pin.

ENGINE BACKFIRES THROUGH CARBURETOR

Water or dirt in gasoline.

Engine cold.

Poor grade of gasoline.

Sticky inlet valves.

Overheated valves.

Spark plugs too hot. *See 'Spark Plugs'*.

Hot carbon particles in engine.

LOW or NO OIL PRESSURE

Oil pressure gauge defective.

Oil line to gauge clogged up.

Crankcase oil supply low.

Faulty oil pump.

Gears worn or broken.

Cover worn.

Loose cover or body.

Gasket damaged.

Faulty relief valve.

Clogged or leaky oil line connections.

Strainer screen clogged up.

Oil too thin due to dilution or too light of grade used.

Worn rod bearings.

HIGH OIL PRESSURE

Oil pressure gauge defective.

Oil too heavy.

Faulty relief valve.

Clogged pressure line.

INSTRUCTIONS FOR PROTECTING ENGINES FOR WINTER OR SHORT STORAGE PERIODS

To protect the cylinders, pistons, rings and valves and keep them from rusting and sticking, a half and half mixture of kerosene and good engine oil, (the same kind of oil as used in the crankcase of the engine), should be injected into the pipe tap opening on the intake manifold while the engine is warm and running at moderate speed. About a quarter of a pint is necessary, or enough so that a heavy bluish smoke will appear at the exhaust. The ignition switch should then be shut off and the engine stopped. This fogging operation will leave a coating of oil on the above mentioned parts, protecting them from the atmosphere.

Drain crankcase oil while the engine is warm, as the oil will flow more freely than when cold.

Drain fuel lines, carburetor, fuel pump and tank of all gasoline, to prevent lead and gum sediment from in-

terfering with future operation. Gasoline fumes from gradual evaporation is a dangerous *fire hazard*.

The air cleaner should be thoroughly cleaned of all oil and accumulated dust, and the sediment removed from the oil cup at the bottom of the cleaner.

Tape or otherwise seal off the air cleaner or carburetor intake, as well as the exhaust and breather openings, for the duration of the storage period.

The outside of the engine, including the cooling fins on the cylinders and heads, should be thoroughly cleaned of all dirt and other deposits.

All exposed unpainted metal parts should be coated with grease or heavy oil.

Before starting the engine after the storage period, remove crankcase drain plug so that any condensation which may have collected may be drained before new crankcase oil is added. It is highly recommend-

ed that the crankcase bottom cover be removed and scrubbed of all sediment which may have collected there. When reassembling the bottom cover, a new gasket should be used.

Fill crankcase with the correct grade of oil to the full mark on the saber. Do not use any oil heavier than SAE No. 30. Also be sure to put oil to the proper level in the air cleaner. (Refer to Lubrication and Air Cleaner.)

It is advisable to use new spark plugs at the beginning of the operating interval, especially if the engine has given considerable service.

Refuel engine and follow the starting instructions as shown on preceding pages of this manual.

It is suggested that machines be stored inside a building. If this is not possible, protect the engine from the weather by a proper covering.

DISASSEMBLY AND REASSEMBLY OF ENGINE

Engine repairs should be made only by a mechanic who has had experience in such work. When disassembling the engine, it is advisable to have several boxes available so that parts belonging to certain groups can be kept together. Capscrews of various lengths are used in the engine, therefore great care must be exercised in reassembly so the right screw will be used in the proper place.

Tighten the capscrews and nuts of the manifolds, cylinder heads, gear cover, oil pan, connecting rods, cylinder barrels, main bearing plate and the spark plugs to the specified torque readings indicated in the paragraphs of reassembly, relative to these parts.

While the engine is partly or fully dismantled, all of the parts should be thoroughly cleaned. Use all new gaskets and 'O' rings in reassembly, and lubricate all bearing surfaces.

The following procedure is for complete disassembly of an engine. As disassembly progresses, the order may be altered somewhat, as will be self-evident to the mechanic. Reassembly of the engine should be made in the reverse order.

TESTING REBUILT ENGINE

An engine that has been rebuilt with new connecting rod shell bearings and having cylinders rebored or replaced, and fitted with new pistons, rings and valves, should go through a thorough "run-in" period before any load is applied to it.

The engine should be started and allowed to run for about one-half hour at about 1200 to 1400 R.P.M. without load. The R.P.M. should then be increased to engine operating speed, still without load, for an additional three and one-half to four hours.

The proper "running-in" of the engine will help to establish polished bearing surfaces and proper clearances between the various moving parts and thus add years of trouble free service to the life of your engine.

ACCESSORIES

Remove *clutch* or *clutch reduction* unit if engine is equipped with either of these accessories.

AIR CLEANER can be removed as a complete unit when flywheel shroud is removed. Disconnect tubing and elbow connection from carburetor to air cleaner.

CONTROL PANEL can remain on flywheel shroud, but disconnect: ignition wires from anti-diesel solenoid, starting solenoid, choke wire at carburetor, hose at oil pressure gauge, variable speed control, ignition wires at coil and voltage regulator (battery terminal).

OIL FILTER is removed by tapping side of cartridge with a mallet to break the seal. Then pierce can with screw driver or similar pointed tool to serve as a handle for unscrewing filter from case. Place a pan under the filter to catch oil leakage when filter is removed. Refer to "Oil Filter", Page 10, for replacement instructions.

STARTING MOTOR is removed by disconnecting ignition wires at solenoid and taking out the three capscrews holding starter to flange on gear cover. **Note:** The rubber Bendix cover will drop off when flywheel shroud is removed.

FLYWHEEL (Fig. 23, Fig. 24)

After the flywheel screen has been removed, drive out the starting crank pin in the crankshaft and straighten out the bent tabs on lockwasher. By means of a 2¼" socket power wrench or 2¼" offset box wrench, as shown in Fig. 23, remove flywheel nut. Strike the handle of the wrench a sharp blow with a soft hammer to loosen nut. Do not use an open end, monkey or pipe wrench.

The flywheel is mounted to a taper on the crankshaft. Take a firm hold on the flywheel fins, pull outward and at the same time strike the end of the crankshaft several times with a babbitt hammer, see Fig. 24. The flywheel will slide off the taper of the crankshaft. Do not use a hard hammer as it may ruin the crankshaft and bearings. Remove Woodruff key from crankshaft.

In reassembly; be sure the Woodruff key is in position on the shaft and that the keyway in the flywheel is

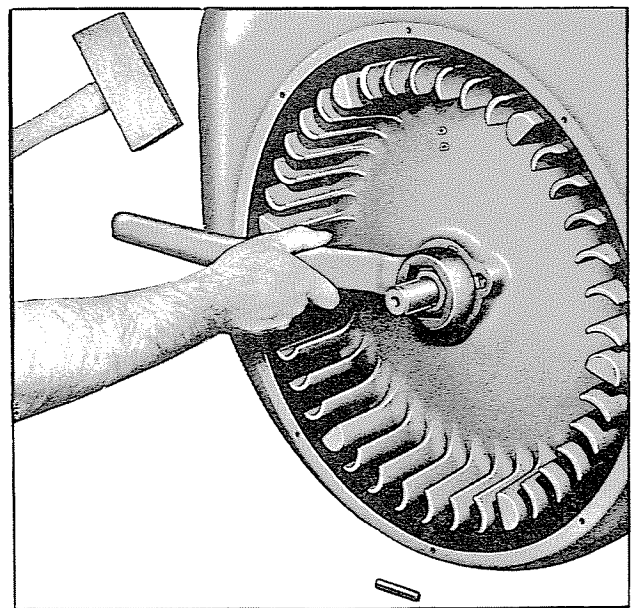

Fig. 23

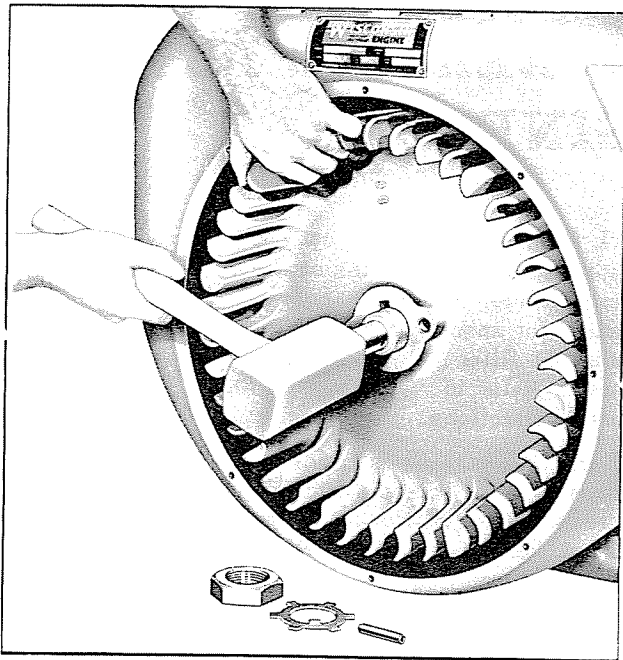

Fig. 24

lined up accurately with the key. After mounting; seat flywheel on crankshaft taper by slipping a piece of pipe over the end of the crankshaft and against the hub of the flywheel, and striking the end of the pipe a sharp blow with a hammer.

FLYWHEEL SHROUD (Fig. 25)

Remove *cylinder head covers* by dis-engaging 3 clips and taking out the thumb screw.

Disconnect No. 2 and No. 4 spark plug wires and hi-temperature switch wire. Slip wires thru grommet in shroud.

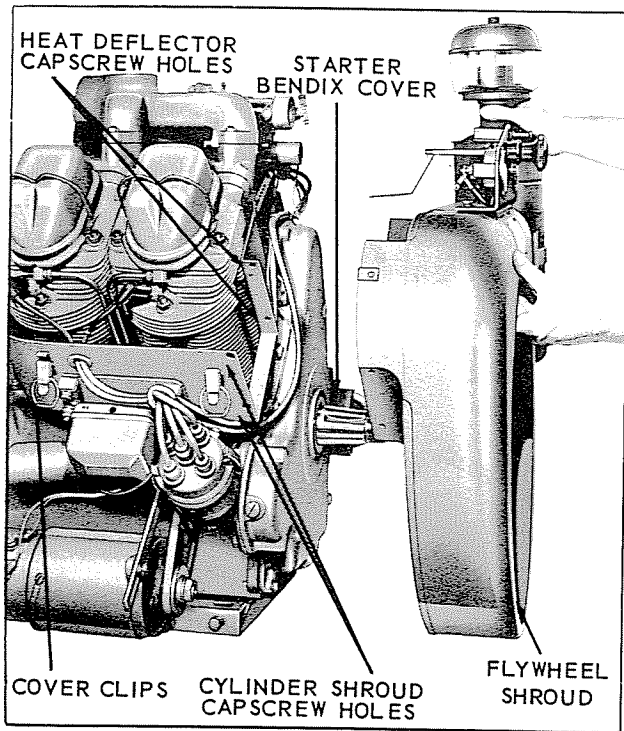

Fig. 25

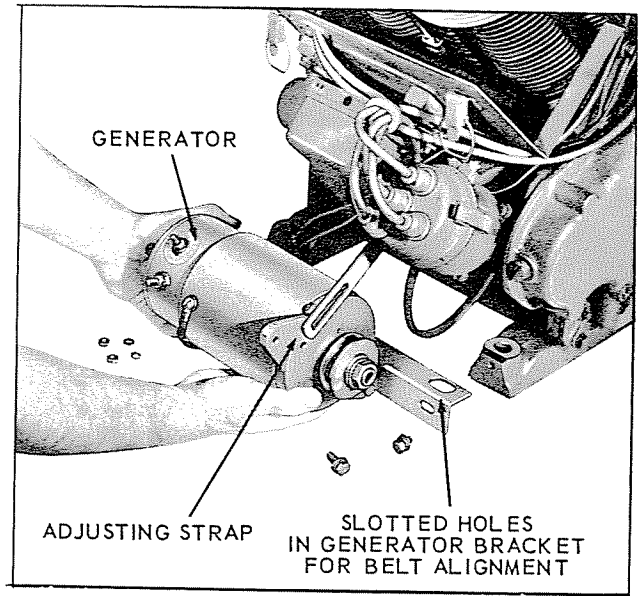

Fig. 26

Take out the following capscrews: 4 from flywheel shroud to cylinder shrouds, 4 from heat deflectors and 6 from inside flywheel shroud to gear cover. The *flywheel shroud*, air cleaner and control panel assembly can be removed as illustrated in Fig. 25.

In reassembly; insert rubber Bendix cover between flywheel shroud and starter pad on gear cover.

GENERATOR — Older Models (Fig. 26)

Disconnect ignition wires from field and armature terminals. Take out the capscrew holding the adjusting strap to generator. By taking out the 2 capscrews which hold the bracket to the engine supports, the generator can be removed as shown in Fig. 26.

Note that the holes in the generator bracket are slotted for belt alignment in reassembly.

DISTRIBUTOR AND ACCESSORY DRIVE (Fig. 27)

Disconnect ignition wire at distributor and take off distributor cap, leaving high tension cables in place. Remove 2 capscrews holding the accessory drive housing to the gear cover. As illustrated in Fig. 27, the distributor and accessory drive housing can be withdrawn from the gear cover as a complete unit.

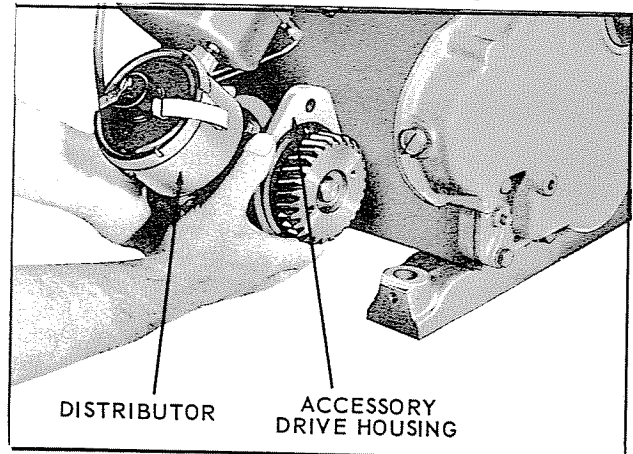

Fig. 27

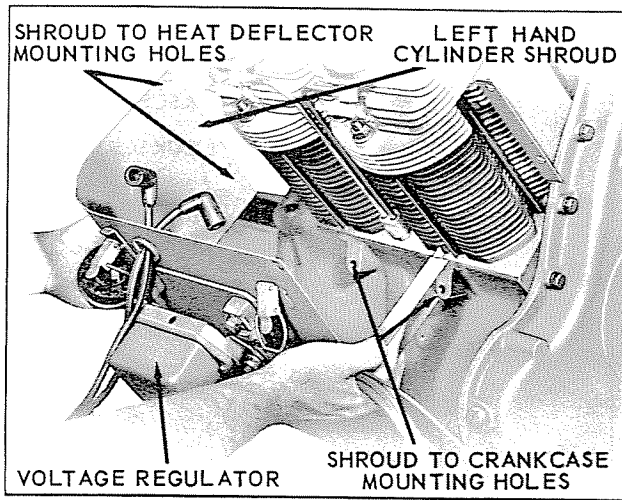

Fig. 28

CYLINDER SHROUDING (Fig. 28)

Remove ignition coil and generator adjusting strap from left hand side of engine. Disconnect No. 1 and No. 3 wires at spark plugs and remove spark plug wire clamps at top of governor housing. Take out the 2 capscrews which attach the cylinder shroud to the heat deflector at the take-off end of the engine and the 2 screws mounting the shroud to the crankcase. The left hand cylinder shroud with voltage regulator and spark plug wires attached can be removed as shown in *Fig. 28*. Right hand cylinder shroud is removed in like manner.

MANIFOLD AND CARBURETOR (Fig. 29)

Disconnect fuel line at carburetor and control rod at governor lever. Unhook governor spring and remove the 4 nuts and clamp washers which secure the manifold to the cylinder heads. The two manifold branches, carburetor and speed control bracket assembly can be lifted off as a complete unit. See *Fig. 29*.

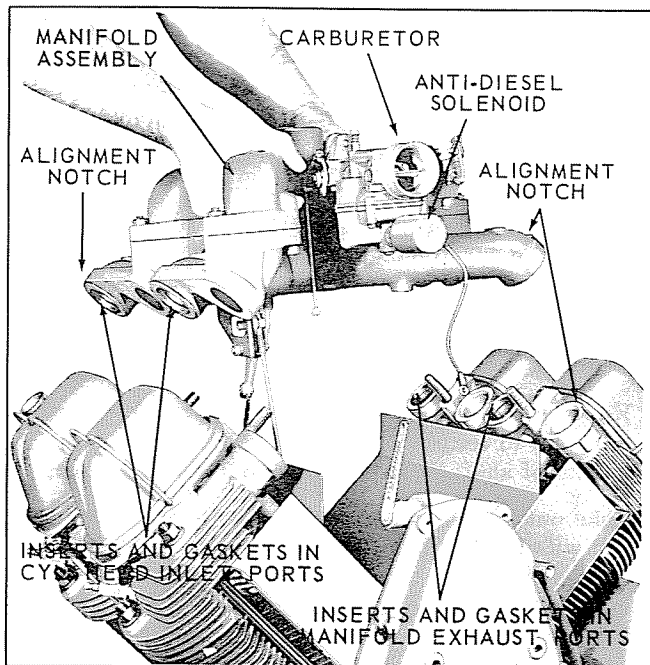

Fig. 29

Note that the exhaust manifold gaskets and inserts will remain in the cylinder head ports, whereas the inlet gaskets will stay in the manifold ports. New gaskets should be mounted accordingly in reassembly.

To prevent restriction in ports because of misalignment between the manifold and cylinder heads, there is a cast notch on top of the No. 2 and the No. 3 inlet ports of the manifold. These notches are to match up with a similar notch on the inlet port of the cylinder heads in reassembly. Tighten manifold to cylinder head nuts to **25 foot pounds torque**. The upper to lower manifold screws are tightened to **15 ft. lbs. torque** and the anti-diesel solenoid mounted to the carburetor is tightened to **100 inch pounds torque**.

FUEL PUMP

Loosen screw on heat deflector at fuel pump. Remove 2 capscrews holding pump adapter to crankcase. Swing heat deflector bracket to one side and remove complete pump adapter and strainer assembly.

GOVERNOR

Remove the 2 bottom screws holding the governor housing to the gear cover and spacer plate. Top 2 screws were removed when spark plug wire clamps were taken off. After removing governor housing, the gear and flyweight assembly can be slipped off shaft in gear cover.

In reassembly; refer to "*Governor Adjustment*", pages 17 & 18, for setting engine operating speed.

GEAR COVER (Fig. 30)

Remove capscrews from front face of gear cover and 2 screws from rear at No. 2 cylinder. Tap gear cover

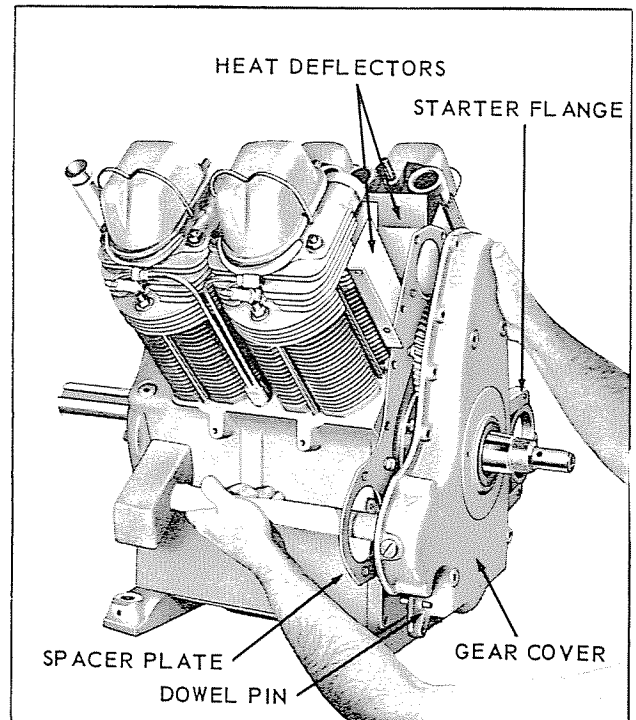

Fig. 30

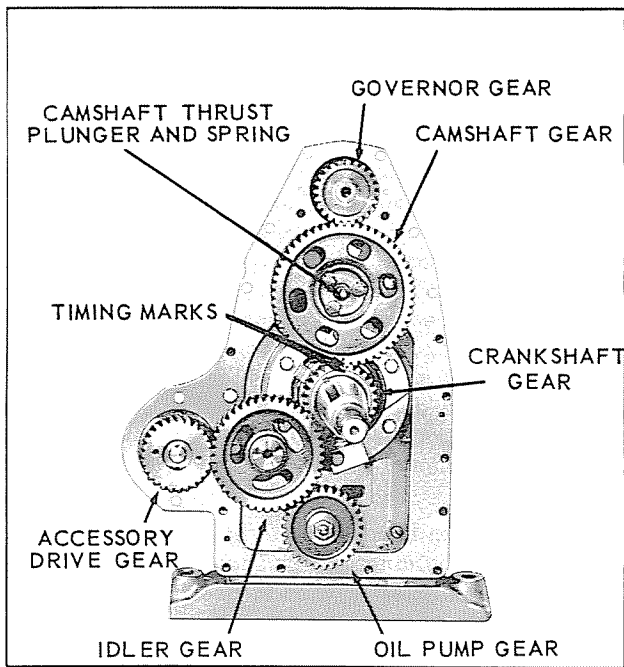

Fig. 31

alternately, from starter flange to accessory drive housing opening, and remove as illustrated in Fig. 30. Note that dowel pins will remain in cover. Cylinder heat deflectors can now be removed.

In reassembly; tighten gear cover capscrews to 18 foot pounds torque.

GEAR TRAIN (Fig. 31)

With the removal of gear cover and oil sling, the gear train will be exposed as shown in Fig. 31. Remove camshaft thrust plunger and spring to prevent their being lost.

Future reference can be made to Fig. 31 when assembling crankshaft and camshaft, as accurate location of the timing marks is essential for proper engine operation.

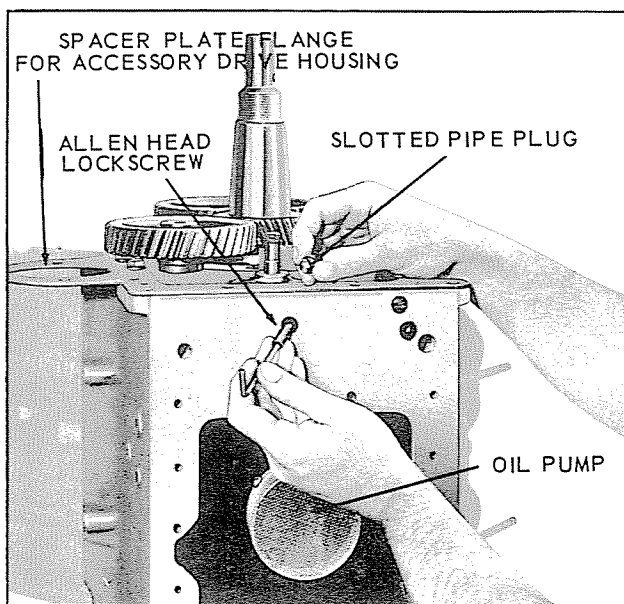

Fig. 32

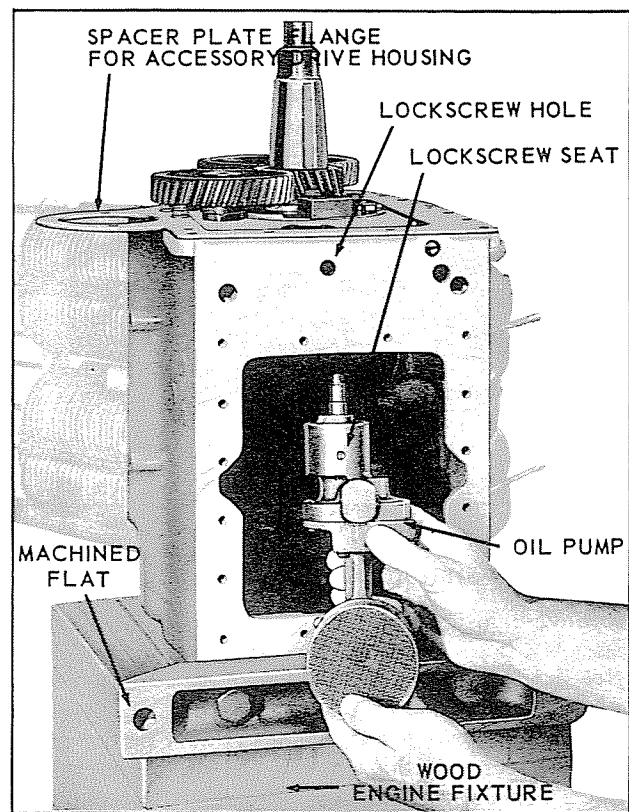

Fig. 33

ENGINE SUPPORTS AND OIL PAN (Fig. 33)

Use a work bench with a clearance hole of at least $2\frac{1}{4}$ inches in diameter for the engine crankshaft to extend thru, and tip the engine over to rest on the main bearing plate – or, if convenient, construct an engine fixture by making a box from 2 x 6 lumber as illustrated in Fig. 33. Make the box about 16 inches square x 8 inches high with a $2\frac{1}{4}$ inch clearance hole in the top, and open at the bottom.

With engine tipped over on take-off end, remove engine supports and oil pan. *In reassembly;* use a new gasket underneath oil pan, mount with oil drain toward side opposite flange on spacer plate for accessory drive housing, and tighten capscrews to 18 foot pounds torque.

Mount engine supports with machined flats toward flange side of spacer plate where accessory drive housing is mounted. Use Perma-tex on capscrews for both engine supports and oil pan. Tighten capscrews for engine supports to 40 foot pounds torque.

OIL PUMP (Fig. 32, Fig. 33)

Remove locknut and driver gear from shaft. If gear is too tight to remove by hand, use a pulley; hammering on end of shaft to loosen gear will damage pump.

Take out slotted pipe plug from bottom of crankcase, and with a $5/32$ inch Allen wrench, remove lock screw as shown in Fig. 32. Withdraw the oil pump from inside the crankcase, as illustrated in Fig. 33. If pump fits too tight to remove by hand, tap front of pump housing (not shaft), with hammer and brass rod.

In reassembly; be sure lock screw seat in pump housing lines up with lock screw hole in crankcase.

SPECIAL FEATURE

Individual cylinder heads, barrels, pistons and rings can be removed for replacement without a major engine disassembly, by means of a special piston sleeve.

Refer to Fig's. 34, 36, 37 and

Cylinder Head, Cylinder Barrel paragraphs.

CYLINDER HEAD (Fig. 34, Fig. 35)

Remove rocker arm cover by means of a screw driver wedged under the bail wire. Take off the 4 nuts and washers from cylinder barrel studs. Lift cylinder head and rocker arm assembly off cylinder. The oil drain line will slip out of adapter in crankcase. Pull out push rods and rod housings. See Fig. 34.

In reassembly; place a new 'O' ring under collar of push rod housing. Press collar end of tube into tappet hole by hand; do not drive tubes in place with a hammer. Use new 'O' ring for push rod housing to recess in cylinder head. Spread a light film of grease on cylinder head gasket so it will stick in place during reassembly. Place new 'O' ring on oil drain tube

Note: When reassembling cylinder heads on a complete overhaul, it will be necessary to square up the inlet and exhaust port flanges with those of the manifold. See Fig. 35. Place a parallel steel bar across the ports and tap the heads lightly with a rubber mallet to rotate them until they are square. Turn cylinder head nuts to a snug fit and re-check alignment. Torque cylinder head nuts alternately and in 3 steps. First 10, then 20, and finally 30 foot pounds torque.

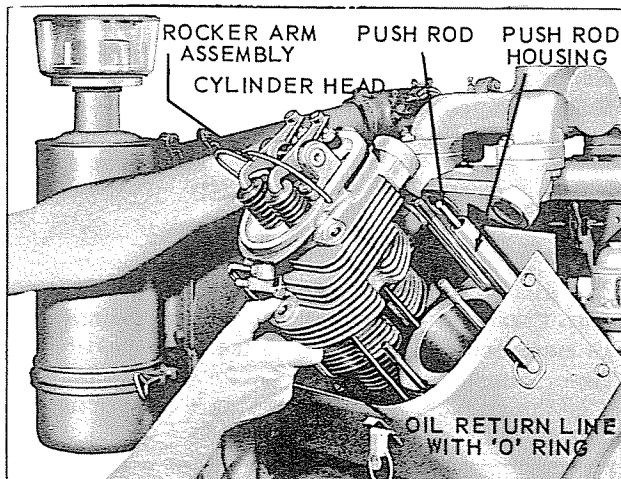

Fig. 34

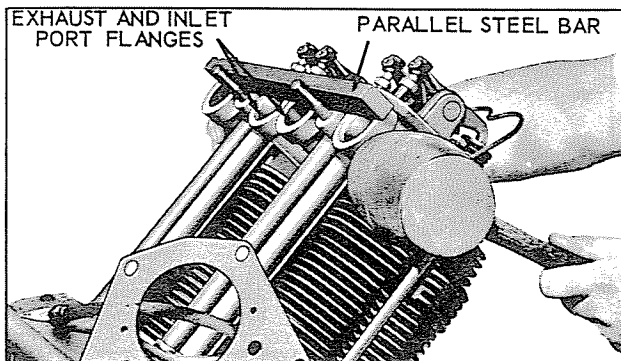

Fig. 35

Rocker arm assembly can be left bolted to the cylinder head, unless head or rocker arms need replacing.

CYLINDER BARREL (Fig. 36, Fig. 37)

Turn crankshaft over until piston, in the cylinder barrel that is to be replaced, is at the top of its stroke. Remove; top cylinder stud (flanged) on Model V-461D, or hold down clip as used on Model V-465D. The remaining studs can be disassembled after cylinder is taken off.

In reassembly; place a new gasket at bottom of cylinder barrel. It will be necessary to compress the piston rings in order to slip the cylinder over the piston, as shown in Fig. 37. A piston sleeve can be made from the lower portion of a scrap cylinder. The sleeve is 2¼ inches long with a 7/8 inch wide slot. The inside diameter is tapered from the middle to the bottom;

3.750" to 4.000 for V-465D

3.500" to 3.750 for V-461D, V-460D

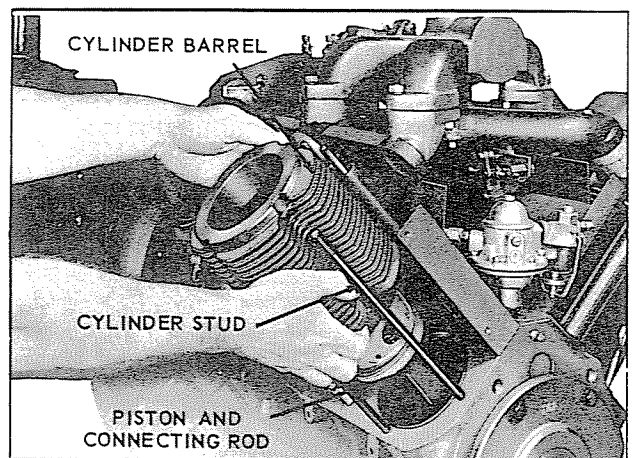

Fig. 36

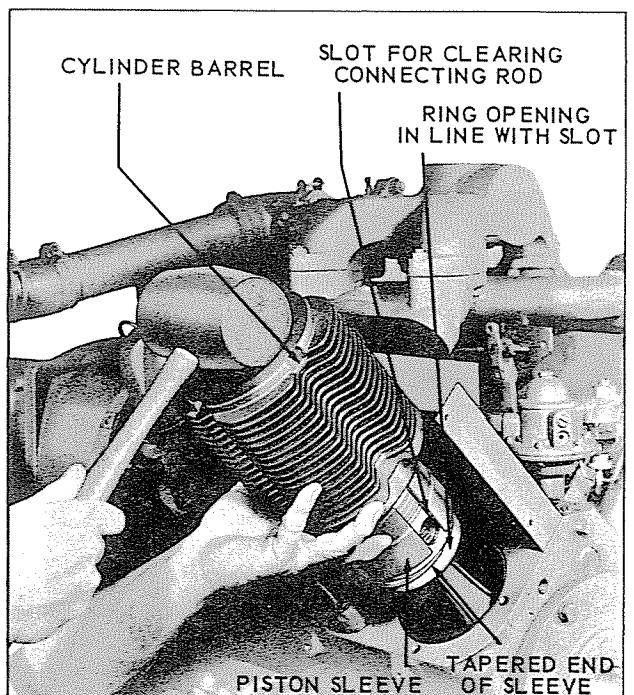

Fig. 37

Slip sleeve over and slightly below top of piston. Extension of piston out of sleeve will act as a pilot for mounting cylinder. Lubricate cylinder bore and press barrel on to piston and against sleeve. Force piston into bore by tapping cylinder barrel with a rubber mallet, as illustrated in *Fig. 37*. When bottom ring of piston is securely in cylinder, lower sleeve and remove thru slot. Continue to press barrel over piston until it is snug against crankcase. Mount cylinder studs and remainder of parts per 'Cylinder Head' paragraphs of reassembly.

CYLINDER, PISTON and CONNECTING ROD (*Fig. 38, Fig. 39*)

After removing cylinder heads and before attempting to loosen connecting rod caps, it is advisable to hold down both banks of cylinder barrels, lest they become loosened and damaged when rotating the crankshaft. This can be accomplished by means of a steel *retainer bar* and the cylinder hold down studs, as shown in *Fig. 38*.

Insert a drift punch in crankshaft crank pin hole, and turn shaft over so that the nuts for the No. 1 connecting rod cap are accessible. Take off the 2 nuts, loosen

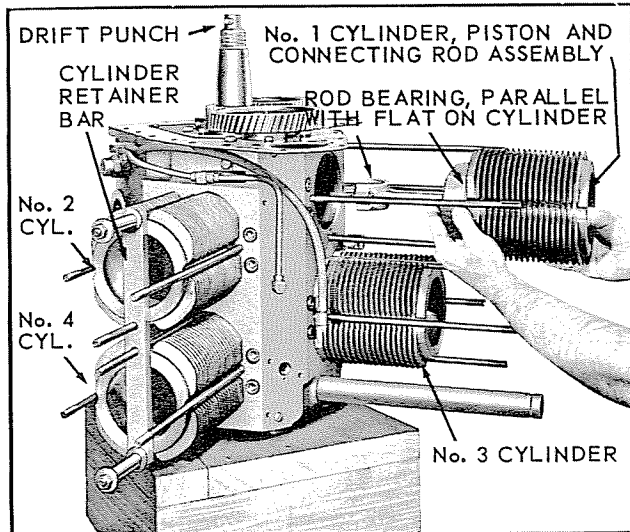

Fig. 38

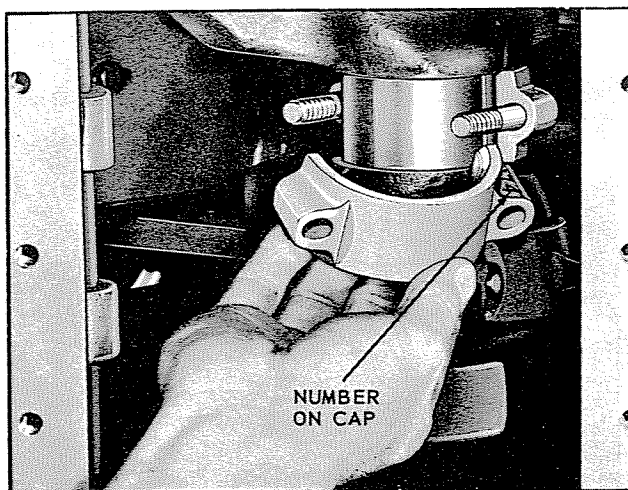

Fig. 39

and remove connecting rod cap by tapping lightly on the end of the bolts. Use a brass rod so as not to upset bolt threads. Remove cylinder retainer bar and withdraw cylinder barrel, piston and connecting rod, as illustrated in *Fig. 38*. Place cap on rod immediately so that it will not be mismatched in reassembly. Remove No. 3 cylinder assembly, and then do likewise with the No. 2 and 4 cylinder bank.

Identical numbers are stamped on the side of the rod with its corresponding cap. These numbers must be on the same side of the connecting rod in reassembly. See *Fig. 39*. Install new nuts on connecting rod bolts and torque to 32 foot pounds.

Cylinder barrels should be put back on the crankcase in the same location they were removed from. Use a new gasket at bottom of barrel. Clean all dirt and chaff from between fins and bottom of flange.

If the cylinders are worn more than .005 inch over-size, they should be reground and fitted with over-size pistons and rings. This work should be done by an authorized service station.

If in the opinion of the service station attendant, a chrome re-ring is necessary, use *Wisconsin TriCrome* piston ring set.

PISTON RINGS (*Fig's. 40, 41, 42*)

If a ring expander tool is not available, install rings by placing the open end of the ring on piston first, as shown in *Fig. 40*. Spread ring only far enough to slip over piston and into correct groove, being careful not to distort ring. Assemble bottom ring first and work upward, installing top ring last. The outer diameter of the top compression ring is *chrome plated*. Mount scraper ring with scraper edge down, otherwise oil pumping and excessive oil consumption will result. Refer to *Fig. 41* for correct placement of rings for the V-460D, V-461D and V-465D.

PISTON (*Fig. 42, Fig. 43*)

The piston skirt is *cam-ground* to an elliptical contour. Clearance between the piston and cylinder must be measured at the bottom of the piston skirt thrust face. Refer to Chart, *Fig. 42*, for proper clearance. The thrust face on the piston skirt is 90° from the axis of the piston pin hole.

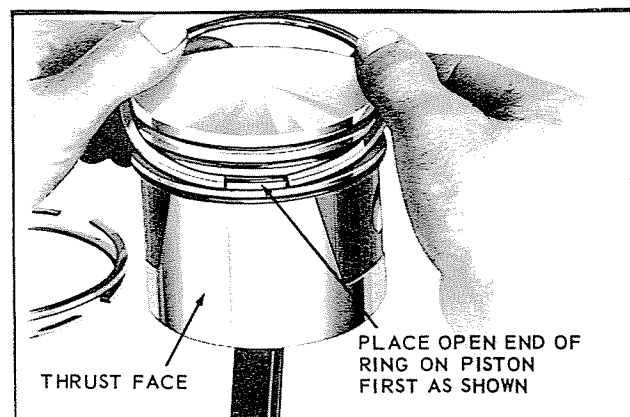

Fig. 40

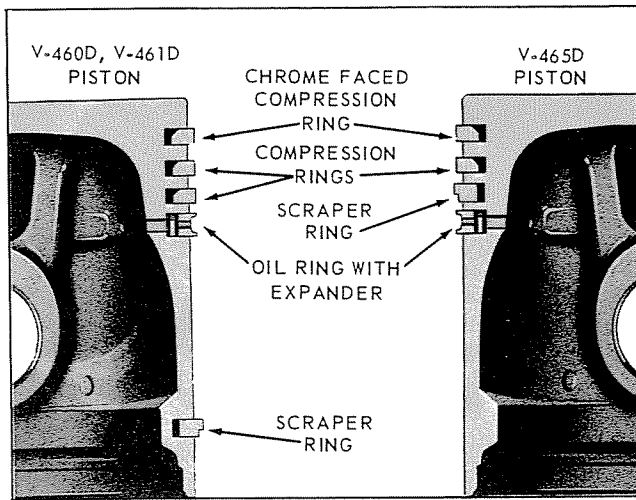

Fig. 41

CYLINDER BORE	Models V-460D, V-461D 3.498 to 3.499"	Model V-465D 3.748 to 3.749"
PISTON TO CYLINDER AT PISTON SKIRT THRUST FACES		.0025 to .003"
PISTON RING COMPRESSED GAP		.008 to .024"
PISTON RINGS – SIDE CLEARANCE IN GROOVES		.002 to .004"
CONNECTING ROD TO CRANK PIN – SIDE CLEARANCE		.008 to .016"
CONNECTING ROD SHELL BEARING TO CRANK PIN		.0005 to .0018"
PISTON PIN TO CONNECTING ROD BUSHING		.0005 to .0011"
PISTON PIN TO PISTON		.0000 to .0008" tight
CENTER MAIN SHELL BEARING TO CRANKSHAFT JOURNAL		.0013 to .0038"

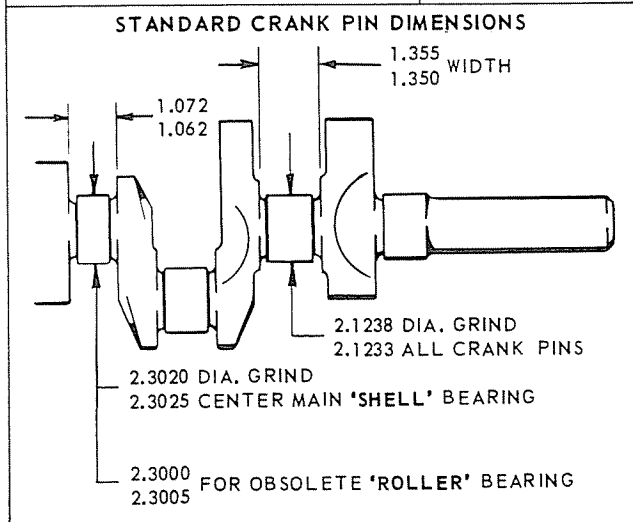

Fig. 42, PISTON, RING AND ROD CLEARANCE CRANKPIN AND CENTER BEARING DIMENSIONS

Piston and connecting rod is sub-assembled to the cylinder barrel and the complete unit is mounted to the crankcase. Lubricate the piston assembly and cylinder walls with No. 30 S.A.E. oil, and stagger the ring gaps 90° around the piston. Use a standard

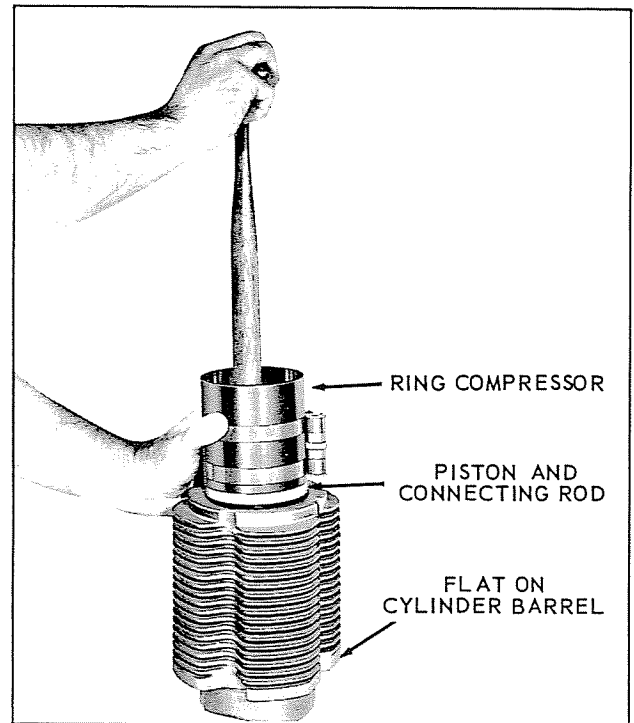

Fig. 43

automotive type ring compressor, and insert rod end into cylinder from cylinder head end. **Note:** Rod bearing should be parallel to flats at base of cylinder barrel for correct assembly to crankshaft, see Fig. 38. Gently tap piston into cylinder and to bottom of bore. Use the wooden handle end of hammer, as shown in Fig. 43.

VALVES (Fig. 44)

Replace valves that are burned or pitted. A leaky valve can usually be determined by a 'hissing' noise in the exhaust or intake manifold when cranking the engine slowly by hand.

The exhaust valves are furnished with **positive type rotators**. Refer to *Illustrated Parts Catalog* for mounting. The valve rotates slightly each time it opens, and thereby prevents the build up of foreign deposits on the valve face and stem. Clean and inspect operation of rotators — replace if faulty.

Valve grinding should be done by an authorized service dealer, since he has the necessary equipment and experience to do a good job. To remove valves; use a standard automotive valve lifter as illustrated in Fig. 44, and remove spring seat locks. Release valve lifter and take out valve, spring and exhaust rotator or spring seat.

The valve face is ground at 45° to the vertical center line of the valve stem and the valve seat insert should also be ground at a 45° angle. After grinding, valves and inserts should be lapped with a suitable lapping compound or they will leak due to improper seating, within the first few hours of operation. While lapping, occasionally lift the valves and reset them

in a different position to insure a uniform seat entirely around the valves. After valves have been lapped in evenly, remove and wash both valves and head thoroughly with kerosene and re-assemble.

VALVE GUIDES. The valve stem has a clearance of .002" to .004" in the guide. When clearance becomes .006", the guide should be driven out and a new guide pressed in place. Allow 1/32" to 1/64" clearance between valve guide boss and bottom of valve guide shoulder. Check guide for .3440/.3445" I.D. after pressing in place. Ream if necessary.

VALVE SEAT INSERTS are not replaceable, due to method of installing. If seat inserts become worn and ground down to the extent that the seats are wider than the valve face, replace cylinder head.

ROCKER ARM ASSEMBLY (Fig. 44)

Very little wear will occur to the rocker arms as long as they are adequately lubricated. If replacement is necessary, remove the complete rocker arm bracket assembly, Fig. 44, from cylinder head. Take out shaft setscrew from bottom of bracket with a 1/8" Allen

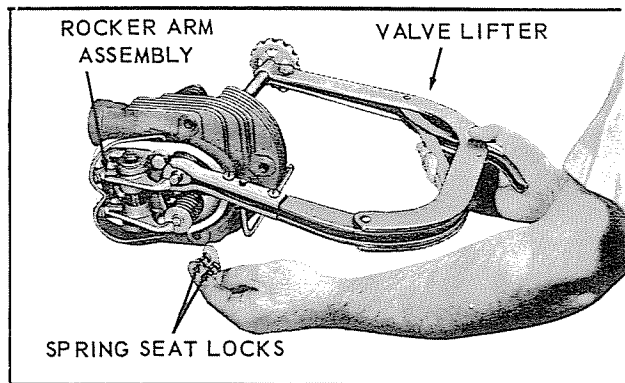

Fig. 44

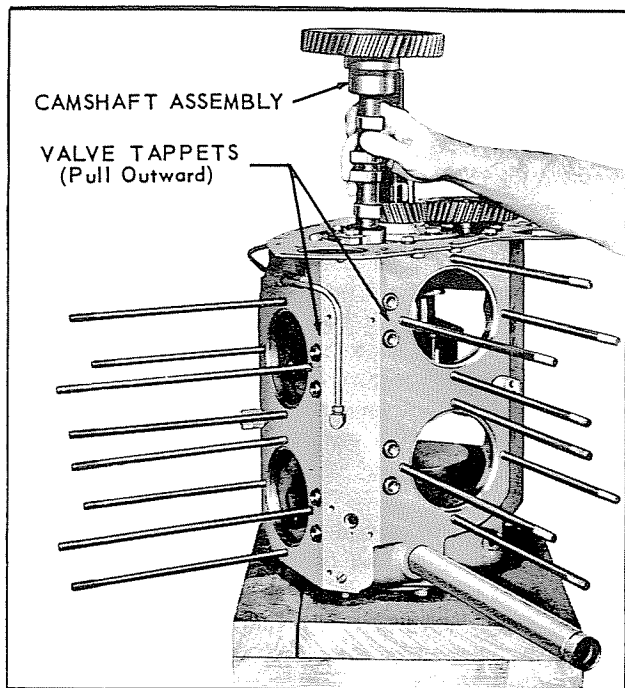

Fig. 45

wrench, and tap shaft out toward setscrew end of bracket, using a brass rod. **NOTE:** Beginning with serial # 5634850, setscrew is secured in place with # 271 Loctite in place of staking. To loosen setscrew for removal, apply heat (400 °F) to setscrew.

In reassembly; flat surface on shaft for setscrew must line up with tapped hole in bracket. Apply # 271 Loctite to setscrew threads and securely tighten in place. Lubricate shaft so that rocker arm bearings will not operate dry when starting engine.

CAMSHAFT (Fig. 45, Fig. 46)

Pull tappets outward to clear lobes for camshaft removal. Withdraw tappets from inside crankcase. *In reassembly,* clean, lubricate tappets and insert thrust plunger and spring into end of camshaft, See Fig. 46.

The *camshaft gear* has offset mounting holes to provide accurate assembly for valve timing. The gear can only be put on the correct way for matching up the timing mark with that of the crankshaft. See Fig. 46.

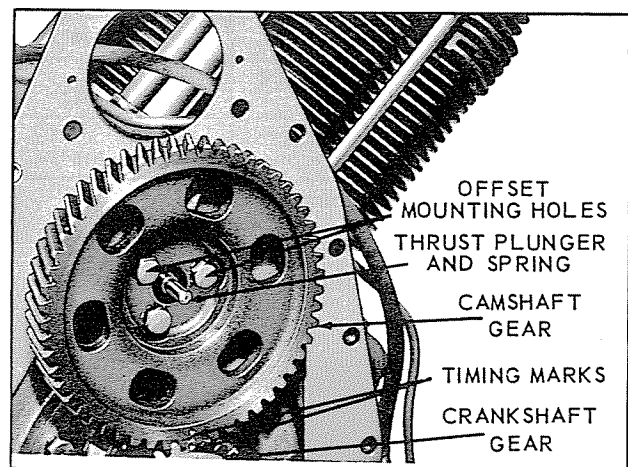

Fig. 46

CENTER MAIN BEARING (Fig. 47, Fig. 48) V-465D

Note: Beginning with engine serial No. 4904657, a *shell type center main bearing* replaces the *split roller bearing*. The bearing and hanger assemblies are *not interchangeable* for service replacement unless the complete crankshaft assembly is changed and the crankcase modified.

The following instructions apply to the current production engines with shell center main bearing. Refer to Page 32 for overhaul procedures relative to the now *obsolete roller type center main bearing* and crankshaft oil collet.

Caution: Do not attempt to remove crankshaft from engine without first removing center bearing hanger.

With reference to Fig. 47, disconnect *oil pressure line* at center bearing hanger and at oil header behind filter, by using a 1/2 inch hex tubing nut wrench. Remove hanger to case screws and washers. Then loosen and back out cap to hanger screws about 1/2 inch. Tap screw heads lightly and alternately with a hammer to break cap away from hanger body.

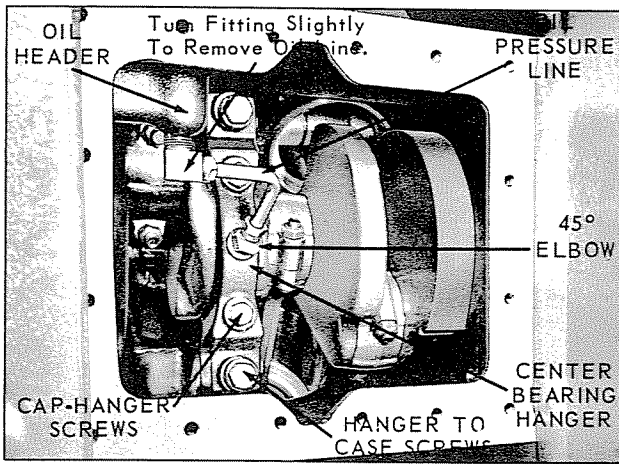

Fig. 47

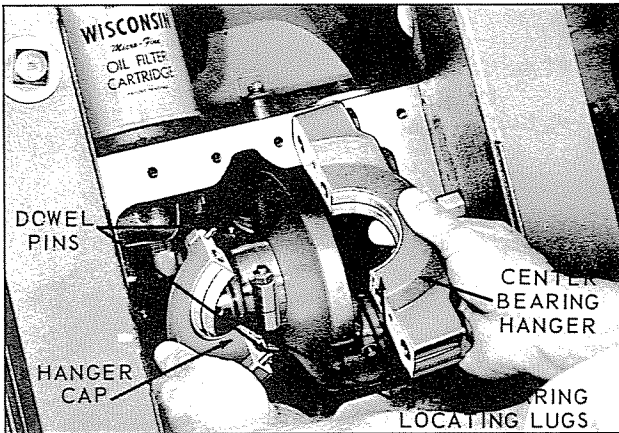

Fig. 48

Do not pry cap and body apart. Separate and remove hanger and cap with shell bearing from crankcase.

Check bearing and crankshaft journal for visible wear — see *Clearance Chart, Fig. 42*. If clearance approaches .005 inch, replace shell bearing with suitable undersize.

In reassembly: Clean thoroughly and apply a film of oil to the bearing surfaces. *Mount* center main bearing *after crankshaft* is assembled to crankcase and *end play* is set.

Dowel pins in cap are off-center so that when hanger is mounted to cap, the locating lug on both bearing halves, will be on the same side. See *Fig. 48*. Assemble hanger so that 45° oil line elbow is facing toward oil header side of case as illustrated in *Fig. 47*.

Draw cap to hanger screws finger tight until the two dowels are just entering holes. With a hand wrench, alternately turn each screw 1/2 to 3/4 turns to evenly pull cap tight to hanger body. *Torque* screws 32 to 35 foot pounds.

Secure bearing hanger to crankcase after crankshaft end play is set. Install capscrews and washers. The tightening torque of the two bolts which fasten the center main bearing assembly to the crankcase of the V465D has been increased to 74-76 LB-FT. Engines built after SN 6279801 will have the greater torque applied. This change takes advantage of the greater available strength of the grade 8 socket head capscrews PN XB120.

For service, engines after SN 6089641 can use the new torque specification. Also, engines built prior to that can use the newer style grade 8 capscrew (PN XB120, 7/16-14 x 2 1/2 socket head) and can then also use the new higher torque

specifications. *Note: Older engines were fitted with XD130 7/16-14 x 2 1/4" hex head grade 5 capscrew which were torqued to 60 foot pounds.*

Be sure oil fitting passages are clean. Connect oil line from header to bearing hanger.

MAIN BEARING PLATE and CRANKSHAFT (Fig. 49)

Remove main bearing plate, gaskets and shims from take-off end of engine. Slip a length of pipe over the gear end of the crankshaft and with the assistance of another person, withdraw the shaft thru the main bearing plate opening, as illustrated in *Fig. 49*. Removal of crankshaft *with center bearing hanger assembled* to it applies only to the obsolete split roller bearing. *Caution: It will be necessary to rotate the crankshaft so that counterweights clear the center main bearing hanger lugs in crankcase.*

In reassembly: Holes for the main bearing plate are off-set for correct mounting. Assemble main bearing plate, gaskets and shims, and *torque* capscrews to 32 foot pounds. Check *end play* and add or remove gaskets to give the necessary .002 to .005 inch movement, with engine cold.

IDLER GEAR AND SHAFT (Fig. 49, Fig. 52)

A tapped hole in the side of the crankcase contains 2 setscrews for locking idler shaft in place. See *Fig. 49*. Remove screws with a

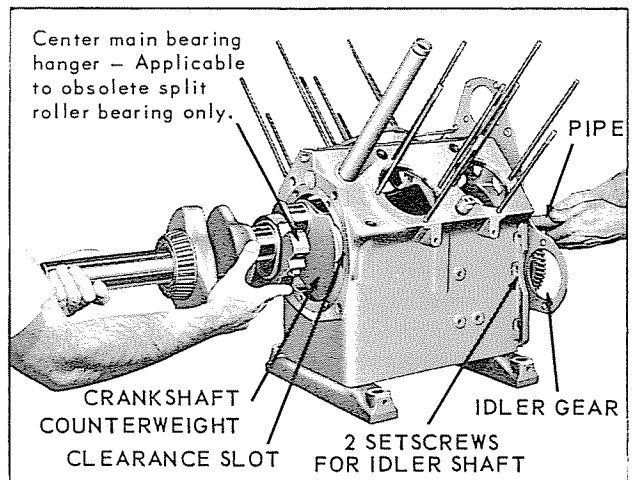

Fig. 49

5/32" Allen wrench. Disassemble shaft and gear from case by means of the 3/8"-16 tapped puller hole in end of idler shaft.

In reassembly; be sure oil groove in shaft is facing up. Drive shaft into crankcase with soft metal hammer and maintain a .003 to .004 inch clearance between idler gear and shoulder of shaft, see *Fig. 52*. Lock shaft in place with the 2 Allen set screws.

OIL PRESSURE RELIEF VALVE (Fig. 3, Fig. 50)

If it becomes necessary to remove the oil pressure relief valve, illustrated in *Fig. 50*, either for cleaning or replacement; first unscrew hex adapter and remove expansion plug from adapter. With a 3/16 inch Allen wrench, remove outer adjustment lock screw, see *Fig. 3*. Insert a 1/4 inch rod into the cross hole in valve body and turn counter-clockwise for removal. *Do not* use a pipe wrench or pliers to remove valve body.

In reassembly; use new 'O' ring in valve body and apply sealer to threads of hex adapter. Assemble ex-

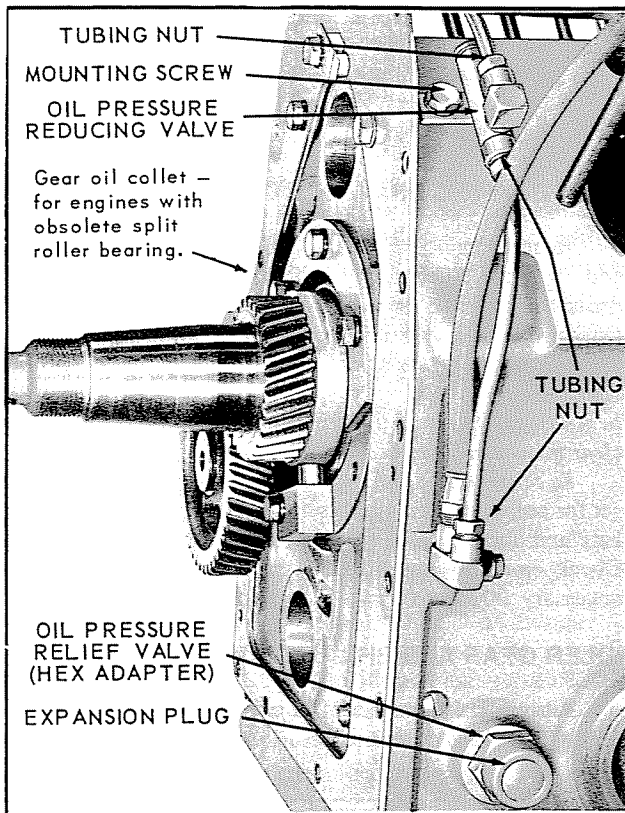

Fig. 50

Expansion plug after adjusting pressure as per "Oil Pressure and Adjustment", pages 10 & 11.

OIL PRESSURE REDUCING VALVE (Fig. 50)

To replace the oil pressure reducing valve, loosen the 4 oil line nuts at the valve and at the fittings on top and side of crankcase. Remove valve mounting cap-screw and lift valve away from crankcase. The oil lines will become unseated without being deformed.

In reassembly; hold valve in proper location but do not mount. Place oil lines in position and engage tubing nuts 2 to 3 turns. Secure valve in place with capscrew and then tighten tubing nuts.

ASSEMBLY and DISASSEMBLY PROCEDURE with obsolete ROLLER type CENTER MAIN BEARING (Engines previous to serial No. 4904657)

With reference to Fig. 51, remove oil coupling from crankshaft oil collet. Take out the adapter mounting screw and slip oil coupling out of collet. *In reassembly;* use new 'O' ring seals at both ends of the coupling and on the shoulder extending into the crankcase. Lubricate 'O' rings for ease in assembly.

Remove the center main bearing hanger to crankcase mounting screws and spacers. Tip case back on engine supports and remove main bearing plate, gaskets and shims. Slip a length of pipe over the gear end of the crankshaft and with the assistance of another person, *withdraw crankshaft with center bearing* thru the main bearing plate opening, as illustrated in Fig. 49.

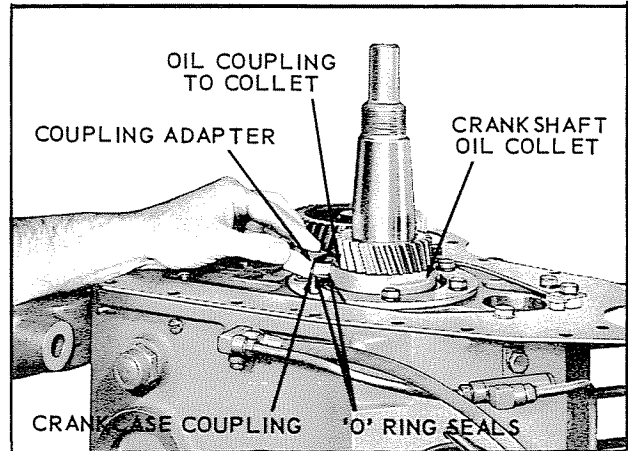

Fig. 51

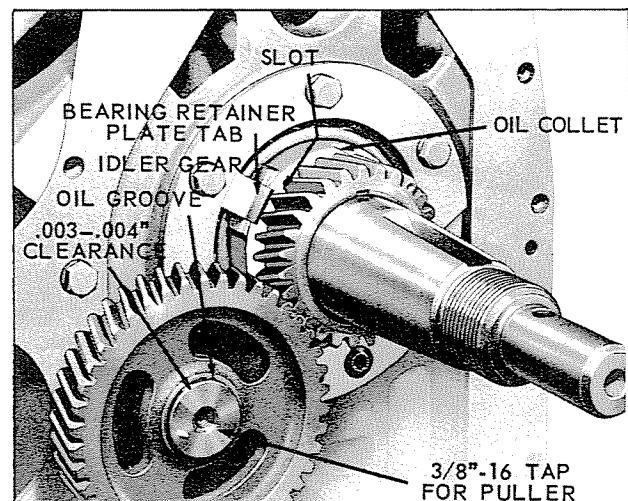

Fig. 52

Caution: It will be necessary to rotate the crankshaft so that counterweights clear the lugs in the crankcase for the center main bearing, and the lugs on the center bearing hanger will have to line up with the clearance slots in the crankcase face.

In reassembly; rotate crankshaft oil collet so that slot engages with tab on bearing retainer plate, as illustrated in Fig. 52. Mount main bearing plate, gaskets and shims, and *torque* capscrews to 32 foot pounds. Check *end play* and add or remove gaskets to give the necessary .002 to .004 inch movement.

Center main bearing (roller type) can be disassembled in the following manner: Loosen and back out bearing hanger capscrews approximately 1/2 inch. Tap capscrew heads lightly and alternately with a hammer, as illustrated in Fig. 53, to break cap away from hanger body. *Do not pry cap and body apart.* Remove capscrews and separate hanger and cap from bearing. Take off retaining ring from outer bearing race and remove bearing halves and rollers from crankshaft.

In reassembly; coat inside of bearing halves with a low melting point grease or petroleum jelly. *Do not use a standard lubricating grease.* With reference to Fig. 54, press 16 rollers into the grease of each of the bearing halves; assemble to crankshaft and clip

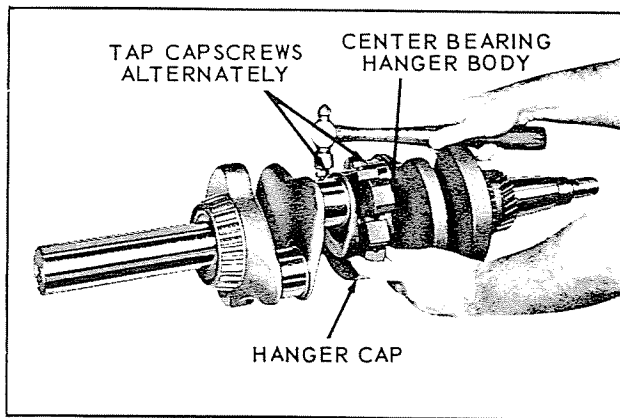

Fig. 53

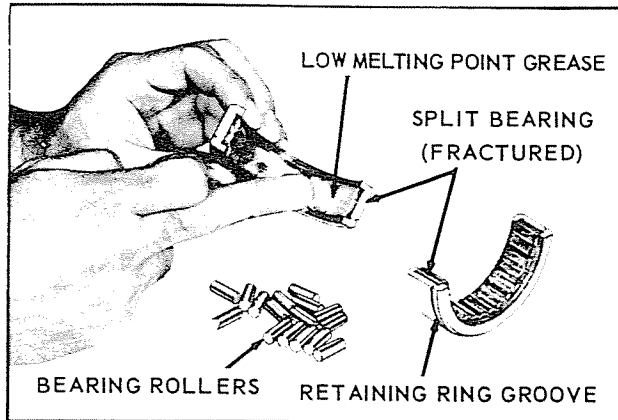

Fig. 54

together with retaining ring. The ring must overlap both mating edges of the bearing. Insert shouldered dowel pin into either hole of the bearing race and place the hanger body against the bearing so the dowel slips into the dowel pin hole, *see Fig. 55*. Hold hanger body against bearing, place cap in position and draw the capscrews finger tight until the 2 dowels are just entering holes. With a hand wrench, alternately turn each screw $\frac{1}{2}$ to $\frac{3}{4}$ turns to evenly draw cap tight to hanger body. *Torque* capscrews to *40 foot pounds*, alternately in 3 stages; 15, 30 and 40 ft/lbs. A few squirts of oil in the hanger cap oil hole will help to dissolve the bearing grease.

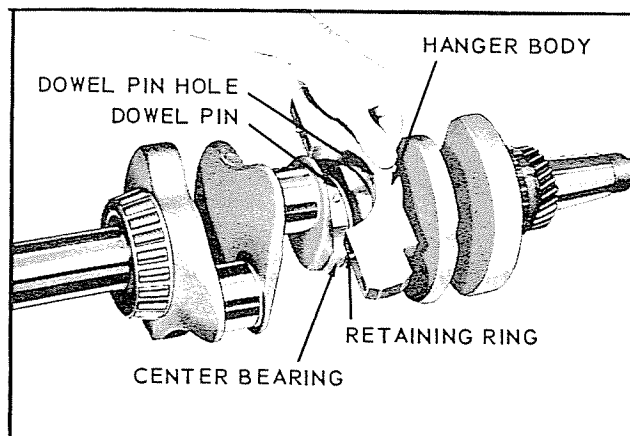

Fig. 55

Secure bearing hanger to crankcase after crankshaft end play is adjusted. *Note*: Beginning with engine serial No. 4052826, the capscrews for mounting the bearing hanger to crankcase were lengthened to 3 inches, and a spacer added under the screw heads, *see Fig. 56*. Thus all 4 screws for the center main bearing hanger assembly are the same, minimizing the possibility of improper assembly. Install hanger capscrews, with spacers, finger tight and position bearing hanger so that there is a minimum of *.040 inch* clearance between the sides of the bearing hanger and crankshaft cheeks. Tighten hanger to crankcase capscrews, *60 foot pounds torque*.

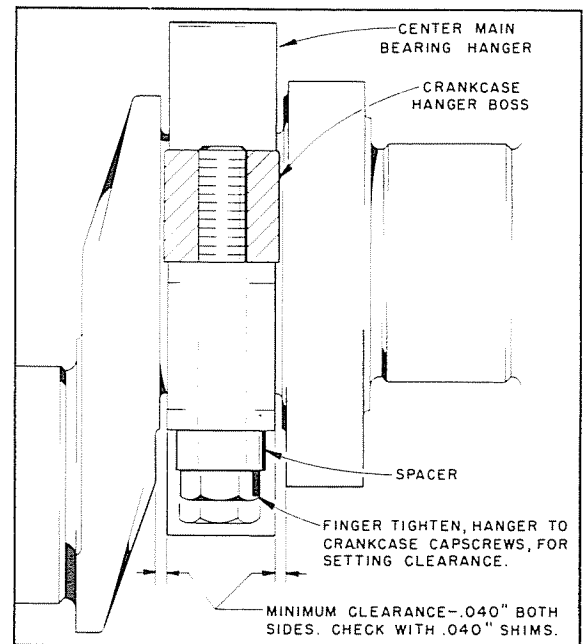

Fig. 56
BEARING HANGER CLEARANCE
(For obsolete center main roller bearing)

YB-85A ALTERNATOR

REPLACED YB-69 BEGINNING WITH ENGINE S/N 6070163

WISCONSIN Engine Model V-465D

SERVICE INSTRUCTIONS

SPECIFICATIONS

VOLTS - 12

VENTILATED - Yes

RATED OUTPUT - 37 Amperes

BRUSHES - 2

CONTROL - Voltage Regulator

ROTATION - Clockwise at drive end

LUBRICATION - Bearings are pre-lubricated. No additional lubrication necessary.

PRECAUTIONS:

Observe proper polarity when installing battery; negative battery terminal must be grounded. Reverse polarity will destroy the rectifier diodes in alternator.

As a precautionary measure, disconnect ground battery terminal when charging battery in vehicle. Connecting charger in reverse will destroy the rectifier diodes in the alternator.

Do Not, under any circumstances, short the field terminal of the alternator to ground, as permanent damage to the regulator may occur.

Do Not, remove the alternator from the vehicle without first disconnecting the grounded battery cable.

Do Not, operate engine with battery disconnected, or disconnect the alternator output lead while the alternator is operating, as damping effect of the battery will be lost. The voltage will rise to an extreme value and permanent damage to the regulator may occur.

Do Not, disconnect the voltage regulator while the alternator is operating, because the large voltage transient that occurs when disconnection takes place may damage the regulator.

Caution: Output wires from Alternator to Ammeter, and from Ammeter to battery terminal on starting solenoid must be of sufficient size for charging 37 amps. Use No. 10 gaw stranded wire, or larger.

WIRING DIAGRAM

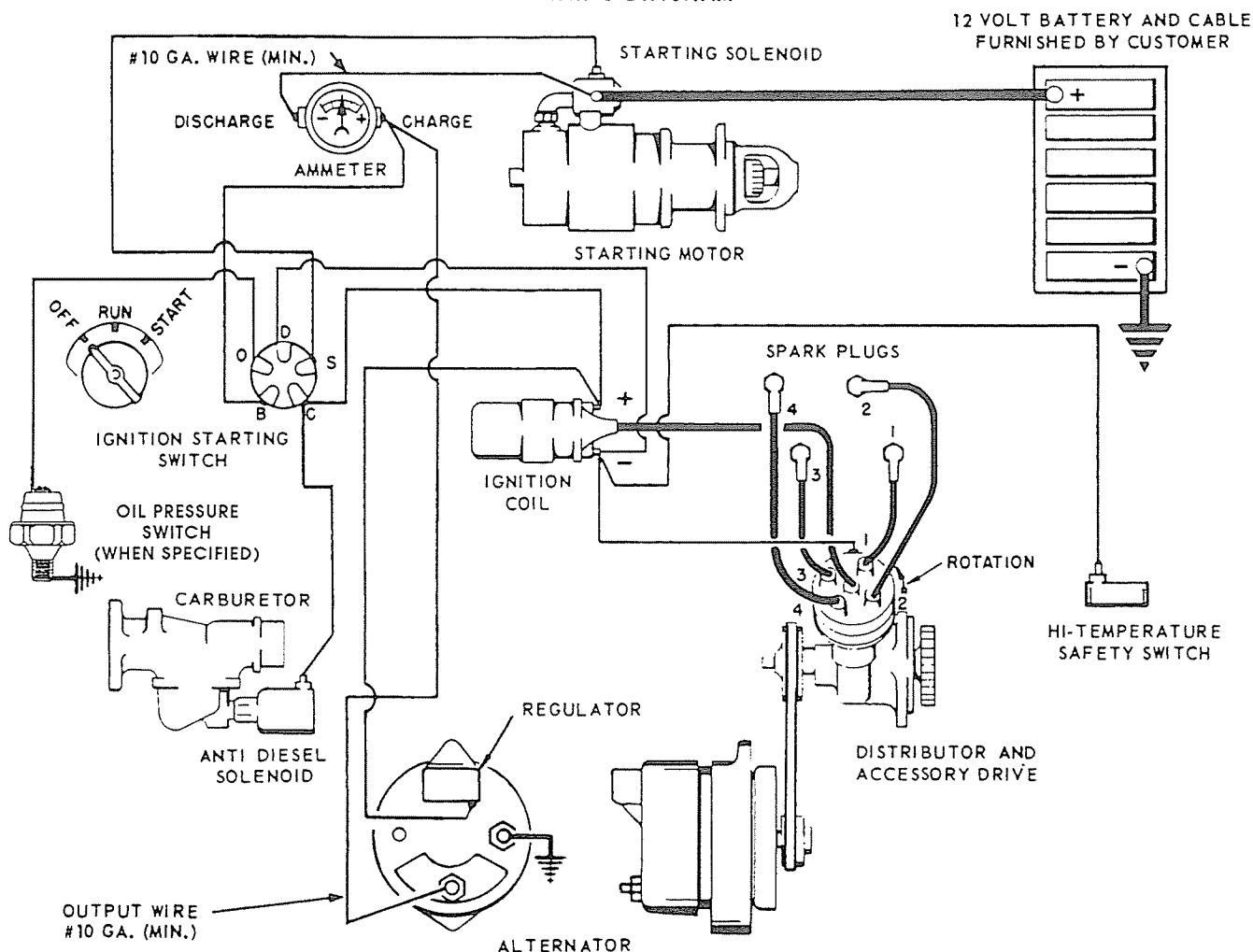

 **TELEDYNE TOTAL POWER**

MEMPHIS, TENNESSEE 38181-1160

SERVICE INSTRUCTIONS

DESCRIPTION

The Zenith 87-Series is a horizontal carburetor with a concentric fuel bowl. It is a "balanced" carburetor, because all air for fuel chamber and metering well ventilation and idling must come through the air cleaner. Air cleaner restrictions have a minimum influence on the fuel-air ratio when a carburetor is thus "balanced".

The main jet and discharge jet are centrally located. The metering well which completely surrounds the discharge jet is in the center of the fuel bowl assembly. This construction permits extremely high angle operation in any direction.

The venturi, which is part of the throttle body casting, measures the volume of air that passes through the carburetor. In selecting the venturi size, the smallest size that will permit full power development should be used.

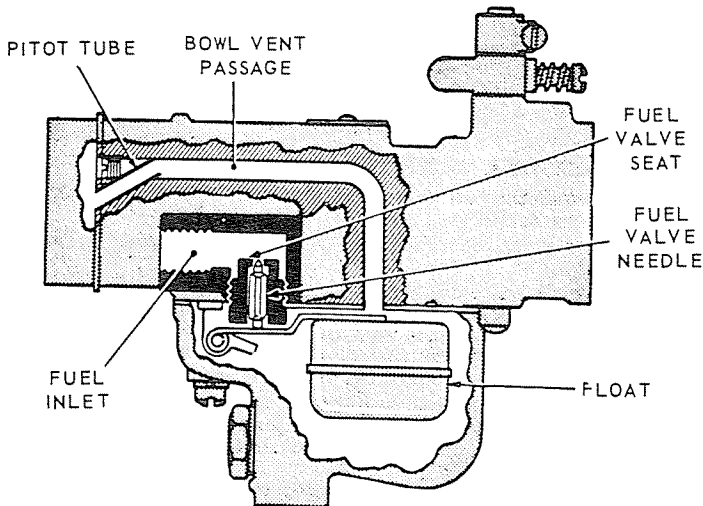

Fig. 1 FUEL SUPPLY SYSTEM

OPERATION**FUEL SUPPLY SYSTEM (Fig. 1)**

Fuel under normal pressure entering the float chamber through the fuel valve seat is controlled by the twin float which, moving on its axle, closes the needle valve when the fuel reaches the proper level in the bowl.

IDLE SYSTEM (Fig. 2)

At idling speeds the throttle plate is almost closed, thus a very high suction exists at the edge of the throttle plate where the idle discharge holes are located. All fuel for idling and part throttle operation is supplied through the

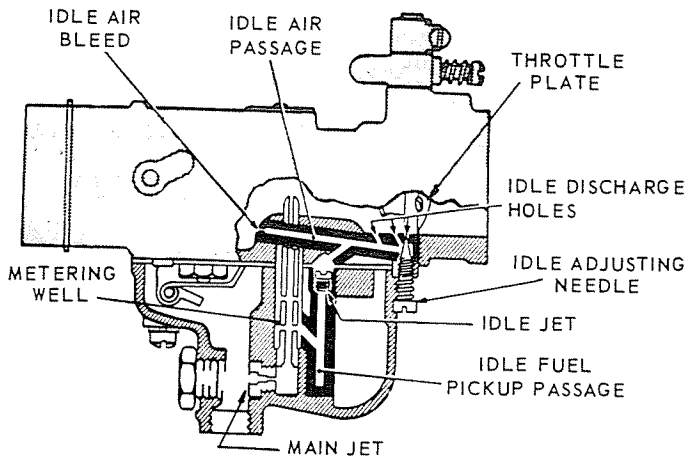

Fig. 2 IDLE SYSTEM

main jet. Fuel from the float chamber flows through the main jet into the metering well. Fuel for idling is drawn from this well through the calibration, or metering orifice, in the center of the idling jet. As the fuel reaches the idling channel it is mixed with air which is admitted through a calibrated orifice in the channel from the inside of the air intake to form an emulsion. This emulsion is discharged into the air stream, to form the idling mixture, through two holes one of which is controlled by the idle adjusting needle. Turning the adjusting needle counter-clockwise (out) permits more of the emulsion to reach the air stream and make the idling mixture richer while turning the needle in (clockwise) cuts off the amount of the emulsion reaching the air stream and makes the mixture leaner.

HIGH SPEED SYSTEM (Fig. 3)

As the throttle is opened, the suction on the idling system diminishes, but the increased volume of air entering the engine through the venturi creates sufficient vacuum (suction) on the discharge jet to draw an emulsion of fuel and air from the metering well which receives its fuel from the main jet and its air from the well vent. The flow characteristics of the discharge jet are influenced by the size, location, and number of holes in the sides of that part of the jet which is in the metering well, as well as by

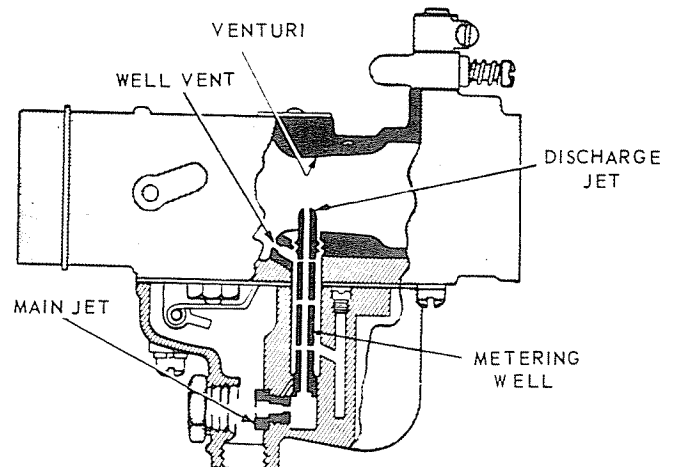

Fig. 3 HIGH SPEED SYSTEM

the sizes of the discharge jet orifice, the size of the main jet, and the size of the well vent. The well vent is located in the air intake and permits air to enter the top of the metering well around the outside of the discharge jet. The flow of fuel through the main jet is controlled by the size of main jet opening.

CHOKE SYSTEM (Fig. 4, Page 37)

Starting a cold engine requires a much richer mixture of fuel and air. Moving the choke lever to close the choke plate restricts the air entering the carburetor (except at the pitot tube, Fig. 1, to the bowl vent) and increases the suction on the idling system which makes the mixture richer.

STARTING THE ENGINE

Before cranking the engine, the carburetor throttle should be opened a little to expose both idle discharge holes to suction. The choke should be fully closed until the engine starts, then opened a little to prevent stalling from being over-choked, then when the engine is fully warmed up the choke can be returned to wide open position and the throttle closed to the idling position.

ADJUSTMENTS

Adjust the throttle stop screw to obtain the desired idling speed by turning screw in (clockwise) to increase speed and out (counter-clockwise) to decrease engine speed.

CARBURETOR

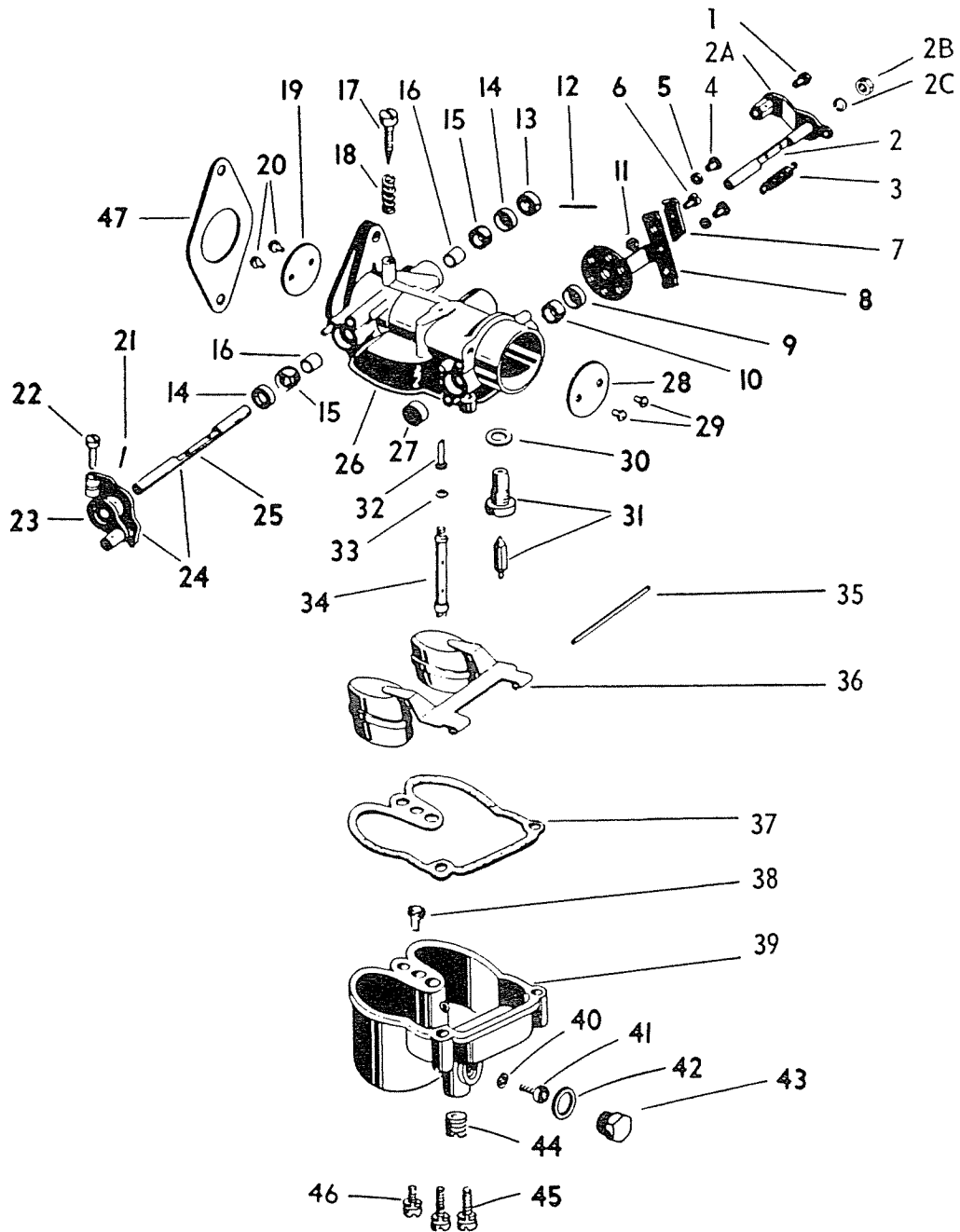

ZENITH MODEL 87A8

CARBURETOR

Adjust the idle adjusting needle to obtain smooth idling of the engine at idling speed. Turn the needle out (counterclockwise) to make the mixture richer, and in (clockwise) to make it leaner.

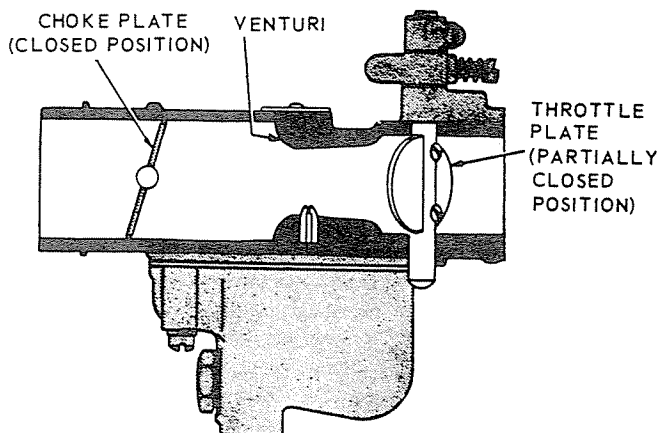

Fig. 4 CHOKE SYSTEM

SERVICE AND REPAIR PROCEDURE

IDENTIFY CARBURETOR

Check the numbers on the metal identification disc pinned to the top of the throttle body or indented in it. The plain number is the Zenith assembly number, the number with the letter "L" pre-fixed to it is Teledyne Wisconsin Motor's part number for the complete assembly.

EXPLODED VIEW (Page 36)

The exploded view identifies the serviceable component parts of the carburetor and shows their relationship to the complete assembly. Use the key numbers on the exploded view to identify and locate parts when performing both the disassembly and assembly operations.

DISASSEMBLY

SEPARATE CARBURETOR BODIES

Remove the three bowl assembly screws (45, 46) and separate fuel bowl (39) from throttle body (26).

DISASSEMBLE FUEL BOWL

1. Remove the main jet plug (43) and fibre washer (42), using a 9/16" open end wrench.
2. Remove the main jet (41) and fibre washer (40), using Zenith Tool No. C161-83 main jet wrench.
3. Remove the Idle Jet (38), using a small screwdriver.
4. Remove the bowl drain plug (44).

DISASSEMBLE THROTTLE BODY

1. Remove the float axle (35) by pressing against the end with the blade of a screwdriver.
2. Remove the float (36).
3. Remove the fuel valve needle (31), using the fingers.
4. Remove the fuel bowl to throttle body gasket (37).
5. Remove the main discharge jet (32), using a small screwdriver.
6. Remove the fuel valve seat (31) and fibre washer (30), using Zenith Tool No. C161-85.
7. Remove the idle adjusting needle (17) and spring (18).

CLEANING

Thoroughly clean all metal parts in Bendix Metalclene or Speedclene and rinse in cleaning solvent. Blow out all passages in throttle body and fuel bowl with reduced air pressure. Be sure all carbon deposits have been removed from throttle bore and idle discharge holes. Reverse the flow of compressed air through all passages to insure the removal of all dirt. **NEVER USE A DRILL OR WIRE TO CLEAN OUT JETS OR IDLE HOLES.**

INSPECTION OF PARTS

1. Float Assembly — Replace if loaded with gasoline, damaged or if float axle bearing is worn excessively. Inspect float lever for wear at point of contact with fuel valve needle. Replace if wear is excessive.
2. Float Axle — Replace if any wear has occurred on the bearing surface.
3. Fuel Valve (Needle & Seat) Assembly — Replace as a complete unit. Wear of any of these parts can seriously affect the operation of the float.
4. Idle Adjusting Needle — Inspect tapered end of the needle to make sure it is smooth and free of grooves. Replace if pitted or grooved.
5. Gaskets, Seal and Retainer — Replace all gaskets, throttle shaft seal and retainer each time the carburetor is overhauled.
6. Check Specifications. Verify the correctness of the following parts. Numbers will be found on the parts. Main Jet, Idling Jet and Fuel Valve.

REASSEMBLY

ASSEMBLY OF THROTTLE BODY

1. Install the fuel valve seat (31) and fibre washer (30), using Zenith Tool No. C161-85.
2. Install the main discharge jet (32), using a small screwdriver.
3. Install fuel valve needle in seat (31), followed by float (36) and float axle (35). **NOTE:** Insert tapered end of float axle (35) into float bracket on side opposite slot and push through the other side. Press float axle (35) into slotted side until the axle is centered in bracket.
4. **FLOAT SETTING**
 - a. **Fuel Level.** Check position of float assembly (36), for correct measurement to obtain proper fuel level by using a depth gage. **NOTE:** Do not bend, twist, or apply pressure on the float body.
 - b. With bowl cover assembly (26) in an inverted position, viewed from free end of float (36), the float body must be centered and at right angles to the machined surface. The float setting is measured from the machined surface (no gasket) of float bowl cover to top side of float body at highest point. This measurement should be $31/32"$, plus or minus $1/32"$.
 - c. **Bending Float Lever.** To increase or decrease distance between float body (36) and machined surface (26) use long nosed pliers and bend lever close to float body. **NOTE:** Replace with new float if position is off more than $1/16"$.
5. Install throttle body to fuel bowl assembly gasket (37) on machined surface of throttle body (26).
6. Install idle adjusting needle (17) and spring (18). Screw needle IN (clockwise) until it seats lightly against the idle discharge hole, then back it out $1\frac{1}{2}$ turns as a preliminary idle adjustment.

REASSEMBLE FUEL BOWL

1. Install the main jet (41) and fibre washer (40), using Zenith Tool No. C161-83 main jet wrench.
2. Install the main jet hex plug (43) and fibre washer (42), using a 9/16" open end wrench.
3. Install the idle jet (38), using a small screwdriver.
4. Install the bowl drain plug (44).

REASSEMBLE CARBURETOR BODIES

Install the three bowl assembly screws (45, 46) through the fuel bowl and into the throttle body and draw down firmly and evenly.

SPECIAL TOOLS

The special tools recommended are:

1. C161-83 Main Jet Wrench.
2. C161-85 Fuel Valve Seat Wrench.

Magneto Service Instructions

WISCONSIN No. Y-128-S1 – FAIRBANKS-MORSE Type FM-X4B7D
For Engine Models V-461D and V-465D

GENERAL DESCRIPTION

Fairbanks-Morse Type FM-X4B7D Magneto is designed and engineered to provide quick easy starting and maximum dependability of operation with minimum service. The compact alnico magnetic rotor assures an intensely hot spark under most operating conditions.

SERVICE PROCEDURE

The first step in magneto field servicing is to examine the magneto for corroded high tension towers, broken wires, or high tension wires not pushed far enough into the magneto tower to make good contact.

Then test the ignition spark while the engine is being cranked. Hold the ignition wire 1/4 in. away from the engine block. If a strong spark is observed, the magneto is not the cause of the engine malfunction. If no spark is seen, proceed with servicing the magneto.

SERVICING BREAKER POINTS

Remove the end cap cover, distributor rotor and the end cap. Then inspect the breaker points for pitting, oxidation and shorting. If points are worn or shorted, they should be replaced.

To remove the point set, take out the breaker arm terminal screw releasing the breaker arm spring, coil lead and condenser lead. Remove the fulcrum pin snap ring and slide the breaker arm off the fulcrum pin. Remove the contact support locking screws and lift off the contact support.

The installation of new points is the reverse of the removal. After the points have been installed, they should be adjusted to the correct clearance of *0.015 inch* at high point of cam. Be sure the points are clean and bright before adjusting them. Insert a screwdriver in the slot of the support bracket and pivot it between the two small bosses on the bearing support until the desired clearance is obtained. Then clean the points again before sealing the magneto.

FIELD SERVICE NOT RECOMMENDED

The cam wick, if dry or hard, should be replaced with a new factory impregnated wick. Other than this the Type FM-X4B7D Magneto does not require field lubrication. No attempt should be made to oil or grease the magneto bearings. The magneto lubricant should

be replaced only during the overhaul of the magneto by a Fairbanks-Morse authorized service station using recommended lubricant and factory engineered parts.

Coil and condenser replacement while simple are not recommended unless adequate test equipment is available. Under no circumstances should any attempt be made to remove the magnetic rotor from the housing unless specific instructions for releasing the shaft are available.

TIMING THE MAGNETO TO THE ENGINE

If the magneto has been removed from the engine for servicing, the operator must follow the engine manufacturer's instructions for timing the magneto to the engine. Refer to 'Magneto Timing' in engine instruction manual. When installing the magneto on the engine, be sure the magneto is properly attached and that the housing to engine gasket is in good condition.

SPECIAL DRIVE GEAR

The magneto is equipped with a special drive gear mounted directly on the impulse coupling. If it is necessary at any time to remove the drive gear, special care must be exercised in reassembly. It is possible to be off 180° in mounting the gear, with relation to the correct location of the timing mark on the gear.

Assemble gear as follows: Remove magneto end cap cover and turn distributor rotor until it is in firing position for No. 1 cylinder, as illustrated in *Fig. A*. Retain rotor in this position and fit the drive gear to the impulse coupling lugs so that the prick punch mark on front of gear is located as shown.

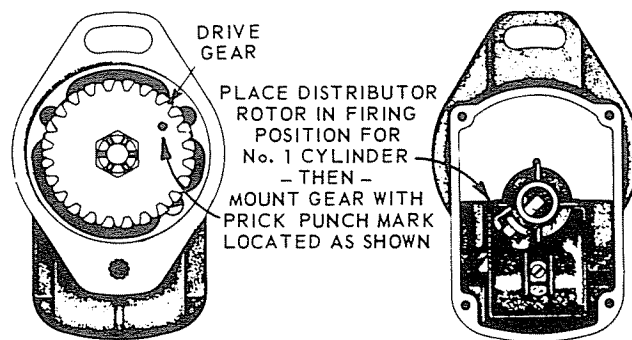

Fig. A, DRIVE GEAR MARKING AND ASSEMBLY

SOLID STATE IGNITION DISTRIBUTORS

Many new Wisconsin multi-cylinder engines are now being equipped with a solid state ignition distributor. Externally the new solid state ignition distributors are similar in appearance to a conventional point ignition distributor. Internally the major differences are:

1. Distributor cam which opens ignition points has been replaced with a magnet assembly.
2. Ignition points have been replaced with a "Hall effect type" electronic module.

This solid state ignition distributor uses two primary wire leads which attach to the ignition coil. The black or blue lead connects the negative (-) terminal of the ignition coil while the red lead connects to the positive (+) side of the ignition coil.

NOTE: The same Wisconsin coil is used on the solid state and point ignition systems.

TROUBLESHOOTING

The following steps should be performed if the engine's ignition system appears to be not operating properly:

1. Visually inspect plug wires, coil wire, distributor cap and rotor. Replace any components that show deterioration. It is especially important that the cap and plug wires be in good condition, free of oil, grease and moisture.
2. Check for loose or poor connections in ignition circuit. Check battery terminals for corrosion and loose connections.
3. Check battery voltage with engine off. It should be 12 to 15 volts.

If the above items have been checked and found to be proper and the engine's distributor is believed to be faulty, the distributor should be tested.

NOTE: Ignition timing adjustment specifications and procedures for the solid state ignition systems are the same as the corresponding point ignition distributor. An automotive type timing light should be used to check and adjust ignition timing.

TESTING

Testing can be done either with a voltmeter or a 12 volt test light.

VOLT METER TESTING

1. Connect the positive (+) lead of a voltmeter to the negative (-) side of the ignition coil. Ground the negative (-) lead of the voltmeter. Set the voltmeter to DC volts on at least a 15 volt scale.
2. Disconnect the high voltage wire from the center of the distributor cap and ground it to the engine block or chassis.
3. Crank engine.
4. The voltmeter should fluctuate from a range of 1 to 2 volts to a range of 10 to 12 volts as the engine is cranked.
NOTE: On some voltmeters the needle will appear to bounce between 1 and 12 volts.
5. If the voltmeter does not fluctuate, one of the following problems exist:

- a. If the voltmeter shows a constant 0 reading, there is an open circuit somewhere in the primary ignition circuit.
- b. If the voltmeter shows a constant voltage in the 1.0 to 3.5 volt range, the electronic module is shorted out.
- c. If the voltmeter shows a constant voltage equal to the battery voltage, the electronic module has an open circuit and requires replacement.

12 VOLT TEST LIGHT

1. Connect the test light between the positive (+) side of the ignition coil and ground. With the ignition switch in the "on" position the light should light.
NOTE: If there is no voltage present at the positive side of the coil, recheck the circuit from the battery through the ignition switch to the coil.
2. Disconnect the black primary lead going between the ignition coil negative (-) terminal and the distributor. Connect the test light to the negative (-) terminal of the ignition coil. Turn the ignition switch on - the test light should light, if not the ignition coil primary winding is open and the coil should be replaced.

Reconnect the black primary lead of the distributor to the negative (-) terminal of the ignition coil. Connect the test light again to the negative terminal of the ignition coil.

3. Disconnect the high voltage wire from the center of the distributor cap and ground to the engine.
4. Crank the engine.
5. The test light should flicker as the engine is cranked.
6. If the light does not flicker then the distributor electronic module is faulty.

NOTES

To avoid damage to the distributor components the following conditions must be avoided:

1. REVERSE POLARITY - **Do not** reverse the battery cables - (this distributor is for negative ground systems only) or the ignition coil wires. Black coil lead to negative terminal of the coil; red lead to positive terminal of the coil.

Some early production distributors have a blue lead instead of a black lead for the negative coil lead.

2. VOLTAGE SURGES - **Do not** operate the engine with the battery disconnected. Insure all electrical connections are made properly. Avoid using switches on the engine which cause excessive arcing.
3. Disconnect the ground (negative) cable when charging the battery.
4. JUMP STARTING - Only use another 12 volt battery for jump starting - be sure battery polarity is correct (positive to positive, negative to negative.)

NOTE: A HIGH AMPERAGE BOOST CHARGER CAN DAMAGE THE SOLID STATE COMPONENTS WITHIN THE DISTRIBUTOR.

SOLID STATE IGNITION DISTRIBUTORS

SERVICE PARTS LIST PER-LUX YF50S1/YF50AS1 DISTRIBUTOR

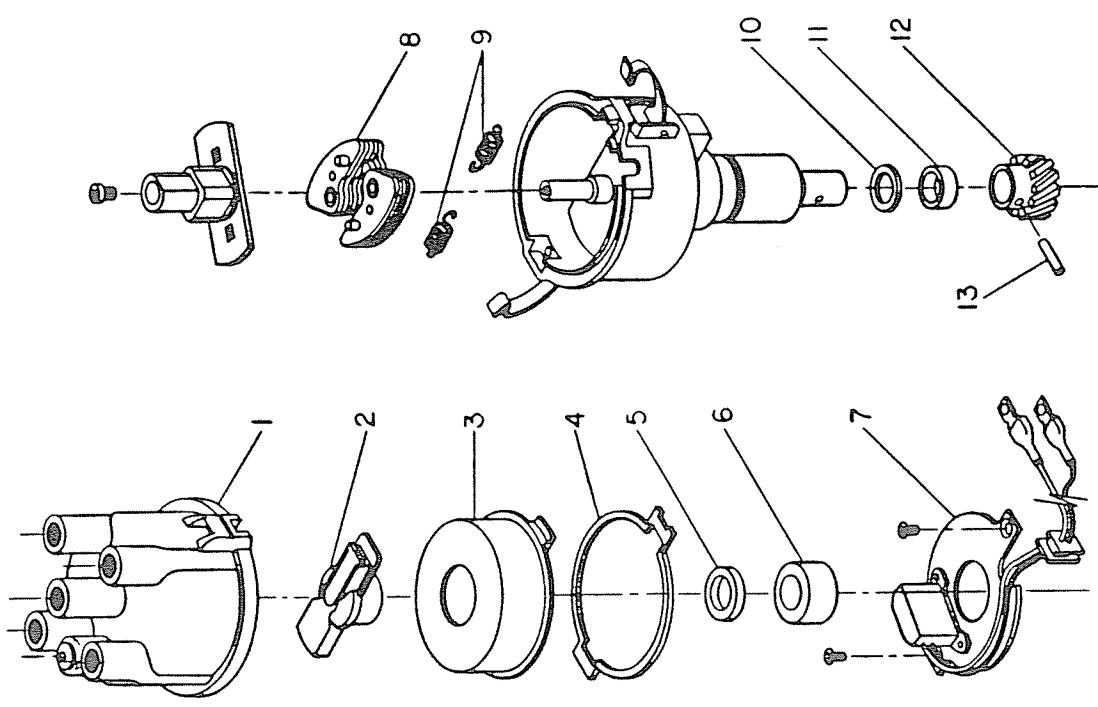

DISTRIBUTOR	APPLICATION	ITEM NO.	PART NO.	DESCRIPTION	QTY.
YF50S1	V465D				
--		20121003		DISTRIBUTOR CAP & GASKET (INCLUDES #1 & #4)	1
1			VENTED DISTRIBUTOR CAP	1
--		20121006		ROTOR AND SPACER (INCLUDES #2 & #5)	1
2			ROTOR	1
3		20120003		DUST COVER	1
*4		20120010		DISTRIBUTOR CAP GASKET	1
*5		20120011		ROTOR SPACER	1
6		20120004		MAGNET ASSEMBLY	1
7		20120005		ELECTRONIC MODULE (INCLUDES SCREWS)	1
8		20120015		ADVANCE WEIGHTS SET	1
9		20120012		ADVANCE SPRING SET	1
--		20121001		GEAR KIT (INCLUDES #10, #11, #12, #13)	1
10			THRUST WASHER SET (SELECT ONE)	1
11			SPACER (YF50AS1 ONLY)	1
12			GEAR	1
13			ROLL PIN	1
--		YL394-18		WIRE, EXTENSION (NOT SHOWN)	2

SHAFT END PLAY: .001" - .015"

* ALSO SOLD SEPARATELY

V
4
6
5
D

V
4
6
0
D

V
4
6
1
D

SERVICE AND PARTS
Available from your Authorized
WIS-CON TOTAL POWER
Service Center

 **WIS-CON**
TOTAL POWER CORP.

HEADQUARTERS:

3409 Democrat Road P.O. Box 181160 Memphis, Tennessee 38181
Phone: (901) 365-3600 TELEX: 462-1058 (ITT) FAX NO: (901) 369-4050

EUROPEAN:

Rue Joseph Deflandre, 13 B-4053 Chaudfontaine (Liege) Belgium
Phone: (32) (41) 675320 TELEX: 42631 TDY TP B FAX NO: (32) (41) 677987