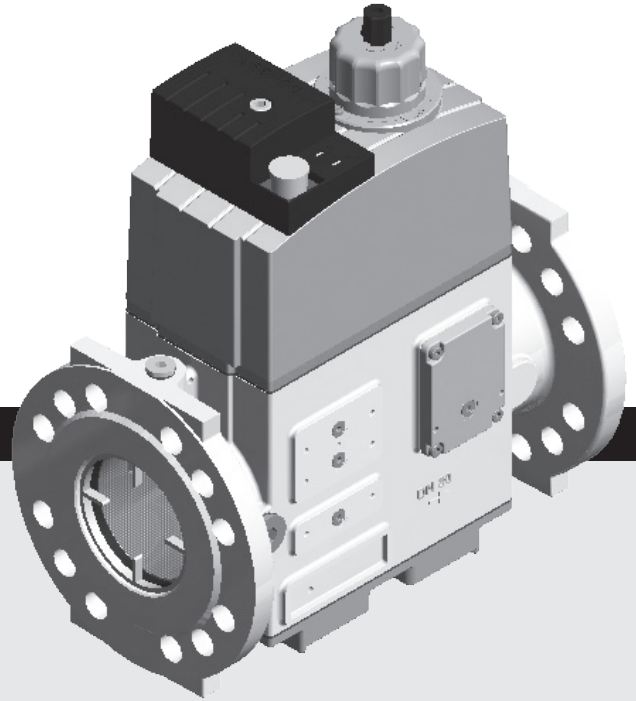

Table of Contents

Table of Contents Page 1
 Approvals Page 1
 Attention Page 1
 Specification Page 2
 Mounting Page 3
 Painting Valve Page 3
 Protection from Radiant Heat Page 3
 Wiring Page 4
 Valve Adjustment Page 4
 Proof of Closure Switch Page 5
 Side Taps Page 6
 Valve Leakage Test Page 7
 Flow Curve Page 8
 Pressure Drop for other Gases Page 8
 Accessories & Replacement Page 9



Approvals



CSA Certified
 ANSI Z21.21/CSA 6.5 C/I



FM Approved

EU Gas Appliance Directive
 MA State G1-0213-319
 AGA (Australian Gas)

Attention



The installation and maintenance of this product must be done under the supervision of an experienced and trained specialist. Never perform work if gas pressure or power is applied, or in the presence of an open flame.

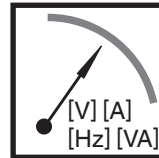

Check the ratings in the specifications to make sure that they are suitable for your application.



Please read the instruction before installing or operating. Keep the instruction in a safe place. You find the instruction also at www.dungs.com If these instructions are not heeded, the result may be personal injury or damage to property.



On completion of work on the safety valve, perform a leakage and function test.



Any adjustment and application-specific adjustment values must be made in accordance with the appliance-/boiler manufacturers instructions. Proof-Of-Closure switch can only be factory installed and set.



This product is intended for installations covered by, but not limited to, the following fuel gas codes and standards: NFPA 54, IFGC (International Fuel Gas Code), or CSA B149.1 (for Canada) or the following equipment codes and standards: CSD-1, NFPA 86, NFPA 37, ANSI Z83.4/CSA 3.7, ANSI Z83.18, ANSI Z21.13/CSA 4.9, CSA B149.3 (for Canada), or CSA B149.6 (for Canada).

Explanation of symbols

- 1, 2, 3 ... = Action
- = Instruction

Specification

DMV Two normally closed safety shutoff valves in one housing. V1 and V2 are fast opening, fast closing.

DMV-D Two normally closed safety shutoff valves in one housing. V1 and V2 are fast opening, fast closing. Adjustable max. flow on V1.

DMV-DLE Two normally closed safety shutoff valves in one housing. V1 fast opening, fast closing. V2 slow opening, fast closing valve. Adjustable max. flow V1 and adjustable initial lift with V2.

DMV-D(LE) /60x Does not include any Proof Of Closure

DMV-D(LE) /62x Includes Proof of Closure on V2

DMV-D(LE) /63x Includes Proof of Closure both on V1 and V2



Max. Operating Pressure

MOP = 7 PSI (500 mbar)
FM Pending, CE
MOP = 7 PSIG (500 mbar)

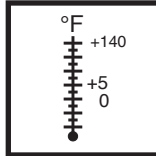

Ambient Temperature

+5 °F ... +140 °F
(-15 °C ... +60 °C) NBR Versions
+32 °F ... +140 °F
(0 °C ... +60 °C) Viton Versions



Electrical Ratings Available

110 - 120 VAC / 50 - 60 Hz
220 - 240 VAC / 50 - 60 Hz
24 VDC

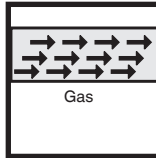

Gases

Dry, natural gas, propane, butane; other noncorrosive gases. Suitable for up to 0.1 % by volume, dry H₂S. A "dry" gas has a dew point lower than +15 °F and its relative humidity is less than 60 %.

Materials in contact with Gas

Housing: Aluminium, Steel, free of nonferrous metals. Sealings on valve seats: NBR-based rubber / FKM for the VITON version.

Power Consumption with all coils energized (24 VDC/120 VAC & 230 VAC)

	Inrush (VA)	Operation (VA)
DMV-D(LE) 5065/6xx eco	130 VA	32 VA
DMV-D(LE) 5080/6xx eco	190 VA	40 VA
DMV-D(LE) 5100/6xx eco	250 VA	50 VA
DMV-D(LE) 5125/6xx eco	250 VA	50 VA

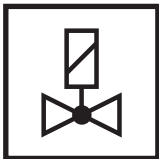

Max. Flow Setting (DMV-D & DMV-DLE)

Adjustable on V1:
Valve one: <5 to 35 % of total flow

Initial Lift Adjustment (DMV-DLE) only

Adjustable:
0 to 70 % of total flow; 0 to 35 % of stroke

Opening Time

DMV-D: V1 & V2 < 1 s
DMV-DLE: V1 < 1 s; V2 10 to 20 s

Closing Time

V1 & V2 < 1 s

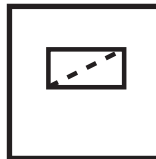

Strainer

23 Mesh, installed in the housing upstream V1

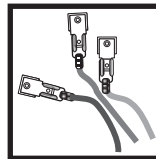

Electrical Connection

DIN-connector (Order No. 210319) required. M20 - 1/2 NPT Adapter (Order No. 240671) required for a conduit connection. Order parts separately. Wiring according to CSA C22.1 Part 1

Gas Connection

Flanged according to ISO 7005-1 or -2 (PN16), raised face

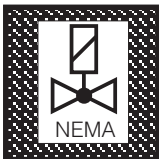

Enclosure Rating

IP 54 / NEMA Type 12
NEMA 4 OPTIONAL

/6x2 are IP 54 / NEMA 12
/6x4 are NEMA 4 / IP 65

Additionally Required Electrical Parts

Description	Order No.
DIN Connector	210319
Conduit Adapter	240671

Mounting

DMV 5... Flanged Mounting Procedure

1. Install the DMV 5.../Eco with the gas flow matching the direction indicated by the arrows on the casting.
2. Mount the DMV 5.../Eco with the solenoid vertical to horizontal.
3. Insert seal
4. Insert bolts, tighten in a star pattern to ensure uniform tightness.
5. Do not overtighten the bolts. Follow the maximum torque values listed.
6. After installation is complete, perform a leak test. (see "Valve Leakage Test")

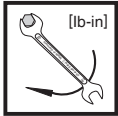

Recommended Torque System Accessories	M8
	134 lb-in

Installation position

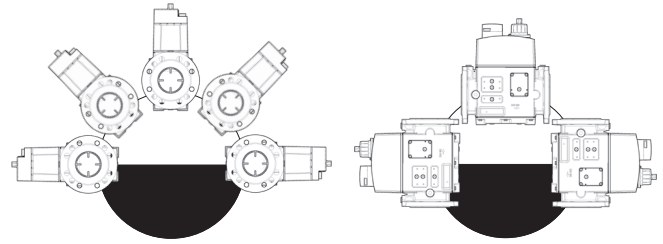

If the flow is not in the same direction of the arrows, the valves will not operate properly.

DMV 5... Flanged

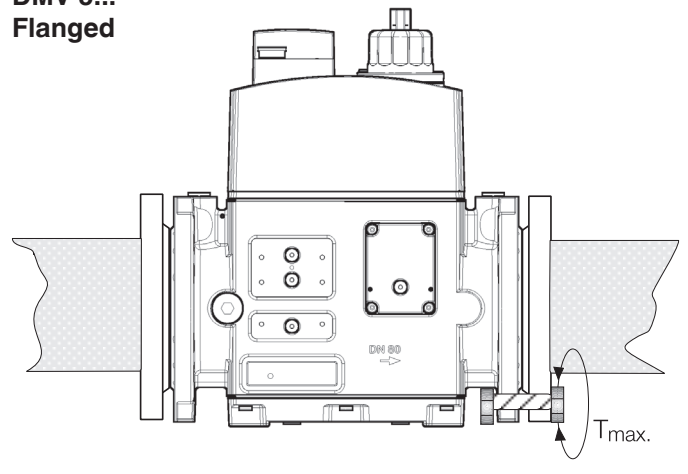

Recommended Torque for Bolts	Bolt	T _{max}
	M16 (DIN 939)	443 [lb-in]

Painting Valve

- It is not recommended that this valve be painted. Painting covers date codes and other labels that identify this valve.
- If the valve needs to be painted, a paint free of volatile organic components (VOC's) must be used. VOC's can damage valve o-rings, resulting in external gas leakage over time.
- During the painting process, use measures that will allow the valve's date code and other labeling information to be legible after the paint is dry

Protection from Radiant Heat

- Radiant heat must be considered as a heat source that could result in an ambient temperature higher than the rating of this valve.
- Provide proper shielding to protect against radiant heat.

Wiring

- Disconnect all power to the valves before wiring to prevent electrical shock and equipment damage.
- Do not exceed the electrical ratings given in the specifications and on the valve.
- Attach a flexible 1/2" NPT conduit to the DIN connector.
- Route the wires through the conduit and the DIN connector.
- Use 14 or 16 gauge wire for at least 75 °C (167 °F).
- Connect the wiring to the appropriate screw terminals in the DIN connector.
- Plug the DIN connector into the AMP terminals on the valve. Fasten the DIN connector with the screw supplied.

⚠ Label all wires prior to disconnection when servicing valves. Wiring errors can cause improper and dangerous operation. Verify proper operation after servicing.

⚠ All wiring must comply with local electrical codes, ordinances and regulations.

DIN Connector screw terminal connections

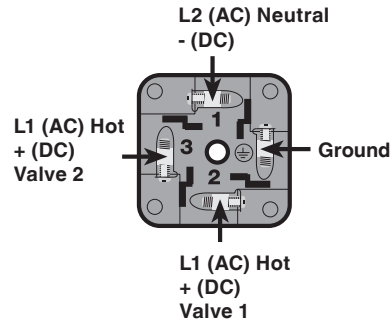

Valve Adjustment

Flow Setting (Only on -D and DLE Versions)

1. The valve is factory set with the flow adjustment fully open.
2. Locate the flow adjustment on top of valve 2. There are two screws, the holding screw is recessed and has a blue sealing compound on it, while the pan head screw protrudes from the cap. Loosen the pan head screw until you can freely rotate the flow adjustment. Turn clockwise for less gas or counterclockwise for more gas. Check the flow at the burner with an orifice or flow meter.
3. Tighten the pan head screw on the adjustment cap.

Initial Lift Adjustment (DMV-DLE only)

The initial lift adjustment varies the initial gas flow through the valves as the valve seat begins to open. This adjustment can vary the initial flow between 0 % and 70 % of the total gas flow; 0 to 35 % of stroke. All DMV-DLE valves are factory set with no initial lift. To adjust the lift proceed as follows:

4. Unscrew the small black cap on top of the silver hydraulic brake to expose the initial lift adjustment knob.
5. The black cap also serves as tool, turn the cap over and insert it on the slot on the adjustment knob.
6. Turn the knob clockwise for a min. initial lift or counterclockwise for a max. initial lift.
7. Once the desired initial fast lift has been achieved, reinstall the black cap.

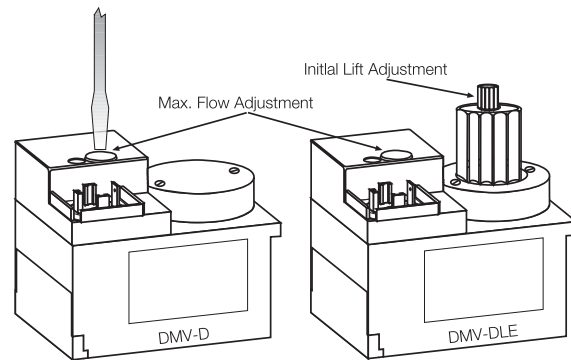

Initial Lift Opening Curve

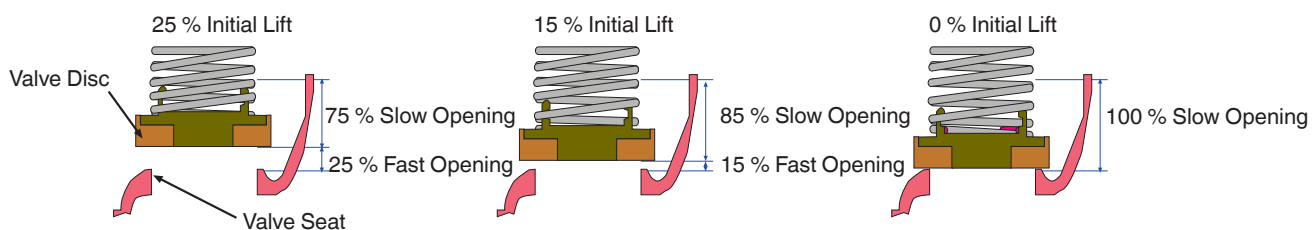
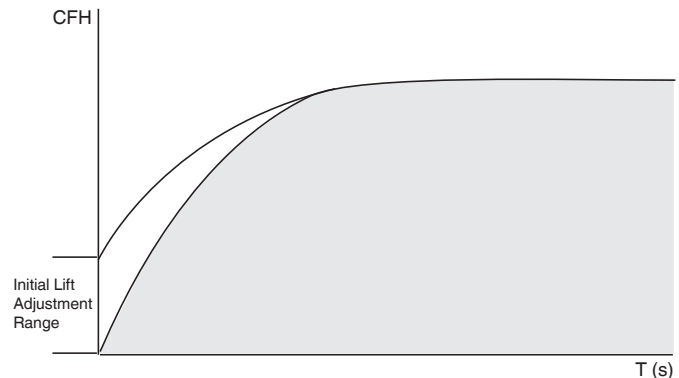

Proof of Closure Switch

Location

The proof of closure switch is factory installed on valve 2 of the DMV, it visually and electrically indicates valve position. When the valve is closed (NO position) an orange light is visible, when the valve is open (NC position) a green light is visible.

Conduit Connection

- Before connecting conduit to the proof of closure switch, position the proof of closure switch so that there is no torque from the wiring or conduit. If the switch needs to be rotated, loosen the slotted set screw on the side. The switch may be removed from the brass adapter for wiring, however, DO NOT turn the proof of closure switch after tightening the slotted set screw.
- Tighten the slotted set screw so that the proof of closure switch housing is secure. (16 lb-in torque)

Wiring

- Do not exceed the electrical ratings given in the proof of closure switch specifications.
- Use 14 or 16 gauge wire for at least 75 °C (167 °F).
- Connect wire to the appropriate terminal of the proof of closure switch (see the wiring diagram). COM to the L1, Ground to ground, NO to the Proof of Closure terminal of the Flame Safeguard and N to L2. The ORANGE light shall be on when the valve is closed, the GREEN light shall be on when the valve is open (FM requirement).

Annual Testing

- Perform a switch continuity test at least annually to verify that the proof of closure switch is working properly.
- Make sure that there is no power to the proof of closure switch.
- Shut the upstream ball valve to stop the flow of gas into the valve train.
- With the valve de-energized, use a multimeter and verify that there is continuity between the switch contacts 3 (COM) and 2 (NO). Then verify that there is no continuity between the switch contacts 3 (COM) and 1 (NC).
- Energize the valve that the proof of closure switch is mounted to. Use a multimeter and verify that there is continuity between the switch contacts 3 (COM) and 1 (NC). Then verify that there is no continuity between the switch-contacts 3 (COM) and 2 (NO).
- If you experience a problem, contact DUNGS
- De-energize the valve and replace the cover on the proof of closure switch
- Open the upstream ball valve

Proof of Closure Switch Specifications

Switch

SPDT

Switch Action

Valve open: Switch in NC position, Green light on.

Valve closed: Switch in NO position, Orange light on.

Contact Rating

10 A res, 8 FLA, CSA (5A res., 2 A ind.) 48 LRA @120 VAC

Enclosure

NEMA Type 4

Ambient/Fluid Temperature

-40 °F to 150 °F

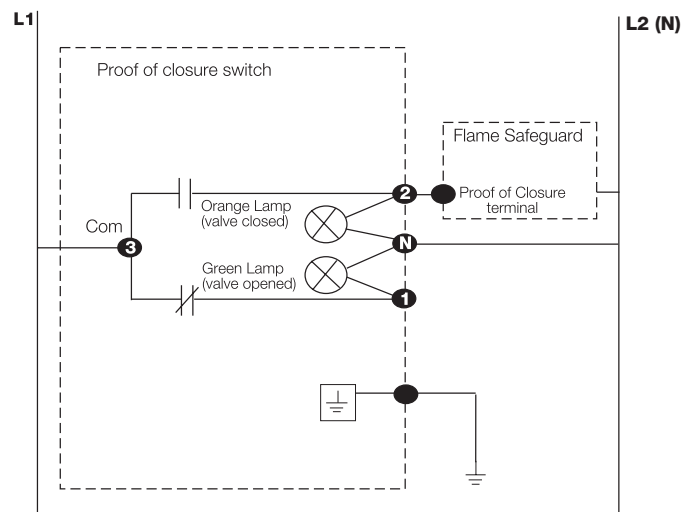
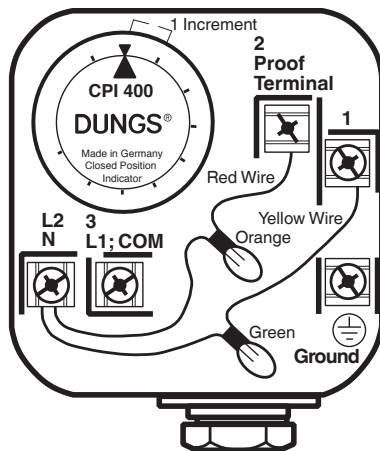

⚠ Do not wire the valve switch to close a circuit that will directly power another safety shutoff valve. Doing so could result in a safety valve being energized and opened rather than remaining closed.

Side Taps

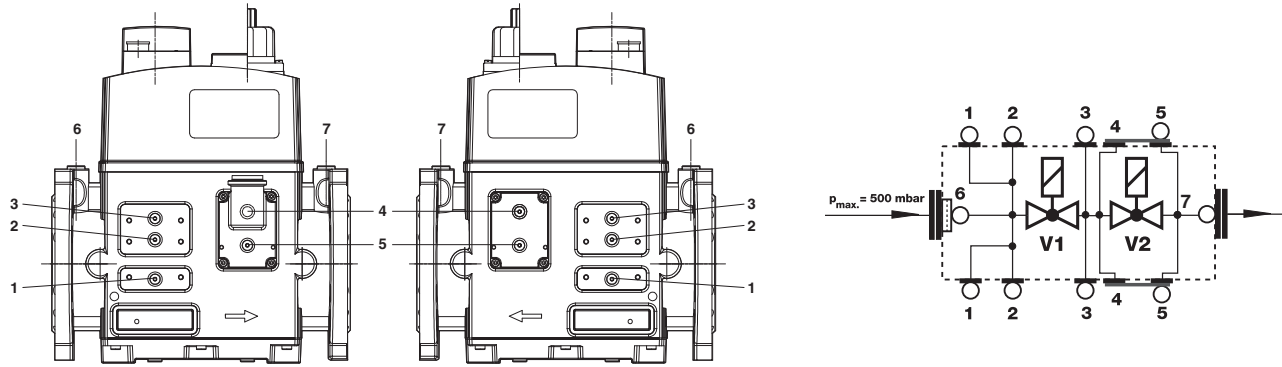

Side Taps

The G 1/8 ISO 228 taps are available on both sides upstream V1 (1, 2), between V1 and V2 (3, 4), downstream V2 (5). The G 1/8 test nipple (P/N 219008) can be screwed in any of these pressure tap ports. A G1/4" connection available on top of each flange (6 and 7).

Required Weld Neck Flanges for DMV 5... Series

Body Size	Flange Description	# of Holes per Flange	Flange Order No.	Bolt size	**Bolt Order No.	***Gasket Order No.
DMV-D(LE) 5065	2 1/2" ISO Flanged	4	227139	M16x65	135930	267465
DMV-D(LE) 5065	2 1/2" ISO to NPT	4	243690	M16x65	135930	267465
DMV-D(LE) 5080	3" ISO Flanged	8	227140	M16x65	135930	267466
DMV-D(LE) 5080	3" ISO to NPT	8	243219	M16x65	135930	267466
DMV-D(LE) 5100	4" ISO Flanged	8	227141	M16x65	135930	267467
DMV-D(LE) 5125	5" ISO Flanged	8	227142	M16x75	148830	267468

*When a control is used alone, one mating flange is needed for each end, for a total of two flanges.

When one control is bolted to another, such as an FRS to a DMV, one mating flange is needed for each end, for a total of two flanges.

**includes one stud, 2 washers and 2 nuts.

***one gasket needed for each flange connection.

Valve Leakage Test

This leak test procedure tests the external sealing and valve seat sealing capabilities of the DMV automatic safety shutoff valve. Only qualified personnel should perform this test.

It is required that this test be done on the initial system startup, and then repeated at least annually. Possibly more often depending on the application, environmental parameters, and the requirements of the authority having jurisdiction.

Setup

This test requires the following:

- Test nipples installed in the downstream pressure tap port of each automatic safety shutoff valve to make the required 1/4" hose connection in step 4.
- A transparent glass of water filled at least 1 inch from the bottom.
- A proper leak test tube. An aluminum or copper 1/4" rigid tube with a 45° cut at the end that is then connected to a 1/4" flexible hose of some convenient length provides for a more accurate leakage measurement. However, a 45° cut at the end of the 1/4" flexible hose will suffice, but it will not likely be as accurate as the rigid tube.
- For detecting external leakages, an all purpose liquid leak detector solution is required.

Leak Test Procedure

Use the illustration below as a reference.

- With the upstream ball valve open, the downstream ball valve closed and both valves energized, apply an all purpose liquid leak detector solution to the "External Leakage Test Areas" indicated in the illustration below, to any accessories mounted to the safety valve, and to all gas piping and gas components downstream the equipment isolation valve, and the inlet and outlet gas piping of the automatic safety shutoff valve. The presence of bubbles

indicates a leak, which needs to be rectified before proceeding.

- Then, de-energize the burner system and verify that both automatic safety shutoff valves are closed.
- Close the upstream and downstream manual ball valve.
- Using a screwdriver, slowly open the V1 test nipple (port 3 or port 4) by turning it counter clockwise to depressurize the volume between the two valves, and connect the 1/4" flexible hose to the test nipple.
- Slowly open the upstream manual ball valve, and then provide for some time to allow potential leakage to charge the test chamber before measuring the valve seat leakage.
- Immerse the 1/4 in. tube vertically 1/2 in. (12.7 mm) below the water surface. If bubbles emerge from the 1/4" tube and after the leakage rate has stabilized, count the number of bubbles appearing during a 10 second period. (See chart below for allowable leakage rates.)
- Repeat the same procedure for valve V2 (port 5), except that valve #1 needs to be opened. (Energize only terminal 2 on the DIN connector to open valve 1).

After completing the above tests proceed as follows:

- Verify that the downstream manual ball valve is closed, and both automatic safety shutoff valves are de-energized.
- Remove the flexible hose, and close all test nipples.
- With the upstream manual ball valve open, energize both automatic safety shutoff valves.
- Use soapy water to leak test all test nipples to ensure that there are no leaks.
- If no leakage is detected, de-energize all automatic safety shutoff valves, and open the downstream manual ball valve.



If leakage values are exceeded, replace valve immediately.

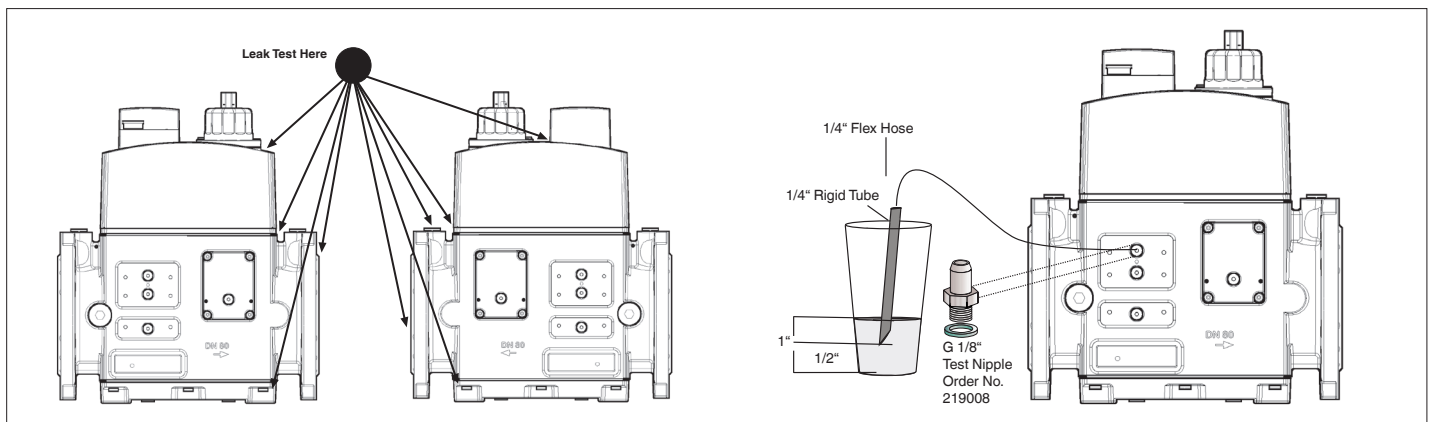

Type	Allowable Valve Seat Leakage* up to 7 PSI inlet	# of Bubbles in 10 s		
		Air	Natural Gas	LP
DMV-D(LE) 5065	633 cc/hr	11	13	10
DMV-D(LE) 5080	790 cc/hr	13	17	11
DMV-D(LE) 5100	934 cc/hr	17	22	15
DMV-D(LE) 5125	1156 cc/hr	22	27	18

*Based on air and test conditions per UL 429 Section 29. (Air or inert gas at a pressure of 1/4 psig and also at a pressure of one and one-half times maximum operating pressure differential, but not less than 1/2 psig. This test shall be applied with the valve installed in its intended position.) Volume of bubble defined in Table 2 of FCI 70-2-1998.

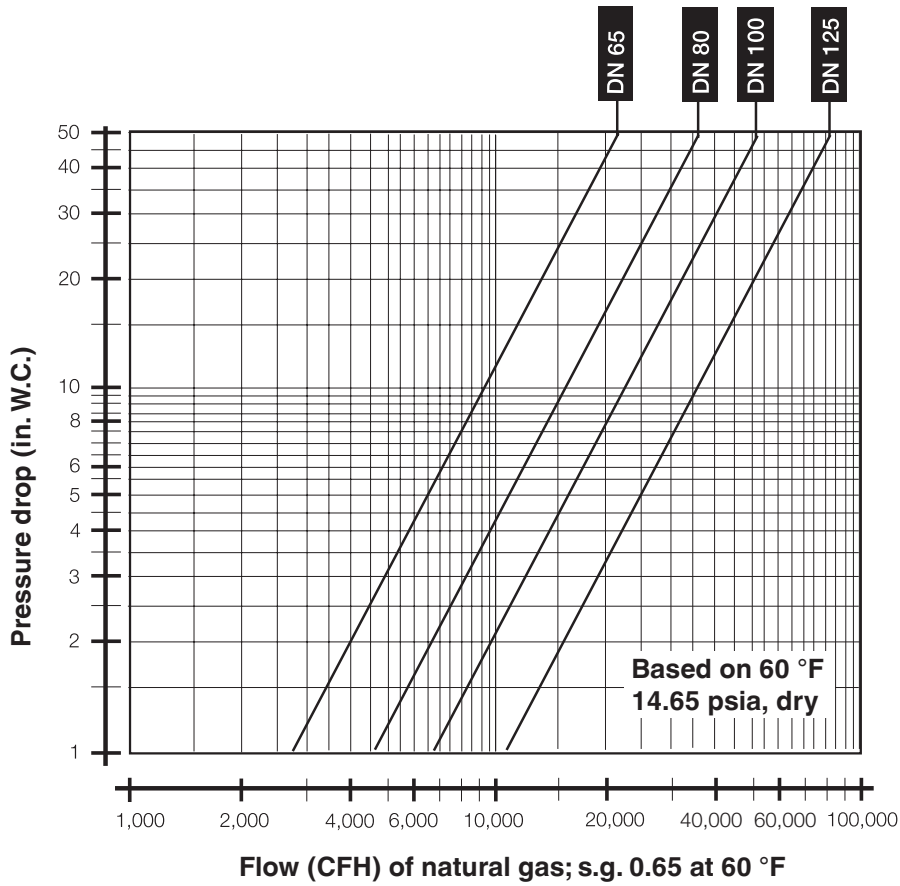

Pressure Drop for other Gases

To determine the pressure drop when using a gas other than natural gas, use the flow formula below and f value located in the table below to determine the “corrected” flow rate in CFH through the valve for the other gas used. For example,

when using propane, divide the volume (CFH) of propane required for the application by the calculated value f (f = 0.66 for propane). Use this “corrected” flow rate and the flow curve on the next page to determine pressure drop for propane.

Determining equivalent flow through valves using another gas

$$\dot{V}_{\text{gas used}} = \dot{V}_{\text{Natural gas}} \times f$$

$$f = \sqrt{\frac{\text{Density of Natural gas}}{\text{Density of gas used}}}$$

Type of gas	Density [kg/m ³]	s.g.	f
Natural gas	0.81	0.65	1.00
Butane	2.39	1.95	0.58
Propane	1.86	1.50	0.66
Air	1.24	1.00	0.80

Accessories & Replacement

Coil for	Coil Type	Order No. for 24 VDC	Order No. for 120 VAC	Order No. for 230 VAC
DMV 5065... eco	1411/2P	256633	255478	255477
DMV-D 5065... eco	1411/2P	NA	256630	256629
DMV-DLE 5065... eco	1411/2PL	NA	256632	256631
DMV-(D) 5080... eco	1511/2P	248503	253713	247869
DMV-DLE 5080... eco	1511/2PL	NA	262826	248496
DMV-(D) 5100... eco	1611/2P	248504	253677	247870
DMV-DLE 5100... eco	1611/2PL	NA	262825	248498
DMV-(D) 5125... eco	1711/2P	248505	253676	247871
DMV-DLE 5125... eco	1711/2PL	NA	262824	248500
Printed Wiring Board	Coil Type	Order No. for 24 VDC	Order No. for 120 VAC	
DMV 5065 eco	1411/2P	NA	NA	NA
DMV-D 5065 eco	1411/2P	NA	NA	NA
DMV-DLE 5065 eco	1411/2PL	NA	NA	NA
DMV-(D) 5080 eco	1511/2P	257604	257137	248492
DMV-DLE 5080 eco	1511/2PL	NA	262827	248493
DMV-D 5100 eco	1611/2P	257604	257137	248492
DMV-DLE 5100 eco	1611/2PL	NA	262827	248493
DMV-(D) 5125 eco	1711/2P	257604	257137	248492
DMV-DLE 5125 eco	1711/2PL	NA	262827	248493
Hydraulic Brake	Order No.			
DMV-DLE 5065	223158			
DMV-DLE 5080	223158			
DMV-DLE 5100	223157			
DMV-DLE 5125	223157			
Accessories/Adapter	Order No.	Description		
Electrical DIN Connector	210319			
Flat cover for ports 4 and 5	219005			
M20 - 1/2 NPT Adapter	240671			
Visual Indicator	266949	The indicator mounts to the bottom of the valve and visually displays when the valve is open or closed.		
Valve Switch CPI 400 (120 VAC)	266968	Brass Plunger with visual indication.		
Valve Switch CPI 400 (24 VDC)	273450	Brass Plunger with visual indication and 24V lights		
Valve Switch CPI 400	274058	Stainless Steel plunger with visual indication		
Vent Line Adapter - 1" NPT	243760	Field mountable		
G 1/8" test nipple with gasket	219008			

We reserve the right to make any changes in the interest of technical progress.

Karl Dungs, Inc.
3890 Pheasant Ridge Drive NE
Suite 150
Blaine, MN 55449, U.S.A.
Phone 763 582-1700
Fax 763 582-1799
e-mail info@karldungsusa.com
Internet http://www.dungs.com/usa/

Karl Dungs GmbH & Co. KG
P.O. Box 12 29
D-73602 Schorndorf, Germany
Phone +49 (0)7181-804-0
Fax +49 (0)7181-804-166
e-mail info@dungs.com
Internet http://www.dungs.com