



3.5kW, 5.0kW Auxiliary Power Units Operation and Maintenance Manual

Effective: October, 2000

3.5kW, 5.0kW Auxiliary Power Units

Overview: The purpose of the AlphaGen 3.5kW and 5.0kW Auxiliary Power Unit Operation and Maintenance Manual is to detail system operation and maintenance procedures.

Audience: This manual is intended for the system operators.

About this Manual:

Contents: This Operation and Maintenance Manual is comprised of four sections.

Section 1 System Overview. This section describes the AlphaGen 3.5kW and 5.0kW Auxiliary Power Unit (APU).

Section 2 Turn Up and Test. This section describes the preparing of the system and placing it into service.

Section 3 Maintenance. This section describes various maintenance procedures.

Section 4 Interconnections. This section details the connections between the APU, ECM, and the rest of the system.

Warranty

Alpha Technologies, Inc. provides a LIMITED WARRANTY covering the performance of its products. The terms and conditions of the LIMITED WARRANTY STATEMENT are contained in a separate written LIMITED WARRANTY STATEMENT included with the Operator's manual provided with this product. If there are any warranty claims, the purchaser (or the purchaser's representative) must follow the LIMITED WARRANTY guidelines, described in the applicable LIMITED WARRANTY STATEMENT.

NOTE: Various types of APUs may be installed in the system (or the manufacturer of this equipment may change the design of the alternator); therefore, the photographs used in this section are for reference only and may not exactly match the installed unit. Always refer to the engine manufacturer's Owner's manual, supplied with the enclosure, for proper location of the items specified in this procedure when performing adjustments or maintenance on the APU.

Alpha Technologies products are subject to change through continual improvement processes; therefore, specifications and/or design layouts may vary slightly from descriptions included in this manual. Updates to the manual will be issued when changes affect form fit or function.

Table of Contents

Section 1, System Overview

1.1 System Enclosure Overview	13
1.2 Specifications	15
1.3 APU Overview	16
1.4 Engine Control Module Overview	17
1.5 Generator Modes of Operation	19
1.5.1 Normal Operating Condition	19
1.5.2 Standby Operating Condition (less than 3 minutes)	19
1.5.3 Standby Operating Condition (more than 3 minutes)	19
1.5.4 Normal APU Shutdown	20
1.5.5 Abnormal APU Shutdown	20
1.5.6 ECM Operating Mode Summary	21
1.6 Operator's Interface Overview	22
1.7 ECM Alarm Overview	24
1.8 Propane Enclosure Overview	25

Section 2, Turn-Up and Test

2.1 Appearance and condition of components	27
2.2 Initial Operation	27
2.2.1 Ignition Battery Test Procedure	27
2.2.2 Engine Lubrication	28
2.2.3 Starting a Local APU Test	28
2.3 Generator System Sensor Verification	30
2.3.1 Enclosure Alarm Verification	30
2.3.2 AC and DC line Sense Verification	31

Section 3, Maintenance

3.1 Cleaning and Lubrication	32
3.2 Scheduled Maintenance	33
3.2.1 Maintenance Intervals	33
3.2.2 ECM Service Required Notification	34
3.2.3 ECM Self-Test Features	34
3.3 Servicing the APU	36
3.4 Filter Cleaning	37
3.5 PAD SHEAR Magnetic Switch and Water Intrusion Float	38
3.6 Replacing GAS HAZARD Sensor	40
3.7 Replacing Ignition Battery Charger Module Assembly	42
3.8 Replacing Engine Control Module	43
3.9 Replacing Flexible Gas Hose	44
3.10 Fuel Conversion - Natural Gas to Liquid Propane	45
3.10.1 Pre-regulator/Low Fuel Pressure Switch Replacement	45
3.11 Fan Replacement Procedure	48
3.12 Muffler Replacement Procedure	49
3.13 Muffler Exhaust Flange Gasket Replacement Procedure	51

ALPHAGEN™ Telecom Series

Table of Contents

Section 3, Maintenance

3.14	Gas Solenoid Replacement Procedure	52
3.15	Replacing Cabinet Exhaust Duct Upper Seal	53
3.16	Removal and Replacement of Generator Set	54
3.17	Maxitrol Pre-Regulator Calibration	57

Section 4, Interconnection

4.1	Alarm Sensor States	61
4.2	ECM Interface Topology and Connectors	62
4.3	Connectors	63
4.3.1	Gas Hazard Alarm Interface	63
4.3.2	Low Fuel Pressure Interface Connector	64
4.3.3	Solenoid	65
4.3.4	Charger Module – Control Interface Connector	66
4.3.5	Charger Module - Output Interface Connector	67
4.3.6	APU Ignition Battery Interface Connector	68
4.3.7	Alarm Control Interface to APU Interface Connector (APU-I/O)	69
4.3.8	ECM PWR-GRI Interface	70
4.3.9	ECM-PWR GRI Enclosure Sensor Interface Ribbon Cable	71
4.3.10	ECM and PWR-GRI Interface Ribbon Cable	72
4.3.11	Analog and Logic Power Interface Ribbon Cable	73
4.3.12	ECM - Enclosure Alarm Interface	74
4.3.13	DC Bus Sense Interface Connector	75
4.3.14	Charger Control Interface Connector	76
4.3.15	ECM - APU Control Interface	77
4.3.16	ECM - AC Sense 120/240V Interface	78
4.3.17	ECM - Alarm Interface & Communications	79
4.3.18	ECM Parallel Transponder Interface	80

ALPHAGEN™ Telecom Series

List of Figures

Fig.1-1, CE-3X2 Telecom Series Enclosure	13
Fig. 1-2 Cabinet Component layout	14
Fig. 1-3 System Block Diagram	16
Fig. 1-4 Location of Engine Control Module within the Engine-Generator Cabinet.	18
Fig. 1-5 Front view, Engine Control Module (ECM)	18
Fig. 1-6 Detail of Run-Auto-Stop (RAS) switch	23
Fig. 1-7 Overhead view, airflow patterns	25
Fig.1-8 Airflow patterns, CE-X Enclosure	26
Fig. 1-9 Airflow patterns, CE-G Enclosure	26
Fig. 2-1 Location of APU Control Board	28
Fig.2-2 Generator set master switch	29
Fig. 2-3 Location of ECM Run/Auto/Stop switch	29
Fig. 3-1 APU compartment	32
Fig. 3-2 APU housing door fasteners and control cables	36
Fig. 3-3 Access Panel and Air Filter	37
Fig. 3-4 Air Filter Removal	37
Fig. 3-5 Primary Regulator Gas Pressure Adjustment	57
Fig. 3-6 Regulator Calibration Component Arrangement	58
Fig. 3-7 Secondary Regulator Component Location	58
Fig. 4-1 ECM/APU Interconnection	62
Fig. 4-2 Gas Hazard Detector Interface	63
Fig. 4-3 Low Fuel Pressure Switch Interface	64
Fig. 4-4 Gas Solenoid Interface Connector	65
Fig. 4-5 Charger Control Interface	66
Fig. 4-6 Charger Output Interface	67
Fig. 4-7 APU Ignition Battery Connector	68
Fig. 4-8 Alarm Control Interface Connector	69
Fig.4-9 ECM Printed Circuit Boards	70
Fig.4-10 ECM-PWR GRI Enclosure Sensor Interface Ribbon Cable	71
Fig.4-11 ECM and PWR-GRI Interface Ribbon Cable	72
Fig.4-12 Analog/Logic Power Interface connection	73
Fig.4-13 Enclosure Alarm Interface	74
Fig.4-14 DC Bus Sense	75
Fig.4-15 Charger Control Interface Connector	76
Fig.4-16 Simplified block diagram, Charger Control Interface Connector	76
Fig.4-17 APU Control Interface	77
Fig.4-18 AC Sense, 120/240V Interface	78
Fig.4-19 RS-485 Communications Input Connector	79
Fig.4-20 Transponder Interface Connector	79

List of Tables

Table 1-1 Normal Mode Crank Cycle	20
Table 1-2 Major, Minor Alarm Indications, and Notifications	24
Table 3-1 Scheduled Maintenance	33
Table 4-2 ECM parallel Transponder interface	80

IMPORTANT SAFETY INSTRUCTIONS CONTAINED IN THIS MANUAL



To reduce the risk of electrical shock, injury or death caused by explosion of fuel or moving parts, and to ensure the safe operation of this unit, the following symbols have been placed throughout the manual. Where these symbols appear, servicing should be performed only by qualified personnel.



DANGEROUS VOLTAGE

This symbol indicates a “dangerous voltage” exists in this area of the product. Use caution whenever working in the area to prevent electrical shock.



INHALATION HAZARD - DON'T BREATHE VAPORS

This symbol indicates an “inhalation hazard” exists in this area of the product. Use caution whenever working in the area to prevent possible inhalation of harmful (fuel or exhaust) vapors.



NO MATCHES OR OPEN FLAMES

This symbol indicates a fire or explosive hazard exists in this area of the product. Use caution whenever working in the area to prevent possible combustion fuel vapors.



MECHANICAL OR MOVING PARTS HAZARD

These symbols indicate the presence of a “mechanical or moving parts hazard” in this area of the product. Use caution whenever working in the area to prevent possible injury to the operator or service personnel.

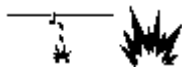

LEAK HAZARD

This symbol indicates a “leak hazard” exists in this area of the product. Use caution whenever working in the area to prevent and correct any leaks detected.



HOT SURFACES

This symbol indicates the presence of high temperatures which result from the operation of the system. To prevent burns, do not touch these areas while the system is in operation or immediately after it has been turned off.



ATTENTION

This symbol indicates important installation, operation or maintenance instructions. Always follow these instructions closely.

SAFETY PRECAUTIONS



NOTE: Failure to follow these precautions could result in injury or death caused by the explosion of fuel, moving parts hazards or electrocution.



CAUTION: This set of procedures will require the operation of the generator and should only be performed by qualified, experienced personnel in a well-ventilated area.

- Technicians must have easy access to a fire extinguisher at all times.
- Propane/Natural Gases are highly explosive. Use extreme caution while handling and operating the Generator gas package and equipment. Keep flame or spark away from Propane bottles. Do not smoke during assembly of gas package.
- Any test equipment used in the testing of the CE Series system must have isolated inputs to prevent shock hazards and short circuits with the enclosure or other grounded objects.
- Run Generator only in properly ventilated areas. Exhaust gasses can be lethal. Prolonged exposure can cause nausea, headaches, dizziness, or Carbon Monoxide poisoning.
- All pipe connections must be leak tested immediately.
- Output of upper air dam must be unobstructed.
- "Test" Propane bottles **MUST** not come into contact with the cabinet(s). Use a Digital Voltmeter (DVM) to ensure proper cabinet grounding.
- "Test" Propane bottles must remain upright at all times.
- All generator grid screens, covers, and access panels on the generator must be closed before operation. Moving parts are a hazard.
- Both generator compartment fans must be operational any time gas pressure is applied.

SAFETY PRECAUTIONS

- The system must be serviced only by qualified personnel.
- Remove all rings, watches and other jewelry before servicing batteries or servicing the system.
- Verify the voltage requirements of the equipment to be protected (load), the AC input voltage to the power supply (line), and the output voltage of the system prior to installation.
- The utility service panel must be equipped with a properly rated circuit breaker for use with this power supply.
- When connecting the load, DO NOT exceed the output rating of the system.
- Always use proper lifting techniques whenever handling units, modules or batteries.
- If batteries are being stored prior to installation, they should be charged at least once every three months to ensure optimum performance and maximum battery service life.
- The battery pack, used to provide backup power, contains dangerous voltages. Battery inspection and replacement must be performed by qualified personnel.
- Always wear protective clothing, insulated gloves and eye protection (i.e. safety glasses or a face shield) whenever working with batteries.
- Always carry a supply of water, such as a water jug, to wash the eyes or skin in the event of exposure to battery electrolyte.
- Do not allow live battery wires to contact the enclosure chassis. Shorting battery wires can result in a fire or possible explosion.
- Batteries must be inspected every three to six months for signs of cracking, leaking or swelling.
- Always replace batteries with those of an identical type and rating. Never install old or untested batteries.
- Avoid using uninsulated tools or other conductive materials when handling batteries or working inside the enclosure.
- Spent or damaged batteries are considered environmentally unsafe. Always recycle used batteries or dispose of in accordance with all Federal, State, and local regulations.

IMPORTANT INSTALLATION NOTES

The system must be installed **ONLY** by qualified service personnel.

Consult local utility codes for additional cabinet grounding and utility requirements.

In regions where the CE Mark is required, locate unshielded electronic and electrical equipment outside a 3-meter radius of the Alphagen.

ALPHA TECHNOLOGIES is not responsible for broken welds or other damage to the cabinet caused by improper installation.

All dimensions are given in inches.

For further information regarding this installation, contact ALPHA TECHNOLOGIES or your nearest ALPHA representative.

For general product information and Customer Service
7:00AM to 5:00PM Pacific Time
1-800-863-3930



To obtain complete Technical Support,
7:00AM to 5:00PM Pacific Time

or

For after-hours Emergency support
7 days per week, 24 hours a day

1-800-863-3364



NOTE: Alpha Technologies' products are subject to change through continual improvement processes. Therefore, specifications and/or design layouts may vary slightly from descriptions included in this manual. Updates to the manual will be issued when changes affect form, fit or function.

Save these instructions for future reference

Auxiliary Power Unit (APU) Notes



NOTE: When the engine is stopping, a small amount of unburned fuel may be detected by the odor of gas fumes. Fans are used to expel these fumes from the enclosure and may be detected outside the enclosure for a short period of time after engine shutdown. This is a normal condition and does not present a hazard.



NOTE: Most utilities add a chemical agent to the gas which produces a strong odor so leaks can be detected before they reach a dangerous or explosive level. It may be possible to detect this gas additive odor even though the gas hazard sensor does not issue an alarm. The gas sensor will issue an alarm when the detected levels of gas reaches 10% - 20% of the Lower Explosive Limit (LEL). The gas hazard sensor has a 10 minute delay for periods of purging and power up. During the purge phase, the Green alarm light will flash. When the purge phase is completed, the light will glow steadily. In the event the detector has been disconnected from power for more than 24 hours, it may require a period of more than 10 minutes to complete its purge phase. In that event, push the reset button to disable the alarm for repeated purge cycles. Also, the reset button may be used to disable the alarm for 10 minutes at any time.

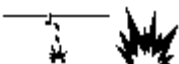

NOTE: If gas fumes are detected before the engine is run, or in excess of approximately 10 minutes after running the engine, you must check the system for leaks as described in the INSTALLATION manual and correct as necessary.

Battery Safety Notes

Chemical Hazards

Any gelled or liquid emissions from a Valve-Regulated Lead-Acid (VRLA) battery is electrolyte which contains dilute sulfuric acid which is harmful to the skin and eyes; is electrically conductive; and is corrosive. If electrolyte contacts the skin, wash immediately and thoroughly with water.

If electrolyte enters the eyes, wash thoroughly for 10 minutes with clean water or a special neutralizing eye wash solution and seek immediate medical attention. Neutralize any spilled electrolyte with the special solutions contained in a "spill kit" or with a solution of 1 lb. Bicarbonate of soda to 1 gal. of water.

Fire, Explosion, and Heat hazards

Lead acid batteries can contain an explosive mixture of hydrogen gas which can vent under overcharging conditions.

Do not smoke or introduce sparks in the vicinity of the battery.

Prior to handling the batteries, touch a grounded metal object, such as the rack, to dissipate any static charge that may have developed in your body.

Do not charge batteries in a sealed container. The individual batteries should have 0.5 inches of space between them to allow for convection cooling. If contained, assure the container or cabinet and room have adequate ventilation to prevent an accumulation of potentially dangerous gas.

1.1 System Enclosure Overview

This manual is intended to provide a general functional overview for the Auxiliary Power Unit (APU) used with the CEX2 Telecom Series Enclosures and also covers basic APU Operation and Maintenance. For more detailed information pertaining to the installed APU, please consult the Generator Manufacturer's Owner's Manual.

The APU is housed in a sound-attenuated, enclosed compartment which contains inlet and exhaust vents. Cooling air enters the APU via the inlet vents on the rear cabinet door. Additionally, the APU and main enclosures are equipped with fans which, when the engine is off, force air into the APU compartment as well as the main enclosure to direct any remaining gas fumes out of the enclosure via the exhaust vent. During engine operation, an integral engine-mounted fan provides cooling air in the same manner as previously mentioned.



Fig.1-1, CE-3X2 Telecom Series Enclosure

1. System Overview

1.1 System Enclosure Overview, *continued*

System components shown below allow for easy access during operation and maintenance. The 12 Volt ignition battery for the APU is housed in an electronics compartment above the APU. All operations of the APU are controlled automatically by the Engine Control Module (ECM). Operator intervention is not required to start or stop the APU when the ECM is in the AUTO mode.

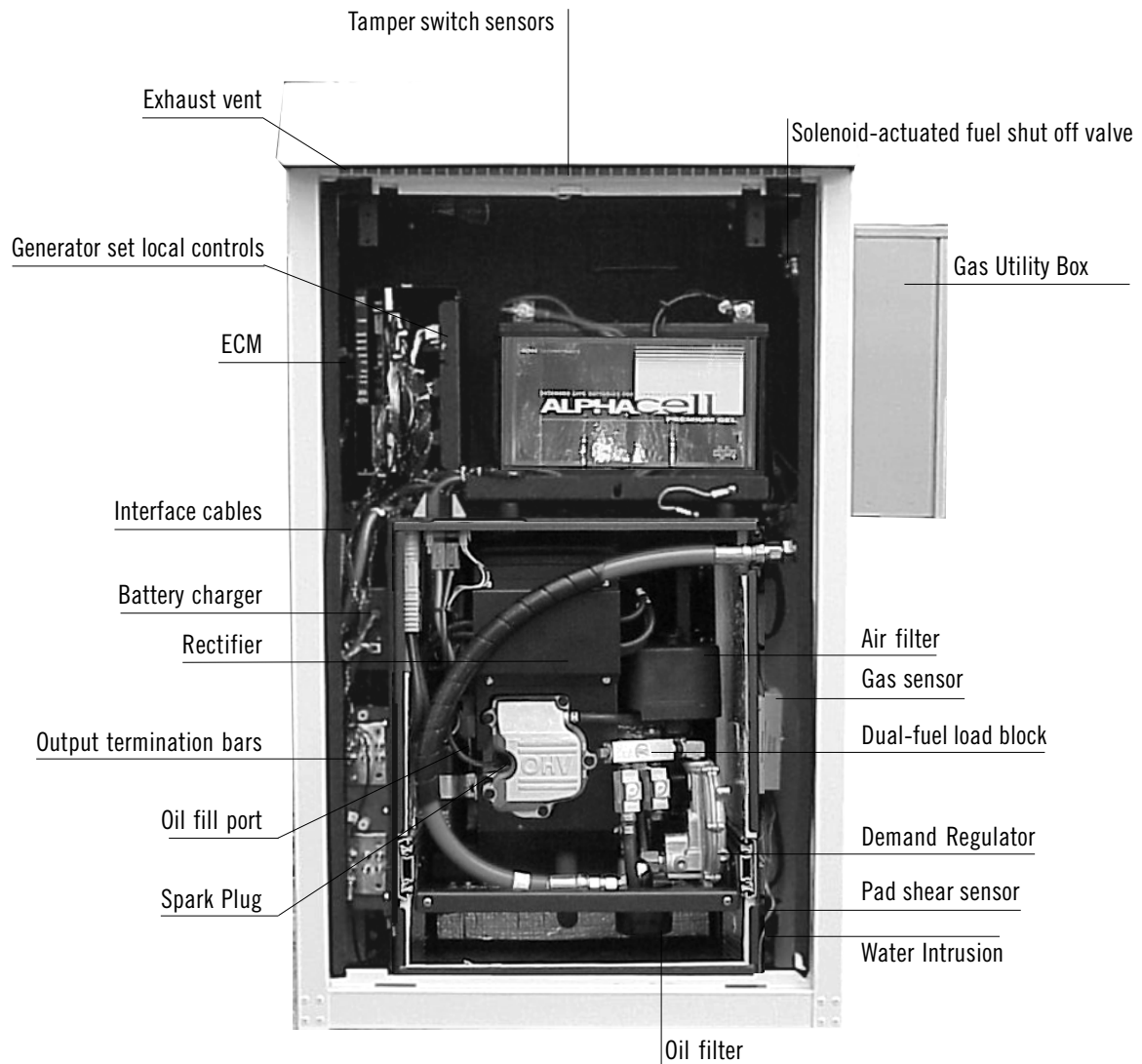

Fig. 1-2 Cabinet Component layout

1.2 Specifications

Nominal system specifications:

	3.5kW APU(5kW APU)
DC Output voltage	-52.0V ± -0.5V @ no load
DC Output load regulation	0.5V
Output current	48V, 67A max. (48V, 96A max.)
Engine (air cooled)	400cc 14hp rated Single OHV
RPM	3900 RPM max. variable speed
System size:	
Height	44"
Width	26"
Depth	24"
Weight	445lbs.
 APU Fuel Consumption	
Propane - 2520 BTU/ft ³	0.88gal/hr. (1.00gal/hr.) 31.78ft ³ /hr (40.0ft ³ /hr) 3.72 lb/hr (4.68 lb/hr)
Natural Gas 1000 BTU/ft ³	80 ft ³ /hr (90 ft ³ /hr)
Gas Inlet Pressure	0.5-2 psi
Ign. charger voltage	13.8-14.4 VDC
Ign. charger current	6A max.
Remote Interface Length	75' max. (50' max.)
	<i>NOTE: For greater distances, contact Alpha's Applications Engineering Department.</i>
 Agency compliance	
	UL2200 (UL2200) NFPA 37/54/58 CSA 22.2

Fuel System Controls & Monitoring:

The controls and fuel system meet appropriate sections of NFPA 37,54, and 58 for automatic, unattended operation of remotely enclosed generators.

Full System Control and Status Monitoring included on all models.

Sensors:	Gas Hazard, Pad Shear, Water Intrusion, Tamper
Safety Shutdowns:	Low oil shutdown Oil over-temp Engine overspeed Over-crank (Crank limit) Gas hazard (Propane or Natural Gas) Low fuel pressure shutdown (Propane only) Water intrusion Pad shear

1. System Overview

1.3 APU Overview

Alpha's Auxiliary Power Unit (APU) provides a second source of power from which the power supply systems can draw, in the event that the utility power supplied to the system is lost or unacceptable (i.e., low or high voltage, noisy, unstable, etc.). It consists of a gas driven (natural or propane vapor) engine/ alternator (DC).

The 3.5kW/5kW version of the CE3X-2 AlphaGen system is ideally suited to provide unlimited standby operation of approximately 100 hours (based upon fuel capacity and oil capacity) up to nameplate rating. The 14hp-rated single-cylinder overhead valve (OHV) engine used in this application drives a direct-connect, variable-speed, 3-phase permanent magnet generator to produce a high-frequency AC power. A 3-phase full-wave rectifier in the control system rectifies the output to produce low-ripple DC power. A Capacitor filter ensures Telephony-grade low-noise DC output. A DC in-line fuse provides protection for downstream devices in the event of overload or accidental short circuit.

CEX Series APU Enclosure

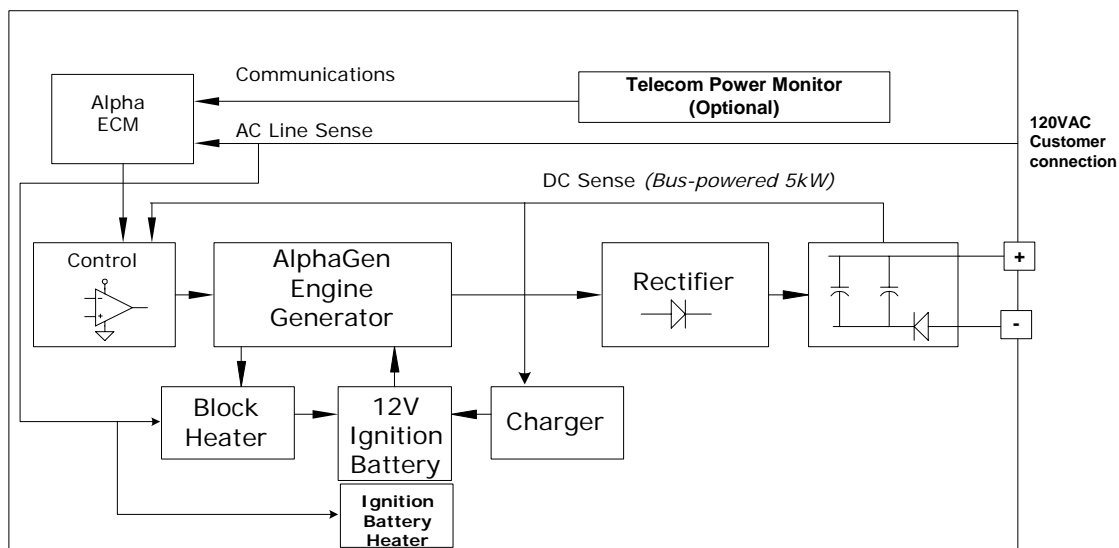
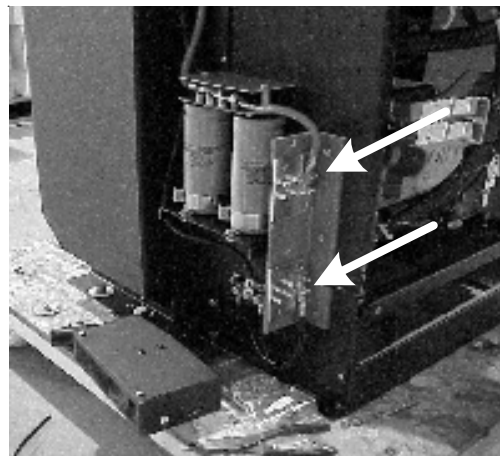

Fig. 1-3 System Block Diagram

The DC output of the APU is routed to either the Positive (+) and Negative (-) termination bars (equipped with 1/4" studs on 5/8" centers for customer-provided cabling termination), or 175A S.M.H./Anderson output connector.



1.4 Engine Control Module Overview

The primary purpose of Alpha's Engine Control Module (ECM) is to control and monitor an AlphaGen Auxiliary Power Unit (APU) set, such as the CE-3X2 3.5kW and 5.0kW Series Engine-Generators. The ECM is used in conjunction with a Generator Remote Interface (GRI) PCBA, often referred to as the Power Board. The ECM/Power Board Assembly is mounted to the top of the Engine-Generator housing, to the left of the ignition battery. The Power Board is attached to the ECM via three ribbon cables.

The GRI provides power to the ECM, steps down high voltages for the ECM, and provides interface connectors for the enclosure sensors, engine controller, battery sense, line sense, and other equipment. Depending upon the standby powering configuration, the ECM and generator combination are installed remotely, or co-located, with other Alpha equipment such as power supplies and batteries.

The Engine Control Module monitors AC line and DC bus status to determine when to start and stop the APU. In the event of an extended power outage or low battery bus voltage, the ECM will start the APU to prevent the backup batteries from discharging to a reduced voltage level which would compromise the ability of the system to provide a continuous, reliable source of power.

In addition to starting the APU, the ECM monitors the entire system for abnormal operating conditions such as low engine oil pressure, engine over-temperature, gas leak, enclosure pad shear, etc. If certain abnormal conditions or alarms are present, the ECM will either prevent the generator from starting or shut it down immediately. This provides for public safety, while preventing any serious damage to the APU. The system operator also has the ability to override the ECM and control the APU manually or remotely.

Finally, the ECM provides the interface between the APU and Alpha Technologies' communication devices such as the Telecom Power Monitor (TPM). The ECM is designed to control and monitor the APU while responding to commands and queries from a system controller via an isolated RS-485 data bus. Status information and alarms can be read from the ECM remotely via the data bus, locally from the Light Emitting Diodes (LEDs) on the unit's front panel, or by an optically isolated transponder interface. The ECM is capable of reporting 9 major alarms, 8 minor alarms, and 2 notifications.

1. System Overview

1.4 Engine Control Module Overview, *continued*



Fig. 1-4 Location of Engine Control Module within the Engine-Generator Cabinet.

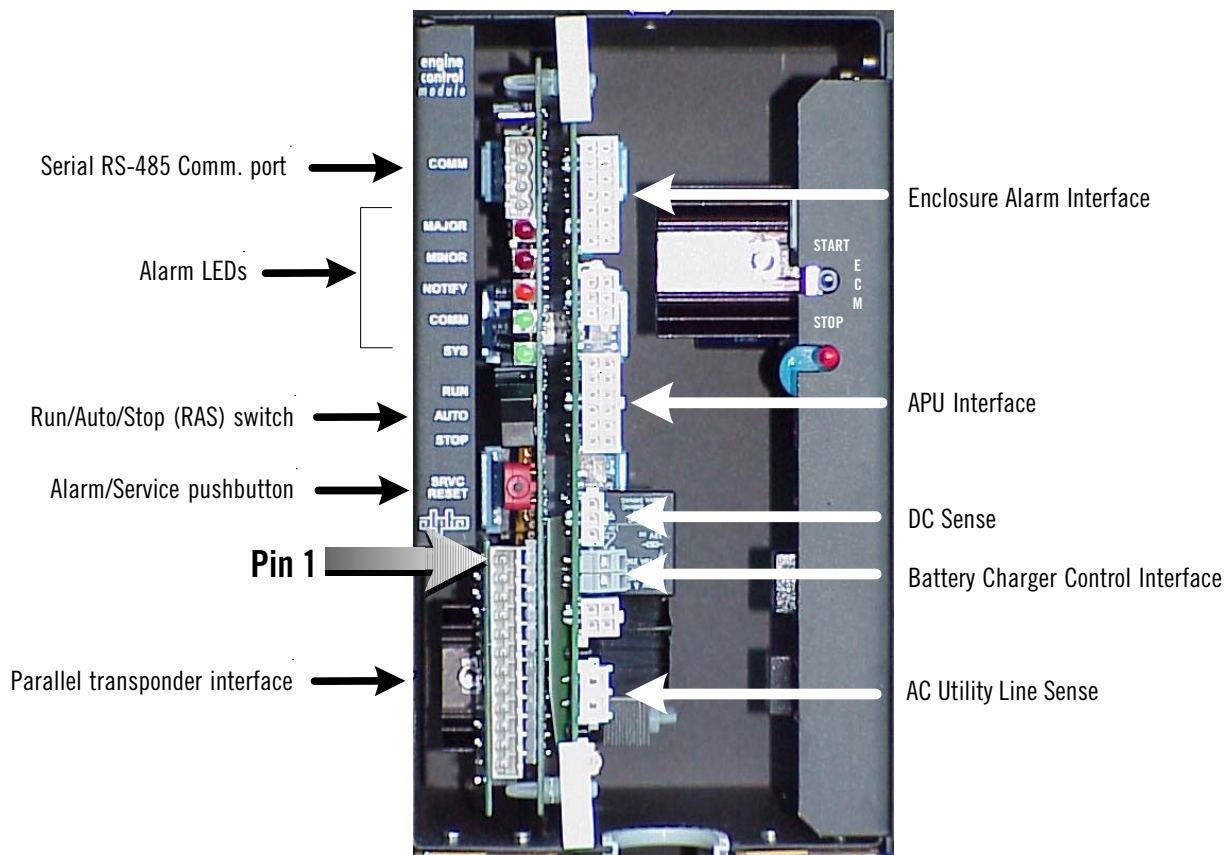

Fig. 1-5 Front view, Engine Control Module (ECM)

1.5 Generator Modes of Operation

1.5.1 Normal Operating Condition

Under normal operating conditions (no alarms) the ECM's Run-Auto-Stop (RAS) three-position rocker switch will be in the "center" or AUTO position as shown in figure 1-6. The ECM has complete control over the APU while in the AUTO mode. Also, each time the RAS switch is moved from the STOP position, to the center or AUTO position, the ECM will run the APU for one minute after a short delay. This is an indicator to the system operator that the ECM is truly in the AUTO mode and is fully capable of starting and stopping the APU automatically.

The APU can be controlled manually by placing the RAS switch in the "up" or RUN position and the "down" or STOP position. If a system controller is attached to the ECM via the RS-485 bus, the APU can be controlled remotely. Similarly, the APU can be started via the transponder interface on the ECM.

In the AUTO mode, the ECM continuously monitors the AC line voltage, and DC bus voltage, enclosure sensors, and the APU status. If a fault occurs, the ECM will determine whether to start or inhibit the APU based on the type of failure.

1.5.2. Standby Operating Condition (less than 3 minutes)

If an AC line disturbance or outage is less than 3 minutes, the ECM will not start the APU unless the battery bus voltage drops below a programmable threshold (Low DC Bus Level) which defaults to 1.95 Volts per cell or 46.8 Volts for 48 Volt systems. However, the ECM will notify the system operator of a line failure via the front panel LED's (see alarm section). Otherwise, the ECM will appear to be in a "normal" operating condition.

1.5.3. Standby Operating Condition (more than 3 minutes)

If an AC line disturbance or outage is greater than 3 minutes, the ECM start delay timer will expire and the ECM will attempt to start the APU. The ECM will attempt to start the engine 9 times with either a 30 second or a 60 second pause between attempts (See table 1-1). If the engine fails to start, the ECM will report an "Engine Over-crank" alarm. Otherwise, the ECM will start and continue to run the APU until either a normal shutdown or Major alarm occurs (refer to Alarm section 1.7).

1. System Overview

1.5 Generator Modes of Operation, *continued*

Crank Cycle									
Crank Attempt	1	2	3	4	5	6	7	8	9
Cranking Engine	15 sec.	15 sec.	15 sec.	15 sec.	15 sec.	15 sec.	15 sec.	15 sec.	15 sec.
Pause (no crank)	30 sec.	30 sec.	60 sec.	30 sec.	30 sec.	60 sec.	30 sec.	30 sec.	Engine Overcrank

Table 1-1 Normal Mode Crank Cycle

1.5.4. Normal APU Shutdown

The ECM will initiate a normal APU shutdown when AC line is qualified, DC bus alarm is not active, the 12 minute cool-down period has elapsed, and the Engine Run command is not active. Otherwise, the ECM will continue to run the APU until the above conditions are met or a major alarm occurs. Also, the APU will run for a minimum of 30 minutes if started due to low DC Bus voltage.

1.5.5. Abnormal APU Shutdown

The ECM will immediately shutdown the APU under the following conditions:

- Major alarm
- Activation of manual engine stop switch
- Receipt of software engine stop command
- General generator failure

1.5 Generator Modes of Operation, *continued*

1.5.6. ECM Operating Mode Summary

The ECM monitors the status of the AC line and DC bus to make a determination when to start and stop the generator. The ECM also monitors APU status while the engine is running and will immediately shut down the unit if certain alarm conditions are detected. The ECM reports status information via a parallel data interface and/or an Alpha-Bus serial data (RS-485) interface.

Any of the following conditions can cause the ECM to start the generator:

1. Loss of AC line for a period of time in excess of *Start Delay* (Programmable - 3 minutes default).
2. DC bus voltage drops below "LOW DC BUS" (Programmable - 49V default).
3. Manual run switch is activated.
4. Software run command received.
5. Engine run is commanded via the transponder interface.
6. A self-test is initiated manually.
7. An automatic self-test is initiated.

The following conditions are required for normal engine shutdown:

1. AC line is qualified.
2. DC bus voltage is greater than 2.0 V/cell + 2 Volts (i.e., 50.0 Volts).
3. Cool-down period has expired.
4. Engine Run command is not active.
5. Engine has run for a minimum of 30 minutes if it started due to low DC bus voltage.

The following conditions will cause immediate engine shutdown:

1. Manual engine stop switch is activated.
2. Software engine stop switch is received.
3. Any of the following engine alarms become active:
 - Low oil
 - Engine over-temperature
 - Low fuel
 - Over-speed
 - Over-crank
 - Overvoltage
4. Any of the following system alarms become active:
 - Gas hazard
 - Pad shear
 - Water intrusion
 - General APU failure

1. System Overview

1.6 Operator's Interface Overview

Refer to Figure 1-6 on the following page:

The three positions of the rocker switch are RUN - AUTO - STOP (RAS). The RAS switch is normally left in the center, AUTO, position so that the ECM has control of the generator set. A minor alarm is indicated when the RAS switch is not in the AUTO position. The STOP ("down") position is used to stop or prevent APU operation during maintenance. **Placing the RAS switch to the STOP position for three (3) seconds, then switching back to AUTO will clear any latched alarms and start the generator if the cause of the alarm has been corrected.** Placing the RAS switch in the RUN ("up") position will cause the engine to start and run until this switch is released to AUTO. The engine may not shut down immediately when the switch is returned to AUTO from RUN, because the ECM's shutdown criteria must be met in order to shutdown the engine. Also, each time the RAS switch is placed in the AUTO position (from the STOP position), the ECM will start and run the APU for one minute after a short delay.

The service reset push-button switch has two purposes. It resets the engine service timer when depressed for 5 seconds and can be used to determine which alarms are active (see "**Alarms**" section 1.7). The service interval is a programmable counter within the ECM that after the initial notification for 25-hour service, defaults to 100 hours. When 100 hours of engine run time elapses, the *Service Required* notification is set and the notification LED illuminates. After the engine has been serviced, pressing and holding the service reset switch for 5 seconds will reset the 100-hour service counter. All of the LEDs flash, while the switch is depressed, until a five-second timer elapses at which time all of the LEDs remain on solid until the switch is released. This provides feedback to the technician, indicating the effective resetting of the engine service counter.

1.6 Operator's Interface Overview, *continued*

The service reset push-button is also used to obtain information about active alarms. The Major and Minor alarm LEDs are very general and a technician will need more detailed information upon arrival to the site of an alarming ECM. To retrieve details about an active alarm, the user presses and releases the service-reset switch. An active alarm (Major or Minor) will be indicated by the LEDs as indicated in Table 1-2.

NOTE:  Depressing the service-reset switch for 5 seconds will cause the service timer to clear possibly disrupting the preventive maintenance schedule.

When the service-reset button is pressed again, the LEDs will represent the next active alarm. Pressing the button when there are no more active alarms will reset the LEDs to their normal usage. Several quick flashes of all five LEDs will indicate end of the alarm list before the LEDs return to normal operation. If the service reset button is not depressed again when an alarm is indicated, the LEDs will return to normal operation after 30 seconds have elapsed. Resetting alarms via status monitoring or via the manual stop switch will also clear the alarm pattern indicated by the LEDs.

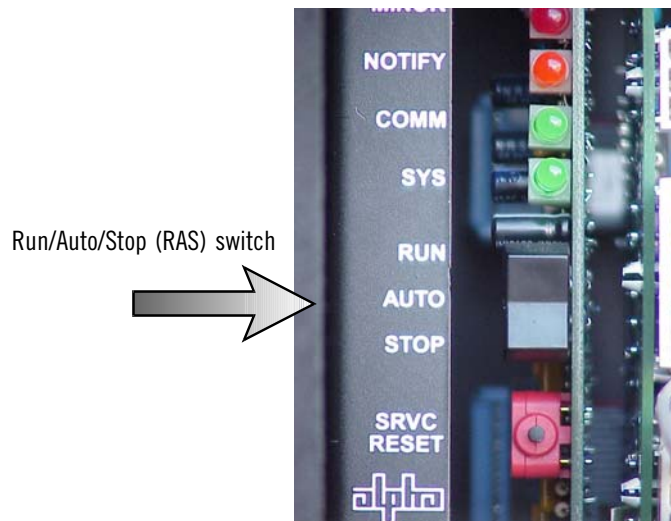

Fig. 1-6 Detail of Run-Auto-Stop (RAS) switch

1. System Overview

1.7 ECM Alarm Overview

Alarms are indicated in three ways: ECM LEDs, RS-485 communications and alarm contact closures on ECM transponder interface. Alarm indication on the ECM LEDs is obtained by pressing the service reset button momentarily and noting the combination of illuminated LEDs. Pressing the service reset switch again will reveal the next alarm in the list. When the alarm list has been exhausted, all LEDs will flash several times and then return to their normal functions. **Placing the RAS switch to the STOP position for three (3) seconds, then switching back to AUTO will clear any latched alarms and start the generator if the cause of the alarm has been corrected.** The following figures show the LED patterns and the alarms they represent.

Major Alarms	1	2	3	4	5	6	7	8	9
Abbreviation	LO	OT	OS	OC	OV	GH	WI	PS	LP
Major									
Minor									
Notify									
Comm									
Sys									

Minor Alarms	10	11	12	13	14	15	16	17	18	19
Abbreviation	CF	AO	TF	IB	AD	TP	DC	ED	LF	SR
Major										
Minor										
Notify										
Comm										
Sys										

Table 1-2 Major, Minor Alarm Indications, and Notifications
(LEDs as displayed on the ECM)

- | | |
|--------------------------------|-------------------------------|
| 1. Low Oil Pressure (LO) * | 10. Control Fail (CF) *** |
| 2. Engine Over-Temp (OT) | 11. Alternator OFF (AO) |
| 3. Engine Over-Speed (OS) * | 12. Self-Test Fail (TF) * |
| 4. Engine Over-Crank (OC) * | 13. Low Ignition Battery (IB) |
| 5. Alternator Over-Volt (OV) * | 14. Auto-mode Disabled (AD) |
| 6. Gas Hazard (GH) * | 15. Tamper (TP) |
| 7. Water Intrusion (WI) | 16. DC Bus fault (DC) |
| 8. Pad Shear (PS) * | 17. Engine Disable (ED) |
| 9. Low Fuel Pressure (LP) *** | 18. Line Failure (LF) ** |
| | 19. Service Required (SR) ** |

Legend:

- * = Latching Alarm
- ** = Notifications
- *** = Alarm "latches" after 5 activations

1.8 Propane Enclosure Overview

The CE-X series engine generator enclosures have the capability of either vapor fuel configurations, Natural or Propane vapor withdrawal. As shown below, several safety features were added to ensure the cabinets comply with applicable sections of NFPA 54 (National Fuel Gas Code), NFPA 58 (Storage and Use of Propane), and NFPA 37 (Engine generators) regarding proper spacing between intake vents to combustible openings and venting devices on propane systems.

The CE-X series enclosures are air-cooled. The air intake is through the bottom rear of the enclosure, and the forced-air exhaust is via the upper duct on the front roof. The Propane compartment front door is louvered to allow adequate airflow to atmosphere. The distance between these two points is greater than 5 feet and is on opposite sides of the enclosure to prevent communicable air spaces.

To prevent the enclosures from having the doors placed on the wrong sides, thereby violating the codes, the bottoms of the doors are keyed in a way that cannot allow incorrect airflow patterns. During operation, maintenance, or propane tank replacement, the doors must be installed properly.

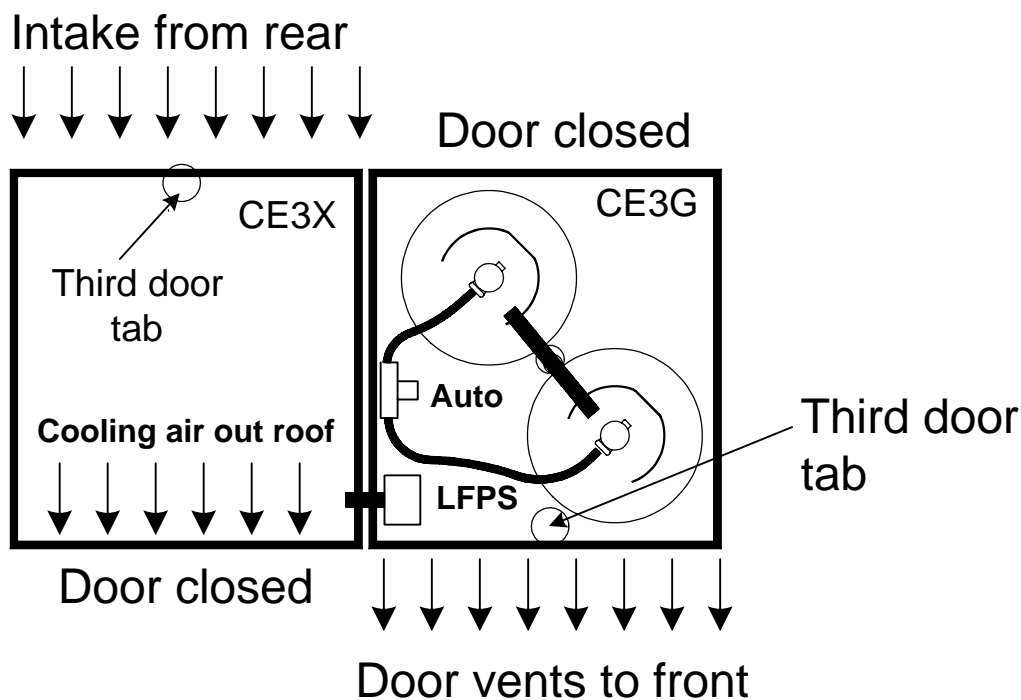

Fig. 1-7 Overhead view, airflow patterns

1. System Overview

1.8 Propane Enclosure Overview, *continued*

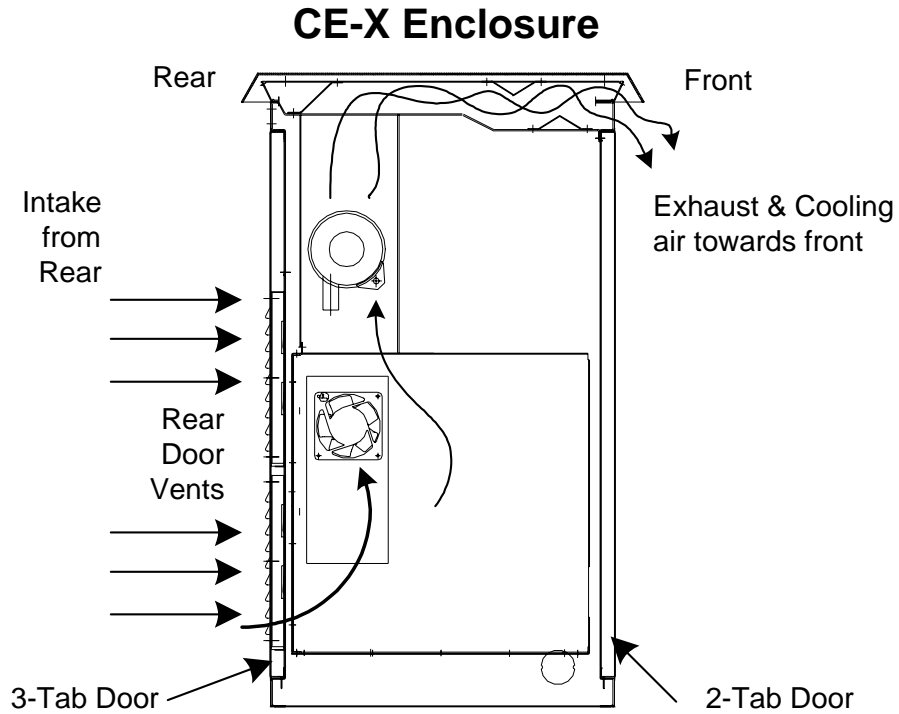

Fig.1-8 Airflow patterns, CE-X Enclosure

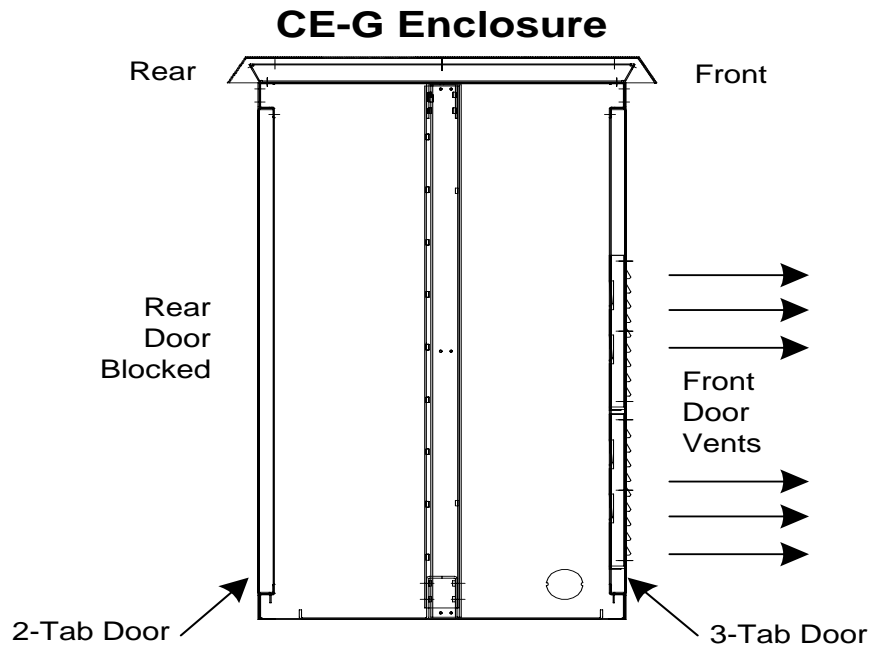

Fig. 1-9 Airflow patterns, CE-G Enclosure

2.1 Appearance and condition of components

Prior to applying the power, note the condition of the outside of the unit.

Open each door of the enclosure. Observe and note the condition of the following:

For each (front and rear) door assembly:

1. Doors and locking mechanisms.
2. Seals.
3. Door Intrusion switches.

2.2 Initial Operation

The following procedure involves starting and stopping the engine using the Engine Control Module (ECM). For the purpose of this procedure, it is assumed that the engine is properly connected to the 12 Volt ignition battery and that the natural gas (or propane vapor) fuel has been installed, pressurized and tested for leaks. Refer to the CE3X2 Telecom Series Enclosure Installation manual (p/n 031-099-C3) for wiring diagrams and information pertaining to the battery connections.

All engine operation will be controlled by the ECM. Verify the switch on the generator control board is switched to the center (ECM) position. *See Fig. 2-2.*



NOTE: Refer to the ECM Operator's Manual (p/n 744-862-C0) for complete ECM operating instructions.

2.2.1 Ignition Battery Test Procedure

1. Connect a DVM (set for DC Volts) to the IGN BATT terminals. Connect the Red (+) lead of the DVM to the (+) terminal and the Black lead (-) of the DVM to the (-) terminal.
2. The DVM should indicate 12 VDC (+ 2 V , - 0 VDC). If this reading is lower than specified, recharge the batteries to 13.8 VDC before proceeding.



WARNING: Do not use batteries (AGM or Gell Electrolyte) that read below 9.0 VDC, as the battery may be discharged below a safe point and could cause gassing during recharge.

2. Turn-Up and Test

2.2 Initial Operation, *continued*

2.2.2 Engine Lubrication

Check Engine lubrication Level Procedure:

Check the engine crankcase oil level. If necessary, add oil to fill it to the FULL mark. **DO NOT OVERFILL.** Refer to the engine manufacturers' operator's manual for proper fill capacities and oil types. Ensure that the same brand of oil is used for topping the oil level, as some oil manufacturer's additives are not compatible with each other. Never attempt to measure the oil level, or add oil, when the engine is in operation.



CAUTION: Do not attempt to crank or start the engine before it has been serviced with the recommended oil, or engine failure will result.



NOTE: Refer to the Alpha 5 Generator *OPERATOR'S* manual (p/n Tp-6076) provided by the manufacturer.

2.2.3 Starting a Local APU Test

Procedure:

1. Locate APU control board (mounted alongside the ECM).

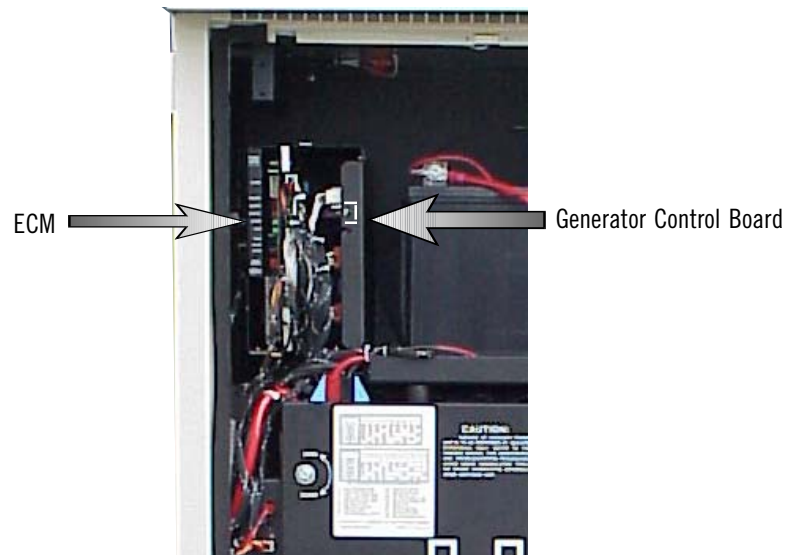

Fig. 2-1 Location of APU Control Board

2.2 Initial Operation, *continued*

2.2.3 Starting a Local APU Test

2. Place generator set master switch to the middle (ECM) position.



CAUTION: The Generator set master switch will override the Run/Auto/Stop (RAS) switch on the ECM. This switch is normally left in the middle, or “ECM” position.



Fig.2-2
Generator Control Board
master switch

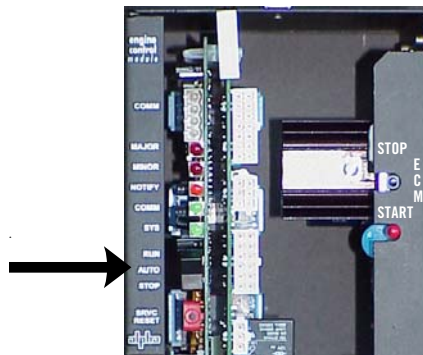

Fig. 2-3
Location of ECM Run/Auto/Stop switch

3. Set RAS switch to “STOP”
4. Verify Ignition Battery & AC Line Sense connection to ECM.
5. Verify all alarms on ECM are OFF except **Tamper Alarm & Auto Mode Disabled**.
6. Remove gas port plug from input side of demand regulator, install brass manometer port connection fitting and connect manometer to fitting (Refer to fig. 3-1, and Section 3-17 for further details).
7. Move **RAS** switch from “**STOP**” to “**AUTO**”.
8. Verify the engine starts within 3 salvo cycles per Table 1-1, Normal Mode Crank Cycle.
9. If engine fails to start within 3 salvo cycle and **Engine Over Crank** is activated, the gas line needs to be purged by removing air filter and placing hand over the carburetor throat to choke while cranking engine until engine starts.
10. Verify 11” of water column pressure is present at the input of the demand regulator.
11. Adjust pre-regulator, or dual regulator (located on gas bottle assembly for Propane) if necessary by removing regulator cap and adjusting for 11” +/- 1” of water column pressure.
12. Set RAS to “STOP”.
13. Remove brass manometer fitting and re-install plug to demand regulator input monitoring port using approved pipe sealant.
14. Check demand regulator input monitoring port for leaks.
15. Set RAS to “AUTO”.
16. At this point, if the APU has passed the pre turn up inspections and has been successfully started and stopped as part of the local tests, the unit is now ready to be placed into service.

End of Turn Up and Test Procedure.

2. Turn-Up and Test

2.3 Generator System Sensor Verification

The ECM has a built-in self-test feature. Each time the ECM's Run-Auto-Stop switch is placed in the Auto Position, a one-minute self-test is performed and any failures will be reported as major or minor alarms. Latched alarms can be reset after the fault has been cleared by placing the RAS switch to the Stop position for 3 seconds and then back to the Auto position.

2.3.1 Enclosure Alarm Verification

1. Place the RAS switch in the Auto position. Verify the generator runs for one minute and the only alarm reported by the ECM is a minor "Tamper" alarm.
2. Place the RAS switch to Stop for three seconds and then back to Auto to start a generator self-test. During the one-minute self-test, insert a 1/16"-1/8" thick metal object between the Pad Shear magnet and the Pad Shear sensor. Verify the generator stops running and the ECM reports a major "Pad Shear" alarm.
3. Place the RAS switch to Stop for three seconds and then back to Auto to start a generator self-test. During the one-minute self-test, trip the gas sensor by placing a cloth moistened with isopropyl alcohol directly on the gas sensor for at least three seconds. The red LED on the Gas sensor must illuminate for three seconds before the ECM will recognize and report the alarm. Verify the generator stops running and the ECM reports a major "Gas Hazard" alarm.



NOTE: Gas from an unlit butane lighter can also be used to trip the gas sensor.

4. Place the RAS switch to Stop for three seconds and then back to Auto to start a generator self-test. During the one-minute self-test, trip the Water Intrusion sensor by lifting the small plastic float located near the Pad Shear sensor. Verify the generator stops running and the ECM reports a major "Water Intrusion" alarm.



NOTE: The Water Intrusion alarm is non-latching (self-clearing) and needs to be activated in order for the ECM to report an alarm.

2.3 Generator System Sensor Verification, *continued*

2.3.2 AC and DC line Sense Verification

The ECM monitors AC line and DC bus status to determine when to start and stop the APU. In the event of an extended power outage or low battery bus voltage the ECM will start the APU. The following test will verify these functions.

1. Verify the ECM is in the Auto position, the APU is not running, and there are no major or minor alarms reported other than "Tamper". Remove the DC sense cable from the front of the ECM (see figure 1-5). Verify the APU starts running and the ECM reports a minor "DC Bus Fault" alarm. Replace the DC sense cable and verify the alarm clears.



NOTE:

As the ECM will continue to run the APU for 30 minutes after the "DC Bus Fault" alarm clears, the technician may move the RAS switch to the STOP position after 4 to 5 minutes

2. Verify the RAS switch is in the Auto position, the APU has run for 1 minute. Remove the AC Utility Line sense cable from the front of the ECM (see Fig. 1-5). Verify the ECM reports a "line Failure" notification and the APU starts running after a 3 minute time delay. Replace the AC Utility Line sense cable and Verify the notification clears. Verify the APU will continue to run for a 12 minute "cool down" period after the "Line Failure" notification clears.

3. Maintenance

3.1 Cleaning and Lubrication

The Auxiliary Power Unit, being a gas-driven, air-cooled, combustion engine, requires periodic maintenance. Maintenance items may include: changing the engine oil at recommended intervals; cleaning and/or replacing the engine air filter; checking the intake and exhaust vents and fans for proper operation; and cleaning and/or replacing the enclosure filters.



NOTE:

A corrosion-inhibiting coating (such as LPS3 by LPS Corp.) must be used on all exposed connector assemblies and reapplied annually per the manufacturer's instructions.

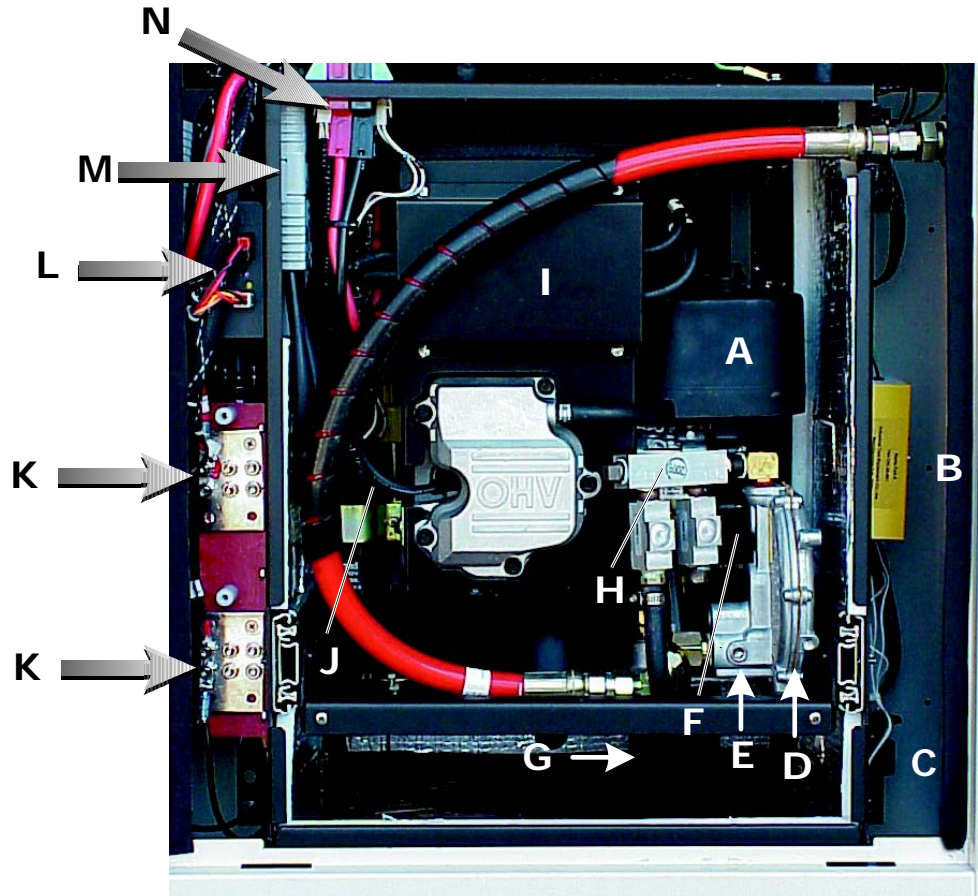

Fig. 3-1 APU compartment

- A. Air filter cover
- B. Gas Hazard Sensor
- C. Mounting bracket for Water Intrusion and Pad Shear Sensor
- D. Fuel Demand Regulator
- E. Manometer Port (for gas pressure test purposes only)
- F. Run Time Indicator (Hour meter)
- G. Oil Filter
- H. Dual-Fuel Load Block
- I. Rectifier Cover
- J. Oil Dipstick
- K. Termination Bars
- L. Ignition Battery Charger
- M. DC Output Connector
- N. Ignition Starter Battery Cable

3.2 Scheduled Maintenance

3.2.1 Maintenance Intervals

The engine/alternator requires maintenance at regular intervals to remain reliable and ready to provide backup power when needed. Please refer to the following table for general maintenance guidelines. For specific recommendations regarding maintenance intervals, please refer to the supplied engine manufacturer's operator's manual.

System component or Procedure	Procedure X = Action, R = Replace as Necessary					Frequency
	Visual Inspection	Verify	Change	Clean	Test	
FUEL						
Inspect flexible lines and connections	X		R			Q
Check main LP tank supply level		X				W
Inspect Fuel piping	X					Y
LUBRICATION						
Check Oil Level	X	X				Q
Change Oil			R			Y or 100
Replace oil filter			R			Y or 200
COOLING						
Verify air ducts and louvers are free from debris		X		X		Y
EXHAUST SYSTEM						
Check for leakage. Carbon or soot residue indicates leaks. Repair immediately.	X	X	X			Y
Check for fire hazards	X					Y
Check for loose or broken hangers and supports. Tighten or replace as needed.	X		R			Y
BATTERY CONNECTIONS						
Check battery charger operation, charge rate	X					M
Clean, re-torque battery terminals	X	X		X		Y
ELECTRICAL SYSTEM						
General inspection	X					Q
Inspect cables for abrasion (Generator compartment)	X	X				S
Reapply corrosion-inhibiting coating on all exposed connector assemblies			X			Y
ENGINE & MOUNTING						
General Inspection	X					W
Inspect air cleaner element			R			Y or 500
Inspect spark plugs			R			Y or 500
CONTROL SYSTEM						
Verify remote control operation					X	M
Run generator set					X	W
GENERATOR SET						
Inspect generator set	X					Prestart
Exercise generator set					X	M
GENERAL CONDITION OF EQUIPMENT						
Check for signs of damage due to vibration, leakage, excessive noise, extreme temperature, or deterioration.	X	X		X		W
Inspect and clean cabinet interior	X			X		Q

D = Daily, W= Weekly, M = Monthly, Q = Quarterly, S = Six months, Y = Yearly, No. = Hours

Table 3-1 Scheduled Maintenance

3. Maintenance

3.2 Scheduled Maintenance, *continued*

3.2.2 ECM Service Required Notification

The ECM monitors time between periodic maintenance of the engine-generator. The *Service Interval* internal ECM variable represents the number of hours of engine-run-time between periodic services. When the engine runs for a number of hours equal to *Service Interval*, the ECM sets the *Service Required* Alarm and turns on the amber notification LED. The default value of *Service Interval* is 100 hours but it can be programmed from 0 to 250.

Service Due represents the number of engine run time hours before the next periodic maintenance will be required. Pressing and holding the service-reset switch for 5 seconds resets the service counter and *Service Due* is updated with the current value of the service interval.

An exception to the standard *Service Interval* occurs when the engine is new. At 25 hours of *Engine Run Time*, the ECM will set the *Service Required* flag. 25 hours represents the break-in period of the engine, which should be serviced at this time. Note that if a service-reset is performed before the *Engine Run Time* counter reaches 20 hours, the *Service Required* flag will still be set at 25 hours. If, on the other hand, a service-reset is issued when the engine more than 20 hours, the *Service Countdown* will be set to *Service Interval*.

3.2.3 ECM Self-Test Features

Generator testing can be initiated in four ways:

1. The ECM can be programmed to periodically run an automatic test (*Default OFF*).
2. A Self-Test can be commanded via status communications.
3. Momentary activation of the Engine Run command will cause the ECM to effectively run a test. Note that this method is the least desirable because the *Self-Test Fail* alarm will not be set if an alarm condition arises.
4. A one-minute automatic test is performed when the manual control switch is returned to *Auto* from *Stop*.

Generator testing consists of starting and running the generator for a programmable period of time (the default test duration is 10 minutes). The ECM monitors all engine-related signals and will declare a self-test as failed if any of the following alarms activate during the test:

- Low Oil Pressure
- Engine Over-temperature
- Engine Over-speed
- Engine Over-crank
- Low Fuel
- Alternator Over-voltage
- ECM Control Failure
- Alternator Not On
- Low Ignition Battery
- Low DC Bus Voltage

The ECM will not start a self-test if the engine is disabled, the stop switch is asserted, or the engine is already running.

3.2 Scheduled Maintenance, *continued*

3.2.3 ECM Self-Test Features, *continued*

If AC line should fail during a test, the test will terminate normally but the engine will continue to run until line returns. If the test fails because the DC Bus alarm activates, the test will terminate, the self-test fail alarm will activate but the generator will continue to run until the DC Bus alarm clears.

The Self-Test Fail alarm may be cleared via a reset command or by successfully running a subsequent test.

The programmable, internal ECM variables listed below control automatic self-tests.

Auto-Test Interval

This feature represents the number of days between automatic tests. Programming this variable to 0 disables the automatic test feature.

Auto-Test Countdown

This countdown timer is monitored by the ECM to determine when the next automatic test should be initiated. Although this timer is normally used as a status indicator, it can be used to set the start time for the next autotest. For example, if the user wants to start the automatic test sequence at 12:30pm and it is presently 10:15am, they can wait until 10:30 and program Auto-Test Countdown to 2 hours. Subsequent tests will begin at nearly the same time of day so long as the ECM doesn't lose power in the interim. The ECM sets Auto-Test Countdown whenever the Auto-Test Interval is changed. Thus, if the Auto-Test Interval is programmed to 10 days, the ECM will set Auto-Test Countdown to 240 hours.

Auto-Test Duration

The length of each Auto-test is measured in minutes. The default test duration is 10 minutes. The test duration may be set between 10 and 120 minutes.

Manually enabling the Autotest feature

Switch SW5-8 is used to enable the autotest feature with a 14-day test interval. The first autotest will begin 14 days from the time the ECM is powered up with the configuration switch changed from 0 to 1 (OFF to ON). To disable the autotest sequence, place switch SW5-8 in the OFF position and restart the ECM. It is important to understand that upon power up, the ECM looks for a **change** in the switch position before it changes the test control parameters. *(Please refer to ECM Manual, Alpha p/n 744-862-C0)*

3. Maintenance

3.3 Servicing the APU

Some tools and equipment may be required such as:

- Phillips screwdriver
- 10 mm socket wrench
- 3/8 inch open socket wrench
- DVM capable of displaying true RMS AC voltage and frequency (i.e., Fluke 87)
- Battery operated frequency counter (needed only if a frequency reading DVM is not available).

Some components on the APU are front accessible and do not require removing the APU during servicing:

Air filter replacement	Rectifier replacement
Oil filter	Spark plug replacement
Oil fill	Dual fuel load block (Propane/Natural Gas)
Demand regulator pressure tap	Electrical interface connections

If the APU has to be replaced because of failure, the following steps must be performed:



CAUTION: If unit is being serviced immediately after the generator has been in operation, allow sufficient time for Engine components to cool to prevent personnel from being injured or burned from the exhaust system.

1. Remove front and rear cabinet doors from the enclosure.
2. Remove APU Access door using a large straight slot screwdriver (turn the captive fasteners counter clockwise to loosen) and set door aside.
3. Set ECM Run/Auto/Stop switch to the STOP position.
4. Disable the APU by disconnecting APU control cables.

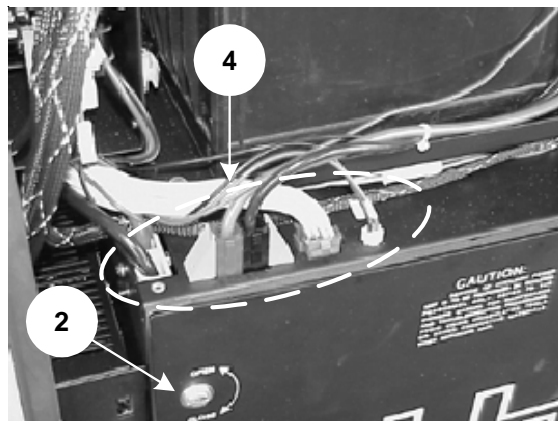

Fig. 3-2 APU housing door fasteners and control cables

3.4 Filter Cleaning

The air intake filter is located on the rear door.



WARNING:

Failure to keep the filters clean or using improperly installed filters, may cause internal system failures due to lack of cooling air or dirt buildup. Equipment failures caused from filter blockage or dirt ingress due to clogged or improperly installed filters is not covered under warranty.

Filter Removal, Replacement, and Cleaning

1. Unlock and remove the rear door.
2. Pull the four captive fasteners (item 1, below) out.
3. Tilt the filter frame away from the door and remove the filter.
4. Clean the filter using a vacuum or compressed air (if available) to remove loose dust and dirt. Then use a soap and water solution to remove any trapped dirt. Use compressed air to dry the filter. After cleaning, re-coat the filters using RP Super Filter Coat Adhesive, available from local suppliers.
5. Replace the filter (Verify the "Air Flow" indicating mark faces into the enclosure) and refasten the filter frame.
6. Replace and lock the rear door.

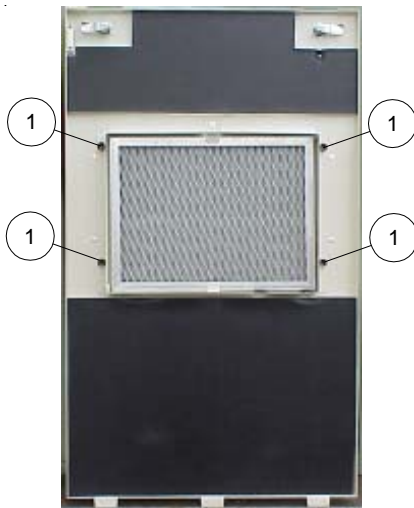

Fig. 3-3 Access Panel and Air Filter



Fig. 3-4 Air Filter Removal

3. Maintenance

3.5 PAD SHEAR Magnetic Switch and Water Intrusion Float

Allow 15 minutes for completion of procedure

Tools required: 3/8"-1/4"-5/16" wrenches
 Wire cutters
 Phillips screwdriver

Removal and replacement procedure:

1. Remove the APU housing access panel.
2. Locate and remove the switch and float mounting bracket as shown below.

The pad shear switch and water intrusion float bracket is located on the outside of the APU housing.



Location of bracket mounting nut (3/8") in lower portion of APU housing.

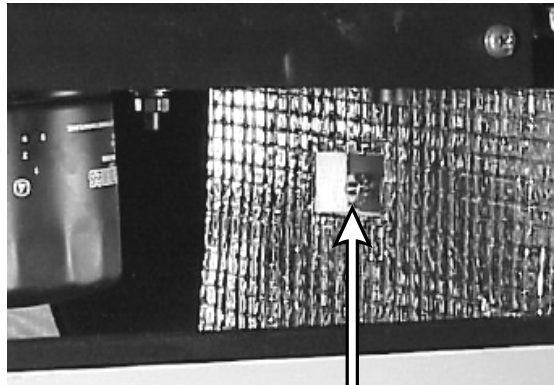

Remove bracket bolt with a 5/16" wrench. Set mounting hardware aside.

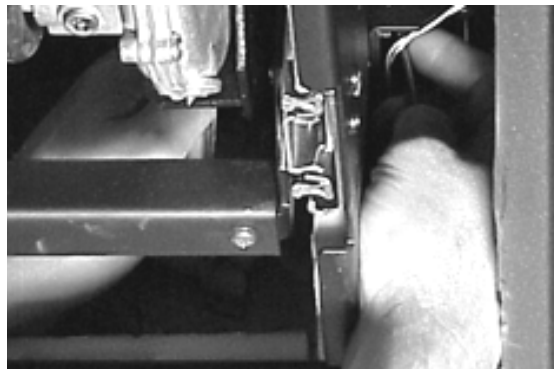

3.5 PAD SHEAR Magnetic Switch and Water Intrusion Float, *contd.*

Removal and replacement procedure (*continued*):

Cut wires to pad shear sensor. Use Phillips screwdriver to remove old switch.



Remove the mounting nuts which hold the water intrusion float to the bracket. Replace float and verify the magnet can slide freely up the mounting post, and that it rests against the retaining clip at the bottom of the mounting post.



Replace magnetic tamper switch with Phillips screwdriver. Splice switch wires to original wire harness. Replace the mounting bracket to its original position on the APU housing.



End of Procedure

3. Maintenance

3.6 Replacing GAS HAZARD Sensor

Allow 5 minutes for completion of procedure

Tools required:

Hook and loop fastener

Removal and replacement procedure:

1. Locate and remove the gas hazard sensor as shown below.

The gas hazard is located on the outside of the APU housing, above the pad shear/water intrusion sensor mounting bracket. It is attached to the APU housing by means of a hook and loop fastener.

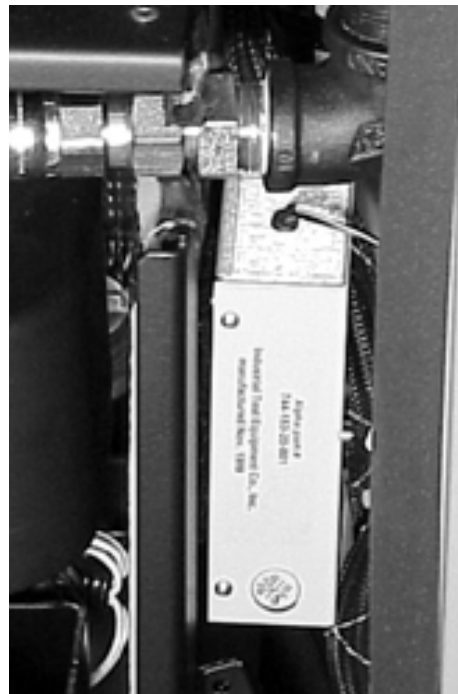

Pull the sensor free.

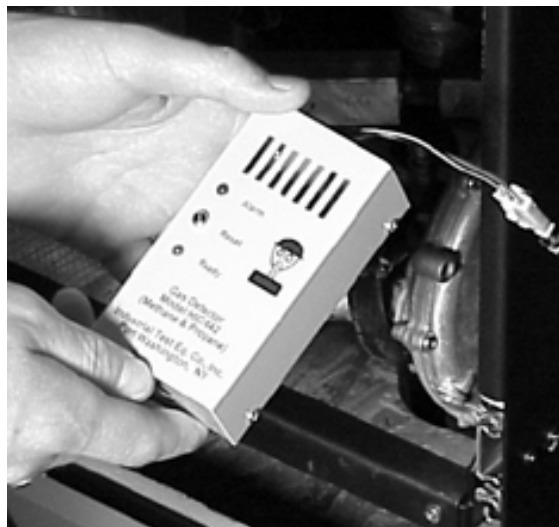

3.6 Replacing GAS HAZARD Sensor, *continued*

Removal and replacement procedure, *continued*:

Disconnect the sensor from the wire harness and replace with the new sensor. Add the opposite piece of the hook and loop fastener, and reinstall the sensor.



NOTE: Verify the replacement gas sensor is calibrated to detect the appropriate gas (i.e., Propane or Natural Gas).

End of Procedure

3. Maintenance

3.7 Replacing Ignition Battery Charger Module Assembly

Allow 15 minutes for completion of procedure

Tools required: #2 Phillips screwdriver

Removal and replacement procedure:

1. Locate and remove the charger module as shown below.

The charger module is a DC/DC converter and is located on the outside of the APU housing, above the generator run/stop switch mounting bracket. Disconnect the connectors from the front of the module.

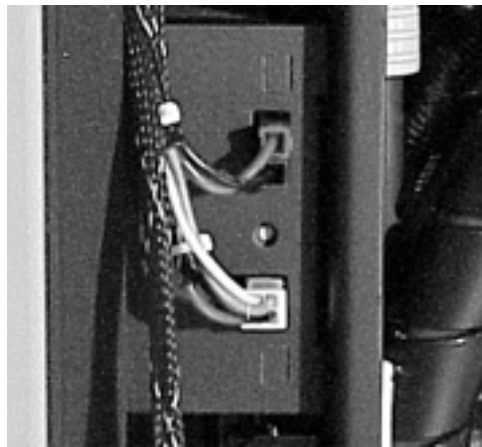

Use the #2 Phillips screwdriver to remove the two mounting screws from the inside of the APU housing.

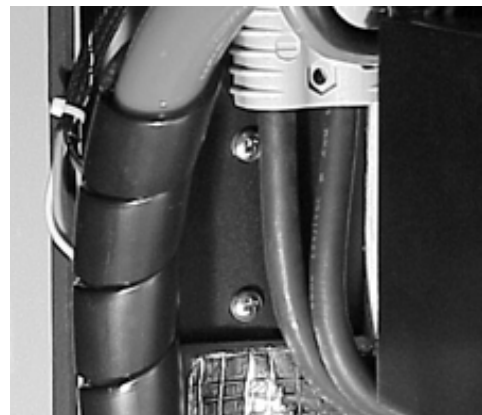

Slide the module out and replace with new charger unit.

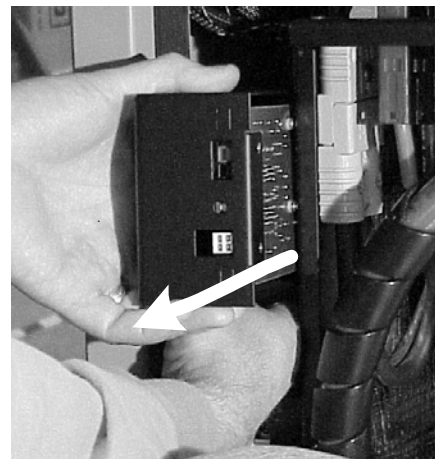

End of Procedure

3.8 Replacing Engine Control Module

Allow 5 minutes for completion of procedure

Tools required: None

Removal and replacement procedure:

1. Verify APU is OFF.
2. Locate and remove the ECM as shown below.

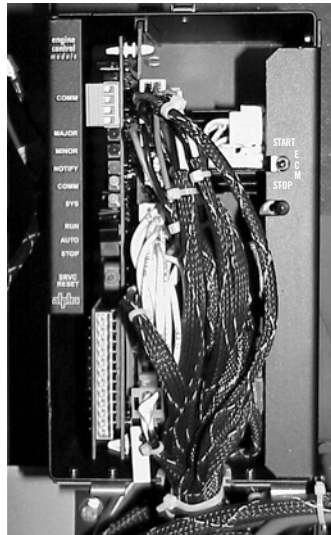

ECM in place with connectors attached

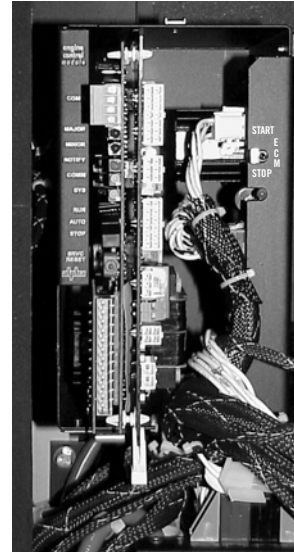

Remove connectors

Release ECM captive latch and slide PCBA from housing. Perform steps in reverse order to replace ECM.



3. Maintenance

3.9 Replacing Flexible Gas Hose

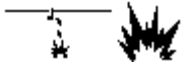

CAUTION:

It is important to install the hose properly to prevent gas leakage which could lead to explosion. This procedure must only be performed by a certified or qualified technician.

Allow 5 minutes for completion of procedure

Tools required: 15/16" open-end wrench

Removal and replacement procedure:

1. Verify fuel supply shut off.
2. Loosen upper (1) and lower (2) hose fittings.
3. Remove flexible fuel hose.
4. Reverse order of steps to replace hose.
5. Perform leak test with leak detection compound or gas detector.

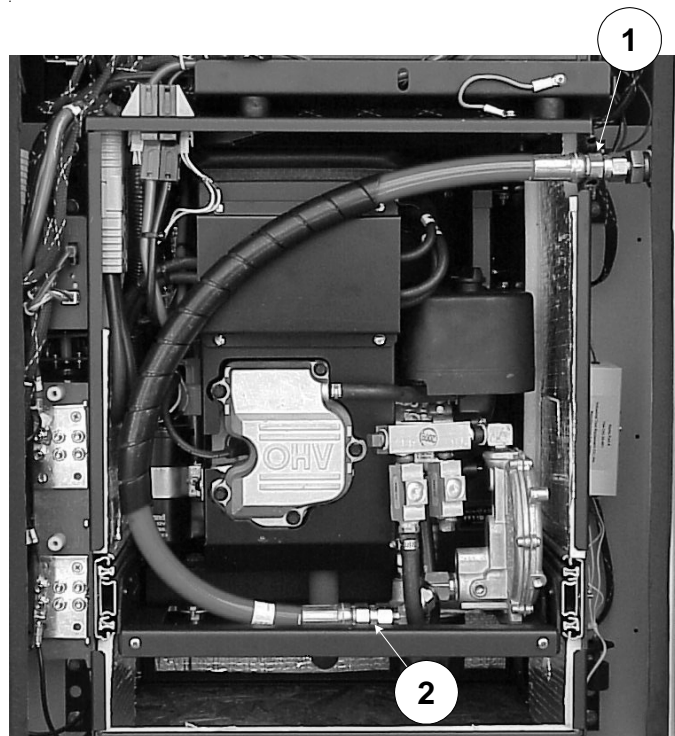

End of Procedure

3.10 Fuel Conversion - Natural Gas to Liquid Propane

3.10.1 Pre-regulator/Low Fuel Pressure Switch Replacement

Allow 10 minutes for completion of procedure.

Tools required: 7/8" open-end wrench

Repair and/or replacement procedure:

1. Verify fuel supply is shut off.
2. Disconnect wire/connector.
3. With 7/8" wrench, loosen pre-regulator fitting.



4. Pull wires through enclosure wall. Perform this procedure in reverse order to install a new pre-regulator.

During installation, verify the flange fitting is clean prior to making the connection (*It is not necessary to use sealing compound*).



5. Insert the wires into the enclosure, and install the two-pin connector.



NOTE: Perform the procedure in reverse order if converting the unit from Liquid Propane to Natural Gas.



End of Procedure

3. Maintenance

3.10 Fuel Conversion - Natural Gas to LP, *continued*

3.10.2 Dual-Fuel Load Block Conversion

Allow 15 minutes for completion of procedure

Tools required: 7/8" open-end wrench
 NFPA-approved pipe sealant - Megaloc Multipurpose thread
 sealant (stock #15-808) - or equivalent

Repair and/or replacement procedure:

In this procedure, the gas inlet hose will be switched from the Natural Gas (NG) port to the Liquid Propane (LP) port to facilitate the switching from one fuel type to another. Reverse this process if converting from LP to NG.



NOTE: Before starting this procedure, disconnect the gas supply.

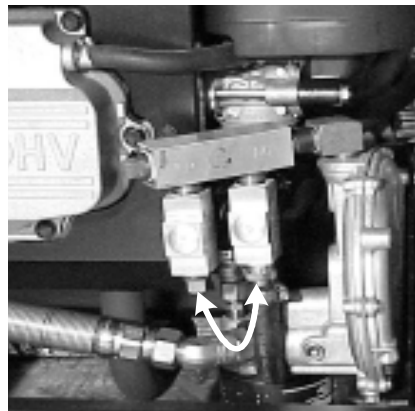

Disconnect and save the sealing plug from the unused fuel port.

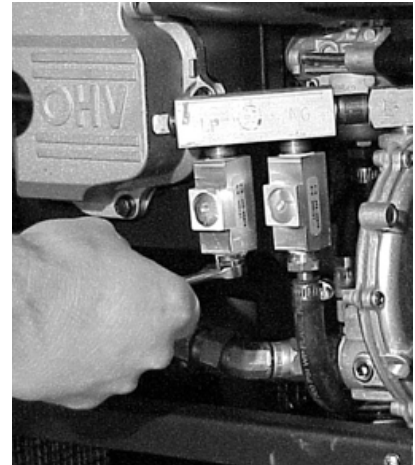

With the gas supply disconnected from the APU, remove the inlet hose from the original gas source.

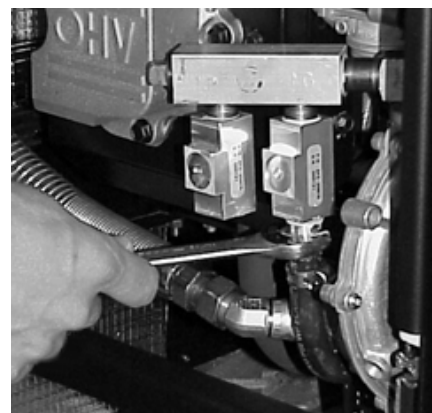

3.10 Fuel Conversion - Natural Gas to LP, *continued*

3.10.2 Dual-Fuel Load Block Conversion, *continued*

Repair and/or replacement procedure:

Coat the fitting with thread sealant. Use only NFPA-approved pipe sealant, i.e., Megaloc Multipurpose thread sealant (stock #15-808) - or equivalent.



Install the fitting in the new fuel port. Install the sealing plug into the now-open port.



NOTE:

Perform the procedure in reverse order if converting the unit from Liquid Propane to Natural Gas.

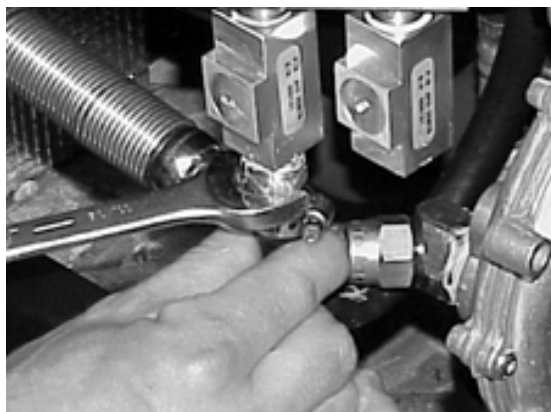

NOTE:

Verify the replacement gas sensor is calibrated to detect the appropriate gas (i.e., Propane or Natural Gas). For further information, contact Alpha Technologies Technical Support at: 1-800-863-3364.

End of Procedure

3. Maintenance

3.11 Fan Replacement Procedure

Allow 5 minutes (per fan) for completion of procedure.

Tools required: Slotted screwdriver
 Digital Volymeter

Repair and/or replacement procedure:



NOTE: Perform this procedure after verifying the presence of correct fan supply voltage (12 VDC). Once the voltage has been verified, remove power from the fan circuit(s) and perform the replacement procedure as outlined below.

1. Open the rear door of the enclosure
2. Disconnect fan wire harness.
3. Use a slotted-head screwdriver to loosen the two captive fasteners at the bottom of the fan and airvane assembly housing.



NOTE: During removal and installation, verify airvane tabs aren't bent or otherwise damaged.

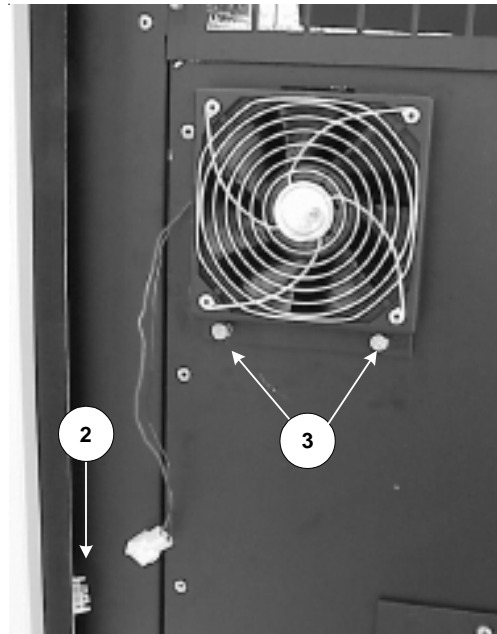

4. Swing lower portion of assembly out.
5. Pull assembly free from opening
6. Replace with functional fan and airvane assembly. Verify tab at top of fan/airvane assembly engages into slot.
7. Tighten captive fasteners.
8. Reconnect fan wire harness.
9. Close rear cabinet door.

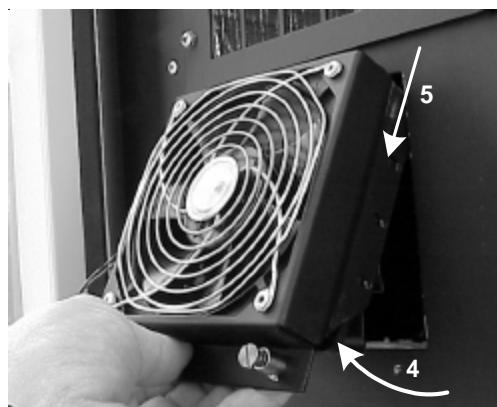

End of Procedure

3.12 Muffler Replacement Procedure

Allow 15 minutes for completion of procedure.

Tools required: #2 Phillips screwdriver or hand drill
1/2" deep-well socket wrench
6" extension
3/8" drive

Removal and replacement procedure:



NOTE: Allow the unit to cool thoroughly before beginning procedure.

1. Remove fastening hardware on muffler access panel.



2. Use the 1/2" deep-well socket to remove the upper flange U-bolt assembly.

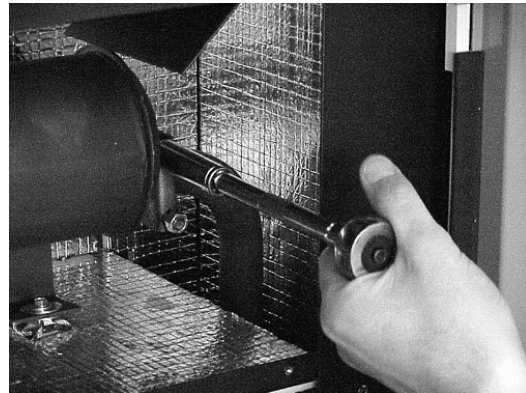

3. Use the 5/16" wrench to remove the "Cable-5 Flexi-mounts". Once the mounting hardware for the "Flexi-mounts" have been removed, the muffler is ready for removal.

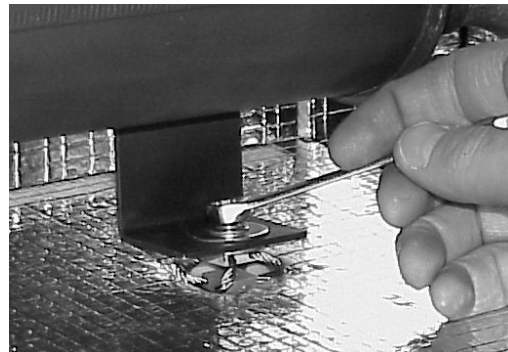

3. Maintenance

3.12 Muffler Replacement Procedure, *continued*

4. Install the new muffler in the housing.



5. Fasten the muffler in place with the "Flexi-mount" hardware. Tighten until clamp and muffler are securely in place.

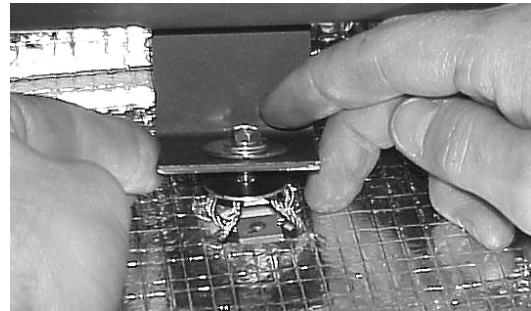

6. Detail of "Flexi-mount". Add anti-seize compound (i.e., Permatex® Antiseize p/n 80209) to bolt threads.

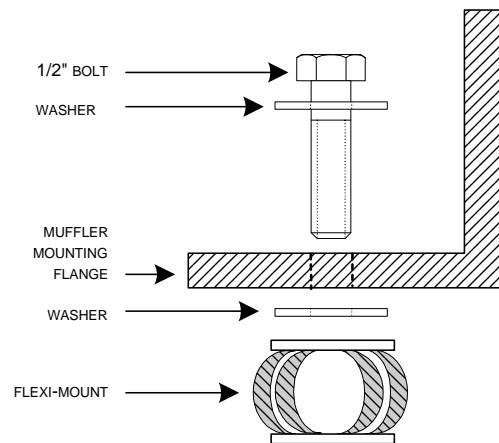

7. Muffler in place - ready to receive upper exhaust pipe; install exhaust pipe and muffler access panel.

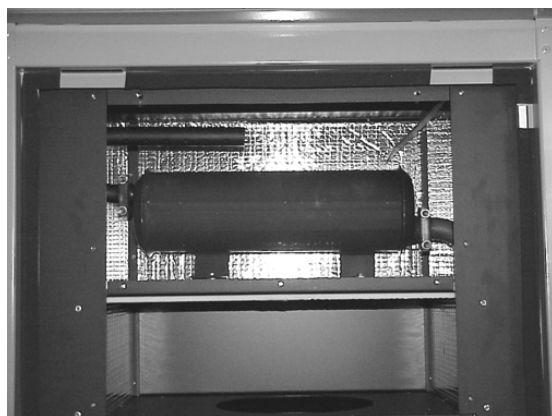

End of Procedure

3.13 Muffler Exhaust Flange Gasket Replacement Procedure



CAUTION: Gasket must be installed properly, or loud improper exhaust operation may exist.



NOTE: Allow the unit to cool thoroughly before beginning procedure.

Allow 15 minutes for completion of procedure.

Tools required: #2 Phillips screwdriver or hand drill
1/2" deep-well socket wrench
6" extension
3/8" drive

Removal and replacement procedure:

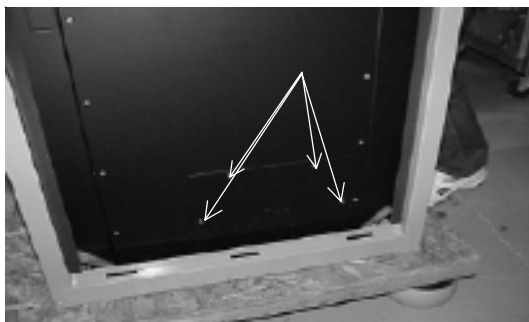

1. Remove rear door of enclosure; locate and remove generator access panel.



2. Use wrenches to loosen muffler flange bolts (2 places).



3. Remove and replace gasket.

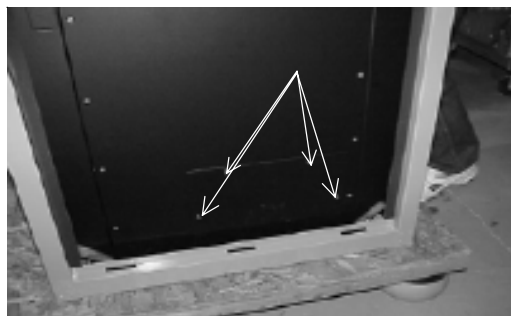

4. Replace generator enclosure access panel and enclosure door.

End of Procedure

3. Maintenance

3.14 Gas Solenoid Replacement Procedure

Allow 45 minutes for completion of procedure.

Tools required: Special Gas Package tool, Alpha p/n 086-134-10, (must be purchased separately)
 3/4" wrench
 Crescent wrench
 Pipe thread compound

Removal and replacement procedure:

1. Shut off or disconnect gas service.
2. Remove Natural Gas pre-regulator or low fuel pressure switch from gas utility box.
3. Use 15/16" wrench to disconnect flex hose.
4. Use crescent wrench or box-end wrench to remove Brass nipple from 3/4" black Iron nipple.



5. Use the special Gas Package tool to remove the 3/4" black Iron nipple from the solenoid. Have an assistant support the Gas Solenoid to prevent breakage of the cast Aluminum assembly.



6. Use a 1/2" box-end wrench to loosen and disconnect mounting bracket u-bolt from Gas Solenoid assembly.
7. Apply an approved compound (i.e., "Megalok") to the 3/4" elbow.
8. Reinstall the elbow into the gas solenoid, and retighten with the special Gas Package tool. Again, provide support for the cast Aluminum body of the solenoid assembly. Upon completion, verify the solenoid is level and the elbow points straight down.



End of Procedure

3.15 Replacing Cabinet Exhaust Duct Upper Seal

Allow 15 minutes for completion of procedure

Tools required: Rubbing Alcohol or similar non-acid-based cleaner
 Scissors

Removal and replacement procedure:

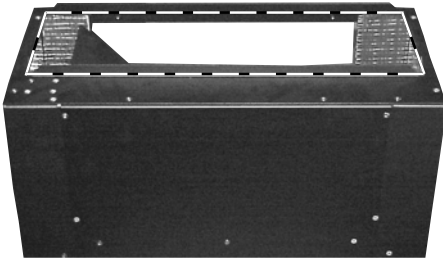

1. Remove old seal and clean duct edge with rubbing alcohol, or other non-acid-based cleaning solution.

2. Peel backing from sealing strip and apply to surface of duct.

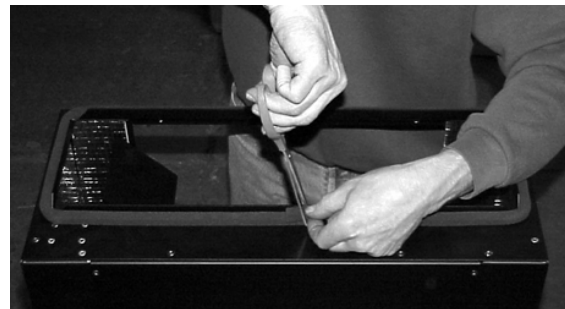
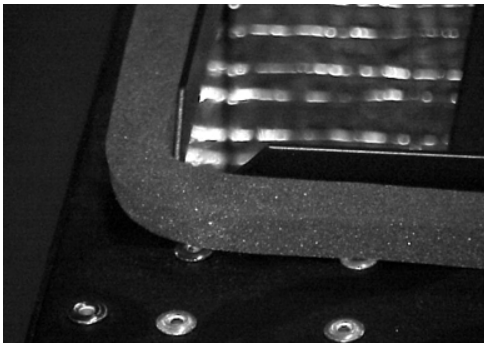

3. Verify sealing material covers the open corners of the duct

4. Trim excess sealing material and replace enclosure.

End of Procedure

3. Maintenance

3.16 Removal and Replacement of Generator Set

Allow 45 minutes for completion of procedure

Tools required: #2 Phillips screwdriver
Crescent wrench
1/4" drive
3/8" drive
7/16" socket

Removal and replacement procedure:

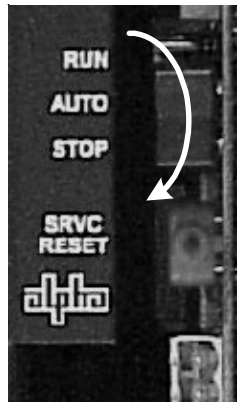

1. Switch ECM to STOP



2. Disconnect all APU connectors and remove APU housing door.

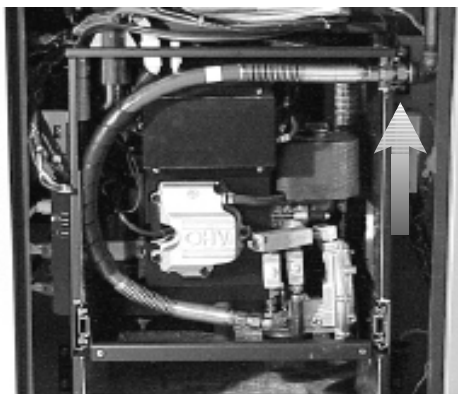

3. Verify Gas OFF and use Crescent wrench to remove upper end of flexible fuel hose.



4. Remove APU slide locking bolt.

3.16 Removal and Replacement of Generator Set, *continued*

Removal and replacement procedure (*continued*):

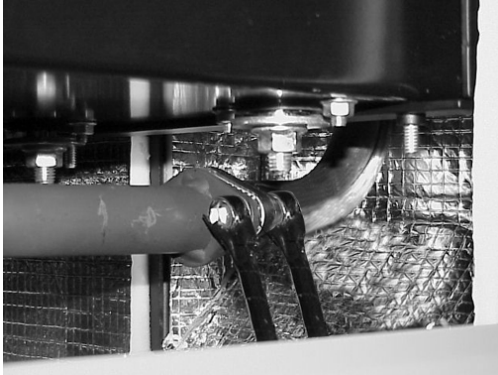

5. Use wrenches to loosen muffler flange bolts (2 places).



6. Pull hose away from interior of APU housing.

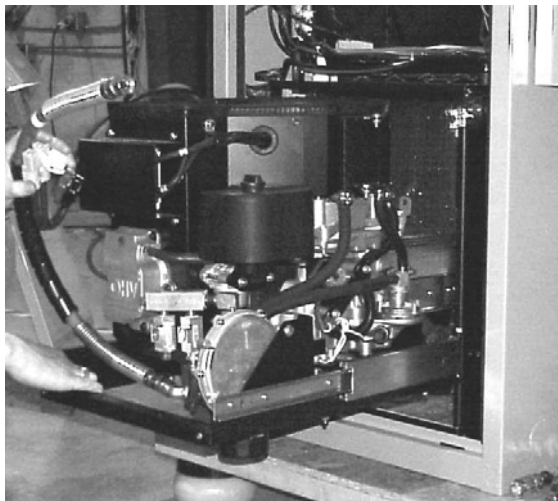

7. Slide APU from housing to its fully extended position, watching for pinch hazards on hoses or electrical wiring.



8. Use 3/8" drive, with 6" extension and 7/16" socket to remove APU mounting bolts (4 places). Utilize two service personnel to then lift the generator set from the slide and set it in a cradle.

3. Maintenance

3.16 Removal and Replacement of Generator Set, *continued*

Removal and replacement procedure (*continued*):

To replace the APU, reverse the steps above, except for special instructions as follows:

To reconnect gas hose, do not use any sealing compounds or gas pipe dope because flare fittings are designed with compression seals that eliminate the need for these sealants.

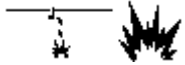

CAUTION: Before performing full test, perform a gas leak test on the flexible hose flare fitting when cranking or running APU using a leak detection solution (30% dish soap in a non-hard water solution). This test **MUST** be performed to comply with NFPA 54 section 4 regarding proper gas leak and pressure tests.

3.17 Maxitrol Pre-Regulator Calibration

Required tools:

- ◆ Screwdriver
- ◆ Gas pressure test kit
- ◆ Approved pipe dope
- ◆ DWYER # 1212 water column (0-16")
- ◆ Allen head ratchet wrench
- ◆ Approved leak detector compound

The Maxitrol regulator has a maximum inlet pressure of 5 PSI. Alpha Technologies recommends all installations range between 0.5-2 PSI for consistency of gas flow.

An external water trap must be supplied outside the enclosure in accordance with local, state, and National Fire Protection Agency (NFPA) codes. Water sent via gas lines to the regulator system could damage the secondary demand regulator. For further details see the CE-G Installation Manual (Alpha p/n 031-089-C0-001).

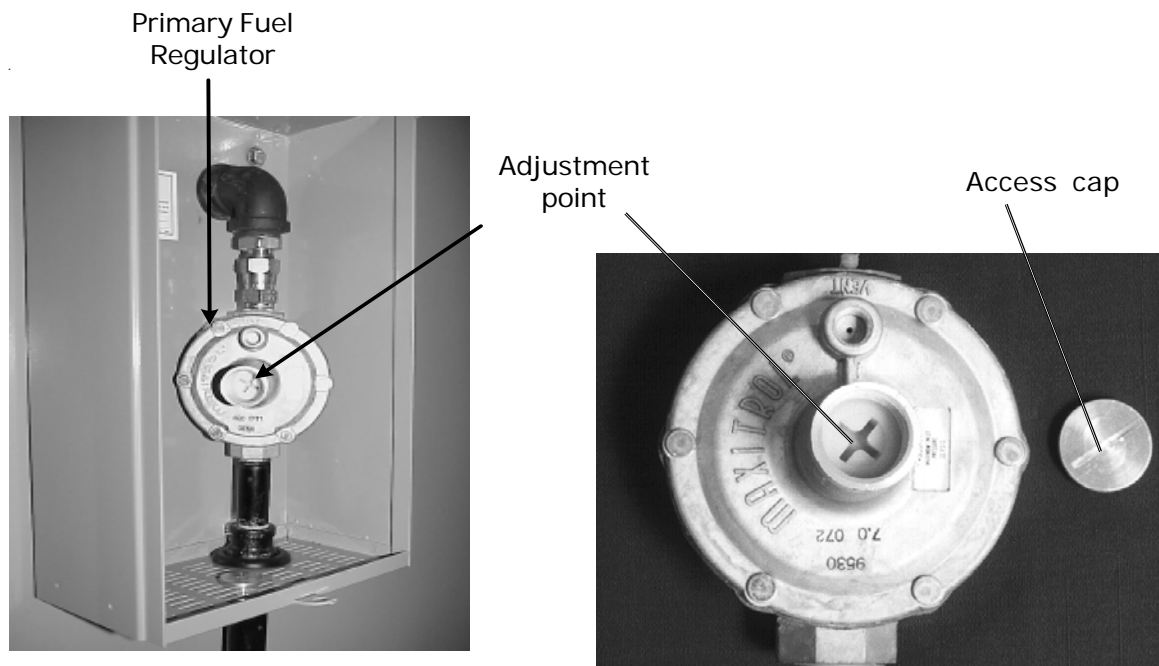

Small DC Systems have the Fuel Shut-off and Primary Regulator located outside the Main Enclosure.

Remove the adjustment cover on the Maxitrol regulator and adjust the screw as indicated in the text. NOTE: Located outside the enclosure in the utility gas box.

Fig. 3-5 Primary Regulator Gas Pressure Adjustment

3. Maintenance

3.17 Maxitrol Pre-Regulator Calibration, *continued*

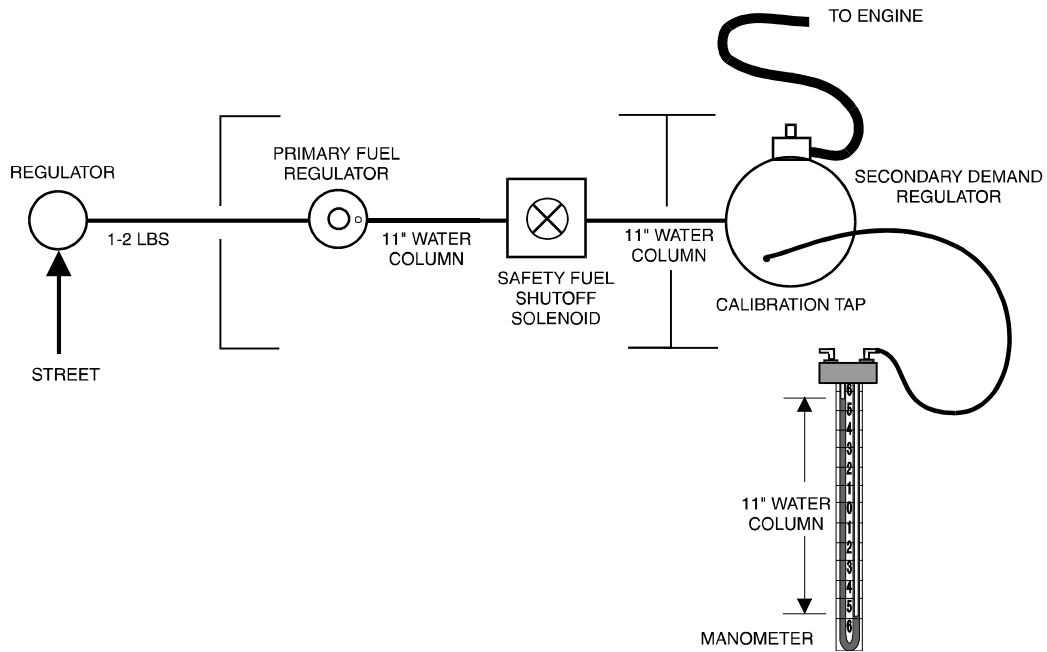

Fig. 3-6 Regulator Calibration Component Arrangement

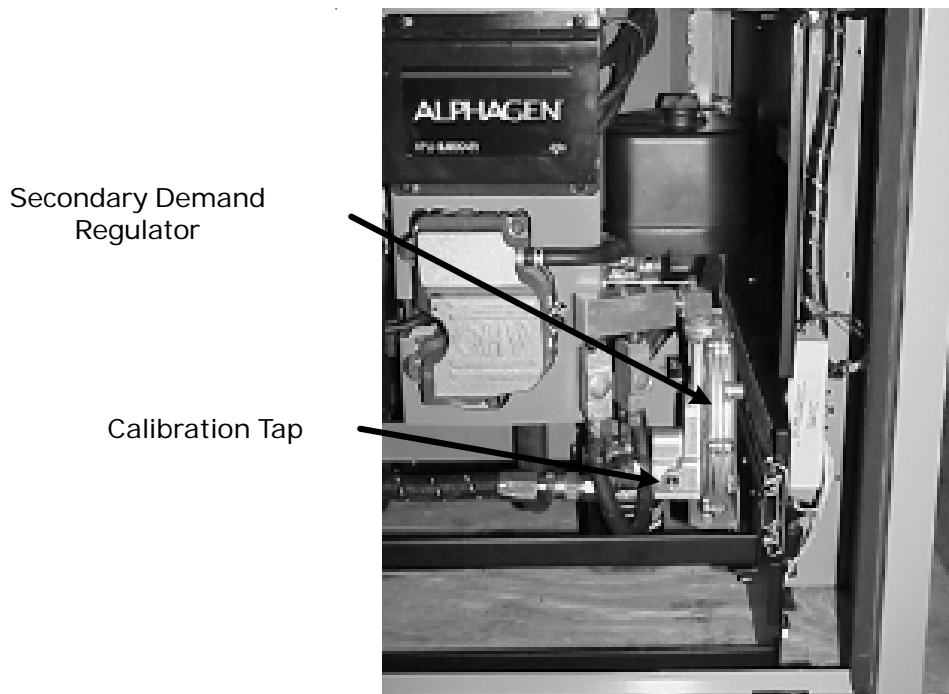

Fig. 3-7 Secondary Regulator Component Location

3.17 Maxitrol Pre-Regulator Calibration, *continued*



NO MATCHES OR OPEN FLAMES:

Use caution whenever working in the area to prevent possible combustion fuel vapors.

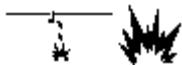

LEAK HAZARD:

Use caution whenever working in the area to prevent and correct any leaks detected.

Calibration Procedure:

1. On the ECM, perform the following:

Set the ECM Run/Auto/Stop (RAS) switch to the STOP position. Remove the Allen-head screw located on the Secondary Demand Regulator.

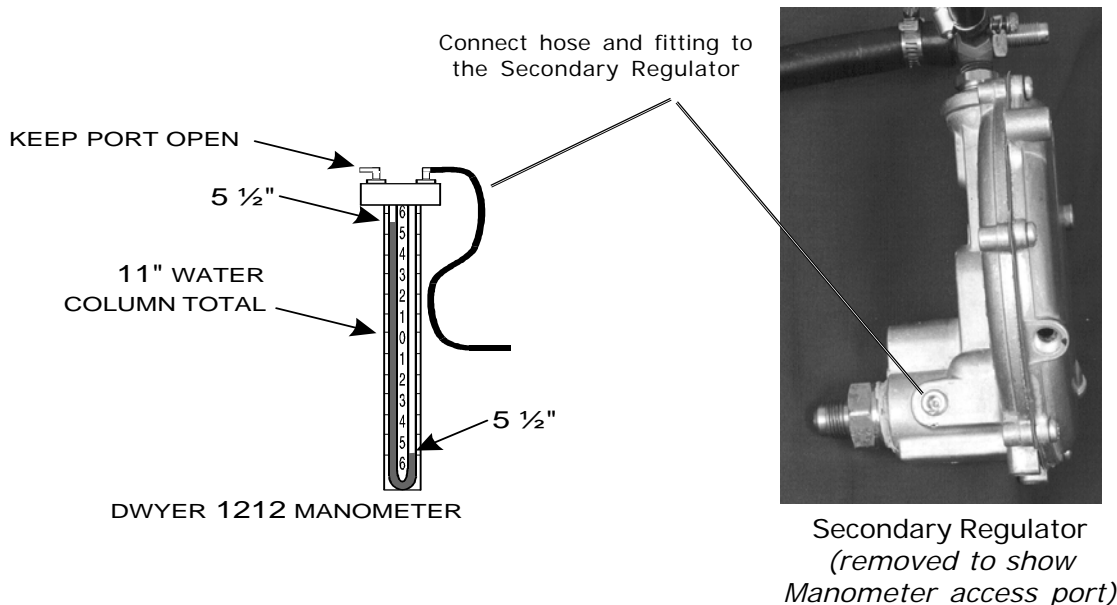

On the DWYER # 1212, perform the following:

2. Open both ports.
3. Set the scale of "0" between the water lines. Connect the pressure test hose (see above).
4. Remove the Maxitrol regulator adjustment cover (*located in the gas service box outside of the enclosure*).
5. Apply 0.5psi-2psi gas pressure to the gas package.
6. Press and hold the ECM's RAS switch in the RUN position until the generator starts. (This may take a few seconds to draw excess air from hoses).



CAUTION: DO NOT CRANK THE STARTER MOTOR MORE THAN 30 SECONDS AT A TIME, AS THIS OPENS THE GAS SOLENOID AND APPLIES GAS PRESSURE TO THE APU!

3. Maintenance

3.17 Maxitrol Pre-Regulator Calibration, *continued*

Calibration Procedure, *continued*

7. Verify the DWYER # 1212 manometer reads 5-1/2" above the "0" mark, and 5-1/2" below the "0" mark. This equals 11" water column of pressure. Adjust the Maxitrol regulator in a clockwise direction to increase pressure, and in a counterclockwise direction to decrease pressure.



CAUTION: DO NOT BOTTOM OUT THE REGULATOR ADJUST SCREW. RETEST THE INLET PRESSURE TO THE MAXITROL GAS PACKAGE.

8. Press and hold the ECM's RAS switch in the STOP position until the generator stops.
9. Disconnect the DWYER # 1212 manometer gas pressure test kit from the Secondary Demand Regulator.
10. Reapply a small amount of an approved propane/natural gas pipe paste to the Allen head cap screw, replace and tighten into the demand regulator.
11. Replace the Maxtrol regulator access cap and gasket, and tighten.

4.1 Alarm Sensor States

The signals from the sensors to the ECM should follow the state table as shown. The signals sent to the status monitoring system are described in the ECM Operator's and Maintenance Manual (Alpha p/n 744-862-B0).

ENGINE SENSORS			
SENSOR	NORMAL STATE	ACTIVE ALARM STATE	ACTION
Low Oil	contact open = oil pressure within tolerance	contact closed = low oil (or engine off)	Latched Shutdown
Oil/Elec Over Temperature	contact open = temp within tolerance (or engine off)	contact closed = overtemp	Dynamic Shutdown
Engine RPM Over Speed	contact open = engine rpm ok (or engine off)	contact closed = engine rpm exceeded	Latched Shutdown
Engine Over Crank	contact open = cranking ok (or engine off)	contact closed = cranking cycles exceeded	Latched Shutdown
Engine Run Status	contact open = Engine off	contact closed = Engine on & RPM is within tolerance	Status Only (Delay 3 sec)
Alternator Overvoltage	N/A Sensed by analog circuit	N/A Sensed by analog circuit	Latched Shutdown
Alternator Output ON	N/A Sensed by analog circuit Developed By Charger Voltage	N/A Sensed by analog circuit Developed By Charger Voltage	Dynamic Status Signal
Switch Not In Auto	contact closed =	contact open =	Dynamic Status Signal
Low Ignition battery	NA Sensed by analog circuit	NA	Dynamic Status Signal
ENCLOSURE SENSORS			
SENSOR	NORMAL STATE	ACTIVE ALARM STATE	ACTION
Gas Hazard	contact closed = no gas present	contact open = Gas present, sensor fail, or 12v supply fail	Latched Shutdown
Pad Shear	contact open = correct position	contact closed = pad shear	Latched Shutdown
Water Intrusion	contact closed = no water present	contact open = water rise	Dynamic Shutdown
Low Fuel Gas Pressure	contact open = gas pressure ok > 5" water column	contact closed = low gas pressure < 5" water column	Dynamic Shutdown 5 min return
Door Open (Tamper)	contact open = door closed	contact closed = door is open	Dynamic Status Signal

Table 4-1 Sensor Signal State Table

4. Interconnection

4.2 ECM Interface Topology and Connectors

The ECM PWR- GRI PCBA provides the interface between cabinet sensors, APU control, and power conditioning to the ECM. The interface also supplies all the necessary signals, alarms, logic power, and analog voltages required for telemetry to the cable head end, central office, or network manager, and allows the Alpha Systems control module to start and stop the Engine alternator as part of network controlled periodic tests and exercises.

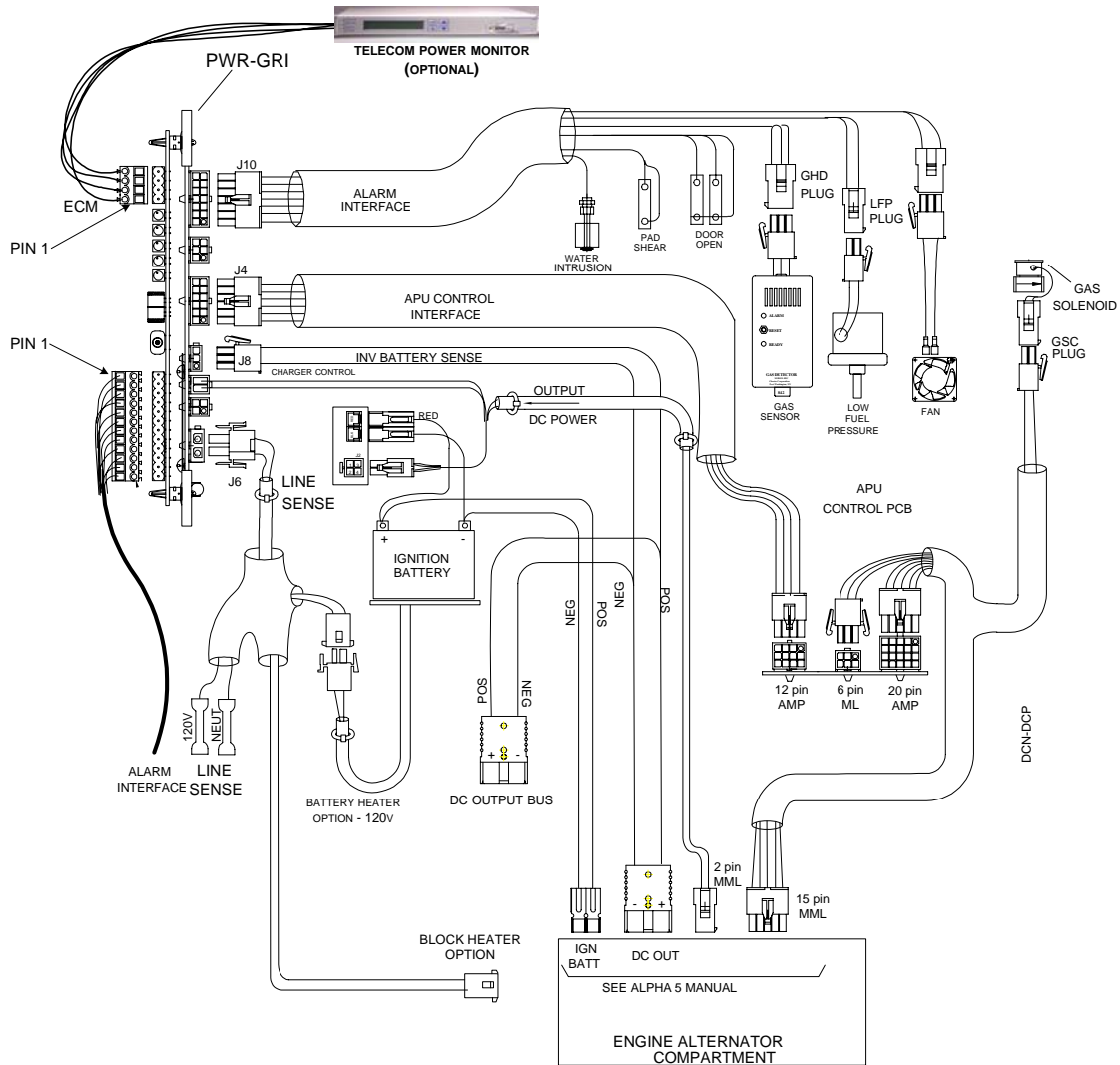

Fig. 4-1 ECM/APU Interconnection

4.3 Connectors

4.3.1 Gas Hazard Alarm Interface

The Gas Hazard Detector Interface Connector is connected between the wire harness and detector unit as shown. The interface control is a 3-pin (1x3 row) Universal Mini Mate-'N'-Lok style male connector. See Fig. 4.1 for location.

Pin	Description	Function
1	Gas Hazard Sensor Switch	Active OPEN signal denotes Gas Hazard (Logic HIGH)
2	Gas Hazard Power/Alarm Common	Return signal path for sensor
3	Gas Hazard Logic Power +12VDC	Fused Logic Power for Logic PCB & sensor

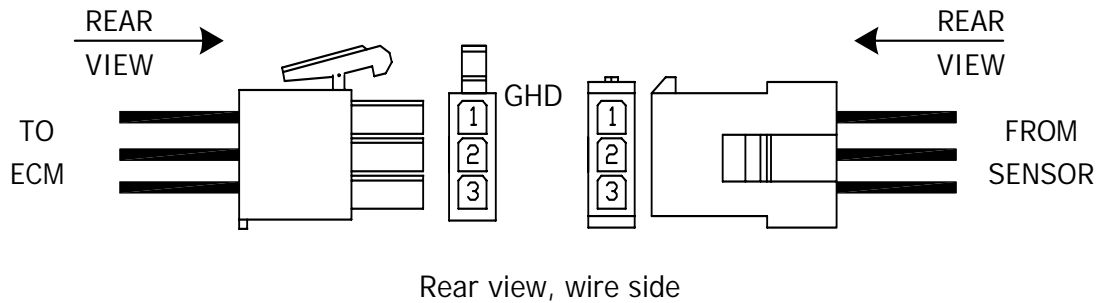

Fig. 4-2 Gas Hazard Detector Interface

4. Interconnection

4.3 Connectors, *continued*

4.3.2 Low Fuel Pressure Interface Connector

The interface control is a 2 pin Mini Mate N' Lok connector (Near gas solenoid). See Fig. 4.1 for location.

Pin 1 = +12VDC activates (opens) solenoid ONLY when APU is running.

Controlled by APU engine ON command.

Pin 2 = Solenoid common (negative) connection.

Pin#	Description	Function
1	Low Fuel Pressure Sensor Contact	CLOSED (LOW signal) denotes Low Fuel Pressure (LPV Versions only)
2	Low Fuel Pressure Common	Return signal path for sensor

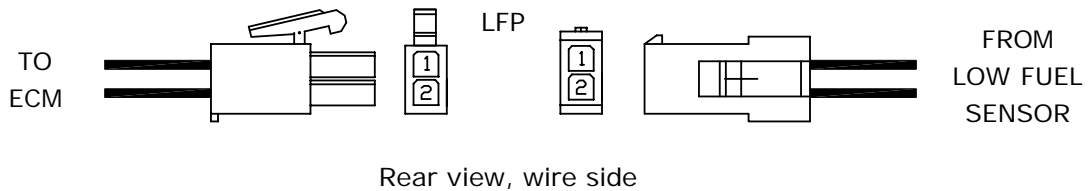

Fig. 4-3 Low Fuel Pressure Switch Interface

4.3 Connectors, *continued*

4.3.3 Solenoid (See Fig. 4.1 for location)

Pin #	Description	Function
1	Gas Solenoid +12V	+12VDC supplied to Gas Solenoid only when APU is ON (Running). APU Shuts OFF gas supply to cabinet during any fail safe or fault condition.
2	Gas Solenoid Common	Return path for Gas Solenoid

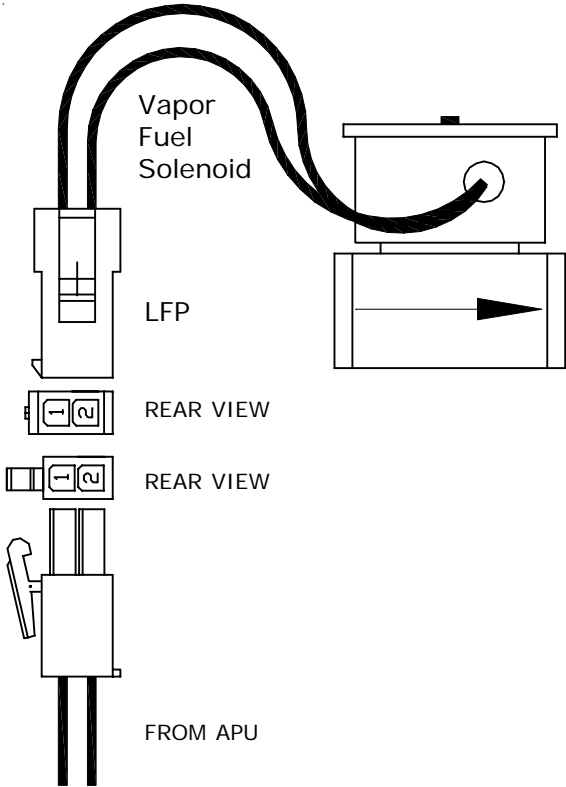

Fig. 4-4 Gas Solenoid Interface Connector

4. Interconnection

4.3 Connectors, *continued*

4.3.4 Charger Module – Control Interface Connector

The Charger Module – Control Interface Connector is connected between the charger module and ECM with Sense/Power leads connected to the APU Output DC Bus. The interface control is a 4-pin (2x2 row) Universal Mini Mate-'N'-Lok style male connector. See Fig. 4.1 for location.

Pin#	Description	Function
1	ECM Charger Control (YELLOW) wire.	ECM Turns charger ON by connecting this to Pin 3 with a relay on the ECM PCBA.
2	Inverter Battery (+) RED wire.	Input power to charger module, operates on 36 or 48VDC battery packs to charge ignition battery.
3	ECM Charger Control (ORANGE) wire.	ECM Turns charger ON by connecting this to Pin 1 with a relay on the ECM PCBA.
4	Inverter Battery NEGATIVE BLACK wire	NEGATIVE Input power to charger module, operates on 36 or 48VDC battery packs to charge ignition battery.

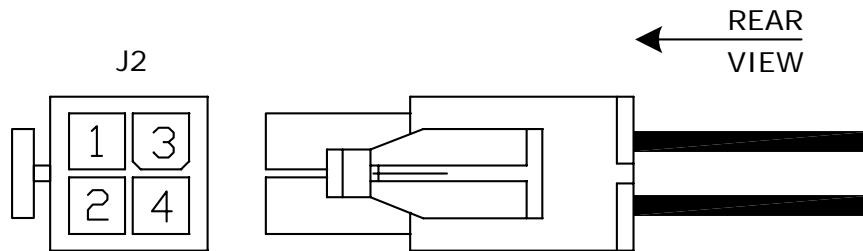

Fig. 4-5 Charger Control Interface

4.3 Connectors, *continued*

4.3.5 Charger Module - Output Interface Connector

The Charger Output Interface Connector (J1) is connected between the charger module and the Ignition Battery as shown. The interface control is a 2-pole Anderson connector. See Fig. 4.1 for location.

Pole	Description	Function
RED	Charger Output POSITIVE	To Ignition battery Positive post
BLK	Charger Output NEGATIVE	To Ignition battery Negative post

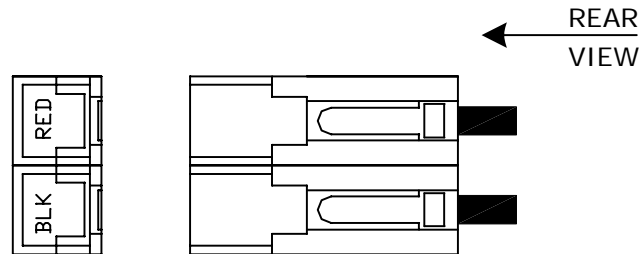

Fig. 4-6 Charger Output Interface

4. Interconnection

4.3 Connectors, *continued*

4.3.6 APU Ignition Battery Interface Connector

The interface control is a 2-pole Anderson connector:

Pin 1 = +12VDC activates (opens) solenoid ONLY when APU is running.
Controlled by APU engine ON command)

Pin 2 = Solenoid common (negative) connection.

See Fig. 4.1 for location.

Pole	Description	Function
RED	Ignition Battery POSITIVE	To Ignition battery Positive post – APU Starter connection
BLK	Ignition Battery NEGATIVE	To Ignition battery Negative post – APU Chassis Ground

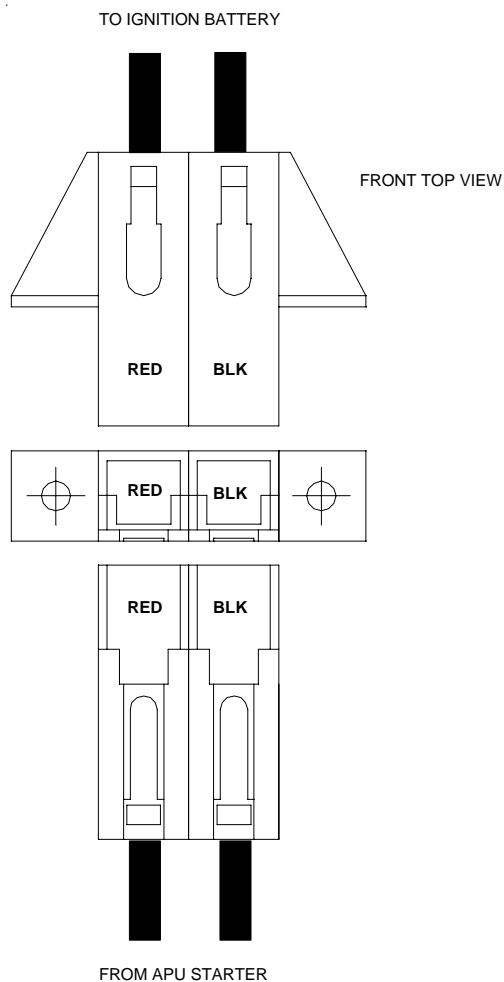

Fig. 4-7 APU Ignition Battery Connector

4.3 Connectors, *continued*

4.3.7 Alarm Control Interface/APU Interface Connector (APU-I/O)

The interface control is a 12 pin (3x4 row) Mini Mate-'N'Lok style connector. See Fig. 4.1 for location.

Pin#	Description	Function
1	+12V Ignition Battery	Ignition battery Fused 12V from APU.
2	Neg Ignition Battery	Ignition Battery Negative from APU.
3	Low Oil Pressure	Active LOW signal denotes Low Oil Pressure.
4	Over-Temp	Active LOW signal indicates Over Temp.
5	Start Command	Active LOW from ECM activates the APU START relay.
6	Common (Start /Stop)	Common return between Start and Stop relays.
7	Stop Command	Active LOW from ECM activates the APU STOP relay.
8	Over-Speed	Active LOW signal denotes engine RPM was exceeded.
9	Over-Crank	Active LOW signal denotes Over Crank Limit is reached.
10	Engine Run	Active LOW signal denotes the Engine is Running.
11	Not Used	
12	Not Used	

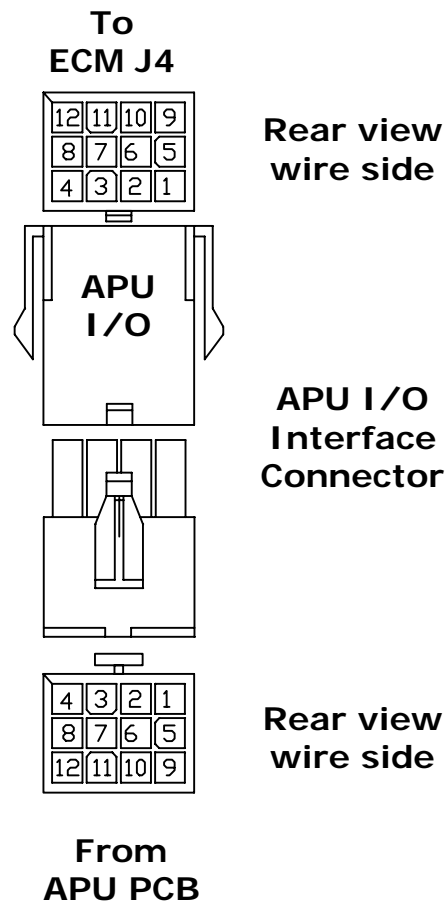

Fig. 4-8 Alarm Control Interface Connector

4. Interconnection

4.3 Connectors, *continued*

4.3.8 ECM PWR-GRI Interface

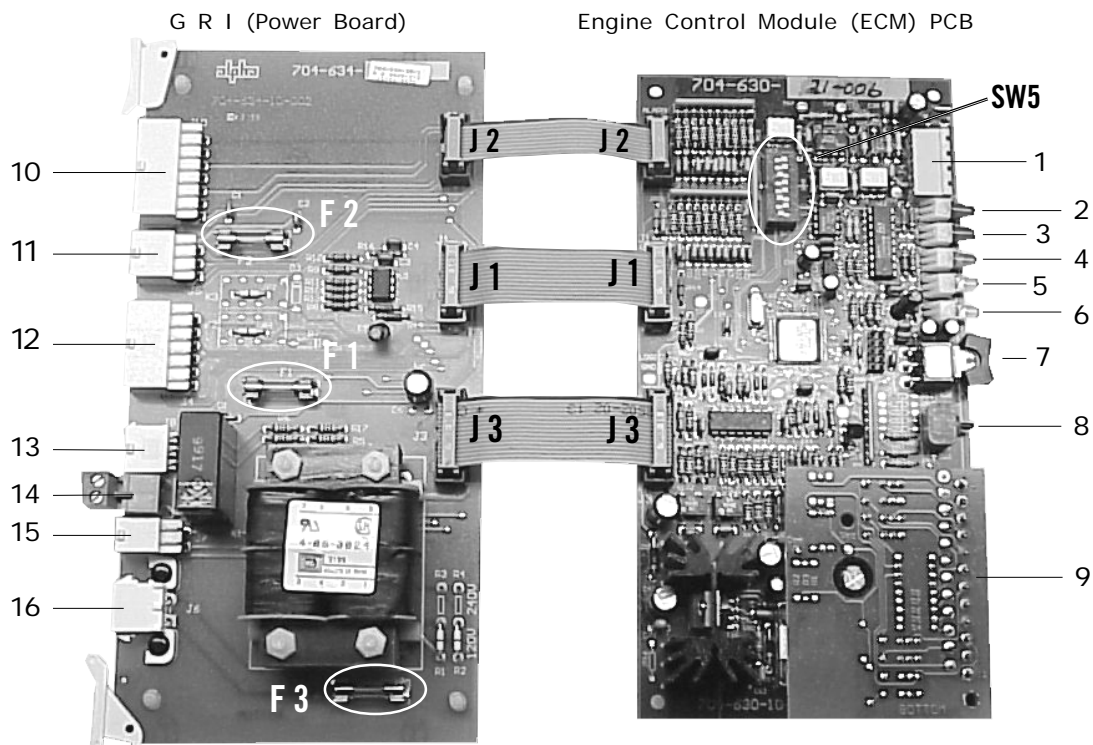

Fig.4-9 ECM Printed Circuit Boards

Engine Control Module LED Indicators and switches:

1. Communications Input (J4) **Note: Pin #1 at bottom of connector.**
2. "Major" Alarm Indicator (Red LED)
3. "Minor" Alarm Indicator (Red LED)
4. "Notify" Indicator (Orange LED)
5. "Comm" Indicator (Green LED)
6. "System" Indicator (Green LED)
7. "Run-Auto-Stop" switch
8. "Service/Reset" Push button switch (SW3)
9. Transponder Interface (J6) **Note: Pin #1 at top of connector.**

GRI Power Board Connectors:

10. Enclosure Alarm Input connector (J10)
11. Fuel Enclosure Alarm connector (J5)
12. Interface Input connector from APU (J4)
13. Inverter battery string connector (J8)
14. Battery Charger Control Interface
15. AC generator Voltage, Current connector (J7)
16. AC Line Input connector (J6) - Connected at all times

Fuses and Switches:

- | | |
|-----|--|
| F1 | 1.5A, 250V (Slo-Blo) Alpha p/n 460-204-10 |
| F2 | 1.0A, 250V (Slo-Blo) Alpha p/n 460-205-10 |
| F3 | 250mA, 250V (Slo-Blo) Alpha p/n 460-166-10 |
| SW5 | Configuration DIP switch |

4.3 Connectors, *continued*

4.3.9 ECM-PWR GRI Enclosure Sensor Interface Ribbon Cable

The connector is a 14 pin 0.100" spaced, 150V rated ribbon cable with polarized cable connectors that prevent incorrect connections in the field. Designations for the connector mounted on the PCBA shall be identified by silk screen "J1" and marked with the #1 pin of the PCB receptacle for polarization. See Fig. 4.9 for location.

Pin	Description
1	Low Oil Pressure*
2	Over-Temp*
3	Over-Speed*
4	Over-Crank*
5	Engine Run*
6	Over Voltage Shutdown*
7	Alternator Output Active (ON)* (Developed by Charger Circuit)
8	Switch Not In Auto* (Auto-Off-Manual switch control switch)
9	Low Ignition Battery*
10	Logic Common - all alarms listed above
11	Control RTY* (Relay Transfer Switch low = Generator AC power) (Referenced to pin 13)
12	Start* and Engine Run Enable* (See below) (Also remote test from external test routine)
13	Start/Stop Power Common
14	Stop* (To Stop APU after test is complete)

Note: Active low determined by (*) symbol.

Note: The Pin #12 serves two functions:

- Collocated operation with ACU, START* command causes the engine to latch on and continue to run when START* is released.
- Remote operation with ECM, ENGINE RUN ENABLE* (Pin 12) command enables the engine to run as long as the signal is held active LOW, and shuts down when the ENGINE RUN ENABLE* is released.

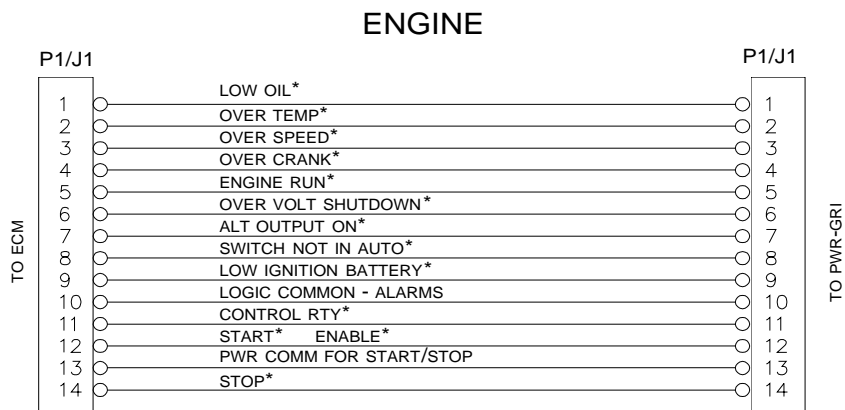

Fig. 4-10 ECM-PWR GRI Enclosure Sensor Interface Ribbon Cable

4. Interconnection

4.3 Connectors, *continued*

4.3.10 ECM and PWR-GRI Interface Ribbon Cable

This connector is a 10 pin 0.100" spaced, 150V rated ribbon cable with polarized cable connectors that prevent incorrect connections in the field. Designations for the connector mounted on the PCBA shall be identified by silk screen "J2" and marked with the #1 pin of the PCB receptacle for polarization. See Fig. 4.9 for location.

Pin	Description	Function
1	Gas Hazard*	
2	Pad Shear*	
3	Water Intrusion*	
4	Low Gas Pressure*	
5	Door Open*	(Does not disable APU RUN operation, alarms only)
6	FE Gas Hazard*	(External Fuel Enclosure)
7	FE Pad Shear*	(External Fuel Enclosure)
8	FE Low Gas Pres*	(External Fuel Enclosure)
9	FE Door Open*	(External Fuel Enclosure)
10	Logic Common	

Logic Common - Enclosure sensors
 Note: Active low determined by (*) symbol.

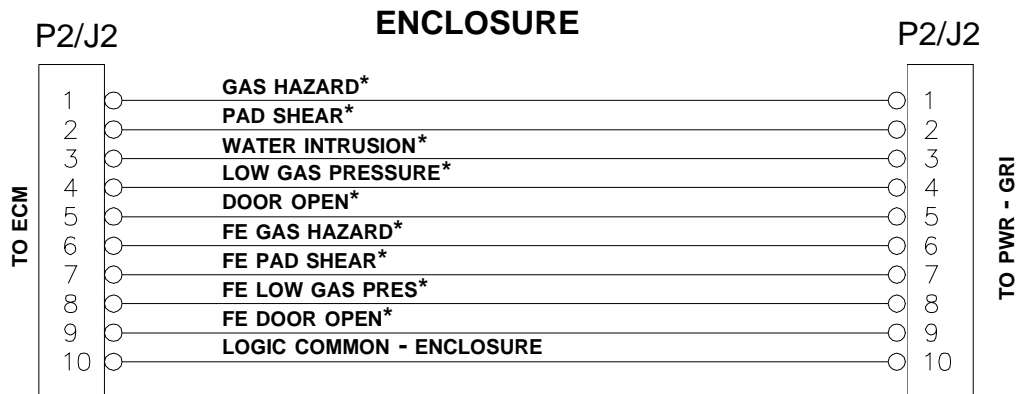

Fig.4-11 ECM and PWR-GRI Interface Ribbon Cable

4.3 Connectors, *continued*

4.3.11 Analog and Logic Power Interface Ribbon Cable

This connector is a 16 pin 0.100" spaced, 150V rated ribbon cable with polarized cable connectors that prevent incorrect connections in the field. Designations for the connector mounted on the PCBA shall be identified by silk screen "J3" and marked with the #1 pin of the PCB receptacle for polarization. See Fig. 4.9 for location.

Pin	Description	Function
1	Ign +12VDC RAW DC	(Fused @1Amp Slow Blow Ignition Battery)
2	Ign +12VDC RAW DC	(Fused @1Amp Slow Blow Ignition Battery)
3	Ign 12v Common Return	(For 12V RAW)
4	Ign 12v Common Return	(For 12V RAW)
5	Logic Common Return	(For digital and micro power)
6	Logic Common Return	(For digital and micro power)
7	Analog Common Return	(For AC & DC Sense circuits)
8	Analog Common Return	(For AC & DC Sense circuits)
9	Scaled Inverter Bus Pos	(Inverter Battery Bus Pos) (125VDC=5.0VDC scale)
10	Spare	
11	Scaled AC Line Input L1	(Line AC Output 16vac)
12	Scaled AC Line Input L2	(Line AC Output 16vac)
13	Scaled AC Gen Output L1	(Gen AC Output 16vac)
14	Scaled AC Gen Output L2	(Gen AC Output 16vac)
15	Out CT POS	(Gen AC Output Current Transformer)
16	Out CT NEG	(Gen AC Output Current Transformer)

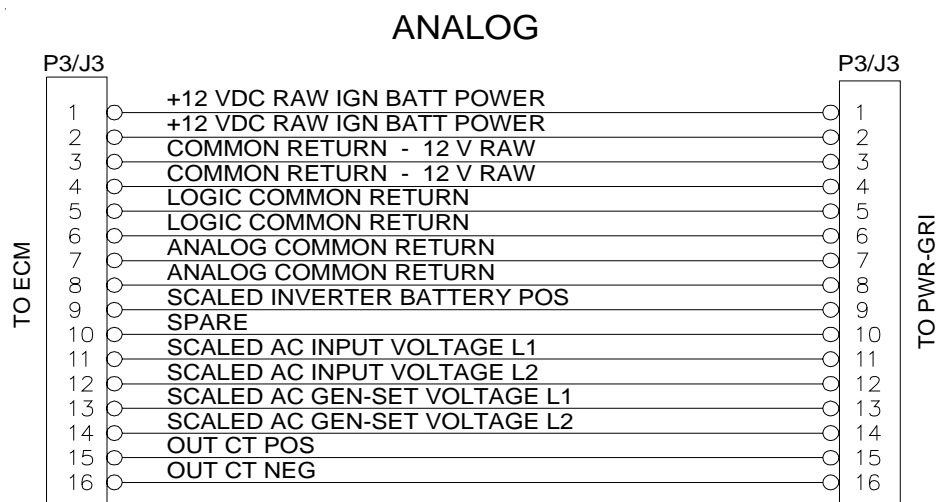

Fig.4-12 Analog/Logic Power Interface connection

4. Interconnection

4.3 Connectors, *continued*

4.3.12 ECM - Enclosure Alarm Interface

The Alarm Interface Connector (J10) connected to the Power PCBA as shown. The interface control is a 14-pin (2x7 row) Universal Mini Mate-'N'-Lok style male connector. See Fig. 4.9, item 10 for location.

Pin	Description	Function
1	Water Intrusion Sensor Intrusion	Contact OPEN (HIGH signal) denotes Water
2	Water Intrusion common	Return signal path for sensor
3	Pad Shear Sensor	Contact CLOSED (LOW signal) denotes Pad Shear
4	Pad Shear Common	Return signal path for sensor
5	Low Fuel Pressure Sensor	Contact CLOSED (LOW signal) denotes Low Fuel Pressure (LPV Versions only)
6	Low Fuel Pressure Common	Return signal path for sensor
7	Gas Hazard Sensor Switch	Active OPEN signal denotes Gas Hazard (Logic HIGH)
8	Gas Hazard Power/Alarm (Common)	Return signal path for sensor
9	Gas Hazard Logic Power (+12VDC Fused)	Logic Power for Logic PCB & sensor
10	Door Open Sensor	Contact CLOSED (LOW signal) denotes Door is OPEN
11	Door Open Common	Return signal path for sensor
12	No Connection	
13	Cabinet Fan +12V Fused	+12VDC supplied to Fan – non-switched
14	Cabinet Fan Common	Return path for Fan

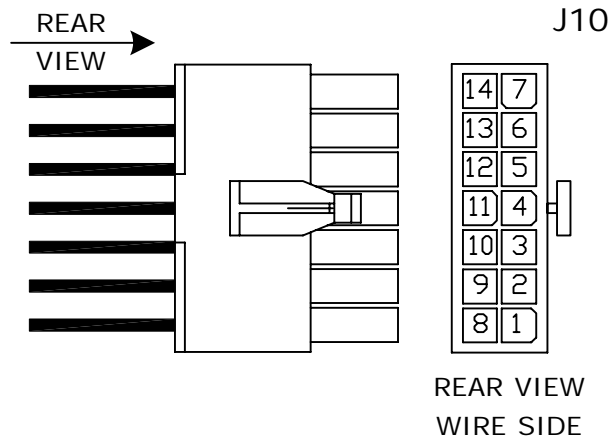

Fig.4-13 Enclosure Alarm Interface

4.3 Connectors, *continued*

4.3.13 DC Bus Sense Interface Connector

ECM - DC Bus Sense Interface Connector J8. See Fig. 4.9, item 13 for location.

The interface control is a 3-pin (1x3 row) Mini Mate-'N'-Lok style connector.

Pin	Description	Function
1	DC Bus Sense (POS.)	Output DC battery bus – positive connection
2	No Connection	
3	DC Bus Sense (NEG.)	Output DC battery bus – positive connection

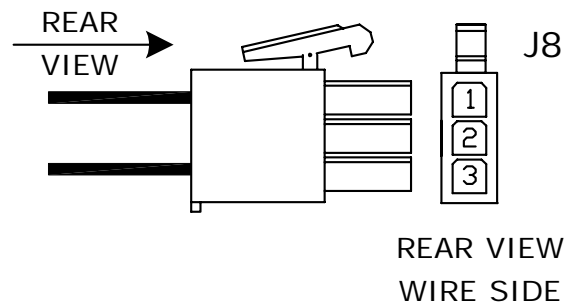

Fig.4-14 DC Bus Sense

4. Interconnection

4.3 Connectors, *continued*

4.3.14 Charger Control Interface Connector

The Charger Control Interface Connector is connected between the charger module and ECM as shown. The interface control is a 2-position terminal block. See Fig. 4-9, item 14 for location.

Pin	Description	Function
1	Control 1	This control connects pin 1 & 2 together, thereby turning the Charger ON, I.E. CLOSED (LOW signal)
2	Control 2	Charger control common return



NOTE: The ECM will turn the charger either ON or OFF depending upon ignition battery charge, temperature, and battery bus voltage.

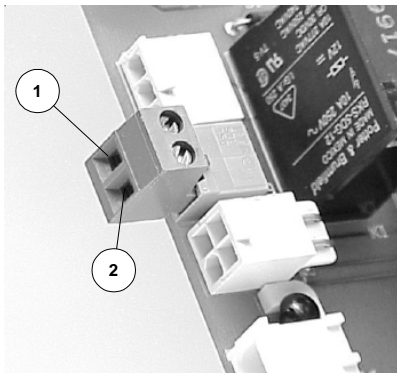

Fig.4-15 Charger Control Interface Connector

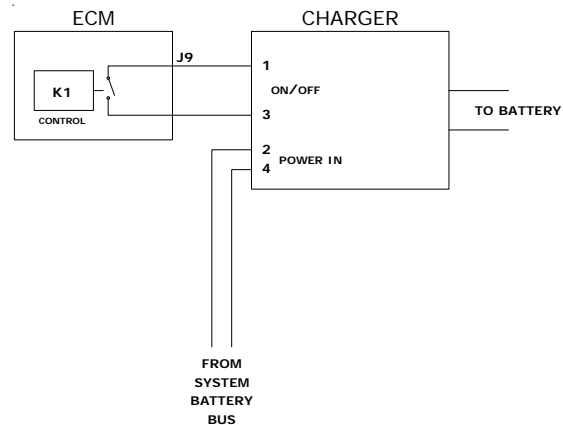
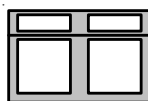

Fig.4-16 Simplified block diagram
Charger Control Interface Connector



NOTE: Previous versions used a push-terminal style connector:



(Front view, wire side)

4.3 Connectors, *continued*

4.3.15 ECM - APU Control Interface

The interface control is a 12-pin (2x6 row) Mini Mate-'N'-Lok style connector. See Fig. 4.9, item 12 for location.

Pin	Description	Function
1	+12V Ignition Battery	Ignition battery Fused 12V from APU
2	Neg Ignition Battery	Ignition Battery Negative from APU
3	Low Oil Pressure	Active LOW signal denotes Low Oil Pressure.
4	Over-Temp	Active LOW signal indicates Over-Temp.
5	Start Command	Active LOW from ECM activates APU START relay.
6	Common (Start – Stop)	Common return between Start and Stop relays.
7	Stop Command	Active LOW from ECM activates APU STOP relay.
8	Over-Speed	Active LOW signal denotes engine RPM was exceeded.
9	Over-Crank	Active LOW signal denotes Over Crank Limit is reached.
10	Engine Run	Active LOW signal denotes the Engine is running.
11	Not Used	
12	Not Used	

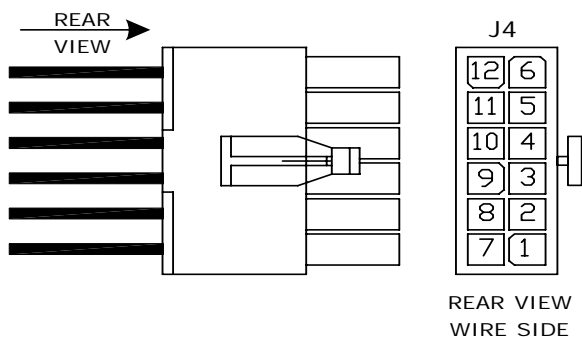

Fig.4-17 APU Control Interface

4. Interconnection

4.3 Connectors, *continued*

4.3.16 ECM - AC Sense 120V Interface

The interface control (J6) is a 2-pin (1x2 row) Mini Mate-'N'-Lok style connector. See Fig. 4-9, item 16 for location.

Pin	Description	Function
1	Line 1, 120VAC AC Sense	The Line side that powers the ECM and Power PCB, and provide AC line sense to start the APU
2	Line 2, Neutral	The Neutral side the incoming line power.

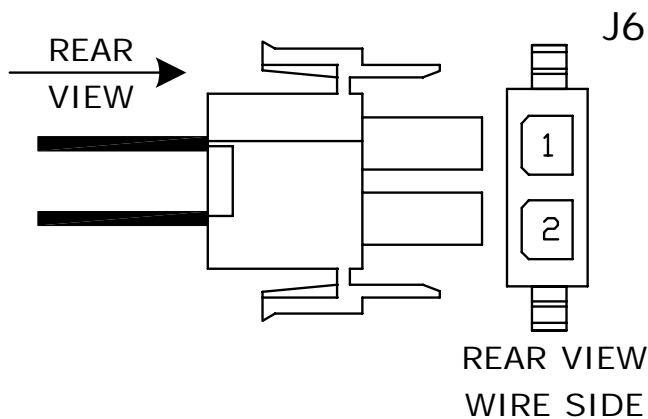
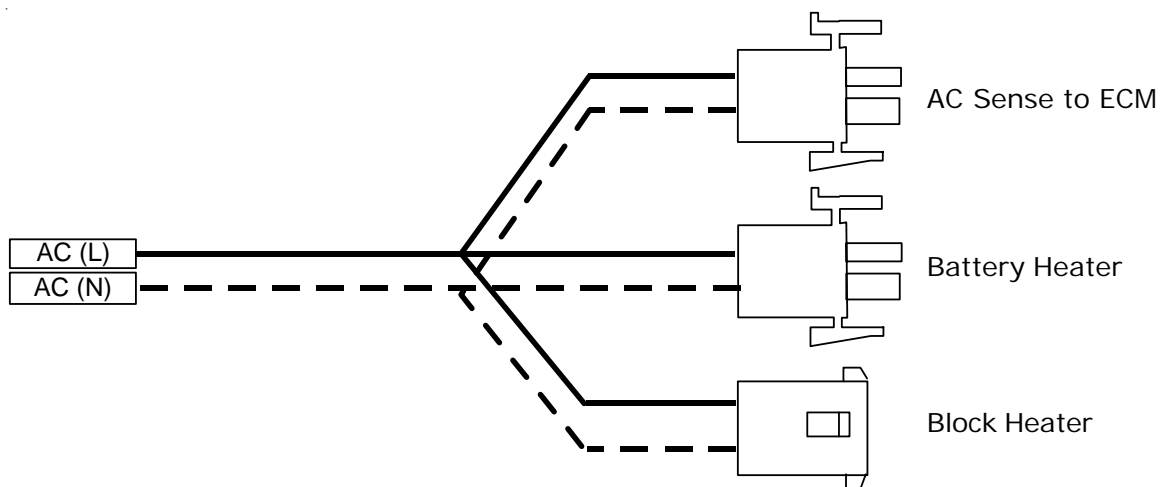

Fig.4-18 AC Sense, 120/240V Interface



4.3 Connectors, *continued*

4.3.17 ECM - Alarm Interface & Communications

The Alarm output interface and communications connectors are referenced and described in *Section 3.4, Transponder Interconnection*, of the ECM Operators manual (Alpha p/n 744-862-C0). See Fig. 4-9, items 1 and 9 for location. For RS-485 interface connection, please refer to *Section 2., Installation*, in the Telecom Power Monitor (TPM) Operator's Manual (p/n 017-913-B0).

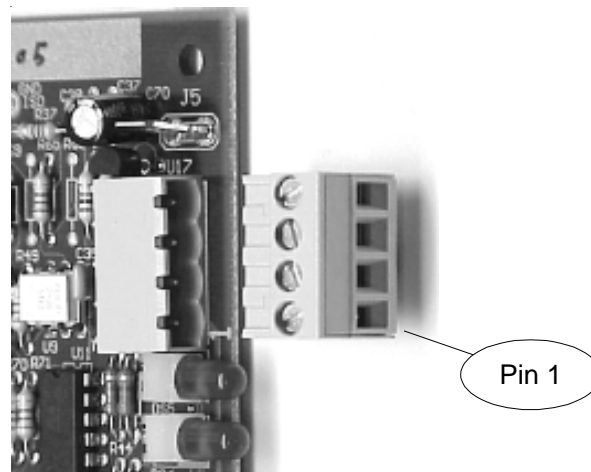

Fig.4-19 RS-485 Communications Input Connector
See Fig. 4-9, item 1 for location.

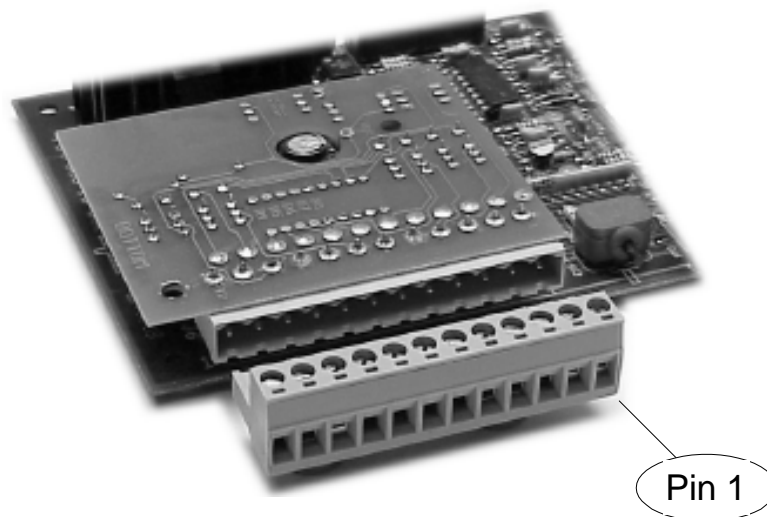

Fig.4-20 Transponder Interface Connector
See Fig. 4-9, item 9 for location.

4. Interconnection

4.3 Connectors, *continued*

4.3.18 ECM Parallel Transponder Interface

The Telecom version of the ECM has a relay board is built onto the ECM microboard. The alarm outputs of the ECM are remapped, and the pinout and alarm signal descriptions are shown in the table below:

PIN	ALARM SIGNAL DESCRIPTION	ACTIVE STATE
1	Engine Run Common	
2	Engine Run	Closed on alarm w/respect to pin 1
3	Engine Run	Open on alarm w/respect to pin 1
4	Major Alarm Common	
5	Major Alarm	Closed on alarm w/respect to pin 4
6	Major Alarm	Open on alarm w/respect to pin 4
7	Minor Alarm Common	
8	Minor Alarm	Closed on alarm w/respect to pin 7
9	Minor Alarm	Open on alarm w/respect to pin 7
10	Door Intrusion Common	
11	Door Intrusion	Open on alarm w/respect to pin 10
12	Door Intrusion	Closed on alarm w/respect to pin 10

Table 4-2, ECM parallel Transponder interface



NOTE: Pin 1 is oriented to the TOP of the board.

[Power]

Investigate the [Power] of Alpha @ www.alpha.com 

UNITED STATES
ASIA PACIFIC
LATIN AMERICA
Alpha Technologies
3767 Alpha Way
Bellingham, WA 98226
Tel: (360) 647-2360
Fax: (360) 671-4936
Web: www.alpha.com

CANADA
Alpha Technologies
7033 Antrim Ave.
Burnaby, B.C. V5J 4M5
Tel: (604) 430-1476
Fax: (604) 430-8908

UNITED KINGDOM
Alpha Technologies
Cartel Business Estate
Edinburgh Way
Harlow, Essex CM20 2DU
Tel: +44-1279-422110
Fax: +44-1279-423355

GERMANY
Alpha Technologies
Hansastrasse 8
D-91126 Schwabach
Tel: +49-9122-997303
Fax: +49-9122-997321

MIDDLE EAST
Alphatec
P.O. Box 6468
3307 Limassol, Cyprus
Tel: +357-5-375675
Fax: +357-5-359595

AUSTRALIA
Alpha Technologies
8 Anella Ave., Unit 6
Castle Hill, NSW 2154
Tel: +61 (0)2 9894-7866
Fax: +61 (0)2 9894-0234

Due to continuing product improvements, Alpha reserves the right to change specifications without notice.
Copyright © 2000 Alpha Technologies, Inc. All rights reserved. Alpha is a registered trademark of Alpha Technologies. 031-099-B4-02 Rev.C.