

 **WARNING!**

Verify the fuel and oil tanks are empty prior to installing the wheel/handle kit. Refer to the Honda engine owner's manual for details. If the fuel and oil tanks are not empty, raise the generator and provide adequate support before performing the installation.

Tools required:

- 10mm socket
- 12mm socket
- 7/16" socket for handle
- 6" extension
- 3/4" socket drive
- #2 Phillips screwdriver

To attach the Front Foot Bracket and Wheel Assembly:

1. Tilt unit up on the control panel end.
2. Use 12mm socket to remove hardware from front and rear foot brackets. Keep hardware for steps 3 and 4.
3. Replace front bracket with angled bracket as shown.
4. Install wheel bracket assembly as shown.

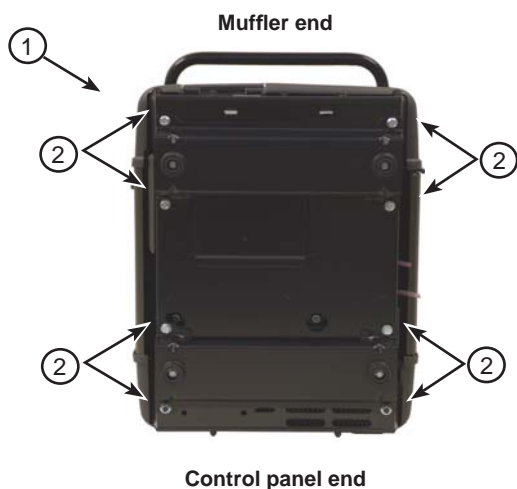

Wheel assembly detail



Front foot bracket



Wheel assembly installed

To attach the new stationary handle:

1. Use 10mm socket to remove the nuts securing the cover panel. Retain hardware.
2. Use 10mm socket to remove the 4 (2 per side) bolts and muffler cover.
3. Use 12mm socket to remove the 4 (2 per side) bolts and existing handle.
4. Slide gap cover over new handle.
5. Use 12mm socket to reinstall handle.
6. Use 10mm socket to replace muffler cover.
7. Use 10mm socket to replace cover panel.



Front panel hardware

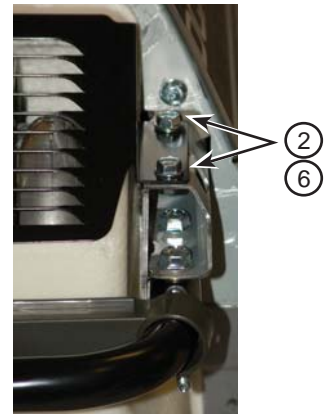

Muffler cover hardware removal

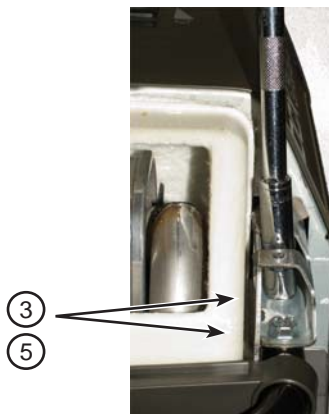

Handle hardware removal

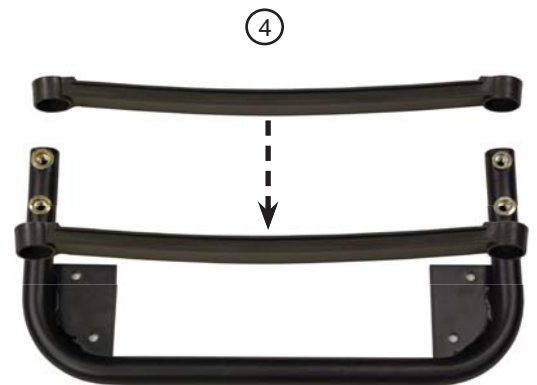

New handle and gap cover

To attach the folding handle:

Parts required:

Description	Quantity	Alpha part number
Left bracket	1	605-149-P3
Right bracket	1	605-148-P3
Handle	1	605-150-P3
1/4-20 x 1/2" bolt	2	630-319-12
1/4-20 x 3/4" bolt	2	630-317-12
1/4-20 x 1-1/2" bolt	2	630-324-12
1/4-20 Nylon lock nut	4	634-030-12-12
Washer, flat	10	635-011-12
Washer, spring	4	633-035-12
Pin, locking, w/lanyard	2	660-122-12

If the handle has not been shipped as a complete assembly, complete the following:

1. Fasten each bracket to the handle as shown in the illustrations below. The handle pivots on a 1/4-20 x 1-1/2" bolt with three washers located as shown below. The bolt is secured by a 1/4-20 nylon lock nut. The end of the lock pin lanyard fits over the stud on the bracket and is held in place by a 1/4-20 nylon lock nut.
2. Fasten the brackets to the welded plates on the handles with the 1/4-20 X 1/2" bolt to the front, and the 1/4-20 x 3/4" bolt to the rear.
3. The portable generator handle is now ready for use. It can be locked either in the up or down position (via the locking pin the left bracket) for transport or storage.

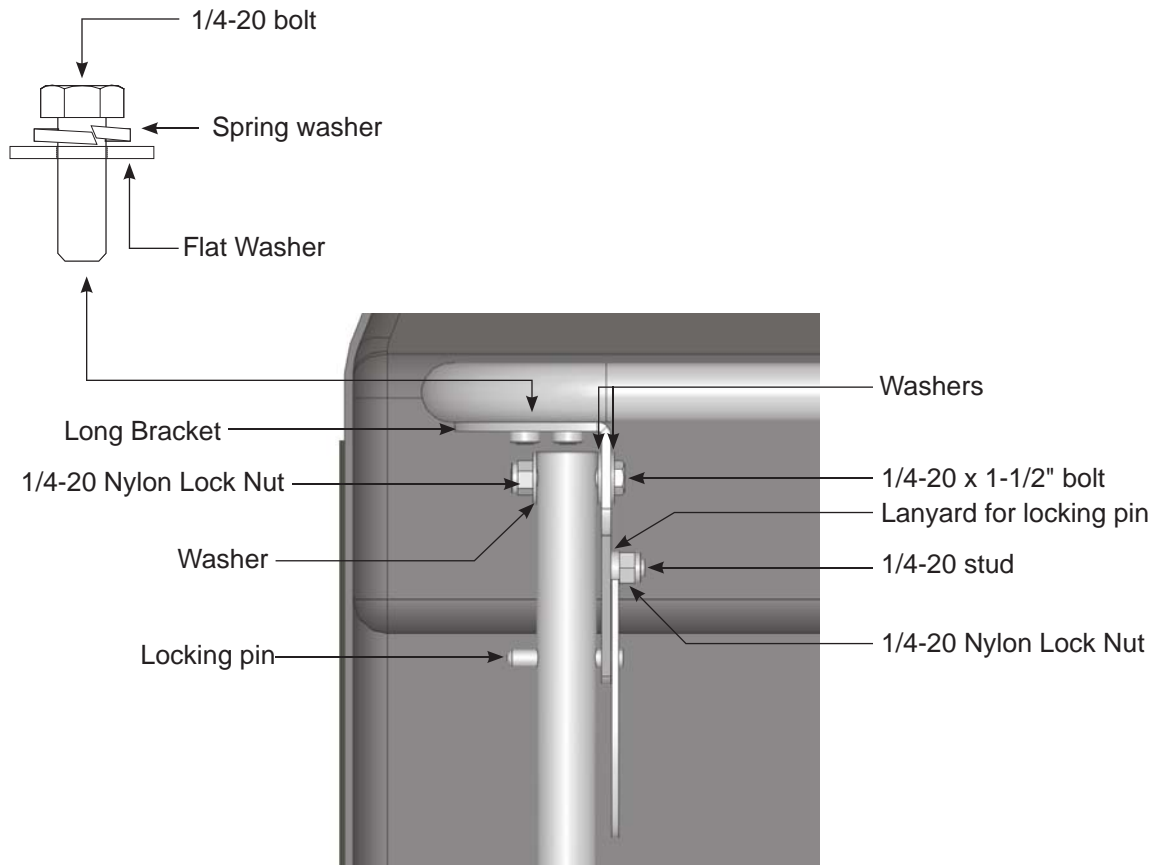

Left bracket assembly detail

Attaching the folding handle, *continued*:

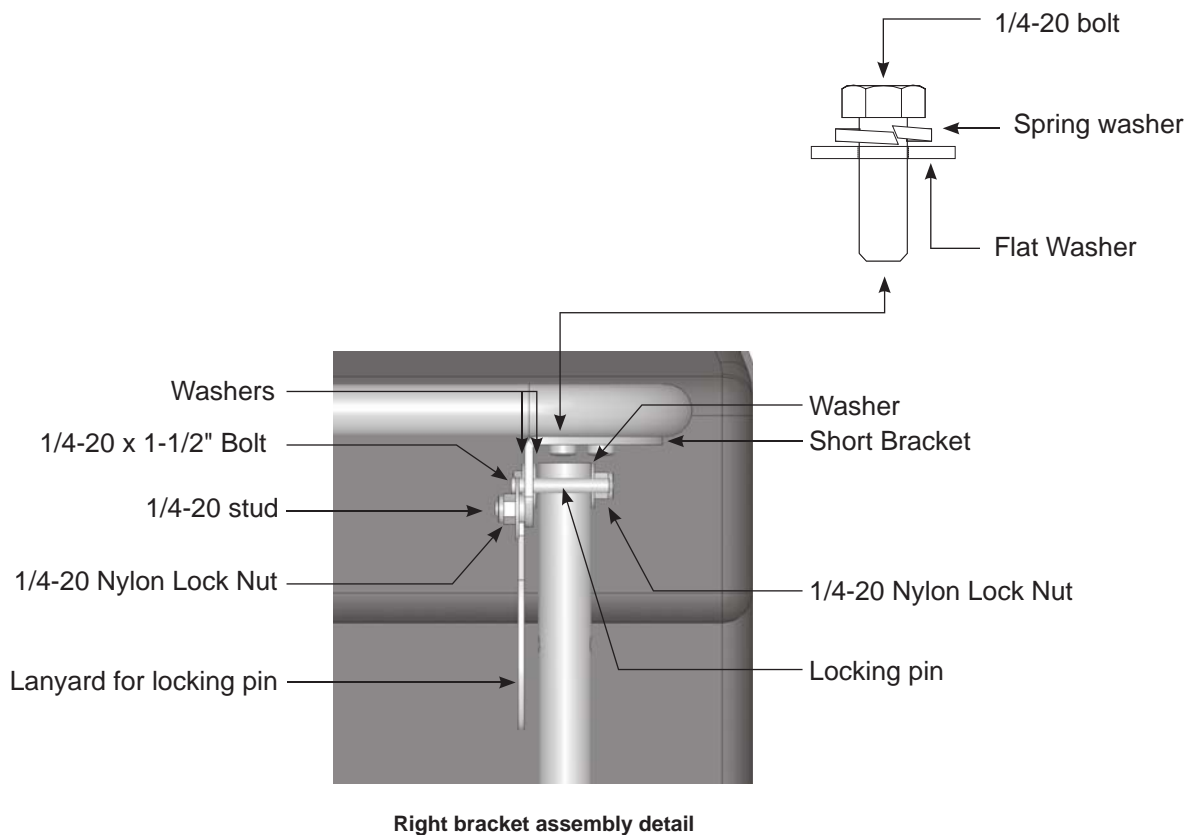

Left bracket assembly detail
(Handle shown up and locked)



Right bracket assembly detail
(Handle shown up and locked)

To attach the optional cable bag (Alpha P/N 745-764-20):

If the optional cable bag is used, it can be attached to the handle by means of cable ties. To attach the cable tie clamp, switch the 1/2" and 3/4" bracket bolts, as the 3/4" bolt is used to hold the cable tie. Orient the bag so the "D" rings are closest to the generator. Loop the upper cable ties through the rear handle of the bag. Secure the "D" rings to the handle with cable ties.



Cable clamp and cable tie locations for optional cable bag

Completed assembly; no cable bag



**Completed assembly with optional cable bag.
Handle in transport mode.**



**Completed assembly with optional cable bag.
Handle in storage mode.**



Power

Alpha Technologies 

Alpha Technologies
3767 Alpha Way
Bellingham, WA 98226
USA
Tel: +1 360 647 2360
Fax: +1 360 671 4936
Web: www.alpha.com

Alpha Technologies Ltd.
4084 McConnell Court
Burnaby, BC, V5A 3N7
CANADA
Tel: +1 604 430 1476
Fax: +1 604 430 8908

Alpha Technologies
Europe Ltd.
Twyford House
Thorley
Bishop's Stortford
Hertfordshire
CM22 7PA
UNITED KINGDOM
Tel: +44 0 1279 501110
Fax: +44 0 1279 659870

Alpha Technologies GmbH
Hansastrasse 8
D 91126 Schwabach
GERMANY
Tel: +49 9122 79889 0
Fax: +49 9122 79889 21

Alphatec, Ltd
P.O. Box 56468
Limassol, Cyprus
CYPRUS
Tel: +357 25 375675
Fax: +357 25 359595

AlphaTEK ooo
Khokhlovskiy Pereulok 16
Stroenie 1
109028 Moscow
RUSSIA
Tel: +7 495 916 1854
Fax: +7 495 916 1349

Alphatec Baltics
S. Konarskio G. 49
Vilnius 2009
LITHUANIA
Tel: +350 5 210 5291
Fax: +350 5 210 5292

Alpha Technologies
5 Avenue Victor Hugo
F 92140 Calmart France
FRANCE
Tel: +33 3 41 90 07 07
Fax: +33 1 41 90 93 12