

SAFETY FIRST

WARNING: It is required that you are aware of the following recommended procedures for Operator's personal safety.

- Never run the gasoline engine (driving your alternator) in your basement or where area is occupied without an approved ventilating and exhaust system. Exhaust fumes are poisonous.
- Gasoline and other fuels will always present a hazard of possible explosion or fire.
- Keep alternator and engine clean. Remove all oil or gasoline deposits, and accumulated dirt from set and immediate area. Poor housekeeping creates a fire hazard.
- Keep a fire extinguisher close by your set and be familiar on how to use it. Consult your local fire department for correct extinguisher type.
- Do not use open flame, braze, cutting torch, arc welding, smoking, etc. near the alternator or engine fuel tank.
- Guard yourself against electric shock. Avoid personal contact with live terminals, wires or receptacles. The electric output voltage in your alternator can produce a fatal electric shock.
- Use the utmost extreme care if it becomes necessary to operate your alternator in the rain, snow, outdoor wet areas or damp cement.
- Use approved three-prong grounded plugs and three wire cords.
- The alternator must be properly grounded. There is a ground lug (labeled) provided on each set for connection by means of copper wire to metal rod driven into earth.
- The operator must remain alert when using or repairing this set. Keep safety guards and shields in place and secured. Avoid hot mufflers, exhaust manifolds and engine parts which may cause severe burns.
- Never work on the set when you are tired. Do not wear loose clothing, dangling necktie, sleeves, long hair, etc. that could become caught in moving parts.
- Lead-acid batteries emit a hydrogen gas when being charged that is very explosive. Do not smoke or be around open flame when charging or servicing battery.
- Do not disconnect battery on electric start models when set is running or cranking. The sparks during disconnection may produce fire or explosion.
- Battery acid can produce skin and eye damage. Use extreme caution when handling any battery.
- Consult a qualified licensed electrician when using your alternator as a home standby set. If you wire alternator output into commercial power wiring (home wire system), certain safety conditions must be met or serious shock and fire hazards could exist.

WARNING: (continued)

- The Home standby installation must comply with all National, State and Local codes.

All gas fuels such as natural gas or LPG must have a separate shut-off for fuel so that unit, during standby condition, does not have fuel pressure to carburetor.

CAUTION:

- Your set is equipped with an air-cooled engine which must have good circulation of air. Any attempts to run the engine in a small, non-ventilated compartment or sound-proof box may seriously damage the engine and the alternator.
- Check the oil every time you fill the gas tank or at least every 5 hours. The weight of oil used depends on ambient temperature of which unit operates.
- The engine should not be used with an external pressure fuel pump.
- Always check wattage requirements on nameplates of motors or appliances before attempting to operate them from the alternator. Remember, motors need additional power to start as opposed to after they are running. See motor and appliance chart in wattage requirements section.
- The external electric load should be applied after alternator is running.
- Engine speed is directly proportional to alternator output. If this speed is incorrectly adjusted by user, serious damage can be done to plugged in load by applying too high or too low voltage to the tools or appliances. Also, high voltage and high speed could destroy the internal parts of alternator.
- If an extension cord is necessary, always use as short a length as possible. The longer the cord, the greater the voltage drop, resulting in less power to the connected load. Consult an electrician for proper gauge on extension cords of 50 feet or longer.
- Exercise your gen-set during periods of infrequent use. You should start and run the set for at least 10-15 minutes, every three weeks to keep engine parts lubricated and to keep copper/bronze parts such as slip ring from forming oxide insulator formations.
- Always follow recommendations of manufacturer on oil changes, filter checks and inspections of all normal wear items.

This manufacturer recommends that all repair and service work be performed by only qualified electrical apparatus servicemen. Use only factory approved repair parts.

TABLE OF CONTENTS

Title	Section	Page
Safety First		1-2
Introduction	1	3
General Information	2	4
Specifications	3	5
Operation	4	6-12
Optional Equipment	5	13-17
Parts Identification	6	18-22
Wattage Requirements	7	23-24
Warranty	7	25

SECTION 1

INTRODUCTION

Your owners manual contains information and instructions necessary for operating your alternator in a safe and proper manner. Read instructions carefully and adhere to all safety rules. These units are rugged and compact, designed and built for dependable, trouble-free operation, and they will provide years of reliable service if given the proper care.

Throughout this manual, watch for the words WARNING or CAUTION and pay special attention to the information accompanying these words. WARNING will give you information of possible personal injury and CAUTION refers to possible unit damage.

Special accessories are available for your alternator and are found in the rear of our price sheet. You should consult your dealer for further information on this type of equipment.

SECTION 2 serves as a general information for the type of alternator you have and how it is constructed.

SECTION 3 gives information in specific detail as to torque, gap settings, etc., that may be required by servicing technician.

SECTION 4 is of particular importance to user. This section describes how to use the alternator set and, more important, describes the dangers of mis-use and wrong installations.

SECTION 5 gives information on how the operator can service the engine and alternator plus provides simple, trouble-shooting principles.

SECTION 6 serves as complete parts identification for parts ordering information. Always give Model number and Serial number when ordering parts for your set.

SECTION 7 serves as a guide for the operator to better judge how to load his alternator set. These charts give approximate wattage consumptions for various appliances and motors.

SECTION 2

GENERAL INFORMATION

This manual applies to all alternator-engine sets or alternators only. Upon receiving your set, carefully unpack the unit and inspect it for damage. If the set is damaged, notify your transportation carrier for immediate inspection and adjustment of your claim.

Your alternator is of the revolving field design and provides 60 (or 50) hertz alternating current at rated RPM. The output voltage can be 120 volts, 240 volts, or a combination of 120/240 volts, depending on the model. All sets are equipped with solid-state exciter system (rectifiers) and small brushes are employed to deliver low current to rotating field coils through rotor slip ring. All normal maintenance items (ball bearing, slip ring, slip ring brushes, rectifiers) are identical throughout all models. For the alternator-engine set, the rotor is coupled directly to engine shaft and alternator end casting is mated to engine flange for exact permanent alignment.

Your alternator set is automatically and inherently self-regulating and its voltage output will adjust to any varying load. Your unit will not be damaged if it is operated at no load condition. It has a large overload capacity, sufficient to handle momentary loads approximately 25% above its rating and 10% overloads for as long as 3/4 to 1 hour.

Starting capacities for induction (motor) loads also are at a high level, being 45% to 50% more than rated nameplate amperage.

Both stator and rotor windings have been given a 1500 volt test from winding to steel frame to insure that wire and insulation stands up under the most severe applications. All sets, prior to packing and shipment, have been operated and adjusted to insure that they will develop their full load capacity at rated frequency.

CAUTION

Before starting the set, refer to separate engine manual for instructions and location of choke stop button, gas shut-off, oil fill, etc.

Wattage is the term used to define electrical power. The number of watts of power that an alternator can produce is its rating and is found by multiplying its rated amperage by its rated voltage. An example would be a 120 volt alternator, producing 25 amps, having a rating of 3000 watts (volts x amps = watts). Induction (motor) loads require more wattage to start than for its normal running wattage. Refer to chart in specification section for starting requirements. Charts are also included on this page to help you select cord extensions, show typical wattage requirements of certain appliances. Obtain actual wattages from tool or appliance nameplates whenever possible.

Each alternator is provided with our nameplate showing: model number, wattage rating, voltage, amperage, rated revolutions per minute, number of phases, internal winding insulation class, rated frequency, rated temperature rise, time rating, power factor, and kilowatt rating.

Your continuous wattage rated alternator is protected from overloads by inherent design. All conductors (alternator lead wires) have an ampacity not less than 115% of nameplate current rating. Neutral conductors shall be the same size as conductors of outside legs. Live parts of alternator of more than 150 volts to ground are not exposed to accidental contact where accessible to unqualified persons. The neutral conductor of all alternators will be internally bonded (grounded) to alternator frame. A ground connecting lug, conspicuously marked, is mounted on outside of all sets.

SECTION 3
SPECIFICATIONS

		Alternator Wattage Size					
		1750	3250	5000	Cast Iron Engines		8500
BRIGGS & STRATTON ENGINES	1250	2250	4000	5000	6500	7500	8500
Displacement Cu. In.	10.4	12.5	19.44	24.36	32.4	32.4	42.33
Bore	2½	2-9/16	3	3-7/16	3-9/16	3-9/16	3-7/16
Stroke	2-1/8	2-7/16	2-3/4	2-5/8	3¼	3¼	2-9/32
Oil Capacity	1¼ pts.	1¼ pts.	2¼ pts.	3 pts.	4pts.	4pts.	3 pts.
Spark Plug Gap	.030	.030	.030	.030	.030	.030	.030
Point Setting	.020	.020	.020	.020	.020	.020	.020
Valve Intake Clear.	.006	.006	.006	.006	.008	.008	.008
Valve Exhaust Clear.	.010	.010	.010	.010	.018	.018	.018

		Alternator Wattage Size					
		1750	3250	5000	Cast Iron Engines		8500
TORQUES (In. Ft. Lbs.)	1250	2250	4000	5000	6500	7500	8500
Cylinder Head Bolts	12	12	14	14	16	16	16
Flywheel Nut	60	60	67	67	144	144	144
Connecting Rod	9	9	14	14	16	16	16
Alt. Adaptor Bolt	15	15	15	15	20	20	20
Rotor Thru Bolt	15	15	15	15	15	15	15
Alt. Thru Bolt	8	8	8	8	8	8	8
Rectifiers	15	15	15	15	15	15	15

Engine Horsepower at 3600 RPM required to drive separate foot mounted, shaft extended, alternators.	Wattage Rating	1250	1750 2250	3250	5000	6500	7500	8500
	Engine Horsepower	3	5	8	10	16	16	18

SECTION 4 OPERATIONS

BEFORE STARTING:

Visually inspect the set before the initial start-up and check for any loose or missing parts or shipment damage. Fill the fuel tank with clean, regular grade gasoline. Un-leaded gasoline will also work in the engine. Premium grades should be avoided.

WARNING: A hot muffler on engine head is a potential fire hazard. Never fill the fuel tank while unit is hot, or running or in the dark.

Fill crankcase with good quality oil. SAE 30 or 10W-40 is recommended when temperatures are above 40 degrees F. Below 40 degrees F, you should use SAE 5-W-20 or 5-W-30.

CAUTION: Do not overfill crankcase and do not mix oil with gasoline as both actions will damage the engine.

Open the fuel shut-off valve below the fuel tank. Remove all electrical loads hooked to the alternator outlets. Never start the engine under load. If the engine has a mechanical type stop lever, make sure it is not touching the spark plug. See Figure 1.

STARTING:

Adjust the carburetor manual choke as necessary for existing temperature conditions. Smaller engines have a push/pull type of choke while larger ones have a rotary type of lever. Cold starting requires a full choke. Pull the recoil starting rope with a fast steady pull.

CAUTION: Do not let it fly loose back into the recoiler as it may damage this mechanism.

As the engine starts, and begins to warm up, adjust the choke back to the open position. the set should be running at the correct pre-set speed and the alternator is now producing electric current. See Figure 1.

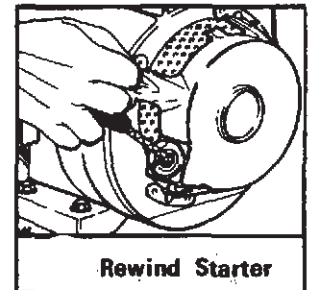
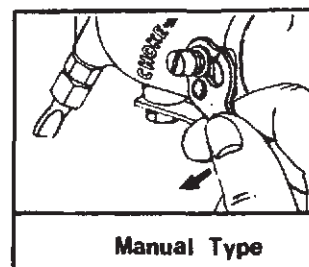
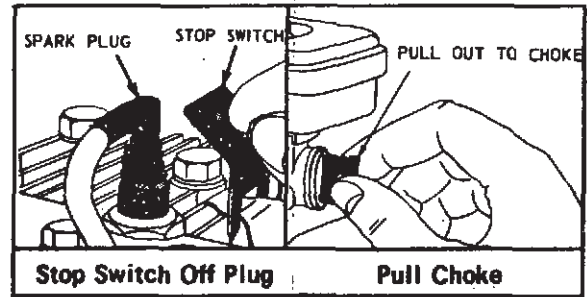
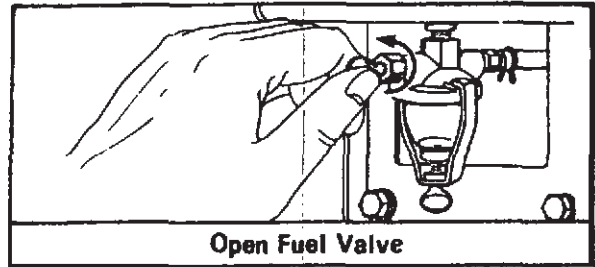

Figure 1

WARNING: Gasoline engines give off deadly carbon monoxide exhausts. Never run the engine in the basement of your house or other occupied areas without approved ventilation.

Units with automatic chokes are preset at the factory and will require no further adjustments or manual engagement. Units with attached engine electric starters will have a momentary contact, push button starter. After the electric starter has been connected to a 12 VDC (35 amp/hr. minimum size) battery, hold the start button in, adjust the manual choke to closed position and the engine will start. Release the button and the engine starter will disengage. Also, open manual choke slowly. See Figure 2.

OPERATION (Continued)

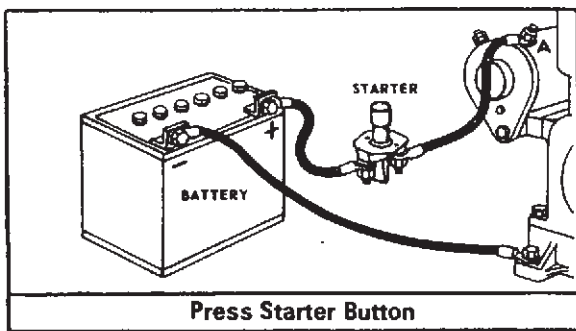

Figure 2

WARNING: Batteries emit explosive hydrogen gas. Smoking, open flame or sparks can cause an explosion. Vented batteries should be used whenever possible.

APPLYING THE LOAD:

Allow the unit to reach normal operating speed & temperature. Avoid connecting an extremely heavy load until after the first one-half hour of operation. Keep the electrical load within the nameplate rating. Continuous overloading may shorten the life of engine and the alternator. Connect load by inserting load plug into the proper receptacle on the set. Use 3-prong plugs to comply with the National Electrical Code (NEC) and Occupational Safety and Health Association (OSHA).

WARNING: One side of current producing load line is internally grounded to alternator frame which forms neutral side. Consult wiring diagram to determine where neutral and hot line could result in dangerous shock hazard.

All sets are equipped with an external grounding lug and so marked.

It is advised by NEC to physically ground the unit by attaching wire to this lug and to a good ground device such as cold water pipe, rod driven two feet into the earth or other approved grounds. Consult tables at end of book for sizing set when running motors and appliances.

OPERATION IN SPECIAL ENVIROMENTS:

When using your alternator set in camping and recreational activities, extreme care should be used if the engine is near dry forest, covered brush or dry grass, which could catch fire from engine heat or exhaust spark.

WARNING: The alternator must have a U.S.D.A. approved spark arrestor muffler to be used in all State and National parks or campgrounds.

Also, many Western states require this type of exhaust spark protection on all gasoline engines used anywhere in their states. A spark arrestor screen is available for all sets.

Do not enclose the alternator set into a confined area such as weatherproof-sound-proof housings, recreational vehicle motor homes or travel trailers.

WARNING: Operation of this set into an enclosed compartment of a recreational motor home or other vehicle compartment is a possible fire hazard and is prohibited by manufacturer.

Ventilation is important for both personal safety and the life of the engine. It is not recommended to run the set indoors. The portable sets are designed for outdoor operation. Indoor operation requires incoming and outgoing cooling air, special muffler with exhaust line outdoors, special fuel considerations.

WARNING: Always provide adequate ventilation for engine operation. The exhaust of engine contains deadly carbon monoxide gases and can cause sickness and possible death if inhaled.

When operation of set during conditions of rain and snow, exert extreme care that you are not in contact with wet earth. Always ground your portable set to earth by means of a metal stake or a ground rod driven into the earth at least two feet. A no. 8 copper stranded ground wire is attached to this rod and the ground lug (so marked) attached on the alternator set. This is in compliance with National Electric Code.

OPERATION
(Continued)

WARNING: The set must be properly grounded to earth for prevention of possible shock hazard.

Low and high temperature operation is dealt with separately. Consult your engine manual or local engine dealer for oil recommendations and type of gasoline to be used. Operation in severe dust or dirt environment can cause early engine failure.

CAUTION: Check engine air cleaner every 5 hours of operation and cooling shroud around engine air passages every 10 hours in severe dust area.

Clogged filters and air passages will destroy engine life. Under normal conditions, it is recommended that the oil be changed in engine crankcase every 25 hours of operation and the engine air cleaner be serviced every 30 to 35 hours of operation. See Figure 3.

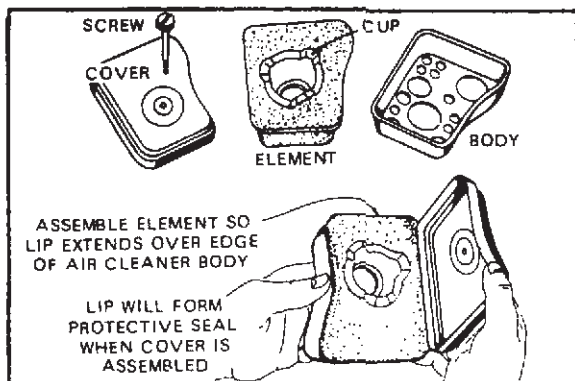
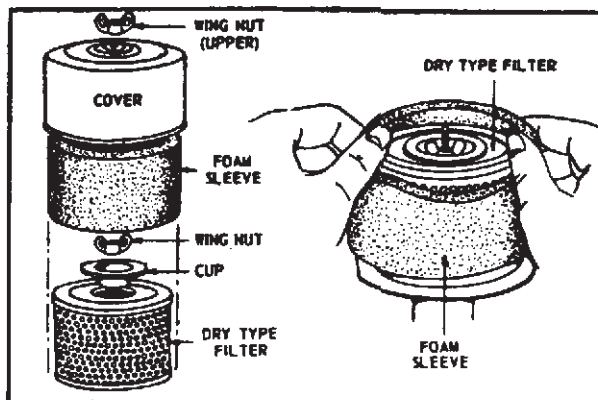

Clean Air Cleaner

Figure 3

USING THE RECEPTACLE PLATE:

All sets are equipped with 3-prong grounded receptacles that will comply with OSHA and NEC specifications. All plugs (caps) should be of the 3-prong ground type, attached to the proper 3-wire cord. All extension cords should be of the 3-wire (ground) type. Figure 4 shows receptacle plate used on the 1.2, 1.7, and 2 KW models with 120 volt output. The duplex 120 V receptacle is rated 15 amps. Figure 5 shows receptacle plate used on 1.2, 1.7, 2, 3, 4, 5 KW models with 120/240 volt output. The duplex 240 V receptacle is rated 15 amps. The duplex 120 V receptacle is split connected for individual receptacle output (see Figure 10). Figure 6 shows receptacle plate used on 3, 4, and 5 KW models with 120/240 volt output and having full wattage output, voltage selector switch. The duplex 240 V receptacle is rated 15 amps.

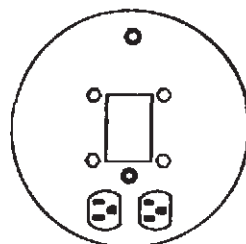

Figure 4

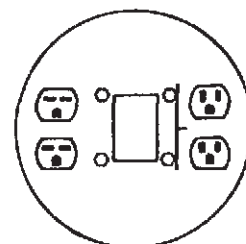

Figure 5

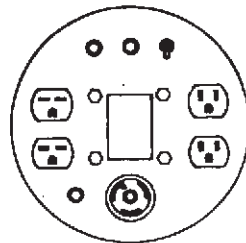

Figure 6

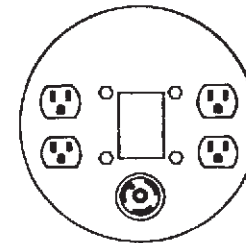

Figure 7

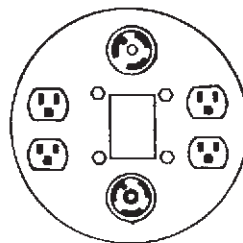

Figure 8

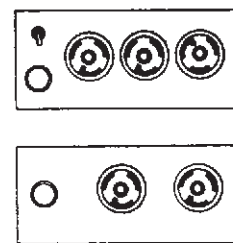

Figure 9

OPERATION
(Continued)

The duplex 120 V receptacle is rated 20 amps (15 amps on 3 KW,) and the three wire, 120 V twist-lock receptacle is rated 30 amps. (See Figure 11-B for selector switch operation.)

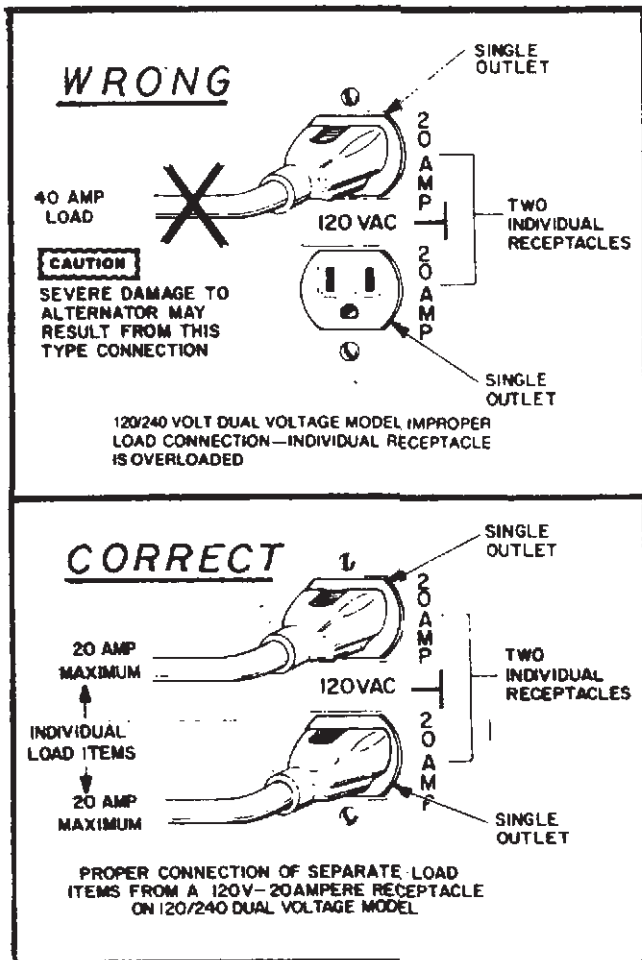

Figure 10

Figure 7 shows receptacle plate used on 6 and 7 KW models with 120 volt output. The two 120 volt duplex receptacles are rated 15 amps, and the single, 120 V three-wire, twist-lock receptacle is rated 30 amps. Figure 8 shows receptacle plate used on 6 and 7 KW models with 120/240 volt output. The 120 V duplex receptacle is rated 20 amp, the single, 120 V three-wire, twist-lock receptacle is rated 30 amps and the single, 240 V, three-wire, twist-lock receptacle is rated 30 amps. Figure 9 shows side mounted receptacle panel having

two 20 amp, three-wire, twist-lock receptacles and large pilot light for 120 volt output, or two amp, three wire, twist-lock, 120 V receptacles; one 20 amp, three wire, twist-lock, 240 V receptacle, large pilot light and voltage selector switch for 120/240 V output.

PROPER USE OF RECEPTACLES:

The three basic output receptacle configurations offered are 120 volt output, 120/240 volt output and 120/240 volt output with voltage selector switch. Proper use of the voltage outlet receptacles installed on your alternator is necessary to avoid alternator and receptacle damage and to insure satisfactory operation.

CAUTION: Do not plug in loads that exceed the amperage rating of the receptacle. This will cause receptacle burn-outs and internal alternator damage. The user must realize that his alternator is not a source of unlimited electric power. The nameplate rating of each set can be obtained by using a combination of receptacles on face plate or through a single receptacle ampere rating is not exceeded. On dual voltage models and models having voltage selector switch, 120 volt and 240 volt receptacles can be used at the same time. **NOTE:** On voltage selector switch models, the switch must be on the 120/240 V position.

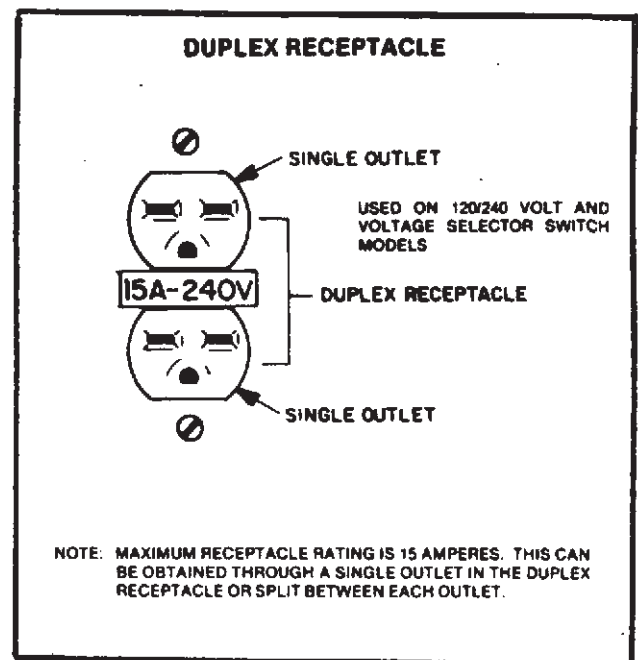

Figure 11

OPERATION
(Continued)

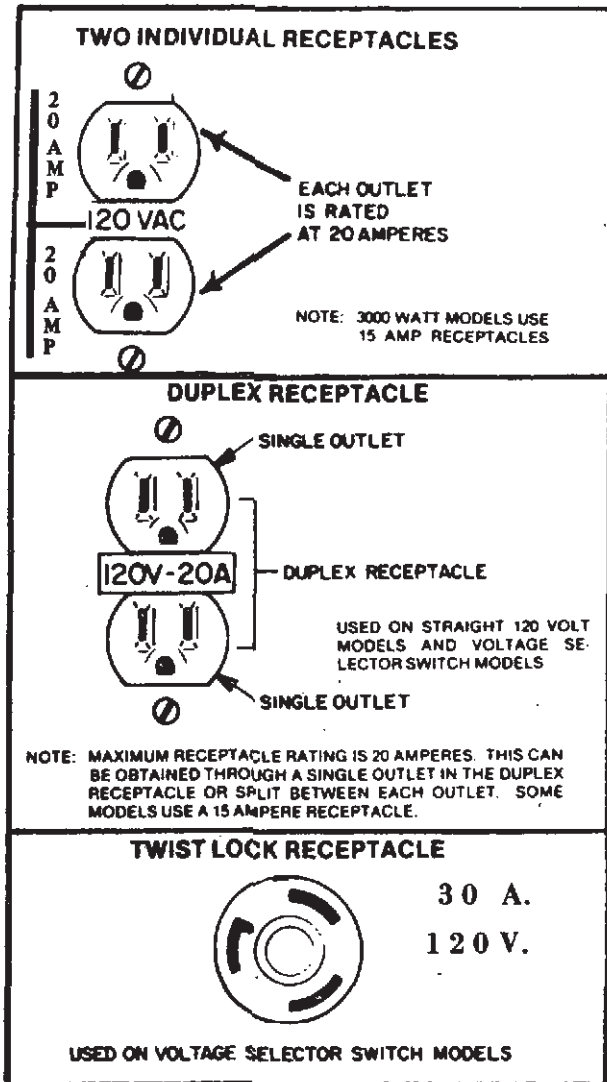

Figure 11-A

VOLTAGE SELECTOR SWITCH:

When 120 V only is selected, the full wattage capacity, up to 30 amps, can be drawn from the 120 volt twist-lock receptacle or the full wattage can be split between the 30 amp single receptacle and the 120 V duplex receptacle. In this position, the 240 volt duplex receptacle has no output. In the OFF position, no power is available. The OFF position is for the primary purpose of causing a delay in switching from one voltage position to the other.

CAUTION: Fast switching from one voltage to another or switching while alternator is under load, may cause damage to the voltage selector switch. In the 120/240 volt position, full wattage capacity can be drawn from

the 240 volt duplex receptacle; but only half of the alternator wattage rating can be obtained from any of the 120 volt receptacles.

See Figure 11

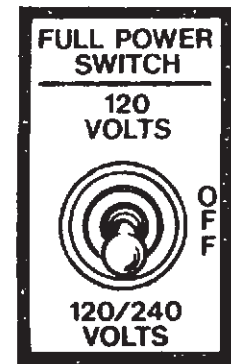

Figure 11-B

PILOT LIGHT:

Some models are equipped with a neon light. This light is for the main purpose of showing that the alternator is producing a voltage. Foot-mounted, shaft extended alternators only for belt drive application may have voltmeters installed as optional equipment so that correct speed can be determined by watching voltage registered on voltmeter. Figure 12 shows the operation of the voltmeter for various models.

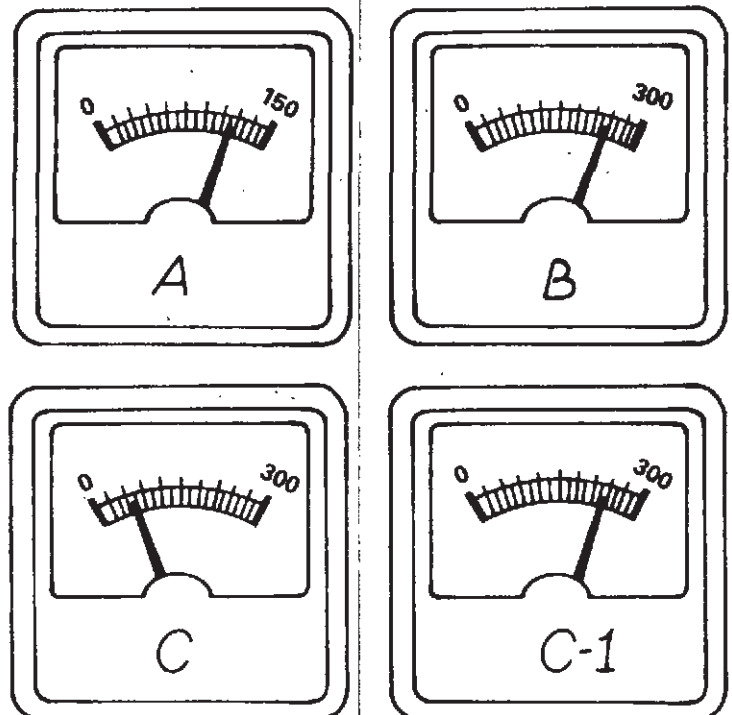

Figure 12

VOLTMETER "A" shows proper needle deflection for operation on 120 Volt Alternators. VOLTMETER "B" shows proper needle deflection for operation on 120/240 Volt or 240 Volt only. VOLTMETER "C" shows proper needle deflection for operation on 120/240 Volt alternators equipped with full output dual voltage switch, while switch is in the 120 Volt position. VOLTMETER "C-1" is the same meter and shows proper needle deflection when switch is in the 120/240 Volt position.

OPERATION (Continued)

LOAD DISCONNECTION:

The alternator is inherently self-regulating and will adjust itself as to voltage output as load is applied. The engine governor is a mechanical fly-ball type and compensates in speed for load variations. If possible, it is most desirable to remove load gradually.

CAUTION: Removing a full rated load or severe overload immediately may damage field rectifiers.

A shorted load or repeated connection and disconnection of full load (more than six times per minute) may destroy permanent magnets in rotor.

SHUTDOWN:

Remove the electric load and let engine run a few minutes. Push the STOP lever against spark plug (push STOP button if engine is equipped with it) until unit comes to a complete stop. Releasing the stop mechanism too soon may allow the engine to start up again and continue to run. Never leave the set until the engine has completely stopped.

WARNING: On spark plug, stop lever models, a severe shock will result if the terminal of spark plug is touched while pushing stop lever toward the spark plug. See Figure 13.

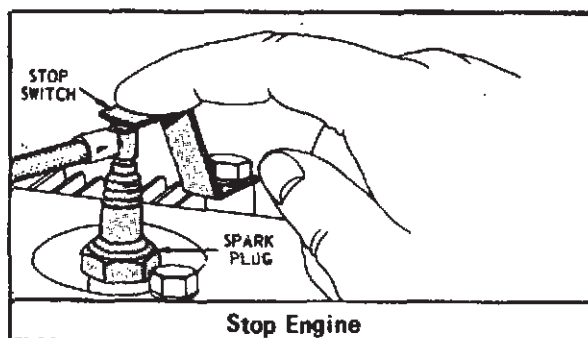

Figure 13

APPLYING THE LOAD:

Allow the alternator to reach normal operating speed and temperature. Avoid connecting an extremely heavy load until after the first one-half hour of operation. Keep the electrical load within the nameplate rating. Continuous overload may shorten the life of the alternator and the engine. Connect load by inserting load plug (cap) into the proper receptacle on receptacle plate. Use 3-prong plugs (caps) to comply with the National Electrical Code (NEC) and Occupational Safety & Health Association (OSHA).

WARNING: This unit must be properly grounded to prevent a lethal electric shock hazard. All sets are equipped with a ground lug and marked as such.

A No. 8 copper stranded ground wire must be attached to this lug and the other end of wire attached to a suitable ground such as a metal stake driven at least two feet into the earth.

WARNING: Conductors on 5 KW and smaller units are not grounded to alternator frame. On 6 KW and higher sizes, one side of current producing load line is internally grounded to alternator frame which forms neutral side.

Consult your local electrician to determine where neutral line is before you wire alternator output into other switch boxes, controls or anything else other than portable plugged-in equipment. Reversing the neutral and hot line could result in dangerous shock hazard.

CAUTION: Be sure to keep the plugged in load on alternator, within the nameplate of the plugged in equipment (motor, drill, heater, etc.) multiplied by the voltage that alternator produces equals the watts consumed --
(volts x amps = watts).

OPERATION (Continued)

The nameplate ampere rating of an electric motor must be multiplied by a factor of 3 in compensating for the starting winding load. See motor starting and appliance load at end of book. Do not increase engine speed to start large motors or to compensate for long extension cords. The engine is designed to operate at 3600 RPM.

CAUTION: Excessively high engine speed results in severely high voltage output which could damage loads such as lights, television, record players, etc.

INFREQUENT SERVICE:

If the alternator set is used infrequently, it may become difficult to start the engine. Gasoline will form a varnish-like residue when left in the fuel system for long periods of time. This tends to clog up the fuel lines and carburetor. There are gasoline additives that prevent varnish build-ups which can be purchased from your local engine dealer. Also, the slip ring of alternator may become corrosive. This will set up an oxide film which actually insulates the brushes from slip ring and stop all electrical output. Run a commutator stone or sandpaper over the slip ring to solve the problem.

LONG PERIODS OF STORAGE:

If your set is to be used very infrequently, or is to be stored away for a long time, the following procedure should be used:

1. Run your set until it is of normal operating temperature (approximately 15 minutes).
2. Drain all fuel from tank and carburetor fuel bowl.
3. Drain all oil from engine crankcase and fill with correct, fresh oil.
4. Service air cleaner.
5. Plug exhaust outlet to prevent entrance of foreign items or dirt.
6. Remove spark plug and pour one ounce (2 tablespoons) of heavy SAE-50 oil or a rust inhibitor into top of cylinder. Crank the engine slowly by hand and replace the spark plug.

7. Plug all alternator holes to prevent dirt, bugs and rodents from entering.
8. Coat items that are susceptible to rust with a thin coat of oil or grease.
9. Provide unit with protective cover.
10. Before putting set back in service, remove all plugs and protective covering, material, etc. Remove spark plug and pull manual rope starter several times. This will exhaust excessive oil from cylinder. Pour fresh gasoline into tank and proceed with starting the engine.

FOOT-MOUNTED, SHAFT EXTENDED, BELT DRIVE ALTERNATORS:

These alternators are identical to the ones that are directly attached to the gasoline engine. Their main purpose is to be used where the owner has his own engine, electric motor or small garden tractor and wishes to make up his own custom alternator set. The alternator can be direct coupled or belt driven to the prime mover. The alternator can be driven in either direction of rotation. Cooling is equally efficient in either direction. The speed of your alternator must be 3600 RPM. (3000 RPM for 50 Hertz Alternators) This can be checked by using a manual tachometer on alternator shaft, or by plugging a vibrating reed type frequency meter into receptacle outlet. The alternator can also be tested with a voltmeter, plugged into the 120 V receptacle. In this manner the speed should be adjusted so that frequency is 61 hertz; or voltage is 130 on 120 V set; or voltage is 265 on 240 V set; all at no load conditions. The voltage from no load to full load is expected to vary in this manner and is perfectly safe for any appliance, motor, or lighting application. When installing your belt drive alternator, it is recommended that the belt be perfectly aligned.

WARNING: Make sure that the complete belt drive or coupling is guarded by full metal enclosure. Loose clothing, long hair, hands, etc., can become caught between belt and pulley while set is operating.

SECTION 5

OPTIONAL EQUIPMENT

VOLTMETER:

If your set is equipped with a voltmeter, you can judge from its operation whether the unit is adjusted correctly. Under no load, voltmeter should read approximately 120-135 volts (240-270 volts on dual voltage models). If any lower or higher reading is registered, you should adjust engine speed up or down to correct output. Voltage output is directly dependent on the speed that alternator is driven.

(See Figure 12)

SPARK ARRESTER SCREEN:

This screen is installed in the muffler and provides the exhaust system with an approved United States Department of Agriculture (USDA) Forestry muffler. All sets can have this modification. All State and Federal parks, and many State regulations will not permit the operation of gasoline engines without this modification.

CAUTION: This screen must be removed and cleaned after every 75-100 hours of operation. If not, serious damage may be done to engine.

SPEED-MATIC IDLE CONTROL:

This all solid-state, electronic idle device is located inside the inspection band, mounted on the through bolt of your alternator. The receptacle panel includes an OFF--ON toggle switch, which when in the ON position and no load being used from the set, will control the engine speed at approximately 2000-2100 RPM. As soon as power is consumed (electric load of 75 watts and up), the sensor module deenergizes engine throttle solenoid and engine speed automatically picks up to 3600 RPM. When load is removed, the engine speed again returns to the slow speed automatically. There is a fuse installed in control

panel to protect sensor module in the event that engine solenoid fails. When switch is in the OFF position, engine speed will run at constant 3600 RPM regardless if load is applied or not. This device is intended to save fuel and prolong engine life during long periods of use and infrequent loads applied.

BATTERY SET:

All electric start alternator sets can be equipped with a battery to power the engine starter. This set consists of a battery tray welded to the base, a 35 amp-hour dry charge battery, hold-down clamp to secure battery tray and the starting cables hooked from battery to appropriate locations on set. This battery is dry to conform with Interstate Commerce Commission regulations, and it must be filled with electrolyte, which is obtained at any local automotive supply store.

WARNING: Use extreme caution when handling batteries. Battery acid is extremely corrosive and can cause severe burns to eyes, skin and clothing. Flush areas contaminated immediately with water and call a doctor.

All electric start units include a battery trickle charger which operates only when the engine is running. Provisions must be made to keep the battery fully charged if the alternator will not be frequently run as in the case of a permanent stand-by installation. This can be accomplished by a battery trickle charger of 2 amps maximum plugged in normal commercial power source, and not the alternator.

CAUTION: Overcharging of battery may cause physical damage. Always use an automatic trickle charger or if it is manual, do not exceed 2 amps capacity.

OPTIONAL EQUIPMENT

(Continued)

Check battery cells with a hydrometer. The specific gravity reading of each cell should be about 1.280 at 75 degrees F. If cells are low, add water and re-charge battery. Keep the battery clean and dry. Constant moisture conditions or storage on cement or earth may discharge the battery. Keep battery terminals clean. After making connections to battery terminals, coat the fittings with light grease, or petroleum jelly to retard corrosion.

WARNING: Disconnection or connection of battery terminals while engine is running could cause violent spark and result in explosion. Never smoke or use open flame near battery. The room should be well ventilated because batteries give off an explosive gas when being charged.

TWO WHEEL DOLLY:

All models can be equipped with a two-wheel dolly kit. This comes un-assembled and is readily adapted to all sets from 3000 watts and larger. The kit has ten inch hard rubber tires and is made for manually pushing it. It is not intended for towing by vehicle.

EXTRA-QUIET MUFFLER:

This muffler is suited for sets that are intended for standby, emergency power applications. The muffler outlet is threaded so that a flexible exhaust hose can be installed between this muffler and a rigid exhaust hose (or pipe) that leads to outside.

GAS FUELS:

The carburetor of your engine can be modified to utilize L-P (vapor withdrawal) or natural gas fuel. This fuel, because of its lower BTU burning rate, will derate the engine horsepower, therefore derating the alternator output by 10% for L-P fuel and 20% for natural gas fuel. The Briggs and Stratton engines can be adapted for dual fuel (gasoline and gas vapor), or single gas fuel.

Each set will have its separate sheet of regulations and instructions covering the alternator set with this fuel modification. These engines can also be modified at a later date by purchasing a carburetor kit from manufacturer.

OIL SAVER:

This device consists of a sensor probe installed in your engine crankcase where the oil fill cap is located. Its function is to monitor oil level in your engine. As it reaches a predetermined low level, the probe senses this, and by means of engine vacuum, pumps fresh oil from an external 2-quart tank, into the crankcase. The main purpose is to protect the engine from damage to low oil level. The kit can be installed by manufacturer or by your local engine service station.

RUNNING TIME METER:

This hour meter records the actual time that your set is in operation. It serves as an aid for rental applications or for a reminder to service various parts at certain times.

FUEL PUMP:

A mechanical vacuum operated fuel pump is available if it is desirable to have a larger remote fuel tank located below the carburetor line (no more than three feet) and no more than ten feet away.

FUEL TANK:

A five gallon fuel tank is offered for the Briggs and Stratton engines, 7 HP through 16 HP, to extend the normal fuel tank running time. The original engine mounted tank line must be disconnected and the line from optional tank is to be hooked directly to carburetor.

CAUTION: Do not use a tank larger than 20 gallons on gravity feed system as pressure may damage float system of engine carburetor.

OPTIONAL EQUIPMENT

(Continued)

MANUAL TRANSFER SWITCH:

This device is used for connecting the alternator electric power output to the permanent home wiring system. It provides a means of isolating the alternator power from the normal power so that when the alternator is being used during a blackout, and normal power is restored, it will not conflict with emergency power.

HOME STANDBY INSTALLATION:

Most home commercial power service is of 60 amp capacity or more. Some home services are rated at 200 and 300 amps. Your portable alternator set does not have this output capacity to power your complete home electric needs. Only the major electric loads can be connected to your power plant (up to ampere rating of alternator) during an emergency power blackout.

The alternator can be used without extensive home rewiring by merely plugging loads. During power outage, the alternator set can be run outside your home, and with use of heavy duty, 3 conductor grounded extension cord plugged into alternator receptacle plate, the other end can be brought into house and individually plugged into key items such as sump pump, furnace, blower motor, refrigerator, freezer, etc. Review wattage chart for motors and appliances in Section 7.

WARNING: Never hook alternator output directly into home electric circuits. If normal power is restored and alternator power is also energized, a shock and fire hazard exists to all members of household.

WIRING ALTERNATOR INTO EXISTING ELECTRIC CIRCUITS:

If the alternator is to be wired permanently into home wiring system, a positive means of isolating the alternator electric power and normal commercial power must be installed. This is accomplished by installing a suitably rated, double-pole, double throw manual transfer switch.

(See Figure 14)

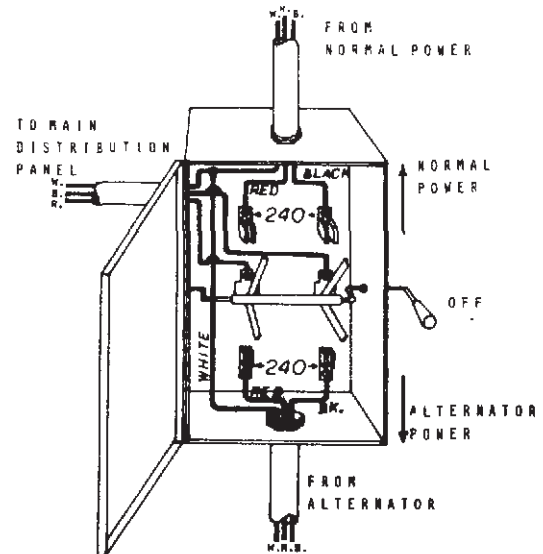

Figure 14

TRANSFER SWITCH INSTALLATION:

Your electrician would probably install the transfer switch in the basement or garage between the electric meter and the home fuse or circuit breaker panel. A power run would be made from the manual transfer switch to a junction box located at the immediate area of the portable alternator location. A cord set running from this junction box to the alternator would be plugged into the 240 volt receptacle on face plate of alternator by means of suitable cap mounted on end of cord.

(See Figure 15.)*

ALTERNATOR CONNECTION METHODS:

There are two methods of connecting alternator to transfer switch. The first method is the "Chosen Circuit" load method that you wish to power feed with alternator. These chosen loads should never exceed the wattage rating of the alternator that you have selected to do the job. These loads are rewired into a separate load panel. The manual transfer switch with an ampere rating equal to the ampere rating of your selected emergency loads would then be connected between the home fuse or circuit breaker panel and the alternator power. The chance of accidentally overloading the alternator by this method is small. When power outage occurs, start the alternator, switch

OPTIONAL EQUIPMENT

(Continued)

the manual transfer switch in the generator position and the emergency circuits will now be powered by the alternator, while the normal commercial power is shut off and isolated from the home wiring system. When the normal power is restored, the transfer switch is returned to the normal power position. This isolates the alternator power from the home wiring circuits. The alternator can be shut down and all circuits will now be powered by normal power source.

See Figure 16

The second method is the "Total Circuit" connection method. The manual transfer switch must be of the same ampere rating as the total commercial power service. During a blackout, the individual home circuits are turned off by removing fuses or turning off circuit breakers. The alternator is started and the transfer switch is turned to generator power. Now, the circuits

to be powered by emergency alternator power is selected and turned back on by screwing in plug fuses or turning on circuit breakers. Caution must be used because if too many circuits are turned on, you may overload your alternator.

When normal power is restored, turn transfer switch to normal power, switch on all circuits in home power panel and shut down alternator.

See Figure 16.

WARNING: All permanent wiring must comply with the National Electric code & all local and state codes. You must consult a qualified electrician to avoid mis-wiring and possible shock hazard. Installing a home emergency power system to your existing home circuits is not a do-it-yourself project.

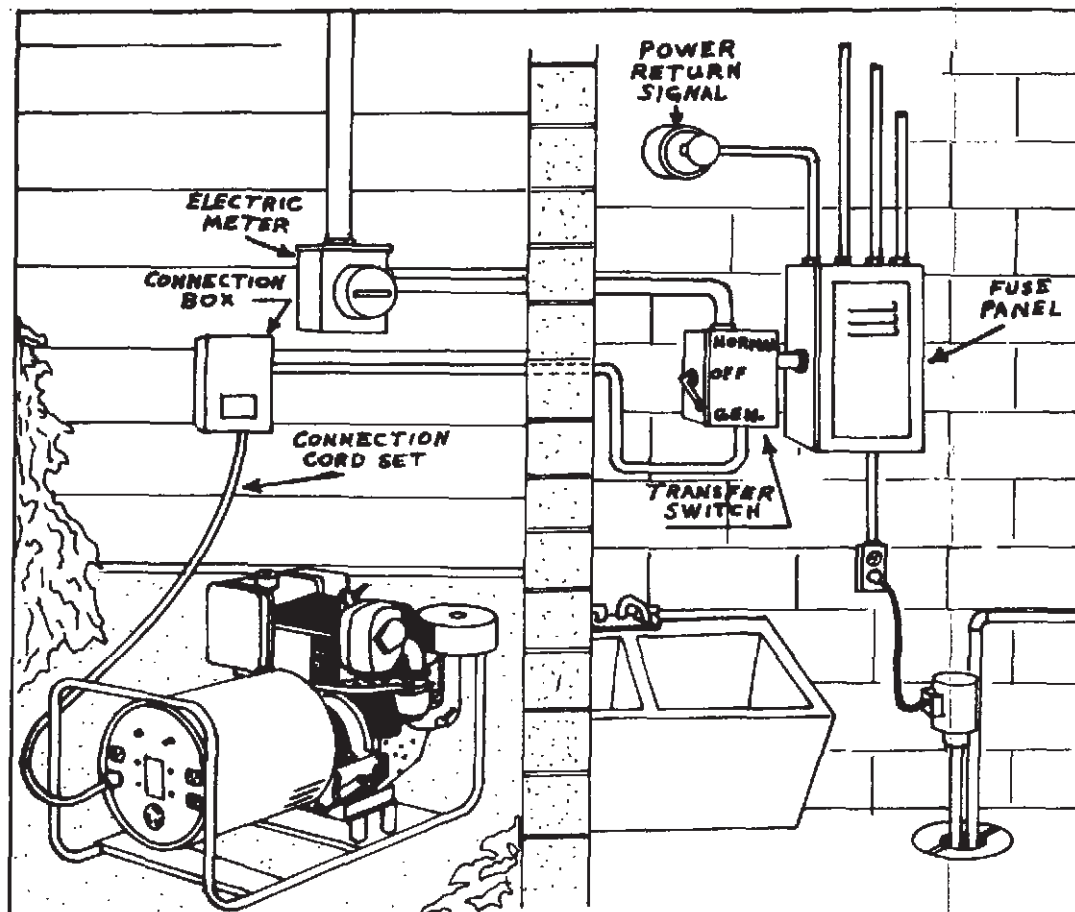

Figure 15

SECTION 6

PARTS IDENTIFICATION

4 and 5 HP MODEL BASE

AND

CARRYING HANDLE PARTS

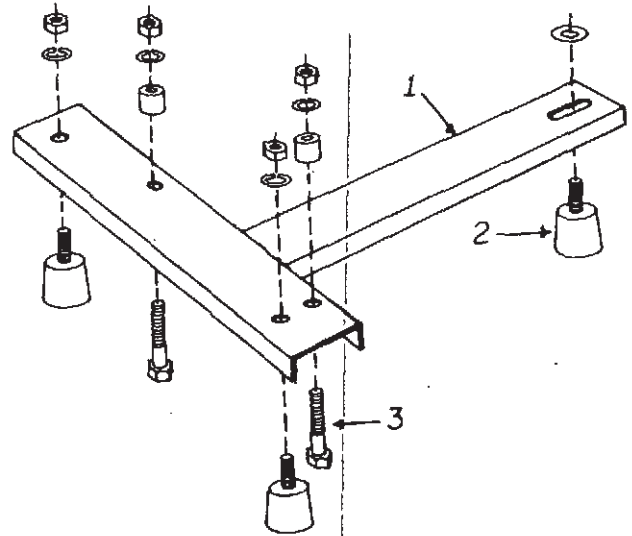
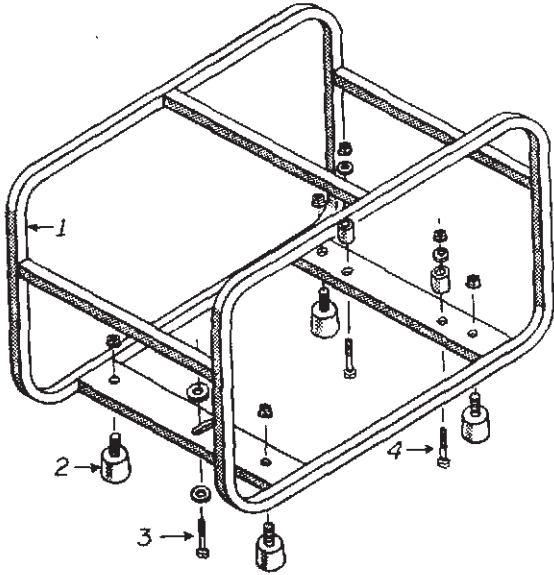

ITEM	PART NO.	REQ'D.	DESCRIPTION
1	M-201	1	3 & 5 HP Wrap-Around Frame
2	M-203	4	Vibration Isolators
3	M-204	2	Engine Mounting Hardware Pkg.
4	M-204-1	1	Alternator Mounting Hardware Pkg.

ITEM	PART NO.	REQ'D.	DESCRIPTION
1	M-200	1	3 & 5 HP Base
2	M-203	3	Vibration Isolators
3	M-204	2	Engine Mounting Hardware Pkg.

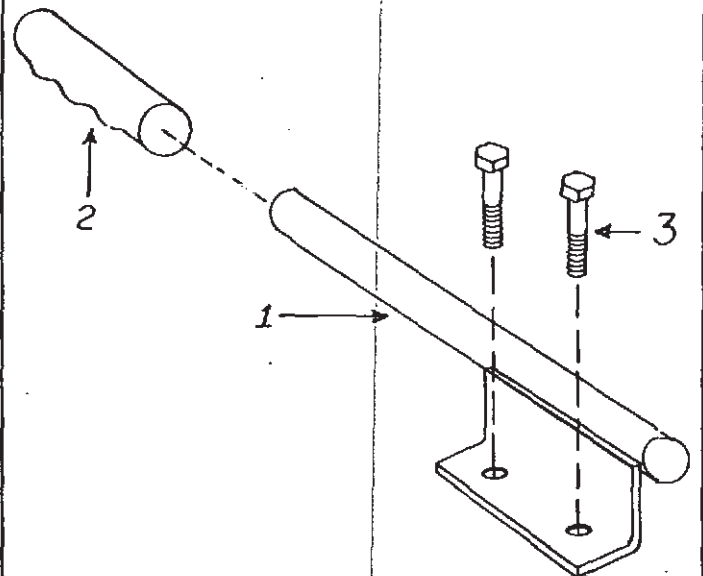
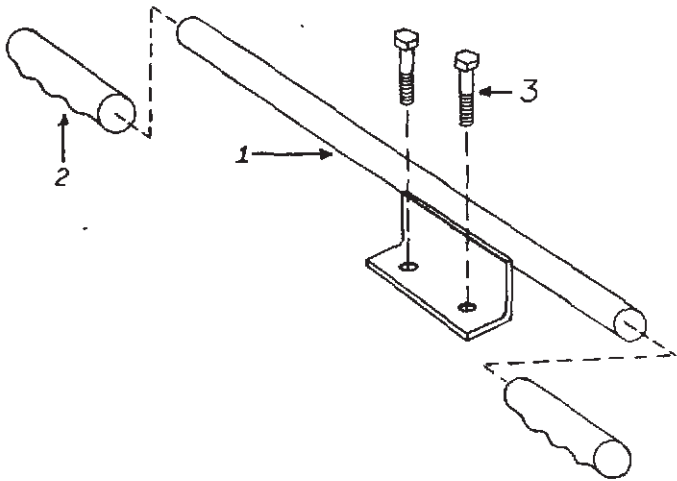

ITEM	PART NO.	REQ'D.	DESCRIPTION
1	M-215	1	5 HP Carrying Handle
2	M-216	2	Rubber Handle Grips
3	M-217	1	Handle Mounting Hardware Pkg.

ITEM	PART NO.	REQ'D.	DESCRIPTION
1	M-218	1	3 & 5 HP One-man Carry Handle
2	M-216	1	Rubber Handle Grip
3	M-217-1	1	Handle Mounting Hardware Pkg.

NOTE: ALWAYS GIVE MODEL AND SERIAL NUMBER WHEN ORDERING PARTS.

PARTS IDENTIFICATION
(Continued)

7, 8, 10 AND 16 HP MODEL BASE ASSEMBLY PARTS

**7, 8 and 10 HP
Aluminum Engine
Base**

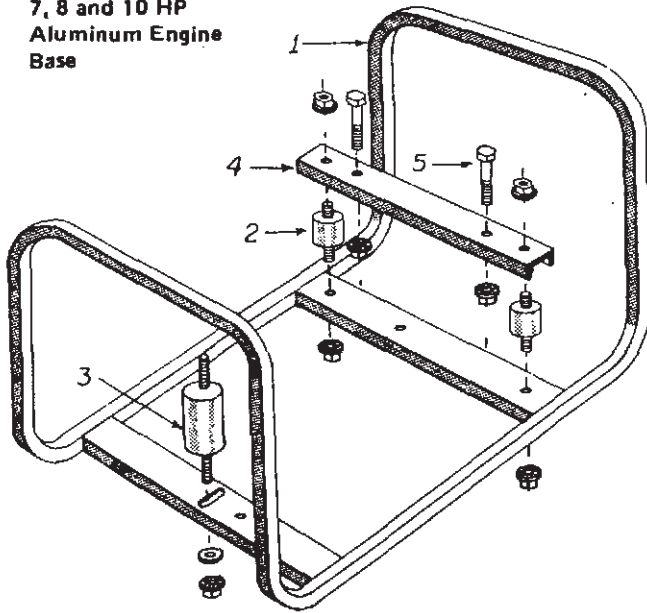

ITEM	PART NO.	REC'D.	DESCRIPTION
1	M-202	1	Carrying Frame
2	M-205	2	Vibration Isolators
3	M-206	1	Vibration Isolators
4	M-219	1	Engine Channel Base
5	M-220	1	Engine Mounting Hardware

**16 HP B & S
Cast Iron Engines,
Wisconsin Robin
Engines Base Frame**

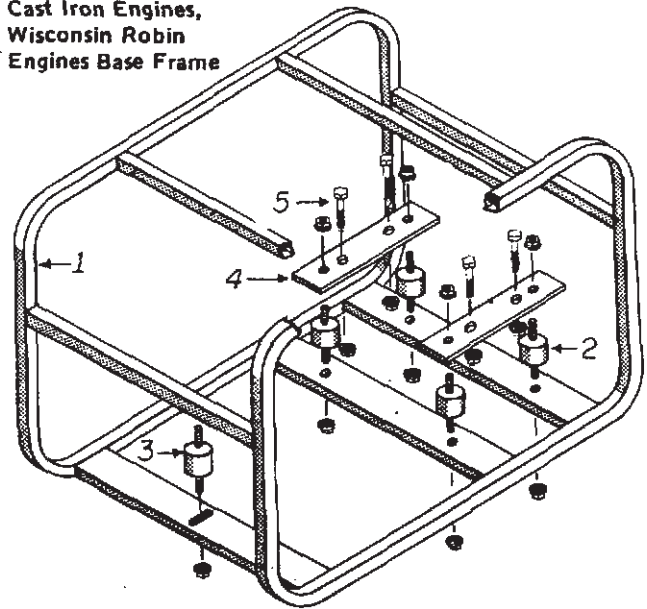

ITEM	PART NO.	REC'D.	DESCRIPTION
1	M-202-1	1	Wrap-Around Frame
2	M-205	4	Vibration Isolators
3	M-206	1	Vibration Isolator
4	M-219	2	Engine Channel Base
5	M-220	2	Engine Mounting Hardware Package

2 Wheel Dolly Kit

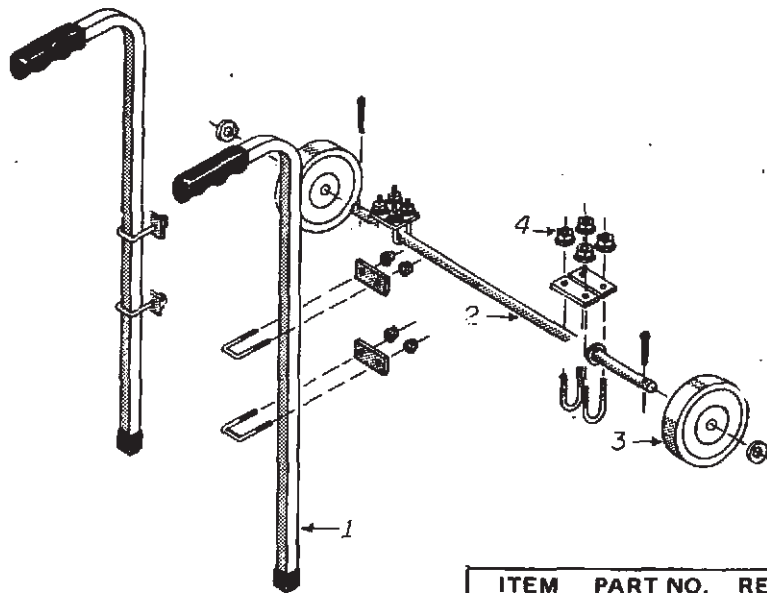

(Frame not included.)

ITEM	PART NO.	REC'D.	DESCRIPTION
1	M-230	2	Handle Assembly
2	M-231	1	Base Assembly
3	M-232	2	Wheels
4	M-233	1	Hardware Package

NOTE: ALWAYS GIVE MODEL AND SERIAL NO. WHEN ORDERING PARTS.

PARTS IDENTIFICATION
(Continued)

ALTERNATOR REPAIR PARTS LIST			WATTAGE								
			1250	1750	2250	3250	4000	5000	6500	7500	8500
REF. PART NO.	NO.	DESCRIPTION									
A	106	Engine Adaptor							1	1	1
B	112	1/4" Lg. Hex Bolt & Washer, 7/16" Dia.							4	4	4
C	110-A	Engine Casting	1	1	1				1	1	1
C-2	110-B	Engine Casting				1	1	1			
D	114	Hex Bolt & Washer, 5/16-24, 1" Lg.	4	4	4				4	4	4
D	115	Hex Bolt & Washer, 3/8-16, 1/4" Lg.				4	4	4			
E	*116	Cooling Fan	1	1	1	1	1	1	1	1	1
F	118	Stator Assembly, 1250W (1000 w/50 HZ)	1								
F	118-1	Stator Assembly, 1750W (1500 w/50 HZ)		1							
F	118-2	Stator Assembly, 2250W (2000 w/50 HZ)			1						
F	118-3	Stator Assembly, 3250W (2750 w/50 HZ)				1					
F	118-4	Stator Assembly, 4000W (3500 w/50 HZ)					1				
F	*118-5	Stator Assembly, 5000W (4250 w/50 HZ)						1			
F	*118-6	Stator Assembly, 6500W (5500 w/50 HZ)							1		
F	*118-7	Stator Assembly, 7500W (6500 w/50 HZ)								1	
F	*118-8	Stator Assembly, 8500W (7000 w/50 HZ)									1
G	119	Rotor Assembly (1250W)	1								
G	119-1	Rotor Assembly (1750W)		1							
G	119-2	Rotor Assembly (2250W)			1						
G	119-3	Rotor Assembly (3250W)				1					
G	119-4	Rotor Assembly (4000W)					1				
G	*119-5	Rotor Assembly (5000W)						1			
G	*119-6	Rotor Assembly (6500W)							1		
G	*119-7	Rotor Assembly (7500W)								1	
G	*119-8	Rotor Assembly (8500W)									1
H	*120	Ball Bearing	1	1	1	1	1	1	1	1	1
I	109	Bearing Casting	1	1	1	1	1	1	1	1	1
J	*121	Rotor Bolt, Spacer, Washer	1	1	1	1	1	1	1	1	1
K	*122	Stator Thru Bolt, Nut, Washer	4	4	4	4	4	4	4	4	4
L	123	Complete Brush Holder Assembly w (2) Brushes	1	1	1	1	1	1	1	1	1
M	124	1/2" LG. Round Head Bolt, Washer	2	2	2	2	2	2	2	2	2
P	127	Brush	2	2	2	2	2	2	2	2	2
Q	128	Rectifier (Diode)	2	2	2	2	2	2	2	2	2
R	129	Inspection Cover	1	1	1	1	1	1	1	1	1
S	130	Cover Screw, 10-24, 1/2" Lg.	2	2	2	2	2	2	2	2	2
T	131	120 V Duplex Receptacle	1	1	1	1	1	1	1	1	1
T-1	131-A	240 V Duplex Receptacle	1	1	1	1	1	1	1	1	1
U	132	Indicator Light	1	1	1	1	1	1	1	1	1
V	133	Receptacle Screw, Nut and Washer	2	2	2	6	6	6	8	8	8
W	134	Face Plate Screw, Washer	4	4	4	4	4	4	4	4	4
X	*135	Face Plate	1	1	1	1	1	1	1	1	1
Y	136	120 V Receptacle, 30 Amp.				1	1	1	1	1	1
Y-1	136-A	240 V Receptacle, 30 Amp.							1	1	1
Z	137	Dual Voltage, Full Output Switch				1	1	1			
	138	Briggs & Stratton Engine, 3 HP	1								
	139	Briggs & Stratton Engine, 5 HP		1	1						
	*140	Briggs & Stratton Engine 8 HP				1	1				
	*141	Briggs & Stratton Engine 10 HP						1			
	*142	Briggs & Stratton Engine 16 HP							1	1	
	*143	Briggs & Stratton Engine 18 HP									1

*These parts will vary in size and length according to the different style of engines that are used to drive the alternator. For this reason, full information of model number and serial number will be required when ordering parts. For all foot mounted alternator only parts, add suffix "B" to above listed items.

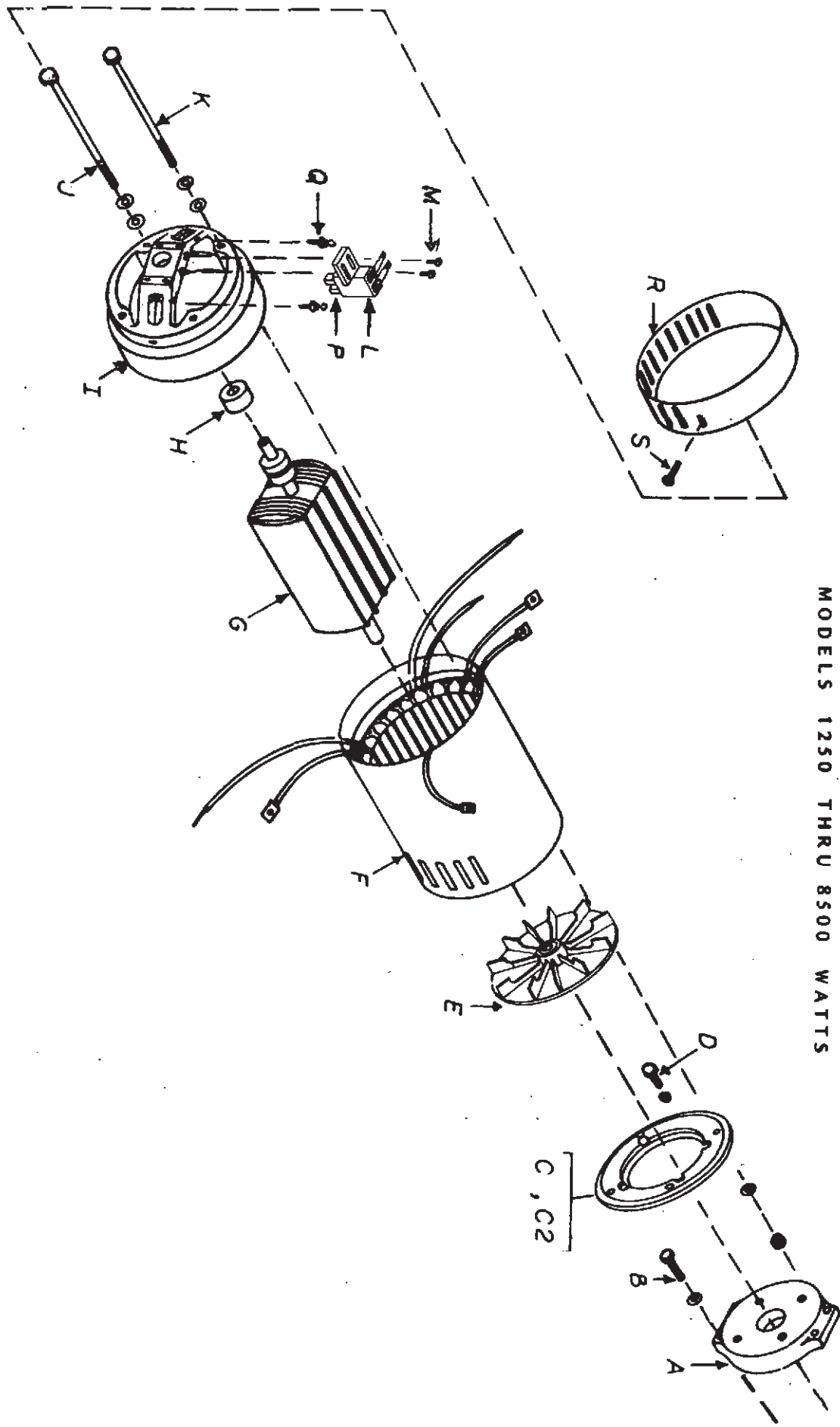

MODELS 1250 THRU 8500 WATTS

PARTS IDENTIFICATION
(Continued)

RECEPTACLE PLATE VARIATIONS

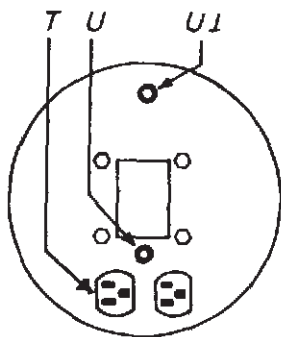

A
SINGLE VOLTAGE
MODELS

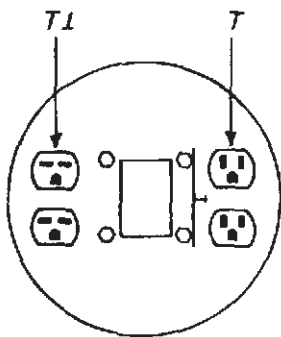

B
DUAL VOLTAGE
MODELS

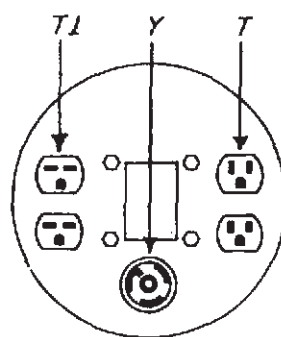

C
DUAL VOLTAGE
WITH EXTRA
RECEPT. CAPACITY

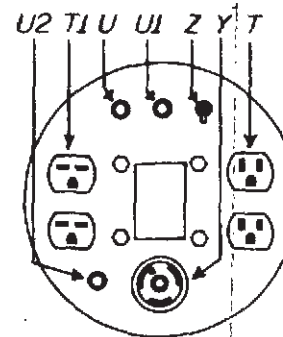

D
DUAL VOLTAGE
W/FULL OUTPUT
SWITCH

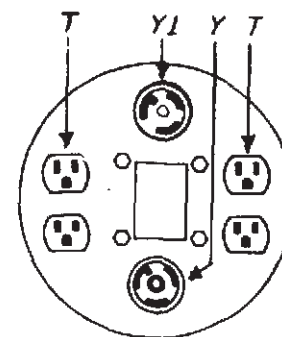

E
FULL WATTAGE
RECEPTACLE
PLATE

PLATE NO.	REF. NO.	PART NO.	REQ'D.	DESCRIPTION
A	T	131	1	15 Amp., 120 V. Duplex Receptacle
	U	132	1	120 V. Indicator Lamp
	U-1	132-A	1	20 Amp. Circuit Breaker, used only on specific models
B	T	131	1	15 Amp., 120 V Duplex Receptacle
	T-1	131-A	1	20 Amp., 240 V. Duplex Receptacle
C	T	131	1	15 Amp., 120 V. Duplex Receptacle
	T-1	131-A	1	20 Amp., 240 V. Duplex Receptacle
	Y	136	1	30 Amp., 120 V. Single, 3-wire Twist-Lock Receptacle
D	T	131	1	15 Amp., 120 V. Duplex Receptacle
	T-1	131-A	1	20 Amp., 240 V. Duplex Receptacle
	U	132	1	120 V. Indicator Lamp
	U-1	132-A	1	20 Amp. Circuit Breaker, used only on specific models
	U-2	132-B	1	30 Amp. Circuit Breaker, used only on specific models
	Y	136	1	30 Amp., 120 V., single, 3-wire twist-lock Receptacle
	Z	137	1	Dual Voltage, Full Power Switch.
E	T	131	1	15 Amp., 120 V. Duplex Receptacle
	T-1	131-A	1	20 Amp., 240 V. Duplex Receptacle
	Y	136	1	30 Amp., 120 V. Single, 3-Wire Twist-lock Receptacle
	Y-1	136-A	1	30 Amp., 240 V. Single, 3-Wire Twist-lock Receptacle

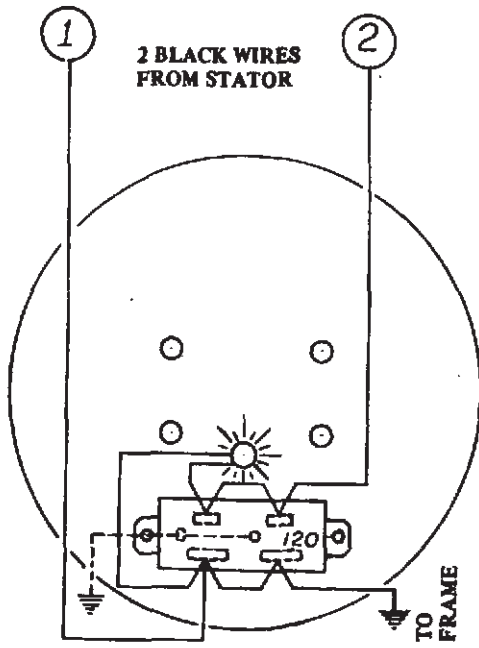

FP - 1 120 V. ONLY
1.2, 1.7, 2.2 KW

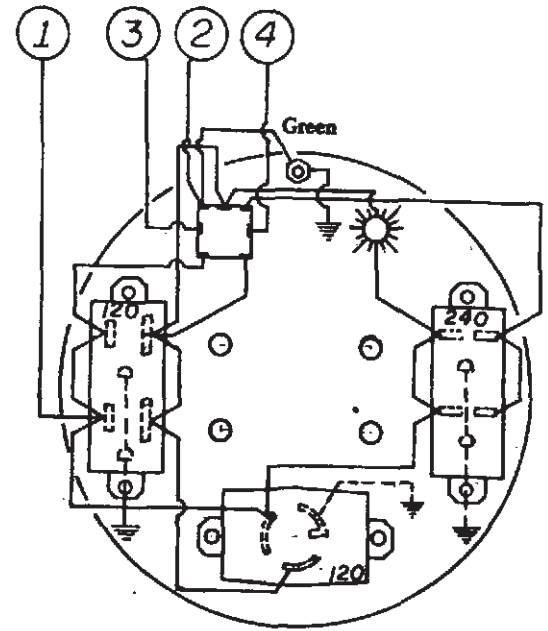

FP - 3 120/240 V. WITH
VOLT SWITCH
3.2, 4, 5 KW

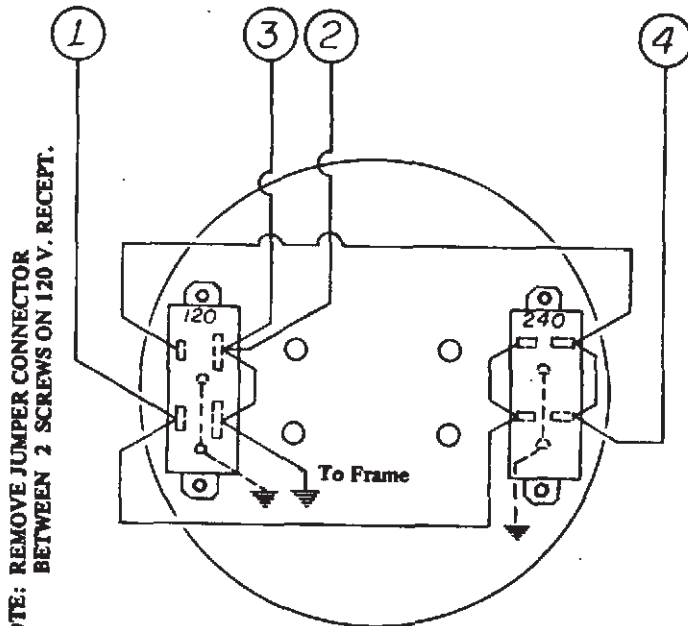

NOTE: REMOVE JUMPER CONNECTOR
BETWEEN 2 SCREWS ON 120 V. RECEPT.

FP - 2 120/240 V.
3.2, 4, 5 KW

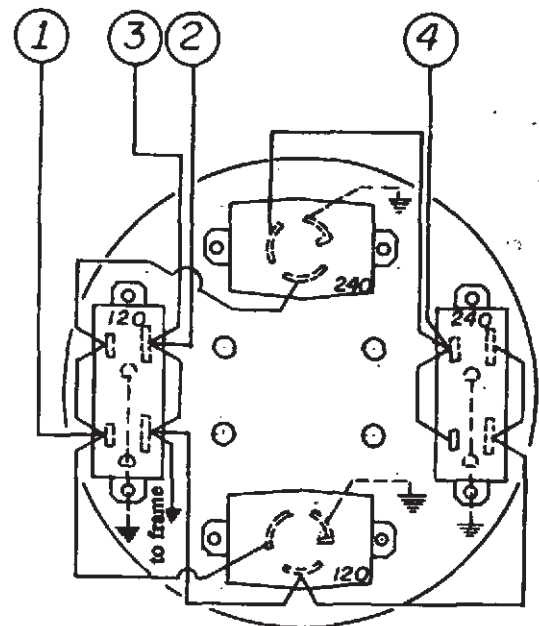

FP - 4 120/240 V.
6.5, 7.5, 8.5 KW

SECTION 7

WATTAGE REQUIREMENTS

HOW TO SIZE THE CORRECT ELECTRIC LOAD TO THE CAPACITY OF YOUR ALTERNATOR:

To begin, determine the minimum amount of appliances, lights and electric motor loads that you require to keep on, if a power blackout would occur. Make two separate lists: one having motors and the other having lights and resistive loads (appliances).

RESISTIVE LOADS:

These electric loads are lights, heater, toasters, radio, television, fans, or other loads not involving electric motors of 1/6 HP or larger. Enter the watts beside each item on your resistive load list. This wattage can usually be found on the nameplate of the item. If not, determine the wattage by multiplying the voltage times the amperage to determine wattage. **EXAMPLE:** Television nameplate rating of 3 amps at 120 volts (3 x 120) equals 360 watts.

ELECTRIC MOTOR LOADS:

These loads present a special problem. They usually require 3 times that of their nameplate ampere rating to start them from a locked rotor position. (Motor is completely stopped.) **EXAMPLE:** A 1/3 HP furnace fan blower motor has a 4 amp rating at 120 volts listed on its nameplate. This becomes 480 watts (4 x 120). Because of its high starting winding current (locked rotor current), you must multiply this running wattage by 3 to size alternator correctly. Thus, the alternator wattage of approximately 1400 should be used. Some motors such as the ones found in saws, drills, food mixers, small fans, hairdryers, etc., require about the same wattage to start as is to run so they do not need the multiplier of 3 and should be considered as resistive type loads.

Add the wattage totals of your resistive load list to the wattages required to start all motors for your total load to be connected to your alternator. Add about 20% to this total for future loads. You may want to add or subtract from your list, at this point, to more closely adjust your load to a specific size alternator output. A special consideration on motor loads is that if there is more than one motor to be started, start one motor at a time and always start the largest horsepower size first. Avoid the starting of two or more motors at the same time. A special caution should be observed when trying to start very special hard starting electric motors such as air compressor and air conditioner motors, submersible pump motors, paint sprayer motors or other special application motors. These motors may require as much as 5 to 7 times their nameplate running amperage in determining the size of alternator to power them.

If you are in doubt, list as much information as you can, such as motor horsepower, voltage, style of motor (split phase, capacitor start, capacitor start and run) amperage rating, design rating, and how it is to be used and consult your alternator distributor or your local, reputable electric motor repair company and ask if they will assist you in determining the correct size alternator (in watts) that you require.

CAUTION: When determining the alternator load, it is critical for you to decide what equipment and/or appliances you want to operate at the same time. You must avoid the common mistake of choosing loads that exceeds the capacity of the alternator. Also care must be taken to try and balance or distribute the electric loads among the proper receptacles. Connecting full load to small receptacle or failure to balance load may result in damage to receptacle and winding.

Consult the following charts for typical wattage ratings.