

GENERATOR AND GENERATOR SET OWNER'S MANUAL

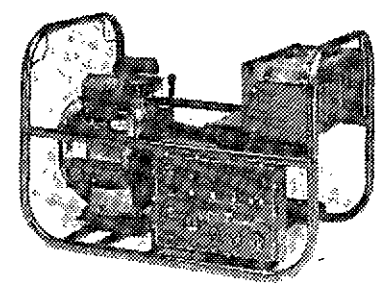

The Use of These Symbols Throughout This Manual Warns of Possible Personal Injury

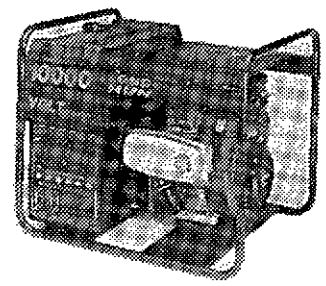
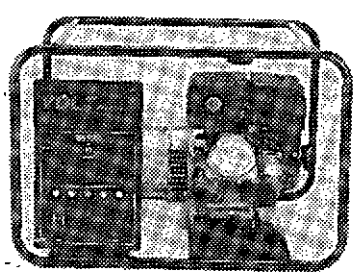
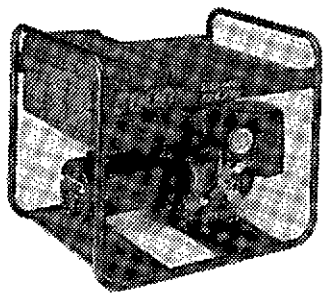
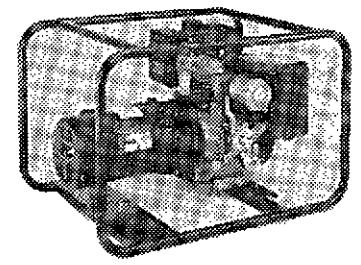
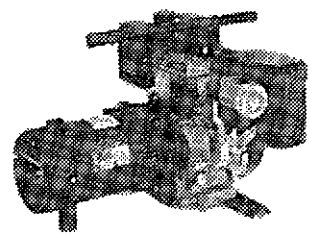
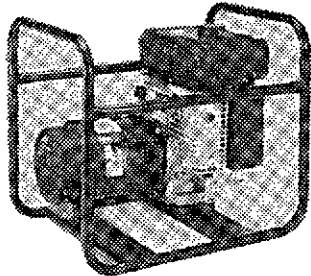
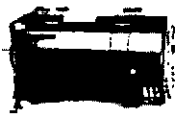

WARNING

This warning symbol identifies specific instructions or procedures which if not correctly followed could result in personal injury or death.

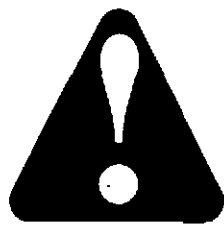

CAUTION

This caution symbol identifies specific instructions or procedures which, if not strictly observed, could result in damage to or destruction of equipment.



WARNING

The Engine Exhaust from this product contains chemicals known to the State of California to cause cancer, birth defects or other reproductive harm

SAFETY FIRST

While safety is built into every generator set, imprudent operation, negligent maintenance or carelessness can contribute to present serious hazards to life and limb. Gasoline and other fuels always present a hazard of possible explosion or fire.

- Keep fuel containers out of reach of children.
- Do not fill fuel tank when engine is running or hot or in darkness.
- Do not smoke or use open flame near generator set fuel tank.
- When fueling electric start models do not touch battery cables or posts with a gasoline supply can.
- Keep a fire extinguisher nearby. Know its proper use. Consult your local fire department for correct extinguisher type.

- Store only in approved containers and in a well ventilated area. Exhaust fumes are poisonous if inhaled.
- Be sure the generator is well ventilated.
- Provide adequate ventilation for the prime mover if it is a gasoline or diesel engine. The output power voltage present in this equipment can cause a fatal electric shock. This equipment must only be operated by a responsible adult.
- Do not allow anyone to operate the generator without proper instruction.
- Guard against electric shock.
- Avoid contact with live terminals or receptacles.
- Use extreme care if operating this unit in rain or snow.
- Only use 3-prong grounded receptacles and extension cords.
- This unit must be properly grounded.
- On construction sites a customer supplied GFCI (Ground Fault Circuit Interruptor) should be utilized to protect the 120-Vac receptacles. When utilizing a lead acid starting battery on electric start models extreme care must be taken when handling or servicing the battery.
- The area must be well ventilated. Lead acid batteries emit a colorless explosive hydrogen gas when being charged.
- Do not smoke while servicing the battery. An open flame can cause an explosion.
- Do not disconnect battery cables on electric start models from the battery or engine while the unit is cranking. Sparks may cause an explosion.
- Only operate this equipment in a well ventilated area.
- Battery acid will cause severe burns and eye damage. Use extreme care when handling or servicing the battery. Hot engine parts and the output of the generator could cause serious injury to the operator. The operator must use caution and remain alert when using this unit.
- All pulleys, belts, etc. should be provided with safety guards.
- Keep all safety guards and power shields in position and tightly secured.
- When working on or around this unit do not wear neckties or loose shirts, jackets, or sleeves that may become caught in moving parts. Only a qualified technician should perform repairs on this equipment.
- Do not work on this equipment while fatigued, under the influence of alcohol or drugs.
- Use extreme caution when working on electrical components. High output voltages from this equipment can cause injury or death.
- When working on this equipment avoid hot mufflers, exhaust manifolds, and engine parts which can cause severe burns. Installing and wiring a home-standby generator installation is not a do it yourself project. Consult a qualified licensed electrician or contractor.
- The installation must comply with all national, state, and local codes. Do not connect generator to home or building except through a double pole double throw transfer switch. Excessive noise is not only tiring, but continual exposure can lead to loss of hearing.
- When working around engines use noise suppression equipment and wear protective devices as necessary.
- Keep your neighbors in mind when noise level is high. Keep generator and surrounding areas clean.
- Remove all grease, ice, snow, or materials that create slippery conditions around the unit.
- Remove oily rags and other material that create potential fire hazards. Consult the local fire department.
- Extinguishers rated ABC by the NFPA are appropriate for all applications. Consult the local fire department.
- Keep extinguisher properly maintained and be familiar with its proper care. The manufacturer recommends that all service including the installation or replacement of service parts be performed only by a qualified electrical serviceman. Use only factory approved repair parts.
- Do not operate this unit in an enclosed compartment such as found in recreational vehicles. All warranties are voided if the unit is operated in an enclosed compartment. Operate only outside in well ventilated area.

VISUAL INSPECTION

Visually inspect the unit before the initial start. Check for loose or missing parts and any damage that may have occurred in shipment.

PRINCIPAL OF OPERATION:

The generator stator in addition to the main phase output winding has an auxiliary phase winding that is connected to a capacitor. The resultant current flow creates an alternating armature reaction that can be considered the combination of two rotating fields.

One field is in the direction of the generator rotation at the same speed. The other is the opposite direction and inducing in the rotor field winding an electro magnetic field double the rated frequency. By connecting a diode in series with the rotor field winding the current is rectified and the necessary excitation obtained. The voltage regulation at load is ensured by the field build-up generated by the armature reactance and by the rotating field windings.

A diode on the main winding permits 12 and 24 volt DC current to be supplied through a rectifier bridge.

MECHANICAL:

This generator is designed as a single bearing generator mounted to the engine by a tapered shaft and a shaft through bolt. Generator rotation is clockwise looking from generator bearing towards engine.

ENGINE OPERATION

NOTE: Read the ENGINE MAINTENANCE section of this manual and the engine manual that comes with the generator before starting or servicing the engine.

ENGINE SERVICING

ON LP/Propane or Natural Gas Fuel units, consult the separate instruction sheet included with each model.

Fill the engine with oil and fuel according to the information given below or the information found in the engine manufacturers instructions.



WARNING

Gasoline is highly explosive. Do not smoke or use open flame when servicing the engine or near the unit mounted fuel tank. To avoid a fire or explosion hazard from spilled fuel, never fill the fuel tank when the engine is running or hot, or in darkness.

Hot engine parts and a hot muffler are potential fire hazards if splashed with fuel. Do not completely fill the fuel tank, as gasoline expands under heat. This could result in fuel splashing onto the hot engine parts, causing possible explosion or fire.



WARNING

On electric start models, use care not to touch the engine starting battery terminals or battery cable connectors with gasoline can or hand tool when servicing the engine. A spark could cause an explosion or fire.

FUEL RECOMMENDATIONS

Our engines will operate satisfactorily on any gasoline intended for automotive use. DO NOT MIX OIL WITH GASOLINE.

We recommend the use of clean, fresh, lead-free gasoline. Leaded gasoline may be used if lead-free is not available. A minimum of 77 octane is recommended. The use of lead-free gasoline results in fewer combustion deposits and longer valve life.

NOTE: We DO NOT recommend the use of gasoline which contains alcohol, such as gasohol. However, if gasoline with alcohol is used, it must not contain more than 10 percent Ethanol and MUST be removed from the engine during storage. DO NOT use gasoline containing Methanol. See STORAGE INSTRUCTIONS. DO NOT fill fuel tank to point of overflowing. Allow approximately 1/4" of tank space for fuel expansion.



CAUTION

DO NOT mix lubricating oil with gasoline.

ENGINE SPECIFICATIONS

	Manual Start	Manual Start	Manual Start	Electric Start	Manual Start	Electric Start	Electric Start	Electric Start
Engine Model	133232	133432	192412	192417	196432	196437	252417	303447
Horse Power*	5	5	8	8	8	8	11	16
RPM*	3600	3600	3600	3600	3600	3600	3600	3600
Displacement (cu.in.)	12.57	12.57	19.44	19.44	19.44	19.44	24.36	29.3
cc.	206	206	319	319	319	319	400	480
Bore (in./mm)	(2.56)65	(2.56)65	(3)76	(3)76	(3)76	(3)76	(3.44)87	(2.69)68
Stroke (in./mm)	(2.44)62	(2.44)62	(2-3/4)70	(2-3/4)70	(2-3/4)70	(2-3/4)70	(2.62)67	(2.60)66
Oil Capacity (pt./l.)	(1.25)59	(1.25)59	(2-3/4)1.3	(2-3/4)1.3	(2-3/4)1.3	(2-3/4)1.3	(3)1.42	(3.5)1.66
Spark Plug Gap (in.)	0.030	0.030	0.030	0.030	0.030	0.030	0.030	.030
Point Setting (in.)	0.020	0.020	0.020	0.020	0.020	0.020	0.020	.020
Valve Clearance (in.)								
Intake	0.006	0.006	0.006	0.006	0.006	0.006	0.006	.006
Exhaust	0.010	0.010	0.010	0.010	0.010	0.010	0.010	.010
Exhaust Outlet (in.)	3/4	3/4	3/4	3/4	3/4	3/4	1	3/4
Fuel Consumption								
Fuel Load (gal./hr.)	0.54	0.54	0.80	0.80	0.80	0.80	1.0	1.34
Fuel Tank Cap. (qt.)	3	3	4 or 6 (IP)	4 or 6 (IP)	6	6	6	32

OIL RECOMMENDATIONS

Note: Engine is shipped **WITHOUT** oil.

Use a high quality detergent oil classified "For Service SF,SE,SD, or SC." Detergent oils keep the engine cleaner and retard the formation of gum and varnish deposits. No special additives should be used with recommended oils.

RECOMMENDED SAE VISCOSITY GRADES

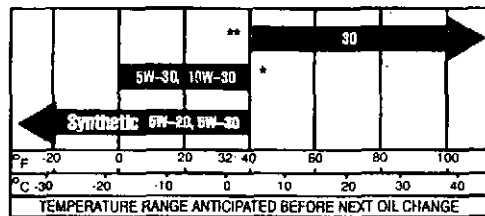

*If not available, a synthetic oil may be used having 5W-20, 5W-30 or 5W-40 viscosity.
NOTE: 10W-40 oil may be used if 10W-30 is not available.

EXTENDED OIL FILL

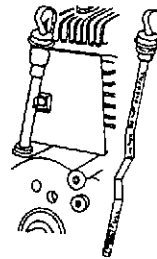
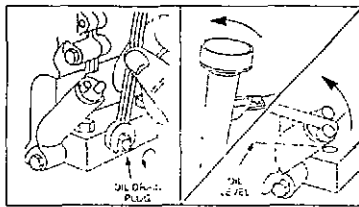
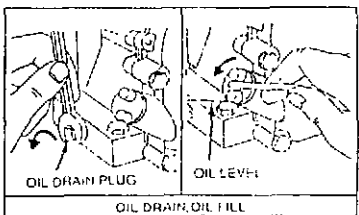

FIGURE 1A 11HP
16HP TWIN
18HP TWIN



5HP



5HP

FIGURE 1

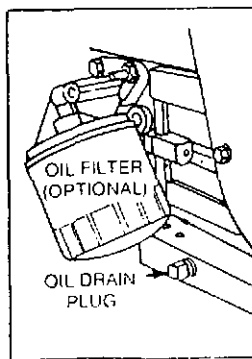

16HP

8 & 11HP

Oil Filling Instructions



Fill the oil sump to overflowing or to full mark on the dip stick (if applicable). (Figures 1 & 1A) Pour slowly to avoid air bubbles. To avoid engine damage always check for full oil level before starting engine. Crankcase pressure can blow hot engine oil out the fill tube causing severe burns, always stop the engine before removing the oil fill cap. Do not overfill the oil level on 13HP, 16HP, 18HP or 24HP engines as damage to engine will occur.

BREAK-IN PROCEDURE

Controlled break-in with the proper grade of lubricating oil helps to ensure satisfactory service from this electric plant. During the first 2-3 hours of operation, do not apply heavy electrical loads to the plant. Oil should be changed after the first 3 hours of operation. The oil changes should then be scheduled at the recommended times shown in the engine manual. Oil should be drained when engine is still slightly warm.

PRE-START

The following only pertains to gasoline fuel models. See separate instruction sheet for LP/Propane and Natural Gas fuel models. The generator must be operated on a firm, dry and clean location. The area must be weather protected and free from heavy dust, sand, dirt, standing water, and snow.



This generator should only be operated by a responsible adult.

Proceed as follows to start the engine:

1. Disconnect all load from the generator.
2. Fully open the fuel valve (Fig.2) if the engine is so equipped. It is located under the unit mounted fuel tank of 8, 11 and 16 HP engines (under fuel tank on LV units).

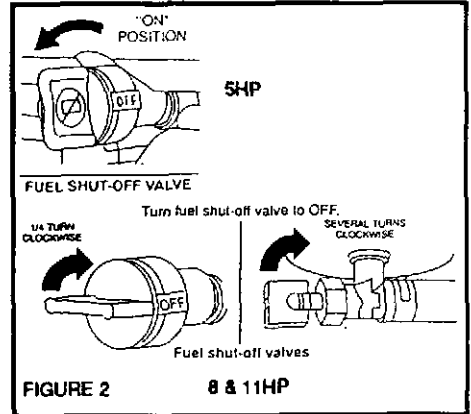
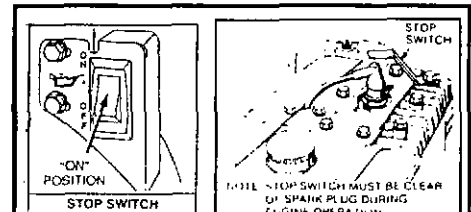
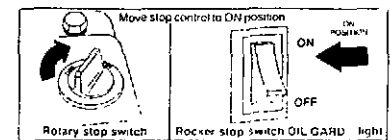

FIGURE 2 8 & 11HP

3. Be sure stop switch is away from spark plug (Fig.3) or slide lever/switch is moved to on position (Fig. 3, 4, 4A, 4B or 4C).



8 & 11HP



16HP

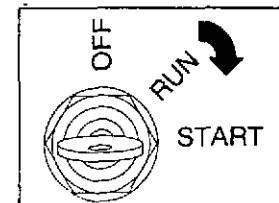

FIGURE 3

4. Adjust the carburetor choke as necessary for temperature conditions. Cold starting requires a full choke (Fig. 4A, 4B or 4C).
5. Engine may be equipped with rope recoil rewind or electric starter. Start engine by referring to the paragraph for the applicable starter.



Avoid touching hot engine parts and the rotating or moving parts of unit.

All fan guards and protective covers must be kept in place. Loose jackets, neckties, etc., should not be worn while starting or operating this generator because of the danger of becoming caught in moving parts. Hot engine parts and mufflers can cause severe burns.

MANUAL START MODELS

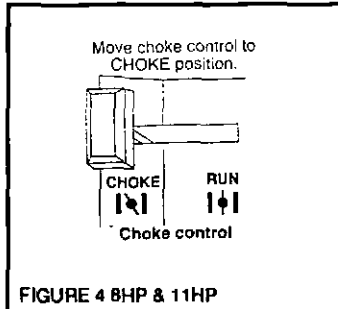

FIGURE 4 8HP & 11HP

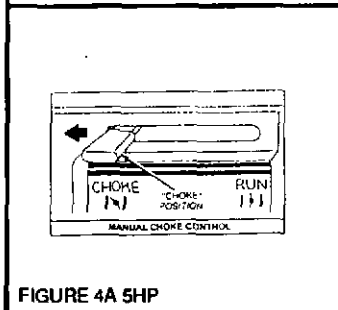

FIGURE 4A 5HP

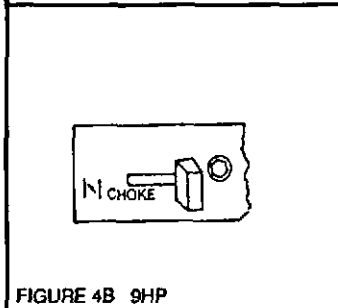

FIGURE 4B 9HP

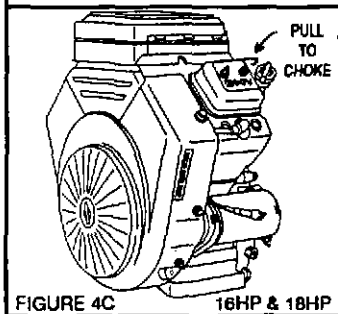

FIGURE 4C 16HP & 18HP

MANUAL RECOIL START MODELS

1. With choke closed (Fig. 5) grasp starter as illustrated in figure and pull out cord rapidly.

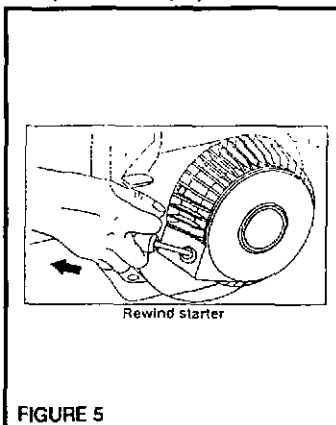

FIGURE 5

2. Repeat if necessary with choke opened slightly. When engine starts, open choke gradually. Do not jerk rope or let it snap back into the rewind mechanism.

ELECTRIC START MODELS STARTING PROCEDURES

Close the choke if engine is cold (Fig. 4 or 4C) and firmly press starter button.

NOTE: The customer must supply the starting battery. Battery and Battery Cables. The factory-supplied battery cables will accommodate a 50 ampere hour, 12-volt DC lead acid battery. The minimum recommended size battery for the electric start generators covered in this manual is 20 ampere hour (160 amp cold cranking.)



Use extreme care not to tilt the unit with the battery installed. Tipping could cause severe eye damage and skin burns.



Battery Installation and Servicing

Be sure battery connections are of the correct polarity. All electric start generators use negative ground, 12-volt DC starting systems. The red cable is positive and the green is negative.



Battery acid will cause severe eye damage and skin burns. Safety glasses must be worn when servicing lead-acid batteries. When connecting or disconnecting battery cables, the engine must not be running or cranking. Batteries give off an explosive gas when being charged. A spark or open flame could result in an explosion.

Safety glasses must be worn when servicing or connecting lead acid batteries. Before connecting cables to the battery the engine must not be running or cranking (engine starting). Batteries give off an explosive gas when being charged by the engine trickle charging circuit. This charging circuit is operational during engine running and cranking. Accidental grounding-out of the battery terminal by tools, gasoline cans, or when installing or removing the battery cables could cause a spark which might result in a battery gas explosion or fire. An open flame or lit cigarette will have the same disastrous effect. Battery terminals and engine starter connections must be clean and tight (Fig. 6).

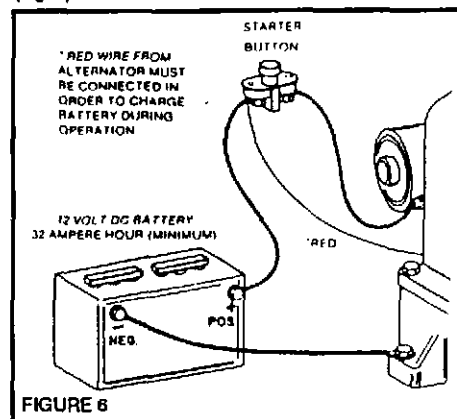

When installing the battery cables, always connect the negative battery cable last. When disconnecting the battery cables, always disconnect the negative cable first. See BATTERY MAINTENANCE section for more information.

Models LV105EH and LV150 require a 12 volt battery to remain connected for engine operation.

STOPPING THE ENGINE - MANUAL AND ELECTRIC MODELS

The following only pertains to gasoline fuel models. See separate instruction sheet for LP/Propane and Natural Gas fuel models.

Gradually remove all the load from the generator, to stop the engine, push the stop switch against the end of the spark plug until the engine comes to a complete stop (Fig. 3 or 7) or turn the key to off.

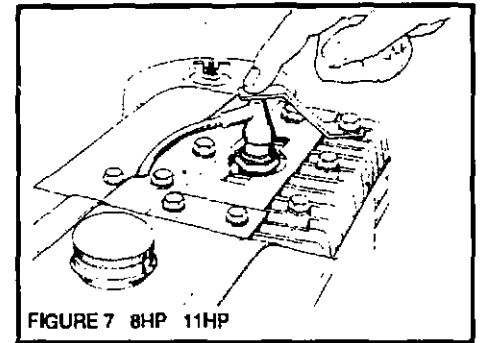

If the switch is released too soon, the engine may continue to run. The engine should be operated at no load for 2 or 3 minutes before stopping the engine to stabilize engine temperatures and insure long engine life. When engine is stopped, close fuel valve (Fig. 2) if engine is so equipped.

GENERATOR OPERATION VENTILATION



Adequate ventilation must be provided for safe efficient operation. The exhaust products of the engine contains invisible carbon monoxide, which is poisonous and can cause death if inhaled. Operation in a truck even with the door open is not recommended.

Only operate this generator outdoors in a well ventilated area. Operation of the generator indoors is not recommended.

OPERATION IN CONFINED SPACES

If generator is operated in a small compartment an engine fire or over heat damage could occur because of restricted or obstructed air flow for proper engine cooling.



Operation in an enclosed compartment is a potential fire or asphyxiation hazard and is not authorized. Mounting this generator in a RV/Motor Home generator compartment could result in a generator set engine fire.

Asphyxiation of the occupants of the RV/Motor Home is also possible because of invisible deadly carbon monoxide gases.

PERMANENT INDOOR INSTALLATIONS

Installing a portable generator indoors is not a do-it-yourself project. A qualified contractor experienced in such installations must be utilized. The contractor must be familiar with engine exhaust piping and muffler installations, provisions, fuel piping and fuel storage, and electrical connections. The contractor must also be familiar with the National Fire Protection Association recommendations and all the local and national codes involved in indoor installations.

Since the factory does not recommend indoor installations, detailed instruction for installing a portable generator indoors is not considered within the scope of this manual.

See HOME STAND-BY INSTALLATION section of this manual for the factory recommended method of using this generator for home standby protection during a utility power failure.

HIGH TEMPERATURE OPERATION

Be sure air flow to and from unit is not obstructed. Keep the unit as free from dirt as possible. Engine air housings must be properly installed and undamaged.

LOW TEMPERATURE OPERATION

To aid in cold weather engine starting use the recommended SAE no. oil for existing temperature conditions. (See Engine Manual).

Preferably, change oil when the engine is still slightly warm. Only use fresh, unleaded gasoline. Protect against moisture condensation and extreme temperatures. If possible keep the generator in a warm location until needed, then carry outside and immediately start engine.

DUST, DIRT, RAIN AND SNOW

Operating this unit in extreme dusty or dirty conditions will seriously affect the life of the engine.

Keep the unit clean. Do not allow snow, rain, dust and dirt to accumulate on the unit. Remove all oil deposits and accumulated dirt. When operating this unit outdoors protect it from the elements.



Use extreme care to avoid a lethal shock hazard if this unit is operating outdoors during periods of visible moisture (rain or snow) or near standing water. Service the air cleaner at least every 25 to 30 operating hours. If

operating in extreme dusty or dirty conditions, service the air cleaner more often and change crankcase oil at least every 25 operating hours. See engine operators' manual.

MUFFLER

The muffler on this generator set is only designed for portable outdoor applications. Indoor operations requires a special muffler, a seamless flexible exhaust connection to protect solid piping from breakage due to engine vibration, solid exhaust piping, and approved exhaust pipe thimble to pass exhaust piping through flammable walls or roofing. Such an installation is beyond the scope of this manual. Consult a qualified contractor familiar with such installations. A damaged or leaky muffler will allow an increased exhaust noise level and increased exhaust gas emissions. A defective muffler should be replaced. Never operate this unit without a muffler.

SPARK ARRESTOR REQUIREMENTS

The muffler included with this generator is not equipped with a spark arrestor. (Except Model LV150)



If this generator is used on any forest covered land, or grass-covered unimproved land, a spark arrestor must be properly attached to the muffler and must be in effective working order.

A U.S.D.A. Forestry Dept. approved spark arrestor kit is offered as optional by the engine manufacturer. When installed the spark arrestor must be firmly attached to the muffler and the screen must be kept clean and unplugged for proper operation. Contact your local engine manufacturer's dealer or distributor for more information. They can be found in your local Yellow Pages under "Engines Gasoline."

Even with the spark arrestor installed, extreme care must still be used if the engine is to be operated in an area of dry forest-covered brush or dry grass which could catch fire from the engine heat or an accidental spark passing through the spark arrestor.

NOTE: If this generator is to be operated in the State of California a spark arrestor must be attached to the exhaust system. The spark arrestor must be properly maintained and in working order to comply with Section 4442 and 4443 of the California Public Resources Code.

GROUND FAULT PROTECTION

The manufacturer recommends the use of a portable GFCI (Ground Fault Circuit Interrupter) when utilizing the 120-volt duplex receptacle on these generators. Portable GFCIS can be purchased at any electrical supply house. See the Yellow Pages under "Electrical Equipment."

UNIT GROUNDING



This unit must be properly grounded to prevent a lethal electrical shock hazard. Only grounded 3-prong plugs must be utilized with the receptacles of this unit. Use only 3-wire extension cords. Use only 3-wire power tools or double insulated power tools.

There is a ground lug or terminal located on the generator. A #10 copper stranded ground wire must be connected to this ground lug and a suitable ground such as a metal stake or ground rod driven into the ground. You must comply with the National Electric Code and all state and local codes.

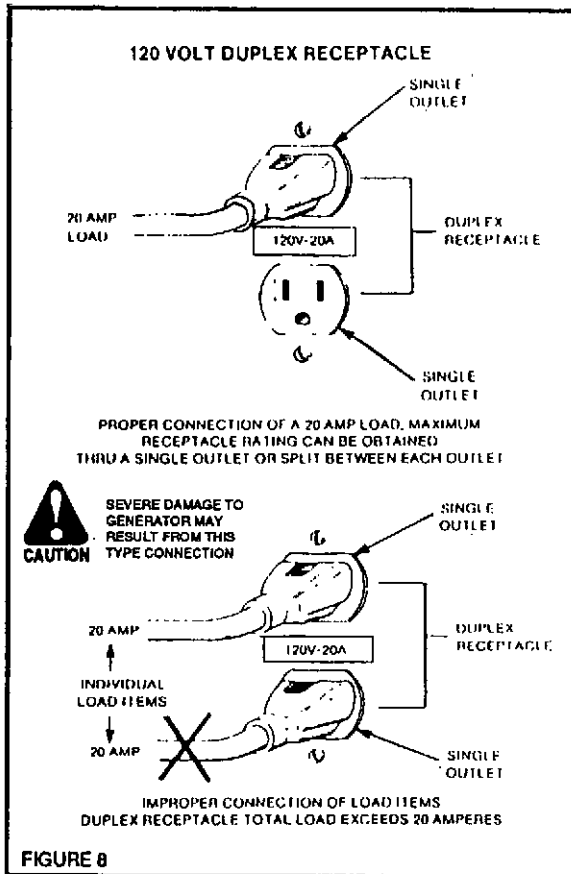

FIGURE 8

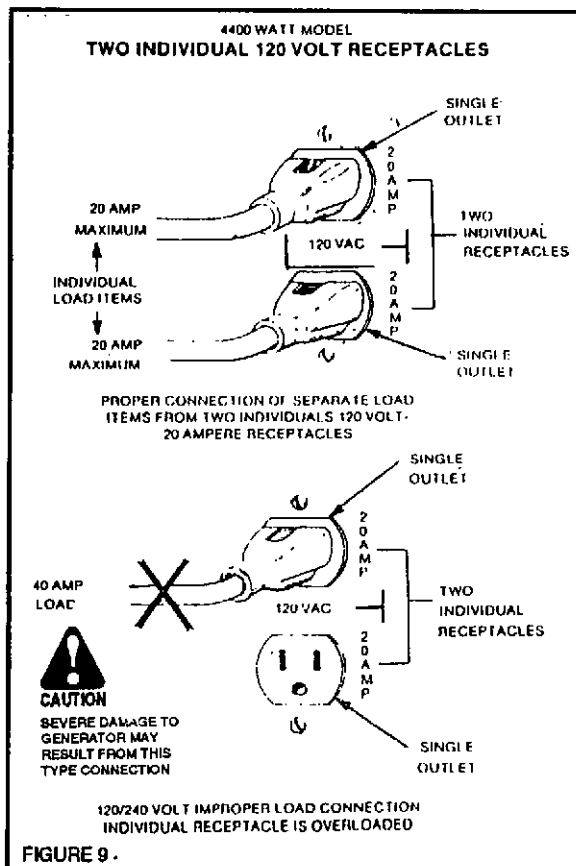

FIGURE 9

APPLYING THE LOAD

Allow the engine to reach normal operating temperature (2-3 minutes) before connecting any load to the generator.

Connect the load by inserting the plugs into the proper receptacles. The load should be applied gradually. If the load consists of large electric motors they should be individually started, the largest first. Then other low demand items can be added to the load.



Keep generator load within the receptacle and generator nameplate rating. Overloading may shorten unit life and could cause internal generator damage. Do not exceed receptacle ampere rating.

The ampere and voltage rating items to be powered by this generator can be found on the nameplate of the electric tool or appliance.

The total output ampere rating stamped on the generator nameplate always refers to the highest voltage the unit is equipped to produce. On 120/240 volt units this should be 240 volts. To determine the total 120-volt ampere rating double the 240-volt amperage provided on the nameplate.

NOTE: The nameplate ampere rating on load items to be powered by this generator can be misleading if they are large power tools or electric motors. These items might require 2-3 times the ampere rating shown on their nameplate to get them started. See wattage requirements for detailed information for figuring the load wattage requirements.

Do not increase engine speed to get more output from generator. Engine will operate at 3600 RPM at full rated load. Racing engine could cause internal damage to the generator.



Excessive engine speed could damage internal components or the generator and will result in excessive generator voltages which could damage items being powered by generator such as TV sets, light bulbs, etc.

DISCONNECTING THE LOAD

The generator is inherently self-regulating and its output automatically adjusts to the load. The generator will not be damaged if it is operated at no load condition. The engine governor will compensate for load variations; therefore, the load can be disconnected in any desired sequence. It is desirable to gradually remove the load if possible. Voltage sensitive load items such as TV and light bulbs should be removed first.

RECEPTACLE UTILIZATION



Do not exceed the amperage rating on the outlet receptacles. This will cause receptacle burnouts and could cause internal damage to the generator. Proper utilization of the outlet receptacles found on this generator is necessary to avoid generator and receptacle damage and to assure satisfactory operation. The operator must realize that this generator is not an unlimited source of power and heed generator and receptacle voltage and ampere ratings. The nameplate ratings can be obtained thru a combination of the receptacles or a single receptacle if the generator and/or the receptacle ampere rating is not exceeded. All plugs on items to be powered from the generator receptacles should be of the 3-prong grounded type. Only 3-wire extension cords and 3-wire or double insulated power tools should be used with the generator. The operator must not overload either the generator or generator receptacles.

240 VOLT RECEPTACLES

4400 watt dual voltage model features a 15-ampere 240-volt duplex receptacle. (Fig. 10)

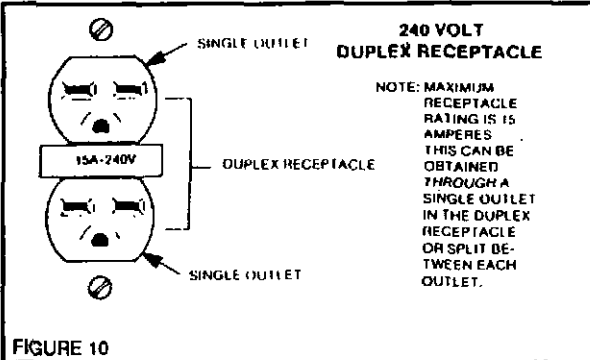

FIGURE 10

All M, LM, LVI, LV150 and LE units feature an easy idle option that automatically reduces engine speed to 2200 to 2400 rpm when there is no electrical load on the generator. The unit should be started with the idler switch in the off position. After the engine has warmed up (2 to 3 minutes), turn the idler switch on. The engine speed will decrease if there is no electrical load on the generator, when an electrical load of 40 watts or more is applied the engine speed will automatically return to normal operating speed and produce the rated voltage.

All M and LM units feature a 120 volt full power switch. When the switch is in the up position (marked 120 volts) the stator windings are connected in a parallel mode making all the output of the generator 120 volts. In this mode the 240 volt receptacle is not functional. This switch should be in this position whenever there is no need for 240 volt output and large 120 volt loads are required such as compressors, pumps, saws, welders etc. If the switch is in the down position, the stator windings are connected in series making all 120 volt and 240 volt receptacles functional. It is recommended to remove electric loads when changing switch positions.

HOME STANDBY INSTALLATIONS

General Information

This generator does not have output capacity to power your entire home. Most home utility commercial electric service is in excess of 75 amperes at 240 volts which will exceed the output of this generator. Because of this, only key items can be powered (up to the ampere rating of the generator) during a utility power outage.

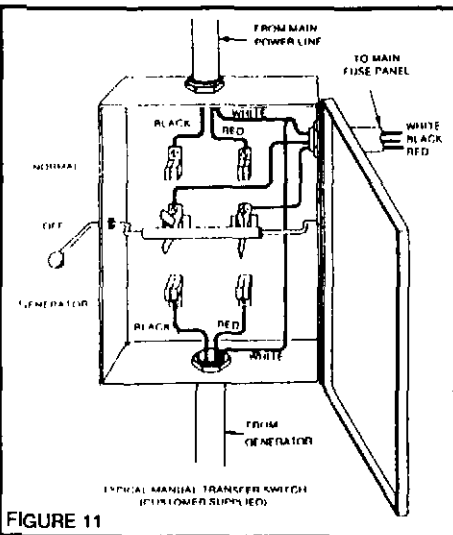

FIGURE 11

GENERATOR AND UTILITY POWER ISOLATION METHODS



If utilizing existing home electric circuits to power the emergency load, provide a positive means of insuring that the commercial power and portable generator powered are never fed to the load at the same time. Never connect the generator output to any live home electric circuit(s). If the generator will be connected to existing home electric circuits during a commercial power outage, a positive means of isolating the commercial and generator power must be provided. The usual means of providing this isolation protection is to incorporate a suitably rated double throw, double pole manual transfer switch (Fig. 11). California law requires isolation of the resident electrical system before connecting a generator to the electrical system. Consult the national electrical code.

A potential hazard exists during a power outage if the generator output is connected to the dead home electric circuits and no means is provided to isolate the home electric circuits from the commercial power source. A power company lineman working to return electric service to normal will open a switch between the main power supply and the spot where he is working. He has every right to believe that the line is dead. If the home electric circuits are not isolated the generator output will backfeed through the home electric circuits up to the power line and the line repairman may be electrocuted when he attempts repairs. If normal power and generator power are not isolated and the normal power is suddenly restored while the generator is still powering the home electric circuits, severe damage to the generator will occur and the possibility of a home electric fire and damage to home electric wiring circuits exists.

SUGGESTED HOME STANDBY INSTALLATION

A typical installation with an outdoor connection box, cord set and manual transfer switch is shown in Figure 12. The installation of the outdoor connection box and manual transfer switch must be performed by a licensed electrician or electrical contractor. The factory does not recommend operating or installing the generator indoors, instead an installation shown in figure 12 is suggested. Store the generator in a warm dry location. During a utility power failure carry it outdoors to a flat dry area such as a drive way or walkway. Use a connection box and cord set (Fig. 12) to connect your home electric circuits to the 240 volt receptacle on your generator. Turn off the lights and appliances that were on before the utility power failure. This prevents

possible overloading of the generator due to immediate demand for a large amount of power. Start the generator and then throw the manual transfer switch to the generator position. Turn load emergency items back on. Be careful not to exceed the output capacity of the generator. When the utility power is restored, throw the manual transfer switch to the normal position. Your home electric circuits are now being powered by your utility. Disconnect the cord set from the connector box and generator. Shut down the generator. When the engine cools down service the engine and place the generator back in its warm, dry storage area.

HOME REWIRING

Any home wiring modification or the installation of a manual transfer switch and outdoor connection box (Fig. 12) must be done by a qualified and licensed electrician.

NOTE: Any permanent wiring installations must comply with the National Electric Code, and all local and state codes.



Installing and wiring a home standby generator system using existing home electric circuits is not a do-it-yourself project. Consult a qualified licensed electrician or electrical contractor.

A) Emergency Circuit Isolation Method:

One method is to have the emergency circuits (important items to be powered in a power outage) grouped together and rewired into a separate junction box (this emergency circuit must not exceed the ampere rating of the generator) and connected to the generator by a cord set or directly wired into the generator. The manual transfer switch with an ampere rating equal to the ampere rating of the emergency circuit, would then be connected between the home load center panel and the emergency circuit junction box (Fig. 13). With this method it will be difficult to accidentally overload the generator. During a power outage, start the generator (with no load) and then place the manual transfer switch in the generator position. The emergency circuits will now be powered by the generator. When the normal power is restored the manual transfer switch should be placed in the normal position after the generator is shut down. The emergency circuits will now be powered by the normal power source.

B) Total Circuit Isolation Method:

If the emergency circuits are not or can not be rewired together in a separate junction box (Fig. 14), you will have to select the circuits and appliances to be powered by the generator. Caution must then be used to prevent the overload of the generator. The manual transfer switch ampere rating must be equal to the ampere rating of the normal incoming utility service. During a power outage start the generator with no load. All items in the home should be turned off. Place the manual transfer switch in the "generator" position. Selected emergency items can then be turned on. Be sure these items don't overload the generator. The emergency items left on home circuits will now be powered by the generator. When the normal power is restored the manual transfer switch is placed in the "normal" position and the generator is shut down. The home electric circuits will now be powered by the utility power source.

* MANUAL TRANSFER SWITCH POSITION DETERMINES WHICH POWER SOURCE, UTILITY OR STANDBY GENERATOR WILL FEED INTO THE DISTRIBUTION PANEL

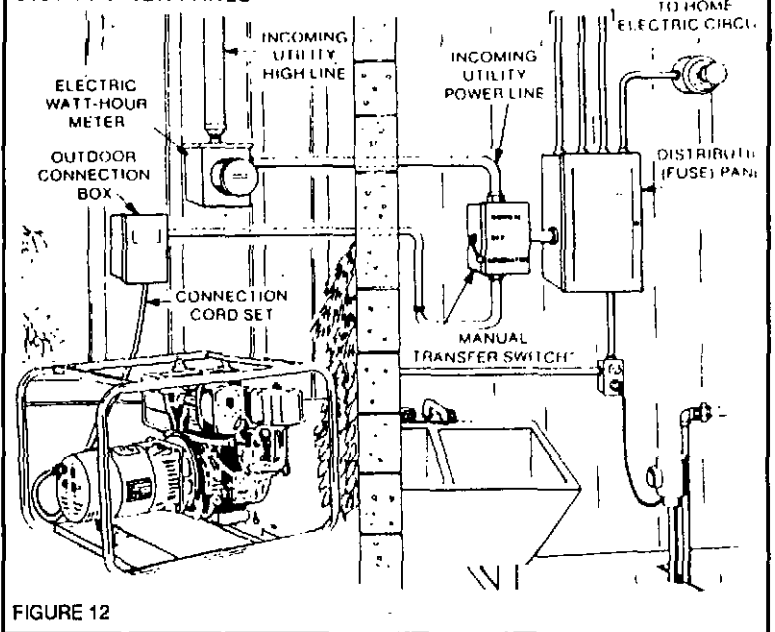
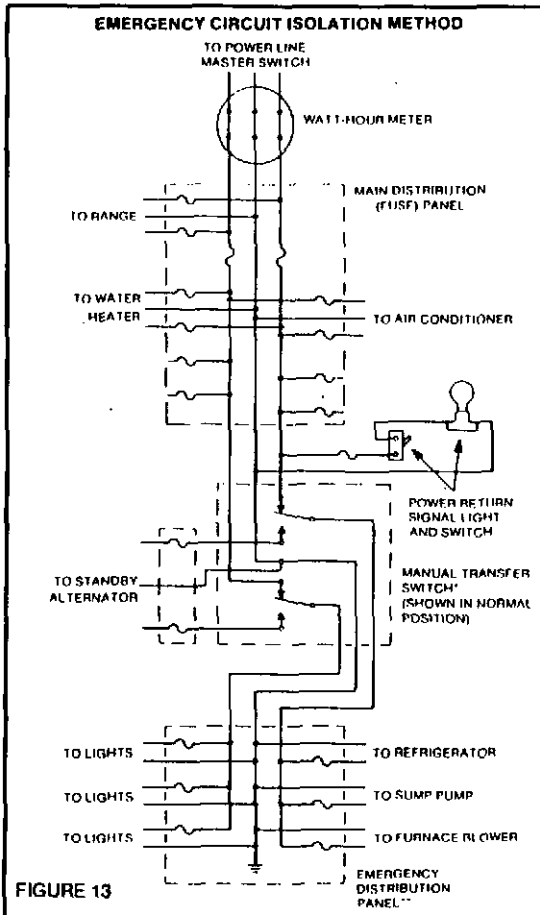
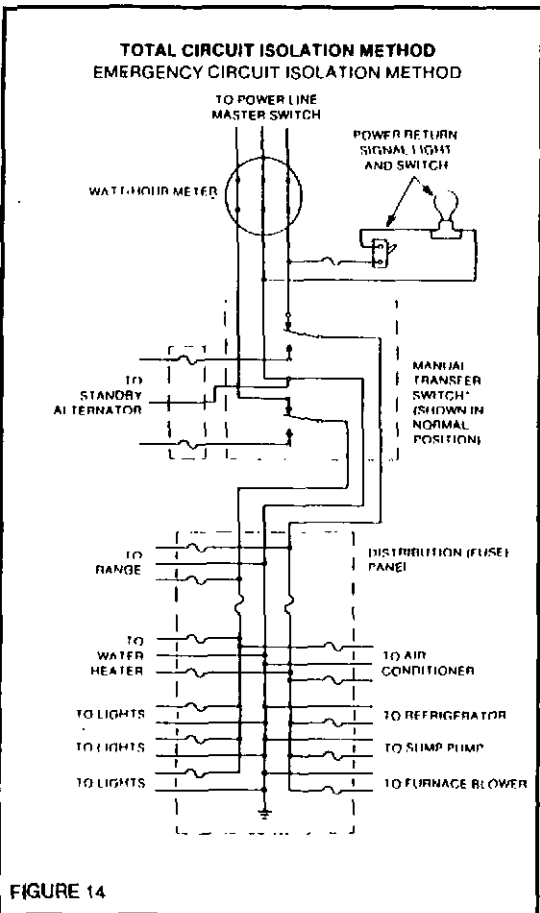

FIGURE 12



- * AMPERE RATING MUST EQUAL OR EXCEED THE AMPERE RATING OF THE EMERGENCY DISTRIBUTION PANEL.
 - ** AMPERE CAPACITY NOT TO EXCEED THE GENERATOR RATING. ONLY THESE ITEMS WILL BE POWERED BY STANDBY GENERATOR. IF ELECTRICIAN SIZES THE LOAD PROPERLY, THE GENERATOR CAN'T BE OVERLOADED.
- ALL WIRING MUST CONFIRM TO NATIONAL ELECTRIC CODES AND ALL STATE AND LOCAL CODES. CONSULT A QUALIFIED, LICENSED ELECTRICIAN.
- THE ILLUSTRATION TO THE SIDE ASSUMES 120/240 VOLT SINGLE PHASE ELECTRIC SERVICE IS BEING SUPPLIED BY THE UTILITY.



NOTE:

WITH THIS SYSTEM, CAUTION MUST BE USED TO PREVENT OVERLOAD OF THE GENERATOR DURING UTILITY POWER FAILURE, ALL LOAD ITEMS IN THE DISTRIBUTION PANEL MUST BE INDIVIDUALLY TURNED OFF. ONLY CERTAIN ITEMS CAN BE TURNED BACK ON DURING GENERATOR OPERATION. THESE ITEMS SHOULD BE SPECIFIED BY YOUR ELECTRICIAN SO AS NOT TO OVERLOAD THE GENERATOR. ALL WIRING MUST CONFORM TO THE NATIONAL ELECTRIC CODE AND ALL STATE AND LOCAL CODES. CONSULT A QUALIFIED LICENSED ELECTRICIAN.

THE ILLUSTRATION TO THE SIDE ASSUMES 120/240 VOLT SINGLE PHASE ELECTRIC SERVICE IS BEING SUPPLIED BY THE UTILITY.

ENGINE MAINTENANCE

If extensive engine service or repair is required contact an authorized engine service station of the engine manufacturer used on this generator. Your nearest engine service center is listed in the Yellow Pages under "Engines, Gasoline" or "Gasoline Engines." The generator manufacturer's warranty does not cover the engine. The engine is covered by the engine manufacturer's warranty. Typical engines used for the generator covered in this manual are shown in figures 15 and 16.

CHECK OIL LEVEL

NOTE: Engine damage due to low oil is not covered by the engine manufacturer's warranty. Oil level should always be checked before starting the engine. Take care to remove dirt around oil filler plug. Be sure oil level is maintained. FILL TO POINT OF OVERFLOWING. **DO NOT OVERFILL VANGUARD 16 H.P. ENGINE.** (Figures 1A, 15 & 16)

INFREQUENT SERVICE

If the unit is used infrequently, extended shut-down periods can result in difficult engine starting. If let to stand in the engine fuel tank for a long period of time, gasoline will tend to form a varnish like substance which will clog up the fuel system and carburetor. The result will be a hard-to-start engine. Check with your local engine manufacturer dealer for his recommendation of a gasoline additive to prevent varnish formations. To eliminate hard starting, run the set at least 30 minutes every 4 to 5 weeks. This will also ensure that the engine seals will not dry out and cause oil leaks and compression problems. The use of a fuel additive such as Sta-bil® or any other equivalent will minimize the formation of gum deposits.

OIL CHANGES

Change oil after first 3 to 5 hours of operation. Thereafter change oil every 25 hours of operation. Remove drain plug and drain oil while engine is warm (Fig. 1A, 15 & 16). Replace drain plug. Remove oil filler plug and refill with new oil of proper grade. Replace oil filler plug.

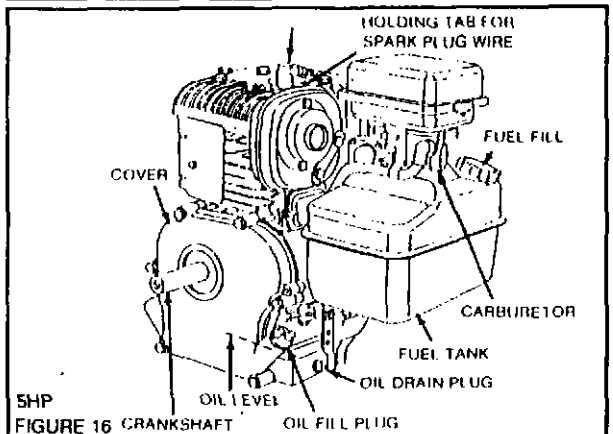
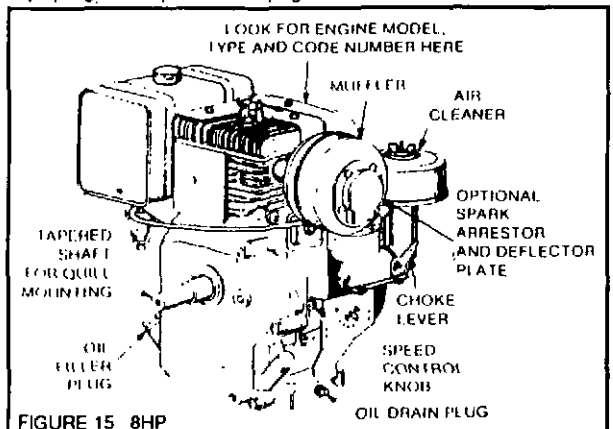

SPARK PLUG

This unit is equipped with a resistor type spark plug to eliminate radio and TV interference from the engine ignition system. Clean and reset gap at 0.030" every 100 hours of operation (Fig. 17). For a replacement spark plug use a champion RC-J8 or Autolite AR-7N resistor type.



Blast cleaning of spark plugs in machines that use abrasive grit is not recommended. Spark plugs should be cleaned by scraping or wire brushing and washing with a chemical solvent or gasoline.

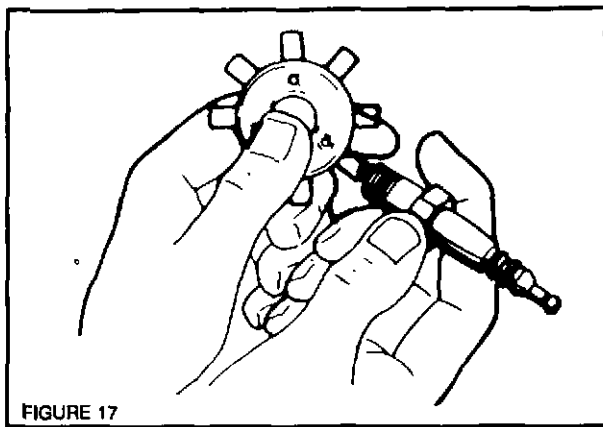

FIGURE 17

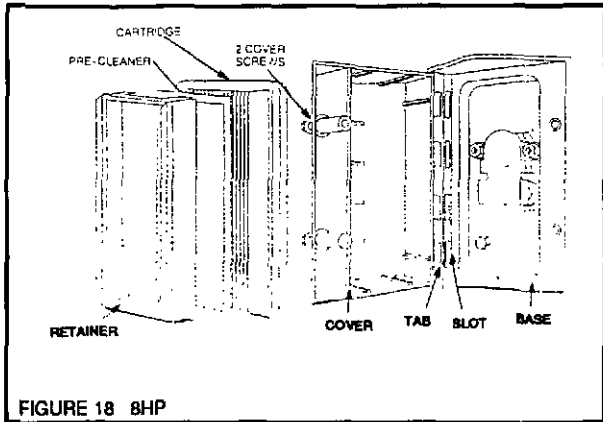

FIGURE 18 8HP

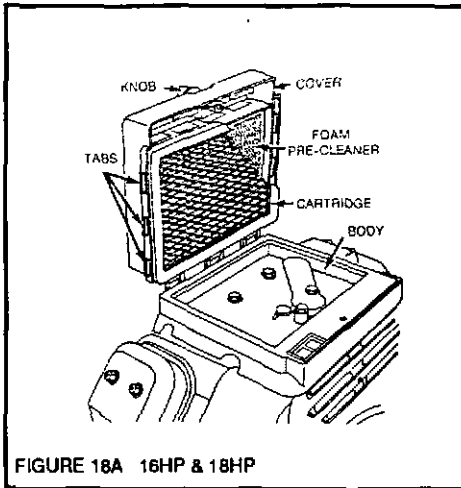

FIGURE 18A 16HP & 18HP

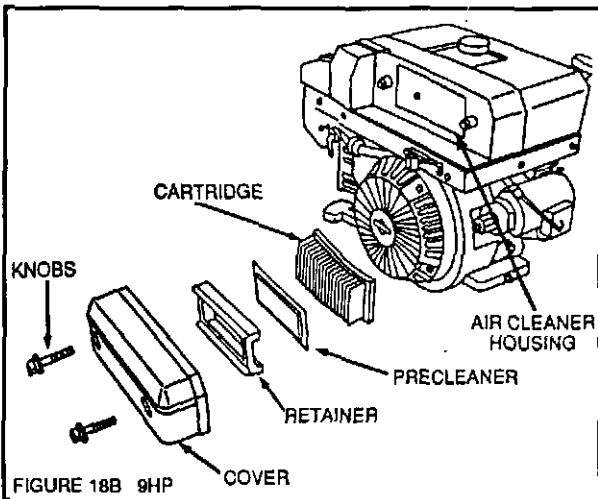

FIGURE 18B 9HP

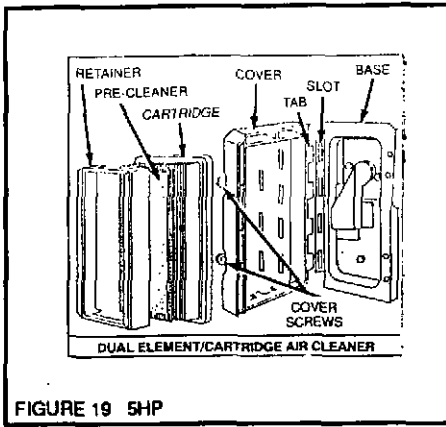

FIGURE 19 5HP

AIR CLEANER

Clean and re-oil air cleaner and element every 25 hours under normal conditions. Clean sooner if operating under extremely dusty conditions.

Instructions: 5HP, 8HP, 11HP, 16HP & 18HP CARTRIDGE AIR CLEANER

1. Loosen screws and lift cover as illustrated. (Fig. 18, 18A, 18B and 19).
2. Carefully remove pre-cleaner (when so equipped) and cartridge.
3. Clean by tapping gently on a flat surface. If very dirty, replace cartridge and pre-cleaner or clean as follows:
 - A. Wash in liquid detergent and water. Saturate in engine oil. Squeeze to remove excess oil. **CAUTION:** do not use petroleum products such as kerosene, to clean cartridge. B. Rinse thoroughly with flowing water from inside out until water is clear.
 - C. Allow cartridge and pre-cleaner (when so equipped) to stand and dry thoroughly before using. **DO NOT OIL CARTRIDGE. DO NOT USE PRESSURIZED AIR TO CLEAN OR DRY CARTRIDGE.**
4. Install cartridge and pre-cleaner (when so equipped) then close cover and fasten screws securely.



CAUTION

CLEAN COOLING SYSTEM

Grass, dirt, or chaff may clog cooling system after prolonged service in dusty or dirty conditions. Continued operation with a clogged cooling system causes severe overheating and possible engine damage. Remove blower housing and clean regularly (Fig. 20)

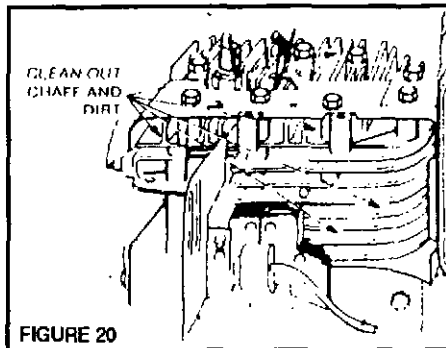

FIGURE 20

CLEAN COMBUSTION CHAMBER

Carbon must be removed from combustion chamber every 200-300 hours of operation. Since engine operates at a constant speed of 3600 RPM and a relatively constant load, the use of regular automotive fuels results in a gradual build-up of deposits in the combustion chamber.

This causes the engine to lose power and prevents the valves from seating properly. Removing the deposits is easy and will pay big dividends in reliability and increased valve life.

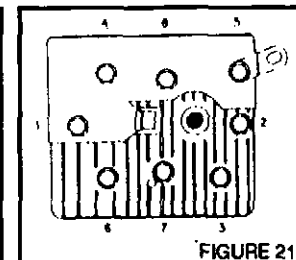

FIGURE 21

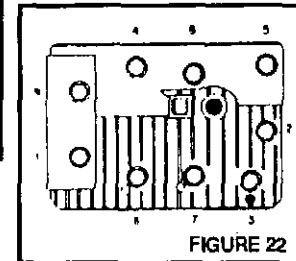

FIGURE 22

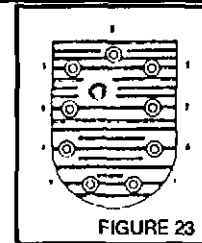

FIGURE 23

1. Remove cylinder head screws noting length and location.
2. Turn crankshaft until piston is at top of cylinder bore and both valves are closed. Scrape and wire brush the carbon deposits from the cylinder head and combustion chamber.
3. Re-use cylinder head gasket only if in good condition. Replace cylinder head. Turn each screw in with wrench until screw head is lightly seated. If a new head gasket is required purchase it from your local Briggs & Stratton dealer.
4. Use socket wrench with 6 inch handle and turn all screws 1/4 turn. Tighten screws in sequence illustrated (Fig. 21, 22 and 23). Run engine approximately 5 minutes and retighten all screws approximately 1/4 turn.

Torques for Briggs & Stratton Engine Cylinder Head Bolts
 5HP 140 inch pounds
 8HP, 11HP & 16HP 165 inch pounds

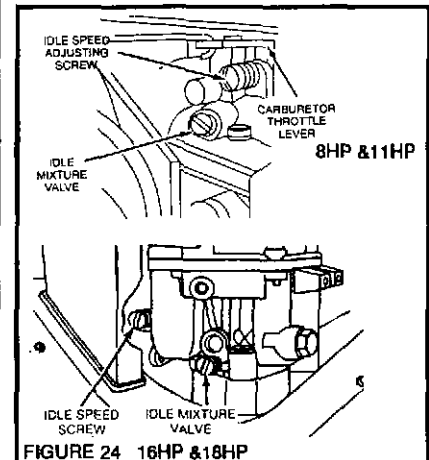

FIGURE 24 16HP & 18HP

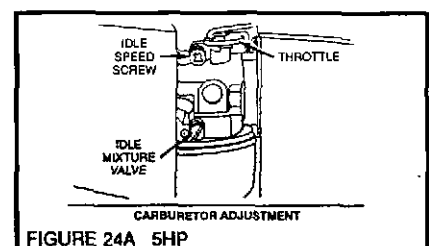
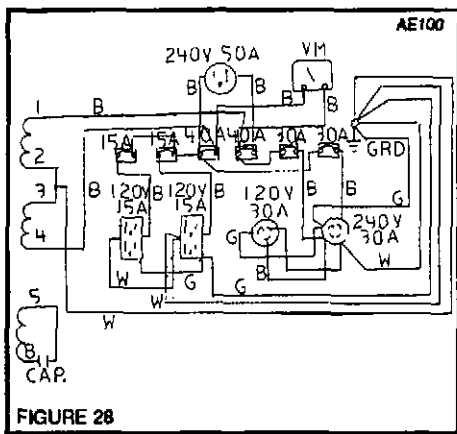
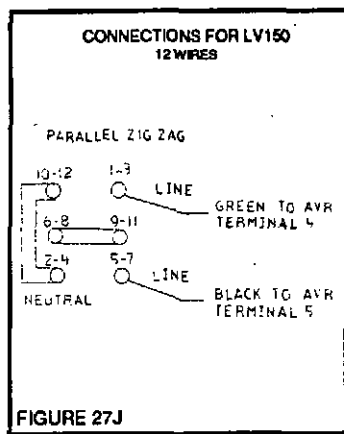
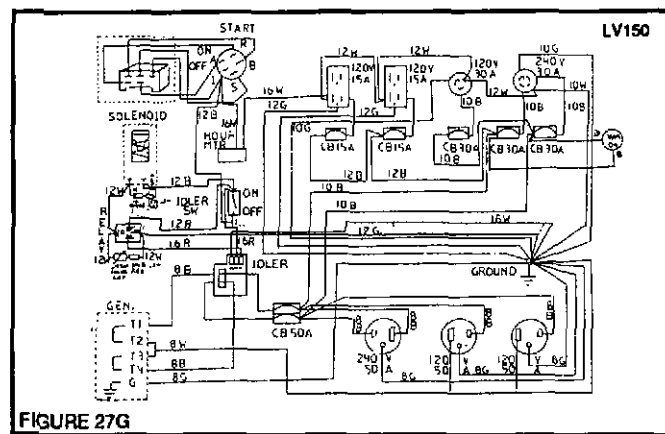
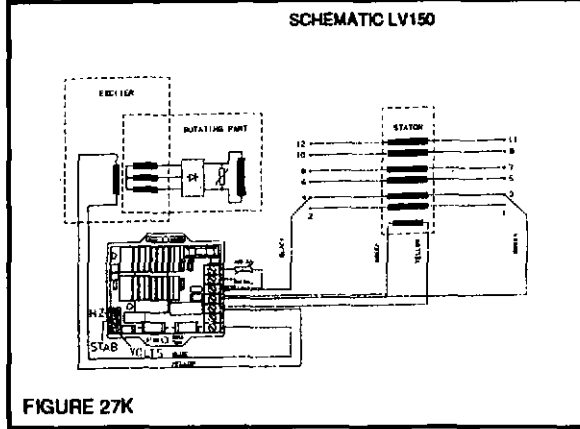
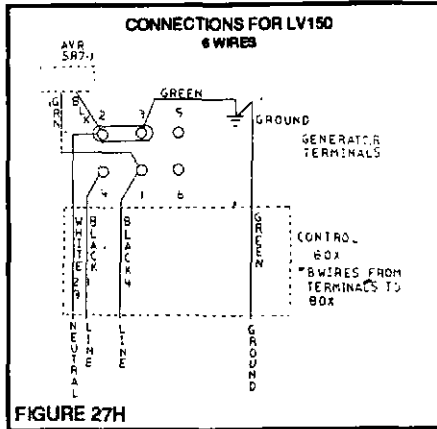
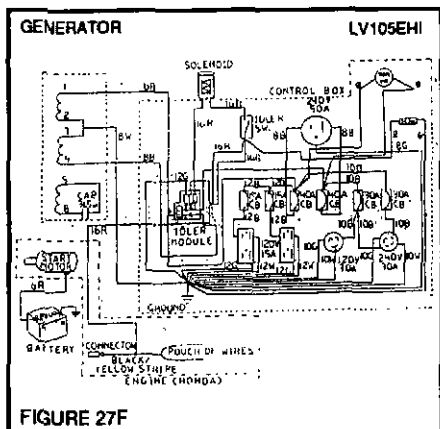

FIGURE 24A 5HP



OUT-OF-SERVICE PROTECTION

If the unit will be out-of-service for more than six months, the following procedures are recommended:

1. Run the unit until it reaches normal operating temperature, 15-30 minutes, then shut it down.
2. Drain the fuel from the carburetor fuel bowl.
3. Drain the oil from the engine base while the engine is still warm. Fill with fresh oil.
4. Remove the spark plug. Pour 1 oz. (two tablespoons) of engine oil into the cylinder. Crank the engine slowly by hand. Reinstall the spark plug but do not tighten.
5. Service the air cleaner.
6. Plug the exhaust outlet to prevent entrance of moisture, bugs and dirt.
7. Clean the entire unit. Coat parts which may rust with a light film of grease or oil.
8. Provide a suitable cover for the unit. Avoid storing the unit where it will be exposed to extreme low or high temperature ambients or excessive moisture.
9. Before restarting, remove all protective material (grease, oil, covers, etc.). Remove spark plug and pull rope starter several times to exhaust excess oil from cylinder.

WATTAGE REQUIREMENTS

Important facts and information on how to determine the load your generator will handle...

When determining the generator load, it is critical for you to decide what equipment and/or appliances you want to operate at the same time. The following 5-step method will help you determine what size load this generator can power. This procedure will help you avoid the mistake of choosing a load that exceeds the capacity of the generator. Electric motors present a special problem when figuring the proper generator size, so please read step 3 very carefully.

Here's how to determine the load...

1. Make two lists, one of the electrical motors and the other of all the lights, small appliances, etc. that must be powered by the portable generator. For stand-by emergency service you should only include essential equipment (refrigerator, sump pump, etc.) which must be kept in operation.
2. Enter the watts required to operate each item (except motors, see step 3). This wattage figure can usually be found on the light bulb or appliance nameplate. If the wattage is not listed, you can determine the wattage by

multiplying the amperage by the voltage (both figures are found on appliance nameplate). NOTE-the formula for finding wattage is voltage x amperage = wattage.

3. Electric motors present a special problem. They usually require 3-4 times their nameplate amperage or wattage to start them from a locked condition (motor completely stopped). For example: if the electric motor's nameplate states 10 amps at 120 volts, the 10x20=2000 watts running. This figure has to be multiplied by three times to figure the starting watts needed. In this example that would be 3600 watts. The starting watts figure is the one that must be used, not the nameplate or running watts figure, when figuring the load to be powered by the generator.

IMPORTANT- Air compressors, circular saws, 1/2" drills, submersible pumps and air conditioners require heavy motor starting current (this means at least three (3) times the nameplate amps or wattage). These items are typically rated at 10 amps or 1200 watts running on 120 volt circuits. This means these items require a single circuit rated at least 30 amps at 120 volts. Before starting these devices with your generator check that your generator has a single circuit of 30 amps at 120 volts. Units rated up to and including 4400 watts of continuous output are not usually wired for more than 20 amps on a single outlet. Units rated at 4400 watts or above can easily be rewired or have at least 30 amps on a single 120 volt outlet. Overloading a circuit may result in permanent damage to unit which is not covered under warranty.

Consult factory for reconnecting to straight 120 volts see back cover.

NOTE: Some motors, such as those used in hair dryers, food mixers, etc. require approximately the same wattage to run as to start. See chart below for some examples or check appliance nameplate for wattage.

4. Add the watts required for those items in step 4 to cover forgotten items. Special notes: If more than one motor is to be started, start one motor at a time and always start the largest first. If trying to take the entire load of the generator from a single generator receptacle, be sure the ampere rating of the receptacle is not exceeded.

Typical Motor Wattage

For motor-driven electric appliances and equipment such as refrigerators, washing machines, air conditioners, pumps,

oil burners, furnace blowers, barn cleaners sump pumps, check the typical motor wattage requirements listed in chart below. This chart is a guide but always check your specific motors for actual requirements.

RECOMMENDED EXTENSION CORDS

FOR USE WITH GENERATORS

It is important to use extension cords of adequate current carrying capacity when utilizing a generator to operate portable electric tools. Undersized cords result in excessive voltage drops and additional power plant loading. This also causes excessive heating of the portable tool because voltage drop reduces tool capacity.

TYPICAL ELECTRIC APPLIANCE WATTAGE	ESTIMATED RUNNING WATTS
Electric Motor (2 hp)	4500
Concrete Vibrator (3 hp)	4500
Air Conditioner (12,000 BTU)	3250
Radial Arm Saw	2600
Submersible Pump (1 hp)	2000
Electric Range (1 element)	2000
Electric Sledge	1500
Furnace Fan (1/3 hp)	1250
Chain Saw	1200
Circular Saw (6 1/2")	1200
Toaster	1200
Coffee Maker	1100
Microwave Oven	1000
Sump Pump	700
Airless Sprayer (1/3 hp)	600
Small Refrigerator/Freezer	600
Hand Drill (1/4")	600
Deep Freezer	540
Television	500
Wood Trimmer	500
Hedge Trimmer	450
Slow Cooker	200
12V DC Battery Charger	120
Light Bulb	100

WIRE GAUGE @ CORD LENGTH			
Ampere Rating	50ft.	100ft.	150ft.
2	18	18	18
3	18	18	18
4	16	16	16
5	16	16	16
6	16	16	14
8	16	14	12
10	16	14	12
12	14	14	12
14	14	12	10
16	12	12	10

LV70EH, LV80E AND LV105E

REF. NO.	PART NO.	DESCRIPTION	QTY. LV70EH	QTY. LV80E	QTY. LV105E
A	2156	BEARING BRACKET	1	1	
B	2153	STATOR	1		
B	2163	STATOR		1	
C	2158	GEN COVER	1		
C	-	GEN COVER		1	
D	2157	GEN BRACKET	1	1	
E	-	SHEET METAL SCREW	4	4	
F	-	FAN COVER	1	1	
G	2181	BEARING	1	1	
H	2150	ROTOR LV80	1		
H	2182	ROTOR LV105		1	
J	2151	FAN	1	1	
K	2827	3/8 - 18 x 1-1/8 SOCKET HEAD SCREW	4	4	
M	1022	3/8 LOCKWASHER	4	4	
N	2156	ENGINE BRACKET	1	1	
P	2146	ENGINE 18HP VANGUARD 18HP HONDA	1	1	
Q	1020	5/16 - 18 KEPS NUT	10	10	
R	2216	BUMPER WITH STUD	6	6	
S	2133	ROTOR SCREW	1	1	
T	2190	DIODE IR21PT80 WITH SUPPRESSOR	2	2	
U	-	HEX BOLT	4	4	
V	-	PHILLIPS SHEET METAL SCREW	4	4	
W	1101	RECEPTACLE 250V, 30A T/L	1	1	
X	1069	CIRCUIT BREAKER 20A	1	2	
X	1112	CIRCUIT BREAKER 30A	3	2	
Y	1117	RECEPTACLE 125V, 30A T/L	1	2	
Z	1011	RECEPTACLE 125V, 20A	1	1	

LV70EHI, LV80EI, LV105EI AND LV105EHI

PARTS LIST

REF. NO.	PART NO.	DESCRIPTION	QTY. LV70EH	QTY. LV80E	QTY. LV105E	QTY. LV70EHI	QTY. LV80EHI	QTY. LV105EHI
AA	1018	8 - 32 x 1/2 PHILLIPS SCREW	8	8		8	8	
BB	1072	8 - 32 KEPS NUT	8	8		8	8	
CC	1013	BATTERY CABLE GREEN	1	1		1	1	
DD	1014	BATTERY CABLE RED	1	1		1	1	
EE	1027	1/4 - 20 KEPS NUT	6	6		6	6	
FF	2012	3/4 x 5/16 WASHER	4	4		4	4	
GG	2886	GAS CAP	1	1		1	1	
HH	2922	FUEL TANK	1	1		1	1	
JJ	2935	FRAME WITH DEFLECTOR	1	1		1	1	
KK	2013	FUEL LINE	36"	36"		36"	36"	
MM	1034	GROUND LUG	1	1		1	1	
NN	2567	FOOT	2	2		2	2	
PP	2160	CONTROL PANEL	1			1		
PP	2633	CONTROL PANEL		1			1	
QQ	1026	5/16 x 1-1/2 FLAT WASHER	8	8		8	8	
RR	2145	CAPICITOR 25MF	1	1		1	1	
SS	2159	BRACKET	1	1		1	1	
TT	2154	STATOR BOLT	4			4		
TT	2164	STATOR BOLT		4			4	
UU	2881	BRACKET L				1	1	
VV	2879	CONTROL BOX				1	1	
WW	2891	HOUR METER						
XX	2024	VOLTMETER						
YY	2904	RECEPTACLE 250V,50A						1
ZZ	2034	SWITCH				1	1	
AAA	2882	CIRCUIT BREAKER 40A						2
BBB	2726	SOLENOID				1	1	
CCC	2946	SOLENOID BRACKET VANGUARD				1	1	
CCC	3008	SOLENOID BRACKET HONDA						1
DDD	-	SOLENOID LINKAGE				1	1	
EEE	2880-8	FRONT COVER				1		
EEE	2880-10	FRONT COVER						1
FFF	2388	1/4"-20 X3/4" HEX NUT				7	7	
GGG	2937-D	COVER DEFLECTOR				1	1	
HHH	2460	RECEPTACLE 120V, 15A GFI				2	2	

LV70EH, LV80E AND LV105E
LV70EHI, LV80EI, LV105EI AND LV105EHI

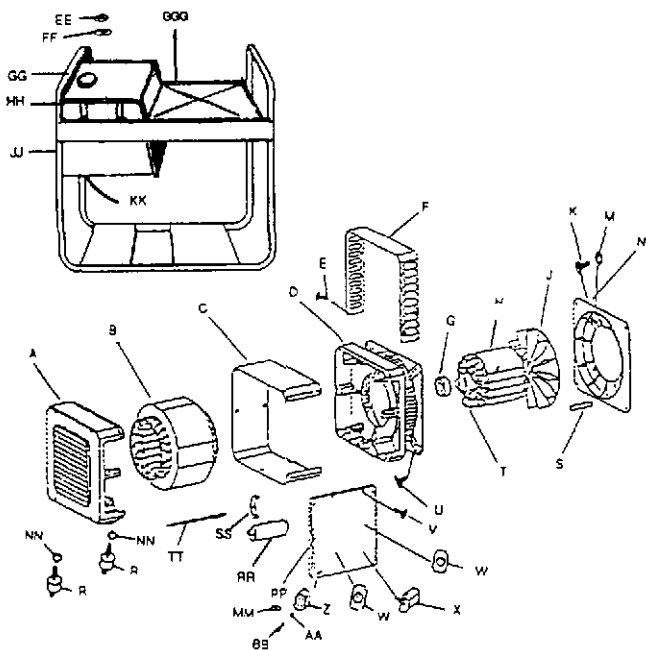

LE70EH, LE80E, LE105E

LE70EHI, LE80EI, LE105EI AND LE105EHI

REF. NO.	PART NO.	DESCRIPTION	QTY. LE70E	QTY. LE80E	QTY. LE105E	QTY. LE70EHI	QTY. LE80EHI	QTY. LE105EHI
JJJ	3202	TOP COVER	1	1		1	1	
KKK	2615	BEARING 52MM	1	1		1	1	
MMM	3183	ROTOR E100		1				1
MMM	3194	ROTOR E80	1			1		
NNN	3189	FAN	1	1		1	1	
PPP	3195	ENGINE BRACKET E100		1				1
QQQ	3196	ROTOR SCREW E100		1				1
QQQ	3197	ROTOR SCREW E80	1			1		
RRR	3198	WASHER E100	1	1		1	1	
SSS	3199	NUT E100	1	1		1	1	
TTT	3183	STATOR AND HOUSING E100		1				1
TTT	3200	STATOR AND HOUSING E80	1			1		
UUU	3201	END COVER E100		1				1
VVV	3184	TERMINAL STRIP	1	1		1	1	
WWW	3188	CAPACITORS 92MF						
XXX	3190	DIODE W/SUPP.	2	2		2	2	
YYY	2174	CROSS CHANNEL		2				2

LE70EH, LE80E, LE105E

LE70EHI, LE80EI, LE105EI AND LE105EHI

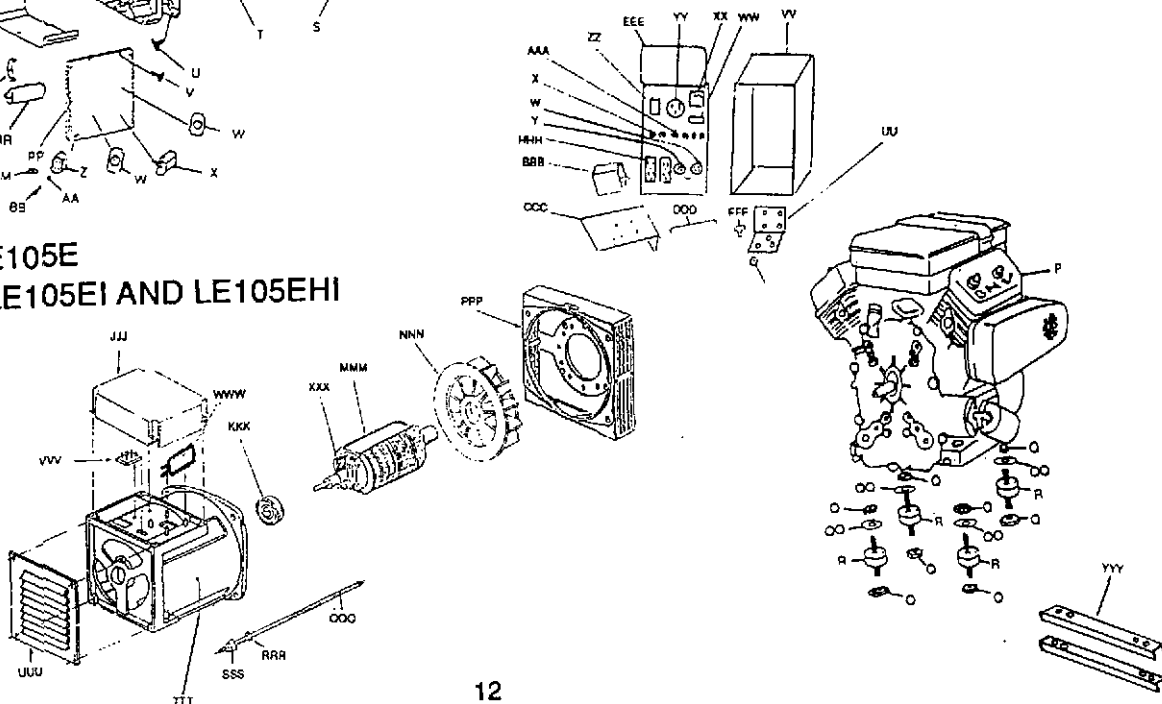

REF. NO.	PART NO.	DESCRIPTION	QTY.
A	3084	LOUVERED COVER	1
B	3087	BEARING BRACKET	1
C	3088	VOLTAGE REG SR7/1	1
D	3089	TERMINAL BOARD	1
E	3090	EXCITER STATOR	1
F	3091	MAIN STATOR	1
G	3092	FAN SCREEN	1
H	3093	ENGINE BRACKET	1
J	2845	ENGINE ONAN 24HP	1
K	—	SOLENOID	1
M	3095	STATOR BOLT	4
N	3096	FAN	1
P	3097	MAIN ROTOR	1
Q	3098	EXCITER ARMATURE	1
R	3099	VARIATER BY255	6
S	3100	DIODE V275LA20A	6
T	3101	BEARING 6305-2RS	1
U	3102	ROTOR BOLT&NUT	1
V	3103	ROTOR NUT COVER	1
W	2886	GAS CAP	1
X	2822	FUEL TANK	1

REF. NO.	PART NO.	DESCRIPTION	QTY.
Y	2915	FRAME	1
Z	1117	RECEPT TL 120V30A	1
AA	1101	RECEPT TL 240V30A	1
BB	1112	CIRCUIT BREAKER 30A	3
CC	2901	CONTROL BOX	1
DD	2900	FRONT COVER	1
EE	2456	RECEPT 120V,50A	2
FF	2904	RECEPT 240V,50A	1
GG	3015	CIRCUIT BREAKER 50A	1
HH	2034	SWITCH IDLER	1
JJ	2891	HOUR METER	1
KK	2889	CHOKE KNOB/CABLE	1
MM	2890	SWITCH START/STOP	1
NN	1070	CIRCUIT BREAKER 15A	2
PP	2480	RECEPT 120V15AGFI	2
QQ	2909	VIBRATION MOUNTS	6
RR	1094	HOLD DOWN STRAP	1
SS	2951	MUFFLER	1
TT	2915-D	DEFLECTOR/TANK	1
UU	2900DH	DEFLECTOR CONTROL B	1
VV	3021	MUFFLER BRACKET	1
WW	2915-B	GENERATOR FOOT	1
XX	1014	BATTERY CABLE RED	1
YY	1013	BATTERY CABLE GREEN	1

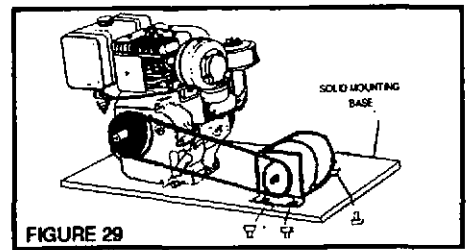

FIGURE 29
TYPICAL INSTALLATION SHOWN WITH BELT GUARD REMOVED

V-BELT TRANSMISSIONS

• Keep the pulley close to the engine. The outer edge of the pulley should not extend more than 50mm (2in) past the end of the crankshaft. Greater distances will stress the shaft and shaft bearings.

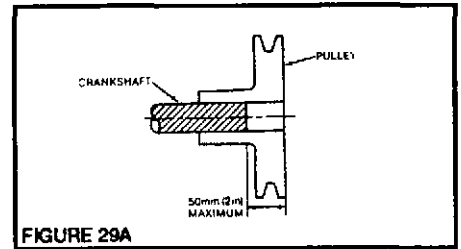

FIGURE 29A

• Avoid using an idler pulley whenever possible. If an idler must be used, install it on the slack run of the belt.

• If a belt tensioner is used, it should also be installed on the slack run of the belt. If the tensioner is used as a drive clutch, you may need to install a brake at the driven pulley to prevent driven pulley rotation while belt tension is released.

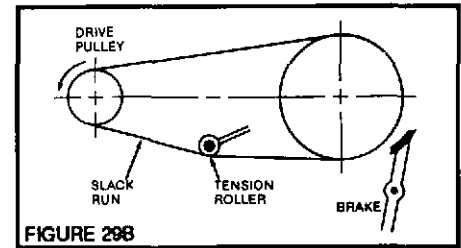

FIGURE 29B

• Smaller diameter pulleys require more belt tension to deliver equal horsepower. To reduce the belt's load on the crankshaft and bearings, be sure to observe the pulley size requirements.

DETERMINING PULLEY DIAMETER

The smaller the pulley diameter, the greater the stress on the belt. Transmission efficiency decreases and belt wear increases, so that belt life is considerably shortened.

For A-type belts used with engines of 5HP or less, the minimum pulley outer diameter should be 80mm; for A-type belts used with engines of more than 5HP, the pulley should be at least 90mm; for B-type belt applications, the pulley outer diameter should be 120mm minimum.

Note the difference between the pulley outer diameter and effective diameter:
(outer diameter) - (belt thickness) = (effective diameter)

DETERMINING BELT TENSION

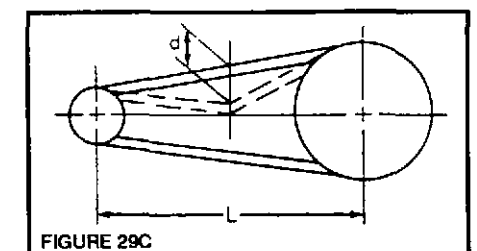
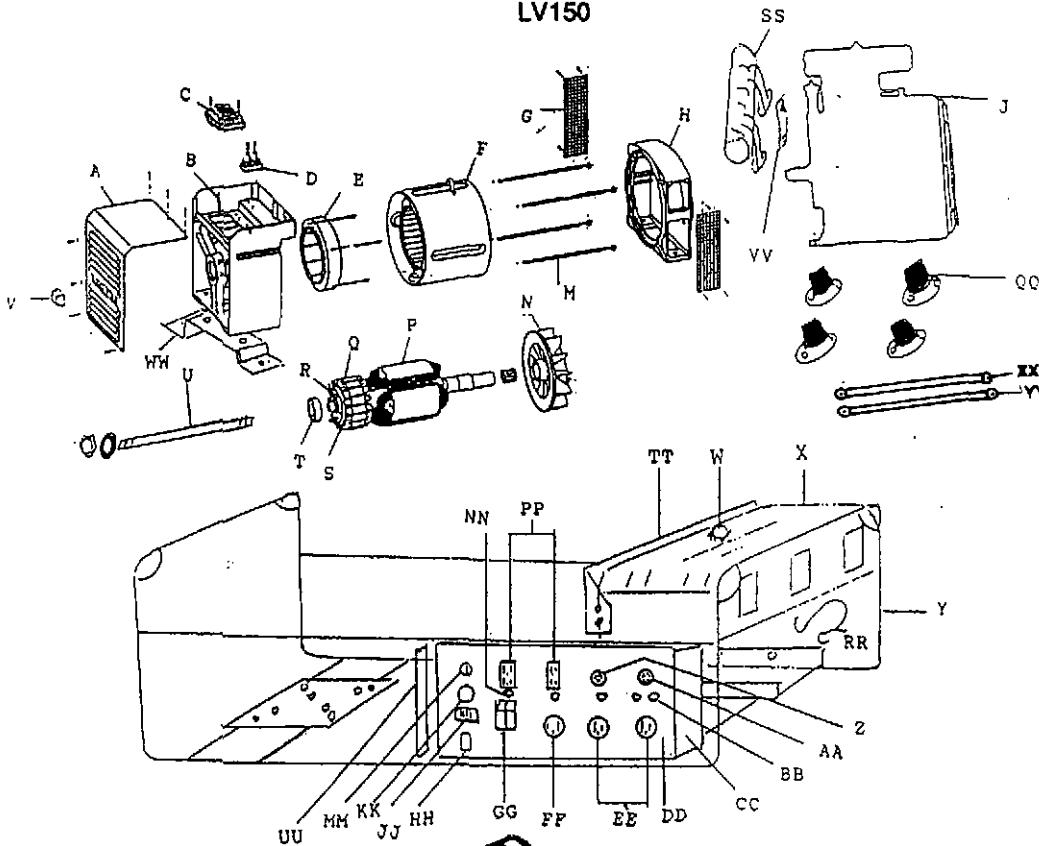

FIGURE 29C

Push the belt midway between the pulleys, check the direction (d) and adjust:
 $d = 0.016 \times L$

LV150



AB25, 50, 60 & AE100

The pulley driven MODELS AB25, 50 & 60 operate in a clockwise direction when viewed from the shaft. Operation in a counter clockwise direction will result in damage to the generator. MODEL AE100 operates clockwise or counter clockwise.



INSTALLATION

The mounting base must be securely mounted to the same base as the engine which will drive the generator. Failure to mount securely will cause the generator to lift up rapidly and cause personal injury to people nearby. As pulleys must be installed on both the engine and generator, they must be covered with a guard to prevent personal injury. Never operate the engine/generator combination without all rotating parts covered. Safety guards and pulley are not provided as the generator manufacturer does not know size and dimensions of the users engine.



OPERATION

This generator must operate at a shaft speed of 3600 RPM. To set the shaft speed of the generator use a Tachometer. If a tachometer is not available, use a voltmeter plugged into the 120 volt receptacle, on reaching 120 volts the proper generator shaft speed of 3600 RPM has been obtained.



Underspeed (low voltage) or overspeed (high voltage) of the generator may result in electrical damage to the generator and/or the devices being run by the generator. Over tensioning of the pulley will result in damage to the generator. Always start the generator set and reach proper RPM / Voltage before applying a load to the generator. To obtain full electrical output, an engine of at least 5HP must be used for the AB25, 8HP for AB50, 11HP for the AB60, and 16HP for AE100. The generator shaft is 7/8" O.D. with a 3/16" keyway, on AB25, 50, and 60. The generator shaft is 1" O.D. with 1/4" keyway on AE100.

AB25 PARTS LIST

REF. NO.	PART NO.	DESCRIPTION	QTY.
A	2604	COVER	1
B	1069	CIRCUIT BREAKER 20A	1
C	1018	8/32 x 1/2 PHILLIPS SCREW	2
D	2605	STATOR BOLT	4
E	2606	GROUND SCREW	1
F	2607	BEARING BRACKET	1
G	2608	STATOR A25, A26, A30 - 60Hz	1
H	2609	COVER FOR STATOR	1
J	-	WASHER	4
K	-	NUT	4
M	2610	FAN BRACKET	1
N	-	SCREW & WASHER	4
P	2783	PTO BRACKET	1
Q	2783	BALL BEARING	1
R	2783	SHAFT EXTENSION	1
S	2612	FAN	1
T	2613	ROTOR SCREW	1
U	2614	ROTOR	1
V	2603	DIODE WITH SUPPRESSOR	2
W	2615	BALL BEARING	1
X	2616	CAPACITOR 10 MF	1
Y	2617	TY RAP	1
Z	2619	5/16 SQUARE NUT	1
AA	1011	DUPLEX RECEPTACLE 125V, 20A	1

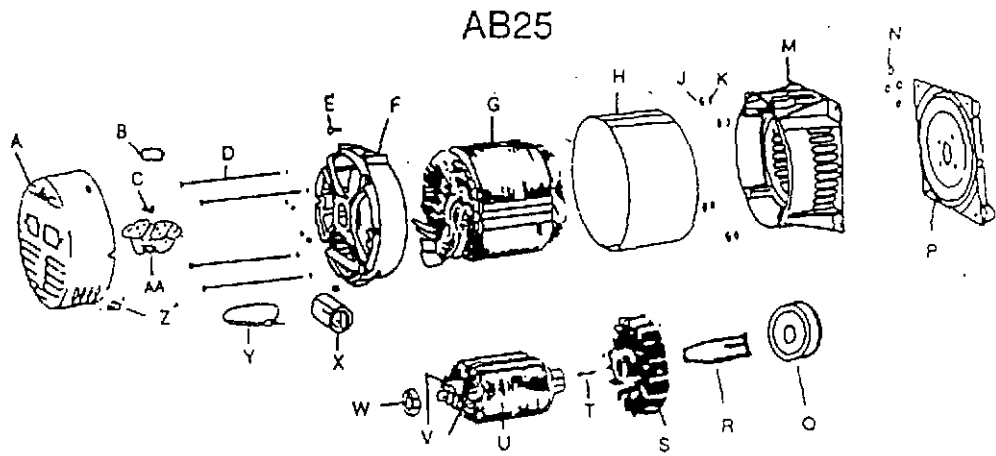

AB25

AB50 AND AB60

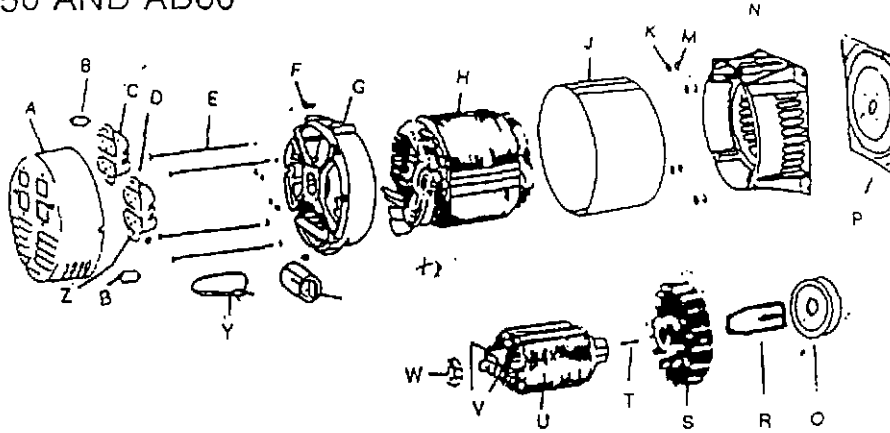

AB50 AND AB60 PARTS LIST

REF. NO.	PART NO.	DESCRIPTION	QTY. A50	QTY. A60
A	2621	COVER	1	1
B	1069	CIRCUIT BREAKER 20A	2	2
C	1011	DUPLEX RECEPTACLE 125V, 20A	1	1
D	1012	DUPLEX RECEPTACLE 250V, 15A	1	-
E	2688	DUPLEX RECEPTACLE 250V, 20A	-	1
F	2622	STATOR BOLT A50	4	-
G	2623	STATOR BOLT A60	-	4
H	2606	GROUND SCREW	1	1
I	2607	BEARING BRACKET	1	1
J	2624	STATOR A50 - 60Hz	1	-
K	2625	STATOR A60 - 60Hz	-	1
L	2630	STATOR A50 - 50Hz	1	-
M	2631	STATOR A60 - 50Hz	-	1
N	2626	COVER FOR STATOR A50	1	1
O	2627	COVER FOR STATOR A60	-	1
P	-	WASHER	4	4
Q	-	NUT	4	4
R	2610	FAN BRACKET	1	1
S	2784	PTO BRACKET	1	1
T	2784	BALL BEARING	1	1
U	2784	SHAFT EXTENSION	1	1
V	2612	FAN	1	1
W	2613	ROTOR SCREW	1	1
X	2628	ROTOR A50	1	-
Y	2628	ROTOR A60	-	1
Z	2603	DIODE WITH SUPPRESSOR	2	2
AA	2615	BALL BEARING	1	1
AB	2145	CAPACITOR 20 MF	1	-
AC	1134	CAPACITOR 31.5 MF	-	1
AD	2617	TY RAP	1	1
AE	1018	8/32 x 1/2 PHILLIPS	4	4

AE 100 PARTS LIST

REF. NO.	PART NO.	DESCRIPTION	QTY.
A	3185	TOP COVER	1
B	3186	CAPACITORS 92mf	-
C	3187	FAN GUARD	1
D	3188	FAN BRACKET	1
E	3182	BEARING 70MM	1
F	3189	FAN	1
G	3191	ROTOR	1
H	3190	DIODE W/SUPP.	2
J	2615	BEARING 52MM	1
K	2024	VOLTMETER	1
M	1112	CIR. BRKR 30A	2
N	1101	T LOCK REC 240V	1
P	1117	T LOCK REC 120V	1
Q	1011	DUP REC 120V	2
R	1069	CIR. BRKR 20A	2
S	2882	CIR. BRKR 40A	2
T	2231	SCREW 8/32 X 1/2	18
U	3167	FRONT COVER	1
V	3181	SCREW	4
W	3186	CONTROL BOX	1
X	3183	STATOR & HOUSING	1
Y	3184	TERMINAL STRIP	1
Z	1024	GROUND LUG	1

AE 100

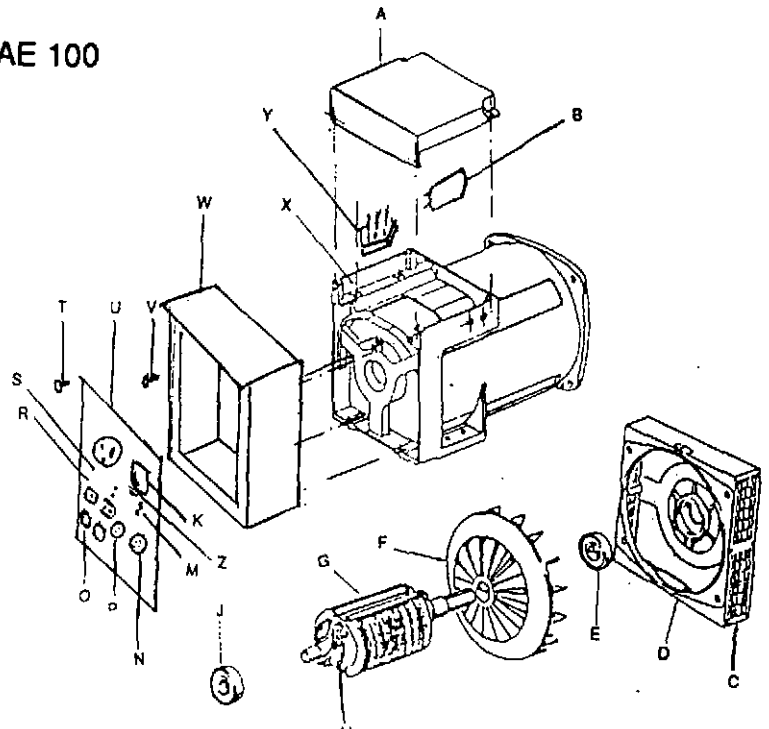



INSTRUCTIONS FOR REWIRING A 120/240 VOLT GENERATOR TO 120 VOLTS ONLY.

1. Remove 4 screws holding the end cover.
2. Disconnect the 120V duplex and the 240V duplex receptacles.
3. Connect the stator lead wires T1 and T3 together (hot lead) to circuit breaker. Tabs on circuit breaker must be bent 90° so they will not touch bearing bracket. You must use FULLY insulated 1/4" female slide connector.
4. Connect stator lead wires T2 and T4 together (neutral).
5. Connect green wire to ground connections on 120 volt, with slide connector to ground lug on aluminum bearing bracket.

6. Connect T1 and T3 via circuit breaker to one line side of 120 volt receptacle. Connect T2 and T4 to neutral side of 120 volt receptacle. The 120 volt duplex receptacle provided on the standard generator has a tab broken between the two outlets. Connect these two tabs together with a #12 wire as indicated on wiring diagram.
 7. **IMPORTANT:** Carefully push all wires to top, away from rotor nut in the center. The rotor nut will cut any loose wires. Reconnect end cover to the bearing bracket.
 8. **IMPORTANT:** You cannot have a 240 volt receptacle connected in this wiring configuration. The extra circuit breaker is not needed in this configuration.
 9. **IMPORTANT:** Before applying a load, check receptacle with a volt meter to verify proper voltage, 120 volts.
- NOTE:** Under no load conditions the voltage will be approximately 125 volts. Failure to check receptacle with a volt meter may result in damage to other equipment and or the generator.

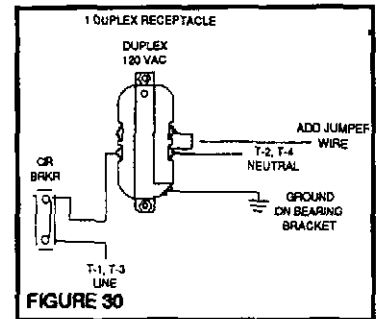

FIGURE 30

10. THE RECONNECTION INFORMATION (STEPS 1 THROUGH 9) IS NOT A DO IT YOURSELF PROJECT. THIS INFORMATION IS PROVIDED FOR LICENSED ELECTRICIANS OR AUTHORIZED SERVICE CENTERS ONLY.

PLUGS (NEMA Configuration)

RECEPTACLE ON GENERATOR	A25	A30	LA80 A80	LA80 A80	LV70	LV80	LV106	M80, M80 LM80, LM80	LV106E	LV100	AB25	AB30/40	AB100
120V Duplex (20A) (5-20P)	5-15P or 5-20P	5-15P or 5-20P	5-15P or 5-20P	5-15P or 5-20P	5-20P	5-15P or 5-20P	5-15P or 5-20P	5-15P or 5-20P	5-15P or 5-20P	5-15P or 5-20P	5-20P	5-20P	5-20P
240V Duplex (16A) (6-15R)		6-15P										6-15P	
240V Duplex (20A) (6-20R)				6-20P							6-20P		
120V Twistlock (20A) (L5-30P)			L5-30P	L5-30P	L5-30P	L5-30P	L5-30P	L5-30P	L5-30P	5-15P	L14-30P		L5-30P
120/240V Twistlock (20A) (L14-30P)			L14-30P	L14-30P				L14-30P			L14-30P		
120/240V Twistlock (30A) (L14-30P)					L14-30P	L14-30P	L14-30P	L14-30P	L14-30P	L14-30P			L14-30P
120V (16A) GFI (6-15R)								5-15P	5-15P	5-15P			
120V (80A) (5-80R)										5-80P			
240V (80A) (5-80R)										5-80P			

* OPTIONAL WITH FULL POWER CONTROL BOX

PLUGS (NEMA Configuration)

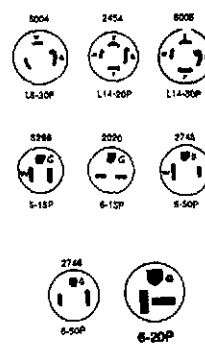

SCHEMATIC DIAGRAMS A25, A26, A30, V825 and Connection to Straight 120 Volt

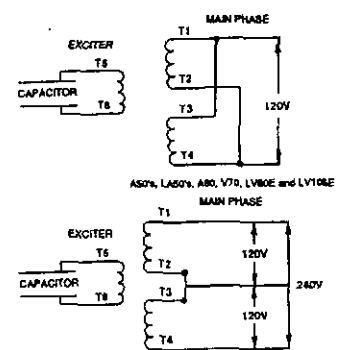

GENERAL INFORMATION

Instructions For Ordering Repair Parts

For parts or service, contact either the factory or the dealer or distributor from whom you purchased this equipment for the name of the Nearest Authorized Service Station.

1. To avoid errors or delay in filling your parts order, please furnish all information requested and always refer to the nameplate on your unit by giving the model and serial number.
2. Do not order by reference number or group number; always use part number and description.
3. Give the part number, description and quantity needed for each item.
4. State definite shipping instructions. Any claim for loss or damage to your unit in transit should be filed promptly against the transportation company making the delivery. Shipments are complete unless the packing list indicates items are back ordered.

Prices are purposely omitted from this Parts Catalog due to the confusion resulting from fluctuating costs, import duties, sales taxes, exchange rates, etc.

This product is equipped with an engine that is not covered by the warranty. The engine is covered by the manufacturer warranty. Your nearest engine service center is listed in the Yellow Pages under "Engines-Gasoline" or "Gasoline Engines".

ONE YEAR LIMITED WARRANTY - A, LA, V, LV, AND AB MODELS ONLY (NO IDLERS)

This warranty extends to the original purchaser only. The generator sold is warranted to the original purchaser for a period of one (1) year from the original purchase date. The manufacturer warrants the generator sold to be free from defects in material and workmanship if properly installed, serviced and operated within nameplate rating under normal conditions according to the manufacturer's instructions.

DISCLAIMERS

This warranty does not apply to any items which must be repaired or replaced due to normal wear, which have been subject to misuse, negligence, accident or which have been repaired, altered by others outside of the manufacturer's factory unless authorized in writing by the manufacturer.

The manufacturer makes no warranty with respect to the engine components not of its manufacture. They are subject to the warranties of their manufacturers.

Under no circumstances will the manufacturer be liable for any or consequential damage or expense of any kind, including loss of profits not for the fitness of the product for any specific application or particular purpose.

Any implied warranties are limited in duration to the above one (1) year period. Some states do not allow limitations on how long an implied warranty lasts, so the above limitation may not apply to you. Some states do not allow the exclusion or limitation of incidental or consequential damages, so the above limitation or exclusion may not apply to you. This warranty gives you specific legal rights, and you may also have other rights which vary from state to state.

PERFORMANCE

The manufacturer's obligation under this warranty is limited to correcting without further charge at its factory or authorized service station any part or parts which shall be returned transportation charges prepaid, and which upon examination shall disclose to the manufacturer's satisfaction to have been originally defective. Other than transportation charges, no charge will be made for such repair, adjustment and/or replacement. This remedy is expressly in lieu of all other remedies, and is the purchaser's sole and exclusive remedy hereunder.

TWO YEAR LIMITED WARRANTY - M, LM, LV1, LE MODELS ONLY (ALL WITH EASY IDLERS)

This warranty extends to the original purchaser only. The generator sold is warranted to the original purchaser for a period of two (2) year from the original purchase date. The manufacturer warrants the generator sold to be free from defects in material and workmanship if properly installed, serviced and operated within nameplate rating under normal conditions according to the manufacturer's instructions.

DISCLAIMERS

This warranty does not apply to any items which must be repaired or replaced due to normal wear, which have been subject to misuse, negligence, accident or which have been repaired, altered by others outside of the manufacturer's factory unless authorized in writing by the manufacturer.

The manufacturer makes no warranty with respect to the engine components not of its manufacture. They are subject to the warranties of their manufacturers.

Under no circumstances will the manufacturer be liable for any or consequential damage or expense of any kind, including loss of profits not for the fitness of the product for any specific application or particular purpose.

Any implied warranties are limited in duration to the above two (2) year period. Some states do not allow limitations on how long an implied warranty lasts, so the above limitation may not apply to you. Some states do not allow the exclusion or limitation of incidental or consequential damages, so the above limitation or exclusion may not apply to you. This warranty gives you specific legal rights, and you may also have other rights which vary from state to state.

PERFORMANCE

The manufacturer's obligation under this warranty is limited to correcting without further charge at its factory or authorized service station any part or parts which shall be returned transportation charges prepaid, and which upon examination shall disclose to the manufacturer's satisfaction to have been originally defective. Other than transportation charges, no charge will be made for such repair, adjustment and/or replacement. This remedy is expressly in lieu of all other remedies, and is the purchaser's sole and exclusive remedy hereunder.

NO WARRANTY REGISTRATION CARD IS NECESSARY TO OBTAIN WARRANTY. YOU MUST SAVE THE PURCHASE RECEIPT. A PROOF OF PURCHASE DATE WILL BE REQUIRED TO OBTAIN WARRANTY.