

Shark[®] 100 & 100T

LOW COST, HIGH PERFORMANCE MULTIFUNCTION ELECTRICITY METER

Installation & Operation Manual Revision 1.12

May 15, 2008
Doc #: E145701 V1.12



Electro Industries/GaugeTech

1800 Shames Drive
Westbury, New York 11590

Tel: 516-334-0870 ♦ Fax: 516-338-4741
Sales@electroind.com ♦ www.electroind.com

“The Leader in Web Accessed Power Monitoring and Control”

**Shark® 100 & 100T Meter
Installation and Operation Manual
Version 1.12**

Published by:
Electro Industries/GaugeTech
1800 Shames Drive
Westbury, NY 11590

All rights reserved. No part of this publication may be reproduced or transmitted in any form or by any means, electronic or mechanical, including photocopying, recording, or information storage or retrieval systems or any future forms of duplication, for any purpose other than the purchaser's use, without the expressed written permission of Electro Industries/GaugeTech.

© 2008

Shark® is a registered trademark of Electro Industries/Gauge Tech.

Printed in the United States of America.

Customer Service and Support

Customer support is available 9:00 am to 4:30 pm, eastern standard time, Monday through Friday. Please have the model, serial number and a detailed problem description available. If the problem concerns a particular reading, please have all meter readings available. When returning any merchandise to EIG, a return materials authorization number is required. For customer or technical assistance, repair or calibration, phone 516-334-0870 or fax 516-338-4741.

Product Warranty

Electro Industries/GaugeTech warrants all products to be free from defects in material and workmanship for a period of four years from the date of shipment. During the warranty period, we will, at our option, either repair or replace any product that proves to be defective.

To exercise this warranty, fax or call our customer-support department. You will receive prompt assistance and return instructions. Send the instrument, transportation prepaid, to EIG at 1800 Shames Drive, Westbury, NY 11590. Repairs will be made and the instrument will be returned.

Limitation of Warranty

This warranty does not apply to defects resulting from unauthorized modification, misuse, or use for any reason other than electrical power monitoring. The Shark® 100 Meter is not a user-serviceable product.

Our products are not to be used for primary over-current protection. Any protection feature in our products is to be used for alarm or secondary protection only.

THIS WARRANTY IS IN LIEU OF ALL OTHER WARRANTIES, EXPRESSED OR IMPLIED, INCLUDING ANY IMPLIED WARRANTY OF MERCHANTABILITY OR FITNESS FOR A PARTICULAR PURPOSE. ELECTRO INDUSTRIES/GAUGETECH SHALL NOT BE LIABLE FOR ANY INDIRECT, SPECIAL OR CONSEQUENTIAL DAMAGES ARISING FROM ANY AUTHORIZED OR UNAUTHORIZED USE OF ANY ELECTRO INDUSTRIES/GAUGETECH PRODUCT. LIABILITY SHALL BE LIMITED TO THE ORIGINAL COST OF THE PRODUCT SOLD.

Statement of Calibration

Our instruments are inspected and tested in accordance with specifications published by Electro Industries/GaugeTech. The accuracy and a calibration of our instruments are traceable to the National Institute of Standards and Technology through equipment that is calibrated at planned intervals by comparison to certified standards.

Disclaimer

The information presented in this publication has been carefully checked for reliability; however, no responsibility is assumed for inaccuracies. The information contained in this document is subject to change without notice.



This symbol indicates that the operator must refer to an explanation in the operating instructions. Please see Chapter 4, Electrical Installation, for important safety information regarding installation and hookup of the Shark® 100 Meter.

About Electro Industries/GaugeTech

Founded in 1973 by engineer and inventor Dr. Samuel Kagan, Electro Industries/GaugeTech changed the face of power monitoring forever with its first breakthrough innovation: an affordable, easy-to-use AC power meter.

Thirty years later, Electro Industries/GaugeTech, the leader in Web-Accessed Power Monitoring, continues to revolutionize the industry with the highest quality, cutting edge power monitoring and control technology on the market today. An ISO 9001:2000 certified company, EIG sets the industry standard for advanced power quality and reporting, revenue metering and substation data acquisition and control. The Nexus 1262/1272 transformer-rated, polyphase meter utilizing Accu-Measure© Digital Sensing Technology is an example of this standard. EIG products can be found on site at virtually all of today's leading manufacturers, industrial giants and utilities.

All EIG products are designed, manufactured, tested and calibrated at our facility in Westbury, New York.

Applications:

- Web-Accessed Multifunction Power Monitoring and Control
- Single and Multifunction Power Monitoring
- Power Quality Monitoring
- Onboard Data Logging for Trending Power Usage and Quality
- Disturbance Analysis

Table of Contents

EIG Warranty	ii
Chapter 1: Three-Phase Power Measurement	
1.1: Three-Phase System Configurations	1-1
1.1.1: Wye Connection	1-1
1.1.2: Delta Connection	1-3
1.1.3: Blondell's Theorem and Three Phase Measurement	1-4
1.2: Power, Energy and Demand	1-6
1.3: Reactive Energy and Power Factor	1-8
1.4: Harmonic Distortion	1-10
1.5: Power Quality	1-13
Chapter 2: Shark® Meter Overview and Specifications	
2.1: Hardware Overview	2-1
2.1.1: Voltage and Current Inputs	2-2
2.1.2: Model Number plus Option Numbers	2-2
2.1.3: V-Switch® Technology	2-3
2.1.4: Measured Values	2-3
2.1.5: Utility Peak Demand	2-4
2.2: Specifications	2-4
2.3: Compliance	2-6
2.4: Accuracy	2-6
Chapter 3: Mechanical Installation	
3.1: Introduction	3-1
3.2: ANSI Installation Steps	3-2
3.3: DIN Installation Steps	3-3
3.4: Shark® 100T Transducer Installation	3-4
Chapter 4: Electrical Installation	
4.1: Considerations When Installing Meters	4-1
4.2: CT Leads Terminated to Meter	4-2
4.3: CT Leads Pass Through (No Meter Termination)	4-3
4.4: Quick Connect Crimp CT Terminations	4-4
4.5: Voltage and Power Supply Connections	4-5
4.6: Ground Connections	4-5
4.7: Voltage Fuses	4-5
4.8: Electrical Connection Diagrams	4-6
Chapter 5: Communication Installation	
5.1: Shark® 100 Meter Communication	5-1
5.1.1: IrDA Port (Com 1)	5-1
5.1.2: RS-485 Communication Com 2 (485 Option)	5-2
5.1.3: RS-485 / KYZ Output Com 2 (485P Option)	5-3
5.1.3.1: Using the Unicom 2500	5-6
5.2: Shark® 100T Transducer Communication and Programming Overview	5-7

5.2.1: Factory Initial Default Settings	5-7
5.2.2: Shark® Meter Profile Settings	5-9

Chapter 6: Using the Meter

6.1: Introduction	6-1
6.1.1: Meter Face Elements	6-1
6.1.2: Meter Face Buttons	6-1
6.2: % of Load Bar	6-2
6.3: Watt-Hour Accuracy Testing (Verification)	6-3
6.3.1: Infrared & KYZ Pulse Constants for Accuracy Testing	6-3
6.4: Upgrade the Meter Using V-Switches	6-4

Chapter 7: Configuring the Shark® Meter Using the Front Panel

7.1: Overview	7-1
7.2: Start Up	7-1
7.3: Configuration	7-2
7.3.1: Main Menu	7-2
7.3.2: Reset Mode	7-2
7.3.2.1: Enter Password (ONLY IF ENABLED IN SOFTWARE)	7-3
7.3.3: Configuration Mode	7-4
7.3.3.1: Configure Scroll Feature	7-4
7.3.3.2: Program Configuration Mode Screens	7-5
7.3.3.3: Configure CT Setting	7-6
7.3.3.4: Configure PT Setting	7-7
7.3.3.5: Configure Connection (Cnct) Setting	7-8
7.3.3.6: Configure Communication Port Setting	7-9
7.3.4: Operating Mode	7-10

Appendix A: Shark® Meter Navigation Maps

A.1: Introduction	A-1
A.2: Navigation Maps (Sheets 1 to 4)	A-1
Main Menu Screens (Sheet 1)	
Operating Mode Screens (Sheet 2)	
Reset Mode Screens (Sheet 3)	
Configuration Mode Screens (Sheet 4)	

Appendix B: Modbus Mapping for Shark® Meter

B.1: Introduction	B-1
B.2: Modbus Register Map Sections	B-1
B.3: Data Formats	B-1
B.4: Floating Point Values	B-2
B.5: Modbus Register Map (MM-1 to MM-8)	B-2

Appendix C: DNP Mapping for Shark®100 Meter

C.1: Introduction C-1
C.2: DNP Mapping (DNP-1 to DNP-2) C-1

Appendix D: DNP Protocol Assignments for Shark® 100 Meter

D.1: Implementation D-1
D.2: Data Link Layer D-1
D.3: Transport Layer D-2
D.4: Application Layer D-2
D.4.1.1: Binary Output Status (Obj. 10, Var. 2) D-3
D.4.1.2: Control Relay Output (Obj. 12, Var. 1) D-4
D.4.1.3: 32-Bit Binary Counter Without Flag (Obj. 20, Var. 5) D-5
D.4.1.4: 16-Bit Analog Input Without Flag (Obj. 30, Var. 4) D-6
D.4.1.5: Class 0 Data (Obj. 60, Var. 1) D-10
D.4.1.6: Internal Indications (Obj. 80, Var. 1) D-10

Appendix E: Using the USB to IrDA Adapter

E.1: Introduction E-1
E.2: Installation Procedures E-1

Chapter 1

Three-Phase Power Measurement

This introduction to three-phase power and power measurement is intended to provide only a brief overview of the subject. The professional meter engineer or meter technician should refer to more advanced documents such as the *EEI Handbook for Electricity Metering* and the application standards for more in-depth and technical coverage of the subject.

1.1: Three-Phase System Configurations

Three-phase power is most commonly used in situations where large amounts of power will be used because it is a more effective way to transmit the power and because it provides a smoother delivery of power to the end load. There are two commonly used connections for three-phase power, a wye connection or a delta connection. Each connection has several different manifestations in actual use. When attempting to determine the type of connection in use, it is a good practice to follow the circuit back to the transformer that is serving the circuit. It is often not possible to conclusively determine the correct circuit connection simply by counting the wires in the service or checking voltages. Checking the transformer connection will provide conclusive evidence of the circuit connection and the relationships between the phase voltages and ground.

1.1.1: Wye Connection

- The wye connection is so called because when you look at the phase relationships and the winding relationships between the phases it looks like a wye (Y). Fig. 1.1 depicts the winding relationships for a wye-connected service. In a wye service the neutral (or center point of the wye) is typically grounded. This leads to common voltages of 208/120 and 480/277 (where the first number represents the phase-to-phase voltage and the second number represents the phase-to-ground voltage).

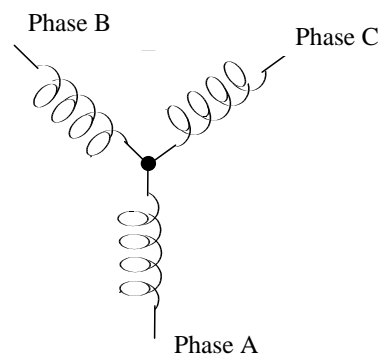

Figure 1.1: Three-Phase Wye Winding

- The three voltages are separated by 120° electrically. Under balanced load conditions with unity power factor the currents are also separated by 120° . However, unbalanced loads and other conditions can cause the currents to depart from the ideal 120° separation.

Three-phase voltages and currents are usually represented with a phasor diagram. A phasor diagram for the typical connected voltages and currents is shown in Figure 1.2.

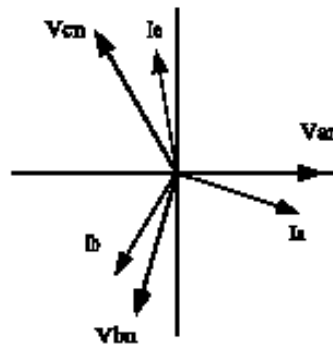

Fig 1.2: Phasor diagram showing Three-phase Voltages and Currents

- The phasor diagram shows the 120° angular separation between the phase voltages. The phase-to-phase voltage in a balanced three-phase wye system is 1.732 times the phase-to-neutral voltage. The center point of the wye is tied together and is typically grounded. Table 1.1 shows the common voltages used in the United States for wye-connected systems.

Phase-to-Ground Voltage	Phase-to-Phase Voltage
120 volts	208 volts
277 volts	480 volts
2,400 volts	4,160 volts
7,200 volts	12,470 volts
7,620 volts	13,200 volts

Table 1.1: Common Phase Voltages on Wye Services

- Usually a wye-connected service will have four wires; three wires for the phases and one for the neutral. The three-phase wires connect to the three phases (as shown in Fig. 1.1). The neutral wire is typically tied to the ground or center point of the wye (refer to Figure 1.1).

In many industrial applications the facility will be fed with a four-wire wye service but only three wires will be run to individual loads. The load is then often referred to as a delta-connected load but the service to the facility is still a wye service; it contains four wires if you trace the circuit back to its source (usually a transformer). In this type of connection the phase to ground voltage will be the phase-to-ground voltage indicated in Table 1.1, even though a neutral or ground wire is not physically present at the load. The transformer is the best place to determine the circuit connection type because this is a location where the voltage reference to ground can be conclusively identified.

1.1.2: Delta Connection

- Delta connected services may be fed with either three wires or four wires. In a three-phase delta service the load windings are connected from phase-to-phase rather than from phase-to-ground. Figure 1.3 shows the physical load connections for a delta service.

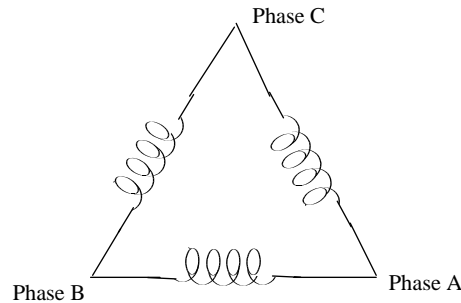

Figure 1.3: Three-Phase Delta Winding Relationship

In this example of a delta service, three wires will transmit the power to the load. In a true delta service, the phase-to-ground voltage will usually not be balanced because the ground is not at the center of the delta.

Fig. 1.4 shows the phasor relationships between voltage and current on a three-phase delta circuit.

In many delta services, one corner of the delta is grounded. This means the phase to ground voltage will be zero for one phase and will be full phase-to-phase voltage for the other two phases. This is done for protective purposes.

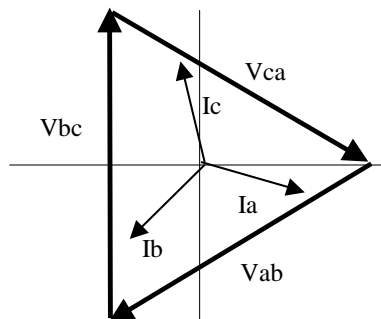

Figure 1.4: Phasor diagram showing three-phase voltages, currents delta connected.

- Another common delta connection is the four-wire, grounded delta used for lighting loads. In this connection the center point of one winding is grounded. On a 120/240 volt, four-wire, grounded delta service the phase-to-ground voltage would be 120 volts on two phases and 208 volts on the third phase. Figure 1.5 shows the phasor diagram for the voltages in a three-phase, four-wire delta system.

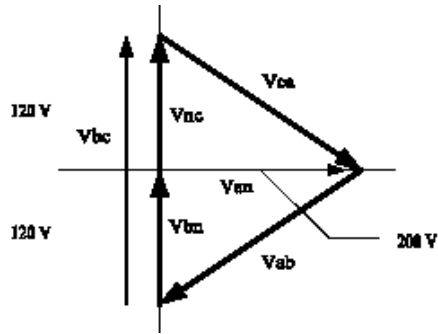

Fig 1.5: Phasor diagram showing Three-phase, Four-wire Delta Connected System

1.1.3: Blondell's Theorem and Three Phase Measurement

In 1893 an engineer and mathematician named Andre E. Blondell set forth the first scientific basis for poly phase metering. His theorem states:

- If energy is supplied to any system of conductors through N wires, the total power in the system is given by the algebraic sum of the readings of N wattmeters so arranged that each of the N wires contains one current coil, the corresponding potential coil being connected between that wire and some common point. If this common point is on one of the N wires, the measurement may be made by the use of N-1 wattmeters.

The theorem may be stated more simply, in modern language:

- In a system of N conductors, N-1 meter elements will measure the power or energy taken provided that all the potential coils have a common tie to the conductor in which there is no current coil.
- Three-phase power measurement is accomplished by measuring the three individual phases and adding them together to obtain the total three phase value. In older analog meters, this measurement was accomplished using up to three separate elements. Each element combined the single-phase voltage and current to produce a torque on the meter disk. All three elements were arranged around the disk so that the disk was subjected to the combined torque of the three elements. As a result the disk would turn at a higher speed and register power supplied by each of the three wires.
- According to Blondell's Theorem, it was possible to reduce the number of elements under certain conditions. For example, a three-phase, three-wire delta system could be correctly measured with two elements (two potential coils and two current coils) if the potential coils were connected between the three phases with one phase in common.

In a three-phase, four-wire wye system it is necessary to use three elements. Three voltage coils are connected between the three phases and the common neutral conductor. A current coil is required in each of the three phases.

- In modern digital meters, Blondell's Theorem is still applied to obtain proper metering. The difference in modern meters is that the digital meter measures each phase voltage and current and calculates the single-phase power for each phase. The meter then sums the three phase powers to a

single three-phase reading.

Some digital meters calculate the individual phase power values one phase at a time. This means the meter samples the voltage and current on one phase and calculates a power value. Then it samples the second phase and calculates the power for the second phase. Finally, it samples the third phase and calculates that phase power. After sampling all three phases, the meter combines the three readings to create the equivalent three-phase power value. Using mathematical averaging techniques, this method can derive a quite accurate measurement of three-phase power.

More advanced meters actually sample all three phases of voltage and current simultaneously and calculate the individual phase and three-phase power values. The advantage of simultaneous sampling is the reduction of error introduced due to the difference in time when the samples were taken.

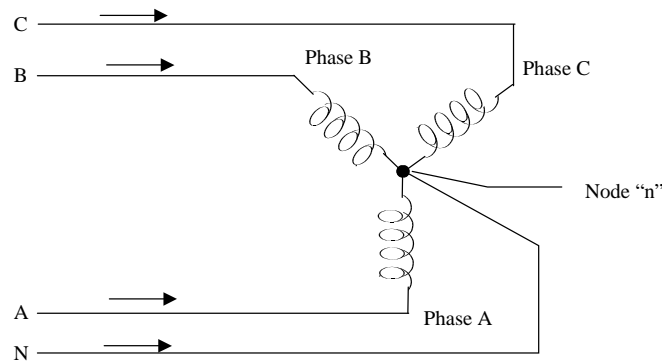

Figure 1.6: Three-Phase Wye Load illustrating Kirchhoff's Law and Blondell's Theorem

Blondell's Theorem is a derivation that results from Kirchhoff's Law. Kirchhoff's Law states that the sum of the currents into a node is zero. Another way of stating the same thing is that the current into a node (connection point) must equal the current out of the node. The law can be applied to measuring three-phase loads. Figure 1.6 shows a typical connection of a three-phase load applied to a three-phase, four-wire service. Kirchhoff's Laws hold that the sum of currents A, B, C and N must equal zero or that the sum of currents into Node "n" must equal zero.

If we measure the currents in wires A, B and C, we then know the current in wire N by Kirchhoff's Law and it is not necessary to measure it. This fact leads us to the conclusion of Blondell's Theorem that we only need to measure the power in three of the four wires if they are connected by a common node. In the circuit of Figure 1.6 we must measure the power flow in three wires. This will require three voltage coils and three current coils (a three element meter). Similar figures and conclusions could be reached for other circuit configurations involving delta-connected loads.

1.2: Power, Energy and Demand

- It is quite common to exchange power, energy and demand without differentiating between the three. Because this practice can lead to confusion, the differences between these three measurements will be discussed.
- Power is an instantaneous reading. The power reading provided by a meter is the present flow of watts. Power is measured immediately just like current. In many digital meters, the power value is actually measured and calculated over a one second interval because it takes some amount of time to calculate the RMS values of voltage and current. But this time interval is kept small to preserve the instantaneous nature of power.
- Energy is always based on some time increment; it is the integration of power over a defined time increment. Energy is an important value because almost all electric bills are based, in part, on the amount of energy used.
- Typically, electrical energy is measured in units of kilowatt-hours (kWh). A kilowatt-hour represents a constant load of one thousand watts (one kilowatt) for one hour. Stated another way, if the power delivered (instantaneous watts) is measured as 1,000 watts and the load was served for a one hour time interval then the load would have absorbed one kilowatt-hour of energy. A different load may have a constant power requirement of 4,000 watts. If the load were served for one hour it would absorb four kWh. If the load were served for 15 minutes it would absorb $\frac{1}{4}$ of that total or one kWh.
- Figure 1.7 shows a graph of power and the resulting energy that would be transmitted as a result of the illustrated power values. For this illustration, it is assumed that the power level is held constant for each minute when a measurement is taken. Each bar in the graph will represent the power load for the one-minute increment of time. In real life the power value moves almost constantly.
- The data from Figure 1.7 is reproduced in Table 2 to illustrate the calculation of energy. Since the time increment of the measurement is one minute and since we specified that the load is constant over that minute, we can convert the power reading to an equivalent consumed energy reading by multiplying the power reading times $\frac{1}{60}$ (converting the time base from minutes to hours).

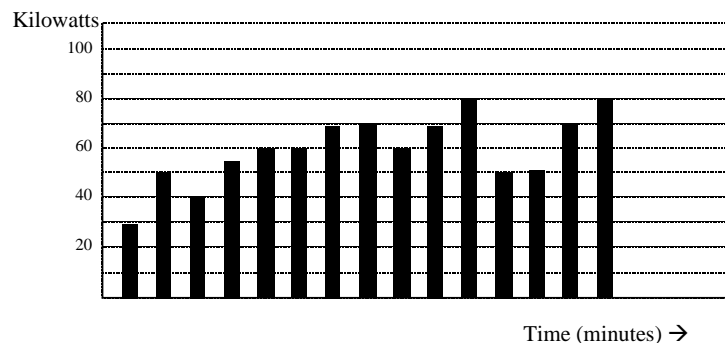

Figure 1.7: Power use over time

Time Interval (Minute)	Power (kW)	Energy (kWh)	Accumulated Energy (kWh)
1	30	0.50	0.50
2	50	0.83	1.33
3	40	0.67	2.00
4	55	0.92	2.92
5	60	1.00	3.92
6	60	1.00	4.92
7	70	1.17	6.09
8	70	1.17	7.26
9	60	1.00	8.26
10	70	1.17	9.43
11	80	1.33	10.76
12	50	0.83	12.42
13	50	0.83	12.42
14	70	1.17	13.59
15	80	1.33	14.92

Table 1.2: Power and energy relationship over time

As in Table 1.2, the accumulated energy for the power load profile of Figure 1.7 is 14.92 kWh.

- Demand is also a time-based value. The demand is the average rate of energy use over time. The actual label for demand is kilowatt-hours/hour but this is normally reduced to kilowatts. This makes it easy to confuse demand with power. But demand is not an instantaneous value. To calculate demand it is necessary to accumulate the energy readings (as illustrated in Figure 1.7) and adjust the energy reading to an hourly value that constitutes the demand.

In the example, the accumulated energy is 14.92 kWh. But this measurement was made over a 15-minute interval. To convert the reading to a demand value, it must be normalized to a 60-minute interval. If the pattern were repeated for an additional three 15-minute intervals the total energy would be four times the measured value or 59.68 kWh. The same process is applied to calculate the 15-minute demand value. The demand value associated with the example load is 59.68 kWh/hr or 59.68 kWd. Note that the peak instantaneous value of power is 80 kW, significantly more than the demand value.

- Figure 1.8 shows another example of energy and demand. In this case, each bar represents the energy consumed in a 15-minute interval. The energy use in each interval typically falls between 50 and 70 kWh. However, during two intervals the energy rises sharply and peaks at 100 kWh in interval number 7. This peak of usage will result in setting a high demand reading. For each interval shown the demand value would be four times the indicated energy reading. So interval 1 would have an associated demand of 240 kWh/hr. Interval 7 will have a demand value of 400 kWh/hr. In the data shown, this is the peak demand value and would be the number that would set the demand charge on the utility bill.

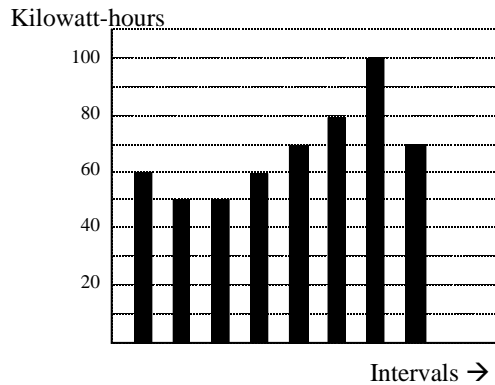

Figure 1.8: Energy use and demand

- As can be seen from this example, it is important to recognize the relationships between power, energy and demand in order to control loads effectively or to monitor use correctly.

1.3: Reactive Energy and Power Factor

- The real power and energy measurements discussed in the previous section relate to the quantities that are most used in electrical systems. But it is often not sufficient to only measure real power and energy. Reactive power is a critical component of the total power picture because almost all real-life applications have an impact on reactive power. Reactive power and power factor concepts relate to both load and generation applications. However, this discussion will be limited to analysis of reactive power and power factor as they relate to loads. To simplify the discussion, generation will not be considered.
- Real power (and energy) is the component of power that is the combination of the voltage and the value of corresponding current that is directly in phase with the voltage. However, in actual practice the total current is almost never in phase with the voltage. Since the current is not in phase with the voltage, it is necessary to consider both the inphase component and the component that is at quadrature (angularly rotated 90° or perpendicular) to the voltage. Figure 1.9 shows a single-phase voltage and current and breaks the current into its in-phase and quadrature components.

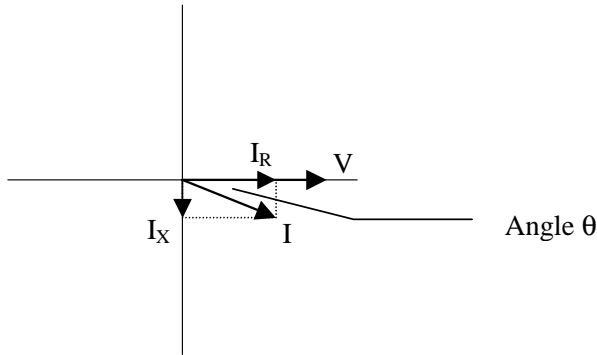

Figure 1.9: Voltage and complex current

- The voltage (V) and the total current (I) can be combined to calculate the apparent power or VA. The voltage and the in-phase current (I_R) are combined to produce the real power or watts. The voltage and the quadrature current (I_X) are combined to calculate the reactive power.

The quadrature current may be lagging the voltage (as shown in Figure 1.9) or it may lead the voltage. When the quadrature current lags the voltage the load is requiring both real power (watts) and reactive power (VARs). When the quadrature current leads the voltage the load is requiring real power (watts) but is delivering reactive power (VARs) back into the system; that is VARs are flowing in the opposite direction of the real power flow.

- Reactive power (VARs) is required in all power systems. Any equipment that uses magnetization to operate requires VARs. Usually the magnitude of VARs is relatively low compared to the real power quantities. Utilities have an interest in maintaining VAR requirements at the customer to a low value in order to maximize the return on plant invested to deliver energy. When lines are carrying VARs, they cannot carry as many watts. So keeping the VAR content low allows a line to carry its full capacity of watts. In order to encourage customers to keep VAR requirements low, most utilities impose a penalty if the VAR content of the load rises above a specified value.

A common method of measuring reactive power requirements is power factor. Power factor can be defined in two different ways. The more common method of calculating power factor is the ratio of the real power to the apparent power. This relationship is expressed in the following formula:

$$\text{Total PF} = \text{real power} / \text{apparent power} = \text{watts/VA}$$

This formula calculates a power factor quantity known as Total Power Factor. It is called Total PF because it is based on the ratios of the power delivered. The delivered power quantities will include the impacts of any existing harmonic content. If the voltage or current includes high levels of harmonic distortion the power values will be affected. By calculating power factor from the power values, the power factor will include the impact of harmonic distortion. In many cases this is the preferred method of calculation because the entire impact of the actual voltage and current are included.

A second type of power factor is Displacement Power Factor. Displacement PF is based on the angular relationship between the voltage and current. Displacement power factor does not consider the magnitudes of voltage, current or power. It is solely based on the phase angle differences. As a

result, it does not include the impact of harmonic distortion. Displacement power factor is calculated using the following equation:

Displacement PF = $\cos \theta$, where θ is the angle between the voltage and the current (see Fig. 1.9).

In applications where the voltage and current are not distorted, the Total Power Factor will equal the Displacement Power Factor. But if harmonic distortion is present, the two power factors will not be equal.

1.4: Harmonic Distortion

- Harmonic distortion is primarily the result of high concentrations of non-linear loads. Devices such as computer power supplies, variable speed drives and fluorescent light ballasts make current demands that do not match the sinusoidal waveform of AC electricity. As a result, the current waveform feeding these loads is periodic but not sinusoidal. Figure 1.10 shows a normal, sinusoidal current waveform. This example has no distortion.

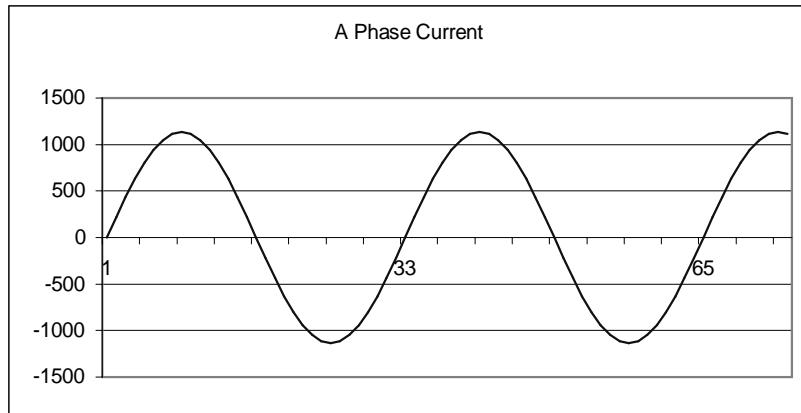

Figure 1.10: Non-distorted current waveform

- Figure 1.11 shows a current waveform with a slight amount of harmonic distortion. The waveform is still periodic and is fluctuating at the normal 60 Hz frequency. However, the waveform is not a smooth sinusoidal form as seen in Figure 1.10.

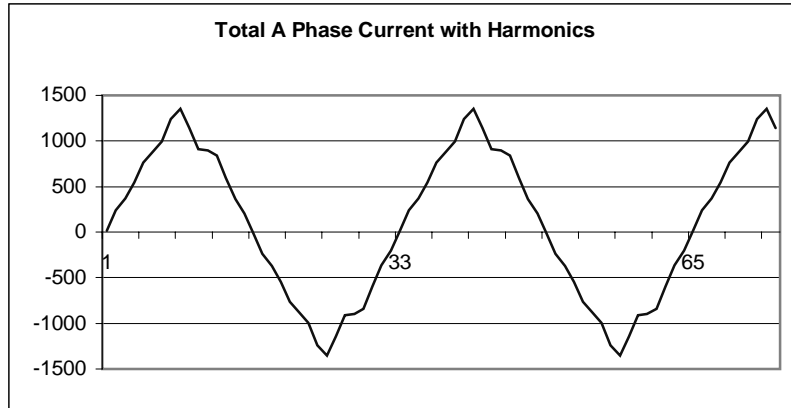

Figure 1.11: Distorted current wave

- The distortion observed in Figure 1.11 can be modeled as the sum of several sinusoidal waveforms of frequencies that are multiples of the fundamental 60 Hz frequency. This modeling is performed by mathematically disassembling the distorted waveform into a collection of higher frequency waveforms. These higher frequency waveforms are referred to as harmonics. Figure 1.12 shows the content of the harmonic frequencies that make up the distortion portion of the waveform in Figure 1.11.

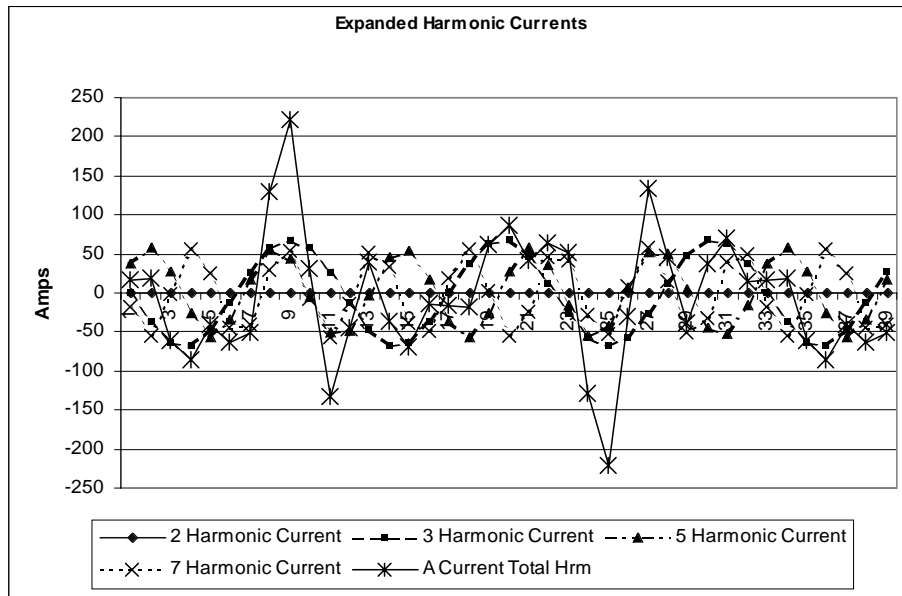

Figure 1.12: Waveforms of the harmonics

The waveforms shown in Figure 1.12 are not smoothed but do provide an indication of the impact of combining multiple harmonic frequencies together.

When harmonics are present it is important to remember that these quantities are operating at higher frequencies. Therefore, they do not always respond in the same manner as 60 Hz values.

- Inductive and capacitive impedance are present in all power systems. We are accustomed to thinking about these impedances as they perform at 60 Hz. However, these impedances are subject to frequency variation.

$$X_L = j\omega L \quad \text{and}$$

$$X_C = 1/j\omega C$$

At 60 Hz, $\omega = 377$; but at 300 Hz (5th harmonic) $\omega = 1,885$. As frequency changes impedance changes and system impedance characteristics that are normal at 60 Hz may behave entirely different in presence of higher order harmonic waveforms.

Traditionally, the most common harmonics have been the low order, odd frequencies, such as the 3rd, 5th, 7th, and 9th. However newer, non-linear loads are introducing significant quantities of higher order harmonics.

- Since much voltage monitoring and almost all current monitoring is performed using instrument transformers, the higher order harmonics are often not visible. Instrument transformers are designed to pass 60 Hz quantities with high accuracy. These devices, when designed for accuracy at low frequency, do not pass high frequencies with high accuracy; at frequencies above about 1200 Hz they pass almost no information. So when instrument transformers are used, they effectively filter out higher frequency harmonic distortion making it impossible to see.
- However, when monitors can be connected directly to the measured circuit (such as direct connection to 480 volt bus) the user may often see higher order harmonic distortion. An important rule in any harmonics study is to evaluate the type of equipment and connections before drawing a conclusion. Not being able to see harmonic distortion is not the same as not having harmonic distortion.
- It is common in advanced meters to perform a function commonly referred to as waveform capture. Waveform capture is the ability of a meter to capture a present picture of the voltage or current waveform for viewing and harmonic analysis. Typically a waveform capture will be one or two cycles in duration and can be viewed as the actual waveform, as a spectral view of the harmonic content, or a tabular view showing the magnitude and phase shift of each harmonic value. Data collected with waveform capture is typically not saved to memory. Waveform capture is a real-time data collection event.

Waveform capture should not be confused with waveform recording that is used to record multiple cycles of all voltage and current waveforms in response to a transient condition.

1.5: Power Quality

- Power quality can mean several different things. The terms ‘power quality’ and ‘power quality problem’ have been applied to all types of conditions. A simple definition of ‘power quality problem’ is any voltage, current or frequency deviation that results in mis-operation or failure of customer equipment or systems. The causes of power quality problems vary widely and may originate in the customer equipment, in an adjacent customer facility or with the utility.

In his book “Power Quality Primer”, Barry Kennedy provided information on different types of power quality problems. Some of that information is summarized in Table 1.3 below.

Cause	Disturbance Type	Source
Impulse Transient	Transient voltage disturbance, sub-cycle duration	Lightning Electrostatic discharge Load switching Capacitor switching
Oscillatory transient with decay	Transient voltage, sub-cycle duration	Line/cable switching Capacitor switching Load switching
Sag / swell	RMS voltage, multiple cycle duration	Remote system faults
Interruptions	RMS voltage, multiple second or longer duration	System protection Circuit breakers Fuses Maintenance
Undervoltage / Overvoltage	RMS voltage, steady state, multiple second or longer duration	Motor starting Load variations Load dropping
Voltage flicker	RMS voltage, steady state, repetitive condition	Intermittent loads Motor starting Arc furnaces
Harmonic distortion	Steady state current or voltage, long term duration	Non-linear loads System resonance

Table 1.3: Typical power quality problems and sources

- It is often assumed that power quality problems originate with the utility. While it is true that many power quality problems can originate with the utility system, many problems originate with customer equipment. Customer-caused problems may manifest themselves inside the customer location or they may be transported by the utility system to another adjacent customer. Often, equipment that is sensitive to power quality problems may in fact also be the cause of the problem.
- If a power quality problem is suspected, it is generally wise to consult a power quality professional for assistance in defining the cause and possible solutions to the problem.

Chapter 2

Shark® Meter Overview and Specifications

2.1: Hardware Overview

- The Shark®100 is a multifunction power meter designed to be used in electrical substations, panel boards and as a power meter for OEM equipment. The unit provides multifunction measurement of all electrical parameters.

The unit is designed with advanced measurement capabilities, allowing it to achieve high performance accuracy. The Shark® is specified as a 0.2% class energy meter for billing applications as well as a highly accurate panel indication meter.

A Shark® meter provides a host of additional capabilities, including standard RS-485 Modbus and DNP Protocols and an IrDA Port remote interrogation.



Figure 2.1: Shark® 100 (Meter / Transducer)

- Shark® meter features that are detailed in this manual, include:
 - 0.2% Class Revenue Certifiable Energy and Demand Metering
 - Meets ANSI C12.20 (0.2%) and IEC 687 (0.2%) Classes
 - Multifunction Measurement including Voltage, Current, Power, Frequency, Energy, etc.
 - Power Quality Measurements (%THD and Alarm Limits)
 - **V-Switch® Technology** - Field Upgrade without Removing Installed Meter
 - Percentage of Load Bar for Analog Meter Perception
 - Easy to Use Faceplate Programming
 - **IrDA Port** for PDA Remote Read
 - RS-485 Modbus Communication
- **Shark® 100 Meter:** a Meter / Digital Transducer in one compact unit. It features an IrDA port as well as an RS-485 port and can be programmed using the faceplate of the meter. ANSI or DIN mounting may be used.
- **Shark® 100T Transducer:** a Digital Transducer only unit providing RS-485 communication via Modbus RTU, Modbus ASCII and DNP 3.0 (V3 and V4) protocols. The unit is designed to install using DIN Rail Mounting (see section 3.4).



Figure 2.2: Shark® 100T (Transducer Only)

2.1.1: Voltage and Current Inputs

■ Universal Voltage Inputs

Voltage Inputs allow measurement to 416 Volts Line-to-Neutral and 721 Volts Line-to-Line. This insures proper meter safety when wiring directly to high voltage systems. One unit will perform to specification on 69 Volt, 120 Volt, 230 Volt, 277 Volt, 277 Volt and 347 Volt power systems.

■ Current Inputs

The Shark® 100 meter's Current Inputs use a unique dual input method:

Method 1: CT Pass Through.

The CT passes directly through the meter without any physical termination on the meter. This insures that the meter cannot be a point of failure on the CT circuit. This is preferable for utility users when sharing relay class CTs. No Burden is added to the secondary CT circuit.

Method 2: Current “Gills”.

This unit additionally provides ultra-rugged Termination Pass Through Bars that allow CT leads to be terminated on the meter. This, too, eliminates any possible point of failure at the meter. This is a preferred technique for insuring that relay class CT integrity is not compromised (the CT will not open in a fault condition).

2.1.2: Model Number plus Option Numbers

Model	Frequency	Current Class	V-Switch Pack	Power Supply	COM (Shark 100 Only)	Mounting (Shark 100 Only)
Shark® 100 Meter/ Transducer	- 50 50 Hz System	- 10 5 Amp Secondary	- V1 Default V-Switch Volts/Amps	-D2 90-265V AC/DC	- X No Com	- X ANSI Mounting
Shark® 100T Transducer Only	- 60 60 Hz System	- 2 1 Amp Secondary	- V2 Above with Power and Freq	-D 24-48V DC	-485P RS485 + Pulse (Standard in Shark 100T)	-DIN DIN Mounting Brackets
			- V3 Above with DNP 3.0 and Energy Counters			
			- V4 Above with Harmonics and Limits			

Example:

Shark100 - 60 - 10 - V2 - D - X - X

2.1.3: V-Switch® Technology

The Shark® 100 meter is equipped with EIG's exclusive V-Switch® Technology. V-Switch® is a virtual firmware-based switch that allows you to enable meter features through communication, allowing the unit to be upgraded after installation to a higher model without removing the unit from service.

■ **Available V-Switches®**

V-Switch 1 (-V1): Volts and Amps Meter - Default

V-Switch 2 (-V2): Volts, Amps, kW, kVAR, PF, kVA, Freq

V-Switch 3 (-V3): Volts, Amps, kW, kVAR, PF, kVA, Freq., kWh, kVAh, kVARh & DNP 3.0

V-Switch 4 (-V4): Volts, Amps, kW, kVAR, PF, kVA, Freq., kWh, kVAh, kVARh, %THD Monitoring, Limit Exceeded Alarms and DNP 3.0

2.1.4: Measured Values

The Shark® 100 meter provides the following Measured Values all in Real Time and some additionally as Avg, Max and Min values.

Shark® 100 Meter Measured Values				
Measured Values	Real Time	Avg	Max	Min
Voltage L-N	X		X	X
Voltage L-L	X		X	X
Current Per Phase	X	X	X	X
Current Neutral	X			
Watts	X	X	X	X
VAR	X	X	X	X
VA	X	X	X	X
PF	X	X	X	X
+Watt-Hr	X			
- Watt-Hr	X			
Watt-Hr Net	X			
+VAR-Hr	X			
-VAR-Hr	X			
VAR-Hr Net	X			
VA-Hr	X			
Frequency	X		X	X
%THD	X		X	X
Voltage Angles	X			
Current Angles	X			
% of Load Bar	X			

2.1.5: Utility Peak Demand

The Shark® 100 meter provides user-configured Block (Fixed) Window or Rolling Window Demand. This feature allows you to set up a Customized Demand Profile. Block Window Demand is demand used over a user-configured demand period (usually 5, 15 or 30 minutes). Rolling Window Demand is a fixed window demand that moves for a user-specified subinterval period. For example, a 15-minute Demand using 3 subintervals and providing a new demand reading every 5 minutes, based on the last 15 minutes.

Utility Demand Features can be used to calculate kW, kVAR, kVA and PF readings. All other parameters offer Max and Min capability over the user-selectable averaging period. Voltage provides an Instantaneous Max and Min reading which displays the highest surge and lowest sag seen by the meter

2.2: Specifications

■ Power Supply

- Range: D2 Option: Universal, (90 to 265) VAC @50/60Hz or (100 to 370) VDC
D Option: (18-60) VDC
- Power Consumption: 5 VA, 3.5W

■ Voltage Inputs (Measurement Category III)

- Range: Universal, Auto-ranging up to 416Vac L-N, 721Vac L-L
- Supported hookups: 3 Element Wye, 2.5 Element Wye, 2 Element Delta, 4 Wire Delta
- Input Impedance: 1M Ohm/Phase
- Burden: 0.0144VA/Phase at 120 Volts
- Pickup Voltage: 10Vac
- Connection: Screw terminal (Diagram 4.4)
- Max Input Wire Gauge: AWG#12 / 2.5mm²
- Fault Withstand: Meets IEEE C37.90.1
- Reading: Programmable Full Scale to any PT Ratio

■ Current Inputs

- Class 10: 5A Nominal, 10A Maximum
- Class 2: 1A Nominal, 2A Maximum
- Burden: 0.005VA Per Phase Max at 11 Amps
- Pickup Current: 0.1% of Nominal

- Connections: O or U Lug Electrical Connection (Diagram 4.1)
Pass-through Wire, 0.177" / 4.5mm Maximum Diameter (Diagram 4.2)
Quick Connect, 0.25" Male Tab (Diagram 4.3)

- Fault Withstand: 100A/10sec., 300A/3sec., 500A/1sec.
- Reading: Programmable Full Scale to any CT Ratio

■ Isolation

- All Inputs and Outputs are galvanically isolated to 2500 Vac

■ Environmental Rating

- Storage: (-40 to +85)⁰ C
- Operating: (-30 to +70)⁰ C
- Humidity: to 95% RH Non-condensing
- Faceplate Rating: NEMA12 (Water Resistant), Mounting Gasket Included

■ Measurement Methods

- Voltage, Current: True RMS
- Power: Sampling at 400+ Samples per Cycle on All Channels Measured
Readings Simultaneously
- A/D Conversion: 6 Simultaneous 24 bit Analog to Digital Converters

■ Update Rate

- Watts, VAR and VA: 100 milliseconds (Ten times per second)
- All other parameters: 1 second

■ Communication Format

1. RS-485 Port through Back Plate
2. IrDA Port through Face Plate
3. RS-485P - RS-485 and KYZ Pulse

- Protocols: Modbus RTU, Modbus ASCII, DNP 3.0 (V3 and V4
V-Switches)
- Com Port Baud Rate: 9600 to 57,600 b/s
- Com Port Address: 001-247
- Data Format: 8 Bit, No Parity
- Shark 100T Default Initial Communication Baud 9600 (see Chapter 5)

■ Mechanical Parameters

- Dimensions: (H4.85 x W4.82 x L4.25) inches, (H123.2 x W123.2 x
L105.4) mm
Mounts in 92mm square DIN or ANSI C39.1, 4" Round Cut-out
- Weight: 2 pounds, 0.907kg (ships in a 6"/152.4mm cube container)

2.3: Compliance

- IEC 687 (0.2% Accuracy)
- ANSI C12.20 (0.2% Accuracy)
- ANSI (IEEE) C37.90.1 Surge Withstand
- ANSI C62.41 (Burst)
- IEC1000-4-2: ESD
- IEC1000-4-3: Radiated Immunity
- IEC1000-4-4: Fast Transient
- IEC1000-4-5: Surge Immunity

2.4: Accuracy

Meter Accuracy by Measured Parameters		
Measured Parameters	Accuracy % of Reading*	Display Range
Voltage L-N	0.1%	0-9999 V or kV Autoscale
Voltage L-L	0.1%	0-9999 V or kV Autoscale
Current Phase	0.1%	0-9999 A or kA Autoscale
Current Neutral (Calculated)	2.0% F.S.	0-9999 A or kA Autoscale
+/- Watts	0.2%	0-9999 Watts, kWatts, MWatts
+/- Wh	0.2%	5 to 8 Digits Programmable
+/- VARs	0.2%	0-9999 VARs, kVARs, MVARs
+/- VARh	0.2%	5 to 8 Digits Programmable
VA	0.2%	0-9999 VA, kVA, MVA
VAh	0.2%	5 to 8 Digits Programmable
PF	0.2%	+/- 0.5 to 1.0
Frequency	+/- 0.01 Hz	45 to 65 Hz
% THD	2.0% F.S.	0 to 100%
% Load Bar	1 - 120%	10 Segment Resolution Scalable
* Accuracy stated for 5 amp secondary WYE or Delta connections. For 1 amp secondary or 2.5 element connections, add 0.1% of Full Scale + 1 digit to accuracy specification.		

Chapter 3 Mechanical Installation

3.1: Introduction

- The Shark 100 meter can be installed using a standard ANSI C39.1 (4" Round) or an IEC 92mm DIN (Square) form. In new installations, simply use existing DIN or ANSI punches. For existing panels, pull out old analog meters and replace with the Shark 100. The various models use the same installation. See section 3.4 for **Shark 100T Installation**. See Chapter 4 for wiring diagrams.

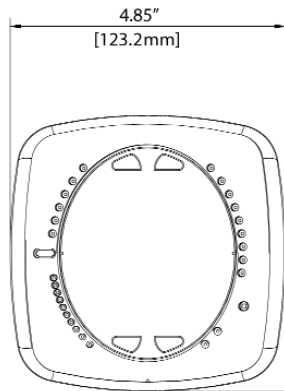

Figure 3.1: Shark 100 Face

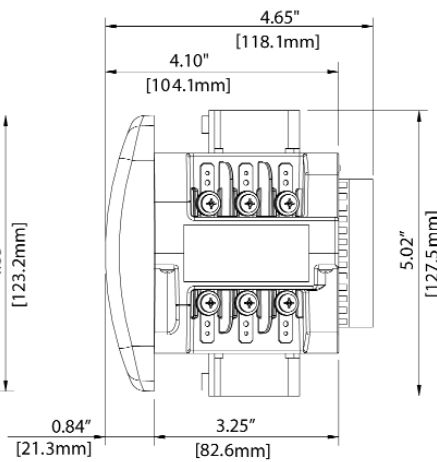

Figure 3.2: Shark 100 Dimensions

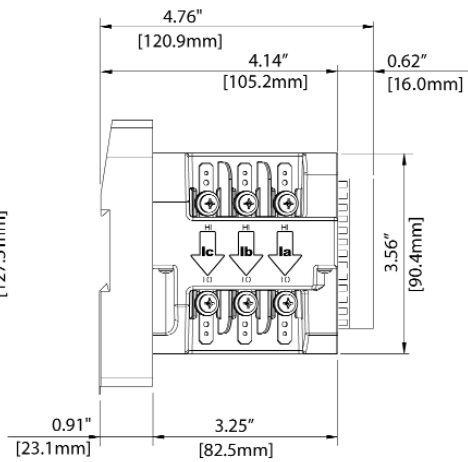

Figure 3.3: Shark 100T Dimensions

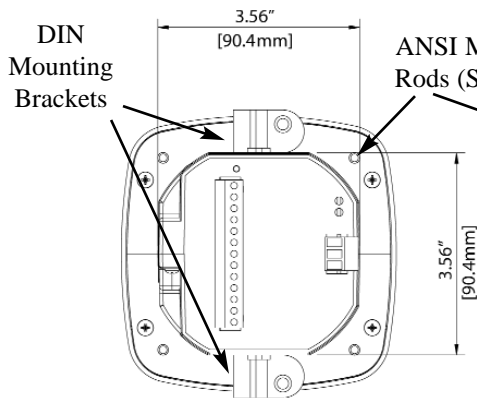

Fig. 3.4: Shark 100 Back Face

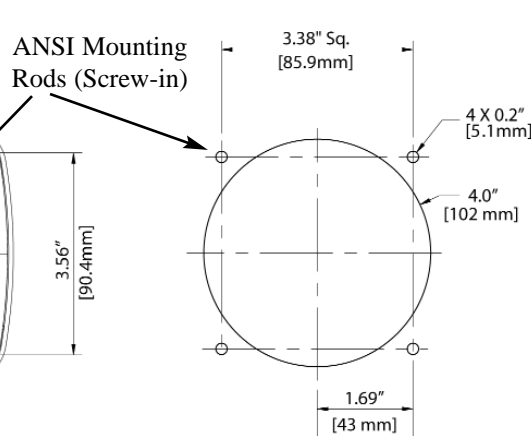

Figure 3.5: ANSI Mounting Panel Cutout

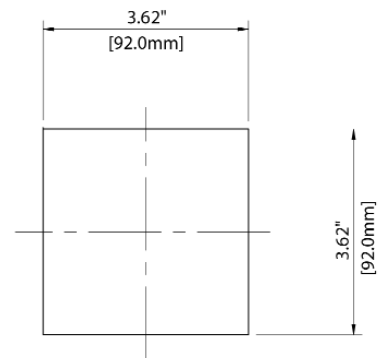

Figure 3.6: DIN Mounting Cutout

- **Recommended Tools for Shark 100 Installation:** #2 Phillips screwdriver, Small wrench and Wire cutters. Shark 100T Installation requires no tools.
- Mount the meter in a dry location, which is free from dirt and corrosive substances. The meter is designed to withstand harsh environmental conditions. (See Environmental Specifications in Chapter 2.)

3.2: ANSI Installation Steps

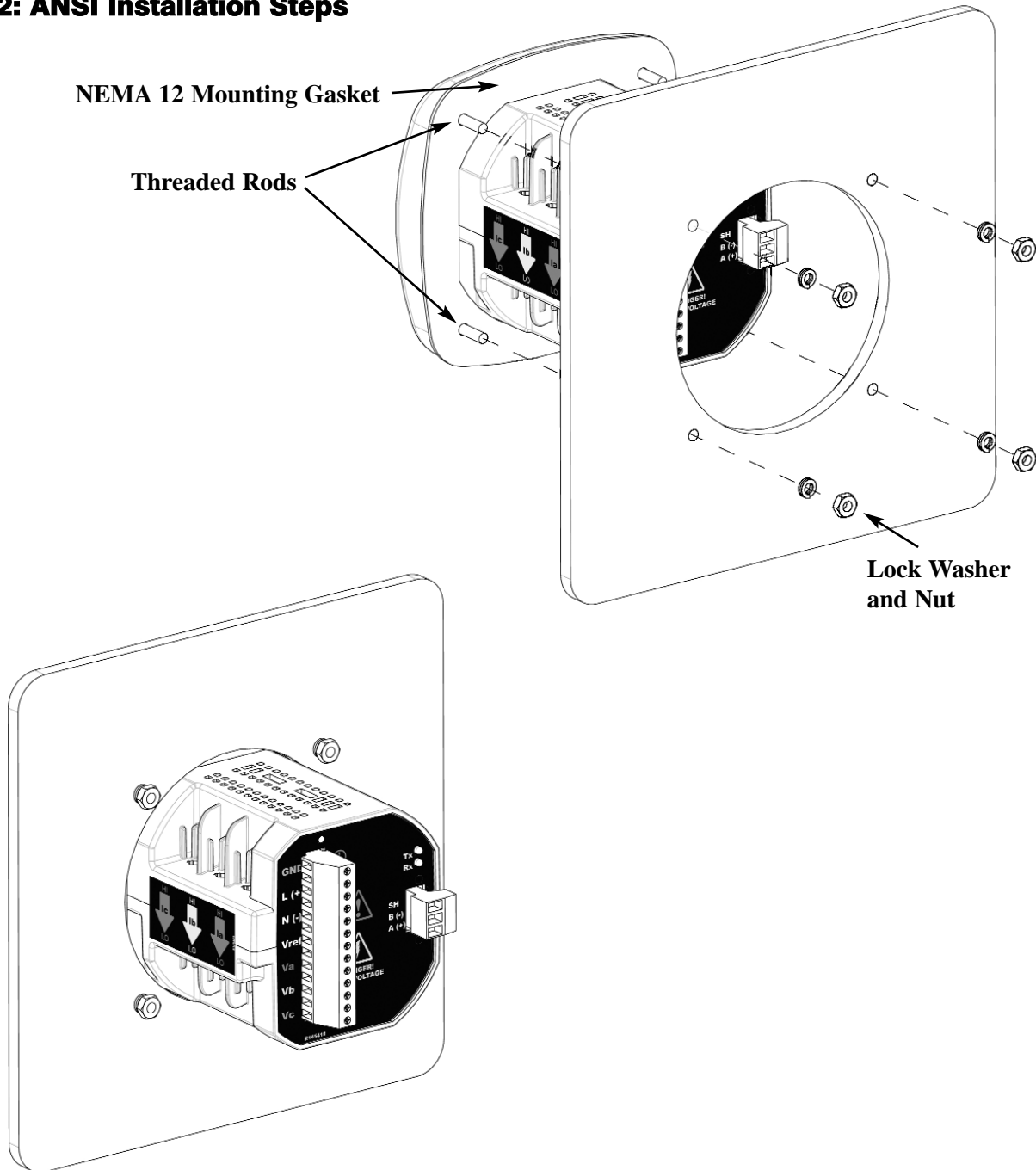

Figure 3.7: ANSI Mounting Procedure

ANSI INSTALLATION STEPS:

1. Insert 4 threaded rods by hand into the back of meter. Twist until secure.
2. Slide ANSI 12 Mounting Gasket onto back of meter with rods in place.
3. Slide meter with Mounting Gasket into panel.
4. Secure from back of panel with lock washer and nut on each threaded rod. Use a small wrench to tighten. Do not overtighten.

3.3: DIN Installation Steps

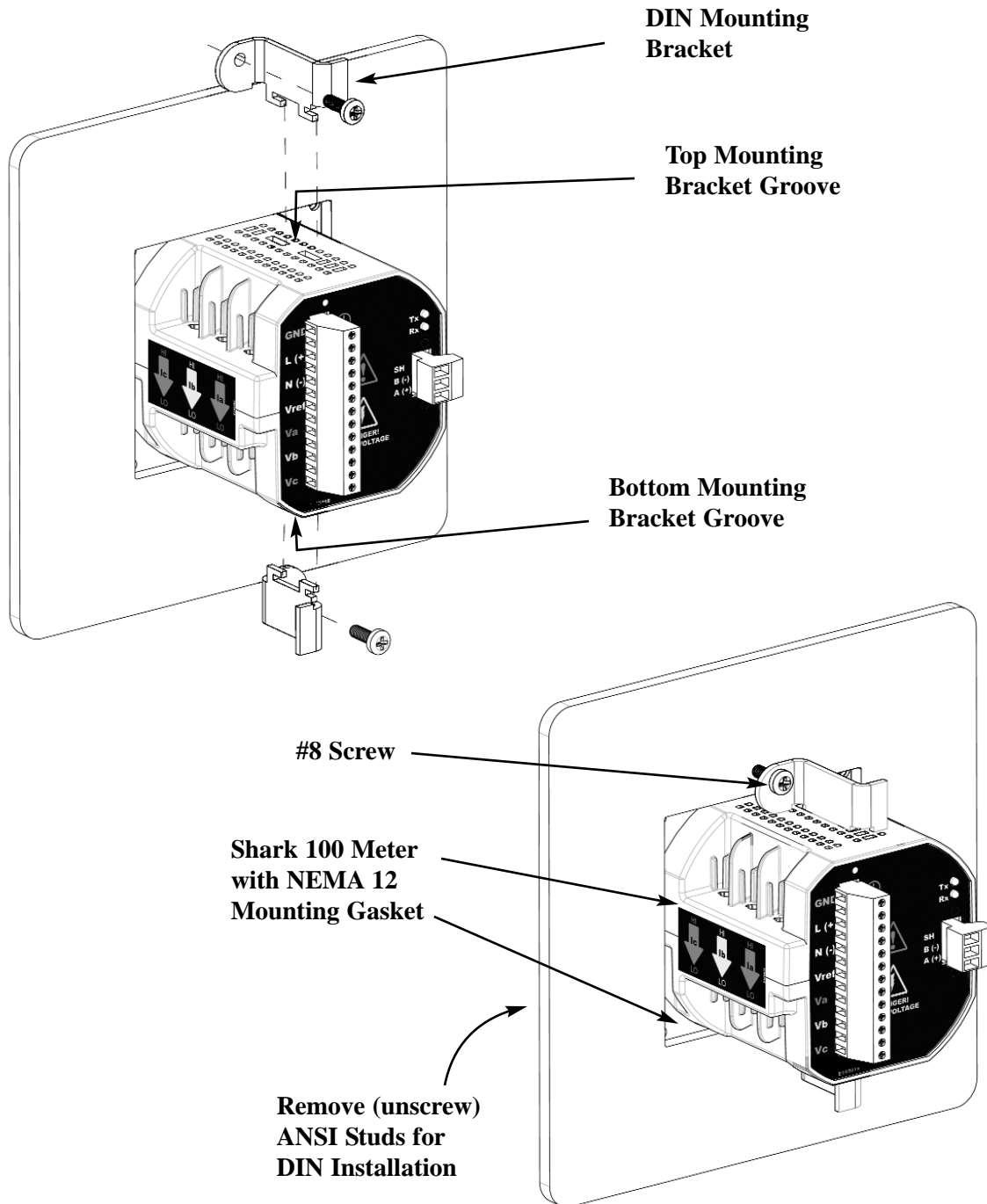

Figure 3.8: DIN Mounting Procedure

DIN INSTALLATION STEPS:

1. Slide meter with NEMA 12 Mounting Gasket into panel. (Remove ANSI Studs, if in place.)
2. From back of panel, slide 2 DIN Mounting Brackets into grooves in top and bottom of meter housing. Snap into place.
3. Secure meter to panel with lock washer and a #8 screw through each of the 2 mounting brackets. Tighten with a #2 Phillips screwdriver. Do not overtighten.

3.4: Shark 100T Transducer Installation

- The Shark 100T Transducer model is installed using DIN Rail Mounting.
- **Specs for DIN Rail Mounting:** International Standards DIN 46277/3
DIN Rail (Slotted) Dimensions: 0.297244" x 1.377953" x 3" (inches)
7.55mm x 35mm x 76.2mm (millimeters)

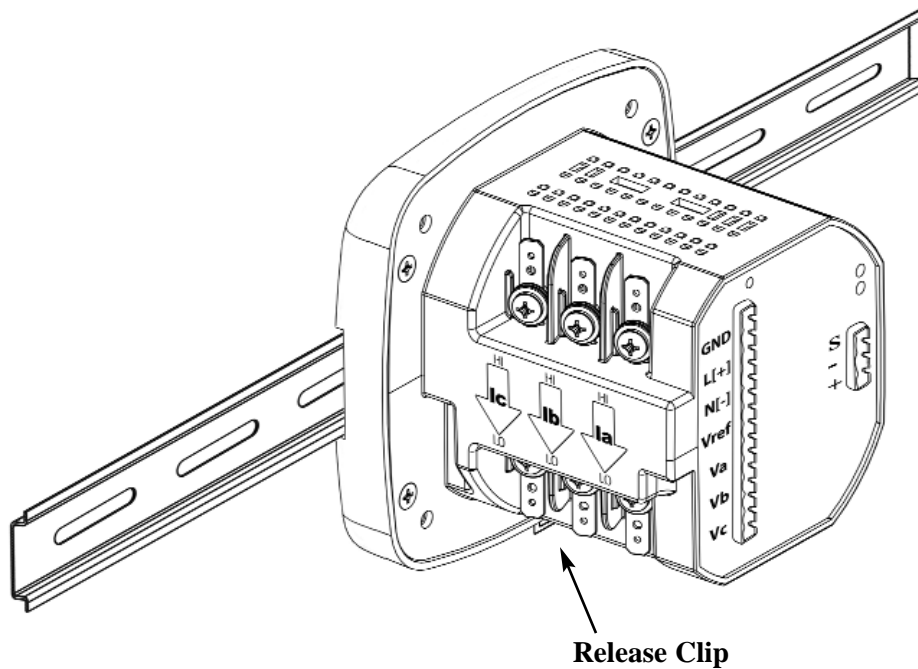

Figure 3.9: DIN Rail Mounting Procedure

DIN RAIL INSTALLATION STEPS:

1. Slide top groove of meter onto the DIN Rail.
2. Press gently until the meter clicks into place.

NOTE: If mounting with the **DIN Rail provided**, use the **Black Rubber Stoppers** (also provided).

TO REMOVE METER FROM DIN RAIL:

Pull down on **Release Clip** to detach the unit from the DIN Rail.

NOTE ON DIN RAILS:

DIN Rails are commonly used as a mounting channel for most terminal blocks, control devices, circuit protection devices and PLCs. DIN Rails are made of cold rolled steel electrolytically plated and are also available in aluminum, PVC, stainless steel and copper.

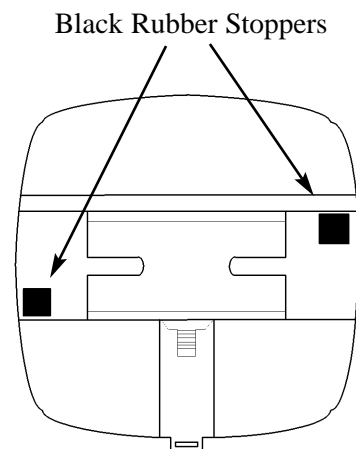

Figure 3.10: DIN Rail Detail

Chapter 4

Electrical Installation



4.1: Considerations When Installing Meters

- Installation of the Shark 100 Meter must be performed by only qualified personnel who follow standard safety precautions during all procedures. Those personnel should have appropriate training and experience with high voltage devices. Appropriate safety gloves, safety glasses and protective clothing is recommended.
- During normal operation of the Shark 100 Meter, dangerous voltages flow through many parts of the meter, including: Terminals and any connected CTs (Current Transformers) and PTs (Potential Transformers), all I/O Modules (Inputs and Outputs) and their circuits. All Primary and Secondary circuits can, at times, produce lethal voltages and currents. Avoid contact with any current-carrying surfaces.
- Do not use the meter or any I/O Output Device for primary protection or in an energy-limiting capacity. The meter can only be used as secondary protection. Do not use the meter for applications where failure of the meter may cause harm or death. Do not use the meter for any application where there may be a risk of fire.
- All meter terminals should be inaccessible after installation.
- Do not apply more than the maximum voltage the meter or any attached device can withstand. Refer to meter and/or device labels and to the Specifications for all devices before applying voltages. Do not HIPOT/Dielectric test any Outputs, Inputs or Communications terminals.
- EIG recommends the use of **Shorting Blocks** and **Fuses** for voltage leads and power supply to prevent hazardous voltage conditions or damage to CTs, if the meter needs to be removed from service. **CT grounding is optional.**



NOTE: IF THE EQUIPMENT IS USED IN A MANNER NOT SPECIFIED BY THE MANUFACTURER, THE PROTECTION PROVIDED BY THE EQUIPMENT MAY BE IMPAIRED.

NOTE: THERE IS NO REQUIRED PREVENTIVE MAINTENANCE OR INSPECTION NECESSARY FOR SAFETY. HOWEVER, ANY REPAIR OR MAINTENANCE SHOULD BE PERFORMED BY THE FACTORY.



DISCONNECT DEVICE: The following part is considered the equipment disconnect device.

A SWITCH OR CIRCUIT-BREAKER SHALL BE INCLUDED IN THE END-USE EQUIPMENT OR BUILDING INSTALLATION. THE SWITCH SHALL BE IN CLOSE PROXIMITY TO THE EQUIPMENT AND WITHIN EASY REACH OF THE OPERATOR. THE SWITCH SHALL BE MARKED AS THE DISCONNECTING DEVICE FOR THE EQUIPMENT.

4.2: CT Leads Terminated to Meter

- The Shark 100 is designed to have Current Inputs wired in one of three ways. Diagram 4.1 shows the most typical connection where CT Leads are terminated to the meter at the Current Gills. This connection uses Nickel-Plated Brass Studs (Current Gills) with screws at each end. This connection allows the CT wires to be terminated using either an “O” or a “U” lug. Tighten the screws with a #2 Phillips screwdriver.

Other current connections are shown in Figures 4.2 and 4.3. A Voltage and RS-485 Connection is shown in Figure 4.4.

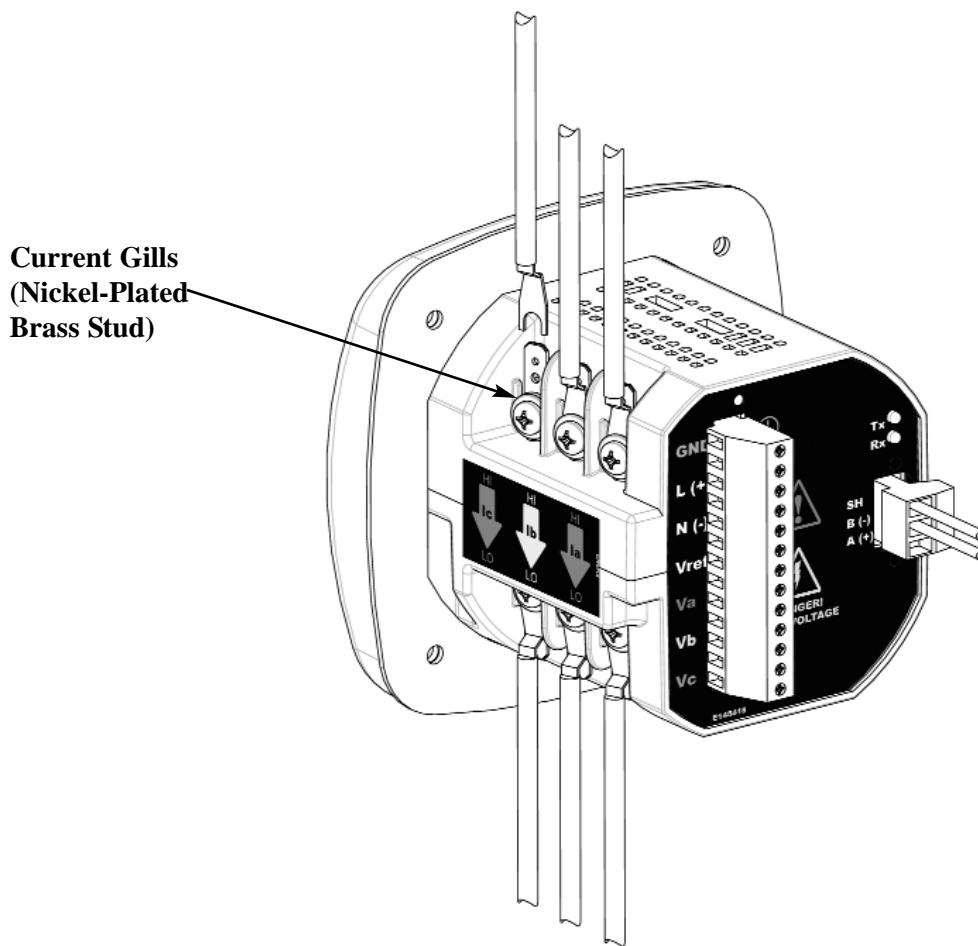

Figure 4.1: CT Leads terminated to Meter, #8 Screw for Lug Connection

Wiring Diagrams are shown in section 4.8 of this chapter.
Communications Connections are detailed in Chapter 5.

4.3: CT Leads Pass Through (No Meter Termination)

- The second method allows the CT wires to pass through the CT Inputs without terminating at the meter. In this case, remove the Current Gills and place the CT wire directly through the CT opening. The opening will accommodate up to 0.177" / 4.5mm maximum diameter CT wire.

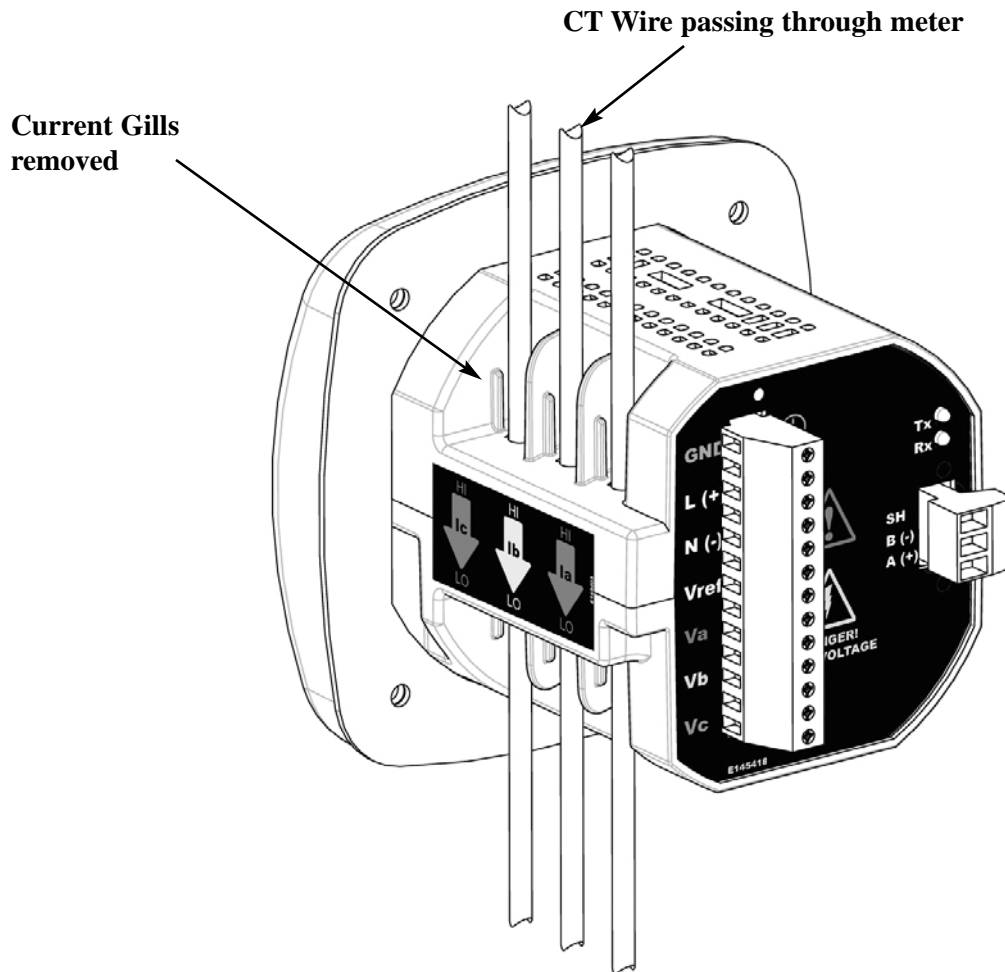

Figure 4.2: Pass-Through Wire Electrical Connection

4.4: Quick Connect Crimp CT Terminations

- For Quick Termination or for Portable Applications, a Quick Connect Crimp CT Connection can also be used.

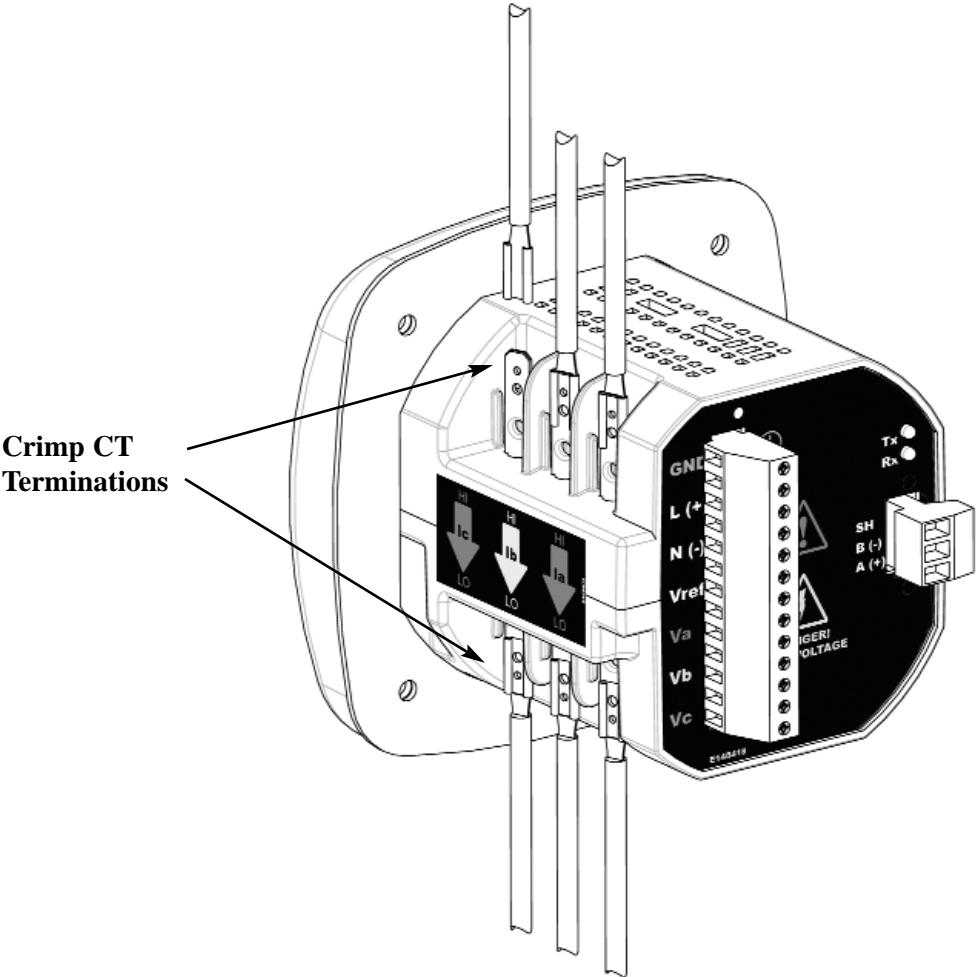

Figure 4.3: Quick Connect Electrical Connection

4.5: Voltage and Power Supply Connections

- Voltage Inputs are connected to the back of the unit via a optional wire connectors. The connectors accomodate up to AWG#12 / 2.5mm wire.

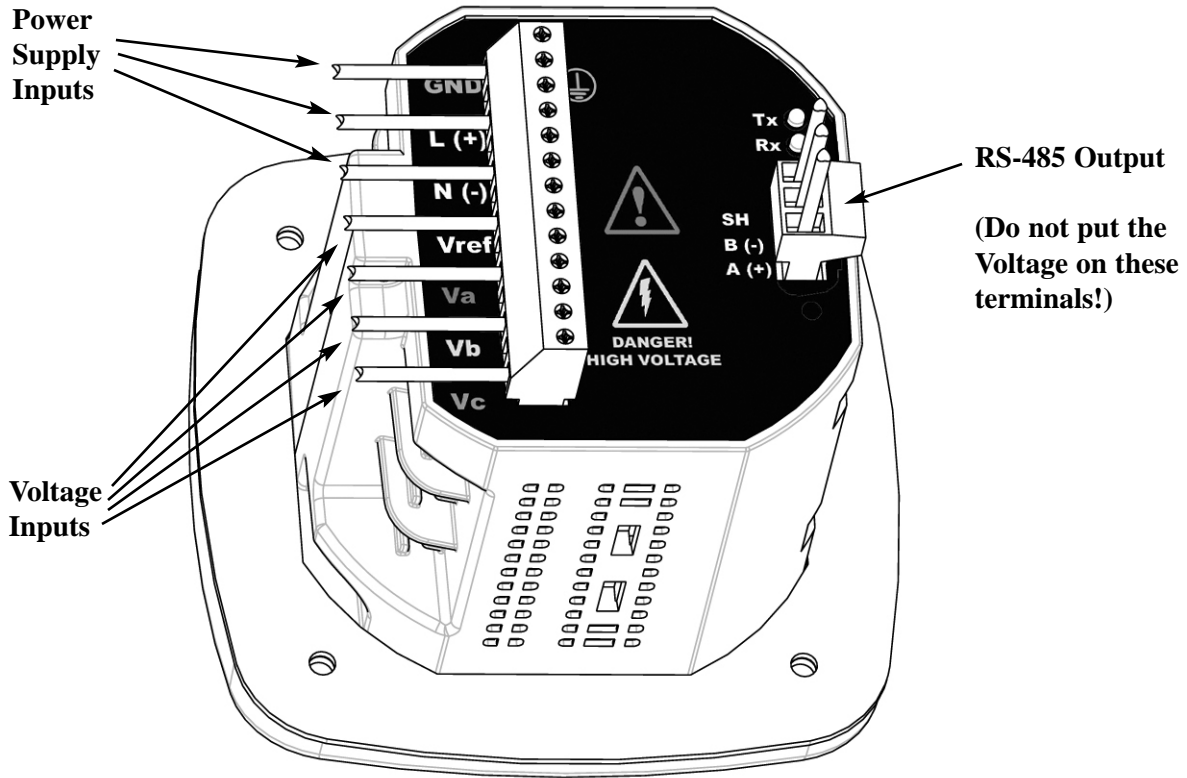

Figure 4.4: Voltage Connection

4.6: Ground Connections

- The meter's Ground Terminals (\perp) should be connected directly to the installation's protective earth ground. Use 2.5mm wire for this connection.

4.7: Voltage Fuses

- EIG recommends the use of **fuses** on each of the **sense voltages** and on the **control power**, even though the wiring diagrams in this chapter do not show them.

Use a **0.1 Amp fuse** on each voltage input.
Use a **3 Amp fuse** on the power supply.

4.8: Electrical Connection Diagrams

Choose the diagram that best suits your application. Be sure to maintain the CT polarity when wiring.

1. Three Phase, Four-Wire System Wye with Direct Voltage, 3 Element
2. Three Phase, Four-Wire System Wye with Direct Voltage, 2.5 Element
3. Three-Phase, Four-Wire Wye with PTs, 3 Element
4. Three-Phase, Four-Wire Wye with PTs, 2.5 Element
5. Three-Phase, Three-Wire Delta with Direct Voltage
6. Three-Phase, Three-Wire Delta with 2 PTs
7. Three-Phase, Three-Wire Delta with 3 PTs
8. Current Only Measurement (Three Phase)
9. Current Only Measurement (Dual Phase)
10. Current Only Measurement (Single Phase)

1. Service: WYE, 4-Wire with No PTs, 3 CTs

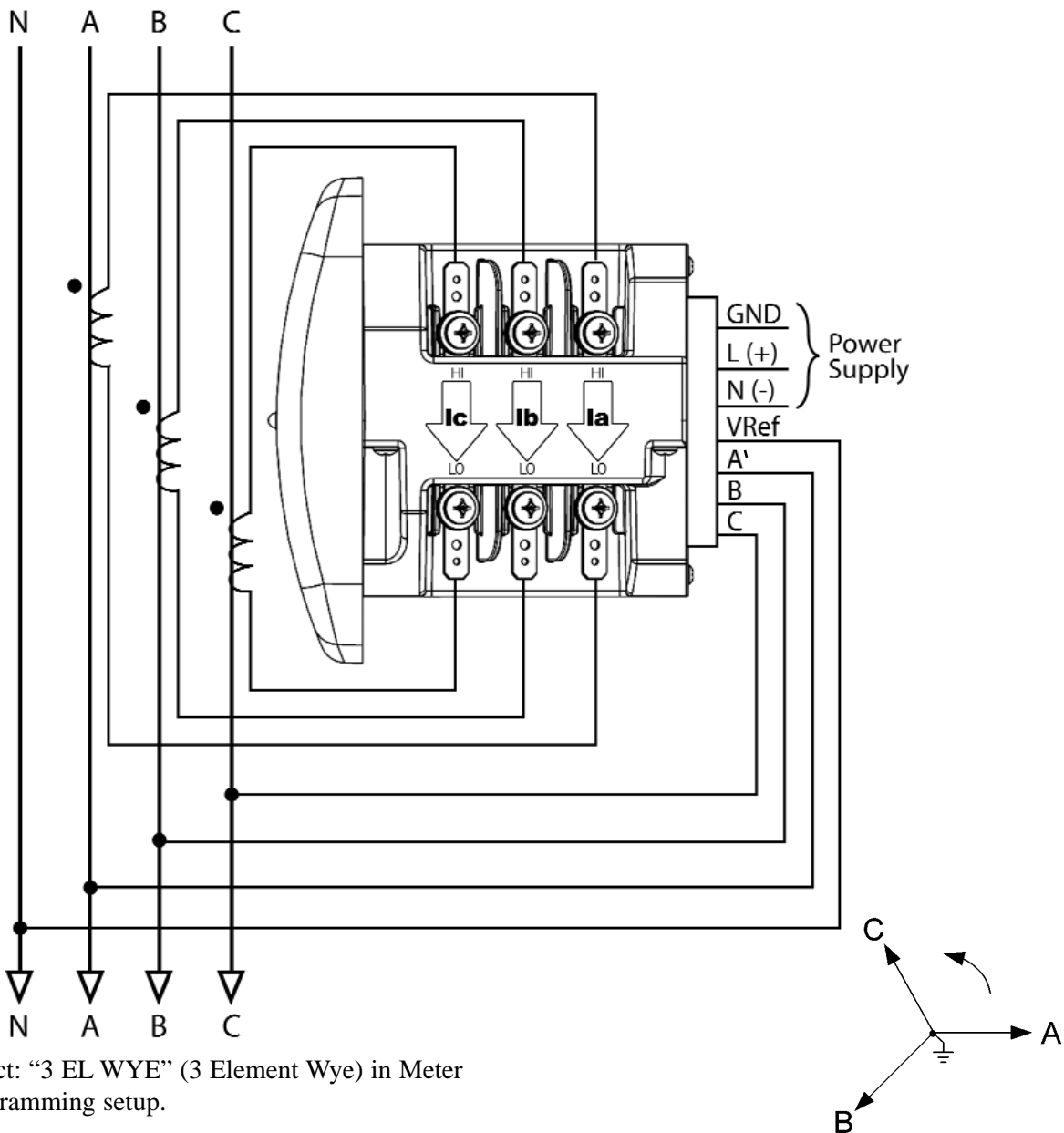

Select: "3 EL WYE" (3 Element Wye) in Meter Programming setup.

2. Service: 2.5 Element WYE, 4-Wire with No PTs, 3 CTs

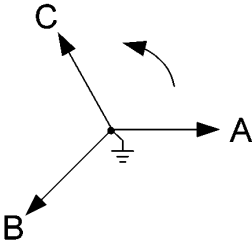
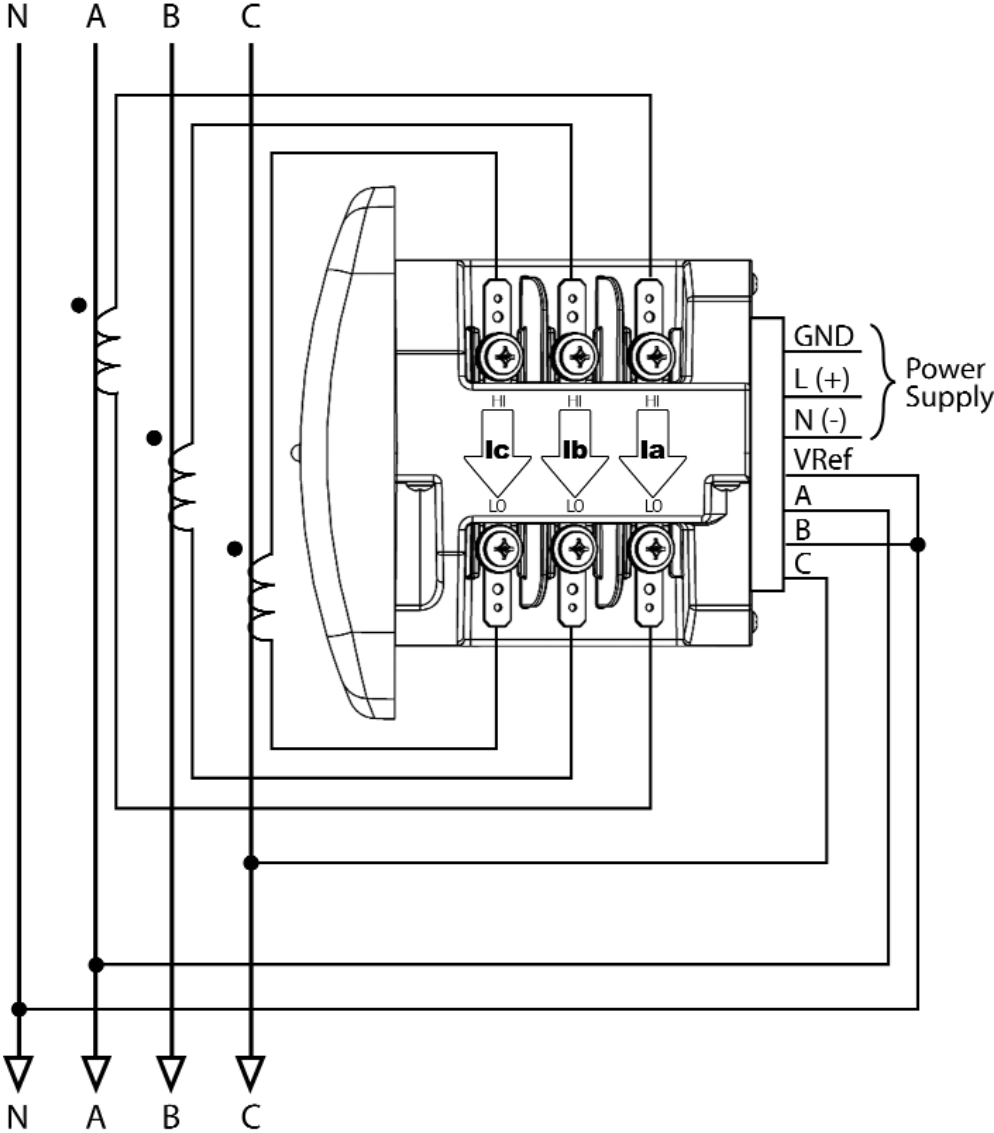

Select: "2.5 EL WYE" (2.5 Element Wye) in Meter Programming setup.

3. Service: WYE, 4-Wire with 3 PTs, 3 CTs

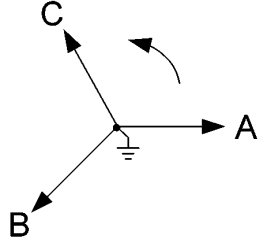
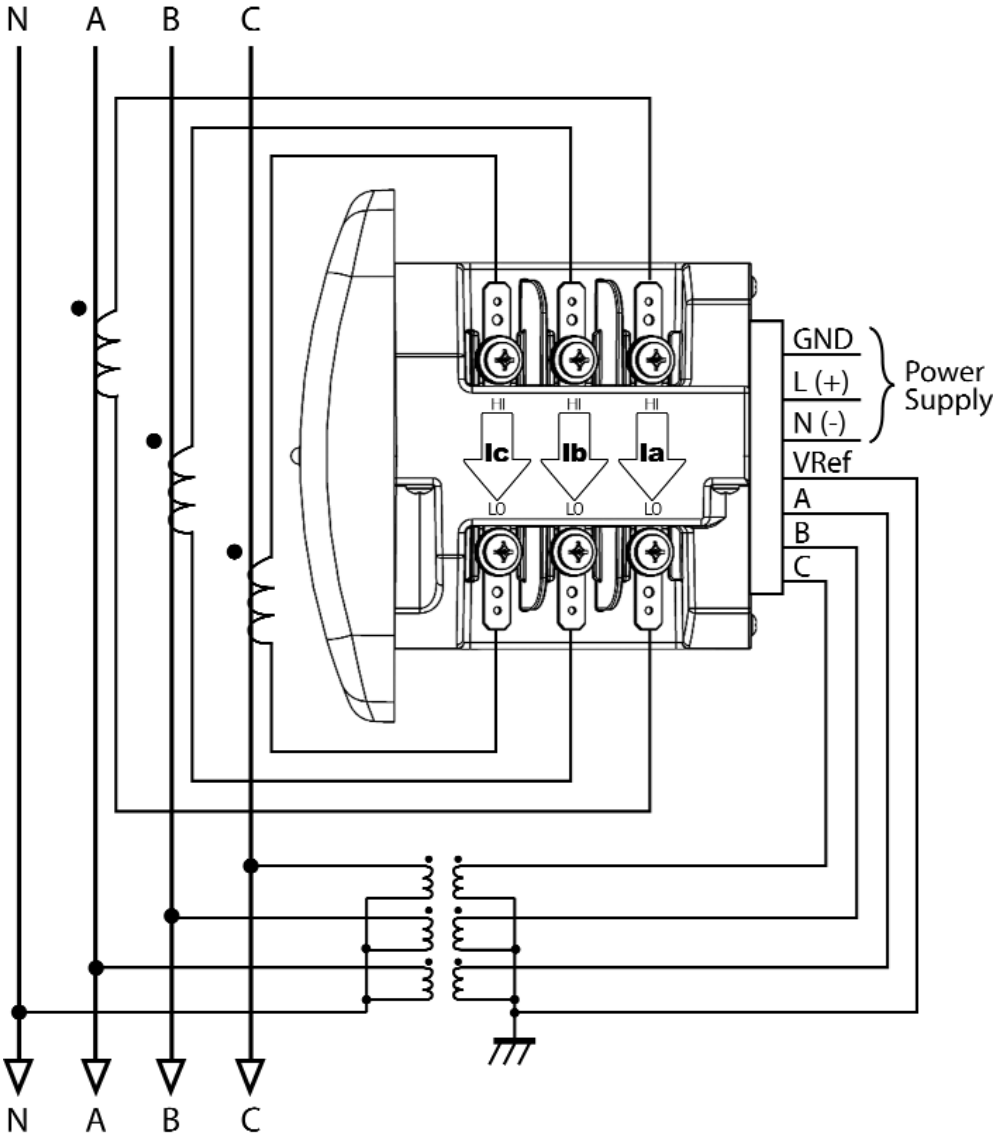

Select: "3 EL WYE" (3 Element Wye) in Meter Programming setup.

4. Service: 2.5 Element WYE, 4-Wire with 2 PTs, 3 CTs

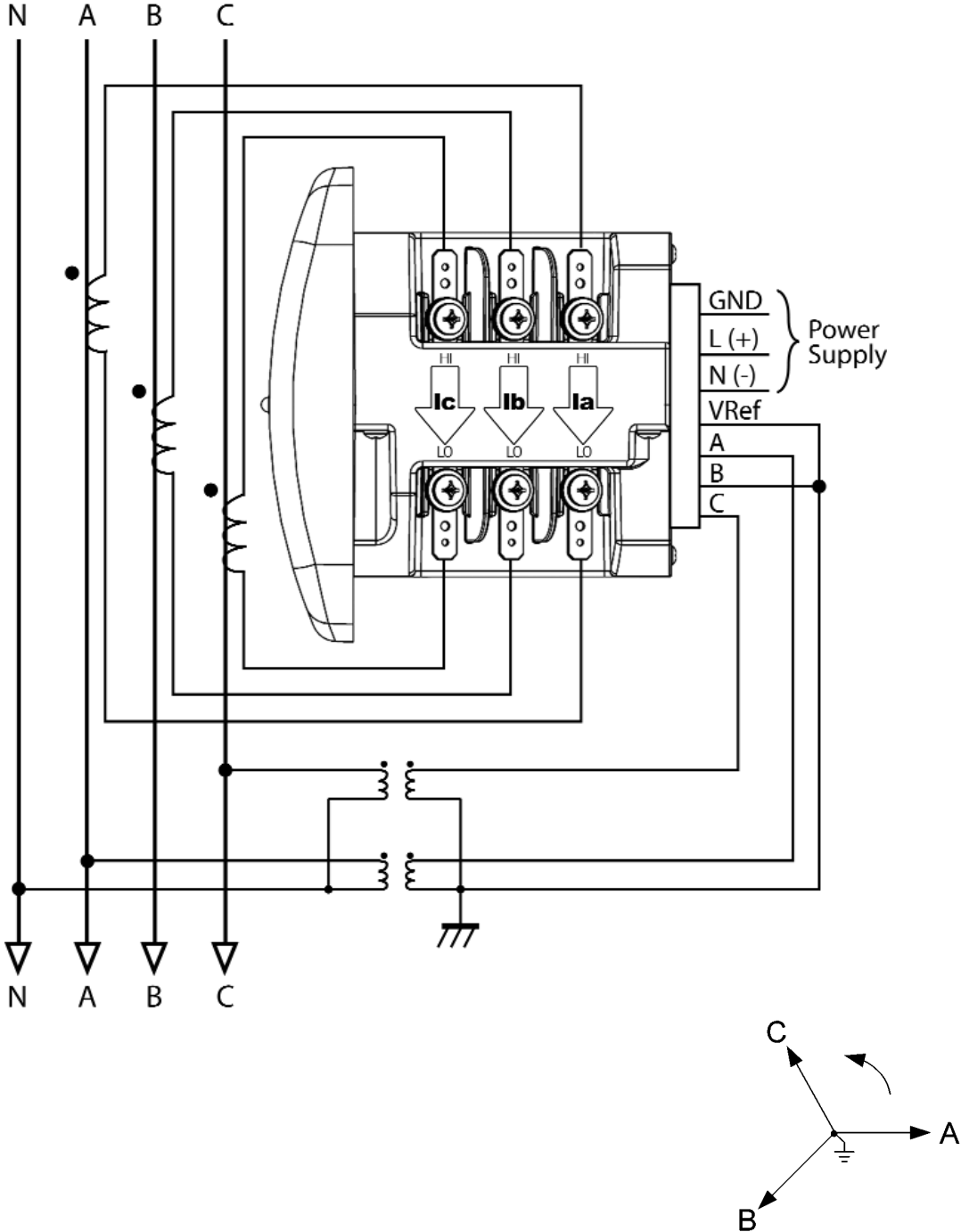

Select: "2.5 EL WYE" (2.5 Element Wye) in Meter Programming setup.

5. Service: Delta, 3-Wire with No PTs, 2 CTs

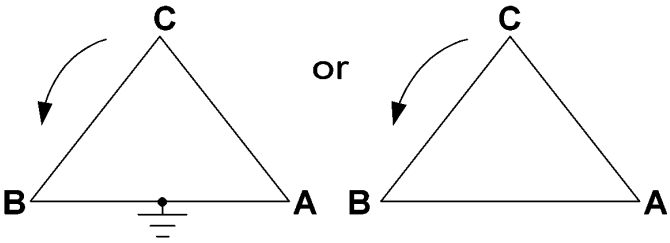
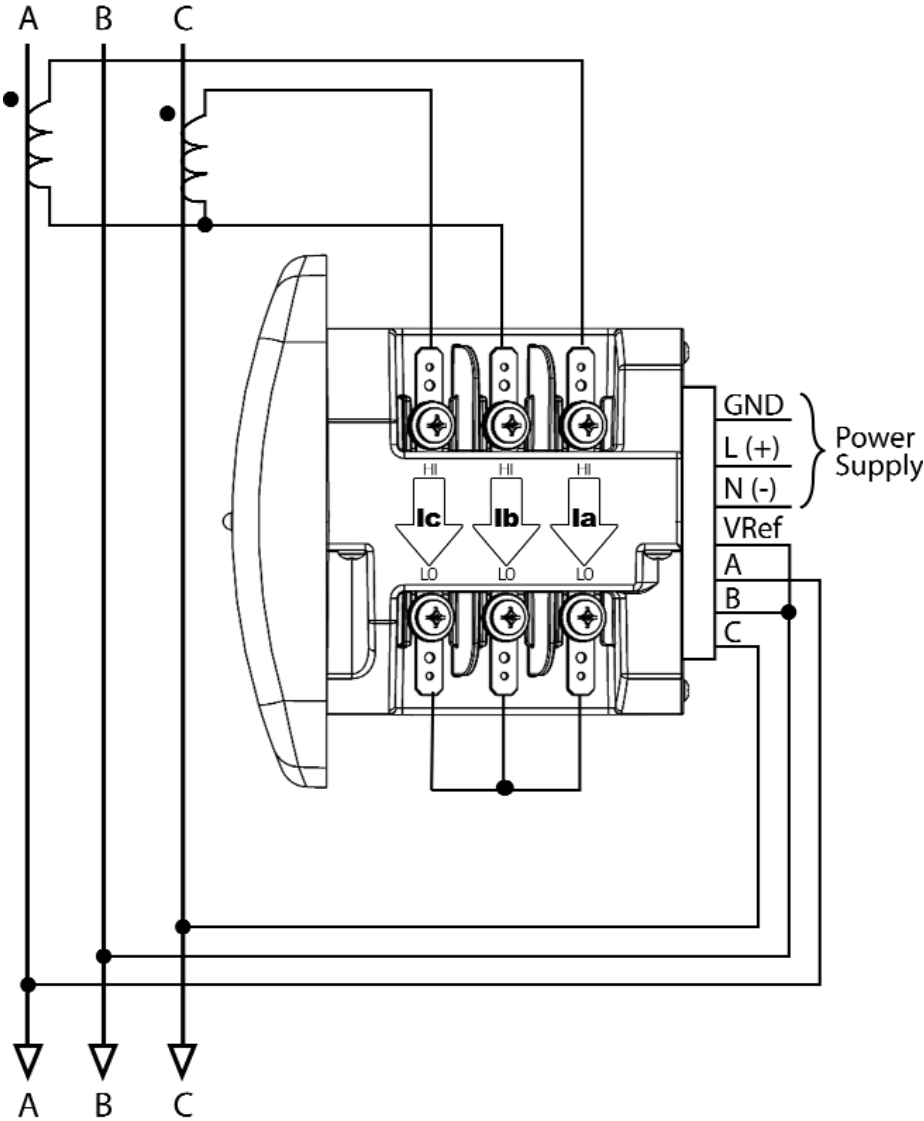

Select: "2 Ct dEL" (2 CT Delta) in Meter Programming setup.

6. Service: Delta, 3-Wire with 2 PTs, 2 CTs

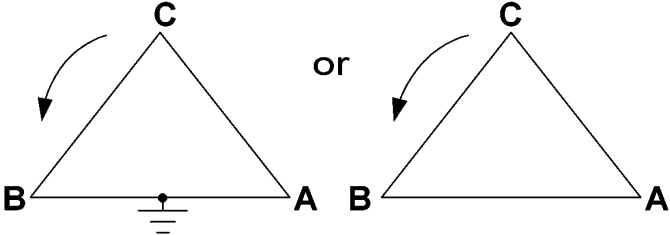
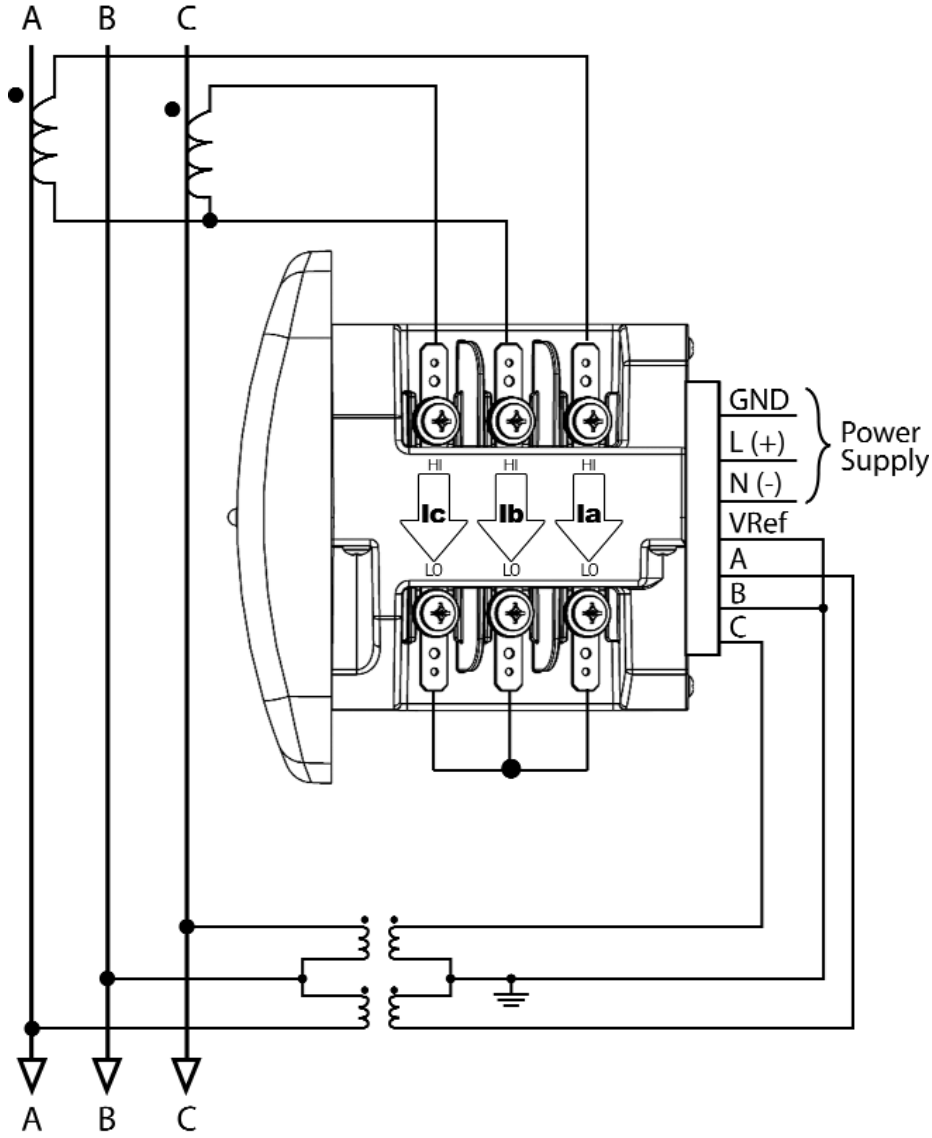

Select: "2 Ct dEL" (2 CT Delta) in Meter Programming setup.

7. Service: Delta, 3-Wire with 2 PTs, 3 CTs

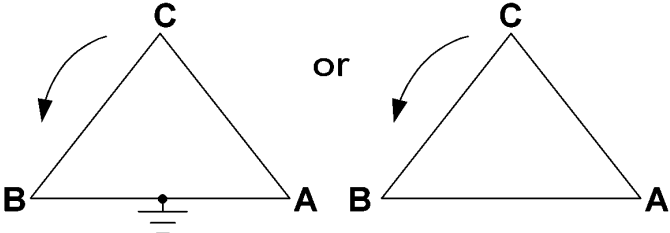
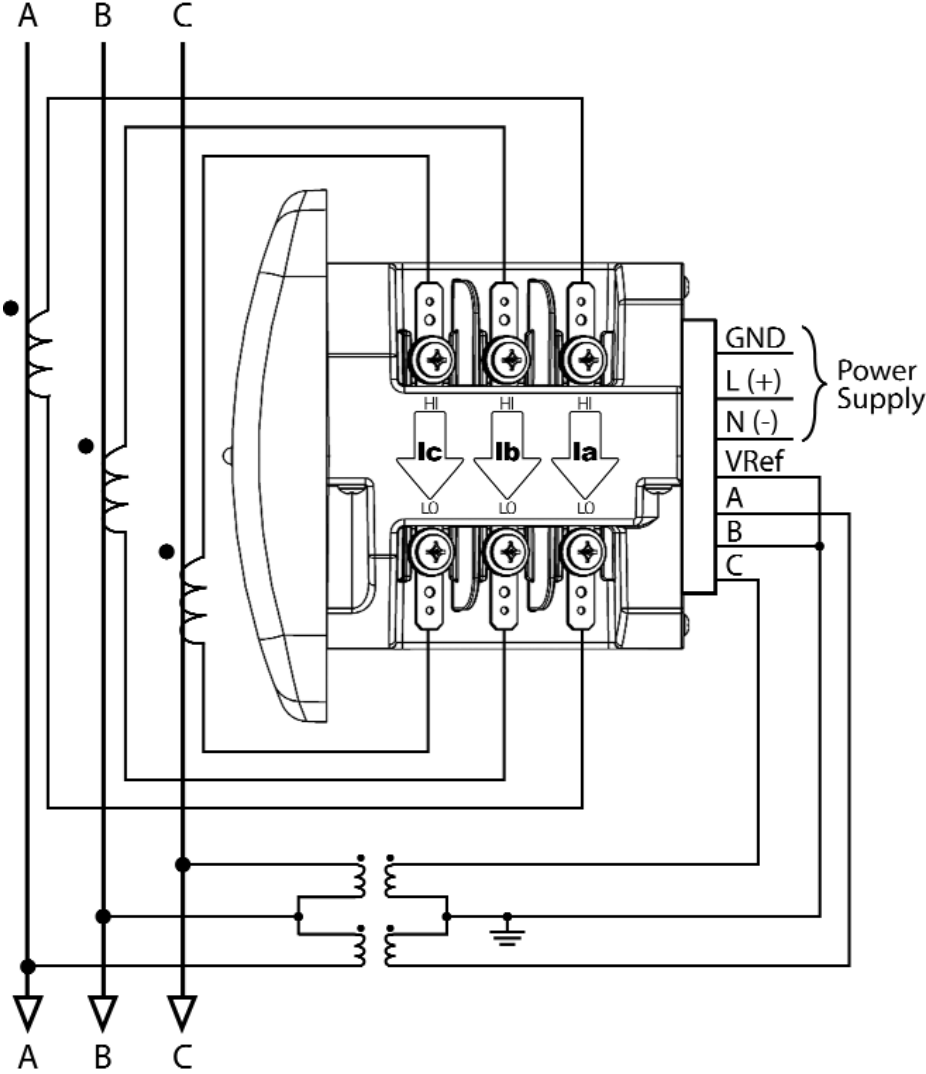

Select: "2 Ct dEL" (2 CT Delta) in Meter Programming setup.

NOTE: The third CT for hookup is optional and is for Current Measurement only.

8. Service: Current Only Measurement (Three Phase)

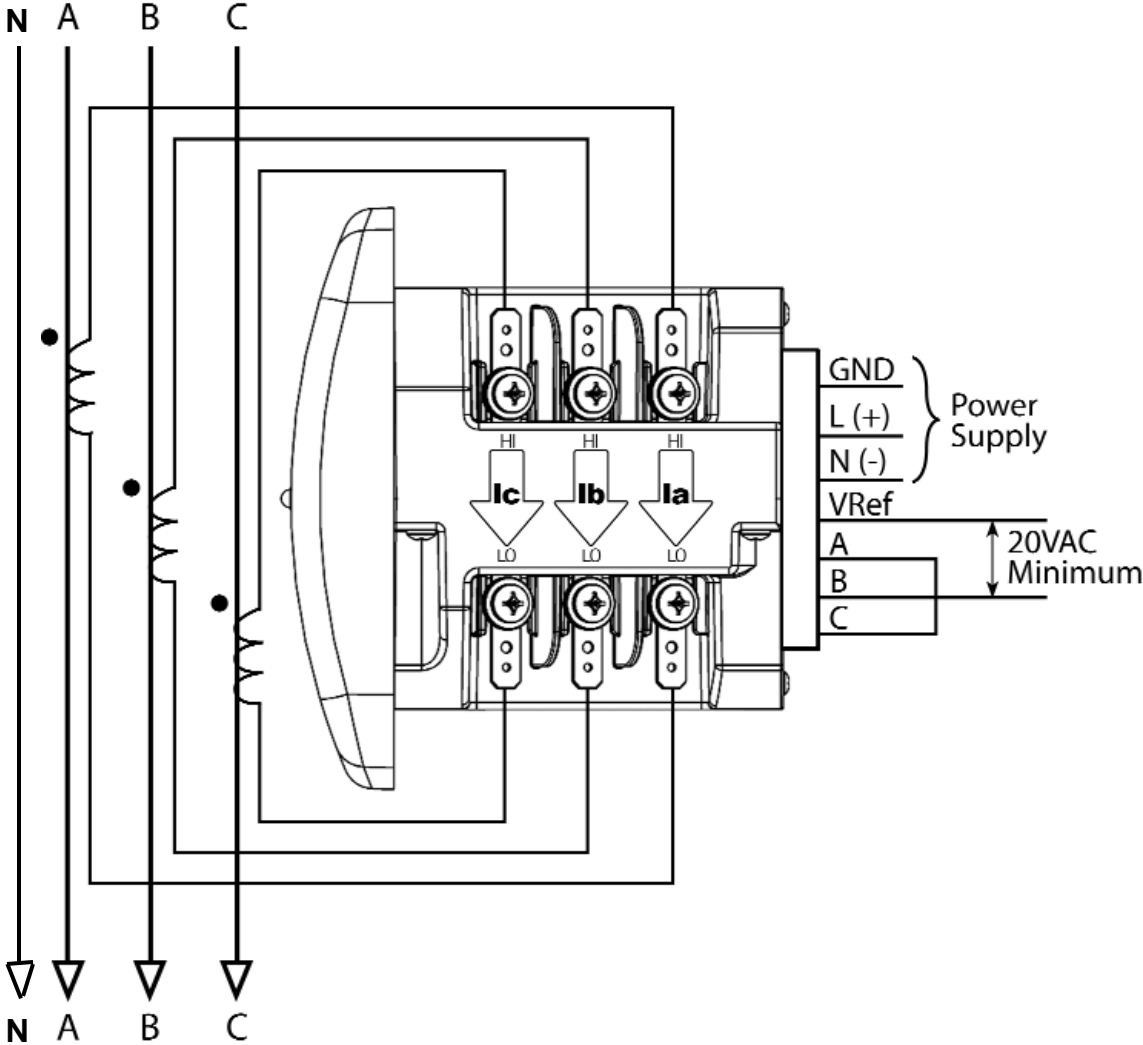

Select: "3 EL WYE" (3 Element Wye) in Meter Programming setup.

- * Even if the meter is used for only amp readings, the unit requires a Voltage reference. Please make sure that the voltage input is attached to the meter. AC Control Power can be used to provide the Reference Signal.

9. Service: Current Only Measurement (Dual Phase)

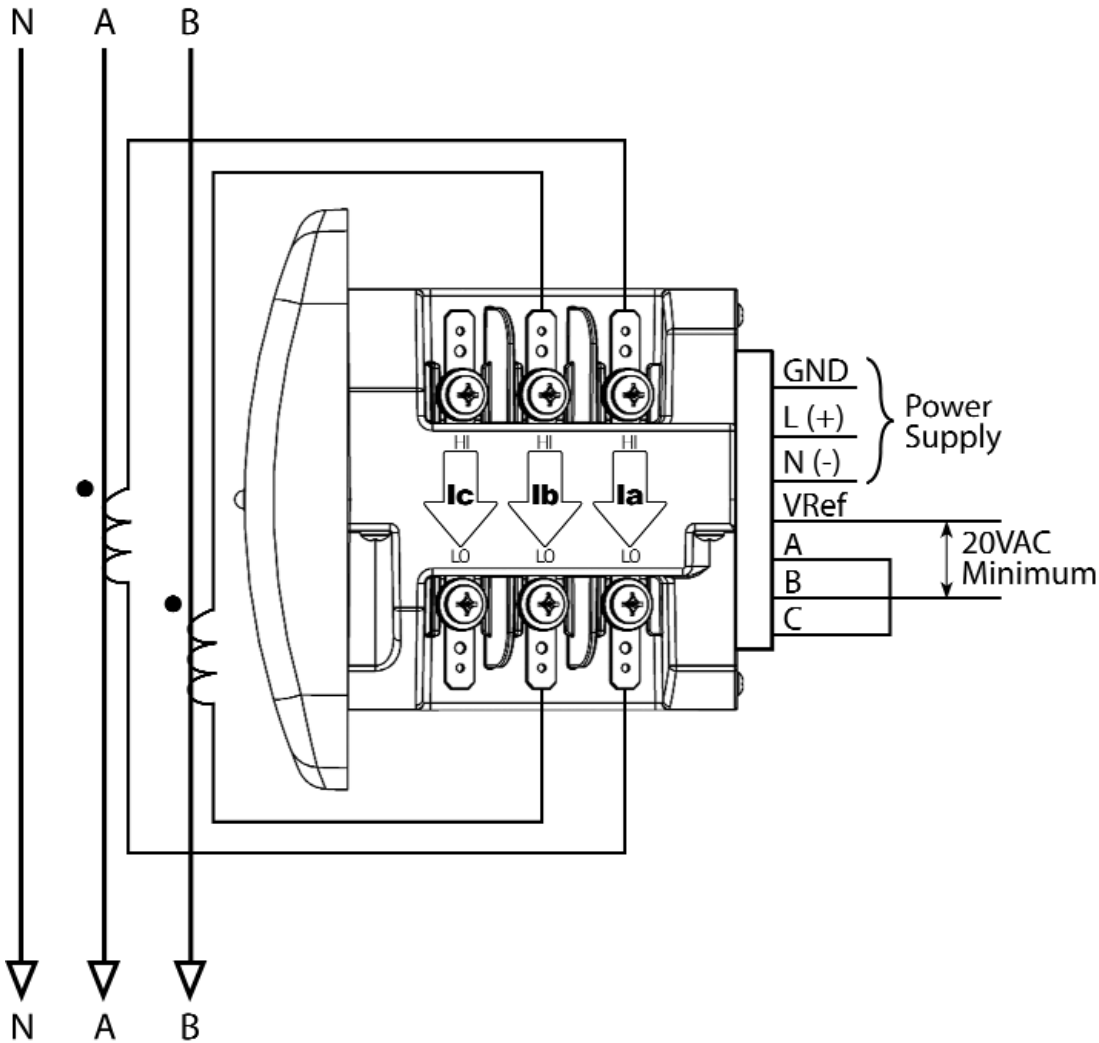

Select: "3 EL WYE" (3 Element Wye) in Meter Programming setup.

* Even if the meter is used for only amp readings, the unit requires a Voltage reference. Please make sure that the voltage input is attached to the meter. AC Control Power can be used to provide the Reference Signal.

10. Service: Current Only Measurement (Single Phase)

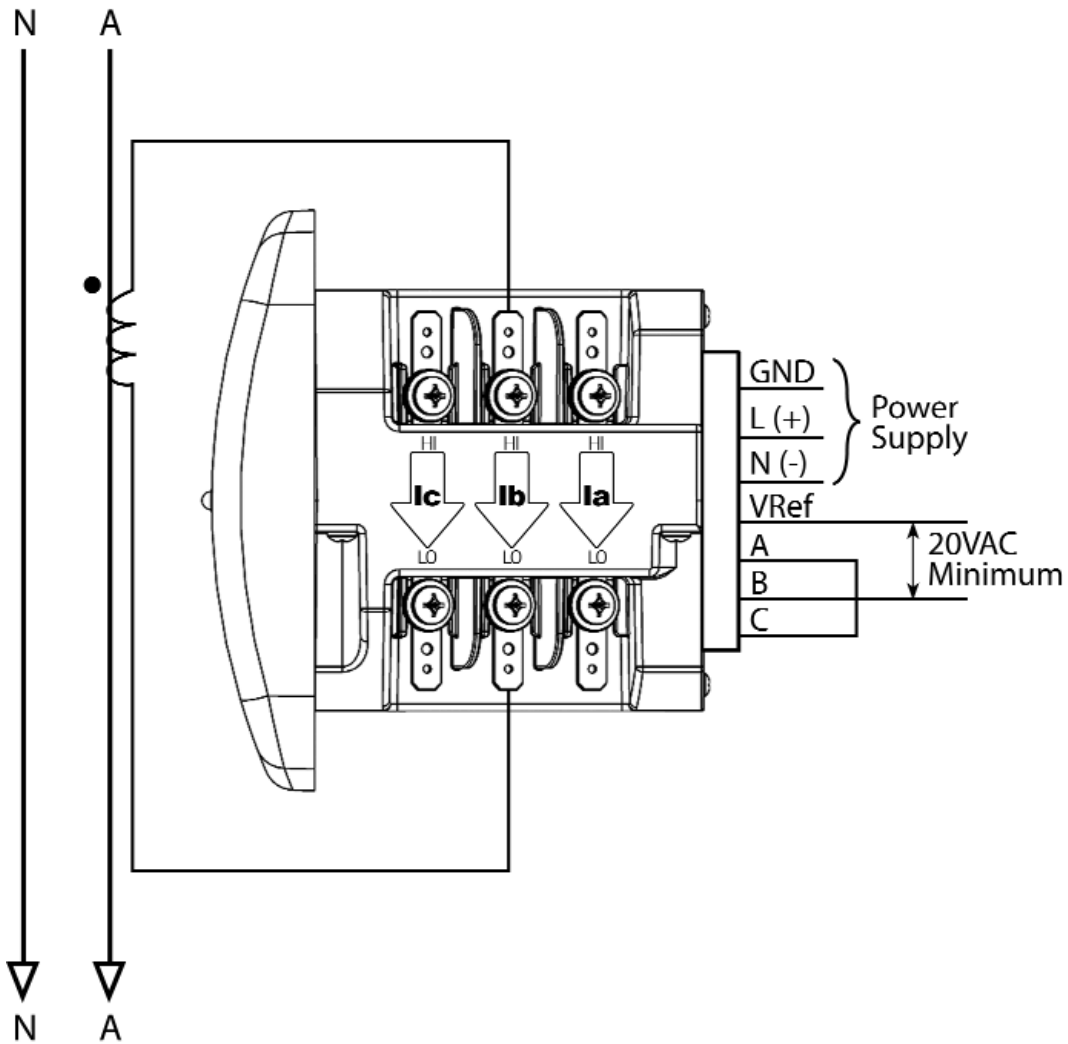

Select: "3 EL WYE" (3 Element Wye) in Meter Programming setup.

* Even if the meter is used for only amp readings, the unit requires a Voltage reference. Please make sure that the voltage input is attached to the meter. AC Control Power can be used to provide the Reference Signal.

Chapter 5

Communication Installation

5.1: Shark 100 Communication

- The Shark 100 meter provides two independent Communication Ports. The first port, Com 1, is an Optical IrDA Port. The second port, Com 2, provides RS-485 communication speaking Modbus ASCII, Modbus RTU and DNP 3.0 (V3 and V4) protocols.

5.1.1: IrDA Port (Com 1)

- The Shark 100 meter's Com 1 IrDA Port is on the face of the meter. The IrDA Port allows the unit to be set up and programmed using a PDA or remote laptop without the need for a communication cable. Just point at the meter with an IrDA-equipped PC or PDA and configure it.
- Communicator EXT COPILOT is a Windows CE software package that works with the Shark's IrDA Port to configure the port and poll readings. Refer to the *Communicator EXT User's Manual* for details on programming and accessing readings.



Figure 5.1: Simultaneous Dual Communication Paths

- Settings for Com 1 (IrDA Port) are configured using Communicator EXT software. This port communicates via Modbus ASCII Protocol ONLY.

5.1.2: RS-485 Communication Com 2 (485 Option)

- The Shark 100 meter's RS-485 port uses standard 2-Wire, Half Duplex Architecture. The RS-485 connector is located on the terminal section of the Shark 100. A connection can easily be made to a Master Device or to other Slave Devices, as shown below.
- Care should be taken to connect + to + and - to - connections.

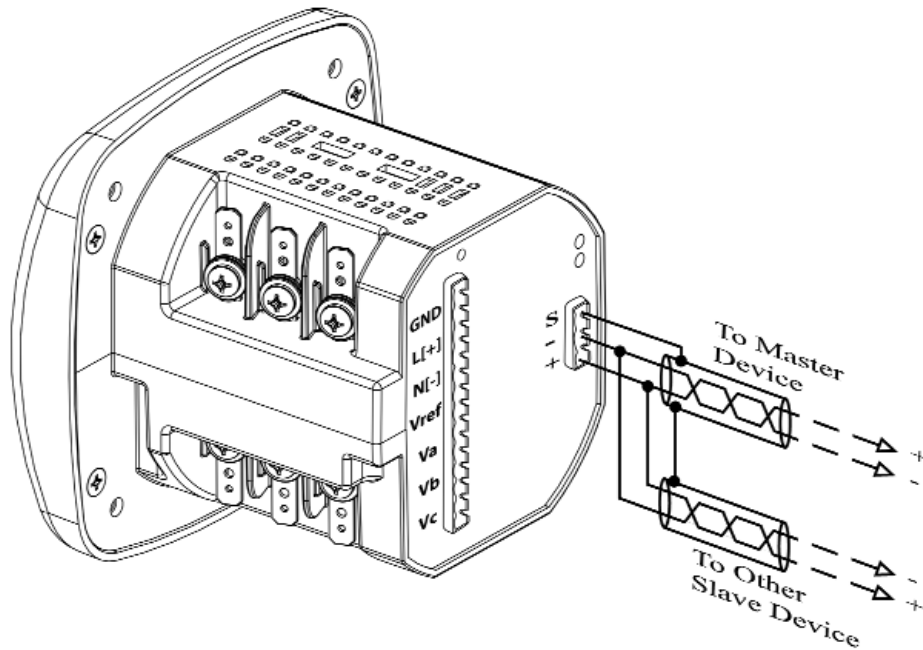

Figure 5.2: RS-485 Communication Installation

- The Shark 100 meter's RS-485 can be programmed with the buttons on the face of the meter or by using Communicator EXT 3.0 software.

Standard RS-485 Port Settings:

Address:	001 to 247
Baud Rate:	9600, 19200, 38400 or 57600
Protocol:	Modbus RTU, Modbus ASCII, DNP 3.0 (V3 and V4 Only)

NOTE: This option is not currently available.

The RS-485 Option is combined with Pulse Output in the RS-485P Option. (See section 5.1.3.)

5.1.3: RS-485 / KYZ Output Com 2 (485P Option)

- The 485P Option provides a combination RS-485 and a KYZ Pulse Output for pulsing energy values. The RS-485 / KYZ Combo is located on the terminal section of the meter.
- See section 2.2 for the **KYZ Output Specifications**. See section 6.3.1 for **Pulse Constants**.

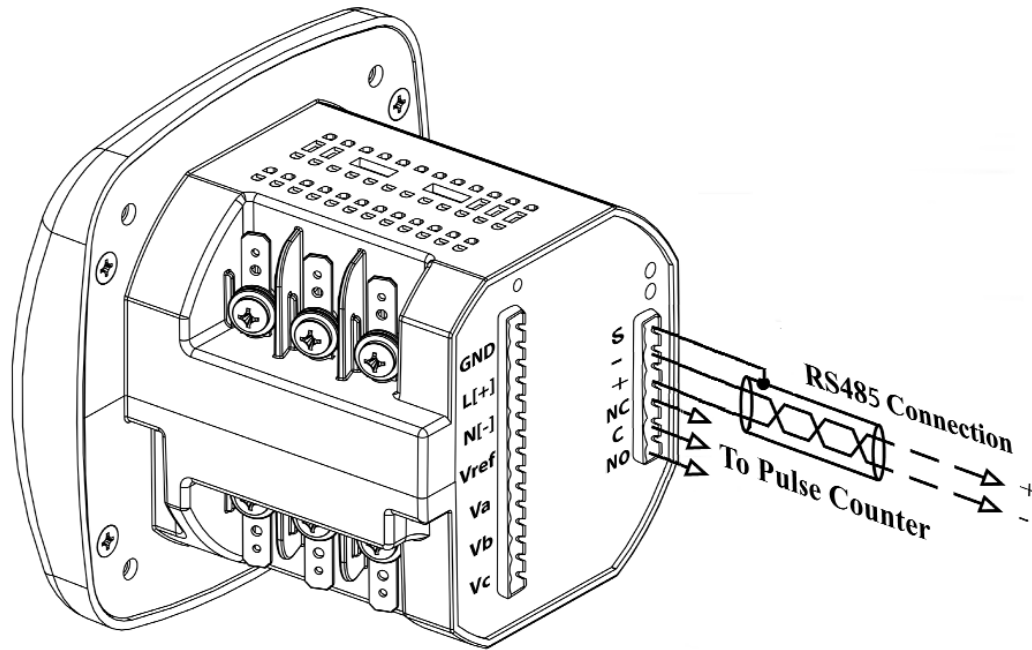

Figure 5.3: 485P Option with RS-485 Communication Installation

RS485 allows you to connect one or multiple Shark 100 meters to a PC or other device, at either a local or remote site. All RS485 connections are viable for up to 4000 feet (1219.20 meters).

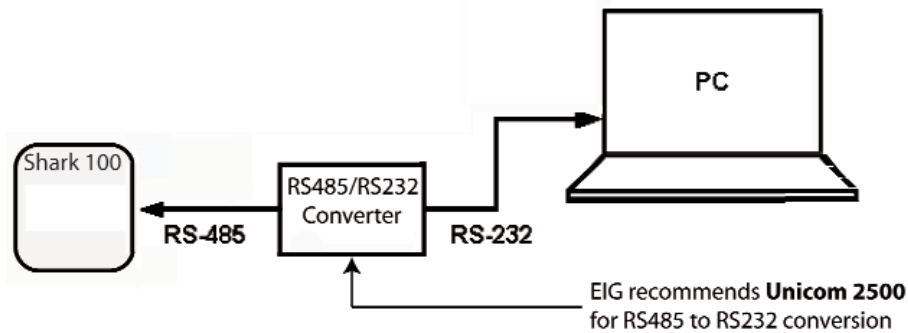

Figure 5.4: Shark 100 Connected to PC via RS485

As shown in Figure 5.4, to connect a Shark 100 to a PC, you need to use an RS485 to RS232 converter, such as EIG's Unicom 2500. See Section 5.1.3.1 for information on using the Unicom 2500 with the Shark 100.

Figure 5.5 shows the detail of a 2-wire RS485 connection.

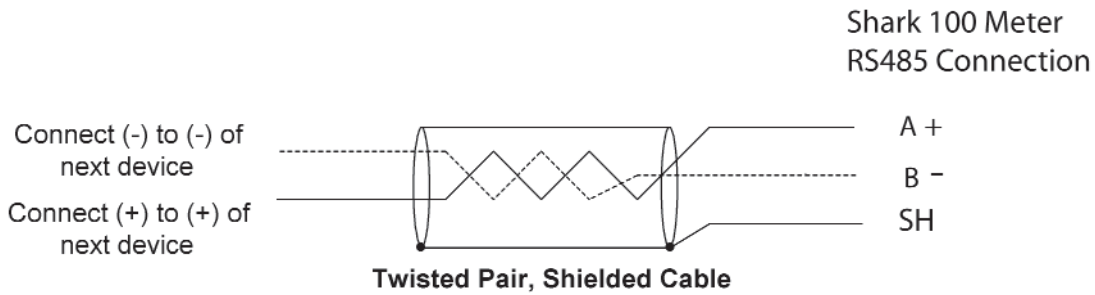

Figure 5.5: 2-wire RS485 Connection

NOTES:

For All RS485 Connections:

- Use a shielded twisted pair cable 22 AWG (0.33 mm²) or larger, grounding the shield at one end only.
- Establish point-to-point configurations for each device on a RS485 bus: connect (+) terminals to (+) terminals; connect (-) terminals to (-) terminals.
- You may connect up to 31 meters on a single bus using RS485. Before assembling the bus, each meter must be assigned a unique address: refer to Chapter 5 of the Communicator EXT User’s Manual for instructions.
- Protect cables from sources of electrical noise.
- Avoid both “Star” and “Tee” connections (see Figure 5.7).
- No more than two cables should be connected at any one point on an RS485 network, whether the connections are for devices, converters, or terminal strips.
- Include all segments when calculating the total cable length of a network. If you are not using an RS485 repeater, the maximum length for cable connecting all devices is 4000 feet (1219.20 meters).
- Connect shield to RS485 Master and individual devices as shown in Figure 5.6. You may also connect the shield to earth-ground at one point.
- Termination Resistors (RT) may be needed on both ends of longer length transmission lines. However, since the meter has some level of termination internally, Termination Resistors may not be needed. When they are used, the value of the Termination Resistors is determined by the electrical parameters of the cable.

Figure 5.6 shows a representation of an RS485 Daisy Chain connection. Refer to Section 5.1.2.1 for details on RS485 connection for the Unicom 2500.

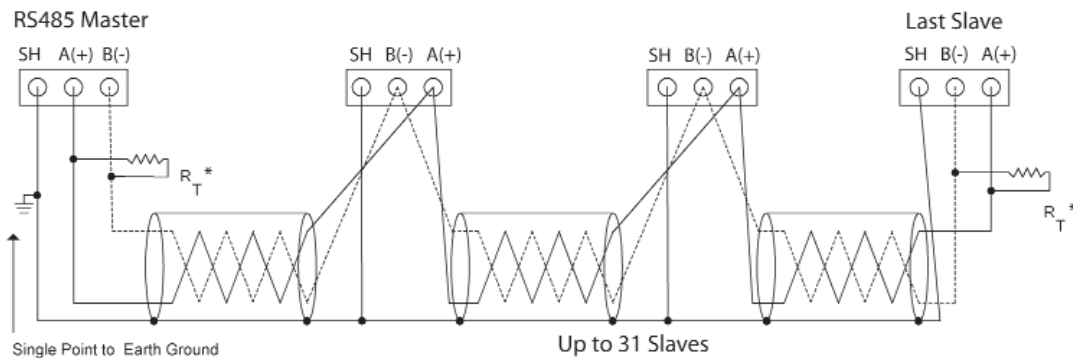

Figure 5.6: RS485 Daisy Chain Connection

Incorrect Configuration: "T"



"Tee" Connection Incorrect!

The three wires connected in a "T" shape on both the (+) and (-) terminals will cause interference problems.

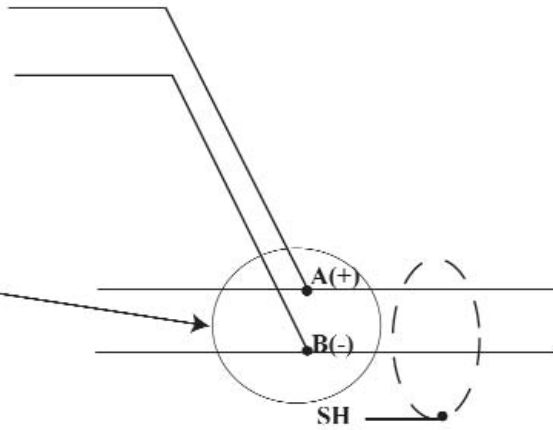

Incorrect Configuration: "Star"



"Star" Connection Incorrect!

The three wires connected in a "Star" shape on both the (+) and (-) terminals will cause interference problems.

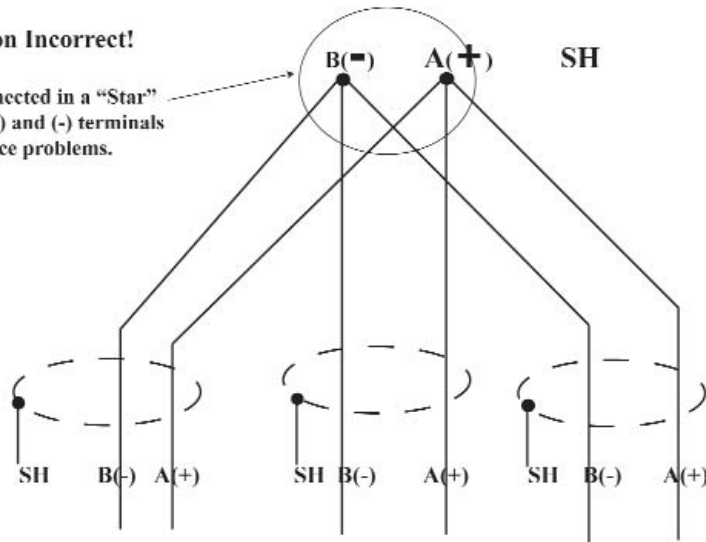

Figure 5.7: Incorrect "T" and "Star" Topologies

5.1.3.1: Using the Unicom 2500

The Unicom 2500 provides RS485/RS232 conversion. In doing so it allows a Shark 100 with the RS485 option to communicate with a PC. See the *Unicom 2500 Installation and Operation Manual* for additional information.

Figure 5.8 illustrates the Unicom 2500 connections for RS485.

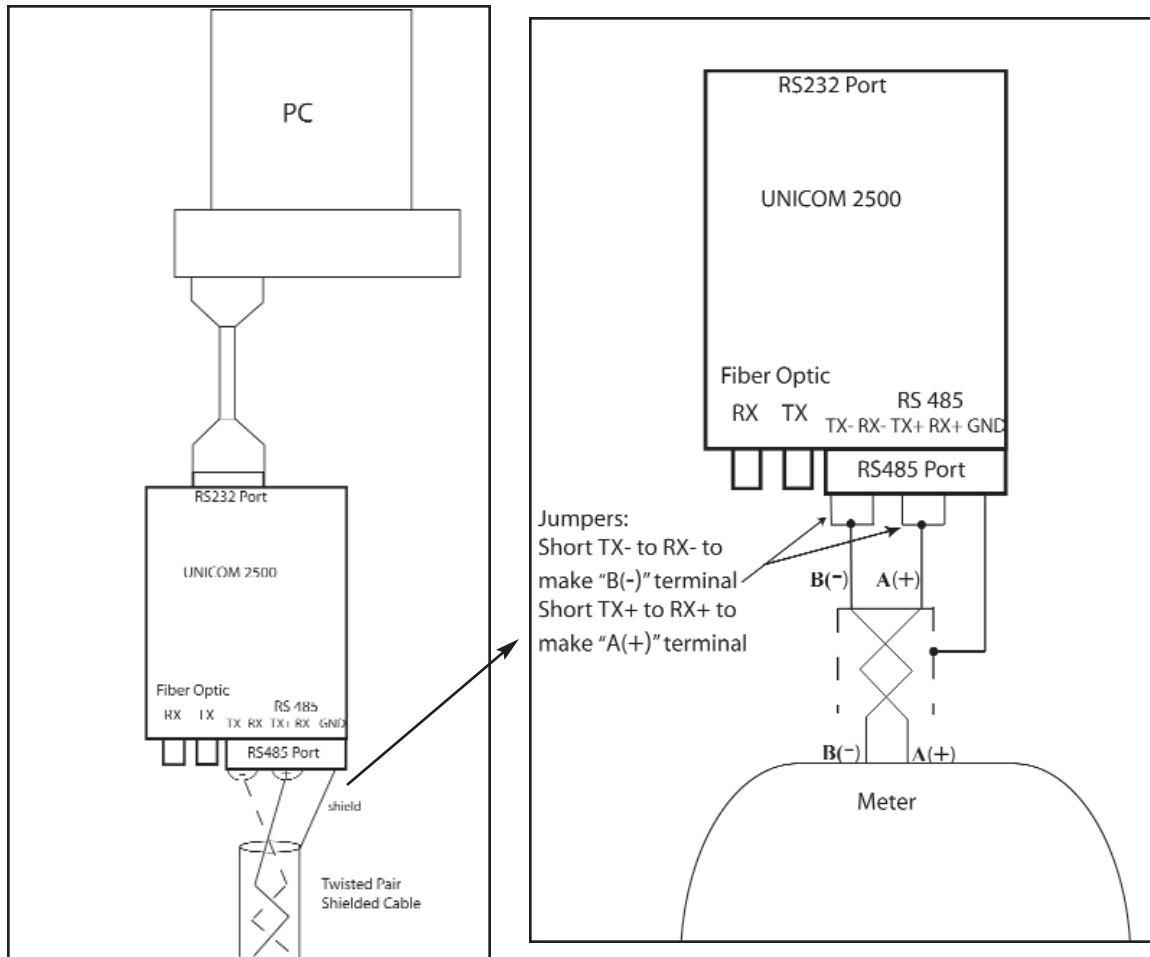

Figure 5.8: Unicom 2500 with Connections

Figure 5.9: Detail of "Jumpers"

The Unicom 2500 can be configured for either 4-wire or 2-wire RS485 connections. Since the Shark 100 uses a 2-wire connection, you need to add jumper wires to convert the Unicom 2500 to the 2-wire configuration.

As shown in Figure 5.9, you connect the "RX -" and "TX -" terminals with a jumper wire to make the "B(-)" terminal, and connect the "RX +" and "TX +" terminals with a jumper wire to make the "A(+)" terminal.

5.2: Shark 100T Communication and Programming Overview

- The Shark 100T Transducer model does not include a display on the front face of the meter. So, there are no buttons or IrDA Port on the face of the meter. Programming and communication utilize the RS-485 connection on the back face of the meter shown in section 5.1.2. Once a connection is established, Communicator EXT 3.0 software can be used to program the meter and communicate to Shark 100T slave devices.

■ Meter Connection

To provide power to the meter, use one of the wiring diagrams in Chapter 4 or attach an Aux cable to GND, L(+) and N(-).

The RS-485 cable attaches to SH, B(-) and A(+) as shown in section 5.1.2.

5.2.1: Factory Initial Default Settings

- You can connect to the Shark 100T using the Factory Initial Default Settings. This feature is useful in debugging or in any situation where you do not know the meter's programmed settings and want to find them.

When the Shark 100T is powered up, you have up to **5 seconds** to poll the Name Register as shown in the example below: "How to Connect." You will be connected to the meter with the Factory Initial Default Settings. The meter continues to operate with these default settings for 5 minutes. During this time, you can access the meter's Device Profile to ascertain/change meter information. After the 5 minutes have passed, the meter reverts to the programmed Device Profile settings.

NOTE:

■ Factory Initial Default Settings

Baud Rate: 9600
Port: COM1
Protocol: Modbus RTU

■ How to Connect

1. Open **Communicator EXT** software.
2. Click the **Connect** button on the tool bar.

The **Connect** screen appears, showing the **Default** settings. Make sure your settings are the same as shown here. Use the pull-down windows to make changes, if necessary.

3. Click the **Connect** button on the screen.

NOTE If you do not connect with the Factory Initial Default Settings within 5 seconds after powering on the meter, the Device Profile reverts to the programmed Device Profile. In that case, disconnect and reconnect power before clicking the Connect button.

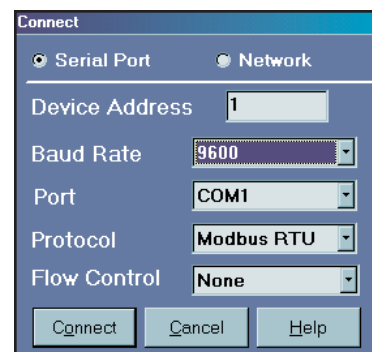
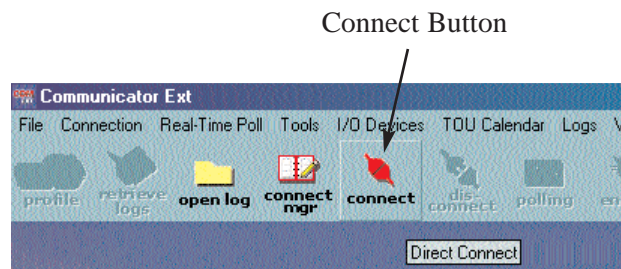

The Device Status screen appears, confirming a connection.

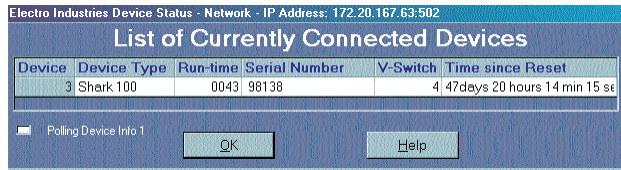

Click OK.
The main screen of Communicator EXT software reappears.

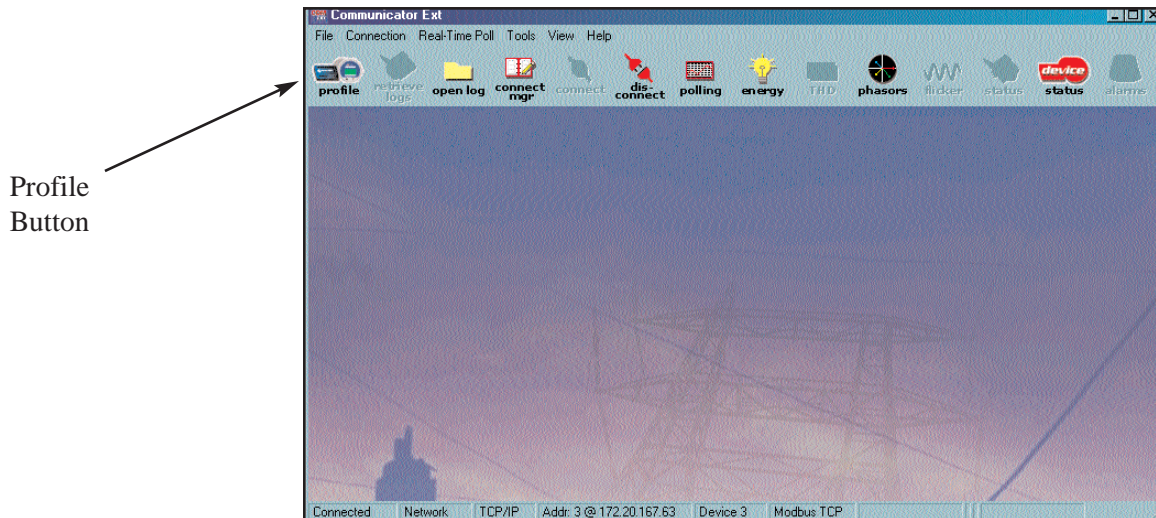

Profile Button

4. Click the **Profile** button on the toolbar.
A set of Shark Profile Programming Screens appears.

5. Click the **Communication tab**.
The Communication Settings appear.
Use pull-down menus to change settings, if desired.

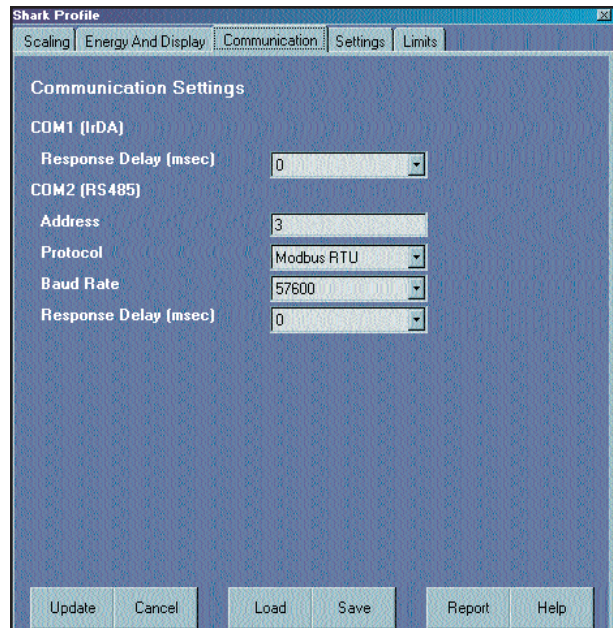

■ **Communication Settings**

COM1 (IrDA)

Response Delay (0-750 msec)

COM2 (RS485)

Address (1-247)
Protocol (Modbus RTU, ASCII or DNP)
Baud Rate (9600 to 57600)
Response Delay (0-750 msec)

6. When changes are complete, click the **Update** button to send a new profile to the meter.

7. Click **Cancel** to Exit the Profile (or)

8. Click other tabs to update other aspects of the Profile (see section 5.2.2 below).

5.2.2: Shark Profile Settings

■ Scaling (CT, PT Ratios and System Wiring)

CT Numerator (Primary):

CT Denominator (Secondary):

CT Multiplier:

CT Fullscale:

Calculation Based on Selections

PT Numerator (Primary):

PT Denominator (Secondary):

PT Multiplier:

PT Fullscale:

Calculation Based on Selections

System Wiring:

Number of Phases: One, Two or Three

NOTE:

VOLTS FULL SCALE = PT Numerator x PT Multiplier

WARNING:

**You must specify Primary and Secondary Voltage in Full Scale. Do not use ratios!
The PT Denominator should be the Secondary Voltage level.**

Example:

A 14400/120 PT would be entered as:

PT Num: 1440

PT Denom: 120

Multiplier: 10

This example would display a 14.40kV.

■ Example CT Settings:

200/5 Amps:

Set the Ct-n value for 200, Ct-Multiplier value for 1.

800/5 Amps:

Set the Ct-n value for 800, Ct-Multiplier value for 1.

2,000/5 Amps:

Set the Ct-n value for 2000, Ct-Multiplier value for 1.

10,000/5 Amps:

Set the Ct-n value for 1000, Ct-Multiplier value for 10.

■ Example PT Settings:

277/277 Volts

Pt-n value is 277, Pt-d value is 277, Pt-Multiplier is 1.

14,400/120 Volts:

Pt-n value is 1440, Pt-d value is 120, Pt-Multiplier value is 10.

138,000/69 Volts:

Pt-n value is 1380, Pt-d value is 69, Pt-Multiplier value is 100.

345,000/115 Volts:

Pt-n value is 3470, Pt-d value is 115, Pt-Multiplier value is 100

345,000/69 Volts:

Pt-n value is 345, Pt-d value is 69, Pt-Multiplier value is 1000.

NOTE: Settings are the same for Wye and Delta configurations.

■ **Energy and Display**
Power and Energy Format

Power Scale

Energy Digits

Energy Decimal Places

Energy Scale

(Example Based on Selections)

Power Direction: View as Load

Demand Averaging

Averaging Method: Block or Rolling

Interval (Minutes)

Sub Interval

Auto Scroll: Click to Activate

Display Configuration:

Click Values to be displayed.

NOTE: You MUST have at least ONE selected.

NOTE: For Shark 100T, the Display Configuration section does not apply because there is no display.

NOTE: If incorrect values are entered on this screen the following message appears:

WARNING: Current, CT, PT and Energy Settings will cause invalid energy accumulator values.
Change the inputted settings until the message disappears.

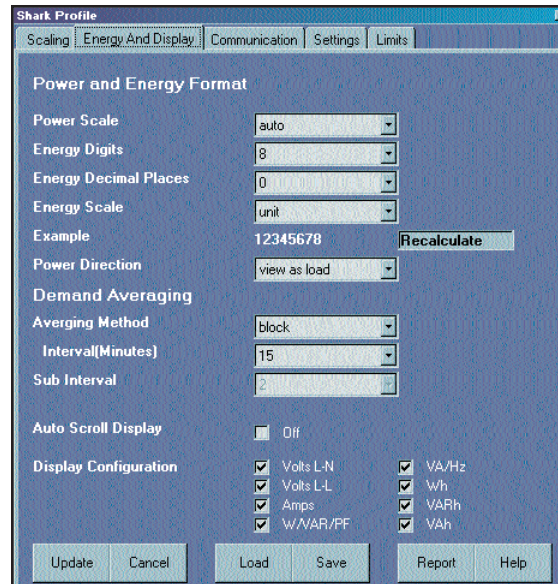

■ **Settings**

Password

(Meter is shipped with Password Disabled and there is NO DEFAULT PASSWORD)

- Enable Password for Reset
- Enable Password for Configuration
- Change Password

Change VSwitch

(Call Electro Industries for Update Information)

Change Device Designation

■ **Limits (VSwitch 4 Only)**

- For up to 8 Limits, Set:
- Address: Modbus Address (1 based)
- Label: Your Designation
- High Set Point: % of Full Scale
- Example: 100% of 120VFS = 120V
- 90% of 120V FS = 108V

Return Hysteresis: Point to go back in Limit

- Example: High Set Point = 110%
- (Out of Limit at 132V)
- Return Hysteresis = 105%
- (Stay Out until 126V)

Low Set Point: % of Full Scale

Return Hysteresis: Point to go back in Limit

Settings appear in the Table at the bottom of the screen

NOTE: If Return Hysteresis is > High Set Point, the Limit is Disabled.

Click **Update** to send a new Profile.

NOTE: If the Update fails, the software asks if you want to try again to Update. Click **Cancel** to Exit the Profile.

Use Communicator EXT to communicate with the device and perform required tasks.

Refer to the *Communicator EXT User's Manual* for more details.

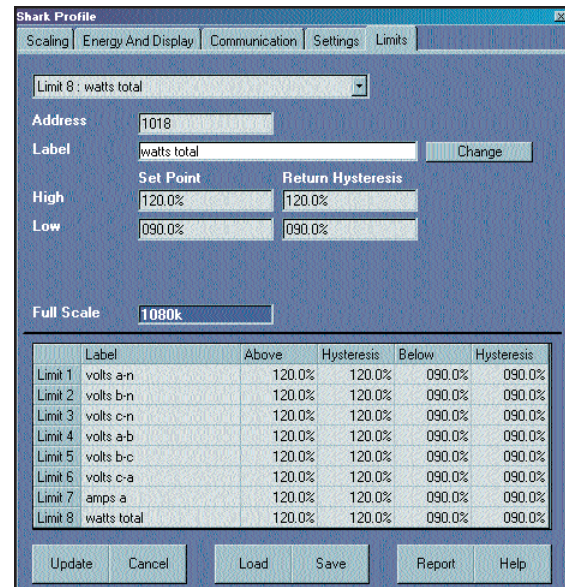
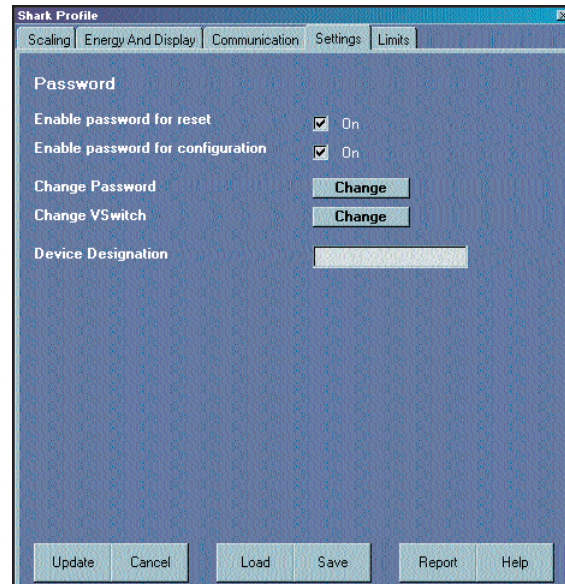

Chapter 6

Using the Meter

6.1: Introduction

- The Shark 100 meter can be configured and a variety of functions can be accomplished simply by using the Elements and the Buttons on the meter face. This chapter will review Front Panel Navigation. Complete Navigation Maps can be found in Appendix A of this manual.

6.1.1: Meter Face Elements

- **Reading Type Indicator:**
Indicates Type of Reading
- **IrDA Communication Port:**
Com 1 Port for Wireless Communication
- **% of Load Bar:**
Graphic Display of Amps as % of the Load
- **Parameter Designator:**
Indicates Reading Displayed
- **Watt-Hour Test Pulse:**
Energy Pulse Output to Test Accuracy
- **Scale Selector:**
Kilo or Mega multiplier of Displayed Readings

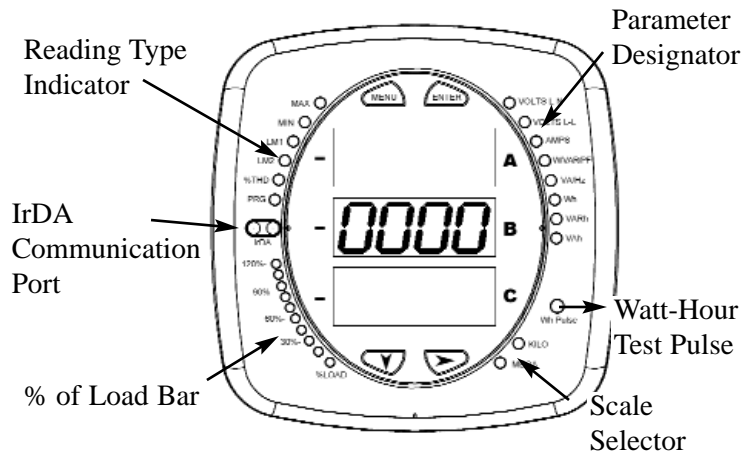

Figure 6.1: Face Plate of Shark 100 with Elements

6.1.2: Meter Face Buttons

- Using **Menu, Enter, Down and Right Buttons**, perform the following functions:

- View Meter Information
- Enter Display Modes
- Configure Parameters (Password Protected)
- Perform Resets
- Perform LED Checks
- Change Settings
- View Parameter Values
- Scroll Parameter Values
- View Limit States

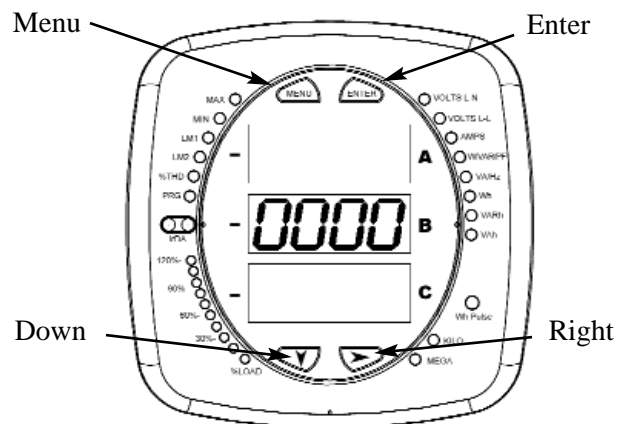

Figure 6.2: Face Plate of Shark 100 with Buttons

- **Enter Button:** Press and release to enter one of four Display Modes
 Operating Mode (Default),
 Reset Mode (ENTER once, then Down)
 Settings Mode (ENTER twice, then Down) and
 Configuration Mode (ENTER three times, then Down)
- **Menu Button:** Press and release to navigate Config Menu, return to Main Menu
- **Right Button:** Operating Mode - Max, Min, %THD, Del kW, Net kW, Total kW
 Reset Mode - Yes, No
 Settings Mode - On, Off, Settings
 Config Mode - Password Digits, Available Values, Digits
- **Down Button:** Scroll DOWN through Mode menus
- **Use Buttons in Modes of Operation:**
 Operating Mode (default): View Parameter Values
 Reset Mode: Reset Stored Max and Min Values
 Settings Mode: View Meter Setting Parameters and Change Scroll Setting
 Configuration Mode: Change Meter Configuration (Can be Password Protected)

NOTE: The above is a brief overview of the use of the Buttons. For Programming, refer to Chapter 7.
 For complete Navigation Maps, refer to Appendix A of this manual.

6.2: % of Load Bar

- The 10-segment LED bargraph at the bottom of the Shark display provides a graphic representation of Amps. The segments light according to the load in the %Load Segment Table below.
 When the Load is over 120% of Full Load, all segments flash “On” (1.5 secs) and “Off” (0.5 secs).

% Load Segment Table	
Segments	Load >= % Full Load
none	no load
1	1%
1 - 2	15%
1 - 3	30%
1 - 4	45%
1 - 5	60%
1 - 6	72%
1 - 7	84%
1 - 8	96%
1 - 9	108%
1 - 10	120%
All Blink	>120%

6.3: Watt-Hour Accuracy Testing (Verification)

- To be certified for revenue metering, power providers and utility companies have to verify that the billing energy meter will perform to the stated accuracy. To confirm the meter's performance and calibration, power providers use field test standards to ensure that the unit's energy measurements are correct. Since the Shark 100 is a traceable revenue meter, it contains a utility grade test pulse that can be used to gate an accuracy standard. This is an essential feature required of all billing grade meters.

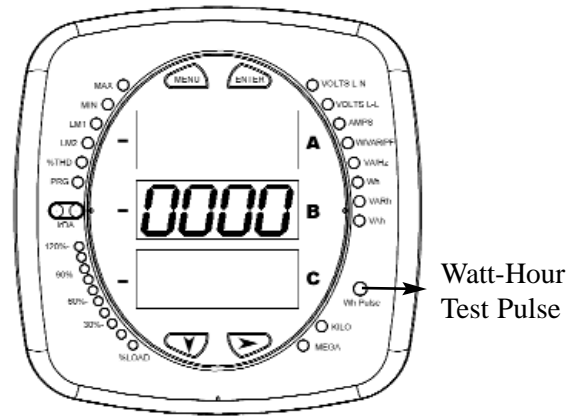

Figure 6.3: Watt-Hour Test Pulse

Refer to Figure 6.5 below for an example of how this process works.
 Refer to Figure 6.6 below for the Wh/Pulse Constant for Accuracy Testing.

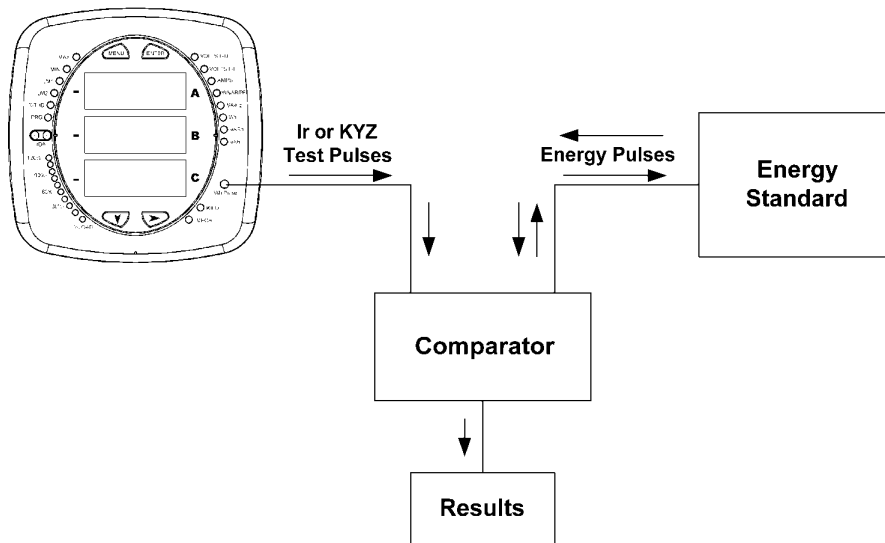

Figure 6.4: Using the Watt-Hour Test Pulse

6.3.1: Infrared & KYZ Pulse Constants for Accuracy Testing

Infrared & KYZ Pulse Constants for Accuracy Testing

Voltage Level	Class 10 Models	Class 2 Models
Below 150V	0.2505759630	0.0501151926
Above 150V	1.0023038521	0.2004607704

NOTE: Minimum pulse width is 40ms.

Figure 6.5: EPM 6000 Accuracy Test Constants

6.4: Upgrade the Meter Using V-Switches®

- The Shark 100 is equipped with V-Switch® Technology. V-Switch® is a virtual firmware-based switch that allows you to enable meter features through communication. This allows the unit to be upgraded after installation to a higher model without removing the unit from service.

- Available V-Switches®

V-Switch 1 (-V1): Volts and Amps Meter - Default

V-Switch 2 (-V2): Volts, Amps, kW, kVAR, PF, kVA, Freq

V-Switch 3 (-V3): Volts, Amps, kW, kVAR, PF, kVA, Freq., kWh, kVAh, kVARh, DNP 3.0

V-Switch 4 (-V4): Volts, Amps, kW, kVAR, PF, kVA, Freq., kWh, kVAh, kVARh, DNP 3.0,
%THD Monitoring and Limit Exceeded Alarms

- To change the V-Switch®, follow these simple steps:

1. Install Communicator EXT 3.0 in your computer.
2. Set up Shark 100 to communicate with your computer (see Chapter 5); power up your meter.
3. Log on to Communicator EXT 3.0 software.
4. Click on the Profile Icon. A set of screens appears.
5. The first screen is the Settings screen.
Click CHANGE V-SWITCH.
A small screen appears that requests a code (shown here).
6. Enter the code which EIG provides.
7. Click OK.
The V-Switch® has been changed.
The meter resets.

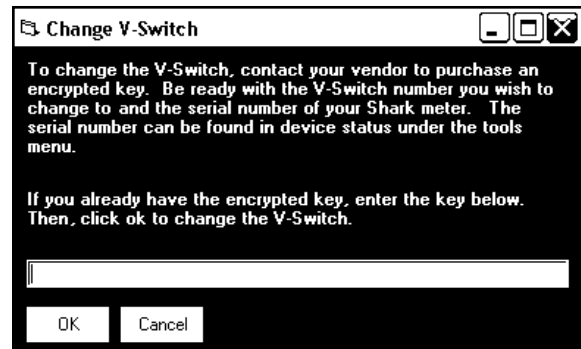

NOTE: For more details on software configuration, refer to the *Communiator EXT 3.0 User's Manual*.

- **How do I get a V-Switch?**

V-Switches are based on the particular serial number of the ordered meter. To obtain a higher V-Switch, you need to provide EIG with the following information:

1. Serial Number or Numbers of the meters for which you desire an upgrade.
2. Desired V-Switch Upgrade.
3. Credit Card or Purchase Order Number.

Contact EIG's inside sales staff with the above information at sales@electroind.com or (516) 334-0870 (USA) and EIG will issue you the Upgrade Code.

Chapter 7

Configuring the Shark Using the Front Panel

7.1: Overview

- The Shark 100 front panel can be used to configure the meter. The Shark has three MODES:

Operating Mode (Default),
Reset Mode and
Configuration Mode.

The MENU, ENTER, DOWN and RIGHT buttons navigate through the MODES and navigate through all the SCREENS in each mode.

In this chapter, a typical set up will be demonstrated. Other settings are possible. The complete Navigation Map for the Display Modes is in Appendix A of this manual. The meter can also be configured with software (see *Communicator EXT 3.0 Manual*).

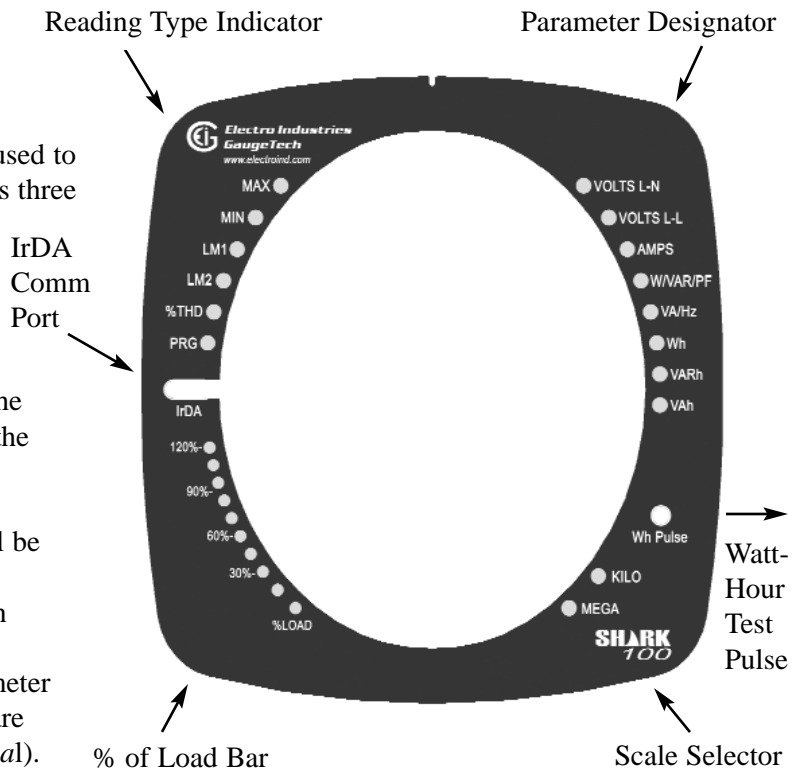

Figure 7.1: Shark Label

7.2: Start Up

- Upon Power Up, the meter will display a sequence of screens. The sequence includes the following screens:

- Lamp Test Screen where all LEDs are lighted
- Lamp Test Screen where all digits are lighted
- Firmware Screen showing build number
- Error Screen (if an error exists)

Shark 100 will then automatically Auto-Scroll the Parameter Designators on the right side of the front panel. Values are displayed for each parameter. The **KILO or MEGA LED** lights, showing the scale for the Wh, VARh and VAh readings. An example of a Wh reading is shown here.

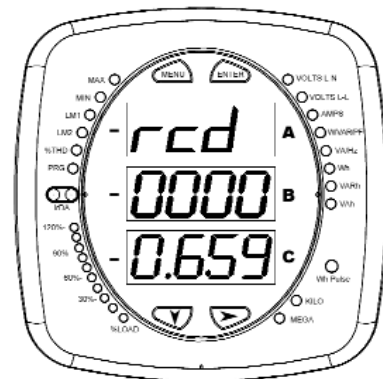

Figure 7.2: Wh Reading

- The Shark 100 will continue to scroll through the Parameter Designators, providing readings until one of the buttons on the front panel is pushed, causing the meter to enter one of the other MODES.

7.3: Configuration

7.3.1: Main Menu

- Push **MENU** from any of the Auto-Scrolling Readings. The MAIN MENU Screens appear. The String for **Reset Mode** (rSt) appears (blinking) in the A Screen. If you push **DOWN**, the MENU scrolls and the String for **Configuration Mode** (CFG) appears (blinking) in the A Screen. If you push **DOWN** again, the String for **Operating Mode** (OPr) appears (blinking) in the A Screen. If you push **DOWN** again, the MENU scrolls back to Reset Mode (rSt). If you push **ENTER** from the Main Menu, the meter enters the Mode that is in the A Screen and is blinking. See *Appendix A* for Navigation Map.

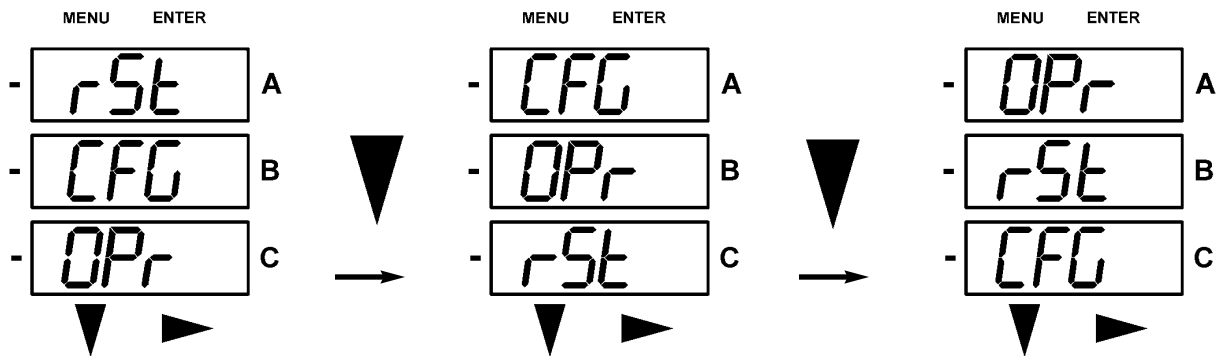

7.3.2: Reset Mode

- If you push **ENTER** from the Main Menu, the meter enters the Mode that is in the A Screen and is blinking. Reset Mode is the first mode to appear on the Main Menu. Push **ENTER** while (rSt) is in the A Screen and the “RESET ALL? no” screen appears. **Reset ALL** resets all Max and Min values. See *Appendix A* for Navigation Map.

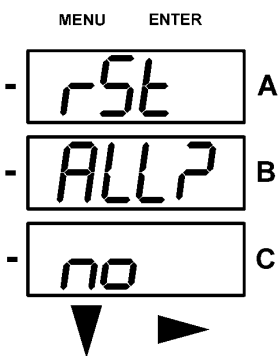

If you push **ENTER** again, the Main Menu continues to scroll. The DOWN button does not change the screen.

If you push the **RIGHT** button, the RESET All? YES screen appears.

To Reset All, you must enter a 4-digit Password, **if Enabled** in the software (see section 5.22).

Push **ENTER**; the following Password screen appears.

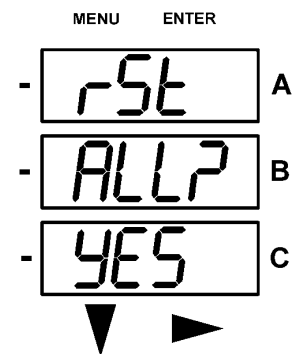

7.3.3: Configuration Mode

- The next Mode on the Main Menu is **Configuration Mode**. See *Appendix A* for Navigation Map.

To reach Configuration Mode, push the **MENU** Button from any of the Auto-Scrolling Readings, then push the **DOWN** button to reach the String for Configuration Mode (CFG).

Push **ENTER** and the Configuration Parameters scroll, starting at the “SCROLL, Ct, Pt” screen.

Push the **DOWN** Button to scroll all the parameters: Scroll, CT, PT, Connection (Cnct) and Port. The ‘Active’ parameter is in the A Screen and is flashing.

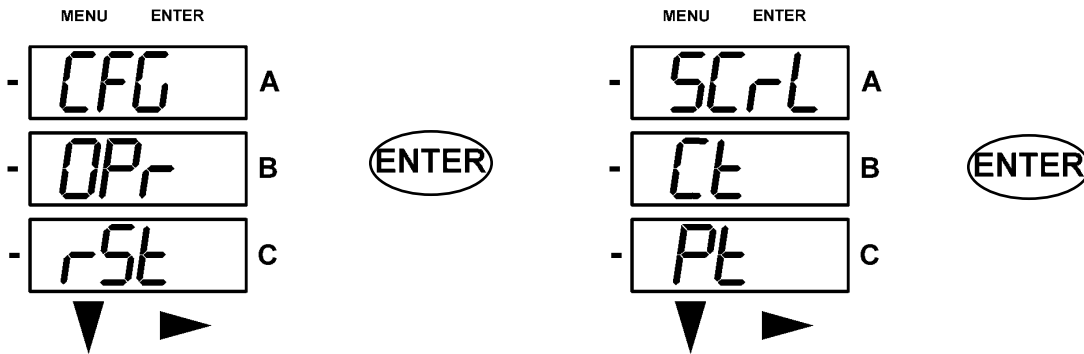

7.3.3.1: Configure Scroll Feature

Push **ENTER** and the **Scroll no** screen appears. Push **RIGHT** and changes to **Scroll YES**.

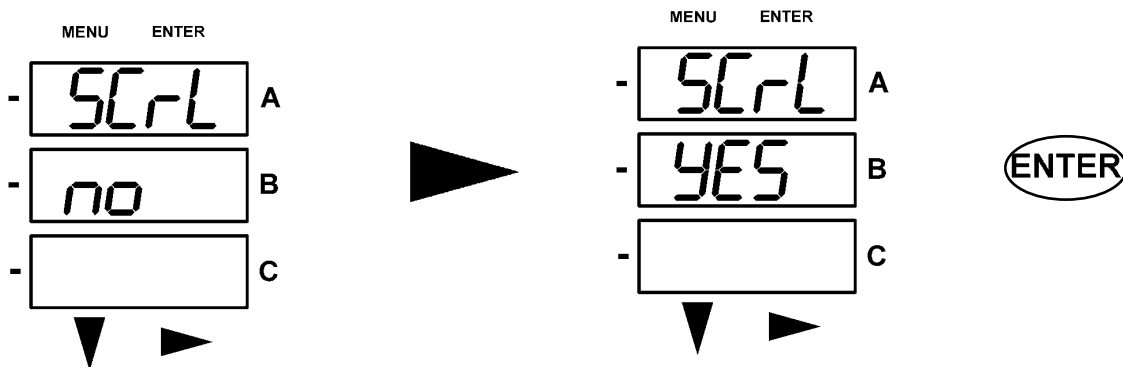

When in Scroll Mode, the unit scrolls each parameter for 7 seconds on and 1 second off. The meter can be configured through software to display only selected screens. If that is the case, it will only scroll the selected display. Additionally, the meter will only scroll the display enabled by the V-Switch that is installed.

Push **ENTER** (YES or no) and the screen scrolls to the Ct Parameters.

7.3.3.2: Program Configuration Mode Screens

■ To program the screens in Configuration Mode, other than SCROLL:

1. Push **DOWN** or **RIGHT** button (Example Ct-n screen below).
2. The Password screen appears, if Enabled (see section 5.22). Use the DOWN and RIGHT buttons to enter the PASSWORD. See section 7.3.2.1 for all Password steps.
Once the correct password is entered, push **ENTER**. The Ct-n screen reappears. The Program (PRG) LED flashes on the left side of the meter face.
The first digit of the setting will also flash.

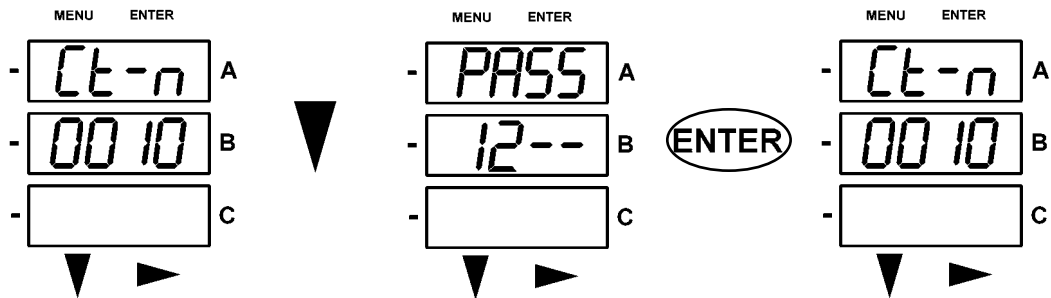

3. Use the **DOWN** button to change the digit.
Use the **RIGHT** Button to move to the next digit.
4. When the new setting is entered, push **MENU** twice.
The **STORE ALL** screen appears.

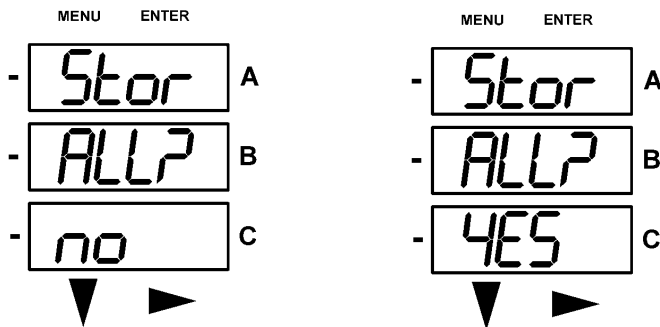

5. Use the **RIGHT** Button to scroll from **YES** to **no**.
6. While in **STORE ALL YES**, push **ENTER** to change the setting.

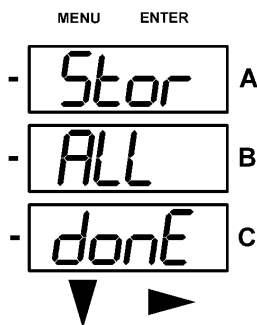

Store All Done appears.
Then, the meter RESETS.

7.3.3.3: Configure CT Setting

Push the **DOWN** Button to scroll all the parameters in Configuration Mode: Scroll, CT, PT, Connection (Cnct) and Port. The 'Active' parameter is in the A Screen and is flashing. Push **ENTER** when CT is the 'Active' parameter and the **Ct-n (Numerator)** screen appears. Push **ENTER** and the screen changes to **Ct-d (Denominator)**.

The **Ct-d** screen is **PRESET** to a **5 or 1 Amp** value at the factory and cannot be changed. **ENTER** again changes the screen to **Ct-S (Scaling)**. The Ct-S setting can be '1', '10' or '100'. To program these settings (except Ct-d), see section 7.3.3.2 above.

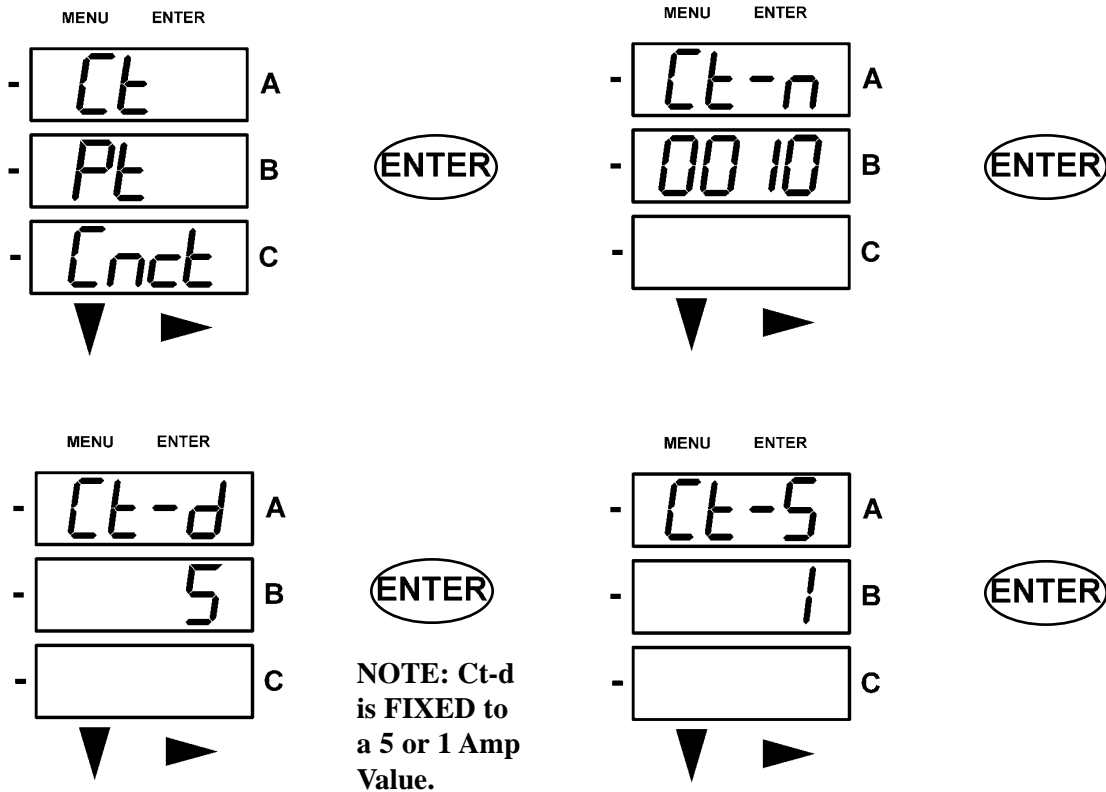

Example Settings:

- | | |
|-----------------------|--|
| 200/5 Amps: | Set the Ct-n value for 200 and the Ct-S value for 1. |
| 800/5 Amps: | Set the Ct-n value for 800 and the Ct-S value for 1. |
| 2,000/5 Amps: | Set the Ct-n value for 2000 and the Ct-S value for 1. |
| 10,000/5 Amps: | Set the Ct-n value for 1000 and the Ct-S value for 10. |

NOTE: The value for Amps is a product of the Ct-n value and the Ct-S value.

- Push **ENTER** and the screen scrolls through the other CFG parameters. Push **DOWN** or **RIGHT** and the Password screen appears (see section 7.3.2.1). Push **MENU** and you will return to the MAIN MENU.

NOTE: Ct-n and Ct-S are dictated by Primary Voltage. Ct-d is Secondary Voltage.

7.3.3.4: Configure PT Setting

Push the **DOWN** Button to scroll all the parameters in Configuration Mode: Scroll, CT, PT, Connection (Cnct) and Port. The ‘Active’ parameter is in the A Screen and is flashing.
 Push **ENTER** when PT is the ‘Active’ parameter and the **Pt-n (Numerator)** screen appears.
 Push **ENTER** and the screen changes to **Pt-d (Denominator)**.
ENTER again changes the screen to **Pt-S (Scaling)**. The Pt-S setting can be ‘1’, ‘10’ or ‘100’.
 To program any of these settings, see section 7.3.3.2 above.

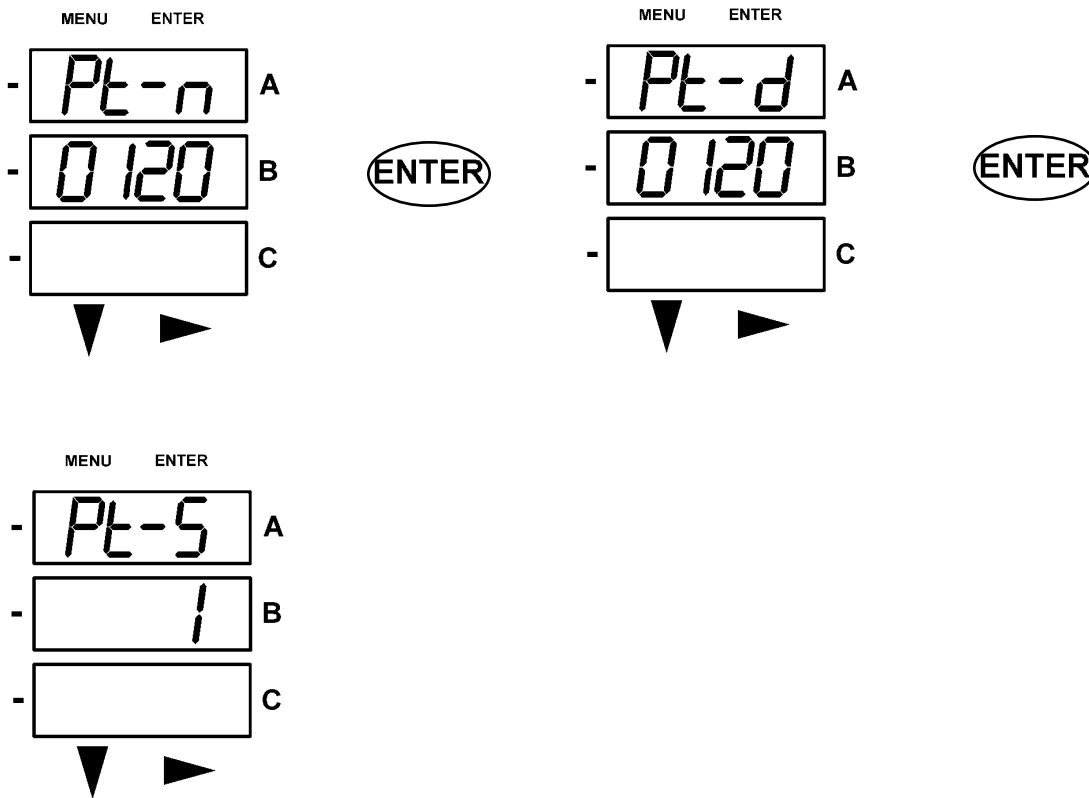

Example Settings:

277/277 Volts:	Pt-n value is 277, Pt-d value is 277, Pt-Multiplier is 1.
14,400/120 Volts:	Pt-n value is 1440, Pt-d value is 120, Pt-S value is 10.
138,000/69 Volts:	Pt-n value is 1380, Pt-d value is 69, Pt-S value is 100.
345,000/115 Volts:	Pt-n value is 3450, Pt-d value is 115, Pt-S value is 100.
345,000/69Volts:	Pt-n value is 345, Pt-d value is 69, Pt-S value is 1000.

- Push **ENTER** and the screen scrolls through the other CFG parameters.
 Push **DOWN** or **RIGHT** and the Password screen appears (see section 7.3.2.1).
 Push **MENU** and you will return to the MAIN MENU.

NOTE: Pt-n and Pt-S are dictated by Primary Voltage.
 Pt-d is Secondary Voltage.

7.3.3.5: Configure Connection (Cnct) Setting

Push the **DOWN** Button to scroll all the parameters in Configuration Mode: Scroll, CT, PT, Connection (Cnct) and Port. The 'Active' parameter is in the A Screen and is flashing.

Push **ENTER** when **Cnct** is the 'Active' parameter and the **Connection** screen appears for your meter. To change this setting, use the **RIGHT** button to scroll through the three settings. Select the setting that is right for your meter.

■ The possible Connection configurations include:

- 3 Element WYE
- 2.5 Element WYE
- 2 CT Delta

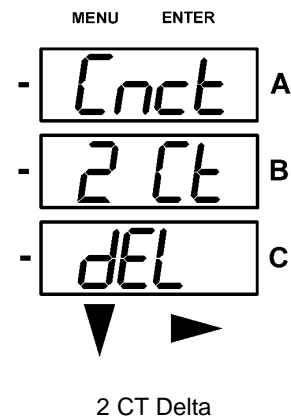
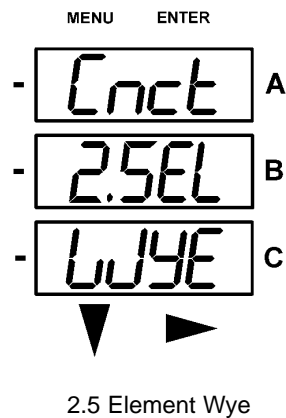
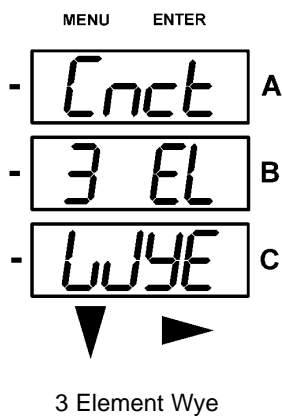

- Push **ENTER** and the screen scrolls through the other CFG parameters.
Push **DOWN** or **RIGHT** and the Password screen appears (see section 7.3.2.1).
Push **MENU** and you will return to the MAIN MENU.

7.3.3.6: Configure Communication Port Setting

Push the **DOWN** Button to scroll all the parameters in Configuration Mode: Scroll, CT, PT, Connection (Cnct) and Port. The ‘Active’ parameter is in the A Screen and is flashing.

Push **ENTER** when **PORT** is the ‘Active’ parameter and the **Port** screens appear for your meter.

- To program the PORT screens, see section 7.3.3.2.

- The possible PORT configurations include:
 - Address (Adr) (Three digit number)
 - BAUD (bAUd) 9600, 19,200, 38,400, 57,600
 - Protocol (Prot) DNP 3.0 (dnP)
 - Modbus (Mod) RTU (rtU)
 - Modbus (Mod) ASCII (ASCI)

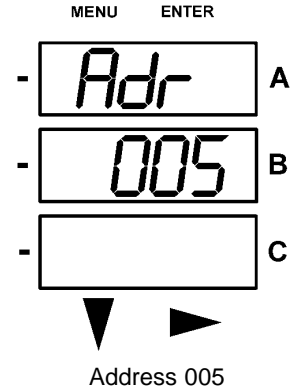

- The first PORT screen is **Address (Adr)**. The current Address appears on the screen. Follow the Programming steps in section 7.3.3.2 to change the Address.

- **Baud Rate (bAUd)** appears next. The current Baud Rate appears on the screen. To change the setting, follow the Programming steps in section 7.3.3.2. Possible screens appear below.

- **Protocol (Prot)** appears next. The current Protocol appears on the screen. To change the setting, follow the Programming steps in section 7.3.3.2. Possible screens appear below.

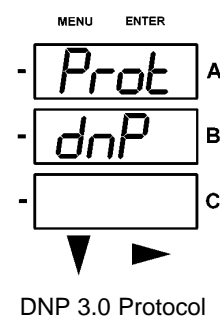
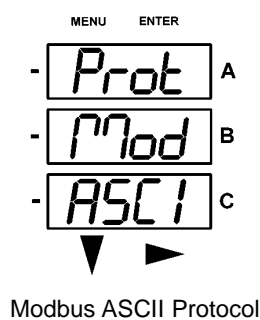
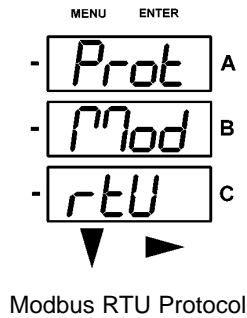
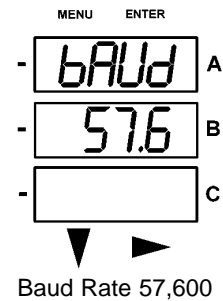
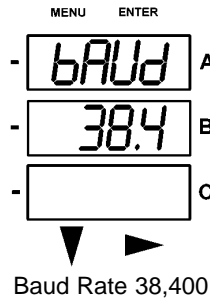
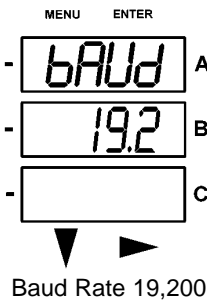
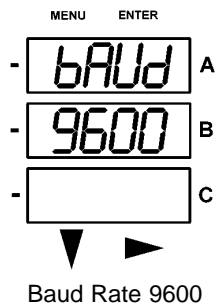

- Push **ENTER** and the screen scrolls through the other CFG parameters. Push **DOWN** or **RIGHT** and the Password screen appears (see section 7.3.2.1). Push **MENU** and you will return to the MAIN MENU.

7.3.4: Operating Mode

- Operating Mode is the Shark 100 meter’s Default Mode. After Start Up, the meter automatically scrolls through these parameter screens, if scrolling is enabled. The screen changes every 7 seconds. Scrolling is suspended for 3 minutes after any button is pressed.
- Push the **DOWN** Button to scroll all the parameters in Operating Mode.
 The ‘Active’ parameter has the Indicator light next to it on the right face of the meter..
 Push the **RIGHT** Button to view additional readings for that Parameter.
 A Table of the possible readings for Operating Mode is below.
 See *Appendix A (Sheet 2)* for the Operating Mode Navigation Map.

OPERATING MODE PARAMETER READINGS						
Parameter Designator Available by V-Switch	Possible Readings					V4 Only
VOLTS L-N V1-4	VOLTS_LN	VOLTS_LN_MAX	VOLTS_LN_MIN			VOLTS_LN_THD
VOLTS L-L V1-4	VOLTS_LL	VOLTS_LL_MAX	VOLTS_LL_MIN			
AMPS V1-4	AMPS	AMPS_NEUTRAL	AMPS_MAX	AMPS_MIN		AMPS_THD
W/VAR/PF V2-4	W_VAR_PF	W_VAR_PF_MAX_POS	W_VAR_PF_MIN_POS	W_VAR_PF_MAX_NEG	W_VAR_PF_MIN_NEG	
VA/Hz V2-4	VA_FREQ	VA_FREQ_MAX	VA_FREQ_MIN			
Wh V3-4	KWH_REC	KWH_DEL	KWH_NET	KWH_TOT		
VARh V3-4	KVARH_POS	KVARH_NEG	KVARH_NET	KVARH_TOT		
VAh V3-4	KVAH					

NOTE: Reading or Groups of readings are skipped if not applicable to the meter type or hookup, or if explicitly disabled in the programmable settings.

Appendix A

Shark Navigation Maps

A.1: Introduction

- The Shark 100 meter can be configured and a variety of functions performed using the BUTTONS on the meter face.

An Overview of the Elements and Buttons on the meter face can be found in Chapter 6.

An Overview of Programming using the BUTTONS can be found in Chapter 7.

The meter can also be programmed using software (see *Communicator EXT 3.0 Manual*).

A.2: Navigation Maps (Sheets 1 to 4)

- The Shark Navigation Maps begin on the next page.

They show in detail how to move from one screen to another and from one Display Mode to another using the buttons on the face of the meter. All Display Modes will automatically return to Operating Mode after 10 minutes with no user activity.

- **Shark Navigation Map Titles:**

Main Menu Screens (Sheet 1)

Operating Mode Screens (Sheet 2)

Reset Mode Screens (Sheet 3)

Configuration Mode Screens (Sheet 4)

Main Menu Screens (Sheet 1)

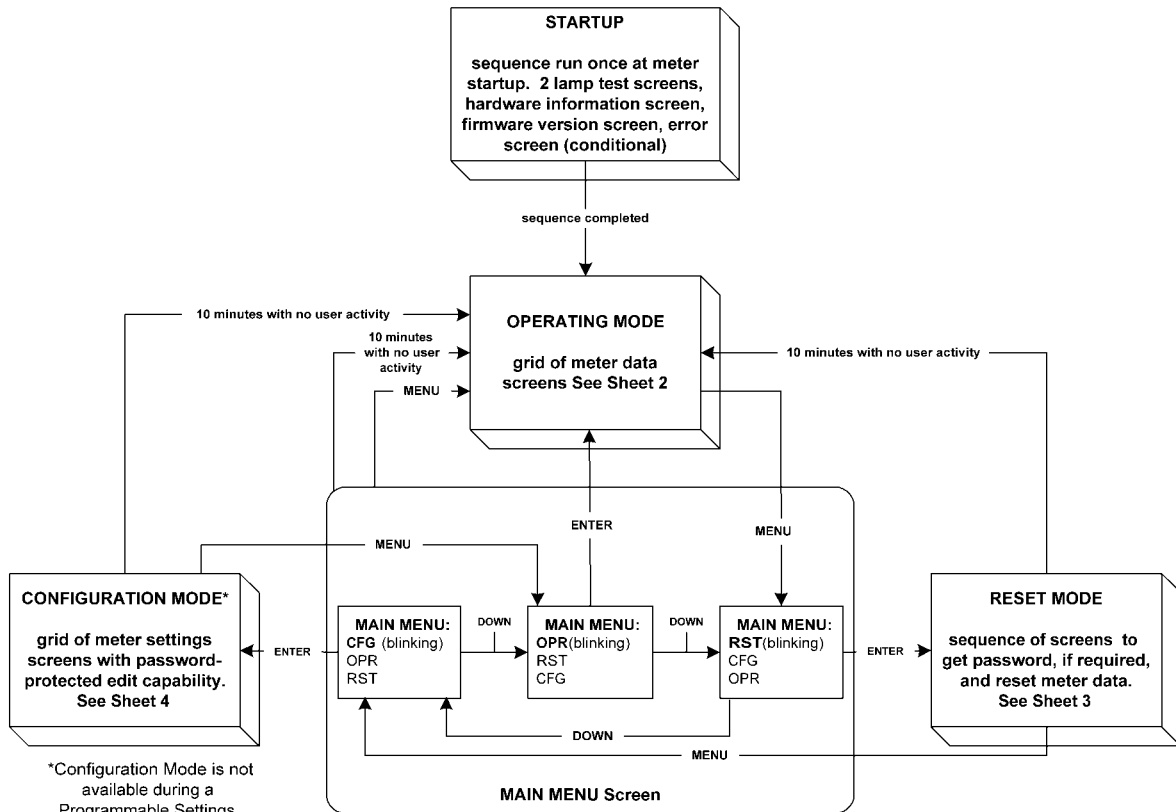

*Configuration Mode is not available during a Programmable Settings update via a COM Port.

MAIN MENU screen scrolls through 3 choices, showing all 3 at once. The top choice is always the "active" one, which is indicated by the blinking legend.

BUTTONS	
MENU	Returns to previous menu from any screen in any mode.
ENTER	Indicates acceptance of the current screen and advances to the next one.
DOWN, RIGHT	Navigation and Edit buttons
Navigation:	No digits or legends are blinking. On a menu, DOWN advances to the next menu selection, RIGHT does nothing. In a grid of screens, DOWN advances to the next row, RIGHT advances to the next column. Rows, columns and menus all navigate circularly.
Editing:	A digit or legend is blinking to indicate that it is eligible for change. When a digit is blinking, DOWN increases the digit value, RIGHT moves to the next digit. When a legend is blinking, either button advances to the next choice legend.

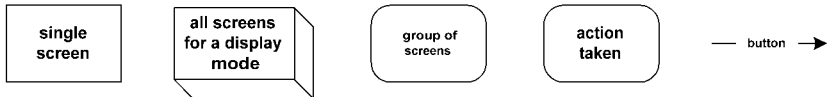

Operating Mode Screens (Sheet 2)

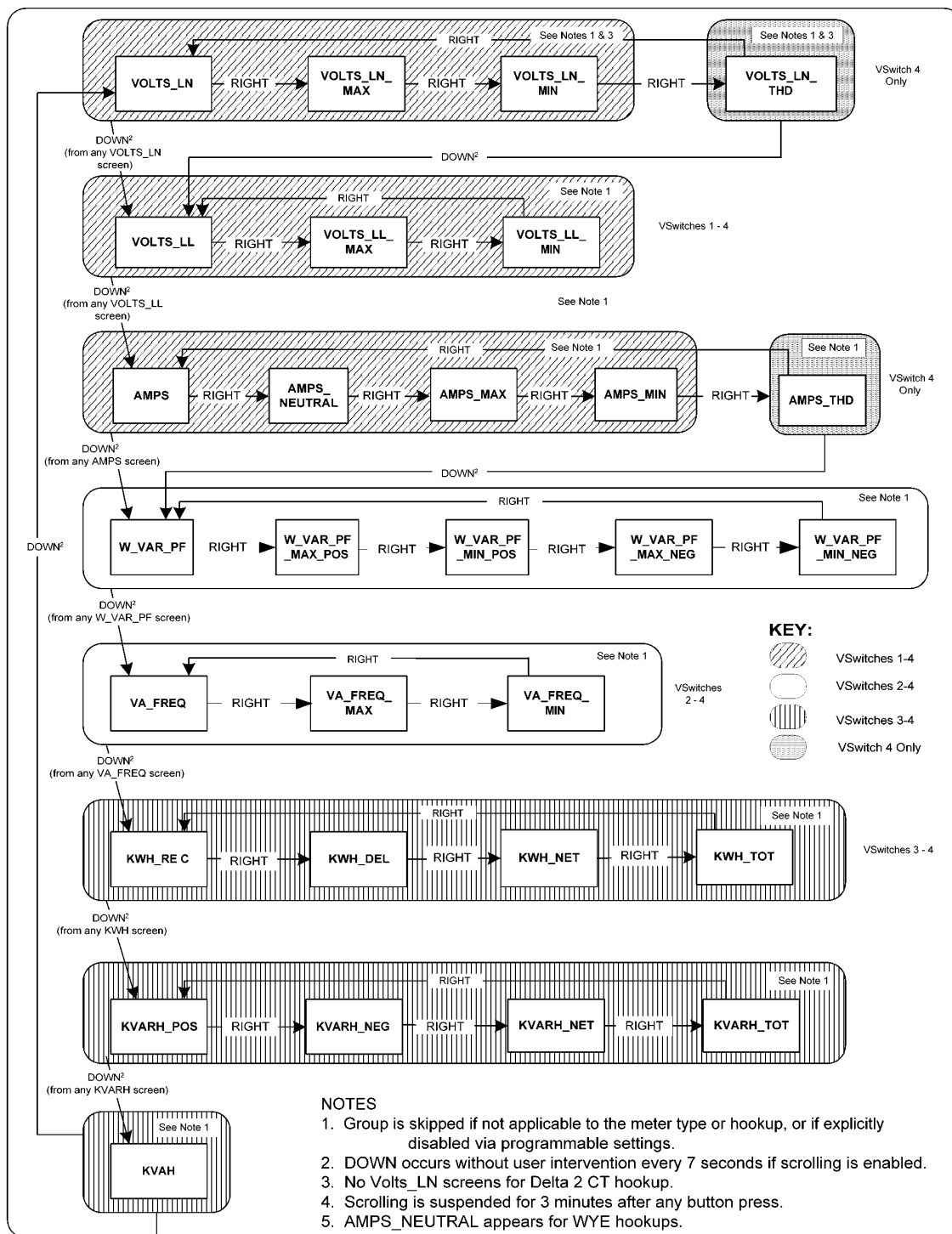

Reset Mode Screens (Sheet 3)

from MAIN MENU

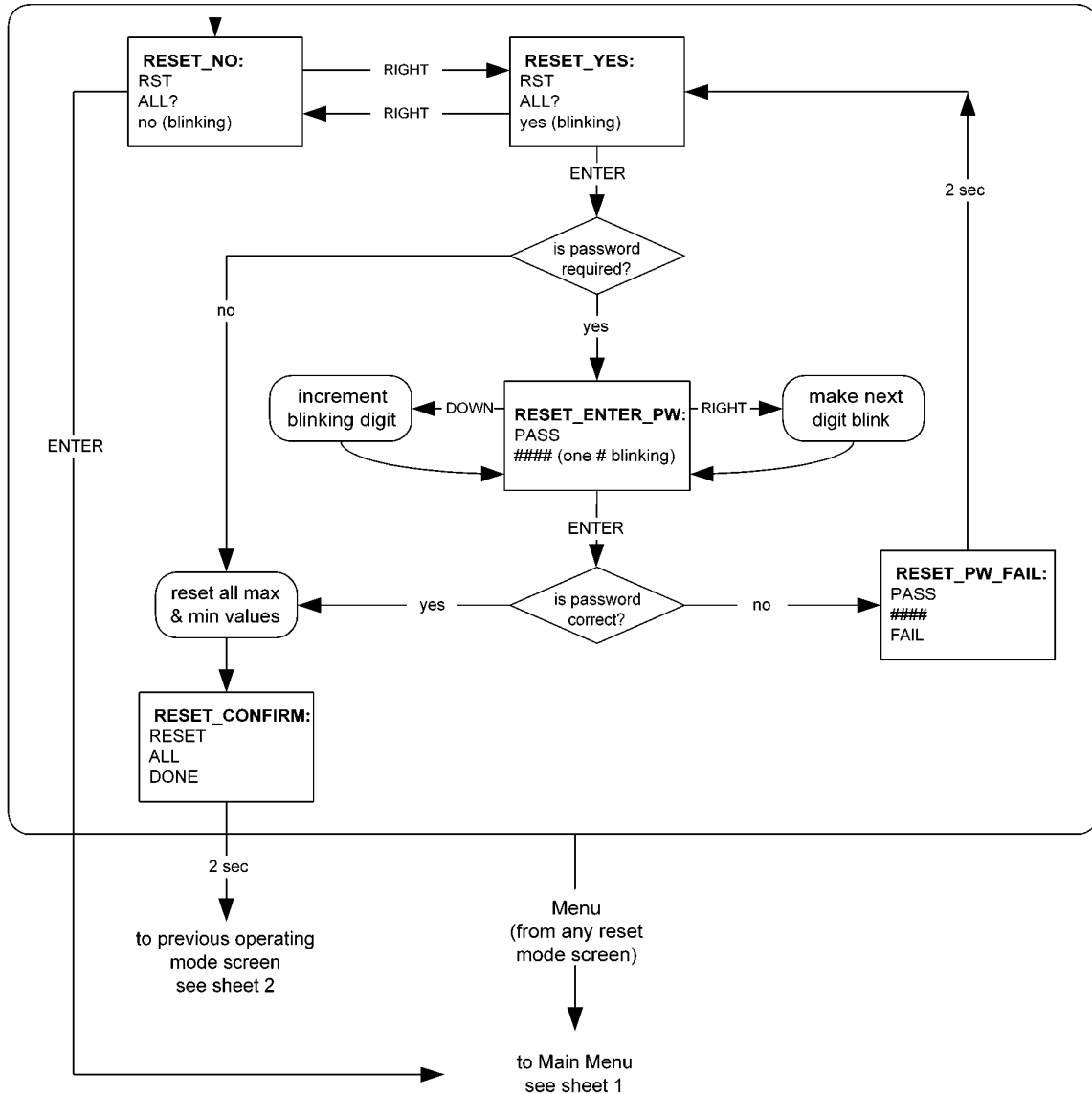

Configuration Mode Screens (Sheet 4)

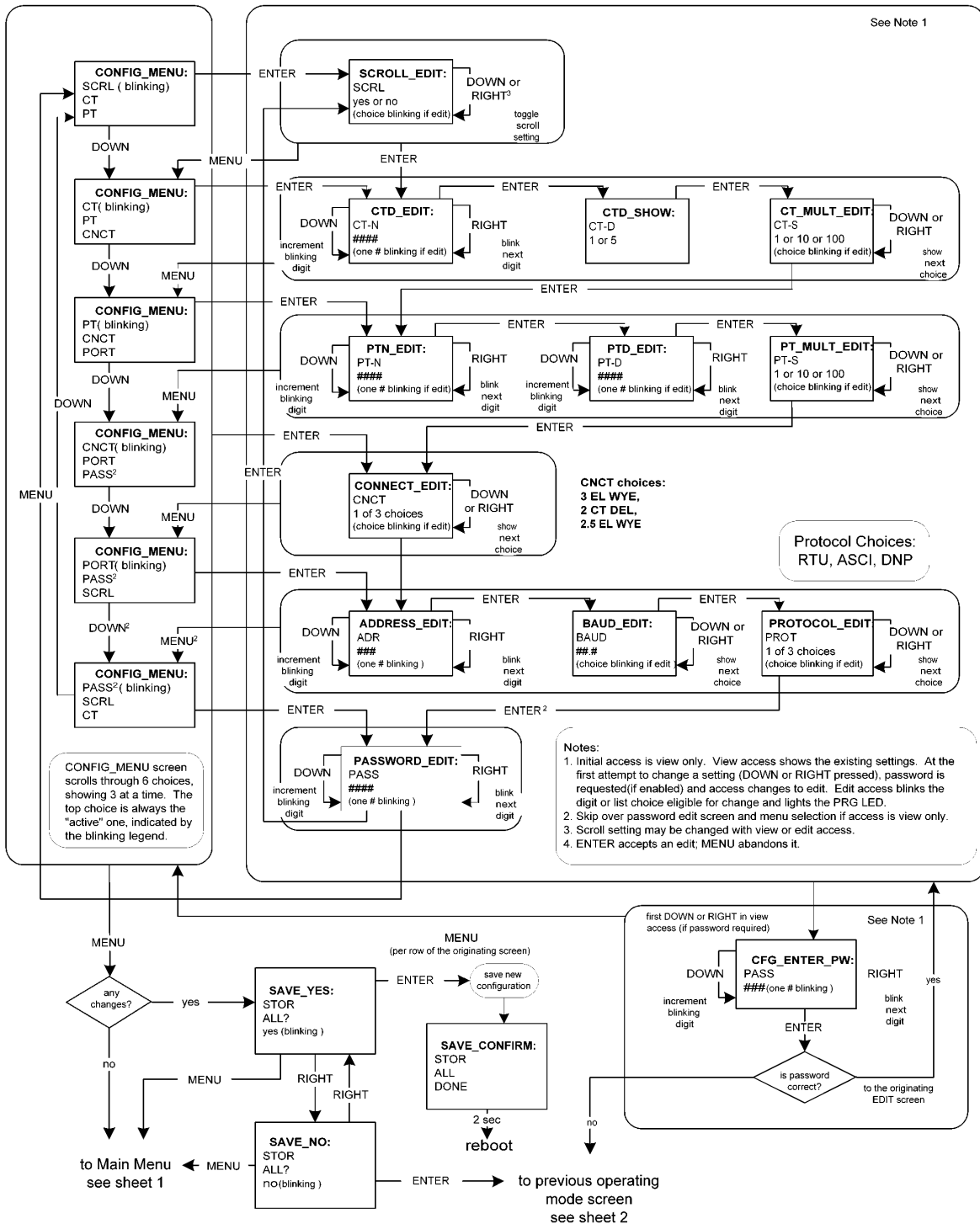

Appendix B

Modbus Mapping for Shark

B.1: Introduction

- The Modbus Map for the Shark 100 Meter gives details and information about the possible readings of the meter and about the programming of the meter. The Shark 100 can be programmed using the buttons on the face plate of the meter (Chapter 7). The meter can also be programmed using software. For a Programming Overview, see section 5.2 of this manual. For further details see the *Communicator EXT 3.0 Manual*.

B.2: Modbus Register Map Sections

- The Shark 100 Modbus Register Map includes the following sections:

Fixed Data Section, Registers 1- 47, details the Meter's Fixed Information described in Section 7.2.

Meter Data Section, Registers 1000 - 5003, details the Meter's Readings, including Primary Readings, Energy Block, Demand Block, Maximum and Minimum Blocks, THD Block, Phase Angle Block and Status Block. Operating Mode readings are described in Section 7.3.4.

Commands Section, Registers 20000 - 26011, details the Meter's Resets Block, Programming Block, Other Commands Block and Encryption Block.

Programmable Settings Section, Registers 30000 - 30067, details the Meter's Basic Setups.

Secondary Readings Section, Registers 40001 - 40100, details the Meter's Secondary Readings Setups.

B.3: Data Formats

- **ASCII:** ASCII characters packed 2 per register in high, low order and without any termination characters.
Example: "Shark 100" would be 4 registers containing 0x5378, 0x6172, 0x6B31, 0x3030.
- **SINT16/UINT16:** 16-bit signed/unsigned integer.
- **SINT32/UINT32:** 32-bit signed/unsigned integer spanning 2 registers. The lower-addressed register is the high order half.
- **FLOAT:** 32-bit IEEE floating point number spanning 2 registers. The lower-addressed register is the high order half (i.e., contains the exponent).

B.4: Floating Point Values

- Floating Point Values are represented in the following format:

Register	0																1															
Byte	0								1								0								1							
Bit	7	6	5	4	3	2	1	0	7	6	5	4	3	2	1	0	7	6	5	4	3	2	1	0	7	6	5	4	3	2	1	0
Meaning	s	e	e	e	e	e	e	e	e	m	m	m	m	m	m	m	m	m	m	m	m	m	m	m	m	m	m	m	m	m	m	m
	sign		exponent								mantissa																					

- The formula to interpret a Floating Point Value is: $-1^{sign} \times 2^{exponent-127} \times 1.mantissa = 0x0C4E11DB9$

$$-1^{sign} \times 2^{137-127} \times 1.11000010001110110111001$$

$$-1 \times 2^{10} \times 1.75871956$$

$$-1800.929$$

Register	0x0C4E1																0x01DB9															
Byte	0x0C4								0x0E1								0x01D								0x0B9							
Bit	7	6	5	4	3	2	1	0	7	6	5	4	3	2	1	0	7	6	5	4	3	2	1	0	7	6	5	4	3	2	1	0
	1	1	0	0	0	1	0	0	1	1	1	0	0	0	0	1	0	0	0	1	1	1	0	1	1	1	0	1	1	1	0	1
Meaning	s	e	e	e	e	e	e	e	e	m	m	m	m	m	m	m	m	m	m	m	m	m	m	m	m	m	m	m	m	m	m	m
	sign		exponent								mantissa																					
	1		0x089 = 137								0b011000010001110110111001																					

■ Formula Explanation

C4E11DB9 (hex) 11000100 11100001 00011101 10111001 (binary)

The sign of the mantissa (and therefore the number) is 1, which represents a negative value.

The Exponent is 10001001 (binary) or 137 decimal.

The Exponent is a value in excess 127. So, the Exponent value is 10.

The Mantissa is 11000010001110110111001 binary.

With the implied leading 1, the Mantissa is (1).C23B72 (hex).

The Floating Point Representation is therefore -1.75871956 times 2 to the 10.

Decimal equivalent: -1800.929

NOTE: Exponent = the whole number before the decimal point.
 Mantissa = the positive fraction after the decimal point.

B.5: Modbus Register Map (MM-1 to MM-8)

- The Shark 100 Modbus Register Map begins on the following page.

Modbus Address		Description ¹	Format	Range ⁶	Units or Resolution	Comments	# Reg
Hex	Decimal						
Fixed Data Section							
Identification Block read-only							
0000 - 0007	1 - 8	Meter Name	ASCII	16 char	none		8
0008 - 000F	9 - 16	Meter Serial Number	ASCII	16 char	none		8
0010 - 0010	17 - 17	Meter Type	UINT16	bit-mapped	-----t -----vvv	t = transducer model (1=yes, 0=no), vvv = V-switch(1 to 4)	1
0011 - 0012	18 - 19	Firmware Version	ASCII	4 char	none		2
0013 - 0013	20 - 20	Map Version	UINT16	0 to 65535	none		1
0014 - 0014	21 - 21	Meter Configuration	UINT16	bit-mapped	----- --fffff	fffff = calibration frequency (50 or 60)	1
0015 - 0015	22 - 22	ASIC Version	UINT16	0-65535	none		1
0016 - 0026	23 - 39	Reserved					17
0027 - 002E	40 - 47	GE Part Number	ASCII	16 char	none		8
						Block Size:	47
Meter Data Section²							
Primary Readings Block, 6 cycles (IEEE Floating Point) read-only							
0383 - 0384	900 - 901	Watts, 3-Ph total	FLOAT	-9999 M to +9999 M	watts		2
0385 - 0386	902 - 903	VARs, 3-Ph total	FLOAT	-9999 M to +9999 M	VARs		2
0387 - 0388	904 - 905	VA's, 3-Ph total	FLOAT	-9999 M to +9999 M	VA's		2
						Block Size:	6
Primary Readings Block, 60 cycles (IEEE Floating Point) read-only							
03E7 - 03E8	1000 - 1001	Volts A-N	FLOAT	0 to 9999 M	volts		2
03E9 - 03EA	1002 - 1003	Volts B-N	FLOAT	0 to 9999 M	volts		2
03EB - 03EC	1004 - 1005	Volts C-N	FLOAT	0 to 9999 M	volts		2
03ED - 03EE	1006 - 1007	Volts A-B	FLOAT	0 to 9999 M	volts		2
03EF - 03F0	1008 - 1009	Volts B-C	FLOAT	0 to 9999 M	volts		2
03F1 - 03F2	1010 - 1011	Volts C-A	FLOAT	0 to 9999 M	volts		2
03F3 - 03F4	1012 - 1013	Amps A	FLOAT	0 to 9999 M	amps		2
03F5 - 03F6	1014 - 1015	Amps B	FLOAT	0 to 9999 M	amps		2
03F7 - 03F8	1016 - 1017	Amps C	FLOAT	0 to 9999 M	amps		2
03F9 - 03FA	1018 - 1019	Watts, 3-Ph total	FLOAT	-9999 M to +9999 M	watts		2
03FB - 03FC	1020 - 1021	VARs, 3-Ph total	FLOAT	-9999 M to +9999 M	VARs		2
03FD - 03FE	1022 - 1023	VA's, 3-Ph total	FLOAT	-9999 M to +9999 M	VA's		2
03FF - 0400	1024 - 1025	Power Factor, 3-Ph total	FLOAT	-1.00 to +1.00	none		2
0401 - 0402	1026 - 1027	Frequency	FLOAT	0 to 65.00	Hz		2
0403 - 0404	1028 - 1029	Neutral Current	FLOAT	0 to 9999 M	amps		2
						Block Size:	30
Primary Energy Block read-only							

Modbus Address		Description ¹	Format	Range ⁶	Units or Resolution	Comments	# Reg
Hex	Decimal						
044B - 044C	1100 - 1101	W-hours, Received	SINT32	0 to 99999999 or 0 to -99999999	Wh per energy format	* Wh received & delivered always have opposite signs	2
044D - 044E	1102 - 1103	W-hours, Delivered	SINT32	0 to 99999999 or 0 to -99999999	Wh per energy format	* Wh received is positive for "view as load", delivered is positive for "view as generator"	2
044F - 0450	1104 - 1105	W-hours, Net	SINT32	-99999999 to 99999999	Wh per energy format		2
0451 - 0452	1106 - 1107	W-hours, Total	SINT32	0 to 99999999	Wh per energy format	* 5 to 8 digits	2
0453 - 0454	1108 - 1109	VAR-hours, Positive	SINT32	0 to 99999999	VARh per energy format	* decimal point implied, per energy format	2
0455 - 0456	1110 - 1111	VAR-hours, Negative	SINT32	0 to -99999999	VARh per energy format	* resolution of digit before decimal point =	2
0457 - 0458	1112 - 1113	VAR-hours, Net	SINT32	-99999999 to 99999999	VARh per energy format	units, kilo, or mega, per energy format	2
0459 - 045A	1114 - 1115	VAR-hours, Total	SINT32	0 to 99999999	VARh per energy format		2
045B - 045C	1116 - 1117	VA-hours, Total	SINT32	0 to 99999999	VAh per energy format	* see note 10	2
						Block Size:	18
Primary Demand Block (IEEE Floating Point)							read-only
07CF - 07D0	2000 - 2001	Amps A, Average	FLOAT	0 to 9999 M	amps		2
07D1 - 07D2	2002 - 2003	Amps B, Average	FLOAT	0 to 9999 M	amps		2
07D3 - 07D4	2004 - 2005	Amps C, Average	FLOAT	0 to 9999 M	amps		2
07D5 - 07D6	2006 - 2007	Positive Watts, 3-Ph, Average	FLOAT	-9999 M to +9999 M	watts		2
07D7 - 07D8	2008 - 2009	Positive VARs, 3-Ph, Average	FLOAT	-9999 M to +9999 M	VARs		2
07D9 - 07DA	2010 - 2011	Negative Watts, 3-Ph, Average	FLOAT	-9999 M to +9999 M	watts		2
07DB - 07DC	2012 - 2013	Negative VARs, 3-Ph, Average	FLOAT	-9999 M to +9999 M	VARs		2
07DD - 07DE	2014 - 2015	VAs, 3-Ph, Average	FLOAT	-9999 M to +9999 M	VAs		2
07DF - 07E0	2016 - 2017	Positive PF, 3-Ph, Average	FLOAT	-1.00 to +1.00	none		2
07E1 - 07E2	2018 - 2019	Negative PF, 3-PF, Average	FLOAT	-1.00 to +1.00	none		2
						Block Size:	20
Primary Minimum Block (IEEE Floating Point)							read-only
0BB7 - 0BB8	3000 - 3001	Volts A-N, Minimum	FLOAT	0 to 9999 M	volts		2
0BB9 - 0BBA	3002 - 3003	Volts B-N, Minimum	FLOAT	0 to 9999 M	volts		2
0BBB - 0BBC	3004 - 3005	Volts C-N, Minimum	FLOAT	0 to 9999 M	volts		2
0BBD - 0BBE	3006 - 3007	Volts A-B, Minimum	FLOAT	0 to 9999 M	volts		2
0BBF - 0BC0	3008 - 3009	Volts B-C, Minimum	FLOAT	0 to 9999 M	volts		2
0BC1 - 0BC2	3010 - 3011	Volts C-A, Minimum	FLOAT	0 to 9999 M	volts		2
0BC3 - 0BC4	3012 - 3013	Amps A, Minimum Avg Demand	FLOAT	0 to 9999 M	amps		2
0BC5 - 0BC6	3014 - 3015	Amps B, Minimum Avg Demand	FLOAT	0 to 9999 M	amps		2
0BC7 - 0BC8	3016 - 3017	Amps C, Minimum Avg Demand	FLOAT	0 to 9999 M	amps		2
0BC9 - 0BCA	3018 - 3019	Positive Watts, 3-Ph, Minimum Avg Demand	FLOAT	0 to +9999 M	watts		2
0BCB - 0BCC	3020 - 3021	Positive VARs, 3-Ph, Minimum Avg Demand	FLOAT	0 to +9999 M	VARs		2
0BCD - 0BCE	3022 - 3023	Negative Watts, 3-Ph, Minimum Avg Demand	FLOAT	0 to +9999 M	watts		2
0BCF - 0BD0	3024 - 3025	Negative VARs, 3-Ph, Minimum Avg Demand	FLOAT	0 to +9999 M	VARs		2
0BD1 - 0BD2	3026 - 3027	VAs, 3-Ph, Minimum Avg Demand	FLOAT	-9999 M to +9999 M	VAs		2
0BD3 - 0BD4	3028 - 3029	Positive Power Factor, 3-Ph, Minimum Avg Demand	FLOAT	-1.00 to +1.00	none		2

Modbus Address		Description ¹	Format	Range ⁶	Units or Resolution	Comments	# Reg
Hex	Decimal						
0BD5 - 0BD6	3030 - 3031	Negative Power Factor, 3-Ph, Minimum Avg Demand	FLOAT	-1.00 to +1.00	none		2
0BD7 - 0BD8	3032 - 3033	Frequency, Minimum	FLOAT	0 to 65.00	Hz		2
						Block Size:	34
Primary Maximum Block (IEEE Floating Point)						read-only	
0C1B - 0C1C	3100 - 3101	Volts A-N, Maximum	FLOAT	0 to 9999 M	volts		2
0C1D - 0C1E	3102 - 3103	Volts B-N, Maximum	FLOAT	0 to 9999 M	volts		2
0C1F - 0C20	3104 - 3105	Volts C-N, Maximum	FLOAT	0 to 9999 M	volts		2
0C21 - 0C22	3106 - 3107	Volts A-B, Maximum	FLOAT	0 to 9999 M	volts		2
0C23 - 0C24	3108 - 3109	Volts B-C, Maximum	FLOAT	0 to 9999 M	volts		2
0C25 - 0C26	3110 - 3111	Volts C-A, Maximum	FLOAT	0 to 9999 M	volts		2
0C27 - 0C28	3112 - 3113	Amps A, Maximum Avg Demand	FLOAT	0 to 9999 M	amps		2
0C29 - 0C2A	3114 - 3115	Amps B, Maximum Avg Demand	FLOAT	0 to 9999 M	amps		2
0C2B - 0C2C	3116 - 3117	Amps C, Maximum Avg Demand	FLOAT	0 to 9999 M	amps		2
0C2D - 0C2E	3118 - 3119	Positive Watts, 3-Ph, Maximum Avg Demand	FLOAT	0 to +9999 M	watts		2
0C2F - 0C30	3120 - 3121	Positive VARs, 3-Ph, Maximum Avg Demand	FLOAT	0 to +9999 M	VARs		2
0C31 - 0C32	3122 - 3123	Negative Watts, 3-Ph, Maximum Avg Demand	FLOAT	0 to +9999 M	watts		2
0C33 - 0C34	3124 - 3125	Negative VARs, 3-Ph, Maximum Avg Demand	FLOAT	0 to +9999 M	VARs		2
0C35 - 0C36	3126 - 3127	VAs, 3-Ph, Maximum Avg Demand	FLOAT	-9999 M to +9999 M	VAs		2
0C37 - 0C38	3128 - 3129	Positive Power Factor, 3-Ph, Maximum Avg Demand	FLOAT	-1.00 to +1.00	none		2
0C39 - 0C3A	3130 - 3131	Negative Power Factor, 3-Ph, Maximum Avg Demand	FLOAT	-1.00 to +1.00	none		2
0C3B - 0C3C	3132 - 3133	Frequency, Maximum	FLOAT	0 to 65.00	Hz		2
						Block Size:	34
THD Block ^{7, 13}						read-only	
0F9F - 0F9F	4000 - 4000	Volts A-N, %THD	UINT16	0 to 9999, or 65535	0.1%		1
0FA0 - 0FA0	4001 - 4001	Volts B-N, %THD	UINT16	0 to 9999, or 65535	0.1%		1
0FA1 - 0FA1	4002 - 4002	Volts C-N, %THD	UINT16	0 to 9999, or 65535	0.1%		1
0FA2 - 0FA2	4003 - 4003	Amps A, %THD	UINT16	0 to 9999, or 65535	0.1%		1
0FA3 - 0FA3	4004 - 4004	Amps B, %THD	UINT16	0 to 9999, or 65535	0.1%		1
0FA4 - 0FA4	4005 - 4005	Amps C, %THD	UINT16	0 to 9999, or 65535	0.1%		1
0FA5 - 0FA5	4006 - 4006	Phase A Current 0th harmonic magnitude	UINT16	0 to 65535	none		1
0FA6 - 0FA6	4007 - 4007	Phase A Current 1st harmonic magnitude	UINT16	0 to 65535	none		1
0FA7 - 0FA7	4008 - 4008	Phase A Current 2nd harmonic magnitude	UINT16	0 to 65535	none		1
0FA8 - 0FA8	4009 - 4009	Phase A Current 3rd harmonic magnitude	UINT16	0 to 65535	none		1
0FA9 - 0FA9	4010 - 4010	Phase A Current 4th harmonic magnitude	UINT16	0 to 65535	none		1
0FAA - 0FAA	4011 - 4011	Phase A Current 5th harmonic magnitude	UINT16	0 to 65535	none		1
0FAB - 0FAB	4012 - 4012	Phase A Current 6th harmonic magnitude	UINT16	0 to 65535	none		1
0FAC - 0FAC	4013 - 4013	Phase A Current 7th harmonic magnitude	UINT16	0 to 65535	none		1
0FAD - 0FAD	4014 - 4014	Phase A Voltage 0th harmonic magnitude	UINT16	0 to 65535	none		1
0FAE - 0FAE	4015 - 4015	Phase A Voltage 1st harmonic magnitude	UINT16	0 to 65535	none		1

Modbus Address		Description ¹	Format	Range ⁶	Units or Resolution	Comments	# Reg
Hex	Decimal						
0FAF - 0FAF	4016 - 4016	Phase A Voltage 2nd harmonic magnitude	UINT16	0 to 65535	none		1
0FB0 - 0FB0	4017 - 4017	Phase A Voltage 3rd harmonic magnitude	UINT16	0 to 65535	none		1
0FB1 - 0FB8	4018 - 4025	Phase B Current harmonic magnitude:			same as Phase A Current 0th to 7th harmonic magnitudes		8
0FB9 - 0FBC	4026 - 4029	Phase B Voltage harmonic magnitude			same as Phase A Voltage 0th to 3rd harmonic magnitudes		4
0FBD - 0FC4	4030 - 4037	Phase C Current harmonic magnitude:			same as Phase A Current 0th to 7th harmonic magnitudes		8
0FC5 - 0FC8	4038 - 4041	Phase C Voltage harmonic magnitude			same as Phase A Voltage 0th to 3rd harmonic magnitudes		4
						Block Size:	42
Phase Angle Block⁴						read-only	
1003 - 1003	4100 - 4100	Phase A Current	SINT16	-1800 to +1800	0.1 degree		1
1004 - 1004	4101 - 4101	Phase B Current	SINT16	-1800 to +1800	0.1 degree		1
1005 - 1005	4102 - 4102	Phase C Current	SINT16	-1800 to +1800	0.1 degree		1
1006 - 1006	4103 - 4103	Angle, Volts A-B	SINT16	-1800 to +1800	0.1 degree		1
1007 - 1007	4104 - 4104	Angle, Volts B-C	SINT16	-1800 to +1800	0.1 degree		1
1008 - 1008	4105 - 4105	Angle, Volts C-A	SINT16	-1800 to +1800	0.1 degree		1
						Block Size:	6
Status Block						read-only	
1387 - 1387	5000 - 5000	Meter Status	UINT16	bit-mapped	--expnch ssssssss	expnch = EEPROM block OK flags (e=energy, x=max, n=min, p=programmable settings, c=calibration, h=header), ssssssss = state (1=Run, 2=Limp, 10=Prog Set Update via buttons, 11=Prog Set Update via IrDA, 12=Prog Set Update via COM2)	1
1388 - 1388	5001 - 5001	Limits Status ⁷	UINT16	bit-mapped	87654321 87654321	high byte is setpt 1, 0=in, 1=out low byte is setpt 2, 0=in, 1=out	1
1389 - 138A	5002 - 5003	Time Since Reset	UINT32	0 to 4294967294	4 msec	wraps around after max coun	2
						Block Size:	4
Commands Section⁴							
Resets Block⁹						write-only	
4E1F - 4E1F	20000 - 20000	Reset Max/Min Blocks	UINT16	password ⁶			1
4E20 - 4E20	20001 - 20001	Reset Energy Accumulators	UINT16	password ⁶			1
						Block Size:	2
Meter Programming Block						read/conditional write	
55EF - 55EF	22000 - 22000	Initiate Programmable Settings Update	UINT16	password ⁶		meter enters PS update mode	1
55F0 - 55F0	22001 - 22001	Terminate Programmable Settings Update ³	UINT16	any value		meter leaves PS update mode via reset	1
55F1 - 55F1	22002 - 22002	Calculate Programmable Settings Checksum ³	UINT16			meter calculates checksum on RAM copy of PS block	1

Modbus Address		Description ¹	Format	Range ⁶	Units or Resolution	Comments	# Reg
Hex	Decimal						
55F2 - 55F2	22003 - 22003	Programmable Settings Checksum ²	UINT16			read/write checksum register; PS block saved in EEPROM on write ⁸	1
55F3 - 55F3	22004 - 22004	Write New Password ³	UINT16	0000 to 9999		write-only register; always reads zero	1
59D7 - 59D7	23000 - 23000	Initiate Meter Firmware Reprogramming	UINT16	password ⁵			1
						Block Size:	6
Other Commands Block						read/write	
61A7 - 61A7	25000 - 25000	Force Meter Restart	UINT16	password ⁵		causes a watchdog reset, always reads 0	1
						Block Size:	1
Encryption Block						read/write	
658F - 659A	26000 - 26011	Perform a Secure Operation	UINT16			encrypted command to read password or change meter type	12
						Block Size:	12
Programmable Settings Section							
Basic Setups Block						write only in PS update mode	
752F - 752F	30000 - 30000	CT multiplier & denominator	UINT16	bit-mapped	ddddddd mmmmmmm	high byte is denominator (1 or 5, read-only), low byte is multiplier (1, 10, or 100)	1
7530 - 7530	30001 - 30001	CT numerator	UINT16	1 to 9999	none		1
7531 - 7531	30002 - 30002	PT numerator	UINT16	1 to 9999	none		1
7532 - 7532	30003 - 30003	PT denominator	UINT16	1 to 9999	none		1
7533 - 7533	30004 - 30004	PT multiplier & hookup	UINT16	bit-mapped	mmmmmmmm MMMMhhhh	MMMMmmmmmmmm is PT multiplier (1, 10, 100, 1000), hhhh is hookup enumeration (0 = 3 element wye[9S], 1 = delta 2 CTs[5S], 3 = 2.5 element wye[6S])	1
7534 - 7534	30005 - 30005	Averaging Method	UINT16	bit-mapped	--iiiiii b----sss	iiiiii = interval (5,15,30,60) b = 0=block or 1=rolling sss = # subintervals (1,2,3,4)	1
7535 - 7535	30006 - 30006	Power & Energy Format	UINT16	bit-mapped	pppp--nn -eee-ddd	pppp = power scale (0=unit, 3=kilo, 6=mega, 8=auto) nn = number of energy digits (5-8 --> 0-3) eee = energy scale (0=unit, 3=kilo, 6=mega) ddd = energy digits after decimal point (0-6) See note 10.	1

Modbus Address		Description ¹	Format	Range ⁶	Units or Resolution	Comments	# Reg
Hex	Decimal						
7536 - 7536	30007 - 30007	Operating Mode Screen Enables	UINT16	bit-mapped	00000000 eeeeeeee	eeeeeeee = op mode screen rows on(1) or off(0), rows top to bottom are bits low order to high order	1
7537 - 753D	30008 - 30014	Reserved					7
753E - 753E	30015 - 30015	User Settings Flags	UINT16	bit-mapped	---g--nn srp--wf--	g = enable alternate full scale bargraph current (1=on, 0=off) nn = number of phases for voltage & current screens (3=ABC, 2=AB, 1=A, 0=ABC) s = scroll (1=on, 0=off) r = password for reset in use (1=on, 0=off) p = password for configuration in use (1=on, 0=off) w = pwr dir (0-view as load, 1-view as generator) f = flip power factor sign (1=yes, 0=no)	1
753F - 753F	30016 - 30016	Full Scale Current (for load % bargraph)	UINT16	0 to 9999	none	If non-zero and user settings bit g is set, this value replaces CT numerator in the full scale current calculation.	1
7540 - 7547	30017 - 30024	Meter Designation	ASCII	16 char	none		8
7548 - 7548	30025 - 30025	COM1 setup	UINT16	bit-mapped	----dddd -0100110	dddd = reply delay (* 50 msec) ppp = protocol (1-Modbus RTU, 2-Modbus ASCII, 3-DNP)	1
7549 - 7549	30026 - 30026	COM2 setup	UINT16	bit-mapped	----dddd -ppp-bbb	bbb = baud rate (1-9600, 2-19200, 4-38400, 6-57600)	1
754A - 754A	30027 - 30027	COM2 address	UINT16	1 to 247	none		1
754B - 754B	30028 - 30028	Limit #1 Identifier	UINT16	0 to 65535		use Modbus address as the identifier (see notes 7, 11, 12)	1
754C - 754C	30029 - 30029	Limit #1 Out High Setpoint	SINT16	-200.0 to +200.0	0.1% of full scale	Setpoint for the "above" limit (LM1), see notes 11-12.	1
754D - 754D	30030 - 30030	Limit #1 In High Threshold	SINT16	-200.0 to +200.0	0.1% of full scale	Threshold at which "above" limit clears; normally less than or equal to the "above" setpoint; see notes 11-12.	1
754E - 754E	30031 - 30031	Limit #1 Out Low Setpoint	SINT16	-200.0 to +200.0	0.1% of full scale	Setpoint for the "below" limit (LM2), see notes 11-12.	1
754F - 754F	30032 - 30032	Limit #1 In Low Threshold	SINT16	-200.0 to +200.0	0.1% of full scale	Threshold at which "below" limit clears; normally greater than or equal to the "below" setpoint; see notes 11-12.	1
7550 - 7554	30033 - 30037	Limit #2	SINT16	same as Limit #1	same as Limit #1	same as Limit #1	5
7555 - 7559	30038 - 30042	Limit #3	SINT16				5
755A - 755E	30043 - 30047	Limit #4	SINT16				5
755F - 7563	30048 - 30052	Limit #5	SINT16				5
7564 - 7568	30053 - 30057	Limit #6	SINT16				5

Modbus Address		Description ¹	Format	Range ⁶	Units or Resolution	Comments	# Reg
Hex	Decimal						
7569 - 756D	30058 - 30062	Limit #7	SINT16				5
756E - 7572	30063 - 30067	Limit #8	SINT16				5
						Block Size:	68
Secondary Readings Section							
Secondary Block						read-only except as noted	
9C40 - 9C40	40001 - 40001	System Sanity Indicator	UINT16	0 or 1	none	0 indicates proper meter operatio	1
9C41 - 9C41	40002 - 40002	Volts A-N	UINT16	2047 to 4095	volts	2047= 0, 4095= +150	1
9C42 - 9C42	40003 - 40003	Volts B-N	UINT16	2047 to 4095	volts	volts = 150 * (register - 2047) / 2047	1
9C43 - 9C43	40004 - 40004	Volts C-N	UINT16	2047 to 4095	volts		1
9C44 - 9C44	40005 - 40005	Amps A	UINT16	0 to 4095	amps	0= -10, 2047= 0, 4095= +10	1
9C45 - 9C45	40006 - 40006	Amps B	UINT16	0 to 4095	amps	amps = 10 * (register - 2047) / 2047	1
9C46 - 9C46	40007 - 40007	Amps C	UINT16	0 to 4095	amps		1
9C47 - 9C47	40008 - 40008	Watts, 3-Ph total	UINT16	0 to 4095	watts	0= -3000, 2047= 0, 4095= +3000	1
9C48 - 9C48	40009 - 40009	VARs, 3-Ph total	UINT16	0 to 4095	VARs	watts, VARs, VAs =	1
9C49 - 9C49	40010 - 40010	VAs, 3-Ph total	UINT16	2047 to 4095	VAs	3000 * (register - 2047) / 2047	1
9C4A - 9C4A	40011 - 40011	Power Factor, 3-Ph total	UINT16	1047 to 3047	none	1047= -1, 2047= 0, 3047= +1 pf = (register - 2047) / 1000	1
9C4B - 9C4B	40012 - 40012	Frequency	UINT16	0 to 2730	Hz	0= 45 or less, 2047= 60, 2730= 65 or more freq = 45 + ((register / 4095) * 30)	1
9C4C - 9C4C	40013 - 40013	Volts A-B	UINT16	2047 to 4095	volts	2047= 0, 4095= +300	1
9C4D - 9C4D	40014 - 40014	Volts B-C	UINT16	2047 to 4095	volts	volts = 300 * (register - 2047) / 2047	1
9C4E - 9C4E	40015 - 40015	Volts C-A	UINT16	2047 to 4095	volts		1
9C4F - 9C4F	40016 - 40016	CT numerator	UINT16	1 to 9999	none	CT = numerator * multiplier / denominator	1
9C50 - 9C50	40017 - 40017	CT multiplier	UINT16	1, 10, 100	none		1
9C51 - 9C51	40018 - 40018	CT denominator	UINT16	1 or 5	none	PT = numerator * multiplier / denominator	1
9C52 - 9C52	40019 - 40019	PT numerator	UINT16	1 to 9999	none		1
9C53 - 9C53	40020 - 40020	PT multiplier	UINT16	1, 10, 100	none	PT = numerator * multiplier / denominator	1
9C54 - 9C54	40021 - 40021	PT denominator	UINT16	1 to 9999	none		1
9C55 - 9C56	40022 - 40023	W-hours, Positive	UINT32	0 to 99999999	Wh per energy format	* 5 to 8 digits	2
9C57 - 9C58	40024 - 40025	W-hours, Negative	UINT32	0 to 99999999	Wh per energy format		2
9C59 - 9C5A	40026 - 40027	VAR-hours, Positive	UINT32	0 to 99999999	VARh per energy format	* resolution of digit before decimal point = units, kilo, or mega, per energy format	2
9C5B - 9C5C	40028 - 40029	VAR-hours, Negative	UINT32	0 to 99999999	VARh per energy format		2
9C5D - 9C5E	40030 - 40031	VA-hours	UINT32	0 to 99999999	VAh per energy format	* see note 10	2
9C5F - 9C5F	40032 - 40032	Neutral Current	UINT16	0 to 4095	amps	see Amps A/B/C above	1
9C60 - 9CA2	40033 - 40099	Reserved	N/A	N/A	none		67
9CA3 - 9CA3	40100 - 40100	Reset Energy Accumulators	UINT16	password ⁵		write-only register; always reads as 0	1
						Block Size:	100

Modbus Address		Description ¹	Format	Range ⁶	Units or Resolution	Comments	# Reg
Hex	Decimal						
End of Map							

Data Formats

ASCII	ASCII characters packed 2 per register in high, low order and without any termination characters. For example, "Shark100" would be 4 registers containing 0x5378, 0x6172, 0x6B31, 0x3030.
SINT16 / UINT16	16-bit signed / unsigned integer.
SINT32 / UINT32	32-bit signed / unsigned integer spanning 2 registers. The lower-addressed register is the high order half.
FLOAT	32-bit IEEE floating point number spanning 2 registers. The lower-addressed register is the high order half (i.e., contains the exponent).

Notes

- 1 All registers not explicitly listed in the table read as 0. Writes to these registers will be accepted but won't actually change the register (since it doesn't exist).
- 2 Meter Data Section items read as 0 until first readings are available or if the meter is not in operating mode. Writes to these registers will be accepted but won't actually change the register.
- 3 Register valid only in programmable settings update mode. In other modes these registers read as 0 and return an illegal data address exception if a write is attempted.
- 4 Meter command registers always read as 0. They may be written only when the meter is in a suitable mode. The registers return an illegal data address exception if a write is attempted in an incorrect mode.
- 5 If the password is incorrect, a valid response is returned but the command is not executed. Use 5555 for the password if passwords are disabled in the programmable settings.
- 6 M denotes a 1,000,000 multiplier.
- 7 Not applicable to Shark 100, V-Switch 1, 2, or 3
- 8 Writing this register causes data to be saved permanently in EEPROM. If there is an error while saving, a slave device failure exception is returned and programmable settings mode automatically terminates via reset.
- 9 Reset commands make no sense if the meter state is LIMP. An illegal function exception will be returned.
- 10 Energy registers should be reset after a format change.
- 11 Entities to be monitored against limits are identified by Modbus address. Entities occupying multiple Modbus registers, such as floating point values, are identified by the lower register address. If any of the 8 limits is unused, set its identifier to zero. If the indicated Modbus register is not used or is a non-sensical entity for limits, it will behave as an unused I
- 12 There are 2 setpoints per limit, one above and one below the expected range of values. LM1 is the "too high" limit, LM2 is "too low". The entity goes "out of limit" on LM1 when its value is greater than the setpoint. It remains "out of limit" until the value drops below the in threshold. LM2 works similarly, in the opposite direction. If limits in only one direction are of interest, set the in threshold on the "wrong" side of the setpoint. Limits are specified as % of full scale, where full scale is automatically set appropriately for the entity being monitored:
 - current FS = CT numerator * CT multiplier
 - voltage FS = PT numerator * PT multiplier
 - power FS = CT numerator * CT multiplier * PT numerator * PT multiplier * 3 [* SQRT(3) for delta hooku
 - frequency FS = 60 (or 50)
 - power factor FS = 1.0
 - percentage FS = 100.0
 - angle FS = 180.0
- 13 THD not available shows 65535 (=0xFFFF) in all THD and harmonic magnitude registers for the channel when V-switch=4. THD may be unavailable due to low V or I amplitude, or delta hookup (V only).
- 14 All 3 voltage angles are measured for Wye and Delta hookups. For 2.5 Element, Vac is measured and Vab & Vbc are calculated. If a voltage phase is missing, the two voltage angles in which it participates are set to zero. A and C phase current angles are measured for all hookups. B phase current angle is measured for Wye and is zero for other hookups. If a voltage phase is missing, its current angle is zero.

Appendix C

DNP Mapping for Shark

C.1: Introduction

- The DNP Map for the Shark 100 Meter shows the client-server relationship in the Shark's use of DNP Protocol.

C.2: DNP Mapping (DNP-1 to DNP-2)

- The Shark 100 DNP Point Map follows.

Binary Output States, Control Relay Outputs, Binary Counters (Primary) and Analog Inputs are described on Page 1.

Internal Indication is described on Page 2.

Object	Point	Var	Description	Format	Range	Multiplier	Units	Comments
Binary Output States								Read via Class 0 only
10	0	2	Reset Energy Counters	BYTE	Always 1	N/A	none	
10	1	2	Change to Modbus RTU Protocol	BYTE	Always 1	N/A	none	
Control Relay Outputs								
12	0	1	Reset Energy Counters	N/A	N/A	N/A	none	Responds to Function 5 (Direct Operate), Qualifier Code 17x or 28x, Control Code 3, Count 0, On 0 msec, Off 1 msec ONLY.
12	1	1	Change to Modbus RTU Protocol	N/A	N/A	N/A	none	Responds to Function 6 (Direct Operate - No Ack), Qualifier Code 17x, Control Code 3, Count 0, On 0 msec, Off 1 msec ONLY.
Binary Counters (Primary)								Read via Class 0 only
20	0	4	W-hours, Positive	UINT32	0 to 99999999	multiplier = $10^{(n-d)}$, where n and d are derived from the energy format. n = 0, 3, or 6 per energy format scale and d = number of decimal places.	W hr	example: energy format = 7.2K and W-hours counter = 1234567 n=3 (K scale), d=2 (2 digits after decimal point), multiplier = $10^{(3-2)} = 10^1 = 10$, so energy is 1234567 * 10 Whrs, or 12345.67 KWhrs
20	1	4	W-hours, Negative	UINT32	0 to 99999999		W hr	
20	2	4	VAR-hours, Positive	UINT32	0 to 99999999		VAR hr	
20	3	4	VAR-hours, Negative	UINT32	0 to 99999999		VAR hr	
20	4	4	VA-hours, Total	UINT32	0 to 99999999		VA hr	
Analog Inputs (Secondary)								Read via Class 0 only
30	0	5	Meter Health	SINT16	0 or 1	N/A	none	0 = OK
30	1	5	Volts A-N	SINT16	0 to 32767	(150 / 32768)	V	Values above 150V secondary read 32767.
30	2	5	Volts B-N	SINT16	0 to 32767	(150 / 32768)	V	
30	3	5	Volts C-N	SINT16	0 to 32767	(150 / 32768)	V	
30	4	5	Volts A-B	SINT16	0 to 32767	(300 / 32768)	V	Values above 300V secondary read 32767.
30	5	5	Volts B-C	SINT16	0 to 32767	(300 / 32768)	V	
30	6	5	Volts C-A	SINT16	0 to 32767	(300 / 32768)	V	
30	7	5	Amps A	SINT16	0 to 32767	(10 / 32768)	A	Values above 10A secondary read 32767.
30	8	5	Amps B	SINT16	0 to 32767	(10 / 32768)	A	
30	9	5	Amps C	SINT16	0 to 32767	(10 / 32768)	A	

Object	Point	Var	Description	Format	Range	Multiplier	Units	Comments
30	10	5	Watts, 3-Ph total	SINT16	-32768 to +32767	(4500 / 32768)	W	
30	11	5	VARs, 3-Ph total	SINT16	-32768 to +32767	(4500 / 32768)	VAR	
30	12	5	VAs, 3-Ph total	SINT16	0 to +32767	(4500 / 32768)	VA	
30	13	5	Power Factor, 3-Ph total	SINT16	-1000 to +1000	0.001	none	
30	14	5	Frequency	SINT16	0 to 9999	0.01	Hz	
30	15	5	Positive Watts, 3-Ph, Maximum Avg Demand	SINT16	-32768 to +32767	(4500 / 32768)	W	
30	16	5	Positive VARs, 3-Ph, Maximum Avg Demand	SINT16	-32768 to +32767	(4500 / 32768)	VAR	
30	17	5	Negative Watts, 3-Ph, Maximum Avg Demand	SINT16	-32768 to +32767	(4500 / 32768)	W	
30	18	5	Negative VARs, 3-Ph, Maximum Avg Demand	SINT16	-32768 to +32767	(4500 / 32768)	VAR	
30	19	5	VAs, 3-Ph, Maximum Avg Demand	SINT16	-32768 to +32767	(4500 / 32768)	VA	
30	20	5	Angle, Phase A Current	SINT16	-1800 to +1800	0.1	degree	
30	21	5	Angle, Phase B Current	SINT16	-1800 to +1800	0.1	degree	
30	22	5	Angle, Phase C Current	SINT16	-1800 to +1800	0.1	degree	
30	23	5	Angle, Volts A-B	SINT16	-1800 to +1800	0.1	degree	
30	24	5	Angle, Volts B-C	SINT16	-1800 to +1800	0.1	degree	
30	25	5	Angle, Volts C-A	SINT16	-1800 to +1800	0.1	degree	
30	26	5	CT numerator	SINT16	1 to 9999	N/A	none	CT ratio = (numerator * multiplier) / denominator
30	27	5	CT multiplier	SINT16	1, 10, or 100	N/A	none	
30	28	5	CT denominator	SINT16	1 or 5	N/A	none	
30	29	5	PT numerator	SINT16	1 to 9999	N/A	none	PT ratio = (numerator * multiplier) / denominator
30	30	5	PT multiplier	SINT16	1, 10, or 100	N/A	none	
30	31	5	PT denominator	SINT16	1 to 9999	N/A	none	
30	32	5	Neutral Current	SINT16	0 to 32767	(10 / 32768)	A	For 1A model, multiplier is (2 / 32768) and values above 2A secondary read 32767.
Internal Indication								
80	0	1	Device Restart Bit	N/A	N/A	N/A	none	Clear via Function 2 (Write), Qualifier Code 0.

Appendix D

DNP 3.0 Protocol Assignments for Shark

D.1: DNP Implementation

■ PHYSICAL LAYER

The Shark 100 meter is capable of using RS-485 as the physical layer. This is accomplished by connecting a PC to the Shark with the RS-485 connection on the back face of the meter.

■ RS-485

RS-485 provides multi-drop network communication capabilities. Multiple meters may be placed on the same bus, allowing for a Master device to communicate with any of the other devices. Appropriate network configuration and termination should be evaluated for each installation to insure optimal performance.

■ Communication Parameters

Shark 100 meters communicate in DNP 3.0 using the following communication settings:

- 8 Data Bits
- No Parity
- 1 Stop Bit

■ Baud Rates

Shark 100 meters are programmable to use several standard baud rates, including:

- 9600 Baud
- 19200 Baud
- 38400 Baud
- 57600 Baud

D.2: Data Link Layer

- The Data Link Layer as implemented on Shark meters is subject to the following considerations:

■ Control Field

The Control Byte contains several bits and a Function Code. Specific notes follow.

Control Bits

Communication directed to the meter should be Primary Master messages (DIR = 1, PRM = 1). Response will be primary Non-Master messages (DIR = 0, PRM = 1). Acknowledgment will be Secondary Non-Master messages (DIR = 0, PRM = 0).

■ Function Codes

Shark meters support all of the Function Codes for DNP 3.0. Specific notes follow.

Reset of Data Link (Function 0)

Before confirmed communication with a master device, the Data Link Layer must be reset. This is necessary after a meter has been restarted, either by applying power to the meter or reprogramming the meter. The meter must receive a RESET command before confirmed communication may take

place. Unconfirmed communication is always possible and does not require a RESET.

User Data (Function 3)

After receiving a request for USER DATA, the meter will generate a Data Link CONFIRMATION, signaling the reception of that request, before the actual request is processed. If a response is required, it will also be sent as UNCONFIRMED USER DATA.

Unconfirmed User Data (Function 4)

After receiving a request for UNCONFIRMED USER DATA, if a response is required, it will be sent as UNCONFIRMED USER DATA.

Address

DNP 3.0 allows for addresses from 0 - 65534 (0x0000 - 0xFFFFE) for individual device identification, with the address 65535 (0xFFFF) defined as an all stations address. Shark meters' addresses are programmable from 0 - 247 (0x0000 - 0x00F7), and will recognize address 65535 (0xFFFF) as the all stations address.

D.3: Transport Layer

The Transport Layer as implemented on Shark meters is subject to the following considerations:

Transport Header

Multiple-frame messages are not allowed for Shark meters. Each Transport Header should indicate it is both the first frame (FIR = 1) as well as the final frame (FIN = 1).

D.4: Application Layer

The Application Layer contains a header (Request or Response Header, depending on direction) and data. Specific notes follow.

■ **Application Headers**

Application Headers contain the Application Control Field and the Function Code.

■ **Application Control Field**

Multiple-fragment messages are not allowed for Shark meters. Each Application Header should indicate it is both the first fragment (FIR = 1) as well as the final fragment (FIN = 1). Application-Level confirmation is not used for Shark meters.

■ **Function Codes**

The following Function codes are implemented on Shark meters.

Read (Function 1)

Objects supporting the READ function are:

- Binary Outputs (Object 10)
- Counters (Object 20)
- Analog Inputs (Object 30)
- Class (Object 60)

These Objects may be read either by requesting a specific Variation available as listed in this document, or by requesting Variation 0. READ request for Variation 0 of an Object will be fulfilled with the Variation listed in this document.

Write (Function 2)

Objects supporting the WRITE function are:

- Internal Indications (Object 80)

Direct Operate (Function 5)

Objects supporting the DIRECT OPERATE function are:

- Control Relay Output Block (Object 12)

Direct Operate - No Acknowledgment (Function 6)

Objects supporting the DIRECT OPERATE - NO ACKNOWLEDGMENT function are:

- Change to MODBUS RTU Protocol

Response (Function 129)

Application responses from Shark meters use the RESPONSE function.

■ **Application Data**

Application Data contains information about the Object and Variation, as well as the Qualifier and Range.

D.4.1: Object and Variation

The following Objects and Variations are supported on Shark meters:

- Binary Output Status (Object 10, Variation 2) †
- Control Relay Output Block (Object 12, Variation 1)
- 32-Bit Binary Counter Without Flag (Object 20, Variation 5) †
- 16-Bit Analog Input Without Flag (Object 30, Variation 4) †
- Class 0 Data (Object 60, Variation 1) †
- Internal Indications (Object 80, Variation 1)

† READ requests for Variation 0 will be honored with the above Variations.

D.4.1.1: Binary Output Status (Obj. 10, Var. 2)

Binary Output Status supports the following functions:

Read (Function 1)

A READ request for Variation 0 will be responded to with Variation 2.

Binary Output Status is used to communicate the following data measured by Shark meters:

■ Energy Reset State

Change to MODBUS RTU Protocol State

Energy Reset State (Point 0)

Shark meters accumulate power generated or consumed over time as Hour Readings, which measure positive VA Hours and positive and negative W Hours and VAR Hours. These readings may be reset using a Control Relay Output Block object (Obj. 12). This Binary Output Status point reports whether the Energy Readings are in the process of being reset, or if they are accumulating. Normally, readings are being accumulated and the state of this point is read as '0'. If the readings are in the process of being reset, the state of this point is read as '1'.

Change to Modbus RTU Protocol State (Point 1)

Shark meters are capable of changing from DNP Protocol to Modbus RTU Protocol. This enables the user to update the Device Profile of the meter. This does not change the Protocol setting. A meter reset brings you back to DNP. Status reading of "1" equals Open, or de-energized. A reading of "0" equals Closed, or energized.

D.4.1.2: Control Relay Output Block (Obj. 12, Var. 1)

Control Relay Output Block supports the following functions:

Direct Operate (Function 5)

Direct Operate - No Acknowledgment (Function 6)

Control Relay Output Blocks are used for the following purposes:

■ Energy Reset

Change to MODBUS RTU Protocol

Energy Reset (Point 0)

Shark meters accumulate power generated or consumed over time as Hour Readings, which measure positive VA Hours and positive and negative W Hours and VAR Hours. These readings may be reset using Point 0.

Use of the DIRECT OPERATE (Function 5) function will operate only with the settings of Pulsed ON (Code = 1 of Control Code Field) once (Count = 0x01) for ON 1 millisecond and OFF 0 milliseconds.

- **Change to Modbus RTU Protocol (Point 1)**
Shark meters are capable of changing from DNP Protocol to Modbus RTU Protocol. This enables the user to update the Device Profile of the meter. This does not change the Protocol setting. A meter reset brings you back to DNP.

Use of the DIRECT OPERATE - NO ACKNOWLEDGE (Function 6) function will operate only with the settings of Pulsed ON (Code = 1 of Control Code Field) once (Count = 0x01) for ON 1 millisecond and OFF 0 milliseconds.

D.4.1.3: 32-Bit Binary Counter Without Flag (Obj. 20, Var. 5)

Counters support the following functions:

Read (Function 1)

A READ request for Variation 0 will be responded to with Variation 5.

Counters are used to communicate the following data measured by Shark meters:

Hour Readings

■ Hour Readings (Points 0 - 4)

Point	Readings	Unit
0	+W Hour	Wh
1	-W Hour	Wh
2	+VAR Hour	VARh
3	-VAR Hour	VARh
4	+VA Hour	VAh

* These readings may be cleared by using the Contol Relay Output Block.

D.4.1.4: 16-Bit Analog Input Without Flag (Obj. 30, Var. 4)

Analog Inputs support the following functions:

Read (Function 1)

A READ request for Variation 0 will be responded to with Variation 4.

Analog Inputs are used to communicate the following data measured by Shark meters:

- Health Check
- Phase-to-Neutral Voltage
- Phase-to-Phase Voltage
- Phase Current
- Total Power
- Three Phase Total VAs
- Three Phase Power Factor Total
- Frequency
- Three Phase +Watts Max Avg Demand
- Three Phase + VARs Max Avg Demand
- Three Phase -Watts Max Avg Demand
- Three Phase -VARs Max Avg Demand
- Three Phase VAs Max Avg Demand
- Angle, Phase Power
- Angle, Phase-to-Phase Voltage
- CT Numerator, Multiplier, Denominator
- PT Numerator, Multiplier, Denominator

■ Health Check (Point 0)

The Health Check point is used to indicate problems detected by the Shark meter. A value of zero (0x0000) indicates the meter does not detect a problem. Non-zero values indicate a detected anomaly.

■ Phase-to-Neutral Voltage (Points 1 - 3)

Point	Reading
1	Phase AN Voltage
2	Phase BN Voltage
3	Phase CN Voltage

These points are formatted as 2's complement fractions. They represent a fraction of a 150 V Secondary input. Inputs of above 150 V Secondary will be pinned at 150 V Secondary.

■ **Phase-to-Phase Voltage (Points 4 - 6)**

Point	Reading
4	Phase AB Voltage
5	Phase BC Voltage
6	Phase CA Voltage

These points are formatted as 2's complement fractions. They represent a fraction of a 300 V Secondary input. Inputs of above 300 V Secondary will be pinned at 300 V Secondary.

■ **Phase Current (Points 7 - 9)**

Point	Reading
7	Phase A Current
8	Phase B Current
9	Phase C Current

These points are formatted as 2's complement fractions. They represent a fraction of a 10 A Secondary input. Inputs of above 10A Secondary will be pinned at 10 A Secondary.

■ **Total Power (Points 10 - 11)**

Point	Reading
10	Total Watt
11	Total VAR

These points are formatted as 2's complement fractions. They represent a fraction of 4500 W Secondary in normal operation, or 3000 W Secondary in Open Delta operation. Inputs above/below +/-4500 or +/-3000 W Secondary will be pinned at +/-4500 or +/-3000 W Secondary, respectively.

■ **Total VA (Point 12)**

Point	Reading
12	Total VA

This point is formatted as a 2's complement fraction. It represents a fraction of 4500 W Secondary in normal operation, or 3000 W Secondary in Open Delta operation. Inputs above/below +/-4500 or +/-3000 W Secondary will be pinned at +/-4500 or +/-3000 W Secondary, respectively.

■ **Power Factor (Point 13)**

Point	Reading
13	Power Factor Total

This point is formatted as a 2's complement integer. It represents Power Factors from -1.000 (0x0FC18) to +1.000 (0x003E8). When in Open Delta operation, Total Power Factor (Point 13) is always zero.

■ **Frequency (Point 14)**

Point	Reading
14	Frequency

This point is formatted as a 2's complement fraction. It represents the Frequency as measured on Phase A Voltage in units of cHz (centiHertz, 1/100 Hz). Inputs below 45.00 Hz are pinned at 0 (0x0000), while inputs above 75.00 Hz are pinned at 9999 (0x270F).

■ **Maximum Demands of Total Power (Points 15 - 19)**

Point	Reading
15	Maximum Positive Demand Total Watts
16	Maximum Positive Demand Total VARs
17	Maximum Negative Demand Total Watts
18	Maximum Negative Demand Total VARs
19	Maximum Average Demand VA

These points are formatted as 2's complement fractions. They represent a fraction of 4500 W Secondary in normal operation, or 3000 W Secondary in Open Delta operation. Inputs above/below +/-4500 or +/-3000 W Secondary will be pinned at +/-4500 or +/-3000 W Secondary, respectively.

■ **Phase Angle (Points 20 - 25)**

Point	Reading
20	Phase A Current Angle
21	Phase B Current Angle
22	Phase C Current Angle
23	Volts A-B Angle
24	Volts B-C Angle
25	Volts C-A Angle

These points are formatted as 2's complement integers. They represent angles from -180.0° (0x0F8F8) to $+180.0^{\circ}$ (0x00708).

■ **CT & PT Ratios (Points 26 - 31)**

Point	Value
26	CT Ratio Numerator
27	CT Ratio Multiplier
28	CT Ratio Denominator
29	PT Ratio Numerator
30	PT Ratio Multiplier
31	PT Ratio Denominator

These points are formatted as 2's complement integers. They can be used to convert from units in terms of the Secondary of a CT or PT into units in terms of the Primary of a CT or PT. The ratio of Numerator divided by Denominator is the ratio of Primary to Secondary.

Shark meters typically use Full Scales relating Primary Current to 5 Amps and Primary Voltage to 120 V. However, these Full scales can range from mAs to thousands of kAs, or mVs, to thousands of kVs. Following are example settings:

CT Example Settings:

- 200 Amps: Set the Ct-n value for 200 and the Ct-S value for 1.
- 800 Amps: Set the Ct-n value for 800 and the Ct-S value for 1.
- 2,000 Amps: Set the Ct-n value for 2000 and the Ct-S value for 1.
- 10,000 Amps: Set the Ct-n value for 1000 and the Ct-S value for 10.

NOTE: CT Denominator is fixed at 5 for 5 ampere unit.

CT Denominator is fixed at 1 for 1 ampere unit.

PT Example Settings:

- 277 Volts (Reads 277 Volts): Pt-n value is 277, Pt-d value is 277, Pt-S value is 1.
- 120 Volts (Reads 14,400 Volts): Pt-n value is 1440, Pt-d value is 120, Pt-S value is 10.
- 69 Volts (Reads 138,000 Volts): Pt-n value is 1380, Pt-d value is 69, Pt-S value is 100.
- 115 Volts (Reads 347,000 Volts): Pt-n value is 3470, Pt-d value is 115, Pt-S value is 100.
- 69 Volts (Reads 347,000 Volts): Pt-n value is 347, Pt-d value is 69, Pt-S value is 1000.

D.4.1.5: Class 0 Data (Obj. 60, Var. 1)

Class 0 Data supports the following functions:

Read (Function 1)

A request for Class 0 Data from a Shark meter will return three Object Headers. Specifically, it will return 16-Bit Analog Input Without Flags (Object 30, Variation 4), Points 0 - 31, followed by 32-Bit Counters Without Flags (Object 20, Variation 5), Points 0 - 4, followed by Binary Output Status (Object 10, Variation 2), Points 0 - 1. (There is NO Object 1.)

A request for Object 60, Variation 0 will be treated as a request for Class 0 Data.

D.4.1.6: Internal Indications (Obj. 80, Var. 1)

Internal Indications support the following functions:

Write (Function 2)

Internal Indications may be indexed by Qualifier Code 0.

■ Device Restart (Point 0)

This bit is set whenever the meter has reset. The polling device may clear this bit by Writing (Function 2) to Object 80, Point 0.

Appendix E

Using the USB to IrDA Adapter (CAB6490)

E.1: Introduction

Com 1 of the Shark[®] 100 meter is the IrDA port, located on the face of the meter. One way to communicate with the IrDA port is with EIG's USB to IrDA Adapter (CAB6490), which allows you to access the Shark[®] meter's data from a PC. This Appendix contains instructions for installing the USB to IrDA Adapter.

E.2: Installation Procedures

The **USB to IrDA Adapter** comes packaged with a **USB cable** and an **Installation CD**. Follow this procedure to install the Adapter on your PC.

1. **Connect** the **USB cable** to the **USB to IrDA Adapter**, and **plug** the USB into your PC's **USB port**.
2. Insert the **Installation CD** into your PC's CD ROM drive.
3. You will see the screen shown below. The **Found New Hardware Wizard** allows you to install the software for the Adapter. Click the Radio Button next to **Install from a list or specific location**.



4. Click **Next**. You will see the screen shown on the next page.

Select these options

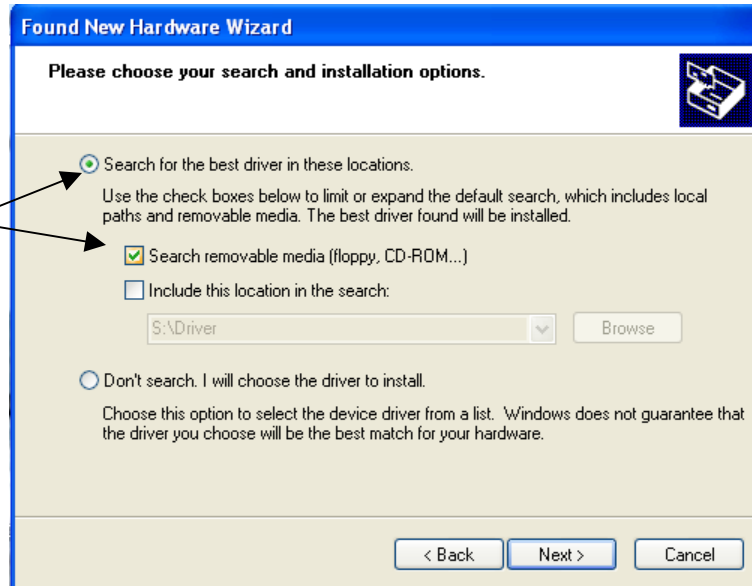

5. Make sure the **first Radio Button** and the **first Checkbox** are selected, as shown in the above screen. These selections allow the Adapter's driver to be copied from the Installation disk to your PC.

6. Click **Next**. You will see the screen shown below.

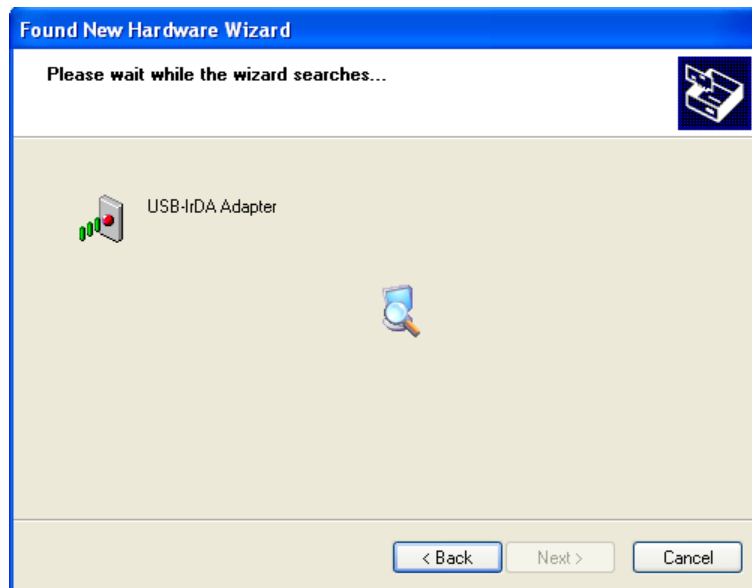

7. When the **driver** for the **Adapter** is found, you will see the screen shown on the next page.

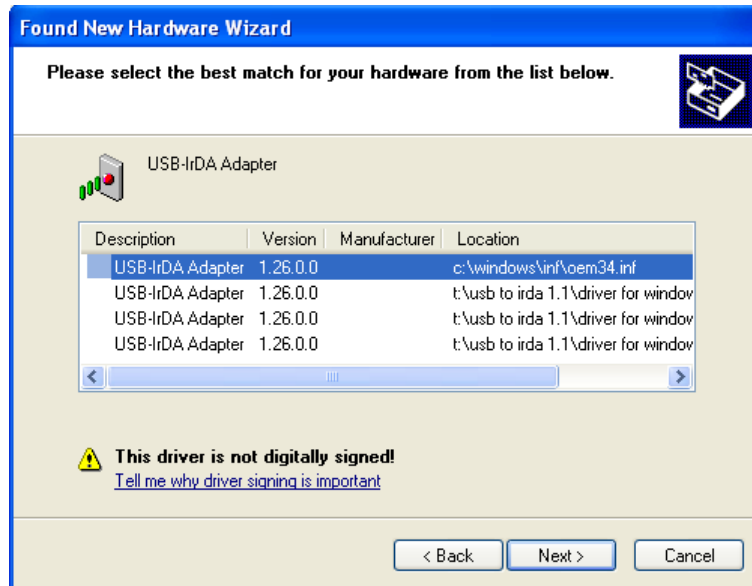

8. You do not need to be concerned about the message on the bottom of the screen. Click **Next** to **continue** with the installation.
9. You will see the two windows shown below. Click **Continue Anyway**.



10. You will see the screen shown on the next page while the Adapter's **driver** is being **installed** on your PC.

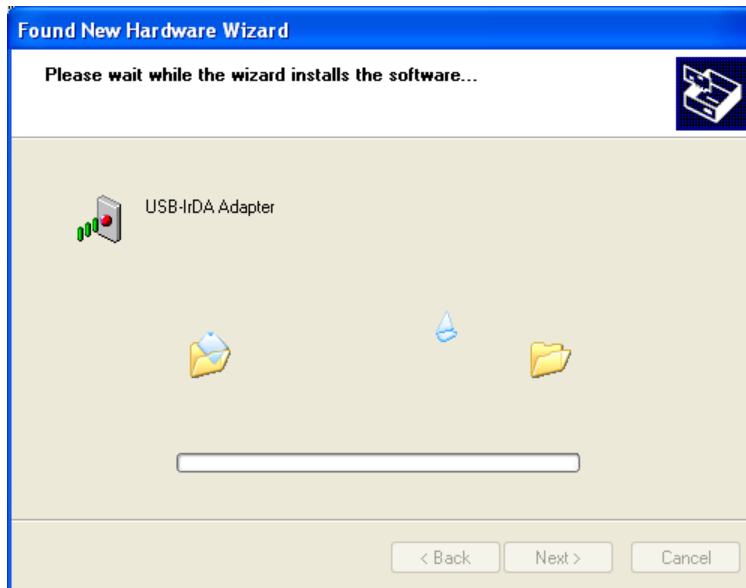

11. When the **driver installation is complete**, you will see the screen shown below.



12. Click **Finish** to close the **Found New Hardware Wizard**.

IMPORTANT! Do NOT remove the Installation CD until the entire procedure has been completed.

13. Position the **USB to IrDA Adapter** so that it points directly at the **IrDA** on the front of the Shark[®] 100 meter. It should be as close as possible to the meter, and not more than 15 inches/38 cm away from it.

14. The **Found New Hardware Wizard** screen opens again.



This time, click the Radio Button next to **Install the software automatically**.

15. Click **Next**. You will see the screen shown below.

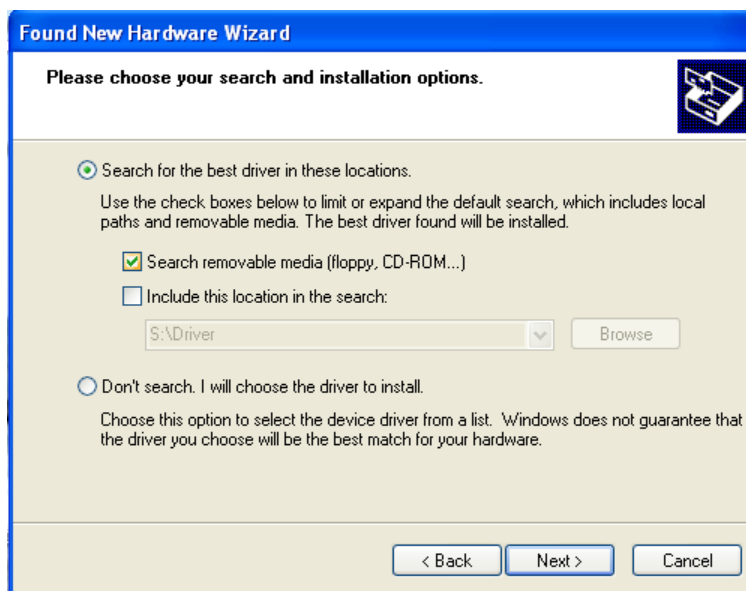

16. Make sure the **first Radio Button** and the **first Checkbox** are selected, as shown in the above screen. Click **Next**. You will see the two screens shown on the next page.

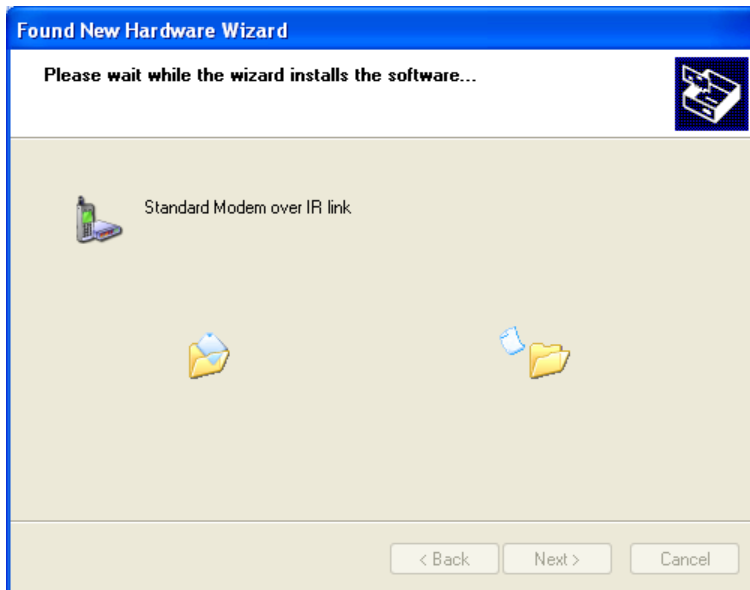
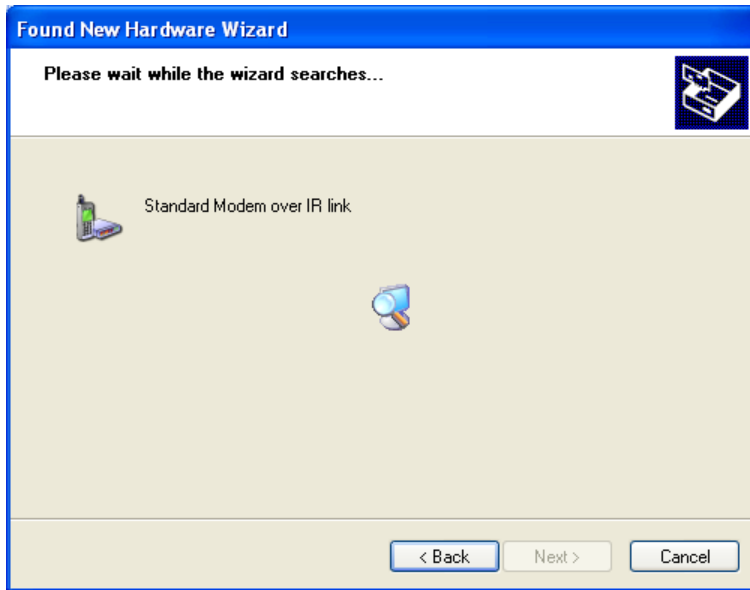

17. When the **installation is complete**, you will see the screen shown on the next page.

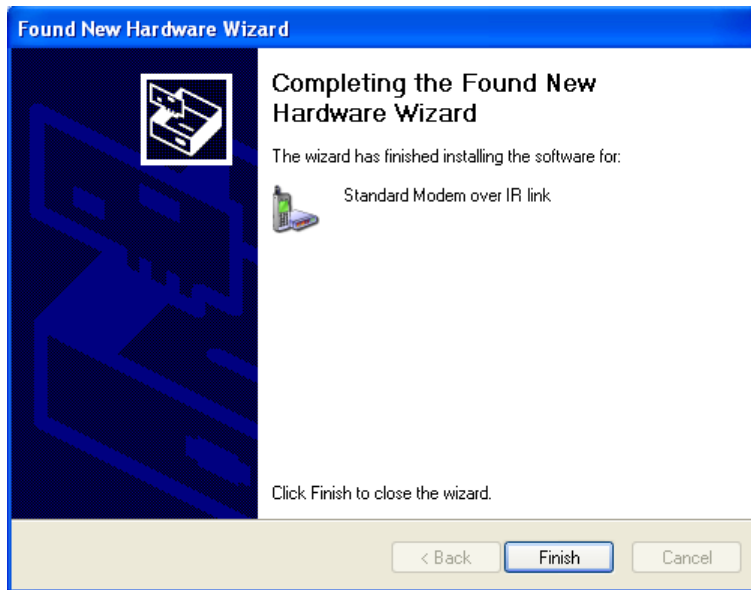

Click **Finish** to close the **Found New Hardware Wizard**.

18. To **verify** that your Adapter has been installed properly, click **Start>Settings>Control Panel>System>Hardware>Device Manager**. The USB to IrDA Adapter should appear under both Infrared Devices and Modems (click on the + sign to display all configured modems). See the example screen below.

NOTE: If the Adapter doesn't show up under Modems, move it away from the meter for a minute and then position it pointing at the IrDA, again.

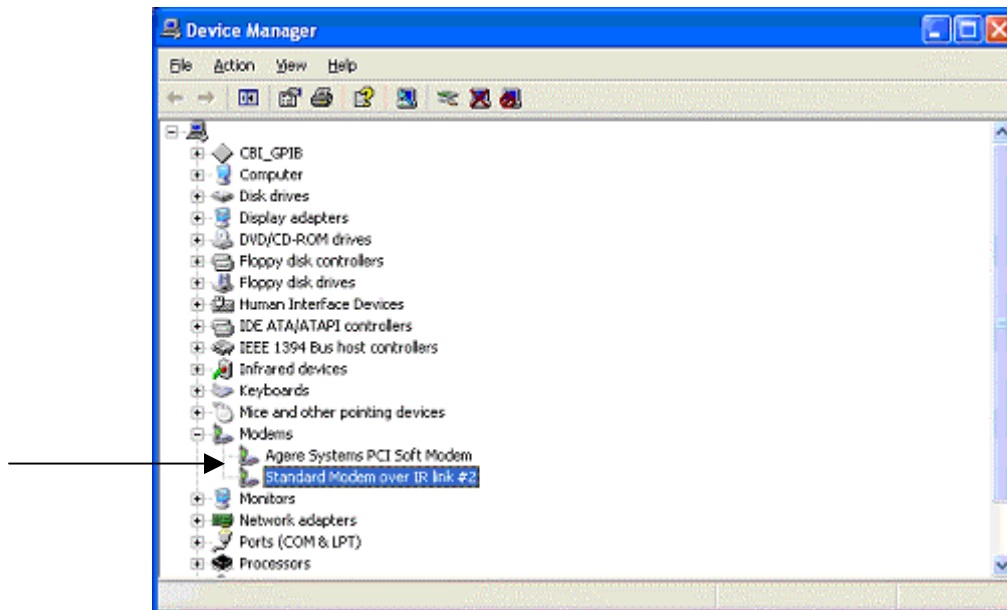

19. Double-click on the **Standard Modem over IR link** (this is the USB to IrDA Adapter). You will see the **Properties** screen for the Adapter.

20. Click the **Modem** tab. The **Com Port** that the Adapter is using is displayed in the screen.

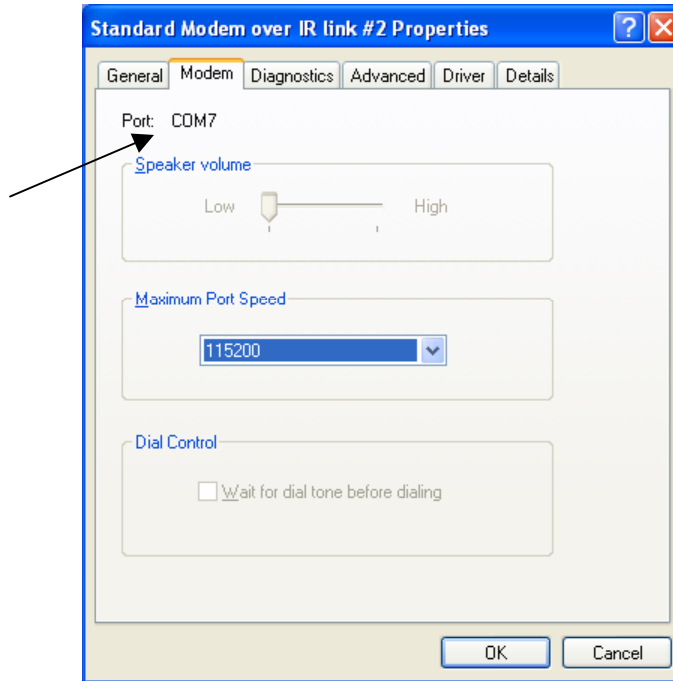

21. Use this **Com Port** to connect to the meter from your PC, using the **Communicator EXT** software. Refer to Chapter 5 of the *Communicator EXT 3.0 User's Manual* for detailed connection instructions.