

Instruction Manual

Installation • Operation • Maintenance

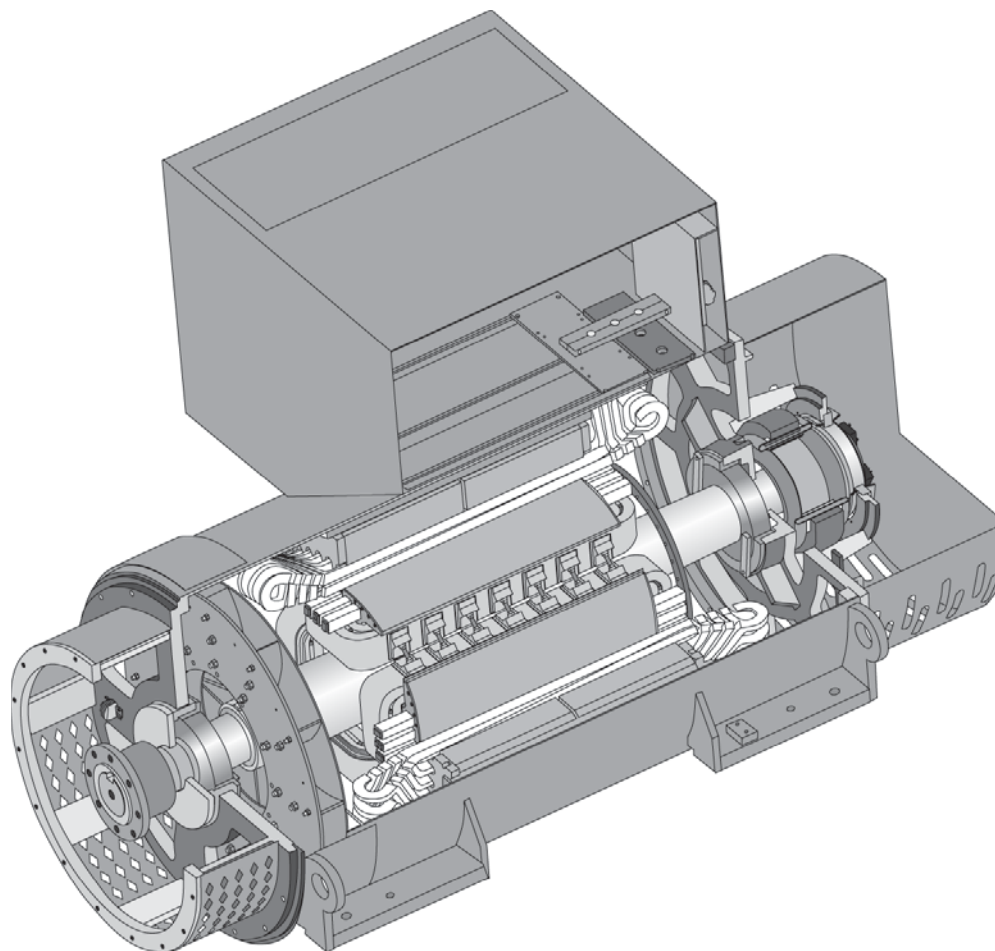

Standard AC generator

Single or two-bearing
Drive-end air discharge



Lerov Somer North America

Kato Engineering Inc.
P.O. Box 8447
Mankato, MN USA
56002-8447
Tel: 507-625-4011
Fax: 507-345-2798
Email: katoengineering@emerson.com
www.kato-eng.com

Table of Contents

Introduction.....	4
Foreword.....	4
Safety instructions.....	4
Ratings/description.....	4
Construction and Operating Principles.....	5
Stator.....	5
Rotor.....	5
Bearings.....	5
Connection boxes.....	6
Excitation system.....	6
Optional PMG system.....	7
Other options.....	7
Installation.....	8
Receiving inspection.....	8
Unpacking and moving.....	8
Location.....	8
Base design.....	8
Assemble to prime mover, alignment.....	8
Two-bearing alignment.....	9
Two-bearing close-coupled alignment.....	11
Single-bearing alignment.....	17
Foot deflection.....	22
Doweling.....	22
Electrical connections.....	22
Space heaters.....	22
Inspection before startup.....	23
Operation.....	24
Initial startup: generators w/auto & manual control.....	24
Initial startup: generators w/auto control only.....	24
Restoring residual magnetism/field flashing.....	25
Continuous operation.....	26
Idling.....	27
Parallel operation.....	27

Note: Because of rapid changes in designs and processes and the variability of Kato Engineering's products, information in this manual must not be regarded as binding and is subject to change without notice.

The image on the front cover is representative only. Several variations are available within the range of generators covered within this manual.

Maintenance.....	29
Schedules.....	29
Maintenance procedures.....	31
Visual inspection methods of windings.....	31
Cleaning.....	32
Insulation resistance tests at low voltage.....	33
Dry out procedures.....	35
Bearing lubrication.....	35
Rectifier tests.....	36
Disassembly.....	38
Overall disassembly.....	38
Exciter armature and PMG removal.....	39
Bearing removal.....	41
Assembly.....	41
Bearing installation.....	41
Overall assembly.....	42
Exciter armature and PMG installation.....	42
Storage.....	43
Troubleshooting Guide.....	44
Appendices.....	47
List of equipment required for installation and maintenance.....	47
Main part location.....	48

Introduction

Foreword

This manual contains instructions for installing, operating and maintaining Kato Engineering AC brushless revolving field generators. These generators are manufactured in many sizes and ratings and with various options.

Note: For specific lubrication instructions, always refer to the bearing lubrication sheet that came with your manual or the lube plate on the generator.

Lubrication information, electrical connection drawings, dimensional drawings and parts listings for your model are contained in the manual package as supplementary information and are the specific source of information for making connections and ordering replacement parts. Information about optional components of your generator may also be contained as a supplement.

Please read this manual and all included manuals in its entirety before unpacking, installing, and operating your generator. If your manual came on a CD, read all the files included on the CD.

Safety instructions

In order to prevent injury or equipment damage, everyone involved in installation, operating and maintenance of the generator described in this manual must be qualified and trained in the current safety standards that govern his or her work.

While “common-sense” prevention of injury or equipment damage cannot be completely defined by any manual (nor built into any piece of equipment), the following paragraphs define warnings, cautions, and notes as they are used in this manual:

Warning: Warnings identify an installation, operating or maintenance procedure, practice, condition, or statement that, if not strictly followed, could result in death or serious injury to personnel.

Caution: Cautions identify an installation, operating or maintenance procedure, practice, condition, or statement that, if not strictly followed, could result in destruction of or damage to equipment or serious impairment of system operation.

Note: Notes highlight an installation, operating or maintenance procedure, condition, or statement and are essential or helpful but are not of known hazardous nature as indicated by warnings and cautions.

Ratings/description

Nameplates, which are located on the side of the generator, include serial and model number as well as rating information and bearing and lubrication information.

Construction and Operating Principles

Stator

The stator consists of the supporting frame, core, and armature windings.

The stator core is made from laminations, thin sheets of electrical steel, which are stacked and held in place by steel endrings and support bars. The rings and bars are welded to or are part of the steel frame. Base mounting plates are welded to the bottom of the frame. The base mounting plates allow the assembly to be mounted on the genset base.

The windings (coils) are constructed of layered and insulated copper wire. The coils are inserted in the core slots, connected together, and the entire assembly is vacuum-pressure impregnated with resin. Stator leads terminate in standard connection lug or strap terminals for ease of connection to the load.

Rotor

The main rotor assembly is the revolving field. It consists of windings in a core, which is in turn mounted on a steel shaft. The exciter armature assembly and optional permanent magnet generator (PMG) rotor are also mounted on the shaft as are the fan(s) and other optional accessories. The core consists of laminations, thin sheets of electrical steel, which are stacked together. The core makes the salient poles (four, six, eight or 10). With six or more poles, the poles are typically attached to a center hub.

The rotor windings consists of insulated magnet wire wound around each pole. V-blocks between each pole keep the rotor windings in place. Damper windings consist of copper or aluminum rods that are inserted through each pole surface and are brazed to copper or aluminum damper end plates at each end of the lamination stack. The end plates are brazed to adjacent poles to form a continuous damper winding. The ends of the windings are supported with bars or aluminum pole shoes. The rotor either has resin applied during the winding process or is vacuum-pressure impregnated with resin.

The shaft is made from high-strength rolled or forged steel and machined to accommodate all the rotating generator components. Keyways in the shaft ensure precise positioning of the rotor, exciter armature, and optional PMG rotor as well as drive couplings. On the exciter side, the shaft has a slot or hole in its centerline for running the revolving field leads to the rectifier.

Bearings

The generator may contain either one or two bearings. Bearings are typically ball or roller type and are regreaseable bearings, which contain fill and drain ports for easy lubrication. Sleeve bearings are optional on some designs. A supplementary instruction will be included in

Note: For specific lubrication instructions, always refer to the bearing lubrication sheet that came with your manual or the lube plate on the generator.

the manual package for sleeve bearings if they are applicable to this generator. Some smaller generators may use heavy duty double shielded bearings, which are typically used on smaller generators and are greased for life.

Connection boxes

The main lead connection box houses the load lead terminals. In addition, the generator may have auxiliary connection boxes for connecting temperature detector outputs, space heater connectors, and sensing outputs.

Excitation system

The excitation system consists of the exciter stator assembly and the exciter armature assembly:

The exciter stator assembly consists of windings in a core. The core is made from steel laminations that are stacked and welded together. The main exciter stator coils are placed in slots in the core and form alternate north and south poles. The entire assembly is either mounted to the end bracket or mounted in a frame, which is mounted to the end bracket. The stator is a stationary field, which is powered by the voltage regulator.

The assembly consists of two subassemblies: the exciter armature and the rotating rectifier. The exciter armature assembly contains steel laminations that are stacked and keyed on the shaft or on to a sleeve, which is keyed to the generator shaft. A three-phase winding is inserted into slots in the laminations. The coils are held in place by insulating wedges. The coil extensions are braced with tape. Output leads from the winding are connected to the rotating rectifier assembly.

The rotating rectifier is a three-phase full wave bridge rectifier, converting the AC from the exciter armature to DC, which is transferred to the revolving field windings. Two aluminum steel plates, each containing three rotating rectifier diodes, are mounted on each side of an insulating hub to form the negative and positive terminals. The plates also act as heat sinks for the diodes.

Excitation system functional overview: Exciter field control is established by the strength of the exciter field current developed by the voltage regulator system. The DC voltage and current levels of the exciter field signal from the voltage regulator varies depending upon the generator output voltage and the loading of the output lines (see Figure 1).

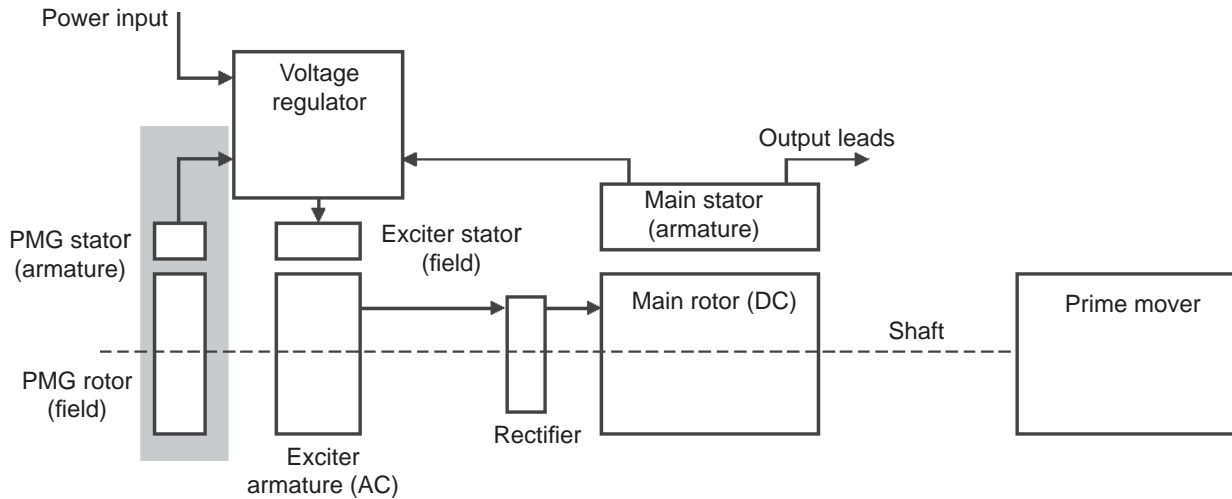

Figure 1: Overview of excitation system
(with an optional PMG)

Optional PMG system

The permanent magnet generator (PMG) system consists of the PMG stator and PMG rotor:

The PMG stator is a stationary armature and is located within the stator assembly that also contains the exciter stator or is a separate stator mounted next to the exciter stator. The PMG stator consists of steel laminations. The laminations are held in place by steel compression rings and are welded to the frame bars of the exciter-PMG frame. The PMG windings are placed in slots in the laminations. Insulating wedges are inserted at the top of each slot to hold the coils in position.

The PMG rotor consists of rectangular permanent magnets and cast pole tips secured to a steel hub with nonmagnetic stainless steel bolts. The PMG rotor is keyed to the shaft and secured with a nut and lock washer.

PMG system overview: The PMG system functions as a pilot exciter, providing power to the automatic voltage regulator power supply. The PMG is an AC generator that uses permanent magnets in the rotor instead of electromagnets to provide the magnetic field (see Figure 1).

Other options

Other options include, but are not limited to, space heaters, filters, and temperature sensing devices.

Installation

Warning: *Be alert at all times when installing, operating and maintaining the generator. Avoid contact with the uninsulated metal parts of the generator. Most injuries occur from faulty ground connections on portable electrical equipment and failure to ground stationary equipment.*

Test all portable devices frequently to prove that a solid electrical circuit exists from the metal frame through the grounding conductor, in the electrical cord, to the grounding contact in the attachment plug. Do not use electrical equipment with frayed, burned or damaged cords. Always take extreme care when moving the generator. Be careful to not strike objects or personnel.

Apply lifting force to structural points specifically provided for lifting. Do not use the enclosure lifting holes to lift the whole unit. Use lifting means adequate for the weight. Observe lifting notices attached to the generator. Failure to observe these instructions can result in injury and damage to the generator.

Caution: *Do not attempt to transport a single-bearing generator without maintaining proper rotor support and with the exciter rotor assembly removed. Failure to observe this warning can result in equipment damage.*

Caution: *Blocking or restriction of normal air flow into or out of the generator may cause damage to the electrical windings.*

Receiving inspection

Before accepting a shipment, examine the packaging for any sign of damage that might have occurred during transit. Report any damage to the transportation company and Kato Engineering.

Unpacking and moving

If the generator is received during cold weather, reduce condensation on cold surfaces and failure due to wet windings by allowing the generator to reach room temperature before removing the protective packing.

Unpack the generator carefully to avoid scratching painted surfaces. Do not remove the protecting lubricant from the shaft end or drive plates. Inspect for loosely mounted components and the presence of moisture. Inspect to make certain foreign material, such as crating nails, loose bolts or packing material, which may have fallen into the machine during unpacking, is removed. If damage is noted, determine the extent of damage and immediately notify the transportation company claims office and Kato Engineering. Be sure to give complete and accurate details when reporting damage.

Move the generator by attaching an overhead hoist to the eyebolts installed on the generator frame or by lifting the generator from underneath the skid with a forklift.

Single-bearing generators are shipped with the exciter rotor assembly removed from the shaft and a support mounted across the drive discs to support the rotor.

Location

Install the generator in an area so it complies with all local and industrial regulations. Locate it in a clean, dry, well-vented area or area that is suitable for the generator enclosure. Make sure it is easily accessible for inspection and maintenance.

Check winding insulation resistance before placing the generator in operation (see the maintenance section).

Protect generators operating intermittently in very damp locations with space heaters. Slowly warm generators placed in operation after being subjected to very low temperatures to prevent excessive condensation.

Base design

The type of base to be used will depend upon the nature of the installation site. However, the generator base must be rigid, level, and free from vibration. Mounting holes must be larger than the fasteners to allow for alignment.

Assemble to prime mover, alignment

Follow either the two-bearing alignment (if your generator model has two bearings but no adapter to bolt to an engine flywheel housing), two-bearing close-coupled alignment (if your generator model has two bearings and an adapter for bolting to a flywheel housing), or single-bearing alignment (if your generator has one bearing and drive plates). Consult the factory for belt or gear drive alignment).

Two-bearing alignment

Follow the tolerances specified by the coupling manufacturer when they are less than described in this manual.

Use shims, if necessary, between the mounting pad and the base to properly level and align the generator to the prime mover.

Install the coupling(s) on the generator and engine drive shafts in accordance with coupling manufacturer installation procedures. Use a straight edge and a thickness gauge for rough alignment as shown in Figure 2. Check for angular and parallel alignment as follows:

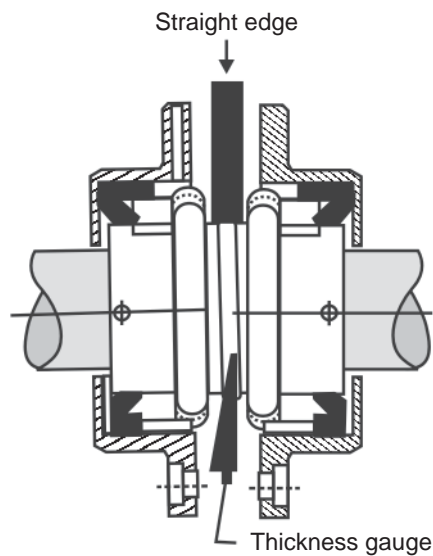

Figure 2: Rough alignment

Angular alignment: Fasten a dial indicator to one of the coupling halves, and scribe the position of the dial button on the face of the opposite coupling half as shown in Figure 3. Rotate both shafts simultaneously, keeping the finger or button on the indicator at the reference mark on the coupling hub. Note the reading on the indicator dial at each one quarter revolution.

A variation of readings at different positions will indicate how the machine needs to be adjusted to obtain a maximum misalignment of 0.001 inch for each inch of the coupling hub's radius, total indicator runout. Place or remove slotted shims from under the front or rear engine or generator mounting pads and/or shift the front or back half of one component from side to side until the components are properly aligned. Tighten the mounting bolts, and recheck alignment.

Notes: *Mounting of the indicators must allow complete rotation of the prime mover.*

Use dial indicators that are rigid so indicator sag won't be a factor. Using the shortest offset distance of the indicator bracket will reduce the effects of indicator droop or sag.

During alignment, you may also need to compensate for engine expansion due to heating. Generator expansion is generally not considered a factor.

If the genset is moved to a different location, check alignment before startup.

Caution: *Do not pry on the generator fan.*

Caution: *Generators equipped with sleeve oil bearings must have oil added to the bearing prior to rotation. See the bearing manual.*

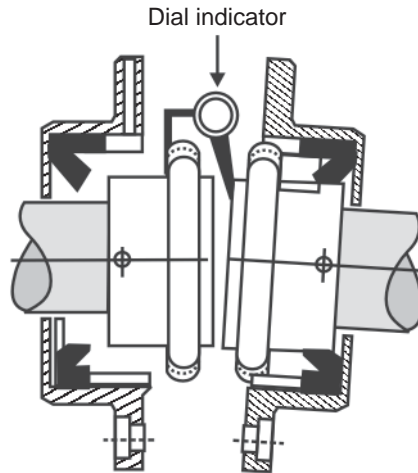

Figure 3: Angular alignment

Parallel alignment: Fasten a dial indicator to one of the coupling halves, and scribe the position of the dial button on the top of the opposite coupling half as shown in Figure 4. Rotate both shafts simultaneously, keeping the finger or button on the indicator at the reference mark on the coupling hub. Note the reading on the indicator dial at each one quarter revolution. A variation of readings at different positions will indicate how the machine needs to be adjusted to obtain a maximum misalignment of 0.002 inch. Place or remove slotted shims from under all of the engine or generator mounting pads and/or shift one component from side to side until the components are properly aligned. Tighten the mounting bolts, and recheck alignment.

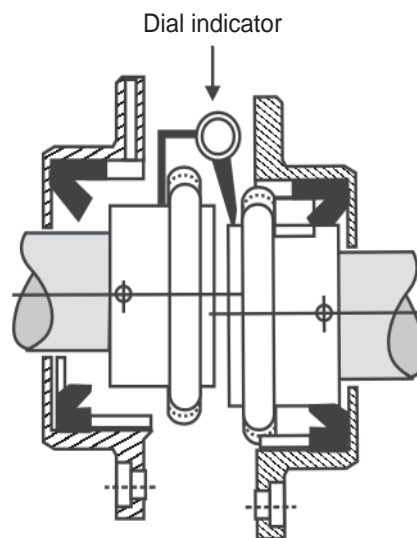

Figure 4: Parallel alignment

Two-bearing close-coupled alignment

Check the engine flywheel housing pilot's radial and face runout by mounting a dial indicator and measuring the flywheel to the flywheel housing as shown in Figure 5. See Table 1 for maximum allowable runout.

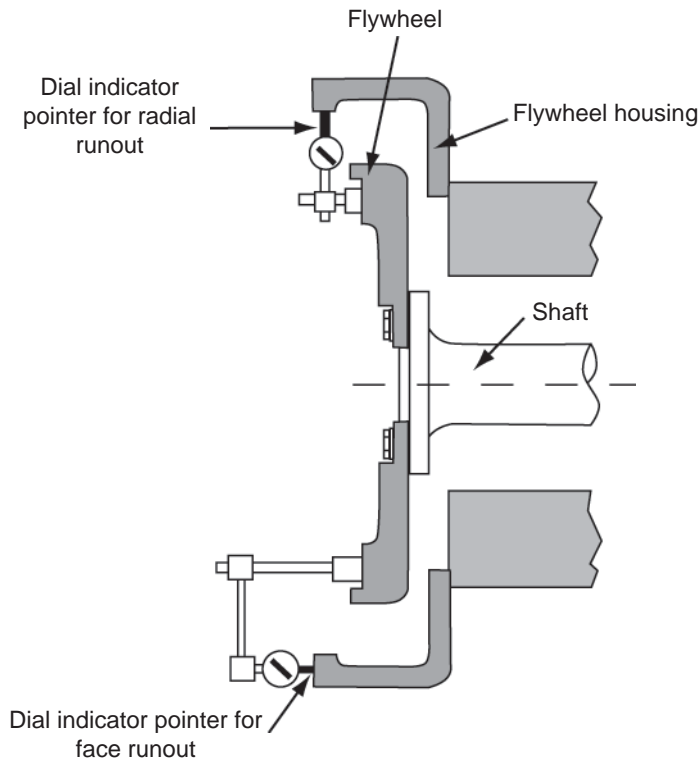

Figure 5: Flywheel housing check

SAE housing number	Housing inside dia.	Allowable runout (TIR)
6	10.500	0.002
5	12.375	0.003
4	14.250	0.003
3	16.125	0.004
2	17.625	0.004
1	20.125	0.005
0.5	23.000	0.005
0	25.500	0.006
00	31.000	0.007

Table 1: Maximum allowable flywheel housing runout (inches)

Notes: Mounting of the indicators must allow complete rotation of the prime mover.

Use dial indicators that are rigid so indicator sag won't be a factor. Using the shortest offset distance of the indicator bracket will reduce the effects of indicator droop or sag.

During alignment, you may also need to compensate for engine expansion due to heating. Generator expansion is generally not considered a factor.

If the genset is moved to a different location, check alignment before startup.

Caution: Do not pry on the fan.

Caution: Generators equipped with sleeve oil bearings must have oil added to the bearing prior to rotation. See the bearing manual.

Check the engine flywheel's radial and face runout by mounting a dial indicator and measuring the flywheel housing to the flywheel as shown in Figure 6. See Table 2 for maximum allowable runout.

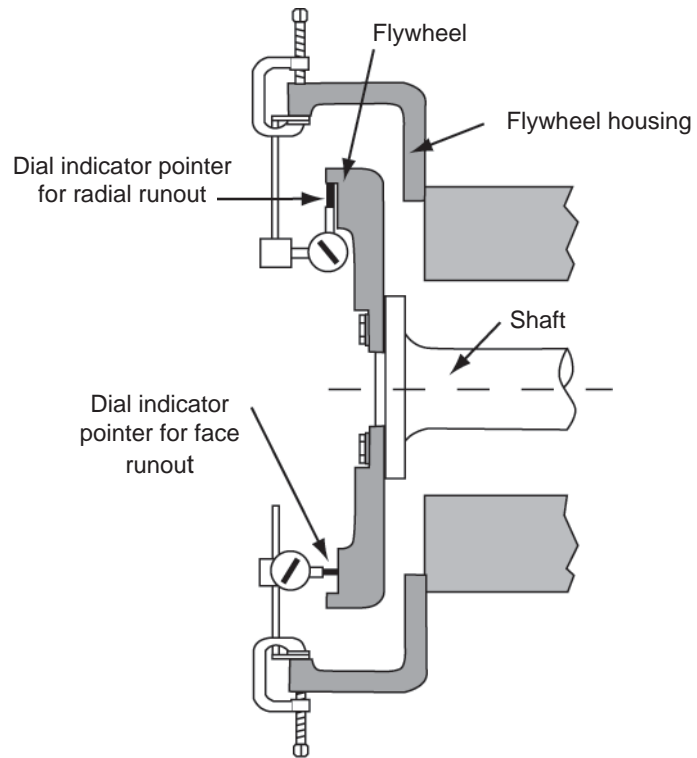

Figure 6: Flywheel check

Pilot diameter	Allowable runout (TIR)
6.5	0.002
7.5	0.002
8	0.002
10	0.003
11.5	0.003
14	0.004
16	0.005
18	0.005
21	0.006
24	0.007

Table 2: Maximum allowable fly-wheel runout (inches)

Check the generator adapter's radial and face runout by mounting a dial indicator on the generator shaft or coupling as shown in Figure 7. The maximum radial and face runout on the generator adaptor must not exceed 0.010 inch.

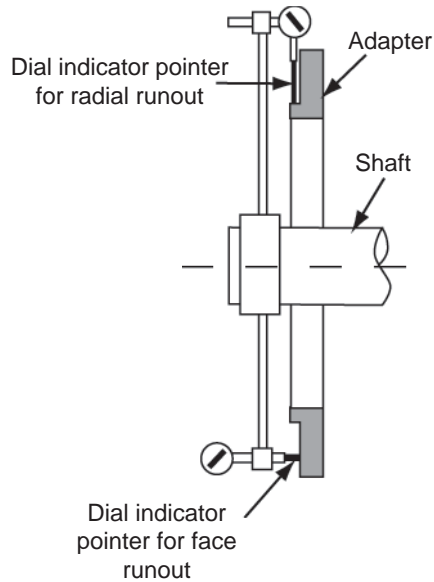

Figure 7: Generator adapter check

Check the generator coupling's radial and face runout by mounting a dial indicator to the generator adapter as shown in Figure 8. The maximum radial and face runout on the coupling must not exceed 0.003 inch.

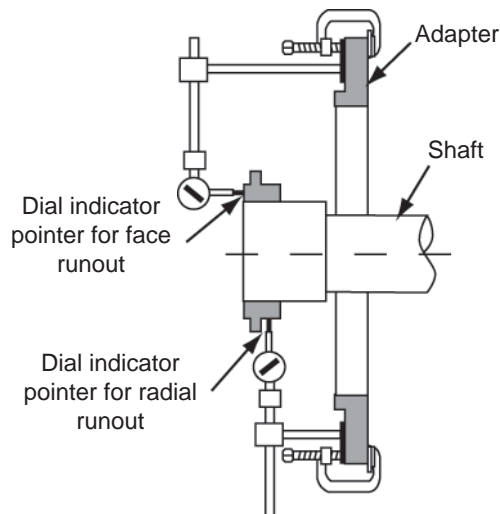

Figure 8: Generator coupling check

Install the portion of the coupling that fits into the engine flywheel following the manufacturer's recommended procedures and in accordance with engine manufacturer's specifications. Check the coupling's radial and face runout by mounting a dial indicator to the engine flywheel housing as shown in Figure 9. The maximum radial and face runout on the coupling must not exceed 0.004 inch.

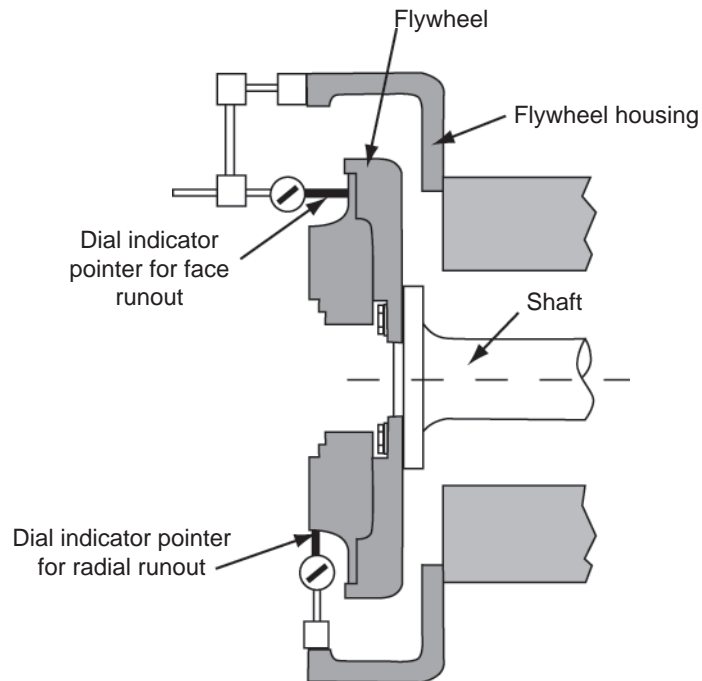

Figure 9: Engine coupling check

Measure and record the engine crank shaft endplay and generator endplay. Set the engine endplay to the manufacturer's recommended position for alignment. Verify the generator end-float is set at a position of one half of the measured distance or at a position that will allow full thermal growth of the generator shaft when operated at rated temperatures.

Mount the generator on the skid, and move the generator to within 0.010 inch of the engine. Place two 0.010-inch shims in the horizontal (9 o'clock and 3 o'clock) positions between the generator adapter and the engine flywheel housing. Raising the rear, exciter end of the generator as necessary, place two 0.010-inch shims in the vertical (6 o'clock and 12 o'clock) positions between the generator adapter and the engine flywheel housing. This will give a good starting point for alignment. Remove the vertical shims at this time. (If necessary, mark holes to be drilled on the base, and remove the generator at this time.)

Mount a dial indicator on the generator shaft or half coupling to the flywheel radial surface for parallel alignment as shown in Figure 10. Mount a dial indicator on the flywheel coupling to the face of the generator half coupling for angular alignment as shown in Figure 10. Align the engine by rotating the prime mover in 90-degree increments and measuring total indicator runout. Tighten the generator to the base before taking each set of readings. Raise or lower the generator by adding or removing shims under the machined feet.

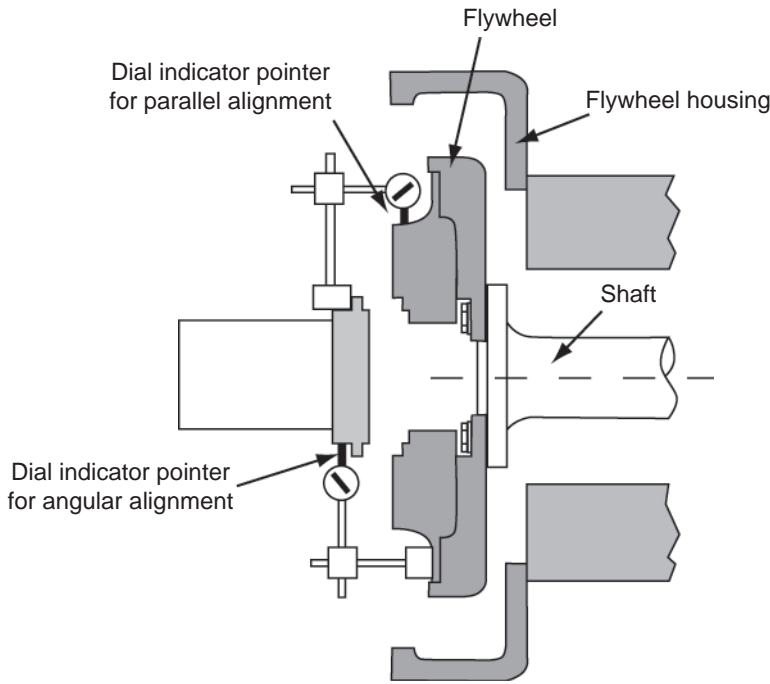
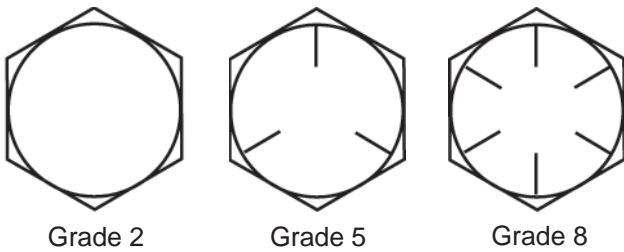

Figure 10: Alignment check

Following the final generator adjustment and runout check, remove the horizontal shims from the adaptor flywheel housing, and move the generator all the way to the adaptor. Then tighten the fasteners. Recheck alignment. Make sure angularity (face) total indicated runout does not exceed 0.001 inch per inch of generator shaft diameter and parallel (radial) total indicated runout does not exceed 0.003 inch.

Note: Clearances between the adaptor pilot and the flywheel housing recess are designed to meet the tolerance of 0.001 to 0.015 inches.

Torque the fasteners to the value shown in Table 3.



Grade 2

Grade 5

Grade 8

ASTM & SAE grade markings

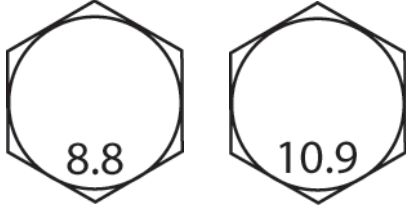

Class 8.8

Class 10.9

Metric grade markings

1-NM = 0.737 ft-lbs. = 8.85 in-lbs.

Grade 2						
Size	in-lbs.		ft-lbs		N-M	
	Min.	Max.	Min.	Max.	Min.	Max.
4-40	3.3	4.7			0.4	0.5
6-32	6.1	8.7			0.7	1.0
8-32	12.5	17.8	1.0	1.5	1.4	2.0
10-32	20.8	29.7	1.7	2.5	2.3	3.4
1/4-20	50.4	72.0	4.2	6.0	5.7	8.1
5/16-18	92.4	132.0	7.7	11.0	10.4	14.9
3/8-16	159.6	228.0	13.3	19.0	18.0	25.8
7/16-14	252.0	360.0	21.3	30.0	28.5	40.7
1/2-13	378.0	540.0	31.5	45.0	42.7	61.0
9/16-12			46.2	66.0	62.6	89.5
5/8-11			65.1	93.0	88.3	126.1
3/4-10			105.0	150.0	142.4	203.4
7/8-9			141.4	202.0	191.7	273.9

Grade 5						
Size	in-lbs.		ft-lbs		N-M	
	Min.	Max.	Min.	Max.	Min.	Max.
1/4-20	60	84	5	7	6.8	9.5
5/16-18	120	192	10	16	13.5	21.7
3/8-16	228	336	19	28	25.8	38
7/16-14	360	528	30	44	40.7	59.7
1/2-13	540	804	45	67	61	90.8
9/16-12	792	1152	66	96	89.5	130.2
5/8-11	1104	1608	92	134	124.7	181.7
3/4-10	2052	2724	171	227	231.8	307.8
7/8-9	3372	4368	281	364	381	493.5
1-8	5160	6432	430	536	583	726.7

Grade 8						
Size	in-lbs.		ft-lbs		N-M	
	Min.	Max.	Min.	Max.	Min.	Max.
10-32	36	49			4.1	5.5
1/4-20	72	144	6	12	8.1	16.3
5/16-18	156	276	13	23	17.6	31.2
3/8-16	324	444	27	37	36.6	50.2
7/16-14	480	720	40	60	54.2	81.3
1/2-13	780	1020	65	85	88.1	115.2
9/16-12	1140	1500	95	125	128.3	169.5
5/8-11	1560	2040	130	170	176.8	230.5
3/4-10	2760	3600	230	300	311.8	406.7
7/8-9	4320	5760	660	480	488.1	650.8
1-8	6720	8640	560	720	759.3	976.2

Class 8.8						
Size	in-lbs.		ft-lbs		N-M	
	Min.	Max.	Min.	Max.	Min.	Max.
M4	20	32	1.7	2.7	2.3	3.6
M5	40	64	3.3	5.4	4.5	7.3
M6	65	113	5.4	9.4	7.3	12.8
M8	168	264	14	22	20	30
M10	324	516	27	43	38	58
M12	612	900	51	75	69	101
M14	960	1428	80	119	109	161
M16			126	184	170	250
M18			183	243	248	330
M20			263	341	357	463
M22			367	457	497	619
M24			465	580	631	787

Class 10.9						
Size	in-lbs.		ft-lbs		N-M	
	Min.	Max.	Min.	Max.	Min.	Max.
M4	22	36	1.8	3	2.5	4.1
M5	46	74	3.8	6.2	5.2	8.4
M6	77	122	6.4	10.2	8.7	13.8
M8	192	288	16	24	22	32
M10	384	576	32	48	43	66
M12	672	996	56	83	77	112
M14	1080	1554	90	132	122	179
M16			140	206	190	279
M18			205	271	277	368
M20			294	381	398	517
M22			409	510	554	691

Table 5: Recommended lubricated torque values. (If no lubricant is used, increase values by 25%.)

Single-bearing alignment

Before assembling the generator to the prime mover, remove the exciter cover and adapter cover. Remove the blocking holding the drive discs to the adapter. Also make sure the generator bearing end clearance is not less than the total engine crankshaft axial movement plus 1/16 inch. The generator is shipped from the factory with 1/8-inch minimum bearing end clearance. (This dimension is recorded on the Factory Recorded Dimensions sheet, packaged with the generator.)

Measure the distance from the end of the exciter shaft extension to the bearing housing on the endbracket (dimension A in Figure 11). This dimension is recorded on the Factory Recorded Dimensions sheet, packaged with the generator. If the dimensions do not match, move the rotor axially relative to the stator until the dimensions are equal.

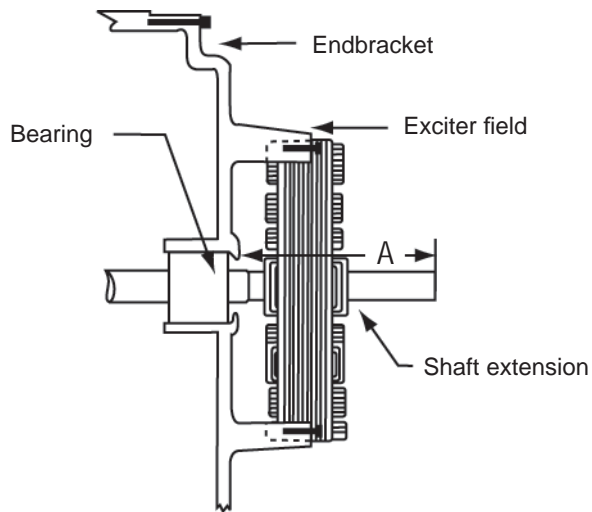

Figure 11: Generator coupling check

Notes: *Mounting of the indicators must allow complete rotation of the prime mover.*

Use dial indicators that are rigid so indicator sag won't be a factor. Using the shortest offset distance of the indicator bracket will reduce the effects of indicator droop or sag.

During alignment, you may also need to compensate for engine expansion due to heating. Generator expansion is generally not considered a factor.

If the genset is moved to a different location, check alignment before startup.

Caution: *Do not pry on the generator fan.*

Caution: *Generators equipped with sleeve oil bearings must have oil added to the bearing prior to rotation. See the bearing manual.*

Check the engine flywheel housing pilots's radial and face runout by mounting a dial indicator and measuring the flywheel to the flywheel housing as shown in Figure 5. See Table 1 for maximum allowable runout.

Check the engine flywheel's radial and face runout by mounting a dial indicator and measuring the flywheel housing to the flywheel as shown in Figure 6. See Table 2 for maximum allowable runout.

Caution: *Never grind the OD of drive discs or attempt to drill out the holes. If the drive discs do not fit properly, use different discs or a different flywheel.*

Measure the generator drive plate diameter (dimension S of Figure 12) and flywheel bore diameter (dimension B of Figure 13). Drive plate diameter must not be greater than the flywheel bore diameter. Also check to make sure the hole centers match (dimension W of Figure 12 and dimension C of Figure 13).

Measure the axial distance from the surface on the generator adaptor to the outside surface on the drive disc coupling plates (dimension Y in Figure 12). This dimension is recorded on the Factory Recorded Dimensions sheet, which was packaged with the generator. If the dimensions do not match, move the rotor axially relative to the stator until the dimensions are equal.

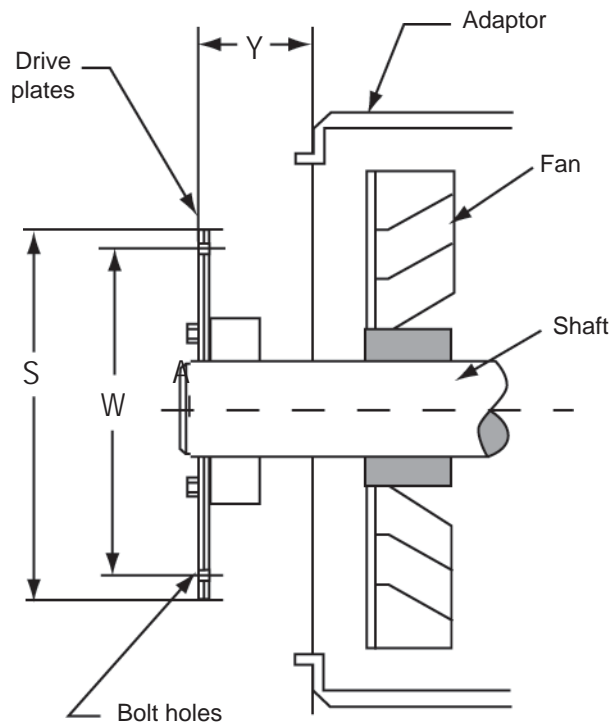

Figure 12: Single bearing generator drive plate and adaptor

Measure the axial distance from the machined surface on the engine flywheel housing the bottom of the flywheel drive disc recess (dimension G in Figure 13). Make sure the difference between dimensions Y (of Figure 12) and G are less than 1/32 inch. If G is more than Y, install additional spacers between the drive discs and the generator hub. If Y is more than G, remove spacers between the drive discs and generator hub.

Caution: The number and thickness of drive discs are specified for torque requirements. Do not remove drive discs to compensate for spacing.

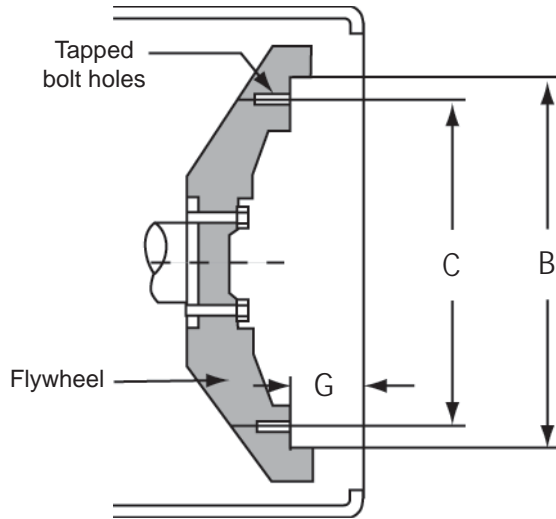

Figure 13: SAE flywheel and adapter

Install the generator to the engine. Make sure the drive discs seat in the recess of the flywheel housing. Secure the generator to the engine (drive discs to flywheel, adapter to flywheel housing), and the base. Use lock washers on all bolts. Torque the adapter and drive discs in a criss-cross pattern to the values in Table 3.

Ensure that the bolts in the flywheel do not bottom out. If they are too long or cannot be tightened with a socket or box wrench, use 1/4 to 3/8-inch long spacers inserted in the bolts as shown in Figure 14 to increase the clearance between the bolt head and the flywheel.

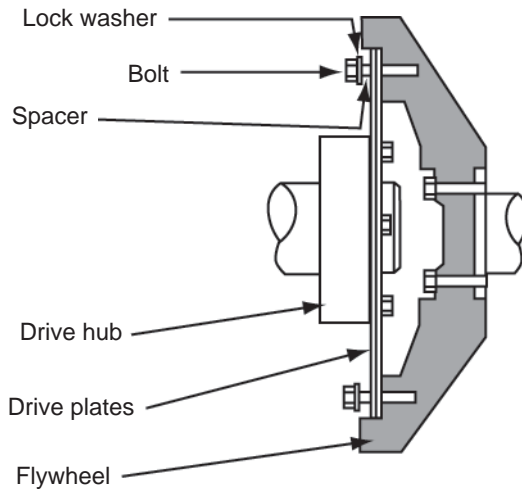

Figure 14: Disc-to-flywheel installation

Occasionally, there is insufficient clearance to install the bolts that fasten the drive discs to the engine flywheel, and the fan will have to be temporarily moved to accommodate this. This situation will typically occur with several types of generators:

- With the three-frame units that have an aluminum fan, loosen the fan hub bolts to move the fan. After installing the drive disc-to-flywheel bolts, move the fan back so the rotor-side edge is flush with the air opening and the minimum distance between the windings and the fan is 3/8 inch. Torque the fan hub bolts to 75 ft-lbs.
- With sheet metal fans with cast hubs that are in turn mounted on the drive hub, mark the drive hub as close as possible to the fan hub. Loosen the two set screws, the fan clamping bolt, and the fan bolts. Wedge the fan open, and move it out of the way (See Figure 15). After attaching the drive discs-to-fly wheel bolts, align the fan hub to the mark to move the fan back to its original position. Ensure the key is fully in place under the fan hub and positioned so the set screw will press on the key. Tighten the fan hub clamping bolt and the set screws. Install the fan bolts and torque them according to Table 3.

Note: The generator with sheet metal fans and cast fan hubs is shipped from the factory with the fan 1/2 to 3/4 inch from the fan baffle and clear of the inside adaptor for optimum air flow through the exhaust screen.

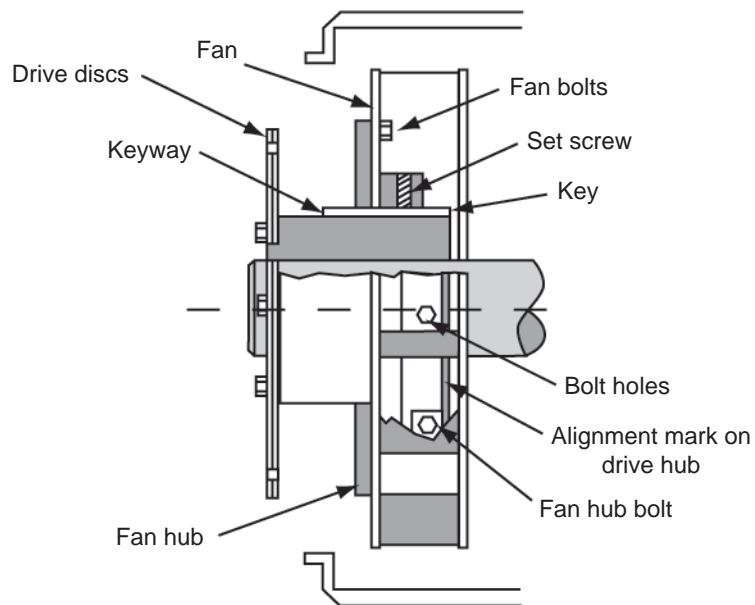

Figure 15: Moving sheet metal fans

After installing the drive disc-to-flywheel bolts, check the runout of the generator shaft by placing the base of a dial indicator on the generator frame and positioning of the probe on the shaft as shown in Figure 16. If the total indicated runout exceeds 0.003 inch, remove the drive discs bolts, and rotate the generator relative to the engine flywheel. Reinstall the bolts, and check the runout again.

Recheck the shaft-end-to-bearing-housing distance (dimension A in Figure 11).

Mount the brushless exciter armature assembly to the generator shaft (as described in the assembly procedures below).

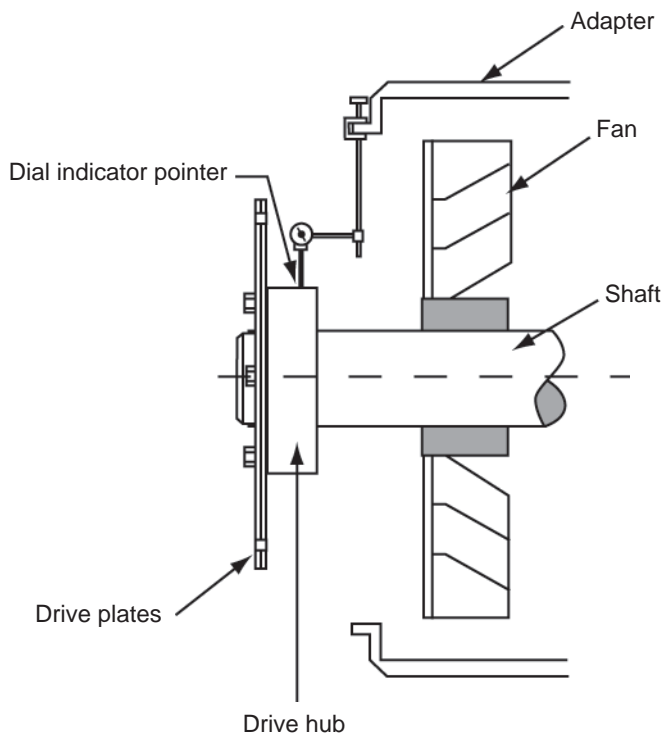

Figure 16 Runout check

Foot deflection

After alignment, check for foot deflection or “soft foot” condition on each shim location to eliminate distortion of the generator frame. Do this by loosening one mounting bolt at a time and checking deflection after retightening. Deflection at the shim location from shims under compression to a loosened condition must not exceed 0.003 inch.

Doweling

In case the mounting bolts loosen during operation, doweling will prevent movement of the generator. Dowel as follows:

Check the alignment after the generator has been in operation for at least 48 hours. If alignment is not satisfactory, realign.

Drill holes through the footpads and into the base in two mounting pads opposite each other. Drill the holes slightly smaller than the dowel pin.

Ream the holes to the proper diameter for the pin. Clean out chips, and install the pins.

Electrical connections

If the generator was subjected to a rapid change in temperature, freezing or wet conditions during shipment or storage, measure the insulation resistance of each winding and dry the generator, if necessary, as described in the maintenance section below.

Make all electrical connections (main load, temperature monitoring device, space heater, AVR) in accordance with local regulations and national/international electrical code requirements. Check the electrical diagrams provided with the generator or manual. The main terminals need to be properly spaced for the load connections. Refer to Table 3 for the proper torque values for the connections.

On larger generators grounding points are provided for properly grounding the system to the generator frame. The grounding wire must be sized to national/international code requirements.

Space heaters

When the generator has optional space heaters to prevent water condensation during long periods of downtime, connect the space heaters so they start when the generator is turned off and stop when the generator is switched on. Some generators with space heaters have thermostats. The thermostat should be set above the dewpoint. Refer to the electrical diagrams for the space heater characteristics.

Warning: *The space heaters are designed to be energized when the generator is shut down. They are hot enough to cause skin burns. Terminals for power at the space heaters are live during operation. Disconnect power to the space heaters before removing the generator covers.*

Inspection before startup

After electrical connections have been made, perform the following checks:

- Check all the connections to the electrical diagrams provided.
- Secure all covers and guards.
- Turn the rotor slowly with the appropriate starting mechanism (bar the engine or flywheel) through one revolution to see if the rotor turns freely.
- Check the bearings to see they are properly lubricated.
- Determine the direction of the engine rotation, and make sure that it matches the rotation of the generator.
- Make sure the power requirements comply with the data on the generator nameplate.
- Make sure that the engine-generator set is protected with an adequate engine governor and against excessive overspeed.
- Make sure the output of the generator is protected with an overload protection device, such as circuit breakers or fuses, sized in accordance with national/international electrical code and local electrical code standards. Fuses need to be sized using the lowest possible current rating above the full-load current rating (115% of rated current is commonly recommended).
- Remove tools and other items from the vicinity of the generator.

Caution: *Do not pry on the fan.*

Note: *For specific lubrication instructions, always refer to the bearing lubrication sheet that came with your manual or the lube plate on the generator.*

Operation

Initial startup: generators with both automatic and manual voltage control

1. Disconnect the generator output from the load by opening the main circuit breaker.
2. Turn the manual voltage adjust rheostat fully counterclockwise.
3. Put the auto-manual switch in the manual position.
4. Start the prime mover, and bring the set to rated speed. Turn the manual voltage adjust rheostat to reach rated voltage. Close the output circuit breaker, and apply load in steps until the rated load is reached. Adjust the manual adjust rheostat as necessary to obtain the desired output voltage.
5. Gradually reduce load, and adjust the rheostat accordingly until no load is reached. Open the circuit breaker, and stop the prime mover.
6. Actuate the auto voltage rheostat. Then start the genset, and bring it to rated speed. Adjust the voltage to the desired value.
7. Close the output circuit breaker. Then check the generator voltage and voltage regulation. Apply load in steps until the rated load is reached.
8. Check for vibration levels at no load and rated load. A slight increase is normal. As the load is maintained for 2-3 hours, the vibration levels will gradually increase and reach a final level.

Caution: Do not actuate the auto-manual switch with the full load applied to the generator. Whenever possible, stop the generator before switching.

Initial startup: Generators with automatic voltage control only (generator has an automatic voltage regulator (AVR) with no auto-manual switch)

1. Disconnect the generator output from the load by opening the main circuit breaker.
2. Turn the voltage adjust rheostat fully counterclockwise. Start the prime mover, and bring the set to rated speed. Turn the voltage adjust rheostat to obtain the desired voltage.
3. Close the output circuit breaker, and apply load in gradual steps until the rated load is reach. Note the voltage regulation with the changes in load steps.
4. Check for vibration levels at no load and rated load. A slight increase is normal. As the load is maintained for 2-3 hours, the vibration levels will gradually increase and reach a final level.

Restoring residual magnetism/field flashing

The direct current necessary to magnetize the revolving field is obtained from the exciter. Upon starting the generator, current and voltage is induced into the exciter by the magnetic lines of force set up by residual magnetism of the exciter field poles. Residual magnetism of the exciter field poles may be lost or weakened by a momentary reversal of the field connection, a strong neutralizing magnetic field from any source, or non-operation for a long time. If the generator fails to generate voltage after it has come up to rated speed, it may be necessary to restore residual magnetism.

To restore the small amount of residual magnetism necessary to begin the voltage build up, connect a 12 or 24-volt battery to the exciter field coil circuit and flash as follows:

1. Open the output circuit breaker, and stop the engine.
2. Disconnect the exciter field coil wires EF1 at the terminal EF1 and EF2 at the terminal EF2, and connect the battery positive lead to the field coil lead EF1.
3. Flash the field by touching the battery lead to the field coil circuit terminal EF2.
4. Disconnect the battery leads.
5. Reconnect the field coil lead EF1 to terminal EF1, and reconnect the field coil lead EF2 to terminal EF2.
6. Start the generator, and check for voltage build up. Reflash if the generator output voltage does not build up, or flash with the generator running, the field coil wires connected to the regulator, and a 3-amp or larger diode off the positive terminal of the battery per Figure 17.

Note: If the polarity of the exciter is reversed by flashing the field, it may be corrected by interchanging the battery leads.

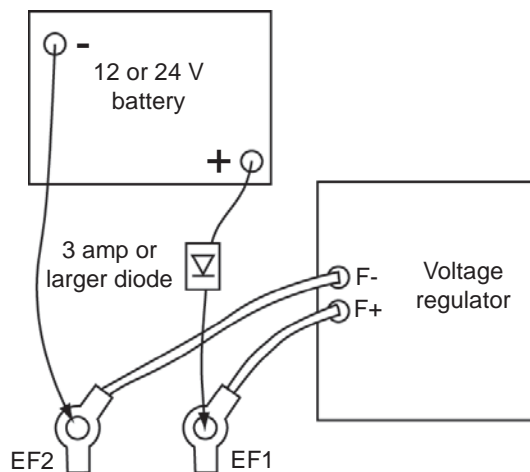

Figure 17: Field flashing setup with the field wires connected to the regulator

Caution: *Operating the unit beyond nameplate values may cause equipment damage or failure.*

Continuous operation

Operate the generator within the nameplate values . If the generator is operated below the rated power factor and voltage, decrease the kVA to prevent overheating of the field and stator windings. Consult the factory for derating factors if the application requires the unit to be operated beyond nameplate values.

Rotor overheating may occur when the generator is carrying excessive unbalanced loads. Negative sequence currents flowing in the field pole face cause the rotor heating. For a general guide to the allowable phase unbalance, see Figure 18, Guide to allowable phase unbalance (which is based on a 10% equivalent negative sequence current).

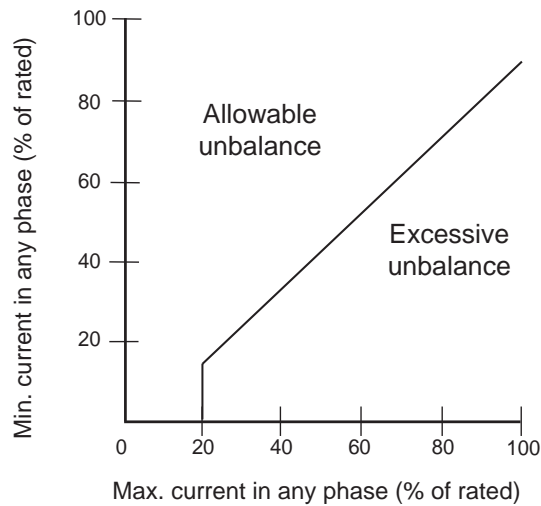

Figure 18: Guide to allowable phase unbalance

The guide is used in the following manner: Find the point where the vertical line (determined by the maximum current in any of the phases and expressed in percent of rated current) crosses the horizontal line (determined by the minimum current in any of the phases and expressed in percent of rated current). Ensure the point where these two lines intersect is within the permissible allowable unbalance region for safe operation of the generator.

Loss of field excitation can result in the unit operating out of synchronization with the system when operating is parallel. This has the effect of producing high currents in the rotor, which will cause damage very quickly. Protective relays should be considered to open the circuit breaker.

Idling

Unless the voltage regulator has V/Hz protection built in, having the generator set in operating mode while idling the engine can cause permanent equipment damage. If engine adjustments require that the engine be run at idle speed and the regulator does not have V/Hz protection, make the generator regulating system inoperative during idling by one of the following methods:

When the generator is provided with a voltage shutdown switch, be sure the switch is set to the idle position while the engine is running at idle speed.

Where the generator set is provided with field circuit breakers, set the circuit breaker to the off position while the generator is running at idle speed.

Where the generator set is provided with an automatic/manual control switch that has an off position, switch it to off while the engine is running at idle speed.

Where the generator set does not have any of the above options, remove the wires from the voltage regulator input power terminals when the engine is running at less than rated speed.

Parallel operation

For the generator to operate in parallel with a system in operation, the phase sequence of the generator must be the same as that of the system. Use transformers to reduce the voltage to an acceptable level, and then use a phase rotation meter or incandescent lamp method, described in electrical machinery handbooks, for a phase sequence check.

The output voltage at the paralleling point must be the same as each instant, which requires that the two voltages be of the same frequency, same magnitude, same rotation, and in coincidence with each other.

Voltmeters indicate whether the voltage magnitude is the same, and frequency meters indicate whether the frequencies are the same. Whether the voltages are in phase and exactly at the same frequency is indicated by a synchroscope or by synchronizing lamps.

A synchroscope can be used to indicate the difference in phase angle between the incoming machine and the system. The generator can be paralleled by using incandescent lamps connected as shown in Figure 19. The voltage rating of the series lamps must equal the voltage rating of the transformer-low voltage winding.

Each prime mover in the system must have the same speed regulating characteristics, and the governors must be adjusted to give the same speed regulation as determined by applying load that is proportional to the full load rating of the generator.

Caution: Refer to the voltage regulator manual for complete details and possible additional instructions. Damage to the rotating diodes, generator, and voltage regulator can be caused if the regulator is operated improperly.

Caution: Do not make connections or otherwise make contact with the generator leads or other devices connected to them unless the genset is stopped and the phase leads are grounded.

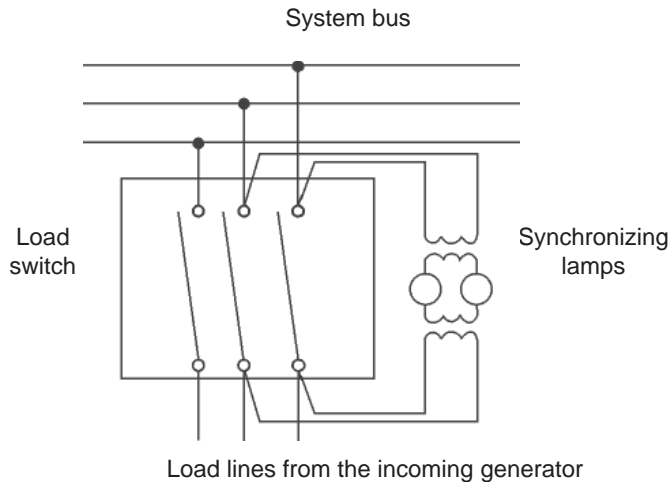

Figure 19: Synchronizing paralleled generators with test lamps

The voltage regulator must include paralleling circuitry. In addition, the voltage, droop settings and the V/Hz regulation characteristics must be the same for all the voltage regulators. This will allow the generators to properly share reactive loads.

If cross-current compensation is used, paralleling current transformers must give the same secondary current.

Current transformer secondary windings provide reactive kVA droop signal to the voltage regulator. Accidental reversal of this electrical wiring will cause the voltage to attempt to rise with load rather than droop. If this occurs during paralleling, stop the unit and reverse the wires at the voltage regulator terminals.

If the set is provided with a unit/parallel switch, set the switch to the parallel position on the unit being synchronized.

Synchronize the generator by adjusting the speed (frequency) slightly higher than the system. Observe the synchroscope or the lamps. The lamps should fluctuate from bright to dark at the rate of one cycle every 2 to 3 seconds. When the generator is in phase (the lights will be dark), close the circuit breaker. Immediately after closing the breaker, measure the line current kVAR of the generator. The readings must be within the rating of the unit. A high ammeter reading accompanied by a large kW reading indicates faulty governor control. A high ammeter reading accompanied by a large kVAR unbalance indicates problems with the voltage regulator. Adjusting the cross current or voltage droop rheostat should improve the sharing of kVAR.

To shut down the generator operating in parallel, gradually reduce the kW load by using the governor to reduce speed. When kW load and line current approach 0, open the generator circuit breaker. Operate the generator unloaded for several minutes to dissipate the heat in the windings. Refer to the prime mover manual for shutdown and cool-down procedures.

Maintenance

Warning: Do not service the generator or other electrical machinery without de-energizing and tagging the circuits as out of service. Dangerous voltages are present, which could cause serious or fatal shock.

Schedules

A regular preventive maintenance schedule will ensure peak performance, minimize breakdowns and maximize generator life. The schedule listed below is a guide for operating under standard conditions. Specific operating conditions may require reduced or increased maintenance intervals. Also, if there is a different or more specific schedule for your generator than the schedule provided below, it will be included as a supplement to the manual package.

Every day

Visually check generator bearing housings for any sign of oil seepage.

Check the operating temperatures of the generator stator windings.

Check the control panel voltmeter for proper stability and voltage output.

Monitor the power factor and generator loading during operation.

With generators that have sleeve oil bearings, check the operating temperatures and sight glass levels (if applicable).

Every week

Visually inspect the bearing exterior for dirt, and clean if necessary.

Inspect any generator air filters for build up of contaminants, and clean or replace as required

Every 2000 Hours or 6 months of operation

Remove generator outlet box cover. Visually inspect the stator output leads and insulation for cracking or damage. Check all exposed electrical connections for tightness. Check transformers, fuses, capacitors, and lightning arrestors for loose mounting or physical damage. Check all lead wires and electrical connections for proper clearance and spacing.

Clean the inside of the outlet box, air screens, bearing housings, and air baffles with compressed air and electrical solvent if needed.

With generators that have ball or roller bearings, check machine vibrations and bearing condition with a spectrum analyzer or shock pulse.

Regrease the regreaseable-type bearings. With generators that have sleeve oil bearings, inspect bearing oil for proper levels and clarity.

Note: For specific lubrication instructions, always refer to the bearing lubrication sheet that came with your manual or the lube plate on the generator.

Every 8000 hours or 1 year of operation

Check insulation resistance to ground on all generator windings, including the main rotating assembly, the main stator assembly, the exciter field and armature assemblies, and the optional PMG assembly.

Check the space heaters for proper operation.

Check the rotating rectifier connection tightness.

With generators that have sleeve oil bearings, replace the bearing oil.

Every 20,000 hours or 3 years of operation

With generators that have sleeve oil bearings, perform a sleeve bearing inspection to include the removal of the upper bearing housing and bearing liner to inspect the liner, shaft journal, and seal surfaces for wear or scoring.

Remove the endbrackets, and visually inspect the generator end windings for oil or dirt contamination. Excessive contamination may necessitate surface cleaning with compressed air and electrical solvent.

Inspect the fan and fan hub for damage.

Every 30,000 hours or 5 years of operation

(Contact Kato Engineering for assistance)

Disassemble the generator (this includes rotor removal).

Clean the generator windings using either (depending upon the severity of contamination) 1) compressed air and electrical solvent or 2) de-greaser and high pressure hot water wash. Dry the windings to acceptable resistance levels (see the dry out procedure).

Inspect the rotor shaft bearing journals for wear or scoring.

With generators that have ball or roller bearings, replace the bearings.

With generators that have sleeve bearings, replace the bearing liners and oil seals.

Maintenance procedures

Visual inspection methods of windings

Electric machines and their insulation systems are subjected to mechanical, electrical, thermal and environmental stresses that give rise to many deteriorating influences. The most significant of these are the following:

Thermal aging: This is the normal service temperature deteriorating influence on insulation.

Over temperature: This is the unusually high temperature of operation caused by conditions such as overload, high ambient temperature, restricted ventilation, foreign materials deposited on windings, and winding faults.

Overvoltage: This is an abnormal voltage higher than the normal service voltage, such as caused by switching or lightning surges or non-linear loads. Operating above rated nameplate voltage will reduce insulation life.

Contamination: This deteriorates electrical insulation by 1) conducting current over insulated surfaces 2) by attacking the material to reduce electrical insulation quality or physical strength, or by 3) thermally insulating the material so the generator operates at higher than normal temperatures. Such contaminants include water or extreme humidity, oil or grease including unstable anti-wear and extreme pressure lubricants, conducting and non-conducting dusts and particles, industrial chemicals such as acids, solvents, and cleaning solutions.

Physical damage: This contributes to electrical insulation failure by opening leakage paths through the insulation. Physical damages can be caused by physical shock, vibration, over-speed, short-circuit forces or line starting, out-of-phase paralleling, erosion by foreign matter, damage by foreign objects and thermal cycling.

Ionization effects: Ionization (corona), which may occur at higher operating voltages, is accompanied by several undesirable effects such as chemical action, heating, and erosion.

To achieve maximum effectiveness, a direct visual inspection program initially to those areas that are prone to damage or degradation caused by the influences listed above. The most suspect areas for deterioration or damage are 1) ground insulation, which is insulation intended to isolate the current carrying components from the non-current bearing components, and 2) support insulation, which includes blocks and slot wedges and are usually made from compressed laminates of fibrous materials, polyester, or similar felt pads impregnated with various types of bonding agents. Check for the following:

Deterioration or degradation of insulation from thermal aging:

Examination of coils reveal general puffiness, swelling into ventilation ducts, or a lack of firmness of the insulation, suggesting a loss of bond with consequent separation of the insulation layers from themselves or from the winding conductors or turns.

Abrasion: Abrasion or contamination from other sources, such as chemicals and abrasive or conducting substances, may damage coil and connection surfaces.

Cracking: Cracking or abrasion of insulation may result from prolonged or abnormal mechanical stress. In stator windings, looseness of the bracing structure is a certain sign of such phenomena and can itself cause further mechanical or electrical damage if allowed to go unchecked.

Erosion: Foreign substances impinging against coil insulation surfaces may cause erosion.

Cleaning

Warning: *When using cleaning solvents, ensure adequate ventilation and user protection.*

Exterior: Wipe loose dirt from the exterior with a clean, lint-free cloth. Remove stubborn accumulations of dirt with a detergent or solvent that won't damage the paint or metal surfaces. Use a vacuum to clean ventilating ports.

Windings, assembled machines: Where cleaning is required at the installation site and complete disassembly of the machine is unnecessary or not feasible, pick up dry dirt, dust or carbon with a vacuum cleaner to prevent the redistribution of the contaminant. A small non-conducting nozzle or tube connected to the vacuum cleaner may be required to reach dusty surfaces or to enter into narrow openings. After most of the dust has been removed, a small brush can be affixed to the vacuum nozzle to loosen and allow removal of dirt that is more firmly attached.

After the initial cleaning with a vacuum, compressed air may be used to remove the remaining dust and dirt. Compressed air used for cleaning must be clean and free of moisture or oil. Air pressure or velocity must be adequately controlled to prevent mechanical damage to the insulation. Disassembly of the machine and more effective cleaning by a qualified Kato technician may be required if the above described field service cleaning procedures do not yield effective results.

Windings, disassembled machines: Take an initial insulation resistance reading on the machine to check electrical integrity. The high pressure hot water wash method of cleaning, which sprays a high velocity jet of hot water and water containing a mild detergent, is normally effective in cleaning windings, including those subjected to flooding or salt contamination. Use multiple sprays with clean water to remove or dilute the detergent following the detergent spray. Dry the machine until acceptable insulation resistance values are obtained at room temperature. See the insulation resistance procedures below for minimum recommended values.

Electrical contacts: Clean electrical contacts, switch contacts and terminals with an approved contact cleaner. Do not file contacts.

Insulation resistance tests at low voltage

Insulation tests are conducted for two reasons: to discern existing weakness or faults or to give some indication of expected service reliability. Insulation resistance tests should also be conducted when the unit is subjected to excessive moisture or dirt.

Insulation resistance tests are based on determining the current through the insulation and across the surface when a DC voltage is applied. The leakage current is dependent upon the voltage and time of application, the area and thickness of the insulation, and the temperature and humidity conditions during the test.

The insulation resistance test is used to determine the insulation condition prior to application of more extensive testing measures. Refer to the following electrical measurement procedures for testing detail. Contact Kato Engineering or refer to IEEE Standard. 432-1992 when more extensive insulation tests are required.

Exciter field (stator) and PMG armature (stator)

1. Disconnect the exciter leads from the terminals in the terminal box or the voltage regulator.
2. Connect exciter leads to one clamp of 500-volt megger, and connect the other clamp to the generator frame.
3. Apply 500 V from the megger, and measure the resistance reading after 1 minute. The reading must be a minimum of 50 megohm. If it is not, refer to the cleaning or dry out procedures.
4. Ground the exciter field leads to the generator frame for several minutes after the megger has been disconnected. This will allow the voltage build up to be properly discharged.

Exciter armature

1. Disconnect the exciter armature leads from the rotating rectifiers.
2. Connect the leads of the exciter armature to one clamp of a 500-volt megger, and connect the other clamp to a suitable connection on the shaft.

Note: New generators should measure about 100 megohms of insulation resistance when meggered. Generators that read 50 megohms or less should be dried out according to the dry out procedures here. Generators with insulation resistance readings of 10 megohms or less must be cleaned and then dried out.

Winding Temp (°C)	Conversion factor
10	0.23
20	0.37
30	0.6
40	1
50	1.7
60	2.7
70	4.5
80	7.5
90	14
100	23
110	38
120	61

Table 4: Temperature conversion factor for resistance readings

Warning: *Never apply the megger to the rotating rectifier, the voltage regulator, or generator accessories (e.g., temperature detectors, space heaters).*

Caution: *The insulation resistance tests are usually made on all or parts of an armature or field circuit to ground. They primarily indicate the degree of contamination of the insulating surfaces or solid insulation by moisture and other conducting influences and will not usually reveal complete or uncontaminated ruptures.*

Note: *The insulation resistance value increases with decreasing winding temperatures. All readings should be corrected to a reference winding temperature of 40° C. Use Table 4 for converting megger readings to other temperatures (e.g., 100 megohms at 50° C is converted to 170 megohms: 1.7 x 100) at 40° C).*

3. Apply 500 V from the megger, and measure the resistance reading after 1 minute. The reading must be a minimum of 50 megohm. If it is not, refer to the cleaning or dry out procedures.
4. Ground the exciter leads to the shaft after disconnecting the megger. This will allow the voltage build up to be properly discharged.

Main rotor

1. Disconnect the generator field leads from the positive and negative terminals of the rotating rectifier assembly.
2. Connect the positive and negative leads to one clamp of the 500-volt megger, and connect the other clamp to the shaft.
3. Apply 500 V from the megger, and measure the resistance reading after 1 minute. The reading must be a minimum of 50 megohm. If it is not, refer to the cleaning or dry out procedures.
4. Ground the field leads to the shaft after disconnecting the megger. This will allow the voltage build up to be properly discharged.

Main stator

1. Disconnect power connections and all control apparatus from the generator terminals.
2. Measure insulation resistance of each phase separately with the two other phases shorted to the frame.
3. Use a 500-volt megger connected between the lead(s) of the phase to be measured and generator frame. The minimum 1-minute insulation resistance must not be less than 50 megohm.
4. Ground the leads to the frame after the 1-minute megger test. This will allow the voltage build up to be properly discharged.

Dry out procedures

If the insulation resistance readings are below the recommended minimum values specified previously, use one of the dry out procedures described below. Select the procedure based on the size and location of the unit, available equipment, and experience of personnel. Before drying, remove the voltage regulator, and cover all inlet and discharge openings. Provide an opening at the top of the machine, preferably at the fan end, for moisture to evaporate.

Drying with external heat: Place heat lamps, space heaters (in addition to the ones already supplied) or a steam pipe near the windings. Monitor winding temperatures. Raise winding temperature gradually at a rate of 50° F (28° C) per hour up to 200° F (93° C). Measure insulation resistance at 1-hour intervals. Typically the insulation resistance will slowly drop while the temperature is coming up, and then gradually increase and level out.

Drying with AC current in the armature: Short circuit the generator terminals. Provide DC excitation to the brushless exciter field winding. Insert a current transformer and an ammeter to read full load current. Run the generator at rated speed. Apply excitation to the exciter field until rated current is developed. Monitor winding temperatures until they stabilize. Continue running until insulation resistance values level off. Monitor winding temperatures. Raise winding temperature gradually at a rate of 50° F (28° C) per hour up to 200° F (93° C). Measure insulation resistance at 1-hour intervals. Typically, the insulation resistance will slowly drop while the temperature is coming up and then gradually increase and level out.

Bearing lubrication

Shielded or sealed ball bearings: Shielded or sealed ball bearings are factory packed with lubricants and generally can be operated several years without requiring replenishment or change of the grease. If repacking the grease is necessary, disassemble the machine, clean the bearings, and repack the bearings about 1/2 full using a high quality ball bearing grease, which must be capable of lubricating satisfactorily over a temperature range of the lowest ambient temperature to 250° F (121° C).

Regreaseable ball or roller bearings: In applications where regreaseable bearings are used, grease fill fittings and relief valves are incorporated into the bearing housing. Lubricate the bearings in accordance with the lubricating instructions attached to the generator.

Sleeve bearings: Lubricate the bearings in accordance with the lubricating instructions attached to the generator and the bearing lubrication instructions, which are provided in the manual package as supplementary material.

Caution: Do not apply heat too rapidly. It could damage the windings.

Note: For specific lubrication instructions, always refer to the bearing lubrication sheet that came with your manual or the lube plate on the generator.

Rectifier tests

If a failure of a rectifier is suspected, remove the exciter cover. Remove the nut and washer holding the rectifier in the heat sink, and remove the diode lead wire. Lift the rectifier from the heat sink (see figure 20 for an overview). Test the entire rectifier with an ohmmeter or test lamp as follows:

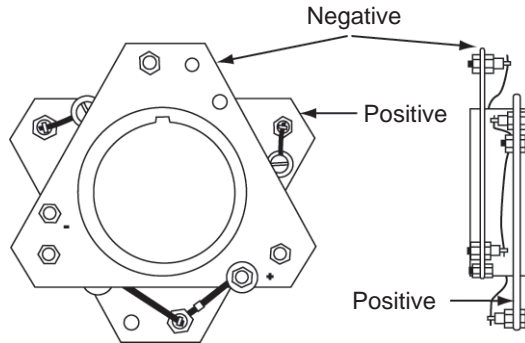

Figure 20: Rectifier

Ohmmeter: Connect the ohmmeter leads across the rectifier in one direction (see Figure 21). Note the meter reading. Reverse the leads, and note the meter reading. The meter should indicate a low resistance when the leads are across the rectifier in one direction and a high resistance when the leads are across the rectifier in the opposite direction. A low resistance in both directions indicates a short. A high resistance in both directions indicates an open rectifier.

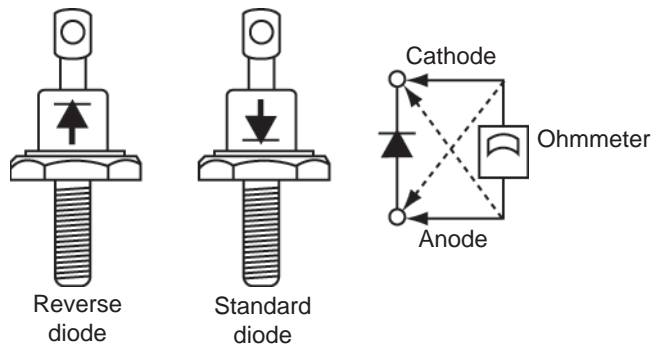

Figure 21: Testing the rotating rectifier with an ohmmeter

Test lamp: Connect the leads of a test lamp, consisting of standard flashlight batteries and a flashlight and built, as shown in Figure 22, across the rectifier in one direction. Then reverse the leads. The light should light in one direction but not the other. If the light lights in both directions, the rectifier is shorted. If the light does not light in either direction, the rectifier is open.

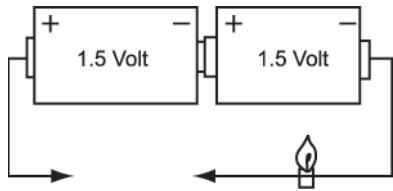

Figure 22 Test lamp

Replace defective rectifiers with rectifiers of the same operating characteristics as rectifiers installed in the generator at the factory. Order rectifiers by part number, including the model and type of exciter as well as the generator serial number.

Surge protectors may be included on the rotating rectifier assembly. Disconnect one lead of the surge protector, and connect the leads of an ohmmeter or makeshift test lamp, consisting of standard flashlight batteries and a flashlight and built as shown in Figure 21, across the surge protector in either direction.. If the light comes on, the surge protector is defective. Order surge protectors by part number, including the model and type of exciter as well as the generator serial number. Following replacement, make sure that the revolving field, exciter armature, and rotating diode leads are properly secured.

Note: *The following procedures are meant to be a general guide. Procedures for your unit may vary.*

Warning: *Ensure the generator has stopped and is de-energized before disassembly.*

Warning: *Use a hoist and slings or chains to support components during removal. Use lifting devices that are selected for generator component weights. Be extremely careful not to damage components.*

Warning: *Make sure the pipe is strong enough to support the weight of the rotor and that it does not have rough edges on the inside, which could damage the shaft.*

Caution: *To prevent tension on the shaft, put the slings around the largest shaft step possible.*

Caution: *Make sure the rotor does not rest on the stator during the stages of movement. Make sure the rotor does not hit the stator.*

Disassembly

Overall disassembly

1. Remove the terminal box cover, and disconnect the load leads and all other leads. Tag the leads to ensure they are correctly connected when the generator is reassembled.
2. Remove the bolts securing the generator to the base and prime mover, and move the generator to an area that allows sufficient room for disassembly.
3. Remove the coupling or drive plates.
4. Remove the exciter cover.
5. Remove the clips securing the exciter field leads to the exciter frame and endbracket. Disconnect the leads and remove the exciter frame/stator and/or exciter-PMG frame/stator.
6. Remove the (optional) PMG and exciter armature as described below.
7. Support the shaft. Remove the exciter-end endbracket bolts, and remove the endbracket. Tap lightly with a rubber or fiber mallet to loosen the endbracket if necessary. Repeat with the drive-end endbracket (if applicable).
8. Remove the fan from the hub where applicable. If necessary, make sure to mark the location of the fan for reinstallation.
9. Float out the rotor (see Figure 23). First attach a pipe over the shaft on the drive end. Attach slings around the pipe on one end and around the shaft on the opposite end. Lift up the rotor, and move it out, resting the rotor as the slings are moved down the pipe for the next lifting stage.

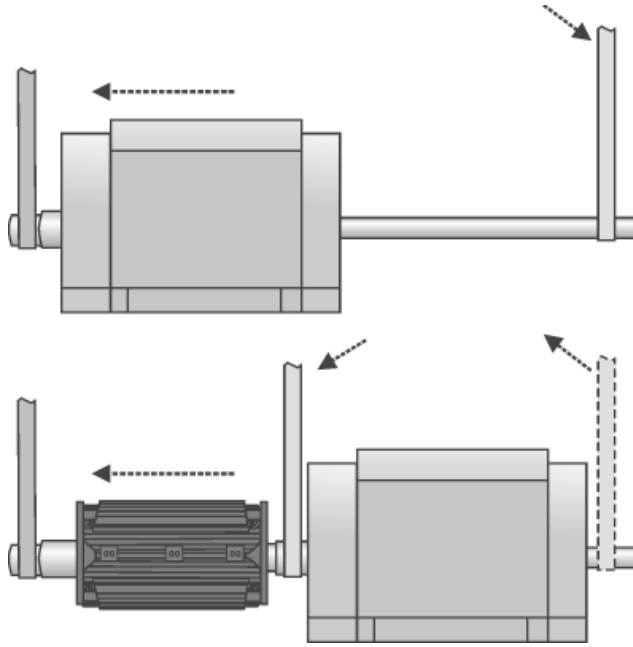

Figure 23: Floating the rotor

Exciter armature and PMG removal (see Figure 24)

1. Remove the exciter cover.
2. Remove the retaining bolt and washer.
3. Disconnect the field wires on the rotating rectifier assembly.
4. If the generator has a PMG rotor, pull it off separately using hand force. Wrap the PMG rotor in plastic to avoid contamination with metal filings. Note: Some inboard PMG assemblies use a locknut to secure the PMG rotor. See figure 26. To remove the PMG rotor with a lock nut:
 - a) On the lockwasher, pry up the tab that is bent down in a notch of the locknut. Then unscrew the locknut with a spanner wrench, and remove the lockwasher.
 - b) Pull the PMG rotor straight back. Take care not to cock the PMA when pulling it off.
 - c) Wrap the PMG rotor in plastic to avoid contamination with metal filings.
5. Slowly pull the armature assembly off of the generator shaft. If the exciter can not be pulled off by hand, use a hydraulic jack as shown in Figure 25.
6. Remove the key from the keyway in the generator shaft.

Caution: Ensure the generator field wires are flat in the wireway so they don't tear during pulling. Do not pull on the edges of the heat sinks or on the exciter armature windings.

Warning: Pull the PMG off straightly. The assembly may pull toward other steel components. Be careful that your fingers or hands do not get pinched.

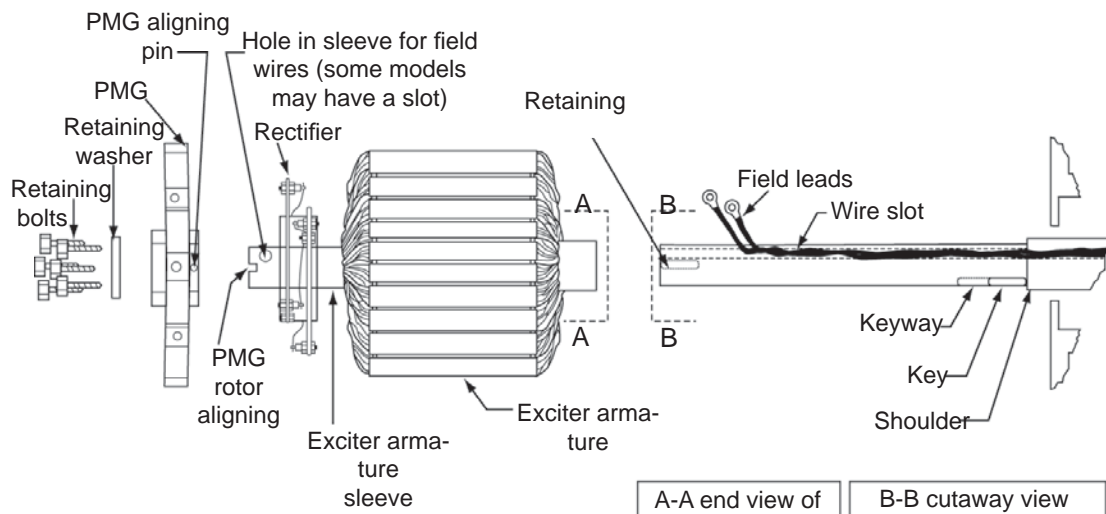

Figure 24: Exciter armature assembly

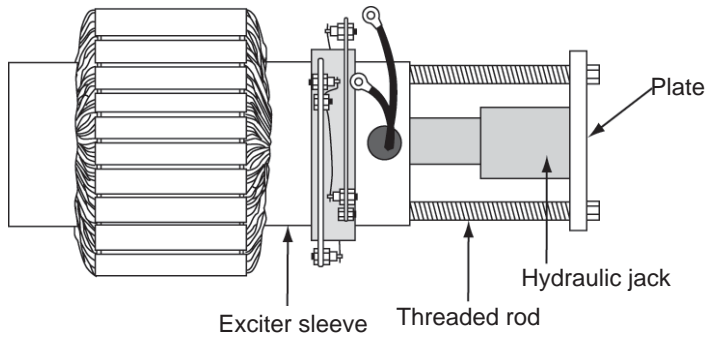
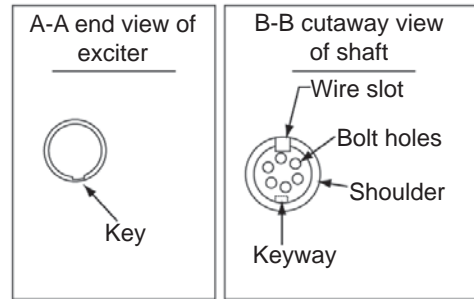

Figure 25: Pulling the armature assembly

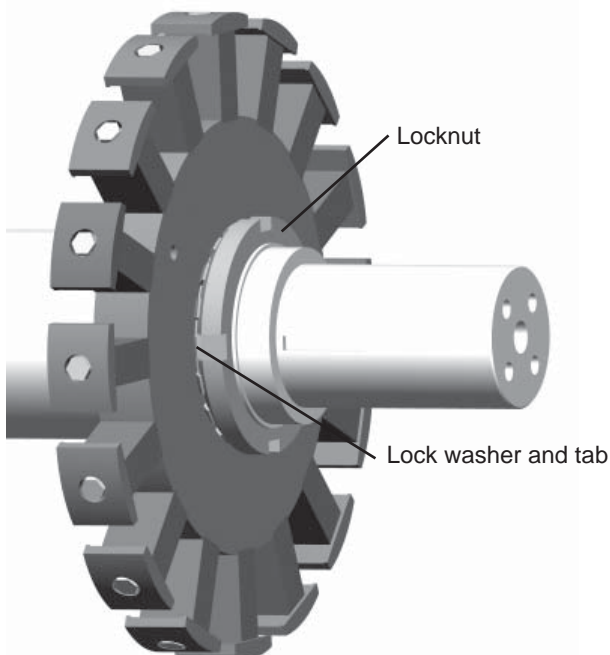

Figure 26: PMG rotor with locking nut

Bearing removal

1. Remove the endbracket(s) to expose the bearing(s).
2. Use a puller to remove the bearing from the shaft end with a cap. If the bearing is going to be used again, make sure the puller supplies pressure only against the bearing inner ring (see Figure 26).

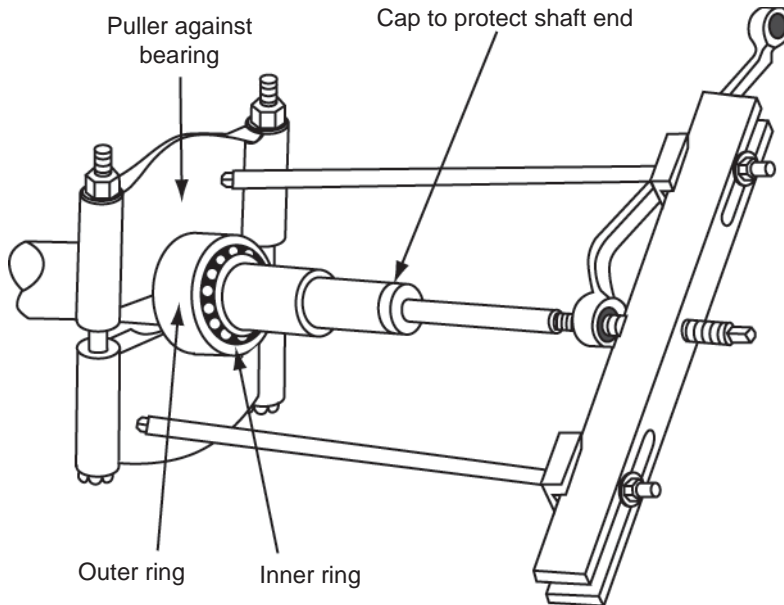

Figure 27: Pulling the bearing

Assembly

Bearing installation (done prior to installing the rotor)

1. Heat the bearing to 220° F (104° C) - 250° F (121° C) in a clean oven or with an induction heater.
2. Start the heated bearing on the shaft. Then use a fiber or soft metal tube to tap the bearing into place.
3. Ensuring that pressure is applied only to the bearing inner ring, press the bearing onto the shaft until the inner ring seats against the bearing shoulder on the shaft. Assemble the rest of the generator after the bearing has cooled.

Caution: Make sure all components are clean before assembly.

Note: Torque fasteners to the values specified in Table 3 unless otherwise specified.

Overall assembly

1. Float in the rotor until the rotor and stator laminations line up. Position the rotor such that a full pole face is at the bottom.
2. Install the endbrackets. Support the rotor during installation. Put an corrosion inhibitor on the bare mating surfaces to prevent rust.
3. Install the exciter armature and optional PMG as described below.
4. Install the covers.
5. Install the coupling or drive plates.
6. Reconnect the load leads and exciter leads.

Exciter armature and PMG installation (see Figure 24)

1. Clean the shaft and inside of the exciter sleeve.
2. Place the key in the slot in the shaft.
3. Lay the generator field wires flat in the wireway with the wire ends protruding past the end of the shaft.
4. Position the exciter armature assembly in line with the shaft, and turn the assembly to the position where the keyway in the exciter sleeve is in line with the key in the generator shaft.
5. With hand force, push the exciter armature assembly over the shaft, so the end of the sleeve is against the shoulder on the shaft. When it is part of the way onto the shaft, start the field lead wires through the wire hole or slot in the exciter sleeve. It may be necessary to tap lightly on the exciter sleeve in order to move the assembly over the key. Use a fiber or rubber mallet. If installation is still a problem, use a heat gun to expand the exciter sleeve.
6. Connect the exciter armature wires to the rectifier terminals.
7. If the generator has a PMG, place it onto the end of the exciter sleeve. Make sure it is aligned with the pin slot in the end of the exciter sleeve.
8. Install the retaining washer and bolt, and torque (60 ft-lbs for a 1/2-inch diameter bolt; 200 ft-lbs for a 3/4-inch diameter bolt).
9. Install the exciter frame/stator and/or exciter-PMG frame/stator. Install the clips securing the exciter field leads to the exciter frame and endbracket and connect the leads.

Caution: *Do not pound on the rectifier or armature windings.*

10. Measure the air gap between the exciter armature and exciter field and between the PMG rotor and PMG stator. If the air gap of the armature is less than specified in Table 5 or if the air gap of the PMG is less than 0.020 inch, check 1) generator-engine alignment, 2) check for bearing wear, 3) check for misalignment of the armature, PMG or stator.

Exciter armature diameter (in.)	Minimum air gap (in.)
5 3/4	0.014
9 7/8	0.014
12 1/2	0.018
16 1/4	0.035

Table 5: Exciter air gap

11. Install the exciter cover.

Storage

If the generator is not installed in its operating location as soon as received, store it in a clean, dry area, not subject to vibrations or sudden temperature or humidity changes. Make sure the storage area temperature is between 10° F (-12° C) and 120° F (49° C) and the relative humidity is less than 60%. If possible, storage should be in an ambient temperature of approximately normal room temperature. Protect the shaft from corrosion by applying an anti-corrosion agent. Cover the unit with a durable cover.

Prepare units that cannot be stored in a temperature and humidity controlled area as follows:

Install desiccant bags in the exciter cover and inside the end bells.

Vacuum seal the unit in a covering of plastic or other material designed for that purpose.

Adequately tag the generator to ensure that preservative greases and desiccant bags are removed before the unit is placed in operation.

If space heaters are supplied, energize them to keep condensation from the windings.

For storage longer than 2 months, rotate the shaft a minimum of 10 revolutions every 60 days.

When the unit is taken out of storage, check the insulation resistance on all windings. (See the maintenance section).

Note: To measure air gap, measure completely around the gap between the exciter armature and exciter field with a feeler gauge. Keep the gauge at the tightest point, and turn the generator over to measure the air gap as the rotor turns.

Caution: Do not pry on the fan.

Warning: If necessary, remove the covers around the space heaters to reduce the risk of fire.

Caution: Grease used in ball and roller bearing generators is subject to time deterioration. Before placing the unit into service after long-term storage, check the bearings for corrosion, and replace the grease.

Troubleshooting Guide (corrective maintenance)

Between regular preventive maintenance inspections, be alert for any signs of trouble. Correct any trouble immediately. See Table 6 for symptoms, causes and remedies.

Warning: *Problems left uncorrected can result in injury or serious damage, which can result in costly repairs and downtime.*

Symptom	Cause	Remedy
No Voltage	Open voltage regulator, circuit breaker or fuses	Check. Reset the circuit breaker or replace fuses if open.
	Overvoltage, undervoltage, or overload devices tripped (when protective devices are incorporated into the circuit)	Check for the cause of the abnormal condition. Correct any deficiencies. Reset devices. Check the generator nameplate for nominal operating values.
	Open circuit in exciter field	Check continuity of shunt field and leads to voltage control. (Use ohmmeter or wheatstone bridge) If open in field coils, remove exciter field assembly and return assembly to factory for repair.
	Loss of residual magnetism in exciter field poles	Restore residual magnetism or flash field. When the voltage regulator is a model that requires flashing, install an automatic field flashing system.
	Open circuit in stator windings	Check for continuity in the windings. Return the generator to the factory for repair if open.
	Malfunction of automatic voltage regulator	See troubleshooting of voltage regulator. Correct deficiencies.
	Short-circuited generator output leads	Clear lead to restore voltage buildup.
	Open in rotating rectifiers	Check rotating rectifiers, and replace if open.
	Open in generator field	Check for continuity and return rotor to factory for repair if field coils are open.
	Shorted or grounded surge protector	Check for shorts or grounds. Replace .
	Shorted or grounded rotating rectifier	Check for shorts grounds. Replace or repair.
	Shorted or grounded exciter armature	Check for shorts or grounds. Replace or repair.
Low voltage	Shorted leads between the exciter armature and generator field	Test and repair.
	Incorrect stator connections	Check the connections, and reconnect

Symptom	Cause	Remedy
Low voltage (cont.)	Improper adjustment of voltage adjust rheostat	Adjust rheostat.
	Excessive load	Reduce load. With three-wire, single-phase and four-wire, three-phase generators, the load on each leg must be as evenly balanced as possible and must not exceed the rated current on any leg.
	Line loss	Increase the size of the line wire.
	High resistance connections (hot)	Make better connections.
	Shorted main or exciter field	Test the field coils for possible short by checking resistance with an ohmmeter or resistance bridge. Return the rotor assembly to the factory for repair if field coils are shorted.
	Low power factor	Reduce inductive (motor) load. Some AC motors draw approximately the same current regardless of load. Do not use motors of larger horsepower rating than is necessary to carry the mechanical load.
	Weak field due to operating in a warm temperature	Improve the ventilation of the generator. Field current can be increased providing the generator temperature rating stamped on the nameplate is not exceeded.
	Defective rectifiers in rectifier assembly (stationary)	Check rectifier assembly. Replace defective fuses or rectifiers.
	Excessive load	Reduce load to rated value.
	Defective bearing	Replace the bearing.
	Improper speed of engine driven generator set due to defective governor, ignition system, or carburetor	Check and correct deficiencies.
Fluctuating voltage	Voltage regulator not operating properly	Check the regulator. Adjust, repair or replace.
	Prime mover speed fluctuating	Check frequency and voltage of incoming power when the generator set is motor driven. Check engine governor on engine-driven generator sets.
	Loose internal or load connections	Tighten all connections.
	Generator overloaded	Reduce load to rated value.
	DC excitation voltage fluctuating	Trace DC excitation circuit. Correct any defects.
	Overspeed	Correct speed of prime mover.
High voltage	Voltage regulator not operating properly	Check the regulator. Adjust, repair or replace.
	Improper adjustment of voltage adjust rheostat or voltage regulator	Adjust rheostat and/or voltage regulator.

Symptom	Cause	Remedy
Overheating	Clogged ventilating screens and air passages	Clean all screens and air passages.
	Dry or defective bearings	Replace defective bearings.
	Coupling misaligned	Align the generator set.
	Generator field coils shorted or grounded	Test field coils for shorts. Replace shorted rotor or return it to the factory for repair.
	Unbalanced load or overload, low PF	Adjust load to nameplate rating.
Vibrations	Defective or dry bearings	Replace defective bearings.
	Misalignment of generator and prime mover	Align the generator set.
	Generator not properly mounted	Check mounting. Correct defective mounting.
	Transfer of vibration from another source	Isolate the generator set from the source of vibration by installing vibration dampeners between generator set base and foundation.

Table 6: Troubleshooting

Appendices

List of equipment required for installation and maintenance:

Test equipment

Ammeter
Multimeter
Thermometer
Megger
Resistive Bridge

Notes

Clamp-on, 0 to 500 amp range for measuring of electrical current.
Digital, for measuring voltage, current, frequency and resistance.
For measuring temperature in Celsius
To measure insulation resistance.
To measure resistance of windings.

Special tools

Bearing puller
Exciter puller

For changing bearing.
For pulling exciter armature

Standard tools

Cable tool
Flashlight
Grease gun
Hammer
Lamp (incandescent)
Screwdrivers
Screwdrivers
Wrench
Wrench
Wrench set
Wrench set
Wrench set
Vacuum

Crimping
As required
For lubricating bearings
Soft-faced
Safety light
Standard, sized as required
Phillips, sized as required
Adjustable, 12-inch
Torque 0 to 100 ft-lb
Allen, 1/8 to 1/2 inch
Socket, 1/4 to 1 Inch with 3/8 and 1/2 inch drive
Standard, open-end/box-end combination sized 1/4 to 1 inch
Electric with nonmetallic nozzle

Materials

Air
Corrosion inhibitor
Covering material

Compressed, dry.
Nox-Rust VC #10 Oil or equivalent
Waterproof desiccant bags for protection from moisture during long-term equipment storage

Detergent
Gloves
Gloves
Heaters

As required for cleaning
Chemical-protective
Electrical-protective
Space Heater, for eliminating excess moisture in damp areas and dry out of motor or generator windings

Plastic
Rags
Water
Tags

Protection for long-term storage
As required for cleaning
Warm and clean, for cleaning
Warning and cautions

Main part location

