

# INSTRUCTION MANUAL

## SINGLE BEARING KAMAG GENERATOR WITH OUTBOARD EXCITER

SERIAL NUMBER

---

### INCLUDES

PRINCIPLES OF OPERATION  
INSTALLATION INSTRUCTIONS  
ADJUSTMENT AND OPERATING INSTRUCTIONS  
MAINTENANCE AND TROUBLESHOOTING  
DRAWINGS AND GENERAL INFORMATION

**Kato Engineering**

---



P.O. BOX 8447  
MANKATO, MN 56002-8447  
(507) 625-4011  
FAX (507) 345-2798

## **Safety Summary**

### **WARNING**

This equipment contains high speed (1800 RPM) rotating parts and develops lethal voltage (480 VAC or higher). Stop generator set before removing protective covers for the purpose of making electrical connections, installation, adjustments, inspection, troubleshooting, testing, repair, or parts replacement. Install protective covers before starting the generator set. Failure to observe this precaution can result in serious injury or electrocution.

### **WARNING**

Where meters or test instruments are used for purpose of troubleshooting and testing, it is recommended the test equipment be placed external to the generator and the generator set be stopped while making or removing meter and instrument connections. Be sure protective covers are installed before running unit. Failure to observe this precaution can result in serious injury or electrocution.

### **WARNING**

Do not lift complete generator set by means of lifting eye on generator. Disregarding these instructions may result in serious injury or equipment damage.

### **WARNING**

Do not lift or pry on generator fan. Failure to observe this precaution can result in serious injury and equipment damage.

### **WARNING**

Make certain that sufficient clearance exists between fan and stationary parts and make certain fan and fan hub bolts are torqued. Failure to observe this precaution can result in serious injury and equipment damage.

### **WARNING**

When circuit breakers are not included with the generator, the terminals on the ends of the stator lead wires are not insulated. These terminals must be insulated before generator set is operated. Failure to observe this precaution can result in serious injury and equipment damage.

### **CAUTION**

Do not attempt to lift or transport any single bearing generator without proper rotor support. Failure to observe this precaution can result in extensive equipment damage. Make certain exciter rotor is removed while handling generator.

### **CAUTION**

Do not push on rotating rectifier or exciter winding. Failure to observe this precaution can result in equipment damage.

Publication No.: **350-04001-00A**

Publication Date: **August 1985**

Supersedes: **350-04001-00, August 1981**

# Table of Contents

## Section 1

### General Information, Principles of Operation and Mechanical Construction

GENERAL .....	1-1
PRINCIPLES OF OPERATION .....	1-1
MECHANICAL CONSTRUCTION .....	1-1
Generator Frame and Stator .....	1-1
Generator Frame Cover .....	1-1
Generator Rotor Assembly .....	1-2
A. Shaft	
B. Generator Field Poles	
C. Air Circulating Fan	
D. Bearings	
Exciter Rotor .....	1-2
A. Exciter Armature	
B. Rectifier	
Exciter Field Assembly .....	1-3
Endbell .....	1-3
Adapter .....	1-3
Terminal Box .....	1-3

## Section 2

### Receiving, Inspection, Handling Instructions, and Storage

RECEIVING YOUR KAMAG GENERATOR .....	2-1
WINDING INSPECTION .....	2-1
UNPACKING .....	2-1
STORAGE .....	2-1

## Section 3

### Coupling and Aligning Generator and Prime Mover

GENERAL .....	3-1
PRE-COUPLING MEASUREMENTS .....	3-1
A. Engine Crankshaft and Flywheel Deflection	
B. Measuring Generator Drive Plate and Flywheel Driving Ring Pilot Bore	
C. Checking Exciter Alignment	
D. Checking Bearing Endclearance	
COUPLING AND MOUNTING GENERATOR ONTO ENGINE AND BASE .....	3-2
MEASURING GENERATOR ROTOR ECCENTRICITY .....	3-4
MEASURING ROTOR ANGULAR ALIGNMENT .....	3-5

## Section 4

### Electrical Connections

GENERAL .....	4-1
A. Three-Phase Wye Connected Generator	
B. Three-Phase Delta Connected Generator	
C. Single Phase Three Wire	
D. Single Phase Two Wire	
E. Generator Frame Ground	
F. Exciter Field Lead Wires	
G. Voltage Regulator	

## Table of Contents (Cont.)

- H. Voltage Regulator Fuse
- I. Voltage Regulator Systems Equipped with Paralleling Components
  - 1. Reactive Voltage Droop Compensation
  - 2. Reactive Different Compensation
- J. Voltage Shutdown Switch
- K. Field Circuit Breaker
- L. Automatic/Manual Voltage Control
- M. Space Heaters

### Section 5 Operation

PRE-START INSPECTION .....	5-1
IDLING .....	5-1
FIELD FLASHING .....	5-1
VOLTAGE ADJUSTMENTS .....	5-1
VOLTAGE RANGE ADJUST .....	5-2
STABILITY ADJUSTMENT .....	5-2
STARTING UP THE GENERATOR FOR SINGLE UNIT OPERATION .....	5-2
PARALLEL OPERATION .....	5-2
A. Prime Mover Governor	
B. Voltage Regulator Paralleling Provisions	
C. Synchroscope or Synchronizing Lights	
D. Metering	
Automatic/Manual Control During Parallel Operation .....	5-3
Phase Rotation .....	5-3
Pre-Paralleling Adjustments and Checks .....	5-3
Paralleling .....	5-3
Shuttling Down One or More Generators Operating Parallel .....	5-4

### Section 6 Preventive Maintenance

INSPECTION .....	6-1
CLEANING .....	6-1

### Section 7 Troubleshooting

GENERAL .....	7-1
TROUBLESHOOTING PROCEDURE .....	7-1
A. No Voltage	
B. Low Voltage	
C. High Voltage	
D. Voltage Fluctuating	

### Section 8 Generator Tests

MEASURING EXCITER FIELD EXCITATION .....	8-1
TESTING EXCITER ROTATING RECTIFIER DIODES .....	8-1
TESTING SURGE SUPPRESSOR .....	8-2

## Section 8 Generator Tests

MEASURING WINDING RESISTANCE .....	8-2
A. Measuring Exciter Field Winding Resistance	
B. Measuring Generator Field Winding Resistance	
C. Measuring Exciter Armature Winding Resistance	
D. Measuring Generator Stator Winding Resistance	
MEASURING WINDING INSULATION RESISTANCE .....	8-3
A. Measuring Generator Stator Winding Insulation Resistance	
B. Measuring Generator Field Winding Insulation Resistance	
C. Measuring Exciter Field Winding Insulation Resistance	
D. Measuring Exciter Armature Winding Insulation Resistance	

## Section 9 Drying Windings and Removing and Installing Parts

DRYING GENERATOR .....	9-1
A. Heated Enclosure	
B. Forced Air	
C. Oven	
REMOVING GENERATOR FROM ENGINE .....	9-1
REMOVING AND INSTALLING EXCITER ROTOR .....	9-2
A. Removing Exciter Rotor	
B. Installing Exciter Rotor	
REMOVING AND INSTALLING TERMINAL BOX AND ENDBELL .....	9-2
A. Removing Terminal Box and Endbell	
B. Installing Terminal Box and Endbell	
REMOVING AND INSTALLING BEARING .....	9-4
REMOVING AND INSTALLING GENERATOR ROTOR .....	9-5
A. Removing Rotor	
B. Installing Rotor	
INSTALLING REPLACEMENT SURGE SUPPRESSOR .....	9-5

## Section 10 Figures and Tables

GENERAL .....	10-1
Table 1 Generator Voltage Standard Kamag Generators .....	10-1
Table 2 Recommended Torque SAE 5 Steel and SAE 8 Steel Cap Screws .....	10-2
Table 3 Dimensions of Flywheels .....	10-3
Table 4 Minimum Air Gap for Kato Brushless Exciter .....	10-3
Figure 1 Single Bearing Kamag Generator with Outboard Exciter .....	10-3
Figure 2 Exciter Rotor Installation .....	10-4
Figure 3 Rotating Rectifier .....	10-4
Figure 4 Extension of Generator Rotor Shaft for Mounting of Exciter Rotor Assembly .....	10-5
Figure 5 SAE Flywheel .....	10-5
Figure 6 Single Bearing Generator Adaptor and Drive Plates .....	10-6
Figure 7 Recommended Torque Sequence for Circular Bolt Pattern .....	10-6
Figure 8 Checking Rotor Eccentricity .....	10-7
Figure 9 Checking Angular Alignment .....	10-7
Figure 10 Twelve Wire Generator Stator Lead Wire Connection Diagram .....	10-8
Figure 11 Exciter and Generator Field Interconnection .....	10-9
Figure 12 Field Excitation Measurement Meter Connection Diagram .....	10-9

# SECTION 1

## GENERAL INFORMATION, PRINCIPLES OF OPERATION AND MECHANICAL CONSTRUCTION

### GENERAL

KAMAG AC generators are brushless 4-pole machines producing 60 Hz power at 1800 rpm or 50 Hz power at 1500 rpm. The generators are of the revolving field type, having rotating field poles called the rotor and a stationary armature called the stator. All standard units are broad voltage range machines that have twelve lead wires brought out from the stator coil groups. This feature permits connection of the stator winding in either three-phase wye, three-phase delta, or single-phase configuration. Table 1 lists the voltages that can be obtained from the output of KAMAG generators.

Single bearing generators are supplied with an SAE adapter and flexible drive disks on the drive end of the unit. Alignment of the generator frame and engine is ensured by the concentricity of the flywheel housing and the generator adapter, while alignment of the generator rotor and engine crankshaft is ensured by the concentricity of the drive disks and engine flywheel.

Drawings and tables are contained in Section 10 in this manual.

The major parts comprising the KAMAG generator are shown on Figure 1. Figure 10 is an electrical schematic of the generator field and exciter. The twelve stator lead wires and respective stator coil groups are shown on Figure 11.

### PRINCIPLES OF OPERATION

Ac generators require direct current flowing through the field winding to set up the magnetic flux which generates ac power in the stator winding. An exciter, which is a small ac generator with rectified output, provides this direct current. While the generator armature is stationary and the field rotates, the exciter field is stationary and the armature and rectifier rotate.

The exciter itself requires direct current for excitation. This excitation may be provided by any dc power supply that provides the proper excitation. However, in order to keep the generator output voltage relatively constant, the dc excitation must be automatically regulated by means of a voltage regulator.

The voltage regulator provides regulated dc excitation. This device measures the generator voltage and compares the measured voltage with a pre-set voltage established by adjustment of a voltage adjust potentiometer or rheostat. It then uses the result of the comparative process to automatically control the excitation supplied to the exciter field winding. This action in turn regulates the excitation applied to the generator field winding, which controls the magnetic flux and thereby the ac power generated by the generator stator winding.

The voltage regulator requires electrical power for operation of its circuitry. Usually a portion of the power generated by the generator is used to power the voltage regulator.

### MECHANICAL CONSTRUCTION

The major parts comprising the KAMAG generator are shown in Figure 1 and described in the paragraphs that follow.

#### Generator Frame and Stator

Rectangular steel bars welded to endrings provide rigid support for the stator, the generator endbell, and the adapter. Weldments rigidly secure the stator to the frame bars.

The stator core is composed of a stack of thin, notched electrical steel laminations assembled under pressure and welded to the frame bars. The semi-closed notched slots are Class F insulated; random wound coils are firmly wedged in the insulated slots. The stator coils in KAMAG generators are connected in three-phase groups with twelve lead wires that terminate within the terminal box. Stator wire connections are insulated and the entire stator is then impregnated with thermo-setting 100 percent solid bonding epoxy and baked under a controlled cycle. This process minimizes voids and ensures high dielectric strength and excellent moisture resistance.

#### Generator Frame Cover

A removable sheet metal cover encloses the generator frame.

#### Generator Rotor Assembly

A precision machined steel shaft, the four-pole rotating field, the exciter armature and the rotating rectifier comprise the rotor assembly. Also mounted on the shaft and provided with a replacement rotor are the drive hub and the generator bearing. A two-section fan mounts on the rotor at the adapter end of the generator.

**A. Shaft**

The rotor shaft includes a keyway and key at the drive end for mounting the drive hub, a keyway and key for mounting the rotor field core, and a keyway and key for mounting the exciter armature and rotating rectifier.

**B. Generator Field Poles**

The four poles which carry the field windings are comprised of a stack of one-piece electrical steel laminations press-fitted together using a hydraulic press. Copper rods of the amortisseur winding are pressed into circular holes through the pole head portion of the core structure and welded to copper end plates that form the front and back section of the assembled field core structure. The field core structure is pressed on the shaft using a high pressure hydraulic press and keyed, forming a rigid rotating element. Round steel studs are pressed into each pole head for attachment of rotor balance rings at the front and back section of the field assembly.

Heavily insulated series-connected field coils are wound about the four poles. A support block made of insulating material provides coil support at the bottom and top of the field coil. Two lead wires are brought out to the rotating rectifier.

A thermo-setting epoxy is applied to the completed generator field assembly and the field assembly is baked under a controlled cycle to ensure high dielectric strength and mechanical strength.

**C. Driving Hub and Drive Disks**

The KAMAG single bearing generator is fitted with a precision machined interference fit drive hub that is keyed to the shaft. This hub carries a number of flexible steel drive disks which have holes for fastening to the flywheel. The outside and inside diameter are precision machined and bolt holes are precision located and drilled, ensuring concentric alignment with the drive hub and the engine flywheel. Ring shaped steel spacers used between the hub and disks provide a small amount of field adjustment to maintain proper alignment.

**D. Air Circulating Fan**

The fan consists of two half-sections that clamp together and are held securely in place on the shaft by two steel bolts. The fan mounts at the drive end of the generator between the drive hub and the generator field poles.

Ambient air is drawn into the outboard end of the generator, and passes over the exciter, across the outside of the generator stator windings and stator laminations, and through the air gap between the generator stator and field poles. This circulation of air removes heat from the windings and laminations. The cooling fan exhausts the heated air from the generator.

**E. Bearing**

Single bearing KAMAG generators have a duty-selected shielded ball bearing located at the outboard end of the generator. The bearing outer race is supported within a machined bearing housing located in the center of the endbell, while the inner race fits onto a machined section on the generator shaft. The bearing is factory packed with lubricating grease.

**Exciter Rotor**

The exciter rotor consists of the exciter armature wound with a three-phase winding and a full-wave rotating rectifier. Three-lead wires, one from each phase of the exciter armature winding, connect to the rectifier diodes as shown on Figure 11. The direct current from the rotating rectifier is conducted to the generator field through lead wires.

Two bolts mount the rectifier assembly to the exciter armature core structure. The entire exciter rotor unit slides over the generator shaft and is held in place by a rectangular key located in the shaft keyway and a retaining bolt and washer at the outboard end of the shaft as shown on Figure 2.

**A. Exciter Armature**

The exciter armature core structure is comprised of a stack of thin, notched, one-piece laminations held assembled under pressure and kept compressed and aligned by steel rivets through the stack of laminations. The semi-closed slots are insulated with Class F insulation, and the coils of the three-phase exciter armature

winding are then securely wedged in the slots. The entire exciter armature is completely impregnated with thermo-setting epoxy and baked under a controlled cycle. Three lead wires, one from each phase of the exciter armature winding, connect to the rotating rectifier as shown on Figure 11.

#### **B. Rectifier**

The exciter armature three-phase ac output is applied to a full-wave rectifier comprised of a positive heat sink, a negative heat sink, a molded insulating plate, a metal plate, three forward polarity diodes, three reverse polarity diodes, and a surge suppressor. The heat sinks are molded onto the insulating plate. The three forward polarity diodes mount on the positive heat sink, while the three reverse polarity diodes mount on the negative heat sink. A surge suppressor is mounted across the heat sinks. A generator field lead wire attaches to the positive heat sink while the second generator field lead attaches to the negative heat sink. This rectifier output circuit provides excitation to the series-connected generator field winding. Three wires, one from each phase of the exciter armature winding, attach to the diodes as shown in Figure 11. The complete rectifier assembly is held in place on the exciter armature by two bolts.

### **Exciter Field Assembly**

The exciter field core structure is comprised of a stack of thin, notched electrical steel laminations that are held axially and tangentially aligned by a weldment across the stack of laminations. The steel laminations are of the type that retain residual magnetism. This residual magnetism produces a magnetic field which, when the generator is started, induces current in the exciter armature, providing the generator field with sufficient dc excitation for generator voltage build-up.

The slots in the exciter field core structure are insulated with Class F insulation and the coils are then firmly wedged in the slots. The coils are series connected; lead wires are brought out for connection to the voltage regulator dc output. The entire exciter field assembly is completely impregnated with thermo-setting epoxy and baked under a controlled cycle. Bolts that pass through holes in the exciter field core structure and thread into tapped holes in the bosses located on the generator endbell provide rigid mounting and ensure concentric alignment.

#### **Endbell**

A cast iron endbell encloses the outboard end of the generator. Precision machined matching pilot and recess on the endbell and generator frame endring ensure concentric alignment with the generator frame. The endbell is rigidly secured to the frame by bolts that pass through holes in the terminal box and in the endbell and thread into tapped holes in the frame endring. A machined bearing housing at the center of the endbell supports the outer race of the generator bearing while raised bosses with tapped holes provide mounting for the exciter field assembly.

#### **Adapter**

A cast iron adapter at the drive end of the generator mounts to the engine flywheel housing while the inboard side of the adapter mounts to the generator frame endring. The face on both the inboard and outboard surfaces are precision machined with pilot or recess to ensure concentric alignment with the generator frame and the engine flywheel housing. Bolts that pass through the holes in the adapter and thread into tapped holes in the frame endring rigidly secure the adapter to the frame, while bolts that pass through the adapter and thread into tapped holes in the flywheel housing rigidly mount the generator frame and stator to the engine.

#### **Terminal Box**

KAMAG generators include a large terminal box with ample room inside for the voltage regulator, most circuit breakers, and other options. The twelve generator stator lead wires and the exciter field leads terminate within the terminal box. The terminal box mounts on the outboard end of the generator.

## SECTION 2 RECEIVING INSPECTION, HANDLING INSTRUCTIONS AND STORAGE

### RECEIVING YOUR KAMAG GENERATOR

Upon receipt of the generator it is recommended that it be carefully examined to determine if any shipping damage has occurred before accepting the shipment from the transportation company

Generators received during freezing weather should be slowly warmed to prevent condensation of moisture on the windings.

### WINDING INSPECTION

Winding inspection prior to operating the generator is recommended. If moisture is observed or condensation of moisture on the windings is suspected, a test of the stator winding insulation resistance should be made. If the result is less than the minimum value, the generator should be dried out.

Insulation resistance of the stator winding in the KAMAG generator should not be less than 1.48 megohms when calculated by the formula that follows.

$$\text{Minimum Winding Insulation Resistance in Megohms} = \frac{\text{Rated Voltage of Generator}}{1000} + 1$$

### UNPACKING

Unpack the generator carefully. Make certain that foreign material such as crating nails and packing material does not enter the generator. Read all instruction cards and keep all instructions, drawings, and test cards with the generator as this information will be required by personnel when installing, operating, and servicing the equipment.

### HANDLING INSTRUCTIONS

When installed, single bearing generator rotors are supported on the drive end by the drive disks bolted to the engine flywheel. While the engine is removed, the generator rotor must be supported by an appropriate fixture to prevent rotor, stator, or exciter damage.

KAMAG generators are shipped from the factory with rotor shipping support blocking bolted across the drive disks and adapter. Before transporting any generator, the main rotor must be supported by the adapter using an appropriate fixture.

After unpacking the generator, remove the exciter rotor. Leave the exciter rotor removed while transporting and coupling the generator to the engine.

### CAUTION

**Do not attempt to lift or transport any single bearing generator without proper rotor support. Failure to observe this precaution can result in extensive equipment damage. Make certain exciter rotor is removed while handling generator.**

When lifting your KAMAG generator, attach an overhead crane to the lifting eye(s) located on the generator frame. Apply lifting force in a vertical direction if possible. Make certain that crane, lifting cables, and other hardware used is of sufficient strength to safely lift the weight of the generator. Generator weight may be determined by referring to the weight given on the shipment bill of lading.

### WARNING

**Do not lift complete generator set by means of lifting eye(s) on generator. Disregarding these instructions may result in serious injury or equipment damage.**

**WARNING**

**Do not apply any lifting force to generator fan for lifting or turning generator rotor. Failure to observe this instruction may result in serious injury or equipment damage.**

**STORAGE**

When the generator will not be installed on the engine immediately it is recommended that it be stored in a clean, dry area which is not subject to rapid changes in temperature and humidity.

When storage will be for a period of six months or longer it is recommended the unit be wrapped with a thin water proof protective covering, and that a moisture absorbing agent such as bags of silica jel be placed within the covering.

## SECTION 3

### COUPLING AND ALIGNING GENERATOR AND PRIME MOVER

#### GENERAL

Flexible steel drive disks mount the generator to the engine flywheel while the face on the generator adapter mounts to the face on the flywheel housing.

Access to the interior of the generator is attained by removing the sheet metal cover that surrounds the stator. Access to the components mounted within the terminal box, such as the exciter and voltage regulator, is attained by removing the terminal box covers.

The generator rotor must be supported by appropriate blocking and the exciter rotor should be removed from the generator shaft while transporting the generator and coupling the generator to the prime mover. In case rotor support blocking has been placed in the generator air gap, be sure to remove support blocking after the bolts that mount the drive disks to the flywheel and the bolts that mount the adapter to the flywheel housing have been started. Install the exciter rotor after drive plate and adapter bolts have been tightened. Refer to the unpacking and handling instructions contained in Section 2 in this manual. Follow the procedure given in Section 9 when removing and installing the exciter rotor assembly.

The generator fan is made in two sections. Bolts hold the sections together and in place on the generator shaft. The fan can be taken apart in order to provide additional space while installing the bolts that mount the drive plates to the flywheel. Before removing or loosening the fan be sure to measure distance fan is located on the shaft from the generator field windings and the drive disks. Be sure to locate fan this distance on the shaft and be sure to tighten and torque fan bolts before operating the generator set. Do not pry on the fan blades. Refer to the handling instructions contained in Section 2 in this manual.

The top rib on the generator frame contains tapped holes for a lifting eye. The lifting eye provides a means for handling the generator. Do not lift complete generator set comprised of "coupled" engine and generator by the generator lifting eye(s). Refer to the handling instructions contained in Section 2.

#### PRE-COUPLING MEASUREMENTS

It is recommended the measurements that follow be made before coupling the generator to the prime mover.

##### A. Engine Crankshaft and Flywheel Deflection

Two methods often specified for measuring angular loading of coupled engine driven generator sets are a measurement of crankshaft deflection and flywheel deflection. Where specified by the engine manufacturer, deflection may be specified either as a maximum allowable deflection or as the difference between a measurement taken before the prime mover and generator are coupled and a measurement taken after the units are completely coupled. Where the latter is specified, be sure to make initial measurement before starting to couple the generator to the prime mover. Measure according to engine manufacturer's instructions.

##### B. Measuring Generator Drive Plate and Flywheel Driving Ring Pilot Bore

The generator drive plates fit into the flywheel driving ring pilot bore. To ensure correct fit, measure as follows.

1. Measure flywheel driving ring pilot bore diameter (dimension B, Figure 5). Compare measured diameter with dimension and tolerance given by flywheel manufacturer as shown in Table 3.
2. Measure generator drive plate diameter (dimension S, Figure 6). Drive plate diameter must not be greater than the flywheel driving ring pilot bore diameter.
3. Measure flywheel driving ring bore face runout. Compare measured runout with maximum tolerance specified by flywheel manufacturer.
4. Measure flywheel driving ring bore eccentricity. Compare measured eccentricity with maximum allowable eccentricity specified by flywheel manufacturer.
5. Measure eccentricity between the driving ring pilot bore B and pilot bearing bore L (see Figure 5). Compare eccentricity measured with maximum eccentricity specified by flywheel manufacturer.
6. Measure depth from flywheel housing face to the flywheel driving ring pilot bore face (dimension G, Figure 5). Compare measured depth G with dimension specified by flywheel manufacturer.

7. Compare measured depth from flywheel housing face to flywheel driving ring pilot bore face (dimension G, Figure 5) with the depth from the generator drive plates to the generator adapter (dimension Y, Figure 6).

**NOTE: Where dimensions G and Y are not identical, the circular spacer located between the generator drive hub and the drive plate may be removed or another spacer may be added. Before making any change be sure exciter is axially aligned and bearing has at least 1/8 inch endclearance. Excessive bearing endclearance may prevent bearing outer race from being fully seated in the bearing housing portion of the endbell.**

### C. Checking Exciter Alignment

Excessive axial misalignment of the exciter armature core and the exciter field can result in low generator excitation and excessive exciter field current. Alignment can be visually checked as given in the procedure that follows.

### CAUTION

**Do not pull or push on rotating rectifier or winding. Failure to observe this precaution can result in equipment damage.**

1. Temporarily slide the exciter rotor (comprised of the exciter armature and rotating rectifier) onto the generator shaft. Make certain inside edge of the exciter armature core is against the raised step on the shaft.
2. Visually check axial alignment.
3. Remove exciter rotor. Install after generator has been coupled to the engine.

### D. Checking Bearing Endclearance

Insufficient bearing endclearance can result in thrust load on bearing which will shorten bearing life. Before coupling generator to the engine check bearing endclearance. Refer to the procedure that follows.

1. Make certain generator rotor is axially aligned. Refer to preceding directions.
2. Wrap sling around generator drive hub and attach sling to hoist or place portable jack under drive hub. Take up slack but do not lift. Watch to make certain generator air gap is maintained.
3. Temporarily remove support block from drive end of the generator.
4. With exciter rotor removed, measure from end of the shaft to the bearing housing surface on endbell (dimension A, Figure 4).
5. Push on drive end of the generator rotor until rotor stops moving. This is zero bearing endclearance.
6. Again measure from end of the shaft to the bearing housing and compare this measurement with dimension A measured during step 4. The difference should not be less than 1/8 inch.
7. Remove cover from around generator and visually check to make certain bearing outer race is completely into the bearing housing section in the endbell.
8. Where measurement and checks made in preceding steps 6 and 7 are satisfactory, pull rotor back to the original position measured during preceding step 4.

**NOTE: In case bearing endclearance is less than 1/8 inch or bearing outer race is not into the bearing housing, set for 1/8 inch bearing end-clearance, recheck exciter alignment, and then add or remove spacer as necessary from drive end of the generator to attain the correct Y dimension.**

## COUPLING AND MOUNTING GENERATOR ONTO ENGINE AND BASE

Couple the generator to the prime mover and mount the generator in accordance with the instructions provided by the engine generator set assembler.

The instructions that follow and those contained in preceding sections in this manual are included to facilitate correct coupling of the generator set and to help prevent equipment damage. Review preceding instructions before beginning the following procedure. It is recommended the "Pre-Coupling Measurements" be made before lifting the generator onto the generator set base (see page 3-1).

**CAUTION**

**The exciter air gap is small compared to the air gap within the main generator. Remove exciter rotor before transporting and coupling the generator to the prime mover. Failure to observe this precaution can result in equipment failure.**

1. Lift generator onto base with overhead crane. Leave rotor support in place while lifting the generator.
2. Support drive end of generator shaft by wrapping a cable around the drive hub and attaching the cable ends to an overhead hoist or use jack under drive hub. Position jack base on either the generator adapter or the cross member on generator set base.

**NOTE: Where generator has removable screen and cover around the adapter, those items may be removed to attain access for cable.**

3. Remove wooden support block from face of drive plates and adapter and, where provided, remove support blocking from generator air gap. Be sure to maintain exciter and generator air gap.

**NOTE: Step 4 that follows is necessary only where sufficient room does not exist for installing bolts that mount the drive plates to the flywheel.**

4. Measure and record axial distance from fan to drive plates. Then loosen or remove fan. When installing fan be sure to position the fan according to this dimension.

**WARNING**

**Do not lift or pry on generator fan. Failure to observe this precaution can result in serious injury and equipment damage.**

Be sure to maintain air gap while following steps 5 through 9 that follow.

5. Attach drive plates to the flywheel. SAE Grade 8 bolts are recommended. Make certain plates fit completely into the driving disk recess bore in the flywheel. Move generator stator as necessary to maintain axial alignment of the generator rotor within the stator.
6. Remove sling and hoist from drive hub. Then torque coupling bolts (see Table 2 and Figure 7).
7. Use overhead hoist or jack to align adapter face with the flywheel housing. Check to make certain that faces are parallel using feeler gauge. Install and torque bolts (see Table 2 and Figure 7).
8. Level generator base with the generator set base. Use shims, when necessary.
9. Remove hoist from generator lifting eye(s).
10. Install and torque bolts that mount the generator to the base (see Table 2).

**WARNING**

**Make certain that sufficient clearance exists between fan and stationary parts and make certain fan and fan hub bolts are torqued. Failure to observe this precaution can result in serious injury and equipment damage.**

11. Install generator fan and torque fan bolts. See preceding step 4. Torque SAE 5 bolts according to torque listed in Table 2.
12. Check to make certain support blocking and other loose material is removed from air gap.
13. Measure distance from end of generator shaft to the bearing housing portion on endbell (dimension A, Figure 4). Compare measurement with that taken in steps 4 and 6 of preceding procedure titled "Checking Bearing Clearance."

**CAUTION**

**Do not push on rotating rectifier or exciter winding. Failure to observe this precaution can result in equipment damage.**

Install exciter rotor as described in steps 14 through 16 that follow.

14. Install key in keyway located in generator shaft. Align exciter rotor with key and push exciter rotor onto generator shaft. Make certain inside edge of exciter armature core is against raised step on shaft.
15. Connect generator field leads onto the (+) and (-) terminals located on the rotating rectifier heat sinks.
16. Install exciter rotor retaining bolt and washer. Torque 1/2 inch bolt to 60 foot-pounds.
17. Check exciter axial alignment.
18. Measure exciter air gap with feeler gauge as described in step 19 that follows. Air gap at tightest point should not be less than that listed in Table 4.
19. Measure completely around exciter air gap to determine tightest point. Then, keeping gauge at this point, bar engine or flywheel through one revolution, measuring air gap as rotor turns. **DO NOT PRY ON GENERATOR FAN.**
20. When specified by the engine manufacturer, test flywheel deflection or crankshaft deflection.
21. Measure generator rotor eccentricity as described in the procedure that follows.
22. Measure generator rotor angular alignment as described in the procedure that follows.
23. After coupling and mounting is complete and measurements are satisfactory, inspect to make certain all bolts are tight and torqued (see Table 2).

### **WARNING**

**When circuit breakers are not included with the generator, the terminals on the ends of the stator lead wires are not insulated. These terminals must be insulated before generator set is operated. Failure to observe this precaution can result in serious injury and equipment damage.**

24. Bar engine or flywheel through at least one revolution, checking to make certain that clearance exists between stationary and rotating parts. **DO NOT PRY ON GENERATOR FAN.**
25. Check to make certain that tools and shop cloths are removed from in and around generator set. Make certain that wiring is connected and lugged ends are insulated. Then install generator covers.
26. Disconnect engine starting circuit; then operate engine through cranking cycle. Listen for any abnormal rubbing or scraping noises.

### **MEASURING GENERATOR ROTOR ECCENTRICITY**

After the generator has been coupled to the prime mover, a measurement of generator rotor eccentricity should be made to ensure generator rotor shaft has been aligned with the engine. Do not pry on generator fan. Measure eccentricity and, where necessary, correct alignment as follows.

1. Mount dial indicator base on the generator adapter and position the dial indicator finger on the generator drive hub or generator shaft as shown on Figure 8.
2. Set dial indicator needle to zero.
3. Bar engine or flywheel one revolution. Do not pry on generator fan.
4. Eccentricity should not exceed .003 inch total indicator reading on 1500 rpm to 1800 rpm generator sets.
5. In the event eccentricity exceeds the maximum tolerance given above, align coupling as given in procedure 6 or 7 that follows.
6. Attach hoist and cable about drive coupling to support drive end of generator rotor or use jack under drive hub with jack base on adapter rib or base cross member. Loosen bolts that mount the drive plates to the flywheel. Then move drive plates in the direction within the flywheel driving ring recess bore that will decrease eccentricity. Remove cable hoist, torque bolts, and again measure eccentricity.
7. To decrease eccentricity it may be necessary to rotate the drive plates with respect to the flywheel driving ring pilot bore. Support the drive end on the generator rotor with a cable and hoist or jack. Remove coupling bolts and turn the flywheel. Be sure to keep the generator drive plates stationary. Rotate the flywheel to position where eccentricity will be minimum and bolt holes are aligned. The install and torque bolts, remove cable and hoist, and again measure eccentricity.

## MEASURING ROTOR ANGULAR ALIGNMENT

After the generator has been coupled to the prime mover, a measurement of angular alignment of the generator rotor with the engine flywheel should be made. Measure angular alignment and, where necessary, correct as follows.

1. Measure approximate distance between shaft center and any convenient point on the flywheel slightly larger than the driving ring pilot bore. This dimension is used in the procedure described in steps 2 and 6 that follow.
2. Mount dial indicator base on the generator fan and position the dial indicator finger on the flywheel according to dimension measured in step 1 and as shown on Figure 9.
3. Set dial indicator to zero.
4. Do not pry on generator fan.
5. Bar engine or flywheel through one revolution while measuring angular runout.
6. Angular runout must not exceed  $\pm .010$  inch per foot of radius measured from shaft center to indicator finger. Where radius used during measurement is other than one foot, calculate according to dimension from preceding step 1.
7. In the event excessive angular runout occurs, inspect and measure or verify the previous measurements as necessary to ensure the items that follow were installed correctly and tolerances are within the specified limits.
  - a. Make certain that drive plates are seated in the flywheel driving ring pilot bore and coupling bolts are torqued (see Table 2 and Figure 7).
  - b. Verify that adapter face and flywheel housing face are aligned and bolts are torqued (see Table 2 and Figure 7).
  - c. Verify that while mounting the generator to the base an angular load was not applied causing flywheel housing deflection. Check may be made by loosening mounting bolts and moving generator stator slightly with hoist or jack screws while measuring angular alignment.

**NOTE:** For some engine generator combinations, the flywheel housing may have to be supported by feet to attain angular alignment.

- d. Verify that flywheel deflection and crankshaft deflection are not excessive.
- e. Verify that the generator driving plate bore is concentric with the driving plate pilot on the generator drive hub.
- f. Verify that the flywheel housing face runout does not exceed specified tolerance.
- g. Verify that flywheel driving ring pilot bore face runout does not exceed specified tolerance
- h. Verify that the eccentricity between the flywheel pilot bore (L) and the driving ring pilot bore (B) does not exceed specified tolerance

## SECTION 4

# ELECTRICAL CONNECTIONS

### GENERAL

KAMAG generators have twelve stator lead wires that terminate within the terminal box. The two lead wires from the exciter field winding also terminate within the terminal box.

The generator may be connected three-phase series wye, three-phase parallel wye, three-phase series delta, three-phase parallel delta or single phase. The units may be operated 60 Hertz, 1800 rpm or 50 Hertz, 1500 rpm. The voltage regulating system voltage control rheostat permits adjustment of generator output voltage.

Voltage generated when stator lead wires are connected in one of the configurations described above is listed in Table 1. Select the hookup that will provide the appropriate voltage. Be sure to connect the generator stator, load lines and voltage regulator as shown in the wiring diagram provided with the generator. Observe the general precautions that follow.

#### A. Three-Phase Wye Connected Generator

For a 4-wire system the neutral line may be brought out to the load distribution system. Where electrical code requires system ground, be sure the neutral leg is electrically connected to ground stud or ground wire.

#### B. Three-Phase Delta Connected Generator

Where generator is connected 3-wire delta, the stator connection neutral should not be connected to the ground stud and load lines do not contain a neutral line. The load conductors (phase A, B, and C) should not be grounded.

#### C. Single Phase Three Wire

Neutral (N) and two load conductors (L1 and L2) are contained in the load distribution system. Where electrical code requires system ground, neutral leg may be grounded.

#### D. Single Phase Two Wire

Two load conductors connect to the load distribution system. In single phase two wire 200-240 VAC applications where generator neutral is grounded, the two load conductors must not be grounded.

#### E. Generator Frame Ground

Generator frame should be connected to an earth ground in accordance with electrical code. Ground wire must be connected to the generator ground stud located above the left mounting foot.

#### F. Exciter Field Lead Wires

Exciter field lead wires F+ and F- connect to the voltage regulator output terminals F+ and F-. Be sure to maintain polarity. THIS CIRCUIT MUST NOT BE EITHER GROUNDED OR OPENED WHILE GENERATOR IS RUNNING.

#### G. Voltage Regulator

Refer to the voltage regulator instruction manual and the wiring diagram provided with the generator set. Make certain all internal and external connections are correct before operating the generator set.

### **CAUTION**

**Incorrect electrical connection of the voltage regulator can result in immediate equipment damage.**

#### H. Voltage Regulator Fuse

This fuse protects the voltage regulator circuitry.

In applications where the generator set does not include a field circuit breaker it is recommended that a 1 1/2 ampere normal blow fuse be used in the voltage regulator. This would protect the Kamag generator against excessive voltage due to loss of sensing and excessive field forcing.

#### I. Voltage Regulator System Equipped with Paralleling Components

Refer to the voltage regulator instruction manual, the wiring diagram provided with the generator set, and the parallel operation instructions contained in Section 5 in this manual.

Where generators will be operated parallel, the voltage regulating system must include additional paralleling provisions either internally or external to the regulator and each regulating system must include a parallel operation current transformer.

The parallel operation components may be connected by either of the two methods that follow.

**1. Reactive Voltage Droop Compensation (Formerly known as parallel droop compensation)**

To attain reactive voltage droop compensation in parallel equipped voltage regulators, the generator set parallel operation current transformer connects to its respective voltage regulator. When connected in this manner the bus voltage droops, or decreases, as the reactive lagging power factor load is applied. Where this method is required, connect the current transformers as described in the voltage regulator instruction manual and generator set wiring diagram.

**2. Reactive Differential Compensation (Formerly known as cross-current compensation)**

To attain cross current compensation in parallel equipped voltage regulators, the parallel current transformers are interconnected and also connect to their respective voltage regulators. Reactive differential compensation permits reactive load sharing without a droop, or decrease, in generator voltage. Where this method is required, connect the current transformers as described in the voltage regulator instruction manual and generator set wiring diagram.

**J. Voltage Shutdown Switch (Engine Idle Switch)**

Where this accessory is provided, connect as described in the voltage regulator instruction manual and generator set wiring diagram.

**K. Field Circuit Breaker**

Where this accessory is provided, connect as described in the voltage regulator instruction manual and the generator set wiring diagram.

**L. Automatic/Manual Voltage Control**

Where this accessory is provided, connect as described in the voltage regulator instruction manual and the generator set wiring diagram.

**M. Space Heaters**

Where this accessory is provided, connect as described on the generator set wiring diagram.

## SECTION 5 OPERATION

### PRE-START INSPECTION

Before operating the generator for the first time, the following checks are recommended.

#### **WARNING**

**When circuit breakers are not included with the generator, the terminals on the ends of the stator lead wires are not insulated. These terminals must be insulated before generator set is operated. Failure to observe this precaution can result in serious injury and equipment damage.**

- A. Check to make sure bolts that mount and couple the generator onto the engine and engine base are tight.
- B. Check to make sure fan bolts are tight and space exists between the fan and stator windings. Check to make sure exciter retaining bolt is tight.
- C. Check all wiring against the proper connection diagrams and make sure all connections are properly insulated.
- D. Inspect to make sure all packing materials and shipping support blocking has been removed. Remove loose cloths and tools.
- E. Install covers and guards.

### IDLING

Permanent equipment damage can be caused by having the generator set in operating mode while idling the engine. If engine adjustments require that the engine be run at idle speed, the generator set regulating system should be made inoperative by one of the methods that follow.

- A. Where generator set is provided with voltage shutdown switch, be sure switch is set to IDLE position while engine is running at idle speed.
- B. Where generator set is equipped with field circuit breakers, be sure the circuit breaker is set to OFF while engine is running at idle speed.
- C. Where generator set includes an automatic/manual control with switch that has OFF position, be sure switch is set to OFF while engine is running at idle speed.
- D. Where generator set does not include switches described above, be sure voltage regulator fuse is removed while engine is running at idle speed or remove wires from the voltage regulator input power terminals during underspeed operation of the generator set.

### FIELD FLASHING

The generator relies on residual voltage to start the generator action which in turn generates the rated voltage. If the generator fails to generate voltage after it has come up to rated speed, it may be necessary to flash the exciter field. Field flashing must be done while the generator is at a standstill as described in the procedure that follows.

1. Stop the engine and open the output circuit breaker.

#### **CAUTION**

**Be sure to maintain polarity (+) to (F+) and (-) to (F-).**

2. Connect the negative lead (-) from a common 12 volt storage battery onto exciter field lead F-.
3. Connect the positive lead (+) from the battery onto exciter field lead F+. Only a few seconds flashing should be necessary.
4. Remove battery and connect exciter field leads onto voltage regulator terminals F+ and F-. Be sure to maintain correct polarity.
5. Start generator and check for satisfactory voltage build up.

### VOLTAGE ADJUSTMENTS

A means for adjusting the voltage is incorporated in the regulator. For details refer to the voltage regulator instruction manual applicable for this unit.

## **VOLTAGE RANGE ADJUST**

This control is incorporated in most voltage regulators. For details refer to the voltage regulator instruction manual applicable for this unit.

## **STABILITY ADJUSTMENT**

This control is incorporated in most voltage regulators. It provides a means of adjusting a stabilizing signal which prevents generator voltage oscillation. For details refer to the voltage regulator instruction manual applicable for this unit.

## **STARTING UP THE GENERATOR FOR SINGLE UNIT OPERATION**

The following procedures should be followed for starting up the generator set.

1. The generator output must be disconnected from the load. Be sure the main circuit breaker is open.
2. If fuses have been removed, install the fuses.
3. Where generator set is equipped with field circuit breaker, set breaker to ON.
4. Where generator set is equipped with voltage shutdown switch, set switch to RUN position.
5. Where generator set is equipped with Automatic/Manual control, set switch to AUTO position.
6. Where space heaters have been supplied with the generator set, turn off the heater before operating the generator.
7. Where generator sets are equipped for parallel operation and include UNIT/PARALLEL switches, set switch to UNIT position whenever generator is operated singly.
8. Start generator set and bring to rated speed. Adjust voltage to required value by means of the voltage adjust rheostat.
9. Close the main circuit breaker and apply load.
10. Adjust engine speed to 1800 rpm for 60 Hertz, 1500 rpm for 50 Hertz.
11. Before stopping the engine, remove the load by tripping the main circuit breaker.

## **PARALLEL OPERATION**

KAMAG generators come standard with amortisseur windings. This feature makes all KAMAG generators suitable for parallel operation when the proper control equipment is added.

Generators operating parallel must deliver power to the load without delivering power to each other or accepting power from the load bus or power grid.

Additional equipment is necessary to ensure safe and successful parallel operation. The amount of control gear will be determined by the needs and requirements for the particular application. A description of the minimum control equipment necessary for parallel operation follows.

### **A. Prime Mover Governor**

The prime mover speed will directly control the kilowatt load and frequency of the unit. The governor must have special paralleling and droop provisions to permit parallel operation with other units.

### **B. Voltage Regulator Paralleling Provisions**

The voltage regulator controls the generator output voltage and the reactive power supplied by the generator.

Where two or more generators operate parallel, the voltage regulators must have a similar characteristic, and each regulator must include paralleling provisions either internally or external to the regulator. These include an external current transformer for each regulating system, a voltage droop adjustment for each regulating system, and paralleling transformer or equivalent circuitry internally or external to the regulator. Where parallel systems are interconnected for reactive differential compensation, each regulating system should include either a UNIT/PARALLEL switch or auxiliary contact on the generator circuit breaker.

### **C. Synchroscope or Synchronizing Lights**

Where generator is being paralleled with another generator supplying power to the system bus, the voltage of the incoming unit must be in phase with that of the load bus at the instant its circuit breaker closes.

Attempting to parallel units while out-of-phase voltage condition exists will result in very high transient voltage and mechanical strain which can result in extensive equipment damage.

A synchroscope or synchronizing lights provide means of determining when generator is inphase with the bus voltage.

**D. Metering**

In order to check for proper parallel operation, all generators should be equipped with the following monitoring equipment.

- Synchroscope or Synchronizing Lights
- AC Voltmeter
- AC Ammeter
- Frequency Meter
- kW Meter
- kVAR or Power Factor Meter

**Automatic/Manual Control During Parallel Operation**

Where one or more of parallel operation generator sets are equipped with automatic/manual control circuitry, all generators must be operated in the automatic voltage control mode during parallel operation. This is accomplished by setting the automatic/manual control selector switch to AUTO position.

**Phase Rotation**

For parallel operation each generator must have the same phase rotation with respect to the load bus. Each generator should be checked to ensure correct phase rotation before parallel operation is attempted.

**Pre-paralleling Adjustments and Checks**

Before operating generator sets parallel, each set should be checked by starting, operating, and adjusting the sets as individual units before paralleling.

The following points are basic criteria which must be met before two units can be paralleled.

- A. The generators must have the same phase rotation. Test by using phase rotation meter or checking rotation of induction motor connected to load bus.
- B. The voltage regulator characteristics of the individual generators should be similar and must include parallel operation circuitry.
- C. Paralleling current transformers must give the same secondary current.
- D. Current transformer secondary winding provides reactive kVA droop signal to the voltage regulator. Accidental reversal of this electrical wiring will cause voltage to rise rather than droop. If this occurs, stop unit and reverse wires at voltage regulator terminals CT1 and CT2.
- E. Each set must be individually adjusted for identical voltage droop. Individually test and adjust with an inductive load applied that is proportional to full load rating of unit.
- F. Where generator sets include UNIT/PARALLEL switch, set switch to PARALLEL position on units being brought on the load bus.
- G. The engines must have the same speed regulating characteristics, and the governors must be adjusted to give the same speed regulation. Individually test and adjust with load applied that is proportional to full load rating of generator.
- H. Each engine governor must be adjusted for identical speed droop. Individually test and adjust by applying load that is proportional to full load rating of the generator.

**Paralleling**

Verify that units are properly equipped for parallel operation and adjustments have been made as described in preceding instructions. General procedure follows.

1. Where generator set includes automatic/manual voltage control, set AUTO/OFF/MANUAL switch on all units to AUTO position.
2. On generating systems equipped with UNIT/PARALLEL switches, set switch on unit being started (generator set No.1) to PARALLEL position (open). Set switch on remaining generator sets to UNIT position (closed).
3. Start generator set No. 1.
4. Adjust generator voltage and engine speed.
5. Apply the load.
6. Verify satisfactory voltage regulation and make certain frequency is not fluctuating.
7. Repeat procedures 1 and 2 on generator set No. 2.
8. Start generator set No. 2.

9. Adjust generator set No. 2 speed and voltage.
10. Adjust speed of generator set No. 2 slightly higher than that of generator No. 1.
11. Observe the synchroscope (or lights). When generator No. 2 is inphase with generator No. 1, close the circuit breaker for generator No. 2.
12. Immediately after closing the circuit breaker, measure line current of generator No. 2. It should be well within the rating of the generator. Also, immediately after closing the circuit breaker, observe the kW or power factor meters. The following conditions could occur.
  - a. **A high ammeter reading accompanied by a large kW unbalance.** When this condition exists, the speed governor is either not adjusted correctly or is faulty.
  - b. **A high ammeter reading accompanied by a large kVAR unbalance.** When this condition exists, the voltage regulating system is either not adjusted correctly or is faulty.
13. Adjust the speed of generator set No. 2 to the rpm where each generator is carrying the desired share of kW load. (See Note following procedure 14).
14. Adjust the voltage of generator No. 2 until the ammeter readings of both generators are near minimum. (See following Note).

**NOTE: If kVAR or power factor meters are available, adjust voltage adjust rheostats for equal or proportional kVAR or power factor readings.**

**If the generators are equipped with power factor meters, alternately adjust the speed and voltage on No. 2 until the ammeter readings are proportional and the power factor readings are equal.**

**NOTE: To obtain best results, final adjustments should be made with full load on the bus.**

15. With full load applied, readjust the speed and voltage of generator No. 2 until the desired load division is obtained.

**NOTE: The best adjustment is obtained when each generator supplies the same percent of its rated current, the power factor readings are equal, or the sum of the ammeter currents is minimum.**

16. In applications where three or more generators are to be operated parallel, repeat procedures 7 through 15 for generator set No. 3, then No. 4, etc.

### **Shutting Down One or More Generators Operating Parallel**

Before dropping one or more generators operating parallel from the line bus it is essential that the total load on the bus is reduced to equal to or less than the combined capacity of the generators remaining on the bus. Shut down one or more of generator sets operating parallel as follows.

1. Reduce load to combined capacity of generators remaining on the bus.
2. On systems where the prime mover governor is equipped with a manual speed adjust, the load can be shifted to generators remaining on the bus by reducing the speed of the generator set being dropped from the bus.
3. Open the circuit breaker on the generator set being taken off the bus.
4. Close its UNIT/PARALLEL switch (on generator sets equipped with a UNIT/PARALLEL switch).
5. Shut down the prime mover.
6. In applications where three or more generators are operated parallel, repeat preceding procedures 1 through 5 for each generator set being taken off the bus.

## **SECTION 6 PREVENTIVE MAINTENANCE**

### **INSPECTION**

To ensure peak performance and maximum service life, the generator must be kept in good condition. This can best be ensured by periodic inspection of the unit and immediate repair of minor problems. The preventive maintenance inspection schedule that follows is enclosed as a guide for establishing a preventive maintenance program.

#### **A. Daily or Whenever Generator Is Operated**

Before starting generator be sure air inlet and air exhaust screens are not clogged.

While generator is running be sure voltage is correct and not oscillating.

While generator is running observe any unusual noise or vibration.

#### **B. Once Every Six Months**

Remove terminal box cover and inspect wiring for signs of damaged insulation and loose or corroded connections. Repair damaged wiring; clean and tighten connections.

Inspect control devices for accumulation of dust, moisture or other foreign material. Clean using nylon bristle brush or compressed air at pressure between 25 PSI and 50 PSI.

Inspect to make certain that bolts which mount the voltage regulator, circuit breakers, meters, etc. have not loosened. Tighten as necessary.

Remove or loosen cover that surrounds generator frame. Inspect inside of generator frame. Inspect inside of generator for signs of damaged winding insulation and excessive dirt or moisture. Inspect to make certain bolts are tight.

### **CLEANING**

#### **A. Controls**

Clean using nylon bristle brush or compressed air at pressure between 25 PSI and 50 PSI.

#### **B. Generator**

Wipe exterior of generator and air intake and exhaust with cloth or nylon bristle brush. Clean loose dust or other abrasive material from generator interior using compressed air at pressure between 25 PSI and 50 PSI.

## SECTION 7 TROUBLESHOOTING

### GENERAL

Loose, corroded, or broken connections and wiring errors are often the cause of generator malfunction. Before assuming problem is within the generator or voltage regulator, check condition of wiring and terminal connections and verify wiring according to wiring diagrams provided with the generator set.

### TROUBLESHOOTING PROCEDURE

The troubleshooting information that follows is divided by symptoms. They are: no voltage, low voltage, high voltage, and voltage fluctuating.

Observe the safety precautions in the Safety Summary at the front of this manual before operating, testing or making repairs to this equipment.

#### A. No Voltage

1. Shut down the generator set.
2. Remove terminal box cover and check generator leads and interwiring to the voltage regulator for loose or broken connections.
3. Check regulator fuses with ohmmeter. If defective, replace.
4. Start up generator. Measure ac voltage at input power terminals on the voltage regulator. The voltmeter reading should exceed 7 vac. If it does not, field flashing is required. Refer to field flashing procedure in Section 5 of this manual.
5. Where voltage reading before or after field flashing exceeds 7 vac but output voltage fails to build-up, shut down the generator set. Then proceed as described to either step 6 or steps 7 and 8 that follow.
6. Connect meters as shown in Figure 12. Then start generator set and measure exciter field excitation as described in Section 8.
7. Shut down the generator set. Disconnect voltage regulator by removing the voltage regulator fuse. Where regulator does not include fuse, disconnect voltage regulator by removing the connections to the regulator input power terminals. Insulate terminal lugs on wires to prevent grounding during test described in step 8 that follows.
8. Disconnect wires F+ and F- from regulator output terminals F+ and F-. Connect a common 12 volt storage battery to wires F+ and F-, keeping the polarity the same. Start up the generator set. While the generator is operating at a rated speed, read the voltage output of the generator measured by a voltmeter. If the reading is one-half or greater of the rated output when there is no load on the generator, the problem is in the voltage regulator. If the voltage remains near zero, the voltage regulator is good, and the problem is most likely within the exciter or generator. Shut down the generator. Reconnect the voltage regulator and proceed to step 9.
9. Remove cover located on end of terminal box. Examine the rectifier diodes for loose or broken connections. Proceed to step 10.
10. Test the generator exciter rotating rectifier diodes as described in the procedure contained in Section 8. Refer to Figures 3 and 11. Install diodes and reconnect generator field leads.
11. Test surge suppressor as described in Section 8. Surge suppressor is mounted across the positive and negative heat sinks on the exciter rectifier. If test shows replacement is necessary, see installation instructions in Section 9. Part location and electrical connections are shown on Figures 3 and 11. Reconnect generator field leads. If test indicates surge suppressor is good, proceed to step 12.
12. Check windings for continuity as described in the winding resistance test procedure contained in Section 8. If opens or shorts are found in the exciter stator or exciter armature, replace the necessary component. If the condition is found in the generator stator or the generator rotor field winding, major repair or generator replacement is probably required.
13. Connect wiring in accordance with wiring diagram(s) provided with the generator set.

**B. Low Voltage**

1. Test using auxiliary voltmeter connected at generator load leads.
2. Shut down the generator set.
3. Remove cover located at end of terminal box. Check main generator leads and wiring to the voltage regulator for correct connection. Make certain that connections are tight and not corroded.
4. Start up the generator set. Verify correct speed (1800 rpm for 60 hertz and 1500 rpm for 50 hertz).
5. Be sure the voltage adjust rheostat is adjusted as necessary to increase generator voltage.
6. Adjust the voltage range potentiometer clockwise to increase generator voltage.
7. Where voltage is normal with no-load applied but drops with load applied, make certain load does not exceed nameplate capacity. Verify using clamp-on ammeter on the generator load lines. Current in any line must not exceed nameplate amps.
8. Shut down the generator set and open the output circuit breaker.
9. Check wiring to the voltage regulator sensing and input power terminals. Where voltage regulator has multi-tap sensing transformer, make certain connections to the transformer are correct. Where voltage regulator has different internal connections for 60 Hertz and 50 Hertz operation, verify connections are correct. Where voltage regulator is of the series boost saturable transformer type, verify that boost winding is connected correctly. Refer to the voltage regulator instructions and the wiring diagrams provided with the generator set. Where connections are found to be correct, proceed as follows.
10. Continue by testing either field excitation as described in step 11 or test using battery as described in steps 12 through 14.
11. Connect meters as shown in Figure 12. Then start generator set and measure exciter field excitation as described in Section 8.
12. Disconnect the voltage regulator by removing wires at the regulator input power terminals and the regulator output terminals F+ and F-. Tape ends of input power wires to prevent accidental ground or short during the test described in step 11.
13. Connect a common 12 volt storage battery to exciter field lead wires F+ and F-, keeping the polarity the same. Start up the generator set. While the generator is running at rated speed, read the voltage output. If the reading is one-half or greater when there is no-load on the generator, the problem is in the voltage regulator. If the reading remains near zero, the problem is most likely within the exciter or generator.
14. Shut down the generator set. Remove battery and reconnect voltage regulator determined to be in good condition. If preceding test indicated that the problem was within the exciter or generator, test as described in the steps that follow.
15. Remove the cover located on end of terminal box. Examine the rotating rectifier diodes for loose or broken connections. If connections are good, proceed to step 16.
16. Test rotating rectifier diodes using an ohmmeter as described in Section 8. If one reading is high and the other is low, the diode is good. A shorted diode will have very low resistance in both forward and reverse polarity while an open circuited diode will exhibit high resistance in both forward and reverse polarity. Install good or replacement diodes. Connect generator field leads.
17. Test surge suppressor as described in Section 8. Install replacement surge suppressor as described in Section 9. Re-connect generator field leads. If test indicates that surge suppressor is good, proceed to step 18.
18. Check windings for continuity as described in the winding resistance test procedures contained in this manual. If opens or shorts are found in the exciter stator or exciter armature, replace the necessary component. If the condition is found in the generator stator or rotor, major repair or generator replacement is probably required.

**C. High Voltage**

1. Verify by testing with an auxiliary voltmeter at the generator load lines.
2. Be sure the voltage adjust rheostat is adjusted as necessary to reduce voltage.
3. Adjust the voltage range potentiometer in the voltage regulator counter-clockwise to reduce voltage.
4. Shut down the generator set and open the generator output circuit breaker.
5. Remove terminal box cover and check generator set wiring for correct connection.

6. Check wiring to the voltage regulator sensing and input power terminals for correct connection. Check voltage regulator sensing transformer for correct connection. Where voltage regulator includes different internal connections for 50 Hertz or 60 Hertz, verify that connections are correct. Where voltage regulator is of the type that has boost transformer or winding, verify that connections are correct. Refer to the wiring diagrams provided with the generator set and the voltage regulator instructions.

#### **D. Voltage Fluctuating**

1. Verify generator voltmeter performance using auxiliary voltmeter at generator lines.
2. Verify engine governor performance with a tachometer to ensure stable engine speed.
3. Where generator is providing power to SCR type load, transient voltage spikes during SCR switching can cause voltage to fluctuate. If this is the case, set stability adjust for slower regulator response.
4. Adjust voltage regulator stability control potentiometer as described in the voltage regulator instruction manual. Test with no load applied and again with load applied.
5. Shut down generator set and open generator output circuit breaker. Remove the terminal box cover and check all wiring for loose connections.
6. Where wiring is found to be correct and in good condition, proceed to either step 7 or steps 8 and 9.
7. Connect meters as shown on Figure 12 and measure exciter field excitation as described in Section 8.
8. Shut down generator set and remove cover located on end of terminal box. Proceed to step 9.
9. Disconnect the voltage regulator by removing the connections to the regulator input power terminals. Tape lugged ends on wires to prevent ground or short during test. Remove F+ and F- exciter field lead wires from the F+ and F- terminals on the voltage regulators. Connect a common 12 volt storage battery onto exciter field leads F+ and F- keeping the polarity the same. Start up the generator set. While generator is operating at rated speed, read the voltage output on a voltmeter. Following this procedure, if the voltage is one-half or greater of rated output and does not fluctuate when there is no load on the generator, the problem is within the voltage regulator. Consult the voltage regulator instruction manual for further information.

## SECTION 8 GENERATOR TESTS

### MEASURING EXCITER FIELD EXCITATION

Exciter field excitation can be measured using a dc voltmeter and dc ammeter connected in the circuit between the voltage regulator dc output and exciter field as shown in Figure 12. The meters must be capable of measuring full load excitation. This will vary according to the size of the generator and can be determined from the test card attached to the generator or by contacting Kato Engineering/Reliance Electric, Mankato, Minnesota. Be sure to provide the generator serial number when requesting information.

#### Procedure

Observe the safety precautions in the Safety Summary at the front of this manual before operating, testing or making repairs to this equipment.

1. Connect dc voltmeter and dc ammeter as shown in Figure 12.
2. Start unit and run at rated speed.
3. Measure no-load excitation. The following abnormal conditions could occur.
  - a. Generator Output Voltage Low, with Normal or Higher than Normal Excitation**  
If this condition occurs, the problem is within the generator or exciter. Test the rotating rectifier diodes and winding resistance.
  - b. Generator Voltage Low and Excitation Low**  
If this condition occurs, the problem is within the voltage regulator or the wiring to the voltage regulator.
  - c. No Generator Voltage and No Excitation**  
If this condition occurs, flash exciter field to restore residual magnetism as described in the procedure given in Section 5 in this manual.
4. Measure excitation with full load applied. The following abnormal conditions could occur.
  - a. Generator Voltage Low and Full-Load Excitation Normal or Higher Than Normal**  
If this condition occurs, verify that speed is not low. Make certain load does not exceed rated full load current given on the generator nameplate.
  - b. Generator Voltage Low and Full Load Excitation Low.**  
If this condition occurs, problem is within the voltage regulator.

### TESTING EXCITER ROTATING RECTIFIER DIODES

Observe the safety precautions in the Safety Summary at the front of this manual before operating, testing or making repairs to this equipment. Refer to Figure 13 for test setup.

Stop generator set. Remove cover located on the end of terminal box. Test as described in the procedure that follows using ohmmeter or three-volt test light.

**NOTE: Where three-volt test light is used: bulb should light when connected in low resistance circuit and should not light when connected in high resistance circuit.**

1. Unsolder wire connected to diode, then remove diode from heat sink (see Figure 3).
2. Measure resistance across diode. Reverse meter probes and again measure resistance.  
A good diode will have low resistance in the normal direction of current flow and high resistance to reverse current. High resistance both forward and reverse indicates diode has become open and should be replaced. Where light is used, failure of bulb to illuminate in both forward and reverse tests indicates an open diode.  
Very low resistance both forward and reverse indicates a shorted diode.  
Where light is used, diode is shorted when light illuminates during both forward and reverse polarity test.
3. Install diode. Torque 15 inch-pounds. Where original diode is replaced, make sure replacement diode is of the same rating and polarity.

4. Solder wire onto diode (see Figures 3 and 11).
5. Repeat steps 1 through 4 until each diode has been tested.

## TESTING SURGE SUPPRESSOR

Observe the safety precautions in the Safety Summary at the front of this manual before operating, testing or making repairs to this equipment.

Refer to Figure 14 for test setup. Stop generator set. Remove cover located on end of terminal box. Disconnect one lead and check with lamp tester. The lamp should not light when the test leads are placed across the surge suppressor in either direction. If the lamp lights, it indicates a shorted surge suppressor. Replace defective surge suppressor with one of the same specifications as the surge suppressor installed at the factory. Order by part number and include the serial number of the generator.

## MEASURING WINDING RESISTANCE

Observe the safety precautions in the Safety Summary at the front of this manual before operating, testing or making repairs to this equipment.

Resistance test of winding may be made to determine whether winding has become open circuited. Resistance measured across a winding that has become open circuited will be very high (near infinity). In the case of shorted turns, resistance will generally be lower than normal. Where shorted turns are suspected, additional test using growler is recommended. Short to ground may be determined by testing winding insulation resistance using a hand cranked 500 VDC megger.

Resistance of winding will vary in proportion to the winding temperature. Where winding temperature is either higher or lower than 25°C (77°F), the formula that follows should be used to compute resistance.

$$\text{Resistance at } 25^{\circ} \text{ C} = \frac{\text{Measured Resistance} \times 234.5 + 25}{234.5 + \text{Winding temp. in } ^{\circ} \text{C}}$$

### A. Measuring Exciter Field Winding Resistance

Test as follows:

1. Stop generator set and remove cover located on end of terminal box.
2. Remove exciter field leads F+ and F- from the F+ and F- terminals on the voltage regulator.
3. Connect ohmmeter onto exciter field leads F+ and F- and measure exciter field winding resistance.
4. Where winding temperature is either high or lower than 25°C, compute resistance as given in the formula contained in preceding topic "Measuring Winding Resistance."
5. Before starting generator set be sure to connect field leads onto voltage regulator terminals F+ and F-. Maintain correct polarity (F+ to F+ and F- to F-).

### B. Measuring Generator Field Winding Resistance

Test as follows:

1. Stop generator set and remove cover located on end of terminal box.
2. Remove generator field leads from the exciter rotating rectifier heat sink (+) and (-) terminals.
3. Connect test instrument such as Wheatstone bridge or Kelvin bridge onto generator field leads and measure generator field winding resistance.
4. Where winding temperature is either higher or lower than 25°C, compute resistance as given in the formula contained preceding topic "Measuring Winding Resistance."
5. Before starting generator set, be sure to connect generator field leads onto the rotating rectifier heat sinks. Maintain correct polarity (positive to + and negative to -).

**C. Measuring Exciter Armature Winding Resistance**

This test requires removing the exciter armature lead wires from the exciter rotating rectifier diodes (refer to Figures 2 and 3).

Test as follows:

1. Stop generator set and remove cover located on end of terminal box.
2. Observe which of the exciter rotating rectifier diodes each of the three exciter armature leads connect to. Then unsolder any two of the three exciter armature lead wires.
3. Measure exciter armature phase-to-phase resistance using test instrument such as Kelvin bridge connected between exciter armature phase 1 lead wire and phase 2 lead wire. Repeat measuring from phase 1 to 3 and again phase 2 to 3.
4. Phase to phase resistances should be quite similar. Where winding temperature was either higher or lower than 25° C, compute resistance as given in formula contained in preceding topic "Measuring Winding Resistance."
5. Before starting generator set be sure to solder leads onto the exciter rotating rectifier diodes (refer to Figures 3 and 11).

**D. Measuring Generator Stator Winding Resistance**

The stator has twelve lead wires brought out from the coil groups permitting connection of the generator stator winding series wye, parallel wye, series delta, parallel delta, or single phase. It is recommended that when testing winding resistance the stator be connected three-phase series wye by connecting the stator leads as shown in Figure 9.

Test as follows:

1. Stop generator set and remove cover located on end of terminal box.
2. Disconnect the twelve generator stator leads numbered 1 through 12 from outgoing load lines, and the leads to voltage regulator, current transformers, and meters.
3. Connect stator leads in series wye configuration as shown in Figure 10 (a).
4. Measure resistance Phase 1 to 2 using a Kelvin bridge. Then measure Phase 1 to 3 and Phase 2 to 3. Phase to phase resistances should be quite similar. Where winding temperature was either higher or lower than 25° C, compute resistance as given in formula contained in preceding topic titled "Measuring Winding Resistance."
5. Connect generator wiring as shown on the wiring diagram provided with the generator set.

**MEASURING WINDING INSULATION RESISTANCE**

Observe the safety precautions in the Safety Summary at the front of this manual before operating, testing or making repairs to this equipment.

The insulation resistance will slowly decrease over the normal life of the generator. Test will indicate abnormal decrease in insulation resistance. Where insulation resistance test is to be made, use a 500 VDC hand cranked megger.

**A. Measuring Generator Stator Winding Insulation Resistance**

1. Stop generator set and remove cover located on end of terminal box.
2. Disconnect wiring from the twelve generator stator lead wires.
3. Connect stator leads in series wye configuration as shown on Figure 10 (a). Be sure to remove neutral lead from ground connection.
4. Connect megger ground lead to generator frame.
5. Connect megger lead onto phase 1 stator lead wire number 1. Make certain no connections other than the megger ground lead are touching the generator frame or other metal parts.
6. Test stator winding insulation resistance. Resistance should not be less than 1.48 megohm. If insulation resistance is lower than minimum value given above, determine cause of low insulation resistance. If due to wet windings, dry out the generator as described in Section 9 in this manual.

7. Before operating generator, connect wiring as shown on the wiring diagram supplied with the generator set. Install covers.

### **B. Measuring Generator Field Winding Insulation Resistance**

Use 500 VDC, hand cranked megger.

Test as follows:

1. Stop generator set and remove cover located on end of terminal box.
2. Disconnect the generator field leads from the (+) and (-) terminals located on the exciter rotating rectifier assembly heat sinks.
3. Connect megger ground lead onto either the generator shaft, fan, or drive hub.
4. Connect megger test lead onto either of the generator field lead wires. Make certain non-insulated lugs on field leads are not touching any generator parts.
5. Measure generator field winding insulation resistance. If the generator field winding insulation resistance is less than one megohm, determine cause of abnormally low insulation resistance. If due to wet windings, dry out generator as described in Section 9 in this manual.
6. Before operating the generator set, connect generator field leads onto exciter rotating rectifier heat sink (+) and (-) terminals (See Figure 3). Install covers.

### **C. Measuring Exciter Field Winding Insulation Resistance**

Test using 500 VDC hand cranked megger as follows:

1. Stop generator set and remove cover located on end of terminal box.
2. Disconnect exciter field leads F+ and F- from the voltage regulator terminals F+ and F-.
3. Connect megger ground lead to the generator frame.
4. Connect megger test lead onto either exciter field lead F+ or exciter field lead F-. Make certain non insulated ends on leads F- and F+ do not touch any metal parts.
5. Measure exciter field winding insulation resistance. If insulation resistance is less than one megohm, determine cause of abnormally low insulation resistance. If due to wet winding, dry out generator as described in Section 9 in this manual.
6. Before operating generator set, connect F+ lead wire onto voltage regulator terminal F+ and lead wire F- onto voltage regulator terminal F-. Install covers.

### **D. Measuring Exciter Armature Winding Insulation Resistance**

Test using 500 VDC megger as follows:

1. Stop generator set and remove cover located on end of terminal box.
2. Using soldering gun, disconnect the three exciter armature lead wires from the exciter rotating rectifier assembly (see Figures 3 and 11).
3. Insulate non-insulated ends on two of the lead wires to prevent grounding during test.
4. Connect megger test lead onto the remaining exciter armature lead wire. Make certain non-insulated connection does not touch any metal part during test.
5. Connect megger ground lead onto either the generator shaft, fan, or drive hub.
6. Measure exciter armature winding insulation resistance. If insulation resistance is less than one megohm, determine cause of abnormally low insulation resistance.
7. Before operating generator set, solder exciter lead wires onto the exciter rotating rectifier assembly (see Figures 3 and 11).

## SECTION 9 DRYING WINDINGS AND REMOVING AND INSTALLING PARTS

### DRYING GENERATOR

An excessive accumulation of moisture on the generator windings can reduce the winding insulation resistance. The recommended stator winding insulation resistance test procedure and the minimum allowable insulation resistance is described in Section 8 in this manual.

Where moisture is present and test indicates insulation resistance does not exceed the minimum standard, thoroughly dry out the generator before operating the machine. The following are recommended drying methods.

#### A. Heat Enclosure

Remove the generator cover. Enclose the generator and insert heating units such as space heaters, lamps, or coils of steam pipe to raise the temperature. Leave a hole at the top of the enclosure to permit the escape of moisture. Temperature within the enclosure should not exceed 93 degrees C or 200 degrees F. The voltage regulator and any electronic components must be removed from the generator when using this method.

#### B. Forced Air

A portable forced air heater can be used to direct heat into the exciter end of the generator through openings in the endbell. Heat at point of entry should not exceed 93 degrees C or 200 degrees F.

#### C. Oven

Place the machine in a thermostat controlled oven and bake it at a temperature not to exceed 93 degrees C or 200 degrees F. The voltage regulator and any electronic component accessories must be removed from the generator when using this method.

### REMOVING GENERATOR FROM ENGINE

During this procedure be sure to follow the handling precautions described in Section 2 in this manual. Parts are shown on Figures 1 and 2.

1. Remove cover located on end of terminal box and disconnect incoming electrical cables.
2. Loosen cover that surrounds generator frame. Remove drip proof cover and screen from the adaptor located at driven end of generator.
3. Disconnect the generator field leads from the (+) and (-) terminals on the exciter rotating rectifier.
4. Remove exciter rotor retaining bolt from end of generator shaft.
5. Pull exciter rotor off generator shaft. Do not pull on the rectifier assembly or windings.

**NOTE: If exciter rotor cannot easily be removed by hand, a 1/4 20 bolt can be threaded into the tapped hole next to the exciter rotor. This action will push the exciter rotor off the shaft.**

6. Remove rectangular key from keyway in shaft. Keep key with the exciter armature.
7. Install lifting eye(s) in tapped hole(s) located in the top of the generator frame.
8. Remove bolts that mount the generator onto the generator set base.
9. Where additional space is required to remove coupling bolts, remove fan as follows:
  - a. Measure and record distance from the drive plates to the fan. Fan must be located at this distance when it is re-installed
  - b. Remove bolts that hold the fan half-sections together, then remove fan.
10. Where engine does not have rear mounting pads, be sure to support engine flywheel housing.
11. Support generator rotor. This may be done by installing (a) a cable around the generator drive hub and attaching cable to a hoist, (b) jack or blocking under the drive hub, or (c), thin wooden or fiber strips in the generator air gap.

**NOTE: Where blocking will be placed in the rotor air gap it may be necessary to either remove fan or loosen wrapper cover in order to install rotor support blocking in the air gap.**

12. Remove bolts that mount the generator adaptor face onto the flywheel housing.

13. Remove bolts that mount the generator drive plates to the driving ring recess in the flywheel.
14. Attach hoist onto lifting eyes.

### **CAUTION**

**Excessive axial misalignment of the rotor can result in equipment damage.**

15. Carefully move generator away from the engine flywheel housing and the flywheel. Make certain that drive plates do not bind in flywheel driving ring recess. If the drive plates bind, bearing may be pulled out of the bearing housing.
16. Where rotor was supported by cable and hoist or jack or block under drive hub, remove support from drive hub and follow step 17.
17. Install block across generator adaptor and drive plates. Bolt to adaptor and drive plates to support rotor while transporting the generator.
18. Carefully lift generator off generator set base.

Follow the procedures contained in Section 3 in this manual when mounting generator on the generator set base and coupling the generator to the engine.

## **REMOVING AND INSTALLING EXCITER ROTOR**

The exciter rotor, Figure 2, consists of the exciter armature and the full-wave rotating rectifier assembly. The assembly mounts on an extension of the generator shaft that protrudes beyond the generator endbell. The exciter rotor assembly is held in place on the shaft by a rectangular key on the shaft and a bolt and washer on the end of the shaft. The inside surface on the exciter armature core is pushed against a raised shoulder on the generator shaft.

### **A. Removing the Exciter Rotor**

1. Remove cover located on end of generator terminal box.
2. Disconnect the generator field leads from the rotating rectifier (+) and (-) terminals.
3. Remove exciter retaining bolt from end of generator shaft.

**NOTE:** If exciter rotor cannot easily be removed by hand, a 1/4 20 bolt can be threaded into the tapped hole next to the exciter rotor. This action will push the exciter rotor off the shaft.

### **CAUTION**

**Do not pull on or strike the exciter armature windings.**

4. Pull exciter rotor assembly off generator shaft. Pull rectangular key out of the keyway in shaft and keep it with the exciter rotor assembly.

### **B. Installing Exciter Rotor**

1. Install rectangular key in keyway located in generator shaft.
2. Align keyway in the exciter armature core with the key and push exciter rotor onto shaft. **DO NOT PUSH OR STRIKE WINDING OR RECTIFIER. MAKE SURE INSIDE EDGE ON ARMATURE CORE IS AGAINST RAISED SHOULDER ON SHAFT.**
3. Install exciter retaining bolt on end of shaft. Torque 1/2 inch bolt to 60 foot-pounds.
4. Check exciter air gap. Air gap should not be less than that listed in Table 4. Check to make certain exciter armature core and the exciter field core are axially aligned.
5. Connect generator field leads onto rotating rectifier (+) and (-) terminals (refer to Figure 11).
6. Install cover on terminal box.

## **REMOVING AND INSTALLING TERMINAL BOX AND ENDBELL**

These parts must be removed to service or replace the bearing or when removing the generator rotor. Be sure to

follow the handling precautions described in Section 2 in this manual. Parts are shown on Figures 1 and 2.

#### **A. Removing the Terminal Box and Endbell**

1. Remove the side covers and the louvered end cover from the terminal box.
2. Disconnect incoming electrical cables and conduit. Disconnect stator leads.
3. Disconnect electrical wiring from voltage regulator and other controls mounted within the terminal box.
4. Remove the exciter rotor, comprised of the exciter armature and rotating rectifier assembly. Follow the steps given in procedure titled "Removing the Exciter Rotor."
5. Remove fiber wire retaining ring.
6. Remove parts that mount onto the back plate of the terminal box and the endbell.
7. Remove cover that surrounds the generator frame.
8. Place rotor support blocking in the generator air gap.
9. Remove bolts that mount the terminal box and the endbell onto the generator frame.
10. Remove terminal box.
11. On larger generators, attach hoist onto endbell. Take up slack but do not lift generator.
12. Pry endbell loose from pilot recess located in the frame endring.
13. Pull endbell straight back to position where bearing outer race is out of the bearing housing at the center of the endbell.
14. Remove endbell.
15. Some units may have circular fiber spacers located in the bearing housing section of the endbell. If this is the case, be sure to install spacers when reinstalling endbell.
16. Inspect and clean rust and dirt from the mounting face on endbell and the bearing housing. Remove any metal burrs.
17. Wipe a thin coat of grease in the bearing housing section of the endbell.

#### **B. Installing Terminal Box and Endbell**

During this procedure be sure to follow the handling precautions described in Section 2 in this manual. Refer to Figure 1 and the wiring diagram provided with the generator set.

1. Where generator was provided with circular spacers in the bearing housing section of the endbell, install the spacers.
2. Inspect to make certain bearing housing and mounting face on endbell is free of rust, dirt, and metal burrs.
3. Wipe thin coat of grease in bearing housing section in endbell.
4. Lift endbell into alignment with the bearing and carefully push bearing housing section on endbell over the outer race of the bearing.
5. Place endbell over end of shaft and turn endbell to position where lead wire hole in endbell aligns with lead wires. Pull stator leads through opening in the endbell. Make certain generator field leads are along wireway on shaft.
6. Push endbell bearing housing over the bearing outer race.
7. Mount terminal box and endbell onto the generator frame using hex head bolts and washers. Watch to make certain endbell fits evenly into pilot recess, and sequentially tighten bolts. Torque bolts according to recommended torque for SAE 5 cap screws given in Table 2.
8. After generator has been coupled to the prime mover, remove rotor support blocking from generator air gap.
9. Install fiber wire retaining ring.
10. After generator has been coupled to the prime mover, install the exciter rotor as described in procedure titled "Installing Exciter Rotor."
11. Mount voltage regulator and controls.
12. Connect electrical wiring according to appropriate wiring diagram.
13. Before operating generator set, check to make certain unit is connected correctly and terminals are tight and insulated.
14. Remove tools and shop cloths.
15. Install covers and guards.

## REMOVING AND INSTALLING BEARING

If the bearing needs to be removed for any reason, always install a new bearing. Remove and install bearing according to the general procedure that follows. Be sure to follow the handling precautions described in Section 2 in this manual.

1. Disconnect wiring and remove the exciter rotor, terminal box, and endbell. Refer to the preceding "Terminal Box and Endbell Removal" instructions and procedure titled "Removing the Exciter Rotor."
2. Remove fiber wire retaining ring.
3. Remove bearing with suitable puller.
4. Apply a thin coat of clean lubricating oil or anti-seize lubricant to the pressure fit on the rotor shaft.
5. Heat the new bearing in an oven to a maximum temperature of 225°F.

### CAUTION

**Under no circumstances should pressure be applied to the outer race of the bearing, as permanent bearing damage could result.**

6. Make certain generator field leads are in proper position in the wireway along the generator shaft. Then using asbestos gloves, install the bearing over the end of the shaft. Using metal or fiber pipe with I.D. larger than the shaft, push against bearing inner race until bearing seats against the raised shoulder.

**NOTE: The bearing should slide on the shaft and be seated without excessive force. If the bearing binds on the shaft before being fully seated, a piece of tubing slightly larger than the shaft diameter can be placed over the shaft and the bearing can be slid in place by tapping lightly on end of tubing with a soft mallet. Care must be taken to ensure pressure is applied to the inner race only.**

7. Allow bearing to cool.
8. Install endbell and terminal box. Follow the "Endbell and Terminal Box Installation" instructions.
9. Remove rotor support blocking from air gap.
10. Install fiber wire retaining ring.
11. Install exciter rotor as described in procedure titled "Installing the Exciter Rotor."
12. Mount parts in terminal box and connect wiring as shown on the wiring diagram supplied with the generator set.
13. Remove tools and shop cloths.
14. Install covers.

## REMOVING AND INSTALLING GENERATOR ROTOR

Generator parts are shown on Figure 1.

Be sure to follow handling precautions described in Section 2 in this manual. Rotor may be removed as described in the procedure that follows. **BE EXTREMELY CAREFUL TO MAINTAIN CLEARANCE BETWEEN METAL PARTS AND WINDINGS.**

### A. Removing Rotor

1. Disconnect power and remove incoming electrical cable and conduit. Disconnect generator ground wire.
2. Remove end and side covers from terminal box.
3. Remove exciter rotor as described in the procedure titled "Removing the Exciter Rotor."
4. Install wooden rotor support blocking in the generator air gap.
5. Disconnect wiring and remove the voltage regulator and other parts mounted within the terminal box.

**NOTE: Where a clear space approximately the same distance in length as the generator exists beyond the outboard or exciter end of the generator, unit need not be removed from the generator set base. If this is the case, and stator repair is not required, proceed to step 8.**

6. Remove generator from the engine as described in procedure titled "Removing Generator From Engine." Be sure to follow precautions contained in Section 2 in this manual.

7. Transport generator to area that provides sufficient room for rotor removal through exciter end of unit. Approximately the same distance as length of generator must exist beyond exciter end of unit. Be sure to follow handling precautions contained in Section 2 in this manual.
8. Remove generator covers.
9. Remove fiber wire retaining ring.
10. Remove terminal box and endbell as described in the "Terminal Box and Endbell Removal" instruction. Be sure to follow handling precautions contained in Section 2.
11. Remove drive plates from the drive coupling hub.
12. Remove fan as follows:
  - a. Measure from inside face on coupling hub to outside face on fan hub. Record this distance. Fan must be positioned according to this measurement when it is reinstalled.
  - b. Remove bolts that secure the fan half-sections together, then remove fan.
13. Bend 16 gauge or heavier sheet metal to fit in air gap and extend beyond frame endring or use several plywood strips or wood that will extend through air gap and out past the frame endring.
14. Lift both ends of the rotor slightly and insert the blocking described in step 12. Be sure to maintain air gap.
15. Place blocks between the blocking and frame endring at the exciter end. Blocks should be of sufficient height to keep strips clear of windings.
16. Lower generator rotor onto blocking.
17. Carefully slide rotor part way out through exciter end of unit.
18. After rotor has been placed in position where field (rotor) poles are partially beyond frame endring, proceed to next step.
19. Attach cable around exciter field poles be careful to keep cable away from windings.
20. Attach hoist onto cable and, while balancing rotor, move generator rotor out of stator. Be careful to maintain air gap.

#### **B. Installing Rotor**

Installation procedure, in general, is the reverse of removal procedure. Torque bolts according to recommended torque for SAE 5 cap screws shown in Table 2. Be sure to position fan according to measurement made during removal procedure step 11. Be sure to follow precautions given in Section 2 in this manual. Follow alignment in section and measurements contained in Section 3.

## **INSTALLING REPLACEMENT SURGE SUPPRESSOR**

Refer to Figure 3.

To remove defective surge suppressor: Use a screwdriver to loosen surge suppressor lead connections on the heat sinks. Pull leads free. Remove surge suppressor disk from slot on rectifier hub. Removal may be difficult as surge suppressor is secured with silicone rubber adhesive.

To install replacement surge suppressor: Install disk of surge suppressor in slot on rectifier hub and secure with silicone rubber adhesive. Take care not to block the tapped hole on the rectifier plate near the surge suppressor slot. Attach surge suppressor lugs to connections on the heat sinks and tighten connections.

## SECTION 10 FIGURES AND TABLES

### GENERAL

The drawings, electrical schematics, and tables contained in this section are included to aid in the installation and maintenance of this equipment. The overall electrical connection diagram supplied with the generator set should be followed when connecting the stator lead wires, voltage regulator, and any other operating controls provided with this unit.

**Table 1  
Generator Voltage - Standard Kamag Generators**

Connection (See Note)	Voltage Range (By Adjustment of voltage control rheostat)	
	50 Hertz	60 Hertz
3 Phase series wye (Phase-to-Phase)	340 to 400	408 to 490
3 Phase parallel wye (Phase-to-Phase)	170 to 200	204 to 245
3 Phase series delta (Phase-to-Phase)	196 to 230	236 to 283
Single Phase 3 wire (Line-to-Line)	196-230	236 to 283

**NOTE:** Phase-to-neutral voltage for 3-phase wye connections are 58% of line-to-line voltages listed.  
Line-to-neutral voltage for 3 wire single phase is one-half the line-to-line voltage listed.

**Table 2  
Recommended Torque SAE 5 Steel and SAE 8 Steel Cap Screws**

Shank Diameter (in inches)	Recommended Torque (in foot pounds)	
	A.S.T.M. A449 S.A.E. 5 Steel	S.A.E. 8 Steel
1/4	9	13
5/16	18	28
3/8	31	46
7/16	50	75
1/2	75	115
9/16	110	165
5/8	150	225
3/4	250	370
7/8	378	591
1	583	893
1 1/8	782	1410
1 1/4	1097	1964
1 3/8	1461	2633
1 1/2	1748	3150

**Table 3**  
**Dimensions of Flywheels-Inches**  
**(SAE Standard for Flywheels for Industrial Engines used for**  
**Drive Ring Type Overcenter Clutches and Engine Mounted Marine Gears - SAE -J620c)**

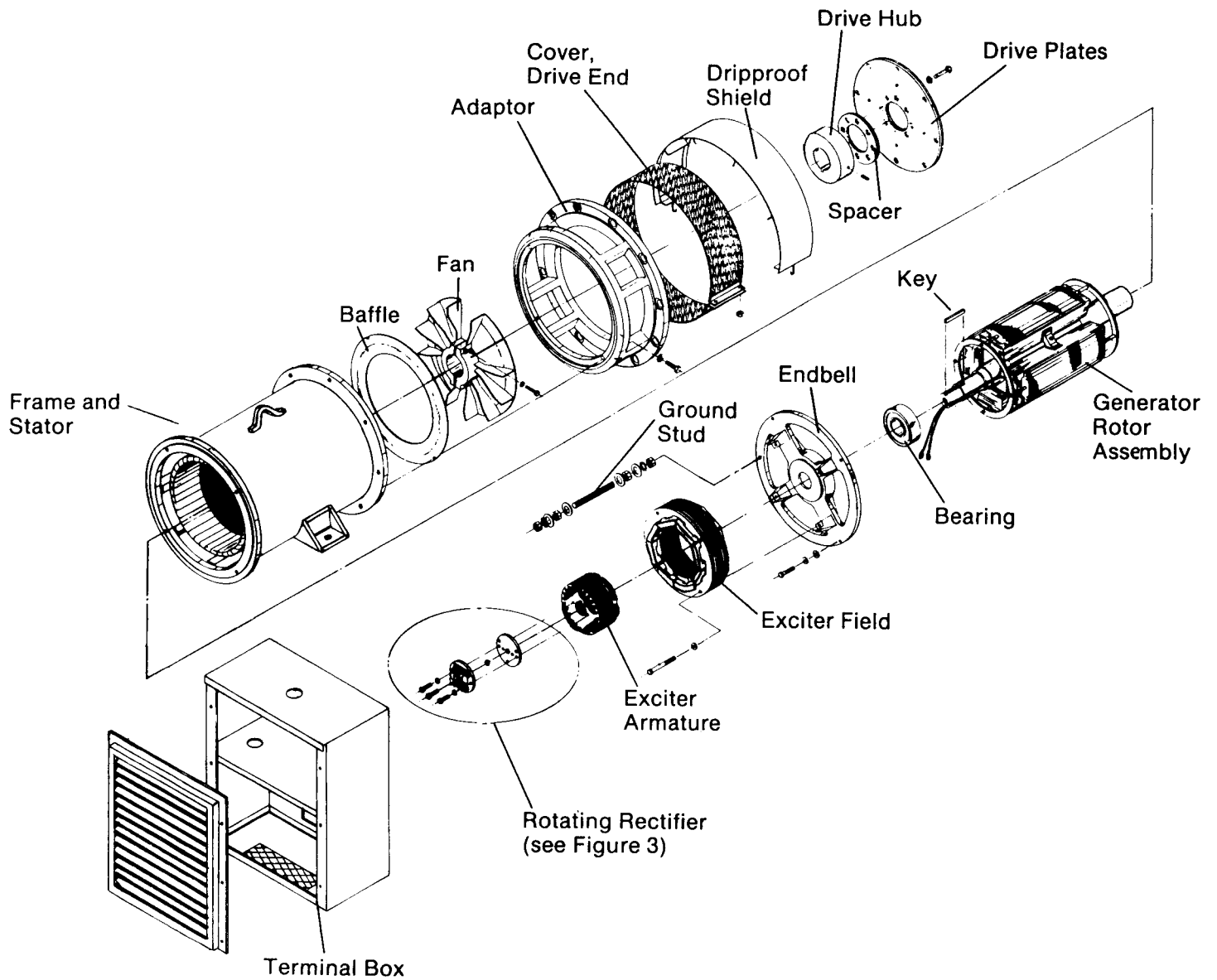
Nominal Clutch Diameter	B see notes a,b	C	G	L see notes b,c	Tapped Holes (see note d)	
					No.	Size
6 1/2	8.500	7.875	1.19	2.0472	6	5/16-18
7 1/2	9.500	8.750	1.19	2.0472	8	5/16-18
8	10.375	9.625	2.44	2.4409	6	3/8-16
10	12.375	11.625	2.12	2.8346	8	3/8-16
11 1/2	13.875	13.125	1.56	2.8346	8	3/8-16
14	18.375	17.250	1.00	3.1496	8	1/2-13
16	20.375	19.250	0.62	3.9370	8	1/2-23
18	22.500	21.375	0.62	3.9370	6	5/8-11
21	26.500	25.250	0	5.1181	12	5/8-11
24	28.875	27.250	0	5.1181	12	3/4-10

**NOTE:**

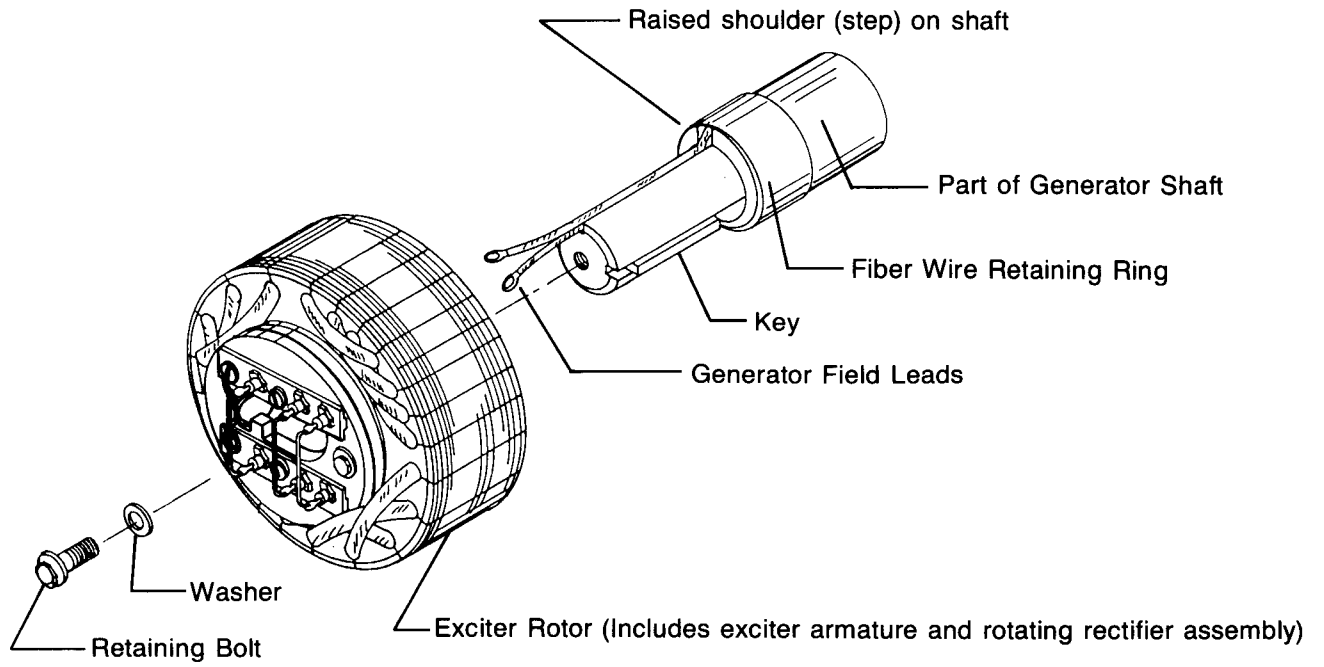
- Diameter tolerance of driving ring pilot bore B is plus 0.005, minus 0.000; maximum eccentricity is 0.005 total indicator reading (see footnote b); face runout is 0.0005 maximum total indicator reading per inch of diameter.
- Eccentricity between driving ring pilot bore B and pilot bearing bore L is not to exceed 0.008 total indicator reading.
- K is length of bore for pilot bearing; L is nominal diameter of bearing. Diameter and fit are to suit installation. Maximum eccentricity is 0.005 total indicator reading (see footnote b).
- Tapped holes should be threaded in accordance with UNC Class 2B tolerances of the SAE Standard, Screw Threads-SAE J475.

**Table 4**  
**Minimum Air Gap for Kato Brushless Exciter**

Exciter Rotor (Armature) Diameter (in inches)	Minimum Air Gap (in inches)
5 3/4	0.014
9 7/8	0.014
12/ 1/2	0.018
16 1/4	0.035

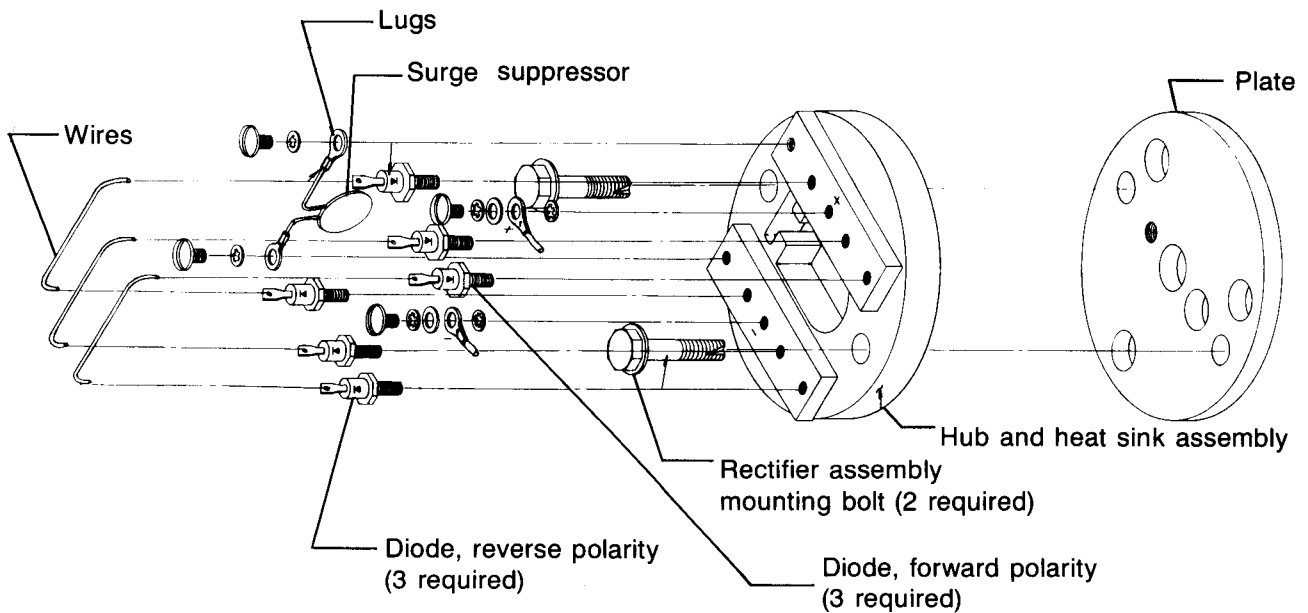


**Figure 1 Single Bearing Kamag Generator With Outboard Exciter**

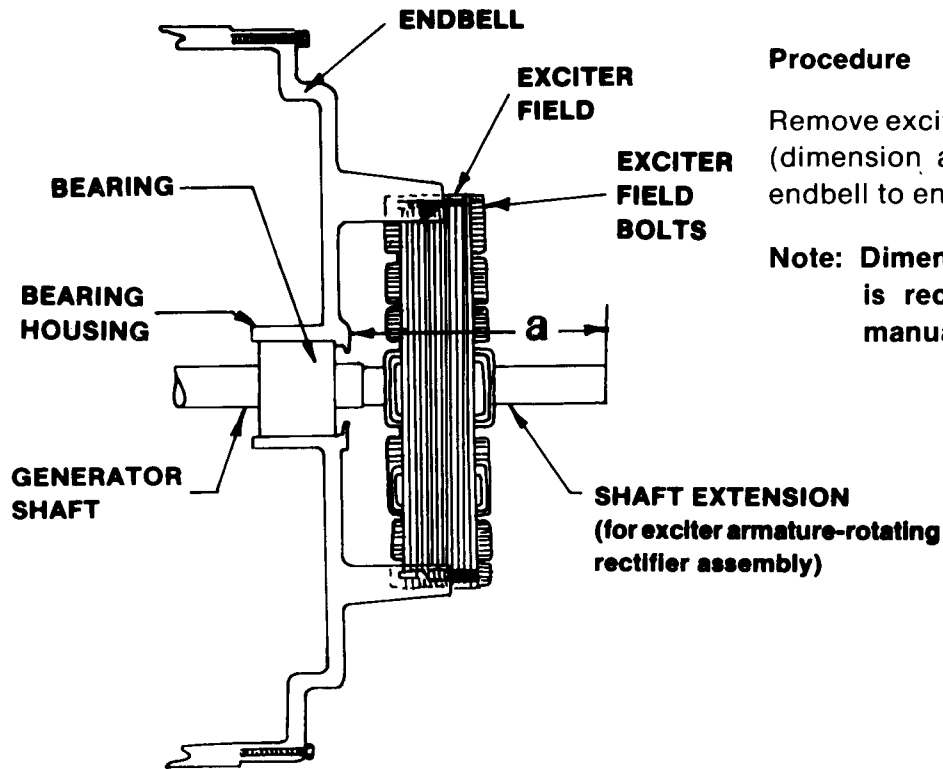


**Figure 2 Exciter Rotor Installation**

**NOTE: Exciter and Generator Field Interwiring is shown on Figure 11.**



**Figure 3 Rotating Rectifier**

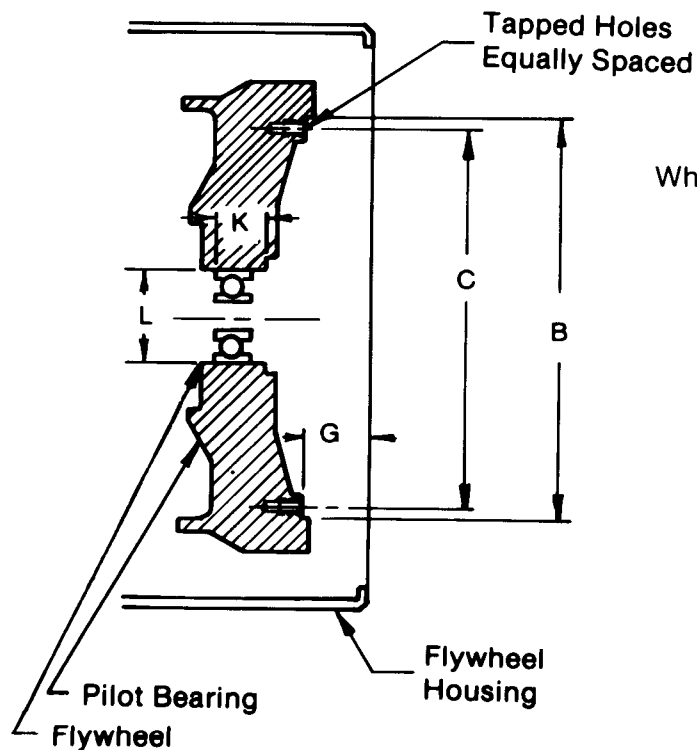


#### Procedure

Remove exciter rotor unit. Measure length (dimension a) from bearing housing on endbell to end of shaft.

**Note:** Dimension (a) measured at factory is recorded in section 1 in this manual.

Figure 4 Extension of Generator Rotor Shaft For Mounting of Exciter Rotor Assembly



Where: B= Driving Ring Pilot Bore Diameter  
 C= Hole Centers  
 G= Depth from flywheel housing face  
 L= Pilot Bearing Bore  
 K= Length of bore for pilot bearing

**Note:** G measured from face on flywheel housing with tapped holes

See Table 3

Figure 5 SAE Flywheel

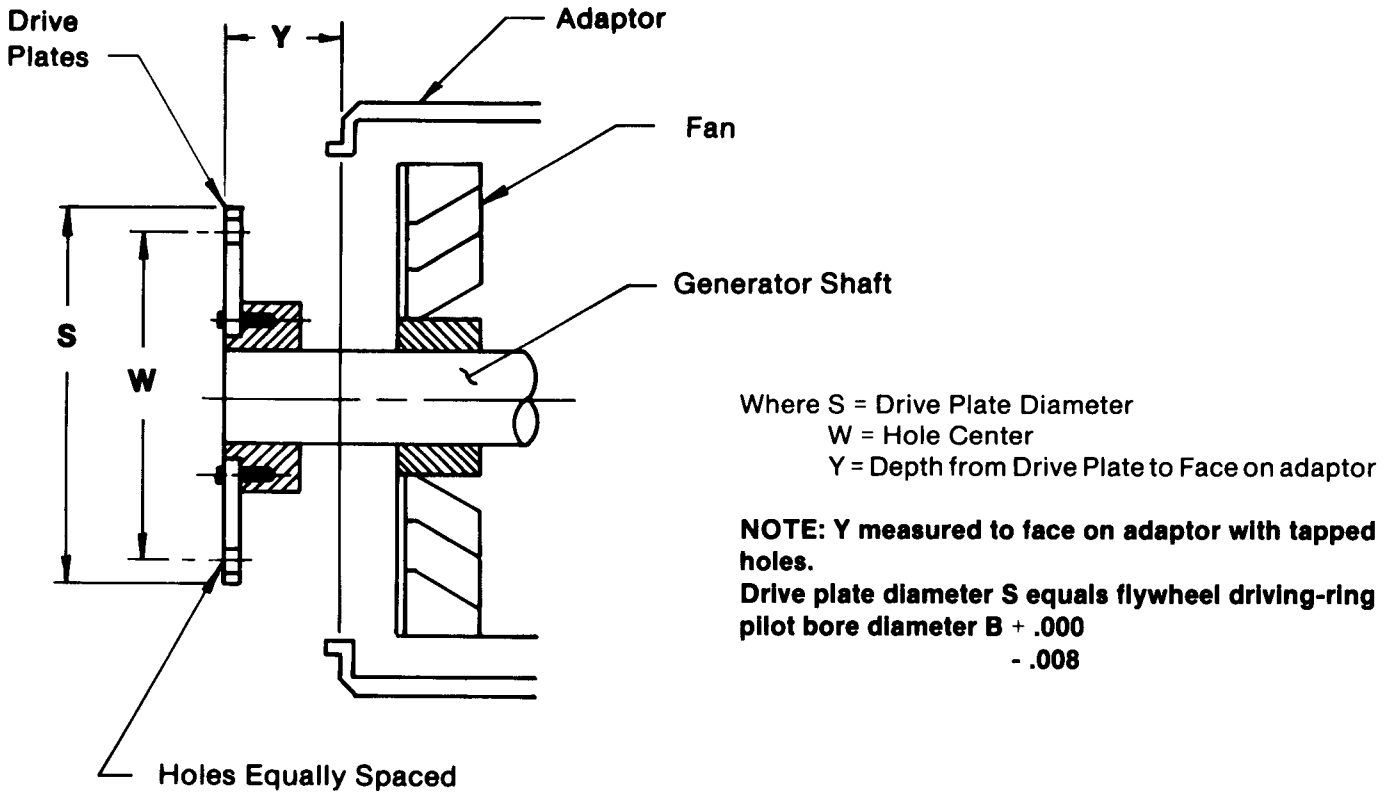


Figure 6 Single Bearing Generator Adaptor and Drive Plates

**RECOMMENDED PROCEDURE**

Torque bolts in sequence according to bolt pattern.

Then check torque in each bolt in clockwise direction around the bolt circle to ensure all bolts are properly torqued.

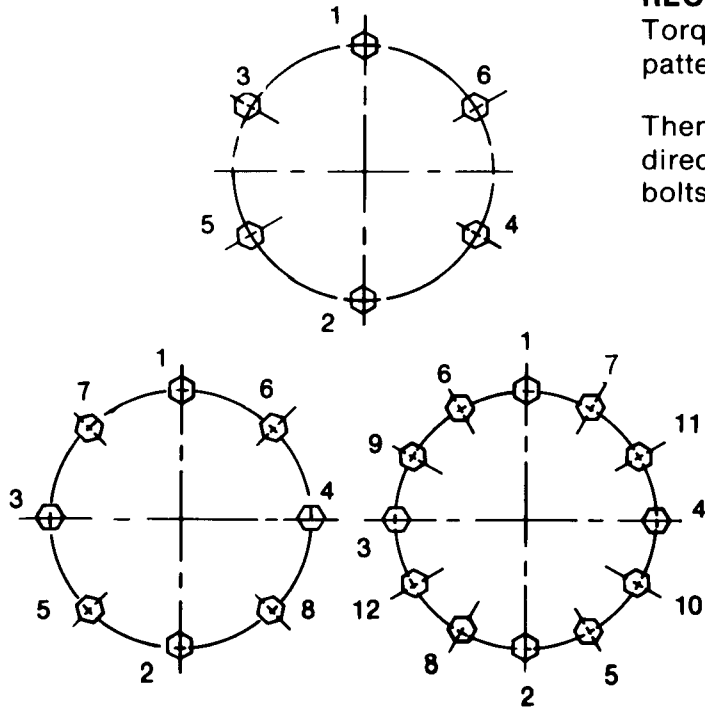
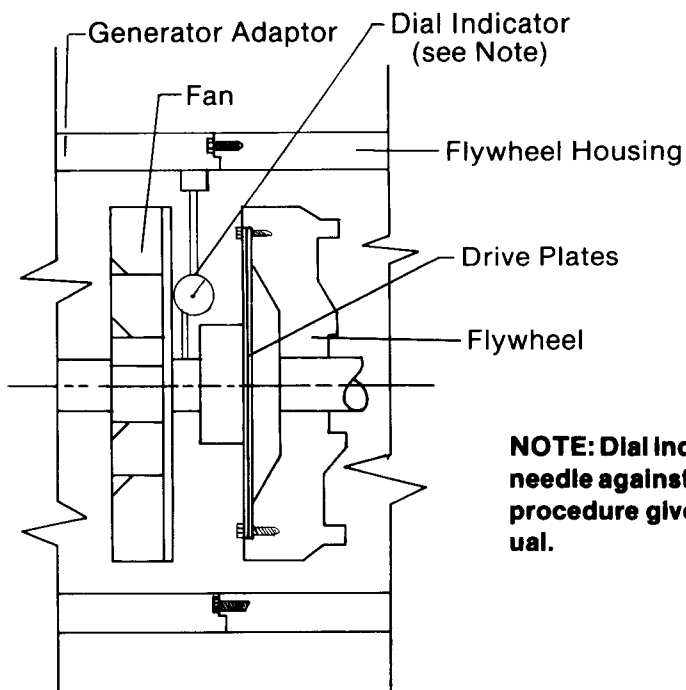
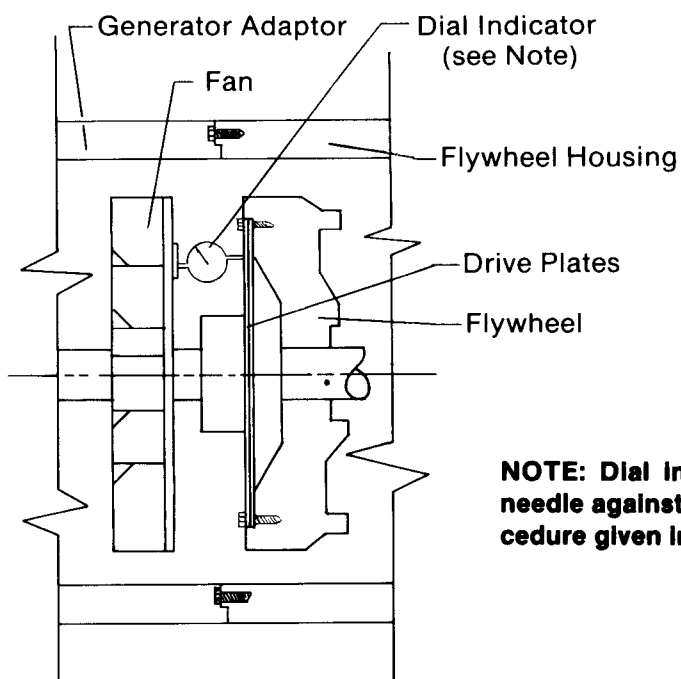


Figure 7 Recommended Torque Sequence For Circular Bolt Pattern



**NOTE: Dial indicator base on adaptor and needle against shaft or drive hub. Refer to procedure given in Section 3 in this manual.**

**Figure 8 Checking Rotor Eccentricity**



**NOTE: Dial indicator base on fan and needle against drive plates. Refer to procedure given in Section 3 in this manual.**

**Figure 9 Checking Angular Alignment**

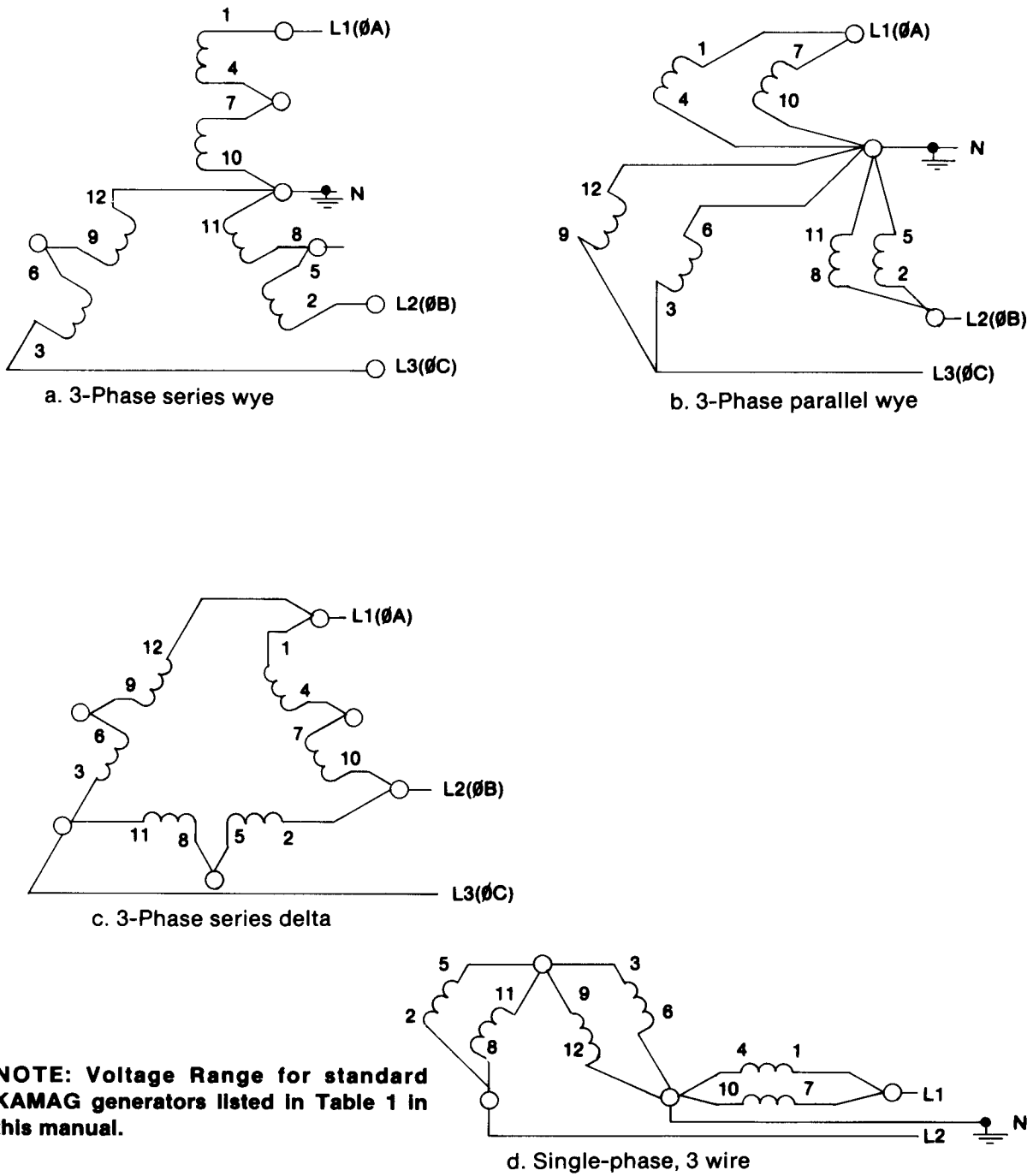
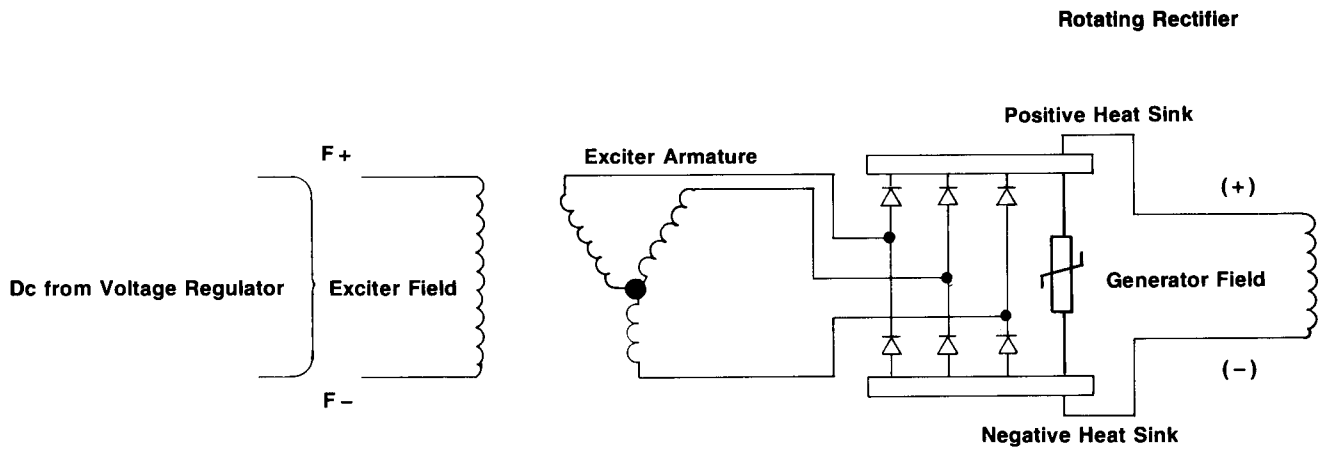


Figure 10 Twelve Wire Generator Stator Lead Wire Connection Diagram

**CAUTION**

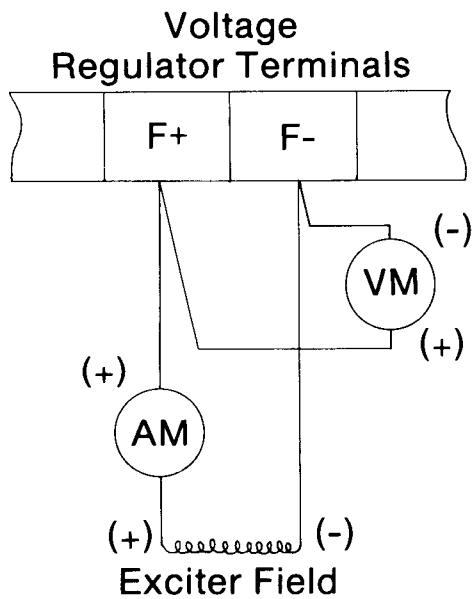
This drawing does not show interconnection for voltage regulator and other controls that could be provided with the generator set. Be sure to follow the wiring diagram provided with the generator set when making electrical connections.



**NOTE**

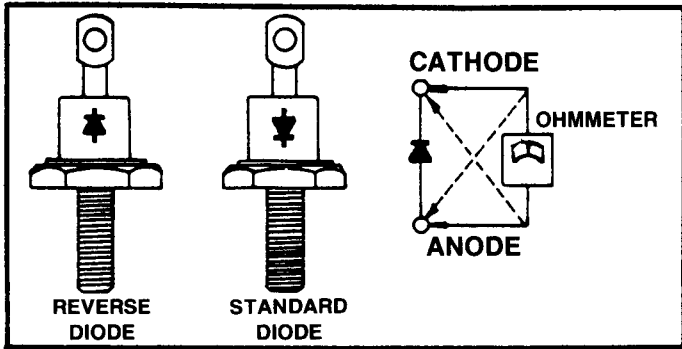
Three forward polarity diodes are mounted on the positive heat sink, and three reverse polarity diodes are mounted on the negative heat sink. A surge suppressor is mounted across the heat sinks.

**Figure 11 Exciter and Generator Field Interconnection**

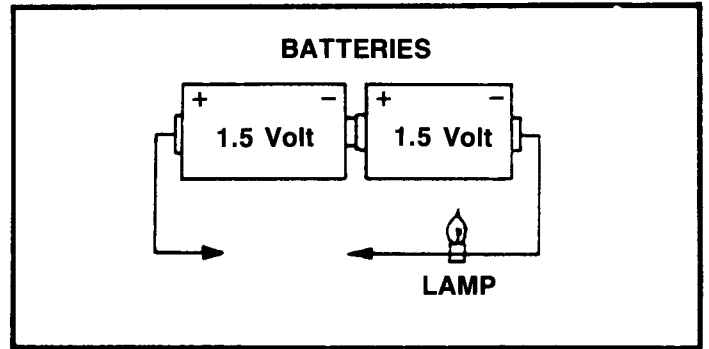


**NOTE: Use dc voltmeter and dc ammeter with scale equal to or more than the one-minute field forcing capacity given in the voltage regulator instruction manual.**

**Figure 12 Field Excitation Measurement Meter Connection Diagram**



**Figure 13 Testing Rotating Rectifiers with an Ohmmeter**



**Figure 14 Testing Surge Suppressor with a Test Lamp**





# WARRANTY

---

Kato Engineering warrants that its products will perform as specified in bonafide quotations or Kato publications, providing such products are properly installed, properly cared for, and properly operated under normal environmental conditions.

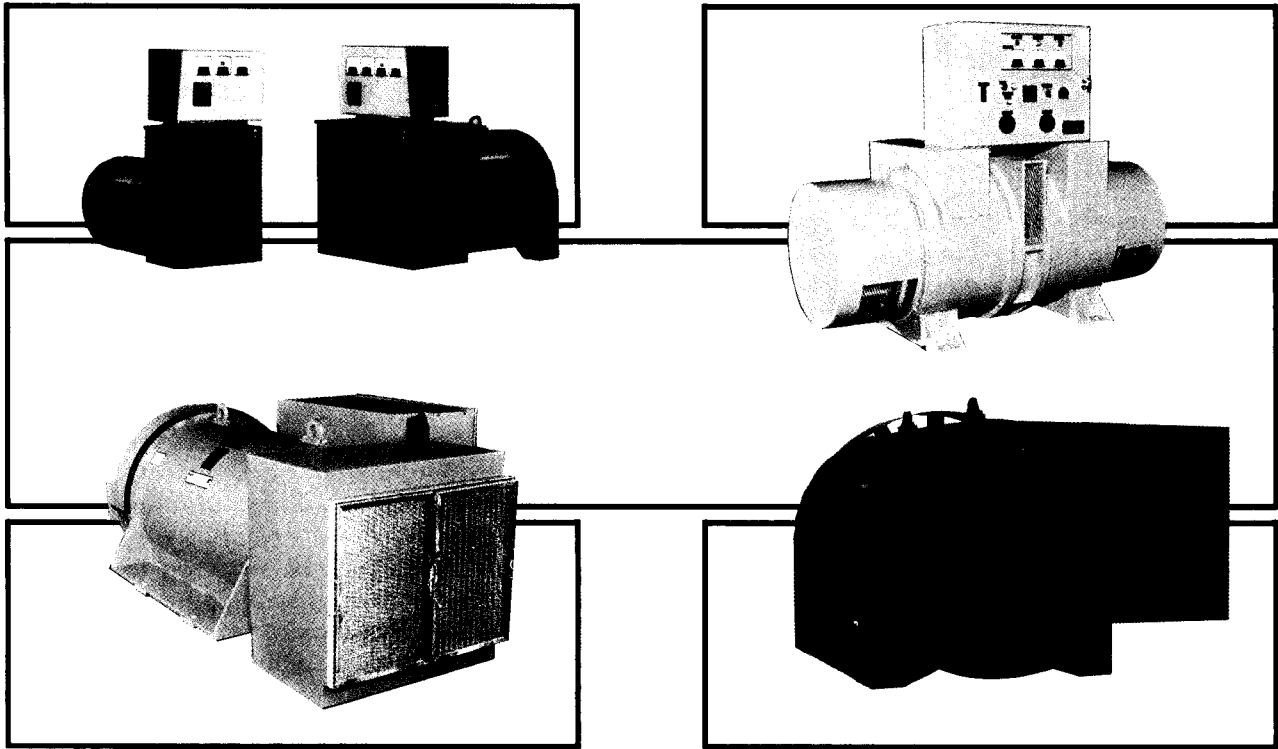
Standard products manufactured by Kato Engineering are warranted to be free from defects in workmanship and material for a period of one year in operation or 18 months from date of shipment, and any products which are defective in workmanship or material will be repaired or replaced at the option of Kato Engineering. Final determination as to whether a product is actually defective rests with Kato Engineering. The obligation of Kato Engineering hereunder shall be limited solely to repair and replacement at its factory, of products that fall within the foregoing limitations and shall be conditioned upon receipt by Kato Engineering of written notice within the warranty period of any alleged defects or deficiency. No products shall be returned to Kato Engineering without its prior consent. In no case will Kato Engineering accept shipping charges incurred either through return of defective items to its factory or return of repaired or replacement items to the user. Kato Engineering cannot assume responsibility or accept invoices for unauthorized repairs to its components even though defective. In the case of components, parts or units purchased by Kato Engineering the obligation of Kato Engineering shall not exceed the settlement that it is able to obtain from the supplier thereof.

**The life of the products of Kato Engineering depends to a large extent upon the type of usage. Kato Engineering makes no warranty as to period of service nor as to fitness of its products for specific applications by the buyer. In no event will Kato Engineering be liable for consequential or incidental damages or any expense incurred by the Buyer due to use or sale of products sold by Kato Engineering.**

**The foregoing warranty is exclusive and in lieu of all other warranties expressed or implied, including but not limited to any warranty of merchantability or of fitness for a particular purpose.**

**This Warranty does not apply to experimental or developmental products.**

# DEPENDABLE ELECTRICAL POWER EQUIPMENT BUILT TO PRECISE SPECIFICATIONS



**Assured Power Performance for Any Energy System**

Prime Power

Emergency / Standby Power

Co-Generation

Load Isolation and Frequency Conversion

For quality products from 5 - 13,000 kW  
contact Kato Engineering.

**Kato Engineering**



P.O. BOX 8447  
MANKATO, MN 56002-8447  
(507) 625-4011  
FAX (507) 345-2798