

INSTRUCTION MANUAL

Installation Instructions,
Operating Procedures and
Maintenance Instructions for
Voltage Regulators
Part Number
800-84132-07
800-84132-11

TABLE OF CONTENTS

Section 1 Introduction and Theory of Operation

	Page No.
Introduction	1-1
Theory of Operation	1-1

Section 2 Installation

Safety Summary	2-1
Location	2-1
Mounting	2-1
Electrical Connections	2-1

Section 3 Controls Adjustment Procedures and Voltage Regulator Operating Procedures

Safety Precautions	3-1
Voltage Regulating System Controls	3-1
Operating Procedures	3-1

Section 4 Maintenance

Safety Summary	4-1
Preventive Maintenance Inspection	4-1
Troubleshooting Procedures	4-1
Table 4-1 Troubleshooting Chart	4-1
Isolating System Malfunction to either the Voltage Regulator or the Generator by Measuring Field Excitation	4-4
System Malfunction Trouble Isolation by using Manual Voltage Control to Provide Field Excitation	4-4
Voltage Regulator Test	4-6
Voltage Regulator Component Test Procedures	4-6

Section 5 Parts Lists and Drawings

Table 5-1 Static Exciter Regulator Parts List	5-1
Fig. 5-1 Regulator Outline Drawing	5-1
Fig. 5-2 Regulator Electrical Schematic	5-2
Fig. 5-3 Circuit Board Schematic	5-3
Fig. 5-4 Circuit Board Outline Drawing	5-4

SECTION 1

INTRODUCTION AND THEORY OF OPERATION

INTRODUCTION

The magnetic amplifier voltage regulator is designed to operate with brushless synchronous 400 Hz generators. The voltage regulator controls generator voltage by regulating the amount of current it supplies the exciter field.

SPECIFICATIONS

Input Power: single phase, 400 Hz, 120 Vac
 Sensing: single phase, 400 Hz, 208-240 Vac
 Output: continuous maximum: 63 Vdc, 3.5 amperes
 Output: one minute field forcing: 90 Vdc, 5 amperes

THEORY OF OPERATION

Note: Refer to drawings 5-2 and 5-3.

A. Sensing

A sample of the generator output voltage is applied to regulator sensing terminals E1 and E2 (Fig. 5-2). This voltage is applied to sensing transformer T1 which proportionally reduces the voltage to about 1/10 of that across terminals E1 and E3. Regulators equipped for parallel operation also include transformer T2. This circuit does not affect voltage regulator operation in single unit operation if the CT leads are shorted. (See B below.)

The reduced ac voltage is then fed to a rectifier consisting of diodes D1 through D4 (Fig. 5-3). The rectifier output, which is proportional to the sensing voltage, is filtered by capacitor C1 and choke L1. It is then impressed across a voltage divider circuit consisting of resistors R2 and R4, voltage range set adjust potentiometer R3, and the externally mounted voltage adjust rheostat. A portion of this voltage is applied to the base of transistor Q1 in the error detector circuit.

B. Sensing Circuit During Parallel Generator Operation in Parallel Cross-Current Compensation Mode

Parallel cross-current compensation allows two or more parallel generators to share reactive loads and maintain constant system output voltage. The reactive error signal developed in the external paralleling circuit is added vectorially to the sensing voltage by transformer T2. The circuit is phased such that a generator with excessive excitation will decrease excitation and an underexcited generator will increase excitation. At balance, each generator will carry its share of reactive load.

C. Error Detector

The error detector is a differential amplifier. Resistors R11 and R14 in the emitter circuit of transistors Q1 and Q2 are of equal value. Therefore, when the base voltage of Q1 is equal to the base voltage at transistor Q2, Q1 and Q2 conduction will be equal. Transistor Q2 is the reference voltage side of the error detector. Its base voltage is kept constant by zener diode Z1. The base voltage of Q1 is proportional to the sensing voltage and the setting of the voltage adjust rheostat. Q1 base voltage will therefore increase and decrease in direct proportion to any increase or decrease in the sensing voltage or change in the setting of the voltage adjust rheostat. Operation of the error detector (Q1, Q2), second stage differential amplifier (Q3, Q4), and amplifier Q5, Q6 is as follows.

An increase of Q1 base voltage will decrease Q1's collector voltage and increase Q2's collector voltage. The differential collector voltage is directly connected to the bases of Q3 and Q4. This voltage increases Q3's collector current and decreases Q2's collector current. The increase in Q3's collector current is also an increase in base drive to the control current amplifier transistors Q5 and Q6. The collector current of Q5 and Q6 and the magnetic amplifier control current increases, resulting in decreased magnetic amplifier output. Conversely, a decrease in sensing voltage results in lower conduction of transistors Q1, Q3, Q5, and Q6, a decrease in control current and an increase in magnetic amplifier output.

D. Power Stage

The output power stage of the voltage regulator (Fig. 5-2) rectifies 400 Hz power and feeds a regulated amount of dc power to the exciter field. The power output stage consists of an electromagnetic filter (RFI), two full-wave rectifiers (BR1 and BR2) and two toroid magnetic amplifiers (MA-1 and MA-2). The magnetic amplifiers contain two windings wound about a ferromagnetic core. The windings are: a power or "gate" winding and a control winding C1 and C2. Field excitation is controlled by operation of the magnetic amplifiers as described in the paragraphs that follow.

The single phase, 400 Hz, 120 Vac power applied to regulator terminals L1 and L2 magnetizes the magnetic amplifier core. During the time the core is being magnetized, it creates a back emf across the gate winding, limiting current flow. As magnetism of the core increases, the rate of change influx decreases, resulting in a decrease in back emf. This action continues until the core becomes fully magnetized (saturation). At this point no further change in flux density occurs. Resistance across the gate winding is then limited by the series resistance of the gate winding and field winding, and current flow is maximum. Control and regulation are accomplished by resetting the core of the magnetic amplifier at some point below saturation during the half-cycle the gate winding is not conducting. This is done by applying dc control current to magnetic amplifier control winding (C1-C2) and is referred to as magnetic reset or bias. Increasing the control current resets the magnetic amplifier core further below saturation. The further the core is reset below saturation the more back emf will be present across the gate winding. Thus, the less current will flow through the gate winding and series-connected exciter field. The magnetic amplifier reacts in an opposite manner when control current is decreased.

E. Stability

The voltage regulator includes a negative feedback system stability circuit designed to prevent oscillation (hunting) of the generator output voltage. The circuit consists of capacitors C2, C5, resistors R5, R6, R16 and a stability adjust potentiometer R7.

F. EMI Suppression

Filter RFL is included in the voltage regulator input power circuit to reduce conducted EMI to negligible levels.

SECTION 2 INSTALLATION

SAFETY SUMMARY

WARNING

To prevent injury to personnel or damage to equipment, this unit shall be installed only in accordance with the installation instructions and wiring diagrams contained in the instruction manual provided with this unit.

WARNING

When this unit is operating, 120 VAC and 208-240 VAC is present at the voltage regulator assembly terminal board and internal circuitry. To avoid accidental contact with lethal voltage, de-energize the generator set starting circuit while making electrical connections or repairs to this equipment.

CAUTION

Meggers and high potential test equipment should not be used. Incorrect use of such equipment could destroy the rectifiers, transistors and capacitors in the regulator.

LOCATION

The voltage regulator may be mounted in the generator terminal box or remotely mounted. The enclosure in which the regulator is to be mounted should be of sufficient size to permit flow of air about all sides of the regulator.

MOUNTING

Mounting holes are incorporated in the regulator base. The regulator can be mounted in any position without affecting its operating characteristics.

ELECTRICAL CONNECTIONS

The regulator must be connected to the generator system as instructed in the paragraphs that follow and as shown on the diagrams for the generator and control system. Number 14 gauge or larger wire should be used for all connections to the voltage regulator.

A. Regulator Input Power Terminals L1 and L2. The nominal voltage applied to the regulator input power stage (terminals L1 and L2) must be single phase, 400 hertz, 120 volt ac. The input power may be taken from any generator lines that provide the correct voltage (line-to-line or line-to-neutral). However, when single phase sensing is used, it is recommended that the input power be taken from a phase other than the one used for sensing. The phase relationship of this input in relation to other circuits is not important.

NOTE: When the generator output is different from the preceding value, a power transformer must be used to match the generator voltage to the required regulator input. If excessive voltage is applied to the regulator input (terminals L1 and L2), destruction of the rectifiers in the regulator could occur.

B. Fuse F1. The voltage regulator contains a 250 volt, 5 amp., ABC-5 type fuse located within a fuse holder that is mounted on the voltage regulator chassis as shown in Figure 5-2. Replacement fuse must be a normal break fuse of the same capacity. A time delay type fuse should not be used.

C. Grounding. The dc output circuit to the exciter field must not be grounded. Regulator chassis grounding can be accomplished by solidly mounting the voltage regulator onto a metal cubicle which in turn is grounded, or by connecting a ground wire from the regulator case to ground.

D. Regulator Sensing (Terminals E1 and E3). The voltage regulator is designed for single phase, 400-Hz, 208-240 VAC sensing. Follow the interconnection diagram provided with the generator set.

E. Sensing Transformer (T1). Verify that sensing transformer T1 located in the voltage regulator is connected as shown in Figure 5-2.

F. Voltage Regulator dc Output (Terminals F+ and F-). This circuit provides DC excitation to the exciter field. Observe correct polarity. F- connects to exciter field lead F1 (-) and F+ to exciter field lead F2 (+). In applications where field wires are longer than a foot or two, shielding by running the field lead through one-half inch conduit is recommended.

G. Externally Mounted Voltage Adjust Rheostat. Connect the voltage adjust rheostat as shown on the wiring diagram provided with the generator set and Figure 5-2. Make certain rheostat contains a jumper wire between its slider terminal 2 and the rheostat end terminal 1. When correctly connected, turning the rheostat clockwise increases generator voltage output.

H. Paralleling Terminals (CT1, CT2). On voltage regulators with paralleling, connect these terminals to the paralleling circuit as shown on the system drawing. If used for single unit operation, short terminal CT1 to CT2.

SECTION 3 CONTROLS ADJUSTMENT PROCEDURES AND VOLTAGE REGULATOR OPERATING PROCEDURES

SAFETY PRECAUTIONS

The precautions described in Section 2 must be followed when inspecting, making internal adjustments, or making repairs to this equipment.

VOLTAGE REGULATING SYSTEM CONTROLS

The voltage regulating system includes the external voltage adjust rheostat for adjustment of generator output voltage, a voltage range potentiometer R3 located on the circuit board that extends either the minimum voltage limit or maximum voltage of the voltage adjust circuit, and a stability control potentiometer R7 located on the circuit board that provides means of increasing or decreasing a stabilizing signal to attain optimum response and system stability. Adjustment procedures are as described in the paragraphs that follow.

A. Voltage Adjustment. This adjustment is made while the generator is running at rated frequency and while no-load is applied. Turning the externally mounted voltage adjust rheostat clockwise increases generator output voltage. When it is turned in a counter-clockwise direction, a decrease in generator output voltage should occur. Voltage is measured during the adjustment procedure by observing the generator voltmeter.

B. Voltage Range Adjustment. This adjustment extends either the minimum voltage limit or the maximum voltage limit of the external voltage adjust rheostat. It is normally factory set at about ½ its maximum travel. To limit maximum voltage adjust as follows:

NOTE: In applications that include overvoltage protection circuitry the maximum voltage setting should be lower than the overvoltage trip setting.

1. Operate generator at rated frequency with no-load applied. Turn the external voltage adjust to its maximum clockwise position.

NOTE: Turning R3 clockwise raises the maximum voltage while turning it counter-clockwise decreases the maximum voltage.

2. Measure generator voltage using the generator output voltage. If voltage is not the required maximum, turn potentiometer R3 in the appropriate direction until voltmeter indicates output voltage is the required maximum. This is the final adjustment of R3.
3. Turn external voltage adjust counter-clockwise to position where output voltage decreases to rated value.

C. Stability Adjustment R7. This control is located on the regulator printed circuit board. Adjust R7 only if during operation oscillating voltage or slow response occurs.

1. **Slow Response.** Turn R7 clockwise to position where response is satisfactory. Test with load applied and also with no-load applied. If oscillating voltage occurs turn R7 clockwise past the point where oscillation stops.
2. **Voltage Oscillating.** Turn R7 clockwise past the position where oscillations stop. Test no-load and with load applied.

NOTE: Slow response, loss of sensitivity and poor regulation could occur if R7 is turned too far counter-clockwise.

OPERATING PROCEDURES

The instructions that follow describe the procedures to be followed during initial operation and during subsequent operation of the unit. The preceding chapters as well as the following procedures should be reviewed and understood before system operation is attempted. The system operator should also locate all controls and adjustments pertinent to system operation before attempting to operate the equipment.

A. Initial Operation

1. Open output circuit breaker or contactor. Initial start-up should be made with no-load.
2. In applications where system includes overvoltage devices or a field circuit breaker, make certain the field circuit breaker and overvoltage circuit is not "tripped" open.

3. In applications where system includes both automatic voltage control and manual voltage control set mode selector switch to AUTO position for automatic voltage regulation.
 4. Start the generator set and bring up to rated speed.
 5. Verify generator voltage. Any of the following conditions may occur:
 - a) Overvoltage — If this condition occurs adjust the auto voltage adjust rheostat as described in paragraph A, Voltage Adjustment. If condition persists, stop the prime mover and determine cause of malfunctions.
 - b) Undervoltage — If conditions occurs adjust the auto voltage adjust rheostat as described in paragraph A, Voltage Adjustment. If conditions persists, stop the prime mover and determine cause of malfunction.
 - c) No voltage build-up — If this condition exists and an auto/manual switch is incorporated, stop the prime mover, set auto/manual switch to manual position, start generator set and see if voltage builds up.
- NOTE: Alternative methods of testing to isolate faulty operation and a troubleshooting chart are given in Chapter 4.**
- d) Oscillating Voltage (Hunting) - If this condition exists adjust stability control as described in paragraph C, Stability Adjustment R7. If problem persists, refer to troubleshooting procedures. Voltage hunting can be caused by an unstable prime mover.
 - e) Voltage Unstable or Slow Response - Adjust Stability Adjust R7 as described in paragraph C.
6. Turn auto voltage adjust rheostat to obtain desired voltage.
 7. The voltage regulator is now ready for load test.
 8. Close output circuit breaker and apply load to generator.
 9. Verify that the voltage regulation is within $\pm 1\%$. If it is not within these limits, refer to troubleshooting procedures.
 10. Alternately remove and apply load to determine whether the generator voltage is stable and response is satisfactory.
 11. If the generator voltage becomes unstable or response is slow, adjust stability adjust R7.
 - a) Instability may occur when the no-load field requirements of the exciter are near the minimum working voltage of the regulator.
 - b) On engine driven or dc motor driven generator sets, unstable speed governors are frequently the cause of generator voltage instability. If a stability problem still exists after performing the procedure as described in paragraph C, check the governor.
 12. After satisfactory initial operation has been determined, remove load, open output circuit breaker and stop generator set.

B. General Procedure for Subsequent Operation of Unit

1. Verify that overvoltage circuitry and field circuit breakers, when included in generating system, are not tripped open.
2. In applications where generating system includes both automatic voltage control and manual voltage control, set the mode selector switch to AUTO position.
3. Start generator set and bring up to rated speed.
4. Verify generator voltage. If voltage is not correct adjust the voltage control rheostat as described in Voltage Regulating Controls, paragraph A in this section.
5. Close output circuit breaker or contactor and apply load.
6. During operation periodically check system meters to ensure that generator set is operating satisfactorily.
7. Before stopping generator set, remove load and open output circuit breaker.

SECTION 4 MAINTENANCE

SAFETY SUMMARY

The precautions described in Section 2 must be followed when inspecting, testing or making repairs to this equipment.

PREVENTIVE MAINTENANCE INSPECTION

Semi-annual inspection should be made on this unit to insure that it is kept free of dirt and moisture. Wiring should be inspected for satisfactory condition (absence of frayed or broken insulation) and all connections should be inspected and tightened.

TROUBLESHOOTING PROCEDURES

Troubleshooting is the process of recognizing malfunctions of the system, intelligently analyzing the malfunction, and making the necessary corrections to place the unit back into proper operation. The more common generator system malfunctions and the appropriate repair procedures are listed in the following Troubleshooting Chart. Following the chart are methods of isolating system malfunctions and instructions for voltage regulator tests.

Table 4-1 Troubleshooting Chart

Symptom	Probable Cause	Probable Remedy
Voltage does not build-up to rated value.	Voltage adjust rheostat not set correctly.	Adjust rheostat.
	Voltage regulator fuse (F1) blown.	Install new fuse.
	No field flashing voltage.	Verify flashing assembly output. Refer to wiring diagrams provided with the generator set.
	Circuit breaker in incoming power to voltage regulator open.	Ascertain cause of circuit breaker trip. Correct abnormal condition and then reset the circuit breaker.
	Improper voltage or loose connections to regulator power terminals L1 and L2.	Check connections. Check input voltage. Should be 120 VAC, 400 HZ.
	Generator output heavily loaded or shorted.	Remove short or excessive load.

Table 4-1 Troubleshooting Chart (cont.)

Symptom	Probable Cause	Probable Remedy
Voltage does not build-up to rated value (cont).	<p>Regulator rectifier assembly BR1 or BR2 open or shorted.</p> <p>Magnetic amplifier MA-1 or MA-2 open.</p> <p>Loose connections to exciter field (terminals F+, F-)</p> <p>Defective exciter or generator.</p>	<p>Test rectifiers.</p> <p>Check continuity of magnetic amplifier windings. Replace amplifiers if windings are open.</p> <p>Check connections.</p> <p>See generator manual.</p>
Low Voltage	<p>Open rectifier in assembly BR1 or BR2.</p> <p>Preamplifier (PC board) failure.</p> <p>Voltage adjust not properly adjusted.</p> <p>Voltage range adjust R3 requires adjustment.</p>	<p>Test. Replace if any of its rectifiers are defective.</p> <p>Replace PC board.</p> <p>Adjust rheostat.</p> <p>Adjust for minimum voltage while external voltage adjust is turned to complete counter-clockwise position.</p>
High Voltage.	<p>Voltage adjust rheostat not properly adjusted.</p> <p>Voltage range adjust R3 requires adjustment.</p>	<p>Adjust rheostat.</p> <p>Adjust for maximum voltage while voltage adjust is turned to complete clockwise position.</p>

Table 4-1 Troubleshooting Chart (cont.)

Symptom	Probable Cause	Probable Remedy
High Voltage (cont.)	<p>Preamplifier (PC board) defective.</p> <p>Magnetic amplifier MA-1 MA-2 shorted.</p> <p>Sensing open or wrong sensing taps.</p> <p>Excessive voltage applied to regulator power (terminals L1 and L2).</p>	<p>Replace PC board.</p> <p>Check for shorts.</p> <p>Check wiring. If correct, check for open sensing transformer T1.</p> <p>Check wiring. Power should be 120 VAC, $\pm 10\%$, 400 HZ.</p>
Voltage unstable.	Stability adjust potentiometer R7 not properly set. (Stability insufficient).	Adjust R7 as described in Chapter 3.
Slow response.	<p>Excessive load.</p> <p>Stability adjust R7 not properly set.</p>	<p>Remove excessive load.</p> <p>Adjust R7 as described in Chapter 3.</p>
Poor regulation.	<p>Excessive load.</p> <p>Stability adjust R7 not properly set.</p>	<p>Remove excessive load.</p> <p>Adjust R7 as described in Chapter 3.</p>

Isolating System Malfunction to Faulty Operation of the Voltage Regulator or the Generator by Measuring Field Excitation

Measurement of exciter field current and exciter field voltage while monitoring generator output voltage will provide an indication as to whether faulty system operation is due to voltage regulator failure or generator or exciter problems. The measurements should be compared with data taken during testing of the unit at the factory. Slight deviations may exist due to differences in operating 5 amp dc ammeter and a 100 volt dc voltmeter as shown in Figure 4.1. Abnormal conditions and the probable failure are as follows:

A. Both Excitation and Generator Output Voltage Lower than Normal During No-Load Operation or with Load Applied. If this condition occurs the problem is most likely faulty operation of the voltage regulator.

B. Generator Voltage Lower than Normal and Excitation Higher than Normal. Make certain problem is not generator overload. If this condition persists, the problem is most likely in the exciter winding, exciter diodes or generator field winding. Test windings for open or shorted turns and test diodes for open or short circuit.

C. Generator Voltage High and Excitation High. If this condition occurs, the problem could be due to voltage regulator failure or an open circuit in either the sensing circuit or voltage adjust. Inspect wiring to the voltage regulator and inspect the external voltage adjust rheostat before assuming voltage regulator has failed.

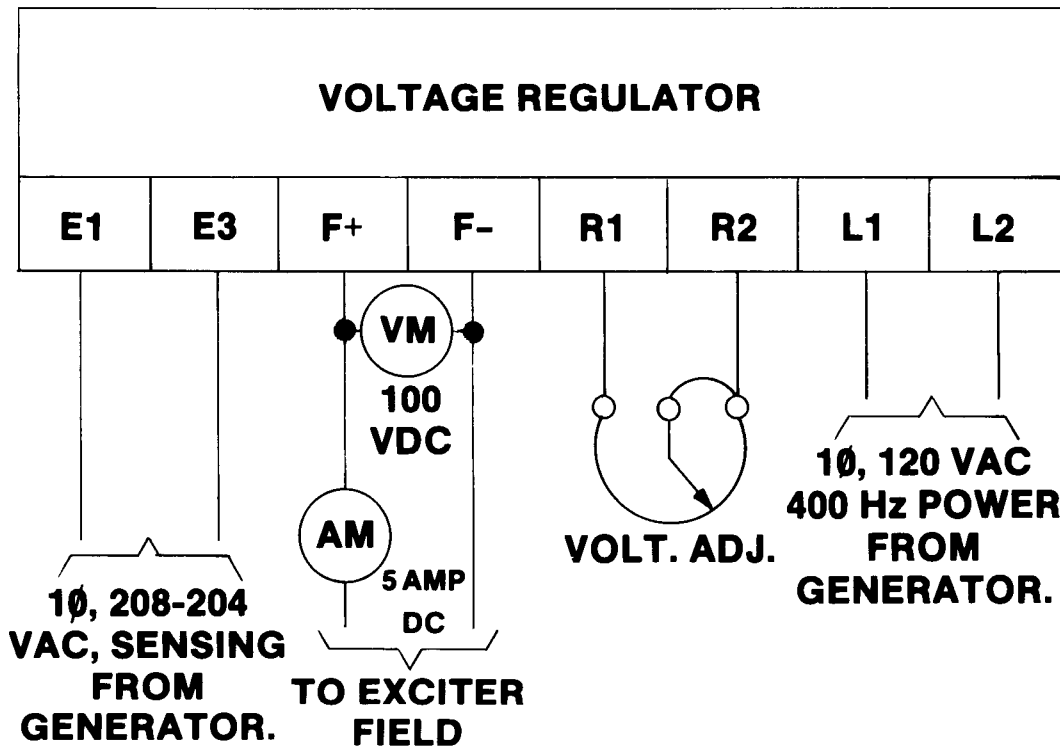

NOTE: Dc Ammeter installed in line from exciter. Dc voltmeter across F+, F-. All other interconnection to voltage regulator must be as shown on wiring diagram provided with the generator set.

Figure 4-1 Field Voltmeter and Ammeter Installation Drawing

System Malfunction Trouble Isolation by Using Manual Voltage Control to Provide Field Excitation

Generator sets equipped with both automatic and manual voltage control can be tested in the manual voltage control mode to determine whether faulty system operation is due to a generator malfunction or faulty voltage regulator operation. In applications where generating system does not include the manual voltage control circuit, a manual voltage control circuit can be temporarily constructed to test the system by using batteries, a 100 ohm or larger rheostat, a 10 volt dc voltmeter and 5 ampere dc ammeter connected as shown in Figure 4-2. Several batteries may be connected in series to provide the required excitation voltage. Test as follows:

CAUTION

Batteries must not be grounded as the exciter field and voltage regulator output circuit must not be grounded.

1. Stop generator set.
2. Connect batteries and test instruments as shown in Figure 4-2. Make certain none of the existing wires are removed from regulator terminals F+ and F-.
3. Remove wire(s) from regulator terminal L1. If more than one wire was run to terminal L1, connect ends of wires together. Insulate ends of wires to prevent grounding during this test.
4. Remove wire(s) from regulator terminal L2. If more than one wire was run to terminal L2, connect ends of wires together. Insulate ends of wires to prevent accidental grounding during this test.

NOTE: Abnormal conditions that could occur are listed in Step 9.

5. Start generator set and adjust generator output voltage to rated using the test rheostat. Measure excitation.
6. If no-load voltage and excitation is normal, close output circuit breaker and apply about 1/4 of rated load.
7. Adjust generator output voltage using test rheostat and measure excitation.
8. Increase load in increments of about 1/4 of full load and repeat Step 7 at each step change in load.
9. The following conditions can occur during test using manual voltage control to supply field excitation.

a) Rated output voltage and excitation during manual voltage control operation but abnormal when voltage regulator was operating. This condition indicates a voltage regulator failure.

b) Low output voltage and high excitation during both manual voltage control operation and automatic voltage control operation. This condition indicates a failure of the exciter windings, generator field windings or the exciter diodes.

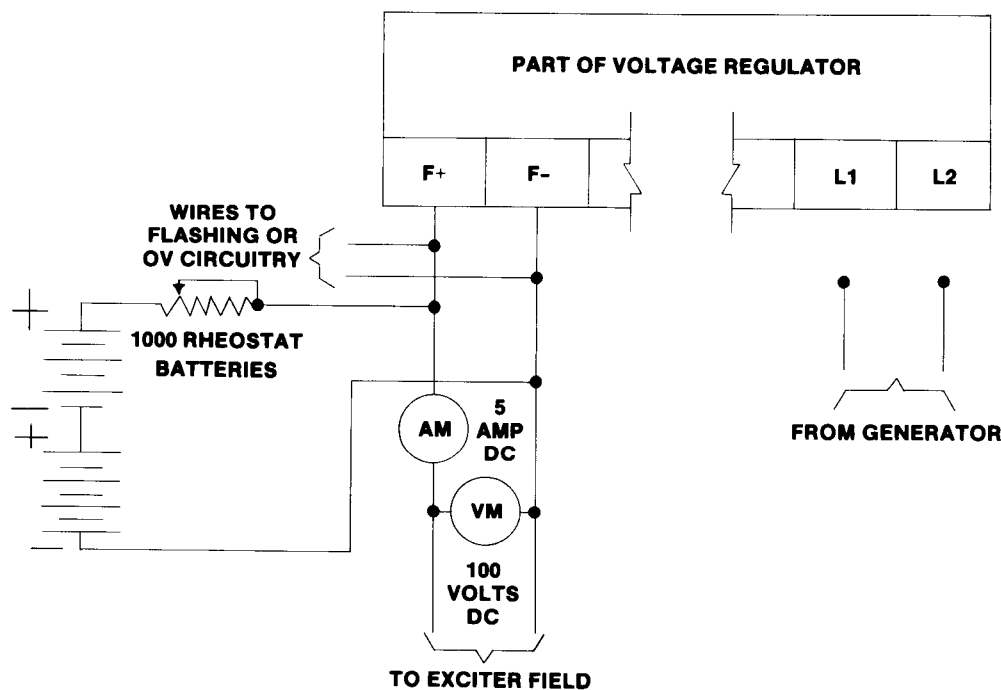

Figure 4-2 Typical Connection Diagram; Battery Powered Excitation Circuit for Trouble Isolation Test

10. Remove load in step changes of about 1/4 of rated load, decreasing generator voltage to rated using the test rheostat at each step change in load.
11. Shutdown generator set and open output circuit breaker.
12. Remove batteries and test instruments and reconnect wires onto regulator terminals.

VOLTAGE REGULATOR TEST

This test is made with the generator set stopped and the voltage regulator completely disconnected from the generator. It requires a single phase, 208/240 VAC, 400-hertz power source, a single phase, 120 VAC power source, a variac (variable transformer), a 25 ohm, 100 watt resistor, a 100 vdc voltmeter and a 5 ampere dc ammeter connected as illustrated in Figure 4-3. The conditions listed below occur if the voltage regulator is operating properly.

A. Turning the variac in the direction that decreases the voltage at terminals E1 and E3 should result in an increase in output measured at terminals F+ and F-. The opposite condition should occur when the rheostat is turned in a counter-clockwise direction.

B. Turning the voltage adjust rheostat clockwise should increase output measured at F+ and F-. The opposite condition should occur when the rheostat is turned in a counter-clockwise direction.

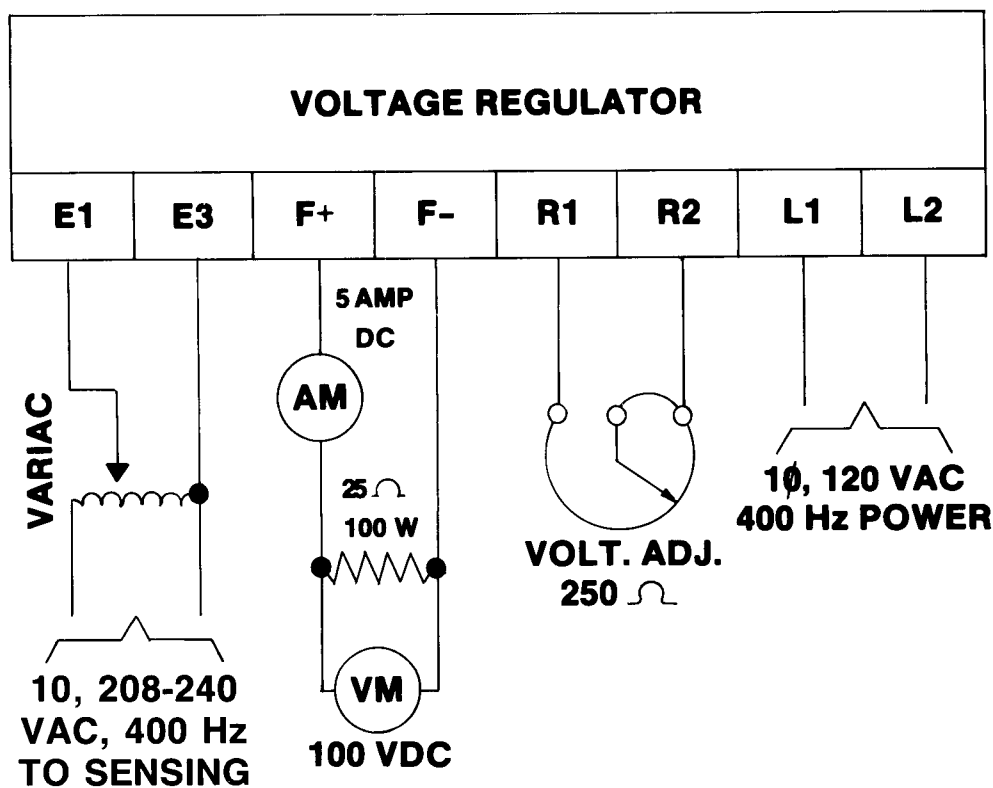

Figure 4-3 Voltage Regulator Test Connection Diagram

VOLTAGE REGULATOR COMPONENT TEST PROCEDURES

General procedures for testing various parts are described in the paragraphs that follow.

A. Magnetic Amplifier Test. Typical defects are open or shorted windings. Open windings can be determined by disconnecting the magnetic amplifier from the circuit and then testing winding resistance. Shorted windings generally can be detected by comparing the winding resistance with the winding resistance of an identical magnetic amplifier known to be in good condition. Because the magnetic amplifier gate winding is in series with the field, shorted turns will result in higher than normal current flow while an open winding will result in low or zero output.

B. Rheostats and Resistor Test. Check resistance with an ohmmeter. Rheostats and adjustable resistors should be checked over their full range. Care should be taken to avoid damage to the fine wire when setting adjustment bands on adjustable resistors.

C. Surge Suppressor Test. Non-polarized surge suppressors should have a very high resistance in both forward and reverse directions. Polarized surge suppressors will have a very high resistance in the reverse direction and should have a resistance of 100 ohms or more in the forward direction.

D. Rectifiers (Diodes). Individual diodes can be tested for open and short circuit by measuring forward and reverse resistances. A diode should have a relatively low resistance in the direction of normal current flow and high resistance in the opposite direction.

E. Power Transformer Test. Power transformers including the sensing transformer can be tested by measuring the secondary voltage while rated voltage is applied to the primary winding.

F. Silicon Transistor Test. Transistors can be tested with a three-volt test lamp comprised of batteries and a light bulb. The transistor should give the light indication given in Table 4-2.

G. Zener Diode Test. A zener diode may be checked with an ohmmeter in much the same manner as a silicon diode is checked, or it can be tested using a dc power supply and the test instrumentation illustrated in Figure 4-4. Using test instrumentation connected as shown in Figure 4-4, voltage across the zener diode should stay relatively constant as the dc voltage is increased. Current through the zener diode will increase rapidly. Care should be taken not to exceed the current and voltage rating of the zener diode.

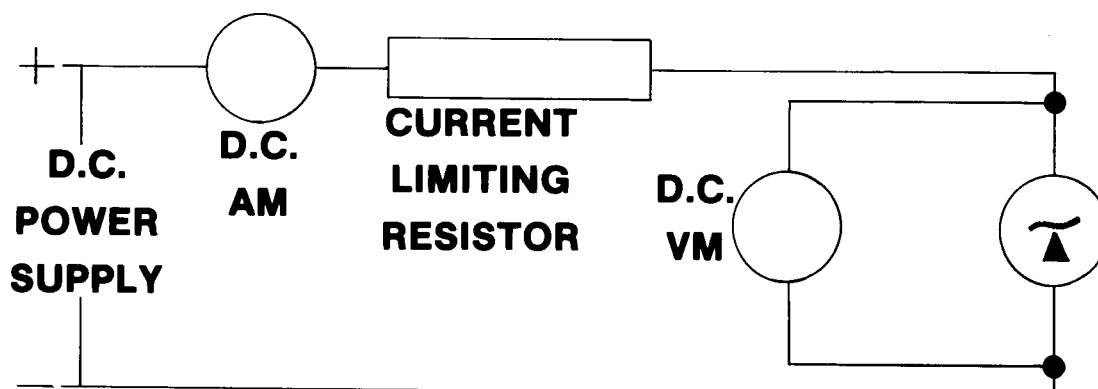

Figure 4-4 Zener Diode Test

TABLE 1 TRANSISTOR TEST CHART

TYPE TRANSISTOR	TEST LAMP NEGATIVE LEAD CONNECTED TO-	TEST LAMP POSITIVE LEAD CONNECTED TO-	LIGHT INDICATION
NPN	BASE BASE	EMITTER COLLECTOR	NO LIGHT NO LIGHT
	EMITTER COLLECTOR	BASE BASE	LIGHT LIGHT
PNP	BASE BASE	EMITTER COLLECTOR	LIGHT LIGHT
	EMITTER COLLECTOR	BASE BASE	NO LIGHT NO LIGHT

SECTION 5 PARTS LIST AND DRAWINGS

GENERAL

Voltage regulator parts list and drawings are contained on the pages that follow. Because of the difficulty of making repairs to conformal-coated circuit boards, replacement of board rather than repair is recommended.

Table 5-1 Static Exciter Regulator Parts List

KEY NO.	DESCRIPTION	PART NUMBER	NO. REQ'D
AMP1	Printed Circuit Board	841-02053-73	1
MA1, MA2	Magnetic Amplifier	857-42411-90	2
F1	Fuse Holder	516-30001-00	1
	Fuse, 5 amp. 250 volt (#ABC-5)	515-01205-31	1
T1	Transformer, Sensing, 208-240V	855-62810-01	1
T3	Transformer, Power	855-52810-00	1
T4	Transformer, Paralleling	855-11610-01	1
L1	Choke, E187	859-52010-00	1
TB1	Terminal Strip	531-30311-12	1
BR1	Bridge Rectifier Assembly	851-31616-10	2
	RFI Filter Assembly	514-00404-97	1
VAR	Voltage Adjust Rheostat		
	Use either of the following as listed on the generator set.		
	UL Listed 250 Ohm, 25 Watt Rheostat or	867-32575-23	1
	250 Ohm, 2 Watt, Potentiometer	867-32522-80	1

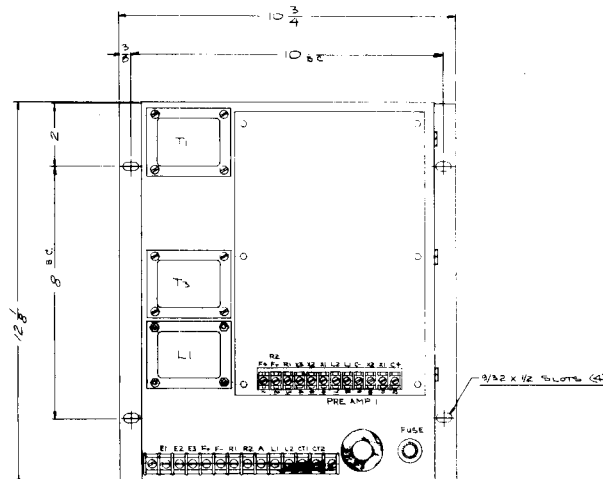

Fig. 5-1 Regulator Outline Drawing

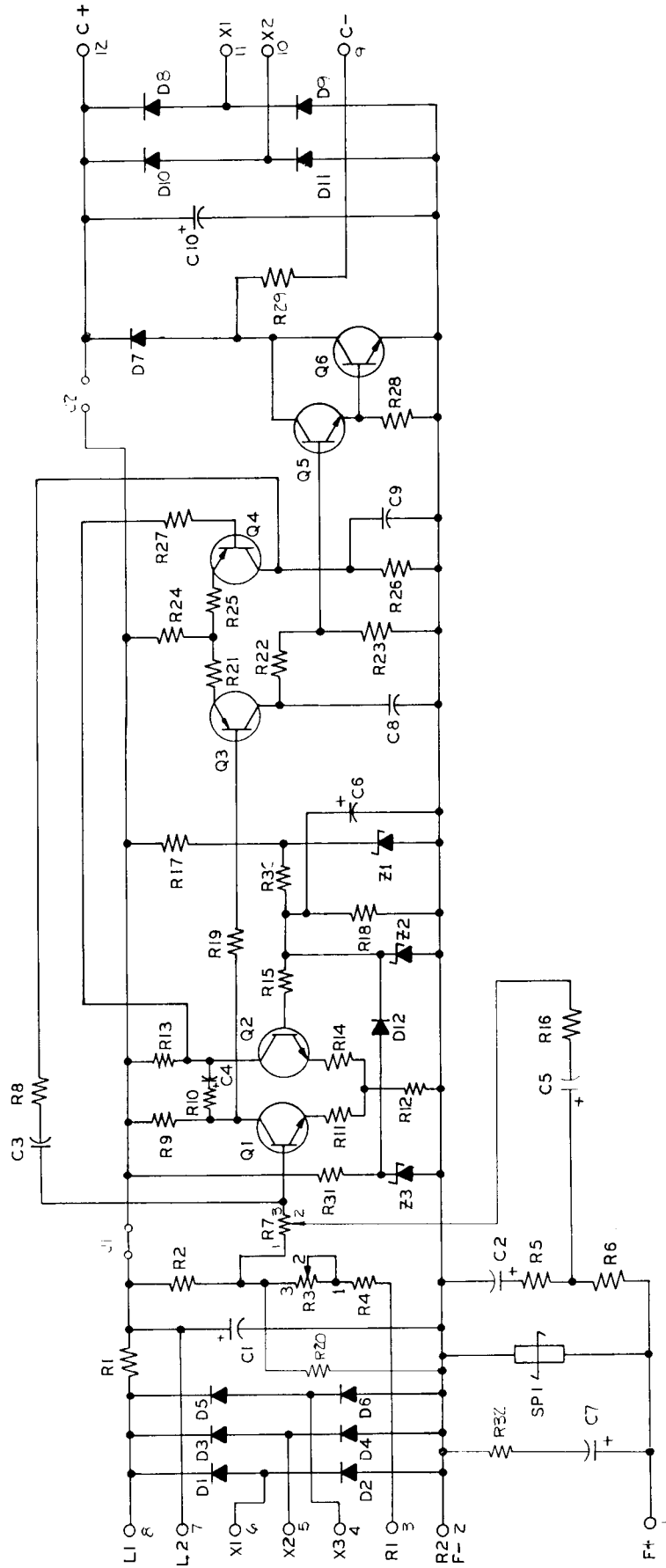

Fig. 5-3 Circuit Board Schematic

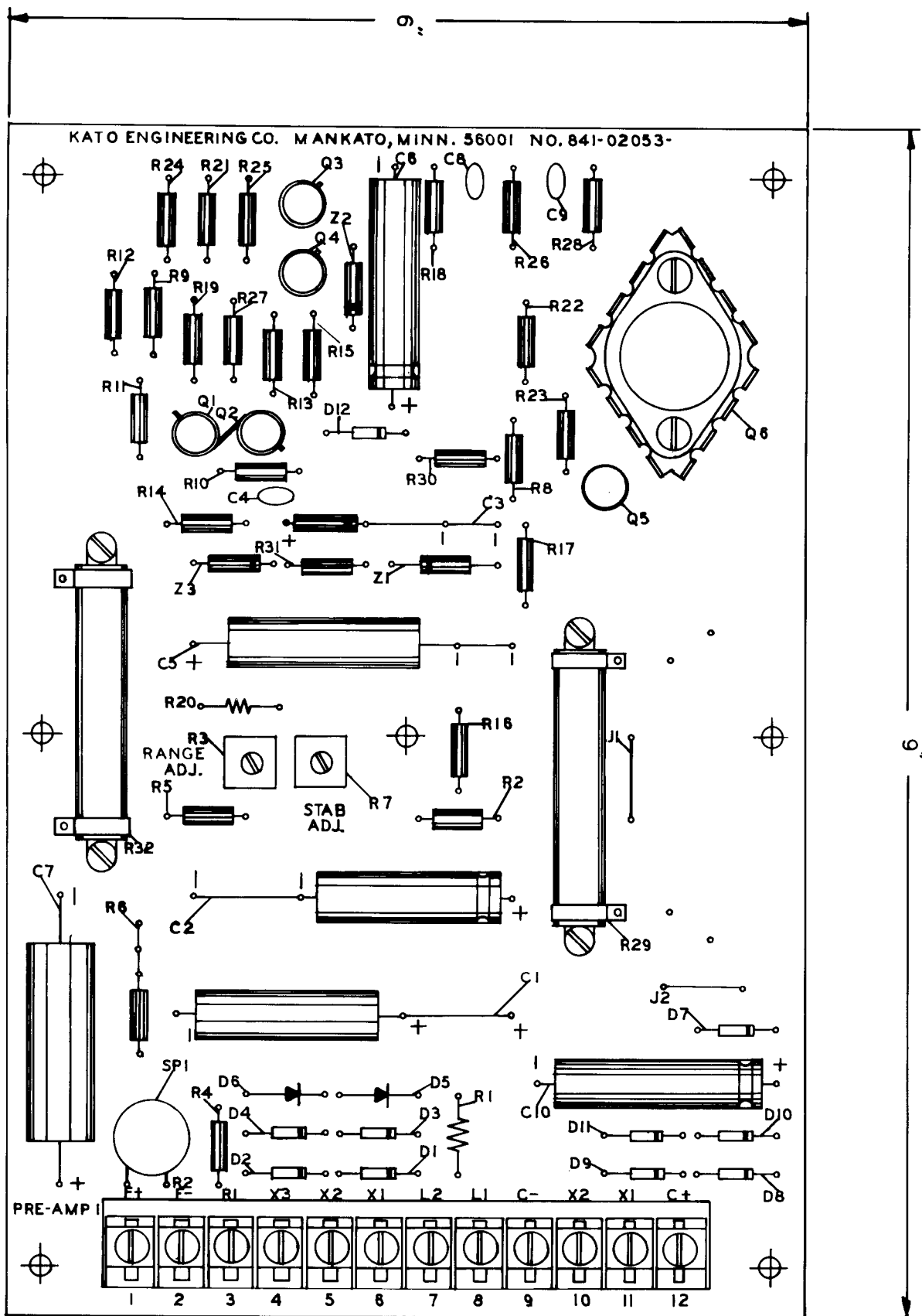

Fig. 5-4 Circuit Board Outline Drawing

P.O. Box 47 / Mankato, Minnesota 56001 / (507) 625-4011 TLX: 29-0786 / PN: 351-01004-00

KATO ENGINEERING 
RELIANCE ELECTRIC