

Instruction Manual

Installation • Operation • Maintenance



KCR 360 Voltage Regulator



Kato Engineering Inc.
P.O. Box 8447
Mankato, MN USA
56002-8447
Tel: 507-625-4011
Fax: 507-345-2798
Email: katoengineering@lsusa.com
www.kato-eng.com

Note: Because of rapid changes in designs and processes and the variability of Kato Engineering's products, information in this manual must not be regarded as binding and is subject to change without notice.

Table of Contents

Introduction.....	4
Foreword.....	4
Safety instructions.....	4
Ratings/description.....	4
Features and options, accessories, specifications.....	4
Overview.....	4
Standard features and options.....	5
Accessories.....	6
Specifications.....	8
Operating principles.....	11
Installation.....	22
Mounting.....	22
Interconnection.....	22
Sensing.....	22
Input power.....	24
Grounding.....	24
Output power.....	24
External voltage adjust rheostat.....	24
Connection to terminals CT1 and CT2.....	24
Underfrequency limit.....	25
Voltage regulator fuse.....	25
Accessory items.....	26
Operation.....	27
Adjustments.....	27
Field flashing.....	28
Single unit initial operation.....	29
Parallel operation.....	31
Maintenance.....	34
Preventive maintenance.....	34
Corrective maintenance.....	34
Operational test.....	35
Troubleshooting.....	35

Figures and Tables

Figure 1: Underfrequency performance.....	9
Figure 2: Outline drawing.....	10
Figure 3: KCR 360 schematic.....	12
Figure 4: Underfrequency limit UFL electrical schematic.....	13
Figure 5: Parallel operation voltage droop CTs interconnection.....	15
Figure 6: Crosscurrent CTs interconnection.....	17
Figure 7: Change in SCR phase angle.....	19
Figure 8: Typical KCR 360 voltage regulator interconnection.....	23
Figure 9: Operational test connection diagram.....	35
Table 1: Standard KCR 360 regulators.....	7
Table 2: Voltage across under frequency limit terminals TP1-TP2, 60 Hz..	28
Table 3: Voltage across under frequency limit terminals TP1-TP2, 50 Hz..	28
Table 4: Replacement parts list.....	34
Table 5: Troubleshooting.....	36

Introduction

Foreword

This manual contains instructions for installing, operating and maintaining Kato Engineering KCR 360 voltage regulators.

Please read this manual in its entirety before installing, operating, and servicing your regulator.

Safety instructions

In order to prevent injury or equipment damage, everyone involved in installation, operating and maintenance of the equipment described in this manual must be qualified and informed of the current safety standards that govern his or her work.

While “common-sense” prevention of injury or equipment damage cannot be completely defined by any manual (nor built into any piece of equipment), the following paragraphs define warnings, cautions, and notes as they are used in this manual:

Warning: Warnings identify an installation, operating or maintenance procedure, practice, condition, or statement that, if not strictly followed, could result in death or serious injury to personnel.

Caution: Cautions identify an installation, operating or maintenance procedure, practice, condition, or statement that, if not strictly followed, could result in destruction of or damage to equipment or serious impairment of system operation.

Note: Notes highlight an installation, operating or maintenance procedure, condition, or statement and are essential or helpful but are not of known hazardous nature as indicated by warnings and cautions.

Features and options, accessories, specifications

Overview

The KCR 360 voltage regulator is designed for operation with brushless synchronous generators. The voltage regulator controls generator voltage by regulating the amount of current it supplies the exciter field. The maximum continuous output rating of this regulator is 65 Vdc, 5 A, with one minute field forcing capacity of 90 Vdc, 7 A. It is designed primarily for 50/60 Hz or 400 Hz generators up to 400 kW that have exciter field resistance of not less than 10 Ω or more than 400 Ω .

The KCR 360 voltage regulator consists of transformers, transistors, silicon diodes, silicon controlled rectifiers (SCRs), integrated circuits, resistors, and capacitors. The regulators are relatively unaffected by humidity, temperature, vibration, or shock and are not subject to wear from moving parts. Solid-state field flashing components rather than relays are used in the field flashing and underfrequency circuits, eliminating the possibility of contact arcing or contact failure.

Standard features and options

The KCR 360 voltage regulator has silicon controlled rectifiers (SCRs) in the output stage. Electromagnetic interference (EMI) filtering in the output circuit reduces the conducted interference generated by the SCR power stage to negligible levels.

KCR 360 voltage regulators, except when the flat regulation option or volts-per-hertz sensing option is specified, include a very precise solid-state underfrequency limit. The underfrequency limit protects the generator and exciter during underspeed operation. At speed below the predetermined frequency where limiting begins, the decrease in voltage is proportional to the decrease in frequency.

The KCR 360 voltage regulators also includes solid-state field flashing and parallel operation components. The paralleling input is isolated for use during parallel generator operation in either the voltage droop mode or cross-current compensation mode.

Options available on the KCR 360 voltage regulator are listed as follows. These features required must be indicated on the purchase order when ordering the voltage regulator.

- Special UFL underfrequency operational threshold

For use with turbo charged engine driven generator sets.
Typically 48 Hz for 50 Hz operation; 58 Hz for 60 Hz operation.

For different setting or application state required operational threshold in purchase order.

- Volts-per-hertz sensing
- Flat regulation: For motor-generator set application where voltage must remain constant and for variable frequency/constant voltage application.
- Special voltage or frequency sensing: For applications where sensing voltage or frequency requirements differ from those listed in specifications.

Accessories

Power isolation transformers and voltage matching power

transformer: Kato Engineering power isolation transformers are designed specifically for voltage regulators that have silicon-controlled rectifiers in the output stage. They are available with 120 Vac primary windings and 120 Vac secondary windings and are for power isolation. Voltage matching power transformers that also provide power isolation are available for applications when 120 Vac cannot be obtained from the generating system. Voltage matching power transformers are also available for use in applications where it is necessary to reduce the generator output voltage to the level required by the voltage regulator sensing transformer. As an example, for use with a three or four-wire 4160 Vac generator, a transformer is required that has a 4160 Vac primary and either a 600, 480, 416, 240, 208, or 120 Vac secondary.

Paralleling current transformers: A complete line of current transformers designed specifically for parallel generator operation is available. When consulting the factory be sure to give the generator's rated voltage, kVA, and full load line current.

Field circuit breaker: The field circuit breaker opens power to the voltage regulator (terminal P1 or P2). The circuit may be either the type that trips when dc excitation is excessive or the type that measures generator line current through a current transformer and trips when line current is excessive. The field circuit breaker can be manually tripped during underspeed operation or emergency voltage shutdown.

Auto/manual voltage control: Kato auto/manual voltage control modules are for use with regulators used in brushless generator applications. The module includes a full wave rectifier, a variable transformer (variac) for manual voltage control and a three-position switch. The switch allows the generator to be controlled either automatically by that voltage regulator or manually. The OFF position provides voltage shutdown by de-energizing both the voltage regulator and the manual voltage control rectifier.

Engine idle switch (voltage shutdown switch): This switch disconnects power to the voltage regulator (terminal P1 or P2). The switch should be included in engine generator set systems when the voltage regulator does not have underfrequency limit circuitry or when the system does not include a field circuit breaker or auto/manual voltage control option.

Standard KCR 360 voltage regulators are shown in Table 1. To use this table to identify the KCR 360 model you have received, find the part number of your regulator on the part list located near the back of your instruction book. The table shows the operating characteristics of each regulator. Be sure to use this information when contacting Kato Engineering for regulator repair or replacement.

Regulator number	Sensing	Sensing response*	Power	Notes
821-36000-00	50/60 Hz	Flat	50/60 Hz	
821-36000-92	50/60 Hz	Flat	50/60 Hz	Note 4
821-36000-99	50/60 Hz	Flat	50/60 Hz	Note 1
821-36001-00	50/60 Hz	55 Hz, UFL	50/60 Hz	
821-36001-01	50/60 Hz	55 Hz, UFL	50/60 Hz	Note 2
821-36001-02	50/60 Hz	58 Hz, UFL	50/60 Hz	Note 3
821-36001-05	50/60 Hz	59.5 Hz, UFL	50/60 Hz	
821-36001-09	50/60 Hz	57 Hz, UFL	50/60 Hz	
821-36001-11	50/60 Hz	58 Hz, UFL	50/60 Hz	Note 2
821-36001-92	50/60 Hz	55 Hz, UFL	50/60 Hz	Note 4
821-36001-98	50/60 Hz	55 Hz, UFL	50/60 Hz	Note 5
821-36001-99	50/60 Hz	55 Hz, UFL	50/60 Hz	Note 1
821-36002-00	50/60 Hz	Volts/Hz	50/60 Hz	
821-36030-00	50/60 Hz	Flat	400 Hz	
821-36031-00	50/60 Hz	55 Hz, UFL	400 Hz	
821-36032-00	50/60 Hz	Volts/Hz	400 Hz	
821-36200-00	400 Hz	Flat	50/60 Hz	
821-36200-92	400 Hz	Flat	50/60 Hz	Note 4
821-36201-00	400 Hz	365 Hz, UFL	50/60 Hz	
821-36201-02	400 Hz	385 Hz, UFL	50/60 Hz	Note 3
821-36201-92	400 Hz	365 Hz, UFL	50/60 Hz	Note 4
821-36202-00	400 Hz	Volts/Hz	50/60 Hz	
821-36230-00	400 Hz	Flat	400 Hz	
821-36231-00	400 Hz	385 Hz, UFL	400 Hz	
821-36231-02	400 Hz	385 Hz, UFL	400 Hz	Note 3
821-36232-00	400 Hz	Volts/Hz	400 Hz	
821-36800-00	24 Vdc	Flat	50/60 Hz	
821-36830-00	24 Vdc	Flat	400 Hz	

Notes:

1. Special component values for stability on some applications.
2. Fuse removed to meet U.S. National Fire Protection Codes for operation in Class I Group D Division 2 Hazardous Environments. Regulator protection must be provided by an external hermetically sealed magnetic circuit breaker.
3. UFL set at 58 Hz or 385 Hz for application on turbocharge engines.
4. Special component values for slow generator build up on some applications.
5. Underfrequency limit modified to withstand 300% overspeed.

* Where UFL values are listed as 55 or 58 Hz, operation is 60 Hz. Review the manual for modification to 50 Hz operation

Table 1: Standard KCR 360 regulators

Specifications

Sensing: Sensing is single phase and measures average voltage.

Refer to the options in this section when the voltage regulator includes special sensing option. Sensing requirements for standard 50/60 Hz and 400 Hz KCR 360 voltage regulators are as follows:

- *Frequency:* 50/60 Hz or 400 Hz
- *ac voltage:* 100 to 139, 200 to 228, 216 to 265, 375 to 458, 432 to 528, 540 to 600
- *Voltage adjustment range:* 10%
- *Voltage adjust rheostat:* External, 250 Ω , 2 W minimum
- *Sensing transformers taps marked:* 120, 208, 240, 416, 480, and 600
- *Burden:* 6 VA maximum

Note: If the correct voltage is not available or if the field is grounded, a matching isolation transformer must be used.

Note: Minimum generator residual voltage for automatic field flashing is 6 Vac at terminals P1 and P2.

Input power:

- *Voltage:* 100 to 139 Vac, single phase
- *Frequency:* 50/60 Hz or 400 Hz
- *Burden:* 600 Va maximum

Power output with 120 Vac input power:

- *Voltage:* 65 Vdc, maximum continuous; 90 Vdc, 1-minute forcing
- *Current:* 5 A, maximum continuous; 7 A, 1-minute field forcing
- *Field resistance:* 10 Ω minimum, 400 Ω maximum
- *Fused:* 8 A, ABC type fuse

Paralleling: 1 A for 6% droop, maximum burden 5 VA. Isolated for paralleling generator operation in either the reactive voltage droop mode or cross-current compensation mode. Set for 4% droop prior to shipment from factory.

Underfrequency protection underfrequency limit: Except where an optional feature is included, the underfrequency limit (UFL) circuit will provide underfrequency protection by reducing voltage proportional to frequency (see Figure 1). The frequency where limiting starts is as follows:

- 55 Hz for 60 Hz systems
- 45 Hz for 50 Hz systems
- 365 Hz for 400 Hz systems

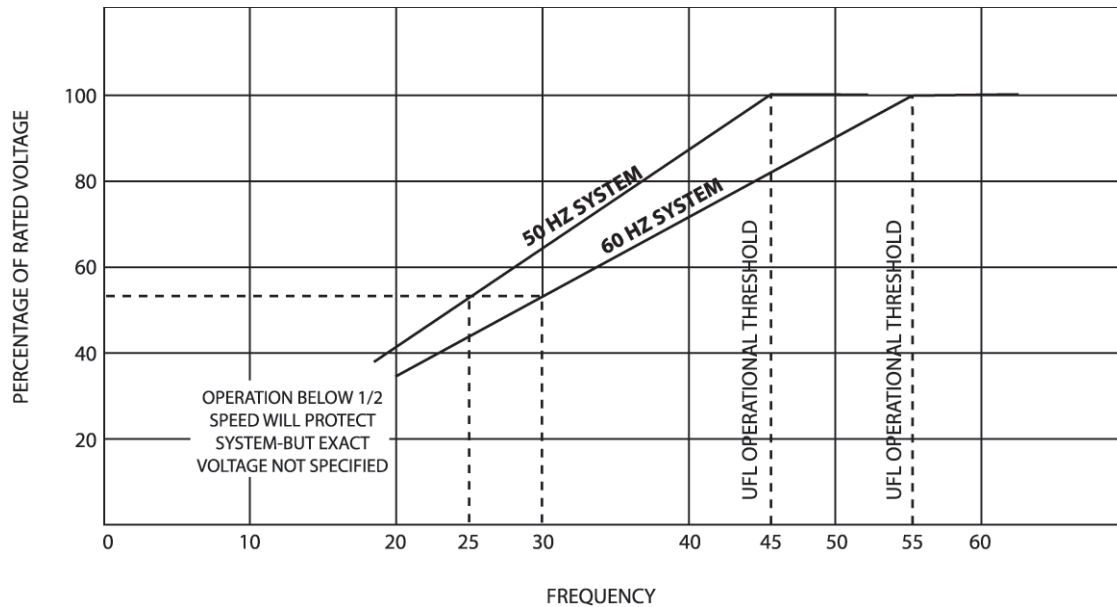

Figure 1: Underfrequency performance

Regulator accuracy: 1% over full range of generator loading and at generator speed deviation up to 5% from rated.

Regulator response: Less than 17 milliseconds

Thermal stability: Less than 1% for 40° C change in ambient temperature.

Operating temperature: -40° C to 60° C

Storage temperature: -60° C to 85° C

Power dissipation: Less than 35 W at maximum continuous rating during single generator operation; less than 40 W at maximum continuous rating parallel generator operation.

Electromagnetic interference suppression: KCR 360 voltage regulators include conducted electromagnetic interference filters in the voltage regulator input power circuit.

Shock: Tested to withstand up to 20 gs in each axis.

Vibration: Tested to withstand 1.2 gs from 6 to 26 Hz; 0.32 inch amplitude from 26 to 52 Hz; 5 gs from 53 to 150 Hz.

Construction: Steel chassis with welded seams, zinc plated per specification QQ-2-325, Type II, Class 2; circuit board is silicon resin conformal coated.

Dimensions: 7.5 inches (191 millimeters) x 7.25 inches (184 millimeters) x 3 29/32 inches (100 millimeters). See Figure 2.

Weight: 6.2 lbs. (2.81 kilograms) net. 7 lbs (3.18 kilograms) shipping weight

Mounting: May be mounted in any position providing sufficient space around the unit for satisfactory cooling. Be sure shock and vibration do not exceed regulator specifications.

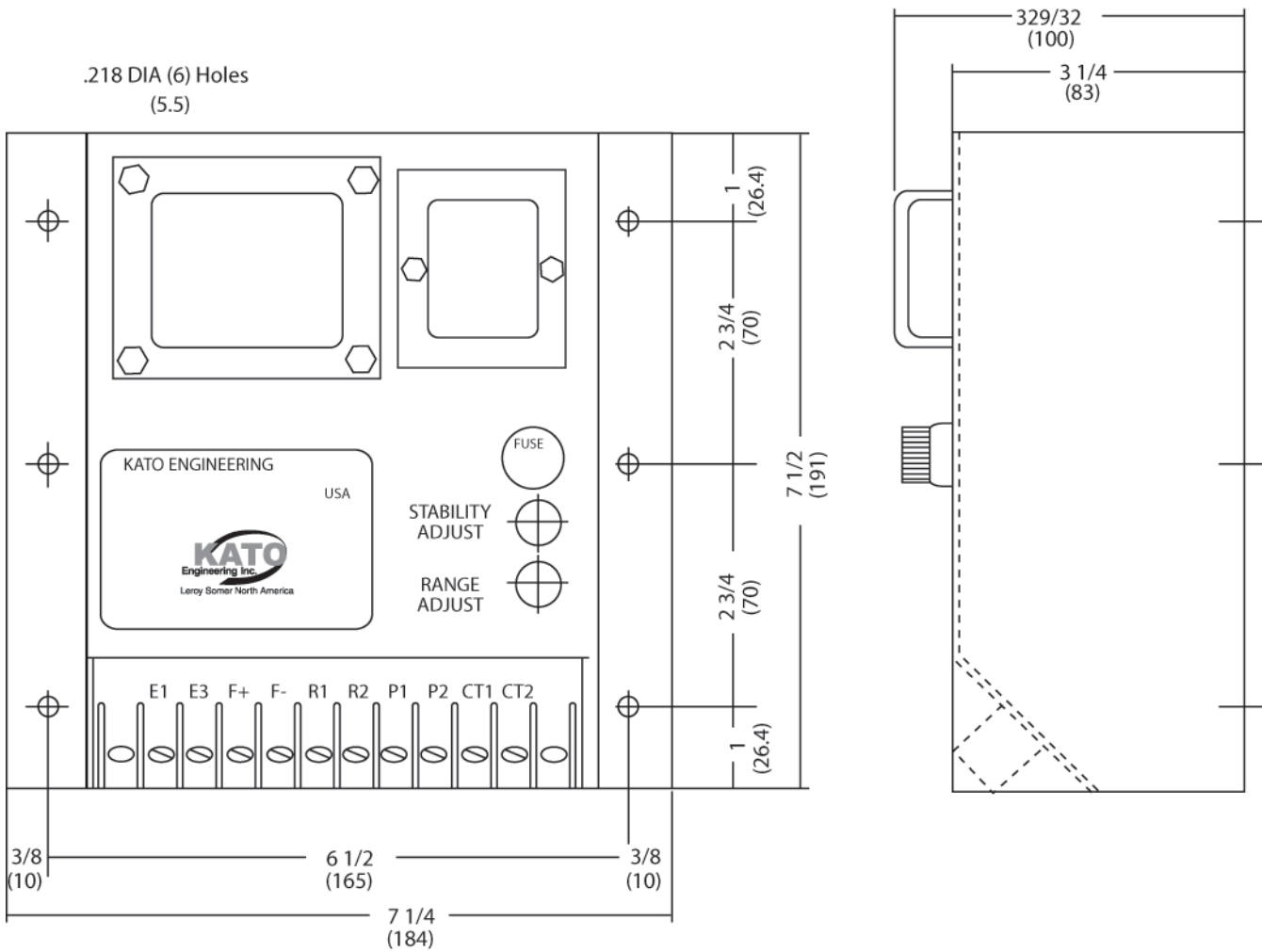

Figure 2: Outline drawing

Operating principles

Overview:

The voltage regulator senses the generator voltage, compares a rectified sample of that voltage with a reference voltage, and supplies the field current required to maintain the predetermined ratio between the generator voltage and the reference voltage.

The sensing circuitry also includes a transformer T2 and slide wire resistor R1. The transformer T2, resistor R1, and an external current transformer provide means of attaining reactive kVA load sharing during parallel generator operation. The parallel operation components do not affect voltage regulator operation when the generator is operated singly.

On regulators equipped with an underfrequency limit (UFL), the underfrequency circuitry interacts with the regulator sensing and error detector in a manner that decreases voltage during underspeed operation. A solid-state flashing circuit de-energizes when generator voltage has built up to about 70% of rated voltage output.

Operation of the various regulator circuits is described in detail in the paragraphs that follow. Most of the circuits are contained on a printed circuit board. Parts that are individually mounted on the regulator case are the sensing transformer T1, parallel operation transformer T2, parallel voltage droop slide-wire resistor R1, SCR/diode bridge assembly, and an electromagnetic interference filter. External voltage adjust rheostat VAR is provided for installation on a control panel. The circuitry described in the following paragraphs is shown on the electrical schematic of the voltage regulator (Figure 3) and on the electrical schematic of the underfrequency limit circuitry (Figure 4).

Sensing circuit during single generator operation: The voltage sensing transformer T1 provides a voltage proportional to the generator voltage output. This voltage is fed across the secondary of T2 to a full wave rectifier comprised of silicon diodes D3 and D4. The rectified voltage is filtered by resistors R3 and R4, and capacitor C1. The dc signal from the filter is applied to the error detector and the underfrequency limit.

Shorting the secondary parallel operation transformer T2, either by using the jumper bar across CT1 and CT2 or setting unit/parallel switch to UNIT position (closed), eliminates the effect of T2 during single generator operation.

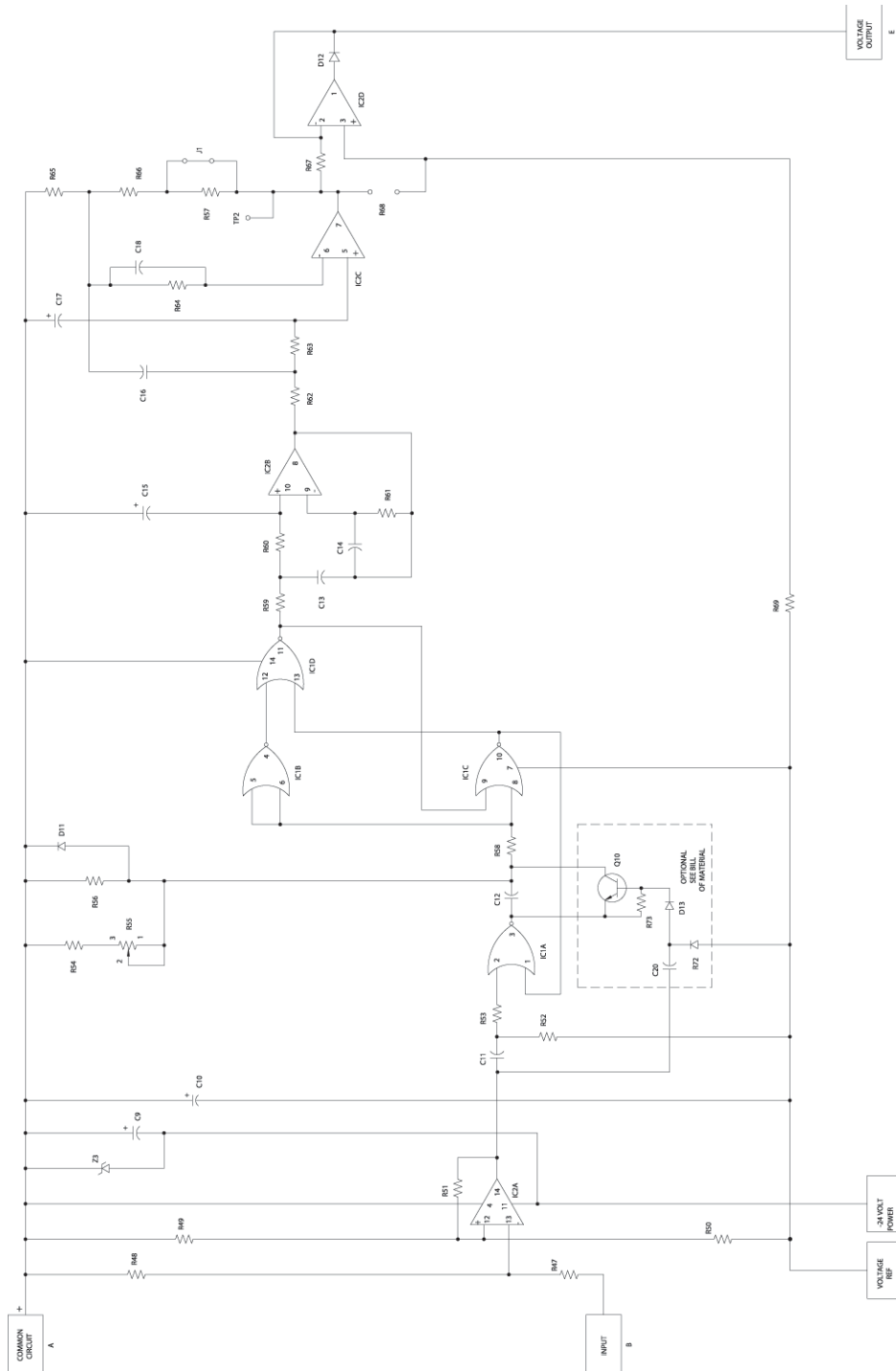

Figure 4: Underfrequency limit (UFL) electrical schematic

Sensing circuit during parallel generator operation in reactive voltage droop compensation mode: Generators interconnected as shown in Figure 5 for reactive voltage droop compensation will proportionally share inductive reactive loads during parallel operation by a decrease in generator system voltage.

Sensing transformer T1 provides a voltage proportional to the sensing voltage applied to regulator terminals E1 and E3. A current transformer (CT) installed in line 2 of the generator develops a signal that is proportional in amplitude and phase to the line current. The signal develops a voltage across the slide-wire parallel voltage droop adjust resistor R1. The tap on R1 supplies part of this voltage to the primary of transformer T2.

The voltage developed in the secondary of T1 and the voltage developed in the secondary of T2 add vectorially. This action provides a voltage to the rectifier that is the vector sum of the stepped down sensing voltage and the parallel current transformer signal through T2. The sensing rectifier dc output is filtered and applied to the error detector and underfrequency limit.

When a unity power factor (resistive) load is connected to the generator, the voltage that appears across the droop resistor leads the sensing voltage by 90 degrees, and the vector sum of the two voltages is nearly the same as the original sensing voltage; consequently, almost no change occurs in generator output voltage.

When lagging power factor (inductive) load is connected to the generator, the voltage across the droop resistor becomes more in phase with the sensing voltage, and the combined vectors of the two voltages result in a larger voltage being applied to the sensing rectifiers. Since the action of the regulator is to maintain a constant voltage at the sensing rectifiers, the regulator reacts by decreasing the generator output voltage.

When a leading power factor (capacitive) load is connected to the generator, the voltage across the droop resistor becomes out of phase with the sensing voltage and the combined vectors of the two voltages result in a smaller voltage being applied to the sensing rectifiers. Then the regulator reacts by increasing the generator voltage.

During parallel operation of two or more generators interconnected for reactive voltage droop, if field excitation on one of the generators should become excessive and cause a circulating current to flow between the generators, the circulating current will appear as an inductive load to the generator with excessive excitation and a capacitive load to the other generator(s). The parallel components R1 and T1 will cause the voltage regulator of the generator with excessive field excitation to decrease

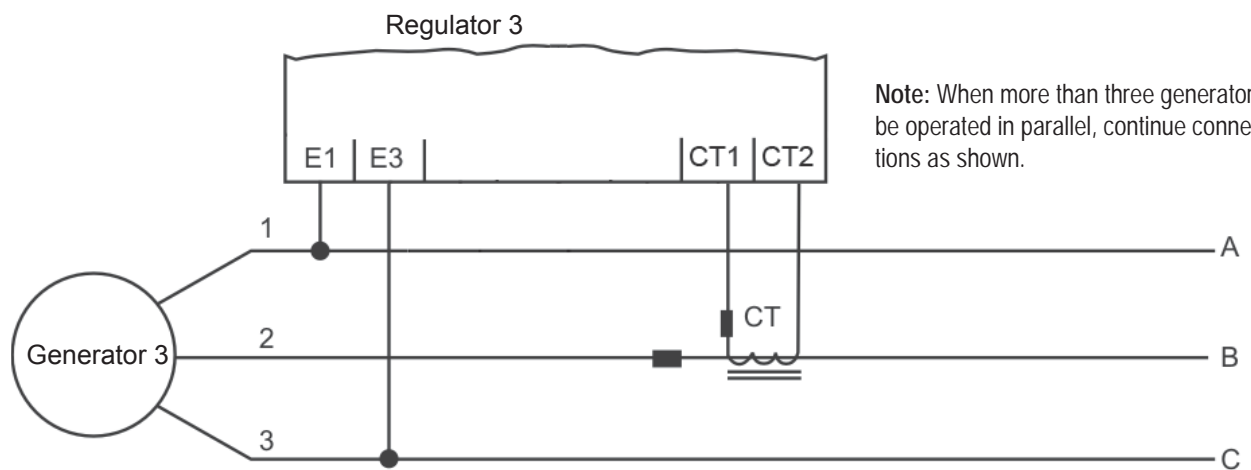
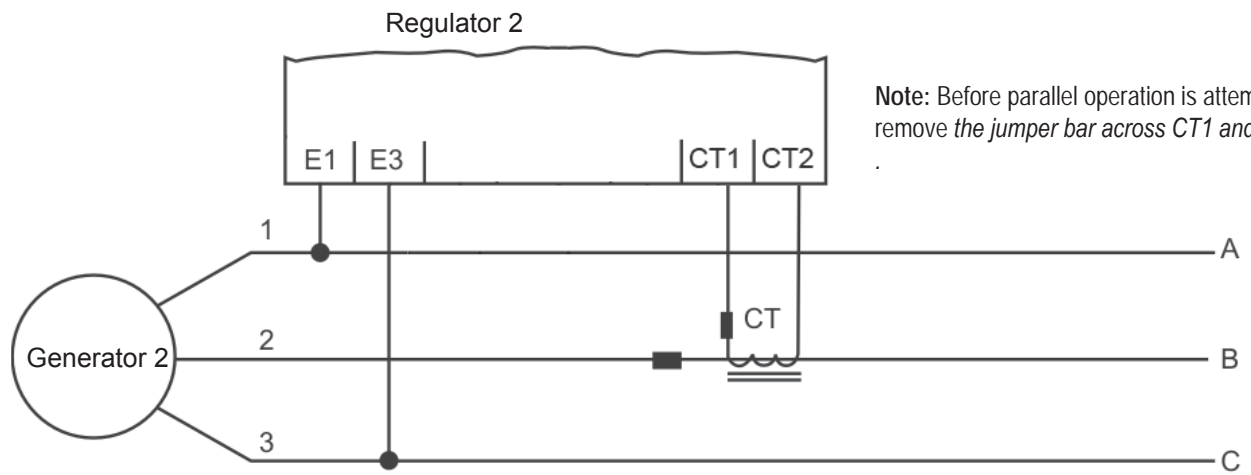
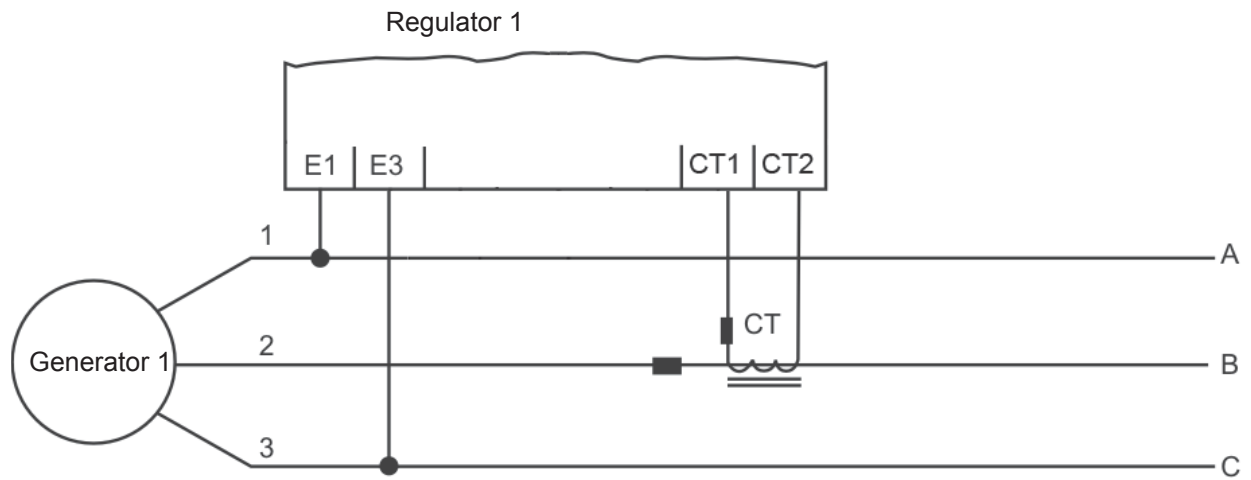

Figure 5: Parallel voltage droop CTs interconnection

excitation and generator voltage while the voltage regulators of the other generator(s) will react so as to increase excitation and generator voltage.

Sensing circuit during parallel generator operation in parallel cross-current compensation mode: Parallel cross-current compensation allows two or more paralleled generators to share inductive reactive loads with no droop or decrease in the generator system output voltage when the line currents are proportional and in phase. This is accomplished by the action and circuitry described previously for parallel reactive voltage droop compensation and the interconnection of the current transformer secondaries in a closed series loop as shown in Figure 6. Circulating currents cause the system to react as described previously for parallel voltage droop compensation.

A unit/parallel switch connected in each generator system (as shown in Figure 6) eliminates the series resistance of the current transformers in shut down generator sets from the current transformers of the generator sets that are operating.

Error detector: The error detector circuitry consists of a voltage adjust circuit, a voltage divider, a two-stage differential amplifier, and an internal minor feedback filter. The voltage adjust circuit consists of an external voltage adjust rheostat VAR, a voltage range adjustment R2, and fixed resistor R1.

Full travel of the external voltage adjust provides 10% adjustment of the generator output voltage from nominal. The voltage range adjustment R2 establishes the maximum and/or minimum voltage adjust limit of VAR. The voltage adjust circuit and a voltage divider consisting of resistors R5 and R71 determine the input signal to the first differential amplifier.

The first differential stage is comprised of transistors Q1 and Q2, resistors R9 through R18, R21, R22, R23, capacitor C3, diode D15, and the circuitry within the underfrequency limit. Underfrequency limit (UFL) provides a reference voltage to the base of transistor Q2 as described in “Underfrequency Limit” in this section. During generator operation at rated frequency the reference signal is constant and almost identical to the voltage across Zener diode Z1. Voltage from the sensing circuit which is proportional to the generator voltage is applied to the base of transistor Q1. When Q1 base voltage is different from the reference voltage applied to the base of Q2, there will be a difference in Q1 collector current with respect to Q2 collector current.

The current from the collector of transistor Q1 is divided by resistors R9 and R16 and injected into the base of the second stage differential amplifier transistor Q3. Similarly, the current from the collector of transistor Q2 is divided by resistors R14 and R15 and injected into the

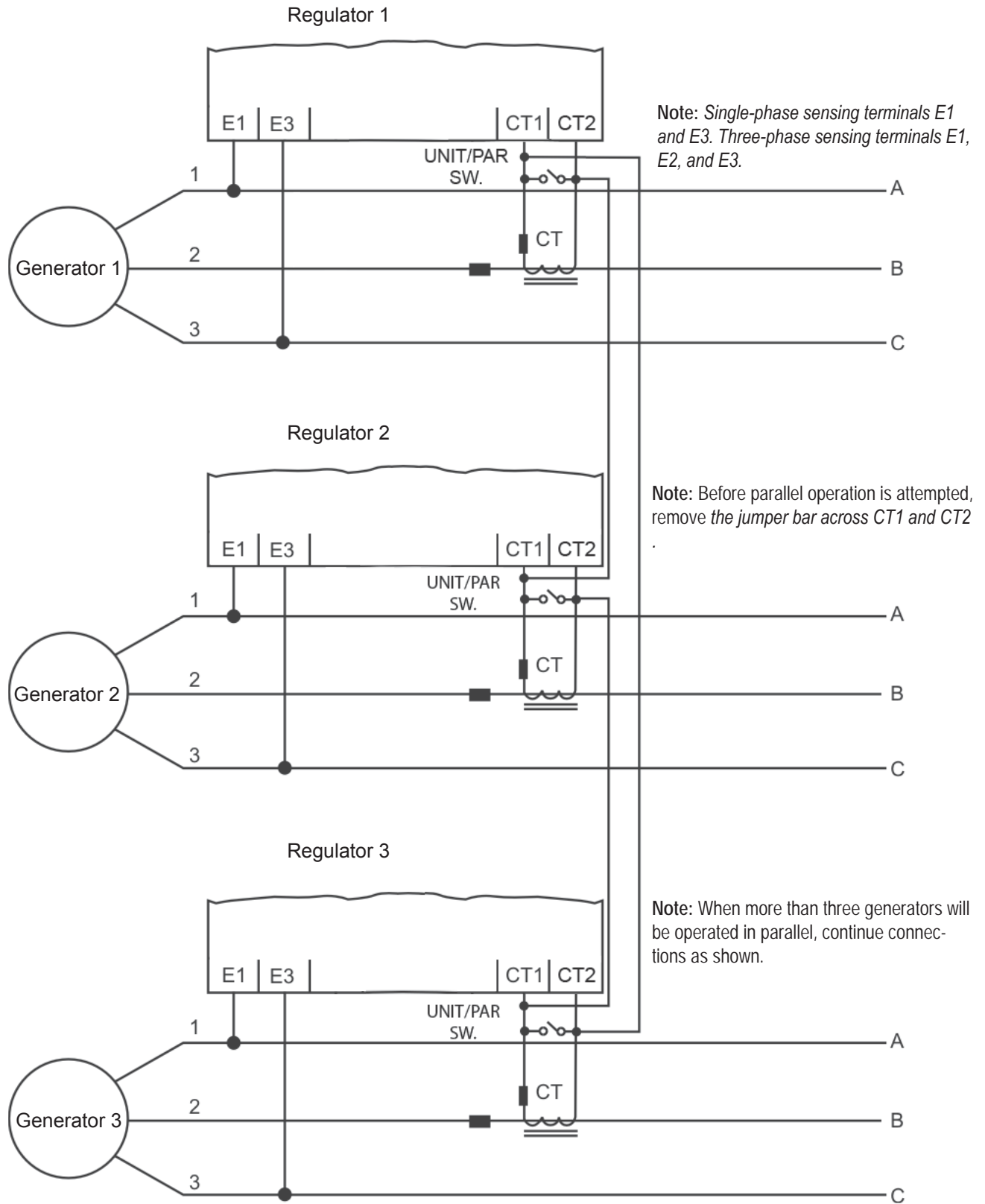

Figure 6: Crosscurrent CTs interconnection

second stage differential amplifier transistor Q4. Resistors R10 and C3 help to prevent oscillations at high frequencies. The second stage differential amplifier amplifies the output of the first stage differential amplifier. Components included in the second stage differential amplifier are transistors Q3 and Q4, and resistors R24 through R27. The collector voltage of transistor Q3 controls the phase control circuit. The minor feedback filter consists of resistor R8 and capacitor C2. The filter removes any remaining ac from the dc signal.

Phase control circuit: The phase control circuit consists of diodes D5 and D6, resistors R28 through R32, capacitors C6 and C7, Zener diode Z1, and the circuitry within the underfrequency limit.

The phase control circuit is a “ramp and pedestal” control that regulates the phase angle of the power controller circuit SCRs by controlling the “turn on” signal it supplies to the gate of the SCRs. An exponential ramp voltage that starts from a voltage pedestal provides the “turn on” gating signal. Because the ramp voltage starts from the voltage pedestal, a small change in the amplitude of the pedestal voltage results in a large change in SCR phase angle as illustrated in Figure 7.

The amplitude of the pedestal voltage is determined by the collector current of second stage differential amplifier transistor Q3. Zener diode Z2 serves as a voltage clamp, and resistors R31 and R32 are a voltage divider which determines the threshold of the programmable unijunction transistor Q5. The output of PUT Q5 is applied to the gate of the power controller SCRs through resistors R43 and R44.

Power controller: The power controller is the output stage of the voltage regulator. It is an SCR/diode bridge assembly consisting of silicon controlled rectifiers SCR1 and SCR2 and diode assemblies DB1-1 and DB1-2, diode D10, and capacitors C21 and C22. The output of the power controller is regulated by the “turn on” gating signal its SCRs receive from the phase control circuit.

Field flashing circuit: The flashing circuit includes silicon controlled rectifier SCR1, field effect transistor (FET) Q6, transistors Q7 through Q9 and Q11, resistors R34 through R42 and R74, and diodes D7 and D14.

Transistors Q8 and Q9, and resistors R34, R36, R37, R38, R40, and R41 comprise a Schmidt trigger circuit. The Schmidt trigger turns on when an increasing voltage is present with magnitude approximately 70% of the nominal 24 Vdc output of the sensing rectifiers. It turns off when a decreasing voltage is present with magnitude of approximately 30% of the nominal output of the sensing rectifier.

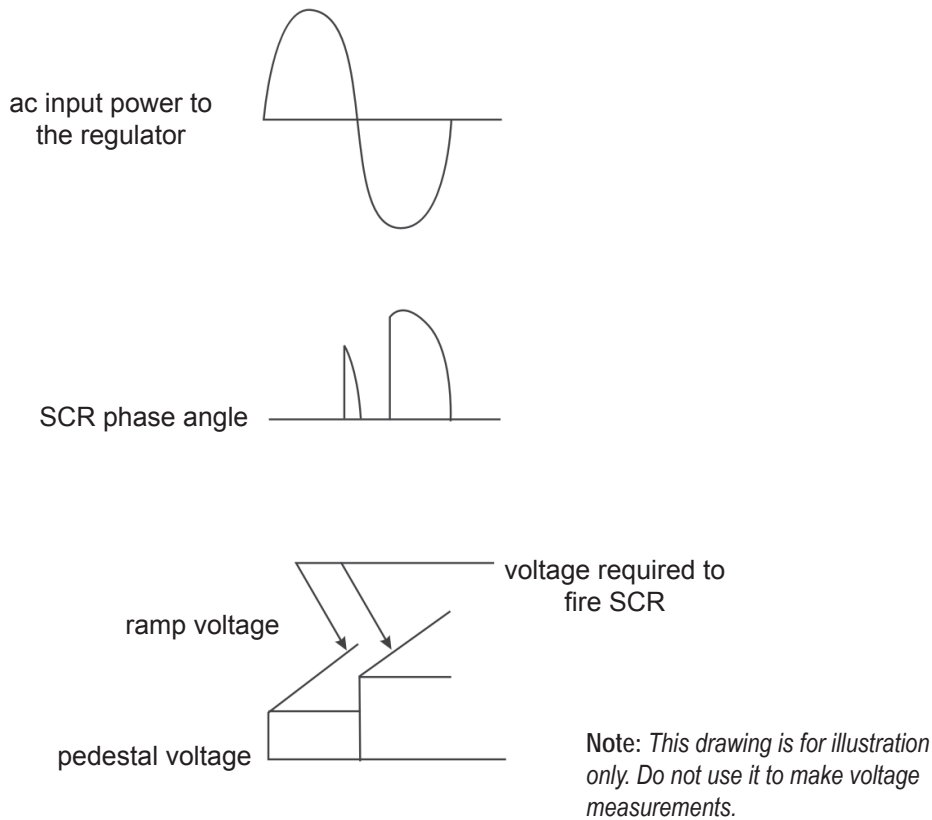

Figure 7: Change in SCR phase angle with change in phase control circuit pedestal voltage

When the Schmidt trigger is off, FET Q6 is on, turning on transistor Q7 and Q11, which supplies current to fire slave SCR1 located on the circuit board. Slave SCR1 fires the silicon controlled rectifiers SCR1 and SCR2 in the regulator power controller circuit, which, when on, supply current to the exciter field.

When the Schmidt trigger turns on, FET Q6 turns off. This action turns off transistor Q7 and Q11, which removes the gating signal to slave SCR1 and in turn the gating signal of the flashing circuit from the power controller SCRs.

Resistor R70 and capacitor C19 provide assistance in the firing of the power controller SCRs. Capacitor C8 and resistor R45 assist in limiting conducted EMI. Diodes D8, D9, and those in the SCR/diode bridge assembly supply power to the flashing and phase control circuits. Diode D10 is a free-wheeling diode for inductive load transient voltage suppression.

Stability control: The stability circuit is a rate feedback RC network. It consists of capacitors C4 and C5, resistors R7, R19, and R20, and stability adjust potentiometer R6. This RC network injects a stabilizing signal from the regulator output, which helps to prevent generator voltage oscillation.

Underfrequency limit (UFL): The UFL provides a reference voltage to the error detector and is constant when the generator output frequency is higher than a predetermined limiting frequency. When the generator is operating slower than the predetermined limiting frequency, the UFL will provide the error detector with a reference voltage that is proportionally lower.

The reference voltage to the UFL is supplied by Zener diode Z1. The predetermined frequency where limiting starts for standard 50 Hz, 60 Hz, and 400 Hz KCR 360 regulators is given on page 7.

The voltage from the sensing transformer is rectified by diodes D1 and D2, and the rectified signal is applied to a Schmidt trigger consisting of operational amplifier IC2A, and resistors R47 through R51. A square wave is generated at the output of IC2A at double the frequency of the sensing voltage. This square wave is differentiated by capacitor C11 and resistor R52, making a fast rise time pulse for each input square pulse.

A quad nor gate integrated circuit IC1, resistors R53 through R59, diode D11, and capacitor C12 make up the monostable multivibrator. The monostable multivibrator output pulse is uniform in amplitude and duration for each input pulse. Thus, the average voltage level of the collective pulses at the output of the monostable multivibrator is directly proportional to the frequency of the pulses.

The output of the monostable multivibrator is fed into a four-pole Butterworth low pass filter comprised of operational amplifier IC2B and IC2C, resistors R60 through R66, and capacitors C13 and through C18. This filtering circuit does the actual averaging of the collective pulses from the monostable multivibrator. Amplifier gain is set at a level where its output equals the Zener referenced at rated 60 Hz or 400 Hz operation by resistors R65, R66, and capacitor C16. When operated at rated frequency of 50 Hz, the circuit is set for 50 Hz operation by removing jumper J1. This action adds R67 to the circuit.

Diode D12 and integrated circuit IC2D form a voltage clamping circuit. If the voltage from the Butterworth filter is equal to or greater than the Zener reference, the UFL output to the error detector will be the same as the Zener reference and the UFL will have no effect on regulator operation. However, when the voltage from the filter decreases, as occurs during underspeed operation of the generator, the reference voltage applied to the error detector is less than the Zener reference. This action will cause the error detector differential signal to increase in a manner

that results in a proportionally later turn-on signal to the regulator output SCRs. The regulator then decreases excitation, and a lowering of generator output voltage occurs.

Resistors R54 and R56, potentiometer R55, diode D11, and C12 determine the underfrequency limit operational threshold. Zener diode Z3 and capacitors C9 and C10 protect the integrated circuits from damage should excessive voltage spikes occur.

Volts-per-hertz sensing option: Where this option is included, the volts-per-hertz circuitry interconnections within the regulator are the same as the UFL circuit shown in Figure 3. The volts per hertz circuitry is identical to the UFL circuitry shown in Figure 4 except R67 and R69 are omitted, R68 is installed, and D12 is replaced with a jumper. IC2D then operates as a buffer amplifier. The output voltage to the error detector will be proportional to the generator frequency. Where the volts-per-hertz option is provided, voltage will be proportional to frequency from rated frequency down to approximately one-half rated frequency.

Flat regulation for constant voltage variable frequency application: Where this option is included, the underfrequency limit circuitry (UFL) shown in Figure 3 and Figure 4 is not included. A fixed reference voltage from Zener diode Z1 and across resistor R17 is applied to the reference side of the error detector (transistor Q2). Where this option is included, a decrease in frequency will not result in drop in voltage. Minimum frequency that can be attained while maintaining rated voltage will depend on voltage regulator capacity and saturation characteristics of the exciter and generator.

Installation

Mounting: The voltage regulator can be mounted in any position without affecting its operating characteristics. The voltage regulator is convection cooled. Retain sufficient space around the regulator for heat dissipation and for making electrical connections and controls adjustments. Mount the voltage regulator in any location where shock and vibration are not excessive and the ambient temperature does not exceed its ambient operational limits.

Warning: *De-energize the generator set starting circuit before making repairs, connecting test instruments or removing or making connections to or within the voltage regulator. Dangerous voltages are present at the voltage regulator terminal boards and within the voltage regulator when the generator set is running. These include the sensing voltage, power to the voltage regulator, and the voltage regulator output. Accidental contact with live conductors could result in serious electrical shock or electrocution.*

Caution: *Do not use a megger or high potential test equipment when testing the voltage regulator. Disconnect interconnecting conductors between the generator and voltage regulator when testing the generator or exciter with a megger or high potential test equipment. The high voltage developed by megger or high potential test equipment will destroy the solid-state components within the voltage regulator.*

Caution: *Do not open the regulator sensing circuit while power is applied to the regulator input power terminals. Loss of sensing voltage will result in maximum regulator output.*

Interconnection: Connect the regulator to the generator system as instructed in this section and as shown in the connection diagram provided with the generator set. See Figure 2 for an overall outline drawing that shows the location of regulator mounting provision and parts of the voltage regulator. See Figures 8 for a typical interconnection diagrams and Figures 3 and 4 for electrical schematics of the voltage regulator. Use 14 gauge or larger wire for connections to the voltage regulator.

Sensing (terminals E1 and E3): Standard KCR 360 voltage regulators have an internal sensing transformer provided with taps on the primary winding for sensing voltages of 100 to 139, 200 to 228, 216 to 265, 375 to 458, 432 to 528, and 540 to 600 Vac. The transformer taps are identified with the corresponding nominal voltages, which are 120, 208, 240, 416, 480, and 600 Vac. To obtain proper operation, make sensing connections as follows:

- Connect the internal wire from voltage regulator terminal E3 onto the correct tap on sensing transformer T1.
- For operation with generator voltages above 600 volts, use a potential transformer of metering quality to supply the regulator sensing voltage. The sensing circuit load is less than 6 VA. Maintain correct polarity to the voltage regulator sensing input.
- For precise voltage regulation, the sensing leads should be connected as close as possible to the point where regulation is desired. The regulator regulates according to the voltage that is applied to its sensing terminals. Therefore, it cannot correct for voltage drop in leads that may occur at points beyond the point where regulator sensing is obtained. Do not use the leads that supply regulator sensing to supply power to any other equipment or to the regulator power stage.
- In applications where regulator sensing leads are connected beyond the output side of the generator circuit breaker and when regulator power is obtained from the generator, connect the leads that provide regulator power at points beyond the output side of the generator circuit breaker.

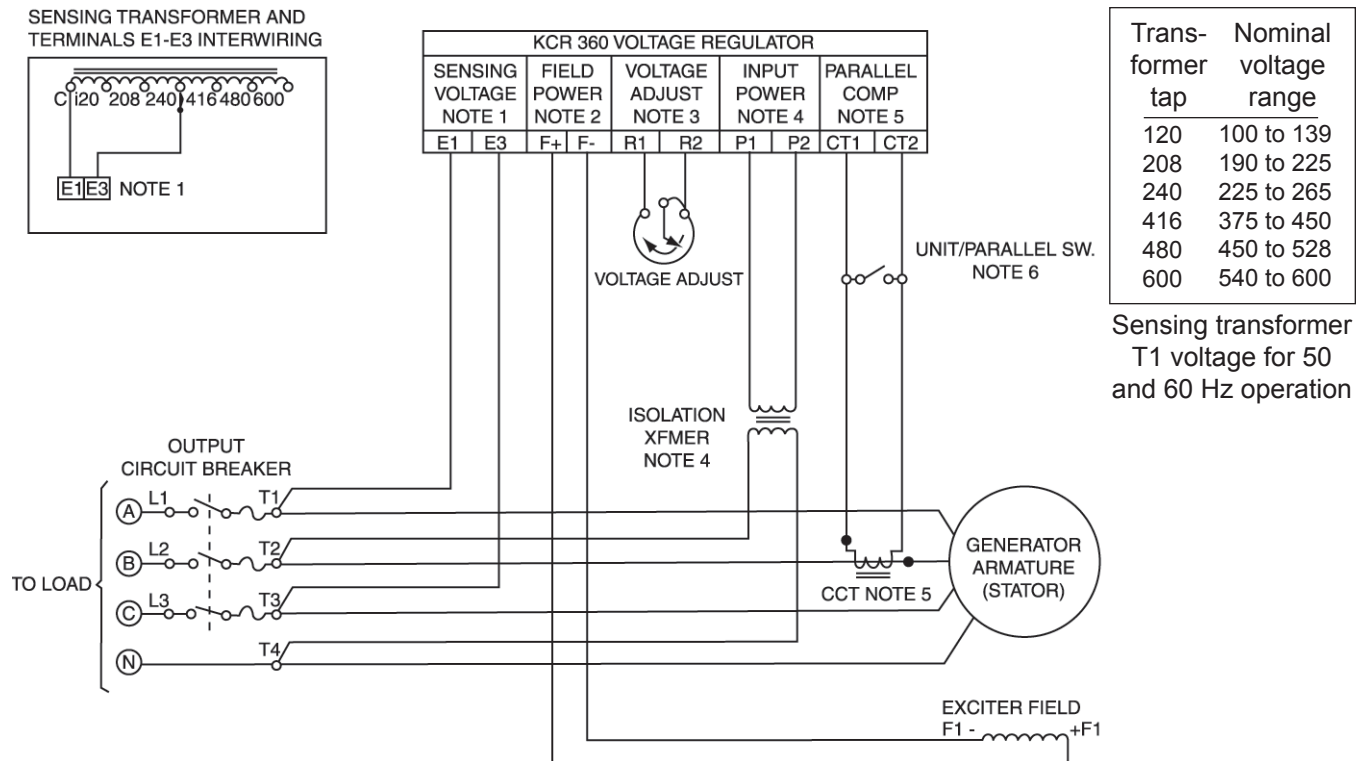

Figure 8: Typical KCR 360 voltage regulator and brushless generator interconnection

- If the generator is to be operated in parallel with other generators, the phase relationship of sensing voltage and the parallel operation current transformers is very important. (Refer to “Connection to Terminals CT1 and CT2” in this section).

Warning: *Electromagnetic interference capacitors are connected between the line and ground. To eliminate electrical shock hazard, connect the regulator chassis to the system power ground.*

Input power (terminals P1 and P2): The voltage regulator operates from single phase 100 Vac to 139 Vac input power applied to terminals P1 and P2. If the correct voltage is not available or if the field is grounded, use a power isolation transformer. The transformer is not furnished with the regulator but can be ordered from Kato Engineering.

Grounding: The power input leads are electromagnetic interference filtered. A good electrical power ground is not necessarily a good interference ground. Make sure ground leads are as short as possible, preferably of copper strap with a width 1/5 the length. Grounding the system to earth ground makes all grounds common.

Output power (terminals F+ and F-): Make sure the field resistance is not less than 10 Ω and correct polarity is maintained between the regulator output and exciter field. Because the regulator output leads are not connected to any part of the system except the exciter field, they are not filtered. To minimize conducted EMI, keep the leads as short as possible and shielded. Effective shielding can be attained by routing both leads through 0.5 inch conduit. In general, not more than 1 to 2 feet of field leads should be unshielded. If the voltage regulator is installed within the generator outlet box, it is possible to achieve satisfactory results with short unshielded leads.

External voltage adjust rheostat (terminals R1 and R2): Terminals R1 and R2 provide connection of the voltage adjust rheostat. The rheostat provides adjustment of the regulated generator voltage $\pm 10\%$ of nominal. It is provided as a separate item for panel mounting. Connecting wires from the rheostat attach to terminals R1 and R2. Connect a jumper wire between the rheostat wiper arm terminal and the rheostat terminal that is common with regulator terminal R2.

Connection to terminals CT1 and CT2 (generators operating singly and parallel): The KCR 360 voltage regulator is supplied with a jumper across terminals CT1 and CT2. Electrical connections to terminal CT1 CT2 are as follows:

- For generator operating singly, install the jumper bar across terminals CT1 and CT2.
- For parallel operation of generators, remove the jumper bar, and then connect the secondary of a current transformer to terminals CT1 and CT2. The current transformer is connected in the generator line that does not supply sensing to the regulator and should deliver 1 A secondary current at rated load. The phase relationship of the current

transformer signal to the regulator sensing voltage must be correct or the systems will not parallel properly. Figures 5 and 6 show the correct polarity for A-B-C (1-2-3) phase rotation. If the phase sequence is not A-B-C (1-2-3), interchange the current transformers secondary leads.

Reactive voltage droop: Connect the current transformer to its respective regulator as shown in Figure 5.

Cross-current compensation: For cross-current, connect each CT to its respective regulator. Then connect the finish of the first CT to the start of the second CT, the finish of the second CT to the start of the third CT, etc. Continue until all CT's are connected in series and connect the finish of the last CT to the start of the first CT (see Figure 6).

On parallel cross-current compensation applications consisting of two or more generators, use a unit/parallel switch if all the generators are not always on the bus. If the switch is not used, a voltage droop will be introduced into the system, which will cause the voltage of the incoming generator to fluctuate prior to paralleling. This is due to the unloaded generator parallel CT not supplying its compensating signal, but allowing a voltage drop to occur across it. Ideally, the switch is an auxiliary on the generator output circuit breaker that opens when the breaker is closed.

Underfrequency limit (UFL): The underfrequency limit components are located on the voltage regulator circuit board (see Figures 3 and 4). Use of jumper wire J1 is as follows:

50/60 Hz sensing, voltage regulator operating 60 Hz: Make certain a jumper wire is installed across area marked J1. The wire is mounted on component side of circuit board, and the ends of the jumper wire are soldered onto the film side of the circuit board.

50/60 Hz sensing, voltage regulator operating 50 Hz: Make certain jumper wire J1 is removed. Remove J1 by cutting each end of the jumper wire.

400 Hz sensing voltage regulator: Make certain jumper wire J1 is installed.

Voltage regulator fuse: The voltage regulator contains an 8 A normal blow fuse in the voltage regulator input power circuit (see Figure 3). In applications where voltage regulator power requirements are reduced, as when used with small generators where excitation is less than given, a smaller fuse may be used. Never install a fuse larger than 8 A, and never install a delay-type fuse.

Warning: Fire hazard can exist if the voltage regulator fuse is larger than 8 A or if a delay type fuse is used.

Note: On generator systems that include the auto/manual voltage control option, the OFF position on the AUTO/OFF/MANUAL selector switch provides voltage shutdown. On generator systems that include a field circuit breaker, manually tripping the circuit breaker OFF provides voltage shutdown.

Caution: Never install the voltage shutdown switch in the exciter field circuit. Do not open the voltage regulator dc output (terminals F+ and F-) during operation.

Caution: Never open the voltage regulator dc output (terminals F+ and F-) during operation. Doing so would produce inductive arcing that could destroy the exciter or voltage regulator. Never place circuit breaker contacts in the exciter field circuit.

Accessory items: Connect accessory items provided with the generator system as shown on the wiring diagram provided with the generator set and the accessory item drawing or instruction.

Voltage shutdown (engine idle switch): The system can be equipped with a switch to allow removal of excitation in an emergency or when the prime mover must be operated at reduced speeds. This switch must be placed in the input power line to the regulator (terminal P1 or P2).

Field circuit breaker: The field circuit breaker must be of the type that has separate terminals for the thermal element and the contacts. The circuit breaker thermal element can be either of the following types:

1. Field current heats the thermal element: The thermal element connects between the voltage regulator output and the exciter field.
2. Generator line current heats the thermal element: The thermal element connects to a current transformer located in one of the generator load lines.

Auto/manual voltage control: The auto/manual voltage control option includes the components described in the paragraphs that follow. Connect the auto/ manual voltage control module as shown on the wiring diagram provided with the generator.

1. Three-position selector switch - When the switch is set to the AUTO position, power is fed across the switch contacts to regulator input power terminals P1 and P2. When the switch is set to MAN, power is fed across the switch contacts to the manual voltage control circuit rectifiers. OFF position opens input power to both the voltage regulator and the manual voltage control rectifiers.
2. Manual voltage control circuit - The manual voltage control circuit consists of a full wave rectifier assembly and a manual voltage control variac. The manual voltage control variac controls generator output whenever the generator set is operated in the manual voltage control mode.

Operation

Adjustments: The adjustments pertaining to the voltage regulator and system operation are described in the paragraphs that follow and, except where noted, adjustment is made during initial operation and normally does not have to be repeated during the life of the voltage regulator.

Caution: Before initial operation, verify that the regulator is connected for the application. See wiring diagram provided with the generator set and review the procedures given above.

Generator voltage adjust rheostat (VAR): This adjustment is provided to control the generator voltage. When set to its maximum counterclockwise position, minimum generator voltage is obtained. Maximum generator voltage is obtained when the rheostat is set to its maximum clockwise position.

Nominal voltage range set adjust (R2): This adjustment is provided to extend the limits of the generator voltage adjust rheostat (VAR). Normally R2 is set to provide the generator voltage adjust rheostat with an adjustment range of $\pm 10\%$ of rated voltage. R2 is located on the regulator. Loosen the 1/2 inch locknut before attempting to adjust R2 (with a small screwdriver). Retighten the locknut after adjustment is complete.

Stability adjustment (R6): Stability control R6 provides for stable regulating operation by controlling the amount of feedback that is applied to the error detector stage. Turning the control counterclockwise decreases the amount of the stability feedback, making the regulator respond faster.

This control is located on the regulator circuit board and is adjustable through a hole in the top of the regulator case. Loosen the 5/16 inch hex-head locknut that keeps the control shaft from turning due to vibration before attempting to adjust R6 (with a screwdriver). Retighten the locknut after adjustment is complete.

Operate the generator at rated frequency, no load, the point at which the stability adjustment is most critical. Adjust STABILITY by first rotating the control fully clockwise with screwdriver. One end of the screwdriver slot will point to 2 o'clock; this end is the pointer. Set the STABILITY by rotating pointer counterclockwise to 10 o'clock. This setting normally ensures good stability, but may not provide optimum response time for the generator.

If the generator voltage oscillates (hunts), turn the control clockwise past the point where oscillation stops. If faster response is required, rotate the control counterclockwise until the voltage becomes unstable, and then rotate clockwise until the voltage is stable. Optimum adjustment is attained when generator voltage is stable and response is satisfactory at no-load and also during operation under any load up to the full load rating of the generator.

Operational threshold	dc voltage TP1-TP2
60 Hz	0.000
59 Hz	-0.080
58 Hz	-0.140
57 Hz	-0.218
56 Hz	-0.291
55 Hz	-0.360
54 Hz	-0.454
53 Hz	-0.534
52 Hz	-0.540
51 Hz	-0.720
50 Hz	-0.797

Table 2: Voltage across underfrequency limit terminals TP1-TP2 with a 60 Hz generator and 240 Vac sensing

Note: The jumper wire must be across J1 on a 60 Hz system. Measured voltage must be negative. Slight variation in operating threshold may exist due to circuit and meter tolerances.

Operational threshold	dc voltage TP1-TP2
50 Hz	0.000
49 Hz	-0.085
48 Hz	-0.177
47 Hz	-0.267
46 Hz	-0.364
45 Hz	-0.456
44 Hz	-0.558
43 Hz	-0.672
42 Hz	-0.789
41 Hz	-0.897
40 Hz	-1.008

Table 3: Voltage across underfrequency limit terminals TP1-TP2 with a 50 Hz generator and 200 Vac sensing

Note: The jumper wire J1 must be removed during 50 Hz operation. Measured voltage must be negative. Slight variation in operating threshold may exist due to circuit and meter tolerances.

Caution: Do not attempt to flash the exciter field while the generator set is running. Be careful to observe polarity when connecting flashing source. Accidental polarity reversal will destroy the voltage regulator power stage.

Parallel voltage droop resistor (R1): This adjustment is provided to control the voltage droop signal of generators operating in parallel. It is located at the lower section of the generator case. Maximum voltage droop is attained when the resistor is set to its maximum resistance position. Adjust each generator that will be operated in parallel for identical voltage droop as described in the parallel operation procedure that follows. Make the adjustment by loosening the slider screw with a screwdriver, moving the slider, and then tightening the slider screw after adjustment has been made.

Underfrequency Adjustment (R55): This adjustment is included in voltage regulators provided with the underfrequency limit option. R55 is adjusted at the factory as listed above or as requested in the generator purchase order.

- Adjusting the underfrequency limit when the generator frequency can be set to the desired breakpoint:
 1. Connect a voltmeter between the circuit board terminals TP1 and TP2.
 2. Run generator at the desired underfrequency limit set point (for example 58 Hz).
 3. Adjust R55 for 0 volts as indicated on the meter.

- Adjusting the underfrequency limit when generator frequency can not be adjusted.
 1. Connect a voltmeter between the circuit board terminals TP1 (negative) and TP2 (positive).
 2. Run the generator at rated speed and voltage.
 3. Determine the desired underfrequency limit setting voltage from Table 2 for 60 Hz generators or Table 3 for 50 Hz generators.
 4. Adjust R55 until the voltage between TP1-TP2 equals the test voltage given in the appropriate table. EXAMPLE: With unit running at 60 Hz and where limiting is desired at about 55 Hz, the voltage across TP1-TP2 should be -0.360 Vdc.

Manual voltage control variac: This control is included in generators equipped with the automatic/manual voltage control option. During generator operation using the manual voltage control mode, the mode selector is set to MAN and generator voltage output is controlled by the manual voltage control variac. In order to maintain generator output voltage at a constant level during operation in the manual voltage control mode, adjust the manual voltage control variac each time a change in load occurs (either added or shed).

Field flashing: The voltage regulator contains an internal solid-state field flashing circuit. A minimum of about 6 Vac at the regulator input power terminals is required for operation of the flashing circuit. Usually the exciter field poles retain sufficient magnetism to allow circuit operation and generator voltage buildup. However, if flashing is required, stop the

generator, and then flash the field as given in the procedure that follows:

1. Connect the negative lead of a 12 or 24 Vdc flashing source onto regulator terminal F-. Do not remove any other wires from terminal F-.
2. Slide the positive lead of the flashing source onto the regulator terminal F+. Only a few seconds flashing should be necessary.
3. Slide the flashing source positive lead off terminal F+. Then remove the flashing source negative lead from terminal F-, and tighten the terminal.
4. Start the generator, and check for satisfactory voltage buildup.

Single unit initial operation: When the generator set is equipped with the automatic/manual voltage control option, normal operation of the generator set is the automatic voltage control mode. During generator set operation in the automatic voltage control mode, generator output voltage is pre-established during no-load operation by adjustment of the external voltage adjust rheostat and automatically maintained at the amplitude under all load conditions from no-load to full rated load by the voltage regulator.

Automatic mode operation: Review the preceding adjustment and single unit operation procedures. The general procedure for single unit automatic mode operation is as given in the procedure that follows:

1. If the generator set is equipped with the auto/manual control option, set the selector switch to AUTO.
2. Turn the voltage adjust rheostat to about one-half of the way between the maximum counterclockwise and maximum clockwise positions.
3. Open the output circuit breaker. Do not apply load until satisfactory no-load operation is attained.
4. If a voltage shutdown switch or field circuit breaker is used, close the switch to connect input power to the voltage regulator.
5. On generators that will be operated parallel and if the sets are equipped with unit/parallel switches, close the switch on all generators.
6. Start the prime mover and bring up to rated speed.
7. Verify generator voltage. Any of the following conditions can occur.
 - No voltage buildup: If this condition exists, the exciter may not have sufficient residual magnetism. Residual magnetism may be restored by flashing the field as described in the “Field Flashing” instructions.
 - Overvoltage ($\pm 15\%$ or more): If this condition occurs, open the shutdown switch immediately and/or stop the prime mover. Determine the cause of overvoltage.
 - Undervoltage (-15% or more): If this condition occurs, open the shutdown switch immediately and/or shut down the prime mover. Determine the cause of undervoltage.
 - Undervoltage by operation of the underfrequency limit circuit (UFL): Undervoltage by operation of the underfrequency circuit can occur if the prime mover governor is not adjusted to

Note: Deviation in generator output voltage approximately $\pm 10\%$ of rated can be corrected by adjusting the voltage adjust rheostat and if necessary, the voltage range set adjust.

maintain rated speed or when the underfrequency limit circuit is adjusted to operate at a frequency that is very close to the rated frequency of the generator.

- Voltage begins to build up and then collapses: If this condition exists, stop the prime mover and determine the cause of collapse. If necessary refer to troubleshooting procedure.
 - Oscillating voltage (hunting): If this condition occurs, be sure prime mover speed is not fluctuating. Then, if this condition persists, adjust the stability adjust (R6) as given in the stability adjustment section above.
8. Operate the generator set for about 1/2 hour.
 9. After about 1/2 hour of satisfactory operation, close the output circuit breaker and connect the load.
 10. Be sure the generator output voltage is correct and stable. Verify that steady voltage regulation is satisfactory.
 11. Remove the load.
 12. If the generator will be operating parallel, adjust the parallel operation resistor R1 as given in the steps that follow.
 13. If the generator set is equipped with a unit/parallel switch, open the switch.
 14. Monitor no-load voltage.
 15. Apply inductive load, and note the droop in generator voltage. A droop of about 6% is attained when R1 is set to maximum resistance and the current transformer secondary current is 1 amp.
 16. If droop is more than is required, set R1 for less resistance. If droop is less than required, increase resistance across R1 (see parallel voltage droop resistor R1 in this section).
 17. Repeat steps 14 through 16 as necessary to obtain required droop signal.
 18. To stop the unit, remove the load, open the output circuit breaker, and then stop the prime mover.

Manual mode operation: This test applies only to generator sets equipped with the auto/manual voltage control option. Normal operation of the generator set is in the automatic voltage control mode. The manual voltage control mode provides a means of operating the set should the voltage regulator fail. Test the manual control for proper operation during the initial operation of the set and determine whether cause of system malfunctions is due to a faulty generator or a faulty voltage regulator as follows:

1. Perform the preceding automatic mode operating procedure.
2. Open the output circuit breaker and, if it is running, stop the prime mover.
3. If it is included, close the unit/parallel switch.
4. Set the auto/off/manual selector switch to MAN.
5. Set manual voltage adjust variac to the complete counterclockwise position.
6. Start the prime mover, and bring it up to rated speed.
7. Turn the manual voltage adjust variac to the position where the

correct generator voltage is measured by the generator voltmeter.

8. Turn the manual voltage adjust variac to the position where voltmeter indicates generator voltage is about 5% higher than rated.
9. Close the output circuit breaker, and apply load.
10. Measure the output voltage. If it is not correct, adjust the manual voltage adjust variac.
11. Repeat steps 8 and 10 each time the load is increased.
12. Before shedding load, decrease generator voltage about 5% below rated.
13. Adjust manual voltage adjust variac to position where the voltmeter indicates generator is producing required voltage.
14. Repeat steps 12 and 13 each time any part of the load is shed.
15. Remove the load and open generator circuit breaker.
16. Set voltage adjust rheostat for rated generator output voltage.
17. Stop the prime mover.
18. Set the auto/off/manual switch to AUTO.

Parallel operation: The paragraphs that follow describe the procedures to operate two or more generators in parallel.

Metering: In order to attain satisfactory paralleling and to check for proper parallel operation all generators should be equipped with the following monitoring equipment:

1. ac voltmeter to measure generator output voltage (one per set)
2. ac voltmeter to measure bus voltage (one per system)
3. ac ammeter (one per set)
4. Power factor or kVAR meter (one per set)
5. kW meter (one per set)
6. Exciter field current dc ammeters (one per set)
7. Synchroscope or a set of lights to indicate when units are in phase

Checks before initial parallel operation: Before initial parallel operation, review the procedures and checks that follow:

1. Verify that each generator is connected to the bus with the same phase rotation as that of the bus. Use a phase rotation test instrument or an induction motor of known rotation during the initial single unit operation procedure.
2. Verify that the voltage regulating system of each generator is equipped with the parallel signal sensing transformer.
3. Make certain the paralleling signal at regulator terminals CT1 and CT2 have the proper phase rotation with that of the sensing voltage at terminals E1 and E3. In applications where units are connected for reactive voltage droop, verify that the connection is made as shown in Figure 5. Cross-current compensation application requires interconnection of the system as shown in Figure 6.
4. Prior to operation, set the parallel voltage droop resistor R1 on all regulators for identical droop. This can be accomplished by individually testing each generator set, one at a time, as given in the single unit initial operation procedure.

Preliminary parallel operation: Before attempting to parallel two or more generator sets, test individual sets to ensure that paralleling features function properly. The test that follows may be used:

1. On generating systems equipped with the auto/manual control option, verify that the switch is set to AUTO.
2. Verify that the jumper bar has been removed from across the regulator terminals CT1 and CT2.
3. On generating systems equipped with unit/parallel switches, verify that the switch on the generator set being tested is set to PAR (open), and be sure that the switch for each remaining generator is set to UNIT (closed).
4. Place the generator in operation as described in the section automatic mode operation.
5. Apply 25% to 100% unity power factor load to the set under test. The generator voltage should change less than 1%, and the frequency should decrease if the governor is set for droop operation.
6. Apply a 25% to 100% 0.8 P.F. inductive load. Voltage should droop. If the voltage rises instead of drooping, reverse the CT leads. If droop is not correct adjust parallel droop resistor R1 as described in the parallel voltage droop resistor adjustment procedure at the beginning of this section.

Paralleling generators: Review and understand these instructions and those contained in preceding paragraphs before attempting to parallel:

1. Set auto/off/manual switch on all generators to AUTO (generator set equipped with automatic/ manual voltage control option).
2. On generating systems equipped with unit/parallel switches, set the switch on unit being started (generator set No. 1) to PARALLEL (open). Set the switch on the remaining generator sets to UNIT (closed).
3. Start generator set No. 1.
4. Adjust the generator voltage and frequency to nominal.
5. Apply the load.
6. Verify satisfactory voltage regulation, and make certain frequency is not fluctuating.
7. Repeat steps 1 and 2 on generator set No. 2.
8. Start generator set No. 2.
9. Adjust generator set No. 2 frequency and voltage to nominal.
10. Adjust the speed of generator set No. 2 slightly higher than that of generator set No. 1.
11. Observing the synchroscope (or lights), when generator No. 2 is in phase with generator No. 1, close the circuit breaker for generator No. 2.
12. Immediately after closing the circuit breaker, measure the line current of generator No. 2. It should be well within the rating of the generator. Also, immediately after closing the circuit breaker, observe the kW or power factor meters. The following conditions could occur:

- A high ammeter reading accompanied by a large kW unbalance: When this condition exists, the speed governor is either not adjusted correctly or is faulty.
 - A high ammeter reading accompanied by a large kVAR unbalance: When this condition exists, the voltage regulating system is either not adjusted correctly or is faulty.
13. Adjust the speed of generator set No. 2 to the point where each generator is carrying the desired share of kW load.
 14. Adjust the voltage of generator No. 2 until the ammeter readings of both generators are near minimum.
 15. With full load applied, readjust the speed and voltage of generator No. 2 until the desired load division is obtained.
 16. In applications where three or more generators are to be operated parallel, repeat preceding steps 7 through 15 for generator set No. 3, then No. 4, etc.

Shutting down one or more generators operating in parallel: Before dropping one or more generators operating parallel from the line bus, reduce the total load on the bus to equal to or less than the combined capacity of the generators remaining on the bus. Shut down one or more of generator sets operating parallel as follows:

1. Reduce load to combined capacity of generators remaining on the bus.
2. On systems where the prime mover governor is equipped with a manual speed adjust, shift the load to generators remaining on the bus by reducing the speed of the generator set being dropped from the bus.
3. Open the circuit breaker on the generator set being taken off of the bus.
4. Close its unit/parallel switch (on generator sets equipped with a unit/parallel switch).
5. Shutdown the prime mover.
6. In applications where three or more generators are operated parallel, repeat preceding steps 1 through 5 for each generator set being taken off the bus.

Note: If kVAR or power factor meters are available, adjust the voltage adjust rheostats for equal or proportional kVAR or power factor readings. If the generators are equipped with power factor meters, alternately adjust the speed and voltage on no. 2 until the ammeter readings are proportional and the power factor readings are equal.

Note: To obtain best results, make the final adjustments with the full load on the bus.

Note: The best adjustment is obtained when each generator supplies the same percentage of its rated current, the power factor readings are equal, or the sum of the ammeter currents is minimum.

Maintenance

Preventive maintenance: Inspect the regulator periodically to ensure that air flow is not restricted. Dirt, dust, and other foreign material may be removed using low pressure (25 to 50 PSI) compressed air. Check the connections between the regulator and system periodically to ensure they are tight and free of corrosion.

Corrective maintenance: Make repairs to the regulator by following the figures in this manual. Due to a protective conformal coating, do not attempt repairs on the printed circuit board.

See Table 4 for a list of replacement parts.

On generator sets equipped with the auto/manual voltage control option, operation of the generator set in the automatic voltage control mode can be compared to how well it operates in the manual voltage control mode. Faulty operation in the automatic mode and satisfactory operation in the manual mode indicates a problem in the voltage regulator while, if faulty operation in both the automatic and manual voltage control mode occurs, the problem is probably within the exciter or generator.

Description	Part number
KCR 360 AVR	Per the nameplate
Sensing transformer T1	855-63610-02
Parallel operation transformer T2	855-11610-01
Parallel operation voltage droop adjust resistor	866-15035-10
Electromagnetic interference filter	514-00404-97
External voltage adjust rheostat, 250 Ω	867-32522-80
Printed circuit board (it is better to replace the AVR)	Consult the factory
Fuse, 8 A ABC	515-01208-31
Fuse holder	516-10035-00
SCR/diode bridge assembly (best to replace AVR)	Consult the factory

Table 4: Replacement parts list

Voltage regulator operational test: Use the following test procedure to determine if the regulator is basically operational:

1. Connect regulator as shown in Figure 9.
2. Connect internal wire from terminal E-3 to the 120 volt tap on sensing transformer T1.
3. Connect jumper across terminals CT1 and CT2.
4. Adjust the external voltage adjust for maximum resistance (complete counterclockwise position).
5. Connect light bulb across terminals F+ and F- and wires to terminal E1, E3, P1 and P2 as shown in Figure 9.
6. Connect to 120 Vac power source.
7. Turn the external voltage adjust clockwise. Before reaching the maximum clockwise position the bulb should come on to near full brilliance.
8. At the regulating point a small change in adjustment of the external voltage adjust rheostat should turn the light on or off. If the light does not come on or stays on at full brilliance, the regulator is probably defective.
9. Before re-installing in generating system, connect regulator as it was before steps 2, 3, and 4.

Troubleshooting: Between regular preventive maintenance inspections, be alert for any signs of trouble. Correct any trouble immediately. See Table 5 for typical symptoms, causes and remedies.

Note: Incorrect electrical connections between the generator system and the regulator and poor electrical connections are often the cause of system malfunction. Before assuming a failure of the generator or regulator has occurred, check wiring against the wiring diagrams provided with the generator set and the instructions given above. Also make certain all connections are tight and free of corrosion.

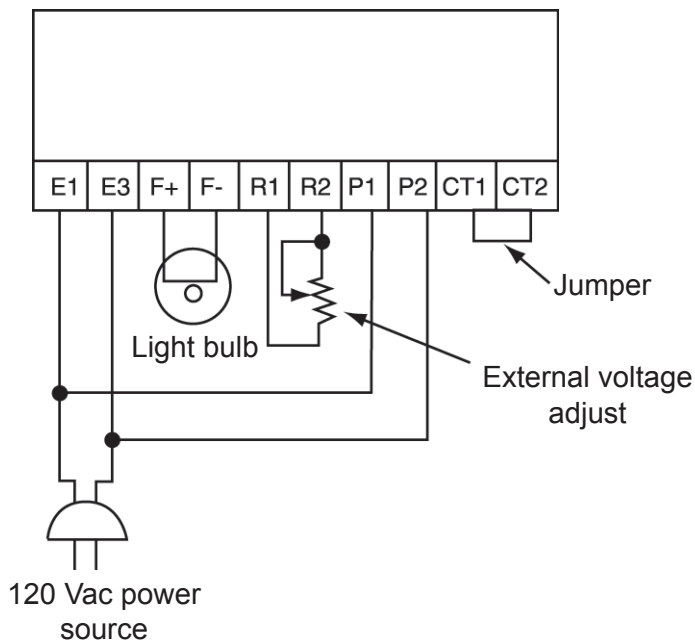

Figure 9: Operational test connection diagram

Symptom	Cause	Remedy
Voltage does not build up to rated value	Shutdown switch is open	Close the switch.
	Fuse is blown	Replace the fuse. If the fuse blows repeatedly, determine the cause of the overload.
	Auto/off/manual switch is on OFF	Set to the switch to AUTO.
	Field circuit breaker is open	Close the circuit breaker.
	No input power to terminals P1 and P2	Verify wiring.
	Inaccurate generator voltmeter	Verify using a test voltmeter. Calibrate or replace a faulty meter.
	Voltage too low at terminals P1 and P2	Verify wiring.
	Low residual voltage (or reverse residual)	Flash the field per the procedure.
	Internal wire from terminal E3 is not connected to the correct tap on the sensing transformer T1	Verify wiring.
	No connection or poor connection between the exciter field and the regulator terminals F+ and F-	Connect correctly, and flash the field to restore residual.
	Poor or no connection between the exciter field and regulator terminals F+ and F	Correct the wiring, and check the connections.
	Reverse polarity between the exciter field and the regulator terminals F+ and F-	Connect correctly, and flash the field to restore residual.
	Prime mover not up to rated speed	Bring the prime mover up to rated speed.
	Open or incorrectly connected external voltage adjust rheostat	Verify wiring.
	Voltage range adjust R2 is set too low	Refer to the setting procedure.
	Shorted or opened electromagnetic interference filter	Replace the filter.
	Faulty regulator power stage (SCR1, SCR2, diodes DB1-1, DB2-1, or DB10)	Test. If it is faulty, replace the voltage regulator or power stage.
	Faulty printed circuit board	Replace the voltage regulator.
Defective rectifiers in the exciter, defective exciter windings, or defective generator	Verify operation of the exciter and/or the generator. Refer to the generator instruction manual for additional information.	
Generator output heavily loaded	Remove excessive load.	
Voltage builds up until flashing circuitry operates and then oscillates between approximately 1/3 to 2/3 rated voltage	Faulty printed circuit board	Replace the voltage regulator.

Voltage high, not controllable with voltage adjust rheostat	No voltage to terminals E1-E3	Correct wiring.
	Open sensing transformer	Correct the wiring, and check for open winding(s).
	Auto/off/manual switch is on MAN	Set to the switch to AUTO.
	External voltage adjust rheostat is shorted	Correct the wiring. Use an ohmeter to test resistance across the rheostat. Replace shorted rheostat.
	Internal wire from terminal E3 is not connected to the correct tap on the sensing transformer T1	Correct the nominal sensing voltage from the generator and wiring to transformer T1.
	Faulty regulator circuit board	Replace the voltage regulator.
	Regulator power stage SCRs or diodes are faulty	Replace the voltage regulator.
Voltage high, controllable with voltage adjust rheostat.	Internal wire from terminals E3 to the wrong tap on the sensing transformer T1	Connect the wire to the correct tap on T1.
	Improper connection of the sensing to regulator terminals E1 and E3	Correct the wiring to the voltage regulator.
	Voltage range adjust R2 set too high	Adjust R2 per the procedure.
	Generator voltmeter is inaccurate	Connect a test voltmeter to check operation of the generator output. Calibrate or replace the meter.
	Faulty SCR1 and SCR2	Replace the regulator or power stage.
	Faulty regulator circuit board	Replace the voltage regulator.
Poor regulation	Voltage at regulator terminals P1 and P2 are too low at the nominal generator voltage	Raise input voltage to 100 to 139 Vac.
	Jumper not installed across terminals CT1 and CT2 while the generator is operating singly	Install a jumper.
	Unit/parallel switch in PARALLEL during single generator operation	Switch to UNIT.
	Unit/parallel switch of the generator not on the bus set to PAR position	Set the switch of the generators not on the bus to UNIT.
	The prime mover is not up to rated speed, or the prime mover speed is fluctuating	Bring the prime mover up to rated speed and/or adjust the governor.
	Unbalanced load	Balance the load.
	Exciter field resistance is too low and/or the exciter field volts are too low	Add a series resistor. Resistance must not be less than 10 Ω . The voltage applied to the exciter field at no load must not be less than 10 Vdc. Best operation occurs when the voltage is about 20 Vdc during no-load operation. The resistor must not limit regulator output during full load operation.
	Faulty regulator circuit board	Replace the voltage regulator.
	Faulty regulator power stage diodes or SCRs	Replace the voltage regulator or the faulty components.

Poor voltage stability	Stability adjust R6 not adjusted to provide sufficient stabilizing signal.	Adjust R6 per the procedure.
	Frequency unstable.	Adjust the prime mover or the governor.
	No-load field voltage and/or resistance is too low	Add a series resistor. Resistance must not be less than 10 Ω . The voltage applied to the exciter field at no load must not be less than 10 Vdc. Best operation occurs when the voltage is about 20 Vdc during no-load operation. The resistor must not limit regulator output during full load operation.
	Voltage at regulator input power terminals P1 and P2 is too low	Raise the input voltage to 100 to 139 Vac.
	Voltage fluctuated to a point where flashing circuit energizes or de-energizes	Replace the voltage regulator.
	Faulty circuit board or regulator power stage SCRs and/or diodes	Replace the voltage regulator.
	Fault in the exciter or generator	Verify the exciter and generator operation.
Voltage recovery slow on load change.	Stability adjust R6 maladjusted	Adjust R6 per procedure.
	Slow prime mover response	Check the speed governor operation, and adjust as necessary.
	Exciter field resistance too high	Refer to the specifications given. Resistance must not limit regulator output.
	Voltage regulator capacity is less than exciter requirements	Refer to the regulator specifications. Contact Kato Engineering.
	Generator and/or prime mover are overloaded	Reduce load to rated.
Underfrequency limit (UFL) operates at too high or too low of a frequency.	Prime mover needs adjustment.	Verify governor operation, and adjust as required.
	Incorrect use of jumper J1	Correct the use of jumper J1 per procedure.
	Wrong voltage regulator	Contact Kato Engineering.
	UFL threshold adjust (R55) not adjusted correctly	Adjust R55 per procedure.

No droop compensation can be obtained for parallel generators	There is a jumper across terminals CT1 and CT2	Remove the jumper.
	Unit/parallel switch closed (set to UNIT)	Set the switch on the generator sets to PAR. Leave the switch on UNIT on any generators that will remain shutdown.
	Parallel droop adjust R1 set to minimum droop	Increase resistance across R1 by adjusting its slider.
	Parallel CT does not supply the correct secondary current.	Consult Kato Engineering (with line current and voltage). Be sure amp turns of generator line through transformer are correct.
Voltage rises instead of droops on application of inductive load	Wrong polarity between the parallel CT secondary leads and the regulator terminals CT1 and CT2	Interchange leads at terminals CT1 and CT2.
Parallel generators do not divide reactive kVAR load equally resulting in circulating reactive current between generators	Terminals CT1 and CT2 shorted by jumper or unit/parallel switch	Remove the jumper. Set the unit/parallel switch to PAR.
	Slider on droop resistor R1 set too low	Adjust for increased droop by moving the slider to a position where resistance is increased across the resistor.
	Droop resistors on generators operating parallel are set at different droop positions	Adjust R1 on all generators for identical droop per the procedure.
	Wrong parallel CT or wrong ampere turns through the CT primary	Consult Kato Engineering.
	Parallel CT is not in the correct generator line	Verify wiring.
	Parallel CT polarity is reversed	Interchange the CT secondary leads at the regulators terminals. CT1 and CT2.
Parallel generators do not evenly divide kW load	Improper setting of the governor power sensing	Adjust the governor.

Table 5: Troubleshooting