



# Systems Operation Troubleshooting Testing and Adjusting

---

## **EMCP 3**

---

CNB1-Up (Generator Set)  
ZAB1-Up (Generator Set)  
CMC1-Up (Generator Set)  
ZAD1-Up (Generator Set)  
ZAF1-Up (Generator Set)  
ZAH1-Up (Generator Set)  
ZAJ1-Up (Generator Set)  
BRK1-Up (Generator Set)  
CAL1-Up (Generator Set)  
ZAL1-Up (Generator Set)  
FDN1-Up (Generator Set)  
ZAP1-Up (Generator Set)  
PBR1-Up (Generator Set)  
ZAR1-Up (Generator Set)

---



# Table of Contents

## Systems Operation Section

General Information .....	4
Component Location .....	6
Electronic Control Module (Generator Set) .....	10
Data Link .....	12
Electronic Control Module (Engine) (EUI Engines Only) .....	13
MUI Engine Monitoring and Control .....	14
System Operation .....	14
Password Entry .....	15
Event Viewing .....	17
Event Resetting .....	18
Setpoint Programming .....	20
Digital Input Programming .....	24
Digital Output Programming .....	27
Spare Analog Input Programming .....	31
Relay Output Programming .....	31
Voltage and Frequency Adjustment .....	37
Real Time Clock Programming .....	38
Thermocouple Module .....	39
Discrete Input/Output Module .....	43
Resistive Temperature Device Module .....	45
Annunciator Module .....	48

## Troubleshooting Section

### Introduction

General Information .....	55
Service Tools .....	56
Diagnostic Capabilities .....	57
Diagnostic Trouble Code List .....	58

### Diagnostic System Procedures

Engine Cooldown Warning .....	69
Engine Overcrank Warning .....	69
Engine Speed Warning .....	70
Engine Overspeed Warning .....	71
Engine Underspeed Warning .....	73
Generator Control Not in Automatic Warning .....	76
Generator Output Sensing Circuit Fault .....	76
Generator Overcurrent Warning .....	76
Generator Overfrequency Warning .....	77
Generator Overvoltage Warning .....	80
Generator Reverse Power Warning .....	81
Generator Underfrequency Warning .....	83
Generator Undervoltage Warning .....	86
Service Maintenance Interval Warning .....	88
Analog Input Circuit Fault .....	89
Charging System .....	90
Data Link Circuit Fault .....	92
Digital Input Circuit Fault .....	93
Digital Output Circuit Fault .....	94
Engine Speed Circuit Fault .....	95
Unexpected Engine Shutdown .....	98

## Testing and Adjusting Section

### Testing and Adjusting

Electrical Connector - Inspect .....	100
Wiring Harness (Open Circuit) - Test .....	100
Wiring Harness (Short Circuit) - Test .....	101
External Potential Transformer Connections .....	101
Engine Speed Timing Calibration - Setup .....	103
Speed Sensor (Engine) - Adjust .....	103
Engine Setpoint Verification - Test .....	104
Electronic Control Module (Generator Set) - Replace .....	105
Electronic Control Module (Generator Set) - Flash Program .....	106
Electronic Control Module (Generator Set) - Configure .....	106
Typical Generator Abbreviations .....	165
ECM Connections .....	167

## Index Section

Index .....	171
-------------	-----

# Systems Operation Section

102477398

## General Information

SMCS Code: 4490

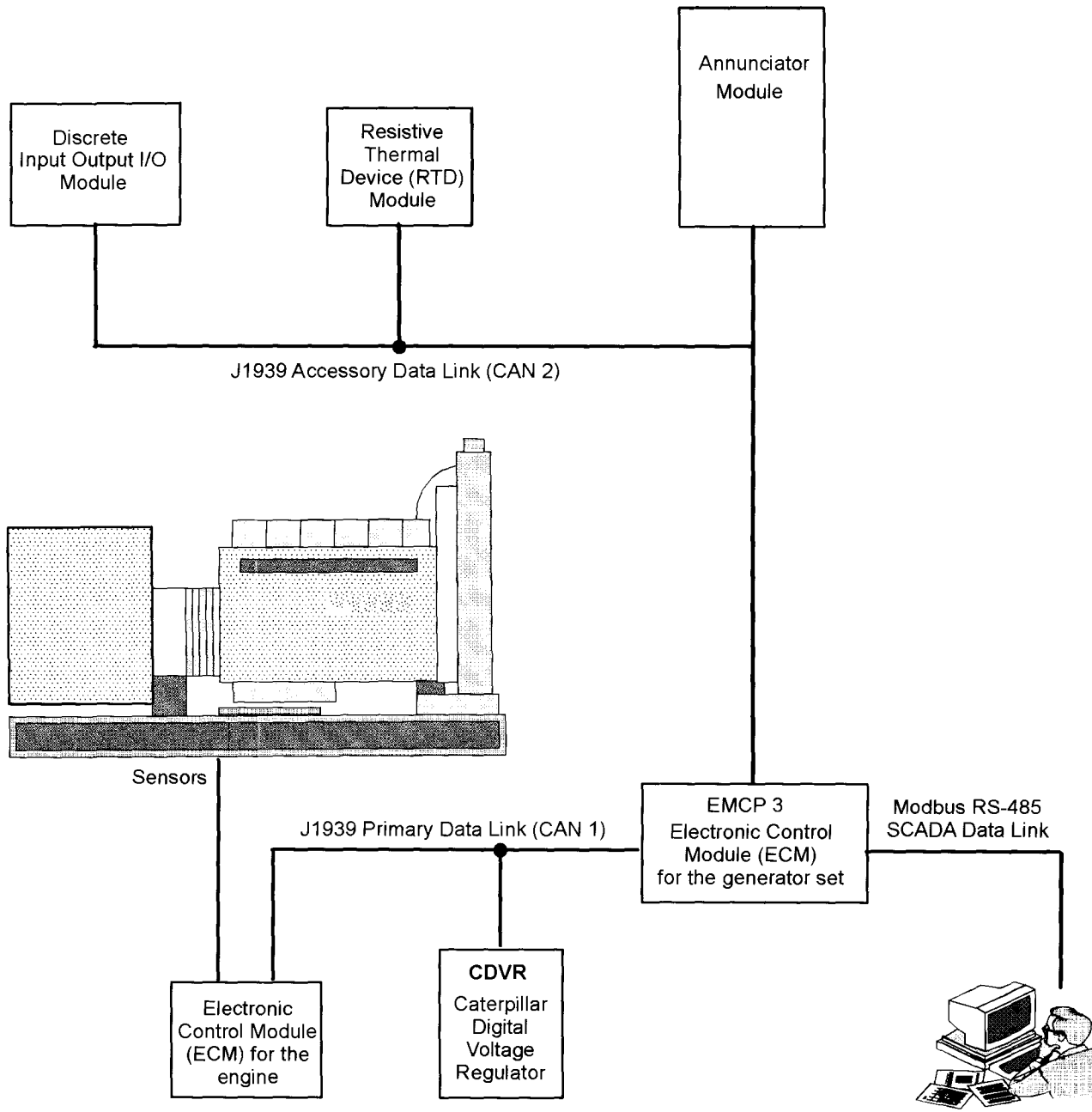

Illustration 1  
Block diagram of a generator set with EMCP 3 and EUI Engine

g01237225

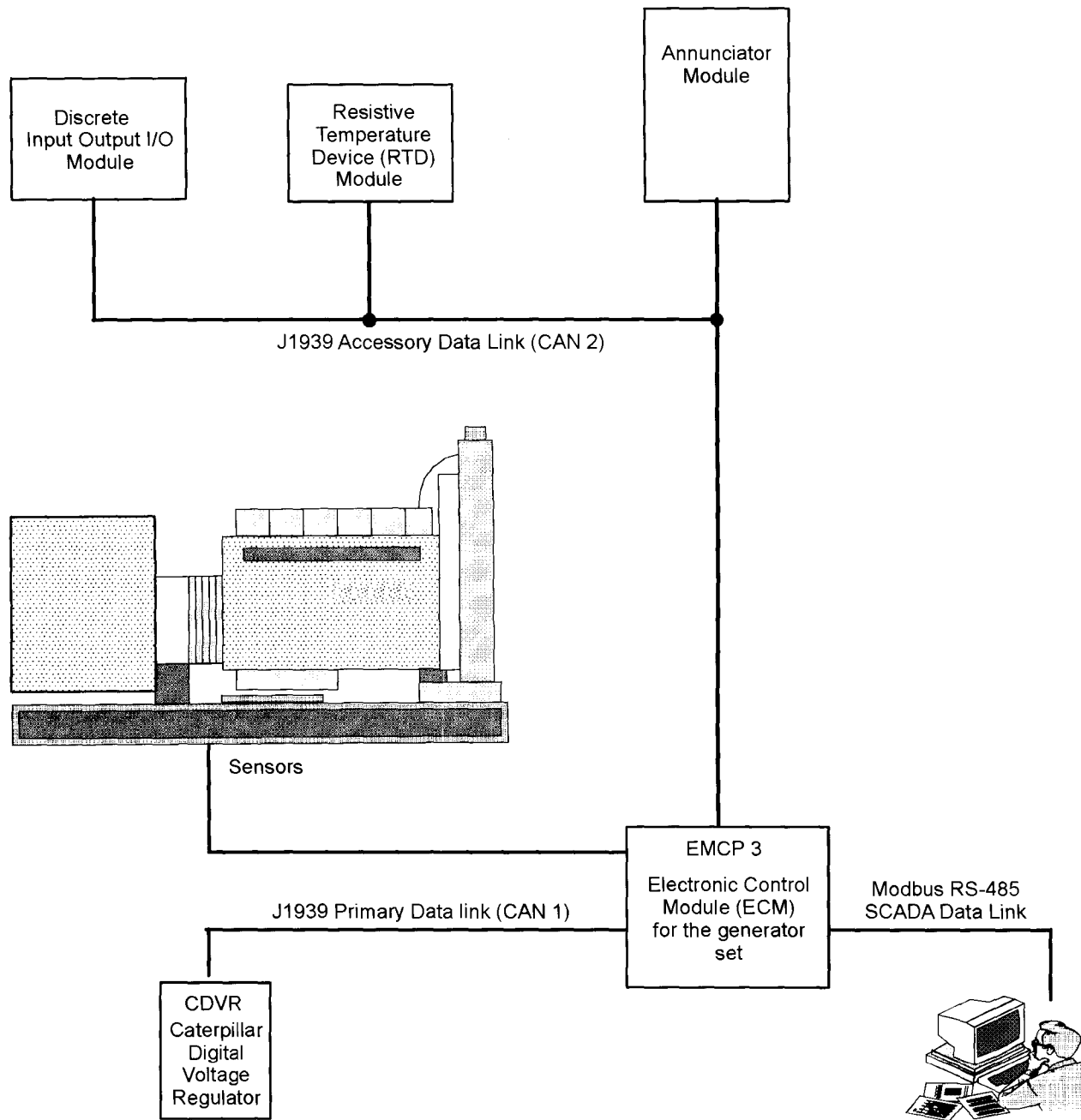

Illustration 2  
Block diagram of a generator set with EMCP 3 and MUI Engine

i02422799

## Component Location

SMCS Code: 4490

The original Electronic Modular Control Panel 3 (EMCP 3) design utilized existing hardware. These **Early Introduction Packages**, shown in Illustrations 3 and 4, are still in use today. The newest EMCP 3, shown in Illustrations 5 and 6 uses the **Global Design Package**. Both versions of the EMCP 3 have some components, such as the Start Aid Switch, that are optional. Additionally, some of the components, such as the Speed Potentiometer, are only found on certain engines. This optional and specialized information can be found in the callout section of the specific Illustration.

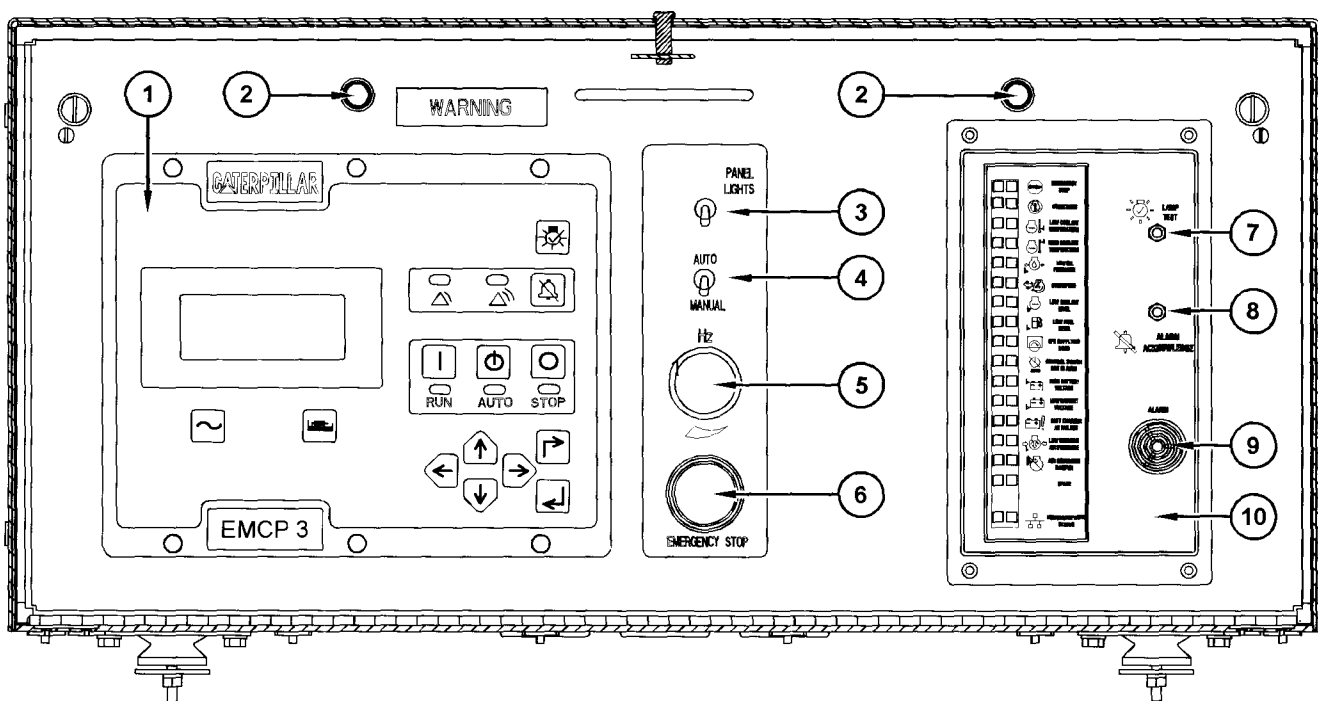

Illustration 3

g01228802

### Early Introduction EMCP 3 - Face

- |   |   |                                      |
|---|---|--------------------------------------|
| (1) Electronic Control Module (ECM) for the Generator Set | (4) Start Aid Switch (SAS) (optional)   | (8) Alarm Acknowledge/Silence Switch |
| (2) Panel Lights  | (5) Speed Potentiometer (SP) (optional) | (9) Alarm Horn                       |
| (3) Panel Light Switch (PLS)                              | (6) Emergency Stop Push Button (ESPB)   | (10) Annunciator Module (ALM)        |
|   | (7) Lamp Test Switch                    |                                      |

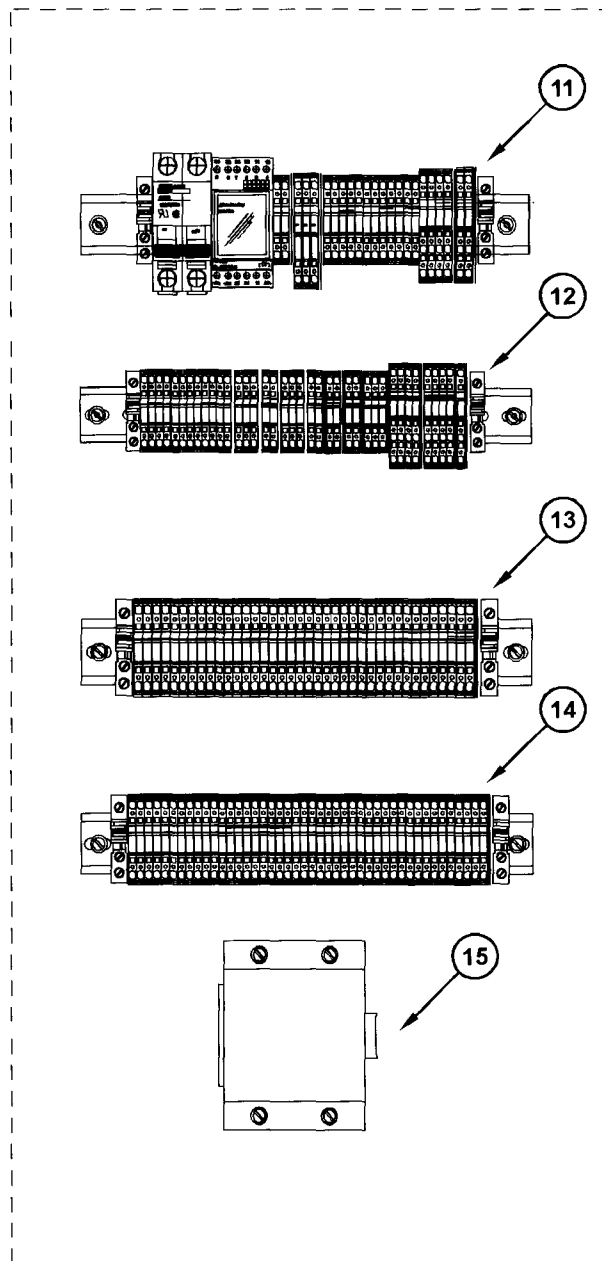

Illustration 4

Early Introduction - EMCP 3 - Subpanel

- (11) AC Terminal Strip
- (12) DC Terminal Strip
- (13) Switchgear Option Terminal Strip
- (14) Discrete Input Output (I/O) Terminal Strip

- (15) Discrete Input Output (I/O) Module or Resistive Temperature Device (RTD) Module

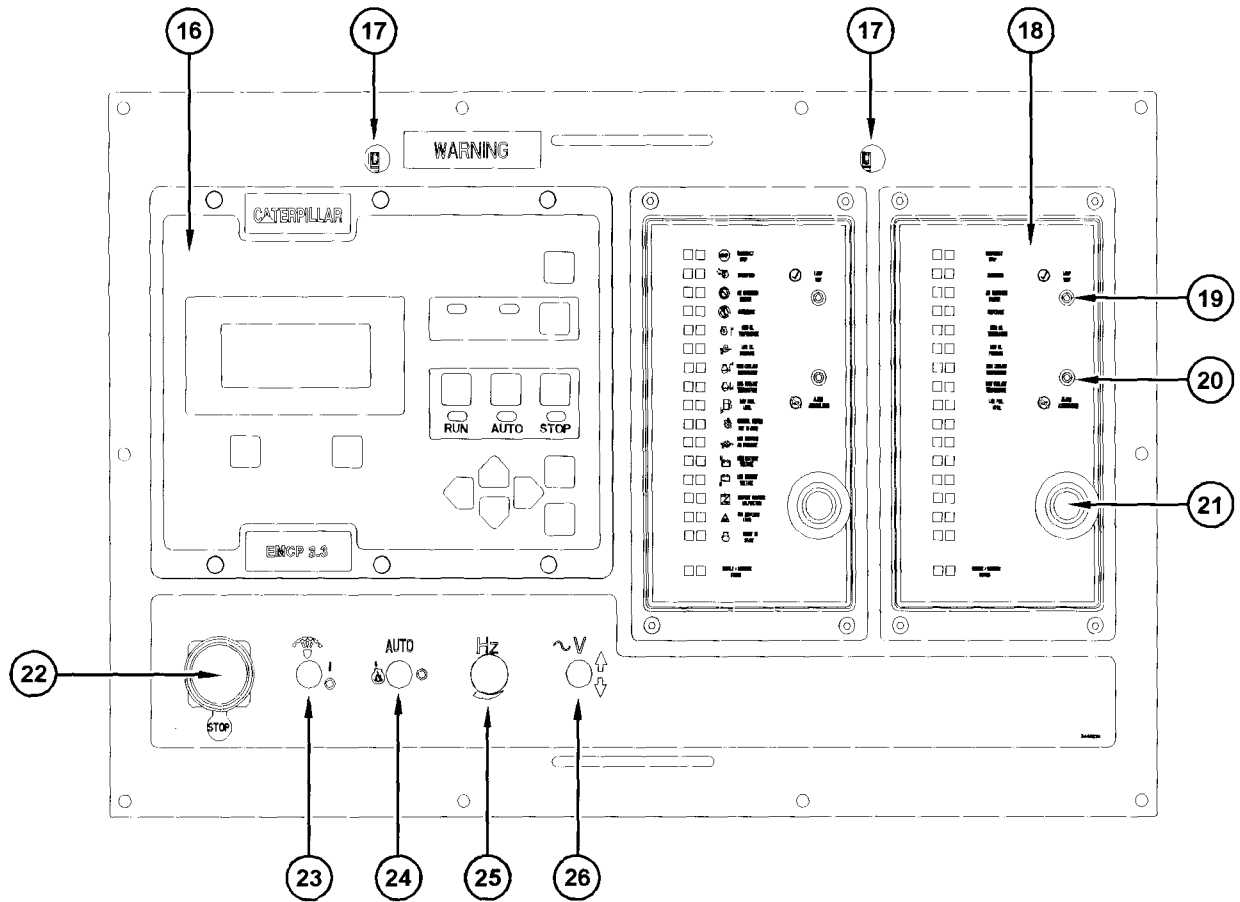

Illustration 5

g01222133

Global Design EMCP 3 - Face

- |  |   |
|--|---|
| (16) Electronic Control Module (ECM) for the Generator Set | (22) Emergency Stop Push Button (ESPB)                      |
| (17) Panel Lights (optional)                               | (23) Panel Light Switch (PLS) (optional)                    |
| (18) Annunciator Module (ALM)                              | (24) Start Aid Switch (SAS) (optional)                      |
| (19) Lamp Test Switch                                      | (25) Speed Potentiometer (SP) (optional for MUI engines)    |
| (20) Alarm Acknowledge/Silence Switch                      | (26) Voltage Adjust Toggle Switch (only on units with CDVR) |
| (21) Alarm Horn  |   |

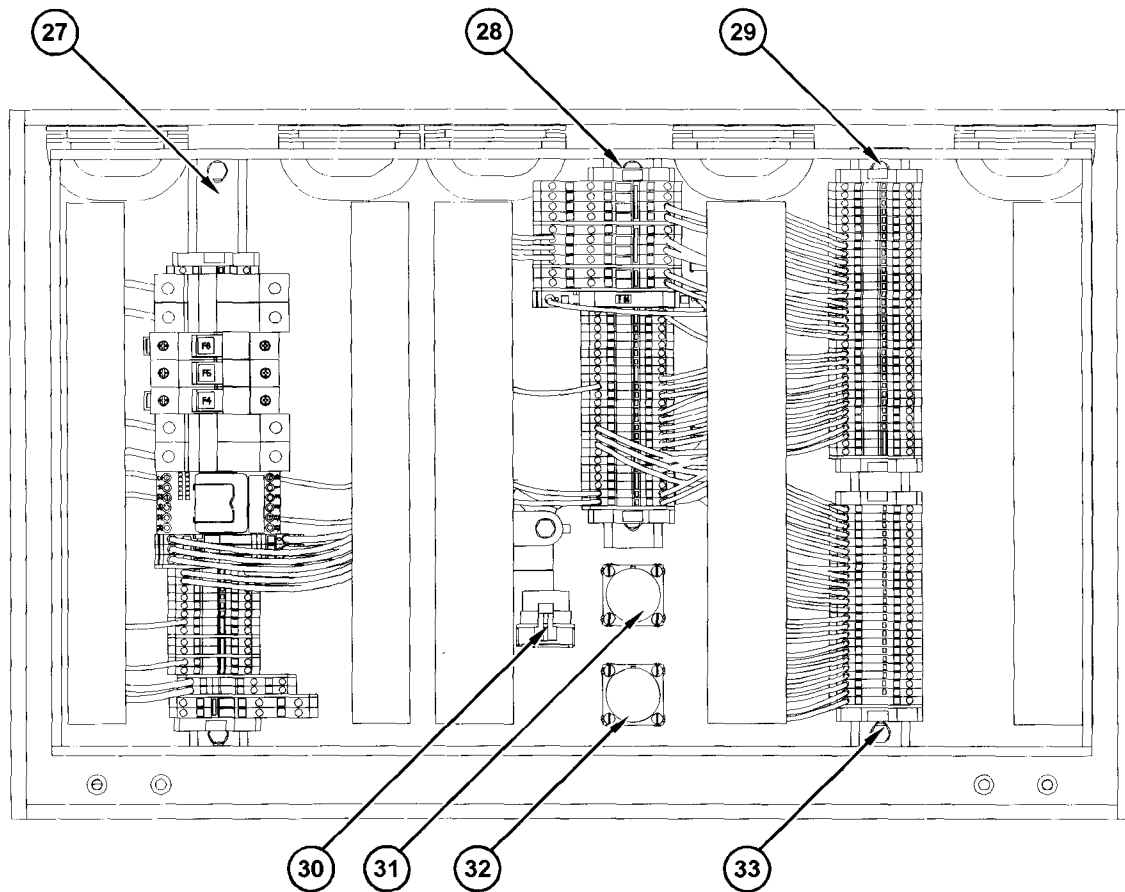

Illustration 6

g01222139

## Global Design - EMCP 3 - Subpanel

(27) AC Terminal Strip  
 (28) DC Terminal Strip  
 (29) DC Terminal Strip

(30) Relay for MUI engine with Ether Start  
 Aid option  
 (31) Service Connector for CAN 1

(32) Service Connector for CAN 2  
 (33) Discrete Input Output (I/O) Terminal  
 Strip

i02423403

# Electronic Control Module (Generator Set)

SMCS Code: 4490

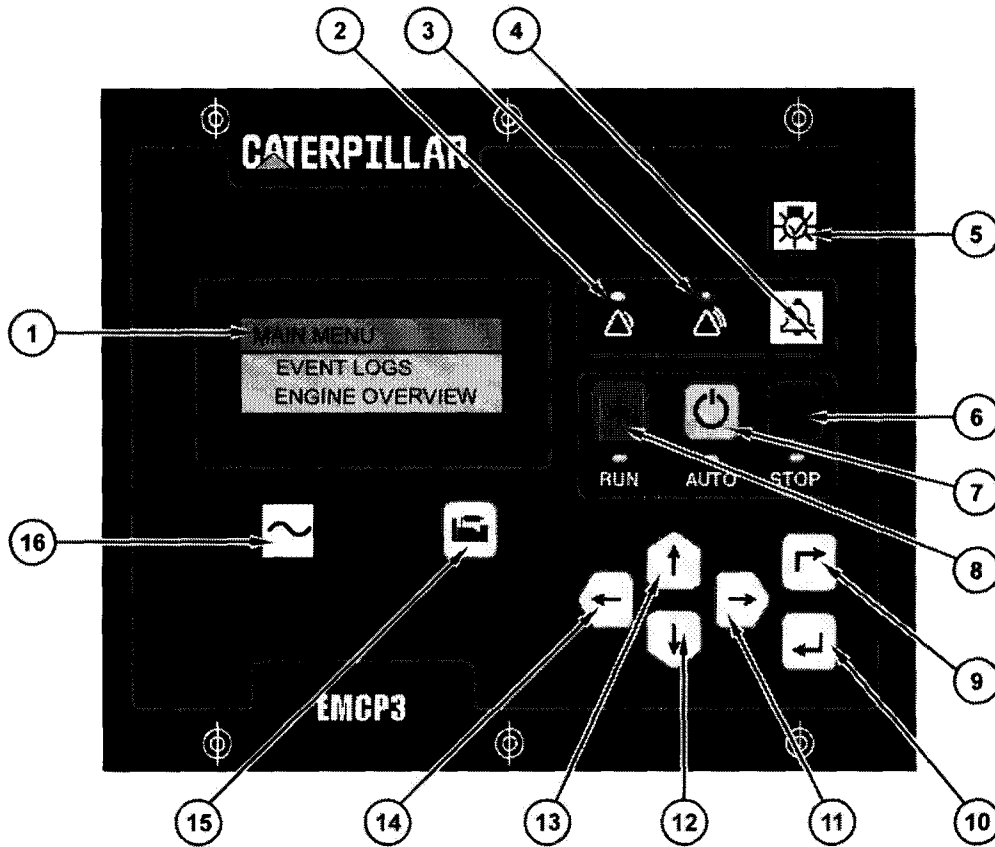

Illustration 7

g01211086

## EMCP 3 Control System Panel

- |                                   |                       |                          |
|-----------------------------------|-----------------------|--------------------------|
| (1) Display Screen                | (7) Auto key          | (13) Scroll Up key       |
| (2) Yellow Warning Lamp           | (8) Run key           | (14) Scroll Left key     |
| (3) Red Shutdown Lamp             | (9) Escape key        | (15) Engine Overview key |
| (4) Alarm Acknowledge/Silence key | (10) Enter key        | (16) AC Overview key     |
| (5) Lamp Test key                 | (11) Scroll Right key |                          |
| (6) Stop key                      | (12) Scroll Down key  |                          |

## General Information

The main component of the Electronic Modular Control Panel 3 (EMCP 3) is the Electronic Control Module (ECM). This section discusses the display, keys, and indicators on the Control System Panel of the ECM. This panel is used for monitoring and controlling many of the generator set functions. Some of the functions include:

- Sending Run, Auto, and Stop signals to the engine
- Providing visual and audible indications when warning or shutdown events occur
- Displaying Engine information and AC generator set information
- Displaying SPN and FMI information for events
- Programming setpoints for standard and optional EMCP 3 modules

## ECM Front Panel Components

The following components can be found on the front panel of the ECM:

- Information Display
- Alarm Indicators
- Alarm Acknowledge/Silence Key
- Function Keys
- Navigation Keys
- System Overview Keys

### Information Display

**(1) Display Screen** – Information from the EMCP 3 is displayed on the Display Screen. This screen is used for the following programming and display functions.

- Displaying AC parameter information of the generator set
- Displaying Engine parameter information of the generator set
- Programming setpoints for the engine/generator
- Displaying Engine Event information
- Displaying Event codes from other modules
- Programming the display preferences of the EMCP 3
- Changing password levels of the EMCP 3

### Alarm Indicators

**(2) Yellow Warning Lamp** – A solidly illuminated Yellow Warning Lamp indicates that there are acknowledged warnings that are still active. A flashing Yellow Warning Lamp indicates that there are unacknowledged active warnings. In order to verify the warnings, press the Alarm Acknowledge/Silence key (4). If there are no longer any active warnings, then the lamp will turn off. If active warnings still exist, then the lamp will change from flashing yellow to solid yellow.

**(3) Red Shutdown Lamp** – An illuminated Red Shutdown Lamp indicates that there are acknowledged shutdown events that are still active. A flashing Red Shutdown Lamp indicates that there are unacknowledged active shutdown events. In order to verify the shutdown events, press the Alarm Acknowledge/Silence key (4). If there are no longer any active shutdown events, then the lamp will turn off. If active shutdown events still exist, then the lamp will change from flashing red to solid red.

**Note:** Any condition that has caused a shutdown event must be manually reset.

**Reference:** Systems Operation, “Event Resetting”

### Alarm Acknowledge/Silence Key

**(4) Alarm Acknowledge/Silence** – Pressing the Alarm Acknowledge/Silence key causes the horn relay output to turn off, which silences the alarm. The key may also be configured in order to send out a global alarm silence that will silence horns or annunciators on the J1939 Data Link. When the horn relay sounds, one or both of the alarm lamps (2)(3) will begin to flash. Depending on the active status of the alarms when this key is pressed, the flashing lamp(s) will either turn off or solidly illuminate.

### Function Keys

**(5) Lamp Test** – Pressing and holding the Lamp Test key causes all of the LED indicators and the display screen pixels to illuminate and to remain illuminated until the key is released.

**(6) STOP** – Pressing the STOP key causes the EMCP 3 to enter the “STOP” mode.

**(7) AUTO** – Pressing the AUTO key causes the EMCP 3 to enter the “AUTO” mode.

**(8) RUN** – Pressing the RUN key causes the EMCP 3 to enter the “RUN” mode.

**(9) Escape** – The Escape key is used during menu navigation in order to navigate up through the menu/submenu structure. Each key press causes the user to move backward (upward) through the menus. The Escape key is also used in order to cancel out of data entry screens during setpoint programming. If the Escape key is pressed during setpoint programming, then none of the changes displayed on the screen will be saved to memory.

**(10) Enter** – The Enter key is used during menu navigation in order to move forward (downward) through the menu/submenu structure. The key is also used during setpoint programming in order to save setpoints changes. Pressing the Enter key during setpoint programming causes setpoint changes to be saved to memory.

## Navigation Keys

**(11) Scroll Right** – The Scroll Right key is used during setpoint adjustment. During numeric data entry, the key is used in order to choose which digit is being edited. The key is also used during certain setpoint adjustments in order to select a checkbox or to deselect a check box. If a box has a check mark inside of it, then pressing the key will cause the check mark to disappear and the function to be disabled. If the box does not have a check mark inside of it, then pressing the key will cause a check mark to appear inside the box and the function will be enabled.

**(12) Scroll Down** – The Scroll Down key is used in order to navigate down through the various menus or monitoring screens. The key is also used during setpoint entry. During numeric data entry, the key is used in order to decrement the digits (0-9). If the setpoint requires selection from a list, then the key is used to navigate down through the list.

**(13) Scroll Up** – The Scroll Up key is used in order to navigate up through the various menus or monitoring screens. The key is also used during setpoint entry. During numeric data entry, the key is used in order to increment the digits (0-9). If the setpoint requires selection from a list, then the key is used to navigate up through the list.

**(14) Scroll Left** – The Scroll Right key is used during setpoint adjustment. During numeric data entry, the key is used in order to choose which digit is being edited. The key is also used during certain setpoint adjustments in order to select a checkbox or to deselect a check box. If a box has a check mark inside of it, then pressing the key will cause the check mark to disappear and the function to be disabled. If the box does not have a check mark inside of it, then pressing the key will cause a check mark to appear inside the box and the function will be enabled.

## System Overview Keys

**(15) Engine Overview** – Pressing the Engine Overview key displays the first screen of engine information. This initial information page contains various engine parameters that summarize the operation of the engine. Additional engine parameters can be viewed by pressing the Scroll Down key (12) multiple times.

**(16) AC Overview** – Pressing the AC Overview key displays the first screen of AC information for the generator set. This initial information page contains various AC parameters that summarize the electrical operation of the generator set. Additional AC parameters can be viewed by pressing the Scroll Down key (12) multiple times.

## Data Link

**SMCS Code:** 4490

## Data Links

The EMCP 3 has up to three different data links:

- Primary Data Link
- Accessory Data Link
- System Control And Data Acquisition (SCADA) Data Link

**Note:** The “EMCP 3.1” has one Primary Data Link. The “EMCP 3.2” and “EMCP 3.3” have one Primary Data Link, one Accessory Data Link, and one SCADA Data Link.

### Primary Data Link - J1939 (CAN 1)

The Primary Data Link is used for local communication among modules associated with a single genset such as the Electronic Control Module (ECM) for the engine (EUI engines only), Caterpillar Digital Voltage Regulator (CDVR), and the Thermocouple Module. On MUI engines, the engine sensors are wired directly to the EMCP 3. The Primary Data Link utilizes the Society Of Automotive Engineers (SAE) J1939 protocol and requires Controller Area Network (CAN) hardware running at 250k bits per second.

The Primary Data Link supports appropriate SAE J1939 Broadcast Parameter Group Numbers (PGN) and Suspect Parameter Numbers (SPN) for engine and genset data.

### Accessory Data Link - J1939 (CAN 2)

The Accessory Data Link is used for local communication among modules associated with a single genset such as Annunciators, RTD Modules and Discrete Input Output Modules. It utilizes the Society Of Automotive Engineers (SAE) J1939 protocol and requires CAN hardware running at 250k bits per second.

The Accessory Data Link supports appropriate SAE J1939 Broadcast Parameter Group Numbers (PGN) and Suspect Parameter Numbers (SPN) for engine and genset data.

### SCADA Data Link - Modbus RS-485

The SCADA Data Link is used for communication with a System Control And Data Acquisition (SCADA) system, and for support of a service tool connection.

The SCADA Data Link uses the Modbus Protocol with an RS-485 half duplex hardware layer operating at a minimum of 2.4k bits per second. All data items are accessed as Modbus registers. Data that is less than 16 bits occupies a single register. Larger data occupies consecutive registers in order to allow access using single request.

The SCADA Data Link is a Master/Slave Data Link. The SCADA controller Service Tool or customer software will be the master and the genset controls will be slaves on the Data Link.

The SCADA controller can connect directly to the genset control or it may be connected remotely through a modem using an RS-485 to RS-232 converter. Passwords levels are used in order to restrict access to the genset control.

Each genset control on the SCADA Data Link has a unique Modbus Address. A setpoint is available to select the address for the genset control.

In order to use a modem connection to the SCADA Data Link, the modem must be pre-configured with all necessary communication parameters and set to automatically answer. No modem handshaking or control is performed by the genset controls.

i02449491

## Electronic Control Module (Engine) (EUI Engines Only)

**SMCS Code:** 1901

The Electronic Control Module (ECM) for the engine controls all aspects of starting and stopping the engine. Recently produced EUI engines utilize a Common Engine Interface. In a Common Engine Interface applications the EMCP 3 only sends the engine start and the engine stop information across the datalink.

**Note:** For a Common Engine Interface application, the cooldown timer in the ECMP 3 should be set to zero.

The Engine ECM controls engine speed and also enables fuel injection on EUI engines in electric power generation applications. Both the fuel enable input and the speed input are configurable using the service tool.

The fuel enable input to the ECM can be a switch-to-ground or the input can be transmitted over the primary J1939 data link from the EMCP 3.

The desired engine speed is derived from one of the two following inputs:

- Input from a converter that converts the analog speed signal of a speed potentiometer into a pulse width modulated signal or directly from EMCP 3 over the Primary J1939 Data Link
- The ECM uses feedback from the engine speed sensors that are mounted on the engine to control the engine speed

There are primary and secondary speed inputs. The speed inputs can be a pulse width modulated signal or the speed inputs can be transmitted over the primary J1939 link (CAN 1).

**Note:** The Caterpillar service tool is used in order to configure the speed inputs as either primary or as secondary.

If the primary speed input fails, then the engine ECM will generate a diagnostic, acknowledge the failure, and respond to the secondary input. If the primary speed input fails and the secondary input is disabled, then the engine will default to the idle speed setting.

The EMCP 3 receives specific information that it uses in order to monitor the system for events. If a particular parameter is not supported by the engine ECM, then the EMCP 3.3 displays the parameter name with an associated value of "\*\*\*\*\*", which indicates that there is no value associated with that specific parameter.

**Note:** Recent versions of software do not display the parameter name for unsupported parameters.

The information that is shown on the display screen of the EMCP 3.3 is:

- Engine Oil Pressure (see note)
- Engine Coolant Temperature (see note)
- Left Exhaust Manifold Temperature
- Right Exhaust Manifold Temperature
- Intake Manifold Temperature
- Oil Temperature
- Fuel Pressure
- Boost Pressure
- Oil Filter Differential Pressure
- Fuel Filter Differential Pressure
- Air Filter Differential Pressure
- Fuel Consumption

**Note:** Engine information displayed on the EMCP 3.1 and EMCP 3.2 includes only "Engine Oil Pressure" and "Engine Coolant Temperature".

The EMCP 3 also displays diagnostic codes from the ECM as a convenience to the operator.

**Reference:** For information on the management of diagnostic codes by the EMCP 3 and the ECM, see Troubleshooting, "Diagnostic Trouble Code List".

**Reference:** For EMCP 3 settings that are specific to EUI engine applications, see Testing and Adjusting, "Electronic Control Module (Generator Set) - Configure", Setpoint Tables.

i02463214

## MUI Engine Monitoring and Control

**SMCS Code:** 4490

The EMCP 3 can be used for monitoring and control of MUI engines. With the absence of an engine ECM, the EMCP 3 uses relay outputs to control start/stop and uses analog resistive sender inputs for monitoring of critical engine parameters.

**Reference:** For EMCP 3 configuration settings that are specific to MUI engine applications, see Testing and Adjusting, "Electronic Control Module (Generator Set) - Configure", Setpoint Tables.

MUI engine start/stop control by EMCP 3

- Relay output #1 (non configurable) to energize starter motor magnetic switch used to crank the engine
- Relay output #2 (non configurable) gives run signal to engine governor
- Additional relay output (configured for "rated speed") gives permissive signal to engine governor to ramp up to rated speed

MUI engine parameters monitored directly by EMCP 3:

- Engine speed (via MPU input)
- Oil pressure (via analog input #1)
- Coolant temperature (via analog input #2)
- Spare input (EMCP 3.3 only)

**Note:** MUI engines use different sensors for the parameters that are specified above. As a result, EMCP 3 applications on MUI engines require different firmware than that used on EUI engines.

**Reference:** Testing and Adjusting, "Electronic Control Module (Generator Set) – Flash Program"

i02449781

## System Operation

**SMCS Code:** 4490

Before putting the engine into service, verify the following:

- The desired voltage and frequency are correct at rated engine speed
- Load control devices are functioning properly and have the load isolated from the generator when not running
- If warning events are present, i.e. the yellow warning lamp (2) is lit, then take corrective action if necessary
- No shutdown events are active, i.e. the red shutdown lamp (3) is not lit
- For remote initiate operation, the EMCP 3 must be in AUTO mode

### Engine Starting Sequence

1. The EMCP 3 receives an engine start signal under one of the three following conditions
  - The operator presses the "RUN" key
  - The control is in "AUTO" and the remote initiate input (IC) becomes active
  - The operator presses the "AUTO" key and a start command is sent via the RS-485 SCADA Data Link (Modbus).
2. The EMCP 3 checks the following system items before beginning the cranking sequence:
  - There are no system faults present
  - All previous shutdowns have been reset
  - The engine is not running
  - The prelube status (if the engine is so equipped) shows complete

3. The EMCP 3 begins the starting sequence.
  - a. On MUI engines, the EMCP 3 activates the starting motor relay (relay output #1) and the fuel control relay (relay output #2).
  - b. On EUI engines that do not utilize a common engine interface, the EMCP 3 activates the starting motor relay (SMR) and sends a start signal to the Engine ECM via the J1939 Primary Data Link.
  - c. On EUI engines that utilize a common engine interface, the EMCP 3 will send a start signal to the engine ECM via the J1939 data link and the ECM will be responsible for cranking the engine (4) and deactivating the starting motor relay (5).
4. The EMCP 3 cranks the engine for the programmed crank time or until the engine starts. If the engine does not start after the crank time has elapsed, then the starting motor relay will de-energize for the programmed rest time. After the rest time has elapsed, then the starting motor relay will start cranking again for the programmed crank time.
 

A cycle consists of a crank time and a rest time. If the engine has not started after the programmed number of cycles, then the EMCP 3 will abort the starting process and will generate an "Engine Failure to Start Shutdown".
5. The EMCP 3 deactivates the starting motor relay when the engine speed reaches the setpoint for the crank terminate speed.

### Engine Stopping Procedure

1. The EMCP 3 will receive an engine stop signal under one of the three following conditions:
  - The operator presses the "STOP" key.
  - The control is in "AUTO" and the remote initiate input (IC) becomes inactive.
  - The control is in "AUTO" and a stop command is sent via the Modbus data link.

**Note:** If the control is in "AUTO", then in order for the engine to shut down, the remote initiate must be inactive AND the modbus data link must be requesting a stop. If either the remote initiate or the Modbus is requesting an engine run state, then the engine will not shut down.

2. After receiving the Stop signal, the EMCP 3 checks that there are no system faults present.

3. The EMCP 3 begins the cooldown period. In order to bypass the cooldown, depress and hold the "STOP" key. The screen displays instructions to "PRESS ENTER TO BYPASS", and "PRESS ESCAPE TO CONTINUE" Press the **Enter** key in order to bypass the cooldown sequence or press the **Escape** key in order to continue the cooldown sequence.

**Note:** For common engine interface applications, cooldown should be set to zero.

4. After the cooldown cycle, the EMCP 3 initiates an engine shutdown by turning off the fuel supply.
  - a. On the MUI engines, the EMCP 3 deactivates the fuel control relay, which in turn, shuts the engine down.
  - b. On EUI engines, the EMCP 3 sends a shutdown signal to the Engine ECM over the primary J1939 data link in order to shut down the engine.

i02449875

## Password Entry

**SMCS Code:** 4490

There are three levels of password protection on the EMCP 3 control panel. All of the adjustable parameters are associated with a specific level of security that is required in order to make an adjustment to the parameter.

The passwords only affect changing parameters from the EMCP 3 control panel. Changing parameters with the Caterpillar service tool does not require passwords.

The level of password protection that is required for each setpoint is identified on the parameter setpoint entry screen. A security level identification number "1", "2", or "3" next to a padlock symbol is displayed on the parameter setpoint entry screen. Level 3 security is used for the most secure setpoints and Level 1 security is used for the least secure setpoints.

If the EMCP 3 is currently at the required level of protection when viewing a parameter, then the padlock will not appear.

If a parameter is displayed with a padlock, but there is no security level identification number associated with it, then the parameter cannot be changed from the EMCP 3 display.

Level 1 and Level 2 passwords are disabled when shipped from the factory. If desired, Level 1 and Level 2 passwords can be user defined on initial startup of the EMCP 3.

## Function and Navigation Keys

**Reference:** Callouts in this section can be found on the EMCP 3 Control System Panel in Systems Operation, "Electronic Control Module (Generator Set)"

The keys listed below are used for programming the EMCP 3 and navigating within the menu structure.

**Reference:** For a full explanation of the use of the Function keys (Enter, Escape) and the Navigation keys (Scroll Left, Scroll Right, Scroll Up, Scroll Down) that are referenced in this section, see Systems Operation, "Electronic Control Module (Generator Set)"

**(9) Escape** – Navigate up (backward) through the menu structure and also used to cancel out of data entry screens during setpoint programming.

**(10) Enter key** – Select a highlighted menu item or save a programmed value.

**(11) Scroll Right key** – During numeric data entry, choose the digit to edit. During certain setpoint adjustments, select or deselect a checkbox.

**(12) Scroll Down key** – Move down through the main menu or navigate within a list in order to highlight one of the items. Also used to decrement digits (0-9).

**(13) Scroll Up key** – Move up through the main menu or navigate within a list in order to highlight one of the items. Also used to increment digits (0-9).

**(14) Scroll Left key** – During numeric data entry, choose the digit to edit. During certain setpoint adjustments, select or deselect a checkbox.

## Drop to Minimum Security Level

The first option on the security screen is "DROP TO MIN LEVEL". This option refers to a process of placing the EMCP 3 into the lowest level of security that is authorized. This would be used after the programming of the control is complete. If "DROP TO MIN LEVEL" is not initiated manually, then the control will automatically revert to the minimum level after ten minutes of non-activity.

1. From the MAIN MENU, press the **Scroll Up** key or the **Scroll Down** key in order to highlight the CONFIGURE menu.

2. Press the **ENTER** key in order to select the CONFIGURE menu. SECURITY will be highlighted.

3. Press the **ENTER** key in order to select the SECURITY. The DROP TO MIN LEVEL option will be highlighted.

4. Press the **ENTER** key in order to select the DROP TO MIN LEVEL option

5. The EMCP 3 will now be at the minimum level of security

**Note:** When the EMCP 3 is in the SECURITY screen, then the current level of security for the EMCP 3 is displayed at the top of the display.

## Enter Level 1 or 2 Password

1. From the MAIN MENU, press the **Scroll Up** key or the **Scroll Down** key in order to highlight the CONFIGURE menu.

2. Press the **Enter** key in order to select the CONFIGURE menu. SECURITY will be highlighted.

3. Press the **Enter** key in order to select the SECURITY menu. "DROP TO MIN LEVEL" will be highlighted.

4. Press the **Scroll Down** key in order to highlight ENTER LEVEL 1 OR 2.

5. Press the **Enter** key in order to select the ENTER LEVEL 1 or 2 menu. "ENTER PASSWORD FOR DESIRED LEVEL" is displayed. There is also a 16 digit entry field with 0 highlighted at the far right.

6. Press the **Scroll Up** key or the **Scroll Down** key in order to increment or decrement the highlighted digit to the desired number.

7. Press the **Scroll Left** key in order to highlight the next character to be entered and then press the **Scroll Up** key or the **Scroll Down** key in order to increment or decrement the highlighted digit to the desired number.

8. Continue this process until the correct password has been entered for the corresponding level. When all digits of the password are correctly entered, then press the **Enter** key. This action will display the current level of password protection and the parameters can now be set.

**Note:** The EMCP 3 will go to the highest level of security authorized by a correctly entered password.

**Note:** Level 1 and Level 2 passwords are entirely determined by the user and can range from one to sixteen digits

**Note:** If parameters are being changed using a Caterpillar service tool, then a password is not required.

### Enter level 3 password

1. From the MAIN MENU, press the **Scroll Up** key or the **Scroll Down** key in order to highlight CONFIGURE.
2. Press the **Enter** key in order to select the CONFIGURE menu. "SECURITY" will be highlighted.
3. Press the **Enter** key in order to select SECURITY. DROP TO MIN LEVEL will be displayed.
4. Press the **Scroll Down** key in order to highlight ENTER LEVEL 3. Press the **Enter** key in order to select ENTER LEVEL 3.
5. A sixteen digit number is displayed and ENTER RESPONSE is highlighted. Copy the displayed number and call the Dealer Solutions Network (DSN) in order to obtain a factory provided response code to enter into the EMCP 3.
6. When the factory response is received from the factory, press the **Enter** key in order to select ENTER RESPONSE. ENTER RESPONSE is displayed, along with a sixteen digit entry field where the factory provided password will be entered.
7. Use the **Scroll Up** key or the **Scroll Down** key in order to increment or to decrement the highlighted digit to the corresponding digit of the factory provided password.
8. Press the **Scroll Right** key or the **Scroll Left** key in order to highlight the next character that is to be entered, and use the **Scroll Up** or the **Scroll Down** key in order to increment or decrement the highlighted digit to the corresponding digit of the DSN provided password.
9. Continue this process until all sixteen digits of the password are entered, and then press the **Enter** key. After this action, the current level (LEVEL 3) of security is displayed and parameters can be set.

**Note:** If parameters are being changed using a Caterpillar service tool, then a password is not required.

### Change level 1 or level 2 password

1. From the MAIN MENU, press the **Scroll Up** key or the **Scroll Down** key in order to highlight the CONFIGURE menu.

2. Press the **Enter** key in order to select CONFIGURE. SECURITY will be highlighted.
3. Press the **Enter** key in order to select SECURITY. DROP TO MIN LEVEL will be highlighted
4. Ensure that the current level of security is at least as high as the level of the password that is to be changed.
5. Press the **Scroll Down** key in order to highlight CHANGE LEVEL 1 PSWD. Press the **Enter** key in order to select CHANGE LEVEL 1 PSWD. CHANGE LEVEL 1 PSWD is displayed along with a sixteen digit password entry field that has a zero highlighted in far right of the field.
6. . Press the **Scroll Up** key or the **Scroll Down** key in order to increment or to decrement the highlighted digit to the corresponding number of the desired password.
7. Press the **Scroll Left** key in order to highlight the next character that is to be entered. Press the **Scroll Up** key or the **Scroll Down** key in order to increment or to decrement the highlighted digit to the corresponding number of the desired number.
8. Continue this process until the desired password is displayed and then press the **Enter** key. The password is now set.

**Note:** In order to change a level 2 password, substitute "CHANGE LEVEL 2 PSWD" for "CHANGE LEVEL 1 PSWD" in step 5 above.

**Note:** Level 1 and Level 2 passwords are entirely determined by the user and can range from one to sixteen digits

**Note:** To disable a password, set the password to a single zero.

i02449952

## Event Viewing

**SMCS Code:** 4490

**Reference:** Callouts in this section can be found on the EMCP 3 Control System Panel Illustration in Systems Operation, "Electronic Control Module (Generator Set)"

Event system information from the EMCP 3 is displayed on the display screen (1). The event system uses the following terms to describe the status of an event:

**PRESENT** – The condition causing the event is present and is affecting the system behavior.

**Note:** For optional modules such as Thermocouple, RTD, and Discrete I/O, there will be only Active and Inactive events. There are no Present events for optional modules.

**ACTIVE** – The event was previously in a Present state, but it is no longer present. It has been latched by the event system and needs to be reset before the engine can be restarted.

**INACTIVE** – The event was previously in an Active or a Present state, but it is no longer in an Active or a Present state, and it is not affecting system behavior.

The ACTIVE EVENTS menu is used to display Active events for ECMs, including those ECMs that are connected to the EMCP 3 over the data link.

There is a number in the top right of the ACTIVE EVENTS menu that indicates how many Active or Present events are currently in the system. There is also a number to the right of each listed ECM that indicates how many Active or Present events are currently associated with that particular ECM.

The ECMs listed in Table 1 can have an event log associated with them:

Table 1

ECM	Event Type
Genset Control	EMCP 3
Engine Control	ADEM
AVR (requires CDVR	Voltage Regulator
Thermocouple (TC) Module	Optional TC
Resistive Temperature Device (RTD) Module	Optional RTD
Discrete Input/Output (DI/O) Module	Optional DI/O

**Note:** On power up, the EMCP 3 displays the MAIN MENU screen. If the EMCP 3 is currently powered up, and the MAIN MENU screen is not displayed, then press the **Escape** key (9) as many times as required in order to return to the MAIN MENU. Each successive press of the **Escape** key backs you up one level in the menu structure.

Perform the following steps in order to view an event.

- Using the **Scroll Down** key (12) or the **Scroll Up** key (13), navigate within the MAIN MENU to the EVENT LOGS menu and press the **Enter** key . The ACTIVE EVENTS menu is displayed listing the connected ECM.

**Note:** Events are organized by which ECM originated the event.

- Select an ECM and press the **Enter** key (10). All of the Events associated with the ECM are displayed.
- In order to scroll through the Events, use the **Scroll Up** key (11) and the **Scroll Down** key (12).
- After highlighting an event, press the **Enter** key (10) in order to see information about the event such as the SPN and the FMI.

Press the **Scroll Down** key (12) in order to see additional information such as the following:

- Time and date of first occurrence
- Time and date of last occurrence
- Engine hours at first occurrence
- Engine hours at last occurrence

i02451107

## Event Resetting

**SMCS Code:** 4490

**Reference:** Callouts in this section can be found on the EMCP 3 Control System Panel Illustration in Systems Operation, "Electronic Control Module (Generator Set)"

A flashing Red Shutdown Lamp (3) indicates that there is an unacknowledged shutdown event. The lamp will change from flashing red to solid red when the **Alarm Acknowledge** key (4) is pressed.

Only Shutdown events can be reset. These events are described as "Active". Use the following procedure in order to reset these active shutdown events.

- Press the **STOP** key (6).

**Note:** The control must be in "STOP" in order to reset active shutdown events.

- Using the **Scroll Down** key (12), navigate from the MAIN MENU to the EVENT LOGS menu and press the **Enter** key (10). An ACTIVE EVENTS menu is displayed listing the ECMs. The total number of active events for an ECM is listed to the right of the ECM.
- Using the **Scroll Down** key, highlight an ECM with active events, and then press the **Enter** key in order to display the active events for the selected ECM.

**Note:** Events are sorted from top to bottom such that highest priority events will be at the top of the event log.

The event states, priority level, and event types that can be associated with a specific event state are listed in Table 2

Table 2

Event State	Priority Level	Event Type
Present <sup>(1)</sup>	Highest	Warnings Shutdowns
Active	Medium	Shutdowns
Inactive	Lowest	Warnings Shutdowns

<sup>(1)</sup> Does not apply to optional modules

4. Scroll through the events in order to highlight an active event.
5. Ensure that the condition which caused the event is no longer present and then press the **Enter** key .

If the condition that caused the event is no longer present, and the control is in "STOP", then either RESET or RESET ALL will be highlighted .

6. Press the **Enter** key again. The fault will clear. If there are no other active shutdown events, then the Red Shutdown Lamp will be turned off.
7. Repeat steps 3 through 6 until there are no active shutdown events remaining. When all active shutdown events have been reset, then the Red Shutdown Lamp will be turned off.
8. Press the **Escape** key (9) three times in order to return to the MAIN MENU screen.

i02451162

## Setpoint Programming

SMCS Code: 4490

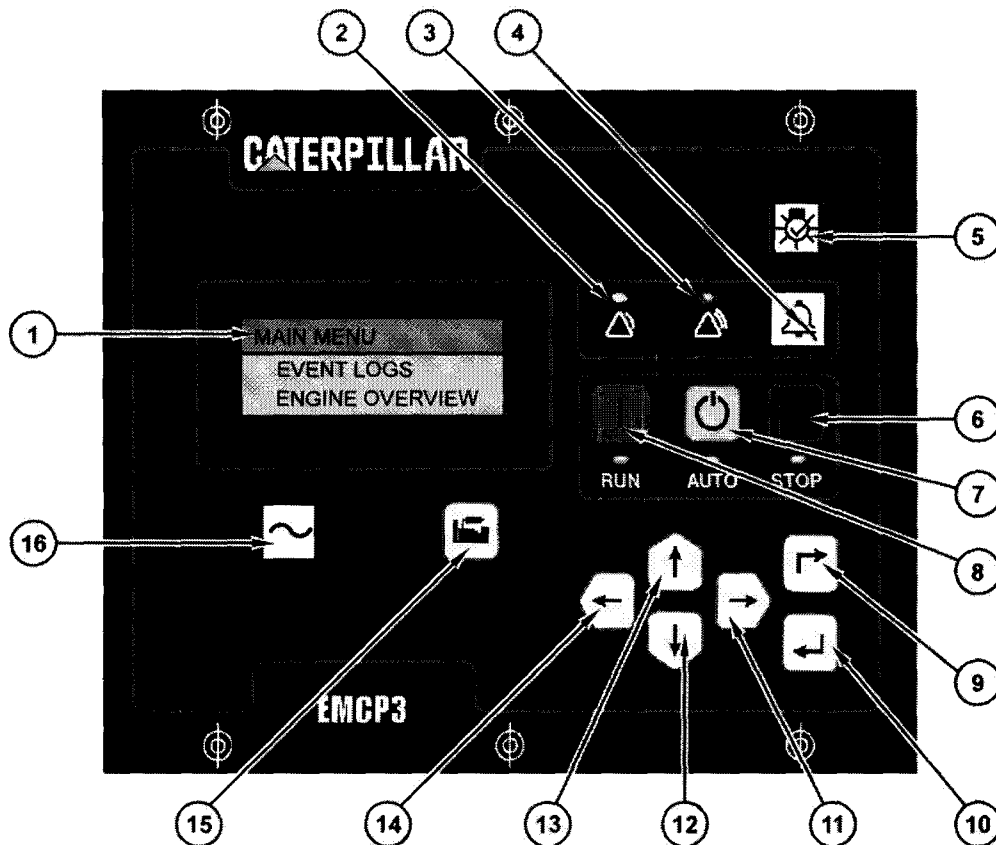

Illustration 8

g01233459

The engine and generator setpoints are programmed in the EMCP 3 at the factory. The setpoints that are stored in the EMCP 3 must match the specified setpoints of the particular generator set. These setpoints, which are programmable, affect the proper operation and serviceability of the engine, as well as the accuracy of the information that is shown on the **Display Screen** (1).

The setpoints may require modification when the EMCP 3 is moved from one engine to another engine. The setpoints may also require modification in order to satisfy the requirements of the installation.

### Function and Navigation Keys

The keys listed below are used for programming the EMCP 3 and navigating within the menu structure.

**Reference:** For a full explanation of the use of the Function keys (Enter, Escape) and the Navigation keys (Scroll Left, Scroll Right, Scroll Up, Scroll Down) that are referenced in this section, see Systems Operation, "Electronic Control Module (Generator Set)"

**(9) Escape** – Navigate up (backward) through the menu structure and also used to cancel out of data entry screens during setpoint programming.

**(10) Enter key** – Select a highlighted menu item or save a programmed value.

**(11) Scroll Right key** – During numeric data entry, choose the digit to edit. During certain setpoint adjustments, select or deselect a checkbox.

**(12) Scroll Down key** – Move down through the main menu or navigate within a list in order to highlight one of the items. Also used to decrement digits (0-9).

**(13) Scroll Up key** – Move up through the main menu or navigate within a list in order to highlight one of the items. Also used to increment digits (0-9).

**(14) Scroll Left key** – During numeric data entry, choose the digit to edit. During certain setpoint adjustments, select or deselect a checkbox.

### EMCP 3.x Programming Example

**Note:** This programming example is not intended as a standard or as a preferred method of use. It is presented here only as an example of the logical flow for programming.

For consistency of terminology, a “normally closed” switch is a switch that is closed prior to installation, (not being acted upon). A “normally open” switch is a switch that is open prior to installation, (not being acted upon). This example outlines the steps for wiring a low fuel level shutdown float switch to digital input #3.

In this example, the “Active Low” configuration will be used assuming a normally open switch that closes when the fuel level drops to the low shutdown level, which in turn shuts off the generator set.

1. Mount the switch in the desired location and then route and connect the wiring.
  - a. Route a wire to the 70 pin connector on pin #54. This wire is for digital input #3.
  - b. Route a second wire to a battery negative point in the system.
  - c. Connect the two wires to the contacts of the newly mounted switch.
2. Select the appropriate digital input and the Active state for the mounted switch.
  - a. Navigate to the DIGITAL INPUTS menu as follows:

```

MAIN MENU
.... CONFIGURE
..... SETPOINTS
..... I/O
..... DIGITAL INPUTS

```

- b. Press the **Enter** key. The available digital inputs are displayed.
- c. Scroll through the available Digital inputs until Digital Input #3 is highlighted, and then press the **Enter** key
- d. Press the **Enter** key a second time. This action highlights the current configuration of the Active state for Digital Input #3.
- e. Set the Active state to the LOW option using the **Scroll Up** and the **Scroll Down** keys, and then press the **Enter** key in order to save the selection.

**Note:** The selection of HIGH or LOW for the Active state is based on the following:

- If a **normally closed float switch** (I.E. the switch is open when the fuel level is below the switch) is used, then set the option to Active High. This relates to the voltage level of the digital input pin of the EMCP 3.
- If a **normally open float switch** (I.E. the switch is closed when the fuel level is below the switch.) is used, then set the option to Active Low. This relates to the voltage level of the digital input pin of the EMCP 3.
- If a **normally closed contact** is used, then the voltage level of the digital input pin is pulled low when fuel is present. When the fuel level is below this switch, then the switch is activated and the contact opens, allowing the voltage level of the digital input pin to go high. This action indicates to the EMCP 3 that the switch has been operated.
- If a **normally open contact** is used, then the voltage level of the digital input pin is high when fuel is present. When the fuel level is below this switch, then the switch is activated and the contact closes, pulling the voltage level of the digital input pin low. This action indicates to the EMCP 3 that the switch has been operated.

3. Navigate to the EVENT I/P FUNCTIONS SELECT menu:

**Note:** Each press of the **Escape** key backs up one level in the menu structure. At this point in the procedure, the Escape key can be pressed twice until the SETPOINTS menu is highlighted and then the navigation can be completed. The complete menu map is:

```

MAIN MENU
.... CONFIGURE

```

..... SETPOINTS

..... EVENTS

..... EVENT I/P FUNCTIONS SELECT

**Note:** Event Input Function #1 corresponds to Digital Input #3, Event Input Function #2 corresponds to Digital Input #4, etc.

4. Select Event Input Function #1, and then press the **Enter** key in order to configure the settings. Using the navigation keys, scroll through the selections until the setting that is to be configured is highlighted and then press the **Enter** again in order to display the current value for that setting. The settings that can be configured include:

- Active state
- Time delay
- Suspect Parameter Number
- Failure Mode Identifier

5. Set the Active state. This appears in the menu as ACTIVE STATE CFG. The Active State should always be set to Active HIGH.

6. Set the Time delay. This appears in the menu as EVENT DELAY TIME. If a time delay is desired perform the following steps using the navigation keys in order to adjust the value to the desired number of seconds.

- a. Press the **Enter** key (10) in order to highlight the value.
- b. Using the **Scroll Right** and **Scroll Left** navigation keys, highlight each number that is to be changed. Once the number is highlighted, use the **Scroll Up** and the **Scroll Down** navigation keys in order to change the selected value to the desired value.
- c. Press the **Enter** key again in order to save the new value.

7. Set the Suspect Parameter Number (SPN). This value appears in the menu as SUSPECT PARM NUM/.

- a. Press the **Scroll Down** key and navigate to the LEVELS menu and then press the **Enter** key in order to select the menu.

- b. Using the **Scroll Down** key, navigate to the FUEL LEVEL parameter, and then press the **Enter** key in order to select this parameter. Per table 3, this setting will generate an SPN of "96".

8. Set the Failure Mode Indicator. This value appears in the menu as FAILURE MODE ID.

- a. Using the **Scroll Down** key, navigate to the LOW SHUTDOWN parameter, and then press the **Enter** key in order to select this parameter. Per table 4, this setting will generate an FMI of "1".

In summary, when the fuel level drops below the level of the float switch, Digital Input #3 is connected to battery negative through the switch. This generates an SPN-96, with an FMI-1. This code is translated by the EMCP 3 to shutdown the engine, turn on the shutdown LED, and broadcast the code on the J1939 data link. Any annunciator installed could be programmed to have a pair of LED indicators to detect this code and turn on the Red LED.

### Suspect Parameter Number (SPN)

Choose the SPN from Table 3.

Table 3

Supported SPNs	
SPN Description	SPN
Fuel Level (External Tank)	38
Aftercooler Temperature	52
Starting Air Pressure	82
Fuel Filter Differential Pressure	95
Fuel Level (Local Tank)	96
Engine Oil Level	98
Oil Filter Differential Pressure	99
Engine Oil Pressure	100
Crankcase Pressure	101
Air Filter Differential Pressure	107
Atmospheric Pressure	108
Engine Coolant Temperature	110
Engine Coolant Level	111
Fire Extinguisher Pressure	137
Battery Voltage (switched)	158
Battery Voltage	168
Ambient Air Temperature	171

(continued)

(Table 3, contd)

Supported SPNs	
SPN Description	SPN
Inlet Air Temperature	172
Exhaust Temperature	173
Engine Oil Temperature	175
Engine Speed	190
SCADA Data Link Fault	625
Primary Data Link (J1939 #1)	639
Event Input Function #1	701
Event Input Function #2	702
Event Input Function #3	703
Event Input Function #4	704
Event Input Function #5	705
Event Input Function #6	706
Event Input Function #7	707
Event Input Function #8	708
Event Input Function #9	709
Event Input Function #10	710
Event Input Function #11	711
Event Input Function #12	712
Event Input Function #13	713
Event Input Function #14	714
Event Input Function #15	715
Event Input Function #16	716
Emergency Stop Shutdown	970
Generator Bearing Temperature #1	1122
Generator Bearing Temperature #2	1123
Generator Winding Temperature #1	1124
Generator Winding Temperature #2	1125
Generator Winding Temperature #3	1126
Exhaust Gas Port 1 Temperature	1137
Exhaust Gas Port 2 Temperature	1138
Exhaust Gas Port 3 Temperature	1139
Exhaust Gas Port 4 Temperature	1140
Exhaust Gas Port 5 Temperature	1141
Exhaust Gas Port 6 Temperature	1142
Exhaust Gas Port 7 Temperature	1143
Exhaust Gas Port 8 Temperature	1144
Exhaust Gas Port 9 Temperature	1145
Exhaust Gas Port 10 Temperature	1146

(continued)

(Table 3, contd)

Supported SPNs	
SPN Description	SPN
Exhaust Gas Port 11 Temperature	1147
Exhaust Gas Port 12 Temperature	1148
Exhaust Gas Port 13 Temperature	1149
Exhaust Gas Port 14 Temperature	1150
Exhaust Gas Port 15 Temperature	1151
Exhaust Gas Port 16 Temperature	1152
Exhaust Gas Port 17 Temperature	1153
Exhaust Gas Port 18 Temperature	1154
Exhaust Gas Port 19 Temperature	1155
Exhaust Gas Port 20 Temperature	1156
Accessory Data Link Fault (J1939 #2)	1231
Emergency Shutdown Override Mode Active Warning	1237
Ruptured Fuel Basin - Primary Tank	1239
Unexpected Engine Shutdown	1383
Engine Failure to Start Shutdown	1664
Right Exhaust Temperature	2433
Left Exhaust Temperature	2434
Generator Frequency	2436
Generator AC Voltage	2440
Generator AC Current	2448
Generator Reverse Power (kW)	2452
Generator Reverse Power (kVAr)	2456
Service Interval Warning	2648
Air Damper Closed	4000
ATS in Normal Position	4001
ATS in Emergency Position	4002
Battery Charger Failure	4003
Generator Control Not in Automatic Warning	4007
Generator Breaker Failure to Open	4009
Utility Breaker Failure to Open	4010
Generator Breaker Failure to Close	4011
Utility Breaker Failure to Close	4012
Utility to Generator Transfer Failure Warning	4015
Generator to Utility Transfer Failure Warning	4016
Loss of Utility	4017

### Failure Mode Identifier (FMI)

Choose the FMI from Table 4.

Table 4

Failure Mode Identifier (FMI) Codes		
FMI	Description	Short Description
0	Data Valid but Above Normal Operational Range - Most Severe Level	High Shutdown
1	Data Valid but Below Normal Operational Range - Most Severe Level	Low Shutdown
2	Data Erratic, Intermittent or Incorrect	N/A
3	Voltage Above Normal or Shorted to High Source	N/A
4	Voltage Below Normal or Shorted to Low Source	N/A
5	Current Below Normal or Grounded Circuit	N/A
6	Current Above Normal or Grounded Circuit	N/A
7	Mechanical System Not Responding or Out of Adjustment	N/A
8	Abnormal Frequency, Pulse Width or Period	N/A
9	Abnormal Update Rate	N/A
10	Abnormal Rate of Change	N/A
11	Unexpected Engine Shutdown	N/A
12	Bad Intelligent Device or Component	N/A
13	Out of Calibration	N/A
14	Special Instructions	N/A
15	Data Valid But Above Normal Operating Range - Least Severe Level	High Warning
16	Data Valid But Above Normal Operating Range - Moderately Severe Level (Derate)	High Warning
17	Data Valid But Below Normal Operating Range - Least Severe Level	Low Warning
18	Data Valid But Below Normal Operating Range - Moderately Severe Level (Derate)	Low Warning

(continued)

(Table 4, contd)

Failure Mode Identifier (FMI) Codes		
FMI	Description	Short Description
19	Received Network Data In Error	N/A
31	Not Available or Condition Exists	Status

102451314

## Digital Input Programming

**SMCS Code:** 4490

There are two separate procedures that need to be performed in order to program the EMCP 3 digital inputs. The first procedure involves programming the **Active State** of the input as either "Active High" or as "Active Low". The second procedure involves programming the **Event Input Functions**.

### Digital Inputs

The main purpose for the digital inputs is to add additional monitoring capabilities for the engine or the generator. The inputs can be configured by navigating to the "EVENT I/P FUNCTIONS" parameter under the "SETPOINTS" menu.

**Note:** There are eight digital inputs on "EMCP 3.2" and "EMCP 3.3". There are six digital inputs on "EMCP 3.1". On all three levels of controls, the first and second digital inputs are dedicated and cannot be programmed.

The digital inputs of the EMCP 3 are tied to an internal pull-up resistor inside the control. Therefore, if there is no connection to a digital input, then the digital input will read as a logical high. A ground or battery negative input should be wired to each EMCP 3 digital input. If an Active High configuration is desired, then the ground or battery negative input should be wired through a normally closed switch. If an Active Low configuration is desired, then the ground or battery negative input should be wired through a normally open switch.

Digital Input #1 is dedicated for “Emergency Stop” and Digital Input #2 is dedicated for “Remote Initiate”. The other 4 or 6 inputs can be configured to trigger alarms or shutdowns in the EMCP 3. In the EMCP 3 software, Digital Inputs 3 through 8 (3 through 6 on EMCP 3.1) are linked to functions that are called “EVENT INPUT FUNCTIONS”. Because Digital Inputs #1 and #2 are dedicated inputs, Digital Input #3 is linked to Event Input Function #1, Digital Input #4 is linked to Event Input Function #2, and so on. See Illustration 9

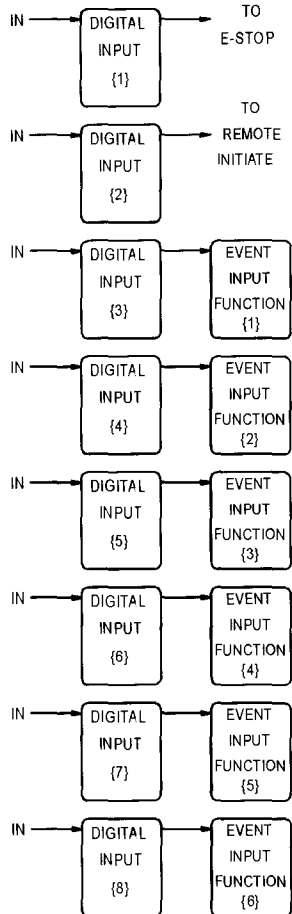

Illustration 9

g01228372

**Digital Input #1** – Digital Input #1 is used for “Emergency Stop”. This input should be wired to battery negative through an Emergency Stop switch. The input can be set to activate on an Active High (normally closed contact) or an Active Low (normally open contact). If the operator wants to enable the Reduced Power Mode, then Emergency Stop must be configured for Active Low.

**Reference:** Testing and Adjusting , “Electronic Control Module (Generator Set) - Configure”

Activating the Emergency Stop input will either cause the generator set to stop immediately or else it will prevent the generator set from starting. Once Digital Input #1 goes active, the engine will not start until the event is reset.

**Reference:** System Operation , “Event Resetting”

**Digital Input #2** – Digital Input #2 is used for remotely starting and stopping the generator set. This input should be wired to battery negative through a “Remote Initiate” switch. The input can be set to activate on an Active High (normally closed contact) or an Active Low (normally open contact). If the input is active, and the EMCP 3 is in the “AUTO” mode, then the engine will attempt to start and run. Once the input becomes inactive, the engine will enter into cooldown (if programmed to do so) and will then stop.

All remaining inputs can be configured.

## Function and Navigation Keys

**Reference:** Callouts in this section can be found on the EMCP 3 Control System Panel in Systems Operation, “Electronic Control Module (Generator Set)”

The keys listed below are used for programming the EMCP 3 and navigating within the menu structure.

**Reference:** For a full explanation of the use of the Function keys (Enter, Escape) and the Navigation keys (Scroll Left, Scroll Right, Scroll Up, Scroll Down) that are referenced in this section, see Systems Operation, “Electronic Control Module (Generator Set)”

**(9) Escape** – Navigate up (backward) through the menu structure and also used to cancel out of data entry screens during setpoint programming.

**(10) Enter key** – Select a highlighted menu item or save a programmed value.

**(11) Scroll Right key** – During numeric data entry, choose the digit to edit. During certain setpoint adjustments, select or deselect a checkbox.

**(12) Scroll Down key** – Move down through the main menu or navigate within a list in order to highlight one of the items. Also used to decrement digits (0-9).

**(13) Scroll Up key** – Move up through the main menu or navigate within a list in order to highlight one of the items. Also used to increment digits (0-9).

**(14) Scroll Left key** – During numeric data entry, choose the digit to edit. During certain setpoint adjustments, select or deselect a checkbox.

## Programming the Active State of the Digital Input

**Reference:** For an example of programming a digital input for a fuel level switch, see Systems Operation, "Setpoint Programming".

In order to program the "Active State" of the digital input, perform the following steps:

1. On the EMCP 3, navigate to the Digital Inputs menu as follows:

MAIN MENU

.... CONFIGURE

..... SETPOINTS

..... I/O

..... DIGITAL INPUTS

2. Using the navigation keys, select the Digital Input that is to be programmed and press the **Enter** key. The current configuration will be displayed.
3. Press the **Enter** key a second time. The current configuration will be highlighted.
4. Use the navigation keys in order to change the current configuration to the desired setting.
5. Press the **Enter** key in order to save the setting.

## Programming the Event Input Functions

**Note:** Event Input Function #1 corresponds to Digital Input #3, Event Input Function #2 corresponds to Digital Input #4, etc. See Illustration 9

**Note:** It is possible to set the Event Input function to a value for which no event response configuration exists, such as High Oil Pressure Warning or High Oil Pressure Shutdown. If this occurs, and the event is made Active, then no events will be triggered.

In order to program the "Event Input" functions, perform the following steps:

1. On the EMCP 3, navigate to the EVENT I/P FUNCTIONS menu as follows:

MAIN MENU

.... CONFIGURE

..... SETPOINTS

..... EVENTS

..... EVENT I/P FUNCTIONS

2. Set the "Active State". The Active State should always be set to Active HIGH. The next setting is the Time Delay. Press the **Enter** key and then enter the desired value using the navigation keys.
3. Set the **Time Delay**. Press the **Enter** key and enter the desired value using the navigation keys.
4. Set the **Suspect Parameter Number (SPN)**. Press the **Enter** key in order to choose the SPN. The available parameters are listed in Table 5.

Table 5

Available Parameters
<b>Pressures</b> Air Filter Differential Pressure Engine Oil Pressure Fire Extinguisher Pressure Fuel Filter Differential Pressure Oil Filter Differential Pressure Starting Air Pressure Gas Pressure
<b>Temperatures</b> Ambient Air Temperature Engine Coolant Temperature Engine Oil Temperature Exhaust Temperature Rear Bearing Temperature Right Exhaust Temperature Left Exhaust Temperature
<b>Levels</b> Engine Coolant Level Engine Oil Level Fuel Level External Tank Fuel Level
<b>Other</b> Air Damper Closed ATS in Normal Position ATS in Emergency Position Battery Charger Failure Battery Charging System Voltage Battery Voltage Fuel Leak Detected Custom Event Earth Fault Earth Leakage Generator Frequency Generator Voltage Generator Current Generator Power Loss of Utility Utility to Generator Transfer Failure Generator to Utility Transfer Failure

5. Set the **Failure Mode Identifier (FMI)**. The following FMI's are available:

- High Warning (example: High Temperature Warning)
- Low Warning (example: Low Temperature Warning)
- High Shutdown
- Low Shutdown
- Status

## Digital Output Programming

**SMCS Code:** 4490

**Note:** The EMCP 3.1 does not have any digital outputs. The EMCP 3.2 has one digital output. The EMCP 3.3 has two digital outputs.

Each digital output is capable of sinking 300mA. The outputs have diagnostics for a short to battery when the driver is on, as well as diagnostics for an open circuit when the driver is off. If a short to battery persists for five seconds, then the driver will be disabled until the condition is no longer present.

There are two separate procedures that need to be performed in order to program the Digital Outputs. The first procedure involves programming the **Active State** of the output as either "Active High" or else as "Active Low". The second procedure involves programming the **Digital Selectors**.

## Function and Navigation Keys

**Reference:** Callouts in this section can be found on the EMCP 3 Control System Panel in Systems Operation, "Electronic Control Module (Generator Set)"

The keys listed below are used for programming the EMCP 3 and navigating within the menu structure.

**Reference:** For a full explanation of the use of the Function keys (Enter, Escape) and the Navigation keys (Scroll Left, Scroll Right, Scroll Up, Scroll Down) that are referenced in this section, see Systems Operation, "Electronic Control Module (Generator Set)"

**(9) Escape** – Navigate up (backward) through the menu structure and also used to cancel out of data entry screens during setpoint programming.

**(10) Enter key** – Select a highlighted menu item or save a programmed value.

**(11) Scroll Right key** – During numeric data entry, choose the digit to edit. During certain setpoint adjustments, select or deselect a checkbox.

**(12) Scroll Down key** – Move down through the main menu or navigate within a list in order to highlight one of the items. Also used to decrement digits (0-9).

**(13) Scroll Up key** – Move up through the main menu or navigate within a list in order to highlight one of the items. Also used to increment digits (0-9).

**(14) Scroll Left key** – During numeric data entry, choose the digit to edit. During certain setpoint adjustments, select or deselect a checkbox.

## Programming the Active State of the Digital Output

**Note:** The outputs are internally controlled in the EMCP 3. The active state is programmable but should always be set to Active High.

In order to program the “Active State” of the digital output, perform the following steps:

1. On the EMCP 3, navigate to the **Digital Outputs** menu as follows:

MAIN MENU

.... CONFIGURE

..... SETPOINTS

..... I/O

..... DIGITAL OUTPUTS

2. Using the navigation keys, select the digital output that is to be programmed and press the **Enter** key.
3. Press the **Enter** key a second time. The current configuration will be highlighted.
4. Use the navigation keys in order to change the current configuration to the desired setting.
5. Press the **Enter** key in order to save the setting.

## Programming the Digital Selectors

Digital outputs on EMCP 3.2 and 3.3 are programmable and can be set to operate based on different conditions. In order to do this, there are functions called digital selectors associated with each digital output. There are eight digital selectors. The digital selectors determine which conditions result in the digital outputs becoming “Active”. Only Digital Selector #7 and Digital Selector #8 are associated with digital outputs.

The digital selector is a software function that acts like a 12 position switch. For each output there are 11 different options or conditions that can make the output go active, and one condition to disable the output altogether. The digital selector is used in order to determine which one of those conditions will actually be associated with each digital output. This relationship is shown in Illustration 10. In addition to the ten options shown in the Illustration, the digital selectors can be configured to receive their activation commands over the SCADA data link.

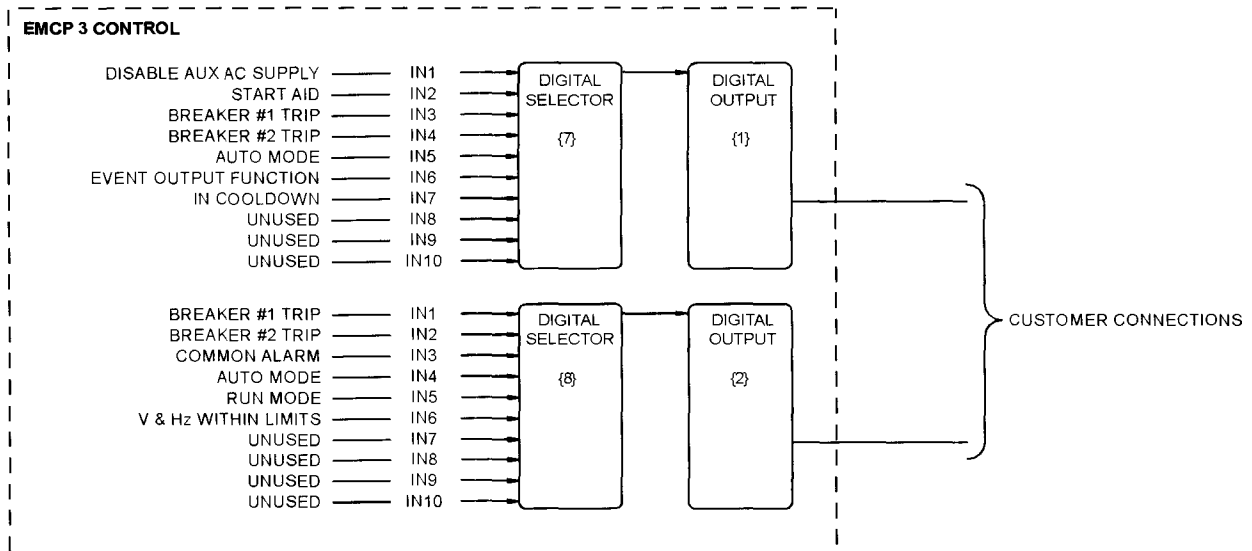

Illustration 10

g01228373

In order to program the digital selectors, perform the following steps:

1. On the EMCP 3, navigate to the **Digital Selectors** menu as follows:

MAIN MENU

.... CONFIGURE

..... OTHER

..... DIGITAL SELECTORS

2. Using the navigation keys, select the digital selector that is to be programmed and press the **Enter** key.
3. Press the **Enter** key a second time. The current configuration will be highlighted.
4. Use the navigation keys in order to change the current configuration to the desired setting
5. Press the **Enter** key in order to save the setting.

### Available Digital Selectors

#### Digital Selector #7

Digital Selector #7 controls Digital Output #1. The available configuration options for Digital Selector #7 are shown in Table 6.

Table 6

Digital Selector #7 Configuration Options	
Display Text	Condition
Disabled	Disabled
Use Input #1 <sup>(1)</sup>	Disable Aux AC Supply <sup>(1)</sup>
Use Input #2	Start Aid
Use Input #3	Breaker Trip 1
Use Input #4	Breaker Trip 2
Use Input #5	Auto Mode
Use Input #6	Event Output Function
Use Input #7	In Cooldown
Use Input #8	Reserved for future use
Use Input #9	Reserved for future use
Use Input #10	Reserved for future use
Use Data Link Input	Use SCADA Data Link Command

<sup>(1)</sup> Default

#### Digital Selector #8

Digital Selector #8 controls Digital Output #2. The available configuration options for Digital Selector #8 are shown in Table 7.

Table 7

Digital Selector #8 Configuration Options	
Display Text	Condition
Disabled <sup>(1)</sup>	Disabled <sup>(1)</sup>
Use Input #1	Breaker Trip 1
Use Input #2	Breaker Trip 2
Use Input #3	Common Alarm
Use Input #4	Auto Mode
Use Input #5	Run Mode
Use Input #6	V & Hz Within Limits
Use Input #7	Reserved for future use
Use Input #8	Reserved for future use
Use Input #9	Reserved for future use
Use Input #10	Reserved for future use
Use Data Link Input	Use SCADA Data Link Command

<sup>(1)</sup> Default

### Description of Digital Selector Inputs Used to Activate the Digital Outputs

#### Start Aid

- Requires that the setpoint for “Start Aid Activation Time” is to be set greater than zero
- Activated when engine start is initiated. Engine start also starts the timer.
- Deactivates after Start Aid Activation Time expires

#### Common Alarm

- Activated any time that the EMCP 3 initiates and/or detects either a shutdown or a warning event
- Deactivates when no warnings or shutdowns are present or active

#### Disable Aux AC Supply

- Activated when engine start is initiated
- Deactivates when the engine is stopped

#### Breaker Trip 1

- Activated when any event occurs that has an event response configuration set for “breaker trip 1”
- Deactivates when the event is neither present nor active

#### NOTICE

This output does not control a circuit breaker unless the user makes the connections to do so. This output type should be viewed as having a generic name because the name does not necessarily imply the action that is performed.

#### Breaker Trip 2

- Activated when any event occurs that has an event response configuration set for “breaker trip 2”
- Deactivates when the event is neither present nor active

#### NOTICE

This output does not control a circuit breaker unless the user makes the connections to do so. This output type should be viewed as having a generic name because the name does not necessarily imply the action that is performed.

#### Event Output Function

- Requires setpoint configuration for Event Output 1
- Activated while Event Output 1 is active

#### V&Hz Within Limits

**Note:** The **normal operating range** is defined as being neither above the “high” warning or shutdown thresholds, nor below the “low” warning or shutdown thresholds.

- Activated when measured generator voltage and frequency, which is calculated as a percentage of rated voltage and frequency, are both within the normal operating range.
- Deactivates when either the measured generator voltage or the frequency are outside the normal operating range.

#### In Cooldown

- Requires that the “Cooldown Duration” setpoint is to be set greater than zero
- Activated when an engine stop has been initiated and the cooldown cycle begins
- Deactivates when the cooldown timer has expired

#### Auto Mode

Activated after the **Auto** key has been pressed and while the EMCP 3 remains in the auto mode

## Run Mode

Activated after the **Run** key has been pressed and while the EMCP 3 remains in the run mode

i02453890

## Spare Analog Input Programming

**SMCS Code:** 4490

The "Spare Analog Input" is intended to be connected to a resistive sender such as the Coolant Temperature Sensor or the Oil Pressure Sensor. Each analog input is capable of reading a 0-2k ohm resistive sender.

**Note:** The EMCP 3.1 does not have a Spare Analog Input. The EMCP 3.2 and the EMCP 3.3 each have a single Spare Analog Input.

**Note:** The R/T map in the EMCP 3 for the Spare Analog Input differs between EUI engines, where the input is reserved for user defined purposes, and MUI engines which use the input for oil temperature.

The Spare Analog Input is configurable for six specific temperatures. In addition to temperatures, this input can be factory set to monitor pressures and to monitor levels. Consult the factory for information about applications that use the Spare Analog Input.

## Menu Navigation

The EMCP 3 Spare Analog Input menu, which is used for programming the input, can be navigated to as follows:

MAIN MENU

.... CONFIGURE

..... SETPOINTS

..... I/O

..... SPARE ANALOG INPUT

## Configurable Parameters

Parameters that can be configured for the Spare Analog Input include:

- Enable/Disable
- Suspect Parameter Number
- Thresholds and time delays

## Enable/Disable

- If the Spare Analog Input **is used**, then the Enable/Disable setpoint must first be **enabled**
- If the Spare Analog Input **is not used**, then the Enable/Disable setpoint must be **disabled**
- If the Spare Analog Input is enabled, but is not being used, then diagnostic codes will be logged

## Suspect Parameter Number (SPN)

The following temperature SPN's are available for configuration:

- Ambient Air Temperature
- Engine Oil Temperature
- Exhaust Temperature
- Right Exhaust Temperature
- Left Exhaust Temperature
- Rear Bearing Temperature

## Additional Parameters

The following threshold and time delay parameters are numerical value entries.

- High Warning Time Delay
- High Shutdown Threshold
- High Shutdown Time Delay
- Low Warning Threshold
- Low Warning Time Delay
- Low Shutdown Threshold
- Low Shutdown Time Delay

i02454089

## Relay Output Programming

**SMCS Code:** 4490

**Note:** The EMCP 3.1 has six programmable Type A relays. The EMCP 3.2 and EMCP 3.3 have eight programmable relays. Six of these are Type A relays and the other two are Type C relays. Type A relays contain a common and one normally-open contact. Type C relays contain a common and two contacts, one that is normally-open and one that is normally-closed.

Each relay is capable of handling 2A @ 30VDC. The relays are “volt free” meaning that the commons are not referenced to anything within the control. The relay contacts are not protected against shorts to battery or ground. Two of the relays are dedicated and cannot be programmed. Relay Output #1 is dedicated to controlling the starter motor. Relay Output #2 is dedicated to fuel enable. The six remaining Relay Outputs on the EMCP 3.3 and EMCP 3.2 and four remaining Relay Outputs on the EMCP 3.1 are programmable and can be set to operate based on different conditions.

In order to program the Relay Outputs, the Digital Selectors must be programmed.

## Function and Navigation Keys

**Reference:** Callouts in this section can be found on the EMCP 3 Control System Panel in Systems Operation, “Electronic Control Module (Generator Set)”

The keys listed below are used for programming the EMCP 3 and navigating within the menu structure.

**Reference:** For a full explanation of the use of the Function keys (Enter, Escape) and the Navigation keys (Scroll Left, Scroll Right, Scroll Up, Scroll Down) that are referenced in this section, see Systems Operation, “Electronic Control Module (Generator Set)”

**(9) Escape** – Navigate up (backward) through the menu structure and also used to cancel out of data entry screens during setpoint programming.

**(10) Enter key** – Select a highlighted menu item or save a programmed value.

**(11) Scroll Right key** – During numeric data entry, choose the digit to edit. During certain setpoint adjustments, select or deselect a checkbox.

**(12) Scroll Down key** – Move down through the main menu or navigate within a list in order to highlight one of the items. Also used to decrement digits (0-9).

**(13) Scroll Up key** – Move up through the main menu or navigate within a list in order to highlight one of the items. Also used to increment digits (0-9).

**(14) Scroll Left key** – During numeric data entry, choose the digit to edit. During certain setpoint adjustments, select or deselect a checkbox.

## Digital Selector Programming

There are eight digital selectors. The digital selectors determine which conditions cause the Relay Outputs to become active. Only six of the digital selectors are associated with Relay Outputs.

The digital selector is a software function that acts like a 10 position switch. For each relay there are 10 different options of conditions that can operate the relay. The digital selector is used in order to determine which one of those conditions will actually be associated with each relay output. EMCP 3.1 has 4 digital selectors, EMCP 3.2 has seven digital selectors, and EMCP 3.3 has eight digital selectors. On EMCP 3.2 and 3.3, only the first six digital selectors are for the relay outputs. The remaining digital selectors are for the digital outputs.

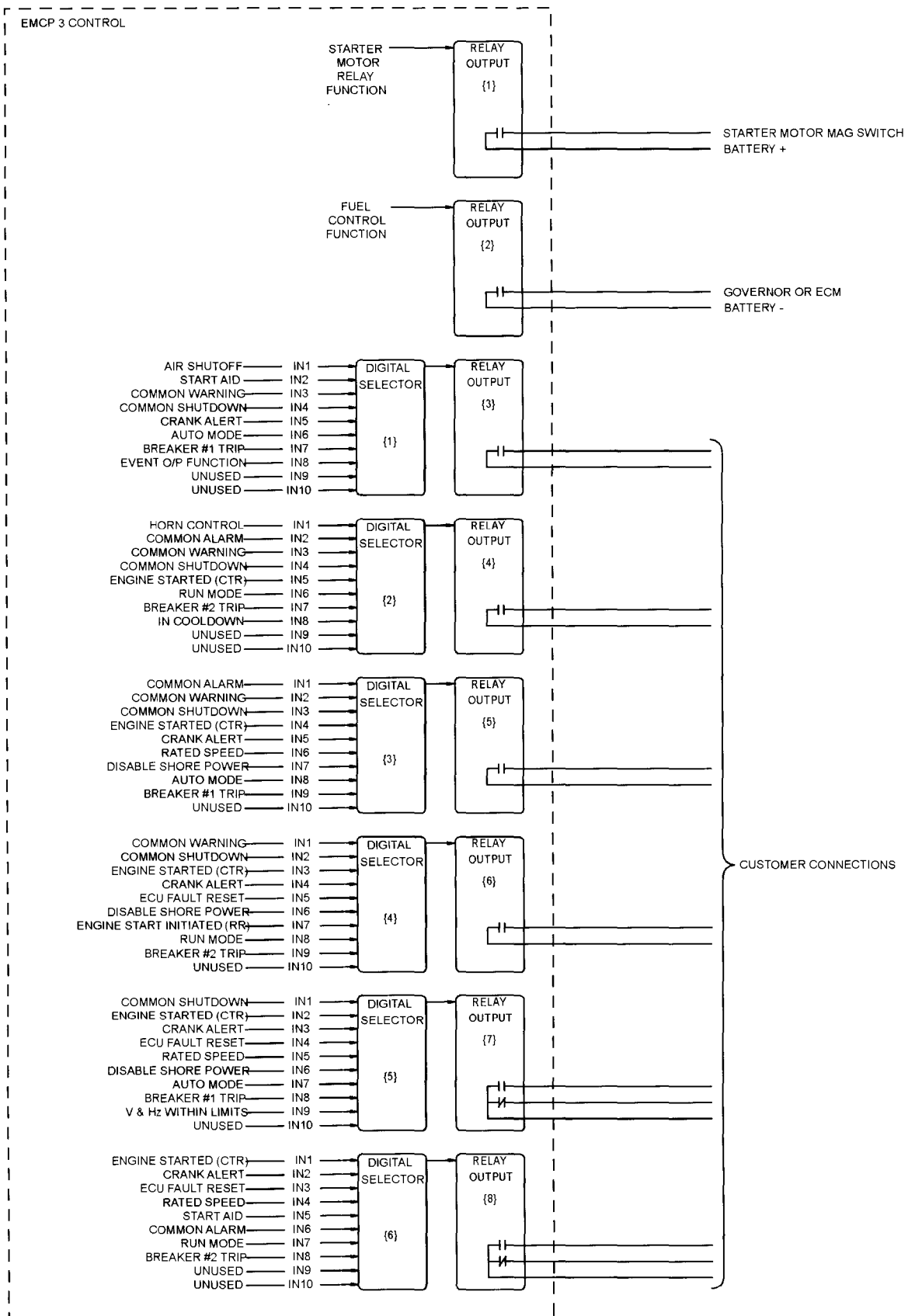

Illustration 11  
Digital Selectors being used to program Relay Outputs

In order to program the digital selectors, perform the following steps:

1. On the EMCP 3, navigate to the **DIGITAL SELECTORS** menu as follows:

MAIN MENU  
.... CONFIGURE  
..... SETPOINTS  
..... OTHER  
..... DIGITAL SELECTORS

2. Select the digital selector that is to be programmed, and then press the **Enter** key.
3. Press the **Enter** key again a second time. The current configuration will be highlighted.
4. Use the navigation keys in order to change the current configuration to the desired setting
5. Press the **Enter** key in order to save the setting.

### Digital Selector Input Descriptions

#### Air Shutoff

- Activated by the Emergency Stop condition while the engine is running
- Activated by an Overspeed condition
- Automatically deactivates after a five second delay

#### Start Aid

- Requires that the setpoint for "Start Aid Activation Time" is to be set greater than zero
- Activated when engine start is initiated. Engine start also starts the timer
- Deactivates after Start Aid Activation Time expires

#### Common Warning

- Activated whenever the EMCP 3 initiates a warning event or detects a warning event
- Deactivates when there are no warnings present

#### Common Shutdown

- Activated whenever the EMCP 3 initiates a shutdown event or detects a shutdown event

- Deactivates when there are no active or present shutdowns

#### Common Alarm

- Activated whenever the EMCP 3 initiates a shutdown event or detects a shutdown event
- Activated whenever the EMCP 3 initiates a warning event or detects a warning event
- Deactivates when no warnings and no shutdowns are active or present

#### Crank Alert

- Requires that the "Crank Alert Activation Time" be set to a value greater than zero
- Activated when the engine start is initiated. This action also starts the timer.
- Deactivates after the Crank Alert Activation Timer expires

#### Engine Start Initiated

- Activates whenever the engine start is initiated
- Deactivates when engine stop is initiated or the cooldown cycle begins

#### Engine Started

- Activated whenever the engine has reached its "crank terminate speed"
- Deactivates when the engine has stopped

#### Rated Speed

- Activated any time that rated speed is permitted

**Note:** Intended to provide a rated speed permissive signal to a governor on an MUI engine

#### Horn Control

- Activated when any event occurs that has an event response configuration set for "audible alert"
- Deactivates whenever the event is neither present nor active
- Deactivates whenever the acknowledge/horn silence key is pressed

#### ECU Fault Reset

- Activated when the EMCP 3 is in STOP mode and any event reset is being initiated.

**Note:** This output is intended for resetting events in an ECM when there is no J1939 communication available in the ECM, such as in the case of an ADEM II controller. The engine type must be set to "Electronic" and J1939 support must be set to "No J1939 Support".

### Disable Aux AC Supply

- Activated when engine start is initiated
- Deactivates when the engine is stopped

### Breaker Trip 1

- Activated when any event occurs that has an event response configuration set for "breaker trip 1"
- Deactivates when the event is neither present nor active

---

#### NOTICE

This output does not control a circuit breaker unless the user creates the connections for this function. This output type should be viewed as having a generic name because the name does not necessarily imply the action that is performed.

---

### Breaker Trip 2

- Activated when any event occurs that has an event response configuration set for "breaker trip 2"
- Deactivates when the event is neither present nor active

---

#### NOTICE

This output does not control a circuit breaker unless the user creates the connections for this function. This output type should be viewed as having a generic name because the name does not necessarily imply the action that is performed.

---

### Event Output Function

- Requires setpoint configuration for Event Output 1
- Activated while Event Output 1 is active

### V&Hz Within Limits

**Note:** The **normal operating range** is defined as being neither above the "high" shutdown threshold, nor below the "low" shutdown threshold.

- Activated when measured generator voltage and frequency, which is calculated as a percentage of rated voltage and frequency, are both within the normal operating range.

- Deactivates when either the measured generator voltage or the frequency are outside the normal operating range.

### In Cooldown

- Requires that the "Cooldown Duration" setpoint is to be set greater than zero
- Activated when an engine stop has been initiated and the cooldown cycle begins
- Deactivates when the cooldown timer has expired

### Auto Mode

Activated after the **Auto** key has been pressed and while the EMCP 3 remains in the auto mode

### Run Mode

Activated after the **Run** key has been pressed and while the EMCP 3 remains in the run mode

## Digital Selector Configuration Options

### Digital Selector #1

Digital Selector #1 controls Relay Output #3. Table 8 lists the configuration options that are available for Digital Selector #1.

Table 8

Digital Selector #1 configuration Options	
Display Text	Condition
Disabled	Disabled
Use Input #1 <sup>(1)</sup>	Air Shutoff <sup>(1)</sup>
Use Input #2 <sup>(2)</sup>	Start Aid <sup>(2)</sup>
Use Input #3	Common Warning
Use Input #4	Common Shutdown
Use Input #5	Crank Alert
Use Input #6	Auto Mode
Use Input #7	Breaker Trip 1
Use Input #8	Event Output Function
Use Input #9	Reserved for future use
Use Input #10	Reserved for future use
Use Data Link Input	Use SCADA Data Link Command

<sup>(1)</sup> Default for MUI

<sup>(2)</sup> Default for EUI

### Digital Selector #2

Digital Selector #2 controls Relay Output #4. Table 9 lists the configuration options that are available for Digital Selector #2.

Table 9

Digital Selector #2 Configuration Options	
Display Text	Condition
Disabled	Disabled
Use Input #1	Horn Control
Use Input #2	Common Alarm
Use Input #3	Common Warning
Use Input #4 <sup>(1)</sup>	Common Shutdown <sup>(1)</sup>
Use Input #5	Engine Started
Use Input #6	Run Mode
Use Input #7	Breaker Trip 2
Use Input #8	In Cooldown
Use Input #9	Reserved for future use
Use Input #10	Reserved for future use
Use Data Link Input	Use SCADA Data Link Command

<sup>(1)</sup> Default

### Digital Selector #3

Digital Selector #3 controls Relay Output #5. Table 10 lists the configuration options that are available for Digital Selector #3.

Table 10

Digital Selector #3 Configuration Options	
Display Text	Condition
Disabled <sup>(1)</sup>	Disabled <sup>(1)</sup>
Use Input #1	Common Alarm
Use Input #2	Common Warning
Use Input #3	Overcrank Shutdown
Use Input #4	Engine Started
Use Input #5	Crank Alert
Use Input #6 <sup>(2)</sup>	Rated Speed <sup>(2)</sup>
Use Input #7	Disable Aux AC Supply
Use Input #8	Auto Mode
Use Input #9	Breaker Trip 1
Use Input #10	Reserved for future use
Use Data Link Input	Use SCADA Data Link Command

<sup>(1)</sup> Default for EUI

<sup>(2)</sup> Default for MUI

### Digital Selector #4

Digital Selector #4 controls Relay Output #6. Table 11 lists the configuration options that are available for Digital Selector #4.

Table 11

Digital Selector #4 Configuration Options	
Display Text	Condition
Disabled <sup>(1)</sup>	Disabled <sup>(1)</sup>
Use Input #1	Common Warning
Use Input #2	Common Shutdown
Use Input #3	Engine Started
Use Input #4	Crank Alert
Use Input #5	ECU Fault Reset
Use Input #6 <sup>(2)</sup>	Disable Aux AC Supply <sup>(2)</sup>
Use Input #7	Engine Start Initiated
Use Input #8	Run Mode
Use Input #9	Breaker Trip #2
Use Input #10	Reserved for future use
Use Data Link Input	Use SCADA Data Link Command

(1) Default for EMCP 3.2 and EMCP 3.3

(2) Default for EMCP 3.1

**Digital Selector #5**

Digital Selector #5 controls Relay Output #7. Table 12 lists the configuration options that are available for Digital Selector #5

Table 12

Digital Selector #5 Configuration Options	
Display Text	Condition
Disabled <sup>(1)</sup>	Disabled <sup>(1)</sup>
Use Input #1	Common Shutdown
Use Input #2	Engine Started
Use Input #3	Crank Alert
Use Input #4	ECU Fault Reset
Use Input #5	Rated Speed
Use Input #6	Disable Aux AC Supply
Use Input #7	Auto Mode
Use Input #8	Breaker Trip 1
Use Input #9	V&Hz Within Limits
Use Input #10	Reserved for future use
Use Data Link Input	Use SCADA Data Link Command

(1) Default

**Digital Selector #6**

Digital Selector #6 controls Relay Output #8. Table 13 lists the available configuration options for Digital Selector #6.

Table 13

Digital Selector #6 Configuration Options	
Display Text	Condition
Disabled <sup>(1)</sup>	Disabled <sup>(1)</sup>
Use Input #1	Engine Started
Use Input #2	Crank Alert
Use Input #3	ECU Fault Reset
Use Input #4	Rated Speed
Use Input #5	Start Aid
Use Input #6	Common Alarm
Use Input #7	Run Mode
Use Input #8	Breaker Trip 2
Use Input #9	Reserved for future use
Use Input #10	Reserved for future use
Use Data Link Input	Use SCADA Data Link Command

(1) Default

i02455559

**Voltage and Frequency Adjustment**

SMCS Code: 4490

**Function and Navigation Keys**

**Reference:** Callouts in this section can be found on the EMCP 3 Control System Panel in Systems Operation, "Electronic Control Module (Generator Set)"

The keys listed below are used for programming the EMCP 3 and navigating within the menu structure.

**Reference:** For a full explanation of the use of the Function keys (Enter, Escape) and the Navigation keys (Scroll Left, Scroll Right, Scroll Up, Scroll Down) that are referenced in this section, see Systems Operation, "Electronic Control Module (Generator Set)"

**(9) Escape** – Navigate up (backward) through the menu structure and also used to cancel out of data entry screens during setpoint programming.

**(10) Enter key** – Select a highlighted menu item or save a programmed value.

**(11) Scroll Right key** – During numeric data entry, choose the digit to edit. During certain setpoint adjustments, select or deselect a checkbox.

**(12) Scroll Down key** – Move down through the main menu or navigate within a list in order to highlight one of the items. Also used to decrement digits (0-9).

**(13) Scroll Up key** – Move up through the main menu or navigate within a list in order to highlight one of the items. Also used to increment digits (0-9).

**(14) Scroll Left key** – During numeric data entry, choose the digit to edit. During certain setpoint adjustments, select or deselect a checkbox.

## Adjustment

Use the following procedure in order to adjust the voltage and frequency of the generator output.

1. From the MAIN MENU, use the **Scroll Down** key or the **Scroll Up** key in order to navigate to the "CONTROL" menu.
  - a. Press the **Enter** key in order to select the CONTROL menu. "ADJUST SPEED" and "ADJUST VOLTAGE" will be displayed.

**Note:** The voltage can only be controlled from the EMCP 3 if a CDVR is installed on the generator and the EMCP is a version 3.3. Speed can only be controlled if there is an ADEM 3 or newer ECM on the engine.

- b. Press the **Scroll Up** key in order to increase the voltage and press the **Scroll Down** key in order to decrease the voltage.

**Note:** When adjusting the voltage using the Scroll Up and Scroll Down keys, an offset is applied to the setpoint value for "Generator Nominal Output Voltage". This setpoint is transmitted over the J1939 primary data link to the CDVR voltage regulator and is retained until battery power is cycled to the EMCP 3. Cycling the battery power to the EMCP 3 will remove the offset. Once the offset is removed, the transmitted value reverts back to the setpoint value for "Generator Nominal Output Voltage".

- c. Press the **Scroll Left** key in order to decrease the engine speed and press the **Scroll Right** key in order to increase the engine speed.

**Note:** When adjusting the frequency using the Scroll Left and Scroll Right keys, an offset is applied to the setpoint value for "Generator Nominal Output Frequency". This setpoint is transmitted over the J1939 primary data link to the engine controller and is retained until battery power is cycled to the EMCP 3. Cycling the battery power to the EMCP 3 will remove the offset. Once the offset is removed, the transmitted value reverts back to the setpoint value for "Generator Nominal Output Frequency".

i02457230

## Real Time Clock Programming

**SMCS Code:** 4490

The real time clock provides accurate information for the time and the date of an automatic time based start/stop control. The real time clock provides a mechanism for time stamps in the event log.

**Note:** The EMCP 3.1 does not utilize a real time clock for time stamping.

The EMCP 3 keeps track of the time and the date using an internal real time clock with an internal battery backed up memory. The time and the date will be maintained by the internal battery even when the control battery power is disconnected.

After the internal battery fails, the real time clock will continue to keep time only when the control battery power is connected. If the control battery power is disconnected, then the real time clock must be reprogrammed when the EMCP 3 is powered up again.

## Function and Navigation Keys

**Reference:** Callouts in this section can be found on the EMCP 3 Control System Panel in Systems Operation, "Electronic Control Module (Generator Set)"

The keys listed below are used for programming the EMCP 3 and navigating within the menu structure.

**Reference:** For a full explanation of the use of the Function keys (Enter, Escape) and the Navigation keys (Scroll Left, Scroll Right, Scroll Up, Scroll Down) that are referenced in this section, see Systems Operation, "Electronic Control Module (Generator Set)"

**(9) Escape** – Navigate up (backward) through the menu structure and also used to cancel out of data entry screens during setpoint programming.

**(10) Enter key** – Select a highlighted menu item or save a programmed value.

**(11) Scroll Right key** – During numeric data entry, choose the digit to edit. During certain setpoint adjustments, select or deselect a checkbox.

**(12) Scroll Down key** – Move down through the main menu or navigate within a list in order to highlight one of the items. Also used to decrement digits (0-9).

**(13) Scroll Up key** – Move up through the main menu or navigate within a list in order to highlight one of the items. Also used to increment digits (0-9).

**(14) Scroll Left key** – During numeric data entry, choose the digit to edit. During certain setpoint adjustments, select or deselect a checkbox.

## Programming the Time and Date

In order to program the time and the date in the EMCP 3 perform the following steps:

1. From the MAIN MENU, press the **Scroll Up** key or the **Scroll Down** key in order to highlight the CONFIGURE menu.
2. Press the **Enter** key in order to select CONFIGURE. SECURITY is highlighted.
3. Press the **Scroll Down** key in order to highlight TIME/DATE.
4. Press the **Enter** key in order to select TIME/DATE. SET TIME/DATE is displayed. Also shown is the current time and date that is programmed into the EMCP 3. The currently programmed time is shown highlighted inside a box.
5. Press the **Enter** key. SET TIME and the currently programmed time are displayed.
6. Press the **Enter** key. The six digit time will be displayed. The seconds will be highlighted at the far right.
7. Use the **Scroll Right** key or the **Scroll Left** key in order to highlight the digit that is to be programmed.
8. Press the **Scroll Up** key or the **Scroll Down** key in order to increment or decrement the highlighted digit to the desired number.
9. Continue until the correct time has been entered. When all digits of the time are correctly entered, press the **Enter** key. SET TIME is shown with the newly programmed time highlighted.
10. Press the **Escape** key once. SET TIME/DATE is shown and the newly programmed time will be displayed inside a box.
11. Press the **Scroll Right** key in order to highlight the currently programmed date inside a box. Press the **Enter** key in order to select the date. "SET DATE" and the currently programmed date are displayed.
12. Press the **Enter** key in order to select the date. An eight digit display is shown. The year is highlighted at the far right.
13. Use the **Scroll Right** key or the **Scroll Left** key in order to highlight the digit that is to be programmed.
14. Press the **Scroll Up** key or the **Scroll Down** key in order to increment or decrement the highlighted digit to the desired number.
15. Continue until the correct date has been entered. When all eight digits of the date are correctly entered, press the **Enter** key. SET DATE is shown with the newly programmed date highlighted.
16. Press the **Scroll Down** key in order to highlight FORMAT and then press the **Enter** key in order to select FORMAT. The current date format will be highlighted.
17. Press the **Scroll Right** or the **Scroll Left** key in order to change to the desired format, either DD/MM/YY or MM/DD/YY.
18. Press the **Escape** key three times in order to return to the MAIN MENU screen.

i02425223

## Thermocouple Module

SMCS Code: 7490

### [ OPTIONAL USE ]

This is not a required module.

## General Information

Thermocouples, which consist of a probe that is connected to two wires, are devices that are used for measuring relatively high temperatures. The probe is placed a specific distance away from the heat source that is to be measured. The wires are connected to a measuring device. The wires are made up of dissimilar metals that are connected at two different junctions. The first junction is for measuring the temperature and the second junction, which is attached to the Thermocouple Module, is used as a reference. When the two metals are joined, a voltage is generated that relates to the difference in temperature between the two junctions.

The Thermocouple Module reads the voltage and then calculates the temperature in "Celsius". After the calculations are complete, the Thermocouple Module broadcasts the information onto the "J1939" data link. Once on the data link, the EMCP 3 reads the information and displays it on the display screen, eliminating the need for a pyrometer or similar separate display unit.

Thermocouples are given a "Type" designation that is based on the range of temperatures that the thermocouple can accurately measure. The Thermocouple Module is capable of reading twenty reference inputs from either "Type-J" or "Type-K" thermocouples.

## Diagnostics

The Thermocouple Module is capable of generating diagnostics and can store up to twenty diagnostic log entries that can be viewed from the EMCP 3. The generated diagnostics are maintained in non-volatile memory in order to ensure availability after a power loss. The format for each of the log entries is listed in Table 14.

Table 14

Diagnostic Log Entry Format
Suspect Parameter Number (SPN) <sup>(1)</sup>
Failure Mode Indicator (FMI) <sup>(2)</sup>
Time of Last Occurrence
Date of Last Occurrence
Time of First Occurrence
Date of First Occurrence
Engine Run Hours First Occurrence
Engine Run Hours Last Occurrence
Number of Occurrences
Security to Clear Log Entry

(1) Refer to Table 16 for possible code numbers.

(2) Refer to Table 15 for possible code numbers.

Twenty thermocouple inputs can be connected to a Thermocouple Module. The module can detect both open circuits and short circuits for any of the twenty inputs. Additionally, sensor diagnostics detect overtemperature warnings and shutdowns, as well as undertemperature warnings. These warnings are detected by comparing the measured temperature to the "low warning", "high warning", and "high shutdown temperature" setpoints that are stored in the module.

The diagnostic messages listed in Table 15 are broadcast on the "J1939" data link. The EMCP 3 controller reads these messages and can provide both an annunciation for the operator and can also perform a soft shutdown of the engine as appropriate. Any of the inputs can be disabled in order to prevent unnecessary diagnostic faults.

Table 15

FMI Codes - Thermocouple Module Diagnostics	
FMI	Description
0	Thermocouple Input #n High Temperature Shutdown
4	Thermocouple Input Sensor #n Short Circuit
5	Thermocouple Input Sensor #n Open Circuit
15	Thermocouple( Input #n) High Temperature Warning
17	Thermocouple (Input #n) Low Temperature Warning

## Monitoring Features

Thermocouples are given a "Type" designation that is based on the range of temperatures that the thermocouple can accurately measure. The Thermocouple Module monitors twenty "Type-J" or "Type-K" thermocouple inputs.

Each input is fully configurable and can be set to any "SAE J1939" Suspect Parameter Number (SPN) that is listed in Table 16. An SPN is an internationally recognized trouble code that is designated with a specific meaning. For example, SPN 174 is designated as "Fuel Temperature".

The display units are selectable at the EMCP 3 controller as either Degrees Fahrenheit or as Celsius. All monitored values are available on the data link as read-only information. Temperatures are configured to indicate the SPN that is transmitted by each temperature input.

Table 16

SPNs Available for Configuration of Temperature Inputs	
SPN	Description
52	Engine Intercooler Temperature
105	Intake Manifold 1 Temperature
110	Engine Coolant Temperature
171	Ambient Air Temperature
172	Air Inlet Temperature
173	Exhaust Gas Temperature
174	Fuel Temperature
175	Engine Oil Temperature 1
176	Turbo Oil Temperature
441	Auxiliary Temperature 1
442	Auxiliary Temperature 2
1122	Alternator Bearing 1 Temperature
1123	Alternator Bearing 2 Temperature
1124	Alternator Winding 1 Temperature
1125	Alternator Winding 2 Temperature
1126	Alternator Winding 3 Temperature
1131	Intake Manifold 2 Temperature
1132	Intake Manifold 3 Temperature
1133	Intake Manifold 4 Temperature
1135	Engine Oil Temperature 2
1137	Exhaust Gas Port 1 Temperature
1138	Exhaust Gas Port 2 Temperature
1139	Exhaust Gas Port 3 Temperature

(continued)

(Table 16, contd)

SPNs Available for Configuration of Temperature Inputs	
SPN	Description
1140	Exhaust Gas Port 4 Temperature
1141	Exhaust Gas Port 5 Temperature
1142	Exhaust Gas Port 6 Temperature
1143	Exhaust Gas Port 7 Temperature
1144	Exhaust Gas Port 8 Temperature
1145	Exhaust Gas Port 9 Temperature
1146	Exhaust Gas Port 10 Temperature
1147	Exhaust Gas Port 11 Temperature
1148	Exhaust Gas Port 12 Temperature
1149	Exhaust Gas Port 13 Temperature
1150	Exhaust Gas Port 14 Temperature
1151	Exhaust Gas Port 15 Temperature
1152	Exhaust Gas Port 16 Temperature
1153	Exhaust Gas Port 17 Temperature
1154	Exhaust Gas Port 18 Temperature
1155	Exhaust Gas Port 19 Temperature
1156	Exhaust Gas Port 20 Temperature
1157	Main Bearing 1 Temperature (engine)
1158	Main Bearing 2 Temperature (engine)
1159	Main Bearing 3 Temperature (engine)
1160	Main Bearing 4 Temperature (engine)
1161	Main Bearing 5 Temperature (engine)
1162	Main Bearing 6 Temperature (engine)
1163	Main Bearing 7 Temperature (engine)
1164	Main Bearing 8 Temperature (engine)
1165	Main Bearing 9 Temperature (engine)
1166	Main Bearing 10 Temperature (engine)
1167	Main Bearing 11 Temperature (engine)
1172	Turbocharger 1 Compressor Inlet Temperature
1173	Turbocharger 2 Compressor Inlet Temperature
1174	Turbocharger 3 Compressor Inlet Temperature
1175	Turbocharger 4 Compressor Inlet Temperature
1180	Turbocharger 1 Turbine Inlet Temperature
1181	Turbocharger 2 Turbine Inlet Temperature
1182	Turbocharger 3 Turbine Inlet Temperature
1183	Turbocharger 4 Turbine Inlet Temperature
1184	Turbocharger 1 Turbine Outlet Temperature

(continued)

(Table 16, contd)

SPNs Available for Configuration of Temperature Inputs	
SPN	Description
1185	Turbocharger 2 Turbine Outlet Temperature
1186	Turbocharger 3 Turbine Outlet Temperature
1187	Turbocharger 4 Turbine Outlet Temperature
1212	Engine Auxiliary Coolant Temperature
1800	Battery 1 Temperature
1801	Battery 2 Temperature
1802	Intake Manifold 5 Temperature
1803	Intake Manifold 6 Temperature
2433	Right Manifold Exhaust Gas Temperature
2434	Left Manifold Exhaust Gas Temperature

## Configuration

- The Thermocouple Module will remain fully functional during single setpoint configuration and also during communications on the data link
- Even if the communication link is terminated, the Thermocouple Module will continue to operate normally
- All configured values and error codes are stored in non-volatile memory allowing retention of all parameter values and error codes when the Thermocouple Module is de-energized
- The Thermocouple Module is configured on the optional data link (CAN2) by using the Caterpillar service tool which has the capability to configure any parameter that is programmable or configurable

Table 17 lists the configuration parameters for the thermocouple inputs.

Table 17

Thermocouple Input Configuration parameters		
Description	Default Value	Range
Input #n – Suspect Parameter Number (SPN)	0	Any SPN listed in Table 16
Input #n - Type	Not Installed	Not Installed Type-J Type-K
Input #n – High Temperature Shutdown Threshold	95	0 to 1735 Celsius
Input #n – High Temperature Warning Threshold	85	0 to 1735 Celsius
Input #n – Low Temperature Warning Threshold	-200	-200 to 800 Celsius
Input #n – High Temperature Shutdown Delay Time	1	0 to 120 seconds
Input #n – High Temperature Warning Delay Time	1	0 to 120 seconds
Input #n – Low Temperature Warning Delay Time	1	0 to 120 seconds

## Specifications

Table 18 lists the specifications for the Thermocouple Module.

Table 18

Thermocouple Module Specifications	
Valid Thermocouple Types	Type-J and Type-K
Operating Voltage Range	9 VDC to 32 VDC
Nominal Voltage Range	12 VDC to 24 VDC
Overvoltage Capability	32 VDC for one hour at 85 °C (185 °F)
Ambient Storage Temperature	-50 °C (-58 °F) to 125 °C (257 °F)
Ambient Operating Temperature Range	-40 °C (-40 °F) to 120 °C (248 °F) (see notes)

**Note:** If the ambient temperature exceeds 85 °C (185 °F), then the Thermocouple Module may deviate in accuracy +/- 1° C

**Note:** If the ambient temperature exceeds 120 °C (248 °F), then the Thermocouple Module may not return to proper operation

i02428620

Table 20

## Discrete Input/Output Module

SMCS Code: 7490

### [ OPTIONAL USE ]

This module is not required.

### General Information

The Discrete Input/Output (I/O) Module is a device that is capable of reading twelve discrete inputs and operating eight relay outputs. The Discrete I/O Module can be mounted on the genset package or else the module can be mounted remotely away from the genset package.

### Inputs

The Discrete I/O Module has twelve inputs with four return channels. The inputs can be activated by either switching to a return or by switching to battery negative. Each of the inputs can be configured to signal one of many possible events. The Caterpillar Service Tool is used in order to configure the Discrete I/O Module inputs.

Inputs that generate a warning message will reset automatically whenever the input returns to a non-active state. Inputs that generate a shutdown message will continue until the input returns to a non-active state and a reset message is received on the J1939 Data Link.

The input configuration parameters are shown in Table 19.

Table 19

Configuration Parameters for Each Input		
Setpoint Parameter	Range	Default
Input #nn Active State Configuration	Active Low Active High	Active State Low
Input #nn Time Delay	0 to 120 seconds	0
Input #nn Suspect parameter Number (SPN)	Any SPN (see Table 20 supported by EMCP 3)	N/A
Input #nn Failure Mode Identifier (FMI)	Any FMI supported by EMCP 3	N/A

Table 20 lists the Suspect Parameter Numbers (SPN) that the EMCP 3 supports for inputs and outputs. An SPN is an internationally recognized trouble code that is assigned a specific meaning. For example, SPN 110 relates to the Engine Coolant Temperature.

EMCP 3 Supported Suspect Parameter Numbers			
SPN	SPN Description	Input	Output
38	Fuel Level-Secondary Tank	X	X
52	Engine Aftercooler Temperature		X
82	Starting Air Pressure		X
94	Fuel Pressure		X
95	Fuel Filter Differential Pressure		X
96	Fuel Level (Primary Tank)	X	X
98	Engine Oil Level		X
99	Oil Filter Differential Pressure		X
100	Engine Oil Pressure		X
101	Crankcase Pressure		X
107	Air Filter Differential Pressure		X
110	Engine Coolant Temperature		X
111	Engine Coolant Level	X	X
137	Extinguisher System Pressure	X	X
167	Battery Charging System Voltage	X	X
168	Battery Voltage		X
171	Ambient Air Temperature		X
172	Inlet Air Temperature		X
173	Exhaust Temperature		X
174	Fuel Temperature		X
175	Engine Oil Temperature		X
190	Engine Overspeed		X
612	Gen Rotating Diode Failure		X
628	Voltage Regulator Failure		X
970	Emergency Stop Shutdown <sup>(1)</sup>		X
971	Engine Derate Overridden		X
1084	Gen Overexcitation	X	X
1122	Generator Bearing Temperature #1		X

(continued)

(Table 20, contd)

EMCP 3 Supported Suspect Parameter Numbers			
SPN	SPN Description	Input	Output
1124	Generator Winding Temperature #1		X
1125	Generator Winding Temperature #2		X
1126	Generator Winding Temperature #3		X
1237	Emergency Shutdown Override Mode Active Warning	X	X
1239	Ruptured Fuel Basin-Primary Tank	X	X
1383	Unexpected Engine Shutdown		x
1664	Engine Failure to Start Shutdown		X
2433	Right Exhaust Temperature		X
2434	Left Exhaust Temperature		X
2436	Generator Frequency		X
2440	Generator Voltage		X
2448	Generator AC Current		X
2452	Generator Reverse Power (kW)		X
2456	Generator Reactive Power (VAR)		X
2648	Service Interval Warning		X
4000	Air Shutoff Damper Close	X	X
4001	ATS in Normal Position	X	X
4002	ATS in Emergency Position	X	X
4003	Battery Charger Failure	X	X
4004	Gen Breaker Closed	X	X
4005	Utility Breaker Closed	X	X
4006	Engine in Cooldown		X
4007	Generator Control Not in Auto		X
4028	Earth Fault	X	X
4029	Earth Leakage	X	X
User Defined Input #1	Range 701-716	X	

(continued)

(Table 20, contd)

EMCP 3 Supported Suspect Parameter Numbers			
SPN	SPN Description	Input	Output
User Defined Input #2	Range 701-716	X	
User Defined Input #3	Range 701-716	X	
User Defined Input #4	Range 701-716	X	
User Defined Input #5	Range 701-716	X	
User Defined Input #6	Range 701-716	X	
User Defined Input #7	Range 701-716	X	
User Defined Input #8	Range 701-716	X	
User Defined Input #9	Range 701-716	X	
User Defined Input #10	Range 701-716	X	
User Defined Input #11	Range 701-716	X	
User Defined Input #12	Range 701-716	X	

(1) Input configured as "Emergency Stop Shutdown" (SPN 970) will not perform a shutdown when activated. Use only to create an event log message in the EMCP 3 if desired.

## Outputs

The Discrete I/O Module has eight "Form C" relay outputs. Each output can be configured to signal one of many possible events. Each output can be configured for either general events or for specific events. The Caterpillar Service Tool, which has the capability to configure any configurable or programmable parameter, is used in order to configure the Discrete I/O Module outputs.

For **general** events, each output activates whenever any "Alarm Condition", "Shutdown Condition", or any combination of the two conditions exist.

For **specific** events, each output activates whenever the diagnostic message contains the SPN and Failure Mode Identifier (FMI) combination that matches the SPN and FMI combination that is programmed for that particular output.

The FMI defines the nature of the event, such as above range or below range. This includes events such as High or Low alarms, Shutdowns, or Condition Exists.

The output configuration parameters are shown in table 21.

Table 21

Configuration Parameters for Each Output	
Setpoint Parameter	Range
Output #nn SPN	Any SPN supported by EMCP 3
Output #nn Trigger Condition	<p>Disabled</p> <p>Specific    Condition Exists Diagnostic High Shutdown High Warning Low Shutdown Low Warning Warning or Shutdown Warning, Shutdown, or Diagnostic</p> <p>General    Diagnostic Shutdown Warning Warning, Shutdown, or Diagnostic</p>

### Configuration Behaviors

The Discrete I/O Module exhibits the following configuration behaviors.

- Maintains functionality with no loss in performance during single setpoint configuration
- Maintains functionality with no loss in performance while communicating on the data link
- Retains all configured values in non-volatile memory
- Configured on the optional module data link (CAN2) using the Caterpillar service tool

### Specifications

Table 22 lists the specifications for the Input/Output Module.

Table 22

Input/Output Module Specifications	
Operating Voltage Range	12 VDC 24 VDC (external power supplies)
Nominal Voltage	9 VDC to 32 VDC
Ambient Operating Temperature	-40 degrees Celsius to 70 degrees Celsius
Output Relay Contact Ratings	5A @ 120 VAC 5A @ 30 VDC 2A @ 277 VAC

i02430664

## Resistive Temperature Device Module

SMCS Code: 7490

### [ OPTIONAL USE ]

This module is not required.

### General Information

The resistance of a given material changes as the temperature of the material changes. A Resistive Temperature Device (RTD) uses this principle in order to accurately measure temperature. An RTD is a passive device that requires an external excitation current. Once the current is supplied to the RTD, the voltage is read across the RTDs terminals and converted into a temperature using a simple mathematical algorithm.

Although RTDs are more costly than Thermocouples, they are widely used because of their excellent stability. Additionally, RTDs exhibit the most linear signal with respect to temperature of any electronic temperature sensor. The typical metallic elements used in RTDs are nickel, copper, and platinum. Platinum is one of the more commonly used metals in RTDs because of its wide temperature range, accuracy, and stability.

### Module Overview

The RTD Module is a temperature scanner that is capable of reading eight platinum RTD inputs. The eight platinum RTD inputs can have two, three, or four-wire configurations. The four-wire is the most accurate because it uses one pair of wires for the excitation current and a separate pair of wires to measure the voltage.

The RTD Module will read the inputs, apply the algorithm, and then calculate the temperature in "Celsius". The RTD Module will then broadcast the information onto the J1939 data link. The Engine Control Module (ECM) for the generator set will read the information from the RTD Module and display the information on the display screen.

The RTD Module is also capable of generating diagnostics. The diagnostics that are generated by the RTD Module are maintained in non-volatile memory in order to ensure that they are available following a power loss.

## Diagnostics

The RTD Module is capable of storing the twenty diagnostic log entries that can be viewed from the ECM and that are broadcast on the J1939 Data Link.

Each of the eight inputs have sensor diagnostics in order to detect open or short circuits that go to the RTD sensors. Overtemperature warnings and Shutdowns, as well as Undertemperature warnings, are detected by comparing the measured temperature to the Low Warning, the High Warning, and the High Shutdown temperatures that are stored in the module. The ECM reads these messages and annunciates and/or performs engine shutdown appropriately. Any of the inputs can be disabled in order to prevent unnecessary diagnostic faults.

Table 23 shows the format for the log entries.

Table 23

Diagnostic Log Entry Format Table
Suspect Parameter Number (SPN) <sup>(1)</sup>
Failure Mode Indicator (FMI) <sup>(2)</sup>
Time of Last Occurrence
Date of Last Occurrence
Time of First Occurrence
Date of First Occurrence
Engine Run Hours First Occurrence
Engine Run Hours Last Occurrence
Number of Occurrences
Security to Clear Log Entry

(1) See Table 25 for possible code numbers.

(2) See Table 24 for possible code numbers.

Table 24 shows the RTD Module diagnostics.

Table 24

RTD Module Diagnostics - FMI Codes	
FMI	Description
0	RTD Input #n High Temperature Shutdown
4	RTD Input Sensor #n Short Circuit
5	RTD Input Sensor #n Open Circuit
15	RTD Input #n High Temperature Warning
17	RTD Input #n Low Temperature Warning

## Monitoring Features

The RTD Module monitors eight Platinum RTD inputs. All monitored values are available on the communication data link as read-only information. Temperatures are configured in order to indicate the SAE J1939 Suspect Parameter Number (SPN) transmitted by each temperature input. An SPN is an internationally recognized trouble code that is assigned a specific meaning. For example, SPN 171 relates to the Ambient Air Temperature.

Each input is fully configurable and can be set to any SPN that is listed in Table 25. The display units are selectable at the "EMCP 3" controller as either Fahrenheit or Celsius. The Caterpillar service tool, which has the capability to configure any configurable or programmable parameter, is used in order to configure the inputs of the RTD module.

Table 25 shows the SPNs that are available for configuration of temperature inputs.

Table 25

SPNs Available for Configuration of Temperature Inputs	
SPN	Description
52	Engine Intercooler Temperature
105	Intake Manifold 1 Temperature
110	Engine Coolant Temperature
171	Ambient Air Temperature
172	Air Inlet Temperature
173	Exhaust Gas Temperature
174	Fuel Temperature
175	Engine Oil Temperature 1
176	Turbo Oil Temperature
441	Auxiliary Temperature 1
442	Auxiliary Temperature 2
1122	Alternator Bearing 1 Temperature

(continued)

(Table 25, contd)

SPNs Available for Configuration of Temperature Inputs	
SPN	Description
1123	Alternator Bearing 2 Temperature
1124	Alternator Winding 1 Temperature
1125	Alternator Winding 2 Temperature
1126	Alternator Winding 3 Temperature
1131	Intake Manifold 2 Temperature
1132	Intake Manifold 3 Temperature
1133	Intake Manifold 4 Temperature
1135	Engine Oil Temperature 2
1137	Exhaust Gas Port 1 Temperature
1138	Exhaust Gas Port 2 Temperature
1139	Exhaust Gas Port 3 Temperature
1140	Exhaust Gas Port 4 Temperature
1141	Exhaust Gas Port 5 Temperature
1142	Exhaust Gas Port 6 Temperature
1143	Exhaust Gas Port 7 Temperature
1144	Exhaust Gas Port 8 Temperature
1145	Exhaust Gas Port 9 Temperature
1146	Exhaust Gas Port 10 Temperature
1147	Exhaust Gas Port 11 Temperature
1148	Exhaust Gas Port 12 Temperature
1149	Exhaust Gas Port 13 Temperature
1150	Exhaust Gas Port 14 Temperature
1151	Exhaust Gas Port 15 Temperature
1152	Exhaust Gas Port 16 Temperature
1153	Exhaust Gas Port 17 Temperature
1154	Exhaust Gas Port 18 Temperature
1155	Exhaust Gas Port 19 Temperature
1156	Exhaust Gas Port 20 Temperature
1157	Main Bearing 1 Temperature (engine)
1158	Main Bearing 2 Temperature (engine)
1159	Main Bearing 3 Temperature (engine)
1160	Main Bearing 4 Temperature (engine)
1161	Main Bearing 5 Temperature (engine)
1162	Main Bearing 6 Temperature (engine)
1163	Main Bearing 7 Temperature (engine)
1164	Main Bearing 8 Temperature (engine)
1165	Main Bearing 9 Temperature (engine)

(continued)

(Table 25, contd)

SPNs Available for Configuration of Temperature Inputs	
SPN	Description
1166	Main Bearing 10 Temperature (engine)
1167	Main Bearing 11 Temperature (engine)
1172	Turbocharger 1 Compressor Inlet Temperature
1173	Turbocharger 2 Compressor Inlet Temperature
1174	Turbocharger 3 Compressor Inlet Temperature
1175	Turbocharger 4 Compressor Inlet Temperature
1180	Turbocharger 1 Turbine Inlet Temperature
1181	Turbocharger 2 Turbine Inlet Temperature
1182	Turbocharger 3 Turbine Inlet Temperature
1183	Turbocharger 4 Turbine Inlet Temperature
1184	Turbocharger 1 Turbine Outlet Temperature
1185	Turbocharger 2 Turbine Outlet Temperature
1186	Turbocharger 3 Turbine Outlet Temperature
1187	Turbocharger 4 Turbine Outlet Temperature
1212	Engine Auxiliary Coolant Temperature
1800	Battery 1 Temperature
1801	Battery 2 Temperature
1802	Intake Manifold 5 Temperature
1803	Intake Manifold 6 Temperature
2433	Right Manifold Exhaust Gas Temperature
2434	Left Manifold Exhaust Gas Temperature

## Configuration Behaviors

The RTD module exhibits the following configuration behaviors:

- Maintains functionality with no loss in performance during single setpoint configuration
- Maintains functionality with no loss in performance during communications on the data link
- Will continue to operate normally if the communication data link is terminated
- Retains all configured values in nonvolatile memory so that no information is lost when the module is de-energized
- Configured on the optional data link (CAN 2) using the Caterpillar service tool

Each RTD's input has the configuration parameters that are shown in Table 26.

Table 26

Configuration Parameters for Each Input		
Description	Default Value	Range
Input #n – Suspect Parameter Number (SPN)	0	Any SPN that is listed in Table 25
Input #n - RTD Temperature Coefficient Configuration	IEC	IEC Platinum (0.00385) JIS Platinum (0.003916) US Platinum (0.003902) Legacy US Platinum (0.003920) SAMA Platinum (0.003923)
Input #n – RTD Sensor Type	Not Installed	Not Installed 2-wire RTD 3-wire RTD 4-wire RTD
Input #n – High Temperature Shutdown Threshold	95	0 to 1735 °C
Input #n – High Temperature Warning Threshold	85	0 to 1735 °C
Input #n – Low Temperature Warning Threshold	-200	-200 to 800 °C
Input #n – High Temperature Shutdown Delay Time	1	0 to 120 seconds
Input #n – High Temperature Warning Delay Time	1	0 to 120 seconds
Input #n - Low Temperature Warning Delay Time	1	0 to 120 seconds

## Specifications

Table 27

RTD Specifications	
Operating voltage range	9 VDC to 32 VDC
Nominal voltage	12 VDC to 24 VDC
Overvoltage capability	32 VDC for one hour at 85 °C (185 °F)
Ambient storage temperature	-50 °C (-58 °F) to 125 °C (257 °F)
Ambient operating temperature range (see notes)	-40 °C (-40 °F) to 120 °C (248 °F)

**Note:** If the ambient temperatures exceed 85 °C (185 °F), the RTD Module may deviate in accuracy +/- 1°C

**Note:** If the ambient temperature exceeds 120 °C (248 °F), the RTD Module may not return to proper operation.

i02448845

## Annunciator Module

**SMCS Code:** 4490

### [ OPTIONAL USE ]

This module is not required.

## General Information

The EMCP 3 Annunciator Module is used in order to indicate various system events and status conditions. The Annunciator Module uses indicator lights and an audible horn in order to provide the operator with information about the current status of the system. The Annunciator Module can be used in order to announce faults and status signals to the operator. The Annunciator Module also allows the operator to silence the horn or to acknowledge the system faults.

There are seventeen pairs of LED indicators on the annunciator's front panel. Sixteen of these indicator pairs are used in order to announce events, diagnostics, and ready signals. The seventeenth indicator pair is used as a combined network and module status LED to alert the operator of problems with the J1939 data link connection.

Table 28 lists the color scheme associated with the data link connections status LEDs.

Table 28

J1939 Data Link Connection Status LEDs	
Solid Green	Data link is OK
Flashing Green	Data on link is corrupted
Yellow	Data link is disconnected

## Basic Operation

Each pair of LED indicators on the annunciator consist of two of the following three colors: green, yellow, and red. The color choices allow for custom configuration of Status, Warning, and Shutdown indicators. For example, a pair of red and yellow LED indicators may be configured for Engine Oil Pressure. If a low engine oil pressure Warning is read over the data link, the Annunciator will flash the Yellow LED and the audible horn will sound. If the low engine oil pressure Shutdown is read over the data link, the Annunciator will flash the Red LED and the audible horn will sound.

In order to acknowledge the Shutdown and Alarm conditions or to silence the horn, press the **Alarm Acknowledge** button that is located near the middle of the annunciator.

In order to test the LED indicators, or in order to test the horn when the data link is connected or disconnected, depress and hold the **Lamp Test** button that is located near the top of the Annunciator.

Table 29 lists the available color combinations for the seventeen pairs of LEDs that are on the annunciator.

Table 29

Alarm Conditions and System Status LED Color Combinations		
Row	LED 1	LED 2
1	Red	Yellow
2	Red	Yellow
3	Red	Yellow
4	Red	Yellow
5	Red	Yellow
6	Red	Yellow
7	Red	Yellow
8	Red	Yellow
8	Red	Yellow
9	Red	Yellow
11	Red	Yellow
12	Red	Yellow
13	Green	Yellow
14	Green	Yellow
15	Red	Green
16	Red	Green
17	Yellow	Green

## Configuration

The Annunciator Module can be customized in order to signal many different system related conditions. The supported data link parameters are shown in Table 30 in the form of J1939 Suspect Parameter Numbers (SPNs).

The service tool must be used in order to configure each LED pair. Once the service tool has been connected to the Annunciator, the user enters the "Configuration" screen in order to customize the LED pairs for the system related condition. Each LED pair has four settings: SPN, Trigger Type, Trigger Severity Level, and Failure Mode Identifier (FMI).

## Custom Event Annunciation

The annunciator can be configured for any event (SPN and FMI combination) that is listed in tables 30 and 31. For custom events, those that are not listed on the standard film, the user has two options. Either a descriptive label may be placed next to the appropriate LED pair after the LEDs have been configured, or else the standard film may be replaced with a label from the 260-6898 Custom Label Kit.

Custom events originating from sensing devices that do not communicate on the J1939 Data Link need either to have their dry contacts wired to EMCP 3 spare digital inputs or else they need to be wired to an unused input on the optional Discrete I/O Module.

**Reference:** For information on programming EMCP 3 spare digital inputs, see System Operation, "Digital Input Programming"

**Reference:** For information on programming the Discrete I/O Module, see System Operation, "Discrete Input/Output Module"

### Suspect Parameter Number (SPN)

Choose the SPN from Table 30.

### Trigger Type

The Trigger Type may be set as Disabled, General Event, or Specific Event.

**Disabled** – Disabling the Trigger Type disables the LED pair. When disabled, the LED pair will not respond to any data link message.

**General Event** – If General Event is chosen, the SPN does not matter. General Event is used when it is desired that the LED pair illuminate for any Warning, Shutdown, High, or Low alarm.

**Specific Event** – Specific Event is used when the LED pair is to be associated with a specific system parameter such as oil pressure or coolant temperature.

### Trigger Severity Level

The Trigger Severity Level defines how the LED pair will behave when a message associated with the programmed SPN is received (or not received).

Table 30

Supported SPNs	
SPN Description	SPN
Fuel Level (External Tank)	38
Aftercooler Temperature	52
Starting Air Pressure	82
Fuel Filter Differential Pressure	95
Fuel Level (Local Tank)	96
Engine Oil Level	98
Oil Filter Differential Pressure	99
Engine Oil Pressure	100

(continued)

(Table 30, contd)

Supported SPNs	
SPN Description	SPN
Crankcase Pressure	101
Air Filter Differential Pressure	107
Atmospheric Pressure	108
Engine Coolant Temperature	110
Engine Coolant Level	111
Fire Extinguisher Pressure	137
Battery Voltage (switched)	158
Battery Voltage	168
Ambient Air Temperature	171
Inlet Air Temperature	172
Exhaust Temperature	173
Engine Oil Temperature	175
Engine Speed	190
SCADA Data Link Fault	625
Primary Data Link (J1939 #1)	639
Event Input Function #1	701
Event Input Function #2	702
Event Input Function #3	703
Event Input Function #4	704
Event Input Function #5	705
Event Input Function #6	706
Event Input Function #7	707
Event Input Function #8	708
Event Input Function #9	709
Event Input Function #10	710
Event Input Function #11	711
Event Input Function #12	712
Event Input Function #13	713
Event Input Function #14	714
Event Input Function #15	715
Event Input Function #16	716
Emergency Stop Shutdown	970
Generator Bearing Temperature #1	1122
Generator Bearing Temperature #2	1123
Generator Winding Temperature #1	1124
Generator Winding Temperature #2	1125
Generator Winding Temperature #3	1126

(continued)

(Table 30, contd)

Supported SPNs	
SPN Description	SPN
Exhaust Gas Port 1 Temperature	1137
Exhaust Gas Port 2 Temperature	1138
Exhaust Gas Port 3 Temperature	1139
Exhaust Gas Port 4 Temperature	1140
Exhaust Gas Port 5 Temperature	1141
Exhaust Gas Port 6 Temperature	1142
Exhaust Gas Port 7 Temperature	1143
Exhaust Gas Port 8 Temperature	1144
Exhaust Gas Port 9 Temperature	1145
Exhaust Gas Port 10 Temperature	1146
Exhaust Gas Port 11 Temperature	1147
Exhaust Gas Port 12 Temperature	1148
Exhaust Gas Port 13 Temperature	1149
Exhaust Gas Port 14 Temperature	1150
Exhaust Gas Port 15 Temperature	1151
Exhaust Gas Port 16 Temperature	1152
Exhaust Gas Port 17 Temperature	1153
Exhaust Gas Port 18 Temperature	1154
Exhaust Gas Port 19 Temperature	1155
Exhaust Gas Port 20 Temperature	1156
Accessory Data Link Fault (J1939 #2)	1231
Emergency Shutdown Override Mode Active Warning	1237
Ruptured Fuel Basin - Primary Tank	1239
Unexpected Engine Shutdown	1383
Engine Failure to Start Shutdown	1664
Right Exhaust Temperature	2433
Left Exhaust Temperature	2434
Generator Frequency	2436
Generator AC Voltage	2440
Generator AC Current	2448
Generator Reverse Power (kW)	2452
Generator Reverse Power (kVAr)	2456
Service Interval Warning	2648
Air Damper Closed	4000
ATS in Normal Position	4001
ATS in Emergency Position	4002
Battery Charger Failure	4003

(continued)

(Table 30, contd)

Supported SPNs	
SPN Description	SPN
Generator Control Not in Automatic Warning	4007
Generator Breaker Failure to Open	4009
Utility Breaker Failure to Open	4010
Generator Breaker Failure to Close	4011
Utility Breaker Failure to Close	4012
Utility to Generator Transfer Failure Warning	4015
Generator to Utility Transfer Failure Warning	4016
Loss of Utility	4017

**Failure Mode Identifier (FMI)**

Choose the FMI from Table 31.

Table 31

<b>Failure Mode Identifier (FMI) Codes</b>		
<b>FMI</b>	<b>Description</b>	<b>Short Description</b>
0	Data Valid but Above Normal Operational Range - Most Severe Level	High Shutdown
1	Data Valid but Below Normal Operational Range - Most Severe Level	Low Shutdown
2	Data Erratic, Intermittent or Incorrect	N/A
3	Voltage Above Normal or Shorted to High Source	N/A
4	Voltage Below Normal or Shorted to Low Source	N/A
5	Current Below Normal or Grounded Circuit	N/A
6	Current Above Normal or Grounded Circuit	N/A
7	Mechanical System Not Responding or Out of Adjustment	N/A
8	Abnormal Frequency, Pulse Width or Period	N/A
9	Abnormal Update Rate	N/A
10	Abnormal Rate of Change	N/A
11	Unexpected Engine Shutdown	N/A
12	Bad Intelligent Device or Component	N/A
13	Out of Calibration	N/A
14	Special Instructions	N/A
15	Data Valid But Above Normal Operating Range - Least Severe Level	High Warning
16	Data Valid But Above Normal Operating Range - Moderately Severe Level (Derate)	High Warning
17	Data Valid But Below Normal Operating Range - Least Severe Level	Low Warning
18	Data Valid But Below Normal Operating Range - Moderately Severe Level (Derate)	Low Warning
19	Received Network Data In Error	N/A
31	Not Available or Condition Exists	Status

## **Adding Additional Remote Annunciator**

An additional remote annunciator may be added if desired. In order to operate properly, the annunciator must be located within 244 m (800) of the EMCP 3 and the end of line terminating resistor must be relocated. Refer to Illustration 12.

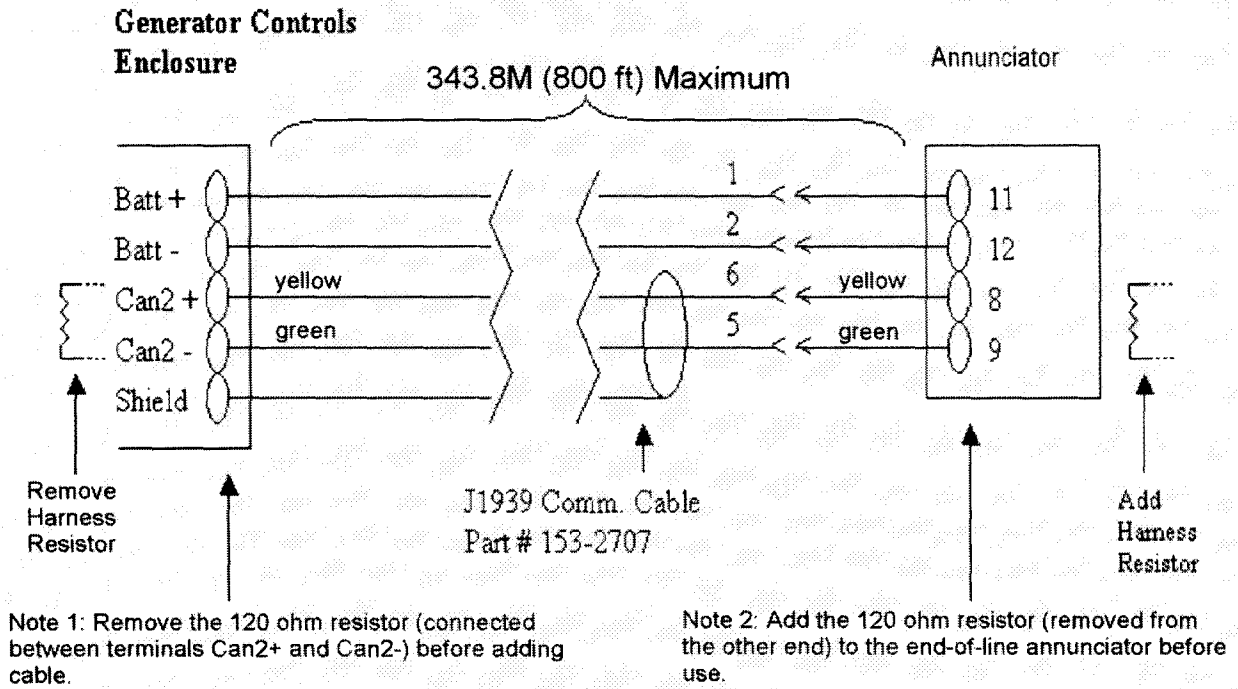

Illustration 12

g01093231

Adding additional remote annunciator

Additional modules may be added in parallel to remote annunciators. In order to operate properly, the device to be added in parallel to the annunciator must not have cable drop lengths greater than 2.7 m (9 ft.). Refer to Illustration 13.

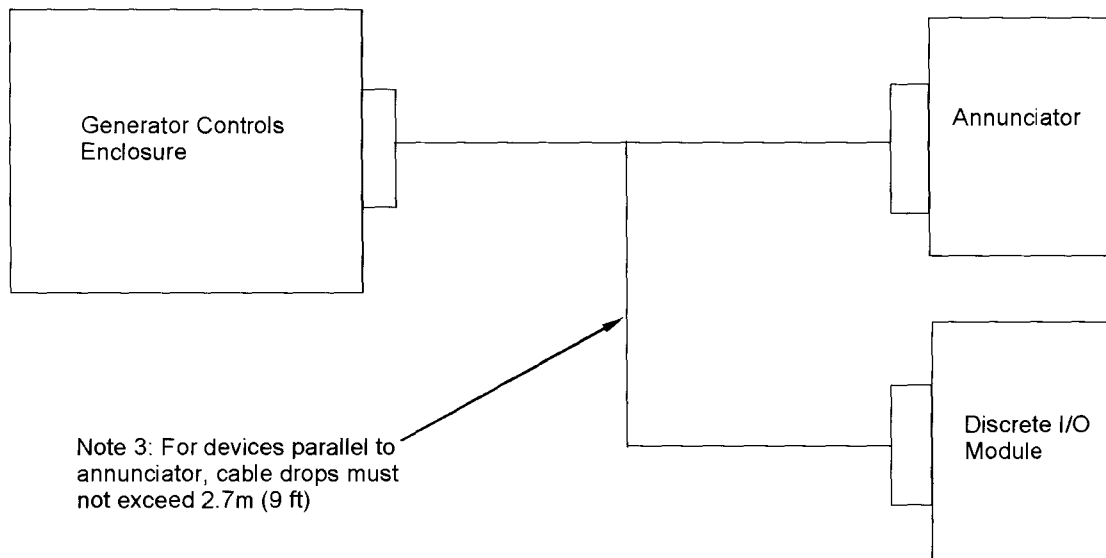

Illustration 13

g01093228

Connection details for devices in parallel with remote annunciator

# Troubleshooting Section

## Introduction

i02464576

## General Information

SMCS Code: 4490

### WARNING

Personal injury or death can result from high voltage.

When power generation equipment must be in operation to make tests and/or adjustments, high voltage and current are present.

Improper test equipment can fail and present a high voltage shock hazard to its user.

Make sure the testing equipment is designed for and correctly operated for high voltage and current tests being made.

When servicing or repairing electric power generation equipment:

- Make sure the unit is off-line (disconnected from utility and/or other generators power service) , and either locked out or tagged **DO NOT OPERATE**.
- Remove all fuses.
- Make sure the generator engine is stopped.
- Make sure all batteries are disconnected.
- Make sure all capacitors are discharged.

Failure to do so could result in personal injury or death. Make sure residual voltage in the rotor, stator and the generator is discharged.

### WARNING

When the engine-generator, or any source to which the engine-generator is synchronized to, is operating, voltages up to 600V are present in the control panel.

Do not short these terminal with line voltage to ground with any part of the body or any conductive material. Loss of life or injury could result from electrical shock or injury from molten metal.

### WARNING

Do not connect generator to a utility electrical distribution system unless it is isolated from the system. Electrical feedback into the distribution system can occur and could cause personal injury or death.

Open and secure main distribution system switch, or if the connection is permanent, install a double throw transfer switch to prevent electrical feedback. Some generators are specifically approved by a utility to run in parallel with the distribution system and isolation may not be required. Always check with your utility as to the applicable circumstances.

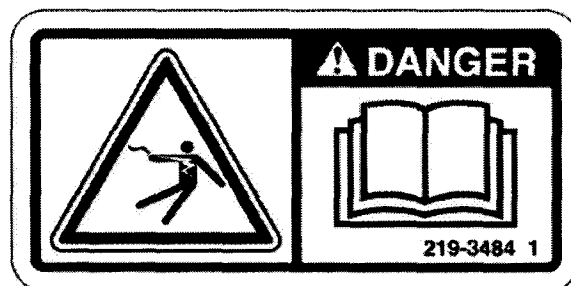

Illustration 14

g00891948

Danger Label for Electrical Shock (North America)

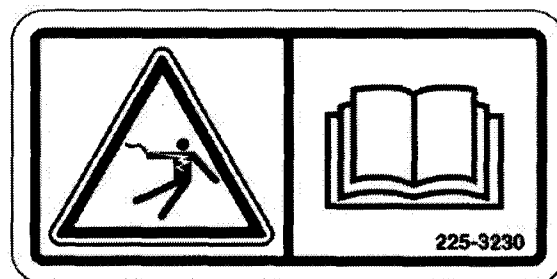

Illustration 15

g00874165

Danger Label for Electrical Shock (Outside of North America)

**⚠ DANGER**

The Cat VR6 presents an electrical shock/electrocution hazard. This hazard will cause serious injury or death.

Service by trained personnel only.

The terminals and heat sinks are live at hazardous voltages when power is applied and for up to 8 minutes after power is removed.

**⚠ DANGER**

The Cat Digital Voltage Regulator presents an electrical shock/electrocution hazard. This hazard will cause serious injury or death.

Service by trained personnel only.

The terminals and heat sinks are live at hazardous voltages when power is applied and for up to 8 minutes after power is removed.

**⚠ DANGER**

The secondary wires of the current transformer must be shorted together when they are disconnected from the equipment. Extremely high voltages will be generated at the lead ends if the secondary wires are not shorted together. Bodily contact with high voltage will result in serious injury or death.

## Service Tools

SMCS Code: 0785

Table 32

Genset Diagnostic Tools	
190-8900	Deutsch HD Style Connector Repair Kit. Replaces 4C-3406 Repair Kit and does not contain 1U5804 Crimp Tool that can be ordered separately if needed.
6V-3000	Sure Seal Repair Kit
175-3700	Deutsch DT Style Connector Repair Kit.
	4 mm Hex Wrench
237-5130	Digital Multimeter with infrared thermometer
257-9140	Fluke 80 Series Digital Multimeter
146-4080	Digital Multimeter with RS232 output
7X-1710	Multimeter Connector Probe Group
155-5175	1000 Amp AC Current Probe for use with digital multimeters
155-5176	1000 Amp AC / 1400 Amp DC Current Probe for use with digital multimeters
243-3134	Insulation Tester
255-8266	1200 Amp AC/DC Clamp On Ammeter
227-4324	2000 Amp AC/DC clamp On Ammeter

i02461489

## Diagnostic Capabilities

SMCS Code: 1400

### The Caterpillar Electronic Technician

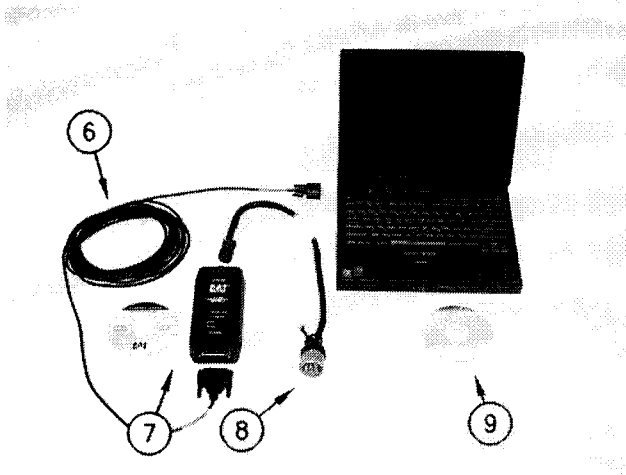

Illustration 16

g00774942

Connections for the Communication Adapter II and the Caterpillar Electronic Technician

The components that are needed in order to use the Communication Adapter II and the Caterpillar Electronic Technician in order to determine diagnostic codes are listed:

- (6) Cable
- (7) 171 - 4400 Communication Adapter ii
- (8) Service diagnostic cable.
- (9) Current version of Caterpillar Electronic Technician software and an IBM-COMPATIBLE personal computer

The Caterpillar Electronic Technician is a software program that is used as a service tool in order to access data. The service technician can use this service tool in order to perform maintenance on the machine. Some of the options that are available with the Caterpillar Electronic Technician are listed below:

- View diagnostic codes.
- Viewing active event codes and logged event codes
- View the status of parameters.
- Clear active diagnostic codes and clear logged diagnostic codes
- Program the ECM (Flash). This is done with the "WINflash" program. See Testing and Adjusting, "Electronic Control Module (Generator Set) - Flash Program".

- Print reports.

The following list contains some of the diagnostic functions and programming functions that are performed by the service tools.

- The failures of the ECM system are displayed.
- The status of most of the inputs and the outputs are displayed.
- The settings for the ECM are displayed.
- Display the status of the input and output parameters in real time.
- Display the clock hour of the internal diagnostic clock.
- The number of occurrences and the clock hour of the first occurrence and the last occurrence is displayed for each logged diagnostic code.
- The definition for each logged diagnostic code and each event is displayed.
- Load new FLASH software.

See Troubleshooting, "Diagnostic Trouble Code List" for the list of diagnostic codes for the ECM.

- Active diagnostic codes
- Logged diagnostic codes

### Event Codes

#### Logged Event Codes

An indicator for logged events is provided. The indicator allows the service technician to keep track of event codes that are intermittent. The data for the logged event will include the following information:

- An event identifier
- A text description of the problem
- The number of occurrences of the problem
- A time stamp will display the first occurrence of the problem.
- A time stamp will display the last occurrence of the problem.

### Status Groups For The Caterpillar Electronic Technician

The Status Groups are lists of ECM parameters. The status of the parameters are shown in real time.

i02422646

## Diagnostic Trouble Code List

**SMCS Code:** 7569

**Reference:** For a full explanation of the use of the Enter function key referenced in this section, see Systems Operation, "Electronic Control Module (Generator Set)"

Table 33 lists the diagnostic trouble codes for the genset. The column titled "Display Text String" is the information that is displayed on the EMCP 3 control panel. In order to view the Suspect Parameter Number (SPN) and the Failure Mode Identifier (FMI), press the Enter Key while viewing the Display Text String.

If the diagnostic code was generated from the Electronic Control Module (ECM) for the engine, refer to the Systems Operation, Testing and Adjusting manual for your particular engine and perform the diagnostic procedure indicated by the SPN/FMI.

If the diagnostic code is generated from the EMCP 3 Electronic Control Module for the generator set, refer to the last column of the following table and reference the " Troubleshooting Topic", within this section.

**Note:** The Emergency Shutdown Override Mode Active Warning requires a level 3 password in order to clear the code. All remaining listed codes require a level 1 password in order to clear the code.

Table 33

Trouble Codes				
Suspect Parameter Number (SPN)	Failure Mode Identifier (FMI)	Code Description	Display Text String	Troubleshooting topic
38	0	External Tank High Fuel Level Shutdown	EXT TANK HIGH FUEL LEVEL S/D	Digital Input Circuit Fault and Analog Input Circuit Fault
38	1	External Tank Low Fuel Level Shutdown	EXT TANK LOW FUEL LEVEL S/D	Digital Input Circuit Fault and Analog Input Circuit Fault
38	3	External Tank Fuel Level Sensor Short High	EXT TANK FUEL LEVEL SENSOR SHORT HIGH	Analog Input Circuit Fault
38	4	External Tank Fuel Level Sensor Short Low	EXT TANK FUEL LEVEL SENSOR SHORT LOW	Analog Input Circuit Fault
38	15	External Tank High Fuel Level Warning	EXT TANK HIGH FUEL LVL WARNING	Digital Input Circuit Fault and Analog Input Circuit Fault
38	17	External Tank Low Fuel Level Warning	EXT TANK LOW FUEL LVL WARNING	Digital Input Circuit Fault and Analog Input Circuit Fault

(continued)

(Table 33, contd)

Trouble Codes				
Suspect Parameter Number (SPN)	Failure Mode Identifier (FMI)	Code Description	Display Text String	Troubleshooting topic
82	0	High Starting Air Pressure Shutdown	HIGH STARTING AIR PRES SHUTDOWN	Digital Input Circuit Fault and Analog Input Circuit Fault
82	1	Low Starting Air Pressure Shutdown	LOW STARTING AIR PRES SHUTDOWN	Digital Input Circuit Fault and Analog Input Circuit Fault
82	3	Starting Air Pressure Sensor Short High	STARTING AIR PRES SENSOR SHORT HIGH	Analog Input Circuit Fault
82	4	Starting Air Pressure Sensor Short Low	STARTING AIR PRES SENSOR SHORT LOW	Analog Input Circuit Fault
82	15	High Starting Air Pressure Warning	HIGH STARTING AIR PRES WARNING	Digital Input Circuit Fault and Analog Input Circuit Fault
82	17	Low Starting Air Pressure Warning	LOW STARTING AIR PRES WARNING	Digital Input Circuit Fault and Analog Input Circuit Fault
95	0	High Fuel Filter Differential Pressure Shutdown	HIGH FUEL FLTR DIFF PRES SHUTDOWN	Digital Input Circuit Fault and Analog Input Circuit Fault
95	1	Low Fuel Filter Differential Pressure Shutdown	LOW FUEL FILTER DIFF PRES SHUTDOWN	Digital Input Circuit Fault and Analog Input Circuit Fault
95	3	Fuel Filter Differential Pressure Sensor Short High	FUEL FLTR DIFF PRES SENSOR SHORT HIGH	Analog Input Circuit Fault
95	4	Fuel Filter Differential Pressure Sensor Short Low	FUEL FLTR DIFF PRES SENSOR SHORT LOW	Analog Input Circuit Fault
95	15	High Fuel Filter Differential Pressure Warning	HIGH FUEL FLTR DIFF PRES WARNING	Digital Input Circuit Fault and Analog Input Circuit Fault
95	17	Low Fuel Filter Differential Pressure Warning	LOW FUEL FILTER DIFF PRES WARNING	Digital Input Circuit Fault and Analog Input Circuit Fault
96	0	High Fuel Level Shutdown	HIGH FUEL LEVEL SHUTDOWN	Digital Input Circuit Fault and Analog Input Circuit Fault
96	1	Low Fuel Level Shutdown	LOW FUEL LEVEL SHUTDOWN	Digital Input Circuit Fault and Analog Input Circuit Fault
96	3	Fuel Level Sensor Short High	FUEL LEVEL SENSOR SHORT HIGH	Analog Input Circuit Fault
96	4	Fuel Level Sensor Short Low	FUEL LEVEL SENSOR SHORT LOW	Analog Input Circuit Fault
96	15	High Fuel Level Warning	HIGH FUEL LEVEL WARNING	Digital Input Circuit Fault and Analog Input Circuit Fault

(continued)

(Table 33, contd)

<b>Trouble Codes</b>				
<b>Suspect Parameter Number (SPN)</b>	<b>Failure Mode Identifier (FMI)</b>	<b>Code Description</b>	<b>Display Text String</b>	<b>Troubleshooting topic</b>
96	17	Low Fuel Level Warning	LOW FUEL LEVEL WARNING	Digital Input Circuit Fault and Analog Input Circuit Fault
98	0	High Engine Oil Level Shutdown	HIGH ENGINE OIL LVL SHUTDOWN	Digital Input Circuit Fault and Analog Input Circuit Fault
98	1	Low Engine Oil Level Shutdown	LOW ENGINE OIL LVL SHUTDOWN	Digital Input Circuit Fault and Analog Input Circuit Fault
98	3	Engine Oil Level Sensor Short High	ENGINE OIL LEVEL SENSOR SHORT HIGH	Analog Input Circuit Fault
98	4	Engine Oil Level Sensor Short Low	ENGINE OIL LEVEL SENSOR SHORT LOW	Analog Input Circuit Fault
98	15	High Engine Oil Level Warning	HIGH ENGINE OIL LVL WARNING	Digital Input Circuit Fault and Analog Input Circuit Fault
98	17	Low Engine Oil Level Warning	LOW ENGINE OIL LVL WARNING	Digital Input Circuit Fault and Analog Input Circuit Fault
99	0	High Oil Filter Differential Pressure Shutdown	HIGH OIL FILTER DIFF PRES SHUTDOWN	Digital Input Circuit Fault and Analog Input Circuit Fault
99	1	Low Oil Filter Differential Pressure Shutdown	LOW OIL FILTER DIFF PRES SHUTDOWN	Digital Input Circuit Fault and Analog Input Circuit Fault
99	3	Oil Filter Differential Pressure Sensor Short High	OIL FILTER DIFF PRES SENSOR SHORT HIGH	Analog Input Circuit Fault
99	4	Oil Filter Differential Pressure Sensor Short Low	OIL FILTER DIFF PRES SENSOR SHORT LOW	Analog Input Circuit Fault
99	15	High Oil Filter Differential Pressure Warning	HIGH OIL FILTER DIFF PRES WARNING	Digital Input Circuit Fault and Analog Input Circuit Fault
99	17	Low Oil Filter Differential Pressure Warning	LOW OIL FILTER DIFF PRES WARNING	Digital Input Circuit Fault and Analog Input Circuit Fault
100	1	Low Engine Oil Pressure Shutdown	LOW ENGINE OIL PRESS SHUTDOWN	Data Link circuit Fault and Digital Input Circuit Fault
100	17	Low Engine Oil Pressure Warning	LOW ENGINE OIL PRESS WARNING	Data Link circuit Fault and Digital Input Circuit Fault
107	0	High Air Filter Differential Pressure Shutdown	HIGH AIR FILTER DIFF PRES SHUTDOWN	Digital Input Circuit Fault and Analog Input Circuit Fault

(continued)

(Table 33, contd)

Trouble Codes				
Suspect Parameter Number (SPN)	Failure Mode Identifier (FMI)	Code Description	Display Text String	Troubleshooting topic
107	1	Low Air Filter Differential Pressure Shutdown	LOW AIR FILTER DIFF PRES SHUTDOWN	Digital Input Circuit Fault and Analog Input Circuit Fault
107	3	Air Filter Differential Pressure Sensor Short High	AIR FILTER DIFF PRES SENSOR SHORT HIGH	Analog Input Circuit Fault
107	4	Air Filter Differential Pressure Sensor Short Low	AIR FILTER DIFF PRES SENSOR SHORT LOW	Analog Input Circuit Fault
107	15	High Air Filter Differential Pressure Warning	HIGH AIR FILTER DIFF PRES WARNING	Digital Input Circuit Fault and Analog Input Circuit Fault
107	17	Low Air Filter Differential Pressure Warning	LOW AIR FILTER DIFF PRES WARNING	Digital Input Circuit Fault and Analog Input Circuit Fault
110	0	High Engine Coolant Temperature Shutdown	HIGH ENGINE COOLANT TEMP SHUTDOWN	Data Link Circuit Fault and Digital Input Circuit Fault
110	15	High Engine Coolant Temperature Warning	HIGH ENGINE COOLANT TEMP WARNING	Data Link Circuit Fault and Digital Input Circuit Fault
110	17	Low Engine Coolant Temperature Warning	LOW COOLANT TEMP WARNING	Data Link Circuit Fault and Digital Input Circuit Fault
111	0	High Engine Coolant Level Shutdown	HIGH ENG COOL LEVEL SHUTDOWN	Digital Input Circuit Fault and Analog Input Circuit Fault
111	1	Low Engine Coolant Level Shutdown	LOW ENG COOL LEVEL SHUTDOWN	Digital Input Circuit Fault and Analog Input Circuit Fault
111	3	Engine Coolant Level Sensor Short High	ENGINE COOLANT LEVEL SENSOR SHORT HIGH	Analog Input Circuit Fault
111	4	Engine Coolant Level Sensor Short Low	ENGINE COOLANT LEVEL SENSOR SHORT LOW	Analog Input Circuit Fault
111	15	High Engine Coolant Level Warning	HIGH ENG COOL LEVEL WARNING	Digital Input Circuit Fault and Analog Input Circuit Fault
111	17	Low Engine Coolant Level Warning	LOW ENG COOL LEVEL WARNING	Digital Input Circuit Fault and Analog Input Circuit Fault
137	0	High Fire Extinguisher Pressure Shutdown	HIGH FIRE EXTNG PRES SHUTDOWN	Digital Input Circuit Fault and Analog Input Circuit Fault
137	1	Low Fire Extinguisher Pressure Shutdown	LOW FIRE EXTNG PRES SHUTDOWN	Digital Input Circuit Fault and Analog Input Circuit Fault

(continued)

(Table 33, contd)

Trouble Codes				
Suspect Parameter Number (SPN)	Failure Mode Identifier (FMI)	Code Description	Display Text String	Troubleshooting topic
137	3	Fire Extinguisher Pressure Sensor Short High	FIRE EXTING PRES SENSOR SHORT HIGH	Analog Input Circuit Fault
137	4	Fire Extinguisher Pressure Sensor Short Low	FIRE EXTNG PRES SENSOR SHORT LOW	Analog Input Circuit Fault
137	15	High Fire Extinguisher Pressure Warning	HIGH FIRE EXTNG PRES WARNING	Digital Input Circuit Fault and Analog Input Circuit Fault
137	17	Low Fire Extinguisher Pressure Warning	LOW FIRE EXTNG PRES WARNING	Digital Input Circuit Fault and Analog Input Circuit Fault
167	17	Low Battery Charging System Voltage Warning	LOW BATTERY CHARGING SYS VOLT WARN	Charging System
168	0	High Battery Voltage Shutdown	HIGH BATTERY VOLTAGE SHUTDOWN	Charging System
168	15	High Battery Voltage Warning	HIGH BATTERY VOLTAGE WARNING	Charging System
168	17	Low Battery Voltage Warning	LOW BATTERY VOLTAGE WARNING	Charging System
171	0	High Ambient Air Temperature Shutdown	HIGH AMBIENT AIR TEMP SHUTDOWN	Digital Input Circuit Fault and Analog Input Circuit Fault
171	1	Low Ambient Air Temperature Shutdown	LOW AMBIENT AIR TEMP SHUTDOWN	Digital Input Circuit Fault and Analog Input Circuit Fault
171	3	Ambient Air Temperature Sensor Short High	AMBIENT AIR TEMP SENSOR SHORT HIGH	Analog Input Circuit Fault
171	4	Ambient Air Temperature Sensor Short Low	AMBIENT AIR TEMP SENSOR SHORT LOW	Analog Input Circuit Fault
171	15	High Ambient Air Temperature Warning	HIGH AMBIENT AIR TEMP WARNING	Digital Input Circuit Fault and Analog Input Circuit Fault
171	17	Low Ambient Air Temperature Warning	LOW AMBIENT AIR TEMP WARNING	Digital Input Circuit Fault and Analog Input Circuit Fault
173	0	High Exhaust Temperature Shutdown	HIGH EXHAUST TEMP SHUTDOWN	Digital Input Circuit Fault and Analog Input Circuit Fault
173	1	Low Exhaust Temperature Shutdown	LOW EXHAUST TEMP SHUTDOWN	Digital Input Circuit Fault and Analog Input Circuit Fault

(continued)

(Table 33, contd)

Trouble Codes				
Suspect Parameter Number (SPN)	Failure Mode Identifier (FMI)	Code Description	Display Text String	Troubleshooting topic
173	3	Exhaust Temperature Sensor Short High	EXHAUST TEMPERATURE SENSOR SHORT HIGH	Analog Input Circuit Fault
173	4	Exhaust Temperature Sensor Short Low	EXHAUST TEMPERATURE SENSOR SHORT LOW	Analog Input Circuit Fault
173	15	High Exhaust Temperature Warning	HIGH EXHAUST TEMP WARNING	Digital Input Circuit Fault and Analog Input Circuit Fault
173	17	Low Exhaust Temperature Warning	LOW EXHAUST TEMP WARNING	Digital Input Circuit Fault and Analog Input Circuit Fault
175	0	High Engine Oil Temperature Shutdown	HIGH ENGINE OIL TEMP SHUTDOWN	Digital Input Circuit Fault and Analog Input Circuit Fault
175	1	Low Engine Oil Temperature Shutdown	LOW ENGINE OIL TEMP SHUTDOWN	Digital Input Circuit Fault and Analog Input Circuit Fault
175	3	Engine Oil Temperature Sensor Short High	ENGINE OIL TEMP SENSOR SHORT HIGH	Analog Input Circuit Fault
175	4	Engine Oil Temperature Sensor Short Low	ENGINE OIL TEMP SENSOR SHORT LOW	Analog Input Circuit Fault
175	15	High Engine Oil Temperature Warning	HIGH ENGINE OIL TEMP WARNING	Digital Input Circuit Fault and Analog Input Circuit Fault
175	17	Low Engine Oil Temperature Warning	LOW ENGINE OIL TEMP WARNING	Digital Input Circuit Fault and Analog Input Circuit Fault
190	0	Engine Over Speed Shutdown	ENGINE OVER SPEED SHUTDOWN	Engine Over Speed Warning
190	1	Engine Under Speed Shutdown	ENGINE UNDER SPEED SHUTDOWN	Engine Under Speed Warning
190	2	Engine Speed Sensor Erratic or Not Present	ENGINE SPEED SENSOR ERRATIC/LOST	Engine Speed Circuit Fault
190	5	Engine Speed Sensor Open	ENGINE SPEED SENSOR OPEN	Engine Speed Circuit Fault
190	17	Engine Under Speed Warning	ENGINE UNDER SPEED WARNING	Engine Under Speed Warning
625	11	SCADA Data Link Fault	SCADA DATA LINK FAULT	Data Link Circuit Fault
639	11	Primary Data Link Fault	PRIMARY DATA LINK FAULT	Data Link Circuit Fault

(continued)

(Table 33, contd)

<b>Trouble Codes</b>				
<b>Suspect Parameter Number (SPN)</b>	<b>Failure Mode Identifier (FMI)</b>	<b>Code Description</b>	<b>Display Text String</b>	<b>Troubleshooting topic</b>
701	0	Custom Event #1 High Shutdown	CUSTOM EVENT #1 HIGH SHUTDOWN	Digital Input Circuit Fault
701	1	Custom Event #1 Low Shutdown	CUSTOM EVENT #1 LOW SHUTDOWN	Digital Input Circuit Fault
701	15	Custom Event #1 High Warning	CUSTOM EVENT #1 HIGH WARNING	Digital Input Circuit Fault
701	17	Custom Event #1 Low Warning	CUSTOM EVENT #1 LOW WARNING	Digital Input Circuit Fault
701	31	Custom Event #1 Status	CUSTOM EVENT #1 STATUS ACTIVE	Digital Input Circuit Fault
702	0	Custom Event #2 High Shutdown	CUSTOM EVENT #2 HIGH SHUTDOWN	Digital Input Circuit Fault
702	1	Custom Event #2 Low Shutdown	CUSTOM EVENT #2 LOW SHUTDOWN	Digital Input Circuit Fault
702	15	Custom Event #2 High Warning	CUSTOM EVENT #2 HIGH WARNING	Digital Input Circuit Fault
702	17	Custom Event #2 Low Warning	CUSTOM EVENT #2 LOW WARNING	Digital Input Circuit Fault
702	31	Custom Event #2 Status	CUSTOM EVENT #2 STATUS ACTIVE	Digital Input Circuit Fault
703	0	Custom Event #3 High Shutdown	CUSTOM EVENT #3 HIGH SHUTDOWN	Digital Input Circuit Fault
703	1	Custom Event #3 Low Shutdown	CUSTOM EVENT #3 LOW SHUTDOWN	Digital Input Circuit Fault
703	15	Custom Event #3 High Warning	CUSTOM EVENT #3 HIGH WARNING	Digital Input Circuit Fault
703	17	Custom Event #3 Low Warning	CUSTOM EVENT #3 LOW WARNING	Digital Input Circuit Fault
703	31	Custom Event #3 Status	CUSTOM EVENT #3 STATUS ACTIVE	Digital Input Circuit Fault
704	0	Custom Event #4 High Shutdown	CUSTOM EVENT #4 HIGH SHUTDOWN	Digital Input Circuit Fault
704	1	Custom Event #4 Low Shutdown	CUSTOM EVENT #4 LOW SHUTDOWN	Digital Input Circuit Fault

(continued)

(Table 33, contd)

<b>Trouble Codes</b>				
<b>Suspect Parameter Number (SPN)</b>	<b>Failure Mode Identifier (FMI)</b>	<b>Code Description</b>	<b>Display Text String</b>	<b>Troubleshooting topic</b>
704	15	Custom Event #4 High Warning	CUSTOM EVENT #4 HIGH WARNING	Digital Input Circuit Fault
704	17	Custom Event #4 Low Warning	CUSTOM EVENT #4 LOW WARNING	Digital Input Circuit Fault
704	31	Custom Event #4 Status	CUSTOM EVENT #4 STATUS ACTIVE	Digital Input Circuit Fault
705	0	Custom Event #5 High Shutdown	CUSTOM EVENT #5 HIGH SHUTDOWN	Digital Input Circuit Fault
705	1	Custom Event #5 Low Shutdown	CUSTOM EVENT #5 LOW SHUTDOWN	Digital Input Circuit Fault
705	15	Custom Event #5 High Warning	CUSTOM EVENT #5 HIGH WARNING	Digital Input Circuit Fault
705	17	Custom Event #5 Low Warning	CUSTOM EVENT #5 LOW WARNING	Digital Input Circuit Fault
705	31	Custom Event #5 Status	CUSTOM EVENT #5 STATUS ACTIVE	Digital Input Circuit Fault
706	0	Custom Event #6 High Shutdown	CUSTOM EVENT #6 HIGH SHUTDOWN	Digital Input Circuit Fault
706	1	Custom Event #6 Low Shutdown	CUSTOM EVENT #6 LOW SHUTDOWN	Digital Input Circuit Fault
706	15	Custom Event #6 High Warning	CUSTOM EVENT #6 HIGH WARNING	Digital Input Circuit Fault
706	17	Custom Event #6 Low Warning	CUSTOM EVENT #6 LOW WARNING	Digital Input Circuit Fault
706	31	Custom Event #6 Status	CUSTOM EVENT #6 STATUS ACTIVE	Digital Input Circuit Fault
924	3	Digital Output #1 Short High	DIGITAL OUTPUT 1 SHORT HIGH	Digital Output Circuit Fault
925	3	Digital Output #2 Short High	DIGITAL OUTPUT 2 SHORT HIGH	Digital Output Circuit Fault
970	31	Emergency Stop Shutdown	EMERGENCY STOP SHUTDOWN	Digital Input Circuit Fault
1122	0	High Generator Bearing #1 Temperature Shutdown	HIGH GEN BEARING #1 TEMP SHUTDOWN	Digital Input Circuit Fault and Analog Input Circuit Fault
1122	1	Low Generator Rear Bearing Temperature Shutdown	LOW GEN REAR BEARING TEMP SHUTDOWN	Digital Input Circuit Fault and Analog Input Circuit Fault

(continued)

(Table 33, contd)

<b>Trouble Codes</b>				
<b>Suspect Parameter Number (SPN)</b>	<b>Failure Mode Identifier (FMI)</b>	<b>Code Description</b>	<b>Display Text String</b>	<b>Troubleshooting topic</b>
1122	3	Generator Rear Bearing Temperature Sensor Short High	GEN REAR BEARING TEMP SENSOR SHORT HIGH	Analog Input Circuit Fault
1122	4	Generator Rear Bearing Temperature Sensor Short Low	GEN REAR BEARING TEMP SENSOR SHORT LOW	Analog Input Circuit Fault
1122	15	High Rear Generator Bearing Temperature Warning	HIGH GEN REAR BEARING TEMP WARNING	Digital Input Circuit Fault and Analog Input Circuit Fault
1122	17	Low Generator Rear Bearing Temperature Warning	LOW GEN REAR BEARING TEMP WARNING	Digital Input Circuit Fault and Analog Input Circuit Fault
1231	11	Accessory Data Link Fault	ACCESSORY DATA LINK FAULT	Data Link Circuit Fault
1239	31	Fuel Tank Leak (Fuel Rupture Basin)	FUEL TANK LEAK	Digital Input Circuit Fault
1664	31	Engine Failure to Start Shutdown	ENGINE FAILURE TO START SHUTDOWN	Engine Overcrank Warning
2433	0	High Right Exhaust Temperature Shutdown	HIGH RIGHT EXHAUST TEMP SHUTDOWN	Digital Input Circuit Fault and Analog Input Circuit Fault
2433	1	Low Right Exhaust Temperature Shutdown	LOW RIGHT EXHAUST TEMP SHUTDOWN	Digital Input Circuit Fault and Analog Input Circuit Fault
2433	3	Right Exhaust Temperature Sensor Short High	RIGHT EXHAUST TEMP SENSOR SHORT HIGH	Analog Input Circuit Fault
2433	4	Right Exhaust Temperature Sensor Short Low	RIGHT EXHAUST TEMP SENSOR SHORT LOW	Analog Input Circuit Fault
2433	15	High Right Exhaust Temperature Warning	HIGH RIGHT EXHAUST TEMP WARNING	Digital Input Circuit Fault and Analog Input Circuit Fault
2433	17	Low Right Exhaust Temperature Warning	LOW RIGHT EXHAUST TEMP WARNING	Digital Input Circuit Fault and Analog Input Circuit Fault
2434	0	High Left Exhaust Temperature Shutdown	HIGH LEFT EXHAUST TEMP SHUTDOWN	Digital Input Circuit Fault and Analog Input Circuit Fault
2434	1	Low Left Exhaust Temperature Shutdown	LOW LEFT EXHAUST TEMP SHUTDOWN	Digital Input Circuit Fault and Analog Input Circuit Fault
2434	3	Left Exhaust Temperature Sensor Short High	LEFT EXHAUST TEMP SENSOR SHORT HIGH	Analog Input Circuit Fault

(continued)

(Table 33, contd)

Trouble Codes				
Suspect Parameter Number (SPN)	Failure Mode Identifier (FMI)	Code Description	Display Text String	Troubleshooting topic
2434	4	Left Exhaust Temperature Sensor Short Low	LEFT EXHAUST TEMP SENSOR SHORT LOW	Analog Input Circuit Fault
2434	15	High Left Exhaust Temperature Warning	HIGH LEFT EXHAUST TEMP WARNING	Analog Input Circuit Fault
2434	17	Low Left Exhaust Temperature Warning	LOW LEFT EXHAUST TEMP WARNING	Digital Input Circuit Fault and Analog Input Circuit Fault
2436	0	Generator Over Frequency Shutdown	GEN OVER FREQUENCY SHUTDOWN	Generator Over Frequency Warning
2436	1	Generator Under Frequency Shutdown	GEN UNDER FREQUENCY SHUTDOWN	Generator Under Frequency Warning
2436	2	Engine Speed-Generator Output Frequency Mismatch Warning	ENG SPEED-GEN FREQ MISMATCH WARN	Engine Speed Warning
2436	12	Generator Output Sensing System Failure	GEN AC METERING SYS FAILURE	Generator Output Sensing Circuit Fault
2436	15	Generator Over Frequency Warning	GEN OVER FREQUENCY WARNING	Generator Over Frequency Warning
2436	17	Generator Under Frequency Warning	GEN UNDER FREQUENCY WARNING	Generator Under Frequency Warning
2440	0	Generator Over Voltage Shutdown	GEN OVER VOLTAGE SHUTDOWN	Generator Over Voltage Warning
2440	1	Generator Under Voltage Shutdown	GEN UNDER VOLTAGE SHUTDOWN	Generator Under Voltage Warning
2440	15	Generator Over Voltage Warning	GEN OVER VOLTAGE WARNING	Generator Over Voltage Warning
2440	17	Generator Under Voltage Warning	GEN UNDER VOLTAGE WARNING	Generator Under Voltage Warning
2448	0	Generator Over Current Shutdown	GEN OVER CURRENT SHUTDOWN	Generator Over Current Warning
2448	15	Generator Over Current Warning	GEN OVER CURRENT WARNING	Generator Over Current Warning
2452	1	Generator Reverse Power Shutdown	GEN REVERSE POWER SHUTDOWN	Generator Reverse Power Warning

(continued)

(Table 33, contd)

<b>Trouble Codes</b>				
<b>Suspect Parameter Number (SPN)</b>	<b>Failure Mode Identifier (FMI)</b>	<b>Code Description</b>	<b>Display Text String</b>	<b>Troubleshooting topic</b>
2452	17	Generator Reverse Power Warning	GEN REVERSE POWER WARNING	Generator Reverse Power Warning
2648	31	Service Maintenance Interval Warning	SERV MAINT INTERVAL WARNING	Service Information Interval Warning
4000	31	Air Damper Closed	AIR DAMPER CLOSED	Digital Input Circuit Fault
4001	31	ATS in Normal Position	ATS IN NORMAL POSITION	Digital Input Circuit Fault
4002	31	ATS in Emergency Position	ATS IN EMERGENCY POSITION	Digital Input Circuit Fault
4003	31	Battery Charger Failure	BATTERY CHARGER FAILURE	Digital Input Circuit Fault
4004	31	Generator Circuit Breaker Closed	GENERATOR BREAKER CLOSED	Digital Input Circuit Fault
4005	31	Utility Circuit Breaker Closed	UTILITY BREAKER CLOSED	Digital Input Circuit Fault
4006	31	Engine in Cooldown	ENGINE IN COOLDOWN	Engine Cooldown Warning
4007	31	Generator Control Not in Automatic Warning	GEN CONTROL NOT IN AUTO WARNING	Generator Control Not In Automatic Warning
4008	31	Unexpected Engine Shutdown	UNEXPECTED ENGINE SHUTDOWN	Unexpected Engine Shutdown

# Diagnostic System Procedures

i02461491

## Engine Cooldown Warning

i02461490

**SMCS Code:** 4490

### System Operation Description:

The following conditions cause the engine to enter a stop mode

- Loss of a remote initiate signal
- Activation of the stop signal input
- A data link message calling for a engine shutdown

If the engine is running, the engine will continue to run in cooldown. When the cooldown interval is complete, the engine will stop. An immediate shutdown due to a critical fault will cause the engine to shutdown and the Cooldown Timer to be bypassed.

**Reference:** For more information on setting the cooldown duration setpoint, see Testing and Adjusting, "Electronic Control Module (Generator Set) - Configure",

### Conditions Which Generate This Code:

The code for the engine cooldown is generated when the EMCP 3 determines that an engine cooldown is in progress. The engine will continue to run until the cooldown duration time has expired.

### Talk to the Operator

**Note:** No repair to the engine is necessary.

**A.** Determine the conditions that caused the diagnostic code.

### Expected Result:

A shutdown was initiated by the operator or by the software that caused the engine to enter into the cooldown mode.

### Results:

- OK – STOP.

## Engine Overcrank Warning

**SMCS Code:** 4490

### System Operation Description:

The crank cycle and the number of crank cycles are programmable. The crank cycle is the amount of time for engagement of the starting motor. This also includes the amount of time for cooling of the starting motor between crank cycles. If the engine does not start within the number of crank cycles that are programmed, "ENGINE FAILURE TO START SHUTDOWN" will be displayed on the EMCP 3 in order to inform the operator of an overcrank condition.

**Note:** Refer to the engine Troubleshooting manual for more information on engine starting and engine cranking for your particular genset.

### Conditions Which Generate This Code:

The code for the engine overcrank is generated when the EMCP 3 determines that an engine overcrank condition has occurred.

### Test Step 1. PERFORM THE INITIAL CHECK.

**A.** Check for active diagnostic codes on the engine ECM and the EMCP 3. If any codes are present, correct the diagnostic codes first.

### Expected Result:

No other diagnostic codes or indicators are active.

### Results:

- OK – No other diagnostic codes or indicators are active. Proceed to Test Step 2
- NOT OK – Another diagnostic code is active or an indicator is active.

**Repair:** Exit this procedure. Troubleshoot the active code or indicator. Resume normal operation and verify that the problem has been corrected.

STOP.

### Test Step 2. CHECK THE SETPOINTS.

**A.** View the setpoints (Crank Duration, Crank Cycle Rest Interval, and Maximum Number of Crank Cycles). Make a note of the setpoints. See Testing and Adjusting, "Electronic Control Module (Generator Set) - Configure". Compare the setpoints against the default setpoints of the particular generator set.

**Expected Result:**

The setpoints are correct.

**Results:**

- OK – The setpoints are correct for your particular genset. Proceed to Test Step 3 for MUI engines. Proceed to Test step 4 for EUI engines.
- NOT OK – The setpoints are NOT correct.

**Repair:** Reprogram the setpoints. Reset the genset. Resume normal operation and verify that the problem has been corrected.

STOP.

**Test Step 3. Inspect the 2301A Governor Power Source and Wiring. (MUI Engines Only)**

Refer to the Genset Electrical System Schematic in the Service Manual for an accurate representation of the genset that is being serviced.

- A.** Verify the Emergency Stop Push Button is not pressed
- B.** Verify pin 58 on the EMCP 3 is connected through a normally open contact on the emergency stop switch to battery positive.
- C.** Verify the Fuel Control Relay Output on pin 38 of the EMCP 3 is connected to terminal 2 on the 2301A Governor and verify the in line fuse is not open.
- D.** Verify terminal 1 on the 2301A is connected to battery negative.

**Expected Result:**

The 2301A Governor power Source and wiring are correct.

**Results:**

- OK – The wiring is correct. The EMCP 3 may have failed.

**Repair:** It is unlikely that the EMCP 3 has failed. Exit this procedure and perform this procedure again. If the failure is not found, replace the EMCP 3.

STOP.

- NOT OK – The wiring is not correct.

**Repair:** Repair the wiring or replace the wiring. Reset the genset. Resume normal operation and verify that the problem has been corrected.

STOP.

**Test Step 4. Check communications between EMCP 3 and Engine ECM. (EUI Engines Only)**

- A.** Use the Caterpillar Electronic Technician in order to verify that the fuel enable input on the Engine ECM is configured for "CAN Input".
- B.** Refer to the Genset Electrical System Schematic in the Service Manual and check the Data Link wiring between the EMCP and the Engine ECM. See Troubleshooting, "Data Link Circuit Fault"

**Results:**

- OK – The Data Link wiring is correct. The EMCP 3 may have failed.

**Repair:** It is unlikely that the EMCP 3 has failed. Exit this procedure and perform this procedure again. If the failure is not found, replace the EMCP 3.

STOP.

- NOT OK – The wiring is not correct.

**Repair:** Repair the wiring or replace the wiring. Reset the genset. Resume normal operation and verify that the problem has been corrected.

STOP.

i02463431

**Engine Speed Warning**

**SMCS Code:** 4490

**System Operation Description:**

The EMCP 3 determines the engine speed, in rpm, from the magnetic pickup. The input from the magnetic pickup will be a frequency that is proportional to the engine speed and to the number of flywheel teeth. The EMCP 3 will convert the frequency of the engine speed sensor input into rpm based on the flywheel teeth setpoint value.

The relationship between engine speed and generator frequency can be computed based on the number of generator poles. If the engine speed does not correspond to the generator frequency, ENG SPEED-GEN FREQ MISMATCH WARN will be displayed on the EMCP 3. This message informs the operator of the mismatch condition.

**Note:** Refer to the engine Troubleshooting manual for more information regarding engine speed for your particular genset.

#### Conditions Which Generate This Code:

This code is generated when engine speed and frequency values mismatch by more than 10% for more than 10 seconds, If the setpoint for number of generator poles is set to a value of 0 poles, then this condition is not tested

#### Test Step 1. PERFORM THE INITIAL CHECK.

- A.** Check for active diagnostic codes on the engine ECM and the EMCP 3. If any codes are present, correct the diagnostic codes first.

#### Expected Result:

No other diagnostic codes or indicators are active.

#### Results:

- OK – No other diagnostic codes or indicators are active. Proceed to Test Step 2
- NOT OK – Another diagnostic code is active or an indicator is active.

**Repair:** Exit this procedure. Troubleshoot the active code or indicator. Resume normal operation and verify that the problem has been corrected.

STOP.

#### Test Step 2. CHECK THE SETPOINTS.

- A.** View the setpoints (number of generator poles) and (flywheel teeth). Make a note of the setpoints. See Testing and Adjusting, “Electronic Control Module (Generator Set) - Configure”. Compare the setpoints against the default setpoints of the particular generator set.

#### Expected Result:

The setpoints are correct.

#### Results:

- OK – The setpoints are correct for your particular genset.

**Repair:** Reset the genset. Resume normal operation and verify that the problem has been corrected.

STOP.

- NOT OK – The setpoints are NOT correct.

**Repair:** Reprogram the setpoints. Reset the genset. Resume normal operation and verify that the problem has been corrected.

STOP.

i02461492

## Engine Overspeed Warning

**SMCS Code:** 4490

#### System Operation Description:

If the engine speed rises above the Engine Overspeed Threshold setpoint value, the Engine Overspeed event is made active.

If a overspeed condition is detected, “ENGINE OVERSPEED SHUTDOWN” will be displayed on the EMCP 3 in order to inform the operator of an overspeed condition. The Engine Overspeed Shutdown will always be a hard shutdown and may not be disabled.

#### Conditions Which Generate This Code:

The code for engine overspeed is generated when the EMCP 3 determines that an engine overspeed condition has occurred.

#### Test Step 1. TALK TO THE OPERATOR

- A.** Determine the conditions that caused the overspeed condition.

#### Expected Result:

A overspeed was caused by a occurrence known to the operator and the operator would like to put the genset back into service.

#### Results:

- OK – The operator can determine the cause for the overspeed condition, the condition has been repaired and the operator wants to put the genset back into service.

**Repair:** Reset the genset. Resume normal operation and verify that the problem has been corrected.

STOP.

- NOT OK – The overspeed condition was not caused by a occurrence known to the operator. Proceed to Test Step 2

### Test Step 2. CHECK THE SETPOINTS.

- A. View the Engine Speed Monitor and Generator Desired Engine Speed Request setpoints. Make a note of the setpoints. See Testing and Adjusting, "Electronic Control Module (Generator Set) - Configure". Compare the setpoints against the default setpoints of the particular generator set.

#### Expected Result:

The setpoints are correct.

#### Results:

- OK – The setpoints are correct for your particular genset. Proceed to test step 3 for EUI engines. Proceed to test step 4 for MUI engines
- NOT OK – The setpoints are NOT correct.

**Repair:** Reprogram the setpoints. Reset the genset. Resume normal operation and verify that the problem has been corrected.

STOP.

### Test Step 3. VERIFY ENGINE SPEED CAN BE VIEWED AND ADJUSTED FROM THE EMCP 3 (EUI ENGINES ONLY)

Verify the engine speed can be viewed and adjusted from the EMCP 3 Display Screen.

#### Expected Result:

The engine speed can be viewed and adjusted from the EMCP 3 Display Screen.

#### Results:

- OK – The engine speed can be viewed and adjusted from the EMCP 3 Display Screen.

**Repair:** Adjust the engine speed to meet site requirements. Resume normal operation and verify that the problem has been corrected.

STOP.

- NOT OK – The engine speed cannot be adjusted. Proceed to test step 7
- NOT OK – The engine speed reads zero on the EMCP Display Screen.

**Repair:** The Engine Speed Sensor may have failed or needs to be adjusted. See Testing And Adjusting, "Speed Sensor (Engine) - Adjust". If the problem remains, replace the Engine Speed Sensor.

STOP.

### Test Step 4. CHECK THE SYSTEM BY USING THE SPEED POTENTIOMETER. (MUI ENGINES ONLY)

- A. With the engine running, adjust the speed of the engine by turning the speed potentiometer.

#### Expected Result:

The engine can be adjusted to the desired speed.

#### Results:

- OK – The engine speed can be adjusted.

**Repair:** Adjust the engine speed to meet site requirements. Resume normal operation and verify that the problem has been corrected.

STOP.

- NOT OK – The engine speed cannot be adjusted with the speed potentiometer. Proceed to test step 5

### Test Step 5. CHECK THE RESISTANCE OF THE ENGINE SPEED POTENTIOMETER. (MUI ENGINES ONLY)

- A. Shut down the engine.

- B. Disconnect the speed potentiometer from the terminals "11" and "12" on the 2301A Governor.

- C. At the speed potentiometer, measure the resistance of the speed potentiometer.

#### Expected Result:

The resistance should be adjustable between 0 and 100 ohms.

#### Results:

- OK – The resistance of the sensor is correct. Proceed to Test Step 6.
- NOT OK – The resistance of the speed potentiometer is not correct.

**Repair:** Replace the speed potentiometer. Resume normal operation and verify that the problem has been corrected.

STOP.

### Test Step 6. CHECK THE SPEED POTENTIOMETER HARNESS FOR AN OPEN CIRCUIT. (MUI ENGINES ONLY)

- A. Disconnect the speed potentiometer harness from the 2301A governor.
- B. Check for an open circuit. Check the resistance from the wire connected to terminal "11" of the 2301A governor to the same wire number at the speed potentiometer. The resistance should be 5 ohms or less.
- C. Check for an open circuit. Check the resistance from the wire connected to terminal "12" of the 2301A governor to the same wire number at the speed potentiometer. The resistance should be 5 ohms or less.

#### Expected Result:

When the resistance is measured between the wire connected to terminal "11" of the 2301A governor to the same wire number at the speed potentiometer connector, the resistance should be 5 ohms or less.

When the resistance is measured between the wire connected to terminal "12" of the 2301A governor to the same wire number at the speed potentiometer connector, the resistance should be 5 ohms or less.

#### Results:

- OK – The harness functions properly.

**Repair:** The EMCP 3 may have failed. It is unlikely that the EMCP 3 has failed. Exit this procedure and perform this entire procedure again. If the problem remains, replace the EMCP 3. See Testing And Adjusting, " Electronic Control Module (Generator Set) - Replace".

STOP.

- NOT OK – The harness wiring with the incorrect resistance measurement has failed. Replace the failed harness from the 2301A governor to the speed potentiometer or repair the failed harness from the 2301A governor to the speed potentiometer. Resume normal operation and verify that the problem has been corrected. STOP.

### Test Step 7. CHECK J1939 DATA LINK BETWEEN THE EMCP 3 AND THE ENGINE ECM (EUI ENGINES ONLY)

Refer to the Genset Electrical System Schematic in the Service Manual and check the Data Link wiring between the EMCP 3 and the Engine ECM. For more information on troubleshooting the Data Link, see Troubleshooting, "Data Link Circuit Fault".

#### Results:

- OK – The J1939 Data Link wiring is correct.

**Repair:** The EMCP 3 may have failed. It is unlikely that the EMCP 3 has failed. Exit this procedure and perform this entire procedure again. If the problem remains, replace the EMCP 3. See Testing And Adjusting, " Electronic Control Module (Generator Set) - Replace".

STOP.

- NOT OK – The wiring is not correct

**Repair:** Repair the Data Link wiring or Replace the Data Link wiring. Resume normal operation and verify the problem has been corrected.

STOP.

i02461493

## Engine Underspeed Warning

**SMCS Code:** 4490

#### System Operation Description:

If the engine speed drops below the Engine Underspeed Threshold setpoint value, the underspeed timer will begin timing. When the timer expires, the Engine Underspeed event is made active (if the engine speed has been below the threshold level continuously while timing). If the engine speed rises above the Engine Underspeed Threshold, the Engine Underspeed event will be made inactive and the timer will be reset.

If a underspeed condition is detected, "ENGINE UNDERSPEED SHUTDOWN" or "ENGINE UNDERSPEED WARNING" will be displayed on the EMCP 3 in order to inform the operator of an underspeed condition.

**Note:** The severity of the underspeed condition will determine if a warning or shutdown event occurs.

#### Conditions Which Generate This Code:

The code for engine underspeed is generated when the EMCP 3 determines that an engine underspeed condition has occurred.

### Test Step 1. TALK TO THE OPERATOR

A. Determine the conditions that caused the underspeed condition.

#### Expected Result:

A underspeed was caused by a occurrence known to the operator and the operator would like to put the genset back into service.

#### Results:

- OK – The operator can determine the cause for the underspeed condition, the condition has been repaired and the operator wants to put the genset back into service.

**Repair:** Reset the genset. Resume normal operation and verify that the problem has been corrected.

STOP.

- NOT OK – The underspeed condition was not caused by an occurrence known to the operator. Proceed to Test Step 2

### Test Step 2. CHECK THE SETPOINTS.

A. View the Engine Speed Monitor and Generator Desired Engine Speed Request setpoints. Make a note of the setpoints. See Testing and Adjusting, "Electronic Control Module (Generator Set) - Configure". Compare the setpoints against the default setpoints of the particular generator set.

#### Expected Result:

The setpoints are correct.

#### Results:

- OK – The setpoints are correct for your particular genset. Proceed to test step 3 for EUI engines. Proceed to test step 4 for MUI engines
- NOT OK – The setpoints are NOT correct.

**Repair:** Reprogram the setpoints. Reset the genset. Resume normal operation and verify that the problem has been corrected.

STOP.

### Test Step 3. VERIFY ENGINE SPEED CAN BE VIEWED AND ADJUSTED FROM THE EMCP 3 (EUI ENGINES ONLY)

Verify the engine speed can be viewed and adjusted from the EMCP 3 Display Screen.

#### Expected Result:

The engine speed can be viewed and adjusted from the EMCP 3 Display Screen.

#### Results:

- OK – The engine speed can be viewed and adjusted from the EMCP 3 Display Screen.

**Repair:** Adjust the engine speed to meet site requirements. Resume normal operation and verify that the problem has been corrected.

STOP.

- NOT OK – The engine speed cannot be adjusted. Proceed to test step 7
- NOT OK – The engine speed reads zero on the EMCP Display Screen.

**Repair:** The Engine Speed Sensor may have failed or needs to be adjusted. See Testing And Adjusting, "Speed Sensor (Engine) - Adjust". If the problem remains, replace the Engine Speed Sensor.

STOP.

### Test Step 4. CHECK THE SYSTEM BY USING THE SPEED POTENTIOMETER. (MUI ENGINES ONLY)

A. With the engine running, adjust the speed of the engine by turning the speed potentiometer.

#### Expected Result:

The engine can be adjusted to the desired speed.

#### Results:

- OK – The engine speed can be adjusted.

**Repair:** Adjust the engine speed to meet site requirements. Resume normal operation and verify that the problem has been corrected.

STOP.

- NOT OK – The engine speed cannot be adjusted with the speed potentiometer. Proceed to test step 5

### Test Step 5. CHECK THE RESISTANCE OF THE ENGINE SPEED POTENTIOMETER. (MUI ENGINES ONLY)

A. Shut down the engine.

**B.** Disconnect the speed potentiometer from the terminals "11" and "12" on the 2301A Governor.

**C.** At the speed potentiometer, measure the resistance of the speed potentiometer.

**Expected Result:**

The resistance should be adjustable between 0 and 100 ohms.

**Results:**

- OK – The resistance of the sensor is correct. Proceed to Test Step 6.
- NOT OK – The resistance of the speed potentiometer is not correct.

**Repair:** Replace the speed potentiometer. Resume normal operation and verify that the problem has been corrected.

STOP.

**Test Step 6. CHECK THE SPEED POTENTIOMETER HARNESS FOR A OPEN CIRCUIT. (MUI ENGINES ONLY)**

**A.** Disconnect the speed potentiometer harness from the 2301A governor.

**B.** Check for an open circuit. Check the resistance from the wire connected to terminal "11" of the 2301A governor to the same wire number at the speed potentiometer. The resistance should be 5 ohms or less.

**C.** Check for an open circuit. Check the resistance from the wire connected to terminal "12" of the 2301A governor to the same wire number at the speed potentiometer. The resistance should be 5 ohms or less

**Expected Result:**

When the resistance is measured between the wire connected to terminal "11" of the 2301A governor to the same wire number at the speed potentiometer connector, the resistance should be 5 ohms or less.

When the resistance is measured between the wire connected to terminal "12" of the 2301A governor to the same wire number at the speed potentiometer connector, the resistance should be 5 ohms or less.

**Results:**

- OK – The harness functions properly.

**Repair:** The EMCP 3 may have failed. It is unlikely that the EMCP 3 has failed. Exit this procedure and perform this entire procedure again. If the problem remains, replace the EMCP 3. See Testing And Adjusting, " Electronic Control Module (Generator Set) - Replace".

STOP.

- NOT OK – The harness wiring with the incorrect resistance measurement has failed.

**Repair:** Replace the failed harness from the 2301A governor to the speed potentiometer or repair the failed harness from the 2301A governor to the speed potentiometer. Resume normal operation and verify that the problem has been corrected.

STOP.

**Test Step 7. CHECK THE J1939 DATA LINK BETWEEN THE EMCP 3 AND THE ENGINE ECM (EUI ENGINES ONLY)**

Refer to the Genset Electrical System Schematic in the Service Manual and check the Data Link wiring between the EMCP 3 and the Engine ECM. For more information on troubleshooting the Data Link, see Troubleshooting, "Data Link Circuit Fault".

**Results:**

- OK – The J1939 Data Link wiring is correct.

**Repair:** The EMCP 3 may have failed. It is unlikely that the EMCP 3 has failed. Exit this procedure and perform this entire procedure again. If the problem remains, replace the EMCP 3. See Testing And Adjusting, " Electronic Control Module (Generator Set) - Replace".

STOP.

- NOT OK – The wiring is not correct

**Repair:** Repair the Data Link wiring or Replace the Data Link wiring. Resume normal operation and verify the problem has been corrected.

STOP.

i02464700

i02461494

## Generator Control Not in Automatic Warning

**SMCS Code:** 4490

### System Operation Description:

Pressing the Auto Key or a Modbus RS-485 SCADA Data Link message causes the engine to enter AUTO mode. When the engine is in AUTO mode and no shutdowns are active, then continuous activation of the Remote Initiate input causes the engine to start and to run (after a programmed Start Aid Activation delay and Crank Alert interval). When the Remote Initiate signal is removed, then the engine will cool down and then stop. When the genset control is not in AUTO mode, "GEN CONTROL NOT IN AUTO WARNING" will be displayed on the EMCP 3 in order to inform the operator of the not in auto condition.

**Note:** The event can be disabled via the Generator Control Not in Automatic Warning Event Response Configuration setpoint).

### Conditions Which Generate This Code:

The code is generated when the genset control is not in AUTO mode.

### Talk to the Operator

**Note:** No repair to the engine is necessary.

**A.** Determine the conditions that caused the diagnostic code.

### Expected Result:

The generator was place into a mode other than AUTO by the operator or by a Modbus RS-485 SCADA data link message .

### Results:

- OK – STOP.

## Generator Output Sensing Circuit Fault

**SMCS Code:** 4490

### System Operation Description:

If the engine is running and the EMCP 3 is receiving AC voltage and current information, but not processing any AC measurements, then the "GENERATOR OUTPUT SENSING CIRCUIT FAULT" is made active. The EMCP 3 has failed.

Perform the following procedure: Electronic Control Module (Generator Set) - Replace

### Results:

- OK – STOP.

i02461495

## Generator Overcurrent Warning

**SMCS Code:** 4490

### System Operation Description:

The EMCP 3 detects an overcurrent condition that persists for a duration that is a function of the over current level or a condition that exceeds a threshold for a programmed duration. If the RMS current of any phase goes above the Generator Definite Time Over Current (Amp) Percentage Threshold, then a timer is started and the Generator Over Current event is made active.

The tripping time for generator overcurrent detection is determined from the phase with the highest current, and is the smaller of two values: the Curve Time and the Generator Definite Time Over Current (Amp) Shutdown Event Notification Delay Time (setpoint value).

If an overcurrent condition is detected, then "GEN OVER CURRENT SHUTDOWN" or "GEN OVERCURRENT WARNING" will be displayed on the EMCP 3 in order to inform the operator of an overcurrent condition.

**Note:** The severity of the overcurrent condition will determine if a warning or shutdown event occurs.

### Conditions Which Generate This Code:

The code for generator overcurrent is generated when the EMCP 3 determines that a generator overcurrent condition has occurred.

### Test Step 1. TALK TO THE OPERATOR

- A.** Determine the conditions that caused the overcurrent condition.

#### Expected Result:

An overcurrent was caused by a occurrence known to the operator and the operator would like to put the genset back into service.

#### Results:

- OK – The operator can determine the cause for the overcurrent condition, the condition has been repaired and the operator wants to put the genset back into service.

**Repair:** Reset the genset. Resume normal operation and verify that the problem has been corrected.

STOP.

- NOT OK – The overcurrent condition was not caused by an occurrence known to the operator. Proceed to Test Step 2

### Test Step 2. CHECK THE SETPOINTS.

- A.** View the setpoints (Generator Current Transformer Primary Winding Rating), (Generator Current Transformer Secondary Winding Rating), and all of the overcurrent setpoints. Make a note of the setpoints. See Testing and Adjusting, “Electronic Control Module (Generator Set) - Configure”. Compare the setpoints against the default setpoints of the particular generator set.

#### Expected Result:

The setpoints are correct.

#### Results:

- OK – The setpoints are correct for your particular genset.

**Repair:** Reset the genset. Resume normal operation and verify that the problem has been corrected.

STOP.

- NOT OK – The setpoints are NOT correct.

**Repair:** Reprogram the setpoints. Reset the genset. Resume normal operation and verify that the problem has been corrected.

STOP.

102464697

## Generator Overfrequency Warning

**SMCS Code:** 4490

#### System Operation Description:

If the frequency rises above the Generator Overfrequency Percentage Threshold setpoint value, then the overfrequency timer will begin timing. When the timer expires, the Generator Overfrequency event is made active (if the frequency has been above the threshold level continuously while timing). If the frequency rises above the Generator Overfrequency Percentage Threshold, then the Generator Overfrequency event will be made inactive and the timer will be reset.

If an overfrequency condition is detected, then “GEN OVERFREQUENCY SHUTDOWN” or “GEN OVERFREQUENCY WARNING” will be displayed on the EMCP 3 in order to inform the operator of an overfrequency condition.

**Note:** The severity of the overfrequency condition will determine if a warning or shutdown event occurs.

#### Conditions Which Generate This Code:

The code for generator overfrequency is generated when the EMCP 3 determines that a generator overfrequency condition has occurred.

### Test Step 1. TALK TO THE OPERATOR

- A.** Determine the conditions that caused the overfrequency condition.

#### Expected Result:

An overfrequency condition was caused by an occurrence that is known to the operator and the operator would like to put the genset back into service.

#### Results:

- OK – The operator can determine the cause for the overfrequency condition, the condition has been repaired and the operator wants to put the genset back into service.

**Repair:** Reset the genset. Resume normal operation and verify that the problem has been corrected.

STOP.

- NOT OK – The overfrequency condition was not caused by an occurrence known to the operator. Proceed to Test Step 2

### Test Step 2. CHECK THE SETPOINTS.

**A.** View the Generator Overfrequency and Generator Desired Engine Speed Request setpoints. Make a note of the setpoints. See Testing and Adjusting, “Electronic Control Module (Generator Set) - Configure”. Compare the setpoints against the default setpoints of the particular generator set.

#### Expected Result:

The setpoints are correct.

#### Results:

- OK – The setpoints are correct for your particular genset. Proceed to test step 3 for EUI engines. Proceed to test step 4 for MUI engines
- NOT OK – The setpoints are NOT correct.

**Repair:** Reprogram the setpoints. Reset the genset. Resume normal operation and verify that the problem has been corrected.

STOP.

### Test Step 3. VERIFY FREQUENCY CAN BE VIEWED AND ADJUSTED FROM THE EMCP 3 (EUI ENGINES ONLY)

Verify the generator output frequency can be viewed and adjusted from the EMCP 3 Display Screen.

#### Expected Result:

The generator output frequency can be viewed and adjusted from the EMCP 3 Display Screen.

#### Results:

- OK – The generator output frequency can be viewed and adjusted from the EMCP 3 Display Screen.

**Repair:** Adjust the generator output frequency to meet site requirements. Resume normal operation and verify that the problem has been corrected.

STOP.

- NOT OK – The generator output frequency cannot be adjusted. Proceed to test step 7
- NOT OK – The generator frequency reads zero on the EMCP Display Screen. Proceed to test step 8

### Test Step 4. CHECK THE SYSTEM BY USING THE SPEED POTENTIOMETER. (MUI ENGINES ONLY)

**A.** With the engine running, adjust the generator output frequency by turning the speed potentiometer.

#### Expected Result:

The generator output frequency can be adjusted to the desired frequency.

#### Results:

- OK – The generator output frequency can be adjusted.

**Repair:** Adjust the generator output frequency to meet site requirements. Resume normal operation and verify that the problem has been corrected.

STOP.

- NOT OK – The generator output frequency cannot be adjusted with the speed potentiometer. Proceed to test step 5

### Test Step 5. CHECK THE RESISTANCE OF THE ENGINE SPEED POTENTIOMETER. (MUI ENGINES ONLY)

**A.** Shut down the engine.

**B.** Disconnect the speed potentiometer from the terminals “11” and “12” on the 2301A Governor.

**C.** At the speed potentiometer, measure the resistance of the speed potentiometer.

#### Expected Result:

The resistance should be adjustable between 0 and 100 ohms.

#### Results:

- OK – The resistance of the sensor is correct. Proceed to Test Step 6.
- NOT OK – The resistance of the speed potentiometer is not correct.

**Repair:** Replace the speed potentiometer. Resume normal operation and verify that the problem has been corrected.

STOP.

### **Test Step 6. CHECK THE SPEED POTENTIOMETER HARNESS FOR AN OPEN CIRCUIT. (MUI ENGINES ONLY)**

- A. Disconnect the speed potentiometer harness from the 2301A governor.
- B. Check for an open circuit. Check the resistance from the wire connected to terminal "11" of the 2301A governor to the same wire number at the speed potentiometer. The resistance should be 5 ohms or less.
- C. Check for an open circuit. Check the resistance from the wire connected to terminal "12" of the 2301A governor to the same wire number at the speed potentiometer. The resistance should be 5 ohms or less.

#### **Expected Result:**

When the resistance is measured between the wire connected to terminal "11" of the 2301A governor to the same wire number at the speed potentiometer connector, the resistance should be 5 ohms or less.

When the resistance is measured between the wire connected to terminal "12" of the 2301A governor to the same wire number at the speed potentiometer connector, the resistance should be 5 ohms or less.

#### **Results:**

- OK – The harness functions properly. Proceed to test step 8
- NOT OK – The harness wiring with the incorrect resistance measurement has failed. Replace the failed harness from the 2301A governor to the speed potentiometer or repair the failed harness from the 2301A governor to the speed potentiometer. Resume normal operation and verify that the problem has been corrected. STOP.

### **Test Step 7. CHECK J1939 DATA LINK BETWEEN THE EMCP 3 AND THE ENGINE ECM (EUI ENGINES ONLY)**

Refer to the Genset Electrical System Schematic in the Service Manual and check the Data Link wiring between the EMCP 3 and the Engine ECM. For more information on troubleshooting the Data Link, see Troubleshooting , "Data Link Circuit Fault ".

#### **Results:**

- OK – The J1939 Data Link wiring is correct. Proceed to test step 8
- NOT OK – The wiring is not correct

**Repair:** Repair the Data Link wiring or Replace the Data Link wiring. Resume normal operation and verify that the problem has been corrected.

STOP.

### **Test Step 8. CHECK THE VOLTAGE INPUT FUSES.**

- A. Check the three fuses on the AC voltage inputs of the EMCP 3.

#### **Expected Result:**

The fuses should not be open.

#### **Results:**

- OK – The fuses are not open. Proceed to test step 9
- NOT OK – One or more of the fuses are open.

**Repair:** Check for a shorted component or damaged wiring. Troubleshoot and repair the problem. See the Generator Set Wiring Diagram for your particular genset. After the problem has been repaired, replace the fuses.

STOP.

### **Test Step 9. CHECK THE GENERATOR VOLTAGE OUTPUT.**

- A. Open the circuit breaker or remove the load.
- B. Start the engine and run the genset.
- C. Measure the voltage between all three AC input fuses.

#### **Expected Result:**

The line to line voltage should measure the rated voltage of the genset.

#### **Results:**

- OK – The voltages are correct and the problem remains. Proceed to Test Step 10.
- NOT OK – One or more of the voltages are NOT correct.

**Repair:** The wiring or the connections the are damaged. Check for damaged wiring between the fuses and the generator output bus. See the Generator Set Wiring Diagram for your particular genset. Repair the wiring or replace the wiring. Resume normal operation and verify the problem has been corrected.

STOP.

### Test Step 10. CHECK THE VOLTAGE INPUT CONNECTIONS

- A. Shut down the engine.
- B. Remove the EMCP 3 harness connector from the EMCP 3.
- C. Check the EMCP 3 harness connector. See Testing And Adjusting, "Electrical Connector - Inspect".
- D. Check for one or more damaged wires between the EMCP 3 voltage inputs and the voltage input fuses. See the Generator Set Wiring Diagram for your particular genset.

#### Expected Result:

The wiring and the connectors should have been good.

#### Results:

- OK – NO problem was found with the connectors or with the wiring.

**Repair:** The EMCP 3 may have failed. It is unlikely that the EMCP 3 has failed. Exit this procedure and perform this entire procedure again. If the problem remains, replace the EMCP 3. See Testing And Adjusting, " Electronic Control Module (Generator Set) - Replace".

STOP.

- NOT OK – The problem was with the connectors or with the wiring.

**Repair:** Repair the connectors or replace the wiring harness. Resume normal operation and verify that the problem has been corrected.

STOP.

## Generator Overvoltage Warning

**SMCS Code:** 4490

#### System Operation Description:

If the voltage rises above the Generator Overvoltage Percentage Threshold setpoint value, then the overvoltage timer will begin timing. When the timer expires, the Generator Overvoltage event is made active (if the voltage has been above the threshold level continuously while timing). If the voltage drops below the Generator Overvoltage Percentage Threshold, then the Generator Overvoltage event will be made inactive and the timer will be reset.

If an overvoltage condition is detected, then "GEN OVERVOLTAGE SHUTDOWN" or "GEN OVERVOLTAGE WARNING" will be displayed on the EMCP 3 in order to inform the operator of an overvoltage condition.

**Note:** The severity of the overvoltage condition will determine if a warning or shutdown event occurs.

#### Conditions Which Generate This Code:

The code for generator overvoltage is generated when the EMCP 3 determines that a generator overvoltage condition has occurred.

### Test Step 1. TALK TO THE OPERATOR

- A. Determine the conditions that caused the overvoltage condition.

#### Expected Result:

An overvoltage was caused by an occurrence that is known to the operator and the operator would like to put the genset back into service.

#### Results:

- OK – The operator can determine the cause for the overvoltage condition, the condition has been repaired and the operator wants to put the genset back into service.

**Repair:** Reset the genset. Resume normal operation and verify that the problem has been corrected.

STOP.

- NOT OK – The overvoltage condition was not caused by an occurrence that is known to the operator. Proceed to Test Step 2

**Test Step 2. CHECK THE SETPOINTS.**

- A. View the Generator Overvoltage setpoints. Make a note of the setpoints. See Testing and Adjusting, "Electronic Control Module (Generator Set) - Configure". Compare the setpoints against the default setpoints of the particular generator set.

**Expected Result:**

The setpoints are correct.

**Results:**

- OK – The setpoints are correct for your particular genset.

**Repair:** Reset the genset. Resume normal operation and verify that the problem has been corrected.

STOP.

- NOT OK – The setpoints are NOT correct.

**Repair:** Reprogram the setpoints. Reset the genset. Resume normal operation and verify that the problem has been corrected.

STOP.

**Test Step 3. VERIFY VOLTAGE CAN BE ADJUSTED**

Verify the generator output voltage can be adjusted from the EMCP 3 Display Screen.

**Expected Result:**

The generator output voltage can be adjusted from the EMCP 3 Display Screen.

**Results:**

- OK – The generator output voltage can be changed from the EMCP 3 Display Screen.

**Repair:** Adjust the generator output voltage to meet site requirements. Resume normal operation and verify that the problem has been corrected.

STOP.

- NOT OK – The generator output voltage cannot be adjusted. Proceed to test step 4

**Test Step 4. CHECK CAT DATA LINK BETWEEN THE EMCP 3 AND THE VOLTAGE REGULATOR**

Refer to the Genset Electrical System Schematic in the Service Manual and check the Data Link wiring between the EMCP 3 and the Voltage Regulator. For more information on troubleshooting the Data Link, see Troubleshooting , "Data Link Circuit Fault".

**Results:**

- OK – The Data Link wiring is correct.

**Repair:** Refer to the appropriate voltage regulator service manual and perform an operational check of the voltage regulator. Replace the voltage regulator if necessary. Resume normal operation and verify that the problem has been corrected.

STOP.

- NOT OK – The wiring is not correct

**Repair:** Repair the Data Link wiring or Replace the Data Link wiring. Resume normal operation and verify that the problem has been corrected.

STOP.

i02464689

**Generator Reverse Power Warning**

**SMCS Code:** 4490

**System Operation Description:**

If the current rises above the Generator Reverse Power Percentage Threshold setpoint value, then the reverse power timer will begin timing. When the timer expires, the Generator Reverse Power event is made active (if the current has been above the threshold level continuously while timing). If the current drops below the Generator Reverse Power Percentage Threshold, then the Generator Reverse Power event will be made inactive and the timer will be reset.

If a reverse power condition is detected, "GEN REVERSE POWER SHUTDOWN" or "GEN REVERSE POWER WARNING" will be displayed on the EMCP 3 in order to inform the operator of a reverse power condition.

**Note:** The severity of the reverse power condition will determine if a warning or shutdown event occurs.

**Conditions Which Generate This Code:**

The code for generator reverse power is generated when the EMCP 3 determines that a generator reverse power condition has occurred.

### Test Step 1. TALK TO THE OPERATOR

**A.** Determine the conditions that caused the reverse power condition.

**Expected Result:**

A reverse power was caused by an occurrence known to the operator and the operator would like to put the genset back into service.

**Results:**

- OK – The operator can determine the cause for the reverse power condition, the condition has been repaired and the operator wants to put the genset back into service.

**Repair:** Reset the genset. Resume normal operation and verify that the problem has been corrected.

STOP.

- NOT OK – The reverse power condition was not caused by an occurrence known to the operator. Proceed to Test Step 2

### Test Step 2. CHECK THE SETPOINTS.

**A.** View the Generator Reverse Power setpoints. Make a note of the setpoints. See Testing and Adjusting, "Electronic Control Module (Generator Set) - Configure". Compare the setpoints against the default setpoints of the particular generator set.

**Expected Result:**

The setpoints are correct.

**Results:**

- OK – The setpoints are correct for your particular genset. Proceed to Test Step 3.
- NOT OK – The setpoints are NOT correct.

**Repair:** Reprogram the setpoints. Reset the genset. Resume normal operation and verify that the problem has been corrected.

STOP.

### Test Step 3. CHECK THE POLARITY OF THE CURRENT TRANSFORMERS

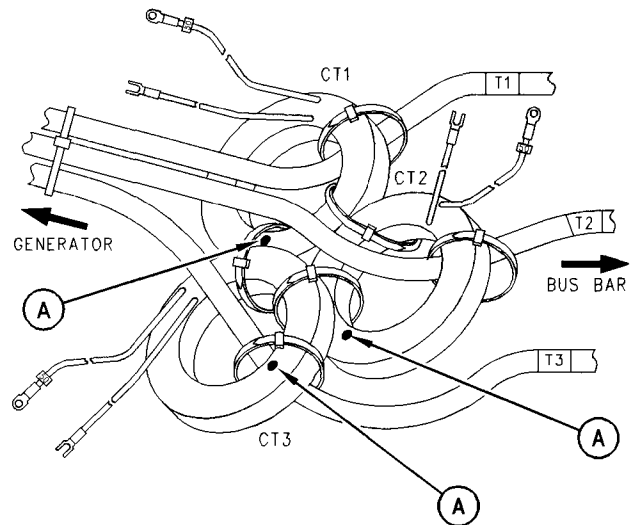

Illustration 17

g00607036

(A) Current Transformer Polarity Dot

**A.** Press the STOP key in order to shut down the engine.

**B.** Check the polarity of the current transformers. The polarity dots on all of the transformers should be towards the genset. Refer to Illustration 17.

**Expected Result:**

The polarity of the current transformers should be correct.

**Results:**

- OK – The polarity of the current transformers is correct.

**Repair:** It is unlikely that the EMCP 3 has failed. Exit this procedure and perform this procedure again. If the diagnostic code is still present, then replace the EMCP 3. Refer to Testing and Adjusting, "Electronic Control Module (Generator Set) - Replace".

STOP.

- NOT OK – The polarity of the current transformers is NOT correct.

**Repair:** Install the current transformers as shown on the wiring diagram for your particular genset. Reset the genset. Resume normal operation and verify that the problem has been corrected.

STOP.

i02464681

## Generator Underfrequency Warning

**SMCS Code:** 4490

### System Operation Description:

If the frequency drops below the Generator Underfrequency Percentage Threshold setpoint value, then the underfrequency timer will begin timing. When the timer expires, then the Generator Underfrequency event is made active (if the frequency has been below the threshold level continuously while timing). If the frequency rises above the Generator Underfrequency Percentage Threshold, then the Generator Underfrequency event will be made inactive and the timer will be reset.

If an underfrequency condition is detected, then "GEN UNDERFREQUENCY SHUTDOWN" or "GEN UNDERFREQUENCY WARNING" will be displayed on the EMCP 3 in order to inform the operator of an underfrequency condition.

**Note:** The severity of the underfrequency condition will determine if a warning or shutdown event occurs.

### Conditions Which Generate This Code:

The code for generator underfrequency is generated when the EMCP 3 determines that a generator underfrequency condition has occurred.

### Test Step 1. TALK TO THE OPERATOR

**A.** Determine the conditions that caused the underfrequency condition.

#### Expected Result:

An underfrequency condition was caused by an occurrence that is known to the operator and the operator would like to put the genset back into service.

#### Results:

- OK – The operator can determine the cause for the underfrequency condition, the condition has been repaired and the operator wants to put the genset back into service.

**Repair:** Reset the genset. Resume normal operation and verify that the problem has been corrected.

STOP.

- NOT OK – The underfrequency condition was not caused by an occurrence known to the operator. Proceed to Test Step 2

### Test Step 2. CHECK THE SETPOINTS.

**A.** View the Generator Underfrequency and Generator Desired Engine Speed Request setpoints. Make a note of the setpoints. See Testing and Adjusting, "Electronic Control Module (Generator Set) - Configure". Compare the setpoints against the default setpoints of the particular generator set.

#### Expected Result:

The setpoints are correct.

#### Results:

- OK – The setpoints are correct for your particular genset. Proceed to test step 3 for EUI engines. Proceed to test step 4 for MUI engines
- NOT OK – The setpoints are NOT correct.

**Repair:** Reprogram the setpoints. Reset the genset. Resume normal operation and verify that the problem has been corrected.

STOP.

### Test Step 3. VERIFY FREQUENCY CAN BE VIEWED AND ADJUSTED FROM THE EMCP 3 (EUI ENGINES ONLY)

Verify the generator output frequency can be viewed and adjusted from the EMCP 3 Display Screen.

#### Expected Result:

The generator output frequency can be viewed and adjusted from the EMCP 3 Display Screen.

#### Results:

- OK – The generator output frequency can be viewed and adjusted from the EMCP 3 Display Screen.

**Repair:** Adjust the generator output frequency to meet site requirements. Resume normal operation and verify that the problem has been corrected.

STOP.

- NOT OK – The generator output frequency cannot be adjusted. Proceed to test step 7
- NOT OK – The generator frequency reads zero on the EMCP Display Screen. Proceed to test step 8

**Test Step 4. CHECK THE SYSTEM BY USING THE SPEED POTENTIOMETER. (MUI ENGINES ONLY)**

- A. With the engine running, adjust the generator output frequency by turning the speed potentiometer.

**Expected Result:**

The generator output can be adjusted to the desired frequency.

**Results:**

- OK – The generator output frequency can be adjusted.

**Repair:** Adjust the generator output frequency to meet site requirements. Resume normal operation and verify that the problem has been corrected.

STOP.

- NOT OK – The generator output frequency cannot be adjusted with the speed potentiometer. Proceed to test step 5

**Test Step 5. CHECK THE RESISTANCE OF THE ENGINE SPEED POTENTIOMETER. (MUI ENGINES ONLY)**

- A. Disconnect the speed potentiometer from the terminals “11” and “12” on the 2301A Governor.
- B. At the speed potentiometer, measure the resistance of the speed potentiometer.

**Expected Result:**

The resistance should be adjustable between 0 and 100 ohms.

**Results:**

- OK – The resistance of the sensor is correct. Proceed to Test Step 6.
- NOT OK – The resistance of the speed potentiometer is not correct.

**Repair:** Replace the speed potentiometer. Resume normal operation and verify that the problem has been corrected.

STOP.

**Test Step 6. CHECK THE SPEED POTENTIOMETER HARNESS FOR AN OPEN CIRCUIT. (MUI ENGINES ONLY)**

- A. Disconnect the speed potentiometer harness from the 2301A governor.
- B. Check for an open circuit. Check the resistance from the wire connected to terminal “11” of the 2301A governor to the same wire number at the speed potentiometer. The resistance should be 5 ohms or less.
- C. Check for an open circuit. Check the resistance from the wire connected to terminal “12” of the 2301A governor to the same wire number at the speed potentiometer. The resistance should be 5 ohms or less

**Expected Result:**

When the resistance is measured between the wire connected to terminal “11” of the 2301A governor to the same wire number at the speed potentiometer connector, the resistance should be 5 ohms or less.

When the resistance is measured between the wire connected to terminal “12” of the 2301A governor to the same wire number at the speed potentiometer connector, the resistance should be 5 ohms or less.

**Results:**

- OK – The harness functions properly. Proceed to test step 8
- NOT OK – The harness wiring with the incorrect resistance measurement has failed. Replace the failed harness from the 2301A governor to the speed potentiometer or repair the failed harness from the 2301A governor to the speed potentiometer. Resume normal operation and verify that the problem has been corrected. STOP.

**Test Step 7. CHECK J1939 DATA LINK BETWEEN THE EMCP 3 AND THE ENGINE ECM (EUI ENGINES ONLY)**

Refer to the Genset Electrical System Schematic in the Service Manual and check the Data Link wiring between the EMCP 3 and the Engine ECM. For more information on troubleshooting the Data Link, see Troubleshooting , “Data Link Circuit Fault ”.

**Results:**

- OK – The J1939 Data Link wiring is correct. Proceed to test step 8
- NOT OK – The wiring is not correct

**Repair:** Repair the Data Link wiring or Replace the Data Link wiring. Resume normal operation and verify the problem has been corrected.

STOP.

**Test Step 8. CHECK THE VOLTAGE INPUT FUSES.**

- A.** Check the three fuses on the AC voltage inputs of the EMCP 3.

**Expected Result:**

The fuses should not be open.

**Results:**

- OK – The fuses are not open. Proceed to test step 9
- NOT OK – One or more of the fuses are open.

**Repair:** Check for a shorted component or damaged wiring. Troubleshoot and repair the problem. See the Generator Set Wiring Diagram for your particular genset. After the problem has been repaired, replace the fuses.

STOP.

**Test Step 9. CHECK THE GENERATOR VOLTAGE OUTPUT.**

- A.** Open the circuit breaker or remove the load.
- B.** Start the engine and run the genset.
- C.** Measure the voltage between all three AC input fuses.

**Expected Result:**

The line to line voltage should measure the rated voltage of the genset.

**Results:**

- OK – The voltages are correct and the problem remains. Proceed to Test Step 10.
- NOT OK – One or more of the voltages are NOT correct.

**Repair:** The wiring or the connections the are damaged. Check for damaged wiring between the fuses and the generator output bus. See the Generator Set Wiring Diagram for your particular genset. Repair the wiring or replace the wiring. Resume normal operation and verify the problem has been corrected.

STOP.

**Test Step 10. CHECK THE VOLTAGE INPUT CONNECTIONS**

- A.** Shut down the engine.
- B.** Remove the EMCP 3 harness connector from the EMCP 3.
- C.** Check the EMCP 3 harness connector. See Testing And Adjusting, "Electrical Connector - Inspect".
- D.** Check for one or more damaged wires between the EMCP 3 voltage inputs and the voltage input fuses. See the Generator Set Wiring Diagram for your particular genset.

**Expected Result:**

The wiring and the connectors should have been good.

**Results:**

- OK – NO problem was found with the connectors or with the wiring.

**Repair:** The EMCP 3 may have failed. It is unlikely that the EMCP 3 has failed. Exit this procedure and perform this entire procedure again. If the problem remains, replace the EMCP 3. See Testing And Adjusting, " Electronic Control Module (Generator Set) - Replace".

STOP.

- NOT OK – The problem was with the connectors or with the wiring.

**Repair:** Repair the connectors or replace the wiring harness. Resume normal operation and verify that the problem has been corrected.

STOP.

i02464667

## Generator Undervoltage Warning

**SMCS Code:** 4490

### System Operation Description:

If the voltage drops below the Generator Undervoltage Percentage Threshold and Automatic Voltage Regulator (AVR) Request setpoint value, the undervoltage timer will begin timing. When the timer expires, the Generator Undervoltage event is made active (if the frequency has been below the threshold level continuously while timing). If the voltage rises above the Generator Undervoltage Percentage Threshold, the Generator Undervoltage event will be made inactive and the timer will be reset.

If an undervoltage condition is detected, "GEN UNDERVOLTAGE SHUTDOWN" or "GEN UNDERVOLTAGE WARNING" will be displayed on the EMCP 3 in order to inform the operator of an undervoltage condition.

**Note:** The severity of the undervoltage condition will determine if a warning or shutdown event occurs.

### Conditions Which Generate This Code:

The code for generator undervoltage is generated when the EMCP 3 determines that a generator undervoltage condition has occurred.

### Test Step 1. TALK TO THE OPERATOR

- A.** Determine the conditions that caused the undervoltage condition.

#### Expected Result:

An undervoltage was caused by an occurrence known to the operator and the operator would like to put the genset back into service.

#### Results:

- OK – The operator can determine the cause for the undervoltage condition, the condition has been repaired and the operator wants to put the genset back into service.

**Repair:** Reset the genset. Resume normal operation and verify that the problem has been corrected.

STOP.

- NOT OK – The undervoltage condition was not caused by an occurrence known to the operator. Proceed to Test Step 2

### Test Step 2. CHECK THE SETPOINTS.

- A.** View the Generator Undervoltage, Automatic Voltage Regulator (AVR) Desired Voltage Request, and Generator AC Monitor setpoints. Make a note of the setpoints. See Testing and Adjusting, "Electronic Control Module (Generator Set) - Configure". Compare the setpoints against the default setpoints of the particular generator set.

#### Expected Result:

The setpoints are correct.

#### Results:

- OK – The setpoints are correct for your particular genset. Proceed to test step 3
- NOT OK – The setpoints are NOT correct.

**Repair:** Reprogram the setpoints. Reset the genset. Resume normal operation and verify that the problem has been corrected.

STOP.

### Test Step 3. VERIFY VOLTAGE CAN BE ADJUSTED

Verify the generator output voltage can be adjusted from the EMCP 3 Display Screen.

#### Expected Result:

The generator output voltage can be adjusted from the EMCP 3 Display Screen.

#### Results:

- OK – The generator output voltage can be changed from the EMCP 3 Display Screen.

**Repair:** Adjust the generator output voltage to meet site requirements. Resume normal operation and verify that the problem has been corrected.

STOP.

- NOT OK – The generator output voltage cannot be adjusted. Proceed to test step 4

#### **Test Step 4. CHECK CAT DATA LINK BETWEEN THE EMCP 3 AND THE VOLTAGE REGULATOR**

Refer to the Genset Electrical System Schematic in the Service Manual and check the Data Link wiring between the EMCP 3 and the Voltage Regulator. For more information on troubleshooting the Data Link, see Troubleshooting , "Data Link Circuit Fault ".

##### **Results:**

- OK – The Data Link wiring is correct. Proceed to test step 5
- NOT OK – The wiring is not correct

**Repair:** Repair the Data Link wiring or Replace the Data Link wiring. Resume normal operation and verify the problem has been corrected.

STOP.

#### **Test Step 5. VERIFY VOLTAGE SENSING CIRCUITS**

Verify all three phases of generator output voltage are shown on the EMCP 3 Display Screen.

##### **Expected Result:**

All three phases of generator output voltage are shown on the EMCP 3 Display Screen

##### **Results:**

- OK – All three phases of generator output voltage are shown on the EMCP 3 Display Screen

**Repair:** Refer to appropriate voltage regulator service manual and perform an operational check of the voltage regulator. Resume normal operation and verify that the problem has been corrected.

STOP.

- NOT OK – All phases of voltage are not shown on display. Proceed to test step 6

#### **Test Step 6. CHECK THE VOLTAGE INPUT FUSES.**

- A. Check the three fuses on the AC voltage inputs of the EMCP 3.

##### **Expected Result:**

The fuses should not be open.

##### **Results:**

- OK – The fuses are not open. Proceed to test step 7

- NOT OK – One or more of the fuses are open.

**Repair:** Check for a shorted component or damaged wiring. Troubleshoot and repair the problem. See the Generator Set Wiring Diagram for your particular genset. After the problem has been repaired, replace the fuses.

STOP.

#### **Test Step 7. CHECK THE GENERATOR VOLTAGE OUTPUT.**

- A. Open the circuit breaker or remove the load.

- B. Start the engine and run the genset.

- C. Measure the voltage between all three AC input fuses.

##### **Expected Result:**

The line to line voltage should measure the rated voltage of the genset.

##### **Results:**

- OK – The voltages are correct and the problem remains. Proceed to Test Step 8.
- NOT OK – One or more of the voltages are NOT correct.

**Repair:** The wiring or the connections the are damaged. Check for damaged wiring between the fuses and the generator output bus. See the Generator Set Wiring Diagram for your particular genset. Repair the wiring or replace the wiring. Resume normal operation and verify that the problem has been corrected.

STOP.

#### **Test Step 8. CHECK THE VOLTAGE INPUT CONNECTIONS**

- A. Shut down the engine.

- B. Remove the EMCP 3 harness connector from the EMCP 3.

- C. Check the EMCP 3 harness connector. See Testing And Adjusting, "Electrical Connector - Inspect".

- D. Check for one or more damaged wires between the EMCP 3 voltage inputs and the voltage input fuses. See the Generator Set Wiring Diagram for your particular genset.

**Expected Result:**

The wiring and the connectors should have been good.

**Results:**

- OK – NO problem was found with the connectors or with the wiring.

**Repair:** The EMCP 3 may have failed. It is unlikely that the EMCP 3 has failed. Exit this procedure and perform this entire procedure again. If the problem remains, replace the EMCP 3. See Testing And Adjusting, “Electronic Control Module (Generator Set) - Replace”.

STOP.

- NOT OK – The problem was with the connectors or with the wiring.

**Repair:** Repair the connectors or replace the wiring harness. Resume normal operation and verify that the problem has been corrected.

STOP.

i02464635

## Service Maintenance Interval Warning

**SMCS Code:** 4490

**System Operation Description:**

A Service Maintenance Interval Warning event is detected when the number of engine hours or the number of days since the previous alarm occurrence was reset exceeds the number of hours or days specified by the Service Interval Setpoints. Once the event is active, it will not become inactive until a Reset Service Interval Counter Command is received over the data link or from the display.

**Conditions Which Generate This Code:**

The Service Maintenance Interval code is generated when the EMCP 3 determines a need for engine service based on engine hours or the number of days since last service, whichever occurs first.

### Test Step 1. Talk to the Operator

- A. Determine the conditions that caused the diagnostic code.

**Expected Result:**

Genset maintenance records indicate that the maintenance interval has been exceeded and maintenance is required

**Results:**

- OK – Records indicate service is required. Perform the required maintenance and reset the Service Maintenance Interval in order to indicate when the genset will need to be serviced again. STOP.
- NOT OK – Records indicate service is not required. Proceed to Test Step 2

### Test Step 2. CHECK THE SETPOINTS.

- A. View the setpoints (Service Maintenance Interval Hours), and (Service Maintenance Interval Days) and make note of the setpoints. See Testing and Adjusting, “Electronic Control Module (Generator Set) - Configure”. Compare the setpoints against the default setpoints of the particular generator set.

**Expected Result:**

The setpoints are correct for your particular genset and application.

**Results:**

- OK – The setpoints are correct for your particular genset and application.

**Repair:** It is possible the Service Maintenance Interval was not reset when the genset was last serviced. Reset the Service Maintenance Interval in order to indicate when the genset will need to be serviced again. Resume normal operation.

STOP.

- NOT OK – The setpoints are NOT correct for your particular genset and application.

**Repair:** Reprogram the setpoints. Reset the genset. Resume normal operation and verify that the problem has been corrected.

STOP.

102463493

## Analog Input Circuit Fault

**SMCS Code:** 4490

### System Operation Description:

Spare Analog Inputs are connected to resistive type sensors either on the engine, generator, or supporting systems. The EMCP 3 converts the resistive sensor values into levels, temperatures, and pressures depending on how the input is configured. Six programmable thresholds are provided. These thresholds include both high and low for each of the three supported data types. The appropriate thresholds are selected based on the Spare Analog Input Type Configuration setpoints. The EMCP 3 will also detect sensor diagnostics for shorted high and shorted low conditions.

An active spare analog input can be programmed to cause an alarm or a shutdown. For programming of the spare inputs, see System Operation, "Spare Analog Input Programming".

### Conditions Which Generate This Code:

This code is generated when the measured Spare Analog Input value goes above or below the programmed threshold for a configurable duration.

### Test Step 1. PERFORM THE INITIAL CHECK.

- A.** Use the Caterpillar Electronic Technician in order to check for active diagnostic codes on the Engine ECM. If any codes are present, then correct the diagnostic codes first.

#### Expected Result:

No other diagnostic codes or indicators are active on the engine ECM.

#### Results:

- OK – No other diagnostic codes or indicators are active. Proceed to Test Step 2
- NOT OK – Another Engine ECM diagnostic code is active.

**Repair:** Exit this procedure. Troubleshoot the active code or indicator. Refer to the engine Troubleshooting manual for your particular genset.

STOP.

### Test Step 2. CHECK THE SETPOINTS.

- A.** View the Spare Analog Input setpoints. Make a note of the setpoints. See Testing and Adjusting, "Electronic Control Module (Generator Set) - Configure". Compare the setpoints against the default setpoints of the particular generator set.

#### Expected Result:

The setpoints are correct.

#### Results:

- OK – The setpoints are correct for your particular genset. Proceed to test step 3
- NOT OK – The setpoints are NOT correct.

**Repair:** Reprogram the setpoints. Reset the genset. Resume normal operation and verify that the problem has been corrected.

STOP.

### Test Step 3. CHECK THE ANALOG INPUT DEVICE WIRING

- A.** Check the wiring to the corresponding spare analog input for an unwanted short circuit. The short can be to the battery negative ("B-"). The short can be to the battery positive terminal ("B+"). Carefully check ALL wires that are connected to the appropriate analog input for abrasion or worn spots in the insulation that could be causing the short. Check the wires in the generator control panel. Check the wires in the engine harness. Refer to the appropriate wiring diagrams for the circuit that is being checked.

#### Expected Result:

The wiring is correct.

#### Results:

- OK – No problems can be found with the analog input wiring. Proceed to test step 4
- NOT OK – The analog input wiring is defective.

**Repair:** Repair the wiring or replace the wiring.

Proceed to test step 4

### Test Step 4. CHECK IF THE DIAGNOSTIC CODE REMAINS

- A.** Inspect the harness connectors and clean the contacts of the harness connectors.
- B.** Reconnect all harness connectors.

- C. Reset the genset.
- D. Operate the genset.
- E. Check the status of the diagnostic code.

**Expected Result:**

The diagnostic code is not active.

**Results:**

- OK – The diagnostic code is not active. The diagnostic code does not exist at this time. The initial diagnostic code was probably caused by a poor connection or a short at one of the connectors that was disconnected and reconnected. Resume normal operation. STOP.
- NOT OK – The code is active. The diagnostic code has not been corrected. The ECM may have failed.

**Repair:** It is unlikely that the ECM has failed. Exit this procedure and perform this procedure again. If the cause of the failure is not found, replace the ECM. See Testing and Adjusting, “Electronic Control Module (Generator Set) - Replace”.

STOP.

i02463497

## Charging System

**SMCS Code:** 1401; 1405

**System Operation Description:**

The EMCP 3 monitors its battery supply voltage based on the +BATT and –BATT voltage inputs to the EMCP 3 control. If the battery voltage rises above the High Battery Voltage Event Threshold setpoint value, the high battery voltage event timer will begin timing. When the high battery voltage timer expires, the High Battery Voltage event is made active (if the battery voltage has been above the event threshold level continuously while timing). If the battery voltage drops below the High Battery Voltage Warning Threshold, the High Battery Voltage event will be made inactive and the timer will be reset.

If a battery overvoltage condition is detected, “HIGH BATTERY VOLTAGE SHUTDOWN” or “HIGH BATTERY VOLTAGE WARNING” will be displayed on the EMCP 3 in order to inform the operator of a high battery voltage condition.

If the battery voltage drops below the Low Battery Voltage Warning Threshold setpoint value, the low battery voltage event timer will begin timing. When the low battery voltage event timer expires, the Low Battery Voltage event is made active (if the battery voltage has been below the event threshold level continuously while timing). If the battery voltage rises above the Low Battery Voltage Event Threshold, the Low Battery Voltage event will be made inactive and the timer will be reset.

If a battery undervoltage condition is detected, “LOW BATTERY CHARGING SYS VOLT WARN” or “LOW BATTERY VOLTAGE WARNING” will be displayed on the EMCP 3 in order to inform the operator of an undervoltage condition.

**Note:** The severity of the battery over/under voltage condition will determine if a warning or shutdown event occurs.

**Conditions Which Generate This Code:**

This code is generated when the measured battery voltage value goes above or below the programmed thresholds for a configurable duration.

### Test Step 1. PERFORM THE INITIAL CHECK.

- A. The battery and charging system are located on the engine. Use the Caterpillar Electronic Technician in order to check for active diagnostic codes on the Engine ECM. If any codes are present, correct the engine diagnostic codes first.

**Expected Result:**

No other diagnostic codes or indicators are active on the Engine ECM.

**Results:**

- OK – No other diagnostic codes or indicators are active. 2
- NOT OK – Another Engine ECM diagnostic code is active.

**Repair:** Exit this procedure. Troubleshoot the active code or indicator. Refer to the engine Troubleshooting manual for your particular genset.

STOP.

**Test Step 2. CHECK THE SETPOINTS.**

- A. View the Battery Voltage Monitor setpoints. Make a note of the setpoints. See Testing and Adjusting, "Electronic Control Module (Generator Set) - Configure". Compare the setpoints against the default setpoints of the particular generator set.

**Expected Result:**

The setpoints are correct.

**Results:**

- OK – The setpoints are correct for your particular genset. Proceed to test step 3
- NOT OK – The setpoints are NOT correct.

**Repair:** Reprogram the setpoints. Reset the genset. Resume normal operation and verify that the problem has been corrected.

STOP.

**Test Step 3. COMPARE ACTUAL BATTERY VOLTAGE TO THE VOLTAGE DISPLAYED ON THE EMCP 3 DISPLAY**

- A. Shut down the engine.
- B. Disconnect the harness connector from the EMCP 3.
- C. At the harness connector, measure the battery voltage between pin number 52 and pin number 65.

**Expected Result:**

The measured battery voltage should be the same as the battery voltage displayed on the EMCP 3 display screen.

**Results:**

- OK – The measured battery voltage is the same as the battery voltage displayed on the EMCP 3 Display Screen. Proceed to test step 4
- NOT OK – The measured battery voltage is not the same as the battery voltage displayed on the EMCP 3 Display Screen. The EMCP 3 may have failed.

**Repair:** It is unlikely that the EMCP 3 has failed. Exit this procedure and perform this procedure again. If the cause of the failure is not found, replace the EMCP 3. See Testing and Adjusting, "Electronic Control Module (Generator Set) - Replace".

STOP.

**Test Step 4. CHECK THE BATTERY VOLTAGE WIRING BETWEEN THE EMCP 3 AND THE BATTERY SOURCE**

- A. Check the battery negative ("B-") wiring to the battery negative input for a short circuit or open circuit. Check the battery positive ("B+") wiring to the battery positive input for a short circuit or open circuit. Check the wires in the generator control panel. Check the wires in the engine harness. Refer to the appropriate wiring diagrams for the circuit that is being checked.

**Expected Result:**

The wiring is correct.

**Results:**

- OK – No problems can be found with the battery voltage supply wiring. Proceed to test step 5
- NOT OK – The battery voltage supply wiring is defective.

**Repair:** Repair the wiring or replace the wiring.

Proceed to test step 5

**Test Step 5. CHECK IF THE DIAGNOSTIC CODE REMAINS**

- A. Inspect the harness connectors and clean the contacts of the harness connectors.
- B. Reconnect all harness connectors.
- C. Reset the genset.
- D. Operate the genset.
- E. Check the status of the diagnostic code.

**Expected Result:**

The diagnostic code is not active.

**Results:**

- OK – The diagnostic code is not active. The diagnostic code does not exist at this time. The initial diagnostic code was probably caused by a poor connection or a short at one of the connectors that was disconnected and reconnected. Resume normal operation. STOP.
- NOT OK – The code is active. The diagnostic code has not been corrected. The ECM may have failed.

**Repair:** It is unlikely that the ECM has failed. Exit this procedure and perform this procedure again. If the cause of the failure is not found, replace the ECM. See Testing and Adjusting, "Electronic Control Module (Generator Set) - Replace".

STOP.

i02463551

## Data Link Circuit Fault

**SMCS Code:** 4490

### System Operation Description:

This procedure checks for an open circuit or a short circuit in a Data Link. There are three data links associated with the EMCP 3.

- J1939 Accessory Data Link
- J1939 Primary Data Link
- Modbus RS-485 SCADA Data Link

Refer to Systems Operation, "General Information" for details on each data link.

**Note:** Use the wiring diagram for your particular genset in order to troubleshoot the Data Links.

### Test Step 1. Inspect the Electrical Connectors and the Wiring

- A. Turn the keyswitch to the OFF position.
- B. Thoroughly inspect the EMCP 3 connector, the service tool connector, and all other connectors in the circuit for the data link.

**Reference:** Refer to Troubleshooting, "Electrical Connectors - Inspect" for details.

#### Expected Result:

All connectors, pins, and sockets are completely inserted and coupled. The harness and wiring are free of corrosion, of abrasion, and of pinch points.

#### Results:

- OK – In order to troubleshoot the Modbus RS-485 SCADA Data Link, proceed to Test Step 2
- OK – In order to troubleshoot the J1939 Primary or the J1939 Accessory Data Link, proceed to Test Step 4
- Not OK

**Repair:** Repair the wiring or replace the wiring.

STOP.

### Test Step 2. Check for Shorts in the Modbus RS-485 SCADA Data Link Harness

- A. Disconnect all connectors from the suspected data link.
- B. Measure the resistance between (data link +) and data link -).
- C. Measure the resistance between ( data link +) and chassis ground.
- D. Measure the resistance between ( data link -) and chassis ground.

#### Expected Result:

The resistance is greater than 20,000 Ohms for each measurement.

#### Results:

- OK – Proceed to Test Step 5
- Not OK – There is a short circuit in the harness or connectors.

**Repair:** Repair the wiring or replace the wiring.

Proceed to Test Step 5

### Test Step 3. Check the Resistance through the Modbus RS-485 SCADA Data Link Harness

- A. Disconnect all connectors from the suspected data link.
- B. Use a suitable piece of wire to short (Data Link +) and ( Data Link -) at the EMCP 3.
- C. Measure the resistance between (Data Link +) and (Data Link -) at all other connectors in the circuit for the data link.

#### Expected Result:

The resistance is less than 10 Ohms.

#### Results:

- OK – The Data Link is OK. Proceed to test step 5
- Not OK – There is an open circuit or excessive resistance in the harness or connectors.

**Repair:** Repair the wiring or replace the wiring.

Proceed to Test Step 5

#### Test Step 4. Check for Shorts in the J1939 Data Link Harness

- A.** Disconnect all connectors from the suspected data link.
- B.** Measure the resistance between (data link +) and data link -).

##### Expected Result:

The resistance is approximately 60 Ohms.

##### Results:

- OK – Proceed to Test Step 5.
- Not OK – If the resistance is approximately 120 ohms, a termination resistor is missing. If the resistance is much greater than 120 ohms, both termination resistors are missing or there is an open data link circuit. If the resistance is much less than 60 ohms, there is a short circuit

**Repair:** Repair the wiring or replace the wiring.

Proceed to Test Step 5

#### Test Step 5. CHECK IF THE DIAGNOSTIC CODE REMAINS

- A.** Inspect the Data Link harness connectors and clean the contacts of the harness connectors.
- B.** Reconnect all Data Link harness connectors.
- C.** Reset the genset.
- D.** Operate the genset.
- E.** Check the status of the diagnostic code.

##### Expected Result:

The diagnostic code is not active.

##### Results:

- OK – The diagnostic code is not active. The diagnostic code does not exist at this time. The initial diagnostic code was probably caused by a poor connection or a short at one of the connectors that was disconnected and reconnected. Resume normal operation. STOP.
- NOT OK – The code is active. The diagnostic code has not been corrected. The ECM may have failed.

**Repair:** It is unlikely that the ECM has failed. Exit this procedure and perform this procedure again. If the cause of the failure is not found, replace the ECM. See Testing and Adjusting, “Electronic Control Module (Generator Set) - Replace”.

STOP.

i02463502

## Digital Input Circuit Fault

**SMCS Code:** 4490

### System Operation Description:

Digital inputs are used to bring on/off information, such as switch closures, to the Genset Control. Depending on how the input is programmed, the EMCP 3 associates the inputs with levels, temperatures, pressures, and status conditions. Two of the Digital Inputs, which are programmed at the factory, are used by the EMCP 3 to control Emergency Stop and Remote Initiate functions. The spare digital inputs must be programmed before use.

For additional information on programming digital inputs, see System Operation, “Digital Input Programming”

### Conditions Which Generate This Code:

This code is generated when the digital input is active. The code may indicate that a problem exists with the genset, or the code may indicate a status that does not need to be repaired.

### Test Step 1. PERFORM THE INITIAL CHECK.

- A.** Use the Caterpillar Electronic Technician in order to check for active diagnostic codes on the Engine ECM. If any codes are present, correct the diagnostic codes first.

##### Expected Result:

No other diagnostic codes or indicators are active on the Engine ECM.

##### Results:

- OK – No other diagnostic codes or indicators are active. Proceed to Test Step 2
- NOT OK – Another Engine ECM diagnostic code is active.

**Repair:** Exit this procedure. Troubleshoot the active code or indicator. Refer to the engine Troubleshooting manual for your particular genset.

STOP.

### Test Step 2. CHECK THE SETPOINTS.

- A. View the Digital Input setpoints. Make a note of the setpoints. See Testing and Adjusting, "Electronic Control Module (Generator Set) - Configure". Compare the setpoints against the default setpoints of the particular generator set.

**Expected Result:**

The setpoints are correct.

**Results:**

- OK – The setpoints are correct for your particular genset. Proceed to Test Step 3
- NOT OK – The setpoints are NOT correct.

**Repair:** Reprogram the setpoints. Reset the genset. Resume normal operation and verify that the problem has been corrected.

STOP.

### Test Step 3. CHECK THE DIGITAL INPUT WIRING

- A. Check the wiring to the corresponding digital inputs for an unwanted short circuit. The short can be to the battery negative ("B-"). Carefully check ALL wires that are connected to the appropriate digital input for abrasion or worn spots in the insulation that could be causing the short. Check the wires in the generator control panel. Check the wires in the engine harness. Refer to the appropriate wiring diagrams for the circuit that is being checked.

**Expected Result:**

The wiring is correct.

**Results:**

- OK – No problems can be found with the digital input wiring. Proceed to test step 4
- NOT OK – The digital input wiring is defective.

**Repair:** Repair the wiring or replace the wiring.

Proceed to test step 4

### Test Step 4. CHECK IF THE DIAGNOSTIC CODE REMAINS

- A. Inspect the harness connectors and clean the contacts of the machine harness connectors.
- B. Reconnect all harness connectors.

- C. Reset the genset.

- D. Operate the genset.

- E. Check the status of the diagnostic code.

**Expected Result:**

The diagnostic code is not active.

**Results:**

- OK – The diagnostic code is not active. The diagnostic code does not exist at this time. The initial diagnostic code was probably caused by a poor connection or a short at one of the connectors that was disconnected and reconnected. Resume normal operation. STOP.
- NOT OK – The code is active. The diagnostic code has not been corrected. The ECM may have failed.

**Repair:** It is unlikely that the ECM has failed. Exit this procedure and perform this procedure again. If the cause of the failure is not found, then replace the ECM. See Testing and Adjusting, "Electronic Control Module (Generator Set) - Replace".

STOP.

i02464600

## Digital Output Circuit Fault

**SMCS Code:** 4490

**System Operation Description:**

Digital Outputs are used to convey on/off information from the Genset Control for energizing loads such as relays, solenoids, and indicator lamps. The digital output must not be connected directly to battery positive (B+).

**Conditions Which Generate This Code:**

This code is occurs when the digital output wiring is shorted to battery positive (B+).

### Test Step 1. CHECK FOR A SHORTED HARNESS

- A. Turn the key start switch and the disconnect switch to the OFF position.
- B. Disconnect the harness connector from the EMCP 3.
- C. Disconnect the digital output from the device it is connected to.

**D.** At the harness connector for the EMCP 3, measure the resistance from the failed digital output contact to all other EMCP 3 harness contacts.

**Expected Result:**

Each resistance measurement is greater than 5000 ohms.

**Results:**

- OK – Each resistance measurement is greater than 5000 ohms. The harness is correct. Proceed to Test Step 2
- NOT OK – Each resistance measurement is not greater than 5000 ohms. There is a short in the harness on the wire that has that has a low resistance measurement.

**Repair:** Repair the harness or replace the harness.

STOP.

**Test Step 2. CHECK THE DEVICE CONNECTED TO THE DIGITAL OUTPUT CIRCUIT WIRING FOR SHORT TO THE +BATTERY CIRCUIT.**

**A.** In order to prevent the engine from running while performing this procedure, press the Emergency Stop Push Button and turn the battery disconnect switch to the ON position.

**B.** At the digital output device, measure the DC voltage on the wire connected to the failed digital output.

**Expected Result:**

The voltage is at or near 0 volts DC and not shorted to battery positive (B+).

**Results:**

- OK – The digital output device is not shorted to battery positive (B+). Proceed to Test Step 3
- NOT OK – The digital output device is shorted to battery positive (B+)

**Repair:** Repair the digital output device or replace the digital output device.

STOP.

**Test Step 3. CHECK IF THE DIAGNOSTIC CODE REMAINS**

**A.** Inspect the EMCP 3 connector and clean the contacts of the EMCP 3 connector.

**B.** Reconnect the harness connector.

**C.** Reset the genset.

**D.** Operate the genset.

**E.** Check the status of the diagnostic code.

**Expected Result:**

The diagnostic code is not active.

**Results:**

- OK – The diagnostic code is not active. The diagnostic code does not exist at this time. The initial diagnostic code was probably caused by a poor connection or a short at one of the connectors that was disconnected and reconnected. Resume normal operation. STOP.
- NOT OK – The code is active. The diagnostic code has not been corrected. The ECM may have failed.

**Repair:** It is unlikely that the ECM has failed. Exit this procedure and perform this procedure again. If the cause of the failure is not found, replace the ECM. See Testing and Adjusting, "Electronic Control Module (Generator Set) - Replace".

STOP.

i02464543

## Engine Speed Circuit Fault

**SMCS Code:** 4490

**System Operation Description:**

The EMCP 3 performs the following using an independent engine speed sensor that is dedicated to EMCP 3 use only

- Determines the engine speed, in rpm, from the Magnetic Pickup (Engine Speed Sensor) input pins
- Detects diagnostics on the sensor
- Annunciates an engine over/under speed condition

The engine speed sensor is mounted on the flywheel housing of the engine.

The sensor creates a sine wave signal. The signal is created from passing ring gear teeth. The rate of the signal is one pulse per tooth. The sensor sends the sine wave signal to the EMCP 3. The frequency of the signal is directly proportional to the speed of the engine.

**Conditions Which Generate This Code:**

This code is generated when the EMCP 3 has determined that an incorrect signal from the engine speed sensor has occurred or an overspeed/underspeed condition has occurred.

**Refer to the engine Troubleshooting manual to for more information on engine over/under speed conditions for your particular genset.**

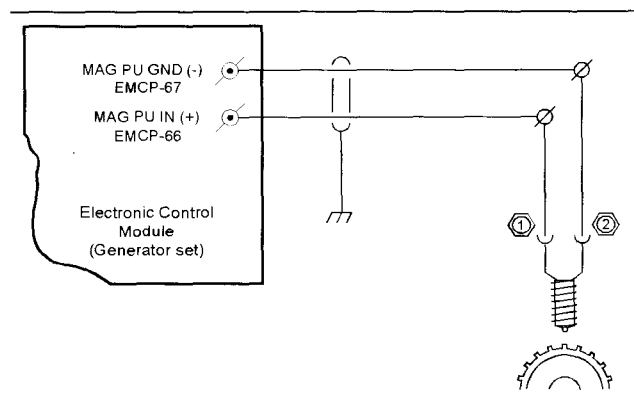

Illustration 18

g01103901

**Note:** The Engine Speed Sensor is commonly referred to as magnetic pickup.

### Test Step 1. PERFORM THE INITIAL CHECK.

- A. Check for active diagnostic codes on the engine ECM and the EMCP 3. If any codes are present, correct the diagnostic codes first.

#### Expected Result:

No other diagnostic codes or indicators are active.

#### Results:

- OK – No other diagnostic codes or indicators are active. Proceed to Test Step 2
- NOT OK – Another diagnostic code is active or an indicator is active.

**Repair:** Exit this procedure. Troubleshoot the active code or indicator. Resume normal operation and verify that the problem has been corrected.

STOP.

### Test Step 2. CHECK THE SETPOINTS.

- A. View the Engine Speed Monitor Setpoints. Make a note of all the setpoints. See Testing and Adjusting, “Electronic Control Module (Generator Set) - Configure”. Compare the setpoints against the default setpoints of the particular generator set.

#### Expected Result:

The setpoints are correct.

#### Results:

- OK – The setpoints are correct for your particular genset. Proceed to Test Step 3
- NOT OK – The setpoints are NOT correct.

**Repair:** Reprogram the setpoints. Reset the genset. Resume normal operation and verify that the problem has been corrected.

STOP.

### Test Step 3. CHECK THE HARNESS AND THE SPEED SENSOR.

- A. Press the **Stop** key on the EMCP 3 control.
- B. Disconnect the harness connector from the EMCP 3.
- C. At the EMCP 3 harness connector, measure the resistance from contact “66” to contact “67”.

#### Expected Result:

The resistance should be from 100 to 350 ohms.

#### Results:

- OK – There is probably an intermittent problem. Proceed to Test Step 4.
- NOT OK – The harness wiring or the speed sensor has failed. Proceed to Test Step 4.

### Test Step 4. CHECK FOR AN INTERMITTENT FAULT.

- A. Press the **Stop** key on the EMCP 3 control.
- B. Check the EMCP 3 display for a speed sensor diagnostic code.

#### Expected Result:

A speed sensor diagnostic code should not appear on the upper display.

#### Results:

- OK – A speed sensor diagnostic code does not appear on the EMCP 3 display. This step has corrected the problem. STOP.

- NOT OK – A speed sensor diagnostic code appears on the EMCP 3 display. Proceed to Test Step 5.

### **Test Step 5. CHECK THE RESISTANCE OF THE ENGINE SPEED SENSOR.**

- Disconnect the sensor from the engine harness. The sensor remains fastened to the engine.
- At the connector of the sensor, measure the resistance between contact “1” and contact “2”.

#### **Expected Result:**

The resistance should be between 100 to 350 ohms.

#### **Results:**

- OK – The resistance of the sensor is correct. Proceed to Test Step 6.
- NOT OK – Replace the sensor.

**Repair:** Refer to Testing And Adjusting, “Speed Sensor (Engine) - Adjust”.

STOP.

### **Test Step 6. CHECK THE HARNESS FOR AN OPEN OR A SHORT.**

- Press the **Stop** key on the EMCP 3 control.
- Disconnect the sensor from the engine harness. The sensor remains fastened to the engine.
- Disconnect the harness connector from the EMCP 3.
- Check for an open circuit. Check the resistance from contact “1” of the sensor harness connector to contact “66” of the EMCP 3 harness connector. The resistance should be 5 ohms or less.
- Check for an open circuit. Check the resistance from contact “2” of the sensor harness connector to contact “67” of the EMCP 3 harness connector. The resistance should be 5 ohms or less.
- Check for a short circuit. Check the resistance from contact “66” to contact “67” of the EMCP 3 harness connector. The resistance should be greater than 5000 ohms.

#### **Expected Result:**

When the resistance is measured between contact “1” of the sensor harness connector and contact “66” of the EMCP 3 harness connector, there should be 5 ohms or less.

The resistance from contact “2” of the sensor harness connector to contact “67” of the EMCP 3 harness connector should be 5 ohms or less.

The resistance from contact “66” to contact “67” of the EMCP 3 harness connector should be greater than 5000 ohms.

#### **Results:**

- OK – The harness functions properly. Proceed to Test Step 7.
- NOT OK – The circuit with the incorrect resistance measurement has failed. Replace the failed harness from the sensor to the EMCP 3 connector or repair the failed harness from the sensor to the EMCP 3 connector. STOP.

### **Test Step 7. CHECK THE SHIELD AND THE CONNECTORS.**

- Press the **Stop** key on the EMCP 3 control.
- Disconnect the sensor from the engine harness. The sensor remains fastened to the engine.
- Disconnect the harness connector from the EMCP 3.
- The harness has a shield (bare wire) which protects the sensor signal wire from electrical interference. This shield must be securely fastened and the shield must make a good electrical connection to ground.
- Check that the shield is securely fastened to ground.
- Check the connection between the sensor and the mating harness connector. Refer to Testing and Adjusting, “Electrical Connector - Inspect”.

#### **Expected Result:**

The shield should be securely fastened. The connection between the sensor and the mating harness connector should be secure.

#### **Results:**

- OK – The shield is securely fastened. The connection between the sensor and the mating harness connector is secure. Proceed to Test Step 8.
- NOT OK – One of the items is not correct. Repair the harness or replace the harness. STOP.

### Test Step 8. INSPECT THE SENSOR AND ADJUST THE SENSOR.

- A. Remove the sensor from the engine flywheel housing.
- B. Inspect the sensor for damage and remove any debris from the tip.

#### Expected Result:

No damage should be present.

#### Results:

- OK – No damage is present. Reinstall the engine speed sensor. Adjust the sensor.

**Repair:** For more information, refer to Testing And Adjusting, "Speed Sensor (Engine) - Adjust".

Proceed to Test Step 9.

- NOT OK – Damage is present. Replace the engine speed sensor.

**Repair:** Refer to Testing And Adjusting, "Speed Sensor (Engine) - Adjust".

STOP.

### Test Step 9. CHECK THE STATUS OF THE FAULT.

- A. Reconnect the harness connector to the EMCP 3 and the sensor.
- B. Press the **Stop** key on the EMCP 3 control.
- C. Check the EMCP 3 display for a sensor diagnostic code.

#### Expected Result:

A speed sensor diagnostic code should still be active.

#### Results:

- OK – A speed sensor diagnostic code is showing on the EMCP 3 display. The diagnostic code is still active and the engine will not start.

**Repair:** It is unlikely that the EMCP 3 has failed. Exit this procedure and perform this procedure again. If the diagnostic code is still present, replace the EMCP 3. Refer to Testing and Adjusting, "Electronic Control (Generator Set) - Replace".

STOP.

- NOT OK – A speed sensor diagnostic code is not showing on the upper display. These procedures have corrected the problem. The operator may continue with this procedure. Proceed to Test Step 10.

### Test Step 10. CHECK THE SIGNAL VOLTAGE.

- A. This is an additional check of the circuit. Make sure that all of the harness connectors are connected.
- B. Use a multimeter and 7x-1710 Multimeter Probes in order to measure the AC signal voltage. Measure the AC signal voltage between contact "66" and contact "67" of the EMCP 3 connector.
- C. Start the engine and run the engine at the rated speed.
- D. Measure the AC signal voltage of the engine speed sensor.

#### Expected Result:

The voltage should be equal to 2 VAC or greater.

#### Results:

- OK – The voltage is equal to 2 VAC or greater. The speed sensor circuit is correct. STOP.
- NOT OK – The voltage is not equal to 2 VAC or greater. The most likely cause is improper air gap of the pickup.

**Repair:** For more information, refer to Testing And Adjusting, "Speed Sensor (Engine) - Adjust".

STOP.

i02464587

## Unexpected Engine Shutdown

**SMCS Code:** 4490

#### System Operation Description:

While the engine is running, if engine speed suddenly becomes zero and the Auto Start/Stop function block has not initiated a shutdown, an "UNEXPECTED ENGINE SHUTDOWN" event will be activated.

The EMCP 3 performs the following using an independent engine speed sensor that is dedicated to EMCP 3 use only

- Determines the engine speed, in rpm, from the Magnetic Pickup (Engine Speed Sensor) input pins

- Detects diagnostics on the sensor
- Annunciates an engine over/under speed condition

**Conditions Which Generate This Code:**

While the engine is running, if engine speed suddenly becomes zero and the Auto Start/Stop function block has not initiated a shutdown, an "UNEXPECTED ENGINE SHUTDOWN" event will be activated.

**Test Step 1. TALK TO THE OPERATOR**

- A.** Determine the conditions that caused the unexpected shutdown.

**Expected Result:**

A unexpected shutdown was caused by an occurrence known to the operator and the operator would like to put the genset back into service.

**Results:**

- OK – The operator can determine the cause for the "UNEXPECTED ENGINE SHUTDOWN", the condition has been repaired and the operator wants to put the genset back into service.

**Repair:** Reset the genset. Resume normal operation and verify that the problem has been corrected.

STOP.

- NOT OK – The "UNEXPECTED ENGINE SHUTDOWN" was not caused by a occurrence known to the operator. Proceed to Test Step 2

**Test Step 2. CHECK FOR OTHER DIAGNOSTIC CODES.**

- A.** Check for active diagnostic codes on the engine ECM and the EMCP 3. If any codes are present, correct the diagnostic codes first.

**Expected Result:**

No other diagnostic codes or indicators are active.

**Results:**

- OK – No other diagnostic codes or indicators are active.

**Repair:** Refer to the engine Troubleshooting manual for more information on engine unexpected engine shutdowns for your particular genset.

STOP.

- NOT OK – Another diagnostic code is active or an indicator is active.

**Repair:** Exit this procedure. Troubleshoot the active code or indicator. Resume normal operation and verify that the problem has been corrected.

STOP.

# Testing and Adjusting Section

## Testing and Adjusting

i02464725

### Electrical Connector - Inspect

**SMCS Code:** 7553-040

Intermittent electrical problems are often caused by poor connections. Use the following checks as a reference for inspecting connectors.

#### 1. Check the connection of the connectors.

- Ensure that the locking rings are properly locked.
- Ensure that locking clips are used on Sure Seal connectors.
- Ensure that the center of the connector is tight.
- Ensure that the connector pins and sockets align properly.

#### 2. Check the wires at the connector.

- Ensure that the wires are straight as they enter the back of the connector.
- Ensure that each wire is properly crimped into the proper connector contact.
- Ensure that each connector contact is properly locked into the connector contact. When the connector contact is locked properly, the contact (wire) cannot be pulled out of the connector body without excessive force.

#### 3. Check each wire for nicks or signs of abrasion in the insulation.

#### 4. Check for moisture at the connector.

- Check for damaged connector seals or lost connector seals.
- Check for missing or loose wire hole plugs.
- Check for wires that do not enter the connector properly.

- If the wires enter the connector at an angle, there may not be a good seal between the connector and the wire insulation.
- Moisture can enter the connector through the wire insulation.

#### 5. Check for dirty contacts or corroded contacts.

- Clean contacts with a cotton swab or a soft brush and denatured alcohol ONLY.

#### 6. Check each pin and each socket.

- Check each contact of the connector for a snug fit by using a new pin and socket. The new contact should stay connected if the connector is held with the contacts that are facing down.

i02464706

### Wiring Harness (Open Circuit) - Test

**SMCS Code:** 1408-081

An open is a failure of an electrical circuit that results in no flow of electrical current. An open circuit is usually caused by failed electrical wires or a poor connection of electrical connectors. If an electrical wire or a connection is broken, then the flow of electrical current through the circuit is interrupted. A normally closed circuit will have less than 5 ohms of resistance. The following procedure explains the test for an open circuit:

**Reference:** For a complete electrical schematic, refer to Electrical System Schematic for the genset that is being serviced.

#### TEST FOR AN OPEN CIRCUIT.

1. Identify the connectors and the wire numbers of the suspect circuits. Use the Electrical System Schematic of the genset to identify the circuits.
2. Turn the disconnect switch to the OFF position.
3. Disconnect the components and the ECM from the wiring harness.
4. At one of the disconnected harness connections, place a jumper wire from the contact of the suspect wire to frame ground.
5. At the other connector of the genset harness, use the multimeter probes to measure the resistance from the contact of the suspect wire to frame ground.

**Expected Result:** The resistance is less than 5 ohms.

**OK** – The resistance is less than 5 ohms. The harness circuit is correct.

**Stop.**

**NOT OK** – The resistance is greater than 5000 ohms. There is an open in the genset harness.

**Repair:** Repair the genset harness or replace the genset harness.

**Stop.**

**OK** – The resistance is greater than 5000 ohms for all the measurements. The harness circuits are correct.

**Stop.**

**NOT OK** – The resistance is less than 5000 ohms. There is a short in the genset harness. The short is between the suspect wire and the wire with the lowest resistance measurement.

**Repair:** Repair the genset harness or replace the genset harness.

**Stop.**

i02464705

## Wiring Harness (Short Circuit) - Test

**SMCS Code:** 1408-081

A short circuit is a failure of an electrical circuit that results in undesired electrical current. Usually, a short circuit is a bypass of the circuit across a load. For example, a short across the wires in a circuit for a lamp produces too much current in the wires but no current is felt at the lamp. The lamp is shorted out. The resistance in a normal circuit can vary, but the resistance between a particular circuit and other unrelated circuits is always greater than 5000 ohms. The following procedure explains the test for a short circuit:

**Reference:** For a complete electrical schematic, refer to Electrical System Schematic for the genset that is being serviced.

### TEST FOR A SHORT CIRCUIT.

1. Identify the connectors and the wire numbers of the suspect circuits. Use the Electrical System Schematic of the genset to identify the circuits.
2. Turn the key start switch and the disconnect switch to the OFF position.
3. Disconnect the component and the ECM from the wiring harness.
4. At the genset harness connector for the ECM, place one of the multimeter probes on the contact of the suspect wire.
5. Use the other multimeter probe to check the resistance across all other contacts in the connector(s) of the ECM and frame ground.

**Expected Result:** The resistance is greater than 5000 ohms for all the measurements.

i02459150

## External Potential Transformer Connections

**SMCS Code:** 1409-077

In order to monitor generator output voltages greater than 600 Volts, potential transformers (PTs) must be used.

**Note:** The EMCP 3 must be programmed when connecting external PTs.

**Reference:** Systems Operation, "Setpoint Programming" and Testing and Adjusting, "Electronic Control Module (Generator Set) - Configure".

**Note:** The wye configuration of external PTs is preferred for 4-wire wye generators because of the greater accuracy when loads are unbalanced. With the open delta configuration, some power parameters cannot be determined. These parameters are real power phase A, B, C and power factor phase A, B, C. For maximum accuracy, the open delta configuration of external PTs should be used only for 3-wire delta generators.

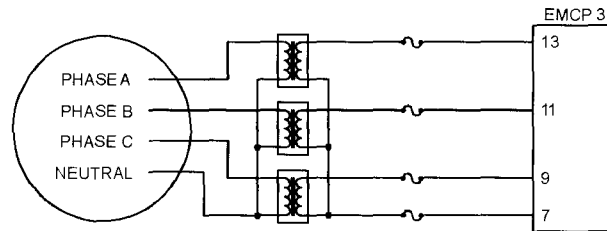

Illustration 19

g01228369

**Wye configuration of external potential transformers on the 4-wire Wye Generator**

This configuration allows the accurate measurement of all power parameters by the EMCP 3 including when the loads are unbalanced and neutral current is present. All power parameters are shown on the display of the EMCP 3. The EMCP 3 configuration parameter "Generator Connection Configuration" should be set to WYE (or STAR).

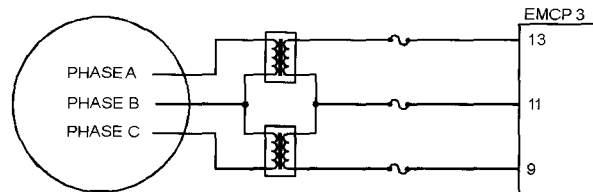

Illustration 20

g01228370

**Open Delta Configuration of external potential transformers on the 3-wire Delta Generator**

This configuration allows the accurate measurement of power parameters by the EMCP 3 including when the loads are unbalanced and circulating current is present. The real power phase A, B and C cannot be determined. The power factor phase A, B and C cannot be determined. The phases are not shown on the EMCP 3 display. The EMCP 3 configuration parameter "Generator Connection Configuration" should be set to DELTA (3-WIRE).

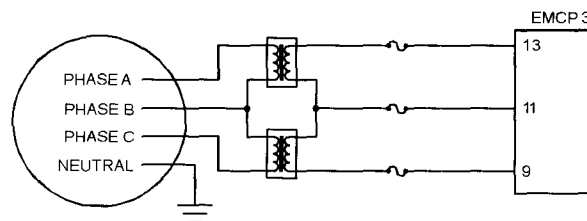

Illustration 21

g01228371

**Open Delta configuration of external potential transformers on the 4-wire Wye Generator**

This configuration results in less accurate measurement of all power parameters by the "EMCP 3" when the loads are unbalanced and neutral current is present. Real power phase A, B, C and power factor phase A, B, C cannot be determined and are not shown on the "EMCP 3" display. The EMCP 3 configuration parameter "Generator Connection Configuration" should be set to DELTA (3-WIRE).

On 4-wire wye generators, three separate PTs are required for accurate power metering unless the loads are completely and continually balanced. Even if the loads are balanced, some power parameters cannot be determined. Real power phase A, B, C and power factor phase A, B, C are not shown on the EMCP 3 display.

On 3-wire delta generators, two PTs allow maximum accuracy for all load conditions. Real power phase A, B, C and power factor phase A, B, C cannot be determined and are not shown on the EMCP 3 display.

i02489821

## Engine Speed Timing Calibration - Setup

**SMCS Code:** 1912-587

The following procedure describes the adjustments that are required if an "Engine Speed Timing Calibration" is performed. After this procedure has been completed, the engine can be started and the engine can be run at rated speed.

**Note:** This procedure does not include the instructions for performing the actual calibration.

**Note:** Before changing any value per this procedure, record the original value.

1. Stop the engine.
2. Set the "Engine Start Fault Protection Activation Delay Time" setpoint in the EMCP 3 to 90 seconds.
3. If a device such as a load share module is supplying the PWM signal in order to bias the engine speed, then disconnect the wires from the device. Go to Step 5

If there is not a device that is supplying the PWM signal and the engine speed bias is controlled from the EMCP 3, then go to Step 4.

4. Use the Caterpillar Electronic Technician (Cat ET) in order to set the "Desired Speed Input Configuration" setpoint in the engine ECM to "PWM".
5. Use the Caterpillar Electronic Technician (Cat ET) in order to set the "Secondary Desired Speed Input Configuration" setpoint in the Engine ECM to "DISABLED".
6. Start the engine and run the engine at idle speed.
7. Perform the "Engine Speed Timing Calibration" .
8. Stop the engine.

9. Use Cat ET in order to return the setpoints that were modified in Step 2 through Step 5 to the original values.
10. Reconnect any wires that were disconnected in Step 3.

i02464712

## Speed Sensor (Engine) - Adjust

**SMCS Code:** 1907-025

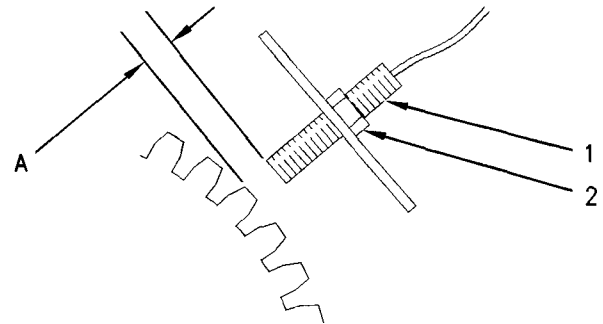

Illustration 22

g00289497

Speed Sensor

- (1) Speed sensor  
(2) Locknut  
(A) Air gap

**Note:** The engine speed sensor is commonly referred as a magnetic pickup sensor.

This adjustment procedure is for the engine speed sensor.

1. Remove the speed sensor (1) from the flywheel housing. Remove all debris from the tip of the speed sensor. Align a ring gear tooth directly in the center of the threaded sensor opening.
2. By hand, screw the speed sensor (1) into the hole until the end of the sensor contacts the gear tooth.
3. Turn the sensor (1) in the counterclockwise direction through 270 degrees (three-fourths turn).
4. Tighten locknut (2) to  $25 \pm 5$  N·m ( $18 \pm 4$  lb ft).

**Note:** Do not allow speed sensor (1) to turn as locknut (2) is tightened.

i02459627

## Engine Setpoint Verification - Test

**SMCS Code:** 4490-081

The Engine setpoint verification procedure verifies that the EMCP 3 operates correctly when one of the following faults occurs:

**Engine overspeed** – Causes the EMCP 3 to shut the engine down

**High coolant temperature** – Causes the EMCP 3 to either shut the engine down or to issue a warning based on the event response configuration setpoints

**Low oil pressure** – Causes the EMCP 3 to either shut the engine down or to issue a warning based on the event response configuration setpoints

### Relevant Engine Parameter Group Setpoints

The engine setpoint verification procedure is used in order to adjust the relevant configuration setpoints in the configuration parameter groups that are used during normal operation.

The following conditions are required before the engine setpoints are verified:

- The relevant setpoints listed in each configuration parameter group must be correct for the engine application
- No shutdown events should be present at the initial start up. If necessary, troubleshoot, correct, and reset any and all shutdown events.

During the procedure, each configuration setpoint that is to be adjusted should be recorded, and then returned to the original setting after the setpoint has been verified.

**Note:** Prior to performing this procedure, a service replacement file can be saved using the Caterpillar service tool. The replacement file is used in order to record the configuration to allow reprogramming the control with the original setpoints after the procedure has been completed.

### Engine Protection Events Configuration

- High Engine Coolant Temperature Shutdown Event Response Configuration (Hard Shutdown Enable/Disable)

- Low Engine Oil Pressure Shutdown Event Response Configuration (Hard Shutdown Enable/Disable)

### Engine Speed Monitor

Table 34

Engine Over Speed Shutdown Threshold (adjust value)	
Adjustment Range	400 to 4330 RPM in 1 RPM increments
Default value	2120 RPM (or 1.18 times the rated speed)

### Engine Coolant Temperature Monitor

Table 35

High Engine Coolant Temperature Shutdown Event Threshold (adjust value) <sup>(1)</sup>	
Adjustment Range	49 °C (120 °F) to 120 °C (248 °F) in 1 degree increments
Default value	107 °C (225 °F)
Warning Indication	Occurs at 102 °C (216 °F)
Default Time Delay	10 seconds

<sup>(1)</sup> Requires engine to be running at rated speed for verification

### Engine Oil Pressure Monitor

Table 36

Low Engine Oil Pressure Shutdown Event Threshold (adjust value) <sup>(1)</sup>	
Adjustment Range	34 kPa (5 psi) to 690 kPa (100 psi) in one unit increments
Default value	205 kPa (30 psi)
Warning Indication	Occurs at 239 kPa (35 psi)
Default Time Delay	10 seconds

<sup>(1)</sup> Requires engine to be running at rated speed for verification

## Verification Procedures

### Overspeed

**Setpoint: Engine Over Speed Shutdown Threshold**

**Note:** This is a password protected Level 3 setpoint. The passwords only affect changing parameters from the EMCP 3 control panel display. Changing parameters with the Caterpillar Service Tool does not require passwords.

**Reference:** For details on changing the EMCP 3 security level, see Systems Operation, "Password Entry".

1. Start the engine and run the engine at its rated speed.
2. Adjust the setpoint value to a value that is below the speed that the engine is running, and then press the ENTER key. An Engine Overspeed Shutdown event will immediately occur.
3. View the event in the Genset Control event log.  
**Reference:** Systems Operation, "Event Viewing"
4. Reset the event.  
**Reference:** Systems Operation, "Event Resetting"
5. Return the setpoint value to its original value.

## Low Oil Pressure

### Setpoint: Low Engine Oil Pressure Shutdown Event Threshold

1. Start the engine and run the engine at its rated speed.
2. Adjust the setpoint value to a value that is above the oil pressure that is being displayed, and then press the ENTER key. A shutdown event will occur after the programmable time delay has expired. The default for this delay is ten seconds..
3. View the event in the Genset Control event log.  
**Reference:** Systems Operation, "Event Viewing"
4. Reset the event.  
**Reference:** Systems Operation, "Event Resetting"
5. Return the setpoint value to its original value.

## High Coolant Temperature

### Setpoint: High Engine Coolant Temperature Shutdown Event Threshold

1. Start the engine and run the engine at its rated speed.

2. Adjust setpoint value to a value that is below the engine coolant temperature that is being displayed, and then press the ENTER key. A shutdown event will occur after the programmable time delay has expired. The default for this delay is ten seconds.

3. View the event in the Genset Control event log.

**Reference:** Systems Operation, "Event Viewing"

4. Reset the event.

**Reference:** Systems Operation, "Event Resetting"

5. Return the setpoint value to its original value.

i02459197

## Electronic Control Module (Generator Set) - Replace

**SMCS Code:** 4490-510

### Replacement Procedure

**Note:** The configuration from the old ECM can be saved in the Caterpillar service tool. The configuration can then be uploaded to the new ECM.

1. The new ECM must be reprogrammed after installation. If the ECM that is being replaced is functional, then make a note of the following items: hour meter value, all engine setpoints, and any spare inputs or outputs that are programmed. See System OperationSystem Operation, "Setpoint Programming".
2. Shut down the engine. Remove the positive lead wire from the battery.
3. Remove the harness connector from the ECM. A 4 mm hex wrench is required in order to turn the fastening screw.
4. Remove the six nuts that fasten the ECM to the front panel. Remove the ECM.
5. Place the new ECM in the front panel and then install and tighten the six nuts that were previously removed in order to secure the new ECM to the front panel.
6. Reconnect the harness connector to the ECM and reconnect the positive lead wire to the battery.

**Reference:** Generator Set Wiring Diagram Testing And Adjusting, "Electronic Control Module Wiring Diagrams"

7. Using the values from the original ECM, reprogram the setpoints, the spare inputs/outputs, and the hour meter. Refer to Step 1.

i02463503

## Electronic Control Module (Generator Set) - Flash Program

**SMCS Code:** 4490-591

Perform the following procedure in order to flash program the Electronic Control Module (ECM) for the Generator Set. The ECM is flashed in order to upgrade the software. Flash programming of the ECM must also be done if the ECM has been replaced. The Caterpillar Electronic Technician contains the program WinFlash. WinFlash is used in order to load(flash) the software into the ECM. The following procedure is used in order to flash the software into the ECM.

### Procedure

1. Connect the Data Link Cable between the Communication Adapter and the Caterpillar Electronic Technician.
2. Connect the Data Link Cable between the Communication Adapter and the Service Connector of the genset.
3. Turn the disconnect switch to the ON position.
4. Use WinFlash in order to flash the software.

i02459214

## Electronic Control Module (Generator Set) - Configure

**SMCS Code:** 4490-025

### Function Keys and Navigation Keys

**Reference:** For a full explanation of the use of the Function keys (Enter, Escape) and the Navigation keys (Scroll Left, Scroll Right, Scroll Up, Scroll Down) that are referenced in this section, see Systems Operation, "Electronic Control Module (Generator Set)"

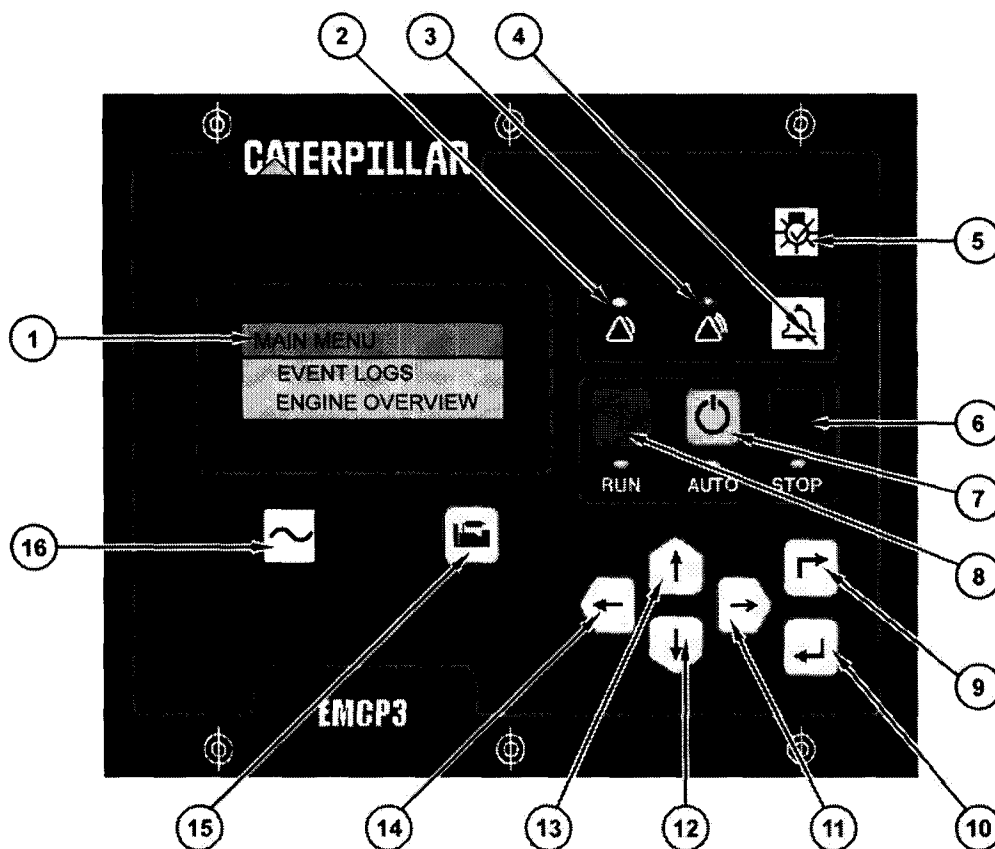

Illustration 23

g01211086

- |                                   |                       |                          |
|-----------------------------------|-----------------------|--------------------------|
| (1) Display Screen                | (7) Auto key          | (13) Scroll Up key       |
| (2) Yellow Warning Lamp           | (8) Run key           | (14) Scroll Left key     |
| (3) Red Shutdown Lamp             | (9) Escape key        | (15) Engine Overview key |
| (4) Alarm Acknowledge/Silence key | (10) Enter key        | (16) AC Overview key     |
| (5) Lamp Test key                 | (11) Scroll Right key |                          |
| (6) Stop key                      | (12) Scroll Down key  |                          |

**(9) Escape** – Navigate up (backward) through the menu structure and also used to cancel out of data entry screens during setpoint programming.

**(10) Enter** – Select a highlighted menu item

**(11) Scroll Right** – During numeric data entry, choose the digit to edit. During certain setpoint adjustments, select or deselect a checkbox.

**(12) Scroll Down** – Move down through the main menu or navigate within a list in order to highlight one of the items. Also used to decrement digits (0-9).

**(13) Scroll Up** – Move up through the main menu or navigate within a list in order to highlight one of the items. Also used to increment digits (0-9)

**(14) Scroll Left** – During numeric data entry, choose the digit to edit. During certain setpoint adjustments, select or deselect a checkbox.

## Initial Setup

Information from the EMCP 3 is displayed on the Display Screen (1). Press the **Scroll Up** key or the **Scroll Down** key in order to highlight the MAIN MENU options.

Press the **Enter** key in order to select one of the main menu options.

The keypad is also used in order to change the setpoints. Press the **Enter** key in order to change a setpoint. Press the **Scroll Up** key or the **Scroll Down** key in order to increase or decrease the value. Press the **Scroll Left** key or the **Scroll Right** key in order to change the digit that is to be adjusted.

**Note:** The EMCP 3 panel will power up to the MAIN MENU screen. If the EMCP 3 panel is already powered up, press the **Escape** key in order to return to the main menu. Each press of the Escape key moves you back one level in the menu structure,

## Setpoints

Within each setpoint category there are one or more function blocks. Each of those function blocks may contain one or more setpoints. Each of these setpoint categories and its corresponding function blocks are shown below.

### Control

- Automatic Start/Stop
- Automatic Voltage Regulator (AVR) Desired Voltage Request
- Generator Breaker Control
- Generator Desired Engine Speed Request
- Transfer Switch
- Utility Breaker Control

### Engine Monitor/Protect

- Battery Voltage Monitor
- Crank Attempt/Successful start Counter
- Engine Coolant Temperature Monitor
- Engine Oil Pressure Monitor
- Engine Speed Monitor
- Enhanced Engine Monitor
- Service Maintenance Interval

### Events

- Diagnostics Configuration
- Engine protection Events Configuration
- Generator Protection Events Configuration
- Other System Events Configuration
- Custom Events
- Event Output Function
- Event System

### Generator Monitor/Protect

- Enhanced Generator Monitor
- Generator AC Monitor
- Generator AC Power Monitor
- Generator Over Current
- Generator Over/Under Frequency
- Generator Over/Under Voltage
- Generator Reverse Power

### Discrete Input Output (I/O)

- Digital Inputs
- Digital Outputs
- Relay Outputs
- Spare Analog Input

### Network

- Data Link - SCADA

### Other

- Digital Selectors
- Reduced Power Mode

### Menu Maps

The maps in this section are to be used as a guide when programming the EMCP 3. Maps are provided for all versions of the controller.

## Programming the Display Preferences

The preferences affect the way data is viewed on the display screen. The configuration may need to be changed in order to meet local requirements.

In order to program the display preferences, perform the following menu options.

1. Press the **Escape** key as many times as necessary in order to go back to the MAIN MENU display.
  2. From the MAIN MENU, press the **Scroll Down** key or the **Scroll Up** key in order to highlight the PREFERENCES option. The following parameters can be changed
    - CONTRAST
    - BACKLIGHT
    - PRESSURE
    - TEMPERATURE
    - VOLUME
    - LANGUAGE
- a. Press the **Enter** key in order to select PREFERENCES. CONTRAST will be highlighted.
  - b. Press the **Enter** key in order to select the contrast level. The contrast can be adjusted between 1 and 100, with 1 being the least contrast and 100 being the greatest contrast. The display will show a status bar and a number representing the current contrast level.
  - c. Use the **Scroll Right** key or the **Scroll Left** key in order to adjust the contrast to the desired level, and then press the **Enter** key in order to save the new contrast setting.
  - d. Press the **Scroll Down** key in order to highlight BACKLIGHT and then press the **Enter** key in order to select the backlight function. The backlight can be adjusted between 1 and 100, with 1 being the least backlight and 100 being the greatest backlight. The display will show a status bar and a number representing the current backlight level.
  - e. Adjust the backlight to the desired level using the **Scroll Right** key or the **Scroll Left** key, and then press the **Enter** key in order to save the new backlight setting.
  - f. Press the **Scroll Down** key in order to highlight PRESSURE, and then press the **Enter** key in order to select the pressure function. The available options for pressure measurement are "kPa", "PSI", and "BAR". The display will list all three options, with the current option highlighted.
  - g. Adjust the pressure to the desired measurement unit using the **Scroll Right** key or the **Scroll Left** key, and then press the **Enter** key in order to save the pressure measurement unit.
  - h. Press the **Scroll Down** key in order to highlight TEMPERATURE and then press the **Enter** key in order to select the temperature function. The available options for temperature measurement are "°C" or "°F". The display will list both options, with the current option highlighted.
  - i. Adjust the temperature to the desired measurement scale using the **Scroll Right** key or the **Scroll Left** key, and then press the **Enter** key in order to save the temperature measurement unit.
  - j. Press the **Scroll Down** key in order to highlight VOLUME and then press the **Enter** key in order to select the volume function. The available options for volume measurement are "LITERS", "US GAL", or "IMP GAL". The display will list all three options, with the current option highlighted.
  - k. Highlight the desired volume measurement unit using the **Scroll Right** key or the **Scroll Left** key, and then press the **Enter** key in order to save the volume measurement unit.
  - l. Press the **Scroll Down** key in order to highlight LANGUAGE and then press the **Enter** key in order to select the language function. Language does not display a value to the right. The display will show one or two options. TECHNICIAN ENGLISH will always be shown and, if another language is available on the flash file, that language will also be shown as an options.
  - m. Highlight the desired language that is to be used for display on the EMCP 3 using the **Scroll Right** key or the **Scroll Left** key, and then press the **Enter** key (10) in order to save the desired language selection
  - n. Press the **Escape** key as required in order to step back up to the MAIN MENU.

## Programming The Setpoints

The engine/generator setpoints affect the proper operation and serviceability of the engine, and the accuracy of information shown on the display screen. The EMCP 3 setpoints are programmed at the factory.

The setpoints may require changing when the EMCP 3 is moved from one engine to another engine. The setpoints may also require changing in order to satisfy the site requirements. The setpoints that are stored in the EMCP 3 must match the specified setpoints of the particular generator set.

See the Setpoint tables following these procedures for a complete list of all the setpoint blocks. All of the setpoints listed in the tables should be verified and reprogrammed if required.

The first setpoint block to program is the Automatic Start/Stop Block. The Automatic Start/Stop Block is part of the Control Category. In order to program the Automatic Start/Stop Setpoints, perform the following:

1. Press the **Escape** key as required in order to step back to the MAIN MENU.
2. From the MAIN MENU, press the **Scroll Down** key until CONFIGURE is highlighted and then press the **Enter** key in order to select the menu.
3. Press the **Scroll Down** key until SETPOINTS is highlighted, and then press the **Enter** key in order to select the menu.
4. Press the **Scroll Down** key in order to scroll through the setpoint options until CONTROL is highlighted, and then press the **Enter** key in order to select the menu. The AUTOMATIC START / STOP menu is highlighted.
5. Press the **Enter** Key in order to select the AUTOMATIC START / STOP menu and then use the **Scroll Down** key and the **Scroll Up** key in order to highlight the next setpoint that is to be programmed.
6. Press the **Enter** key in order to select the setpoint and then press the **Enter** key a second time in order to highlight the current configuration of the selected setpoint.
7. Use the **Scroll Down** key and the **Scroll Up** key in order to change the current configuration to the desired setting, and then use the **Enter** key in order to save the new setting.
8. Repeat steps 5 through 7 in order to program all of the Automatic Start/Stop setpoints.
9. After all of the Automatic Start/Stop Setpoints are programmed as required, then press the **Escape** key in order to back up to the CONTROL menu.
10. The next block of setpoints that is to be programmed is the Automatic Voltage Regulator (AVR) Request block. Press the **Scroll Down** key in order to scroll through the setpoint options until AVR DESIRED VOLTAGE is highlighted, and then press the **Enter** key in order to select the menu.
11. Repeat steps 5 through 7 in order to program all of the AVR Request setpoints.
12. Continue programming the remaining function blocks in the "CONTROL" menu.
13. Press the **Escape** key twice in order to back up to the SETPOINTS menu.
14. Press the **Scroll Down** key in order to scroll through the setpoint options until ENGINE MONITOR/PROTECT is highlighted.
15. Press the **Enter** key in order to select the ENGINE MONITOR/PROTECT menu and then program all of the function blocks in this menu.
16. Continue to program the remaining setpoints until each setpoint in every setpoint category has been checked and programmed as required.

## SETPOINT TABLES

All of the available setpoints on the EMCP 3 are listed in the following tables. Refer to these tables while programming the setpoints.

### CONTROL

#### Automatic Start/Stop

The Automatic Start/Stop block receives starting and stopping requests from various sources (local, remote, internal), arbitrates between them and then cranks or shuts down the engine in an orderly fashion.

Table 37

Setpoints - Automatic Start/Stop <sup>(1)</sup>					
Setpoint Name	Min Value	Max Value	Units	Factory Default	Description
Engine start fault protection activation delay time	0	300	sec	30	Fault protection time delay prevents shut down during start up from low oil pressure etc.
Crank Duration	5	300	sec	10	Amount of time the EMCP 3 energizes (cranks) the starting motor
Crank Cycle Rest Interval	5	300	sec	10	Amount of time the EMCP 3 deenergizes the starting motor between crank cycles
Engine Purge Cycle Time	0	20	sec	0	
Maximum Number of Crank Cycles	1	20	n/a	5	Number of crank/rest cycles that the EMCP 3 uses to declare that a overcrank fault exists
Cooldown Duration	0	30	min.	5	Amount of time the EMCP 3 allows the engine to run after a normal shutdown is initiated
Start Aid Activation Time	0	240	sec.	0	Amount of time the EMCP 3 activates start aid control output. Set to 10 seconds if the EUI with prelube option is installed.
Crank Alert Activation Time	0	60	sec.	0	Amount of time the EMCP activates crank alert output.
Crank Terminate RPM	100	1000	rpm	400	Engine speed setting used in order to disengage the starting motor during engine cranking
Engine Fuel Type Configuration	n/a	n/a	n/a	Diesel	Setpoint allows for selection of "Diesel" or "Natural Gas"
Fuel Shutoff Solenoid Type Configuration	n/a	n/a	n/a	Energized to Run	Type of fuel system solenoid used on the generator set. Select "Energized to run" (ETR) or "Energized to Shut Off" (ETS).
Engine Type Configuration	n/a	n/a	n/a	Mechanical	Select mechanical or electronic
Engine Controller J1939 Data Link Support Configuration	n/a	n/a	n/a	No Data Link	Setpoint allows for selection of "No Data Link", "Basic Data Link", or "Enhanced Data" Link.
Engine Cool Down Speed Configuration	n/a	n/a	n/a	Rated	Setpoint allows for selection of engine speed during cooldown. Select rated or idle.
Engine Operating State Input Configuration	n/a	n/a	n/a	CAN Input	Setpoint configures whether the EMCP3 determines its operating state on its own, or whether it receives it over the data link from the engine ECM. Set to "CAN Input" for common engine interface engines and set to "Hard Wired" for non-common engine interface EUI engines and non-EUI engines.

<sup>(1)</sup> The setpoints that are stored or the setpoints that are being programmed must match the specified setpoints of the particular generator set.

### AVR Desired Voltage Request

The AVR Desired Voltage Request block generates a data link request over the J1939 data link in order to request a desired output voltage from the CDVR.

Table 38

Setpoints - AVR Desired Voltage Request <sup>(2)</sup>					
Setpoint Name	Min Value	Max Value	Units	Factory Default	Description
Maximum Generator Voltage Output Bias Percentage	0	100	%	15	The Maximum Generator Output voltage Bias Percent is the maximum value above and below the Nominal Voltage that the EMCP 3 will send a request for when adjusting the voltage from the control screen
Generator Nominal Output Voltage	100	50000	V	100	The Generator Nominal Output Voltage is the desired output voltage of the generator set. This value is set to match the generator rated voltage.

<sup>(2)</sup> The setpoints that are stored or the setpoints that are being programmed must match the specified setpoints of the particular generator set.

**Maximum Generator Output Voltage Bias Percent**

The following settings will only apply if there is a CDVR installed on the generator.

**Note:** It is possible to set the "MAXIMUM GEN OUTPUT VOLTAGE BIAS PERCENT" from 0 to 100% but the CDVR will only allow the voltage to change by a maximum of 15%.

1. From the MAIN MENU, press the **Scroll Down** key or the **Scroll Up** key in order to highlight the CONFIGURE menu, and then press the **Enter** key in order to select the menu. "SECURITY" will be highlighted.
2. Press the **Scroll Down** key in order to highlight the SETPOINTS menu, and then press the **Enter** key in order to select the menu. AUTOMATIC START/STOP will be highlighted.
3. Press the **Scroll Down** key in order to highlight the AVR DESIRED VOLTAGE menu, and then press the **Enter** key in order to select the menu. MAXIMUM GEN OUTPUT VOLTAGE BIAS PERCENT will be displayed.
4. Press the **Enter** key in order to select the AVR DESIRED VOLTAGE menu and then press the **Enter** key a second time in order to select the MAXIMUM GEN OUTPUT VOLTAGE BIAS PERCENT function and in order to display the current voltage bias percent.

**Note:** The voltage bias percent setpoint will determine the amount of voltage change for each key press on the voltage control screen. A higher value will result in a larger change in voltage per key press. A lower value will result in a smaller change in voltage per key press.

5. Press the **Scroll Down** key or the **Scroll Up** key in order to decrement or increment the highlighted digit to the desired value and then press the **Scroll Right** key or the **Scroll Left** key in order to highlight the next character that is to be entered.

6. Continue this process until the desired current voltage bias percent has been entered and then press the **Enter** key in order to save the new value.

**Generator Breaker Control**

The Generator Breaker Control block opens and to closes the generator breaker and generates alarms if the generator breaker fails to open or to close.

**Note:** Standard Caterpillar product does not utilize this group of setpoints.

Table 39

Setpoints - Generator Breaker Control <sup>(22)</sup>					
Setpoint Name	Min Value	Max Value	Units	Factory Default	Description
Generator Breaker Closing Pulse Active Time	0.1	10	sec.	1.0	
Generator Breaker Closing Pulse Rest Interval	0	60	sec.	15	
Generator Breaker Maximum Closing Time	1	120	sec.	60	
Generator Breaker Maximum Opening Time	1	20	sec.	3	
Generator Breaker Lockout Status	N/A	N/A	N/A	Not Locked Out	Select "Locked Out" or "Not Locked Out"
Generator Breaker Type Configuration	N/A	N/A	N/A	Manual	Select "Manual" or "Automatic"
Automatic Generator Breaker Control Source Configuration	N/A	N/A	N/A	Genset Controlled	Select "Genset Controlled" or "Externally Controlled"

<sup>(22)</sup> The setpoints that are stored or the setpoints that are being programmed must match the specified setpoints of the particular generator set.

### Generator Desired Engine Speed Request

The Generator Desired Engine Speed Request block generates a data link request over the J1939 data link in order to request a desired generator frequency from a generator.

Table 40

Setpoints - Generator Desired Engine Speed Request <sup>(27)</sup>					
Setpoint Name	Min Value	Max Value	Units	Factory Default	Description
Maximum Engine Speed Range	0	2000	rpm	100	The Maximum Engine Speed Range is the maximum value above and below the Nominal Engine Speed that the EMCP 3 will send a request for when adjusting the speed from the control screen
Generator Nominal Output Frequency	40	500	Hz	50	This value is set to match the generator rated frequency

<sup>(27)</sup> The setpoints that are stored or the setpoints that are being programmed must match the specified setpoints of the particular generator set.

### Transfer Switch

The Transfer Switch block enables automatic transition from utility power to standby genset power in the case of a Loss of Utility event or an internal request, and then automatically transitions back to utility power after the utility returns or the external request is removed.

**Note:** Standard Caterpillar product does not utilize this group of setpoints.

Table 41

Setpoints - Transfer Switch <sup>(33)</sup>					
Setpoint Name	Min Value	Max Value	Units	Factory Default	Description
Generator/Utility Automatic Transfer Enable Status	N/A	N/A	N/A	Disabled	
Loss of Utility Event Notification Delay Time	0	30	sec.	10	
Utility to Generator Transfer Delay Time	1	60	sec.	3	
Generator to Utility Transfer Delay Time	1	60	min.	180	
Generator to Utility Fast Transfer Delay Time	1	60	sec.	10	
Utility to Generator Transfer Failure Warning Event Threshold	1	240	sec.	60	
Utility to Generator Transfer Failure Shutdown Event Threshold	1	240	sec.	90	
Generator to Utility Transfer Failure Warning Event Threshold	1	240	sec.	60	

<sup>(33)</sup> The setpoints that are stored or the setpoints that are being programmed must match the specified setpoints of the particular generator set.

### Utility Breaker Control

The Utility Breaker Control block opens and closes the utility breaker and generates alarms when the utility breaker fails to open or to close.

**Note:** Standard Caterpillar product does not utilize this group of setpoints.

Table 42

Setpoints - Utility Breaker Control <sup>(34)</sup>					
Setpoint Name	Min Value	Max Value	Units	Factory Default	Description
Utility Breaker Closing Pulse Active Time	0.1	10.0	sec.	1.0	
Utility Breaker Closing Pulse Rest Interval	0	60	sec.	15	
Utility Breaker Maximum Closing Time	1	120	sec.	60	
Utility Breaker Maximum Opening Time	1	20	sec.	3	
Utility Breaker Lockout Status	N/A	N/A	N/A	Not Locked Out	Select "Locked Out" or "Not Locked Out"
Utility Breaker Type Configuration Automatic	N/A	N/A	N/A	Manual	Select "Manual" or "Automatic"
Utility Breaker Control Source Configuration	N/A	N/A	N/A	Genset controlled	Select "Genset Controlled" or "Externally Controlled"

<sup>(34)</sup> The setpoints that are stored or the setpoints that are being programmed must match the specified setpoints of the particular generator set.

## ENGINE MONITOR / PROTECT

### Battery Voltage Monitor

The Battery Voltage Monitor block measures the battery supply voltage to the EMCP 3. The EMCP 3 will have the ability to monitor the battery supply voltage based on the "+BATT" and "-BATT".

Table 43

Setpoints - Battery Voltage Monitor <sup>(3)</sup>					
Setpoint Name	Min Value	Max Value	Units	Factory Default	Description
High Battery Voltage Warning Event Threshold	12	50	VDC	29.4	
High Battery Voltage Warning Event Notification Delay Time	0	240	sec	30	
High Battery Voltage Shutdown Event Threshold	12	50	VDC	32.0	
High Battery Voltage Shutdown Event Notification Delay Time	0	240	sec	2	
Low Battery Voltage Warning Event Threshold	0.0	25.0	VDC	18.0	
Low Battery Voltage Warning Event Notification Delay Time	0	240	sec	10	
Low Battery Charging System Voltage Warning Event Threshold	0	30	VDC	26	
Low Battery Charging System Voltage Warning Event Notification Delay Time	0	240	sec	30	

<sup>(3)</sup> The setpoints that are stored or the setpoints that are being programmed must match the specified setpoints of the particular generator set.

### Crank Attempt/Successful Start Counter

The Crank Attempt/Successful Start Counter block tracks the number of times the engine has been cranked and the number of times the engine has been successfully started.

Table 44

Setpoints - Crank Attempt / Successful Start Counter <sup>(31)</sup>					
Setpoint Name	Min Value	Max Value	Units	Factory Default	Description
Customer Security Password Level to Reset Crank/Start Counters	0	4	n/a	3	Password level required in order to reset the Crank/Start Counters

<sup>(31)</sup> The setpoints that are stored or the setpoints that are being programmed must match the specified setpoints of the particular generator set.

### Engine Coolant Temperature Monitor

The Engine Coolant Temperature Monitor block converts a raw sensor value into coolant temperature and, when configured as a sensor, detects sensor diagnostics.

Table 45

<b>Setpoints - Engine Coolant Temperature Monitor<sup>(10)</sup></b>					
<b>Setpoint Name</b>	<b>Min Value</b>	<b>Max Value</b>	<b>Units</b>	<b>Factory Default</b>	<b>Description</b>
Engine Coolant Temperature Sensor Configuration	N/A	N/A	N/A	Sensor	Select "Sensor" or "Data Link". Set to Sensor for MUI Engines or set to Data Link for EUI engines.
High Engine Coolant Temperature Warning Event Threshold	49 °C (120 °F)	120 °C (248 °F)	deg.	102 °C (216 °F)	
High Engine Coolant Temperature Warning Event Notification Delay Time	0	30	sec.	2	
High Engine Coolant Temperature Shutdown Event Threshold	49 °C (120 °F)	120 °C (248 °F)	deg.	107 °C (225 °F)	
High Engine Coolant Temperature Shutdown Event Notification Delay Time	0	30	sec.	10	
Low Engine Coolant Temperature Warning Event Threshold	0 °C ( 32°F)	36 °C (99 °F)		21 °C (70 °F)	
Low Engine Coolant Temperature Warning Event Notification Delay Time	0	30	sec.	2	

<sup>(10)</sup> The setpoints that are stored or the setpoints that are being programmed must match the specified setpoints of the particular generator set.

### Engine Oil Pressure Monitor

The Engine Oil Pressure Monitor block converts a raw sensor value into oil pressure and, when configured as a sensor, detects sensor diagnostics.

Table 46

Setpoints - Engine Oil Pressure Monitor <sup>(1)</sup>					
Setpoint Name	Min Value	Max Value	Units	Factory Default	Description
Engine Oil Pressure Sensor Configuration	N/A	N/A	N/A	Sensor	Select "Sensor" or "Data Link". Set to Sensor for MUI Engines or set to Data Link for EUI engines.
Low Engine Oil Pressure Warning Event Threshold	34 kPa (5 psi)	690 kPa (100 psi)	kPa	239 kPa (35 psi)	
Low Idle Low Engine Oil Pressure Warning Event Threshold	34 kPa (5 psi)	690 kPa (100 psi)	kPa	104 kPa (15 psi)	
Low Engine Oil Pressure Warning Event Notification Delay Time	0	30	sec.	0	
Low Engine Oil Pressure Shutdown Event Threshold	34 kPa (5 psi)	690 kPa (100 psi)	kPa	205 kPa (30 psi)	
Low Idle Low Engine Oil Pressure Shutdown Event Threshold	34 kPa (5 psi)	690 kPa (100 psi)	kPa	70 kPa (10 psi)	
Low Engine Oil Pressure Shutdown Event Notification Delay Time	0	30	sec.	10	
Low Engine Oil Pressure Step Speed	400	1800	RPM	1200	When the engine speed is below this setpoint, the Low Idle setpoint is used. Set to 800 RPM for engines rated at 1000 or 1200 RPM. Set to 1200 RPM for engines rated at 1500 or 1800 RPM.

<sup>(1)</sup> The setpoints that are stored or the setpoints that are being programmed must match the specified setpoints of the particular generator set.

### Engine Speed Monitor

The Engine Speed Monitor block determines the engine speed, in rpm, from the Magnetic Pickup (MPU) input pins and detects diagnostics on the MPU. The MPU used for these determinations will be an independent MPU to be used by the EMCP 3 only.

**Note:** All Engine Speed Monitor setpoints require a "LEVEL 3" password. Engine Speed Monitor setpoints may also be changed with Caterpillar Electronic Technician software without a password.

Table 47

Setpoints - Engine Speed Monitor <sup>(12)</sup>						
Setpoint Name	Min Value	Max Value	Units	Factory Default	Description	
Flywheel Teeth	95	350	N/A	183		
Engine Over Speed Shutdown Threshold	400	4330	rpm	2120	Set to 118% of rated speed	
Engine Under Speed Warning Event Threshold	400	4330	rpm	1550	Set to 86% of rated speed	
Engine Under Speed Warning Event Notification Delay Time	0.0	20.0	sec.	2.0		
Engine Under Speed Shutdown Event Threshold	400	4330	rpm	1480	Set to 82% of rated speed	
Engine Under Speed Shutdown Event Notification Delay Time	0.0	20.0	sec.	2.0		

<sup>(12)</sup> The setpoints that are stored or the setpoints that are being programmed must match the specified setpoints of the particular generator set.

### Enhanced Engine Monitor

The Enhanced Engine Monitor block provides a method to access the engine cylinder temperature parameters from the Primary Data Link for use in configuration logic.

**Note:** Standard Caterpillar product does not utilize this group of setpoints.

Table 48

Setpoints - Enhanced Engine Monitor <sup>(31)</sup>						
Setpoint Name	Min Value	Max Value	Units	Factory Default	Description	
Engine Cylinder Temperature Sensor Installation Status	0	1	n/a	Not Installed	Select "Installed" or "Not installed"	
Number of Engine Cylinders	1	20	n/a	1		

<sup>(31)</sup> The setpoints that are stored or the setpoints that are being programmed must match the specified setpoints of the particular generator set.

### Service Maintenance Interval

The Service Maintenance Interval block annunciates a need for engine service based on engine hours or duration since the last service, whichever occurs first.

Table 49

Setpoints - Service Maintenance Interval <sup>(31)</sup>						
Setpoint Name	Min Value	Max Value	Units	Factory Default	Description	
Service Maintenance Interval Hours	0	2000	hours	500 hours		
Service Maintenance Interval Days	0	365	days	180 days		

<sup>(31)</sup> The setpoints that are stored or the setpoints that are being programmed must match the specified setpoints of the particular generator set.

## EVENTS

Table 50

Description of Event Response Selections	
Active Only	Only displays event in the event log (no history on the event)
Warning	Event logged, amber warning status LED
Audible Alert	Activates relay output configured as "horn control"
Soft Shutdown	Shutdown event allows cooldown cycle
Hard Shutdown	Shutdown event skips cooldown cycle for fast engine shutdown
Breaker 1 Trip	Activates relay output configured as "breaker 1 trip"
Breaker 2 Trip	Activates relay output configured as "breaker 2 trip"
FTP	Suppress the event until the engine is running and the fault protection timer has expired

### Diagnostics Configuration

**WARNING**

**Warning and/or shutdown events should not be disabled. If warning or shutdown events are disabled, the user may not be aware of conditions that could cause damage to the engine, generator, or electrical loads. If warning or shutdown events are disabled, make sure that there is another control that is set up that can diagnose the event, and if necessary, will shut the engine down.**

The "Diagnostics Configuration" block is used in order to configure the desired response for any diagnostic that is generated by the genset control.

The Diagnostics Configuration block is subdivided into four subcategories as follows: Pressures, Temperatures, Levels, and Others. Each of the Diagnostics Configuration subcategories is shown in its own table.

**Note:** Table 51 lists the available options for each setpoint in the "PRESSURES" category. The options that are available for each setpoint are designated by an "X" in the option column.

Table 51

"PRESSURE" Setpoints - Diagnostics Configuration <sup>(15)</sup>									
Setpoint Name	Warning	Audible Alert	Soft Shutdown	Hard Shutdown	Loss of Utility	Breaker Trip #1	Breaker Trip #2	FPT	Active Only
Air Filter Differential Pressure Sensor Diagnostic Response Configuration	X	X	X	X		X	X		
Engine Oil Pressure Sensor Diagnostic Response Configuration	X	X	X	X		X	X		
Fire Extinguisher Pressure Sensor Diagnostic Response Configuration	X	X	X	X		X	X		
Fuel Filter Differential Pressure Sensor Diagnostic Response Configuration	X	X	X	X		X	X		
Engine Oil Filter Differential Pressure Sensor Diagnostic Response Configuration	X	X	X	X		X	X		
Starting Air Pressure Sensor Diagnostic Response Configuration	X	X	X	X		X	X		

<sup>(15)</sup> Each setpoint in the Diagnostics Configuration block is used in order to program a system response to the associated Suspect Parameter Number/Failure Mode Identifier (SPN/FMI) for any internal source.

**Note:** Table 52 lists the available options for each setpoint in the "TEMPERATURE" category. The options that are available for each setpoint are designated by an "X" in the option column.

Table 52

"TEMPERATURE" Setpoints - Diagnostics Configuration <sup>(15)</sup>									
Setpoint Name	Warning	Audible Alert	Soft Shutdown	Hard Shutdown	Loss of Utility	Breaker Trip #1	Breaker Trip #2	FPT	Active Only
Ambient Air Temperature Sensor Diagnostic Response Configuration	X	X	X	X		X	X		
Engine Coolant Temperature Sensor Diagnostic Response Configuration	X	X	X	X		X	X		
Engine Oil Temperature Sensor Diagnostic Response Configuration	X	X	X	X		X	X		
Exhaust Temperature Sensor Diagnostic Response Configuration	X	X	X	X		X	X		
Right Exhaust Temperature Sensor Diagnostic Response Configuration	X	X	X	X		X	X		
Left Exhaust Temperature Sensor Diagnostic Response Configuration	X	X	X	X		X	X		
Generator Bearing #1 Temperature Sensor Diagnostic Response Configuration	X	X	X	X		X	X		

<sup>(15)</sup> Each setpoint in the Diagnostics Configuration block is used in order to program a system response to the associated Suspect Parameter Number/Failure Mode Identifier (SPN/FMI) for any internal source.

**Note:** Table 53 lists the available options for each setpoint in the "LEVEL" category. The options that are available for each setpoint are designated by an "X" in the option column.

Table 53

"LEVEL" Setpoints - Diagnostics Configuration <sup>(15)</sup>									
Setpoint Name	Warning	Audible Alert	Soft Shutdown	Hard Shutdown	Loss of Utility	Breaker Trip #1	Breaker Trip #2	FPT	Active Only
Engine Coolant Level Sensor Diagnostic Response Configuration	X	X	X	X		X	X		
Engine Oil Level Sensor Diagnostic Response Configuration	X	X	X	X		X	X		
Fuel Level Sensor Diagnostic Response Configuration	X	X	X	X		X	X		
External Tank Fuel Level Sensor Diagnostic Response Configuration	X	X	X	X		X	X		

<sup>(15)</sup> Each setpoint in the Diagnostics Configuration block is used in order to program a system response to the associated Suspect Parameter Number/Failure Mode Identifier (SPN/FMI) for any internal source.

**Note:** Table 54 lists the available options for each setpoint in the "OTHER" setpoints category. The options that are available for each setpoint are designated by an "X" in the option column.

Table 54

"OTHER" Setpoints - Diagnostics Configuration <sup>(15)</sup>									
Setpoint Name	Warning	Audible Alert	Soft Shutdown	Hard Shutdown	Loss of Utility	Breaker Trip #1	Breaker Trip #2	FPT	Active Only
Accessory Data Link Diagnostic Response Configuration	X	X	X	X		X	X		
Digital Output #1 Diagnostic Response Configuration	X	X	X	X		X	X		
Digital Output #2 Diagnostic Response Configuration	X	X	X	X		X	X		
Engine Speed Sensor Diagnostic Response Configuration		X		X <sup>(16)</sup>		X	X		
Generator Output Sensing System Diagnostic Response Configuration	X	X	X	X		X	X		
Primary Data Link Diagnostic Response Configuration	X	X	X	X		X	X		
SCADA Data Link Diagnostic Response Configuration	X	X	X	X		X	X	X	

<sup>(15)</sup> Each setpoint in the Diagnostics Configuration block is used in order to program a system response to the associated Suspect Parameter Number/Failure Mode Identifier (SPN/FMI) for any internal source.

<sup>(16)</sup> Setpoint Is not adjustable

### Engine Protection Events Configuration



**Warning and/or shutdown events should not be disabled. If warning or shutdown events are disabled, the user may not be aware of conditions that could cause damage to the engine, generator, or electrical loads. If warning or shutdown events are disabled, make sure that there is another control that is set up that can diagnose the event, and if necessary, will shut the engine down.**

The Engine Protection Events Configuration block is used in order to configure the desired response for any engine protection event generated by the genset control.

The Engine Protection events Configuration block is subdivided into 4 categories as follows: Pressures, Temperatures, Levels, and Others. Each of the Diagnostics Configuration subcategories is shown in it's own table.

**Note:** Table 55 lists the available options for each "PRESSURE" setpoint. The options that are available for each setpoint are designated by an "X" in the option column.

Table 55

<b>"PRESSURE" Setpoints - Engine Protection Events Configuration<sup>(17)</sup></b>									
<b>Setpoint Name</b>	<b>Warning</b>	<b>Audible Alert</b>	<b>Soft Shutdown</b>	<b>Hard Shutdown</b>	<b>Loss of Utility</b>	<b>Breaker Trip #1</b>	<b>Breaker Trip #2</b>	<b>FPT</b>	<b>Active Only</b>
High Air Filter Differential Pressure Warning Event Response Configuration	X	X				X	X		
High Air Filter Differential Pressure Shutdown Event Response Configuration		X	X	X		X	X		
Low Air Filter Differential Pressure Warning Event Response Configuration	X	X				X	X	X	
Low Air Filter Differential Pressure Shutdown Event Response Configuration		X	X	X		X	X	X	
High Gas Pressure Warning Event Response Configuration	X	X				X	X		
High Gas Pressure Shutdown Event Response Configuration		X	X	X		X	X		
Low Gas Pressure Warning Event Response Configuration	X	X				X	X		
Low Gas Pressure Shutdown Event Response Configuration		X	X	X		X	X		

(continued)

(Table 55, contd)

<b>"PRESSURE" Setpoints - Engine Protection Events Configuration<sup>(17)</sup></b>									
<b>Setpoint Name</b>	<b>Warning</b>	<b>Audible Alert</b>	<b>Soft Shutdown</b>	<b>Hard Shutdown</b>	<b>Loss of Utility</b>	<b>Breaker Trip #1</b>	<b>Breaker Trip #2</b>	<b>FPT</b>	<b>Active Only</b>
Low Engine Oil Pressure Warning Event Response Configuration	X	X				X	X	X	
Low Engine Oil Pressure Shutdown Event Response Configuration		X	X	X		X	X	X	
High Fuel Filter Differential Pressure Warning Event Response Configuration	x	x				x	X		
High Fuel Filter Differential Pressure Shutdown Event Response Configuration		X	X	X		X	X		
Low Fuel Filter Differential Pressure Warning Event Response Configuration	X	X				X	X	X	
Low Fuel Filter Differential Pressure Shutdown Event Response Configuration		X	X	X		X	X	X	
High Engine Oil Filter Differential Pressure Warning Event Response Configuration	X	X				X	X		
High Engine Oil Filter Differential Pressure Shutdown Event Response Configuration		X	X	X		X	X		

(continued)

(Table 55, contd)

<b>"PRESSURE" Setpoints - Engine Protection Events Configuration<sup>(17)</sup></b>									
<b>Setpoint Name</b>	<b>Warning</b>	<b>Audible Alert</b>	<b>Soft Shutdown</b>	<b>Hard Shutdown</b>	<b>Loss of Utility</b>	<b>Breaker Trip #1</b>	<b>Breaker Trip #2</b>	<b>FPT</b>	<b>Active Only</b>
Low Engine Oil Filter Differential Pressure Warning Event Response Configuration	X	X				X	X	X	
Low Engine Oil Filter Differential Pressure Shutdown Event Response Configuration		X	X	X		X	X	X	
High Starting Air Pressure Warning Event Response Configuration	X	X				X	X		
High Starting Air Pressure Shutdown Event Response Configuration		X	X	X		X	X		
Low Starting Air Pressure Warning Event Response Configuration	X	X				X	X	X	
Low Starting Air Pressure Shutdown Event Response Configuration		X	X	X		X	X	X	

<sup>(17)</sup> Each setpoint in the Engine Protection Events Configuration block is used in order to program a system response to the associated Suspect Parameter Number/Failure Mode Identifier (SPN/FMI) for any internal source.

Table 56 lists the available options for each "TEMPERATURE" setpoint. The options that are available for each setpoint are designated by an "X" in the option column.

Table 56

<b>"TEMPERATURE" Setpoints - Engine Protection Events Configuration<sup>(17)</sup></b>									
<b>Setpoint Name</b>	<b>Warning</b>	<b>Audible Alert</b>	<b>Soft Shutdown</b>	<b>Hard Shutdown</b>	<b>Loss of Utility</b>	<b>Breaker Trip #1</b>	<b>Breaker Trip #2</b>	<b>FPT</b>	<b>Active Only</b>
High Engine Coolant Temperature Warning Event Response Configuration	X	X				X	X	X	
High Engine Coolant Temperature Shutdown Event Response Configuration		X	X	X		X	X	X	
Low Engine Coolant Temperature Warning Event Response Configuration	X	X				X	X	X	
High Engine Oil Temperature Warning Event Response Configuration	X	X				X	X	X	
High Engine Oil Temperature Shutdown Event Response Configuration		X	X	X		X	X	X	
Low Engine Oil Temperature Warning Event Response Configuration	X	X				X	X	X	
Low Engine Oil Temperature Shutdown Event Response Configuration		X	X	X		X	X	X	
High Exhaust Temperature Warning Event Response Configuration	X	X				X	X	X	
High Exhaust Temperature Shutdown Event Response Configuration		X	X	X		X	X	X	

(continued)

(Table 56, contd)

<b>"TEMPERATURE" Setpoints - Engine Protection Events Configuration<sup>(17)</sup></b>									
<b>Setpoint Name</b>	<b>Warning</b>	<b>Audible Alert</b>	<b>Soft Shutdown</b>	<b>Hard Shutdown</b>	<b>Loss of Utility</b>	<b>Breaker Trip #1</b>	<b>Breaker Trip #2</b>	<b>FPT</b>	<b>Active Only</b>
Low Exhaust Temperature Warning Event Response Configuration	X	X				X	X	X	
Low Exhaust Temperature Shutdown Event Response Configuration		X	X	X		X	X	X	
High Right Exhaust Temperature Warning Event Response Configuration	X	X				X	X	X	
High Right Exhaust Temperature Shutdown Event Response Configuration		X	X	X		X	X	X	
Low Right Exhaust Temperature Warning Event Response Configuration	X	X				X	X	X	
Low Right Exhaust Temperature Shutdown Event Response Configuration		X	X	X		X	X	X	
High Left Exhaust Temperature Warning Event Response Configuration	X	X				X	X	X	
High Left Exhaust Temperature Shutdown Event Response Configuration		X	X	X		X	X	X	

(continued)

(Table 56, contd)

<b>"TEMPERATURE" Setpoints - Engine Protection Events Configuration<sup>(17)</sup></b>									
<b>Setpoint Name</b>	<b>Warning</b>	<b>Audible Alert</b>	<b>Soft Shutdown</b>	<b>Hard Shutdown</b>	<b>Loss of Utility</b>	<b>Breaker Trip #1</b>	<b>Breaker Trip #2</b>	<b>FPT</b>	<b>Active Only</b>
Low Left Exhaust Temperature Warning Event Response Configuration	X	X				X	X	X	
Low Left Exhaust Temperature Shutdown Event Response Configuration		X	X	X		X	X	X	

<sup>(17)</sup> Each setpoint in the Engine Protection Events Configuration block is used in order to program a system response to the associated Suspect Parameter Number/Failure Mode Identifier (SPN/FMI) for any internal source.

Table 57 lists the available options for each "LEVEL" setpoint. The options that are available for each setpoint are designated by an "X" in the option column.

Table 57

<b>"LEVEL" Setpoints - Engine Protection Events Configuration<sup>(17)</sup></b>									
<b>Setpoint Name</b>	<b>Warning</b>	<b>Audible Alert</b>	<b>Soft Shutdown</b>	<b>Hard Shutdown</b>	<b>Loss of Utility</b>	<b>Breaker Trip #1</b>	<b>Breaker Trip #2</b>	<b>FPT</b>	<b>Active Only</b>
High Engine Coolant Level Warning Event Response Configuration	X	X				X	X		
High Engine Coolant Level Shutdown Event Response Configuration		X	X	X		X	X		
Low Engine Coolant Level Warning Event Response Configuration	X	X				X	X		
Low Engine Coolant Level Shutdown Event Response Configuration		X	X	X		X	X		
High Engine Oil Level Warning Event Response Configuration	X	X				X	X		

(continued)

(Table 57, contd)

<b>"LEVEL" Setpoints - Engine Protection Events Configuration<sup>(17)</sup></b>									
<b>Setpoint Name</b>	<b>Warning</b>	<b>Audible Alert</b>	<b>Soft Shutdown</b>	<b>Hard Shutdown</b>	<b>Loss of Utility</b>	<b>Breaker Trip #1</b>	<b>Breaker Trip #2</b>	<b>FPT</b>	<b>Active Only</b>
High Engine Oil Level Shutdown Event Response Configuration		X	X	X		X	X		
Low Engine Oil Level Warning Event Response Configuration	X	X				X	X		
Low Engine Oil Level Shutdown Event Response Configuration		X	X	X		X	X		
High Fuel Level Warning Event Response Configuration	X	X				X	X		
High Fuel Level Shutdown Event Response Configuration		X	X	X		X	X		
Low Fuel Level Warning Event Response Configuration	X	X				X	X		
Low Fuel Level Shutdown Event Response Configuration		X	X	X		X	X		
External Tank High Fuel Level Warning Event Response Configuration	X	X				X	X		
External Tank High Fuel Level Shutdown Event Response Configuration		X	X	X		X	X		

(continued)

(Table 57, contd)

<b>"LEVEL" Setpoints - Engine Protection Events Configuration<sup>(17)</sup></b>									
<b>Setpoint Name</b>	<b>Warning</b>	<b>Audible Alert</b>	<b>Soft Shutdown</b>	<b>Hard Shutdown</b>	<b>Loss of Utility</b>	<b>Breaker Trip #1</b>	<b>Breaker Trip #2</b>	<b>FPT</b>	<b>Active Only</b>
External Tank Low Fuel Level Warning Event Response Configuration	X	X				X	X		
External Tank Low Fuel Level Shutdown Event Response Configuration		X	X	X		X	X		

<sup>(17)</sup> Each setpoint in the Engine Protection Events Configuration block is used in order to program a system response to the associated Suspect Parameter Number/Failure Mode Identifier (SPN/FMI) for any internal source.

Table 58 lists the available options for each of the "OTHER" setpoints. The options that are available for each setpoint are designated by an "X" in the option column.

Table 58

<b>"OTHER" Setpoints - Engine Protection Events Configuration<sup>(17)</sup></b>									
<b>Setpoint Name</b>	<b>Warning</b>	<b>Audible Alert</b>	<b>Soft Shutdown</b>	<b>Hard Shutdown</b>	<b>Loss of Utility</b>	<b>Breaker Trip #1</b>	<b>Breaker Trip #2</b>	<b>FPT</b>	<b>Active Only</b>
Air Damper Closed Event Response Configuration		X		X					X
Emergency Stop Shutdown Event Response Configuration		X		X <sup>(16)</sup>		X	X		
Engine Failure to Start Shutdown Event Response Configuration		X		X <sup>(16)</sup>		X	X		
Unexpected Engine Shutdown Event Response Configuration		X		X <sup>(16)</sup>		X	X		
Engine Over Speed Shutdown Event Response Configuration		X		X <sup>(16)</sup>		X	X		
Engine Under Speed Warning Event Response Configuration	X	X				X	X	X	
Engine Under Speed Shutdown Event Response Configuration		X	X	X		X	X	X	
Fuel Tank Leak Event Response Configuration	X	X	X	X		X	X		
Service Maintenance Interval Warning Event Response Configuration	X	X							

<sup>(17)</sup> Each setpoint in the Engine Protection Events Configuration block is used in order to program a system response to the associated Suspect Parameter Number/Failure Mode Identifier (SPN/FMI) for any internal source.

<sup>(16)</sup> Setpoint is not adjustable

## Generator Protection Events Configuration

 **WARNING**

**Warning and/or shutdown events should not be disabled. If warning or shutdown events are disabled, the user may not be aware of conditions that could cause damage to the engine, generator, or electrical loads. If warning or shutdown events are disabled, make sure that there is another control that is set up that can diagnose the event, and if necessary, will shut the engine down.**

The Generator Protection Events Configuration block is used in order to configure the desired response for any engine protection event generated by the genset control.

**Note:** Table 59 lists the available options for each setpoint number. The options that are available for each setpoint are designated by an "X" in the option column.

Table 59

Setpoints - Generator Protection Events Configuration <sup>(18)</sup>									
Setpoint Name	Warning	Audible Alert	Soft Shutdown	Hard Shutdown	Loss of Utility	Breaker Trip #1	Breaker Trip #2	FPT	Active Only
Earth Fault Event Response Configuration	X	X	X	X		X	X		
High Generator Winding #1 Temperature Warning Event Response Configuration	X	X				X	X	X	
High Generator Winding #1 Temperature Shutdown Event Response Configuration		X	X	X		X	X	X	
High Generator Winding #2 Temperature Warning Event Response Configuration	X	X				X	X	X	

(continued)

(Table 59, contd)

Setpoints - Generator Protection Events Configuration <sup>(18)</sup>									
Setpoint Name	Warning	Audible Alert	Soft Shutdown	Hard Shutdown	Loss of Utility	Breaker Trip #1	Breaker Trip #2	FPT	Active Only
High Generator Winding #2 Temperature Shutdown Event Response Configuration		X	X	X		X	X	X	
High Generator Winding #3 Temperature Warning Event Response Configuration	X	X				X	X	X	
High Generator Winding #3 Temperature Shutdown Event Response Configuration		X	X	X		X	X	X	
High Generator Bearing #1 Temperature Warning Event Response Configuration	X	X				X	X	X	
High Generator Bearing #1 Temperature Shutdown Event Response Configuration		X	X	X		X	X	X	
Low Generator Bearing #1 Temperature Warning Event Response Configuration	X	X				X	X	X	
Low Generator Bearing #1 Temperature Shutdown Event Response Configuration		X	X	X		X	X	X	

(continued)

(Table 59, contd)

<b>Setpoints - Generator Protection Events Configuration<sup>(18)</sup></b>									
<b>Setpoint Name</b>	<b>Warning</b>	<b>Audible Alert</b>	<b>Soft Shutdown</b>	<b>Hard Shutdown</b>	<b>Loss of Utility</b>	<b>Breaker Trip #1</b>	<b>Breaker Trip #2</b>	<b>FPT</b>	<b>Active Only</b>
Generator Over Current (Amp) Warning Event Response Configuration	X	X				X	X		
Generator Over Current (Amp) Shutdown Event Response Configuration		X	X	X		X	X		
Generator Over Frequency Warning Event Response Configuration	X	X				X	X		
Generator Over Frequency Shutdown Event Response Configuration		X	X	X		X	X		
Generator Under Frequency Warning Event Response Configuration	X	X				X	X	X	
Generator Under Frequency Shutdown Event Response Configuration		X	X	X		X	X	X	
Generator Reverse Power Warning Event Response Configuration	X	X				X	X		
Generator Reverse Power Shutdown Event Response Configuration		X	X	X		X	X		
Generator Over Voltage Warning Event Response Configuration	X	X				X	X		

(continued)

(Table 59, contd)

Setpoints - Generator Protection Events Configuration <sup>(18)</sup>									
Setpoint Name	Warning	Audible Alert	Soft Shutdown	Hard Shutdown	Loss of Utility	Breaker Trip #1	Breaker Trip #2	FPT	Active Only
Generator Over Voltage Shutdown Event Response Configuration		X	X	X		X	X		
Generator Under Voltage Warning Event Response Configuration	X	X				X	X	X	
Generator Under Voltage Shutdown Event Response Configuration		X	X	X		X	X	X	

<sup>(18)</sup> Each setpoint in the "Generator Protection Events Configuration" block is used in order to program a system response to the associated Suspect Parameter Number/Failure Mode Identifier (SPN/FMI) for any internal source.

### Other System Events Configuration



**Warning and/or shutdown events should not be disabled. If warning or shutdown events are disabled, the user may not be aware of conditions that could cause damage to the engine, generator, or electrical loads. If warning or shutdown events are disabled, make sure that there is another control that is set up that can diagnose the event, and if necessary, will shut the engine down.**

The "Other System Events Configuration" block is used in order to configure the desired response for any engine protection event generated by the genset control.

**Note:** Table 60 lists the available options for each setpoint number. The options that are available for each setpoint are designated by an "X" in the option column.

Table 60

Setpoints - Other System Events Configuration <sup>(19)</sup>									
Setpoint Name	Warning	Audible Alert	Soft Shutdown	Hard Shutdown	Loss of Utility	Breaker Trip #1	Breaker Trip #2	FPT	Active Only
High Ambient Air Temperature Warning Event Response Configuration	X	X				X	X	X	
High Ambient Air Temperature Shutdown Event Response Configuration		X	X	X		X	X	X	
Low Ambient Air Temperature Warning Event Response Configuration	X	X				X	X		
Low Ambient Air Temperature Shutdown Event Response Configuration		X	X	X		X	X		
Automatic Transfer Switch in Normal Position Event Response Configuration	X	X							X
Automatic Transfer Switch in Emergency Position Event Response Configuration	X	X							X
Battery Charger Failure Diagnostic Response Configuration	X	X							X
High Battery Voltage Warning Event Response Configuration	X	X				X	X		

(continued)

(Table 60, contd)

Setpoints - Other System Events Configuration <sup>(19)</sup>									
Setpoint Name	Warning	Audible Alert	Soft Shutdown	Hard Shutdown	Loss of Utility	Breaker Trip #1	Breaker Trip #2	FPT	Active Only
High Battery Voltage Shutdown Event Response Configuration		X	X	X		X	X		
Low Battery Voltage Warning Event Response Configuration	X	X				X	X	X	
Low Battery Charging System Voltage Warning Event Response Configuration	X	X				X	X	X	
Generator Breaker Failure to Open Event Response Configuration	X	X		X		X	X		
Generator Breaker Failure to Close Event Response Configuration	X	X		x		X	X		
Generator Breaker Open Event Response Configuration	X	X							X
Generator Breaker Closed Event Response Configuration	X	X							X
Utility Breaker Failure to Open Event Response Configuration	X	X		X		X	X		
Utility Breaker Failure to Close Event Response Configuration	X	X		X		X	X		

(continued)

(Table 60, contd)

Setpoints - Other System Events Configuration <sup>(19)</sup>									
Setpoint Name	Warning	Audible Alert	Soft Shutdown	Hard Shutdown	Loss of Utility	Breaker Trip #1	Breaker Trip #2	FPT	Active Only
Utility Breaker Open Event Response Configuration	X	X							X
Utility Breaker Closed Event Response Configuration	X	X							X
Emergency Shutdown Override Mode Active Warning Event Response Configuration	X <sup>(16)</sup>	X							
Engine in Cooldown Event Response Configuration	X	X							X
Engine Speed-Generator Output Frequency Mismatch Warning Event Response Configuration	X	X				X	X		
Custom Event #1 High Warning Event Response Configuration	X	X				X	X	X	
Custom Event #1 High Shutdown Event Response Configuration		X	X	X		X	X	X	
Custom Event #1 Low Warning Event Response Configuration	X	X				X	X	X	
Custom Event #1 Low Shutdown Event Response Configuration		X	X	X		X	X	X	

(continued)

(Table 60, contd)

<b>Setpoints - Other System Events Configuration<sup>(19)</sup></b>									
<b>Setpoint Name</b>	<b>Warning</b>	<b>Audible Alert</b>	<b>Soft Shutdown</b>	<b>Hard Shutdown</b>	<b>Loss of Utility</b>	<b>Breaker Trip #1</b>	<b>Breaker Trip #2</b>	<b>FPT</b>	<b>Active Only</b>
Custom Event #1 Event Response Configuration	X	X	X	X	X	X	X	X	X
Custom Event #2 High Warning Event Response Configuration	X	X				X	X	x	
Custom Event #2 High Shutdown Event Response Configuration		X	X	X		X	X	X	
Custom Event #2 Low Warning Event Response Configuration	X	X				X	X	X	
Custom Event #2 Low Shutdown Event Response Configuration		X	X	X		X	X	X	
Custom Event #2 Event Response Configuration	X	X	X	X	X	X	X	X	X
Custom Event #3 High Warning Event Response Configuration	X	X				X	X	X	
Custom Event #3 High Shutdown Event Response Configuration		X	X	X		X	X	X	
Custom Event #3 Low Warning Event Response Configuration	X	X				X	X	X	

(continued)

(Table 60, contd)

<b>Setpoints - Other System Events Configuration<sup>(19)</sup></b>									
<b>Setpoint Name</b>	<b>Warning</b>	<b>Audible Alert</b>	<b>Soft Shutdown</b>	<b>Hard Shutdown</b>	<b>Loss of Utility</b>	<b>Breaker Trip #1</b>	<b>Breaker Trip #2</b>	<b>FPT</b>	<b>Active Only</b>
Custom Event #3 Low Shutdown Event Response Configuration		X	X	X		X	X	X	
Custom Event #3 Event Response Configuration	X	X	X	X	X	X	X	X	X
Custom Event #4 High Warning Event Response Configuration	X	X				X	X	X	
Custom Event #4 High Shutdown Event Response Configuration		X	X	X		X	X	X	
Custom Event #4 Low Warning Event Response Configuration	X	X				X	X	X	
Custom Event #4 Low Shutdown Event Response Configuration		X	X	X		X	X	X	
Custom Event #4 Event Response Configuration	X	X	X	X	X	X	X	X	X
Custom Event #5 High Warning Event Response Configuration	X	X				X	X	X	
Custom Event #5 High Shutdown Event Response Configuration		X	X	X		X	X	X	
Custom Event #5 Low Warning Event Response Configuration	X	X				X	X	X	

(continued)

(Table 60, contd)

Setpoints - Other System Events Configuration <sup>(19)</sup>									
Setpoint Name	Warning	Audible Alert	Soft Shutdown	Hard Shutdown	Loss of Utility	Breaker Trip #1	Breaker Trip #2	FPT	Active Only
Custom Event #5 Low Shutdown Event Response Configuration		X	X	X		X	X	X	
Custom Event #5 Event Response Configuration	X	X	X	X	X	X	X	X	X
Custom Event #6 High Warning Event Response Configuration	X	X				X	X	X	
Custom Event #6 High Shutdown Event Response Configuration		X	X	X		X	X	X	
Custom Event #6 Low Warning Event Response Configuration	X	X				X	X	X	
Custom Event #6 Low Shutdown Event Response Configuration		X	X	X		X	X	X	
Custom Event #6 Event Response Configuration	X	X	X	X	X	X	X	X	X
Custom Event #7 High Warning Event Response Configuration	X	X				X	X	X	
Custom Event #7 High Shutdown Event Response Configuration		X	X	X		X	X	X	

(continued)

(Table 60, contd)

<b>Setpoints - Other System Events Configuration<sup>(19)</sup></b>									
<b>Setpoint Name</b>	<b>Warning</b>	<b>Audible Alert</b>	<b>Soft Shutdown</b>	<b>Hard Shutdown</b>	<b>Loss of Utility</b>	<b>Breaker Trip #1</b>	<b>Breaker Trip #2</b>	<b>FPT</b>	<b>Active Only</b>
Custom Event #7 Low Warning Event Response Configuration	X	X				X	X	X	
Custom Event #7 Low Shutdown Event Response Configuration		X	X	X		X	X	X	
Custom Event #7 Event Response Configuration	X	X	X	X	X	X	X	X	X
Custom Event #8 High Warning Event Response Configuration	X	X				X	X	X	
Custom Event #8 High Shutdown Event Response Configuration		X	X	X		X	X	X	
Custom Event #8 Low Warning Event Response Configuration	X	X				X	X	X	
Custom Event #8 Low Shutdown Event Response Configuration		X	X	X		X	X	X	
Custom Event #8 Event Response Configuration	X	X	X	X	X	X	X	X	X
High Fire Extinguisher Pressure Warning Event Response Configuration	X	X				X	X		

(continued)

(Table 60, contd)

<b>Setpoints - Other System Events Configuration<sup>(19)</sup></b>									
<b>Setpoint Name</b>	<b>Warning</b>	<b>Audible Alert</b>	<b>Soft Shutdown</b>	<b>Hard Shutdown</b>	<b>Loss of Utility</b>	<b>Breaker Trip #1</b>	<b>Breaker Trip #2</b>	<b>FPT</b>	<b>Active Only</b>
High Fire Extinguisher Pressure Shutdown Event Response Configuration		X	X	X		X	X		
Low Fire Extinguisher Pressure Warning Event Response Configuration	X	X				X	X	X	
Low Fire Extinguisher Pressure Shutdown Event Response Configuration		X	X	X		X	X	X	
Generator Control Not in Automatic Warning Event Response Configuration	X	X							X
Loss of Utility Event Response Configuration	X	X							X
Utility to Generator Transfer Failure Warning Event Response Configuration	X	X				X	X		

(continued)

(Table 60, contd)

Setpoints - Other System Events Configuration <sup>(19)</sup>									
Setpoint Name	Warning	Audible Alert	Soft Shutdown	Hard Shutdown	Loss of Utility	Breaker Trip #1	Breaker Trip #2	FPT	Active Only
Utility to Generator Transfer Failure Shutdown Event Response Configuration		X	X			X	X		
Generator to Utility Transfer Failure Warning Event Response Configuration	X	X				X	X		

<sup>(19)</sup> Each setpoint in the "Other System Events Configuration" block is used in order to program a system response to the associated Suspect Parameter Number/Failure Mode Identifier (SPN/FMI) for any internal source.

<sup>(16)</sup> Setpoint Is not adjustable

## Event Input Functions

The Event Input Function block allows the user of the genset to define selected inputs to cause user-defined events to become active.

Table 61

Setpoints - Custom Events <sup>(13)</sup>					
Setpoint Name	Min Value	Max Value	Units	Factory Default	Description
Custom Event #NN Active State Configuration	N/A	N/A	N/A	High	Settings for custom events #1- #16
Custom Event #NN Event Notification Delay Time	0	250	sec.	0	Settings for custom events #1- #16
Custom Event #NN Suspect Parameter Number	N/A	N/A	N/A	107	Settings for custom events #1- #16
Custom Event #NN Failure Mode Identifier	0	20	N/A	15	Settings for custom events #1- #16

<sup>(13)</sup> The setpoints that are stored or the setpoints that are being programmed must match the specified setpoints of the particular generator set.

## Event Output Functions

The Event Output function block provides a method to access the active status of an event for use in configuration logic

Table 62

Setpoints - Event Output Functions <sup>(14)</sup>					
Setpoint Name	Min Value	Max Value	Units	Factory Default	Description
Event Output Function #NN Trigger Condition	N/A	N/A	N/A	Disabled	Settings for event output functions #1- #30
Event Output Function #NN Suspect Parameter Number	N/A	N/A	N/A	100	Settings for event output functions #1- #30

<sup>(14)</sup> The setpoints that are stored or the setpoints that are being programmed must match the specified setpoints of the particular generator set.

## Event System

Event System block provides a method to log system events to non-volatile memory. The Event System block also manages the status of the events in order to provide overall status outputs to the system.

Table 63

Setpoints - Event System <sup>(20)</sup>					
Setpoint Name	Min Value	Max Value	Units	Factory Default	Description
Event Warning Condition Response Auto Reset Enable Status	N/A	N/A	N/A	Enabled	
Event Audible Alert Response Auto Reset Enable Status	N/A	N/A	N/A	Enabled	
Event Loss of Utility Response Auto Reset Enable Status	N/A	N/A	N/A	Enabled	
Event Breaker #1 Trip Response Auto Reset Enable Status	N/A	N/A	N/A	Enabled	
Event Breaker #2 Trip Response Auto Reset Enable Status	N/A	N/A	N/A	Enabled	

<sup>(20)</sup> The setpoints that are stored or the setpoints that are being programmed must match the specified setpoints of the particular generator set.

## GEN MONITOR / PROTECT

### Enhanced Generator Monitor

The Enhanced Generator Monitor block provides a method to access the generator monitored parameters from the Accessory Data Link for use in configuration logic. The following generator values will be monitored:

- Front bearing temperature
- Rear bearing temperature
- Winding #1 temperature
- Winding #2 temperature
- Winding #3 temperature

Table 64

<b>Setpoints - Enhanced Generator Monitor<sup>(31)</sup></b>					
<b>Setpoint Name</b>	<b>Min Value</b>	<b>Max Value</b>	<b>Units</b>	<b>Factory Default</b>	<b>Description</b>
Generator Winding Temperature Sensor Installation Status	N/A	N/A	N/A	Not Installed	Set to "Installed" when a temperature module is installed on the accessory data link
Number of Generator Bearing Temperature Sensors	0	2	N/A	Not Installed	

<sup>(31)</sup> The setpoints that are stored or the setpoints that are being programmed must match the specified setpoints of the particular generator set.

### **Generator AC Monitor**

The Generator AC Monitor block measures the AC voltage and current output by the generator. The following generator values will be monitored:

- True RMS line - line voltages
- Average line - line voltage
- True RMS line - neutral voltages (for star/wye configurations)
- Average line-neutral voltage (for star/wye configurations)
- True RMS phase currents
- Average phase current
- Generator output frequency

Table 65

Setpoints - Generator AC Monitor <sup>(21)</sup>					
Setpoint Name	Min Value	Max Value	Units	Factory Default	Description
Generator Connection Configuration	N/A	N/A	N/A	Star/Wye	Configurations can be: "Star/Wye", "Delta/3 Wire" "Delta/4 Wire" "Single Phase 2 Wire" "Single Phase 3 Wire"
Generator Potential Transformer Primary Winding Rating	1	50000	V	1	For direct sensing, leave at default value. For an application requiring a potential transformer, set to transformer primary winding value.
Generator Potential Transformer Secondary Winding Rating	1	240	V	1	For direct sensing, leave at default value. For an application requiring a potential transformer, set to transformer secondary winding value
Generator Current Transformer Primary Winding Rating	1	7000	A	75	Set to current transformer primary winding value
Generator Current Transformer Secondary Winding Rating	1	5	A	5	Can only be set to 1 or 5
Number of Generator Poles	0	200	N/A	4	
Generator Rated Frequency	50	60	Hz	60	
Generator Rated Voltage	100	50000	V	100	
Generator Rated Power	1	50000	kW	1	
Generator Rated Apparent Power	1	50000	kVA	1	

<sup>(21)</sup> The setpoints that are stored or the setpoints that are being programmed must match the specified setpoints of the particular generator set.

**Generator AC Power Monitor**

The Generator AC Power Monitor Block measures all generator power quantities following generator values will be monitored:

- Per phase kW (for star/wye configurations)
- Total kW
- Total kW hours imported
- Total kW hours exported
- Percent kW output
- Per phase kVAr (for star/wye configurations)
- Total kVAr
- Total kVAr hours imported
- Total kVAr hours imported
- Percent kVAr output
- Per phase kVA (for star/wye configurations)
- Total kVA
- Percent kVA output
- Per phase genset output Power Factor with lead/lag indication (for star/wye configurations)
- Average output Power Factor with lead/lag indication

**Note:** Per phase quantities (kW, kVAr, KVA, and Power Factor) will be monitored for 3-phase, 4-wire star-connected configurations)

Table 66

Setpoints - Generator AC Power Monitor <sup>(31)</sup>					
Setpoint Name	Min Value	Max Value	Units	Factory Default	Description
Customer Password Security Level to Reset Generator Energy Meters	0	4	N/A	0.3	

<sup>(31)</sup> The setpoints that are stored or the setpoints that are being programmed must match the specified setpoints of the particular generator set.

### Generator Over Current

The generator overcurrent block detects an overcurrent condition that persists for a duration that is a function of the overcurrent level or a condition that exceeds a threshold for a programmed duration.

Table 67

Setpoints - Generator Over Current <sup>(23)</sup>					
Setpoint Name	Min Value	Max Value	Units	Factory Default	Description
Generator Definite Time Over Current (Amp) Warning Event Percentage Threshold	80	130	%	105	Threshold for the Over Current Warning
Generator Inverse Time Over Current (Amp) Shutdown Event Time Multiplier	0.05	10.00	N/A	0.27	Time multiplier setpoint (TM) used in equation shown in Illustration 27
Generator Definite Time Over Current (Amp) Shutdown Event Percentage Threshold	100	300	%	110	If current is above this setpoint value for the specified time (setpoint #4) there will be an overcurrent shutdown.
Generator Definite Time Over Current (Amp) Shutdown Event Notification Delay Time	0.1	20.0	sec.	10	Time delay for setpoint #3

<sup>(23)</sup> The setpoints that are stored or the setpoints that are being programmed must match the specified setpoints of the particular generator set.

### Generator Over / Under Frequency

The Generator Over/Under Frequency block detects bus frequency above or below programmable thresholds for a programmable duration and activates an alarm.

#### Time Multiplier Setpoint (TM)

$$\text{Trip Time} = (\text{TM} \times 0.14) \div ((I/I_s)^{0.02} - 1)$$

Where:

I = Fault Current = Level of current above Definite Time Warning Threshold and below Definite Time Shutdown Threshold

UNIT OF MEASURE IS % OF RATED CURRENT

I<sub>s</sub> = Starting current = Same as Definite Time Warning Threshold

UNIT OF MEASURE IS % OF RATED CURRENT

Illustration 27

g01239796

Table 68

<b>Setpoints - Generator Over / Under Frequency<sup>(24)</sup></b>					
<b>Setpoint Name</b>	<b>Min Value</b>	<b>Max Value</b>	<b>Units</b>	<b>Factory Default</b>	<b>Description</b>
Generator Over Frequency Warning Event Percentage Threshold	80	120	%	105	
Generator Over Frequency Warning Event Notification Delay Time	0	120	sec.	10	
Generator Over Frequency Shutdown Event Percentage Threshold	80.0	120	%	110	
Generator Over Frequency Shutdown Event Notification Delay Time	0	120	sec.	10	
Generator Under Frequency Warning Event Percentage Threshold	80.0	120.0	%	95.0	
Generator Under Frequency Warning Event Notification Delay Time	0	120	sec.	10	
Generator Under Frequency Shutdown Event Percentage Threshold	80.0	120.0	%	90.0	
Generator Under Frequency Shutdown Event Notification Delay Time	0	120	sec.	15	

<sup>(24)</sup> The setpoints that are stored or the setpoints that are being programmed must match the specified setpoints of the particular generator set.

### Generator Over / Under voltage

The Generator Over/Under Voltage block detects generator output voltage above or below programmable thresholds for a programmable duration and activates an alarm.

Table 69

<b>Setpoints - Generator Over / Under Voltage<sup>(25)</sup></b>					
<b>Setpoint Name</b>	<b>Min Value</b>	<b>Max Value</b>	<b>Units</b>	<b>Factory Default</b>	<b>Description</b>
Generator Over Voltage Warning Event Percentage Threshold	100	125	%	105	
Generator Over Voltage Warning Event Notification Delay Time	0	120	sec.	10	
Generator Over Voltage Shutdown Event Percentage Threshold	100	125	%	110	
Generator Over Voltage Shutdown Event Notification Delay Time	0	120	sec.	10	
Generator Under Voltage Warning Event Percentage Threshold	60	100	%	90.0	
Generator Under Voltage Warning Event Notification Delay Time	0	120	sec.	10	
Generator Under Voltage Shutdown Event Threshold	60	100	%	85.0	
Generator Under Voltage Shutdown Event Notification Delay Time	0	120	sec.	15	

<sup>(25)</sup> The setpoints that are stored or the setpoints that are being programmed must match the specified setpoints of the particular generator set.

## Generator Reverse Power

The Generator Reverse Power block detects a reverse power condition that persists for a duration above a programmed level.

Table 70

Setpoints - Generator Reverse Power <sup>(26)</sup>					
Setpoint Name	Min Value	Max Value	Units	Factory Default	Description
Generator Reverse Power Warning Event Percentage Threshold	1	20	%	5	
Generator Reverse Power Warning Event Notification Delay Time	0	30	sec.	10	
Generator Reverse Power Shutdown Event Percentage Threshold	1	20	%	15	
Generator Reverse Power Shutdown Event Notification Delay Time	0	30	sec.	10	

<sup>(26)</sup> The setpoints that are stored or the setpoints that are being programmed must match the specified setpoints of the particular generator set.

## DISCRETE INPUT/OUTPUT (I/O)

### Digital Inputs

The Digital Input block is used in order to relay on/off information such as switch closures to the EMCP 3.

**Note:** There are eight digital inputs on “EMCP 3.2” and “EMCP 3.3”. There are six digital inputs on “EMCP 3.1.”

Table 71

Setpoints - Digital Inputs <sup>(5)</sup>					
Setpoint Name	Min Value	Max Value	Units	Factory Default	Description
E-STOP	Active Low	Active High	N/A	Active High	Activating the E-STOP input will cause the generator set to stop immediately.
REMOTE INITIATE	Active Low	Active High	N/A	Active Low	Setpoint allows for starting and stopping the genset from a remote location. If input is active and the engine mode switch is in "AUTO", the engine will attempt to start and run. Once the input becomes inactive, the engine will enter into cooldown (if programmed) and then STOP.
Digital #3 <sup>(6)</sup>	Active Low	Active High	N/A	Active Low	The inputs can be set to any of the values listed in Table 72
Digital #4 <sup>(6)</sup>	Active Low	Active High	N/A	Active Low	
Digital #5 <sup>(6)</sup>	Active Low	Active High	N/A	Active Low	
Digital #6 <sup>(6)</sup>	Active Low	Active High	N/A	Active Low	
Digital #7 <sup>(6)</sup>	Active Low	Active High	N/A	Active Low	
Digital #8 <sup>(6)</sup>	Active Low	Active High	N/A	Active Low	

<sup>(5)</sup> The setpoints that are stored or the setpoints that are being programmed must match the specified setpoints of the particular generator set.

<sup>(6)</sup> The "Digital Inputs" parameter can only be set to "Active High" or "Active Low" in order to initiate a High Warning, Low Warning, High Shutdown, Low Shutdown, or Status.

Table 72

Available Digital Inputs	
<b>Pressures</b> Air Filter Differential Pressure Engine Oil Pressure Fire Extinguisher Pressure Fuel Filter Differential Pressure Oil Filter Differential Pressure Starting Air Pressure Gas Pressure	<b>Other</b> Air Damper Closed ATS in Normal Position ATS in Emergency Position Battery Charger Failure Battery Charging System Voltage Battery Voltage Fuel Leak Detected Custom Event Earth Fault Earth Leakage Generator Frequency Generator Voltage Generator Current Generator Power Loss of Utility Utility of Generator Transfer Failure Generator to Utility Transfer Failure
<b>Temperatures</b> Ambient Air Temperature Engine Coolant Temperature Engine Oil Temperature Exhaust Temperature Rear Bearing Temperature Right Exhaust Temperature Left Exhaust Temperature	
<b>Levels</b> Engine Coolant Level Engine Oil Level Fuel Level External Tank Fuel Level	

### Digital Outputs

The Digital Output block is used in order to relay on/off information from the EMCP 3 for purposes such as operating relays, solenoids and indicator lamps.

There are two digital outputs on "EMCP 3.3". There is one digital output on "EMCP 3.2". There are no digital outputs on "EMCP 3.1"

Table 73

Setpoints - Digital Outputs <sup>(7)</sup>					
Setpoint Name	Min Value	Max Value	Units	Factory Default	Description
Digital Output #1 Active State Configuration	Low	High	N/A	Low	
Digital Output #2 Active State Configuration	Low	High	N/A	Low	

<sup>(7)</sup> The setpoints that are stored or the setpoints that are being programmed must match the specified setpoints of the particular generator set.

### Relay Outputs

The Relay Output block is used in order to relay on/off information from the EMCP 3 for purposes such as operating relays, solenoids and indicator lamps.

There are eight relay outputs on the EMCP 3.2 and EMCP 3.3. Six of the outputs have normally open contacts and two of the outputs have normally open and normally closed contacts.

There are six normally open relay outputs on the EMCP 3.1. There are no normally closed outputs on the EMCP 3.1

**Note:** The "active" state for relay outputs is not configurable.

Table 74

Setpoints - Relay Outputs <sup>(29)</sup>					
Setpoint Name	Min Value	Max Value	Units	Factory Default	Description
Relay Output #1 Active State Configuration	N/A	N/A	N/A	High	Relay Output #1 is always configured as the "Starter Motor Relay"
Relay Output #2 Active State Configuration	N/A	N/A	N/A	High	Relay #2 is always configured as the "Fuel Control Relay"
Relay Output #3 Active State Configuration	N/A	N/A	N/A	High	Relay Output #3 is controlled by Digital Selector #1
Relay Output #4 Active State Configuration	N/A	N/A	N/A	High	Relay Output #4 is controlled by Digital Selector #2
Relay Output #5 Active State Configuration	N/A	N/A	N/A	High	Relay Output #5 is controlled by Digital Selector #3
Relay Output #6 Active State Configuration	N/A	N/A	N/A	High	Relay Output #6 is controlled by Digital Selector #4 The output can be set to "Active High" or "Active Low"
Relay Output #7 Active State Configuration	N/A	N/A	N/A	High	Relay Output #7 is controlled by Digital Selector #5
Relay Output #8 Active State Configuration	N/A	N/A	N/A	High	Relay Output #8 is controlled by Digital Selector #6

<sup>(29)</sup> The setpoints that are stored or the setpoints that are being programmed must match the specified setpoints of the particular generator set.

### Spare Analog Input

The Spare Analog Input block converts a resistive sender value to engineering units, detects sender diagnostics, and detects a high or low condition on the spare sender input.

**Note:** If you have selected a spare input to be a temperature, setpoints 6, 7, 10, and 11 will not appear since they are associated with pressures and levels. If you have selected a spare input to be a pressure, setpoints 5, 7, 9, and 11 will not appear since they are associated with temperatures and levels. If you have selected a spare input to be a level, setpoints 5, 6, 9, and 10 will not appear since they are associated with temperatures and pressures.

Table 75

Setpoints - Spare Analog Input <sup>(29)</sup>					
Setpoint Name	Min Value	Max Value	Units	Factory Default	Description
Spare Analog Input Enable Status	N/A	N/A	N/A	Enabled	Set to "Enabled" for MUI engines and set to "Disabled" for EUI engines
Spare Analog Input Type Configuration	N/A	N/A	N/A	Temperature	Select "Temperature", "Pressure", or "Level"
Spare Analog Input Suspect Parameter Number (SPN)	N/A	N/A	N/A	175	Oil temperature
Spare Analog Input High Percentage Warning Event Threshold	0	100	%	0	
Spare Analog Input High Temperature Warning Event Threshold	-273	1,735	Deg. C	102 °C (216 °F)	
Spare Analog Input High Pressure Warning Event Threshold	-250	10,000	kPa	-250	
Spare Analog Input High Warning Event Notification Delay Time	0	60	sec.	2	
Spare Analog Input High Percentage Shutdown Event Threshold	0	100	%	0	
Spare Analog Input High Temperature Shutdown Event Threshold	-273	1,735	Deg. C	107 °C (225 °F)	
Spare Analog Input High Pressure Shutdown Event Threshold	-250	10,000	kPa	-250	
Spare Analog Input High Shutdown Event Notification Delay Time	0	60	sec.	10	
Spare Analog Input Low Percentage Warning Event Threshold	0	100	%	100	
Spare Analog Input Low Temperature Warning Event Threshold	-273	1735	Deg. C	1735	
Spare Analog Input Low Warning Event Threshold	-250	10000	kPa	10000	
Spare Analog Input Low Warning Event Notification Delay Time	0	60	sec.	0	
Spare Analog Input Low Percentage Shutdown Event Threshold	0	100	%	100	
Spare Analog Input Low Temperature Shutdown Event Threshold	-273	1735	Deg. C	1735	
Spare Analog Input Low Pressure Shutdown Event Threshold	-250	10000	kPa	10000	
Spare Analog Input Low Shutdown Event Notification Delay Time	0	60	sec.	0	

(29) The setpoints that are stored or the setpoints that are being programmed must match the specified setpoints of the particular generator set.

## NETWORK

### Data Link - SCADA

The SCADA Data Link block is used in order to (communicate with a System Control and Data Acquisition (SCADA) and is used for support of a service tool connection. SCADA Data Link will use the Modbus protocol with an RS-485 half duplex hardware layer operation at a minimum 2400 bps.

Table 76

Setpoints - Data Link - SCADA <sup>(4)</sup>					
Setpoint Name	Min Value	Max Value	Units	Factory Default	Description
SCADA Data Link Baud Rate	2400	57600	N/A	19200	
SCADA Data Link Parity	N/A	N/A	N/A	None	Select "None", "Odd", or "Even"
SCADA Data Link Slave Address	1	247	N/A	1	
SCADA Data Link Access Password	0	0xffff	N/A	0	
SCADA Data Link Connection Timeout Interval	0.1	3600.0	sec.	30	
RS-485 Bias Resistor Enable Status	Disabled	Enabled	N/A	Enabled	

<sup>(4)</sup> The setpoints that are stored or the setpoints that are being programmed must match the specified setpoints of the particular generator set.

## OTHER

### Digital Selectors

The Digital Selector block determines what "EVENTS" or "STATUS" will cause each of the relays to activate.

Table 77

Setpoints - Digital Selectors <sup>(4)</sup>					
Setpoint Name	Min Value	Max Value	Units	Factory Default	Description
Digital Selector #1 Source Configuration				Input #1	Digital Selector #1 controls Relay Output #3 Configuration Options are: Disabled Use Input #1 Use Input #2 Use Input #3 Use Input #4 Use Input #5 Use Data Link Input

(continued)

(Table 77, contd)

Setpoints - Digital Selectors <sup>(6)</sup>					
Setpoint Name	Min Value	Max Value	Units	Factory Default	Description
Digital Selector #2 Source Configuration				Input #4	Digital Selector #2 controls Relay Output #4 Configuration Options are: Disabled Use Input #1 Use Input #2 Use Input #3 Use Input #4 Use Input #5 Use Data Link Input
Digital Selector #3 Source Configuration				Input #6	Digital Selector #3 controls Relay Output #5 Configuration Options are: Disabled Use Input #1 Use Input #2 Use Input #3 Use Input #4 Use Input #5 Use Data Link Input
Digital Selector #4 Source Configuration				Input #6	Digital Selector #4 controls Relay Output #6 Configuration Options are: Disabled Use Input #1 Use Input #2 Use Input #3 Use Input #4 Use Input #5 Use Data Link Input
Digital Selector #5 Source Configuration				Disabled	Digital Selector #5 controls Relay Output #7 Configuration Options are: Disabled Use Input #1 Use Input #2 Use Input #3 Use Input #4 Use Input #5 Use Data Link Input
Digital Selector #6 Source Configuration				Disabled	Digital Selector #6 controls Relay Output #8 Configuration Options are: Disabled Use Input #1 Use Input #2 Use Input #3 Use Input #4 Use Input #5 Use Data Link Input

(continued)

(Table 77, contd)

Setpoints - Digital Selectors <sup>(8)</sup>					
Setpoint Name	Min Value	Max Value	Units	Factory Default	Description
Digital Selector #7 Source Configuration				Input #1	Digital Selector #7 controls Digital Output #1 Configuration Options are: Disabled Use Input #1 Use Input #2 Use Input #3 Use Input #4 Use Input #5 Use Data Link Input
Digital Selector #8 Source Configuration				Disabled	Digital Selector #8 controls Digital Output #2 Configuration Options are: Disabled Use Input #1 Use Input #2 Use Input #3 Use Input #4 Use Input #5 Use Data Link Input

<sup>(8)</sup> The setpoints that are stored or the setpoints that are being programmed must match the specified setpoints of the particular generator set.

### Electronic Control Module Reduced Power Mode

The Electronic Control Module block Reduced Power Mode block minimizes drain on the battery when the engine is stopped and the control is operating in a standby mode.

**Note:** Standard Caterpillar product does not utilize this group of setpoints.

Table 78

Setpoints - Electronic Control Module Reduced Power Mode <sup>(9)</sup>						
Setpoint Name	Min Value	Max Value	Units	Factory Default	Description	
Electronic Control Module Reduced Power Mode Enable Status	Disabled	Enabled	N/A	Disabled	Allows control to go into reduced power mode	
Electronic Control Module Reduced Power Mode Delay Time	0	120	min.	30		

<sup>(9)</sup> The setpoints that are stored or the setpoints that are being programmed must match the specified setpoints of the particular generator set.

### Remote Callback

Remote Callback is used in gensets with a modem connection in order to allow the genset control to dial a programmed telephone number in response to a fault condition. A receiving PC can then query the nature of the fault.

**Note:** Standard Caterpillar product does not utilize this group of setpoints.

Table 79

Setpoints - Remote Callback <sup>(30)</sup>					
Setpoint Name	Min Value	Max Value	Units	Factory Default	Description
Remote Dial Enable Status	N/A	N/A	N/A	Disabled	
Remote Dial Command Configuration	N/A	N/A	N/A	0	

<sup>(30)</sup> The setpoints that are stored or the setpoints that are being programmed must match the specified setpoints of the particular generator set.

i02464721

## Typical Generator Abbreviations

**SMCS Code:** 4490

**A** – Ammeter

**ACT** – Actuator

**ADS** – Engine Combustion Air Damper Position Switch

**AFCR** – Auxiliary Fuel Control Valve

**ALM** – Alarm Module

**ALS** – Alarm Silence Push Button

**ALT** – Alternator

**AR** – Arming Relay

**ASOS** – Air Shutoff Solenoid

**ASR** – Air Shutoff Relay

**ASSV** – Air Start Solenoid Valve

**ATB** – AC Transformer Box

**AUX** – Auxiliary Terminal Strip

**AUXREL** – Auxiliary Relay (Crank Termination)

**AWG** – American Wire Gauge

**BATT** – Battery

**BCF** – Battery Charger Failure Switch

**BTB** – Bus Transformer Box

**C** – Common

**CAM** – Custom Alarm Module

**CAR** – Custom Alarm Relay

**CB** – Circuit Breaker

**CCM** – Customer Communication Module

**CDM** – Engine Cooldown Timer Module

**CIM** – Customer Interface Module

**CT** – Current Transformer

**CTR** – Crank Termination Relay

**D** – Diode

**DCV** – DC Voltmeter

**DS** – Disconnect Switch

**ECLC** – Engine Coolant Loss Sensor Connector

**ECLS** – Engine Coolant Loss Sensor

**ECS** – Engine Control Switch

**ECTS** – Engine Coolant Temperature Sensor

**EFCR** – Emergency Fuel Control Relay

**EFL** – Emergency Fuel Light

**EG** – Electronic Governor (Speed Sensing)

**EGA** – Electronic Governor Actuator

**EGR** – Electronic Governor Relay

**EHC** – Ether Hold-In Coil

**EHS** – Ether Hold-In Switch

**ENFR** – Engine Failure Relay

**EOTC** – Engine Oil Temperature Sensor Connector

**EOTS** – Engine Oil Temperature Sensor

**EOPS** – Engine Oil Pressure Sensor

**EPC** – Ether Pull-In Coil

**EPS** – Ether Pull-In Switch

**ES** – Ether Solenoid

---

<b>ESPB</b> – Emergency Stop Push Button	<b>OCL</b> – Overcrank Light
<b>ESL</b> – Emergency Stop Light	<b>OCR</b> – Overcurrent Relay
<b>F</b> – Fuse	<b>OCT</b> – Overcrank Timer
<b>FCR</b> – Fuel Control Relay	<b>OP</b> – Oil Pressure
<b>FCTM</b> – Fuel Control Timer Module	<b>OPG</b> – Oil Pressure Gauge
<b>FRB</b> – Fuel Rupture Basin	<b>OPL</b> – Oil Pressure Light
<b>FS</b> – Fuel Solenoid	<b>OSL</b> – Overspeed Light
<b>FSOS</b> – Fuel Shutoff Solenoid	<b>OSR</b> – Oil Step Relay
<b>GFR</b> – Generator Fault Relay	<b>OVR</b> – Overvoltage Relay
<b>GOL</b> – Generator On Load	<b>PEEC</b> – Programmable Electronic Engine Control
<b>GOV</b> – Governor	<b>PL</b> – Panel Illumination Light
<b>GPHI</b> – Ground Post (High Voltage)	<b>PLS</b> – Panel Light Switch
<b>GPLO</b> – Ground Post (Low Voltage)	<b>POS</b> – Positive
<b>GS</b> – Governor Switch	<b>POT</b> – Potentiometer
<b>GSC</b> – Generator Set Control	<b>PP</b> – Prelube Pump
<b>GSM</b> – Governor Synchronizing Motor	<b>PPMS</b> – Prelube Pump Magnetic Switch
<b>GSOV</b> – Gas Shutoff Valve	<b>PPPS</b> – Prelube Pump Oil Pressure Switch
<b>HZ</b> – Frequency Meter	<b>PR</b> – Preregulator
<b>KWR</b> – Kilowatt Level Relay	<b>PS</b> – Pinion Solenoid
<b>IC</b> – Remote Start/Stop Initiate Contact	<b>PWM</b> – Electrical Converter (Pulse Width Modulated)
<b>L</b> – Load Leads	<b>RAN</b> – Remote Annunciator
<b>LFL</b> – Low Fuel Level Light	<b>RDM</b> – Relay Driver Module
<b>LFLAS</b> – Low Fuel Level Alarm Switch	<b>RPL</b> – Reverse Power Light
<b>LFS</b> – Latching Fuel Control Solenoid	<b>RPR</b> – Reverse Power Relay
<b>LOLAS</b> – Low Oil Level Alarm Switch	<b>RPSR</b> – Reverse Power Slave Relay
<b>LWLAS</b> – Low Water Level Alarm Switch	<b>RR</b> – Run Relay
<b>LWTL</b> – Low Water Temperature Light	<b>SASV</b> – Start Aid Solenoid Valve
<b>MAN</b> – Manual	<b>SATS</b> – Start Aid Temperature Switch
<b>MPU</b> – Magnetic Speed Pickup	<b>SAS</b> – Starting Aid Switch
<b>NC</b> – Normally Closed	<b>SEC</b> – Second
<b>NO</b> – Normally Open	<b>SHTC</b> – Circuit Breaker Shunt Trip Coil

**SIG** – Signal  
**SL** – Synchronizing Light  
**SLM** – Synchronizing Light Module  
**SLR** – Synchronizing Light Resistor  
**SM** – Starting Motor  
**SMMS** – Starting Motor Magnetic Switch  
**SMR** – Starting Motor Relay  
**SP** – Speed Adjust Potentiometer  
**SPM** – Synchronizing Parallel Module  
**SR** – Slave Relay  
**SS** – Synchronizing Switch  
**T** – Generator Line Leads  
**TD** – Time Delay Relay  
**TSC** – Transfer Switch Position Indicating Contact  
**V** – AC Voltmeter  
**VAR** – Voltage Adjust Rheostat  
**VR** – Voltage Regulator  
**WT** – Water Temperature  
**WTG** – Water Temperature Gauge  
**WTL** – Water Temperature Light  
**XDUCER** – Transducer  
**Z** – Zener Diode

The EMCP 3 control has one 70-pin connector on the back of the control. Not all 70 pins are used. The Illustrations indicated which pins are used and what each pin should be connected to for each version of the control. The Illustrations show all possible connections being used. For EUI engines, the passive analog inputs #1 for oil pressure, and #2 for coolant temperature, will not be used. On EUI engines, utilizing a Common Engine Interface, those sensors will be wired to the engine ECM. The EMCP 3 will get that information from the engine ECM via the Primary J1939 Data Link.

The figures show two different ways to connect the analog inputs. The method shown with all of the other connections is for 2-wire sensors. At the bottom right hand side of the figures, the connections for 1-wire sensors is shown. The discrete inputs are shown connected through normally open contacts to battery negative. These inputs can also be connected through normally closed contacts to battery negative. In order to perform these connections, the active state of the input will need to be set to “active high”.

**Reference:** For information on programming the digital inputs, see Systems Operation, “Digital Input Programming”.

**Reference:** For additional information about the electrical system, refer to the Service Manual Electrical System Schematic for the genset that is being serviced.

i02460269

## ECM Connections

**SMCS Code:** 4490; 7566

The following Illustrations are simplified electrical schematics of the Electronic Control Module (ECM) for the Generator Set. The schematics do not show all possible harness connectors.

Electronic Control Module Wiring Diagram - EMCP 3.1

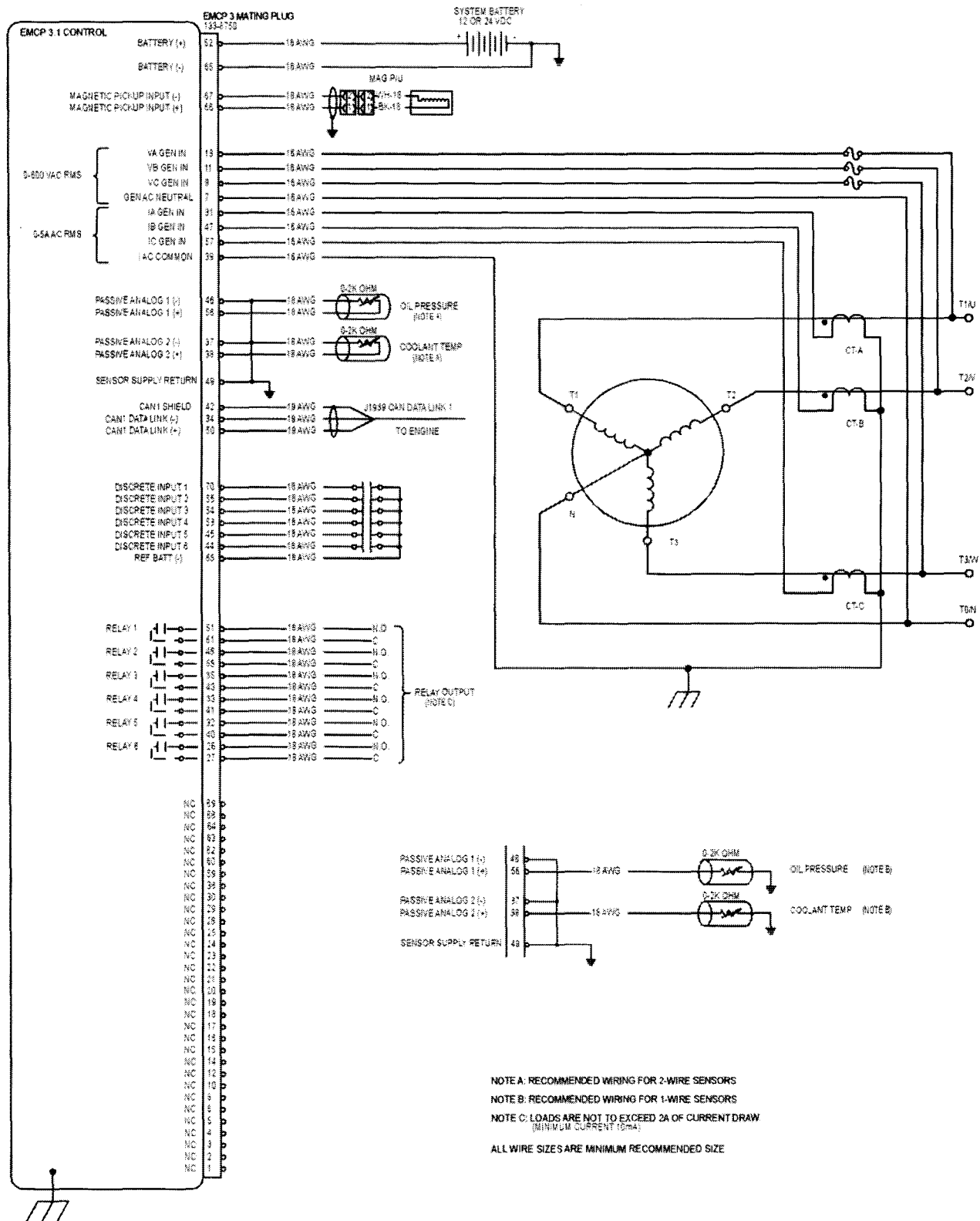

Illustration 28



Electronic Control Module Wiring Diagram - EMCP 3.3

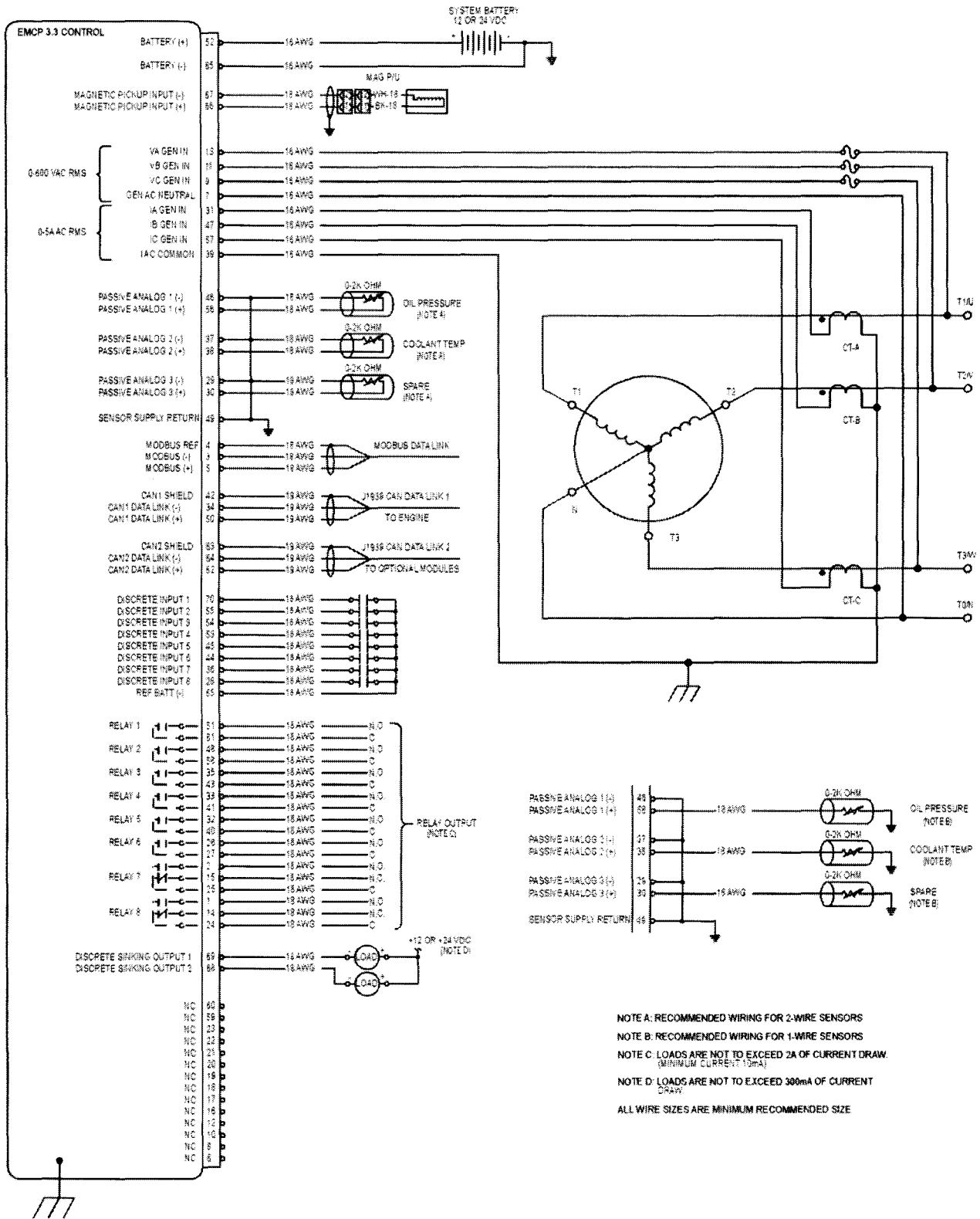

Illustration 30

# Index

## A

Analog Input Circuit Fault .....	89
Annunciator Module .....	48
[ OPTIONAL USE ] .....	48
Adding Additional Remote Annunciator .....	52
Basic Operation .....	49
Configuration .....	49
General Information .....	48

## C

Charging System .....	90
Component Location .....	6

## D

Data Link .....	12
Data Links .....	12
Data Link Circuit Fault .....	92
Diagnostic Capabilities .....	57
The Caterpillar Electronic Technician .....	57
Diagnostic System Procedures .....	69
Diagnostic Trouble Code List .....	58
Digital Input Circuit Fault .....	93
Digital Input Programming .....	24
Digital Inputs .....	24
Function and Navigation Keys .....	25
Programming the Active State of the Digital Input .....	26
Programming the Event Input Functions .....	26
Digital Output Circuit Fault .....	94
Digital Output Programming .....	27
Function and Navigation Keys .....	27
Programming the Active State of the Digital Output .....	28
Programming the Digital Selectors .....	28
Discrete Input/Output Module .....	43
[ OPTIONAL USE ] .....	43
Configuration Behaviors .....	45
General Information .....	43
Inputs .....	43
Outputs .....	44
Specifications .....	45

## E

ECM Connections .....	167
Electrical Connector - Inspect .....	100
Electronic Control Module (Engine) (EUI Engines Only) .....	13
Electronic Control Module (Generator Set) .....	10
ECM Front Panel Components .....	11
General Information .....	10

Electronic Control Module (Generator Set) - Configure .....	106
Function Keys and Navigation Keys .....	106
Initial Setup .....	107
Menu Maps .....	108
Programming the Display Preferences .....	115
Programming The Setpoints .....	116
SETPOINT TABLES .....	116
Setpoints .....	108
Electronic Control Module (Generator Set) - Flash Program .....	106
Electronic Control Module (Generator Set) - Replace .....	105
Replacement Procedure .....	105
Engine Cooldown Warning .....	69
Engine Overcrank Warning .....	69
Engine Overspeed Warning .....	71
Engine Setpoint Verification - Test .....	104
Relevant Engine Parameter Group Setpoints ..	104
Verification Procedures .....	104
Engine Speed Circuit Fault .....	95
Engine Speed Timing Calibration - Setup .....	103
Engine Speed Warning .....	70
Engine Underspeed Warning .....	73
Event Resetting .....	18
Event Viewing .....	17
External Potential Transformer Connections .....	101

## G

General Information .....	4, 55
Generator Control Not in Automatic Warning .....	76
Generator Output Sensing Circuit Fault .....	76
Generator Overcurrent Warning .....	76
Generator Overfrequency Warning .....	77
Generator Overvoltage Warning .....	80
Generator Reverse Power Warning .....	81
Generator Underfrequency Warning .....	83
Generator Undervoltage Warning .....	86

## I

Important Safety Information .....	2
Introduction .....	55

## M

MUI Engine Monitoring and Control .....	14
---	----

**P**

Password Entry ..... 15  
 Change level 1 or level 2 password ..... 17  
 Drop to Minimum Security Level ..... 16  
 Enter Level 1 or 2 Password ..... 16  
 Enter level 3 password ..... 17  
 Function and Navigation Keys ..... 16

**R**

Real Time Clock Programming ..... 38  
 Function and Navigation Keys ..... 38  
 Programming the Time and Date ..... 39  
 Relay Output Programming ..... 31  
 Digital Selector Programming ..... 32  
 Function and Navigation Keys ..... 32  
 Resistive Temperature Device Module ..... 45  
 [ OPTIONAL USE ] ..... 45  
 Configuration Behaviors ..... 47  
 Diagnostics ..... 46  
 General Information ..... 45  
 Module Overview ..... 45  
 Monitoring Features ..... 46  
 Specifications ..... 48

**S**

Service Maintenance Interval Warning ..... 88  
 Service Tools ..... 56  
 Setpoint Programming ..... 20  
 EMCP 3.x Programming Example ..... 21  
 Function and Navigation Keys ..... 20  
 Spare Analog Input Programming ..... 31  
 Configurable Parameters ..... 31  
 Menu Navigation ..... 31  
 Speed Sensor (Engine) - Adjust ..... 103  
 System Operation ..... 14  
 Systems Operation Section ..... 4

**T**

Table of Contents ..... 3  
 Testing and Adjusting ..... 100  
 Testing and Adjusting Section ..... 100  
 Thermocouple Module ..... 39  
 [ OPTIONAL USE ] ..... 39  
 Configuration ..... 42  
 Diagnostics ..... 40  
 General Information ..... 40  
 Monitoring Features ..... 41  
 Specifications ..... 42  
 Troubleshooting Section ..... 55  
 Typical Generator Abbreviations ..... 165

**U**

Unexpected Engine Shutdown ..... 98

**V**

Voltage and Frequency Adjustment ..... 37  
 Adjustment ..... 38  
 Function and Navigation Keys ..... 37

**W**

Wiring Harness (Open Circuit) - Test ..... 100  
 Wiring Harness (Short Circuit) - Test ..... 101