

Operation and Maintenance Manual

G3412C, G3508, G3512, G3516, G3606, G3608, G3612 and G3616 Engines Customer Communication Module

4WD1-Up (Engine)
5JD1-Up (Engine)
8LD1-Up (Engine)
3XF1-Up (Engine)
4WF1-Up (Engine)
1YG1-Up (Engine)
4CG1-Up (Engine)
9TG1-Up (Engine)
7NJ1-Up (Engine)
4EK1-Up (Engine)
6ZM1-Up (Engine)

Important Safety Information

Most accidents that involve product operation, maintenance and repair are caused by failure to observe basic safety rules or precautions. An accident can often be avoided by recognizing potentially hazardous situations before an accident occurs. A person must be alert to potential hazards. This person should also have the necessary training, skills and tools to perform these functions properly.

Improper operation, lubrication, maintenance or repair of this product can be dangerous and could result in injury or death.

Do not operate or perform any lubrication, maintenance or repair on this product, until you have read and understood the operation, lubrication, maintenance and repair information.

Safety precautions and warnings are provided in this manual and on the product. If these hazard warnings are not heeded, bodily injury or death could occur to you or to other persons.

The hazards are identified by the "Safety Alert Symbol" and followed by a "Signal Word" such as "DANGER", "WARNING" or "CAUTION". The Safety Alert "WARNING" label is shown below.



The meaning of this safety alert symbol is as follows:

Attention! Become Alert! Your Safety is Involved.

The message that appears under the warning explains the hazard and can be either written or pictorially presented.

Operations that may cause product damage are identified by "NOTICE" labels on the product and in this publication.

Caterpillar cannot anticipate every possible circumstance that might involve a potential hazard. The warnings in this publication and on the product are, therefore, not all inclusive. If a tool, procedure, work method or operating technique that is not specifically recommended by Caterpillar is used, you must satisfy yourself that it is safe for you and for others. You should also ensure that the product will not be damaged or be made unsafe by the operation, lubrication, maintenance or repair procedures that you choose.

The information, specifications, and illustrations in this publication are on the basis of information that was available at the time that the publication was written. The specifications, torques, pressures, measurements, adjustments, illustrations, and other items can change at any time. These changes can affect the service that is given to the product. Obtain the complete and most current information before you start any job. Caterpillar dealers have the most current information available. For a list of the most current publication form numbers available, see the Service Manual Contents Microfiche, REG1139F.

Table of Contents

Foreword	4
Product Information Section	
Model Views	5
Product Identification Information	6
Reference Materials	7
Operation Section	
Operation	8
Installation	10
Service Information Section	
Troubleshooting	19
Service Information	21
Programming Section	
Protocol	22
Identifiers	24
Examples	38
Index Section	
Index	41

Foreword

Literature Information

This manual should be stored in the operator's compartment in the literature holder or seat back literature storage area.

This manual contains safety information, operation instructions, and maintenance recommendations.

Some photographs or illustrations in this publication show details or attachments that can be different from your machine.

Continuing improvement and advancement of product design might have caused changes to your machine which are not included in this publication. Read, study and keep this manual with the machine.

Whenever a question arises regarding your machine, or this publication, please consult your Caterpillar dealer for the latest available information.

Safety

The safety section lists basic safety precautions. In addition, this section identifies the text and locations of warning signs and labels used on the machine.

Operation

The operation section is a reference for the new operator and a refresher for the experienced operator. This section includes a discussion of gauges, switches, machine controls, attachment controls, and programming information.

Photographs and illustrations guide the operator through correct procedures of checking, starting, operating and stopping the machine.

Operating techniques outlined in this publication are basic. Skill and techniques develop as the operator gains knowledge of the machine and its capabilities.

Maintenance

The maintenance section is a guide to equipment care.

Product Information Section

Model Views

i01253985

Model View Illustrations

SMCS Code: 1926

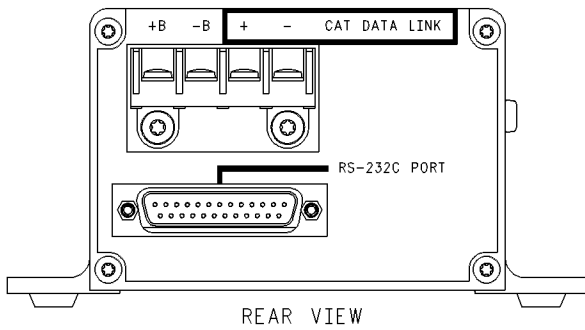

REAR VIEW

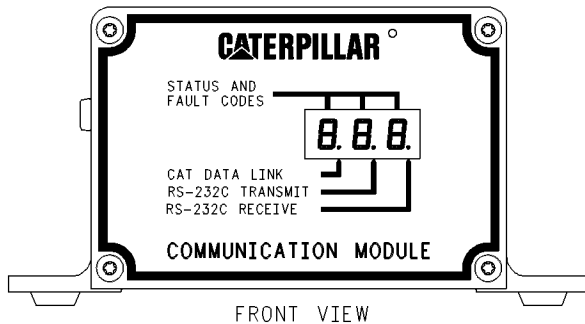

FRONT VIEW

Illustration 1

g00329183

Customer Communication Module (front and rear view)

Product Identification Information

i01201911

Serial Number Location

SMCS Code: 1926

Each CCM has a 5 digit serial number. The serial number will be on the bottom of a flange. The serial number will begin with the letters "SN". The part number is located on the same flange. The part number will be a 7 digit number (XXX-XXXX).

Reference Materials

i01201905

Reference Material

SMCS Code: 1926

Troubleshooting, SENR6510, "G3600 Engine Troubleshooting Guide"

Troubleshooting, SENR6517, "G3500 Air/Fuel Ratio Control Engines Troubleshooting Guide"

Troubleshooting, SENR6413, "G3500 EIS Engine Troubleshooting Guide"

Troubleshooting, SENR6535, "G3408C & G3412C Engines"

Users' Manual, JERD2162, "CCM PC Software Manual"

i01253995

Acronyms

SMCS Code: 1926

ADEM – Advanced Diesel Engine Management

CCM – Customer Communication Module

CID – Component Identifier

<cr> – carriage return

cs – checksum

CTS – Clear To Send

DCD – Data Carrier Detect

DCE – Data Communication Equipment

DTE – Data Terminal Equipment

DTR – Data Terminal Ready

ECM – Engine Control Module

ECS – Engine Control Switch

EIP – Electronic Instrument Panel

EIS – Electronic Ignition System

EMCP – Electronic Modular Control Panel

EMI – Electromagnetic Interference

EPG – Electric Power Generation

ET – Electronic Technician

EUI – Electronic Unit Injector

F – Fuse

FID – Fault Identifier

FMI – Failure Mode Identifier

GSC – Generator Set Control

IID – Instruction Identifier

LSB – Least Significant Byte

MID – Module Identifier

MSB – Most Significant Byte

MUI – Mechanical Unit Injector

PC – Personal Computer

PID – Parameter Identifier

PLC – Programmable Logic Controller

RFI – Radio Frequency Interference

RTS – Request To Send

RX – Data Receive

TX – Data Transmit

Operation Section

Operation

i01201868

General Operation

SMCS Code: 1926

The Customer Communication Module (CCM) provides a communication link between the electronic control system of an engine and a host device. The communication link is established with the CAT Data Link and the industry standard RS-232C. The host device can be one of the following items:

- Personal Computer (PC)
- Programmable Logic Controller (PLC)
- any other device with an RS-232C port

The host device can be connected directly to the CCM. The host device can also be used with a modem.

If the host device is a PC, software that is compatible with the CCM is available from Caterpillar. Refer to "Caterpillar CCM PC For Windows: Getting Started Manual" for more information on the PC software.

The host device will usually be a PLC. The CCM can be used with customized software. A serial data format is used to aid in programming a PLC to communicate with the CCM. Refer to the Operation and Maintenance Manual, SEBU7014, "Communication Protocol for Customized Systems" in the Programming Section of this manual.

i01228437

Display Description

SMCS Code: 1926

The CCM display indicates the status of the CAT Data Link and the RS-232C during normal operation. The CCM will also display some of the current communication parameters.

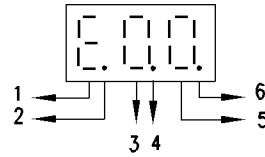

Illustration 2

g00656709

- (1) Error code
- (2) Activity on CAT Data Link
- (3) First digit of error code
- (4) The CCM is transmitting on RS 232C.
- (5) Second digit of error code
- (6) The CCM is receiving data on the RS 232C.

The values E, 0, and 0 indicate an error code of 00. The code E00 means that no faults are present, and the CCM is in normal operating mode. The complete list of error codes are in the Operation and Maintenance Manual, SEBU7014, "Diagnostic Code - Troubleshoot" under the Service Information section. The periods on the display will flash when information is transmitted on the CAT Data Link. The periods on the display will flash when information is transmitted on the RS-232C port. No period indicates that no activity is taking place.

Note: Units with the part number 117-6170 will display the faults that have been logged. Each fault will be displayed for 2 seconds in 60 second intervals. This flashing fault log will not appear for any other version of CCM. The fault log can be cleared by using the PC software for the CCM.

CCM Power Up Display

The CCM display will perform a lamp test (8.8.8.) during the power up sequence. The parameters for communication protocol (n81 9600 E00) will then be displayed. An example of the power up sequence is given below:

Table 1

8.8.8. n81 9600 E00	
8.8.8.	All of the segments are turned on for a two second lamp test.
n 8 1 n 8 1	No parity (default value) Eight data bits (default value) One stop bit (default value)
9600	Rate of Communication (default value)
E00	Error Code No faults are present.

The values for communication can be changed by using a host device or by using the PC software for the CCM. Refer to "Caterpillar CCM PC For Windows: Getting Started Manual". These communication values must match the values for the modems (if used) and the values for the host device.

Installation

i01201862

General Installation Requirements

SMCS Code: 1926

When a CCM is installed, the following specifications must be met:

- environmental
- mounting
- wire and cable

The connection diagrams must be followed. Improper wiring may cause erratic operation of the CCM. If modems are used, the user must set up the modems properly.

i01229410

Specifications

SMCS Code: 1926

Environmental

- The ambient operating temperature range is from -40° to 70°C (-40° to 158°F).
- The storage temperature is from -40° to 85°C (-40° to 185°F).
- The unit must be protected from direct contact with liquids. If sealing of the unit is required, the CCM must be in a water tight enclosure.
- The CCM weighs 0.75 kg (1.65 lb).

Mounting

The total length of all CAT Data Link wiring must be no longer than 30.5 m (100 ft). Cat Data Link wiring that is connected to a service tool and all permanent wiring are included in the restriction on length.

Note: Do not mount the CCM on the engine or within the engine mounted instrument panel. The CCM is not designed for direct engine mounting. The CCM must be mounted on shock mounts.

Internal Battery

The CCM contains a battery that supplies power for internal memory whenever the CCM is turned off. Refer to the Operation and Maintenance Manual, SEBU7014, "Battery - Replace" under the Service Information section of this manual.

Power Supply

- The requirements for battery voltage are 15 to 45 volts DC (24 or 32 volt DC nominal power).
- The +/-B power dissipation is approximately 3.0 watts at 24 volts.
- The current drawn by the CCM at 12 volts is 0.11 amps and the current drawn by the CCM at 36 volts is 0.13 amps .

Dimensions

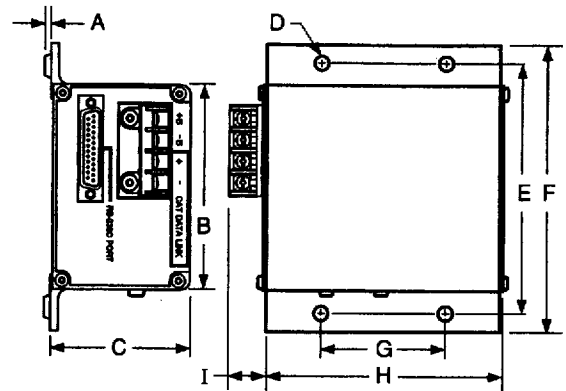

Illustration 3

g00647099

i01229477

Table 2

CCM MOUNTING DIMENSIONS	
Item	Dimension
A	3.5 mm (0.14 in)
B	106.5 mm (4.19 in)
C	73.0 mm (2.87 in)
D	7.5 mm (0.29 in) diameter
E	130 mm (5.12 in)
F	149.0 mm (5.87 in)
G	66.2 mm (2.61 in)
H	125.5 mm (4.94 in)
I	17.8 mm (.70 in)

General Specifications for Wire and Cable

SMCS Code: 1926

The following specifications for wire and for cable are given to lower drops in voltage over long runs of wire. The specifications will also help minimize EMI/RFI interference.

- The wires that are connected to + B and – B on the CCM must be at least 16 AWG.
- The maximum length of the CAT Data Link is 30.5 m (100 ft).
- The maximum length for the RS-232C cable is 15 m (50 ft).

Note: In order to conform to the European Economic Community (EEC) 336 Directive, the RS-232C cable must be shielded.

No terminations and no splices are allowed on the above wires, except as noted in Illustration 4. The cable that is connected to the (+/-) CAT Data Link must be a 16 AWG shielded twisted pair cable. Use 123-2376 Electrical Cable.

Table 3

CAT DATA LINK CABLE SPECIFICATIONS, RESISTANCE AND CAPACITANCE			
	Measured Parameter		
	C to C ⁽¹⁾	C to S ⁽²⁾	SCSR ⁽³⁾
Nominal Capacitance per meter (foot)	75 pF (23 pF)	144 pF (44 pF)	-
Nominal Resistance per meter (foot) at 20°C (68°F)	-	-	14.0 mΩ (4.27 mΩ)

(1) Conductor to Conductor

(2) Conductor to Shield

(3) Single Conductor Series Resistance (16 AWG, 19/29 stranding)

i01206092

General Wiring Diagram

SMCS Code: 1926

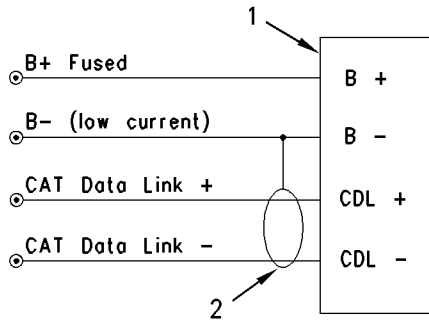

Illustration 4

g00645132

Wiring Connections for the CCM

- (1) CCM
- (2) Shield

Note: The shield (2) should not be connected to the CCM (1).

Note: Terminals for the customer are located on the bottom right side of the G3600 ESS panel. Refer to the master schematic for the site for additional information.

Note: The + battery connection to the CCM must be switched with the power to the engine control panel. The CCM should power ON with the control panel and the CCM should power OFF with the control panel.

i01267694

RS-232C Cable Requirements

SMCS Code: 1926

The CCM is classified as Data Terminal Equipment (DTE) for RS-232C communication.

- The CCM RS-232C connector is a standard 25 pin D shell connector with pins.
- The RS-232C cable must be shielded.
- When the CCM is connected to other DTE devices a Null Modem cable or an adapter is required. A personal computer is an example of a DTE device.

- When the CCM is connected to Data Communication Equipment (DCE) a Null Modem cable or an adapter is not required. Modems, printers, and terminals are examples of DCE devices.

- The DCD pin on the CCM must be asserted in order to allow the CCM to communicate. If the DCD pin is deasserted, the CCM will shut down all outgoing information. Once the DCD pin is reasserted, the message must be reactivated. IID 11 and IID 82 must be used to reactivate the message.

A 25 to 25 pin cable and a Null Modem adapter are needed if the CCM is directly connected to a PC with a 25 pin RS-232C connector. Refer to Illustration 5.

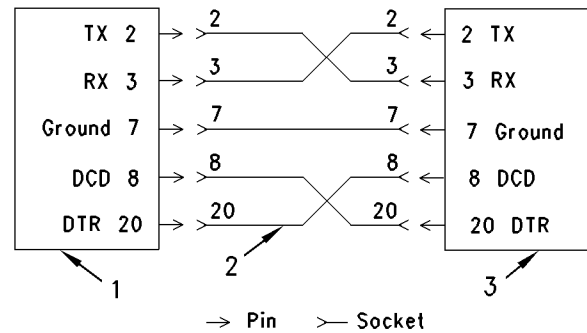

Illustration 5

g00645220

CCM Cable requirements for Direct Connection to PC with 25 Pin Connector

- (1) PC with 25 pin RS-232C connector
- (2) 25 to 25 pin null modem cable
- (3) CCM with 25 pin RS-232C connector

If the PC has a 9 pin RS-232C connector a 9 to 25 pin cable with a Null Modem adapter is required. Refer to Illustration 6.

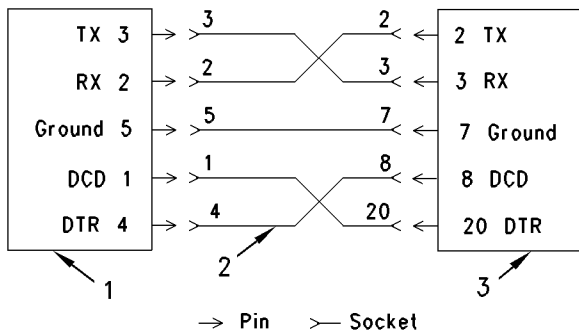

Illustration 6 g00645245

CCM Cable Requirements for Direct Connection to PC with 9-Pin Connector

- (1) PC with 9 pin RS-232C connector
- (2) 9 to 25 pin null modem cable (132-0453)
- (3) CCM with 25 pin RS-232C connector

The Null Modem adapter connects the Data Transmit of one device to the Data Receive of the other device. The Null Modem adapter connects the Data Carrier Detect and the Data Terminal Ready pins in a similar manner. Cables are available from most personal computer suppliers.

Note: Verify that the cables and Null Modem adapters are compatible with the specifications in Table 4.

Table 4

RS-232C PIN DEFINITIONS	
Pin Number	Description
2	Data Transmit (TX)
3	Data Receive (RX)
7	Ground
8	Data Carrier Detect (DCD)
20	Data Terminal Ready (DTR)

A 25 to 25 pin cable or a 9 to 25 pin cable is needed when the CCM is used with a modem. Refer to Illustrations 7 and 8. The type of cable will depend on the number of pins on the RS-232C connector of the PC.

Note: Do not use a Null Modem adapter to connect a modem to the PC or the CCM.

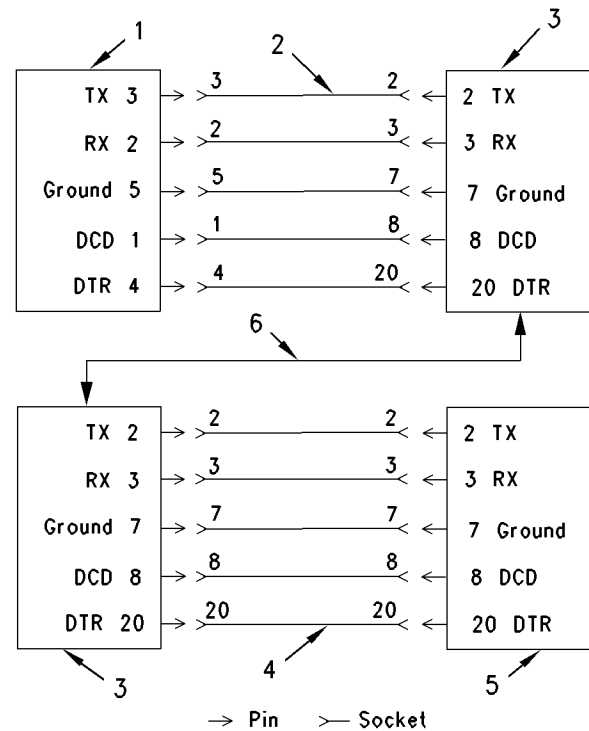

Illustration 7 g00645279

CCM Cable Requirements for Modem Connection to PC with 9-Pin Connector

- (1) PC with 9 pin RS-232C connector
- (2) 9 to 25 pin cable
- (3) Modems that are connected by telephone lines
- (4) 25 to 25 pin cable
- (5) CCM with 25 pin RS-232C connector
- (6) Telephone line

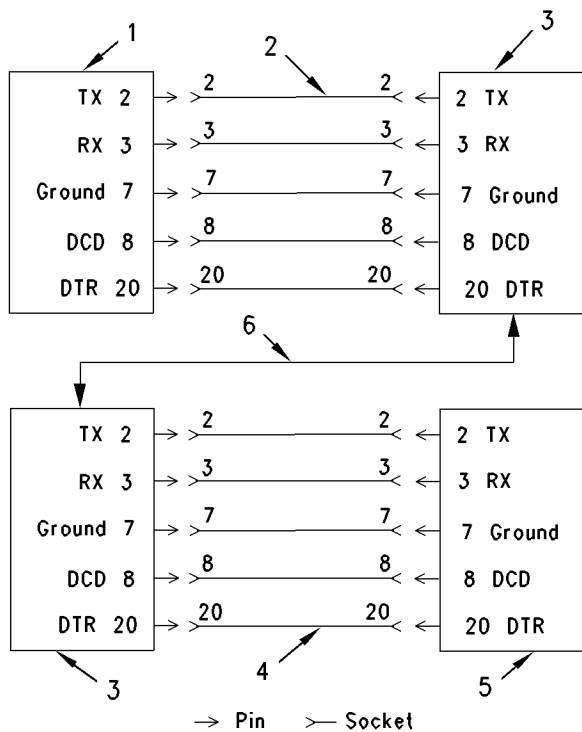

Illustration 8 g00645341

CCM Cable Requirements for Modem Connection to PC with 25-Pin Connector

- (1) PC with 25 pin RS-232C connector
- (2) 25 to 25 pin cable
- (3) Modems that are connected by telephone lines
- (4) 25 to 25 pin cable
- (5) CCM with 25 pin RS-232C connector
- (6) Telephone line

i01200873

Communication Initialization

SMCS Code: 1926

The CCM may be connected directly to the host equipment. The CCM may also be connected to the equipment by using modems. The initialization procedure depends on the type of connection. The correct initialization procedure is necessary for proper communication between the CCM and the equipment.

When modems are installed between the CCM and the host equipment, the complexity of the communication network is increased. The RS-232C ports must be set to the proper parameters for communication on the following equipment: host equipment, modems, and CCM. The phone line ports of the modems must be compatible. To connect the modems, consult the manufacturer's instructions.

Initialization for Direct Connection

SMCS Code: 1926

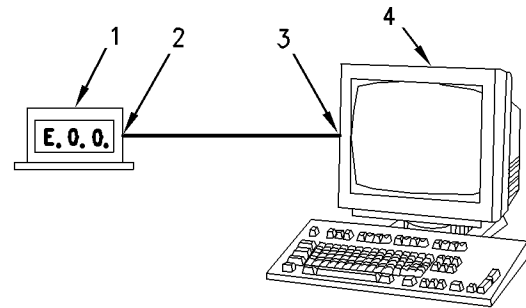

Illustration 9

g00669441

CCM to Host Equipment Direct Connection

- (1) CCM
- (2) CCM RS-232C port
- (3) Computer RS-232C port
- (4) Host equipment

Make sure that the following equipment is available:

- A personal computer. Refer to "Caterpillar CCM PC For Windows: Getting Started Manual" for specifications on the PC.
- The proper RS-232C cables are required for the particular installation. Refer to the Operation and Maintenance Manual, SEBU7014, "RS-232C Cable Requirements" in the Operation Section of this manual.
- The PC software for the CCM is optional. The PC software for the CCM is recommended for troubleshooting assistance.

Procedure

Perform the following procedure to initialize communication with the host equipment that is connected directly to the CCM.

Note: The host equipment and the CCM should be turned OFF before you change the cables to the serial ports.

1. The CCM should be installed with all of the wiring. Refer to Operations and Maintenance Manual, SEBU7014, "General Specifications for Wire and Cable" in the Operation Section of this manual.

i01201579

2. Determine the parameters for communication for the installation. The default rate of communication (bits per second or bps) is 9600. The remaining default settings from the factory are no parity, 8 data bits, and 1 stop bit. These parameters will work well in most installations. Use the Operations and Maintenance Manual, SEBU7014, "Communication Parameters - Identify" under Service Information in this manual to determine the communication parameters that are stored in the CCM.
3. If the PC software for the CCM is not used, go to step 6. If the PC software for the CCM is used, refer to the "Caterpillar CCM PC For Windows: Getting Started Manual" and go to step 4.
4. Proceed to the CCM configuration screen in the Utilities menu. Set the parameters for communication to match the values that were chosen in step 2.
5. Use the CCM configuration screen to set the Connection Type to Direct Connection. Proceed with Step 7.
6. Program the parameters for communication on the CCM, using IID 24 and parameter F601 by using a communications device. Set the Connection Type (bit 1) to Direct Connection by using IID 24 with parameter AA12.
7. Cycle the power to the CCM in order to verify that the parameters for communication are set correctly.

Initialization for Remote Connection with Modem

SMCS Code: 1926

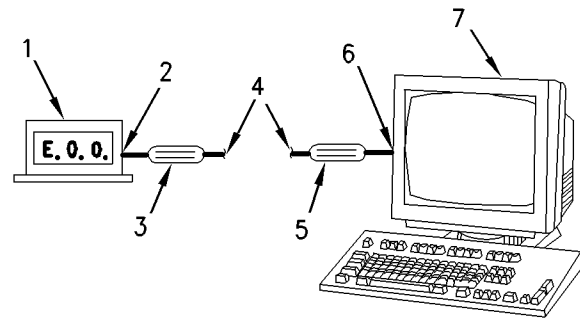

Illustration 10

g00669454

CCM/Host equipment Remote Connection with Modems

- (1) CCM
- (2) CCM RS-232C port
- (3) Answering modem
- (4) Telephone line
- (5) Originating modem
- (6) Computer's RS-232C port
- (7) Host equipment

You should verify the CCM is operating correctly before attempting a remote connection via modem. Verifying correct operation can be accomplished by following the instructions in Operations and Maintenance Manual, SEBU7014, "Initialization for Direct Connection" under the Operation Section in this manual. The user can verify proper operation of the CCM at the location. The user can also become familiar with the CCM.

Perform the following procedure in order to initialize communication between the host equipment, the modems, and the CCM. Make sure that the following equipment is available:

- A personal computer with a terminal emulator software program Refer to "Caterpillar CCM PC For Windows: Getting Started Manual" for specifications on the PC. The user is responsible for understanding the operation of the PC.
- The proper RS-232C cables are required for the particular installation. A RS-232C cable must be temporarily connected from the PC to the Answering Modem. Refer to the Operation and Maintenance Manual, SEBU7014, "RS-232C Cable Requirements" in the Operation Section of this manual.

- The two modems must support the Hayes AT command set. This is necessary for both the Answering Modem and the Originating Modem.
- The CCM PC For Windows software is optional. The PC software for the CCM is recommended for troubleshooting assistance.

Note: Some personal computers will have an internal modem. The internal modem may be used as the Originating Modem. The internal modem must be compatible with the Answering Modem. Consult the instructions for the two modems.

Perform the following procedure in order to initialize communication with the CCM and the Answering Modem. The Originating Modem is set up later by the PC software or remote host equipment. The user is responsible for understanding the remote device and modems.

Note: In the following steps, the PC and the modems should be turned OFF before you change the cables on the serial ports. When power is reapplied, the modem must be powered up first.

1. The CCM should be installed with all of the wiring. Refer to the Operations and Maintenance Manual, SEBU7014, "General Wiring Diagram" and "General Specifications for Wire and Cable" in this manual.
2. Determine the communication parameters for the installation. The default rate of communication (bits per second or bps) is 9600. The remaining default settings from the factory are no parity, 8 data bits, and 1 stop bit. These parameters will work well in most installations. Use the Operation and Maintenance Manual, SEBU7014, "Communication Parameters - Identify" in this manual to determine the parameters of communication that are stored in the CCM.

Note: The RS-232C serial port communication baud rate is often referred to as the DTE speed. The phone port communication rate is often referred to as the DCE speed.

3. Connect the RS-232C port of the Answering Modem directly to the RS-232C port of the PC. This connection is temporary. This connection is required to set up the Answering Modem.
4. Use the terminal emulator on the PC to set communication parameters for the RS-232C port. Use the values that were chosen in step 2.

Note: The symbol Ø indicates the number zero.

5. Several commands must be sent to the Answering Modem that set the parameters for communication to the proper values. The examples are Hayes AT commands. Actual command sets vary widely between modem manufacturers. Consult the manual for the modem.

Table 5

Typical Answering Modem Setup Commands			
Item	Explanation	Command Example	Command for User's Modem
a	Set the modem to the factory defaults. This is important if the setup of the modem is unknown.	AT&F	
b	Set to communicate in error control and in asynchronous mode. NOTE: If the modem does not support this command, enter the AT command for error control. Set to communicate in asynchronous mode with a separate command (Item c). Otherwise go to Step d.	AT&Q5	
c	Set to communicate in asynchronous mode. Note: If the &Q5 command is supported, the modem is already in asynchronous mode, and this command should not be sent.	AT&Q0	
d	Set Auto answer to ON. This tells the modem to answer the phone line after the first ring. If left at 0, the modem will never answer an incoming call. The value of this register can be seen with the ATSD? command.	ATSD=1	
e	Set Flow Control to XON/XOFF. This turns off RTS/CTS hardware handshaking between the modem and CCM since the CCM does not have RTS or CTS lines. It turns on the XON/XOFF software handshaking.	AT&K4	
f	Set DCD to track status of carrier detect signal. This causes the DCD line from the modem to follow the state of the phone line carrier. When the call to the CCM's modem has been made and the modem to modem handshaking is done, the DCD line will change and allow the CCM to receive data. Note: This is very important. If the DCD line is not at the right state, the CCM cannot receive data.	AT&C1	
g	Set DTR to monitor DTR signal and hang up and reset modem on an on-to-off DTR transition. This causes the modem to hang up and reset if the CCM drops the DTR line.	AT&D3	
h	Result codes do not have to be returned. Or, if the result codes are returned, the codes must be in originate mode, but not in answer mode.	ATQ2	
i	Set DTR transition response delay to maximum value less than 10 seconds. This example would cause the modem to hang up the line 2.5 seconds after the DTR line from the CCM changes. Note: Refer to your particular manual. Some modems specify the time in 1/100th of a seconds, and some in 1/10th of a second.	ATS25=250	
j	Set delay before forced hang-up to maximum value less than 3 seconds.	ATS38=2	
k	Write the setup parameters into memory 0. When the setup parameter are written, any that were not changed are stored into the memory.	AT&W0	
l	Set to recall memory 0 on reset.	AT&Y0	
m	View the modem active profile. This is an optional command that allows the user to view the above parameters stored in the modem. The profile should be written down and saved for future reference.	AT&V	

6. The setup for the Answering Modem is now complete. Disconnect the PC from the Answering Modem. Temporarily connect the PC directly to the CCM. Refer to the Operation and Maintenance Manual, SEBU7014, "RS-232C Cable Requirements" in this manual.

7. If PC software for the CCM is not used, go to step 10. If the PC software for the CCM is used, refer to "Caterpillar CCM PC For Windows: Getting Started Manual" for instructions on using the software and continue with the next step.

8. Go to the CCM configuration screen in the Utilities menu. Set the communication parameters to match the values that were chosen in Step 2.

- 9.** Use the CCM configuration screen to set the Connection Type. Set the Connection Type to “Modem”. Proceed to Step 11.
- 10.** Set the parameters for communication on the CCM, using IID 24 and parameter F601. Set the Communications Type (bit 1) to the Modem, using IID 24 and parameter AA12.
- 11.** Turn off the power to the CCM and to the Modem. Disconnect the PC from the CCM. Connect the PC, the modems, and the CCM. Refer to Operation and Maintenance Manual, SEBU7014, “RS-232C Cable Requirements” in this manual.
- 12.** Ensure that the CCM and the Answering Modem are connected before power is applied to the CCM or the Modem. Apply power to the Modem first. Once the modem has powered up, apply power to the CCM. Ensure that the CCM remains on for a minimum of 30 seconds. The CCM will set the speed of the Answering Modem to match the CCM.

Service Information Section

Troubleshooting

i01254279

System - Troubleshoot

SMCS Code: 1926

This section will aid in solving problems that are NOT accompanied by an error code on the CCM.

Table 6

Additional Troubleshooting		
Problem	Possible Explanation	Required Action
Direct Connections		
Host equipment unable to connect to CCM	Host equipment is configured improperly, or a cabling error is present.	Determine if the proper serial port on the host equipment has been selected. Make sure the correct RS-232C cable is being used.
Modem Connections		
Host equipment unable to connect to CCM	Host equipment configured improperly, modem not set up properly, or cabling error is present.	Determine if proper serial port on the host equipment is selected. Make sure that the Communication Specifications are being met and consult the modem manual. Make sure the correct RS-232C cable is being used.
Modem does not answer	Improper modem configuration.	Verify that the modem is configured per the instructions given in the Communication Initialization section in this manual.

i01254273

Diagnostic Code - Troubleshoot

SMCS Code: 1926

The CCM has internal troubleshooting to aid in solving various system problems.

Table 7

CCM Error Codes		
CCM Error Code	Explanation	Action Required
E00 (all bits zero)	No fault, normal operating mode	None
E01 (bit 1 set)	Setpoint fault	CCM passwords or communication setups are corrupted. Reprogram from Connection and Setup pull-down menus.
E02 (bit 2 set)	M50 message error	Check customer generated M50 code
E03 (bit 3 set)	Memory backup battery is weak	Change battery. Refer to Operation and Maintenance Manual, SEBU7014, "Battery - Replace" in this manual.
E04 (bit 4 set)	RS-232C link short circuit fault	Check RS-232C cable, PC port, and CCM port
E05 (bit 5 set)	Internal buffer overflow on RS-232C or Data Link fault	Possibly caused by a slower than acceptable communication rate from the RS-232C port or an open CAT Data Link connection during RS-232C transmission. Increase communication rate and check CAT Data Link wires.
E06 (bit 6 set)	Invalid CAT Data Link Message fault	Caused by: 1. Too much traffic on CAT Data Link. 2. CAT Data Link wires too long.
E07 (bit 7 set)	Miscellaneous CAT Data Link Fault	Caused by: 1. (+/-) CAT Data Link shorted to (+/-) battery. 2. Internal hardware fault in CCM. Check CAT Data Link wiring and then replace CCM if wiring is good.
E08 (bit 8 set)	RS-232C link message fault (parity, data size)	Check RS-232C protocol (communication rate, data bits, stop bits, parity) of CCM and host equipment.
E.. (bits 16-9)	-	Set to zero (0). Reserved for future use.

Service Information

i01224433

Communication Parameters - Identify

SMCS Code: 1926

The parameters for communication (rate of communication, parity, number of data bits, and number of stop bits) are stored in non-volatile memory within the CCM. To read the parameters for communication, follow these steps:

1. Power down the CCM by removing the wire that is connected to the +B terminal.
2. Power up the CCM by reconnecting the wire to the +B terminal. The display on the CCM will perform a lamp test (8.8.8.). The CCM will then display the communication protocol parameters (n81 9600 E00) that have been previously programmed.

Table 8

8.8.8. n81 9600 E00	
8.8.8.	All segments are turned on for a two second lamp test.
n81 n 8 1	No parity (default value) Eight data bits (default value) One stop bit (default value)
9600	Rate of Communication (default value)
E00	Error code for no fault codes in memory

These parameters can be programmed to different values. Refer to "Setup Screen in the Caterpillar CCM PC For Windows: Getting Started Manual".

i01224427

Battery - Replace

SMCS Code: 1926

The CCM contains a 101-1785 Battery that supplies power for internal memory whenever the CCM is powered down. The battery has an expected life of five years.

The battery is mounted to the front plate of the CCM behind the display. To replace the battery, follow these steps:

1. Disconnect power to the CCM.

2. Remove the four screws that secure the front plate to the housing.
3. The battery is held in place by two small tabs. A tie wrap provides additional support.
 - a. Remove the tie wrap.
 - b. Use a small screwdriver to carefully pry one tab and lift that side of the battery slightly.
 - c. Repeat for the other tab and remove the battery.
4. The battery has one corner that is angled. This corner will ensure that the battery is oriented correctly for installation.
 - a. Carefully install the new battery into the holder.
 - b. Verify that the battery pins are entering the sockets of the holder properly. Insert the battery until the tabs are holding the battery.
 - c. Install the new tie wrap.
5. Install the front plate of the CCM.

Programming Section

Protocol

i01201846

Communication Protocol for Customized Systems

SMCS Code: 1926

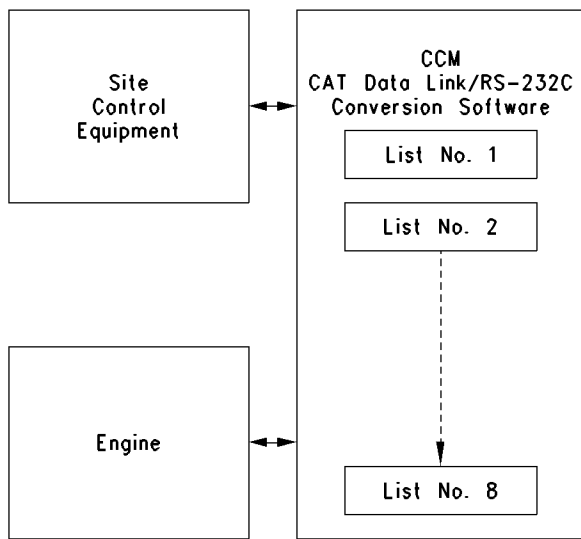

Illustration 11 g00645777
 Communication overview of the CCM

The CCM communicates with the host equipment via a standard RS-232C serial data link. The serial data link uses the M50 protocol to transfer data. The M50 commands allow the user to periodically request a broadcast of multiple engine parameters. The broadcast is used by host equipment for monitoring. Single parameter read commands and write commands allow the user to control the engine from the host device.

The host equipment can create a maximum of eight lists. The lists are stored in non-volatile memory in the CCM. These lists contain multiple engine parameters that are broadcast to the host device from the CCM through the RS-232C network. The engine parameters are given a unique parameter identifier (PID). Refer to the Operation and Maintenance Manual, SEBU7014, "Parameter Identifiers for General Usage" under the Programming Section of this manual. The CCM provides the communication link between the host device and the engine.

The M50 protocol command messages that are transmitted to the CCM must be ASCII format. The response to the command messages will always be returned in ASCII format. The responses to the broadcast can be sent in ASCII. The responses to the broadcast can also be sent in binary. The format of the response is determined by the particular Instruction Identifier (IID) that is being used.

The command messages contain an Instruction Identifier (IID). All command messages and responses will have the following standard preamble.

50xyyzz (IID specific data)

xx is the module identifier of the sending module.

Table 9

XX	Module
00	Customer device
61	CCM

yy is the Instruction Identifier.

Table 10

yy	IID Description
10	Broadcast Response, program using IID 13
11	Activate a Broadcast List.
12	Deactivate a Broadcast List.
13	Program a Broadcast List.
15	Status Response to IID 11, 12, 13, and 82
24	Single Parameter Read Request
25	Response to IID 24
34	Single Parameter Write Request
35	Response to IID 34.
82	Request to Broadcast Diagnostic Codes

zz is the number of bytes in the message after this byte. zz does not include the checksum. This value will change depending on the data that is associated with the IID.

Calculation for the Checksum

The checksum is an important part of the M50 message. By using the checksum, the integrity of the message is determined. The checksum is a 2's complement value of the summation of all the data bytes in the message. The message is a good message if all the bytes and the checksum add to zero (0).

The following message is an example.

5000358131C9

The checksum for this message is C9. Although the message is sent in ASCII, the checksum must be calculated by using the hexadecimal values.

Table 11

Byte	ASCII Value	Hexadecimal Value
\$50	\$35 \$30	\$50
\$00	\$30 \$30	\$00
\$35	\$33 \$35	\$35
\$81	\$38 \$31	\$81
\$31	\$33 \$31	\$31
Total		\$xx37
Mask		\$0037
2's Complement		\$C9
Total		\$00

The value of the checksum is calculated by using only the hexadecimal values of the data bytes. The x's in the first total indicate numbers that should be disregarded. The checksum in this case is \$C9.

Note: Numbers that are preceded by \$ are in hexadecimal form.

i01201891

Password - Enable and Disable

SMCS Code: 1926

The password protection for the CCM on Gas Engines is initially disabled. Password protection may be necessary for some applications. Changing the password protection can be done with the PC software for the CCM. The password protection can also be changed by using a host device to write the IIDs.

Enabling Passwords

The AA12 and the F012 PIDs must be used in order to enable the password protection.

Note: Refer to the Operation and Maintenance Manual, SEBU7014, "Parameter Identifiers for General Usage" in this manual.

1. Use IID 34 with a unit number of 61. Write to PID AA12 to clear bit 3. The message format will be **500034050061AA1200cs**.

This message will enable passwords and baud rate changes. This message will also set the CCM for direct connect. If the last two items need to be set the other way, bits 1 and 2 should be set to a 1.

Note: Refer to the AA12 description in Operation and Maintenance Manual, SEBU7014, "Parameter Identifiers for General Usage" in this manual.

2. In order to enable the changes, the power to the CCM must be cycled or the security level must be written to zero. The security level is written to zero by using IID 34. The message will be **500034050061F01200cs**.

Note: When the passwords were disabled, each character was set to a blank or space. You should set the level 3 password on the CCM to something else.

Disabling Passwords

To disable the passwords, the AA12 and AA8A PIDs must be used.

Note: Refer to the Operation and Maintenance Manual, SEBU7014, "Parameter Identifiers for General Usage" in this manual.

1. Use IID 34 with a unit number of 61. Write to PID AA8A with the level 3 password. This will set the security level in the CCM to level 3. The message will be **5000340C0061AA8Ab1b2b3b4b5b6b7b8cs**. The example above shows that b1 through b8 are the ASCII characters of the password. If the password is all spaces, simply end the message after PID AA8A. Do not include any of the data bytes. The CCM will automatically add spaces when a character is not present.
2. Use IID 34 with a unit number of 61. Write PID AA12 with bit 3 set. This will disable the password protection. The message will be **500034050061AA1204cs**. This message will disable the passwords. Baud rate changes will be enabled. The CCM will be set for a direct connection. If the last two items need to be set the other way, you should set bits 1 and 2 to 1.

Note: When the passwords are disabled, all three passwords are set to all blanks (spaces).

Identifiers

i01201870

Instruction Identifiers

SMCS Code: 1926

General IID Information

Depending on the application, the unit number may vary. If the unit number is not correct for the application, there will be no data in the broadcast response messages. The following table shows the unit numbers for the applications that are supported.

Table 12

Application	Unit Number
G3600	13
G3500 Air/Fuel Ratio	12
G3400 EIS & G3500 EIS	ØE

Although the CCM can handle a broadcast of all lists in 0.5 seconds, the data will not be refreshed as fast. If the total number of parameters (excluding combustion probe parameters) exceeds 16, then a more reasonable update rate would be one second.

The CCM stores all information in non-volatile memory. This means the CCM needs to be programmed only once. After that, each time the power is applied, the CCM will start sending data at the desired time intervals as previously programmed.

All command messages must be terminated with a carriage return after the checksum. In this manual the carriage return will be shown as follows: <cr>. The <cr> is a hexadecimal ØD and is NOT converted to ASCII.

IID 10 - Broadcast Response

This IID is used to broadcast data. The CCM will send this message if the time to broadcast data has elapsed. In order to send an IID 10 message, ALL of the parameters must be present on the CAT data link. This means that if there are eight parameters requested and only seven are present on the CAT data link, the IID 10 message will not be sent. When IID 10 is used, the data will be two bytes in length. If a parameter only has one data byte, zeros will be added in front of the data.

An example of the IID 10 message is: **5061101B0113,ddd1,ddd2,ddd3,ddd4,ddd5,ddd6,ddd7,ddd8,cs<cr>**.

Table 13

IID 10 - Broadcast Response	
Byte(s)	Description
1-4	Standard preamble (50 xxyyzz)
5	Parameter List Number \$01 - \$08 show which list 1 through 8 is being sent.
6	Unit Number 13 for G3600 ESS system 12 for G3500 Air/Fuel Ratio system ØE for EIS system
7	Separator
8,9	1st PID
10	Separator
11, 12	2nd PID
13	Separator
14, 15	3rd PID
16	Separator
17, 18	4th PID
19	Separator
20, 21	5th PID
22	Separator
23, 24	6th PID
25	Separator
26, 27	7th PID
28	Separator
29, 30	8th PID
31	Separator
32	Checksum of message

A separator can be a comma, space, or none. A separator is NOT converted to ASCII.

IID 11 - Activate a Broadcast List

This IID is used in order to activate a broadcast list that has been programmed. When a list is programmed into the CCM, the list is set to be deactivated. The list will stay deactivated until a valid IID 11 message is received. After receiving an IID 11 message, the CCM responds with an IID 15 message. The IID 15 message is for verification of the IID 11 message. If the IID 11 message is valid and the list is programmed, broadcasting of the data will start. Lists can be activated and deactivated at any time without being reprogrammed.

A typical IID 11 example is: **5000110101cs**.

Table 14

IID 11- Activate a Broadcast List	
Byte(s)	Description
1-4	Standard preamble (50 xxyzz)
5	Parameter List Number \$01 - \$08 show which list 1 through 8 is being sent.
6	Checksum of message

IID 12 - Deactivate a Broadcast List

This IID is used in order to deactivate a broadcast list that has been programmed. A list will stay activated until a valid IID 12 message is received. Upon receiving a IID 12 message, the CCM responds with a IID 15 message. This is used to indicate the validity of the message. If the IID 12 message is valid, the broadcasting of the data will stop. Lists can be activated and deactivated at any time without being reprogrammed.

A typical IID 12 example is: **5000120101cs**.

Table 15

IID 12 - Deactivate a Broadcast List	
Byte(s)	Description
1-4	Standard preamble (50 xxyzz)
5	Parameter List Number \$01 - \$08 show which list 1 through 8 is being sent.
6	Checksum of message

IID 13 - Create a Broadcast List

This IID is used in order to program a broadcast list. After receiving an IID 13 command message, the CCM responds with an IID 15 message. If the command message is valid, the list will be programmed in the CCM. This IID has several different flags that need to be decided upon at the time of programming.

Request Time

This time is used to tell the CCM the time interval at which a particular list should be sent. The maximum time is 127.5 seconds in 0.5 second intervals.

Programming Flags

Available programming options include the following:

- Response Format - ASCII or BINARY

- Message Terminators - (CR) or (CR+LF)
(CR) = Carriage Return
(LF) = Line Feed

- Data Separator - comma, space, or none.

Parameters

The message must contain eight parameters. Even if the number of desired parameters is only four, the remaining four parameters must be filled with zeros (0). The broadcast response (IID 10) will only contain data for the nonzero parameters.

A typical IID 13 example is:

**500013150113010000ddd1ddd2ddd3ddd4
ddd5ddd6ddd7ddd8cs**

Table 16

IID 13 - Create a Broadcast List	
Byte(s)	Description
1-4	Standard preamble (50 xxyyzz)
5	Parameter List Number \$01 - \$08 shows which list 1 through 8 is being programmed.
6	Unit Number 13 for G3600 ESS system 12 for G3500 Air/Fuel Ratio system ØE for EIS system
7	Time (between list or parameters) Resolution: 0.5 second per bit Data range: 0 to 127.5 (\$00 to \$FF)
8, 9	Programming flags Bit 1 0 = ASCII 1 = Binary Bit 3, 2 00 = Message terminated by carriage return 01 = Message terminated by carriage return and line feed Bit 4 0 = Always Bit 6, 5 00 = Comma separator 01 = Space separator 10 = No separator Bit 7-16 Reserved for future use
10, 11	1st PID ⁽¹⁾
12, 13	2nd PID ⁽¹⁾
14, 15	3rd PID ⁽¹⁾
16, 17	4th PID ⁽¹⁾
18, 19	5th PID ⁽¹⁾
20, 21	6th PID ⁽¹⁾
22, 23	7th PID ⁽¹⁾
24, 25	8th PID ⁽¹⁾
26	Checksum of message

⁽¹⁾ Data must be entered for all PIDs. If a PID is not used, 0000 must be entered for that PID.

IID 15 - Status Reply to IID 11, IID 12, IID 13, and IID 82

This IID is used to indicate the validity of a command message that was just sent to the CCM.

A typical IID 15 example is: **506115021300cs**.

Table 17

IID 15 - Status Reply to IID 11, IID 12, IID 13, and IID 82	
Byte(s)	Description
1-4	Standard preamble (50 xxyyzz)
5	IID sent in response to (11, 12, 13, or 82)
6	Status Reply \$00 = IID data is OK \$10 = Invalid list number (greater than 8 or less than 1) \$20 = List is not programmed \$30 = Faulty checksum or command format
7	Checksum of message

IID 24 - Single Parameter Read Request

This IID is used to request data for an individual parameter. The parameter can be sent one time per second. Another IID 24 request cannot be sent until one second has elapsed and/or an IID 25 message has been received for the previous request. The CCM must be connected to the CAT data link when this IID is used.

A typical IID 24 example is: **500024040013F515cs**

Table 18

IID 24 - Single Parameter Read Request	
Byte(s)	Description
1-4	Standard preamble (50 xxyyzz)
5	Reply format \$00 = ASCII \$01 = Binary
6	Unit Number 13 for G3600 ESS system 12 for G3500 Air/Fuel Ratio system ØE for the EIS system 61 for the CCM
7, 8	PID
9	Checksum of message

IID 25 - Single Parameter Read Response

This IID is used to indicate a response to a single parameter read request (IID 24). The number of bytes for this IID will vary. The number of bytes is dependent on the parameter that was requested. If the CAT data link is not connected to the CCM, this IID will not be sent.

A typical IID 25 example is:
5061250513F515ddddcs

Note: In this example, parameter F515 has two data bytes.

Table 19

IID 25 - Single Parameter Read Response	
Byte(s)	Description
1-4	Standard preamble (50 xxyzz)
5	Unit Number 13 for G3600 ESS system 12 for G3500 Air/Fuel Ratio system ØE for the EIS system 61 for the CCM
6, 7	PID
8, 9	Data value of requested parameter. Data value may be from 1 through 27 bytes. This example shows two bytes.
10	Checksum of message

IID 34 - Single Parameter Write Request

This IID is used to write data for an individual parameter. The data can be sent one time per second. Another IID 34 request cannot be sent until one second has elapsed and/or an IID 35 message has been received for the previous request. The CCM must be connected to the CAT data link when this IID is used.

A typical IID 34 example is:
500034060013F515ddddcs

Note: In this example, parameter F515 has two data bytes.

Table 20

IID 34 - Single Parameter Write Request	
Byte(s)	Description
1-4	Standard preamble (50 xxyzz)
5	Reply format \$00 = ASCII \$01 = Binary
6	Unit Number 13 for G3600 ESS system 12 for G3500 Air/Fuel Ratio system ØE for the EIS system 61 for the CCM
7, 8	PID
9, 10	Data value of requested parameter. Data value may be from 1 through 27 bytes. This example shows two bytes.
11	Checksum of message

IID 35 - Single Parameter Write Response

This IID is used to indicate a response to a single parameter write request (IID 34). The number of bytes for this IID will vary depending on the parameter that was written. If the CAT data link is not connected to the CCM, this IID will not be sent.

A typical IID 35 example is:
5061350513F515ddddcs

Note: In this example, parameter F515 has two data bytes.

Table 21

IID 35 - Single Parameter Write Response	
Byte(s)	Description
1-4	Standard preamble (50 xxyzz)
5	Unit Number 13 for G3600 ESS system 12 for G3500 Air/Fuel Ratio system ØE for the EIS system 61 for the CCM
6, 7	PID
8, 9	Data value of requested parameter. Data value may be from 1 through 27 bytes. This example shows two bytes.
10	Checksum of message

IID 82 - Request to Broadcast Diagnostic Codes

This IID is used to activate and de-activate the broadcasting of diagnostic codes. If the CAT data link is not connected to the CCM, this IID will not be sent. Upon receiving an IID 82 message, the CCM responds with an IID 15 message. If the command message was valid, then the diagnostic codes will be sent at the desired time interval. The diagnostic codes are sent in a packed format in the order of activation. The diagnostic codes are in the troubleshooting guide.

Table 22

IID 82 - Request to Broadcast Diagnostic Codes	
Byte(s)	Description
1-4	Standard preamble (50 xxyyzz)
5	Unit Number 13 for G3600 ESS system 12 for G3500 Air/Fuel Ratio system 0E for the EIS system 61 for the CCM
6	Time between diagnostic code update. One bit is five seconds (2 = 10 seconds)
7	Format Bit 1 0 = ASCII 1 = Binary Bit 2-7 Reserved for future use Bit 8 0 = Activate the broadcast 1 = Deactivate the broadcast
8	Checksum of message

IID 82 example

User sends the following message to request broadcast of the diagnostic codes from the G3600 ESS system (unit number 13):

50008203130100cs<cr>

CCM sends:

506115028200cs<cr>

If a diagnostic code exists, the CCM sends the following message:

506182nn13xxx1y1xxx2y2cs<cr>

nn = number of bytes

xxx1 = CID for diagnostic code 1

y1 = FMI for diagnostic code 1

xxx2 = CID for diagnostic code 2

y2 = FMI for diagnostic code 2

A maximum of 9 codes can be present.

If a 501-09 diagnostic code exists, the CCM sends the following message:

506182041301F509cs<cr>

diagnostic code 1

CID = 01F5 = 501

FMI = 09 = 09

code = 501-09

If no diagnostic code exists, CCM sends the following message:

506182021300cs<cr>

Refer to the Engine Troubleshooting Guide for the meaning of the diagnostic codes.

Note: The diagnostic codes can also be retrieved by using IID 24 and PID 0082.

i01201882

Parameter Identifiers for General Usage

SMCS Code: 1926

Each Parameter Identifier (PID) is two bytes in length. The Parameter Identifier is hexadecimal. The PID is followed by one or two data bytes. The data bytes are represented as aa for one data byte or aabb for two data bytes, or mb for multiple bytes.

The following chart is a quick reference list of the Parameter Identifiers (PID). The chart also contains a brief description of the Parameter Identifiers.

Table 23

QUICK REFERENCE CHART WITH DESCRIPTION OF GENERAL PARAMETER IDENTIFIERS	
PID	Description
\$AA12 aa	CCM Auxilliary Functions Used to read or program functions on the CCM.
\$AA87 cccccccc	Access Level 1 Password Used to read or program the Level 1 Password.
\$AA88 cccccccc	Access Level 2 Password Used to read or program the Level 2 Password.
\$AA89 cccccccc	Access Level 3 Password Used to read or program the Level 3 Password.
\$AA8A cccccccc	Login Password Password used to login when host device is connecting to the CCM.
\$F012 aa	Security Access Level Used to read the password level.
\$F601 aabb	CCM RS-232C Serial Port Configuration Used to program the RS-232C port configuration on the CCM.

CCM Auxiliary Functions
\$AA12 aa

Used to read or program function on the CCM.

Table 24

(aa)	Bits 8-5	Reserved for future use
	Bit 4	0 = CCM unit number is set to 61 1 = CCM unit number is set to 66 Reserved for Caterpillar. DO NOT USE!
	Bit 3	0 = Enable password protection 1 = Disable password protection
	Bit 2	0 = Enable baud rate change 1 = Disable baud rate change
	Bit 1	0 = Direct connection 1 = Modem connection

Access Level 1 Password
\$AA87 ccccccc

Used to read or program the Level 1 Password.

Table 25

(cccccccc)	Bits 64-1 (cccccccc) Level 1 password in printable ASCII form. Must be at least 6, but no more than 8 characters long. Do not pad with spaces if the password is less than 8 characters long. Use only letters and numbers for the password characters.
------------	--

Access Level 2 Password
\$AA88 ccccccc

Used to read or program the Level 2 Password.

Table 26

(cccccccc)	Bits 64-1 (cccccccc) Level 2 password in printable ASCII form. Must be at least 6, but no more than 8 characters long. Do not pad with spaces if the password is less than 8 characters long. Use only letters and numbers for the password characters
------------	---

Access Level 3 Password
\$AA89 ccccccc

Used to read or program the Level 3 Password.

Table 27

(cccccccc)	Bits 64-1 (cccccccc) Level 3 password in printable ASCII form. Must be at least 6, but no more than 8 characters long. Do not pad with spaces if the password is less than 8 characters long. Use only letters and numbers for the password characters
------------	---

Login Password
\$AA8A ccccccc

Password used to login when host device is connecting to the CCM.

Table 28

(cccccccc)	Bits 64-1 (cccccccc) Login password in printable ASCII form. Must be at least 6, but no more than 8 characters long. Do not pad with spaces if the password is less than 8 characters long. Use only letters and numbers for the password characters
------------	---

Note: If the password is all spaces, do not enter any data after the PID. The CCM will automatically add the necessary spaces. When used to login, using IID 34, the CCM responds with PID F012 to indicate which security level password was matched.

Security Access Level
\$F012 aa

Used to read the password level.

Table 29

(aa)	\$00 = Security level 00 \$01 = Security level 01 \$02 = Security level 02 \$03 = Security level 03
------	--

**CCM RS-232C Serial Port Configuration
 \$F601 aabb**

Used to program RS-232C port configurations on the CCM.

Table 30

(aa)	Bits 16-15	Not used
	Bit 14	0 = 1 stop bit 2 = 2 stop bits
	Bit 13	0 = No echo 1 = Echo enabled
	Bit 12-9	0100 = 300 baud 0101 = 600 baud 0110 = 1200 baud 1000 = 2400 baud 1010 = 4800 baud 1100 = 9600 baud 1101 = 19200 baud
(bb)	Bit 8	Not used
	Bit 7-6	10 = 7 data bits 11 = 8 data bits
	Bit 5-3	000 = No parity 001 = Odd parity 011 = Even parity
	Bit 2-1	Not used

i01201783

Parameter Identifiers for G3600 Engines

SMCS Code: 1926

Each Parameter Identifier (PID) is two bytes in length. The PID is hexadecimal. The PID is followed by one or two data bytes. The data bytes are represented as "aa" for one data byte, "aabb" for two data bytes, or "mb" for multiple bytes.

Table 31

G3600 Parameter Identifiers (PID)				
PID	Description	Resolution/Data	Data Range	Length
0003 aa	Detonation Level	00 - 09 = 1 bar 10 - 12 = 2 bars 13 - 15 = 3 bars 16 - 17 = 4 bars 18 = 5 bars 19 - 20 = 6 bars 21 = 7 bars 22 - 26 = 8 bars 27 - 31 = 9 bars 32 - 255 = 10 bars	0 to 255	Bits 8 - 1 (aa)
000D aa	Remote Fault Reset	\$FF = reset all diagnostic codes		Bits 8 - 1 (aa)
0040 aabb	Engine RPM	0.5 rpm per bit	0 to 16383.5 rpm	Bits 16 - 9 (aa) Bits 8 - 1 (bb)
0041 aabb	Engine Timing	0.1 degrees per bit	0 to 40 degrees	Bits 16 - 9 (aa) Bits 8 - 1 (bb)
0044 aabb	Engine Coolant Temperature	1 °C per bit	-40 to 120 °C	Bits 16 - 9 (aa) Bits 8 - 1 (bb)
0046 aabb	Desired Speed	0.5 rpm per bit	0 to 3200 rpm	Bits 16 - 9 (aa) Bits 8 - 1 (bb)
0047 aabb	Desired Timing	0.1 degrees per bit	0 to 40 degrees	Bits 16 - 9 (aa) Bits 8 - 1 (bb)
0054 aabb	Engine Oil Pressure Gauge	0.5 kPa per bit	0 to 600 kPa	Bits 16 - 9 (aa) Bits 8 - 1 (bb)
0082 mb	Diagnostic Codes	aabbcc... aabb - CID cc - FMI Refer to IID 82		0 - 27 bytes
F013 aa	System Battery Voltage	0.5 volts per bit	0.0 to 127.5 volts	Bits 16 - 9 (aa) Bits 8 - 1 (bb)
F111 aa	Fuel Actuator Command	1 % per bit	0 to 100%	Bits 8 - 1 (aa)
F112 aa	Status	Idle/Rated	0 = idle 1 = rated	Bit 8
		Grid Status	0 = off grid 1 = on grid	Bit 7
		Run Status	00 = running 01 = coasting 10 = shutdown 11 = not used	Bits 6-5
F115 aa	Fuel Correction Factor	1 % per bit	0 to 255%	Bits 8 - 1 (aa)
F116 aa	Wastegate Actuator Command	1 % per bit	0 to 100%	Bits 8 - 1 (aa)
F117 aa	Choke Actuator Command	1 % per bit	0 to 100%	Bits 8 - 1 (aa)
F118 aa	Indicated Load	1 % per bit	0 to 100%	Bits 8 - 1 (aa)

(continued)

(Table 31, contd)

G3600 Parameter Identifiers (PID)				
PID	Description	Resolution/Data	Data Range	Length
F119 aa	Status	Mode Control Switch	11 = Start 10 = Auto 01 = Stop 00 = Off/Reset	Bit 8-7
		E-Stop	1 = Stop 0 = Run	Bit 6
		Driven Equipment	1 = Ready 0 = Not Ready	Bit 5
		Prelube Slave Relay	1 = On 0 = Off	Bit 4
		Prelube Relay	1 = On 0 = Off	Bit 3
		Prelube Switch	1 = Not Ready 0 = Ready	Bit 2
		Initiate Contact	1 = Stop 0 = Run	Bit 1
F40E aabb	Differential Oil Pressure	0.5 kPa per bit	0 to 400 kPa	Bits 16-9 (aa) Bits 8-1 (bb)
F509 aabb	Crankcase Pressure	0.1 kPa per bit	-10 to 10 kPa	Bits 16-9 (aa) Bits 8-1 (bb)
F511 aabb	Air Temperature	0.1 °C per bit	-40 to 120 °C	Bits 16-9 (aa) Bits 8-1 (bb)
F512 aabb	Air-to-Fuel Ratio	0.1 volumetric air-to-fuel ratio per bit	0 to 60	Bits 16-9 (aa) Bits 8-1 (bb)
F517 aabb	Desired Combustion Probe	0.01 ms per bit	0 to 25 ms	Bits 16-9 (aa) Bits 8-1 (bb)
F518 aabb	Fuel Flow	1.0 SCFM per bit	0 to 3000 SCFM	Bits 16-9 (aa) Bits 8-1 (bb)
F519 aabb	Actual Fuel Pressure	0.1 kPa per bit	0 to 120 kPa	Bits 16-9 (aa) Bits 8-1 (bb)
F51A aabb	BTU Potentiometer Setting	1.0 BTU per bit	0 to 2300 BTU	Bits 16-9 (aa) Bits 8-1 (bb)
F51B aabb	Actual Air Pressure	0.1 kPa per bit	0 to 350 kPa	Bits 16-9 (aa) Bits 8-1 (bb)
F51C aabb	Desired Air Pressure	0.1 kPa per bit	0 to 400 kPa	Bits 16-9 (aa) Bits 8-1 (bb)
F51D aabb	Actual Fuel Temperature	0.1 °C per bit	-40 to 120 °C	Bits 16-9 (aa) Bits 8-1 (bb)
F51E aabb	Air Flow	1.0 SCFM per bit	0 to 7000 SCFM	Bits 16-9 (aa) Bits 8-1 (bb)
F51F aabb	Right Air Restriction	0.1 kPa per bit	0 to 20 kPa	Bits 16-9 (aa) Bits 8-1 (bb)
F520 aabb	Left Air Restriction	0.1 kPa per bit	0 to 20 kPa	Bits 16-9 (aa) Bits 8-1 (bb)

(continued)

(Table 31, contd)

G3600 Parameter Identifiers (PID)				
PID	Description	Resolution/Data	Data Range	Length
	Combustion Probe Burn Time	0.01 ms per bit	0 to 25 ms	Bits 16-9 (aa) Bits 8-1 (b)
F701 aabb	Cylinder #1			
F702 aabb	Cylinder #2			
F703 aabb	Cylinder #3			
F704 aabb	Cylinder #4			
F705 aabb	Cylinder #5			
F706 aabb	Cylinder #6			
F707 aabb	Cylinder #7			
F708 aabb	Cylinder #8			
F709 aabb	Cylinder #9			
F70A aabb	Cylinder #10			
F70B aabb	Cylinder #11			
F70C aabb	Cylinder #12			
F70D aabb	Cylinder #13			
F70E aabb	Cylinder #14			
F70F aabb	Cylinder #15			
F710 aabb	Cylinder #16			
F711 aabb	Average Combustion Probe Burn Time	0.01 ms per bit	0 to 25 ms	Bits 16-9 (aa) Bits 8-1 (bb)

i01201641

Parameter Identifiers for G3400 EIS and G3500 EIS

SMCS Code: 1926

Each Parameter Identifier (PID) is two bytes in length. The PID is hexadecimal. The PID is followed by one or two data bytes. The data bytes are represented as "aa" for one data byte, "aabb" for two data bytes, or "mb" for multiple bytes.

Table 32

G3400 EIS and G3500 EIS Parameter Identifiers				
PID	Description	Resolution/Data	Data Range	Length
0002 aa	Speed/Timing MAP	1 MAP per bit	0 to 255	Bits 8 - 1 (aa)
0003 aa	Detonation	00 - 09 = 1 bar 10 - 12 = 2 bars 13 - 15 = 3 bars 16 - 17 = 4 bars 18 = 5 bars 19 - 20 = 6 bars 21 = 7 bars 22 - 26 = 8 bars 27 - 31 = 9 bars 32 - 255 = 10 bars	0 to 255	Bits 8 - 1 (aa)
0007 aa	Number of Detonation Sensors	1 sensor per bit	0 to 8	Bits 8 - 1 (aa)
0008 aa	Engine Type	High Nibble = family Low Nibble = # cyls. i.e. 5 = 3500 family F = 16 cyls. 5F = 3516 Engine	0 to 255	Bits 8 - 1 (aa)
000D aa	Remote Fault Reset	\$FF = reset all diagnostic codes		Bits 8 - 1 (aa)
0040 aabb	Engine RPM	0.5 rpm per bit	0 to 16383.5 rpm	Bits 16-9 (aa) Bits 8 - 1 (bb)
0041 aabb	Engine Timing	0.1 degrees per bit	0 to 40 degrees	Bits 16 - 9 (aa) Bits 8 - 1 (bb)
0047 aabb	Desired Engine Timing	1 degree per bit	0 to 40 degrees	Bits 16 - 9 (aa) Bits 8 - 1 (bb)
005D aabb	Intake Manifold Pressure	1 kPa per bit		Bits 16 - 9 (aa) Bits 8 - 1 (bb)
0082 mb	Diagnostic Codes	aabbcc. . . aabb - CID cc - FMI Refer to IID 82		0 - 27 Bytes
0086 mb	Software Date Code	aa aa aa = month bb bb = year 53 45 50 = S E P 39 35 = 9 5		5 Bytes
F123 aa	Load/Timing MAP	1 MAP per bit	0 to 255	Bits 8 - 1 (aa)

i01201715

Parameter Identifiers for G3500 Air/Fuel Ratio

SMCS Code: 1926

Each Parameter Identifier (PID) is two bytes in length. The PID is hexadecimal. The PID is followed by one or two data bytes. The data bytes are represented as “aa” for one data byte, “aabb” for two data bytes, or “mb” for multiple bytes.

Table 33

G3500 A/F Ratio Parameter Identifiers (PID)				
PID	Description	Resolution/Data	Data Range	Length
0001 aa	# Of Speed Sensitive Timing Maps Available	1 map per bit	0 to 6	Bits 8 - 1 (aa)
0002 aa	Speed Sensitive Timing Map in Use	0 = disabled 1 = map #1 enabled 2 = map #2 enabled, etc.	0 to 6	Bits 8 - 1 (aa)
0003 aa	Detonation	00 - 09 = 1 bar 10 - 12 = 2 bars 13 - 15 = 3 bars 16 - 17 = 4 bars 18 = 5 bars 19 - 20 = 6 bars 21 = 7 bars 22 - 26 = 8 bars 27 - 31 = 9 bars 32 - 255 = 10 bars	0 to 255	Bits 8 - 1 (aa)
0007 aa	# of Detonation Sensors	0 = no sensors 1 = 1 sensor, etc.	0 to 2	Bits 8-1 (aa)
0008 aa	Engine Type	High Nibble = family Low Nibble = # cyls. i.e. 5 = 3500 family F = 16 cyls. 5F = 3516 Engine	0 to 255	Bits 8 - 1 (aa)
000C aa	Oxygen Sensor Status	bit 8 1 = start cal. bit 7 1 = cal. in progress bit 6 1 = sensor on (status) bit 5 1 = command sensor on	0 to F0	Bits 8 - 1 (aa)
0011 aa	Ignition Timing Calibration	bit 8 1 = cal. good bit 8 0 = cal. bad bit 7 1 = enable cal. bit 7 0 = disable cal.	0 to C0	Bits 8-1 (aa)
0016 aa	Inlet Manifold Temp	1 degree C per bit	0 to 255	Bits 8 - 1 (aa)
0040 aabb	Actual Engine RPM	0.5 rpm per bit	0 to 16383 rpm	Bits 16-9 (aa) Bits 8-1 (bb)
0041 aabb	Actual Ignition Timing	0.1 degree per bit	0 to 400 0 to 40 degrees	Bits 16-9 (aa) Bits 8-1 (bb)
0046 aabb	Desired Engine Speed	0.5 rpm per bit	0 to 6400 0 to 3200 rpm	Bits 16-9 (aa) Bits 8-1 (bb)
0047 aabb	Desired Ignition Timing	0.1 degree per bit	0 to 400 0 to 40 degrees	Bits 16-9 (aa) Bits 8-1 (bb)
004B aabb	Rated Engine Speed	0.5 rpm per bit	0 to 32767 rpm	Bits 16-9 (aa) Bits 8-1 (bb)
005D aabb	Inlet Manifold Pressure	1 kPa per bit	0 to 6383 kPa	Bits 16-9 (aa) Bits 8-1 (bb)
0080 mb	Device ID Code	12,00,01,00,61,00 12,00 = MID 01,00 = Software Version 61,00 = Application Type		6 Bytes
0082 mb	Diagnostic Codes	aabbcc... aabb CID cc - FMI Refer to IID 82		0 - 27 Bytes

(continued)

(Table 33, contd)

G3500 A/F Ratio Parameter Identifiers (PID)				
PID	Description	Resolution/Data	Data Range	Length
0086 mb	Software Date Code	aa aa aa = month bb bb = year i.e. 53 45 50 = S E P 39 35 = 9 5		5 Bytes
F108 aa	Speed Governor Aux. #1 Proportional Gain Adjustment	1 unit per bit (signed)	-30 to +30	Bits 8 - 1 (aa)
F109 aa	Speed Governor Aux. #1 Internal Gain Adjustment	1 unit per bit (signed)	-30 to +30	Bits 8 - 1 (aa)
F10A aa	Speed Governor Aux. #1 Derivative Gain Adjustment	1 unit per bit (signed)	-30 to +30	Bits 8 - 1 (aa)
F10B aa	Speed Governor Primary Proportional Gain Adjustment	1 unit per bit (signed)	-30 to +30	Bits 8 - 1 (aa)
F10C aa	Speed Governor Primary Integral Gain Adjustment	1 unit per bit (signed)	-30 to +30	Bits 8 - 1 (aa)
F10D aa	Speed Governor Primary Derivative Gain Adjustment	1 unit per bit (signed)	-30 to +30	Bits 8 - 1 (aa)
F113 aa	Engine Operation	bit 8 0 = genset bit 8 1 = industrial bit 6 0 = isochronous governor bit 6 1 = droop governor		Bits 8 - 1 (aa)
F11B aa	Engine Compression Ratio	0.1:1 ratio per bit	0:1 to 22.3:1	Bits 8 - 1 (aa)
F11C aa	Air/Fuel Ratio Control Proportional Gain Adjustment Factor	1 unit per bit	-30 to +30	Bits 8 - 1 (aa)
F11D aa	Air/Fuel Ratio Control Integral Gain Adjustment Factor	1 unit per bit	-30 to +30	Bits 8 - 1 (aa)
F121 aa	EIS Mode	bit 8 1 = master bit 8 2 = slave		Bits 8 - 1 (aa)
F122 aa	# of Load Sensitive Ignition Timing Maps Available	1 = 1 map 2 = 2 maps, etc. 0 = disabled	0 to 2	Bits 8 - 1 (aa)
F123 aa	Load Sensitive Timing Map in Use	1 = # 1 2 = # 2 0 = disable	0 to 2	Bits 8 - 1 (aa)
F124 aa	EIS Special Test Status	bit 8, 1 = enable special test bit 8, 0 = disable bits 5-1, 0 = test passed bits 5-1, non zero = # of tests failed		Bits 8 - 1 (aa)
F125 aa	Air/Fuel Ratio Enable/Disable Flag	0 = enable A/F ratio nonzero = disable A/F ratio		Bits 8 - 1 (aa)
F129 aa	Speed Governor Aux #1 Gain Status	0 = aux. #1 governor gains not in use nonzero = aux. #1 governor gains in use		Bits 8 - 1 (aa)

(continued)

(Table 33, contd)

G3500 A/F Ratio Parameter Identifiers (PID)				
PID	Description	Resolution/Data	Data Range	Length
F44E aabb	Actual Exhaust Oxygen Percent	0.01% oxygen per bit	0 to 655.03%	Bits 16-9 (aa) Bits 8-1 (bb)
F44F aabb	Desired Exhaust Oxygen Percent	0.01% oxygen per bit	0 to 655.03%	Bits 16-9 (aa) Bits 8-1 (bb)
F45B aabb	Desired Engine Ramp Rate	speed per sec. per bit	0 to 65535	Bits 16-9 (aa) Bits 8-1 (bb)
F510 aabb	Desired Engine Idle Speed	0.5 rpm per bit	0 to 32767 rpm	Bits 16-9 (aa) Bits 8-1 (bb)
F515 aabb	Engine Speed Drop Percent	0.1 % per bit	0 to 6550%	Bits 16-9 (aa) Bits 8-1 (bb)
F524 aabb	Desired Full Load Exhaust Oxygen	0.01% oxygen per bit	0 to 100%	Bits 16-9 (aa) Bits 8-1 (bb)

Examples

i01201903

Programming Examples for M50 Protocol

SMCS Code: 1926

In the following examples, the symbol “<-” indicates messages that are sent by the host device. The symbol “->” indicates messages that are sent by the CCM. The first two examples show the programming of broadcast messages. The third example activates the diagnostic codes.

Note: The values in these examples are hexadecimal.

G3600 ESS Programming Examples

Message 1

This example will obtain the following information from a G3600 ESS system.

- Engine Speed
- Engine Timing
- Fuel Position
- Data will be sent in 0.5 second intervals from the CCM to the host equipment.
- Data will be separated by commas.

1. Program the following message:
**<-50001315011301000000400041F111
00000000000000000000cs
->506115021300cs**

2. Activate the message:
**<-5000110101cs
->506115021100cs**

Message 2

This example will obtain the following information from a G3600 ESS system.

- Fuel Flow
- Air Flow
- BTU reading
- Air Temperature

- Data will be sent in one second intervals from the CCM to the host device.
- Data will not have any separators.

1. Program the following message:
**<-500013150213020020F518F51EF51AF511
000000000000000000cs
->506115021300cs**

2. Activate the message:
**<-5000110102cs
->506115021100cs**

Message 3

This example will obtain the diagnostic codes from the G3600 ESS system in 5 second intervals.

1. Send the following message:
**<-50008203130100cs
->506115028200cs**
2. The messages will come from the CCM in the following format.
**->5061100C0113,ddd1,ddd2,ddd3,cs
->5061100C0113,ddd1,ddd2,ddd3,cs
->5061100A0213ddd1ddd2ddd3ddd4cs
->5061100C0113,ddd1,ddd2,ddd3,cs
->5061100C0113,ddd1,ddd2,ddd3,cs
->5061100A0213ddd1ddd2ddd3ddd4cs
->5061100C0113,ddd1,ddd2,ddd3,cs
->5061100C0113,ddd1,ddd2,ddd3,cs
->5061100A0213ddd1ddd2ddd3ddd4cs
->5061100C0113,ddd1,ddd2,ddd3,cs
->5061100C0113,ddd1,ddd2,ddd3,cs
->5061100A0213ddd1ddd2ddd3ddd4cs
->5061100C0113,ddd1,ddd2,ddd3,cs
->5061100C0113,ddd1,ddd2,ddd3,cs
->5061100A0213ddd1ddd2ddd3ddd4cs
->5061820301F40Ccs**

This pattern will then repeat.

Shutting Off The Messages

To turn off the messages, the following messages must be sent. The messages can be sent at any time.

Turn OFF Message 1
**<-5000120101cs
->506115021200cs**

Turn OFF Message 2
**<-5000120102cs
->506115021200cs**

Turn OFF Message 3 (diagnostic codes)
 <-50008203130180cs
 ->506115028200cs

Diagnostic Codes - Retrieve

The CCM allows the diagnostic codes to be read from the CCM and the Gas Engine Controller. This is accomplished by using IID 82 or IID 24.

Requesting Diagnostic Codes for the CCM

Use IID 24 with PID 0082 to retrieve the codes for the CCM. The format for the message is given below.

5000240400610082cs

The CCM responds with two data bytes. Each E code on the display represents a bit in the two bytes of data. Refer to Operation and Maintenance Manual, SEBU7014, "Diagnostic Code - Troubleshoot" in this manual.

Requesting Diagnostic Codes for the G3600

The diagnostic codes for the G3600 can be retrieved by using IID 82 or IID 24 with PID 0082. The diagnostic codes will be sent on the RS-232C link at the specified time when IID 82 is used. Refer to the IID 82 description in Operation and Maintenance Manual, "Communication Protocol for Customized Systems" in this manual. The format for the IID 82 message is given below.

50008203130100cs

The diagnostic codes will be sent in five second intervals. The second method uses IID 24 with PID 0082. The diagnostic codes will be displayed once every time the message is sent. The format for the IID 24 message is given below:

5000240400130082cs

Refer to the PID 0082 format in Operation and Maintenance Manual, SEBU7014, "Parameter Identifiers for G3600 Engines" and the IID 24 format in Operation and Maintenance Manual, SEBU7014, "Instruction Identifiers".

Requesting Diagnostic Codes for the G3500 Air/Fuel Ratio

The diagnostic codes for the G3500 Air/Fuel Ratio can be retrieved by using IID 82. The diagnostic codes for the G3500 Air/Fuel Ratio can also be retrieved by using IID 24 with PID 0082. The diagnostic codes will be sent on the RS-232C link at the specified time when IID 82 is used. Refer to IID 82 in the Operation and Maintenance Manual, SEBU7014, "Communication Protocol for Customized Systems" in this manual. The format for the IID 82 is given below:

50008203120100cs

The diagnostic codes will be sent in five second intervals. The second method uses IID 24 with PID 0082. The diagnostic codes will be displayed once every time the message is sent. The format for the IID 24 message is given below:

5000240400120082cs

Refer to the PID 0082 format in the Operation and Maintenance Manual, SEBU7014, "Parameter Identifiers for G3500 Air/Fuel Ratio" in this manual. Also refer to the IID 24 format in the Operation and Maintenance Manual, SEBU7014, "Instruction Identifiers" in this manual for the diagnostic format.

Requesting the Diagnostic Codes for the EIS

The diagnostic codes for the EIS can be retrieved by using IID 82 or IID 24 with PID 0082. The diagnostic codes will be sent on the RS-232C link at the specified time when IID 82 is used. Refer to IID 82 in Operation and Maintenance Manual, SEBU7014, "Communication Protocol for Customized Systems" in this manual. The format for the IID 82 message is given below:

500082030E0100cs

The diagnostic codes will be sent in five second intervals. The second method uses IID 24 with PID 0082. The diagnostic codes will be displayed once every time the message is sent. The format for the IID 24 message is given below:

50002404000E0082cs

The diagnostic codes will be in reverse order if both of the conditions that follow exist.

- The EIS control is a 3E-0257, 121-9631, 111-5946, or 124-4565.
- The date code that is displayed on the "DDT screen 00 press ALT 2" is prior to FEB 95.

Index

A	
Acronyms.....	7
B	
Battery - Replace.....	21
C	
Communication Initialization.....	14
Communication Parameters - Identify	21
Communication Protocol for Customized Systems.....	22
Calculation for the Checksum	22
D	
Diagnostic Code - Troubleshoot	19
Display Description.....	8
CCM Power Up Display.....	8
E	
Examples.....	38
F	
Foreword.....	4
Literature Information.....	4
Maintenance	4
Operation	4
Safety.....	4
G	
General Installation Requirements	10
General Operation	8
General Specifications for Wire and Cable.....	11
General Wiring Diagram.....	12
I	
Identifiers.....	24
Important Safety Information	2
Initialization for Direct Connection	14
Initialization for Remote Connection with Modem..	15
Installation	10
Instruction Identifiers	24
IID 10 - Broadcast Response.....	24
IID 11 - Activate a Broadcast List.....	24
IID 12 - Deactivate a Broadcast List	25
IID 13 - Create a Broadcast List.....	25
IID 15 - Status Reply to IID 11, IID 12, IID 13, and IID 82.....	26
IID 24 - Single Parameter Read Request.....	26
IID 25 - Single Parameter Read Response.....	26
IID 34 - Single Parameter Write Request	27
IID 35 - Single Parameter Write Response.....	27
IID 82 - Request to Broadcast Diagnostic Codes.....	27
M	
Model View Illustrations.....	5
Model Views	5
O	
Operation.....	8
Operation Section.....	8
P	
Parameter Identifiers for G3400 EIS and G3500 EIS.....	33
Parameter Identifiers for G3500 Air/Fuel Ratio.....	34
Parameter Identifiers for G3600 Engines	30
Parameter Identifiers for General Usage	28
Password - Enable and Disable.....	23
Product Identification Information.....	6
Product Information Section.....	5
Programming Examples for M50 Protocol.....	38
Diagnostic Codes - Clear	40
Diagnostic Codes - Retrieve	39
G3600 ESS Programming Examples.....	38
Programming Section.....	22
Protocol	22
R	
Reference Material	7
Reference Materials	7
RS-232C Cable Requirements	12
S	
Serial Number Location.....	6
Service Information	21
Service Information Section	19

Specifications	10
Dimensions	10
Environmental	10
Internal Battery	10
Mounting	10
Power Supply	10
System - Troubleshoot.....	19

T

Table of Contents.....	3
Troubleshooting	19

Product and Dealer Information

Note: For product identification plate locations, see the section "Product Identification Information" in the Operation and Maintenance Manual.

Delivery Date: _____

Product Information

Model: _____

Product Identification Number: _____

Engine Serial Number: _____

Transmission Serial Number: _____

Generator Serial Number: _____

Attachment Serial Numbers: _____

Attachment Information: _____

Customer Equipment Number: _____

Dealer Equipment Number: _____

Dealer Information

Name: _____ Branch: _____

Address: _____

Dealer Contact

Phone Number

Hours

Sales: _____

Parts: _____

Service: _____

