

Service Manual

**Electric Protection System
Energize-To-Shutoff (ETS) For
Generator Set, Industrial and Marine
Diesel Engines**

Important Safety Information

Most accidents that involve product operation, maintenance and repair are caused by failure to observe basic safety rules or precautions. An accident can often be avoided by recognizing potentially hazardous situations before an accident occurs. A person must be alert to potential hazards. This person should also have the necessary training, skills and tools to perform these functions properly.

Improper operation, lubrication, maintenance or repair of this product can be dangerous and could result in injury or death.

Do not operate or perform any lubrication, maintenance or repair on this product, until you have read and understood the operation, lubrication, maintenance and repair information.

Safety precautions and warnings are provided in this manual and on the product. If these hazard warnings are not heeded, bodily injury or death could occur to you or to other persons.

The hazards are identified by the "Safety Alert Symbol" and followed by a "Signal Word" such as "DANGER", "WARNING" or "CAUTION". The Safety Alert "WARNING" label is shown below.



The meaning of this safety alert symbol is as follows:

Attention! Become Alert! Your Safety is Involved.

The message that appears under the warning explains the hazard and can be either written or pictorially presented.

Operations that may cause product damage are identified by "NOTICE" labels on the product and in this publication.

Caterpillar cannot anticipate every possible circumstance that might involve a potential hazard. The warnings in this publication and on the product are, therefore, not all inclusive. If a tool, procedure, work method or operating technique that is not specifically recommended by Caterpillar is used, you must satisfy yourself that it is safe for you and for others. You should also ensure that the product will not be damaged or be made unsafe by the operation, lubrication, maintenance or repair procedures that you choose.

The information, specifications, and illustrations in this publication are on the basis of information that was available at the time that the publication was written. The specifications, torques, pressures, measurements, adjustments, illustrations, and other items can change at any time. These changes can affect the service that is given to the product. Obtain the complete and most current information before you start any job. Caterpillar dealers have the most current information available. For a list of the most current publication form numbers available, see the Service Manual Contents Microfiche, REG1139F.

Table of Contents

Systems Operation Section

ETS Introduction	4
ETS Component Descriptions	5
Junction Box and Enclosure Group	12
ETS Junction Box-Switchgear Required (OP,WT,OS)	13
ETS Junction Box-Switchgear Not Required (OP,WT,OS)	33
ETS Junction Box-Switchgear Not Required (OP,WT)	53
Abbreviations and Symbols	66

Testing and Adjusting Section

Troubleshooting

General Troubleshooting Information	75
Electric Protection System Functional Test	75
Troubleshooting the ETS Full Protection System (OP, WT, OS)	77
Troubleshooting the ETS Partial Protection System (OP, WT) (3200-3400 Engines)	85

Testing and Adjusting

General Testing and Adjusting Information	91
Crank Terminate Speed Calibration	94
Diode Test	95
Engine Oil Pressure Switch Test	95
Magnetic Pickup Test	97
Oil Step Speed Calibration	99
Overspeed Calibration	101
Overspeed Verification Test	103
Slave Relay Test	104
Water Temperature Contactor Switch Test	104
Time Delay Relay Verification Test	105

Index Section

Index	107
-------------	-----

Systems Operation Section

i01071866

ETS Introduction

SMCS Code: 7400

The Energize-To-Run (ETR) system and the Energize-To-Shutoff (ETS) system are electric protection systems for engines. The electric protection system will protect the engine from damage if an engine operating function is not within a safe limit. When the engine is purchased, the customer specifies the electric protection system that is installed on the engine.

When the electric protection system detects an unsafe limit, the system will energize the fuel solenoid or the system will de-energize the fuel solenoid. If the engine is not equipped with a fuel solenoid, the 2301A Electric Governor Control may be controlled by the electric protection system. An unsafe limit is called a fault.

The basic difference between the ETR system and the ETS system is the operation of the fuel solenoid. The ETR system de-energizes the fuel solenoid in order to stop the fuel flow which causes engine shutdown. The ETS system energizes the fuel solenoid in order to stop fuel flow which causes engine shutdown.

The ETR system requires the fuel solenoid to be energized in order for the engine to run. The fuel solenoid must be energized before the fuel is allowed to flow to the engine cylinders. After the engine starts and runs, a normal shutdown or a problem with any of the engine functions that are monitored will cause the fuel solenoid to be de-energized. When the fuel solenoid is de-energized, the fuel flow to the cylinders is stopped. This action causes engine shutdown.

The ETS system requires the fuel solenoid to be de-energized in order for the engine to run. The fuel solenoid must be de-energized before the fuel is allowed to flow to the engine cylinders. After the engine starts and runs, a normal shutdown or a problem with any of the engine functions that are monitored will cause the fuel solenoid to be energized. When the fuel solenoid is energized, the fuel flow to the cylinders is stopped. This action causes engine shutdown.

The 2301A Electric Governor Control operates in the same manner in the ETR system and in the ETS system. When the governor control system is installed, the fuel solenoid is not used. When a fault occurs, the governor control system is de-energized. This causes the fuel control linkage to stop the fuel flow to the engine.

The ETR system and the ETS system use two or three engine components in order to monitor as many as six engine operating functions:

- Engine overspeed (OS) which is monitored by the electronic speed switch
- Crank termination which is monitored by the electronic speed switch
- Oil step latch which is monitored by the electronic speed switch (3500 Series Engines)
- Engine oil step pressure which is monitored by the electronic speed switch (3500 Series Engines)
- Water temperature (WT) which is monitored by the water temperature contactor switch
- Oil pressure (OP) which is monitored by one or two oil pressure switches.

Overspeed protection monitors the engine from starting through 118% of rated speed. An engine that is equipped with all three components is called Full Protection System.

An engine which does not have an electronic speed switch is called a Partial Protection System because the electric protection system does not have overspeed protection. The Partial Protection System has only oil pressure protection and water temperature protection.

Two options for the switchgear are available. The first option does not require the switchgear. This option is called Switchgear Not Required. The second option requires the switchgear in order for the electric protection system to function. This option is called Switchgear Required. The switchgear can be purchased from Caterpillar or other suppliers.

Five basic junction box arrangements are available. The arrangements are listed in the table. Variations to these basic arrangements are produced when optional attachments are purchased with the engine. An automatic air shutoff and a starting aid switch are examples of optional attachments.

Table 1

Basic Junction Box Arrangements		
Engine Model	Engine Protection Package	Switchgear Required
3200-3400	OP, WT, and OS	No
3200-3400	OP and WT	No
3200-3400	OP, WT, and OS	Yes
3500	OP, WT, and OS	No
3500	OP, WT, and OS	Yes

i01071893

ETS Component Descriptions

SMCS Code: 7400

Electronic Speed Switch (ESS)

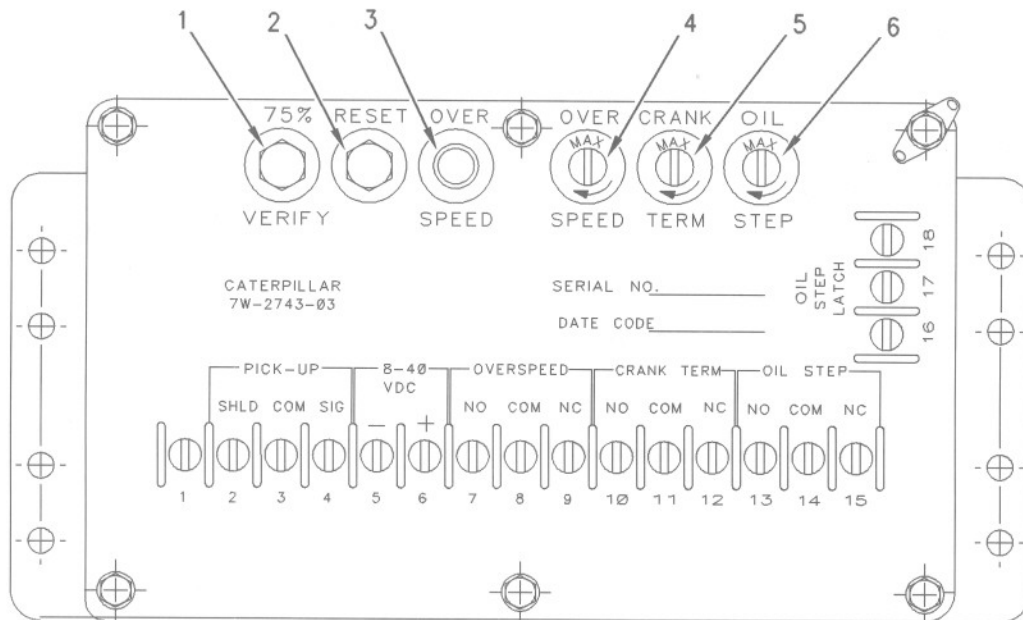

Illustration 1

g00281790

7W-2743 Electronic Speed Switch (ESS)

Table 2

- | | |
|--------------------------|--|
| (1) 75% Verify button. | (4) Seal screw plug for adjusting the overspeed. |
| (2) Reset button. | (5) Seal screw plug for adjusting the crank terminate speed. |
| (3) LED overspeed light. | (6) Seal screw plug for adjusting the oil step pressure speed setting. |

The electronic speed switch (ESS) is a single unit that contains controls which monitor four functions at the same time:

- Engine overspeed
- Crank termination
- Oil step latch
- Engine oil step pressure

Two different electronic speed switches are used. The switches are only different in the location of the mounting holes. The ESS is mounted in the junction box.

Engine Overspeed (OS)

Engine overspeed is an adjustable engine speed setting. The normal setting is 118% of rated speed. The setting prevents the engine from running at a speed that could cause damage to the engine. An engine speed that is greater than the engine speed setting will close a switch which shuts off the fuel to the engine. If the optional air inlet shutoff is provided, the switch will also shut off the inlet air.

Crank Termination

Crank termination is an adjustable engine speed setting that signals the starter motor that the engine is firing and the cranking must be terminated. A switch will open in order to stop the current flow to the starter motor circuit when the engine speed setting is reached. The starter motor pinion gear will then disengage from the engine flywheel ring gear.

Oil Step Latch (3500 Series Engines)

The setting of the oil step latch is not adjustable. After (ESS-17) on the terminal strip of the junction box has been energized by the loss of engine oil pressure, the contacts of the oil pressure step switch are held in the closed position. The oil pressure step switch will remain closed until 2 seconds after the engine has completely stopped. This action will prevent the shutoff from resetting below the oil step speed setting.

Engine Oil Step Pressure (3500 Series Engines)

Engine oil step pressure is an adjustable engine speed setting that gives protection from engine failure which is caused by too little engine oil pressure for a specified speed range. In order to maintain oil pressure protection throughout the complete speed range of operation, two different engine oil pressure switches are used. Switch (OPS1) has a low pressure rating and switch (OPS2) has a high pressure rating. The engine oil pressure switches are mounted in the engine oil manifold that is located on the rear side of the junction box.

The following conditions are for the operation of the oil step latch:

- An engine that uses an oil step latch must maintain an oil pressure that is greater than the rating of the low oil pressure switch (OPS1) when the engine runs below the oil step pressure speed setting.
- An engine that uses an oil step latch must maintain an oil pressure that is greater than the rating of the high oil pressure switch ("OPS2") when the engine runs above the oil step pressure speed setting.

If one of the two conditions for the engine oil pressure are not correct, the low oil pressure alarm switch (LOPAS1) or (LOPAS2) will energize an alarm. OPS1 or OPS2 also energizes the slave relay (SR1). This process de-energizes the fuel solenoid which shuts off the fuel flow to the engine.

The oil pressure switches and the alarm switches are mounted in the engine oil manifold that is located on the rear side of the junction box. The slave relay is mounted in the junction box.

Magnetic Pickup (MPU)

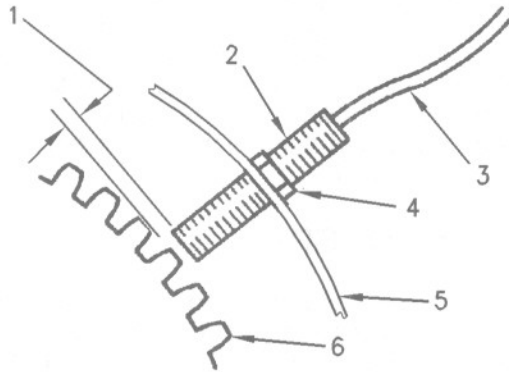

Illustration 2 g00281827

Generation of the Magnetic Pickup Signal

(1) Clearance dimension. (2) Magnetic pickup. (3) Wires to connector. (4) Locknut. (5) Flywheel housing. (6) Flywheel ring gear.

The magnetic pickup is a permanent magnet generator with a single pole. Wire coils surround a permanent magnet pole piece. When the teeth of the flywheel ring gear (6) rotate through the magnetic lines of force that are around the magnetic pickup pole (2), an AC voltage is generated. A positive voltage is generated when each tooth rotates by the pole piece. When the space between the teeth rotates by the pole piece, a negative voltage is generated. Engine speed is measured by the frequency of these signals.

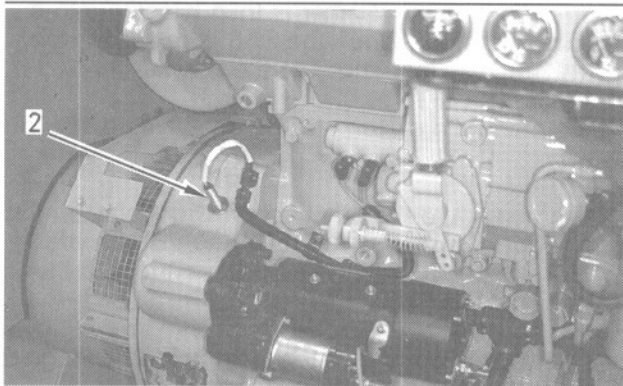

Illustration 3 g00293065

(2) Magnetic pickup sensor that is mounted in the flywheel housing.

The magnetic pickup is mounted through the flywheel housing (5).

Oil Pressure Switch (OPS)

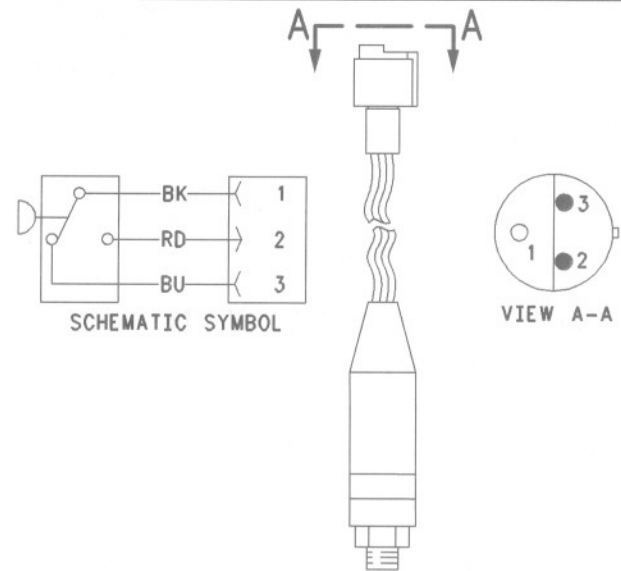

Illustration 4 g00281830

Oil Pressure Switch

The engine oil pressure switch uses a spring loaded piston in order to activate an internal microswitch that is set for a specific pressure rating. This microswitch is very accurate over the operating temperature range. The microswitch also has a high electrical contact rating which improves reliability.

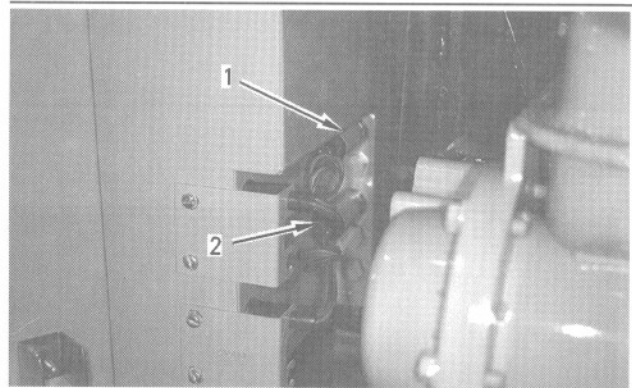

Illustration 5 g00293068

(1) Oil pressure switch (OPS1). (2) Low oil pressure alarm switch (LOPAS1).

The engine oil pressure switches and the alarm switches are mounted on the engine oil manifold that is located on the rear side of the junction box.

3200 Series, 3300 Series, and 3400 Series Engines

The low oil pressure alarm switch is an optional part.

Low oil pressure causes the low oil pressure alarm switch (LOPAS1) to energize an alarm. The oil pressure switch (OPS1) energizes the slave relay (SR1) which then de-energizes the fuel solenoid (FS). This process stops the fuel flow to the engine.

3500 Series Engines

The operation of the oil pressure switches are described in the "Engine Oil Step Pressure (3500 Series Engines)" section of this manual.

Water Temperature Contactor Switch (WTS)

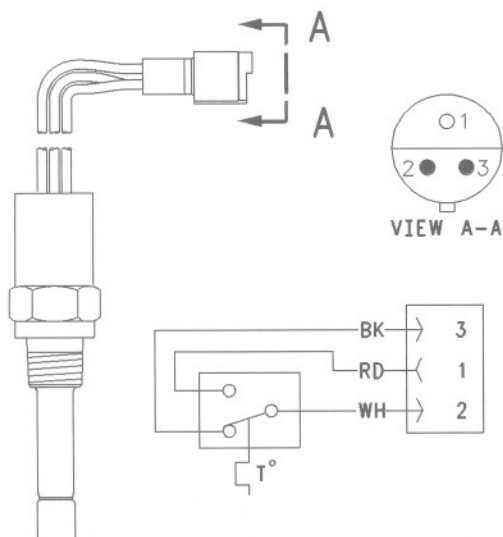

Illustration 6

g00281831

Water Temperature Contactor Switch



Illustration 7

g00293066

(1) Water temperature contactor switch that is mounted in the cylinder block.

The water temperature contactor switch is mounted into the coolant system. The switch is wired to the protection circuit. The switch contains an element that detects the temperature of the coolant. The switch must be in contact with the coolant. When the engine coolant temperature becomes too high, the switch closes. Closure of the switch activates an alarm. Closure of the switch also shuts off the fuel flow to the engine.

Slave Relay (SR)

The slave relays are a standard type. When the slave relay is energized, contacts open across one circuit and contacts close across another circuit. The slave relays control the power to three components:

- Air shutoff solenoid (if equipped)
- Fuel solenoid
- 2301A Electric Governor Control (if equipped)

Slave relays are mounted in the junction box.

Starting Aid Switch (SAS)

The optional starting aid switch is located on the front of the junction box door. The switch is a spring return switch which must be held in the ON position. When the SAS is in the ON position, the valve of the starting aid solenoid (SASV) energizes. A specific amount of ether is then injected into a holding chamber. When the SAS is released, the SASV releases the ether into the engine.

The starting aid switch can be deactivated in two ways:

- The contact of the crank termination relay on the electronic speed switch (ESS) opens at a preset engine speed. This will stop the current to the circuit of the SAS.
- The engine temperature becomes high enough to open the start aid temperature switch (SATS).

NOTICE

The engine must be cranking before using the start aid switch. Damage to the engine is possible if ether is released to the engine but not exhausted or burned by the engine when cranking.

Circuit Breakers (CB)

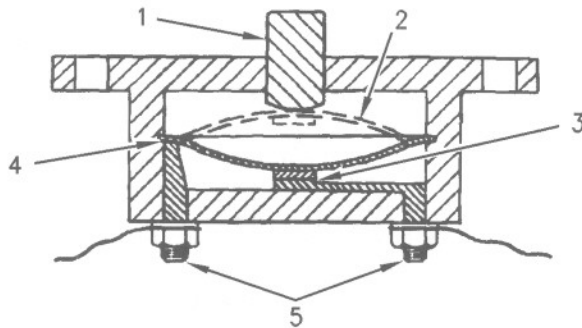

Illustration 8 g00281837
Circuit Breaker
(1) Reset button. (2) Disc in open position. (3) Contacts. (4) Disc in closed position. (5) Battery circuit terminals.

A circuit breaker is a switch that opens the circuit if the current in the electrical system is higher than the rating of the circuit breaker.

A metal disc that is controlled with heat and a contact (3) will complete the circuit through the circuit breaker. If the current in the electrical system is too high, the metal disc becomes too hot. The heat causes a distortion of the metal disc which opens the contacts (2). Open contacts break the circuit. A circuit breaker that is open can be reset after the circuit breaker cools. Push the reset button (1) in order to close the contacts (4) and reset the circuit breaker.

NOTICE

Find and correct the problem that causes the circuit breaker to open.

Correcting the problem before running the engine will help prevent damage to the circuit components caused by too much current.

Air Shutoff Solenoid (ASOS)

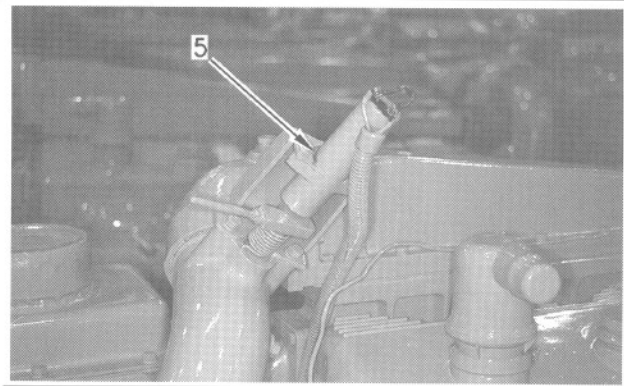

Illustration 9 g00293067
(5) Air shutoff solenoid that is mounted in the air intake pipe.

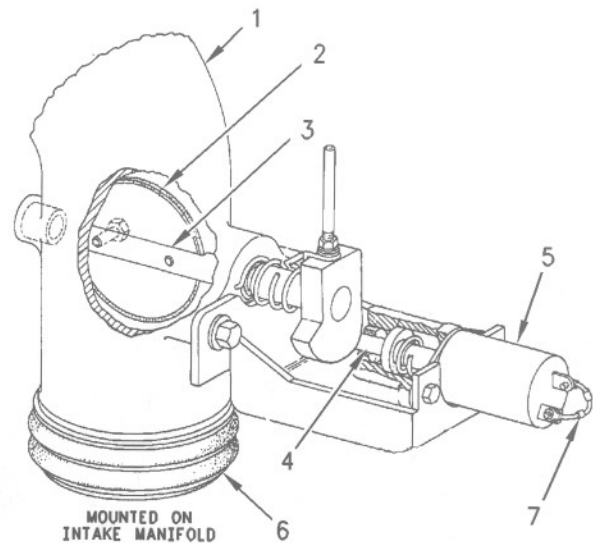

Illustration 10 g00281839
Air Shutoff (Typical Example)

Table 3

(1) Air transfer pipe.	(5) Air shutoff solenoid.
(2) Valve assembly.	(6) O-ring seal.
(3) Shutoff shaft.	(7) Diode assembly.
(4) Governor control shaft.	

The air shutoff solenoid (5) is located in the air inlet system on the top of the engine. When the air shutoff solenoid (ASOS) is activated, the inlet air to the engine is mechanically shut off. The ASOS can be only activated in two ways:

- The ASOS is activated by the overspeed switch (OS).

- The ASOS is activated by the emergency stop switch (ES).

Fuel Shutoff Solenoid (FSOS)

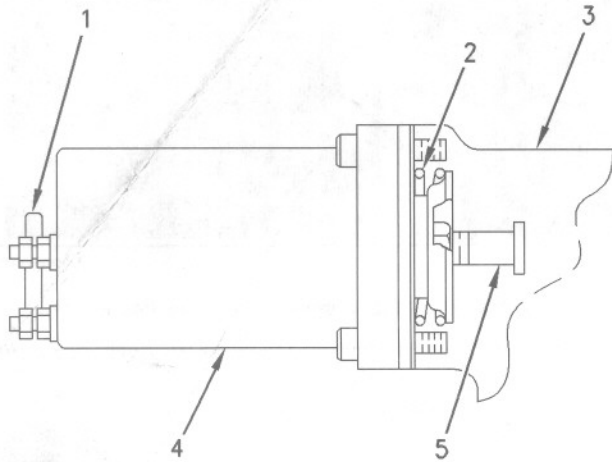

Illustration 11 g00281970
Fuel Solenoid (Typical Example)
(1) Diode assembly.(2) Spring. (3) Governor drive. (4) Fuel solenoid. (5) Shaft.

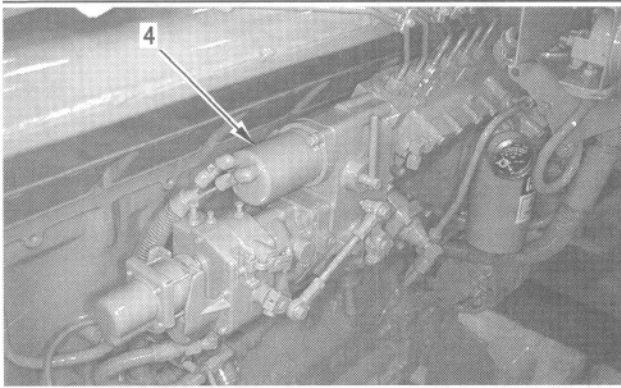

Illustration 12 g00293070
(4) Fuel shutoff solenoid (FSOS) that is mounted on the governor.

The fuel shutoff solenoid (FSOS) (4) is located on the governor or on the fuel injection pump of the engine.

When the FSOS is energized, the spring (2) and the shaft (5) will cause the fuel rack to move directly or the fuel rack will move through governor drive (3) to the FUEL OFF position. The FSOS remains energized until the time delay relay causes the circuit of the FSOS to de-energize.

Time Delay Relay (TD)

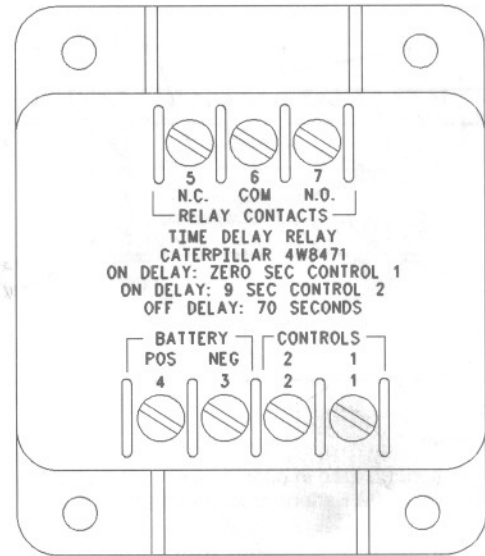

Illustration 13 g00281989
4W-8471 Time Delay Relay

The time delay relay is an ON/OFF switch which has two controls. When the electric protection system is energized, one control will immediately activate the time delay relay. The other control will activate a relay after a delay of 9 seconds when a continuous signal is received. The time delay relay has a 70 second OFF delay after the signal is removed from both the input terminal (TD-1) and the input terminal (TD-2).

The time delay relay is mounted in the junction box.

2301A Electric Governor Control

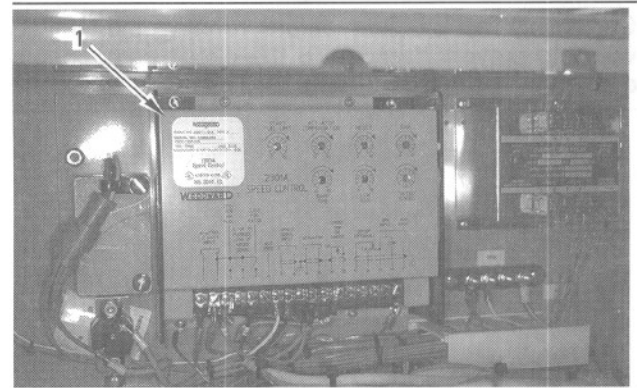

Illustration 14 g00293071
(1) 2301A Electric Governor Speed Control

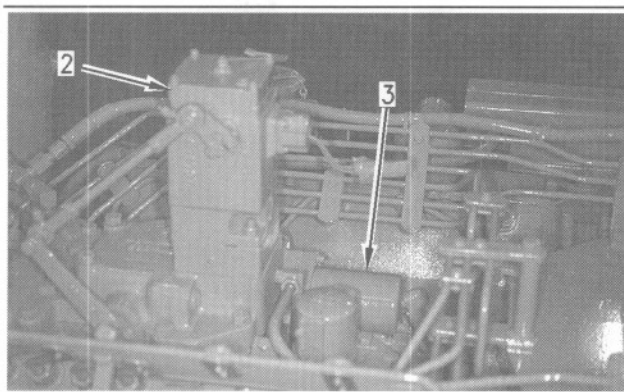

Illustration 15

g00293069

Electric governor actuator (EGA) (2) and fuel shutoff solenoid (FSOS) (3). These components are mounted on the top of the engine.

The 2301A Electric Governor Control system consists of the following components:

- 2301A Control
- Actuator (EGA)
- Magnetic pickup (MPU)

The 2301A Electric Governor Control system provides precision engine speed control. The 2301A Control constantly monitors the engine rpm. The control makes necessary corrections to the engine fuel setting through an actuator connected to the fuel system.

The engine rpm is measured by the magnetic pickup (MU). The magnetic pickup makes an AC voltage that is sent to the 2301A Control. The 2301A Control then sends a DC voltage signal to the actuator in order to adjust the fuel flow.

The actuator changes the electrical signal from the 2301A Control to a mechanical output. The mechanical output of the actuator causes the linkage from the actuator to move the fuel rack. This will increase the flow of fuel to the engine or this will decrease the flow of fuel to the engine. For example, if the engine speed is more than the speed setting, the 2301A Control will decrease the voltage output which causes the actuator to move the linkage in order to decrease the fuel flow to the engine.

Battery Discharge By The Electric Protection System

When the engine is not running there are three components in the electric protection system which continue to draw small amounts of current from the battery:

- Electronic speed switch
- Alternator which charges the battery
- Time delay relay

An electric protection system that has only one of these components can remain shut down for several months without discharging the battery. An electric protection system can remain idle for a minimum of one month without discharging the battery. Cold weather decreases the efficiency of the battery. This increases the discharge of the battery. In most applications, the engine is started weekly or a battery charger is used to keep the battery at full charge. Therefore, few starting problems occur.

The suggestions that follow can be used to prevent battery discharge when the engine is not used for extended time periods. Rental fleets are an example of not operating engines for extended time periods.

If the engine will not be operated for several weeks and if the engine will not be connected to a battery charger, disconnect the battery cable from the negative post (-) of the battery.

A 7N-0718 Battery Disconnect Switch can be installed in order to reduce the discharge of the battery when the engine is not frequently operated for extended periods of time. The switch should be installed between the negative terminal (-) of the battery and the negative terminal (-) of the starting motor. Fabricate a bracket in order to mount the switch. Install the bracket close to the battery or close to the starter motor. The switch can be mounted inside the power distribution box on generator set engines. In all applications, the Battery Disconnect Switch must be mounted within 30° of vertical.

i00670679

Junction Box and Enclosure Group

SMCS Code: 7400

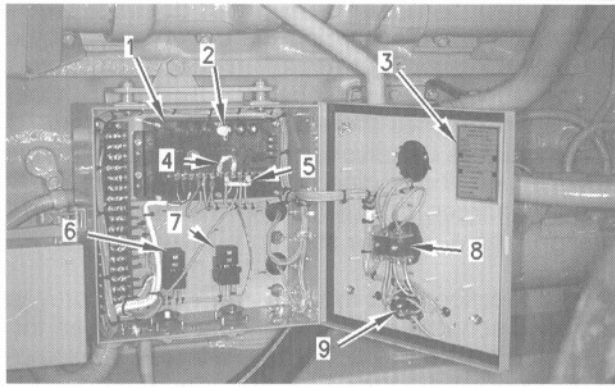

Illustration 16

g00293000

Junction Box-ETR Switchgear Required (OP, WT, OS)

- (1) Electronic speed switch ("ESS").
- (2) Lockwire (for seal screw plugs).
- (3) Identification foil.
- (4) Diode ("D4").
- (5) Diode ("D3").
- (6) Slave relay ("SR1").
- (7) Slave relay ("SR2").
- (8) Emergency stop switch ("ES").
- (9) Circuit breakers.

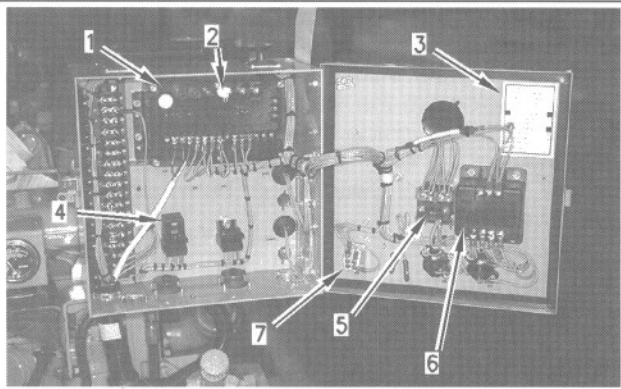

Illustration 17

g00293001

Junction Box-ETS Switchgear Not Required (OP, WT, OS)

- (1) Electronic speed switch ("ESS").
- (2) Lockwire (for seal screw plugs).
- (3) Identification foil.
- (4) Slave relay ("SR1").
- (5) Emergency stop switch ("ES").
- (6) Time delay relay ("TD1").
- (7) Start-stop switch ("SSS").

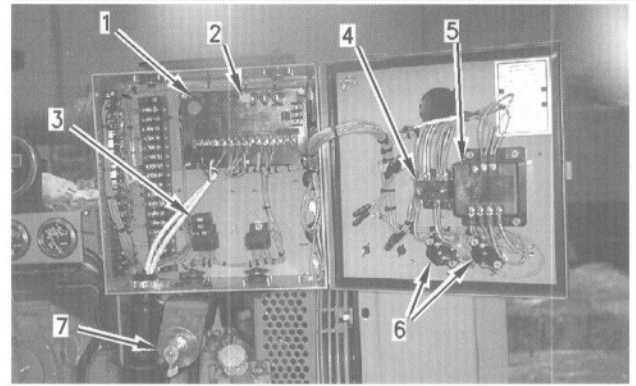

Illustration 18

g00293002

Junction Box-ETS Switchgear Required (OP, WT, OS)

- (1) Electronic speed switch ("ESS").
- (2) Lockwire (for seal screw plugs).
- (3) Slave relay ("SR1").
- (4) Emergency stop switch ("ES").
- (5) Time delay relay ("TD1").
- (6) Circuit breakers.
- (7) Engine mounted start-stop switch ("EMSS").

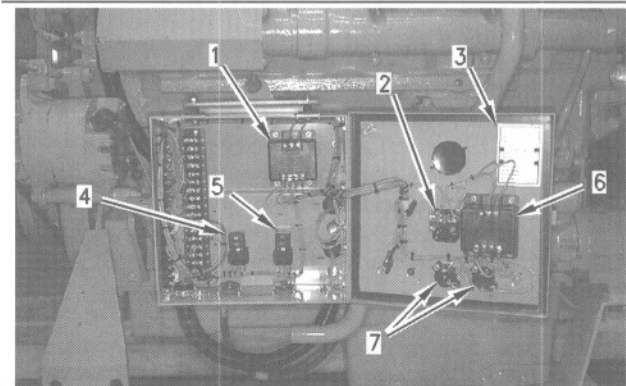

Illustration 19

g00293003

Junction Box-ETS Switchgear Not Required (OP, WT)

- (1) Time delay relay ("TD2").
- (2) Emergency stop switch ("ES").
- (3) Identification foil.
- (4) Slave relay ("SR1").
- (5) Slave relay ("SR2").
- (6) Time delay relay ("TD1").
- (7) Circuit breakers.

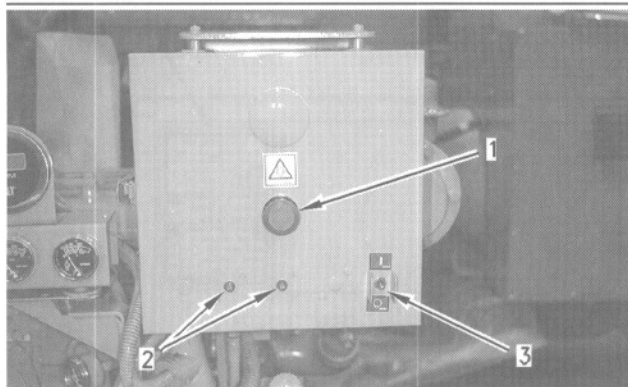

Illustration 20 g00293004

Junction Box With Start-stop Switch ("SSS")

- (1) Emergency stop switch ("ES").
- (2) Circuit breaker reset buttons.
- (3) Start-stop switch ("SSS").

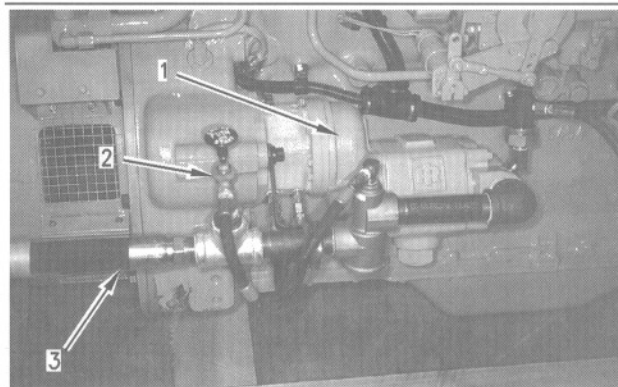

Illustration 23 g00293007

- (1) Air starting motor. (2) Air starting valve. (3) Air supply pipe.

i01071989

ETS Junction Box-Switchgear Required (OP,WT,OS)

SMCS Code: 7400

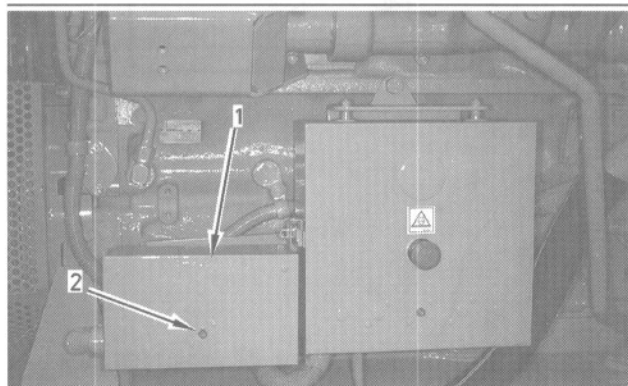

Illustration 21 g00293005

- (1) Power distribution box. (2) Circuit breaker reset button.

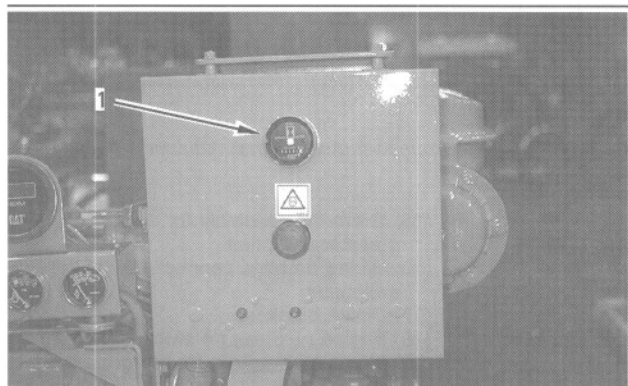
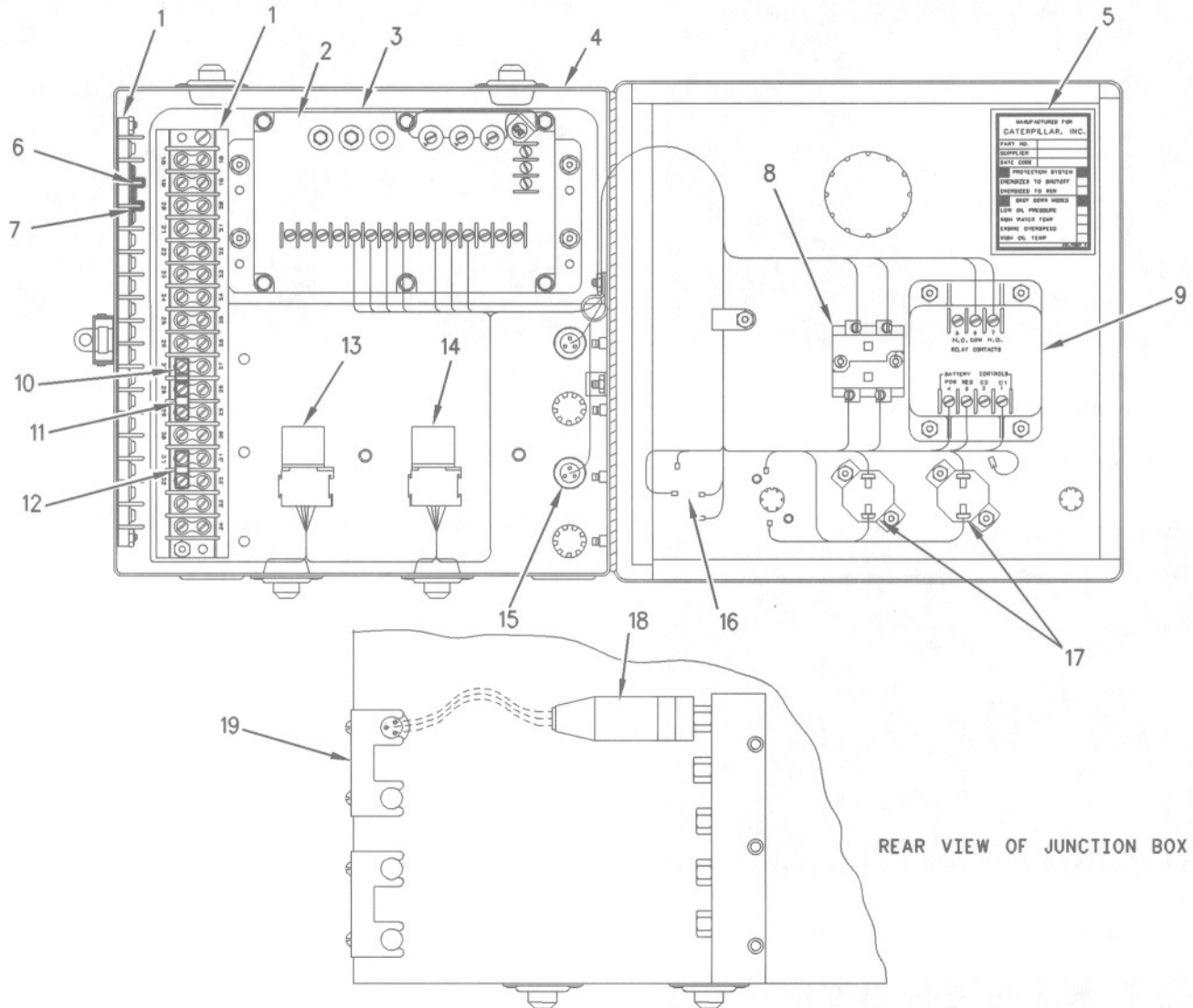

Illustration 22 g00293006

- (1) Hour meter.



REAR VIEW OF JUNCTION BOX

Illustration 24

g00567168

ETS Junction Box with oil pressure protection (OP), water temperature protection (WT), and overspeed protection that requires a switchgear for use on 3200 through 3400 Engines

- | | | |
|--|--|--|
| (1) Terminal strips (TS) | (9) Time delay relay (TD) | (15) Grommet assembly for engine oil pressure switches |
| (2) Electronic speed switch (ESS) | (10) Jumper between terminals (TS-27) and (TS-28) | (16) Wiring harness connections for the switchgear |
| (3) Wiring harness | (11) Jumper between terminals (TS-28) and (TS-29) | (17) Circuit breakers |
| (4) Junction box | (12) Jumper between terminals (TS-30) and (TS-31) | (18) Engine oil pressure switch (OPS1) |
| (5) Identification foil | (13) Slave relay (SR1) | (19) Mounting brackets for the grommet assemblies |
| (6) Jumper between terminals (TS-2) and (TS-3) | (14) Slave relay (SR2) for air shutoff solenoid (ASOS) (if equipped) | |
| (7) Jumper between terminals (TS-3) and (TS-4) | | |
| (8) Emergency stop switch (ES) | | |

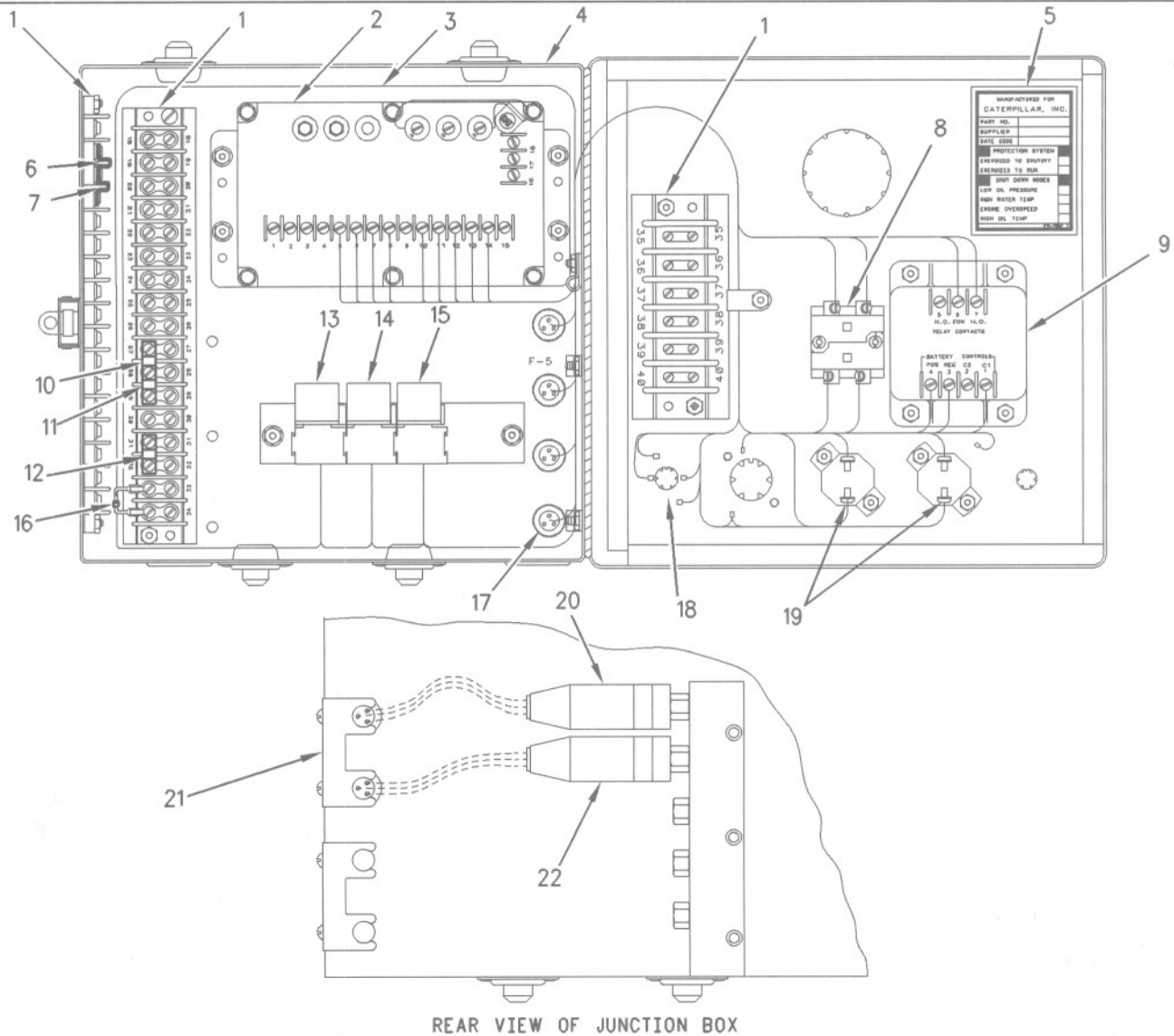

REAR VIEW OF JUNCTION BOX

Illustration 25

g00290563

ETS Junction Box with oil pressure protection (OP), water temperature protection (WT), and overspeed protection (OS) that requires a switchgear for use on 3500 Engines

- | | | |
|---|--|---|
| <ul style="list-style-type: none"> (1) Terminal strips (TS) (2) Electronic speed switch (ESS) (3) Wiring harness (4) Junction box (5) Identification foil (6) Jumper between terminals (TS-2) and (TS-3) (7) Jumper between terminals (TS-3) and (TS-4) (8) Emergency stop switch (ES) (9) Time delay relay (TD) | <ul style="list-style-type: none"> (10) Jumper between terminals (TS-27) and (TS-28) (11) Jumper between terminals (TS-28) and (TS-29) (12) Jumper between terminals (TS-30) and (TS-31) (13) Slave relay (SR1) (14) Slave relay (SR2) for air shutoff solenoid (ASOS) (if equipped) (15) Slave relay (SR3) for starting aid (if equipped) | <ul style="list-style-type: none"> (16) Diode for the electronic governor actuator (if equipped) (17) Grommet assembly for engine oil pressure switches (18) Wiring harness connections for the switchgear (19) Circuit breakers (20) Engine oil pressure switch (OPS1) (21) Mounting brackets for the grommet assemblies (22) Engine oil pressure switch (OPS2) (if equipped) |
|---|--|---|

Introduction

The ETS Junction Box with oil pressure protection (OP), water temperature protection (WT), and overspeed protection (OS) that requires a switchgear is a system that has full protection. The switchgear must be provided by the customer. After the customer's switchgear is wired into the junction box, the electric protection system becomes functional. The system has a junction box arrangement that is designed to monitor four functions:

- Engine overspeed
- Crank termination
- Oil pressure
- Coolant temperature

The junction box includes the following components:

- Electronic speed switch (ESS) (2)
- Slave relay (SR1) (13)
- Slave relay (SR2) (if equipped) with an air shutoff solenoid (ASOS) (14)
- Oil pressure switch (OPS1) (18) and (20)
- Oil pressure switch (OPS2) that is only in 3500 Engines (22)
- Emergency stop switch (ES) (8)
- Time delay relay (TD) (9)

The components that are listed below operate with the junction box. The components are also mounted on the engine.

- Fuel shutoff solenoid (FSOS)
- Air shutoff solenoid (ASOS)
- Water temperature switch (WTS)

The following components must remain de-energized in order for the engine to run with the ETS electric protection system.

- Slave relay (SR1)
- Slave relay (SR2) (if equipped)
- Fuel solenoid (FS)
- Air shutoff solenoid (ASOS)

Electrical Schematics And Wiring Diagrams

This manual contains the point-to-point wiring diagrams for the complete electric protection system and the junction box. Four types of electrical schematics for each electric protection system arrangement are shown in this service manual.

- Junction box wiring diagram
- IEC (International Electro-Technical Commission) schematic
- JIC (Joint Industrial Council) schematic
- Junction box wiring harness diagram

Note: The line number that follows a component code gives the location of the component on the IEC and JIC schematics.

Circuit Operation With No Faults

The steps that follow use a start/stop switch with three positions in order to interface with the switchgear that is supplied by the customer. Connect the contacts of the switch to the terminal strip in the junction box.

1. Connect the contacts for the START position between terminals (TS-21) and (TS-26) of the junction box.
2. Connect the second set of contacts for the START position. The contacts are between terminals (TS-5) and (TS-14) of the junction box.
3. Connect the contacts for the RUN position across the terminals (TS-4) and (TS-5) of the junction box.
4. Connect the contacts for the STOP position across the terminals (TS-4) and (TS-10) of the junction box.

Note: In order to prevent the premature engine shutdown, the start/stop switch must be held in the START position until the engine oil pressure is observed on the engine oil pressure gauge.

Engine Shutdown

When the engine is stopped, power is always available across the terminals (ESS-5) and (ESS-6) (line 53) of the electronic speed switch (ESS). Power is also available across terminals (TD-3) and (TD-4) (line 12) of the time delay relay (TD). All of the switches are in the normally open position or the normally closed positions at that time.

Connections For Temporary Start-up

If an engine with this system must be temporarily started before the final installation, use the following steps in order to wire the engine.

1. Connect a jumper wire across the terminals (TS-7) and (TS-8).
2. Connect a jumper wire across the terminals (TS-8) and (TS-10).
3. Connect the contacts for the START position on a start/stop switch across the terminals (TS-21) and (TS-26).
4. Connect the contacts for the STOP position on a start/stop switch across the terminals (TS-4) and (TS-10).

All fault circuits are now operational. However, the start/stop switch must remain in the START until sufficient oil pressure exists. A sufficient amount of engine oil pressure must exist and the start/stop switch must be in the START position. If these conditions are not met, the engine will stop. In order to prevent premature engine shutdown, the start/stop switch must remain in the START position until the engine oil pressure is sufficient enough to open the engine oil pressure switch (OPS1). This condition should occur when oil pressure is observed on the oil pressure gauge.

Engine Start-up

The start/stop switch that is installed by the customer should have three positions:

- START
- RUN
- STOP

When the start/stop switch is moved to the START position, the following events should occur in the electric circuit.

1. The start/stop switch closes the circuit to the starter motor.
2. The starter motor magnetic switch (SMMS) (line 9) closes a contact (line 3) which energizes the pinion solenoid (PS) (line 3).
3. The PS closes a contact (line 2) which energizes the starter motor (SM).

When the toggle of the start/stop switch is held in the START position, power is always available to the starter motor until the engine begins to run. When the engine begins to run, the crank terminate switch (CT) stops the current that runs to the starter motor. When the engine begins to run, move the start/stop switch to the RUN position. If the engine oil pressure is too low to open the oil pressure switch (OPS1), the contacts across terminals (OPS1-1) and (OPS1-3) (line 15) open after the 9 second time limit. The slave relay (SR1) (line 36) is energized and the engine will shut down. Refer to "Fault Circuit Operation" for the complete circuit description under these conditions.

Note: If an electric starting motor is not used and an alternator is not used to run the engine, connect the power source to the engine. Connect the positive lead of the power source to terminal (TS-1) and connect the negative lead to terminal (TS-28) of the junction box. If an electric starting motor is not used and an alternator is used, the battery can still be used to run the engine. Connect the battery cables to the studs for the power input which are located on the bottom of the power distribution box.

Engine Operation

When the engine starts to run and the speed setting of the crank termination is reached, the crank terminate switch stops the current to the starter motor circuit. The starter motor will stop even if the start/stop switch (SSS) is held in the START position. The crank terminate switch is located in the electronic speed switch. When crank termination is reached, the following events occur in the electric circuit.

1. The contacts for the crank terminate switch open across terminals (ESS-11) and (ESS-12) (line 9). The contacts across terminals (ESS-10) and (ESS-11) (line 13) close.
2. When the contacts of the CT open across terminals (ESS-11) and (ESS-12), the current flow is stopped to the starter motor circuit and the starter motor (SM) will stop.
3. The other contacts of the CT close across terminals (ESS-11) and (ESS-10) in order to energize "Control 2" at terminal (TD-2) of the time delay relay (TD) (line 13).
4. After 9 seconds, the TD closes contacts across terminals (TD-6) and (TD-7) (line 36) in order to arm the shutoff circuit to the slave relay (SR1) (line 36).

5. When the engine oil pressure increases enough to make the contacts of the engine oil pressure switch (OPS1) (line 15) open across the terminals (OPS1-1) and (OPS1-3) and close across the terminals (OPS1-1) and (OPS1-2), "Control 1" at terminal (TD-1) of the time delay relay will be energized.
6. When "Control 1" is energized, the contacts across terminals (TD-6) and (TD-7) (line 36) will close. This arms the shutoff circuit to (SR1).

Both "Control 1" and "Control 2" must be energized in order for the engine to continue running.

3500 Engines Running At A Rated Speed

When the oil pressure step switch (OPSS) (line 17) is closed across terminals (ESS-14) and (ESS-13) and oil pressure switch (OPS2) (line 17) is open across contacts (OPS2-1), no current flow to the slave relay (SR1) (line 36) exists. The switches will remain in these positions and the engine will continue to run under the following conditions:

- No engine problems exist.
- The engine is running at a rated speed.
- The engine is running at a speed above the oil step speed setting, which is optional.

(OPS2) (line 17) will not open across contacts (OPS2-1) and (OPS2-3) until the oil pressure increases to the rating of the switch (OPS2) for a particular engine. After (OPS2) is open, the switch will not close until the oil pressure has dropped approximately 35 kPa (5 psi) below the pressure rating that opened the switch.

The oil pressure step switch (OPSS) is not controlled by engine oil pressure. The OPSS (line 17) is controlled by the engine speed.

The speed setting of the oil pressure step switch is adjustable. The OPSS is energized when the oil pressure is equal to the speed setting of the OPSS or greater than the speed setting of the OPSS. However, the oil pressure step switch has a 9 second delay before the switch can close across terminals (ESS-14) and (ESS-13). This delay provides the time that is needed for the engine oil pressure to increase in order to open the switch (OPS2). The system could constantly activate engine shutdown without the time delay.

3500 Engines Running At A Speed Below The Oil Step Speed Setting

If the engine continues to run at a speed below the oil step speed setting, the oil pressure step switch (OPSS) (line 17) remains open. The OPSS will not complete the circuit in order to shut down the engine when the switch (OPS2) (line 17) is closed across the contacts (OPS2-1) and (OPS2-3).

If the engine oil pressure increases enough to open the switch (OPS1) (line 15) across contacts (OPS1-1) and (OPS1-3), the engine can safely run at this speed. The oil pressure circuit will not cause shutdown.

If the engine accelerates through the oil step speed setting, the circuit might remain in the same state that is described above. When the engine speed is equal to the setting of the OPSS or greater than the setting of the OPSS, the engine oil pressure must be greater than the rated speed for (OPS2). This will open (OPS2) (line 17) within the 9 second time delay that is needed for the oil pressure step switch (OPSS) to remain open. If the engine oil pressure is not greater than the rated speed for (OPS2), the following events may occur:

1. The OPSS (line 17) will close across contacts (ESS-14) and (ESS-13) after 9 seconds.
2. Engine shutdown will occur if (OPS2) remains closed across the contacts (OPS2-1) and (OPS2-3).
3. The (OPS2) cannot open before the OPSS closes. The engine will continue to run.

Normal Stop Switch

The engine is stopped by moving the start/stop switch. The switch is moved from the RUN position to the STOP position.

The following events occur in the electric circuit when the start/stop switch is moved to the STOP position.

1. The start/stop switch closes across contacts (SSS-5) and (SSS-6) in order to energize the time delay relay (TD) (line 36).
2. The current then flows through contacts (TD-6) and (TD-7) (line 36) of the time delay relay (TD).
3. Current through the TD energizes slave relay (SR1) (line 36) which closes across contacts (SR1-30) and (SR1-87) (line 43).

4. When slave relay (SR1) (line 36) is energized, the fuel shutoff solenoid (FSOS) (line 43) is also energized, and the fuel flow to the engine is stopped.
5. When the engine stops, the crank terminate switch (CT) closes across terminals (ESS-11) and (ESS-12) (line 9), which allows the engine to restart.

The engine can now be restarted.

Emergency Stop Switch

The push button of the emergency stop switch is located on the front of the junction box door. The push button is red and the push button has a round shape. When this push button is depressed, the switch is in the OFF position which shuts down the engine. The push button will remain depressed until the push button is manually released to the ON position. The engine cannot be restarted if the push button is depressed.

When the push button is depressed, the following events occur in the electric circuit in order to stop the engine.

1. An open circuit is made across contacts (ES-1A) and (ES-2A) (line 9).
2. A closed circuit is made across the contacts (ES-3A) and (ES-4A) (line 33) which energizes the slave relays (SR1) (line 36) and (SR2) (line 33).
3. When (SR2) is energized, and if (SR2) is equipped with an air shutoff solenoid, the circuit closes across the contacts (SR2-30) and (SR2-87) (line 47) in order to energize the air shutoff solenoid (ASOS).
4. This effectively stops the inlet air to the engine. The ASOS remains energized until the contacts (ESS-10) and (ESS-11) (line 13) of the CT switch open. The contacts will open after the engine stops.
5. The slave relay (SR1) (line 36) is energized when the circuit closes across the contacts (ES-3A) and (ES-4A).
6. The current then flows through the diode (D2) (line 35). This causes (SR1) to close the contacts (SR1-30) and (SR1-87) (line 43). These contacts are normally open.
7. When (SR1) energizes, the fuel shutoff solenoid (FSOS) is also energized. This stops the fuel flow to the engine.

WARNING

Accidental engine starting can cause injury or death to personnel working on the equipment.

To avoid accidental engine starting, disconnect the battery cable from the negative (-) battery terminal. Completely tape all metal surfaces of the disconnected battery cable end in order to prevent contact with other metal surfaces which could activate the engine electrical system.

Place a Do Not Operate tag at the Start/Stop switch location to inform personnel that the equipment is being worked on.

In order to start the engine again, perform the following procedures.

1. Correct any faults that might cause the emergency shutdown.
2. Manually reset the air shutoff lever which is located at the top of the air inlet housing.
3. Make sure that the push button of the emergency stop switch has been reset on the junction box of the engine. Turn the push button in the direction that is shown on the face of the push button in order to reset the button. The push button moves outward in order to reset.
4. Move and hold the toggle of the start/stop switch in the START position in order to restart the engine. If the engine is equipped with an engine mounted start switch, the lever of the switch must be in the START position in order to restart the engine.

Fault Circuit Operation

Oil Pressure Fault ("OPS1")

When the engine starts and the engine begins to run, the crank terminate switch (CT) opens. This arms the electric protection system. The following events occur in the electric circuit in order to arm the electric protection system.

1. The CT switch opens across the terminals (ESS-11) and (ESS-12) (line 9). The switch closes across terminals (ESS-11) and (ESS-10) (line 13).
2. The CT switch arms the electric protection system when a current is sent to "Control 2" at terminal (TD-2) of the time delay relay (line 13).

The engine oil pressure switch (OPS1) (line 15) must open within 9 seconds after the electric protection system is armed. The engine oil pressure must increase to the rating that is necessary to open (OPS1). The following events occur in the electric circuit if (OPS1) does not open across contacts (OPS1-1) and (OPS1-2).

1. The contacts of the time delay relay (TD) will close across terminals (TD-6) and (TD-7) (line 36). This energizes the slave relay (SR1) (line 36).
2. The current then flows through the contacts (OPS1-1) and OPS1-3 to terminal (ESS-17) through the diode (D4) (line 17).
3. The current flows through the jumper between (TS-9) and (TS-10) (line 21).
4. The current flows through contacts (TD-6) and (TD-7). This energizes the slave relay (SR1).
5. Slave relay (SR1) opens across the contacts (SR1-30) and (SR1-87a) (line 45). The relay closes across the contacts (SR1-30) and (SR1-87) (line 43).
6. When (SR1) energizes, the fuel shutoff solenoid (FSOS) (line 43) is also energized. This stops the fuel flow to the engine.

The electric protection system will cause engine shutdown in the same way that is described in the previous paragraph if the engine is running under the following conditions:

- No faults
- A speed that is less than the oil step speed setting
- The engine oil pressure falls below the minimum pressure rating of the oil pressure switch.

The (OPS1) closes across the contacts (OPS1-1) and (OPS1-3) (line 15) when the oil pressure decreases to the minimum pressure rating, which causes immediate engine shutdown.

NOTICE

To avoid possible engine damage or another immediate shutdown, the engine oil pressure fault must be corrected before attempting to restart the engine.

The oil step latch is only used on 3500 Series Engines. The oil step latch is energized at terminal (ESS-17) by the events that are described above. The contacts (ESS-11) and (ESS-12) of the crank terminate switch (CT) open. The contacts remain open until 2 seconds after the engine speed can no longer be detected. An attempt to start the engine will be cancelled until two seconds after the flywheel rotation has stopped.

NOTICE

To avoid possible damage to the starter motor pinion and the engine flywheel ring gear, do not attempt to restart the engine until the engine rotation has completely stopped.

WARNING

Accidental engine starting can cause injury or death to personnel working on the equipment.

To avoid accidental engine starting, disconnect the battery cable from the negative (-) battery terminal. Completely tape all metal surfaces of the disconnected battery cable end in order to prevent contact with other metal surfaces which could activate the engine electrical system.

Place a Do Not Operate tag at the Start/Stop switch location to inform personnel that the equipment is being worked on.

Oil Pressure Fault (OPS2) (3500 Engines) Only

A fault occurs in the high pressure side of the oil pressure circuit when the engine is running at a speed above the oil step speed setting. A fault also occurs when the engine oil pressure falls below the pressure setting of (OPS2). The oil step speed setting is adjustable.

When the engine is running at a speed that is above the oil step speed setting, the current will follow the same path that is described in the "Oil Pressure Fault (OPS1)" section of this manual. However, the oil pressure step switch (OPSS) is closed across contacts (ESS-14) and (ESS-13) (line 13). Also, the oil pressure switch (OPS2) is closed across contacts (OPS2-1) and (OPS2-2). The OPSS switch is already closed because the engine has been running at a speed above the step oil pressure setting.

When the engine oil pressure decreases below the high pressure rating of (OPS2), the following events occur in the electric circuit in order to stop the engine.

1. The engine oil pressure switch (OPS2) opens across contacts (OPS2-1) and (OPS2-2) and the engine oil pressure switch closes across (OPS2-1) and (OPS2-3).
2. The voltage drop across terminal (ESS-17) causes the contacts (OPSS-13) and (OPSS-14) of the OPSS to close. The contacts will remain closed for two seconds after the engine speed can not be detected.
3. The current then flows through diode (D4) (line 17) and the current also flows through the jumper across the terminals (TS-9) and (TS-10) (line 20).
4. The current flows through the contacts (TD-6) and (TD-7) (line 36) of the time delay relay which energizes the slave relay (SR1) (line 43).
5. When (SR1) is energized, the switch opens across contacts (SR1-30) and (SR1-87a) (line 45). The switch closes across contacts (SR1-30) and (SR1-87) (line 43).
6. The energized (SR1) energizes the fuel shutoff solenoid (FSOS) (line 43) which stops the fuel flow to the engine.

NOTICE

To avoid possible engine damage or another immediate shutdown, the engine oil pressure fault must be corrected before attempting to restart the engine.

 **WARNING**

Accidental engine starting can cause injury or death to personnel working on the equipment.

To avoid accidental engine starting, disconnect the battery cable from the negative (-) battery terminal. Completely tape all metal surfaces of the disconnected battery cable end in order to prevent contact with other metal surfaces which could activate the engine electrical system.

Place a Do Not Operate tag at the Start/Stop switch location to inform personnel that the equipment is being worked on.

Engine Overspeed (OS)

When the engine speed increases above the overspeed setting of the electronic speed switch, the overspeed switch (OS) will cause engine shutdown. The following events occur in the electric circuit in order to shut down the engine.

1. When the overspeed occurs, the ESS closes across the terminals (ESS-8) and (ESS-7) (line 29).
2. The current flows from the battery to the crank terminate switch (CT) and across the terminals (ESS-11) and (ESS-10) (line 13).
3. The current flows through the overspeed switch (OS) and to the slave relay (SR2) (line 33). If the overspeed switch (OS) is equipped with an air shutoff solenoid, the solenoid becomes energized.
4. The (SR2) closes across the contacts (SR2-30) and (SR2-87) (line 47) in order to activate the air shutoff solenoid (ASOS), if equipped.
5. The current flows through the diode (D2) (line 35) to the slave relay (SR1) (line 36) which becomes energized.
6. The (SR1) opens across the contacts (SR1-30) and (SR1-87a) (line 45). The (SR1) closes across the contacts (SR1-30) and (SR1-87) (line 43).
7. When (SR1) energizes, the fuel shutoff solenoid (FSOS) (line 43) becomes energized.
8. When the fuel shutoff solenoid (FSOS) (line 43) is energized, the fuel flow is stopped to the engine.

A reset button on the electronic speed switch must be pushed in order to open the overspeed switch. The air shutoff lever must be manually reset to the open position before the engine can be restarted. The air shutoff lever is located at the top of the air inlet housing.

 **WARNING**

Accidental engine starting can cause injury or death to personnel working on the equipment.

To avoid accidental engine starting, disconnect the battery cable from the negative (-) battery terminal. Completely tape all metal surfaces of the disconnected battery cable end in order to prevent contact with other metal surfaces which could activate the engine electrical system.

Place a Do Not Operate tag at the Start/Stop switch location to inform personnel that the equipment is being worked on.

Water Temperature Fault

The current flow for the circuit that is described in this section is applicable for all engines. The engine must be running at a speed with a coolant temperature that is hot enough to close the water temperature contactor switch (WTS). The water temperature contactor switch is normally open. The following events occur in the electric circuit in order to shut down the engine. The engine will shut down when the temperature of the coolant system is greater than the maximum temperature that is set for the WTS.

1. When the WTS closes, the current flows across the terminals (TS-2) and (TS-7) (line 18).
2. Current flows through the diode (D3) (line 19) and through the jumper between (TS-9) and (TS-10) (line 21).
3. The current flows through the contacts (TD-6) and (TD-7) (line 36) of the time delay relay in order to energize the slave relay (SR1) (line 36).
4. When the (SR1) is energized, the switch closes across contacts (SR1-30) and (SR1-87) (line 43).
5. When the (SR1) is energized, the fuel shutoff solenoid (FSOS) (line 43) also becomes energized. This stops the fuel flow to the engine.

NOTICE

To avoid possible engine damage or another immediate shutdown, the water temperature fault must be corrected before attempting to restart the engine.

Even though the starter motor circuit can now be engaged, there is no fuel flow to the engine. The fuel flow to the engine is stopped until the coolant temperature falls below the rating for the water temperature contactor switch (WTS). When the coolant temperature falls below the rating for the water temperature contactor switch (WTS), the contactor switch opens again. The fuel shutoff solenoid is de-energized when the switch reopens. This allows fuel flow to the engine. The engine can then be restarted.

2301A Electric Governor Control

The 2301A Electric Governor Control activates all of the components that are in the electric protection system. The components are activated in the same manner when the nonelectric governor is used. One difference exists in the main circuit. The fuel shutoff solenoid (FSOS) (line 43) is not used.

When the electric governor control is used, the engine must run in a normal condition in order for the electric circuit to operate in the manner that is described below.

1. Current flows from the terminals (TS-28) (line 43) and (TS-31) (line 44), which are located on the terminal strip in the junction box.
2. Current from terminals (TS-28) (line 43) and (TS-31) (line 44) flows through the preregulator (PR) (line 48) or the fuse (F4) to the electric governor control.
3. When the engine flywheel is rotating, the current also flows through the electric governor actuator (EGA) (line 52).

When a fault in the system causes the current to energize the slave relay (SR1), the following events occur in the electric circuit in order to stop the engine.

1. The slave relay (SR1) opens across the contacts (SR1-30) and (SR1-87a) (line 45). The relay closes across the contacts (SR1-30) and (SR1-87) (line 43).
2. When the circuit opens across contacts (SR1-30) and (SR1-87a), the current is stopped to the electric governor control.
3. Current to the electric governor actuator (EGA) is also stopped.
4. The mechanical spring load in the electric governor actuator (EGA) will now move the fuel control rod in order to stop fuel flow to the engine.

Note: With the exception of the differences that are described in this section of the manual, all of the fault circuits in the electric protection system are identical for the 2301A Electric Governor Control and for the nonelectric governor control.

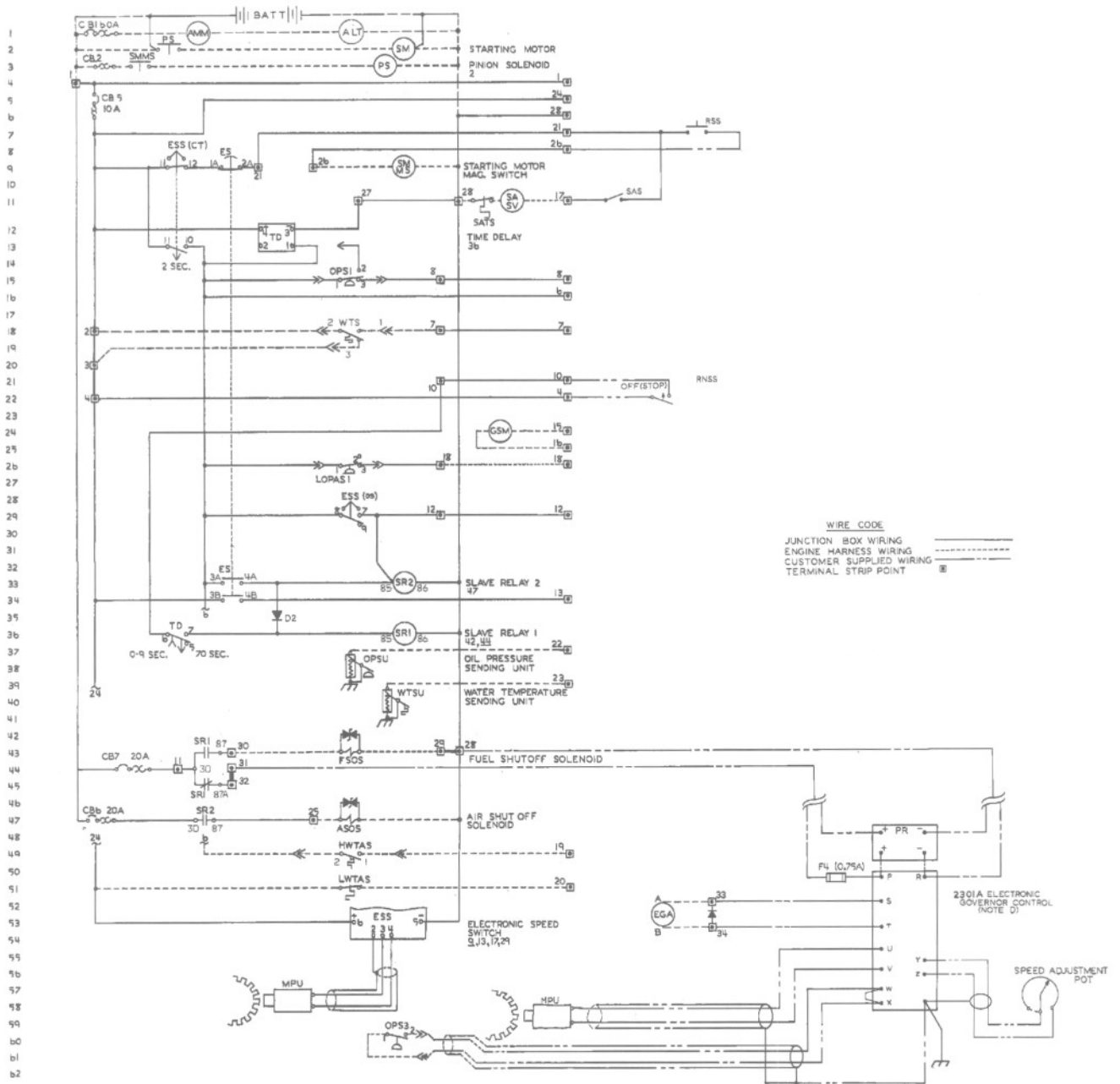
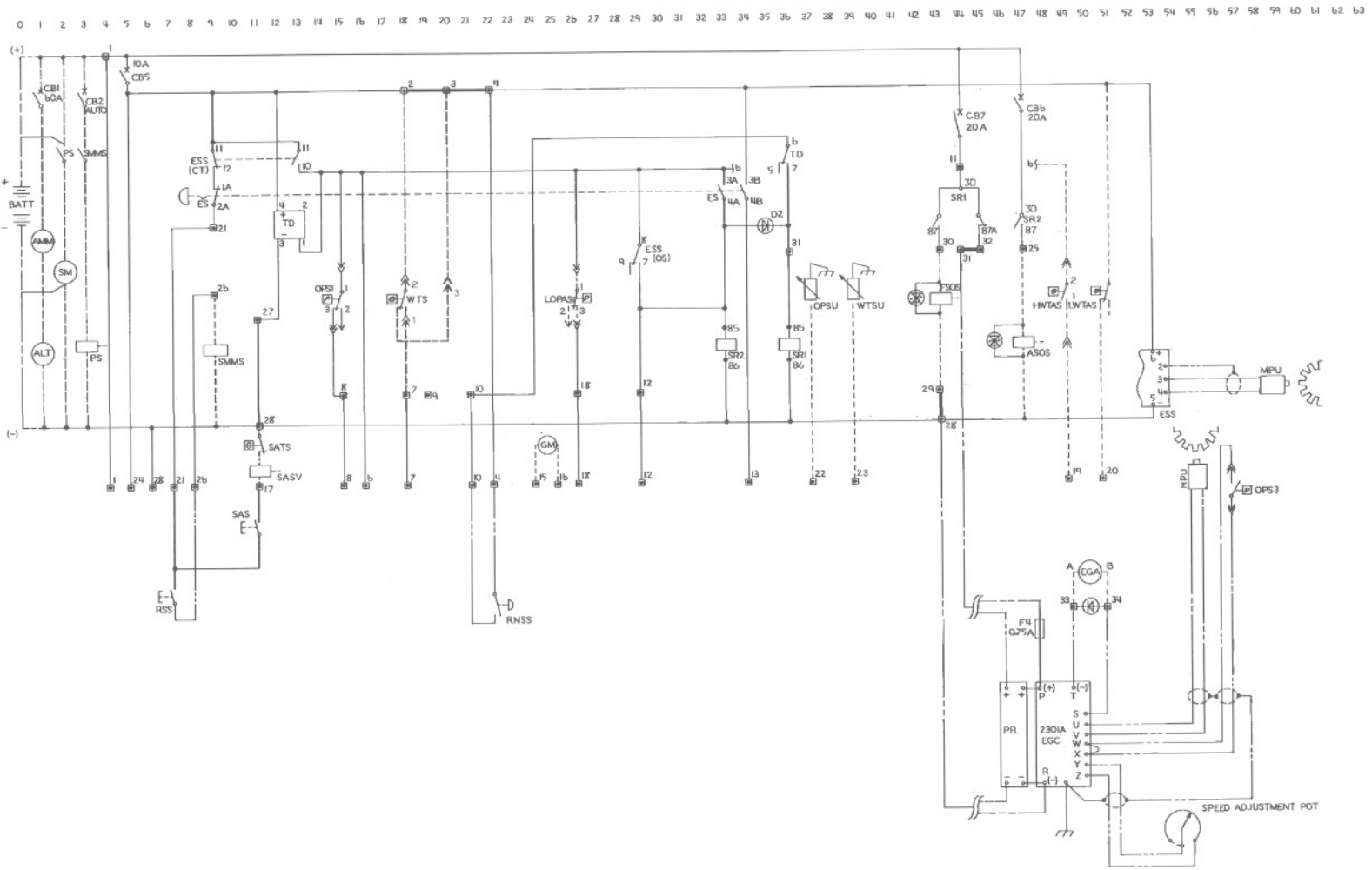

Illustration 27

g00292520

JIC Schematic for ETS with OP, WT, and OS that requires a switchgear for use on 3200 through 3400 Engines



DC SCHEMATIC - IEC SYMBOLS

Illustration 28
IEC Schematic for ETS with OP, WT, and OS that requires a switchgear for use on 3200 through 3400 Engines

g00292521

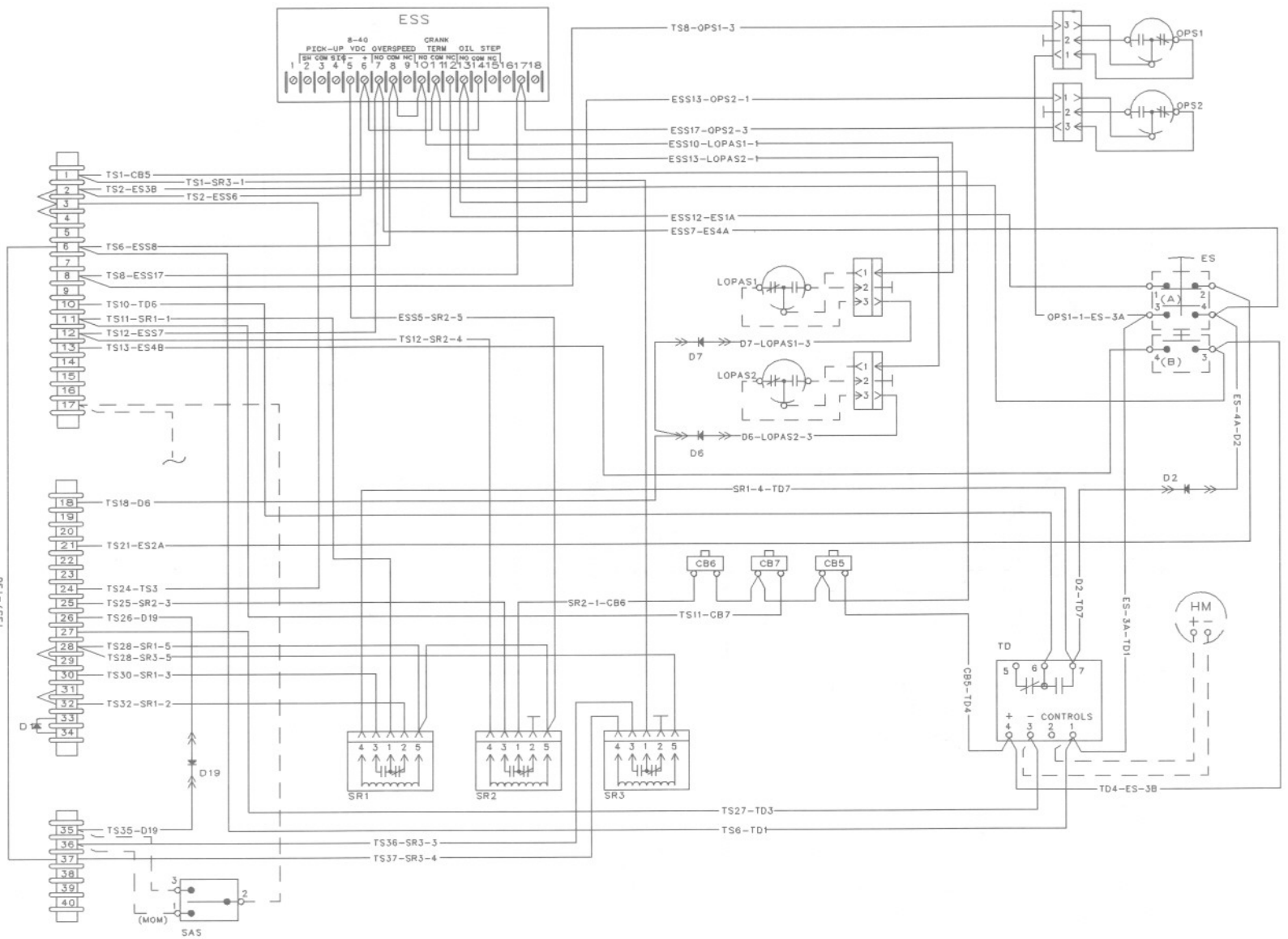

Illustration 30
Junction Box Wiring for ETS with OP, WT, and OS that requires a switchgear for use on 3500 Engines

900292524

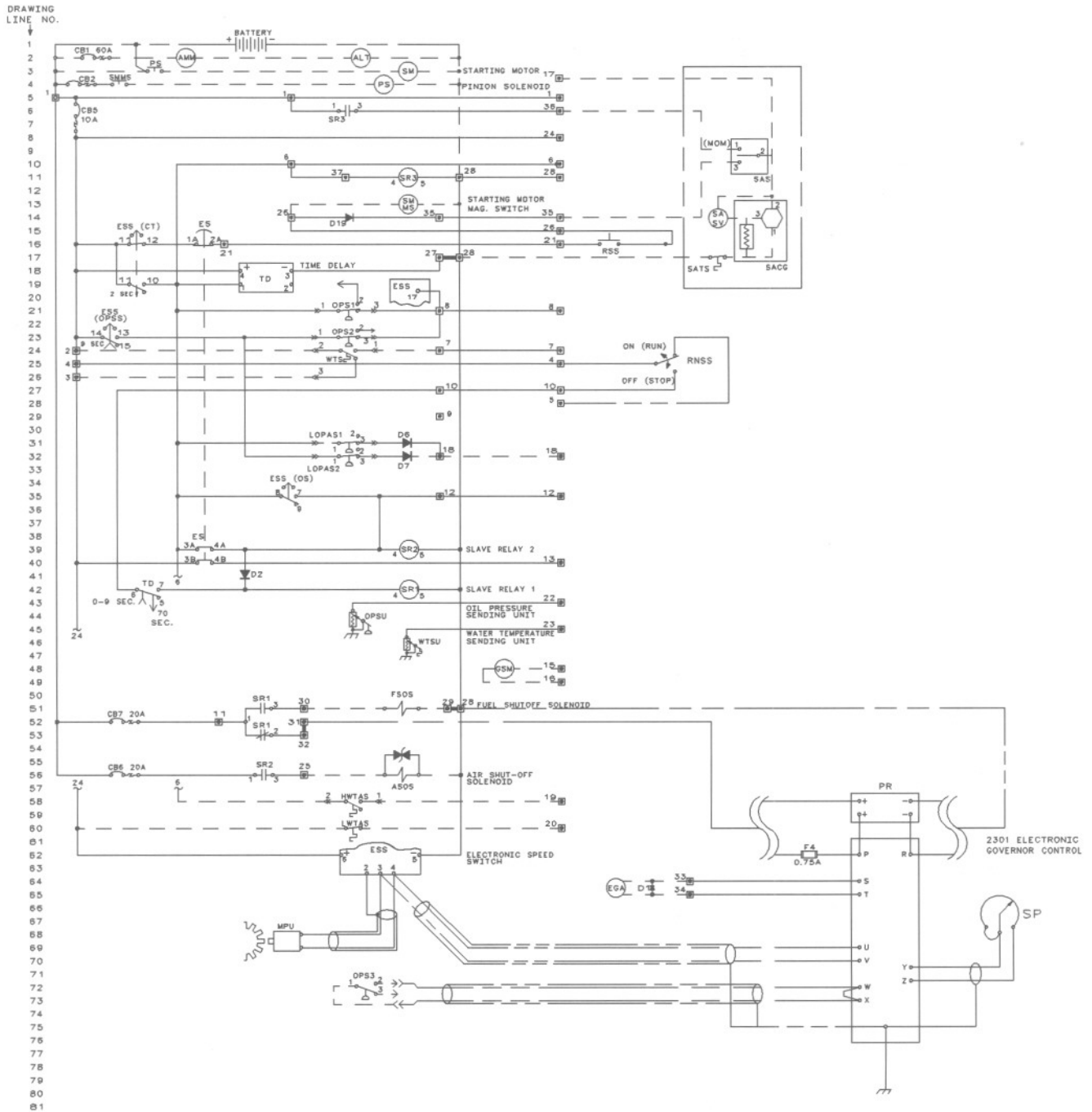
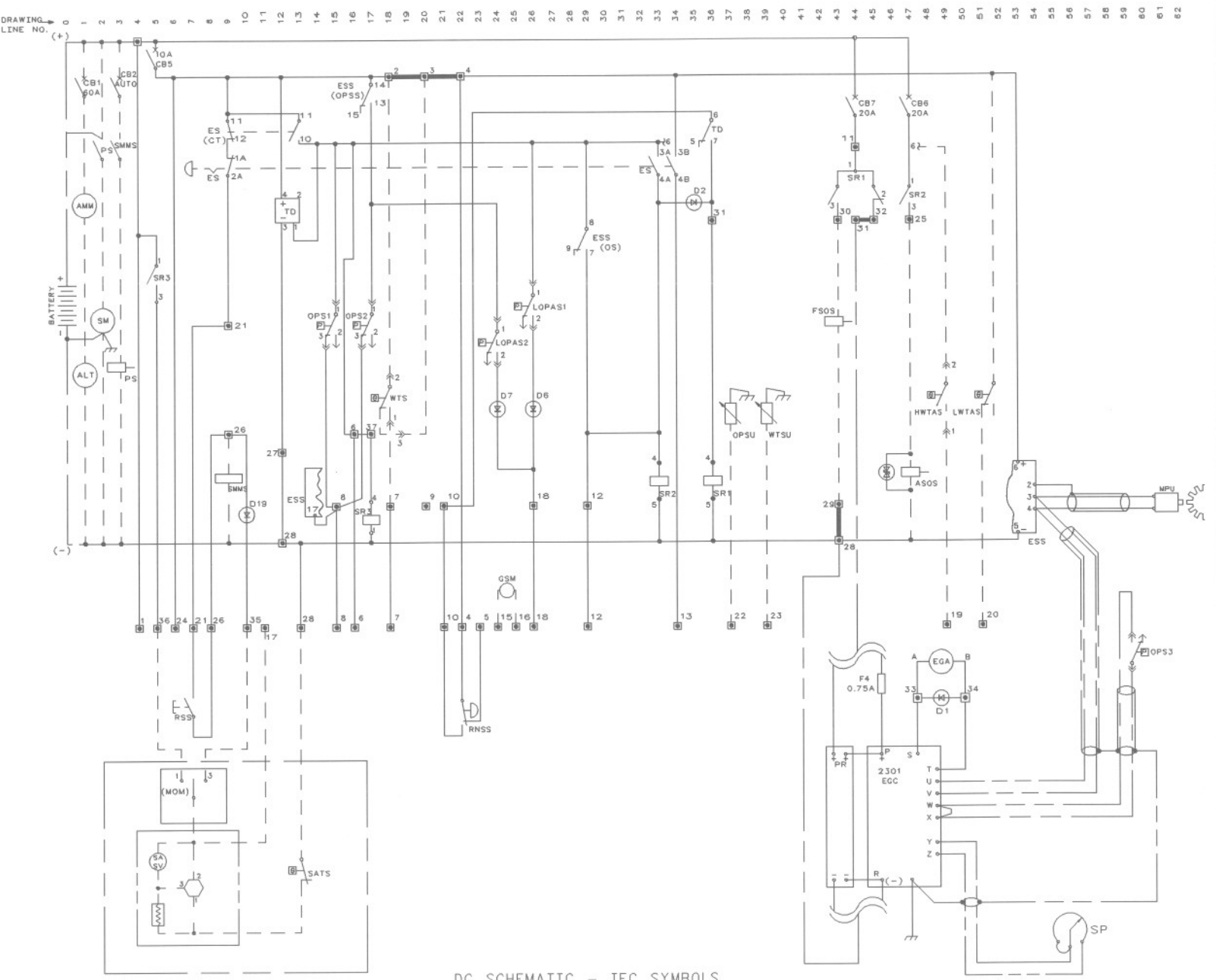

Illustration 31

JIC Schematic for ETS with OP, WT, and OS that requires a switchgear for use on 3500 Engines



DC SCHEMATIC - IEC SYMBOLS

Illustration 32
IEC Schematic for ETS with OP, WT, and OS that requires a switchgear for use on 3500 Engines

g00292527

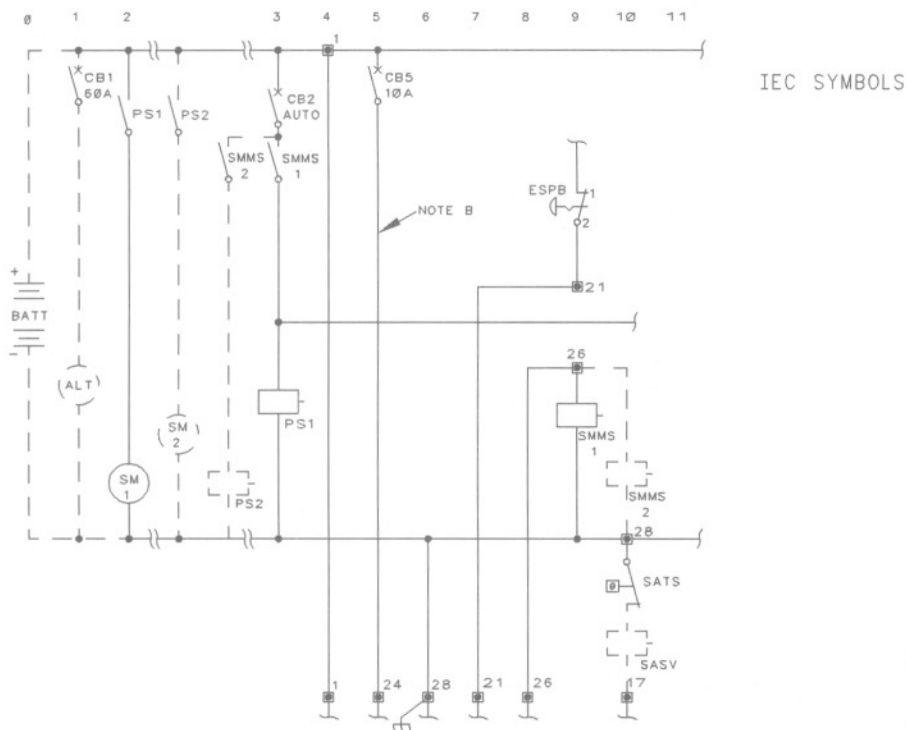

NOTE A: FOR COMPLETE SCHEMATIC REFER TO JUNCTION BOX WIRING DIAGRAM
NOTE B: WIRE ONLY PROVIDED ON ENERGIZED TO SHUTOFF (ETS) ENGINES

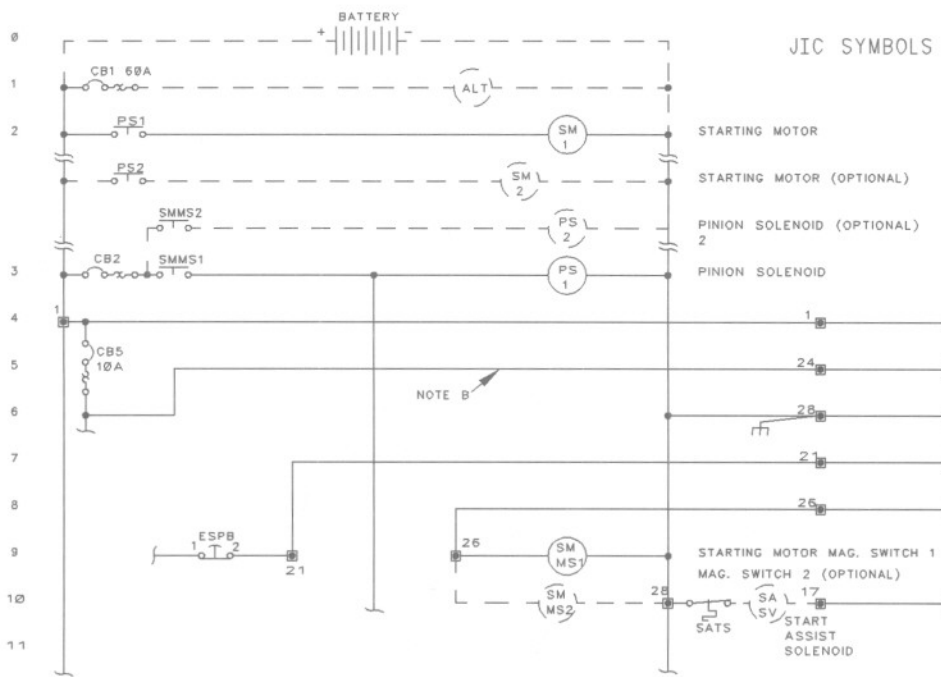
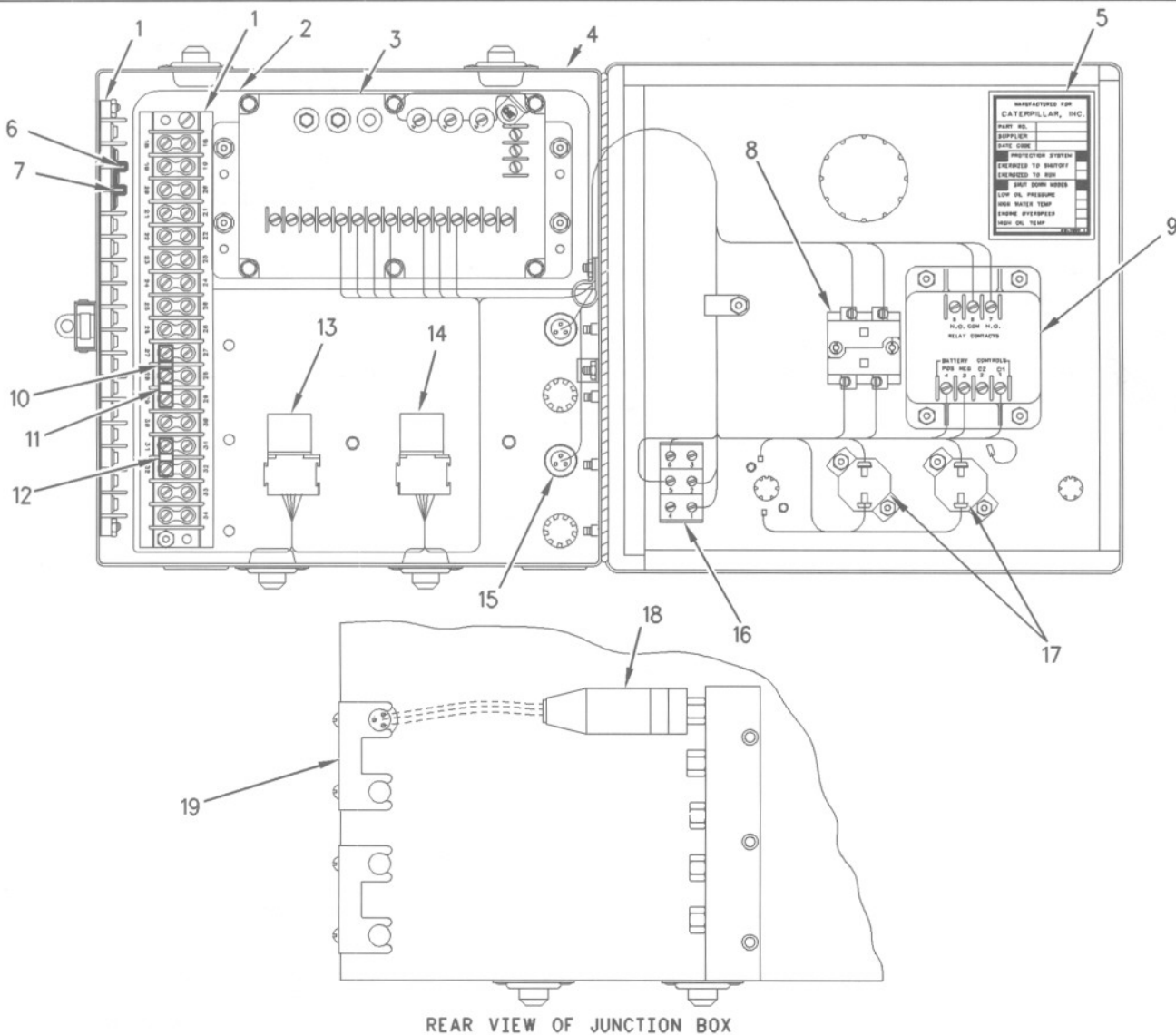

Illustration 34
IEC and JIC Schematics of dual starting motors (if equipped)

i01072018

ETS Junction Box-Switchgear Not Required (OP,WT,OS)

SMCS Code: 7400



REAR VIEW OF JUNCTION BOX

Illustration 36

g00567869

ETS Junction Box with oil pressure protection (OP), water temperature protection (WT), and overspeed protection (OS) that does not require a switchgear for use on 3200 through 3400 Engines

- | | | |
|--|---|--|
| (1) Terminal strips (TS) | (8) Emergency stop switch (ES) | (14) Slave relay (SR2) for the air shutoff solenoid (ASOS) (if equipped) |
| (2) Wiring harness | (9) Time delay relay (TD) | (15) Grommet assembly for engine oil pressure switches |
| (3) Electronic speed switch (ESS) | (10) Jumper between terminals (TS-27) and (TS-28) | (16) Start/stop switch (SSS) |
| (4) Junction box | (11) Jumper between terminals (TS-28) and (TS-29) | (17) Circuit breakers |
| (5) Identification foil | (12) Jumper between terminals (TS-30) and (TS-31) | (18) Engine oil pressure switch (OPS1) |
| (6) Jumper between terminals (TS-2) and (TS-3) | (13) Slave relay (SR1) | (19) Mounting brackets for grommet assemblies |
| (7) Jumper between terminals (TS-3) and (TS-4) | | |

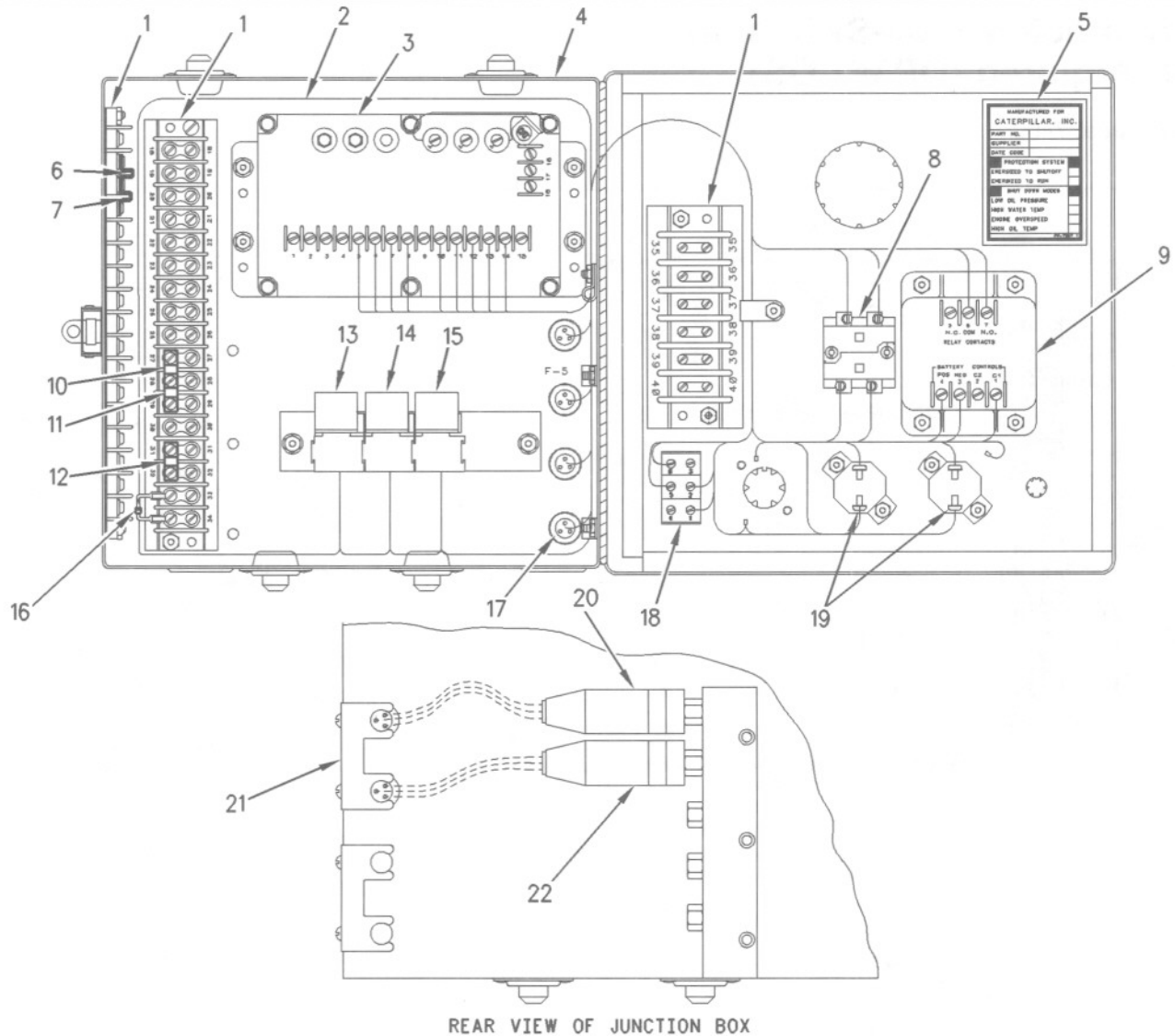

REAR VIEW OF JUNCTION BOX

Illustration 37

g00290530

ETS Junction Box with oil pressure protection (OP), water temperature protection (WT), and overspeed protection (OS) that does not require a switchgear for use on 3500 Engines

- | | | |
|--|--|---|
| (1) Terminal strips (TS) | (10) Jumper between terminals (TS-27) and (TS-28) | (16) Diode for electric governor actuator (if equipped) |
| (2) Wiring harness | (11) Jumper between terminals (TS-28) and (TS-29) | (17) Grommet assembly for engine oil pressure switches |
| (3) Electronic speed switch (ESS) | (12) Jumper between terminals (TS-30) and (TS-31) | (18) Start/stop switch (SSS) |
| (4) Junction box | (13) Slave relay (SR1) | (19) Circuit breakers |
| (5) Identification foil | (14) Slave relay (SR2) for the air shutoff solenoid (ASOS) (if equipped) | (20) Engine oil pressure switch (OPS1) |
| (6) Jumper between terminals (TS-2) and (TS-3) | (15) Slave relay (SR3) for starting aid switch (if equipped) | (21) Mounting brackets for grommet assemblies |
| (7) Jumper between terminals (TS-3) and (TS-4) | | (22) Engine oil pressure switch (OPS2) (if equipped) |
| (8) Emergency stop switch (ES) | | |
| (9) Time delay relay (TD) | | |

Introduction

The ETS Junction Box with oil pressure protection (OP), water temperature protection (WT), and overspeed protection (OS) that does not require a switchgear is a system that has full protection. The system has a junction box arrangement that is designed to monitor four functions:

- Engine overspeed
- Crank termination
- Oil pressure
- Coolant temperature

The junction box includes the following components:

- Electronic speed switch (ESS) (2)
- Start/stop switch (SSS) (18) and (16)
- Slave relay (SR1) (13)
- Slave relay (SR2) (if equipped) with an air shutoff solenoid (ASOS) (14)
- Oil pressure switch (OPS1) (18) and (20)
- Oil pressure switch (OPS2) that is only in 3500 Engines (22)
- Emergency stop switch (ES) (8)
- Time delay relay (TD) (9)

The components that are listed below operate with the junction box. The components are also mounted on the engine.

- Fuel shutoff solenoid (FSOS)
- Air shutoff solenoid (ASOS)
- Water temperature switch (WTS)

The following components must remain de-energized in order for the engine to run with the ETS electric protection system.

- Slave relay (SR1)
- Slave relay (SR2) (if equipped)
- Fuel solenoid (FS)
- Air shutoff solenoid (ASOS)

Electrical Schematics And Wiring Diagrams

This manual contains the point-to-point wiring diagrams for the complete electric protection system and the junction box. Four types of electrical schematics for each electric protection system arrangement are shown in this service manual.

- Junction box wiring diagram
- IEC (International Electro-Technical Commission) schematic
- JIC (Joint Industrial Council) schematic
- Junction box wiring harness diagram

Note: The line number that follows a component code gives the location of the component on the IEC and JIC schematics.

Circuit Operation With No Faults

Engine Shutdown

When the engine is stopped, power is always available across the terminals (ESS-5) and (ESS-6) (line 53) of the electronic speed switch (ESS). Power is also available across terminals (TD-3) and (TD-4) (line 12) of the time delay relay (TD). All of the switches are in the normally open position or the normally closed positions at that time.

Engine Start-up

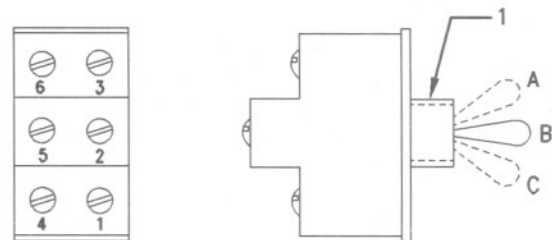

Illustration 38

g00282739

5N-0364 Switch for 3500 Engines only

(1) Keyway

Table 4

Switch Position	Contacts that are Closed
START (A)	1-2 and 4-5
RUN (B)	2-3 and 4-5
STOP (C)	2-3 and 5-6

A toggle switch is located on the front of the junction box. The switch is spring loaded and the toggle switch is automatically returned to the RUN position. This happens when the toggle is manually released from the START position. This start/stop switch (SSS) has three positions:

- START (A)
- RUN (B)
- STOP (C)

When the start/stop switch is moved to the START position, the following events should occur in the electric circuit.

1. The start/stop switch closes the circuit to the starter motor.
2. The starter motor magnetic switch (SMMS) (line 9) closes a contact (line 3) which energizes the pinion solenoid (PS) (line 3).
3. The PS closes a contact (line 2) which energizes the starter motor (SM).

When the toggle of the start/stop switch is held in the START position, power is always available to the starter motor until the engine begins to run. When the engine begins to run, the crank terminate switch (CT) stops the current that runs to the starter motor. When the engine begins to run, move the start/stop switch to the RUN position. If the engine oil pressure is too low to open the oil pressure switch (OPS1), the contacts across terminals (OPS1-1) and (OPS1-3) (line 15) open after the 9 second time limit. The slave relay (SR1) (line 36) is energized and the engine will shut down. Refer to "Fault Circuit Operation" for the complete circuit description under these conditions.

Note: If an electric starting motor and an alternator are not used on the engine, connect the power source to the engine. Connect the positive lead of the power source to terminal (TS-1) and connect the negative lead to terminal (TS-28) of the junction box. If an electric starting motor is not used and an alternator is used, the battery can still be used to run the engine. Connect the battery cables to the studs for the power input which are located on the bottom of the power distribution box.

Engine Mounted Start Switch (EMSS)

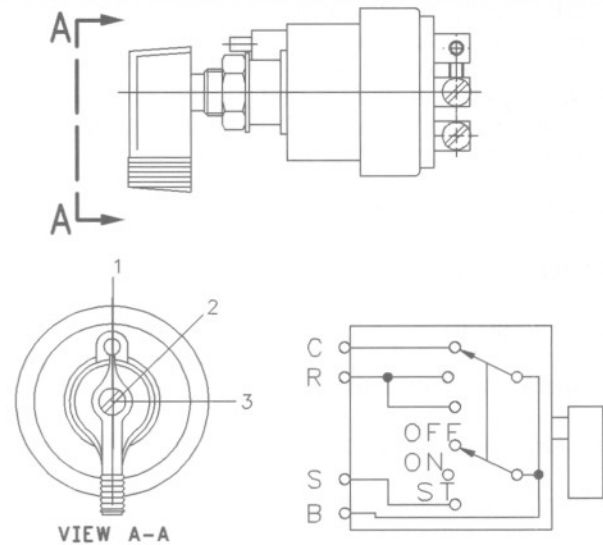

Illustration 39

g00281973

Engine mounted start/stop switch (typical example)

(1) OFF position with switch terminals (B) and (C) closed. (2) ON position with switch terminals (B) and (R) closed. (3) START position with switch terminals (B), (R), and (S) closed.

Some engines use an engine mounted start switch (EMSS). The EMSS replaces the start/stop switch (SSS) and the contact for the starting motor magnetic switch (SMMS) (line 3). If an engine mounted start/stop switch is provided on the engine to control the electric starting motor, the start/stop switch (SSS) will not be installed in the junction box.

The EMSS is a start/stop switch which functions in the same manner as the SSS. When the lever of the EMSS moves to the START position, the pinion solenoid (PS) (line 3) is energized. The contacts (line 2) of the PS close. This energizes the starter motor (SM). The lever of the EMSS must remain in the START position until the engine begins to run before releasing the switch lever.

Engine Operation

When the engine starts to run and the speed setting of the crank termination is reached, the crank terminate switch stops the current to the starter motor circuit. The starter motor will stop even if the start/stop switch (SSS) is held in the START position. The crank terminate switch is located in the electronic speed switch. When crank termination is reached, the following events occur in the electric circuit.

1. The contacts for the crank terminate switch open across terminals (ESS-11) and (ESS-12) (line 9). The contacts across terminals (ESS-10) and (ESS-11) (line 13) close.
2. When the contacts of the CT open across terminals (ESS-11) and (ESS-12), the current flow is stopped to the starter motor circuit and the starter motor (SM) will stop.
3. The other contacts of the CT close across terminals (ESS-11) and (ESS-10) in order to energize "Control 2" at terminal (TD-2) of the time delay relay (TD) (line 13).
4. After 9 seconds, the TD closes contacts across terminals (TD-6) and (TD-7) (line 36) in order to arm the shutoff circuit to the slave relay (SR1) (line 36).
5. When the engine oil pressure increases enough to make the contacts of the engine oil pressure switch (OPS1) (line 15) open across the terminals (OPS1-1) and (OPS1-3) and close across the terminals (OPS1-1) and (OPS1-2), "Control 1" at terminal (TD-1) of the time delay relay will be energized.
6. When "Control 1" is energized, the contacts across terminals (TD-6) and (TD-7) (line 36) will close. This arms the shutoff circuit to (SR1).

Both "Control 1" and "Control 2" must be energized in order for the engine to continue running.

3500 Engines Running At A Rated Speed

When the oil pressure step switch (OPSS) (line 17) is closed across terminals (ESS-14) and (ESS-13) and oil pressure switch (OPS2) (line 17) is open across contacts (OPS2-1), no current flow to the slave relay (SR1) (line 36) exists. The switches will remain in these positions and the engine will continue to run under the following conditions:

- No engine problems exist.
- The engine is running at a rated speed.
- The engine is running at a speed above the oil step speed setting, which is optional.

(OPS2) (line 17) will not open across contacts (OPS2-1) and (OPS2-3) until the oil pressure increases to the rating of the switch (OPS2) for a particular engine. After (OPS2) is open, the switch will not close until the oil pressure has dropped approximately 35 kPa (5 psi) below the pressure rating that opened the switch.

The oil pressure step switch (OPSS) is not controlled by engine oil pressure. The OPSS (line 17) is controlled by the engine speed.

The speed setting of the oil pressure step switch is adjustable. The OPSS is energized when the oil pressure is equal to the speed setting of the OPSS or greater than the speed setting of the OPSS. However, the oil pressure step switch has a 9 second delay before the switch can close across terminals (ESS-14) and (ESS-13). This delay provides the time that is needed for the engine oil pressure to increase in order to open the switch (OPS2). The system could constantly activate engine shutdown without the time delay.

3500 Engines Running At A Speed Below The Oil Step Speed Setting

If the engine continues to run at a speed below the oil step speed setting, the oil pressure step switch (OPSS) (line 17) remains open. The OPSS will not complete the circuit in order to shut down the engine when the switch (OPS2) (line 17) is closed across the contacts (OPS2-1) and (OPS2-3).

If the engine oil pressure increases enough to open the switch (OPS1) (line 15) across contacts (OPS1-1) and (OPS1-3), the engine can safely run at this speed. The oil pressure circuit will not cause shutdown.

If the engine accelerates through the oil step speed setting, the circuit might remain in the same state that is described above. When the engine speed is equal to the setting of the OPSS or greater than the setting of the OPSS, the engine oil pressure must be greater than the rated speed for (OPS2). This will open (OPS2) (line 17) within the 9 second time delay that is needed for the oil pressure step switch (OPSS) to remain open. If the engine oil pressure is not greater than the rated speed for (OPS2), the following events may occur:

1. The OPSS (line 17) will close across contacts (ESS-14) and (ESS-13) after 9 seconds.
2. Engine shutdown will occur if (OPS2) remains closed across the contacts (OPS2-1) and (OPS2-3).
3. The (OPS2) cannot open before the OPSS closes. The engine will continue to run.

Normal Stop Switch

The engine is stopped by moving the start/stop switch. The switch is moved from the RUN position to the STOP position.

The following events occur in the electric circuit when the start/stop switch is moved to the STOP position.

1. The start/stop switch closes across contacts (SSS-5) and (SSS-6) in order to energize the time delay relay (TD) (line 36).
2. The current then flows through contacts (TD-6) and (TD-7) (line 36) of the time delay relay (TD).
3. Current through the TD energizes slave relay (SR1) (line 36) which closes across contacts (SR1-30) and (SR1-87) (line 43).
4. When slave relay (SR1) (line 36) is energized, the fuel shutoff solenoid (FSOS) (line 43) is also energized, and the fuel flow to the engine is stopped.
5. When the engine stops, the crank terminate switch (CT) closes across terminals (ESS-11) and (ESS-12) (line 9), which allows the engine to restart.

The engine can now be restarted.

Emergency Stop Switch

The push button of the emergency stop switch is located on the front of the junction box door. The push button is red and the push button has a round shape. When this push button is depressed, the switch is in the OFF position which shuts down the engine. The push button will remain depressed until the push button is manually released to the ON position. The engine cannot be restarted if the push button is depressed.

When the push button is depressed, the following events occur in the electric circuit in order to stop the engine.

1. An open circuit is made across contacts (ES-1A) and (ES-2A) (line 9).
2. A closed circuit is made across the contacts (ES-3A) and (ES-4A) (line 33) which energizes the slave relays (SR1) (line 36) and (SR2) (line 33).
3. When (SR2) is energized, and if (SR2) is equipped with an air shutoff solenoid, the circuit closes across the contacts (SR2-30) and (SR2-87) (line 47) in order to energize the air shutoff solenoid (ASOS).
4. This effectively stops the inlet air to the engine. The ASOS remains energized until the contacts (ESS-10) and (ESS-11) (line 13) of the CT switch open. The contacts will open after the engine stops.
5. The slave relay (SR1) (line 36) is energized when the circuit closes across the contacts (ES-3A) and (ES-4A).
6. The current then flows through the diode (D2) (line 35). This causes (SR1) to close the contacts (SR1-30) and (SR1-87) (line 43). These contacts are normally open.
7. When (SR1) energizes, the fuel shutoff solenoid (FSOS) is also energized. This stops the fuel flow to the engine.

WARNING

Accidental engine starting can cause injury or death to personnel working on the equipment.

To avoid accidental engine starting, disconnect the battery cable from the negative (-) battery terminal. Completely tape all metal surfaces of the disconnected battery cable end in order to prevent contact with other metal surfaces which could activate the engine electrical system.

Place a Do Not Operate tag at the Start/Stop switch location to inform personnel that the equipment is being worked on.

In order to start the engine again, perform the following procedures.

1. Correct any faults that might cause the emergency shutdown.
2. Manually reset the air shutoff lever which is located at the top of the air inlet housing.
3. Make sure that the push button of the emergency stop switch has been reset on the junction box of the engine. Turn the push button in the direction that is shown on the face of the push button in order to reset the button. The push button moves outward in order to reset.
4. Move and hold the toggle of the start/stop switch in the START position in order to restart the engine. If the engine is equipped with an engine mounted start switch, the lever of the switch must be in the START position in order to restart the engine.

Fault Circuit Operation

Oil Pressure Fault ("OPS1")

When the engine starts and the engine begins to run, the crank terminate switch (CT) opens. This arms the electric protection system. The following events occur in the electric circuit in order to arm the electric protection system.

1. The CT switch opens across the terminals (ESS-11) and (ESS-12) (line 9). The switch closes across terminals (ESS-11) and (ESS-10) (line 13).
2. The CT switch arms the electric protection system when a current is sent to "Control 2" at terminal (TD-2) of the time delay relay (line 13).

The engine oil pressure switch (OPS1) (line 15) must open within 9 seconds after the electric protection system is armed. The engine oil pressure must increase to the rating that is necessary to open (OPS1). The following events occur in the electric circuit if (OPS1) does not open across contacts (OPS1-1) and (OPS1-2).

1. The contacts of the time delay relay (TD) will close across terminals (TD-6) and (TD-7) (line 36). This energizes the slave relay (SR1) (line 36).
2. The current then flows through the contacts (OPS1-1) and OPS1-3 to terminal (ESS-17) through the diode (D4) (line 17).
3. The current flows through the jumper between (TS-9) and (TS-10) (line 21).
4. The current flows through contacts (TD-6) and (TD-7). This energizes the slave relay (SR1).
5. Slave relay (SR1) opens across the contacts (SR1-30) and (SR1-87a) (line 45). The relay closes across the contacts (SR1-30) and (SR1-87) (line 43).
6. When (SR1) energizes, the fuel shutoff solenoid (FSOS) (line 43) is also energized. This stops the fuel flow to the engine.

The electric protection system will cause engine shutdown in the same way that is described in the previous paragraph if the engine is running under the following conditions:

- No faults
- A speed that is less than the oil step speed setting

- The engine oil pressure falls below the minimum pressure rating of the oil pressure switch.

The (OPS1) closes across the contacts (OPS1-1) and (OPS1-3) (line 15) when the oil pressure decreases to the minimum pressure rating, which causes immediate engine shutdown.

NOTICE

To avoid possible engine damage or another immediate shutdown, the engine oil pressure fault must be corrected before attempting to restart the engine.

The oil step latch is only used on 3500 Series Engines. The oil step latch is energized at terminal (ESS-17) by the events that are described above. The contacts (ESS-11) and (ESS-12) of the crank terminate switch (CT) open. The contacts remain open until 2 seconds after the engine speed can no longer be detected. An attempt to start the engine will be cancelled until two seconds after the flywheel rotation has stopped.

NOTICE

To avoid possible damage to the starter motor pinion and the engine flywheel ring gear, do not attempt to restart the engine until the engine rotation has completely stopped.

 **WARNING**

Accidental engine starting can cause injury or death to personnel working on the equipment.

To avoid accidental engine starting, disconnect the battery cable from the negative (-) battery terminal. Completely tape all metal surfaces of the disconnected battery cable end in order to prevent contact with other metal surfaces which could activate the engine electrical system.

Place a Do Not Operate tag at the Start/Stop switch location to inform personnel that the equipment is being worked on.

Oil Pressure Fault (OPS2) (3500 Engines) Only

A fault occurs in the high pressure side of the oil pressure circuit when the engine is running at a speed above the oil step speed setting. A fault also occurs when the engine oil pressure falls below the pressure setting of (OPS2). The oil step speed setting is adjustable.

When the engine is running at a speed that is above the oil step speed setting, the electric current will follow the same path that is described in the "Oil Pressure Fault (OPS1)" section of this manual. However, the oil pressure step switch (OPSS) is closed across contacts (ESS-14) and (ESS-13) (line 13). Also, the oil pressure switch (OPS2) is closed across contacts (OPS2-1) and (OPS2-2). The OPSS switch is already closed because the engine has been running at a speed above the step oil pressure setting.

When the engine oil pressure decreases below the high pressure rating of (OPS2), the following events occur in the electric circuit in order to stop the engine.

1. The engine oil pressure switch (OPS2) opens across contacts (OPS2-1) and (OPS2-2) and the engine oil pressure switch closes across (OPS2-1) and (OPS2-3).
2. The voltage drop across terminal (ESS-17) causes the contacts (OPSS-13) and (OPSS-14) of the OPSS to close. The contacts will remain closed for two seconds after the engine speed can not be detected.
3. The current then flows through diode (D4) (line 17) and the current also flows through the jumper across the terminals (TS-9) and (TS-10) (line 20).
4. The current flows through the contacts (TD-6) and (TD-7) (line 36) of the time delay relay which energizes the slave relay (SR1) (line 43).
5. When (SR1) is energized, the switch opens across contacts (SR1-30) and (SR1-87a) (line 45). The switch closes across contacts (SR1-30) and (SR1-87) (line 43).
6. The energized (SR1) energizes the fuel shutoff solenoid (FSOS) (line 43) which stops the fuel flow to the engine.

NOTICE

To avoid possible engine damage or another immediate shutdown, the engine oil pressure fault must be corrected before attempting to restart the engine.

WARNING

Accidental engine starting can cause injury or death to personnel working on the equipment.

To avoid accidental engine starting, disconnect the battery cable from the negative (-) battery terminal. Completely tape all metal surfaces of the disconnected battery cable end in order to prevent contact with other metal surfaces which could activate the engine electrical system.

Place a Do Not Operate tag at the Start/Stop switch location to inform personnel that the equipment is being worked on.

Engine Overspeed (OS)

When the engine speed increases above the overspeed setting of the electronic speed switch, the overspeed switch (OS) will cause engine shutdown. The following events occur in the electric circuit in order to shut down the engine.

1. When the overspeed occurs, the ESS closes across the terminals (ESS-8) and (ESS-7) (line 29).
2. The current flows from the battery to the crank terminate switch (CT) and across the terminals (ESS-11) and (ESS-10) (line 13).
3. The current flows through the overspeed switch (OS) and to the slave relay (SR2) (line 33). If the overspeed switch (OS) is equipped with an air shutoff solenoid, the solenoid becomes energized.
4. The (SR2) closes across the contacts (SR2-30) and (SR2-87) (line 47) in order to activate the air shutoff solenoid (ASOS), if equipped.
5. The current flows through the diode (D2) (line 35) to the slave relay (SR1) (line 36) which becomes energized.
6. The (SR1) opens across the contacts (SR1-30) and (SR1-87a) (line 45). The (SR1) closes across the contacts (SR1-30) and (SR1-87) (line 43).
7. When (SR1) energizes, the fuel shutoff solenoid (FSOS) (line 43) becomes energized.
8. When the fuel shutoff solenoid (FSOS) (line 43) is energized, the fuel flow is stopped to the engine.

A reset button on the electronic speed switch must be pushed in order to open the overspeed switch. The air shutoff lever must be manually reset to the open position before the engine can be restarted. The air shutoff lever is located at the top of the air inlet housing.

 **WARNING**

Accidental engine starting can cause injury or death to personnel working on the equipment.

To avoid accidental engine starting, disconnect the battery cable from the negative (-) battery terminal. Completely tape all metal surfaces of the disconnected battery cable end in order to prevent contact with other metal surfaces which could activate the engine electrical system.

Place a Do Not Operate tag at the Start/Stop switch location to inform personnel that the equipment is being worked on.

Water Temperature Fault

The current flow for the circuit that is described in this section is applicable for all engines. The engine must be running at a speed with a coolant temperature that is hot enough to close the water temperature contactor switch (WTS). The water temperature contactor switch is normally open. The following events occur in the electric circuit in order to shut down the engine. The engine will shut down when the temperature of the coolant system is greater than the maximum temperature that is set for the WTS.

1. When the WTS closes, the current flows across the terminals (TS-2) and (TS-7) (line 18).
2. Current flows through the diode (D3) (line 19) and through the jumper between (TS-9) and (TS-10) (line 21).
3. The current flows through the contacts (TD-6) and (TD-7) (line 36) of the time delay relay in order to energize the slave relay (SR1) (line 36).
4. When the (SR1) is energized, the switch closes across contacts (SR1-30) and (SR1-87) (line 43).
5. When the (SR1) is energized, the fuel shutoff solenoid (FSOS) (line 43) also becomes energized. This stops the fuel flow to the engine.

NOTICE

To avoid possible engine damage or another immediate shutdown, the water temperature fault must be corrected before attempting to restart the engine.

Even though the starter motor circuit can now be engaged, there is no fuel flow to the engine. The fuel flow to the engine is stopped until the coolant temperature falls below the rating for the water temperature contactor switch (WTS). When the coolant temperature falls below the rating for the water temperature contactor switch (WTS), the contactor switch opens again. The fuel shutoff solenoid is de-energized when the switch reopens. This allows fuel flow to the engine. The engine can then be restarted.

2301A Electric Governor Control

The 2301A Electric Governor Control activates all of the components that are in the electric protection system. The components are activated in the same manner when the nonelectric governor is used. One difference exists in the main circuit. The fuel shutoff solenoid (FSOS) (line 43) is not used.

When the electric governor control is used, the engine must run in a normal condition in order for the electric circuit to operate in the manner that is described below.

1. Current flows from the terminals (TS-28) (line 43) and (TS-31) (line 44), which are located on the terminal strip in the junction box.
2. Current from terminals (TS-28) (line 43) and (TS-31) (line 44) flows through the preregulator (PR) (line 48) or the fuse (F4) to the electric governor control.
3. When the engine flywheel is rotating, the current also flows through the electric governor actuator (EGA) (line 52).

When a fault in the system causes the current to energize the slave relay (SR1), the following events occur in the electric circuit in order to stop the engine.

1. The slave relay (SR1) opens across the contacts (SR1-30) and (SR1-87a) (line 45). The relay closes across the contacts (SR1-30) and (SR1-87) (line 43).
2. When the circuit opens across contacts (SR1-30) and (SR1-87a), the current is stopped to the electric governor control.
3. Current to the electric governor actuator (EGA) is also stopped.
4. The mechanical spring load in the electric governor actuator (EGA) will now move the fuel control rod in order to stop fuel flow to the engine.

Note: With the exception of the differences that are described in this section of the manual, all of the fault circuits in the electric protection system are identical for the 2301A Electric Governor Control and for the nonelectric governor control.

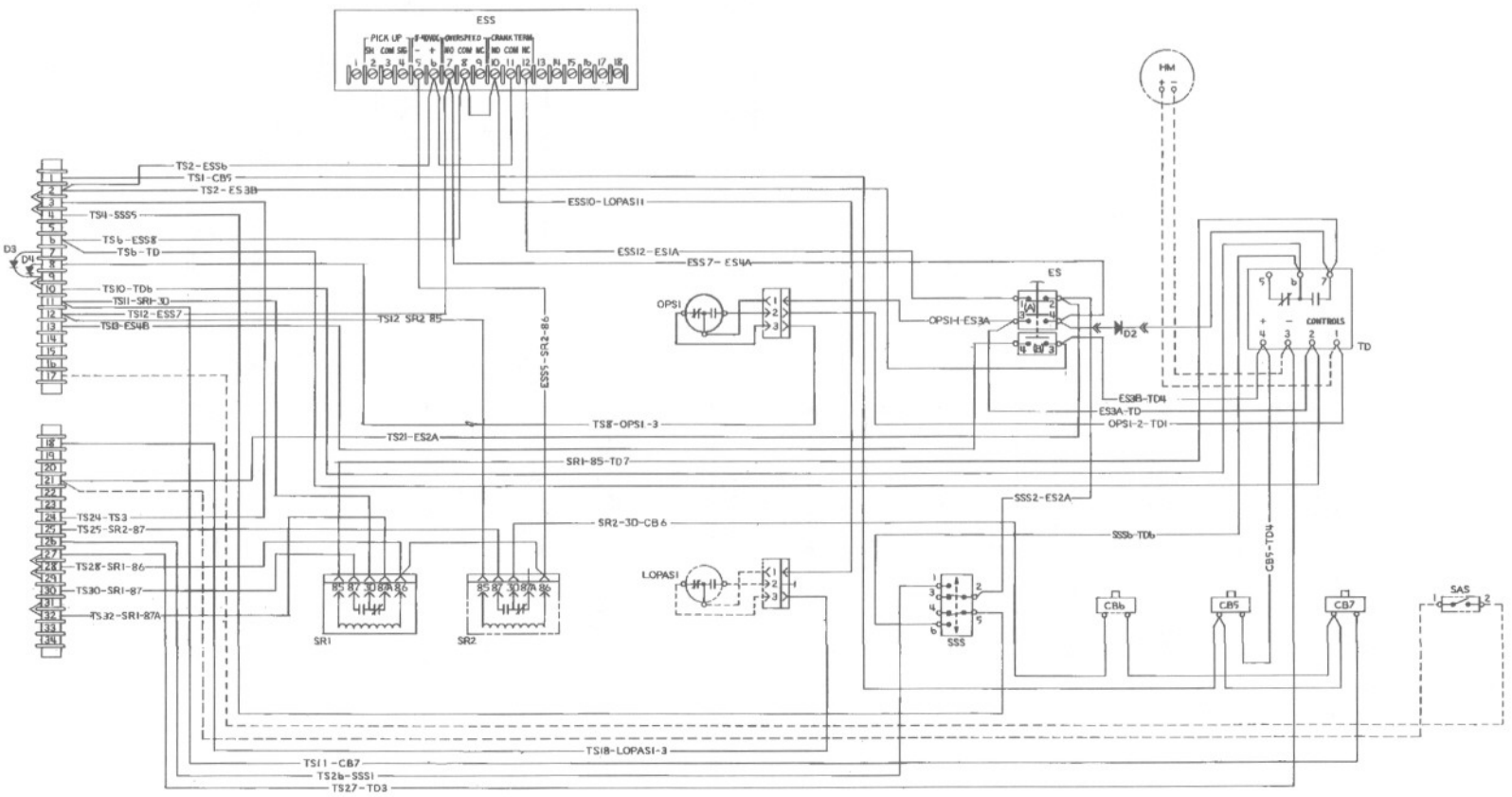

Illustration 40
Junction Box Wiring for ETS with OP, WT, and OS that does not require a switchgear for use on 3200 through 3400 Engines

900292456

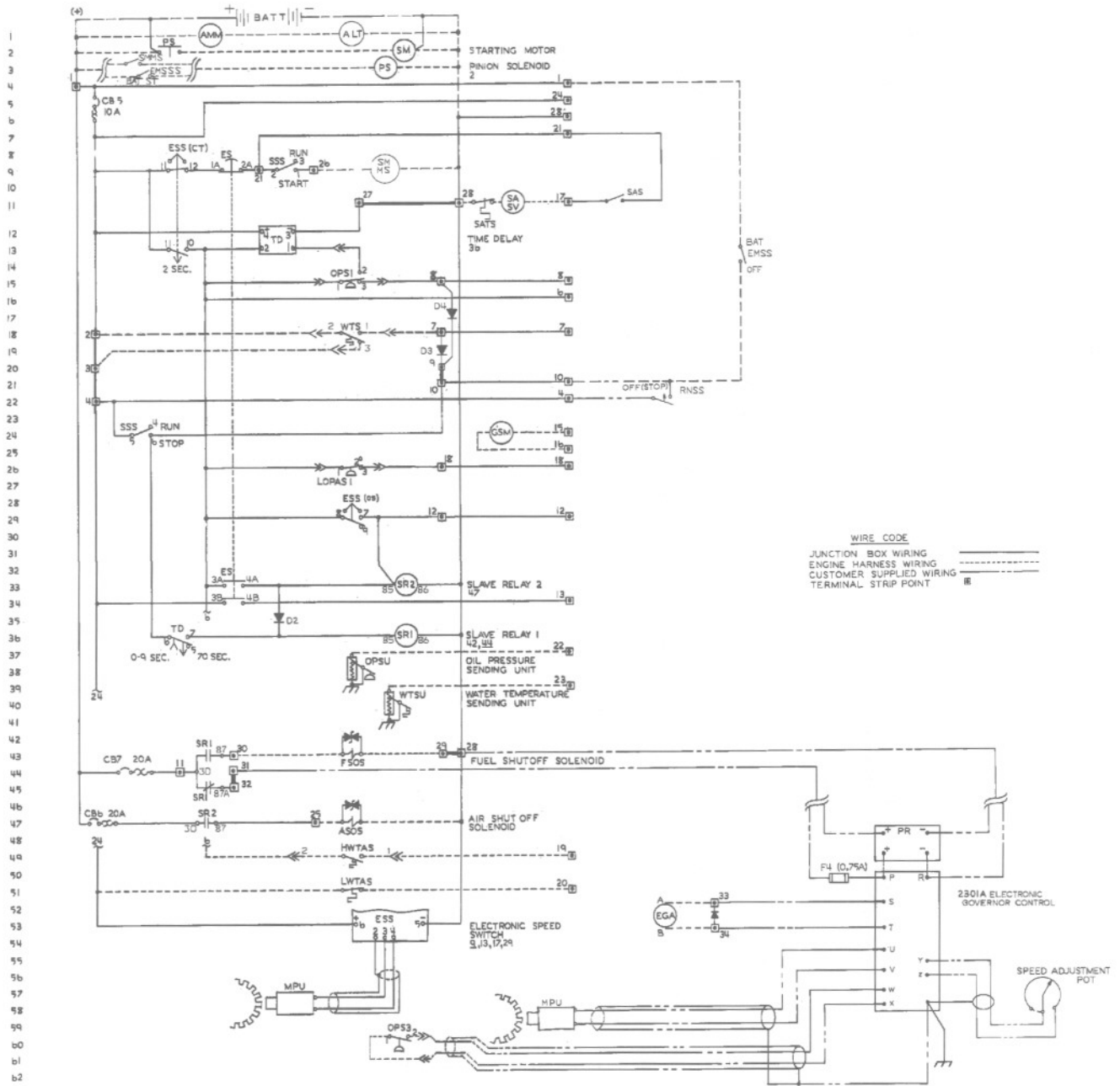
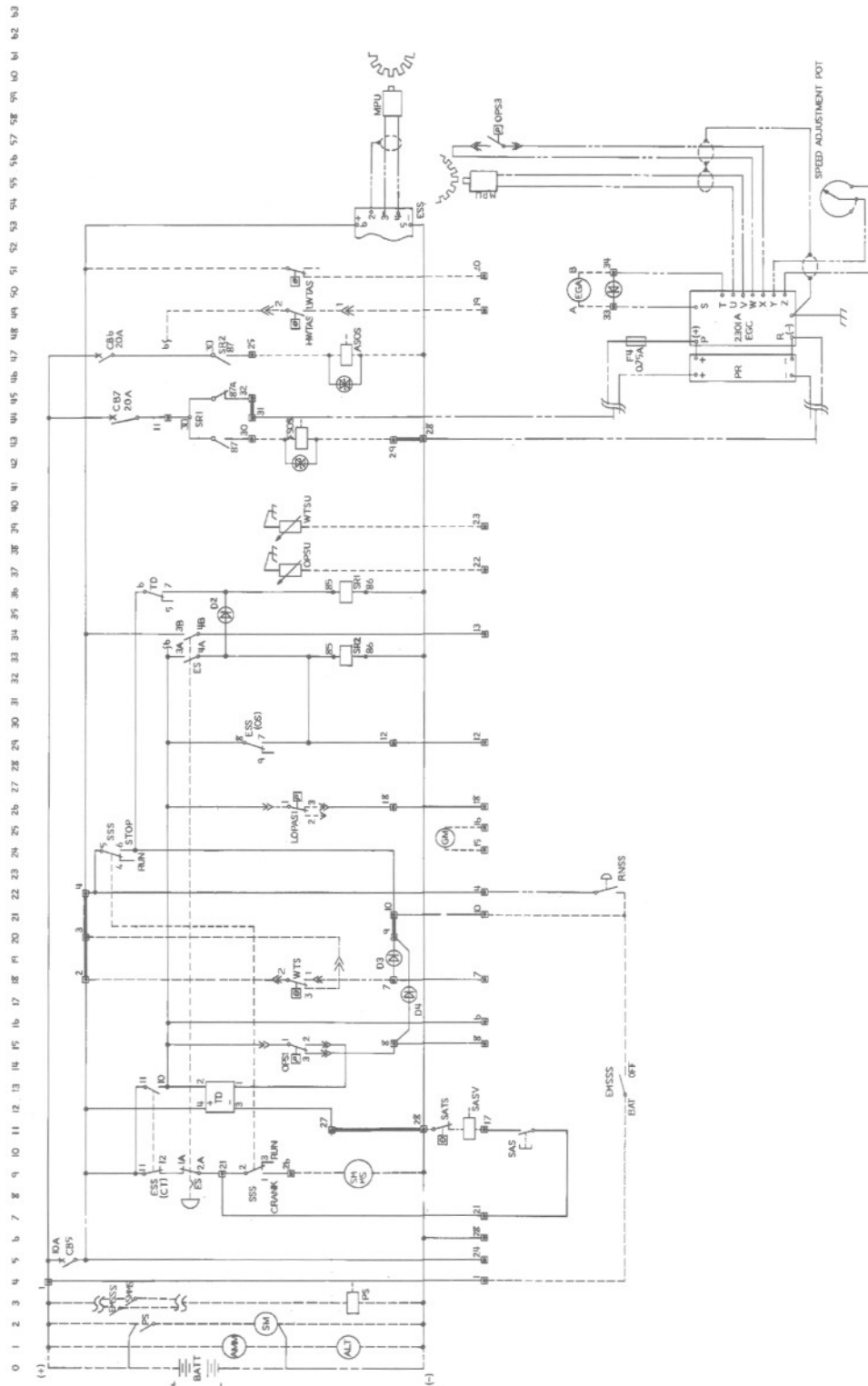

Illustration 41

g00292457

JIC Schematic for ETS with OP, WT, and OS that does not require a switchgear for use on 3200 through 3400 Engines



DC SCHEMATIC - IEC SYMBOLS

Illustration 42

IEC Schematic for ETS with OP, WT, and OS that does not require a switchgear for use on 3200 through 3400 Engines

TERMINATION	TERM ITEM NO	GA	LENGTH REF	COLOR IDENT	ITEM NO.	TERM ITEM NO.	TERMINATION	TERMINATION	TERM ITEM NO	GA	LENGTH REF	COLOR IDENT	ITEM NO.	TERM ITEM NO.	TERMINATION
CB5	8	14	203	TAN	1	8	CB7	TS2	8	14	1054	TAN	1	8	ES3B
CB5	8	14	173	TAN	1	8	TD4	TS2	7	18	622	TAN	2	10	ESS6
CB6	8	14	266	TAN	1	8	CB7	TS4	7	18	1064	TAN	2	10	SS55
D2	7	18	163	TAN	2	7	TD7	TS6	7	18	1145	TAN	2	7	TD
ES3A	7	18	440	TAN	2	7	TD	TS6	7	18	660	TAN	2	10	ESS8
ES3B	8	14	171	TAN	1	8	TD4	TS8	7	18	797	TAN	2	13	OPSI-3
ES4A	7	18	202	TAN	2	5	D2	TS10	7	18	1141	TAN	2	7	TD6
ESS5	10	18	368	GN/YL	3	-	SR2-86	TS11	8	14	1320	TAN	1	8	CB7
ESS6	10	18	134	TAN	2	10	ESS11	TS11	8	14	297	TAN	1	8	SRI-30
ESS7	10	18	656	TAN	2	7	ES4A	TS12	7	18	753	TAN	2	10	ESS7
ESS8	10	18	107	TAN	2	10	ESS10	TS12	7	18	363	TAN	2	9	SR2-85
ESS10	10	18	450	TAN	2	12	LOPASI-1	TS13	7	18	1194	TAN	2	7	ES4B
ESS12	10	18	585	TAN	2	7	ES1A	TS16	7	18	772	TAN	2	13	LOPASI-3
OPSI-1	12	18	617	TAN	2	7	ES3A	TS21	7	18	992	TAN	2	7	ES2A
OPSI-2	13	18	828	TAN	2	7	TD1	TS24	8	14	113	TAN	1	8	TS3
SRI-86	-	18	152	GN/YL	3	9	SR2-86	TS25	8	14	412	TAN	1	9	SR2-87
SRI-85	9	18	907	TAN	2	7	TD7	TS26	7	18	1119	TAN	2	10	SSS1
SR2-30	9	14	855	TAN	1	8	CB5	TS27	7	18	1240	GN/YL	3	7	TD3
SSS2	10	18	350	TAN	2	7	ES2A	TS28	7	18	290	GN/YL	3	9	SRI-86
SSS6	10	18	402	TAN	2	7	TD6	TS30	8	14	262	TAN	1	9	SRI-87
TS1	8	14	1097	TAN	1	8	CB5	TS32	8	14	234	TAN	1	9	SRI-87A

ITEM	QTY	MEAS UNIT	PART NO.	NAME
PARTS LIST				
1	65	dm	5P-4704	WIRE
2	165	dm	5P-9078	WIRE
3	21	dm	6V-8242	WIRE
4	1		2W-4899	DIODE AS.
5	1		8N-1610	TERMINAL
6	1		9C-3186	TERMINAL
7	30		5P-1475	TERMINAL
8	21		7T-6364	TERMINAL
9	9		5P-3059	TERMINAL
10	15		15-9593	STRAP
B11	70		7N-7780	PIN
12	2		7N-7779	SOCKET
13	3		9C-3695	PLUG
14	1		9C-3662	GROMMET
15	2		7N-7782	HOUSING
C17	2	dm	5P-1038	TUBE

Illustration 43
61 - 1862 Wiring Harness for ETS with OP, WT, and OS that does not require a switchgear for use on 3200 through 3400 Engines

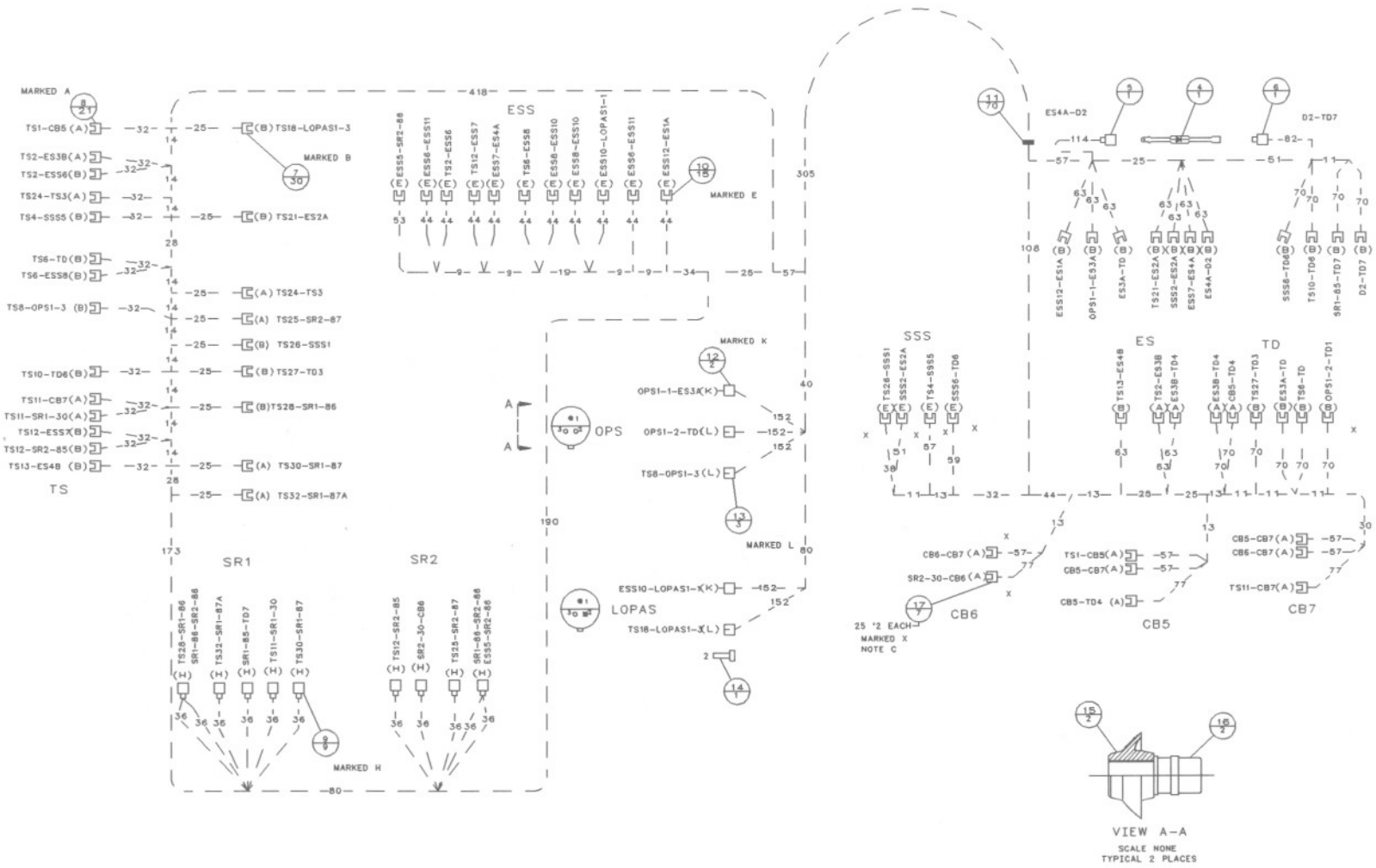

900292474

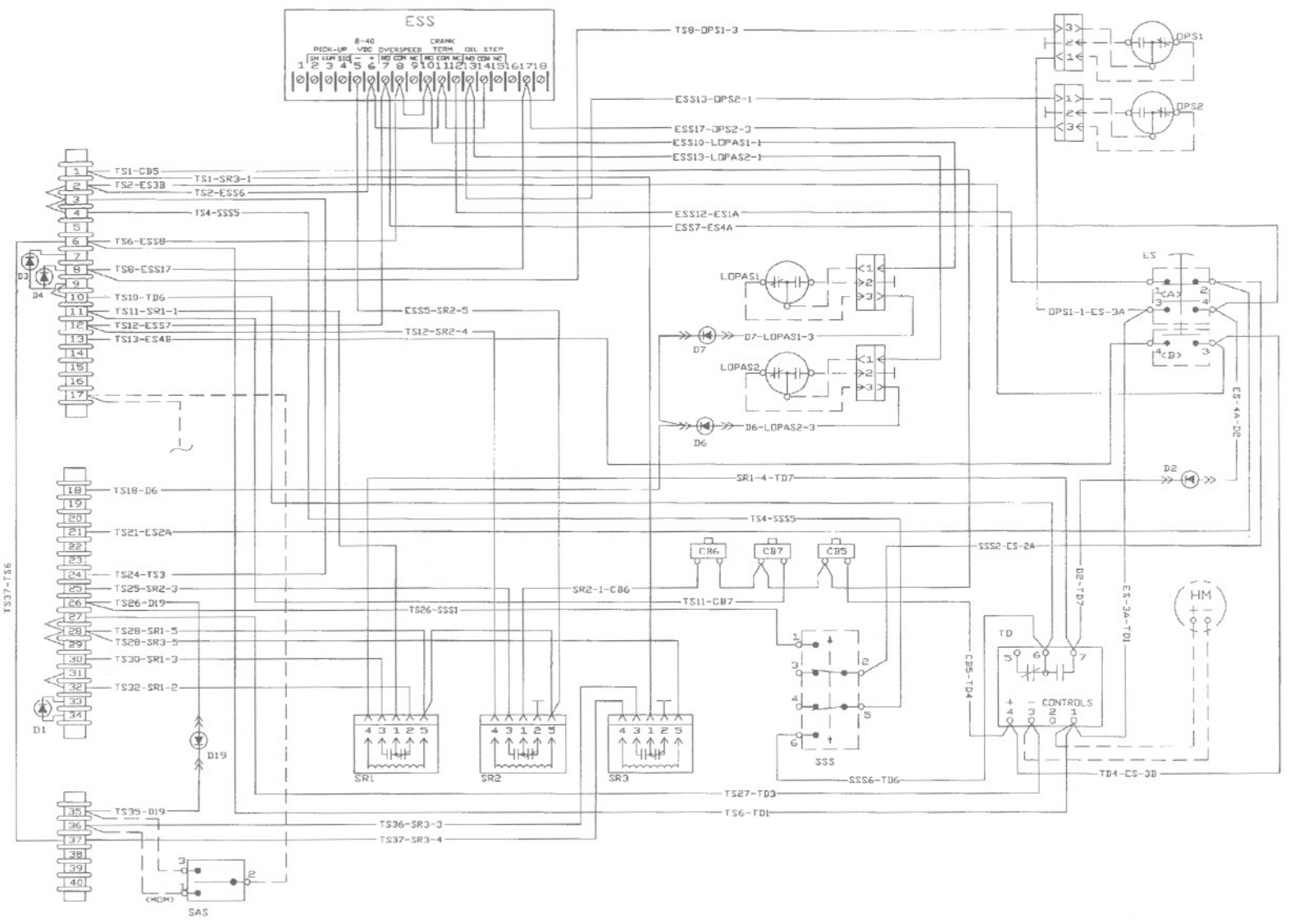

Illustration 44
 Junction Box Wiring for ETS with OP, WT, and OS that does not require a switchgear for use on 3500 Engines

900292459

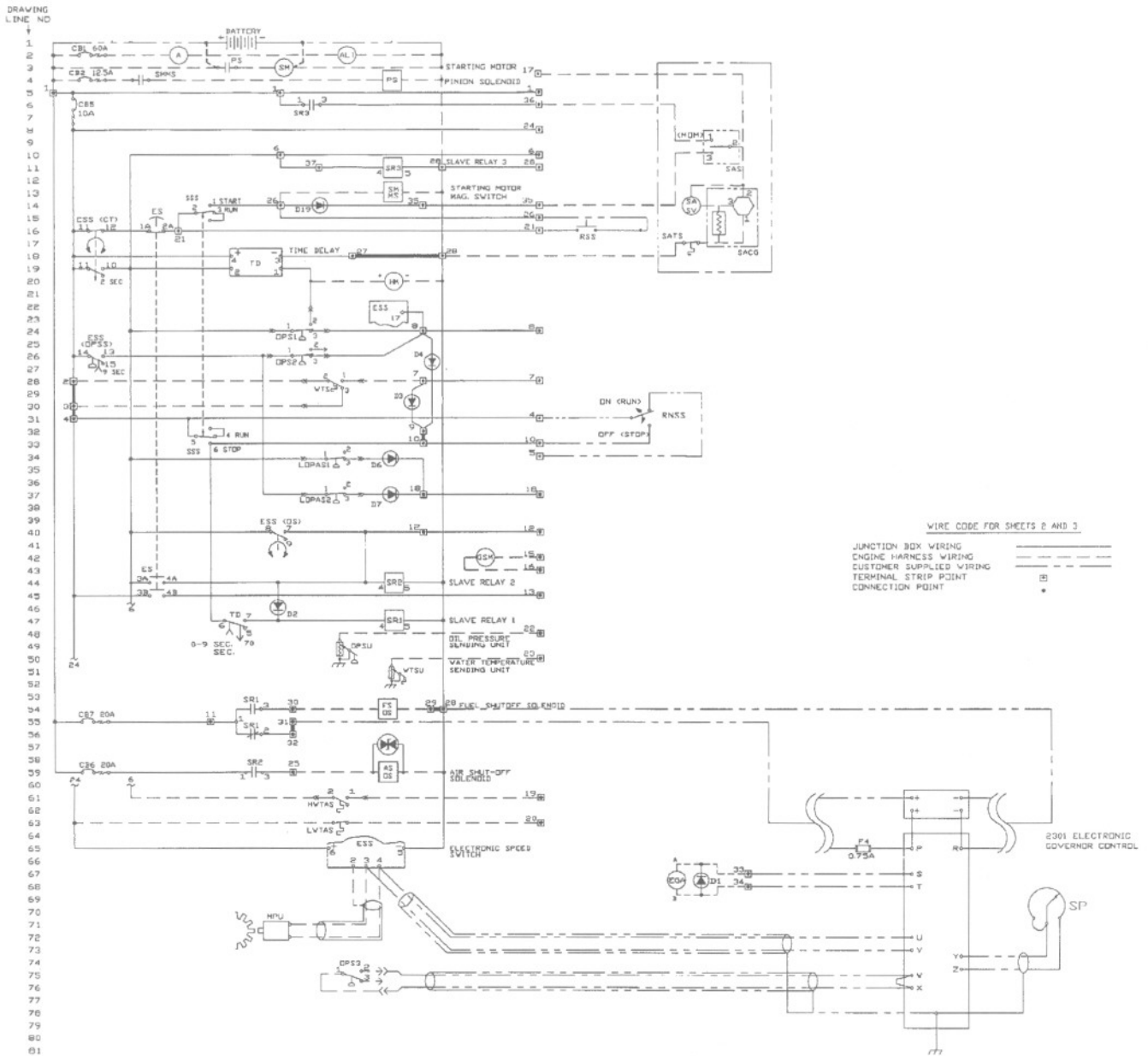
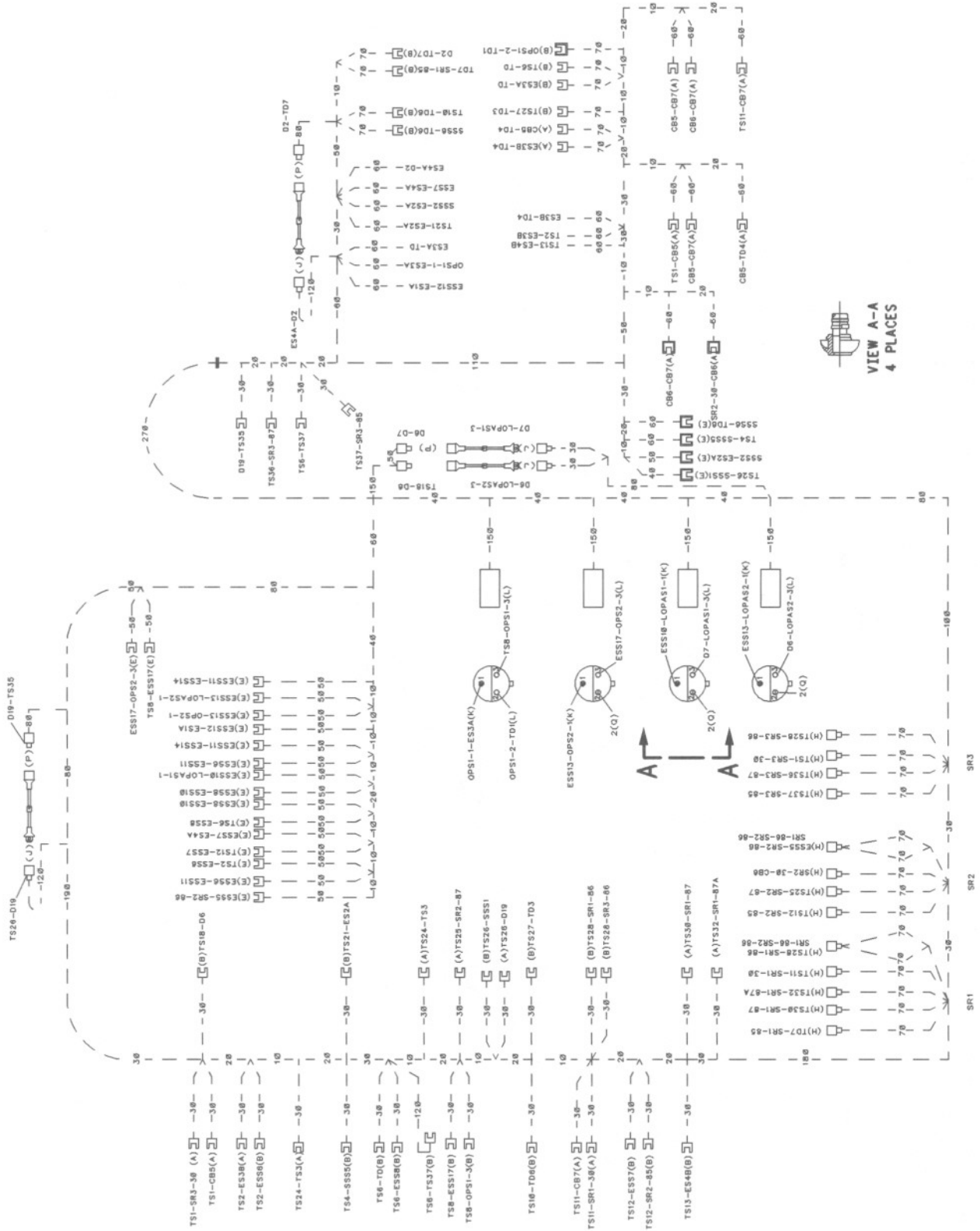

Illustration 45

g00292460

JIC Schematic for ETS with OP, WT, and OS that does not require a switchgear for use on 3500 Engines



VIEW A-A
4 PLACES

Illustration 47

100-3638 Wiring Harness for ETS with OP, WT, and OS that does not require a switchgear for use on 3500 Engines

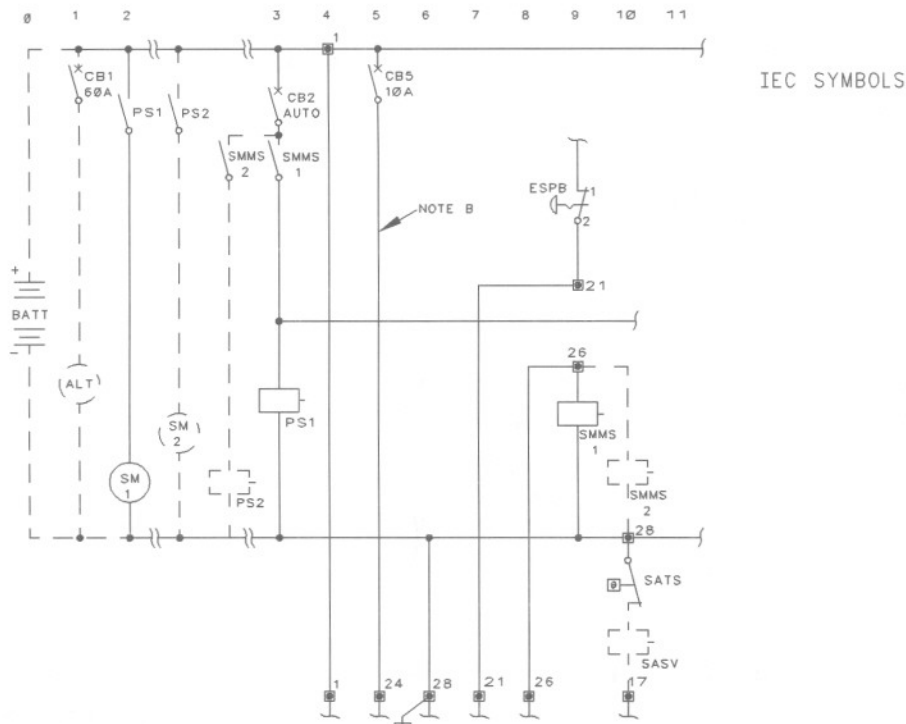

NOTE A: FOR COMPLETE SCHEMATIC REFER TO JUNCTION BOX WIRING DIAGRAM

NOTE B: WIRE ONLY PROVIDED ON ENERGIZED TO SHUTOFF (ETS) ENGINES

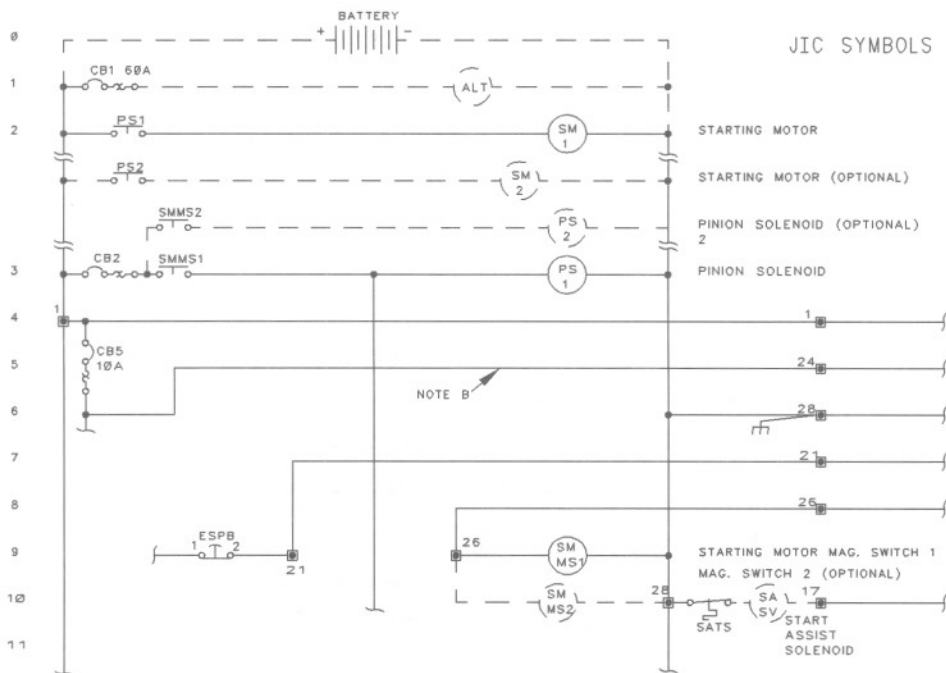

Illustration 48
IEC and JIC Schematics of dual starting motors (if equipped)

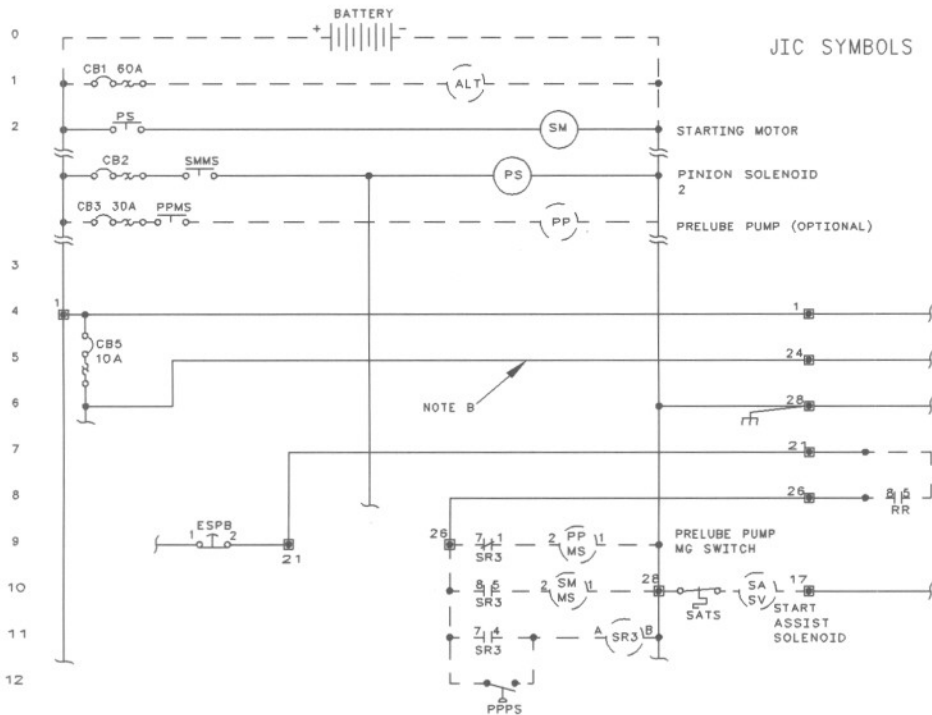
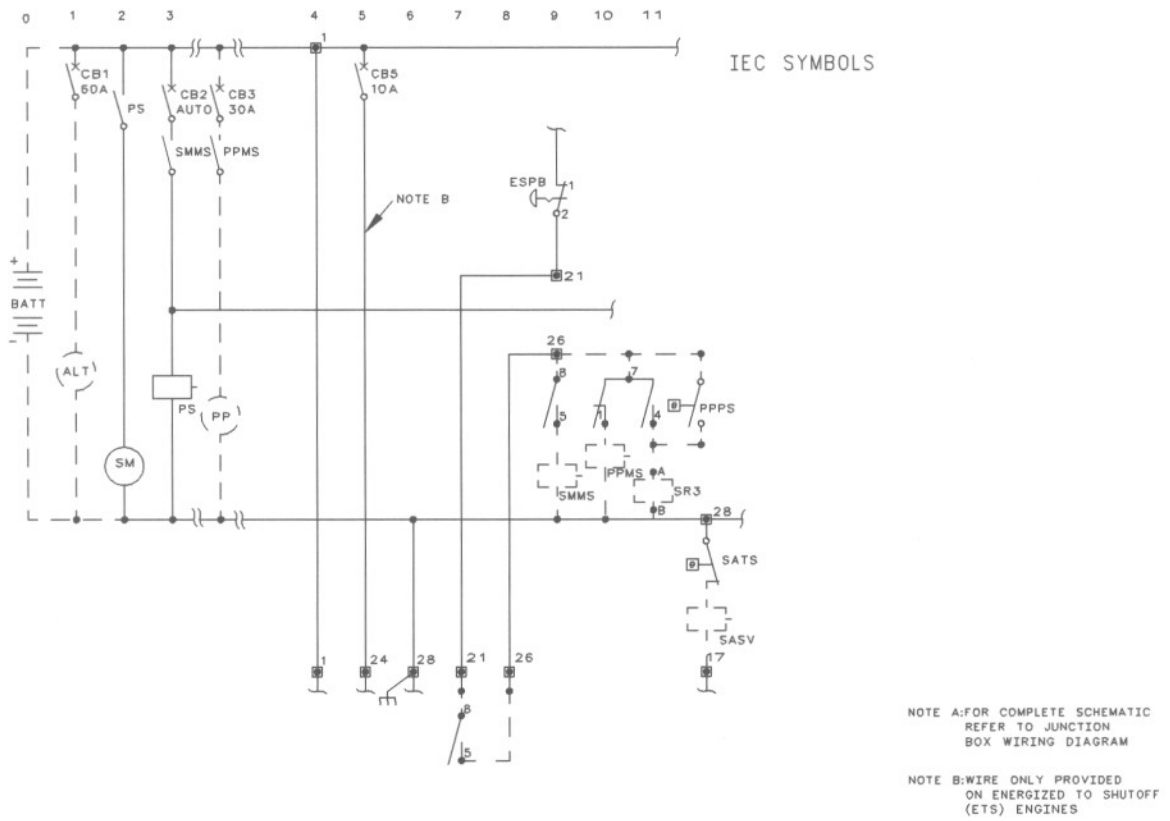
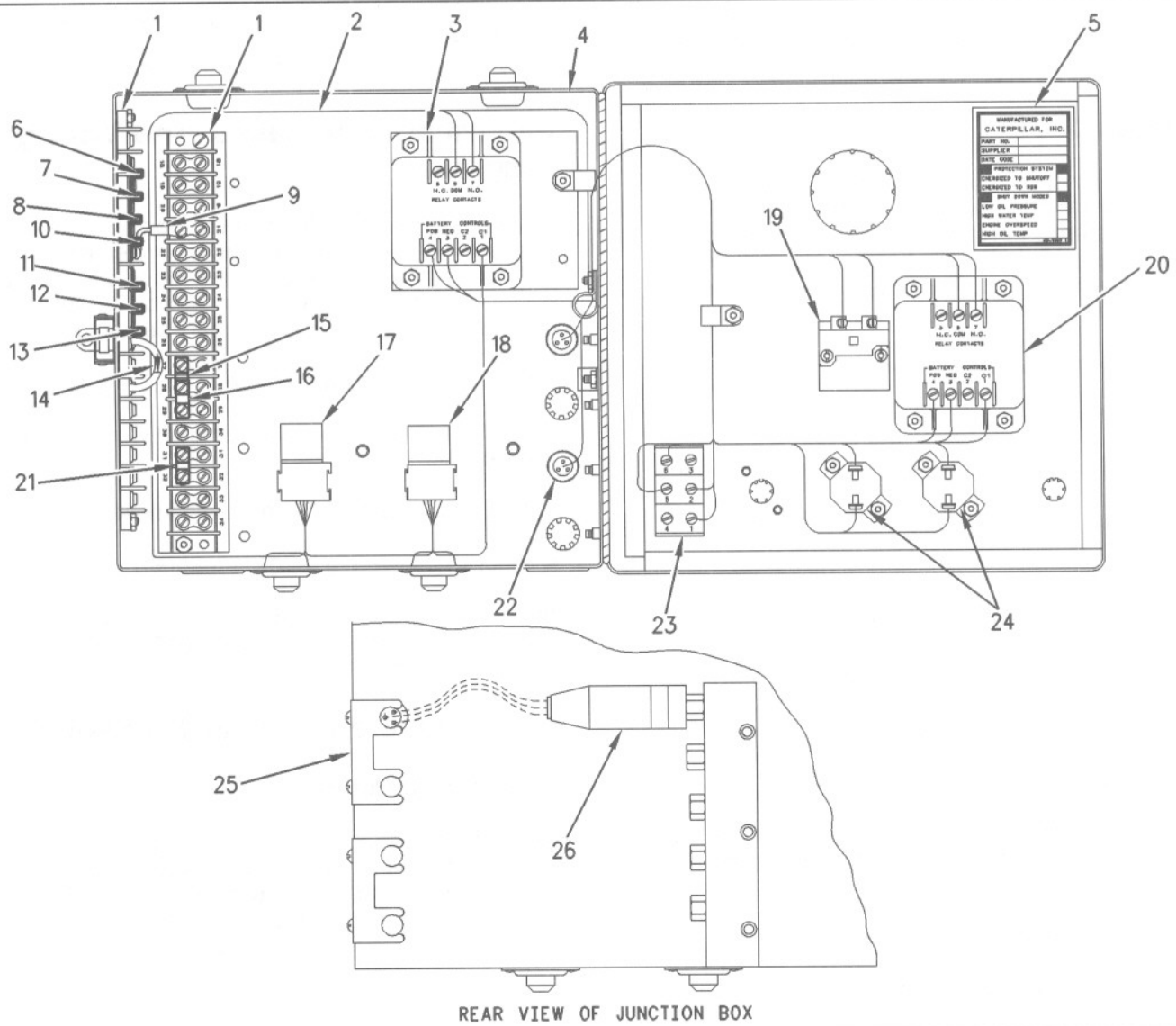

Illustration 49
IEC and JIC Schematics for a prelude pump (if equipped)

i01071804

ETS Junction Box-Switchgear Not Required (OP,WT)

SMCS Code: 7400



REAR VIEW OF JUNCTION BOX

Illustration 50

g00291265

ETS Junction Box with oil pressure protection (OP) and water temperature protection (WT) that does not require a switchgear for use on 3200 through 3400 Engines

- | | | |
|---|---|---|
| (1) Terminal strips (TS) | (10) Jumper between terminals (TS-5) and (TS-6) | (17) Slave relay (SR1) |
| (2) Wiring harness | (11) Jumper between terminals (TS-7) and (TS-8) | (18) Slave relay (SR2) |
| (3) Time delay relay (TD2) | (12) Jumper between terminals (TS-8) and (TS-9) | (19) Emergency stop switch (ES) |
| (4) Junction box | (13) Jumper between terminals (TS-9) and (TS-10) | (20) Time delay relay (TD1) |
| (5) Identification foil | (14) Diode (D1) | (21) Jumper between terminals (TS-31) and (TS-32) |
| (6) Jumper between terminals (TS-2) and (TS-3) | (15) Jumper between terminals (TS-27) and (TS-28) | (22) Grommets for engine oil pressure switches |
| (7) Jumper between terminals (TS-3) and (TS-4) | (16) Jumper between terminals (TS-28) and (TS-29) | (23) Start/stop switch (SSS) |
| (8) Jumper between terminals (TS-4) and (TS-5) | | (24) Circuit breakers |
| (9) Jumper between terminals (TS-6) and (TS-21) | | (25) Mounting brackets for grommet assemblies |
| | | (26) Engine oil pressure switch (OPS1) |

Introduction

The ETS Junction Box with oil pressure protection (OP) and water temperature protection (WT) is a partial protection system that does not require a switchgear. This system has a junction box arrangement which is designed to monitor two functions:

- Engine oil pressure
- Coolant temperature

The junction box includes the following components:

- start/stop switch (SSS) (23)
- Slave relay (SR1) (17)
- Oil pressure switch (OPS1) (26)
- Emergency stop switch (ES) (19)
- Time delay relay (TD1) (20)
- Time delay relay (TD2) (3)

The components that are listed below operate with the junction box. The components are also mounted on the engine.

- Fuel shutoff solenoid (FSOS)
- Water temperature contactor switch (WTS)

The following components must remain de-energized in order for the engine to run with the ETS electric protection system.

- Slave relay (SR1)
- Fuel solenoid (FS)

An air shutoff solenoid is not used because the engine overspeed is not monitored.

Electrical Schematics And Wiring Diagrams

This manual contains the point-to-point wiring diagrams for the complete electric protection system and the junction box. Four types of electrical schematics for each electric protection system arrangement are shown in this service manual.

- Junction box wiring diagram
- IEC (International Electro-Technical Commission) schematic
- JIC (Joint Industrial Council) schematic
- Junction box wiring harness diagram

Note: The line number that follows a component code gives the location of the component on the IEC and JIC schematics.

Circuit Operation With No Faults

Engine Shutdown

When the engine is stopped, power is always available across the terminals (TD1-3) and (TD1-4) (line 11) of the time delay relay (TD1). All of the switches are in the normally open position or the normally closed positions at that time.

Engine Start-up

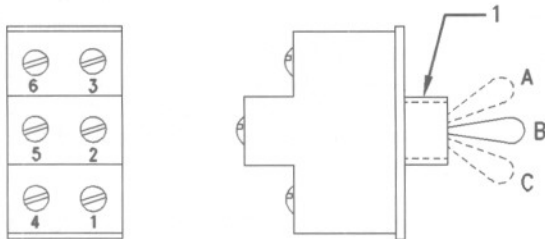

Illustration 51

g00282739

5N-0364 Switch

(1) Keyway

Table 5

Switch Position	Contacts that are closed
START (A)	1-2 and 4-5
RUN (B)	2-3 and 4-5
STOP (C)	2-3 and 5-6

A toggle switch is located on the front of the junction box. The switch is spring loaded and the toggle switch is automatically returned to the RUN position. This happens when the toggle is manually released from the START. This start/stop switch ("SSS") has three positions:

- START (A)
- RUN (B)
- STOP (C)

When the start/stop switch is moved to the START position, the following events should occur in the electric circuit.

1. The start/stop switch closes the circuit to the starter motor.
2. The starter motor magnetic switch (SMMS) (line 7) closes a contact (line 2) which energizes the pinion solenoid (PS) (line 2).
3. The PS closes a contact (line 1) which energizes the starter motor (SM).

When the toggle of the start/stop switch is held in the START position, power is always available to the starter motor until the engine begins to run. When the engine begins to run, move the start/stop switch to the RUN position. If the engine oil pressure is too low to open the oil pressure switch (OPS1), the contacts across terminals (OPS1-1) and (OPS1-3) (line 15) open after the 9 second time limit. The slave relay (SR1) (line 36) is energized and the engine will shut down. Refer to "Fault Circuit Operation" for the complete circuit description under these conditions.

Note: If an electric starting motor and an alternator are not used to run the engine, connect the power source to the engine. Connect the positive lead of the power source to terminal (TS-1) and connect the negative lead to terminal (TS-28) of the junction box. If an electric starting motor is not used and an alternator is used, the battery can still be used to run the engine. Connect the battery cables to the studs for the power input which are located on the bottom of the power distribution box.

Engine Mounted Start/Stop Switch (EMSS)

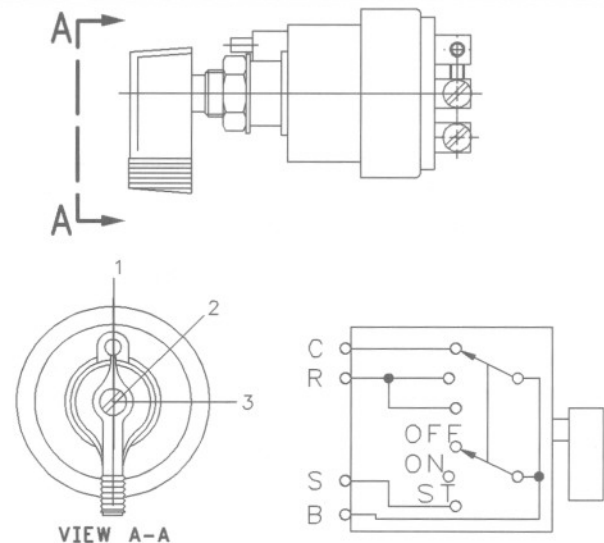

Illustration 52

g00281973

Engine mounted start/stop switch (typical example)

(1) OFF position with switch terminals (B) and (C) closed. (2) ON position with switch terminals (B) and (R) closed. (3) START position with switch terminals (B), (R), and (S) closed.

Some engines use an engine mounted start switch (EMSS). The EMSS replaces the start/stop switch (SSS) and the contact for the starting motor magnetic switch (SMMS) (line 2). If an engine mounted start/stop switch is provided on the engine to control the electric starting motor, the start/stop switch (SSS) will not be installed in the junction box.

The EMSS is a start/stop switch which functions in the same manner as the SSS. When the lever of the EMSS moves to the START position, the pinion solenoid (PS) (line 2) is energized. The contacts (line 1) of the PS close. This energizes the starter motor (SM). The lever of the EMSS must remain in the START position until the engine begins to run before releasing the switch lever.

Normal Stop Switch

The engine is stopped by moving the start/stop switch. The switch is moved from the RUN position to the STOP position.

The following events occur in the electric circuit when the start/stop switch is moved to the STOP position.

1. The start/stop switch closes across contacts (SSS-5) and (SSS-6) in order to energize the time delay relay (TD) (line 24).
2. The current then flows through contacts (TD1-6) and (TD1-7) (line 32) of the time delay relay (TD).
3. Current through the TD energizes slave relay (SR1) which closes across contacts (SR1-30) and (SR1-87) (line 34).
4. When slave relay (SR1) is energized, the fuel shutoff solenoid (FSOS) is also energized, and the fuel flow to the engine is stopped.

The following events occur in the electric circuit when the SSS is moved to the START position.

1. The circuit is broken to "Control 1" of the time delay relay (TD1) (line 12).
2. When the power is removed from terminal (TD1-1) a timer keeps the switch closed for 70 seconds across contacts (TD1-6) and (TD1-7). This delay ensures that the engine is completely stopped before the contacts can open.
3. When the circuit across contacts (TD1-6) and (TD1-7) open the slave relay (SR1) is de-energized. This stops current to the fuel shutoff solenoid (FSOS).
4. When the FSOS is de-energized, fuel can flow to the engine.

NOTICE

To avoid possible damage to the starter motor pinion and the engine flywheel ring gear, do not attempt to restart the engine until the engine rotation has completely stopped.

Emergency Stop Switch (ES)

The push button of the emergency stop switch is located on the front of the junction box door. The push button is red and the push button has a round shape. When this push button is depressed, the switch is in the OFF position which shuts down the engine. The push button will remain depressed until the push button is manually released to the ON position. The engine cannot be restarted if the push button is depressed.

When the push button is depressed, the following events occur in the electric circuit in order to stop the engine.

1. An open circuit is made across contacts (ES-1A) and (ES-2A) (line 9).
2. The open circuit across contacts (ES-1) and (ES-2) stops the current flow to the circuit for the starting motor and to "Control 1" of the time delay relay (TD1).
3. A closed circuit is made across the contacts (ES-3A) and (ES-4A) (line 28). This causes the contacts across (TD1-6) and (TD1-7) of the TD (line 32) to close.
4. The slave relay (SR1) (line 34) is energized when the circuit closes across the contacts (ES-3A) and (ES-4A).
5. The current then flows through the diode (D2) (line 35). This causes (SR1) to close the contacts (SR1-30) and (SR1-87) (line 43). These contacts are normally open.
6. When (SR1) energizes, the fuel shutoff solenoid (FSOS) is also energized. This stops the fuel flow to the engine.

When the circuit is opened to "Control 1" of the time delay relay (TD), the circuit is closed across contacts (TD1-6) and (TD1-7) (line 32) for a period of 70 seconds. After 70 seconds, the switch will open across the contacts and the switch will de-energize the slave relay (SR1). This stops the flow of current to the fuel shutoff solenoid (FSOS) and fuel can flow to the engine.

⚠ WARNING

Accidental engine starting can cause injury or death to personnel working on the equipment.

To avoid accidental engine starting, disconnect the battery cable from the negative (-) battery terminal. Completely tape all metal surfaces of the disconnected battery cable end in order to prevent contact with other metal surfaces which could activate the engine electrical system.

Place a Do Not Operate tag at the Start/Stop switch location to inform personnel that the equipment is being worked on.

In order to start the engine again, perform the following procedures.

1. Correct any faults that might cause the emergency shutdown.
2. Make sure that the push button of the emergency stop switch has been reset on the junction box of the engine. Turn the push button in the direction that is shown on the face of the push button in order to reset the button. The push button moves outward in order to reset.
3. Move and hold the toggle of the start/stop switch in the START position in order to restart the engine. If the engine is equipped with an engine mounted start switch, the lever of the switch must be in the START position in order to restart the engine.

Fault Circuit Operation

Oil Pressure Fault (OPS1)

The process of arming the electric protection system is described in the "Engine Start-up" section.

If an oil pressure fault occurs, the following events occur in the electric circuit in order to stop the engine.

The engine oil pressure switch (OPS1) (line 15) must open within 9 seconds after the electric protection system is armed. The engine oil pressure must increase to the rating that is necessary to open (OPS1). The following events occur in the electric circuit if (OPS1) does not open across contacts (OPS1-1) and (OPS1-2).

1. The oil pressure must decrease enough after the system is armed in order for the oil pressure switch (OPS1) to close across the contacts (OPS1-1) and (OPS1-3) (line 14).

2. The current then flows to the terminal strip (TS-8) and through the diode (D1) (line 23).
3. The current flows through the time delay relay (TD1) (line 32). This energizes the slave relay (SR1).
4. Slave relay (SR1) opens across the contacts (SR1-30) and (SR1-87a) (line 45). The relay closes across the contacts (SR1-30) and (SR1-87) (line 43).
5. When (SR1) energizes, the fuel shutoff solenoid (FSOS) (line 43) is also energized. This stops the fuel flow to the engine.

The starter motor can be engaged and the engine can be cranked immediately after an engine shutdown is caused by a fault in the electric protection system. However, the engine cannot be restarted because the fuel flow remains stopped for 70 seconds after the fault activates the electric protection system. After 70 seconds, the switch in the time delay relay will open across the contacts (TD1-6) and (TD1-7) (line 32). This will disarm the system. The engine can then be restarted.

NOTICE

To avoid possible engine damage or another immediate shutdown, the engine oil pressure fault must be corrected before attempting to restart the engine.

⚠ WARNING

Accidental engine starting can cause injury or death to personnel working on the equipment.

To avoid accidental engine starting, disconnect the battery cable from the negative (-) battery terminal. Completely tape all metal surfaces of the disconnected battery cable end in order to prevent contact with other metal surfaces which could activate the engine electrical system.

Place a Do Not Operate tag at the Start/Stop switch location to inform personnel that the equipment is being worked on.

Water Temperature Fault

The current flow for the circuit that is described in this section is applicable for all engines. The engine must be running at a speed with a coolant temperature that is hot enough to close the water temperature contactor switch (WTS). The water temperature contactor switch is normally open. The following events occur in the electric circuit in order to shut down the engine. The engine will shut down when the temperature of the coolant system is greater than the maximum temperature that is set for the WTS.

1. When the WTS (line 6) closes, the current flows across the terminals (TS-7) (line 6) and (TS-8) (line 14).
2. Current flows through the diode (D1) (line 23). This closes the time delay relay (TD1) across contacts (TD1-6) and (TD1-7) (line 33).
3. When the (SR1) is energized, the switch closes across contacts (SR1-30) and (SR1-87) (line 43).
4. When the (SR1) is energized, the fuel shutoff solenoid (FSOS) (line 43) also becomes energized. This stops the fuel flow to the engine.

NOTICE

To avoid possible engine damage or another immediate shutdown, the water temperature fault must be corrected before attempting to restart the engine.

Even though the starter motor circuit can now be engaged, there is no fuel flow to the engine. The fuel flow to the engine is stopped until the coolant temperature falls below the rating for the water temperature contactor switch (WTS). When the coolant temperature falls below the rating for the water temperature contactor switch (WTS), the contactor switch opens again. The fuel shutoff solenoid is de-energized when the switch reopens. This allows fuel flow to the engine. The engine can then be restarted.

When the coolant temperature decreases below the rating of the water temperature contactor switch, the switch opens again. The time delay relay also causes a delay of 70 seconds before the fuel shutoff solenoid (FSOS) is de-energized. The engine can then be restarted.

WARNING

Accidental engine starting can cause injury or death to personnel working on the equipment.

To avoid accidental engine starting, disconnect the battery cable from the negative (-) battery terminal. Completely tape all metal surfaces of the disconnected battery cable end in order to prevent contact with other metal surfaces which could activate the engine electrical system.

Place a Do Not Operate tag at the Start/Stop switch location to inform personnel that the equipment is being worked on.

2301A Electric Governor Control

The 2301A Electric Governor Control activates all of the components that are in the electric protection system. The components are activated in the same manner when the nonelectric governor is used. One difference exists in the main circuit. The fuel shutoff solenoid (FSOS) (line 34) is not used.

When the electric governor control is used, the engine must run in a normal condition in order for the electric circuit to operate in the manner that is described below.

1. Current flows from the terminals (TS-28) (line 27) and (TS-31) (line 35), which are located on the terminal strip in the junction box.
2. Current from terminals (TS-28) (line 27) and (TS-31) (line 35) flows through the preregulator (PR) (line 38) or the fuse (F4) to the electric governor control.
3. When the engine flywheel is rotating, the current also flows through the electric governor actuator (EGA) (line 52).

When a fault in the system causes the current to energize the slave relay (SR1), the following events occur in the electric circuit in order to stop the engine.

1. The slave relay (SR1) opens across the contacts (SR1-30) and (SR1-87a) (line 45). The relay closes across the contacts (SR1-30) and (SR1-87) (line 43).
2. When the circuit opens across contacts (SR1-30) and (SR1-87a), the current is stopped to the electric governor control.
3. Current to the electric governor actuator (EGA) is also stopped.

4. The mechanical spring load in the electric governor actuator (EGA) will now move the fuel control rod in order to stop fuel flow to the engine.

Note: With the exception of the differences that are described in this section of the manual, all of the fault circuits in the electric protection system are identical for the 2301A Electric Governor Control and for the nonelectric governor control.

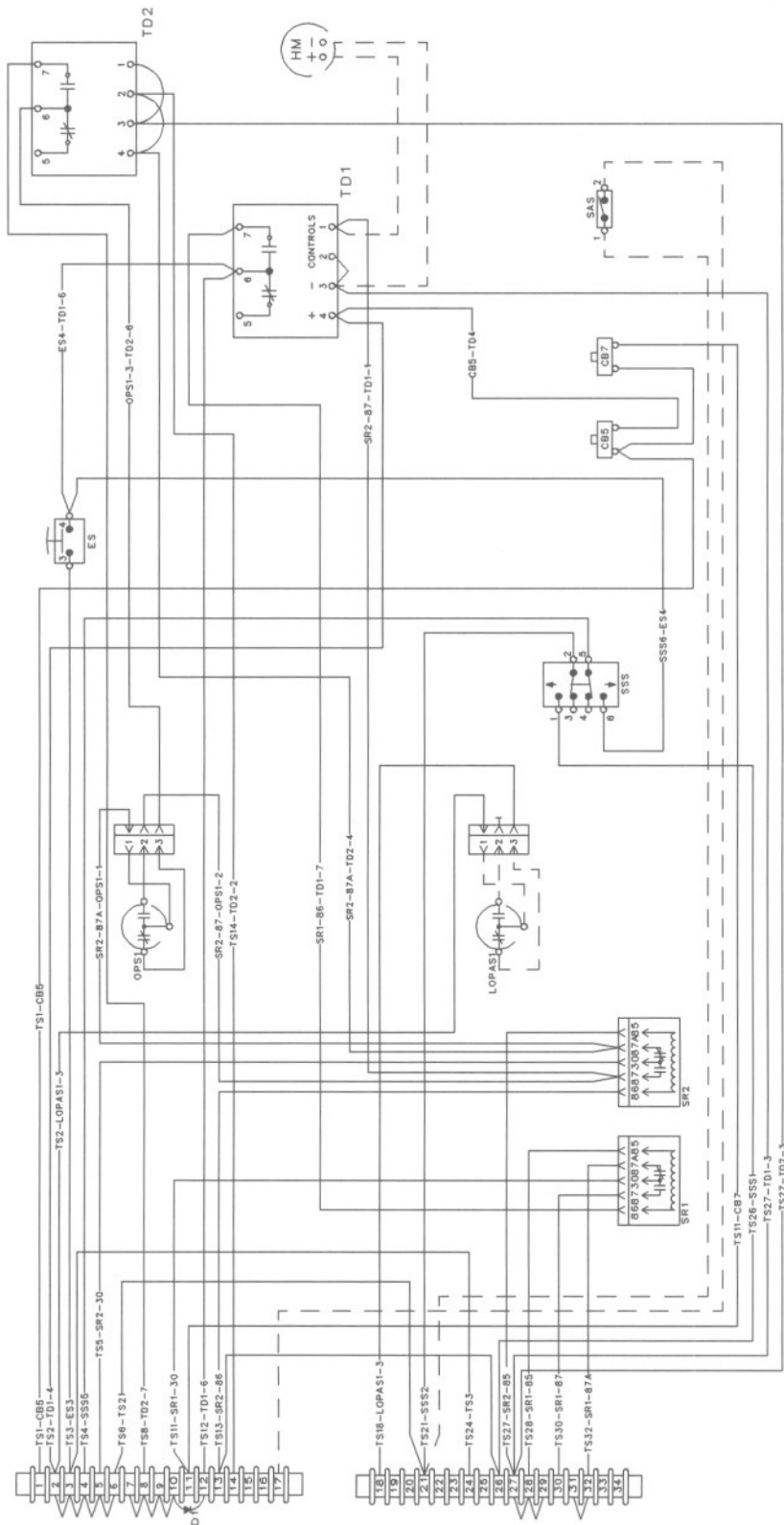

Illustration 53

Junction Box Wiring for ETS with OP and WT that does not require a switchgear for use on 3200 through 3400 Engines

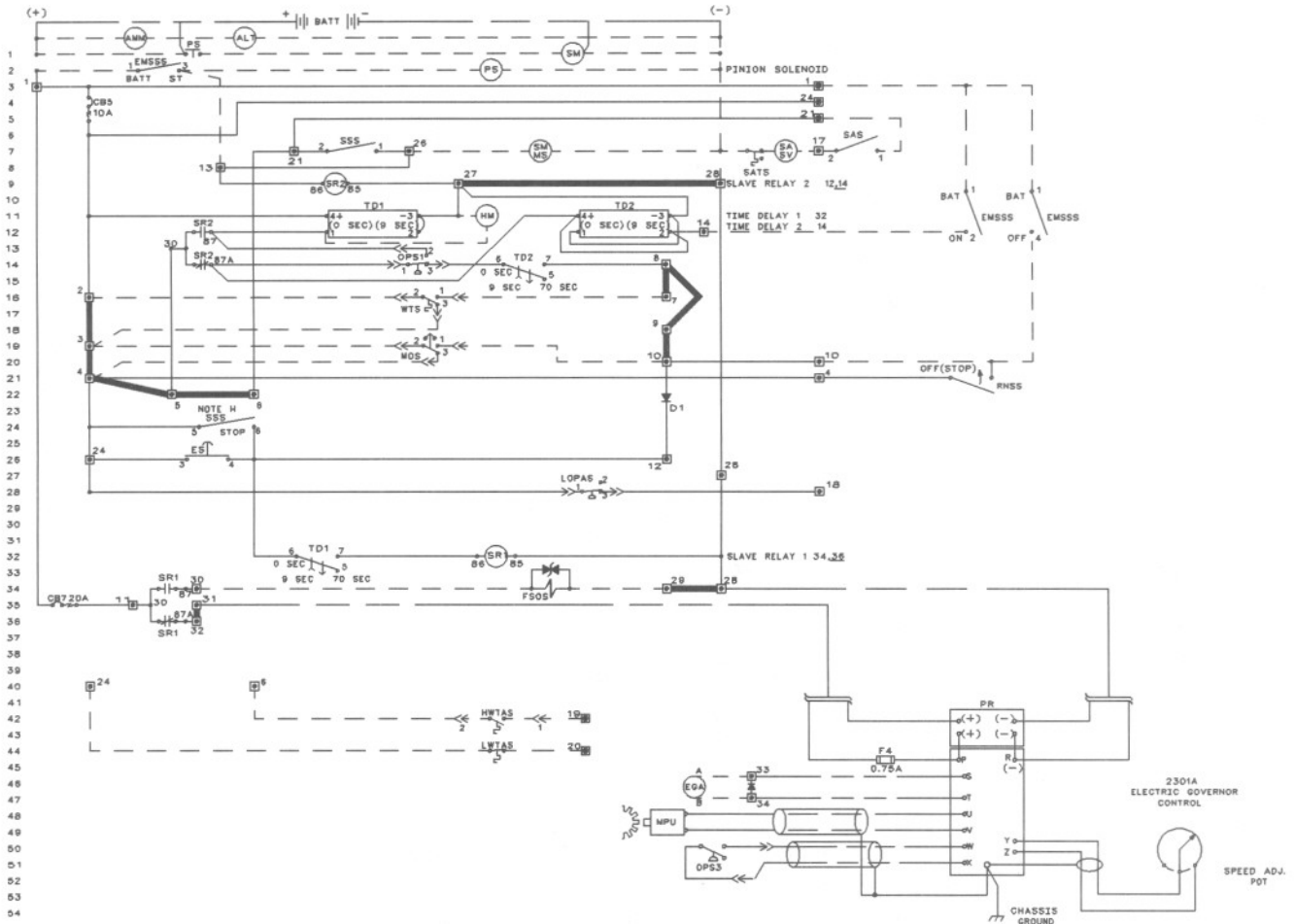
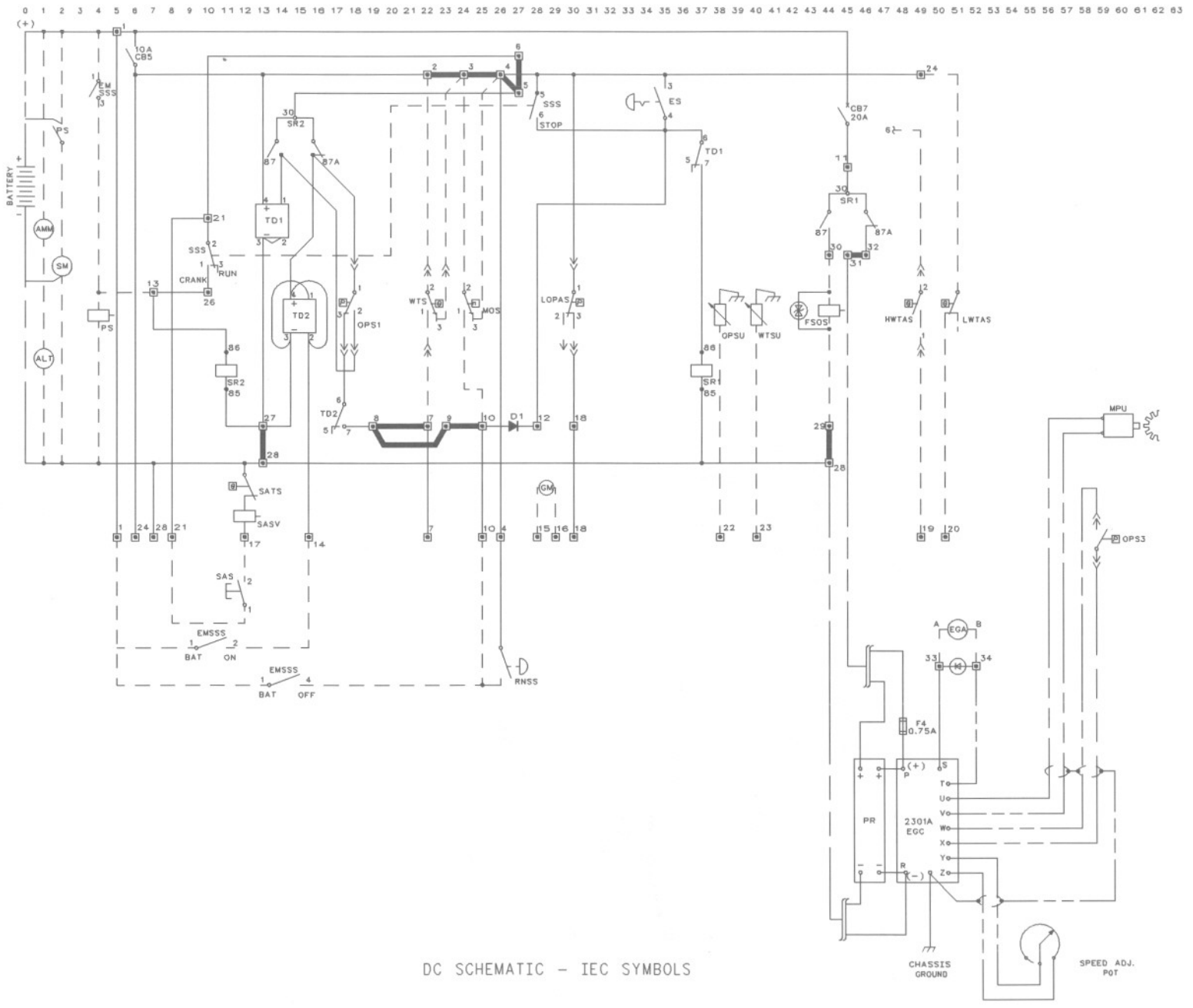

Illustration 54

JIC Schematic for ETS with OP and WT that does not require a switchgear for use on 3200 through 3400 Engines



DC SCHEMATIC - IEC SYMBOLS

Illustration 55
IEC Schematic for ETS with OP and WT that does not require a switchgear for use on 3200 through 3400 Engines

900292542

ITEM	QTY	MEAS UNIT	PART NO.	NAME
PARTS LIST				
1	34		9C-3186	TERMINAL
2	15		5P-1475	TERMINAL
3	10		7T-6364	TERMINAL
4	4		5P-3059	TERMINAL
B 5	70		1S-9593	STRAP
6	2		7N-7780	PIN
7	3		7N-7779	SOCKET
8	1		9G-3695	PLUG
9	2		9C-3662	GROMMET
10	2		7N-7782	HOUSING
11	1	dm	5P-1038	TUBE
12	49	dm	5P-4704	WIRE
13	28	dm	6V-8242	WIRE
14	133	dm	5P-9078	WIRE

TERMINATION	TERM ITEM NO	GA	LENGTH REF	COLOR IDENT	ITEM NO	TERM ITEM NO	TERMINATION
CB5	2	14	203	TAN	12	2	CB7
CB5	2	14	173	TAN	12	2	TD1-4
ES4	1	18	184	TAN	14	1	TD1-6
OPSI-3	7	18	450	TAN	14	1	TD2-6
SR1-85	3	18	932	TAN	14	1	TD1-7
SR2-87A	3	18	450	TAN	14	6	OPSI-1
SR2-87A	3	18	301	TAN	14	1	TD2-4
SR2-87	3	18	510	TAN	14	7	OPSI-2
SR2-87	3	18	1013	TAN	14	1	TD1-1
SS56	11	18	353	TAN	14	1	ES4
TD2-1	1	18	110	G/Y	13	1	TD2-3
TS1	2	14	1097	TAN	12	2	CB5
TS2	2	14	1124	TAN	12	2	TD1-4
TS2	1	18	703	TAN	14	6	LOPASI-1
TS3	1	18	960	TAN	14	1	ES3
TS4	1	18	1051	TAN	14	4	SSS5
TS5	1	18	461	TAN	14	3	SR2-30
TS6	1	18	85	TAN	14	1	TS2-1
TS8	1	18	532	TAN	14	3	TD2-7
TS11	2	14	1311	TAN	12	2	CB7
TS11	2	14	297	TAN	12	3	SR1-30
TS12	1	18	1132	TAN	14	1	TD1-6
TS13	1	18	349	TAN	14	1	SR2-85
TS13	1	18	135	TAN	14	1	TS26
TS14	1	18	750	TAN	14	1	TD2-2
TS18	1	18	682	TAN	14	7	LOPASI-3
TS21	1	18	1062	TAN	14	4	SSS2
TS24	2	14	113	TAN	12	2	TS3
TS26	1	18	1119	TAN	14	4	SSS1
TS27	1	18	384	G/Y	13	3	SR2-86
TS27	1	18	1240	G/Y	13	1	TD1-3
TS28	1	18	290	G/Y	13	3	SR1-86
TS28	1	18	720	G/Y	13	1	TD2-3
TS30	2	14	262	TAN	12	3	SR1-87
TS32	2	14	234	TAN	12	3	SR1-87A

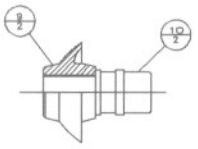
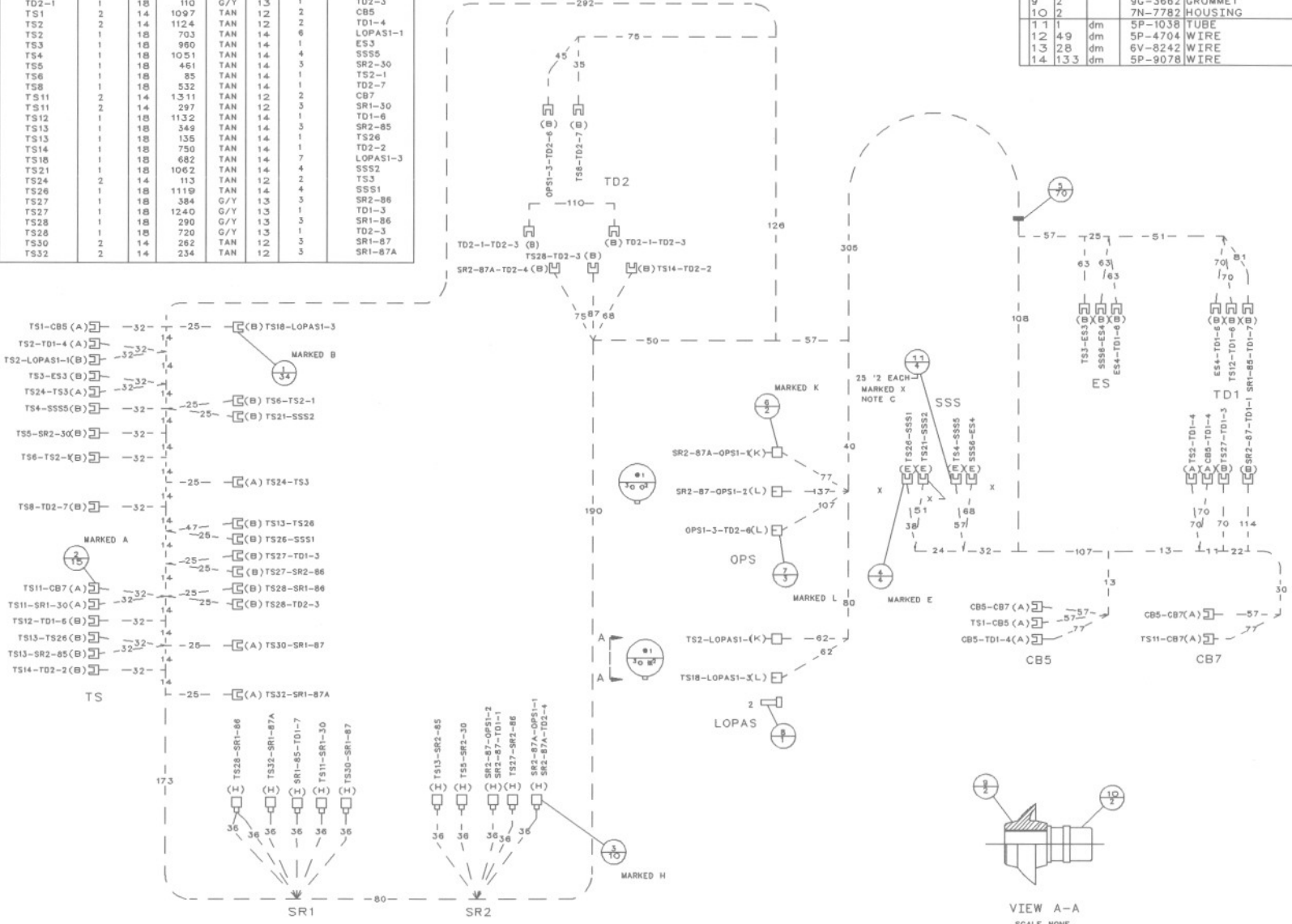

VIEW A-A
SCALE NONE
TYPICAL 2 PLACES

Illustration 56
61 - 1841 Wiring Harness for ETS with OP, WT, and OS that does not require a switchgear for use on 3200 through 3400 Engines
900292543

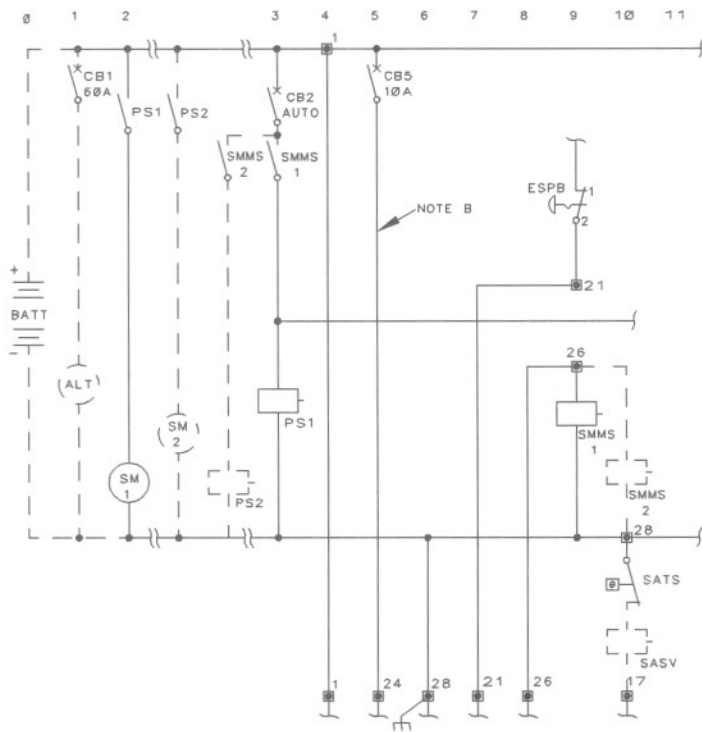

IEC SYMBOLS

NOTE A: FOR COMPLETE SCHEMATIC REFER TO JUNCTION BOX WIRING DIAGRAM

NOTE B: WIRE ONLY PROVIDED ON ENERGIZED TO SHUTOFF (ETS) ENGINES

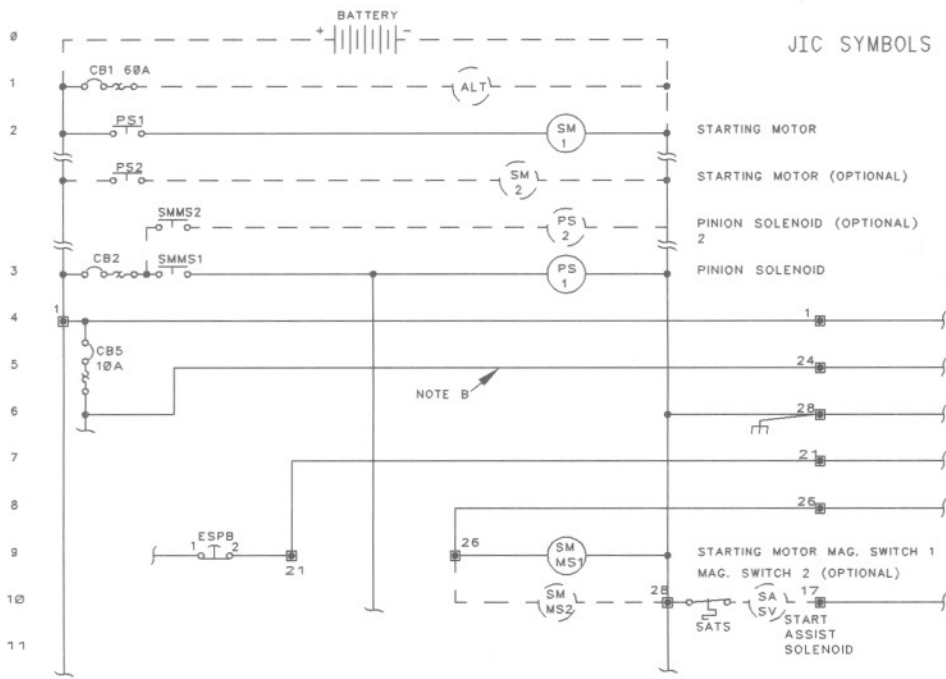

JIC SYMBOLS

Illustration 57
IEC and JIC Schematics of dual starting motors (if equipped)

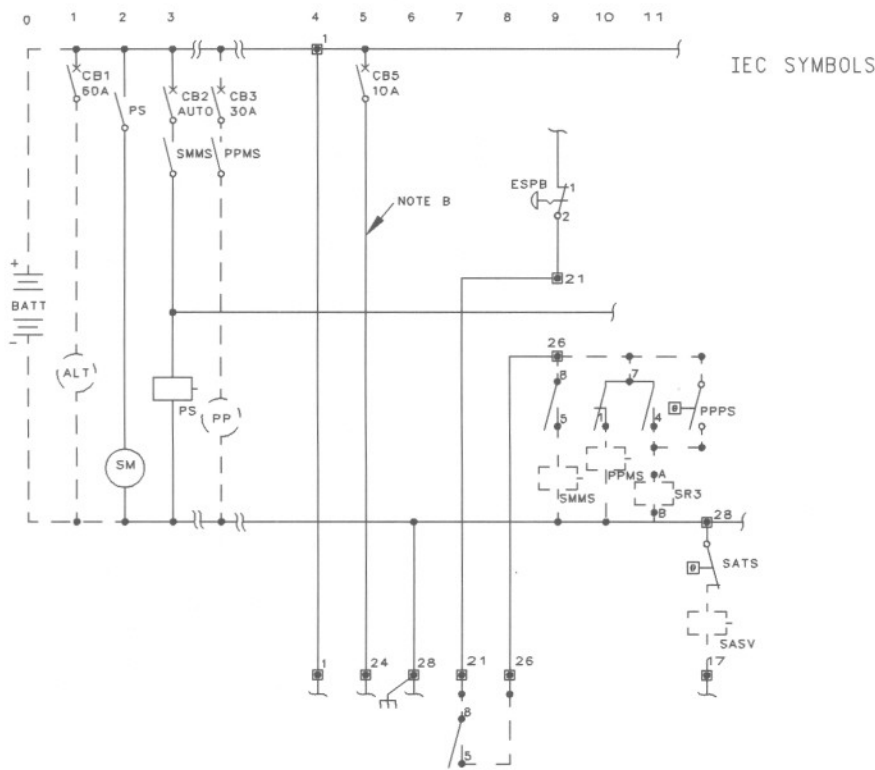

NOTE A: FOR COMPLETE SCHEMATIC REFER TO JUNCTION BOX WIRING DIAGRAM

NOTE B: WIRE ONLY PROVIDED ON ENERGIZED TO SHUTOFF (ETS) ENGINES

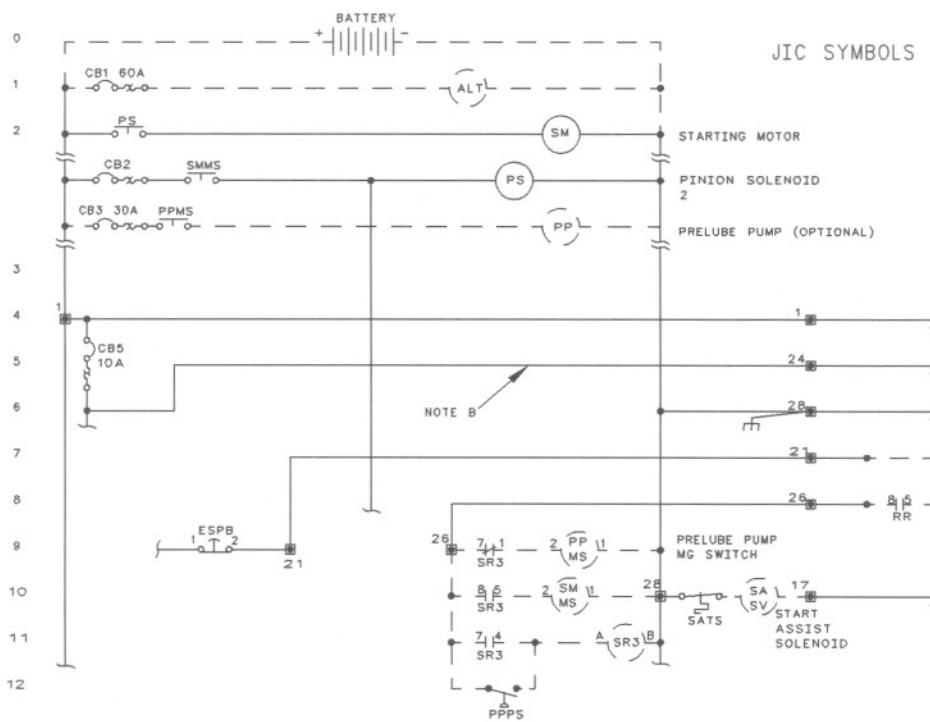

Illustration 58
IEC and JIC Schematics for a prelude pump (if equipped)

i00660713

Abbreviations and Symbols

SMCS Code: 7400

Introduction

"Abbreviations and Symbols" contains the abbreviations, symbols, wiring sizes, wiring color and number codes for the ETR/ETS electric protection system which are placed on drawings and wiring, and referenced in the text of this Service Manual.

The electrical system for the engine contains five subsystems. Each subsystem has different symbols and wire number codes. Abbreviations, symbols, numbering and lettering codes, and wiring requirements are described for the following subsystems.

- Starting
- Charging
- Control
- Monitoring
- Protection

The engine electrical system is designed to improve operational reliability, reduce maintenance problems, improve the flexibility for making changes or additions to the system, and comply with international standards. In order to accomplish these goals, the engine electrical system contains the following components.

- A steel junction box for the control, monitoring, and protection subsystems with standardized mounting locations on each engine series.
- A steel power distribution box for the high amperage starting and charging subsystems with standardized mounting locations on each engine series.
- A wiring harness in a protective nylon conduit that connects the junction box, power distribution box, and the electrical components located on the engine.
- Common heat stamped wire number codes on each wire in the wiring harness for all engine models.
- Common logic for all subsystems on all engine models.

"Description of Electrical System Symbols And Codes" explains how to use and understand the graphical representation of the ETR/ETS electric protection system by component and wiring abbreviations, symbols, and codes.

Description of Electrical System Symbols And Codes

The Point-To-Point graphical system is used in all the wiring diagrams and schematics which help describe the systems operation and troubleshooting of the ETR/ETS electric protection system.

Each wire in the wiring harness is heat stamped the length of the wire with the wire number code as shown in the ETR/ETS Wiring Using Wire Number Codes diagram on Illustration 65. The first number pair of the wiring code identifies the terminal on an engine component to which one end of the wire should be attached. The second number pair of the wiring code identifies the terminal on the component to which the other end of the wire should be attached. The number assigned to each terminal of each component will be the same for all engine models.

The two numbers in the wiring code differentiate between left and right hand mounting. Illustration 60 contains the Number Codes and an example of usage.

The symbols for the engine components will be the same for all 3200-3500 Series Engines.

The use of abbreviations, symbols, and codes is provided by the following example. In order to locate and identify the wire which connects the starting motor magnetic switch and the starting motor, first determine the correct drawing abbreviation. The Abbreviation List on Illustration 59 shows ("SMMS") as the abbreviation symbol for the starting motor magnetic switch. ("SM") is shown as the abbreviation symbol for the starting motor. The symbols for both the starting motor magnetic switch and the starting motor are listed under the Starting System on 61.

Locate the ("SMMS") and ("SM") symbols on the Starting System list on Illustration 61. Because an engine option exists for two starting motors which requires two starting motor magnetic switches, symbols for ("SMMS 1"), ("SMMS 2"), ("SM 1"), and ("SM 2") are shown under the Starting System list. If the engine has only one starting motor, only refer to ("SMMS 1") and ("SM 1").

The Number Code list on Illustration 60 shows that for a component in the starting system a wire number of 050 through 099 is a right hand (RH) usage. A wire number of 150 through 199 is a left hand usage (LH).

The ("SMMS 1") out terminal is designated ("056") (RH) or ("156") (LH). The lower terminal on ("SM 1") is designated ("052") (RH) or ("152") (LH).

On ETR/ETS Wiring Using Wire Number Codes diagram on Illustration 65, the wire connecting ("SMMS 1") and ("SM 1") is coded ("052-056 OR 152-156"). This wire connects the ("SMMS 1") and ("SM 1"). The other wire connected to the same terminal point on ("SMMS 1") is coded ("056-127 OR 127-156"). This code indicates that one end of the wire is connected to the ("SMMS 1") out terminal and the other end of the wire is connected to terminal 27 ("TS-27") on the terminal strip.

WIRE COLOR CODE ABBREVIATIONS

BK	BLACK	T	TAN
BU	LIGHT BLUE	WH	WHITE
CU	COPPER(BARE WIRE)	YL	YELLOW
GN	GREEN	GY	GRAY
GN/YL	GREEN WITH YELLOW STRIPE	PK	PINK
OR	ORANGE	PU	PURPLE
RD	RED		

COMPONENT ABBREVIATIONS

ALT	ALTERNATOR	MOS	MECHANICAL OVERSPEED SWITCH
AMM	AMMETER	MPU	MAGNETIC PICK-UP
AMMS	AMMETER SHUNT	MSG	MURPHY SWICHGAGE®
ASOS	AIR SHUT-OFF SOLENOID	NSS	NORMAL SHUT-OFF SWITCH
ASSV	AIR START SOLENOID VALVE	OPG	OIL PRESSURE GAGE
B-	BATTERY NEGATIVE	OPI	OIL PRESSURE INDICATOR
B+	BATTERY POSITIVE	OPS	OIL PRESSURE SWITCH
BATT	BATTERY	OPSS	OIL PRESSURE STEP SWITCH
BC	BATTERY CHARGER	OPSU	OIL PRESSURE SENDING UNIT
CB	CIRCUIT BREAKER	OSI	OVERSPEED INDICATOR
CFA	CHARGER FAULT ANNUNCIATOR	OSS	OVERSPEED SWITCH
CT	CRANK TERMINATION	OTS	OIL TEMPERATURE SWITCH
D	DIODE	PB	PUSH BUTTON
DVR	DIGITAL VOLTAGE REGULATOR	PDB	POWER DISTRIBUTION BOX
ECLC	EMCP COOLANT LOSS SENSOR CONNECTOR	PEEC	PROGRAMABLE ELECTRONIC ENGINE CONTROL
ECLS	EMCP COOLANT LOSS SENSOR	PP	PRELUBE PUMP
ECM	ENGINE CONTROL MODULE	PPMS	PRELUBE PUMP MAGNETIC SWITCH
ECTS	EMCP COOLANT TEMPERATURE SENSOR	PPPS	PRELUBE PUMP PRESSURE SWITCH
EGA	ELECTRONIC GOVERNOR ACTUATOR	PPR	PRELUBE PUMP RELAY
EGC	ELECTRONIC GOVERNOR CONTROL	RES	RESISTOR
EMCP	ELECTRONIC MODULAR CONTROL PANEL	RESS	REMOTE EMERGENCY SHUT-OFF SWITCH
EMSSS	ENGINE-MOUNTED START-STOP SWITCH	RH	RIGHT HAND
EODC	EMCP OIL & COOLANT SENSOR CONNECTOR	RLS	RAISE, LOWER SWITCH
EOPS	EMCP OIL PRESSURE SENSOR	RNSS	REMOTE NORMAL SHUT-OFF SWITCH
ES	EMERGENCY STOP	RSAS	REMOTE STARTING AID SWITCH
ESS	ELECTRIC SPEED SWITCH	RSC	REMOTE SPEED CONTROL
EXTP	EMCP XDRC TEMP PROBE	RSS	REMOTE START SWITCH
FPS	FUEL PRESSURE SWITCH	S	SENDER
FSOS	FUEL SHUT-OFF SWITCH (ETSO)	SA	STARTING AID
FS	FUEL SOLENOID	SACG	START AID CONTROL GROUP
GSC	GENSET STATUS CONTROL	SAS	STARTING AID SWITCH
GSM	GOVERNOR SYNCH MOTOR	SASV	STARTING AID SOLENIOD VALVE
GSOV	GAS SHUT-OFF VALVE	SATS	STARTING AID TEMPERATURE SWITCH
HRM	HOURLMETER	SBS	STOP-BYPASS SWITCH
HRMOPS	HOURLMETER OIL PRESSURE SWITCH	SM	STARTING MOTOR
HMBSV	HYDRO-MECHANICAL OIL-BYPASS SOLENOID VALVE	SMMS	STARTING MOTOR MAGNETIC SWITCH
HMOPS	HYDRO-MECHANICAL OIL PRESSURE SWITCH	SR	SLAVE RELAY
HMRSSV	HYDRO-MECHANICAL REMOTE SHUT-OFF SOLENOID VALVE	SSS	START STOP SWITCH
HWTA	HIGH WATER TEMPERATURE ALARM	SSMPU	SPEED SWITCH MAGNETIC PICKUP
HWTAS	HIGH WATER TEMPERATURE ALARM SWITCH	TD	TIME DELAY
I	IGNITION	TM	TACHOMETER
LFLA	LOW FUEL LEVEL ALARM	TMMPU	TACHOMETER MAGNETIC PICKUP
LFLAS	LOW FUEL LEVEL ALARM SWITCH	TS	TERMINAL STRIP
LH	LEFT HAND	VM	VOLTMETER
LOLA	LOW OIL LEVEL ALARM	WTG	WATER TEMPERATURE GAGE
LOLAS	LOW OIL LEVEL ALARM SWITCH	WTI	WATER TEMPERATURE INDICATOR
LOPA	LOW OIL PRESSURE ALARM	WTS	WATER TEMPERATURE SWITCH
LOPAS	LOW OIL PRESSURE ALARM SWITCH	WTSU	WATER TEMPERATURE SENDING UNIT
LWLA	LOW WATER LEVEL ALARM	XDRC	TRANSDUCER (EMCP)
LWLAS	LOW WATER LEVEL ALARM SWITCH	Z	ZENER DIODE
LWTA	LOW WATER TEMPERATURE ALARM		
LWTAS	LOW WATER TEMPERATURE ALARM SWITCH		
MGOPG	MARINE GEAR OIL PRESSURE GAGE		
MGOPSU	MARINE GEAR OIL PRESSURE SENDING UNIT		
MGOTA	MARINE GEAR OIL TEMPERATURE ALARM		
MGOTAS	MARINE GEAR OIL TEMPERATURE ALARM SWITCH		

NUMBER CODE

LETTER CODE

STARTING SYSTEM { RH { 000-040 TERMINAL STRIP NO.
041-099 COMPONENT
LH { 100-140 TERMINAL STRIP NO.
141-199 COMPONENT

CHARGING SYSTEM { RH { 200-234 TERMINAL STRIP NO.
235-299 COMPONENT
LH { 300-334 TERMINAL STRIP NO.
335-399 COMPONENT

CONTROL SYSTEM { RH { 400-444 TERMINAL STRIP NO.
445-499 COMPONENT
40A-40J PEEC CONNECTOR
LH { 500-544 TERMINAL STRIP NO.
545-599 COMPONENT
50A-50J PEEC CONNECTOR

MONITORING SYSTEM { RH { 600-634 TERMINAL STRIP NO.
635-699 COMPONENT
LH { 700-734 TERMINAL STRIP NO.
735-799 COMPONENT

PROTECTION SYSTEM { RH { 800-834 TERMINAL STRIP NO.
835-899 COMPONENT
LH { 900-934 TERMINAL STRIP NO.
935-999 COMPONENT

	RH MTD JCT BOX	LH MTD JCT BOX
3114	-	S
3116	-	T
3208	-	B
3304	C	-
3306	D	-
3406	E	E
3408	-	F
3412	-	H
3508	J	-
3512	K	-
3516	L	-
G3406	G	-
G3408	-	M
G3412	-	N
G3512	P	-
G3516	R	-
G3306	X	-
G3304	V	-

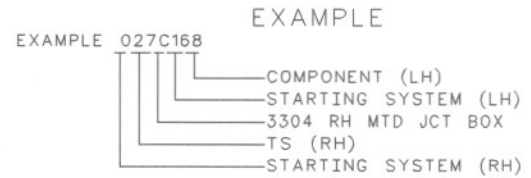

CABLE SIZE		BATTERY CABLE SIZE (MAX ONE-WAY LENGTH) (25~)	
mm ²	GAGE	SINGLE STARTING MOTOR	2 OR 3 STARTING MOTORS
120	0000	5m	2.5m
95	000	4m	2m
70	00	3.25m	1.5m
50	0	2.5m	1.25m

GROUND WIRE SIZE

CHARGING SYSTEM AMPERAGE OUTPUT	WIRE SIZE
0 - 18 AMPS	14 GAUGE
19 - 30 AMPS	10 GAUGE
31 - 45 AMPS	8 GAUGE
46 - 65 AMPS	6 GAUGE
66 - 85 AMPS	4 GAUGE

WOODWARD 2301A ELECTRIC GOVERNOR CONTROL TERMINAL IDENTIFICATION:

SYMBOL	FUNCTION	2301A	2301A
		SPEED CONTROL	LOAD-SHARE
P	BATT+	2	16
R	BATT-	1	15
S	EGA+	6	20
T	EGA-	5	21
U	MAG PICK-UP	7	28
V	MAG PICK-UP	8	29
W	OIL PRESSURE SPEED LIMITER	9	19
X	OIL PRESSURE SPEED LIMITER	10	16
Y	SPEED ADJUSTMENT POT	11	24
Z	SPEED ADJUSTMENT POT	12	23

A FUSE (F4) OR OPTIONAL PRE-REGULATOR (PR) WILL BE PROVIDED WITH THE 2301A SPEED CONTROL ELECTRONIC GOVERNOR OPTION.

STARTING SYSTEM

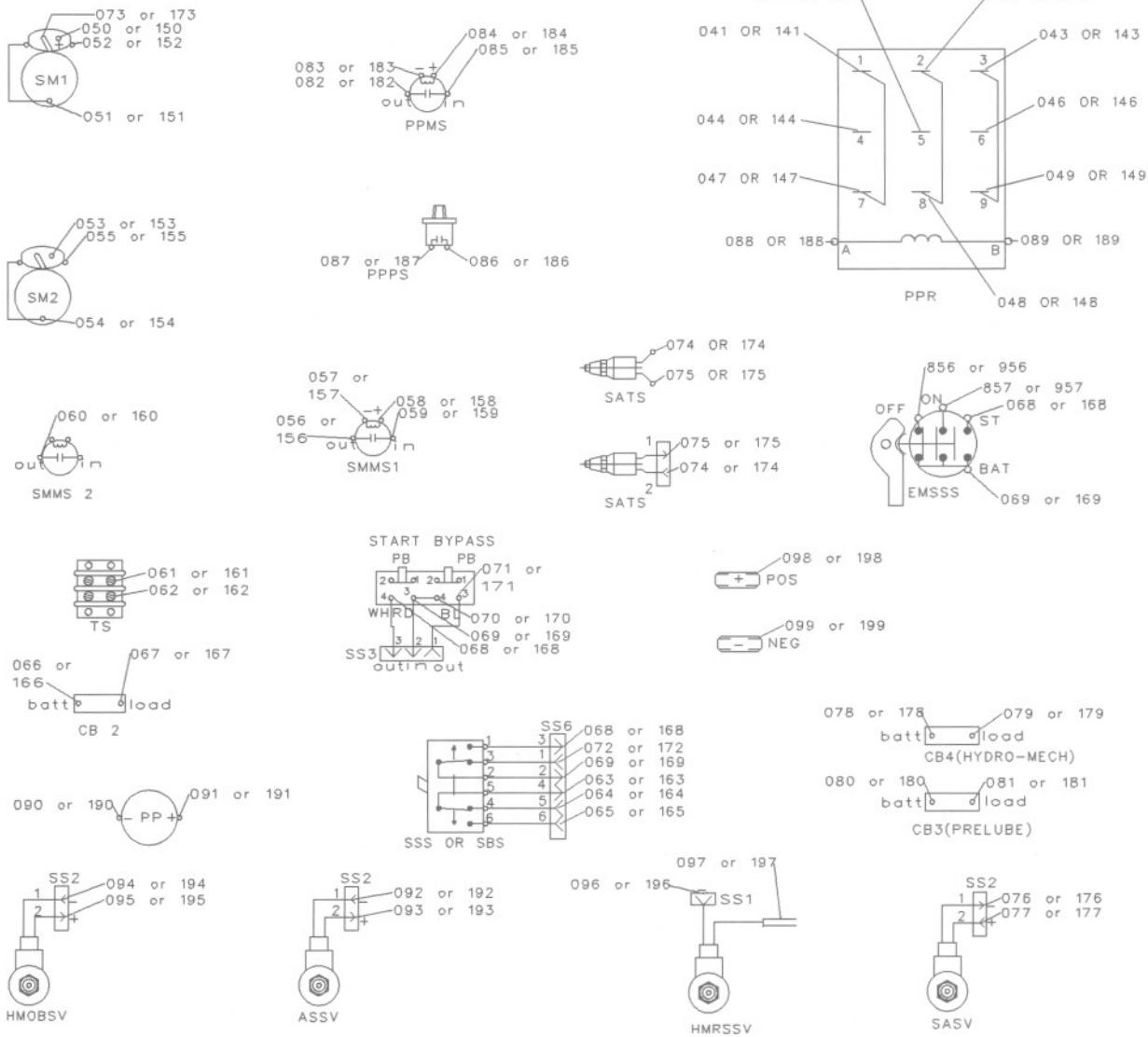

CHARGING SYSTEM

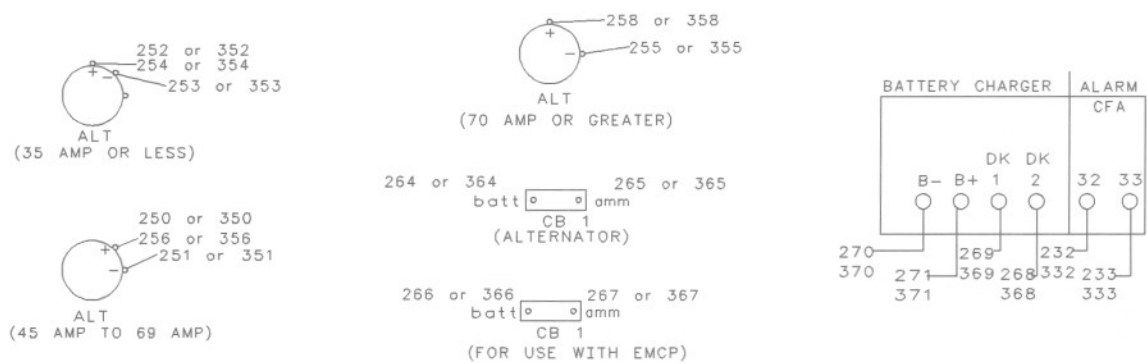
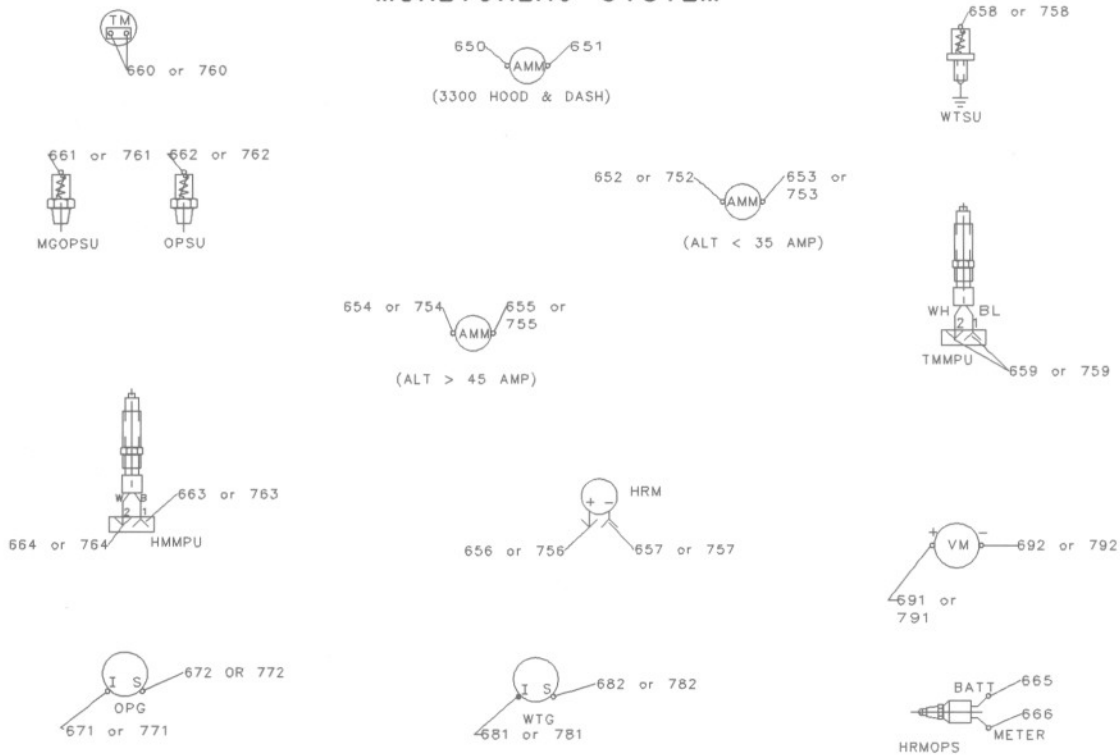
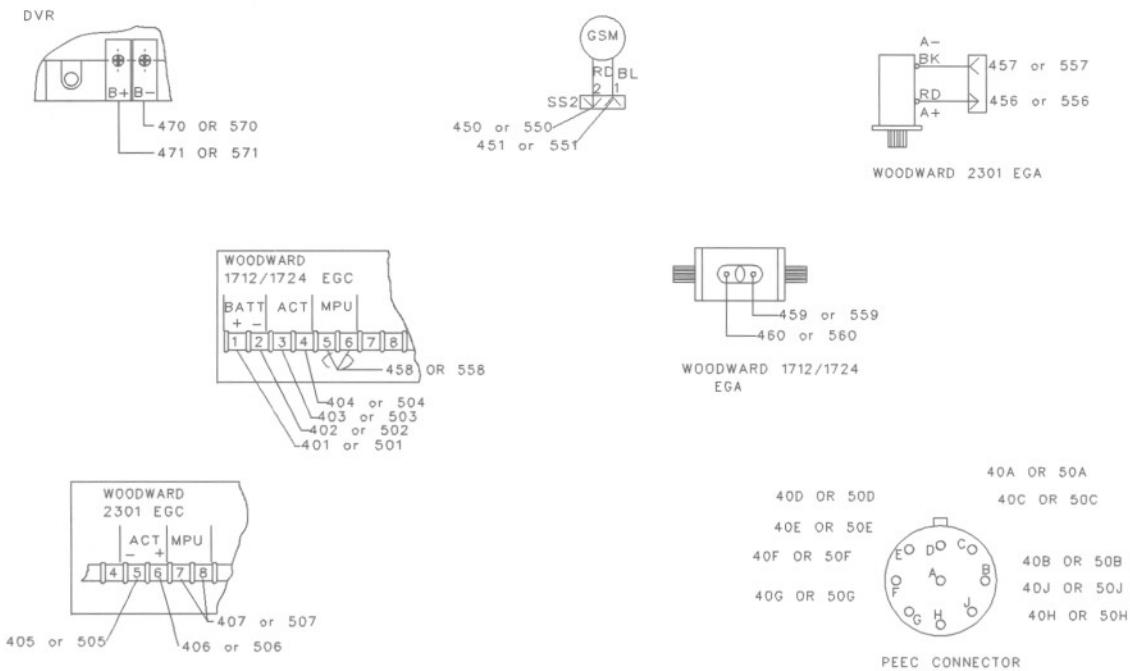

Illustration 61
ETR/ETS Starting And Charging Systems Symbols

MONITORING SYSTEM



CONTROL SYSTEM



PROTECTION SYSTEM

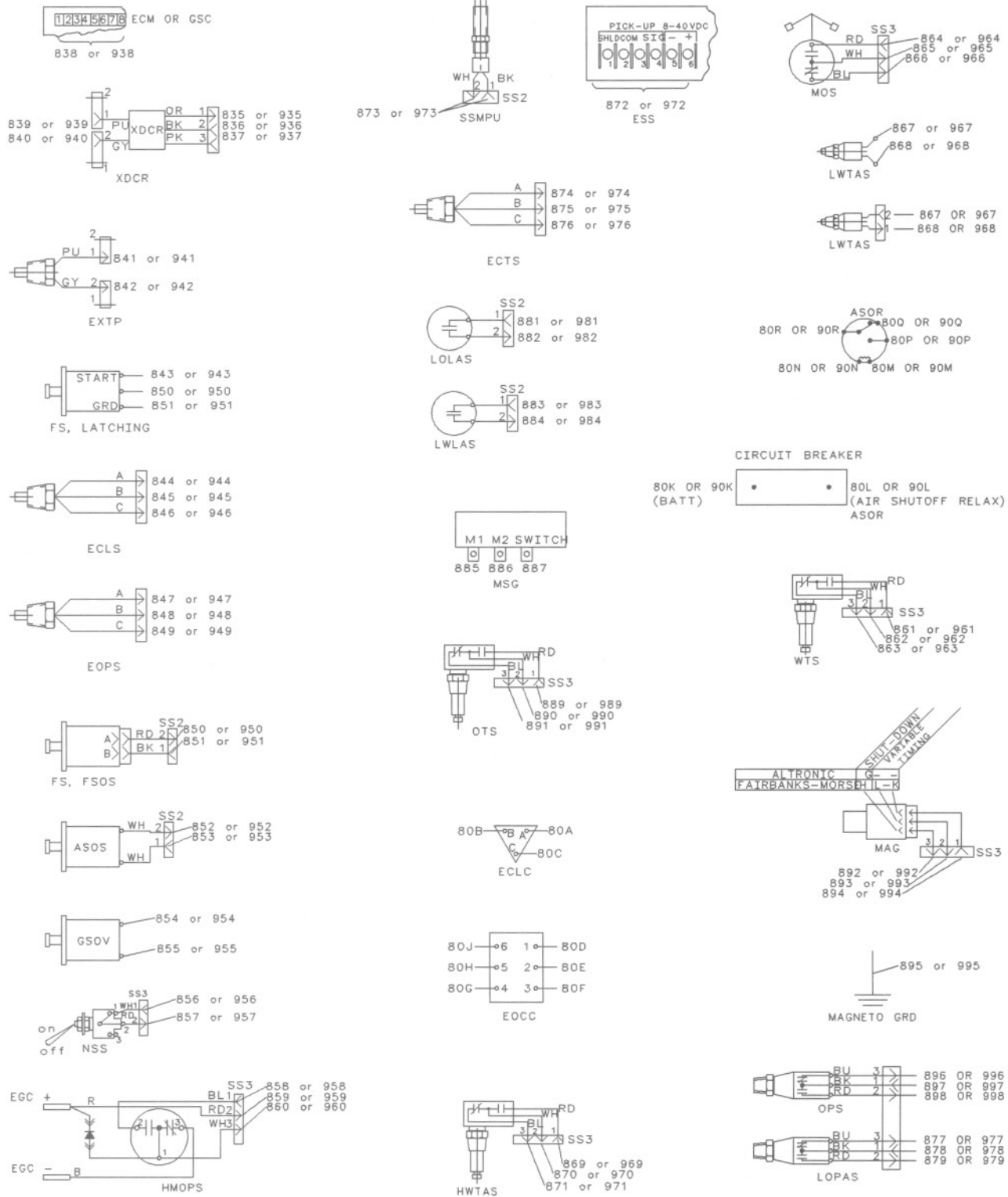

Illustration 63
ETR/ETS Protection System Symbols

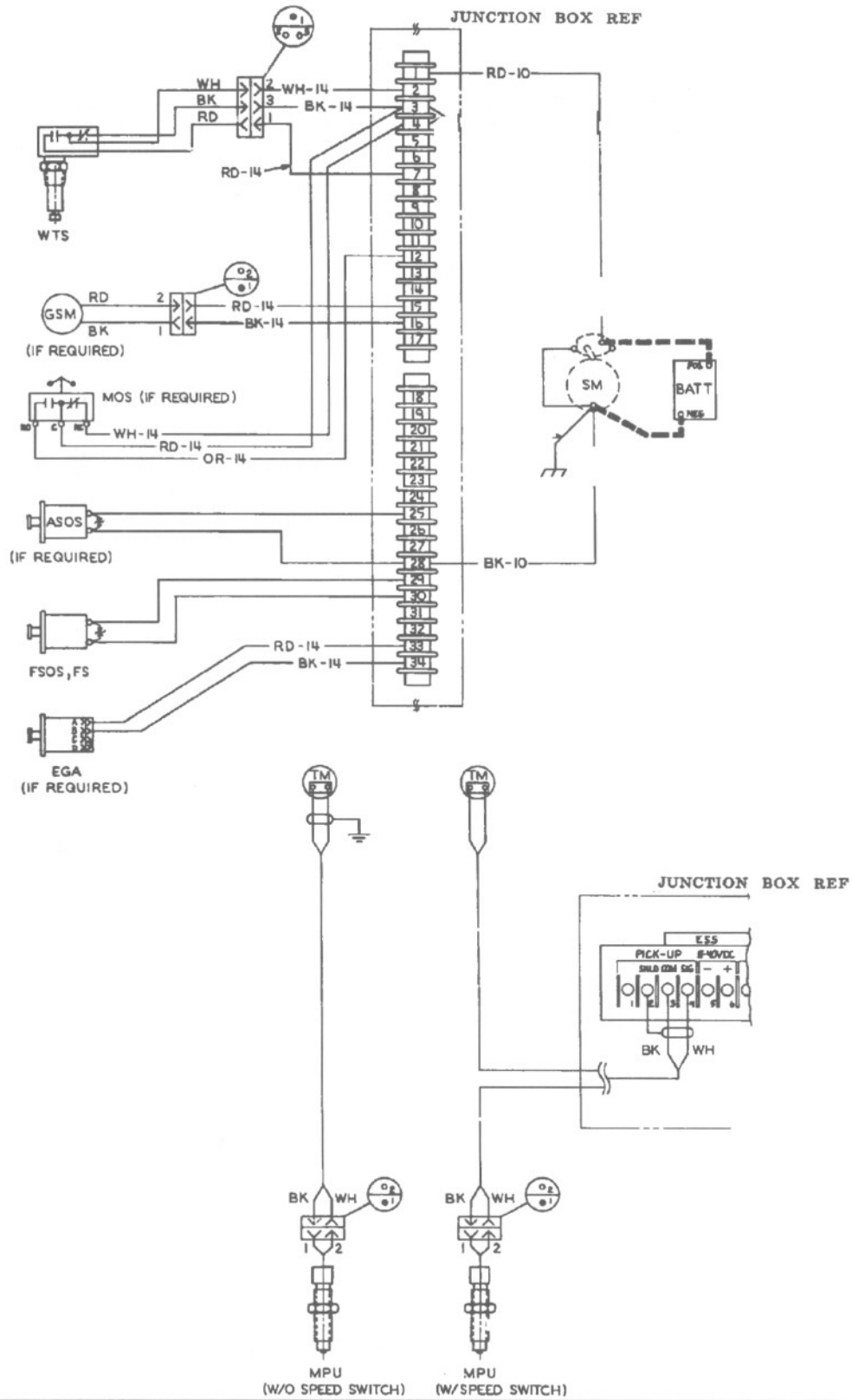

Illustration 64
ETR/ETS Color Coded Wiring Diagram (Typical Example)

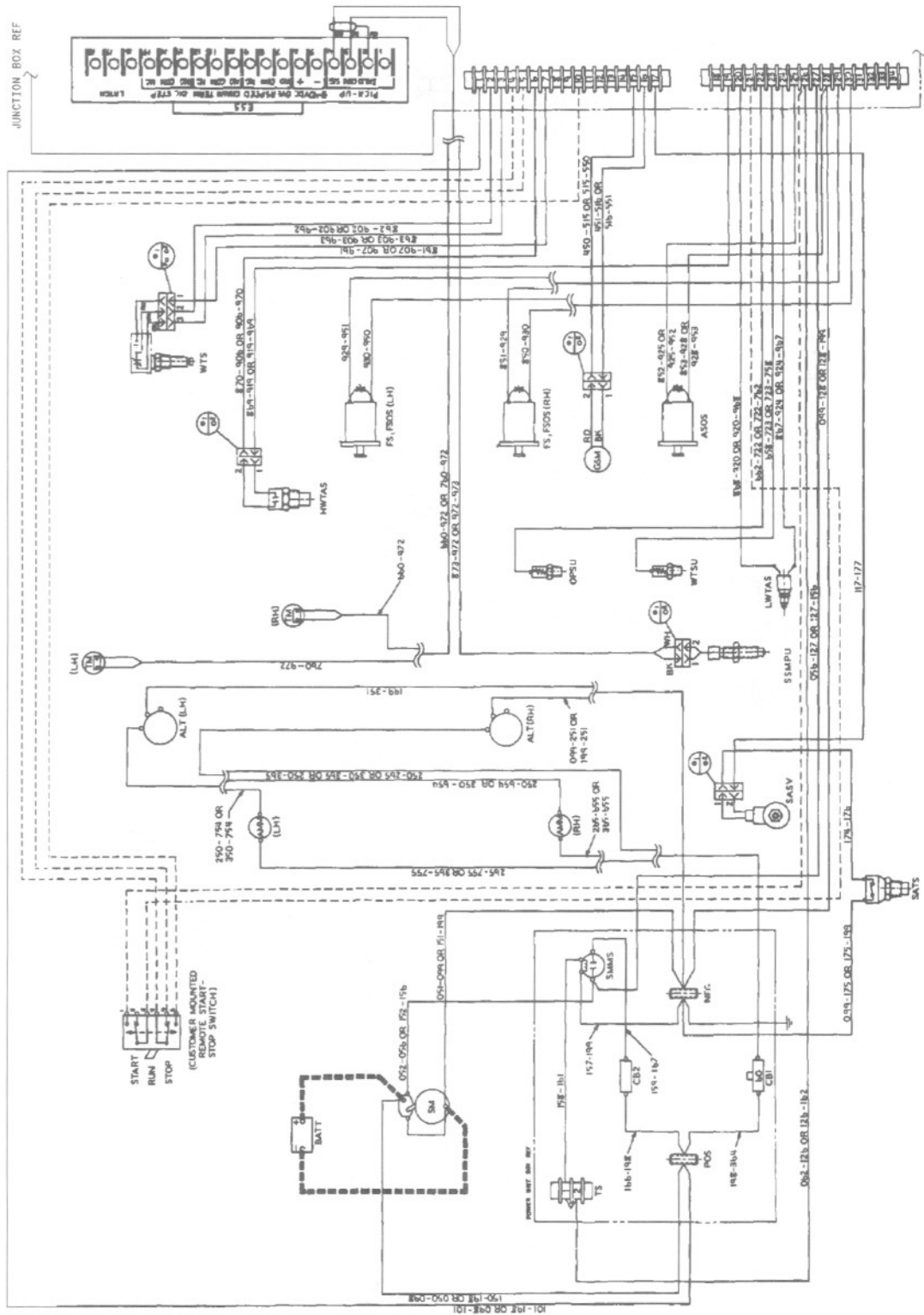

Illustration 65
ETR/ETS Wiring Using Wire Number Codes

Testing and Adjusting Section

i01076334

Troubleshooting

General Troubleshooting Information

i01076177

SMCS Code: 7400-081

Introduction

This troubleshooting manual can aid the technician in locating the causes of existing problems with the engine. Several of the common problems are covered in the troubleshooting procedures. The problems are in no significant order.

First identify the type of protection system that is installed on the engine. The two systems are the Full Protection System and the Partial Protection System. Use the appropriate index to locate the problem with the engine. When you begin the procedure for the problem, start with Step 1 and follow the exact procedure. The steps provide a definite sequence that should be followed in order to eliminate the variables in a logical sequence. The steps are arranged in order. The most common problems that are easiest to check are listed first. The less common problems that are more difficult to check are listed last.

When the cause of the problem is found, correct the problem and stop the test. Do not continue through the complete procedure after the problem has been solved.

Note: Before you perform the test procedures, ensure that the emergency stop (ES), the electronic speed switch (ESS), and all of the circuit breakers have been reset. The circuit breakers are on the front of the junction box and in the electrical system.

Electric Protection System Functional Test

SMCS Code: 7400-035

Test each component of the electrical protection system in order to determine that all of the components work properly. Use the tables below to determine if the components are working properly. The tests should be performed on an engine that is started for the first time and at recommended service intervals. The service intervals are provided in the Operation and Maintenance Manual.

If a problem occurs, refer to the index for the correct troubleshooting procedures. In order to determine the correct engine rpm, refer to the speed specification chart in the Testing and Adjusting section.

Test 1 - Overspeed Switch (OS)

Table 6

Overspeed Switch (OS)			
Step	Engine RPM	Action	Correct Result
A	25 + 5 rpm less than 75% Overspeed Verify rpm	Press the 75% Verify button	No engine shutdown
B	25 + 5 rpm more than 75% Overspeed Verify rpm	Press the 75% Verify button	Air and fuel shutoff
C	Manually reset the air shutoff lever at the top of the air inlet, if equipped. Press the ESS reset button.		

Test 2 - Emergency Stop Switch (ES)

Table 7

Emergency Stop Switch (ES)			
Step	Engine RPM	Action	Correct Result
A	Any rpm above the crank terminate rpm	Press the push button for the emergency stop switch	Air and fuel shutoff
B	Manually reset the air shutoff lever at the top of the air inlet, if equipped. Turn ES switch in the direction that is shown on the face of the push button in order to reset the switch.		

Test 3 - Normal Stop Switch (NSS)

Table 8

Normal Stop Switch (NSS)			
Step	Engine RPM	Action	Correct Result
A	Any rpm above the crank terminate rpm	Push the normal stop switch (NSS)	Fuel shutoff

Test 4 - Water Temperature Contactor Switch

Table 9

Water Temperature Contactor Switch (WTS)			
Step	Engine RPM	Action	Correct Result
A	Any rpm above the crank terminate rpm	Place a jumper across terminals TS-2 and TS-7.	Fuel shutoff
B	Remove the jumper from terminals TS-2 and TS-7.		

Test 5 - Oil Pressure Switch (OPS1)

Table 10

Oil Pressure Switch (OPS1)			
Step	Engine RPM	Action	Correct Result
A	Any rpm above the crank terminate rpm	Place a jumper across terminals OPS1-1 and OPS1-3.	Fuel shutoff
B	Remove the jumper from terminals OPS1-1 and OPS1-3.		

Test 6 - Oil Pressure Switch (OPS2)

Table 11

Oil Pressure Switch (OPS2)			
Step	Engine RPM	Action	Correct Result
A	25 + 5 rpm less than the setting for the oil step speed	Place a jumper across terminals OPS2-1 and OPS2-3.	No engine shutdown.
B	25 + 5 rpm more than the setting for the oil step speed	Place a jumper across terminals OPS2-1 and OPS2-3.	Fuel shutoff 9 seconds after the oil step speed is reached.
C	Remove the jumper from across terminals OPS2-1 and OPS2-3.		

i01072732

Troubleshooting the ETS Full Protection System (OP, WT, OS)

SMCS Code: 7400-035

Problem 1

The engine cranks but the engine does not start.

1. Check the engine fuel system.
 - a. Crank the engine.
 - b. Observe the action of the fuel rack, the governor, and the position of the air shutoff valve, if equipped.
 - c. If a 2301A Electric Governor is installed, measure the voltage that is supplied to the governor.

Result

- The fuel rack and the governor move in the FUEL ON direction. If equipped, the air shutoff lever is in the RUN position.

The problem is in the engine or in the fuel system. Refer to the engine Service Manual. STOP.

- The fuel rack does not move. The governor does not move in the FUEL ON direction.

The start/stop switch was not in the START position. Go to Step 2.

- The air shutoff valve is in the shutoff position. If equipped, the air shutoff solenoid is in the shutoff position. One or both of the conditions may be possible.

Manually reset the air shutoff lever. Go to Step 5 if the lever or the solenoid cannot be reset or if the solenoid trips on each attempt to start the engine.

- A 2301A Electric Governor is installed and the supply voltage is greater than 15 volts.

The problem is in the governor or the actuator system. Refer to the 2301A Electric Governor Service Manual, SENR3585. STOP.

- A 2301A Electric Governor is installed and the supply voltage is less than 15 volts.

The problem is in the wiring to the 2301A Electric Governor. Go to Step 3.

2. Check the slave relay (SR1) and the fuel rack.
- Disconnect the wire from terminal (TS-30) to the fuel shutoff solenoid (FSOS). The wire is on the terminal strip in the junction box.

- Crank the engine. Stop the engine with the emergency stop switch if trouble occurs.

Result

- The engine starts and the engine runs.

The slave relay (SR1) is energizing the shutoff solenoid. Go to Step 3.

- The engine does not start.

The shutoff solenoid is stuck or the fuel rack is stuck in the shutoff position. Find the source of the problem and correct the source of the problem. Reconnect the wire from the terminal (TS-30) to the fuel shutoff solenoid. STOP.

3. Check the slave relay (SR1).

- Disconnect the wire that connects terminal (SR-85) of the slave relay (SR1) to terminal (TD-7) of the time delay relay. Insulate the end of the removed wire in order to prevent contact with any conductive surfaces.
- Crank the engine. Stop the engine with the emergency stop switch, if trouble occurs.

Result

- The engine starts and the engine runs.

The (SR1) is not faulty. Go to Step 4.

- The engine does not start.

Contacts (SR-30) and (SR-87) of (SR1) that are normally open have been shorted and the fuel shutoff solenoid is energized. If a 2301A Electric Governor is installed, contacts (SR-30) and (SR-87a) of (SR1) that are normally closed are open or the wiring to the 2301A Electric Governor is faulty. Replace the (SR1) or repair the wiring problem. Refer to Testing and Adjusting, "Slave Relay Test". Reconnect the wire at the terminal of the time delay relay (TD-7). STOP.

4. Check the protection components.

- Disconnect the jumper between the terminals (TS-9) and (TS-10) on the terminal strip in the junction box.

- Ensure that the emergency stop switch (ES) has been reset and that the start/stop switch is in the RUN position.

- Crank the engine. Stop the engine with the emergency stop switch, if trouble occurs.

Result

- The engine starts and the engine runs.

The problem is in the switches for the oil pressure or in the water temperature contactor switch. Go to Step 7.

- The engine does not start.

The problem is not in the protection components. Check the time delay relay (TD). Refer to Testing and Adjusting, "Time Delay Relay Verification Test". Also, check the start/stop switch. The start/stop switch could have an open circuit to the terminal (TS-10) on the terminal strip of the junction box. Check the wiring in the junction box in order to find the cause of the open circuit.

5. Check the overspeed setting of the electronic speed switch and the diode (D2).

- Ensure that the push button for the emergency stop (ES) has been reset.

- Check the indicator lamp for the electronic speed switch (ESS). Press the reset button if the lamp is turned on.

- Crank the engine. Stop the engine with the emergency stop switch, if trouble occurs.

Result

- The engine starts and the engine runs after the ES or the ESS has been reset.

The problem has been solved. STOP.

- The engine starts and the engine runs without resetting the ES or the ESS.

The problem is intermittent. Check the mechanical condition of the latch mechanism in the air shutoff control, if equipped. STOP.

- If equipped, the air shutoff valve closes before the engine is cranked.

Go to Step 6.

- If equipped, the air shutoff valve closes and the engine overspeed lamp turns on while the engine is cranked or shortly after the engine has been started.

The engine is exceeding the overspeed setting of the ESS. Recalibrate the ESS. Refer to Testing and Adjusting, "Overspeed Calibration".

- If equipped, the air shutoff valve closes and the engine overspeed lamp does not turn on while the engine is cranked or shortly after the engine is started.

The ES may have a short or the system wiring is incorrect. Check the ES and the wiring. Also check that the contacts for the engine overspeed on the ESS are not shorted. Repair the faulty components or replace the faulty components. STOP.

6. Check the slave relay (SR2).

- Disconnect the wire at terminal (TS-25) on the terminal strip in the junction box. The wire runs from terminal (SR2-87) of the slave relay (SR2), if equipped.
- Crank the engine.

Result

- The engine starts and the engine runs.

The problem is in the slave relay (SR2) or the wiring to the (SR2). Refer to Testing and Adjusting, "Diode Test".

- If equipped, the air shutoff valve closes while the engine is cranking or immediately after the engine is started.

A mechanical problem exists in the latch mechanism of the air shutoff control. Repair the problem. STOP.

7. Check the protection switches.

- Ensure that the wire that was disconnected from terminal (TS-25) in Step 6 is now connected.
- Disconnect the two wires at terminal (ESS-7) of the ESS. Keep the ends of the wires insulated from each other.
- Crank the engine. Stop the engine with the emergency stop switch, if trouble occurs.

Result

- The engine starts and the engine runs.

The problem is not the (SR2), if equipped. Check the wiring to (ESS-7). Repair the wiring or replace the wiring.

- The engine will not start.

Check the (SR2), if equipped. There may be a shorted contact. Refer to Testing and Adjusting, "Slave Relay Test". Replace a faulty (SR2). If the (SR2) is not faulty check the wiring at the (SR2). Repair the wiring or replace the wiring.

8. Check the protection switches.

- Reconnect the jumper that was removed from the terminals (TS-9) and (TS-10) on the terminal strip in the junction box during Step 4.
- Test the water temperature contactor switch (WTS), the oil pressure switch (OPS1), and the oil pressure switch (OPS2), if equipped. Disconnect one switch at a time from the connection in the junction box.
- Start the engine. If the engine starts, reconnect the switch and disconnect one of the remaining switches until the problem is identified.

Result

- The engine starts and the engine runs when the WTS, the OPS1, or the OPS2 is disconnected.

One of the switches may be faulty. Refer to Testing and Adjusting, "Engine Oil Pressure Switch Test" and Testing and Adjusting, "Water Temperature Contactor Switch Test". Replace the faulty switch.

- The protection switch is replaced and the engine starts.

The problem has been solved. STOP.

- The protection switch is replaced but the engine does not start.

Check the switch that was replaced. Check the engine and the junction box wiring. Check the time delay relay (TD). Refer to Testing and Adjusting, "Time Delay Relay Verification Test". Repair the wiring and replace the components that are faulty. STOP.

- The engine does not start when the WTS, OPS1, or the OPS2 is disconnected.

Terminal (TS-9) on the terminal strip of the junction box is being energized because of the wiring. Locate the wiring problem and correct the wiring problem. STOP.

Problem 2

The engine does not crank.

1. Check the start/stop switch.
 - a. Ensure that the emergency stop switch (ES) has been reset.
 - b. Connect a switch with a 2 amp capacity between terminals (TS-21) and (TS-26) of the junction box.
 - c. Close the switch momentarily, but do not start the engine.
 - d. Disconnect the switch after the test is completed.

Results

- The engine cranks.

The start/stop switch is faulty or the wiring to the switch is faulty. Replace the switch or repair the wiring.

- The engine does not crank.

Go to Step 2.

2. Check the electronic speed switch.
 - a. Connect a switch with a 2 amp capacity between terminals (TS-26) and (TS-24) of the junction box.
 - b. Close the switch momentarily but do not start the engine.
 - c. Disconnect the switch after the test is completed.

Result

- The engine cranks.

The electronic speed switch (ESS) or the emergency stop switch (ES) is faulty. Go to Step 3.

- The engine does not crank.

Reset the circuit breaker (CB5) and repeat Step 2. If the engine does not crank go to Step 4.

3. Check the emergency stop switch and the electronic speed switch.
 - a. Connect a switch with a 2 amp capacity between terminals (ESS-12) and (TS-26) of the junction box.
 - b. Close the switch momentarily, but do not start the engine.
 - c. Disconnect the switch after the test is completed.

Result

- The engine cranks.

The ES or the wiring to the ES is faulty. Replace the ES or repair the wiring. STOP.

- The engine does not crank.

The ESS or the wiring to the ESS is faulty. Go to Step 5.

4. Check the components of the starting system.
 - a. Check the voltage at terminal (TS-24) of the junction box.

Result

- The voltage is low. Low voltage is between 1 volt and 20 volts.

Charge the battery or repair the loose connections between the battery cable terminal and the battery. STOP.

- The voltage is above 20 volts.

The magnetic switch (MS), the pinion solenoid (PS), or the starting motor (SM) is faulty. The circuit breaker (CB2) may need to be reset. Reset the circuit breaker and repair the component that is faulty.

- The voltage is zero (less than 1 volt).

The circuit breaker (CB5) is being overloaded or the circuit breaker is faulty. Repair the short circuit or replace the circuit breaker. STOP.

5. Check the electronic speed switch.

- a. Connect a switch with a 2 amp capacity between terminals (ESS-11) and (TS-26) of the junction box.
- b. Close the switch momentarily, but do not start the engine.

Result

- The engine cranks.

The ESS is faulty. Repair the ESS or replace the ESS. STOP.

- The engine does not crank.

The wiring to the ESS is faulty. Repair the wiring to the ESS. STOP.

Problem 3**The engine starts and shutdown occurs immediately, or engine cranking terminates.**

1. Check the switches on the protection system.
 - a. Wait for 70 seconds after the engine has shutdown before you attempt to restart the engine. If an electric starting motor or a DC-actuated starting motor is equipped with the engine, immediate restarting of the engine can be enabled.

Enable the immediate restart of an electric starting motor by removing the jumper that is between terminals (TS-27) and (TS-28). Connect terminal (TS-27) to the output side of the starting motor magnetic switch (SMMS).

Enable the immediate restart of a DC-actuated starting motor by removing the jumper that is between terminals (TS-27) and (TS-28) of the junction box. Install the jumper between terminals (TS-26) and (TS-27) of the junction box.
 - b. Ensure that the engine lubrication system is filled to the correct level with oil.
 - c. Ensure that the oil pressure increases when the engine is cranking.
 - d. Remove the jumper that is between terminals (TS-9) and (TS-10) of the junction box.
 - e. Crank the engine. Stop the engine with the emergency stop switch, if trouble occurs.

Result

- The engine starts and the engine runs.

One of the oil pressure switches or the water temperature contactor switch is causing the problem. Go to Step 8 of "Problem 1".

- The engine cranking terminates or shutdown of the engine occurs immediately after starting.

Go to Step 2.

2. Check the start/stop switch and the slave relay (SR1).
 - a. Remove the jumper that is between terminals (TS-9) and (TS-10) of the junction box.
 - b. Crank the engine. Stop the engine with the emergency stop switch, if trouble occurs.
 - c. Measure the voltage at terminal (TS-10).
 - d. Observe the air shutoff valve, if equipped. Check if the air shutoff valve moves into the shutoff position.

Result

- The air shutoff valve moves to the shutoff position.

Go to Step 5 of "Problem 1".

- A voltage appears on terminal (TS-10) when the engine stops. The air shutoff valve does not move to the shutoff position.

The start/stop switch is in the STOP position. If the start/stop switch is not in the STOP position, check for a faulty switch or incorrect wiring that is inside of the junction box. Replace the faulty component. STOP.

- A voltage does not appear at terminal (TS-10) when engine shutdown occurs.

Go to Step 1 of "Problem 1".

Problem 4**The starting motor remains engaged or the starting motor continues to run after the engine is running.**

1. Check the components of the starting circuit.

- a. Measure the voltages at terminal (TS-26) of the junction box and at terminal (ESS-12) of the electronic speed switch while the engine is running.

Result

- The voltage at both terminals is zero volts.

The problem is in the starting motor (SM), the pinion solenoid (PS), or the magnetic switch (MS). Repair the faulty component. STOP.

- The voltage at terminal (ESS-12) is between 15 volts and 32 volts. The voltage at terminal (TS-26) is above 15 volts or below 15 volts but not zero volts.

The contacts for the crank terminate (CT) switch of the electronic speed switch (ESS) do not open. Refer to Testing and Adjusting, "Crank Terminate Speed Calibration". If the ESS is not faulty, check diode (D3). Refer to Testing and Adjusting, "Diode Test".

- The voltage at both terminals is between 15 volts and 32 volts.

The voltage at the terminals is greater than zero volts. During the normal operation of the start/stop switch, the start/stop switch opens across the contacts of the START position. Also, the start/stop switch closes across the contacts of the RUN position. The switch closes when the toggle or the lever of the switch moves from the START position to the RUN position. Repair the switch if the voltage is zero.

- The voltage at terminal (ESS-12) is not zero.

The CT contacts of the ESS are not opening. Refer to Testing and Adjusting, "Crank Terminate Speed Calibration".

Problem 5

The engine shutdown occurs after the engine runs for more than 3 minutes.

1. Check the overspeed setting on the electronic speed switch (ESS).
 - a. Observe the indicator lamp on the ESS.
 - b. Reset the air shutoff lever, if equipped.
 - c. Crank the engine. Stop the engine with the emergency stop switch, if trouble occurs.

Result

- The indicator lamp on the ESS is turned on.

Overspeed is indicated as the cause of the engine shutdown. Press the "RESET" button of the ESS. Find the cause of the overspeed. Refer to Testing and Adjusting, "Overspeed Verification Test" and Testing and Adjusting, "Overspeed Calibration". If the overspeed is adjusted properly and the problem persists, check the shielded cable. Only the shield should be connected to terminal 2 on the ESS. STOP.

- The indicator lamp is turned off.

Go to Step 2.

2. Check the protection switches.
 - a. Remove the jumper that is between terminals (TS-9) and (TS-10) of the junction box.
 - b. Crank the engine. Stop the engine with the emergency stop switch, if trouble occurs.

Result

- The engine starts and the engine runs.

The problem is in the oil pressure switches or the water temperature contactor switch. Go to Step 8 of "Problem 1".

- The engine starts but engine shutdown occurs immediately.

Go to Step 1 of "Problem 3".

- The engine starts and the engine runs but engine shutdown occurs after the engine runs for more than 3 minutes.

Go to Step 3.

- The engine cranks but the engine does not start.

Go to Step 1 of "Problem 1".

3. Check the start/stop switch.
 - a. Disconnect the wire in the junction box that connects terminal (SR1-85) of the slave relay (SR1) to terminal (TD-7) of the time delay relay (TD).
 - b. Disconnect the wire from terminal (TD-7) and insulate the exposed wire.

- c. Crank the engine. Stop the engine with the emergency stop switch, if trouble occurs.

Result

- The engine starts and the engine runs.

The start/stop switch has a short circuit or a wiring problem is causing a voltage at terminal (TD-7). Reconnect the wire to the terminal.

4. Check the start/stop switch.

- a. Disconnect the wire that runs from the STOP position of terminal (SSS-6) to terminal (TD-6). Terminal (SSS-6) is on the start/stop switch.
- b. Disconnect the wire at terminal (TD-7).
- c. Crank the engine. Stop the engine with the emergency stop switch, if trouble occurs.

Result

- The engine starts and the engine runs.

The start/stop switch is faulty. Replace the switch. STOP.

- Engine shutdown still occurs.

Reconnect the wire to terminal (TD-7). Go to Step 5

5. Check the slave relay (SR1).

- a. Disconnect the wire that connects terminal (TS-10) of the junction box to terminal (TD-6) of the time delay relay.
- b. Disconnect the wire at terminal (TD-6).
- c. Crank the engine. Stop the engine with the emergency stop switch, if trouble occurs.

Result

- The engine starts and the engine runs.

The start/stop switch is faulty. Replace the start/stop switch. STOP.

- Engine shutdown still occurs.

The contacts of SR1 periodically close. The problem may also be with the governor or the fuel supply to the engine. Refer to the Engine Service Manual. If a 2301A Electric Governor is used, the SR1 contacts may be opening. Refer to 2301A Electric Governor Service Manual, SENR3585. Test SR1. Refer to Testing and Adjusting, "Slave Relay Test".

Problem 6

Engine shutdown does not occur when a fault is detected.

1. Check the protection switches and the crank terminate switch of the electronic speed switch.
 - a. Reset circuit breakers (CB7) and (CB6).
 - b. Start the engine and run the engine at low idle.
 - c. Place the jumper across the correct terminals in order to isolate the protection switch for testing. Test only one switch at a time. Remove the jumper and test the next switch. Use the following order to test the switches.
 - d. Place a jumper between terminals (TS-6) and (TS-8) of the junction box in order to test the oil pressure switch (OPS1). Conduct the test and remove the jumper.
 - e. Place a jumper between terminals (ESS-13) and (TS-8) of the junction box. Terminal (ESS-13) is on the electronic speed switch (ESS). This is done in order to test the oil pressure switch (OPS2), if equipped. Conduct the test and remove the jumper.
 - f. Test the oil step function of the ESS. Run the engine at high idle for the test. Conduct the test and remove the jumper between terminals (ESS-13) and (TS-8). This is only done on 3500 Engines.
 - g. Place a jumper between terminals (TS-2) and (TS-7) of the junction box in order to test the water temperature contactor switch (WTS).
 - h. Refer to Testing and Adjusting, "Overspeed Verification Test" in order to test the overspeed switch of the ESS.

Result

- When (OPS1) or the WTS is tested at low engine idle, engine shutdown occurs.

The (OPS1) or the WTS is faulty. Refer to Testing and Adjusting, "Engine Oil Pressure Switch Test" and Testing and Adjusting, "Water Temperature Contactor Switch Test". Replace a faulty switch. STOP.

- When (OPS2) is tested at low engine idle, the engine continues to run. When the engine overspeeds, engine shutdown occurs.

Refer to Testing and Adjusting, "Engine Oil Pressure Switch Test" to test OPS2. Replace a faulty switch. If no problems can be identified, the circuit breaker (CB7) may have tripped. Check the wiring for a short circuit to the ground. STOP.

- When OPS1 is tested at low engine idle, the engine does not stop. When the WTS is tested, engine shutdown occurs.

The crank terminate switch of the ESS or the wiring to the ESS is faulty. Refer to Testing and Adjusting, "Crank Terminate Speed Calibration". Diode (D4) may have failed. Refer to Testing and Adjusting, "Diode Test". Replace the faulty component. STOP.

- When the WTS is tested, engine shutdown does not occur.

The jumper that is between terminals (TS-9) and (TS-10) of the junction box has not been connected. Connect the jumper. If the jumper was installed correctly, test diode (D3). Refer to Testing and Adjusting, "Diode Test". Replace the diode (D3), if necessary. If the diode is not faulty, go to Step 2.

- When the OPS2 is tested with the engine at high idle, engine shutdown does not occur.

The oil pressure step switch of the ESS, or the wiring to the ESS is faulty. Refer to Testing and Adjusting, "Oil Step Speed Calibration". Ensure that the ESS has the oil pressure step function. If terminals (ESS-13), (ESS-14), and (ESS-15) have wires that are connected, the oil pressure step function is installed.

- The Overspeed Verification Test does not cause engine shutdown by energizing the fuel shutoff solenoid (FSOS). When the WTS is tested, engine shutdown occurs.

The overspeed switch (OS) of the ESS may not be closing, or the wiring to the ESS may be faulty. Refer to Testing and Adjusting, "Overspeed Calibration". The diode (D2) may also be faulty. Refer to Testing and Adjusting, "Diode Test". Replace the diode, if necessary. STOP.

- The Overspeed Verification Test does not activate the air shutoff solenoid (ASOS), if equipped.

The slave relay (SR2), the ASOS, or the air shutoff mechanism is faulty. Refer to Testing and Adjusting, "Slave Relay Test". Repair the faulty components. STOP.

2. Check the slave relay (SR2).

- If a fuel shutoff solenoid (FSOS) is installed, measure the voltage at terminal (TS-30) of the junction box. If a 2301A Electric Governor is installed, measure the voltage at terminal (TS-31) of the junction box.
- Crank the engine. Stop the engine with the emergency stop switch, if trouble occurs.
- While the engine is running, use a jumper on the WTS and measure the voltages. Refer to Step 1 for the correct procedure.

Result

- The voltage on terminal (TS-30) is between 15 volts and 32 volts when the WTS is tested.

The slave relay (SR1) is not faulty. The fuel shutoff solenoid (FSOS) is faulty or the linkage for the fuel shutoff is jammed. Repair the faulty components. STOP.

- The voltage on terminal (TS-30) is zero or less than 15 volts when the WTS is tested.

The slave relay (SR1) is faulty or the circuit breaker (CB7) is open. Repair the faulty components. STOP.

i01075748

Troubleshooting the ETS Partial Protection System (OP, WT) (3200-3400 Engines)

SMCS Code: 7400-035

Problem 1

The engine cranks but the engine does not start.

1. Check the engine fuel system.
 - a. Crank the engine.
 - b. Observe the action of the fuel rack and the governor.
 - c. If a 2301A Electric Governor is installed, measure the voltage that is supplied to the governor.

Result

- The fuel rack and the governor move into the FUEL ON direction.

The problem is in the engine or in the fuel system. Refer to the engine Service Manual. STOP.

- The fuel rack does not move. The governor does not move in the FUEL ON direction.

The start/stop switch was not in the START position. Go to Step 2.

- A 2301A Electric Governor is installed and the supply voltage is greater than 15 volts.

The problem is in the governor or the actuator system. Refer to the 2301A Electric Governor Service Manual, SENR3585. STOP.

- A 2301A Electric Governor is installed and the supply voltage is less than 15 volts.

The problem is in the wiring to the 2301A Electric Governor. Go to Step 3.

2. Check the slave relay (SR1) and the fuel rack.
 - a. Disconnect the wire from terminal (TS-30) to the fuel shutoff solenoid (FSOS). The wire is on the terminal strip in the junction box.

- b. Crank the engine. Stop the engine with the emergency stop switch if trouble occurs.
- c. Reconnect the wire when the test is completed.

Result

- The engine starts and the engine runs.

The slave relay (SR1) is energizing the shutoff solenoid. Go to Step 3.

- The engine does not start.

The shutoff solenoid is stuck or the fuel rack is stuck in the shutoff position. Find the source of the problem and correct the source of the problem. STOP.

3. Check the slave relay (SR1).
 - a. Disconnect the wire that connects terminal (SR1-85) of the slave relay (SR1) to terminal (TD-7) of the time delay relay. Insulate the end of the removed wire in order to prevent contact with any conductive surfaces.
 - b. Crank the engine. Stop the engine with the emergency stop switch, if trouble occurs.
 - c. Reconnect the wire when the test is completed.

Result

- The engine starts and the engine runs.

The (SR1) is not faulty. Go to Step 4.

- The engine does not start.

Contacts (SR1-30) and (SR1-87) of (SR1) that are normally open have been shorted and the fuel shutoff solenoid is energized. If a 2301A Electric Governor is installed, contacts (SR-30) and (SR-87a) of (SR1) that are normally closed are open or the wiring to the 2301A Electric Governor is faulty. Replace the (SR1) or repair the wiring problem. Refer to Testing and Adjusting, "Slave Relay Test". STOP.

4. Check the protection switches and the time delay relay (TD).
 - a. Disconnect the jumper between the terminals (TS-9) and (TS-10) of the junction box.

- b. If the engine is equipped with a low oil pressure indicator, disconnect the diode that is between terminals (TS-8) and (TS-10). The cathode lead of the diode should be connected to terminal (TS-10).
- c. Ensure that a jumper is not installed between terminals (TS-8) and (TS-9).
- d. Crank the engine.

Result

- The engine starts and the engine runs.

The problem is in the switches for the oil pressure (OPS1) or in the water temperature contactor switch (WTS). Go to Step 5.

- The engine does not start.

The problem is not in the protection components. Check the time delay relay (TD). Refer to Testing and Adjusting, "Time Delay Relay Verification Test". Also, check the start/stop switch. The start/stop switch could have an open circuit to the terminal (TS-12) of the junction box. Check the wiring in the junction box in order to find the cause of the open circuit.

5. Check the protection switches.

- a. Reconnect the jumper that was removed from the terminals (TS-9) and (TS-10) on the terminal strip in the junction box during Step 4.
- b. Test the water temperature contactor switch (WTS) and the oil pressure switch (OPS1). Disconnect one switch at a time from the connection in the junction box.
- c. Start the engine. If the engine starts, reconnect the switch and disconnect one of the remaining switches until the problem is identified.

Result

- The engine starts and the engine runs when the WTS or OPS1 is disconnected.

One of the switches may be faulty. Refer to Testing and Adjusting, "Engine Oil Pressure Switch Test" and Testing and Adjusting, "Water Temperature Contactor Switch Test". Replace the faulty switch.

- The protection switch is replaced and the engine starts.

The problem has been solved. STOP.

- The protection switch is replaced but the engine does not start.

Check the switch that was replaced. Check the engine and the junction box wiring. Check the time delay relay (TD). Refer to Testing and Adjusting, "Time Delay Relay Verification Test". Repair the wiring and replace the components that are faulty. STOP.

- The engine does not start when the WTS or OPS1 is disconnected.

Terminal (TS-9) on the terminal strip of the junction box is being energized because of the wiring. Locate the wiring problem and correct the wiring problem. STOP.

Problem 2

The engine does not crank.

1. Check the start/stop switch.
 - a. Ensure that the emergency stop switch (ES) has been reset.
 - b. Connect a switch with a 2 amp capacity between terminals (TS-21) and (TS-26) of the junction box.
 - c. Close the switch momentarily, but do not start the engine.
 - d. Disconnect the switch after the test is completed.

Results

- The engine cranks.

The start/stop switch is faulty or the wiring to the switch is faulty. Replace the switch or repair the wiring.

- The engine does not crank.

Go to Step 2.

2. Check the start/stop switch and the emergency stop switch (ES).
 - a. Connect a switch with a 2 amp capacity between terminals (TS-21) and (TS-26) of the junction box.
 - b. Connect a jumper between terminals (TS-21) and (TS-24) of the junction box.

- c. Close the switch momentarily but do not start the engine.
- d. Disconnect the switch after the test is completed.

Result

- The engine cranks.

The start/stop switch or the emergency stop switch (ES) is faulty. Go to Step 3.

- The engine does not crank.

Reset the circuit breaker (CB5) and repeat Step 2. If the engine does not crank go to Step 4.

3. Check the start/stop switch and the emergency stop switch.
 - a. Connect a switch with a 2 amp capacity between terminals (TS-21) and (TS-26) of the junction box.
 - b. Connect a jumper between terminal (TS-4) of the junction box and terminal of the start/stop switch (SSS-4) that is shared.
 - c. Close the switch momentarily, but do not start the engine.
 - d. Disconnect the switch after the test is completed.

Result

- The engine cranks.

The start/stop switch is faulty or the wiring to the switch is faulty. Repair the faulty switch or repair the wiring. STOP.

- The engine does not crank.

The emergency stop switch (ES) or the wiring to the ES is faulty. Repair the wiring. STOP.

4. Check the components of the starting system.
 - a. Check the voltage at terminal (TS-24) of the junction box.

Result

- The voltage is low. Low voltage is between 1 volt and 20 volts.

Charge the battery or repair the loose connections between the battery cable terminal and the battery. STOP.

- The voltage is above 20 volts.

The magnetic switch (MS), the pinion solenoid (PS), or the starting motor (SM) is faulty. The circuit breaker (CB2) may need to be reset. Reset the circuit breaker and repair the component that is faulty.

- The voltage is zero (less than 1 volt).

The circuit breaker (CB5) is being overloaded or the circuit breaker is faulty. Repair the short circuit or replace the circuit breaker. STOP.

Problem 3

The engine starts and shutdown occurs immediately, or engine cranking terminates.

1. Check the switches on the protection system.

- a. Wait for 70 seconds after the engine has shutdown before you attempt to restart the engine. If an electric starting motor or a DC-actuated air starting motor is equipped with the engine, immediate restarting of the engine can be enabled.

Enable the immediate restart of an electric starting motor by removing the jumper that is between terminals (TS-27) and (TS-28). Connect terminal (TS-27) to the output of the starting motor magnetic switch (SMMS).

Enable the immediate restart of a DC-actuated air starting motor by removing the jumper that is between terminals (TS-27) and (TS-28) of the junction box. Install the jumper between terminals (TS-26) and (TS-27) of the junction box.

- b. Ensure that the engine lubrication system is filled to the correct level with oil.
- c. Ensure that the oil pressure increases when the engine is cranking.
- d. Remove the jumper that is between terminals (TS-9) and (TS-10) of the junction box.
- e. Start the engine.

Result

- The engine starts and the engine runs.

The oil pressure switch or the water temperature contactor switch is causing the problem. Go to Step 5 of "Problem 1".

- Engine cranking terminates or engine shutdown occurs immediately after starting.

Go to Step 2.

2. Check the start/stop switch and the emergency stop switch (ES).
 - a. Remove the jumper that is between terminals (TS-9) and (TS-10) of the junction box.
 - b. Start the engine.
 - c. Measure the voltage at terminal (TS-12).

Result

- A voltage appears on terminal (TS-12) when the engine stops. The air shutoff valve does not move to the shutoff position.

The start/stop switch or the ES is in the STOP position. If the start/stop switch or the ES is not in the STOP position, check for a faulty switch or incorrect wiring that is inside of the junction box. Replace the faulty component. STOP.

- A voltage does not appear at terminal (TS-12) when engine shutdown occurs.

Go to Step 1 of "Problem 1".

Problem 4

The starting motor remains engaged or the starting motor continues to run after the engine is running.

1. Check the components of the starting circuit.
 - a. Measure the voltages at terminal (TS-26) of the junction box while the engine is running.

Result

- The voltage at the terminal is zero volts.

The problem is in the starting motor (SM), the pinion solenoid (PS), or the magnetic switch (MS). Repair the faulty component. STOP.

- The voltage at the terminal is between 15 volts and 32 volts.

The START terminals of the start/stop switch are normally closed. This is normal for an automatic start system. In a manual start system, the switches should be normally open. The switch is on terminals (SSS-1) and (SSS-2) for a normal start/stop switch. Repair the faulty switch. STOP.

Problem 5

The engine shutdown occurs after the engine runs for more than 3 minutes.

1. Check the protection switches.
 - a. Remove the jumper that is between terminals (TS-9) and (TS-10) of the junction box.
 - b. If the engine is equipped with a low oil pressure indicator, disconnect the diode that is between terminals (TS-8) and (TS-10). The cathode lead of the diode should be connected to terminal (TS-10).
 - c. If the engine is equipped with a low oil pressure indicator, ensure that a jumper is not installed between terminals (TS-8) and (TS-9).
 - d. Start the engine.
 - e. Reconnect the jumper that is between terminals (TS-9) and (TS-10) of the junction box after the test is completed.

Result

- The engine starts and the engine runs.

The problem is in the oil pressure switch or the water temperature contactor switch. Go to Step 5 of "Problem 1".

- The engine starts but engine shutdown occurs immediately.

Go to Step 1 of "Problem 3".

- The engine starts and the engine runs but engine shutdown occurs after the engine runs for more than 3 minutes.

Go to Step 2.

- The engine cranks but the engine does not start.

Go to Step 1 of "Problem 1".

2. Check the start/stop switch and slave relay (SR1).

- a. Disconnect the wire in the junction box that connects terminal (SR1-85) of the slave relay (SR1) to terminal (TD-7) of the time delay relay (TD).
- b. Crank the engine. Activate the emergency stop switch, if necessary.

Result

- The engine starts and the engine runs.

The start/stop switch has a short circuit or a wiring problem is causing a voltage at terminal (TD-7). Reconnect the wire to the terminal. STOP.

- Engine shutdown still occurs after several minutes.

The contacts of (SR1) periodically close. The problem may also be with the governor or the fuel supply to the engine. Refer to the Engine Service Manual. If a 2301A Electric Governor is used, the SR1 contacts may be opening. Refer to 2301A Electric Governor Service Manual, SENR3585. Test SR1. Refer to Testing and Adjusting, "Slave Relay Test".

Problem 6

Engine shutdown does not occur when a fault is detected.

1. Check the protection switches and the crank terminate switch of the electronic speed switch.
 - a. Reset circuit breaker (CB7).
 - b. Start the engine and run the engine at low idle.



WARNING

Contact with electrical components can cause injury or death.

Remove all jewelry and avoid contact with electrical components. Use properly insulated tools when working on the junction box of an engine.

NOTICE

If the contacts of the oil pressure switches do not close because of insufficient oil pressure, the ETS electric protection system will not arm. The engine cannot be stopped with the emergency stop switch (ES) or the start/stop switch. The engine must be stopped using a manual shutoff or by manually restricting the air inlet.

- c. Place the jumper across the correct terminals in order to isolate the protection switch for testing. Test only one switch at a time. Remove the jumper and test the next switch. Use the following order to test the switches.
- d. Place a jumper between terminals (TS-4) and (TS-8) of the junction box in order to test the oil pressure switch (OPS1). Conduct the test and remove the jumper.
- e. Place a jumper between terminals (TS-2) and (TS-7) of the junction box in order to test the water temperature contactor switch (WTS). Conduct the test and remove the jumper.

Result

- Engine shutdown occurs at low idle.

The engine protection system is operating correctly. Refer to Testing and Adjusting, "Engine Oil Pressure Switch Test" or Testing and Adjusting, "Water Temperature Contactor Switch Test". Replace the faulty switch. If the switches are not faulty, the circuit breaker (CB7) may have tripped. Inspect the circuit for a short circuit to ground. STOP.

- Engine shutdown does not occur at low idle.

The jumpers that are between terminals (TS-9) and (TS-10) have not been connected. The jumpers that are between terminals (TS-8) and (TS-9) have not been connected. The jumpers that are between terminals (TS-7) and (TS-8) have not been connected. Install all of the jumpers. Refer to Testing and Adjusting, "Diode Test". Replace a faulty diode. If the jumpers are installed correctly and the diode is not faulty go to Step 2.

2. Check the slave relay (SR1).
 - a. If a fuel shutoff solenoid (FSOS) is installed, measure the voltage at terminal (TS-30) of the junction box. If a 2301A Electric Governor is installed, measure the voltage at terminal (TS-31) of the junction box.

- b. While the engine is running, use a jumper on terminals (TS-2) and (TS-7) of the WTS to measure the voltages. Refer to Step 1 for the correct procedure.

Result

- The voltage on terminal (TS-30) is between 15 volts and 32 volts when the WTS is tested.

The slave relay (SR1) is not faulty. The fuel shutoff solenoid (FSOS) is faulty or the linkage for the fuel shutoff is jammed. Repair the faulty components. STOP.

- The voltage on terminal (TS-30) is zero or less than 15 volts when the WTS is tested.

The slave relay (SR1) is faulty or the circuit breaker (CB7) is open. Repair the faulty components. STOP.

Testing and Adjusting

i01078391

General Testing and Adjusting Information

SMCS Code: 7400

Introduction

The information in the Testing and Adjusting is a supplement to the Troubleshooting section of this Service Manual. The Troubleshooting section references several procedures in the Testing and Adjusting. The references are made when more detailed information is necessary in order to complete the diagnosis, the calibration, or the testing of a component.

The Abbreviations and Symbols section contains the following items that are used in the wiring drawings for the ETR electric protection system and the ETS electric protection system.

- Abbreviations
- Symbols
- Wiring sizes
- Wiring color
- Number codes

The section for the junction box arrangements contains the four types of electrical diagrams and the schematics that are listed below in order to describe each arrangement of the electric protection system.

- Junction box wiring diagram
- IEC (International Electro-Technical Commission) schematic
- JIC (Joint Industrial Council) schematic
- Diagram for the wiring harness in the junction box

Table 12

Speed Specification Chart							
Engine Model	No. of flywheel teeth	Typical Rated Engine Speeds		Functions of the Electronic Speed Switch ⁽¹⁾			
		Rated Engine RPM	Magnetic Pickup ⁽²⁾ Frequency (+ 25 Hz) Note C	Overspeed Setting (+ 25 rpm) Note A	75% Overspeed Verify (+ 25 rpm) Note B	Crank Termination Setting (rpm)	Oil Step Setting (rpm)
3200	126	2600 2800	5460 5880	3068 3304	2301 2478	400	1325
	134	1500 1800 2000 2200	3550 4020 4667 4913	1770 2124 2360 2596	1328 1593 1770 1947	400	1325
2400 2500 2600 2800		5360 5583 5807 6253	2832 2950 3068 3304	2124 2213 2301 2478			
3300	130	2200	4767	2596	1947	400	1250
	132	1400 1500 1800 2200	3080 3300 3960 4840	1652 1770 2124 2596	1239 1328 1593 1947	400	1125
		156	1400 1500 1800	3640 3900 4680	1652 1770 2124		
	2000 2100 2200		5200 5460 5720	2360 2478 2596	1770 1859 1947	1250	
3400	113	1000 1200 1300	1883 2260 2448	1180 1416 1534	885 1062 1151	400	750
		1500 1600	2825 3013	1770 1888	1328 1416		1350
		1750 1800	3296 3390	2065 2124	1549 1593		1125
		1900 2100	3578 3955	2242 2478	1682 1859		1250
	136	1000 1200	2267 2720	1180 1416	885 1062	400	750
		1500	3400	1770	1328		1125
		1800 2100	4080 4760	2124 2478	1593 1859		1350
343 346 348 349	140	1000 1200	2333 2800	1180 1416	885 1062	400	750
	151	1500 1800	3775 4530	1770 2124	1328 1593	400	1200
342	151	1000 1200	2517 3020	1180 1416	885 1062	400	800

(continued)

(Table 12, contd)

Speed Specification Chart							
Engine Model	No. of flywheel teeth	Typical Rated Engine Speeds		Functions of the Electronic Speed Switch ⁽¹⁾			
		Rated Engine RPM	Magnetic Pickup ⁽²⁾ Frequency (+ 25 hz) Note C	Overspeed Setting (+ 25 rpm) Note A	75% Overspeed Verify (+ 25 rpm) Note B	Crank Termination Setting (rpm)	Oil Step Setting (rpm)
353 379 398 399	151	1000 1200	2517 3020	1180 1416	885 1062	400	800
	183	1000 1200	3050 3660	1180 1416	885 1062	400	800
3500	151	1000	2517	1180	885	400	800
		1200	3020	1416	1062		
		1500	3775	1770	1328		
		1800	4530	2124	1593		
183	1000	3050	1180	885	400	800	
	1200	3660	1416	1062			
	1500	4575	1770	1328		1200	
1800	5490	2124	1593				
3600	255	900	3825	1020	765	170	750
		1000	4250	1130	850		650

(1) Input voltage: Maximum 40 VDC and Minimum 8 VDC.

(2) The magnetic pickup frequency (HZ) is calculated as follows: Frequency (HZ) = No. of flywheel teeth x (RPM setting/60)

i01076748

Crank Terminate Speed Calibration

SMCS Code: 1435-524; 7411-524

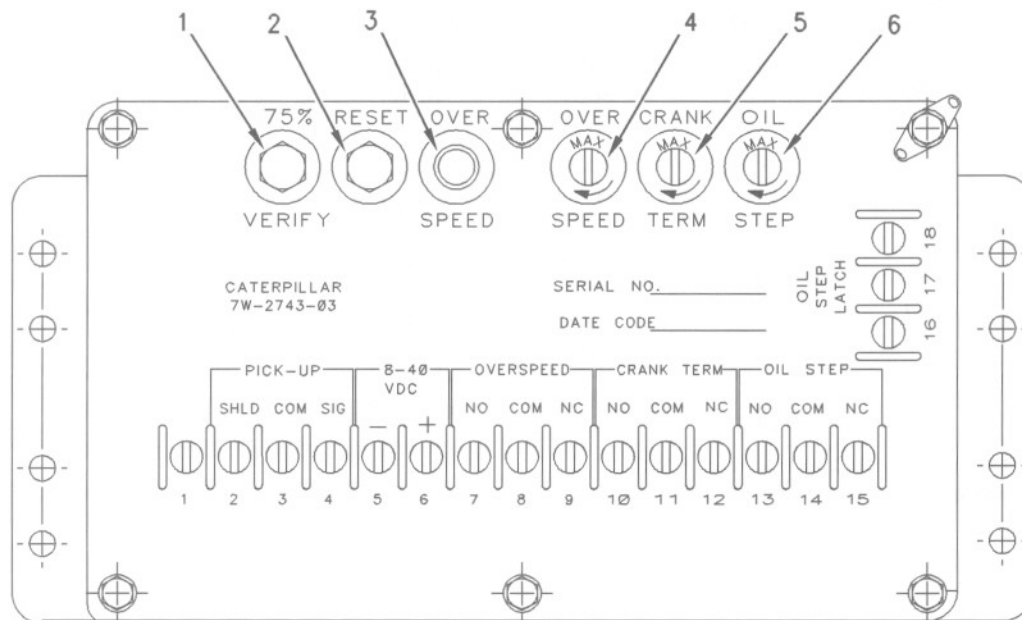

Illustration 66

g00564355

7W-2743 Electronic Speed Switch (ESS)

- | | | |
|--|---|---|
| (1) Push button for Overspeed Verification | (4) Seal screw plug for adjusting the engine overspeed | (6) Seal screw plug for adjusting the oil step pressure speed setting |
| (2) Reset button | | |
| (3) Overspeed indicator lamp | (5) Seal screw plug for adjusting the crank terminate speed | |

The calibration of the crank terminate adjustment can increase the crank terminate speed or the calibration of the crank terminate adjustment can decrease the crank terminate speed. The crank terminate speed determines when the starting motor is disengaged. The starting motor is disengaged when the system voltage is cancelled by the crank terminate speed. At the crank terminate speed, the engine must be able to run without the assistance of the starting motor.

1. Remove the lockwire and the seal from seal screw plug (5). Remove seal screw plug (5) from the access hole for the crank terminate adjusting screw.

2. Use a small screwdriver to lightly turn the crank terminate adjusting screw in the direction of the "MAX" arrow or the clockwise direction. Turn the screw twenty times. The crank terminate adjusting screw will vary the setting of a potentiometer that is inside of the ESS. The crank terminate adjusting screw will not cause damage to the potentiometer. Also, the screw can not be removed if the screw is turned in the wrong direction.

3. Turn the crank terminate adjusting screw for twelve turns in the opposite direction of the "MAX" arrow or the counterclockwise direction. This will establish an approximate crank terminate setting.

i01077495

4. Connect a voltmeter with the positive lead at terminal (ESS-12) and the negative lead at (ESS-5). Use a **6V-7070** Digital Multimeter or a voltmeter with the same accuracy. Start the engine. Record the engine rpm when the starting motor disengages. The starting motor disengages when the open circuit voltage is cancelled by the crank terminate setting. Refer to the Speed Specification Chart for the correct crank terminate setting.
5. If the setting in Step 4 is not correct, proceed with Steps 6, 7, and 8. If the setting is correct go to Step 8.
6. Stop the engine and turn the crank terminate adjusting screw for one full turn in the clockwise direction in order to increase the crank terminate speed. Turn the crank terminate adjusting screw for one full turn in the counterclockwise direction in order to decrease the crank terminate speed.
7. While the voltmeter is still connected, start the engine. Record the engine rpm when the starting motor disengages. The starting motor will disengage when the voltage is cancelled by the crank terminate speed. Repeat Steps 6 and 7 until the crank terminate speed is correct.
8. Install seal screw plug (5) in the access hole for the crank terminate adjusting screw. Tighten the screw to a torque of 0.20 ± 0.03 N·m ($1.8 \pm .3$ lb in). Install the lockwire and the seal if the overspeed calibration and the oil step speed calibration are also complete.

i01077490

Diode Test

SMCS Code: 1400-081; 1435-081

The diode test will determine if the diode is defective and if the diode needs to be replaced. Use the **6V-7070** Digital Multimeter for the test. Set the multimeter to the position for the diode test. Disconnect the diode from the circuit.

1. Connect the positive lead of the multimeter to one end of the diode. Connect the negative lead of the multimeter to the opposite end. Record the reading on the multimeter.
2. Reverse the connections of the multimeter on the diode. Record the reading on the multimeter.

If the multimeter reading was high on one test and low on the opposite test, the diode is not defective. If the multimeter reading was high or low on both of the tests, the diode is defective and the diode needs to be replaced.

Engine Oil Pressure Switch Test

SMCS Code: 1924-081

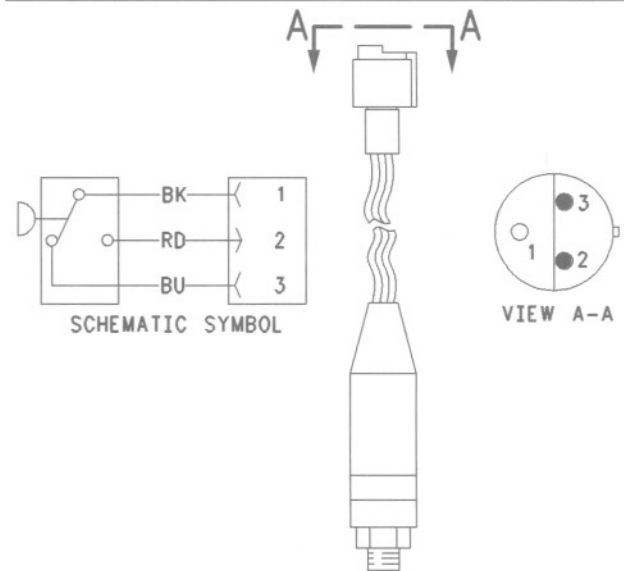

Illustration 67

g00564916

The test for the engine oil pressure switch is a test for the actuation of the engine oil pressure and a test for the electrical continuity. This test will determine if the engine oil pressure switch is faulty and if the engine oil pressure switch needs to be replaced. Use the **1U-5470** Engine Pressure Group and the **8T-0500** Continuity Tester for this test.

1. If an access hole that has the same engine oil pressure as the engine oil pressure switch is not close to the engine oil pressure switch, remove the engine oil pressure switch. Install a tee at this location. Install the engine oil pressure switch on one side of the tee, and connect the **1U-5470** Engine Pressure Group on the opposite side of the tee.

Note: This test can also be performed on a bench with air pressure if the correct fittings are available.

2. Disconnect the connector for the engine oil pressure switch from the junction box. While the engine is stopped, check the continuity between contact (2) and common contact (1). The continuity should be open. Next, check the continuity between contact (3) and common contact (1). This continuity should be closed.

3. Start the engine and allow the engine to run. Observe the 8T-0500 Continuity Tester and the 1U-5470 Engine Pressure Group from the time that the engine is started until the engine is running. The continuity between contact (2) and common contact (1) should close when the engine oil pressure is greater than the deactuation pressure of the engine oil pressure switch.

The engine should begin to run and the starting motor should disengage when the engine oil pressure is above the deactuation pressure of the engine oil pressure switch. Record the reading from the pressure gauge when the continuity of the engine oil pressure switch changes. Compare the reading with the specifications for the deactuation pressure of the engine oil pressure switch.

4. The engine oil pressure switch should close across contact (2) and common contact (1) when the engine oil pressure is above the specified deactuation pressure of the engine oil pressure switch. If the engine oil pressure switch does not close the engine oil pressure switch is faulty. Replace the faulty switch.

i01077486

Magnetic Pickup Test

SMCS Code: 1907-081

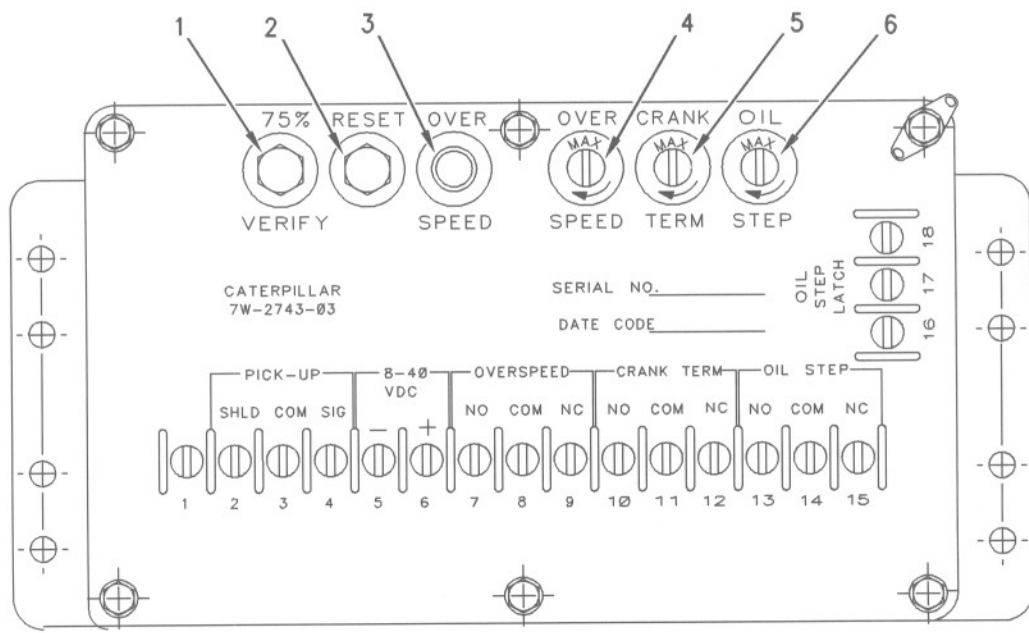

Illustration 68
7W-2743 Electronic Speed Switch (ESS)

g00564355

- (1) Push button for Overspeed Verification
- (2) Reset button
- (3) Overspeed indicator lamp
- (4) Seal screw plug for adjusting the engine overspeed
- (5) Seal screw plug for adjusting the crank terminate speed
- (6) Seal screw plug for adjusting the oil step pressure speed setting

The procedure for the magnetic pickup test will determine if the operation of the magnetic pickup is correct.

1. Connect a 6V-7070 Digital Multimeter to the "COM" terminal and the "SIG" terminal. The terminals are (ESS-3) and (ESS-4) of the ESS. Set the meter voltage scale to a scale that is greater than 1.5 VAC. Start the engine. Run the engine at low idle or 600 rpm. Choose the one that is larger.

2. Stop the engine. Disconnect the wiring for the magnetic pickup at the plug-in connector. Connect the voltmeter to the connector terminals of the magnetic pickup. Start the engine. Run the engine at low idle or 600 rpm. Choose the one that is larger.

If the voltage that is measured is 1.5 VAC or more, repair the wiring that is between the magnetic pickup and the ESS. If the voltage is less than 1.5 VAC, go to Step 3.

If the voltage that is measured is 1.5 VAC or more, the operation of the magnetic pickup is correct. If the voltage is less than 1.5 VAC, go to Step 2.

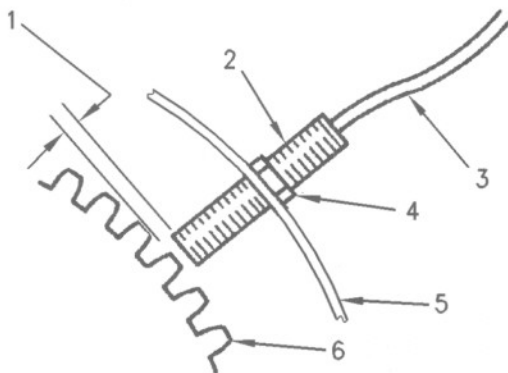

Illustration 69

g00564913

Magnetic pickup

- (1) Clearance
- (2) Magnetic pickup
- (3) Wires to the connector
- (4) Locknut
- (5) Flywheel housing
- (6) Ring gear

3. Loosen locknut (4) and turn magnetic pickup (2) in the counterclockwise direction in order to remove magnetic pickup (2) from flywheel housing (5). Turn the flywheel until a gear tooth of ring gear (6) is directly in the center of the threaded hole for magnetic pickup (2). Install magnetic pickup (2) in flywheel housing (5).
4. Turn magnetic pickup (2) in the clockwise direction until the end of magnetic pickup (2) slightly touches the gear tooth. Turn the magnetic pickup for one-half turn in the counterclockwise direction in order to set correct clearance (1). Tighten locknut (4) to a torque of 45 ± 7 N·m (33 ± 5 lb ft).

Note: Do not allow the magnetic pickup to turn while the locknut is tightened.

5. Repeat Step 2. If the voltage is still less than 1.5 VAC, replace the magnetic pickup.

i01077277

Oil Step Speed Calibration

SMCS Code: 1435-524

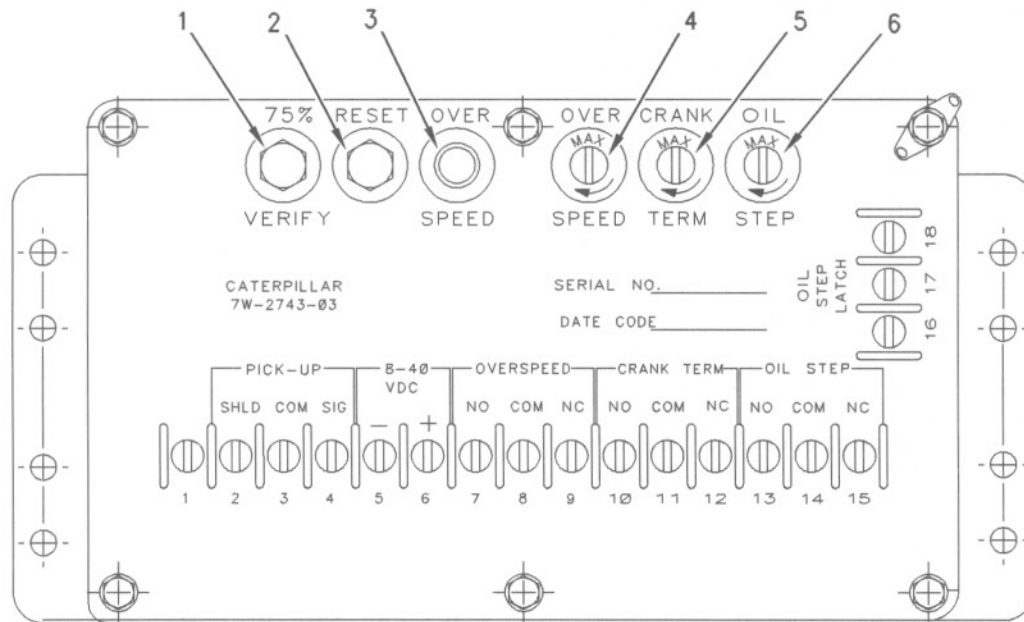

Illustration 70

g00564355

7W-2743 Electronic Speed Switch (ESS)

- | | | |
|--|---|---|
| (1) Push button for Overspeed Verification | (4) Seal screw plug for adjusting the engine overspeed | (6) Seal screw plug for adjusting the oil step pressure speed setting |
| (2) Reset button | (5) Seal screw plug for adjusting the crank terminate speed | |
| (3) Overspeed indicator lamp | | |

The oil step speed calibration increases the oil step speed setting or the oil step speed calibration decreases the oil step speed setting. Refer to the Speed Specification Chart in order to find the oil step speed that is equal to the engine rpm when the engine is running.

1. Remove the lockwire and the seal from seal screw plug (6). Remove seal screw plug (6) from the access hole for the oil step speed adjusting screw.

2. Use a small screwdriver to lightly turn the oil step speed adjusting screw in the direction of the "MAX" arrow or the clockwise direction. Turn the screw twenty times. The oil step speed adjusting screw will vary the setting of a potentiometer that is inside of the ESS. The oil step speed adjusting screw will not cause damage to the potentiometer. Also, the screw can not be removed if the screw is turned in the wrong direction.

3. Connect a voltmeter with the positive lead at terminal (ESS-13) and the negative lead at (ESS-5). Use a 6V-7070 Digital Multimeter or a voltmeter with the same accuracy. Measure the voltage.

4. For a specific engine rating, find the engine rpm in the column for the oil step speed setting in the Speed Specification Chart. Run the engine at the rpm that is specified in the table.
5. While the engine is running, look into the hole for the adjustment of the oil step speed. A red indicator lamp should be lighted. A positive voltage should be observed on the multimeter 9 seconds after the indicator lamp is lighted. Turn the oil step speed adjusting screw clockwise until the indicator lamp turns off. The oil step speed setting is above the present rpm of the engine. Slowly turn the oil step speed adjusting screw counterclockwise until the indicator lamp is lighted. After a 9 second delay, a positive voltage should be observed on the multimeter. This position is the correct setting for the oil step speed.
6. Install seal screw plug (6) in the access hole for the oil step speed adjusting screw. Tighten the screw to a torque of 0.20 ± 0.03 N·m ($1.8 \pm .3$ lb in). Install the lockwire and the seal if the overspeed calibration and the crank terminate speed calibration are also complete.

i01076649

Overspeed Calibration

SMCS Code: 1435-524; 7427-524

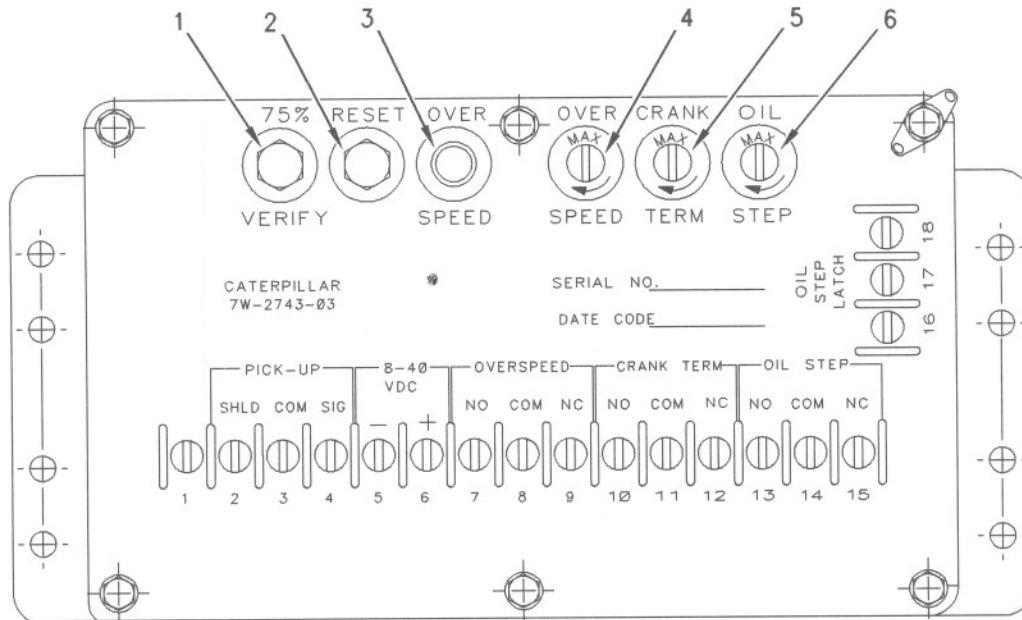

Illustration 71

g00564355

7W-2743 Electronic Speed Switch (ESS)

- | | | |
|---|---|--|
| <p>(1) Push button for Overspeed Verification
(2) Reset button
(3) Overspeed indicator lamp</p> | <p>(4) Seal screw plug for adjusting the engine overspeed
(5) Seal screw plug for adjusting the crank terminate speed</p> | <p>(6) Seal screw plug for adjusting the oil step pressure speed setting</p> |
|---|---|--|

The overspeed calibration can increase the overspeed setting or the overspeed calibration can decrease the overspeed setting in order to shut down the engine when the overspeed verification button is pressed. The overspeed setting is correctly made when the engine is running at 75% of the overspeed setting. The engine then shuts down when the overspeed verification button is pressed.

Use the following procedure in order to adjust the overspeed setting.

1. Remove the lockwire and the seal from seal screw plug (4). Remove seal screw plug (4) from the access hole for the overspeed adjustment screw.

2. Use a small screwdriver to lightly turn the overspeed adjustment screw in the direction of the "MAX" arrow or the clockwise direction. Turn the screw 20 times. The overspeed adjustment screw will vary the setting of a potentiometer that is inside of the ESS. The overspeed adjustment screw will not cause damage to the potentiometer. Also, the screw can not be removed if the screw is turned in the wrong direction.
3. Run the engine at 75% of the desired overspeed setting rpm. Refer to the Speed Specification Chart.

4. While the engine is running at 75% of the overspeed setting rpm, press "VERIFY" button (1). While the button is depressed, slowly turn the overspeed adjustment screw in the opposite direction of the "MAX" arrow or the counterclockwise direction until overspeed indicator lamp (3) is lighted. The engine will shut down if the ESS is connected to the fuel shutoff solenoid (FSOS) and the air shutoff solenoid, if equipped.
5. In order to reset the ESS, press "RESET" button (2). The air shutoff valve must be reset by hand, if equipped.
6. Slowly turn the overspeed adjustment screw in the clockwise direction for one turn. Repeat Steps 3, 4, and 5. More adjustment may be necessary in order to gain the correct setting. Turn the overspeed adjustment screw in the clockwise direction in order to increase the overspeed setting. Turn the overspeed adjustment screw in the counterclockwise direction in order to decrease the overspeed setting.
7. When the overspeed setting is correct, install seal screw plug (4) in the access hole for the overspeed adjustment screw. Tighten the screw to a torque of 0.20 ± 0.03 N·m ($1.8 \pm .3$ lb in). Install the lockwire and the seal if the calibration of the crank termination speed and the oil step speed calibration are also complete.

i01076455

Overspeed Verification Test

SMCS Code: 1435-081; 7427-081

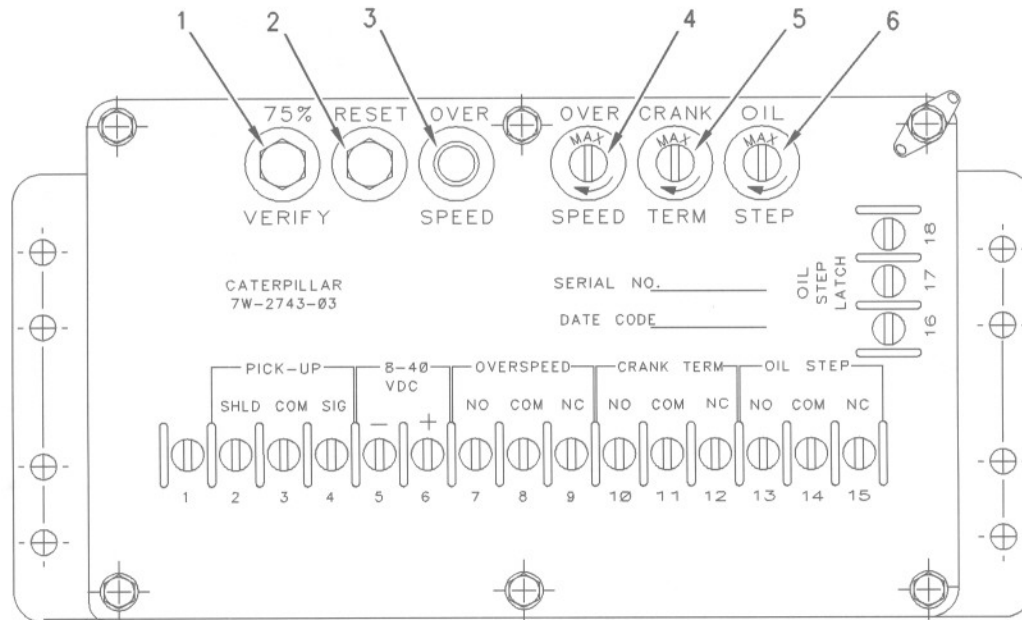

Illustration 72

g00564355

7W-2743 Electronic Speed Switch (ESS)

- | | | |
|--|---|---|
| (1) Push button for Overspeed Verification | (4) Seal screw plug for adjusting the engine overspeed | (6) Seal screw plug for adjusting the oil step pressure speed setting |
| (2) Reset button | (5) Seal screw plug for adjusting the crank terminate speed | |
| (3) Overspeed indicator lamp | | |

The Overspeed Verification Test ensures that the overspeed switch in the electronic speed switch will cause engine shutdown when the engine is running at 75% or more of the overspeed setting.

Run the engine at the rated speed and press the overspeed verification button (1) for a moment. The button energizes the switch which causes the engine to shutdown. When the engine rpm is 75% or more of the overspeed setting, engine shutdown should occur when the button is pressed. The engine overspeed setting is 118% of the rated engine rpm.

This is an example of calculating the correct engine overspeed setting. An engine with a rated speed of 1800 rpm has an overspeed setting of 2125 rpm. Refer to the Speed Specification Chart. The overspeed verification test will cause engine shutdown at 75% of the overspeed setting. The overspeed setting is 118% of the rated engine rpm. In this example, 75% of 2125 is 1594 rpm. When the engine speed is 1594 ± 25 rpm or more and the overspeed verification button is pressed, the engine will shut down.

After engine shutdown because of engine overspeed, the overspeed indicator lamp (3) will remain on until reset button (2) is pressed. Before you start the engine, press reset button (2) for a moment. The overspeed indicator lamp (3) will turn off. The air inlet shutoff lever and the emergency stop switch (ES) must also be reset before the engine can be started.

i01077550

Slave Relay Test

SMCS Code: 1400-081-R7; 1435-081

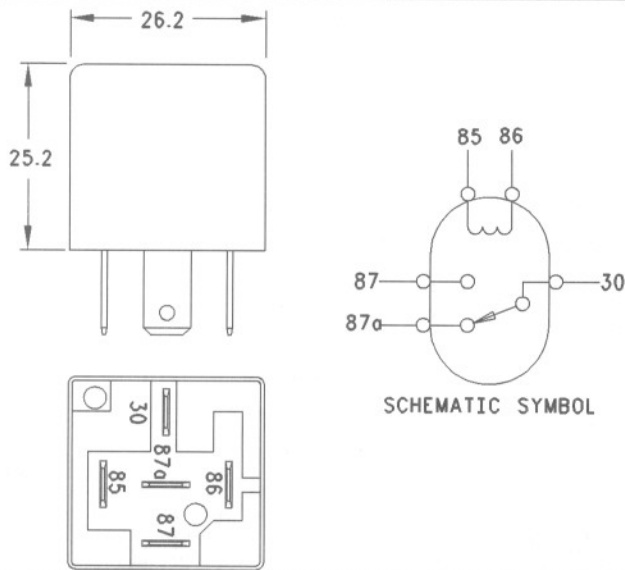

Illustration 73

g00564929

9X-4276 Relay

The slave relay test will determine if the contacts of the internal switch are shorted across the contacts of terminals (SR-87) and (SR-87a). One contact is normally closed and the other contact is normally open when the slave relay is not energized. Use a 6V-7070 Digital Multimeter to test the slave relay.

1. Remove the relay from the junction box. Connect the negative lead of a 24 volt source to terminal (SR-86) and connect the positive lead to terminal (SR-30).
2. Place the negative lead of the multimeter on terminal (SR-86) and place the positive lead of the multimeter on terminal (SR-87a). The voltage should be 24 Volts.
3. Place the negative lead of the multimeter on terminal (SR-86) and place the positive lead of the multimeter on terminal (SR-87). The voltage should be zero.
4. Place a jumper across terminals (SR-30) and (SR-85). Place the negative lead of the multimeter on terminal (SR-86) and place the positive lead of the multimeter on terminal (SR-87a). The voltage should be zero.
5. Place the negative lead of the multimeter on terminal (SR-87) and place the positive lead of the multimeter on terminal (SR-86). The voltage should be 24 volts.

6. If any of the multimeter readings are incorrect, the relay is faulty and the relay should be replaced.

i01077942

Water Temperature Contactor Switch Test

SMCS Code: 1906-081

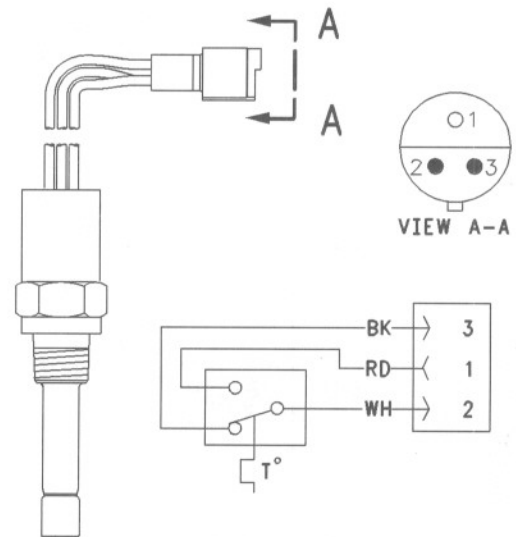

Illustration 74

g00565249

The test for the water temperature contactor switch is a test for the temperature on the switch actuator and an electrical continuity test. This test will determine if the water temperature contactor switch is faulty and if the switch should be replaced. Use the 4C-6500 Digital Thermometer and the 4C-6500 Digital Thermometer for this test.

1. Install a probe from the 4C-6500 Digital Thermometer in the water manifold as close as possible to the water temperature contactor switch. Disconnect the connector for the water temperature contactor switch from the junction box.

Note: Do not remove the water temperature contactor switch from the engine in order to conduct this test. The water temperature contactor switch uses the coolant flow and the coolant temperature in order to activate the switch at the actuation temperature.

i01078321

2. When the water temperature contactor switch is disconnected from the junction box and the engine is stopped, check the continuity across the contact (WTS-3) and the common contact (WTS-2). Continuity should exist. This indicates that the circuit is closed across the contacts. Check the continuity across contact (WTS-1) and the common contact (WTS-2). Continuity should not exist. This indicates that the circuit is open across the contacts. If these conditions do not exist, the water temperature contactor switch is faulty and the switch needs to be replaced.
3. Start the engine. While the engine is running, place a load on the engine. Restrict the air flow to the engine. The engine should continue to run and the coolant temperature should increase to the actuation temperature of the water temperature contactor switch.
4. Observe the coolant temperature gauge in order to determine the temperature of the coolant when the actuation of the switch occurs. Compare the temperature on the gauge with the specifications for the water temperature contactor switch. The switch is actuated when the circuit across contacts (WTS-1) and (WTS-2) closes. The engine should shut down when the switch is actuated. This activates the protection system.
5. The actuation of the water temperature contactor switch may not occur when the temperature of the coolant is greater than the maximum value for the actuation temperature of the switch. Immediately reduce the load that is on the engine and remove the restriction to the air inlet. Allow the engine to run at idle until the temperature of the coolant returns to normal before you stop the engine.
6. The actual temperature of the coolant may not have been within the specifications of the water temperature contactor switch at the time of actuation. The switch is faulty and the switch needs to be replaced. Actuation might not occur when the temperature of the coolant is at the maximum. The switch is faulty and the switch needs to be replaced.

Time Delay Relay Verification Test

SMCS Code: 1400-081-R7; 1435-081

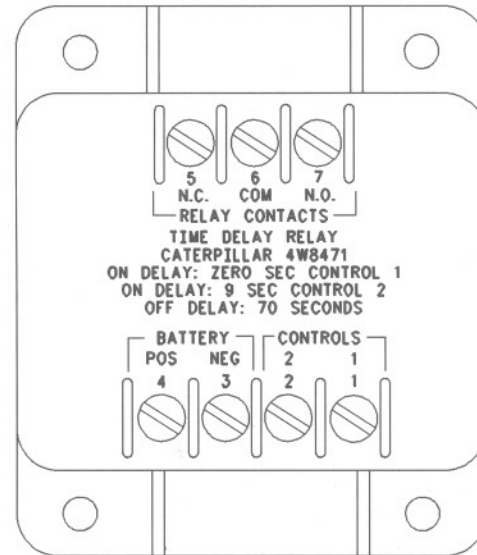

Illustration 75

g00565418

4W-8471 Time Delay Relay

1. Use a 6V-7070 Digital Multimeter, a stopwatch, and a battery (8 volts to 40 volts) for this test.
2. Connect the positive lead of the voltage source to terminal (TD-4) of the time delay relay. Connect the negative lead to terminal (TD-3). If the test is done on an engine, the start/stop switch must be in the STOP position in order to power terminal (TD-6). All connections must be maintained until the tests are completed.
3. Use the multimeter to determine continuity. Compare the measurements to the following table.

Table 13

Terminals	Relay Position
5-6	Closed
6-7	Open

4. Connect the positive lead of the voltage source to terminal (TD-1). If the time delay relay is tested on the engine do not leave the voltage source hooked to terminal (TD-1) for more than 60 seconds. The fuel shutoff solenoid will be energized. Use the multimeter to determine continuity. Compare the measurements to the following table.

Table 14

Terminals	Relay Position
5-6	Open
6-7	Closed

5. Remove the positive lead of the voltage source from terminal (TD-1). Use the stopwatch to measure the time that is needed for the position of the relay to change. Use the multimeter to determine continuity. Compare the measurements to the following table.

Table 15

Terminals	Delay Time of Relay Position	
	0 to 60 seconds	80 seconds or more
5-6	Open	Closed
6-7	Closed	Open

Note: If a jumper is normally installed across terminals (TD-2) and (TD-3), the jumper must be removed before performing Step 5.

6. Connect the positive lead of the voltage source to terminal (TD-2). If the time delay relay is tested on the engine, do not leave the voltage source on terminal (TD-2) for more than 60 seconds. The fuel shutoff solenoid will be energized. Use the stopwatch to measure the time that is needed for the position of the relay to change. Use the multimeter to determine continuity. Compare the measurements to the following table.

Table 16

Terminals	Delay Time of Relay Position	
	0 to 8 seconds	10 seconds or more
5-6	Closed	Open
6-7	Open	Closed

7. Remove the positive lead of the voltage source from terminal (TD-1). Use the stopwatch to measure the time that is needed for the position of the relay to change. Use the multimeter to determine continuity. Compare the measurements to the following table.

Table 17

Terminals	Delay Time of Relay Position	
	0 to 60 seconds	80 seconds or more
5-6	Open	Closed
6-7	Closed	Open

8. Remove the voltage source from terminal (TD-4). Use the multimeter to determine continuity. Compare the measurements to the following table.

Table 18

Terminals	Relay Position
5-6	Closed
6-7	Open

Index

- A**
- Abbreviations and Symbols 66
 - Description of Electrical System Symbols And Codes..... 66
 - Introduction..... 66
- C**
- Crank Terminate Speed Calibration..... 94
- D**
- Diode Test..... 95
- E**
- Electric Protection System Functional Test..... 75
 - Test 1 - Overspeed Switch (OS)..... 76
 - Test 2 - Emergency Stop Switch (ES)..... 76
 - Test 3 - Normal Stop Switch (NSS)..... 76
 - Test 4 - Water Temperature Contactor Switch... 76
 - Test 5 - Oil Pressure Switch (OPS1)..... 77
 - Test 6 - Oil Pressure Switch (OPS2)..... 77
 - Engine Oil Pressure Switch Test..... 95
 - ETS Component Descriptions..... 5
 - 2301A Electric Governor Control..... 10
 - Air Shutoff Solenoid (ASOS)..... 9
 - Battery Discharge By The Electric Protection System..... 11
 - Circuit Breakers (CB)..... 9
 - Electronic Speed Switch (ESS)..... 5
 - Fuel Shutoff Solenoid (FSOS)..... 10
 - Magnetic Pickup (MPU)..... 7
 - Oil Pressure Switch (OPS)..... 7
 - Slave Relay (SR)..... 8
 - Starting Aid Switch (SAS)..... 8
 - Time Delay Relay (TD)..... 10
 - Water Temperature Contactor Switch (WTS)..... 8
 - ETS Introduction..... 4
 - ETS Junction Box-Switchgear Not Required (OP,WT)..... 53
 - 2301A Electric Governor Control..... 58
 - Circuit Operation With No Faults..... 54
 - Electrical Schematics And Wiring Diagrams..... 54
 - Fault Circuit Operation..... 57
 - Introduction..... 54
 - ETS Junction Box-Switchgear Not Required (OP,WT,OS)..... 33
 - 2301A Electric Governor Control..... 41
 - Circuit Operation With No Faults..... 35
 - Electrical Schematics And Wiring Diagrams..... 35
 - Fault Circuit Operation..... 39
 - Introduction..... 35
- ETS Junction Box-Switchgear Required (OP,WT,OS)..... 13
 - 2301A Electric Governor Control..... 22
 - Circuit Operation With No Faults..... 16
 - Electrical Schematics And Wiring Diagrams..... 16
 - Fault Circuit Operation..... 19
 - Introduction..... 16
- G**
- General Testing and Adjusting Information..... 91
 - Introduction..... 91
 - General Troubleshooting Information..... 75
 - Introduction..... 75
- I**
- Important Safety Information..... 2
- J**
- Junction Box and Enclosure Group..... 12
- M**
- Magnetic Pickup Test..... 97
- O**
- Oil Step Speed Calibration..... 99
 - Overspeed Calibration..... 101
 - Overspeed Verification Test..... 103
- S**
- Slave Relay Test..... 104
 - Systems Operation Section..... 4
- T**
- Table of Contents..... 3
 - Testing and Adjusting..... 91
 - Testing and Adjusting Section..... 75
 - Time Delay Relay Verification Test..... 105
 - Troubleshooting..... 75

Troubleshooting the ETS Full Protection System
(OP, WT, OS)..... 77
 Problem 1..... 77
 Problem 2..... 80
 Problem 3..... 81
 Problem 4..... 81
 Problem 5..... 82
 Problem 6..... 83
Troubleshooting the ETS Partial Protection System
(OP, WT) (3200-3400 Engines)..... 85
 Problem 1..... 85
 Problem 2..... 86
 Problem 3..... 87
 Problem 4..... 88
 Problem 5..... 88
 Problem 6..... 89

W

Water Temperature Contactor Switch Test..... 104