

C **GENERATOR MOUNTED CONTROL PANEL**

(TYPE 5 — CHANGE LEVEL 12)

INTRODUCTION

The uses of the generator mounted control panel are:

To help control the electric power made by the generator set.

To monitor (check) the operation of the generator set.

To help protect the generator set from damage caused by low oil pressure, high coolant temperature, overspeed and overcrank.

To help with the transfer of electrical load to and from the generator set.

To help parallel two or more units onto the same bus.

IDENTIFICATION

The location of the control panel is on the top of the regulator housing. This panel has a place for a heat switch and prealarm module. The shutdown indicators are relay lamp type. The control panel has a 13 place model number on the panel nameplate located inside bottom surface of control panel. The model number gives an indication of the control panel component part numbers. Make reference to the Parts Book, GENERATOR MOUNTED CONTROL PANEL, Form No. SEBP1068. The last two digits of the model number are the change level to which the panel was built.

WIRING

See the pages that follow for wiring diagrams, schematics and photographs for identification.

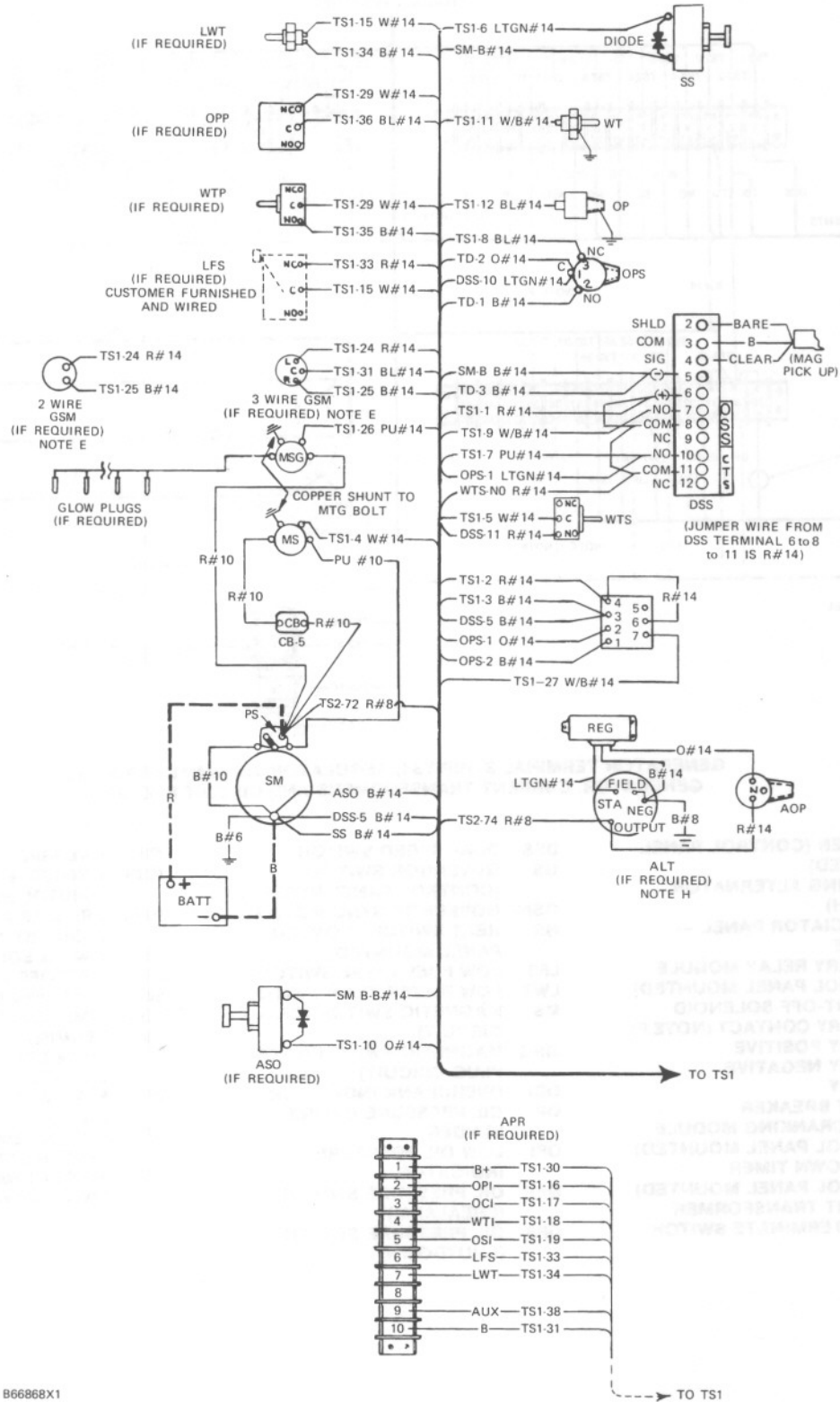

866868X1

REMOTE AND ENGINE MOUNTED ELECTRICAL COMPONENTS

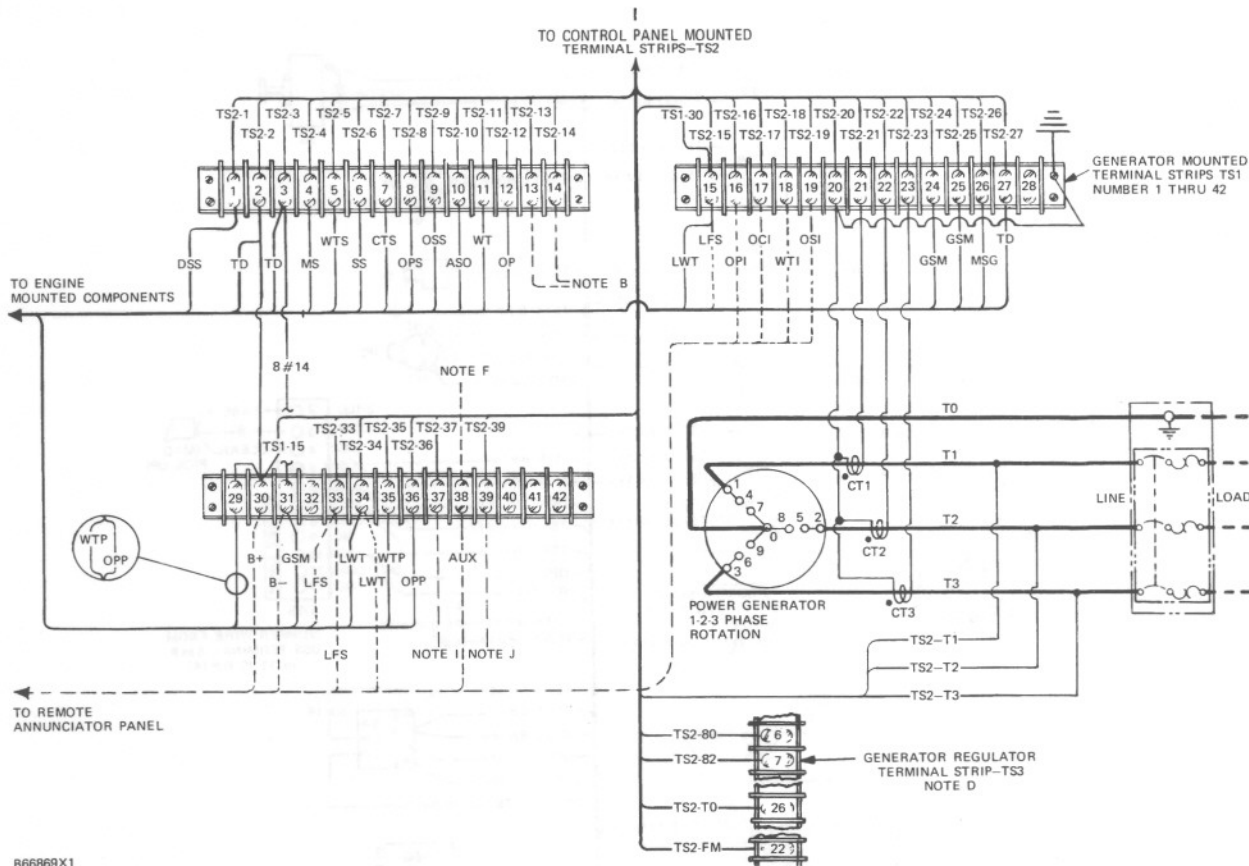

GENERATOR TERMINAL STRIP TS1, REGULATOR TERMINAL STRIP TS3, GENERATOR, CURRENT TRANSFORMERS AND CIRCUIT BREAKER.

- | | | | | | |
|------|--|-----|---|-----|---|
| A | AMMETER (CONTROL PANEL MOUNTED) | DSS | DUAL SPEED SWITCH | OSI | OVERSPEED INDICATOR |
| ALT | CHARGING ALTERNATOR (NOTE H) | GS | GOVERNOR SWITCH (CONTROL PANEL MOUNTED) | OSS | OVERSPEED SWITCH (SHUTDOWN) |
| APR | ANNUNCIATOR PANEL — REMOTE | GSM | GOVERNOR SYNC MOTOR | PAM | PREALARM MODULE (CONTROL PANEL MOUNTED) |
| ARX | AUXILIARY RELAY MODULE (CONTROL PANEL MOUNTED) | HS | HEAT SWITCH (CONTROL PANEL MOUNTED) | PS | PINION SOLENOID |
| ASO | AIR SHUT-OFF SOLENOID | LFS | LOW FUEL LEVEL SWITCH | SS | SHUTOFF SOLENOID |
| AUX | AUXILIARY CONTACT (NOTE F) | LWT | LOW WATER TEMP SWITCH | SM | STARTING MOTOR |
| B+ | BATTERY POSITIVE | MS | MAGNETIC SWITCH (CRANK CIRCUIT) | TD | TIME DELAY RELAY |
| B- | BATTERY NEGATIVE | MSG | MAGNETIC SWITCH (GLOW PLUG CIRCUIT) | TS | TERMINAL STRIP |
| BATT | BATTERY | OPP | OIL PRESSURE SWITCH (PREALARM) | WT | WATER TEMPERATURE GAGE SENDER |
| CB | CIRCUIT BREAKER | OPS | OIL PRESSURE SWITCH (SHUTDOWN) | WTI | HIGH WATER TEMPERATURE INDICATOR |
| CCM | CYCLE CRANKING MODULE (CONTROL PANEL MOUNTED) | | | WTP | WATER TEMPERATURE SWITCH (PRE-ALARM) |
| CDT | COOL DOWN TIMER (CONTROL PANEL MOUNTED) | | | WTS | WATER TEMPERATURE SWITCH (SHUTDOWN) |
| CT | CURRENT TRANSFORMER | | | | |
| CTS | CRANK TERMINATE SWITCH | | | | |

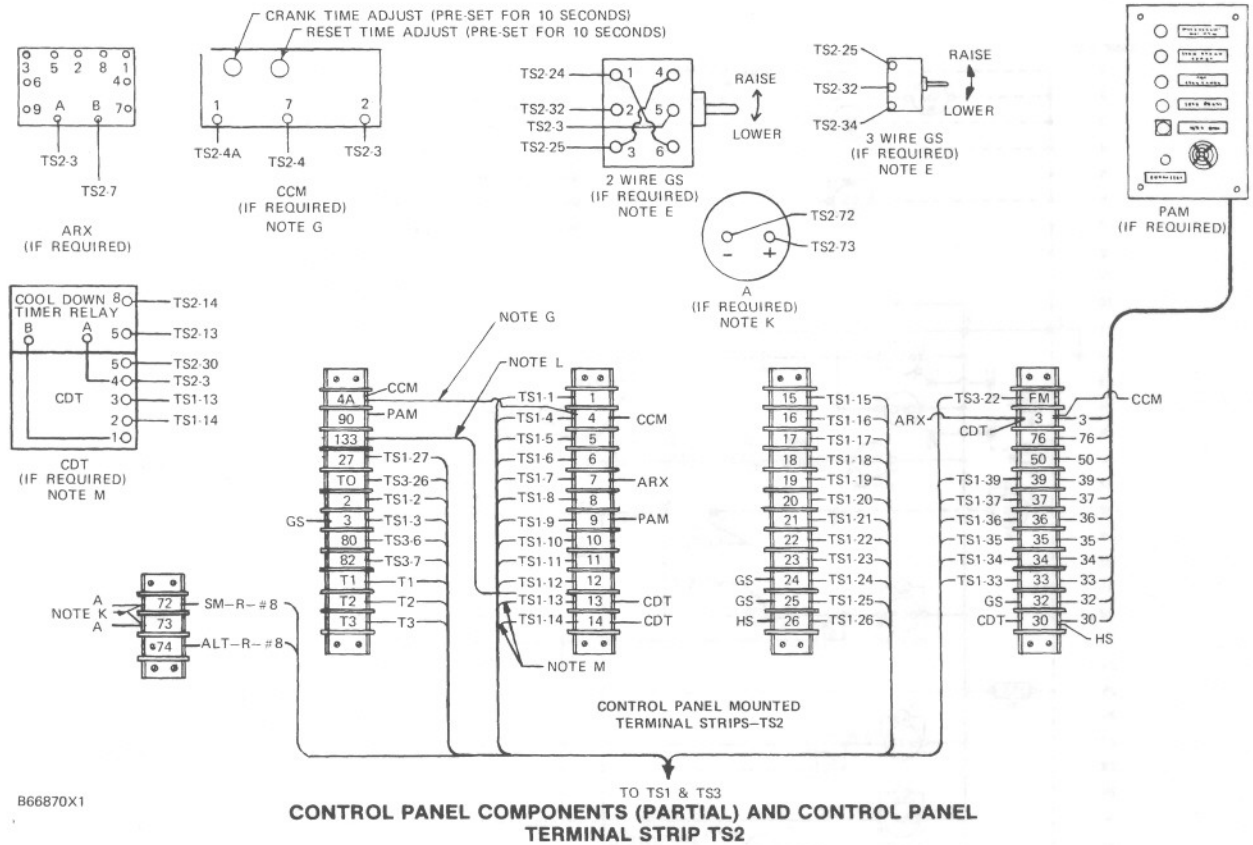

B66870X1

NOTE A: Wire and cable shown dotted to be furnished by customer.

NOTE B: To be wired to engine starting contact (N.O.) in auto transfer switch by customer.

NOTE C: Each wire on terminal strip is identified on each end — corresponding to terminal strip number.

NOTE D: Remove yellow wire and insulate from terminal 7 at TS3 before connecting wire from TS2.

NOTE E: Use 3 wire diagram with Bodine 3 wire synchronizing motor. Use 2 wire diagram with 2 wire permanent magnet motor.

NOTE F: To be wired to auxiliary contact (N.O.) on emergency side of transfer switch. Required only when optional generator set annunciator panel (remote) is provided. (Generating indication).

NOTE G: Red jumper wire from TS2-4A to TS2-4 must be removed when cycle cranking module is used.

NOTE H: Do not operate alternator without a battery connected in the system. Do not polarize alternator. Do not operate alternator simultaneously with a DC generator to charge a common battery.

NOTE I: Provides 24 volts for remote low oil pressure (pre-alarm) (OPP) indication when pre-alarm module is used.

NOTE J: Provides 24V for customer provided remote shutdown and pre-alarm indicator when pre-alarm module is used.

NOTE K: Jumper wire from TS2-72 to TS2-73 must be removed when ammeter is used.

NOTE L: Jumper wire from TS2-13 to TS2-133 to be removed if additional fault shutdowns are added. Example: Reverse power relay or remote shutdown.

NOTE M: When adding the engine cool down timer option, wires from TS1-13 and TS1-14 should be reconnected to CDT-3 and CDT-2.

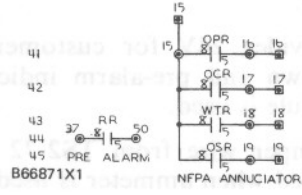
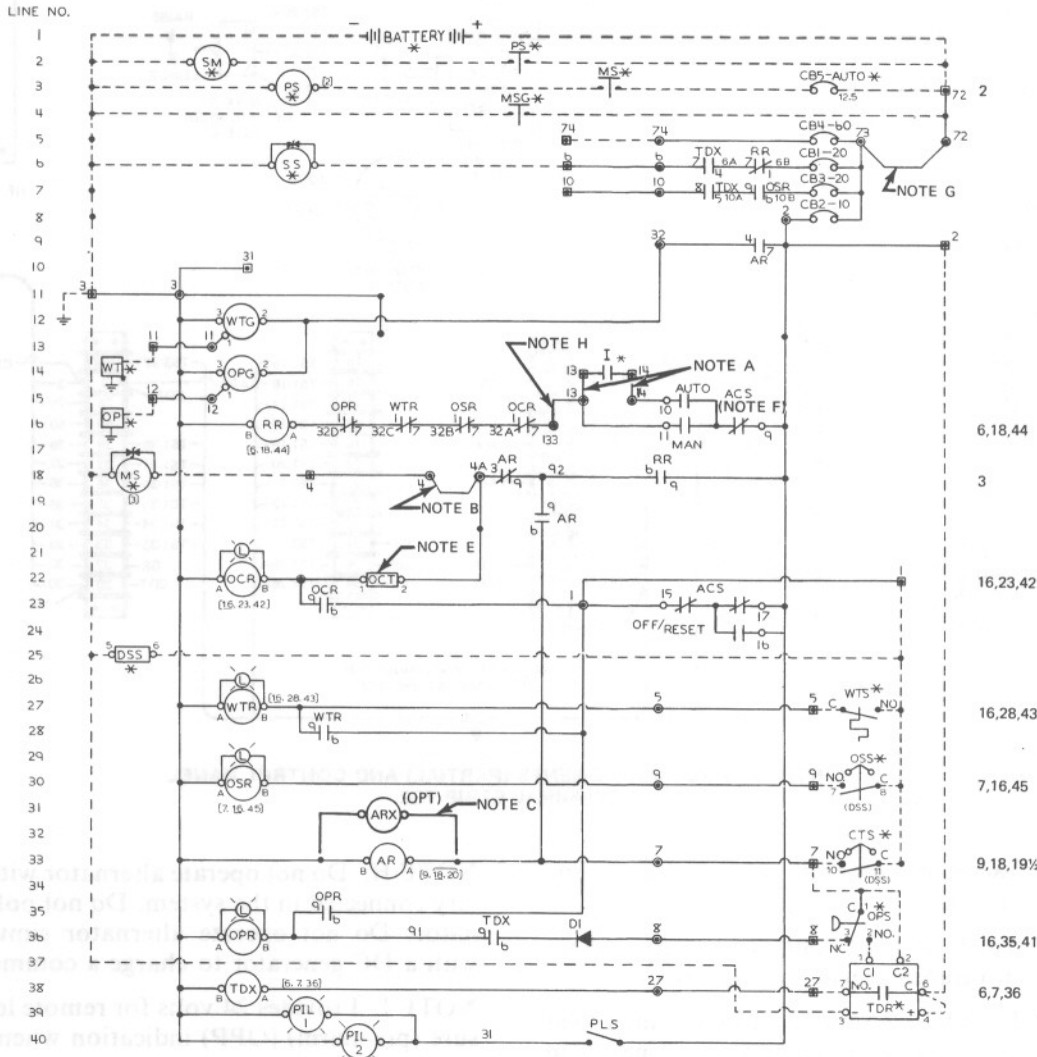

- NOTE A. TERMINALS 13 & 14 OF THE GENERATOR BOX WILL BE CONNECTED TO TERM 13 & 14 OF THE CONTROL PANEL WHEN THE COT IS NOT SUPPLIED
- NOTE B. RED JUMPER WIRE FROM TERMINAL STRIP POINT NUMBER 4A TO 4 IN CONTROL PANEL MUST BE REMOVED WHEN THE CYCLE CRANKING MODULE (CCM) IS USED
- NOTE C. AUXILIARY RELAY (ARX) CONTACTS ARE TO BE CUSTOMER WIRED. SEE RELAY CONTACT SCHEMATIC
- NOTE D. ALL ENGINE WIRING SHOWN AS DOTTED LINES
- NOTE E. THE OVERCRANK TIMER (OCT) IS TO BE ADJUSTED TO THE 30 SECOND SET POINT (RED DOT). WHEN CYCLE CRANKING (CCM) IS USED THE OVERCRANK TIMER (OCT) IS TO BE ADJUSTED TO THE 90 SECOND SETPOINT (WHITE DOT).
- NOTE F. ACS SWITCH CONTACTS SHOWN WITH SWITCH IN AUTO POSITION
- NOTE G. JUMPER WIRE FROM TERMINAL 72 TO TERMINAL 73 MUST BE REMOVED WHEN DC AMMETER (A) IS USED
- NOTE H. JUMPER WIRE FROM TERMINAL 13 TO TERMINAL 133 TO BE REMOVED IF ADDITIONAL FAULT SHUTDOWNS ARE ADDED. EXAMPLES: REVERSE POWER RELAY OR REMOTE SHUTDOWN, INSERT A NORMALLY CLOSED SWITCH BETWEEN TERMINAL 13 AND TERMINAL 133.

- | | | |
|---|--|--|
| AR ARMING RELAY | OP OIL PRESSURE GAUGE SENDER | SR SHUTDOWN RELAY |
| ACS ENGINE CONTROL SWITCH | OPG OIL PRESSURE GAUGE | TDR TIME DELAY RELAY |
| BATT BATTERY | OPIR LOW OIL PRESSURE INDICATOR RELAY | TDX TIME DELAY AUXILIARY |
| CB CIRCUIT BREAKER | OPS OIL PRESSURE SWITCH | WT WATER TEMPERATURE GAUGE SENDER |
| CCM CYCLE CRANKING MODULE | OSIR OVERSPEED INDICATING RELAY | WTG WATER TEMPERATURE GAUGE |
| CTS CRANK TERMINATE SWITCH | OSS OVERSPEED SWITCH | WTIR HIGH WATER TEMPERATURE INDICATING RELAY |
| D DIODE | PIL PANEL ILLUMINATION LAMP | WTS WATER TEMPERATURE SWITCH |
| DSS DUAL SPEED SWITCH (INCLUDES CTS AND OSS) | PLS PANEL LAMP SWITCH | * INDICATES EQUIPMENT EXTERNAL TO CONTROL PANEL |
| I REMOTE START INITIATING CONTACT | PS PINION SOLENOID | ⊙ TERMINAL STRIP POINT (CONTROL PANEL) |
| MS MAGNETIC SWITCH (CRANK CIRCUIT) | RR RUN RELAY | ⊠ TERMINAL STRIP POINT (GENERATOR TERMINAL BOX) |
| MSG MAGNETIC SWITCH (GLOW PLUG CIRCUIT) | SS SHUT-OFF SOLENOID | |
| OCIR OVERCRANK INDICATING RELAY | SM STARTING MOTOR | |
| OCT OVERCRANK TIMER | | |

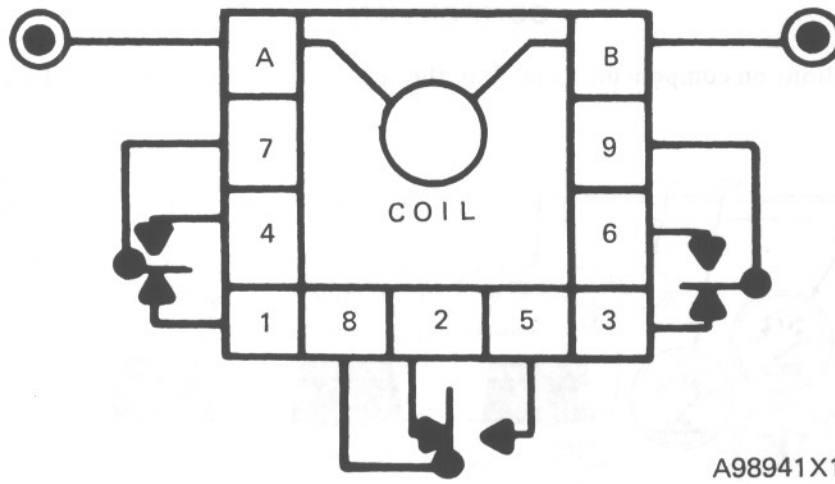

RELAY CONTACT SCHEMATIC

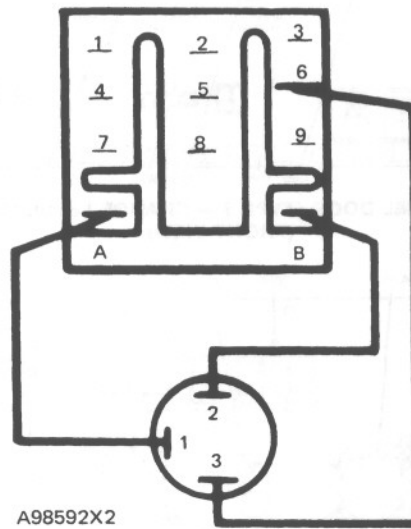

RELAY LAMP COMPONENT WIRING

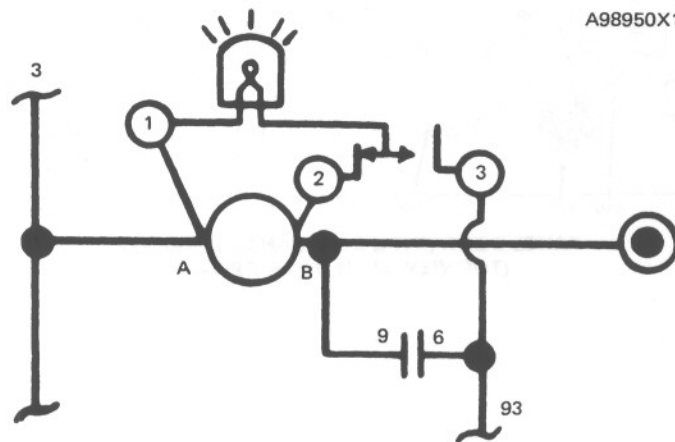

RELAY LAMP SCHEMATIC

COMPONENTS

NOTE: For specifications on components located on the engine, make reference to the ENGINE SERVICE MANUAL.

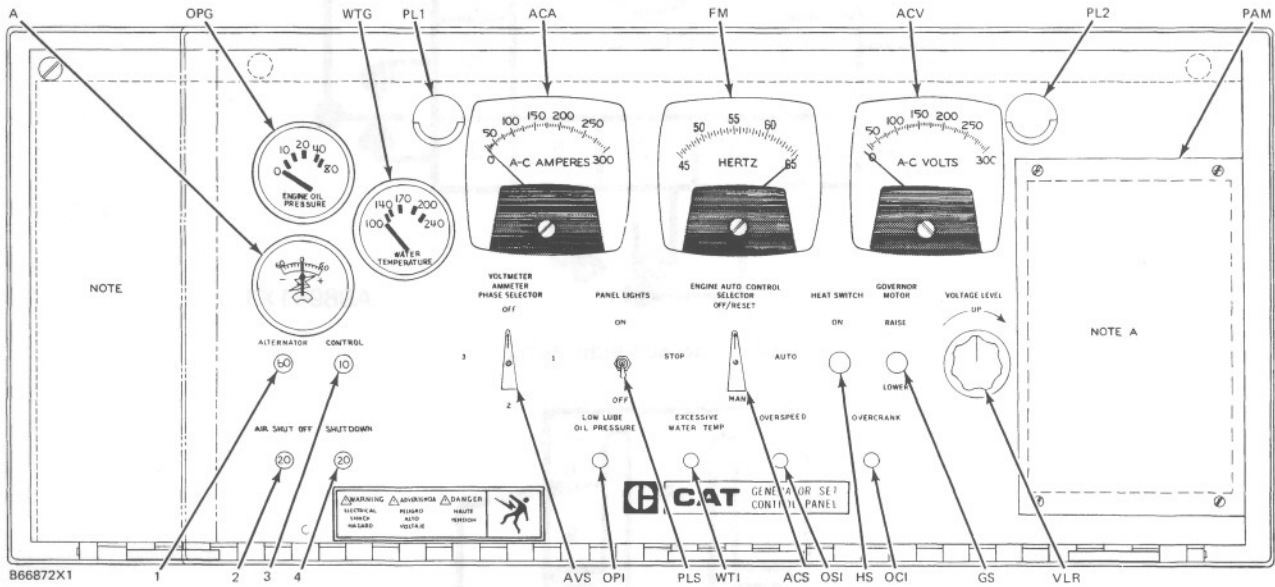

PANEL DOOR (TYPE 5 — CHANGE LEVEL 12)
(FRONT VIEW)

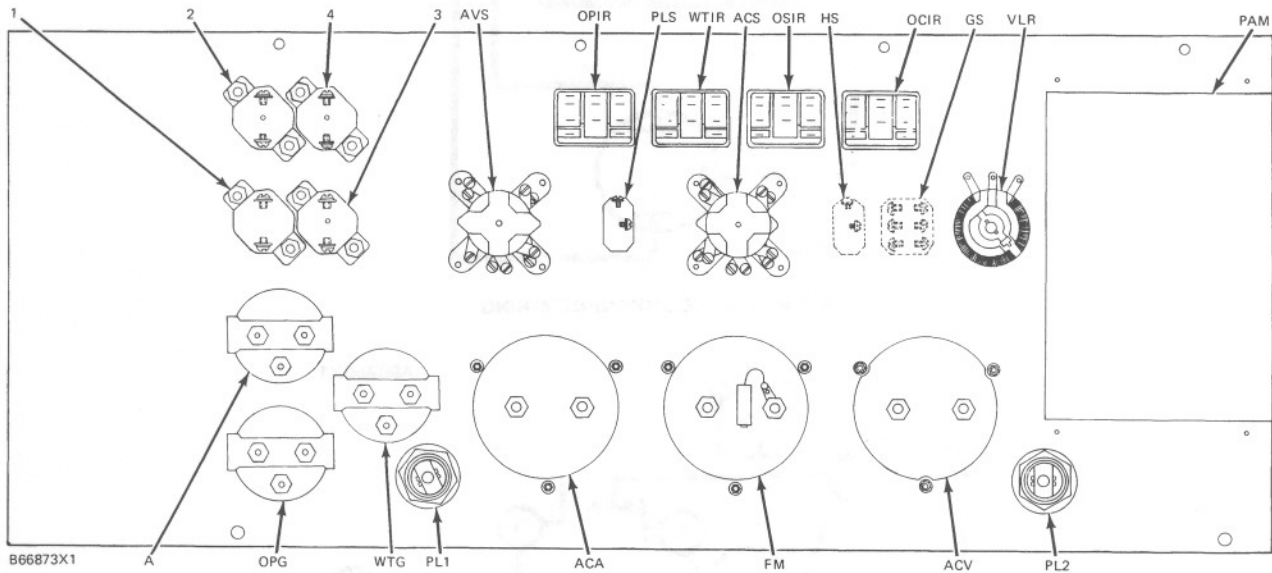

PANEL DOOR (TYPE 5 — CHANGE LEVEL 12)
(TOP VIEW WITH DOOR OPEN)

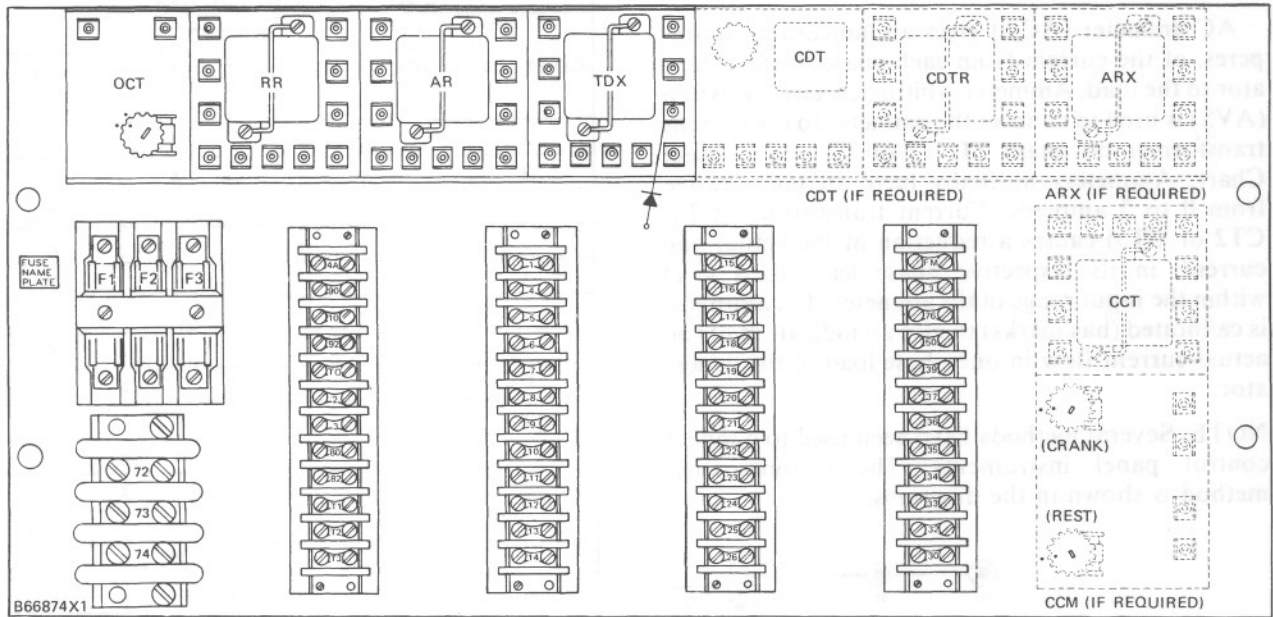

LOGIC PANEL (TYPE 5 — CHANGE LEVEL 12)
(FRONT VIEW INSIDE PANEL)

- | | | | |
|------|---------------------------------------|--------|-----------------------------------|
| 1. | 60 AMP CIRCUIT BREAKER (ALTERNATOR) | GS | GOVERNOR SWITCH |
| 2. | 20 AMP CIRCUIT BREAKER (AIR SHUT-OFF) | HS | HEAT SWITCH |
| 3. | 10 AMP CIRCUIT BREAKER (CONTROL) | OCI | OVERCRANK INDICATOR RELAY |
| 4. | 20 AMP CIRCUIT BREAKER (SHUTDOWN) | OCT | OVERCRANK TIMER |
| A | AMMETER | OPG | OIL PRESSURE GAUGE |
| ACA | ALTERNATING CURRENT AMMETER | OPI | OIL PRESSURE INDICATOR |
| ACS | ENGINE CONTROL SWITCH | OPIR | OIL PRESSURE INDICATOR RELAY |
| ACV | ALTERNATING CURRENT VOLTMETER | OSI | OVERSPEED INDICATOR |
| AVS | AMMETER/VOLTAGE SELECTOR SWITCH | OSIR | OVERSPEED INDICATOR RELAY |
| CDT | COOL DOWN TIMER | PAM | PREALARM MODULE |
| CDTR | COOL DOWN TIMER RELAY | PL1, 2 | PANEL LAMPS |
| CCM | CYCLE CRANKING MODULE | PLS | PANEL LAMP SWITCH |
| CCT | CYCLE CRANKING RELAY | WTG | WATER TEMPERATURE GAUGE |
| F1 | FUSE | WTI | WATER TEMPERATURE INDICATOR |
| F2 | FUSE | WTIR | WATER TEMPERATURE INDICATOR RELAY |
| F3 | FUSE | VLR | VOLTAGE LEVEL RHEOSTAT |
| FM | FREQUENCY METER | | |

ACA Alternating Current Ammeter

AC ammeter (ACA) gives an indication, in amperes, of the current from each phase of the generator to the load. Ammeter/voltmeter selector switch (AVS) is used to connect the ammeter to the current transformer on phase T1, T2 or T3; see Contact Chart. Ammeters normally have an input range from 0 to 5 amperes. Current transformer (CT1, CT2 or CT3) causes a reduction of the actual line current, in its respective phase lead, to a level within the input range of the ammeter. The ammeter is calibrated (has marks) to give an indication of the actual current flow in one phase load of the generator.

NOTE: Several methods have been used to connect control panel instruments. The recommended method is shown in the diagrams.

CONTACT	PHASES			
	OFF	1 (T1)	2 (T2)	3 (T3)
1		X	X	X
2		X		
3			X	
4				X
5		X	X	X
6		X		
7			X	
8				X
9	X	X	X	X
10	X	X	X	
11			X	X
12				X
13	X	X	X	
14	X	X	X	X
15		X	X	X
16	X	X	X	X
17	X	X	X	X

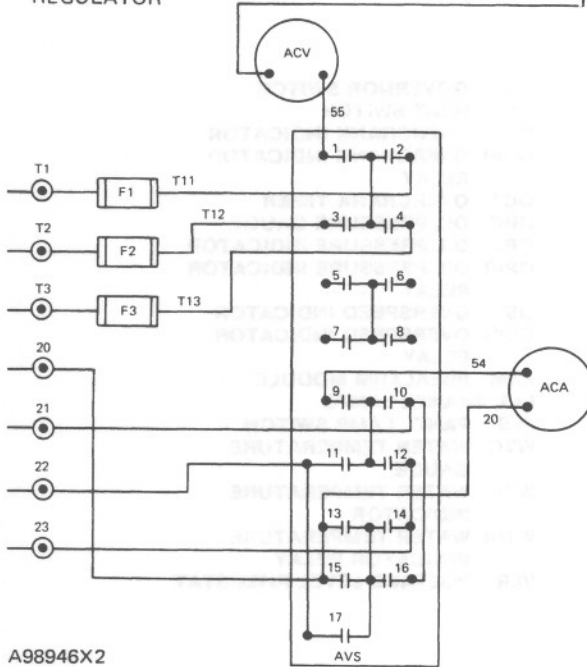
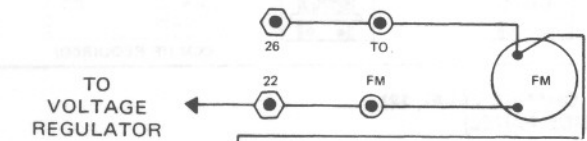

A98946X2

(600V Control Panel Only)

NOTE: X gives an indication of a closed contact, X on the line gives an indication of "make before break."

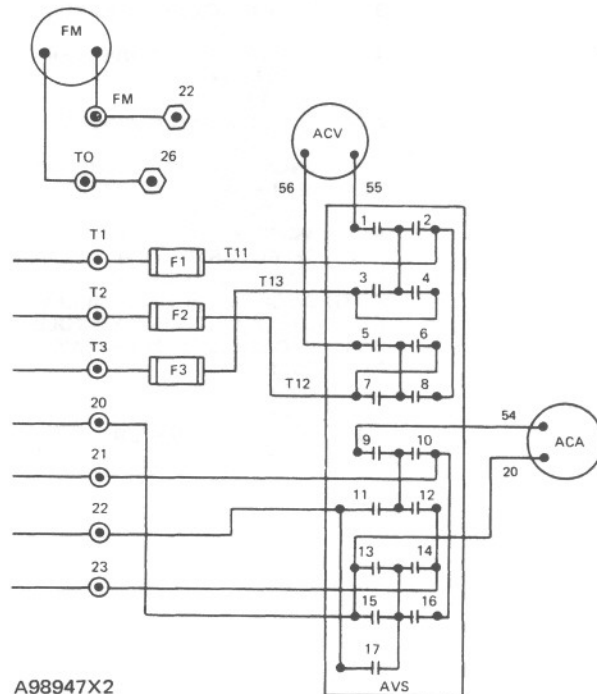

A98947X2

AMMETER/VOLTMETER SELECTOR SWITCH (AVS) WIRING DIAGRAMS

ACA Alternating current ammeter
 ACV Alternating current voltmeter
 F1,2,3 Fuses
 FM Frequency meter

⊙ Terminal point on TS2 in control panel
 ⊙ Terminal Point on TS3 part of voltage regulator

ACS Engine Control Switch

Engine control switch (ACS) controls the engine start and stop systems. To start the engine, move the switch to the MANUAL position. To stop the engine move the switch to the STOP or OFF/RESET position. For standby application (engine starts when remote initiating contact I closes), move the switch to the AUTO position. To start after engine shutdown caused by high water temperature, low oil pressure or overspeed, turn switch to STOP position and correct fault. Then move switch to OFF/RESET position. Engine can now be started in MANUAL or AUTO position. For more information on the operation of this switch, make reference to the AUTOMATIC START/STOP SYSTEM.

CONTACT CHART FOR ACS							
CONTACT	OFF-RESET	AUTO	MAN	STOP			
1		X	X	X			
2		X					
3			X				
4							X
5		X	X	X			X
6		X					
7			X				
8							X
9		X	X	X	X	X	X
10		X	X	X			
11			X	X	X		
12						X	X
13	X	X	X				
14	X	X	X	X	X	X	X
15		X	X	X	X	X	X
16	X	X	X	X	X	X	X
17	X	X	X	X	X	X	X

NOTE: X gives an indication of a closed contact, X on the line gives an indication of "make before break."

ACV Alternating Current Voltmeter

AC voltmeter (ACV) shows the potential differential (voltage) between phase T1-T2, T2-T3 or T3-T1 at position 1, 2 or 3 respectively. Make reference to the ALTERNATING CURRENT AMMETER.

DCA Direct Current Ammeter

DC Ammeter (DCA) is used when the ammeter is ordered. This ammeter shows the amount of DC current in amperes, that flows in the alternator circuit (if so equipped).

FM Frequency Meter

Frequency meter (FM) shows the hertz (cycles per second) of the electricity made when the generator set is in operation. There is a direct relation between the frequency of the electricity and the rpm of the generator set; see formula.

$$\text{frequency (hertz)} = \frac{\text{number of poles} \times \text{rpm}}{120}$$

GS Governor Switch

Governor switch (GS) is used when the engine is equipped with a remote control synchronizing motor for the governor. Engine speed is controlled with this switch.

HS Heat Switch

Heat switch (HS) is when the engine is equipped with glow plugs. This switch is used to operate the glow plugs for cold weather starting.

OPG Oil Pressure Gauge

Oil pressure gauge (OPG) shows the pressure, in psi, of engine lubrication oil. When pressure switch (PSW) is closed, oil pressure gauge (OPG) is connected across battery voltage. There is a relation between the current flow in this circuit and the engine oil pressure read on oil pressure gauge (OPG). Oil pressure sender (OP) controls the current flow by a change in resistance according to the change in engine oil pressure.

PAM Prealarm Module

Make reference to ATTACHMENTS.

PL1, 2 Panel Lamps

Light for the control panel is given by panel lamps (PL1 and PL2). These lamps are controlled by panel light switch (PLS).

VLR Voltage Level Rheostat

Voltage level rheostat (VLR) takes the place of voltage level rheostat (R2) on the generator regulator assembly. It is used to adjust the voltage output of the generator.

NOTE: Make reference to OPERATION OF GENERATOR; REGULATOR ADJUSTMENT. On generators equipped with a generator mounted control panel, the yellow wire from voltage level rheostat (R2) to terminal (7) on the regulator terminal strip is disconnected at terminal (7).

AUTOMATIC START/STOP SYSTEM

Introduction

The automatic start/stop system is normally used for standby operation. That is, without an operator. The generator set must start, pick up the load, operate the load, and stop after the load is removed. An automatic transfer switch controls the transfer of load to and from the generator set. When normal (commercial) power has a failure, initiating contactor (I), part of the automatic transfer switch, closes. This will begin the automatic start sequence. When the engine starts, the control panel instruments will show voltage and frequency. The automatic transfer switch will transfer the load to the generator set when voltage and frequency reach approximately rated value. When normal power returns, the automatic transfer switch will transfer the load back to normal power. Initiating contactor (I) will open. This will begin the automatic stop sequence. The generator set will also stop automatically if the engine has a failure.

The packaged generator set has shutdown sensors, shutdown indicators and shutdown circuit for the conditions that follow.

1. Low oil pressure
2. High water temperature
3. Overspeed
4. Overcrank

NOTE: For specifications on components located on the engine, make reference to the ENGINE SERVICE MANUAL.

Automatic Start

With engine control switch (ACS) in the AUTO position, contacts (10) and (9) are closed. When commercial (normal) power has a failure, remote start initiating contact (I) closes. This makes a complete circuit from battery (BATT) to energize run relay (RR) through normally closed contacts of the four engine fault relays (OPR), (WTRI), (OSRI), (OCR).

When run relay (RR) is energized, contact (RR2) opens and contact (RR1) closes. (RR2) open prevents current flow to shutoff solenoid (SS). (RR1) closed energizes the (MS) through a normally closed (AR2) contact. At the same time power is applied to the overcrank timer (OCT). A magnetic pickup relays engine rpm to the dual speed switch (DDS). The dual speed switch has a crank terminate (CTS) circuit and an overspeed (OSS) circuit.

When overcrank timer (OCT) is energized, a timer will start. After the engine cranks for approximately 30 seconds the timer will stop. (OCT) contacts will open. Make reference to ENGINE DOES NOT START.

When magnetic switch (MS) is energized, (MS) contacts close and pinion solenoid (PS) is energized. This causes (PS) contacts to close, starting motor (SM) will crank the engine.

Manual Start

The current flow for manual start is similar to automatic start except engine control switch (ACS) is turned to the MAN position. Contact (10) is open and contact (11) is closed. It is not necessary for remote start indicating contact (I) to close. Run relay (RR) and magnetic switch (MS) will energize the same as with Automatic Start.

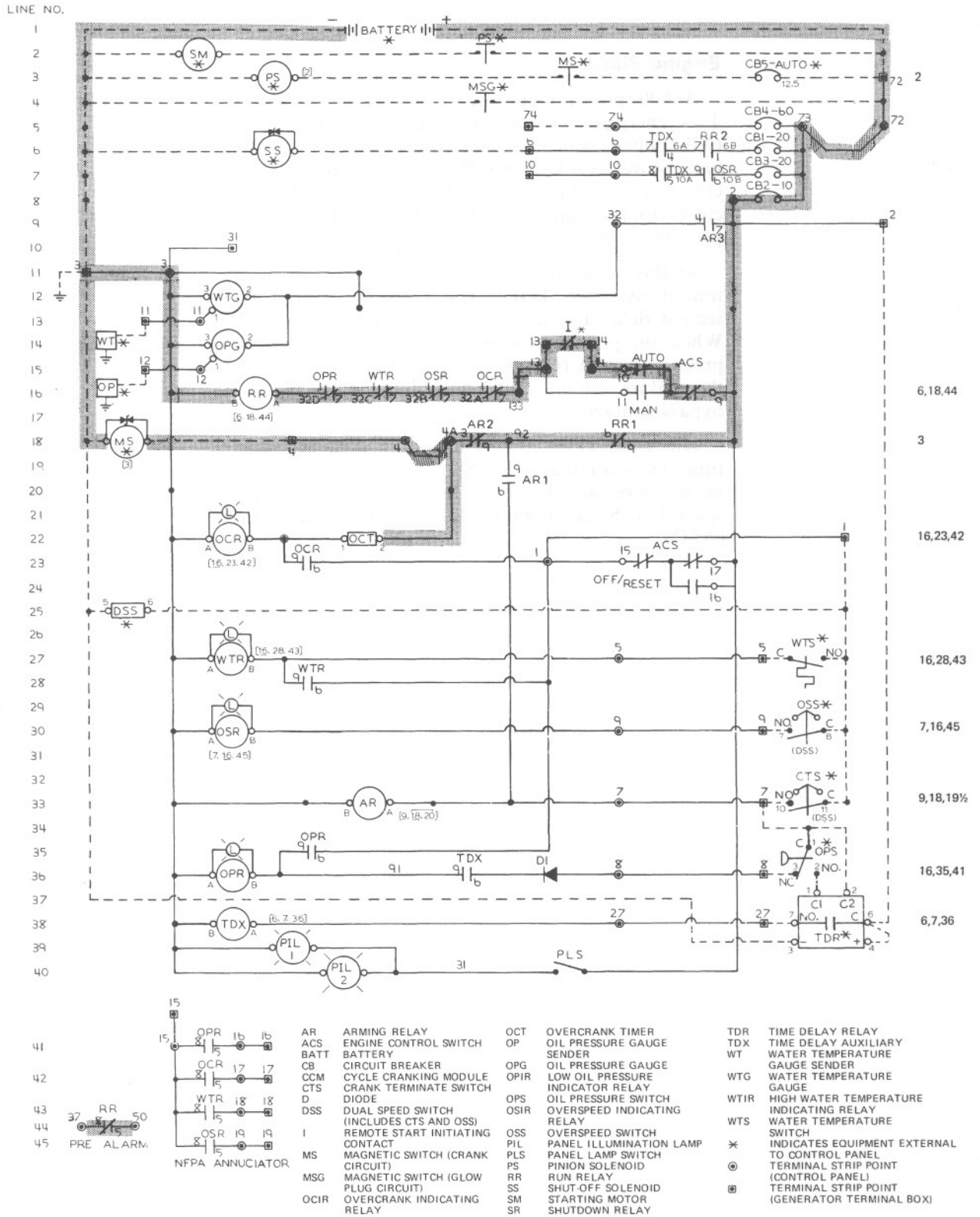

**CONTROL PANEL
AUTO POSITION (ENGINE CRANKS)**

B66875X1

Engine Starts

At 600 rpm, crank terminate switch (CTS) closes. This energizes the arming relay (AR). Contact (AR2) opens which disconnects the circuit to (MS) and the overcrank timer (OCT). The contact (AR1) closes to lock in the (AR) relay. Contact (AR3) closes to turn on the water temperature and oil pressure gauges.

At this same time, the (CTS) contact arms the time delay relay (TDR). The TDR has a fixed 9 second delay to allow for oil pressure build up. When oil pressure comes up, it actuates the oil pressure switch (OPS). The (OPS) contact clears the failure circuit and closes the (TDR) timer bypass contact.

When the TDR contact closes, it energizes the time delay auxiliary (TDX). The TDX arms the oil pressure failure circuit along with the shut-off solenoid (SS) and the optional air shut-off solenoid (ASO).

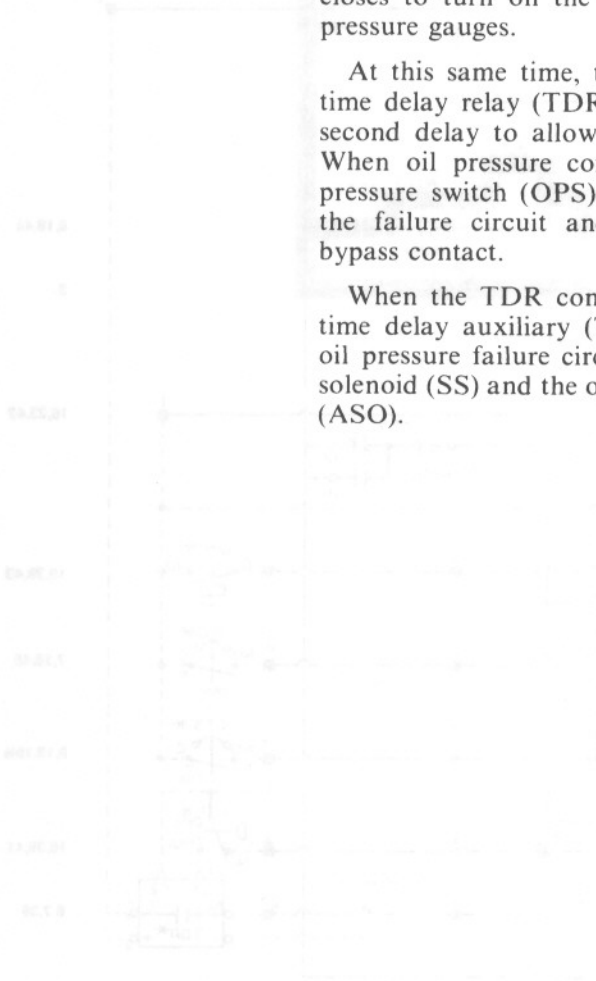

- 1. FUSE
- 2. STOP BUTTON
- 3. START BUTTON
- 4. CRANK TERMINATE SWITCH (CTS)
- 5. ARMING RELAY (AR)
- 6. TIME DELAY RELAY (TDR)
- 7. TIME DELAY AUXILIARY (TDX)
- 8. OIL PRESSURE SWITCH (OPS)
- 9. SHUT-OFF SOLENOID (SS)
- 10. OPTIONAL AIR SHUT-OFF SOLENOID (ASO)

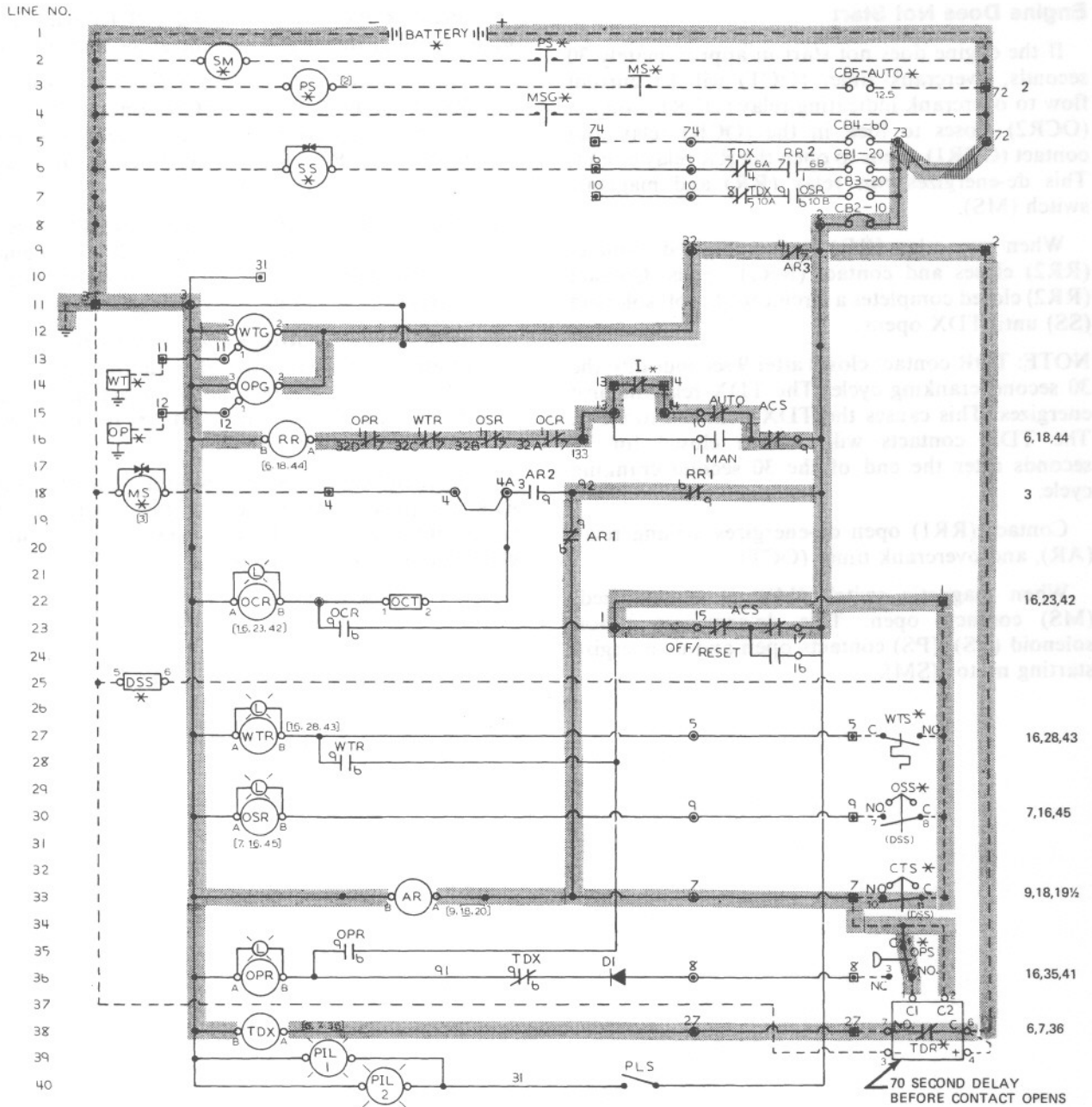

41	OPR 15	15	15	AR	ARMING RELAY	OCT	OVERCRANK TIMER	TDR	TIME DELAY RELAY
42	ACS 16	16	16	ACS	ENGINE CONTROL SWITCH	OP	OIL PRESSURE GAUGE SENDER	TDX	TIME DELAY AUXILIARY GAUGE SENDER
43	WTG 17	17	17	BATT	BATTERY	OPG	OIL PRESSURE GAUGE	WTG	WATER TEMPERATURE GAUGE SENDER
44	OPR 18	18	18	CB	CIRCUIT BREAKER	OPIR	LOW OIL PRESSURE INDICATOR RELAY	WTG	WATER TEMPERATURE GAUGE
45	OCR 19	19	19	CCM	CYCLE CRANKING MODULE	OPS	OIL PRESSURE SWITCH	WTIR	HIGH WATER TEMPERATURE INDICATING RELAY
	OSR 15	15	15	D	CRANK TERMINATE SWITCH	OSIR	OVERSPEED INDICATING RELAY	WTS	WATER TEMPERATURE SWITCH
	OPR 18	18	18	DSS	DUAL SPEED SWITCH (INCLUDES CTS AND OSS)	OSS	OVERSPEED SWITCH	*	INDICATES EQUIPMENT EXTERNAL TO CONTROL PANEL
	OSR 19	19	19	I	REMOTE START INITIATING CONTACT	PIL	PANEL ILLUMINATION LAMP	⊙	TERMINAL STRIP POINT (CONTROL PANEL)
	MSG 31	31	31	MS	MAGNETIC SWITCH (CRANK CIRCUIT)	PLS	PANEL LAMP SWITCH	⊠	TERMINAL STRIP POINT (GENERATOR TERMINAL BOX)
	MSG 31	31	31	MSG	MAGNETIC SWITCH (GLOW PLUG CIRCUIT)	PS	STARTING MOTOR SHUTDOWN RELAY		
	OCIR 15	15	15	OCIR	OVERCRANK INDICATING RELAY	SR	SHUTDOWN RELAY		

B66876X1

**CONTROL PANEL
AUTO POSITION (ENGINE STARTS)**

Engine Does Not Start

If the engine does not start in approximately 30 seconds, overcrank timer (OCT) will let current flow to overcrank indicating relay (OCR). Contact (OCR2) closes to lock in the (OCR) relay and contact (OCR1) opens to open the RR relay circuit. This de-energizes run relay (RR) and magnetic switch (MS).

When run relay (RR) is de-energized, contact (RR2) closes and contact (RR1) opens. Contact (RR2) closed completes a circuit to shutoff solenoid (SS) until TDX opens.

NOTE: TDR contact closes after 9 seconds into the 30 second cranking cycle. The TDX relay in turn energizes. This causes the TDX contacts to close. The TDX contacts will remain closed for 70 seconds after the end of the 30 second cranking cycle.

Contact (RR1) open de-energizes arming relay (AR), and overcrank timer (OCT).

When magnetic switch (MS) is de-energized, (MS) contacts open. This de-energizes pinion solenoid (PS). (PS) contacts open and de-energize starting motor (SM).

Overcrank indicating relaying (OCR) will give light. To start the engine, do the steps that follow:

1. Turn engine control switch (ACS) to OFF/RESET. This will open (ACS) contact (IS) and de-energize overcrank indicating relay (OCR). Contact OCR1 will close so that the run relay (RR) can be energized.
2. Turn the engine control switch to MANUAL or AUTO if I contact is closed. If the engine does not start in approximately 30 seconds, the overcrank indicating relay will give light.
3. Turn engine control switch (ACS) to STOP position. Observe fault lights and turn ACS to OFF/RESET. Correct the problem that caused the engine not to start. Make reference to TROUBLESHOOTING.

NOTE: If the engine can not be started or stopped with the panel controls, check the condition of circuit breaker (CB2). (There is no visual indication of its condition). Press to reset.

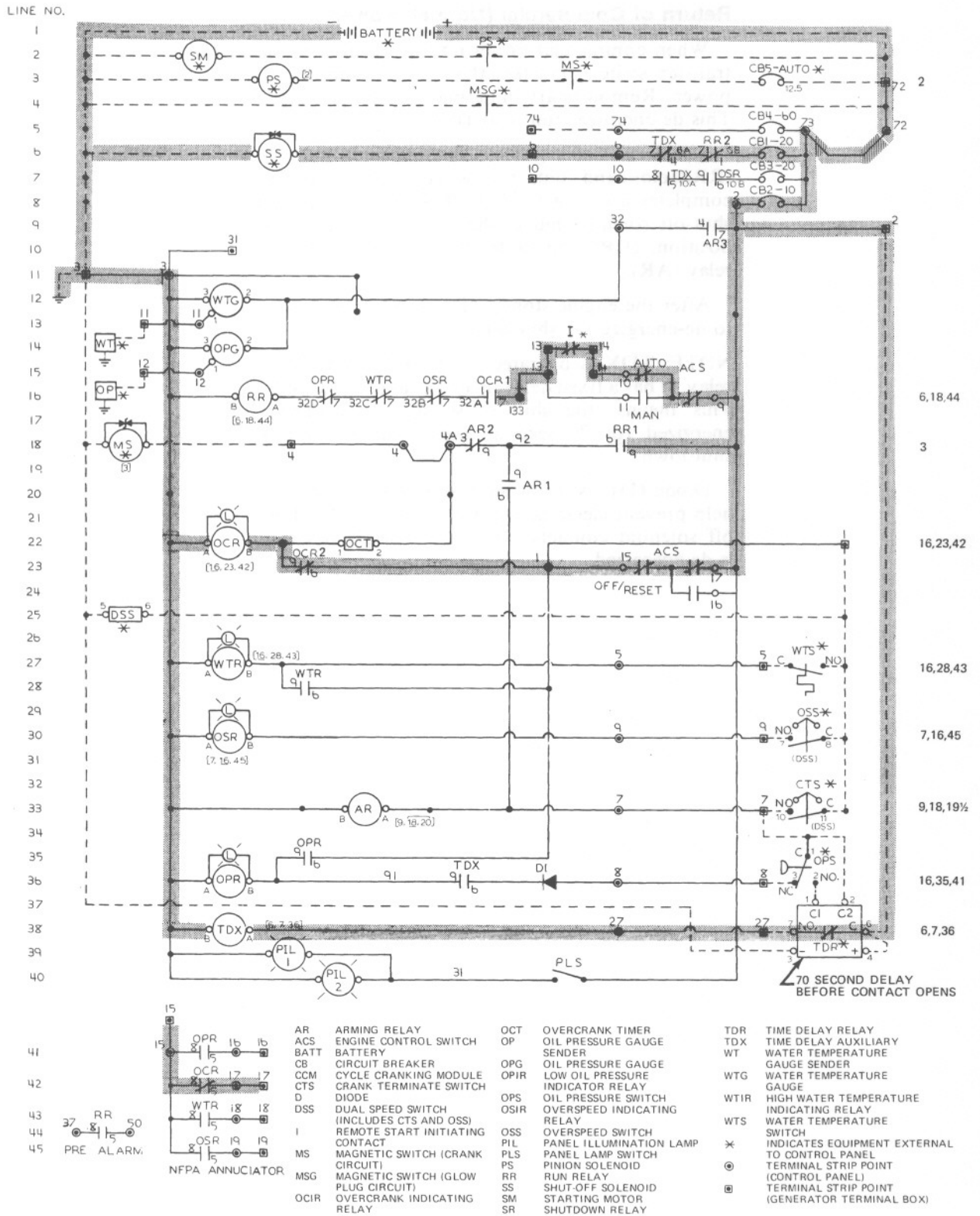

B66877X1

CONTROL PANEL
AUTOMATIC POSITION (ENGINE DOES NOT START)

Return of Commercial (Normal) Power

When commercial power returns, the automatic transfer switch transfers the load to commercial power. Remote start initiating contacts (I) open. This de-energizes run relay (RR).

When run relay (RR) is de-energized, contacts (RR2) close and contacts (RR1) open. (RR2) closed completes a circuit to shut-off solenoid (SS). The shut-off solenoid moves the rack to the fuel OFF position. (RR1) opens to de-energize the arming relay (AR).

After the engine stops, (TDX) contact will open to de-energize the shut-off solenoid.

NOTE: TDX is operated by the TDR time delay relay. It has a fixed delay on drop out of 70 seconds. This means, the shut-off solenoid will remain energized for 70 seconds each time the unit is shutdown.

Diode (D1) is in the shut-off solenoid circuit to help prevent electrical sparks (arcing), at the shut-off solenoid contacts, when the shut-off solenoid is de-energized.

