

[Previous Screen](#)

< Product: GENERATOR SET
Model: 3456 GENERATOR SET C4G
Configuration: 3456 Generator Set C4G00001-UP

Testing and Adjusting 3406E and 3456 Generator Set Engines

Media Number -REN2303-04

Publication Date -01/10/2004

Date Updated -07/10/2004

i02163244

Fuel System - Prime

SMCS - 1258-548

The Secondary Fuel Filter Has Been Replaced



WARNING

Fuel leaked or spilled onto hot surfaces or electrical components can cause a fire. To help prevent possible injury, turn the start switch off when changing fuel filters or water separator elements. Clean up fuel spills immediately.

NOTICE

Use a suitable container to catch any fuel that might spill. Clean up any spilled fuel immediately.

NOTICE

Do not allow dirt to enter the fuel system. Thoroughly clean the area around a fuel system component that will be disconnected. Fit a suitable cover over disconnected fuel system component.

Note: Refer to Operation and Maintenance Manual, "Fuel System Secondary Filter - Replace" for information on replacing the filter.

1. Turn the engine control switch (ECS) to the "OFF" position.

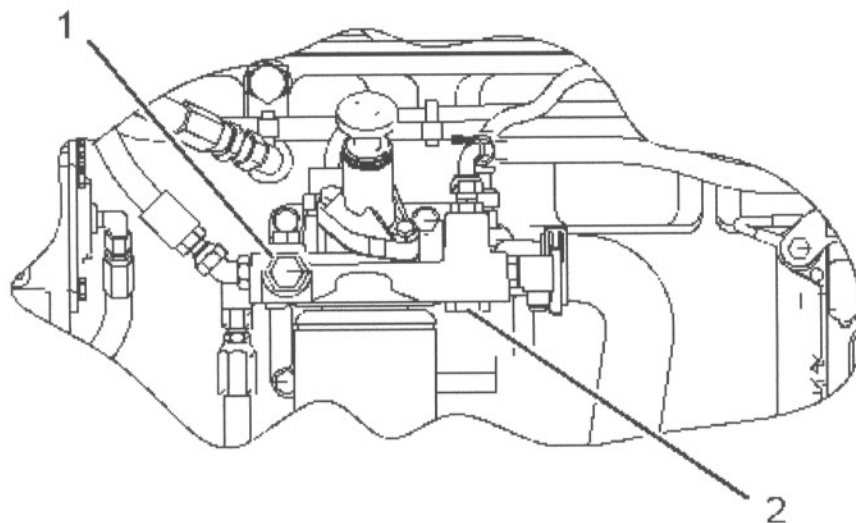

Illustration 1
Hand priming pump

g01096972

- (1) Air purge screw
- (2) Fuel pressure regulating valve

2. Open air purge screw (1) for the fuel filter by three full turns. Do not remove the air purge screw.

NOTICE

Do not crank the engine continuously for more than 30 seconds. Allow the starting motor to cool for two minutes before cranking the engine again.

3. Start the engine. The engine should start and the engine should run smoothly. If the engine does not start after 30 seconds, allow the starter motor to cool for two minutes before attempting to start the engine again.

Note: You may use the hand priming pump for the fuel filter (if equipped) instead of starting the engine and running the engine.

4. While the engine is running, observe air purge screw (1). When a small drop of fuel appears at the threads of the air purge screw, close and tighten air purge screw (1).

Note: There may be a noticeable change in the sound of the running engine when the air purge screw is tightened. The change in the sound of the engine is normal.

Note: Failure to tighten all fittings could result in serious fuel leaks.

5. Clean any residual fuel from the engine components.

The Engine Has Been Run Out of Fuel

NOTICE

Use a suitable container to catch any fuel that might spill. Clean up any spilled fuel immediately.

NOTICE

Do not allow dirt to enter the fuel system. Thoroughly clean the area around a fuel system component that will be disconnected. Fit a suitable cover over disconnected fuel system component.

1. Turn the ECS to the "OFF" position.
2. Fill the fuel tank(s) with clean diesel fuel.

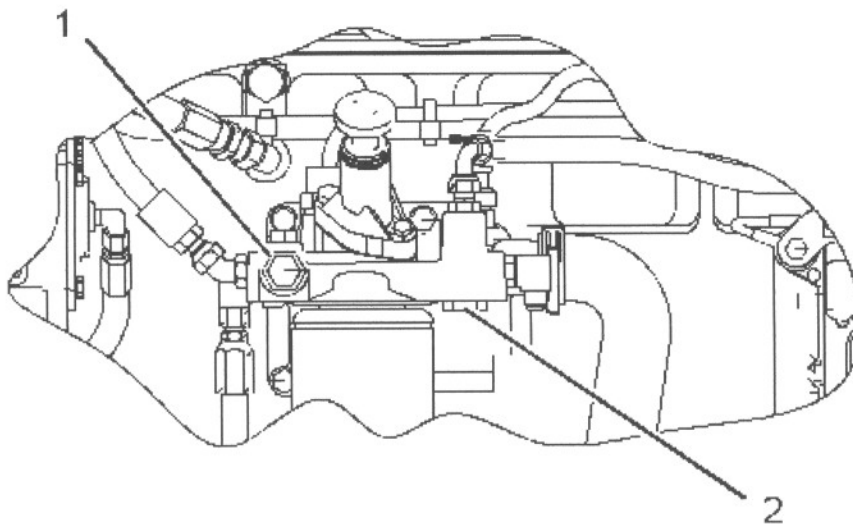

Illustration 2

g01096972

Hand priming pump

- (1) Air purge screw
- (2) Fuel pressure regulating valve
3. Open fuel pressure regulating valve (2) by two and a half turns. The regulating valve is located in the integral fuel filter base.

Note: Do not remove the regulating valve completely. Open the valve enough to allow the air that is trapped in the cylinder head to be purged from the fuel system.

NOTICE

Do not crank the engine continuously for more than 30 seconds. Allow the starting motor to cool for two minutes before cranking the engine again.

4. Crank the engine for 30 seconds. Use a suitable container to catch the fuel while you crank the engine. Allow the starter motor to cool for two minutes.

Note: You may use the hand priming pump for the fuel filter (if equipped) instead of cranking the engine.

5. Crank the engine for 30 seconds. Allow the starter motor to cool for two minutes.
6. Close and tighten fuel pressure regulating valve (2) .
7. Crank the engine for 30 seconds. Allow the starter motor to cool for two minutes.
8. Repeat Step 7 until the engine starts and the engine runs.

Note: Failure to tighten all fittings could result in serious fuel leaks.

9. Clean any residual fuel from the engine components.

The Engine Has Been Rebuilt

NOTICE

Use a suitable container to catch any fuel that might spill. Clean up any spilled fuel immediately.

NOTICE

Do not allow dirt to enter the fuel system. Thoroughly clean the area around a fuel system component that will be disconnected. Fit a

suitable cover over disconnected fuel system component.

1. Turn the ECS to the "OFF" position.
2. Fill the fuel tank (s) with clean diesel fuel.

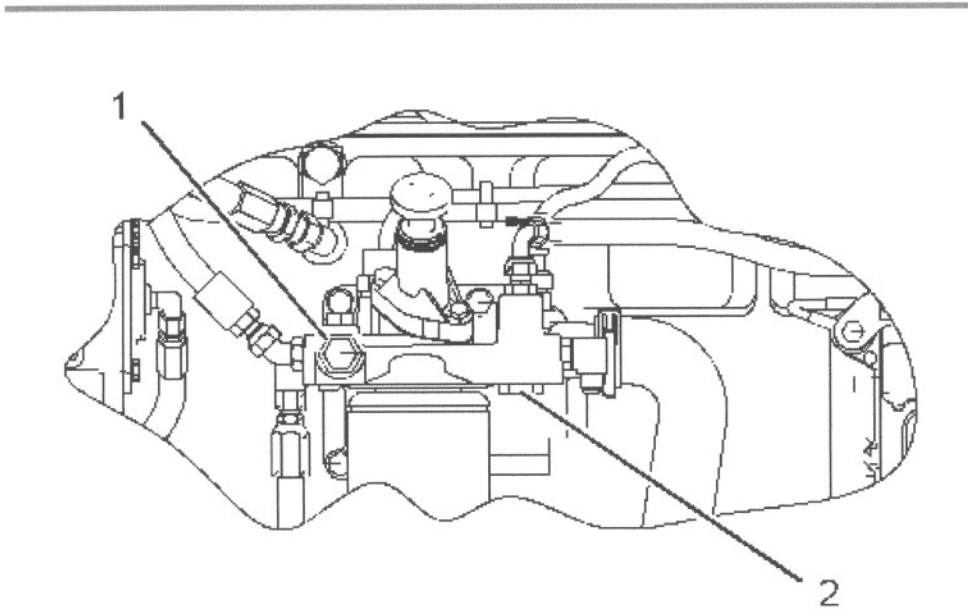

Illustration 3
Hand priming pump

g01096972

- (1) Air purge screw
 - (2) Fuel pressure regulating valve
3. Open the air purge screw (1) for the fuel filter by three full turns. Do not remove the air purge screw.
 4. Open fuel pressure regulating valve (2) by two and a half turns. The regulating valve is located in the integral fuel filter base.

Note: Do not remove the regulating valve completely. Open the valve enough to allow the air that is trapped in the cylinder head to be purged from the fuel system.

NOTICE

Do not crank the engine continuously for more than 30 seconds. Allow the starting motor to cool for two minutes before cranking the engine again.

-
5. Crank the engine for 30 seconds. Use a suitable container to catch the fuel while you crank the engine. Allow the starter motor to cool for two minutes.

Note: You may use the hand priming pump for the fuel filter (if equipped) instead of cranking the engine.

6. Crank the engine for 30 seconds. Allow the starter motor to cool for two minutes.
7. Close and tighten air purge screw (1) .
8. Crank the engine for 30 seconds. Allow the starter motor to cool for two minutes.
9. Close and tighten fuel pressure regulating valve (2) .

Note: Failure to tighten all fittings could result in serious fuel leaks.

10. Crank the engine for 30 seconds. Allow the starter motor to cool for two minutes.
11. Repeat Step 10 until the engine starts and runs.
12. Clean any residual fuel from the engine components.