

[Previous Screen](#)

< Product: NO EQUIPMENT SELECTED  
 Model: NO EQUIPMENT SELECTED  
 Configuration: NO EQUIPMENT SELECTED

## Specifications

### Caterpillar Digital Voltage Regulator (CDVR)

Media Number -RENR7941-00

Publication Date -12/01/2003

Date Updated -12/19/2003

i01915719

## Electrical

SMCS - 4467

Table 1

Specifications	
Regulation	0.25% from no load to full load.
Regulator temperature drift	Less than $\pm 1\%$ for any 40 °C (72 °F) change over the ambient operating temperature range.
Configurable Volts/Hz characteristic	Two slope ranges adjustable from 1 to 10 V/Hz. See the Regulation Characteristic Illustration.
Regulator response time	Maximum of 10 milliseconds.
Regulator sensing	True RMS 3-phase sensing is standard. Single phase sensing is available. Variable sense range: 90 to 600 volts.
Regulator stability	The regulator responds to the fundamental component of the sensed voltage and remains stable for total harmonic distortion of the generator output voltage waveform, up to 20%.
Telephone influence factor (TIF)	Less than 50. Complies with MIL STD 461C Part 9 and VDE 0875 level N.
Fine voltage adjust range	$\pm 10\%$ of regulator sensing voltage.
Regulator voltage gain (Line loss compensation)	Adjustable from 0 to 10%.
Fault detection and	Diagnostics identify operation outside of programmed limits. Specific fault

identification	information is available even after the unit has been powered down. CANBUS only	
Harmonic tolerance	The digital voltage regulator maintains precise control of the generator output with up to 20% harmonic distortion in the generator output voltage.	
Reactive droop adjustment	Adjustable from 0 to 10%.	
Overexcitation protection	Shuts off generator output when excitation current exceeds normal operating currents for 10 seconds or instantaneous shutoff if output current exceeds approximately 28 Amperes.	
Ambient operating temperature	-40 °C (-40 °F) to +70 °C (+ 158 °F).	
Storage temperature range	-40 °C (-40 °F) to +85 °C (+ 185 °F).	
Power dissipation	5 watts at idle, 55 watts at rated output.	
Shock	Withstands up to 20 g's in three mutually perpendicular planes.	
Vibration	Withstands 4.5 g's at frequencies between 18 and 2000 Hz in three mutually perpendicular planes.	
Salt fog	5% salt spray for 48 hours at 38 °C (100.4 °F) at 115% of the nominal operating voltage	
Weight	1.47 kg (3.24 lb).	
Electromagnetic compatibility	Meets 89/336/EEC Electromagnetic Compatibility Directive.	
Power supply	24 ± 6 volt DC power supply required (0.5 amp).	
Conformity	UL	UL Recognized per Standard 508, UL File No. E97035
	CSA	Certified per Standard CAN/CSA-C22.2 No. 14-95, CSA Dile No. LR 23131
	CE	Conforms to the following standards: Radiated Emissions EN50081-2, Radiated Immunity (electric field) EN61000-4-3 (10 V/m), Radiated Immunity (conducted) EN61000-4-6 (10 VRMS), Conducted Emissions EN50081-2 (EN55011, Class A), ESD Immunity EN50082-2 (4 KV contact, 8 KV air), EFT Immunity EN50082-2 (2 KV coupling clamp), Magnetic Immunity EN50082-2 (30ARMS, 50 Hz), Safety EN61010-1

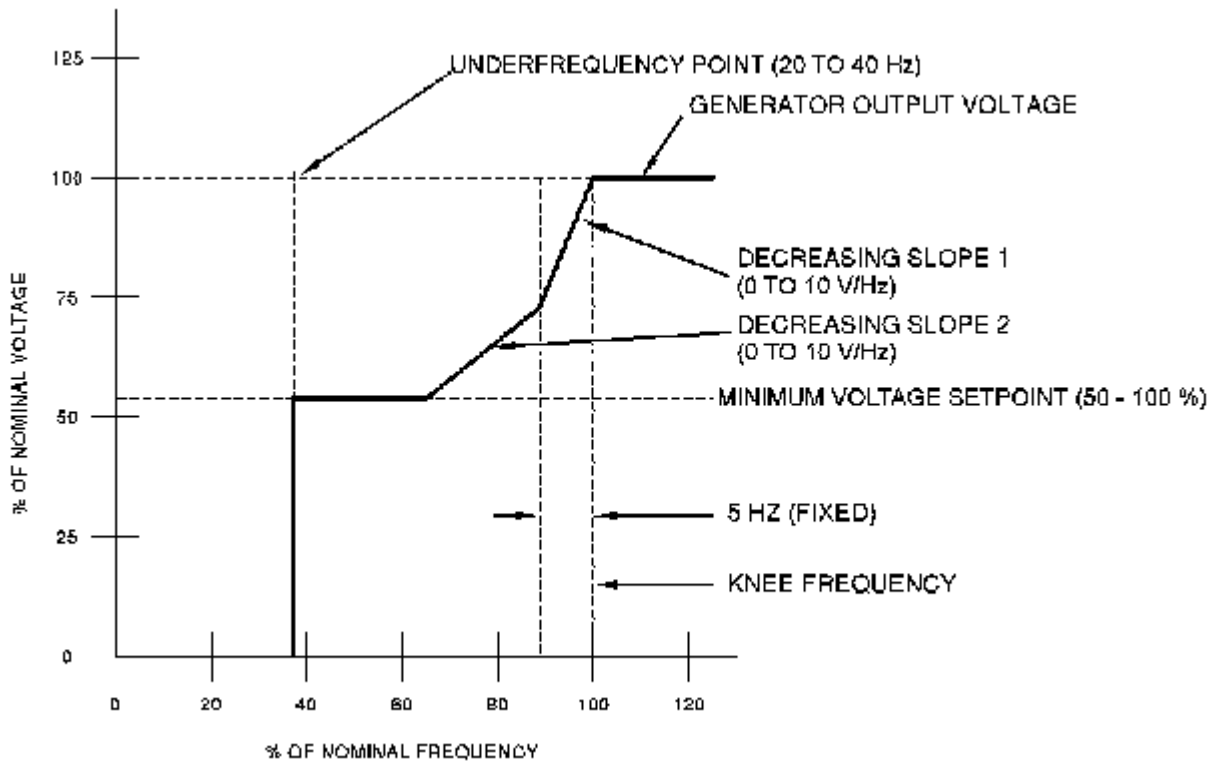

Illustration 1  
Regulation Characteristic

g0104

Table 2

Summary of Operating Parameters			
Parameter	Specifications		
Voltage Regulation Rating	120 to 15000 Volts		
Generator Type	PM SE AREP		
Power Input	Voltage	Frequency	Burden (Continuous)
	80 to 264 Volts (3Ø) 100 to 280 Volts (1Ø)	50 to 400 Hz	1150 VA or 1900 VA
	Maximum Continuous		Maximum Forcing (10 Seconds)

<b>Output Rating</b>	<b>Voltage</b>	<b>Current</b>	<b>Voltage</b>	<b>Current</b>
	63 or 125 Volts	12 or 10 Amperes	125 or 250 Volts	25 or 20 Amperes
<b>Sensing</b>	<b>Voltage</b>		<b>Maximum VA Burden per Ø</b>	
	90 to 600 Volts		1 VA	
<b>Reactive Droop</b>	<b>Maximum Current</b>		<b>Maximum VA Burden</b>	
	5 Amperes		1 VA	
<b>Exciter Field Resistance</b>	<b>Minimum Resistance</b>		<b>Maximum Resistance</b>	
	3 Ohms		39 Ohms	



[Previous Screen](#)

< Product: NO EQUIPMENT SELECTED  
Model: NO EQUIPMENT SELECTED  
Configuration: NO EQUIPMENT SELECTED

## Specifications

### Caterpillar Digital Voltage Regulator (CDVR)

Media Number -REN7941-00

Publication Date -12/01/2003

Date Updated -12/19/2003

i01915854

## Dimensions

SMCS - 4467

---

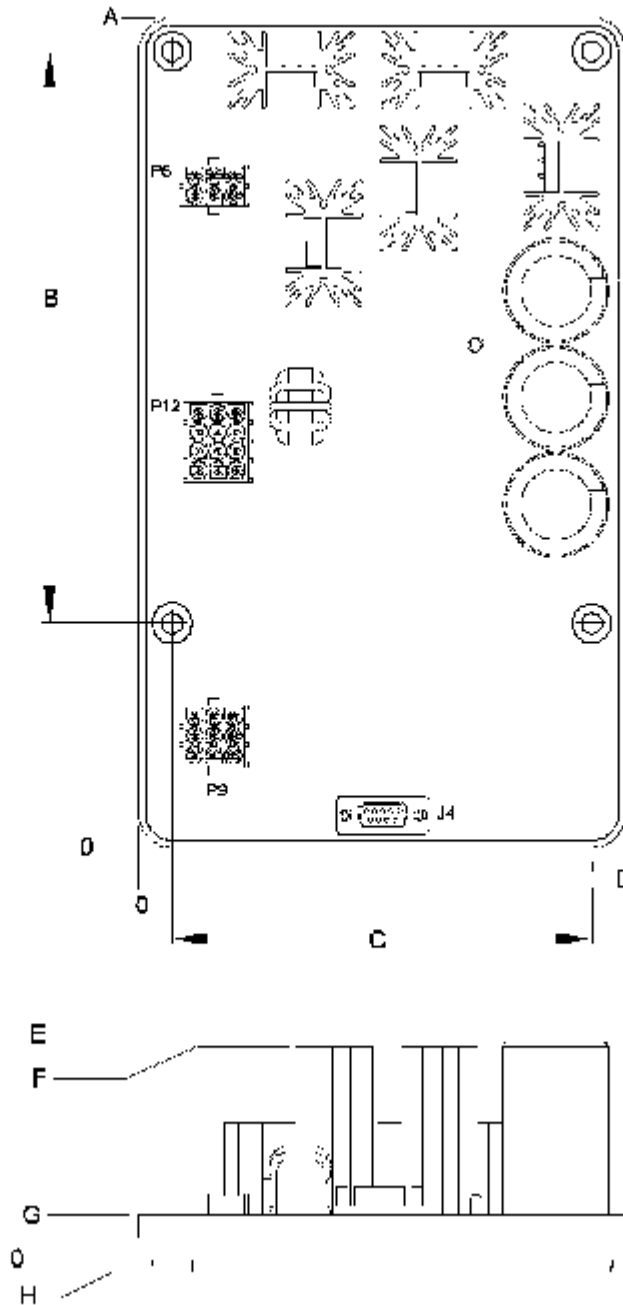

Illustration 1

g0102

## Dimensions of the Digital Voltage Regulator

(A) 276.4 mm (10.88 inch)

(B) 190.5 mm (7.50 inch)

(C) 139.7 mm (5.50 inch)

(D) 162.1 mm (6.38 inch)

(E) 72.9 mm (2.87 inch)

(F) 71.4 mm (2.81 inch)

(G) 15.0 mm (0.59 inch)

(H) 4.06 mm (0.16 inch)

---

Copyright 1993 - 2005 Caterpillar Inc.  
All Rights Reserved.  
Private Network For SIS Licensees.

Mon Feb 14 07:55:10 EST 2005

[Previous Screen](#)

< Product: NO EQUIPMENT SELECTED  
Model: NO EQUIPMENT SELECTED  
Configuration: NO EQUIPMENT SELECTED

## Systems Operation

### Caterpillar Digital Voltage Regulator (CDVR)

Media Number -RENR7941-00

Publication Date -12/01/2003

Date Updated -12/19/2003

i01917398

## General Information

SMCS - 4467

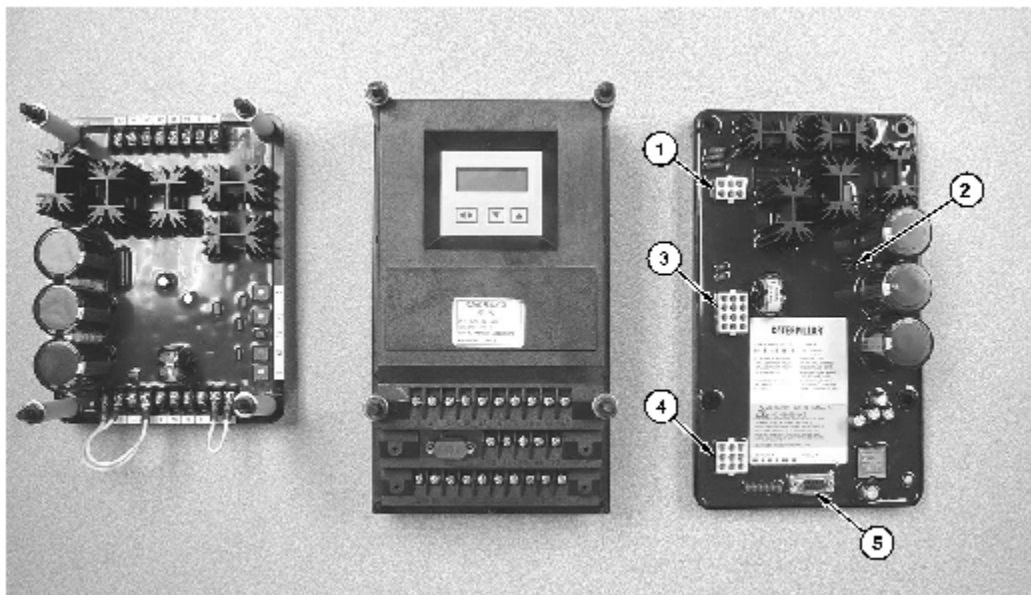

Illustration 1

g01040883

- (1) "P6" Connector
- (2) LED Indicator
- (3) "P12" Connector
- (4) "P9" Connector
- (5) "J4" Connector

The Caterpillar Digital Voltage Regulator is a microprocessor based voltage regulator. The main purpose of a digital voltage regulator is to regulate the output voltage of a generator that is used with an engine generator set. Control power for the Digital Voltage Regulator is supplied from an external 24 DCV source. The power stage of the Digital Voltage Regulator can be supplied from a multi-pole, high frequency, permanent magnet generator (PMG), from the generator output (shunt excitation), or from auxiliary windings that are included on some generators. Connections to the Digital Voltage Regulator are made through three multi-pin, plug type connectors. The communication between the Digital Voltage Regulator and a service tool is accomplished using a CANBUS protocol.

The Digital Voltage Regulator has three multiple-pin, plug-type connectors. These connectors are labeled "P6", "P9", and "P12". See illustration 1.

Connector "P6" is a six-pin header that mates with a six-pin connector. Connector "P9" is a nine-pin header that mates with a nine-pin connector. Connector "P12" is a twelve-pin header that mates with a twelve-pin connector.

The regulator has a nine-pin D-sub connector that is labeled "J4". This connector is used for interface with IBM-compatible personal computers.

**Note:** The Caterpillar Digital Voltage Regulator should be hard-wired to earth ground with at least a 16 AWG copper wire that is attached to the ground terminal "P6-6".

**Note:** When the unit is configured in a system with other devices, a separate lead should be used to ground the bus from each device.

**Note:** When the digital voltage regulator is installed remotely from the generator, special care should be given during installation to ensure proper engineering procedures are followed to prevent electromagnetic noise from reducing the performance of the regulator or other system components.

**Note:** When mounting the regulator remotely, the sensing wires, PMG wires, and exciter field wires should each be routed in their own separate tray or conduit. The optional customer wiring should be separated from all other signals in a control wiring conduit. The voltage sensing wires should be twisted together. Exciter field wires should also be twisted together.

## Connectors

### Connector "P6"

---

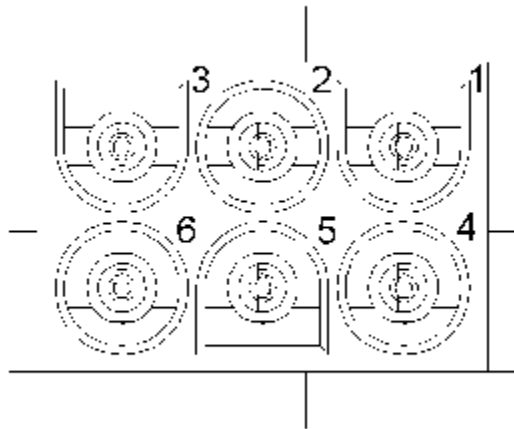

Illustration 2  
Pinout for the "P6" Connector

g01013614

Table 1

<b>P6 Terminal Functions</b>	
<b>Terminal</b>	<b>Function</b>
P6-1	Power Input
P6-2	Power Input
P6-3	Power Input
P6-4	F-
P6-5	F+
P6-6	Chassis Ground

## Connector "P9"

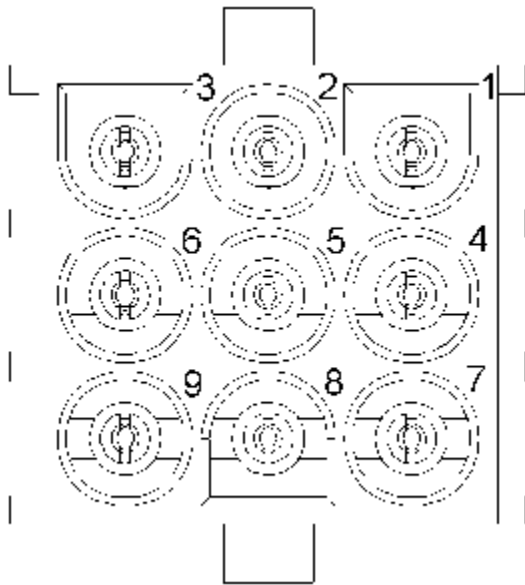

Illustration 3  
Pinout for the "P9" Connector

g01013761

Table 2

<b>P9 Terminal Functions</b>	
<b>Terminal</b>	<b>Function</b>
P9-1	CANbus - High
P9-2	CANbus - Low
P9-3	CANbus - Drain (Shield)
P9-4	Contact Sense - Lower
P9-5	Contact Sense - Raise
P9-6	Contact Sense - Common
P9-7	Contact Sense - Excitation Disable
P9-8	Contact Sense - Fault Reset
P9-9	Contact Sense - Var/PF Enable

## Connector "P12"

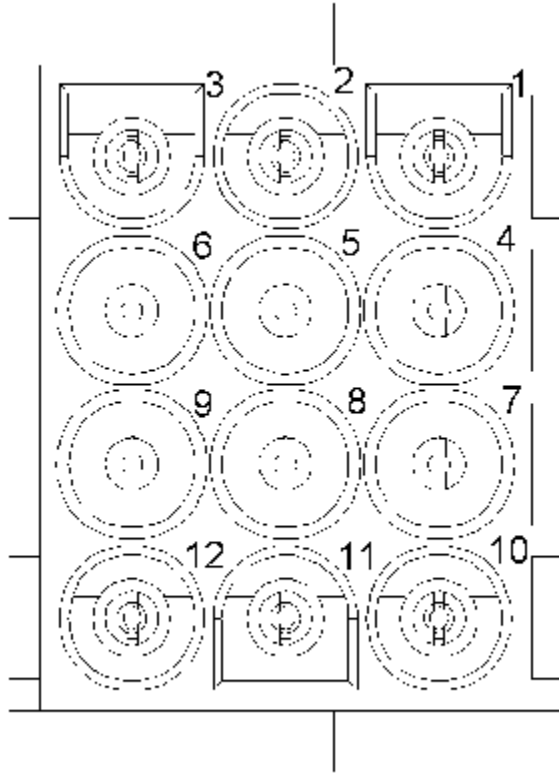

Illustration 4  
Pinout for the "P12" Connector

g01013628

Table 3

<b>P12 Terminal Functions</b>	
<b>Terminal</b>	<b>Function</b>
P12-1	B-phase generator current sensing (CT1)
P12-2	B-phase generator current sensing (CT2)
P12-3	±10 DCV Input (B), -
P12-4	Alarm Output Driver
P12-5	Fault Shutdown Driver
P12-6	±10 DCV Input (A), +
P12-7	18 to 30 V Control Power Input (B-)
P12-8	18 to 30 V Control Power Input (B+)

P12-9	Driver Supply (50)
P12-10	Generator Voltage Sensing - C
P12-11	Generator Voltage Sensing - B
P12-12	Generator Voltage Sensing - A

The Caterpillar Digital Voltage Regulator has the following features:

- Three control modes:
  1. Automatic voltage regulation (AVR)
  2. Power factor (PF) regulation
  3. Reactive power (VAR) regulation
- Programmable stability settings
- Soft start control with an adjustable time setting in AVR mode
- Dual slope voltage versus frequency (V/Hz) characteristic
- Three-phase or single-phase voltage sensing
- Single-phase current sensing
- Field current and field voltage sensing
- Ten protection functions

[Previous Screen](#)

< Product: NO EQUIPMENT SELECTED  
Model: NO EQUIPMENT SELECTED  
Configuration: NO EQUIPMENT SELECTED

## Systems Operation

### Caterpillar Digital Voltage Regulator (CDVR)

Media Number -RENR7941-00

Publication Date -12/01/2003

Date Updated -12/19/2003

i01932679

## Startup Profile Function

SMCS - 4467

The parameters that are related to the startup profile function are listed below.

- Generator Rated Voltage
- Knee Frequency
- Underfrequency Point

The digital voltage regulator will begin to build voltage following a volts per hertz profile after the configurable underfrequency point has been reached. When the speed reaches the knee frequency point, the loading/stopping profile takes effect. The startup profile function will not be initiated again unless the frequency drops below the underfrequency point. The underfrequency point is defaulted to 25 Hz, with a range of 20 to 40 Hz. This is the same underfrequency setpoint used by the loading/stopping setpoint. The knee frequency point is the point at which the digital voltage regulator will regulate to the voltage specified by the generator output voltage parameter.

[Previous Screen](#)

< Product: NO EQUIPMENT SELECTED  
 Model: NO EQUIPMENT SELECTED  
 Configuration: NO EQUIPMENT SELECTED

## Systems Operation

### Caterpillar Digital Voltage Regulator (CDVR)

Media Number -RENR7941-00

Publication Date -12/01/2003

Date Updated -12/19/2003

i01933190

## Loading and Stopping Profile

SMCS - 4467

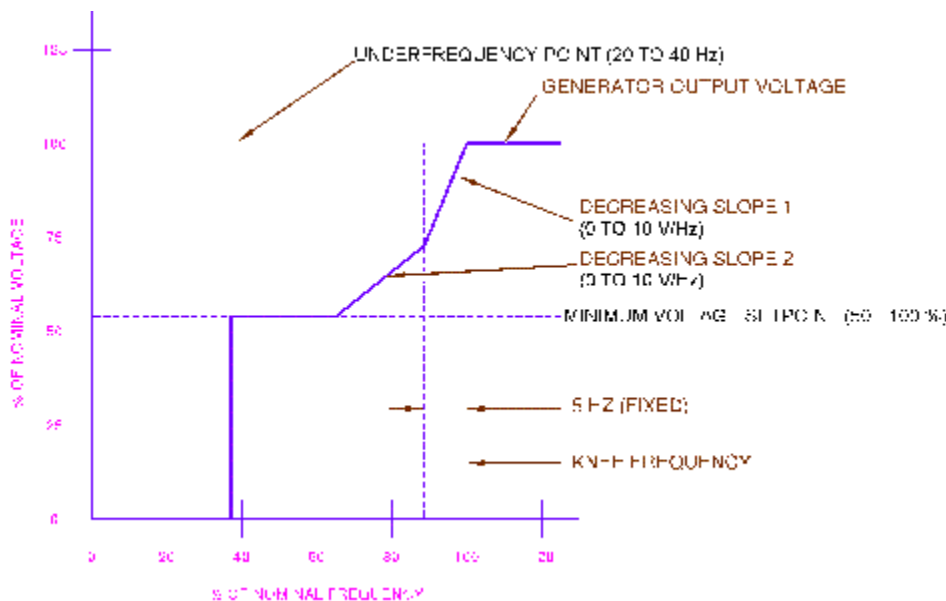

Illustration 1

g01012488

The parameters that are related to the loading and stopping profile are listed below.

- Generator Output Voltage
- Knee Frequency
- Decreasing V/Hz Slope 1
- Decreasing V/Hz Slope 2

- Minimum Voltage
- Underfrequency Point

Voltage regulators are generally of the volts per hertz type or the constant voltage type. The digital voltage regulator can perform as a constant voltage regulator or a volts per hertz type regulator depending on user configuration. Volts per hertz type regulators are commonly used with reciprocating internal combustion engine driven generator sets because they provide an automatic means for the engine to recover from a large block load. In the digital voltage regulator, the block load recovery performance is configurable so that it may be field optimized for each specific application.

When the generator is running and if a large load is applied, the frequency and voltage will drop. The loading/stopping function minimizes the amount of time that it takes the engine and generator to recover and increases the ability to pick up large loads.

As a large load is applied, the engine speed will begin to drop (frequency decreases). As the frequency decreases below the knee frequency, the voltage reference will decrease on a Volts/Hz slope according to the decreasing slope 1 value. If the frequency decrease continues beyond the knee frequency minus 5 Hz, then the voltage reference will decrease on a Volts/Hz slope according to the decreasing slope 2 value until the minimum voltage level is reached. The digital voltage regulator will try to regulate the generator output voltage at the minimum voltage, unless the underfrequency point is reached where the generator output voltage will decrease to a minimum value.

As the engine recovers from the load increase, the voltage will increase in the reverse order as it decreased, unless the frequency dropped below the underfrequency point. If the frequency dropped below the underfrequency point, the startup profile will be used for the recovery.

In some applications it is desirable to maintain a constant voltage at the possible sacrifice of a larger frequency dip during load transients. The digital voltage regulator can accommodate these applications if the knee frequency is configured for a lower value than normal. The actual value will depend on the specific application. When used in this application, the load transients must be kept small in order to allow the engine to recover without dropping below the knee frequency.

When a large block load is switched on to the system, the engine speed temporarily decreases as the engine produces the additional power requirement by burning more fuel. If the regulator is set to act as a volts per hertz type, it will reduce the output voltage according to the slope of the V/Hz curve. The reduction in voltage reduces the power requirement of the load, thus allowing the engine to recover faster for a given block load. If the regulator is set to act as a constant voltage type, the regulator will not reduce the output voltage for a change in speed (addition of block load). Therefore, it will take the engine a longer time to regain speed and supply the total power requirement of the load. If the regulator is set to act as a constant voltage type, care must be taken to keep block load applications small enough so that the engine can recover in acceptable time.

[Previous Screen](#)

< Product: NO EQUIPMENT SELECTED  
Model: NO EQUIPMENT SELECTED  
Configuration: NO EQUIPMENT SELECTED

## Systems Operation

### Caterpillar Digital Voltage Regulator (CDVR)

Media Number -RENR7941-00

Publication Date -12/01/2003

Date Updated -12/19/2003

i01933220

## Voltage Regulation

SMCS - 4467

The parameters that are related to voltage regulation are listed below.

- Rated Generator Voltage
- Generator PT Primary Voltage Rating
- Generator PT Secondary Voltage Rating
- Voltage Setpoint
- Generator Frequency
- Knee Frequency
- Integral Gain
- Derivative Gain
- Proportional Gain
- Loop Gain

Once startup has been achieved and the generator output frequency is above the corner frequency, the regulator will normally act to keep the generator output voltage constant. As changes in generator loading cause the voltage to sag or rise, the regulator will automatically adjust generator excitation to maintain the output voltage. If loading causes the generator frequency to drop below the knee frequency, the loading and stopping profile as previously described will be followed. See System Operation, "Loading And Stopping Profile".

A remote voltage adjust toggle switch may be used to fine tune the generator output voltage. When used, the active value of voltage reference may be adjusted  $\pm 10\%$ .

The PC software can be used in order to adjust the voltage also. Clicking on the "Raise" and "Lower" buttons on the "Metering" screen will raise or lower the reference voltage. Each click of the "Raise" button will increment the voltage by 0.1 V. Each click of the "Lower" button will decrement the voltage by 0.1 V.

---

Copyright 1993 - 2005 Caterpillar Inc.  
All Rights Reserved.  
Private Network For SIS Licensees.

Mon Feb 14 08:14:40 EST 2005

[Previous Screen](#)

< Product: NO EQUIPMENT SELECTED  
Model: NO EQUIPMENT SELECTED  
Configuration: NO EQUIPMENT SELECTED

## Systems Operation

### Caterpillar Digital Voltage Regulator (CDVR)

Media Number -RENR7941-00

Publication Date -12/01/2003

Date Updated -12/19/2003

i01933223

## Line Loss Compensation

### SMCS - 4467

In some installations where a single generator is used with long feeder lines to the load, it may be advantageous to provide line loss compensation. Line loss compensation is commonly referred to as IR compensation. In this mode, a CT must be provided in order to measure the generator current.

The parameters that are related to line loss compensation are listed below.

- Rated Generator Voltage
- Generator PT Primary Voltage Rating
- Generator PT Secondary Voltage Rating
- Voltage Setpoint
- Generator Frequency
- Knee Frequency
- Integral Gain
- Derivative Gain
- Proportional Gain
- Loop Gain
- Generator CT Current Primary Rating
- Generator CT Current Secondary Rating
- Load Comp Mode

- IR Compensation
- Rated Generator Current

Current flowing through a long conductor causes a voltage drop due to the resistance of the wire. Therefore, the voltage at the load end of the conductor will be lower than the voltage at the generator end due to the voltage drop along the conductor. This condition is commonly referred to as line losses. In order to improve the power quality, the digital voltage regulator can compensate for this phenomenon. As generator load increases, the regulator will cause the output voltage to rise slightly at the generator terminals in order to compensate for line losses. Voltage gain controls the amount of compensation. It should be adjusted to yield a constant voltage at the location of the load.

Line loss compensation is mutually exclusive to reactive voltage droop. These two functions work opposite of one another and can not be used at the same time. If a CT is provided but line loss compensation is not desired, the setpoint percent must be set to zero.

[Previous Screen](#)

< Product: NO EQUIPMENT SELECTED  
Model: NO EQUIPMENT SELECTED  
Configuration: NO EQUIPMENT SELECTED

## Systems Operation

### Caterpillar Digital Voltage Regulator (CDVR)

Media Number -RENR7941-00

Publication Date -12/01/2003

Date Updated -12/19/2003

i01933441

## Reactive Voltage Droop

SMCS - 4467

Parameters that are related to voltage regulation with reactive droop are listed below.

- Rated Generator Voltage
- Generator PT Primary Voltage Rating
- Generator PT Secondary Voltage Rating
- Voltage Setpoint
- Generator Frequency
- Knee Frequency
- Integral Gain
- Derivative Gain
- Proportional Gain
- Loop Gain
- Generator CT Current Primary Rating
- Generator CT Current Secondary Rating
- Load Comp Mode
- Droop Percentage
- Rated Generator Current

When generators operate in parallel, two primary objectives are for the generators to share both the real power requirements and the reactive power requirements of the system electrical load. The engine governors will control sharing of the real power requirements (kW) and the voltage regulator will control sharing of the reactive power requirements (KVAR) of the total system load. If the output voltage of one generator is slightly higher than the other generators, it will supply lagging reactive current to the other generators connected in the group. This current will circulate between generators, possibly causing ampere overloading. One method of minimizing this effect is to cause an individual generator's output voltage to sag, or "droop", in proportion to the lagging reactive current flow from it as measured with a current transformer (CT). For proper reactive load sharing, the regulator must know the rated generator output current, the CT current at rated generator current and the desired percentage of output voltage droop when the generator is at rated reactive output current.

As reactive lagging generator output current increases, the regulator will cause the output voltage to droop (lower the voltage) proportionally. If the measured reactive output current is leading, the output voltage will rise. In either case, this action will tend to reduce the reactive current for better KVAR sharing with other units. The droop percentage controls how much the generator output voltage will vary for a given amount of reactive current. It is important that the connected CT polarity is correct for the voltage to droop with lagging current flow. Reactive droop compensation is mutually exclusive to line droop compensation. These two functions work opposite of one another and can not be used at the same time.

[Previous Screen](#)

< Product: NO EQUIPMENT SELECTED  
Model: NO EQUIPMENT SELECTED  
Configuration: NO EQUIPMENT SELECTED

## Systems Operation

### Caterpillar Digital Voltage Regulator (CDVR)

Media Number -RENR7941-00

Publication Date -12/01/2003

Date Updated -12/19/2003

i01933453

## Cross Current Compensation

SMCS - 4467

Parameters related to voltage regulation with cross current compensation (CCC) are listed below.

- Rated Generator Voltage
- Generator PT Primary Voltage Rating
- Generator PT Secondary Voltage Rating
- Voltage Setpoint
- Generator Frequency
- Knee Frequency
- Integral Gain
- Derivative Gain
- Proportional Gain
- Loop Gain
- Generator CT Current Primary Rating
- Generator CT Current Secondary Rating
- Load Comp Mode
- Droop Percentage
- Rated Generator Current

Cross current compensation is often used to minimize circulating current flow between the generators which are connected in parallel. The advantage of this operating mode is that all generators contribute in order to establish the same output voltage to the load. Cross current compensation is only used for paralleling multiple gensets. Cross current compensation is not used when paralleling with a utility. Operation is similar to the reactive voltage droop mode except that the secondary circuits of the current transformers of all generators are interconnected in a series string. Each generator is initially adjusted in order to provide the same output voltage. When all generators share the same current, in magnitude and phase (according to the CT ratio), there will be no significant current output on the secondary of any generator CT. If one of the generators carries more current or the current that the generator carries is lagging or leading relative to the others, a net difference current signal will be created in that CT. If that generator is supplying more reactive (lagging) current than other generators, the phase polarity and the magnitude of the signal returned to the digital voltage regulator will be such to cause a slight decrease in the generated voltage, reducing the amount of reactive current. Less reactive (or more leading) current will cause the generator voltage to rise. The net result is that the generated voltage and the output current of each generator is trimmed toward an operating point where all generators will share the same load current in proportion to the CT ratio, with the little or no circulating current between them. Droop percentage controls the amount of individual generator voltage droop (or rise) for a given amount of CT signal.

However, because the CT secondary circuits are all interconnected, the CT signal seen by any individual regulator is not representative of the actual current flowing in that particular generator. Any display or calculations that might use that signal as if it were the actual generator current will provide erroneous results.

Reactive voltage droop needs to be selected and an enable contact needs to be closed in order to enable cross current compensation. See Testing and Adjusting, "Wiring Diagrams" for a wiring diagram of the cross current compensation circuit.

[Previous Screen](#)

< Product: NO EQUIPMENT SELECTED  
Model: NO EQUIPMENT SELECTED  
Configuration: NO EQUIPMENT SELECTED

## Systems Operation

### Caterpillar Digital Voltage Regulator (CDVR)

Media Number -RENR7941-00

Publication Date -12/01/2003

Date Updated -12/19/2003

i01933462

## KVAR Regulation

SMCS - 4467

Parameters that are related to KVAR regulation are listed below.

- Rated Generator Voltage
- Generator PT Primary Voltage Rating
- Generator PT Secondary Voltage Rating
- Voltage Setpoint
- Generator Frequency
- Knee Frequency
- Integral Gain
- Derivative Gain
- Proportional Gain
- Loop Gain
- Rated Generator Current
- Generator CT Current Primary Rating
- Generator CT Current Secondary Rating
- Operating Mode
- VAR Setpoint

- VAR Integral Gain
- VAR Loop Gain

When the generator is connected in parallel with an infinite bus (utility), the voltage of the generator is controlled by the infinite bus. The voltage of the generator will change as the infinite bus voltage changes. It is not possible to control the system voltage when the generator is connected to an infinite bus. In this instance, it is necessary for the digital voltage regulator to regulate the reactive power output which is supplied by the generator. There are two methods for regulating the reactive power output.

- KVAR Regulation
- Power Factor (PF) Regulation

**Note:** KVAR stands for Kilo-Volt-Ampere-Reactive, which is the unit of measurement for reactive power.

Voltage is regulated by the digital voltage regulator in the KVAR operating mode so that the generator produces a constant value of reactive power (KVARs) regardless of the real power output of the generator. In this case, the power factor (generator) will change when the real power output of the generator changes. A current transformer (CT) is necessary for this mode to work. KVAR mode must be selected in the "Metering" screen, and the contact for the KVAR/PF enable must be closed. Refer to the following contacts: "P9-6" and "P9-9".

In KVAR mode, the generator will supply a constant amount of reactive power to the system as set by the reference (KVAR) regardless of the real power output (kW) of the generator set. The generator will supply real power (kW) to the system. This is determined by the engine governor and/or the device that is used for sharing the load. Typically utility loads are too reactive. This can cause current overloading of the system due to large reactive current requirements. In the KVAR mode, the generator can supply a fixed amount of reactive power to the system.

For stable operation of the generator in the KVAR regulating mode, the generator must be connected to a utility or a system that is much larger than the generator. When the breaker (tie) is closed to the utility, connect terminal P9-9 and terminal P9-6 in order to enable the KVAR mode. When the terminal P9-9 and terminal P9-6 are disconnected from each other, the regulator will be in a voltage control operating mode with the following or without the following: droop and line loss compensation.

[Previous Screen](#)

< Product: NO EQUIPMENT SELECTED  
Model: NO EQUIPMENT SELECTED  
Configuration: NO EQUIPMENT SELECTED

## Systems Operation

### Caterpillar Digital Voltage Regulator (CDVR)

Media Number -RENR7941-00

Publication Date -12/01/2003

Date Updated -12/19/2003

i01933601

## Power Factor Regulation

SMCS - 4467

Parameters that are related to PF regulation are listed below.

- Rated Generator Voltage
- Generator PT Primary Voltage Rating
- Generator PT Secondary Voltage Rating
- Voltage Setpoint
- Generator Frequency
- Knee Frequency
- Integral Gain
- Derivative Gain
- Proportional Gain
- Loop Gain
- Rated Generator Current
- Generator CT Current Primary Rating
- Generator CT Current Secondary Rating
- Operating Mode
- PF Setpoint

- PF Integral Gain
- PF Loop Gain

When the generator is connected in parallel with an infinite bus (utility), the voltage of the generator is controlled by the infinite bus. The voltage of the generator will change as the infinite bus voltage changes. It is not possible to control the system voltage when the generator is connected to an infinite bus. In this instance, it is necessary for the digital voltage regulator to regulate the reactive power output which is supplied by the generator. There are two methods for regulating the reactive power output.

- KVAR Regulation
- Power Factor Regulation

**Note:** KVAR stands for kilo-Volt-Ampere-Reactive, which is the unit of measurement for reactive power.

When the digital voltage regulator is in the power factor operating mode, it regulates so that the generator produces a constant power factor, regardless of the real power output of the generator. In this case, the reactive current will change when the real power output of the generator changes. A current transformer (CT) is necessary for this mode to work. PF operating mode must be selected.

For stable operation of the generator in the PF regulating mode, the generator must be connected to a utility or system that is much larger than the generator. When the tie breaker is closed to the utility, connect terminals P9-9 and P9-6 in order to enable the PF mode. When the terminals P9-9 and P9-6 are disconnected from each other, the regulator will be in a voltage control operating mode with or without droop or line loss compensation as previously described. "PF" mode must be selected in metering screen and the "KVAR/PF" contact must be closed. Refer to the following contacts: "P9-6" and "P9-9". When the contact is not closed the regulator operates in AVR mode.

[Previous Screen](#)

< Product: NO EQUIPMENT SELECTED  
Model: NO EQUIPMENT SELECTED  
Configuration: NO EQUIPMENT SELECTED

## Systems Operation

### Caterpillar Digital Voltage Regulator (CDVR)

Media Number -RENR7941-00

Publication Date -12/01/2003

Date Updated -12/19/2003

i01935584

## Parameters

SMCS - 4467

## General Information

Parameters are pieces of information which are used within the memory of the digital voltage regulator. Each parameter has a specific range of values. Parameters tell the digital voltage regulator how to operate. Service personnel can configure certain parameters to the requirements of a specific site. Configuration changes the value of a particular parameter. There is an upper and lower limit for the value of each parameter. The limits can not be exceeded.

In order to view or configure the values of the parameters see Testing And Adjusting, "Parameter Viewing And Configuring Procedure".

[Previous Screen](#)

< Product: NO EQUIPMENT SELECTED  
Model: NO EQUIPMENT SELECTED  
Configuration: NO EQUIPMENT SELECTED

## Systems Operation

### Caterpillar Digital Voltage Regulator (CDVR)

Media Number -RENR7941-00

Publication Date -12/01/2003

Date Updated -12/19/2003

i01938981

## Remote Communication

SMCS - 4467

The digital voltage regulator has the capability to communicate with a remote personal computer or programmable logic controller. The J4 connector of the digital voltage regulator provides an RS-232 port necessary for communication. The RS-232 port is a 9-pin communication media including a wire for Receive, a wire for Transmit, and a common Signal Ground. The common signal ground is NOT a bonding ground and should not be grounded to the case or frame. It is to be connected to the RS-232 device Signal Ground connection point. Cable length should be limited to 15 m (50 ft) maximum for the RS-232 signal wiring.

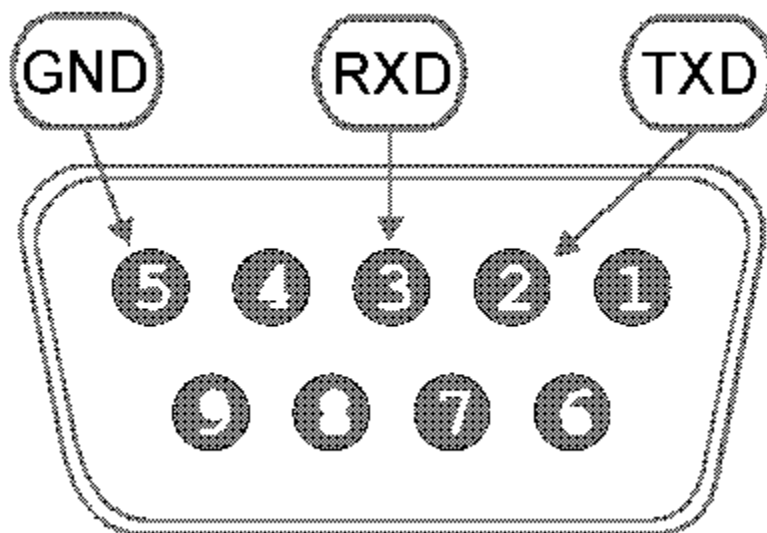

Illustration 1

g01008946

Table 1

Pin	Function	Name	Direction
1	-	-	N/A
2	Transmit Data	TXD	From Regulator
3	Receive Data	RXD	To Regulator
4	-	-	N/A
5	Signal Ground	GND	N/A
6	-	-	N/A
7	-	-	N/A
8	-	-	N/A
9	-	-	N/A

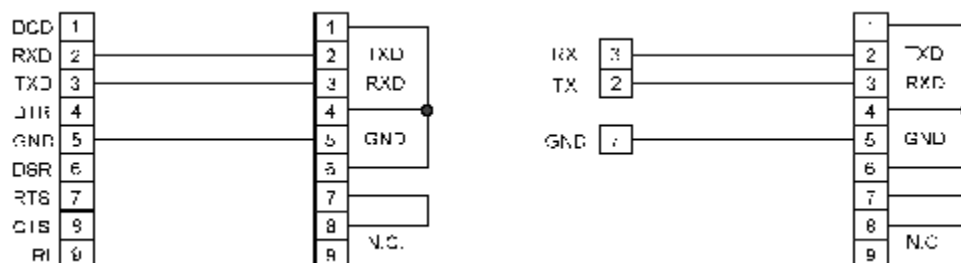

Illustration 2

g01008993

**Note:** Battery power (24 Vdc) must be available at P12-8 (B+) and P12-7 (B-) in order for the remote communications port to operate.

A windows program is available to communicate with the digital voltage regulator. The program is called Caterpillar PC Software. For proper connection of the digital voltage regulator to the personal computer, see Testing and Adjusting, "Wiring Diagrams", the illustration Remote Communications.

Caterpillar PC Software allows the user to perform the following operations.

- Viewing and modifying the parameters in a windowed PC environment
- Sending the parameters to the digital voltage regulator
- Saving the existing digital voltage regulator settings to a file

- Viewing the metering and fault information

For information on changing and viewing the parameters of the voltage regulator, see Testing and Adjusting, "Parameter Viewing and Configuring Procedure".

## Establishing Communication

Communication between the voltage regulator and the PC software must be established before viewing the metering values, reading settings, or changing settings. PC software screen settings are updated only after communication is opened or the communication settings have been changed. Open the voltage regulator communication port by clicking "Communications" on the menu bar, hovering the mouse pointer over "Open Comm Port" and clicking "RS-232 Port".

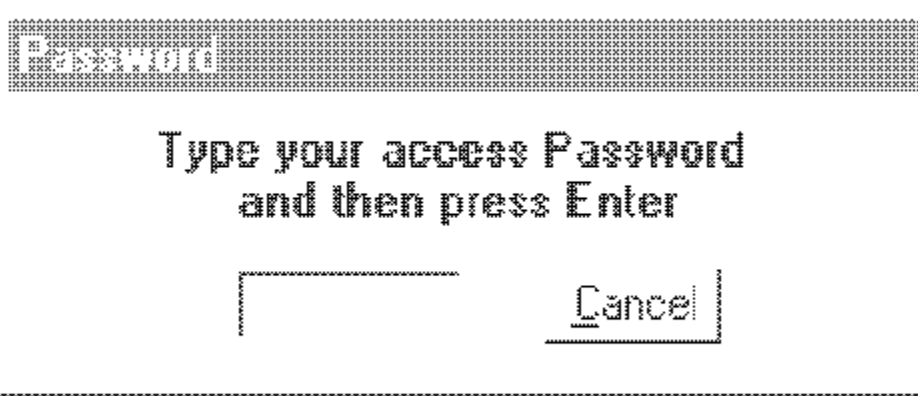

---

Illustration 3

g01016734

When "RS-232 Port" is selected, the "Password" dialog box appears and prompts you to enter a password. See illustration 3. Each voltage regulator is delivered with "cat" as the password.

---

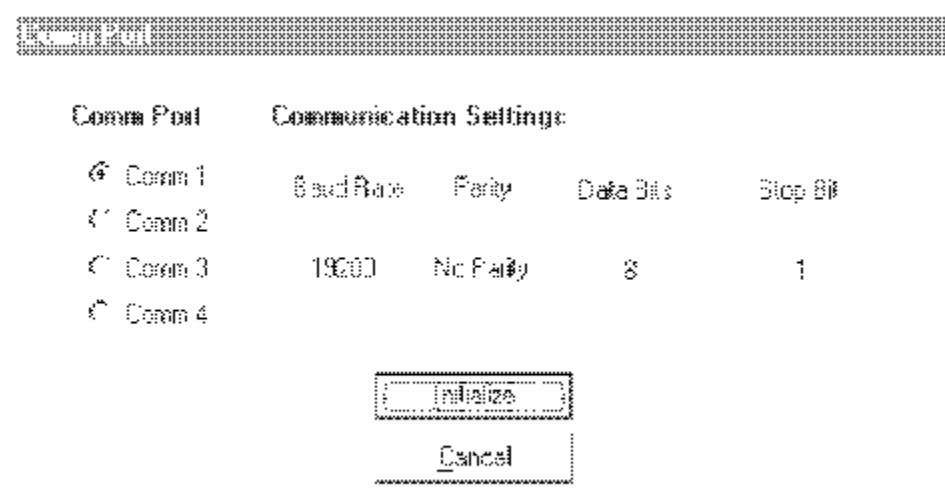

Illustration 4

g01016736

After the correct password is entered, the "Comm Port" screen is displayed. See illustration 4. Select "Comm 1", "Comm 2", "Comm 3", or "Comm 4" as the active communication port on your PC and click the "Initialize" button. The PC software initializes communication by obtaining the configuration settings from the voltage regulator.



Illustration 5

g01016737

**Note:** The Caterpillar PC software may display the "Please wait..." dialog box that is shown in

illustration 5 when initializing communication, obtaining configuration settings, or performing other tasks. It is important to wait until the box disappears before trying to execute communication commands. Issuing commands while the "Please wait..." dialog box is present may disrupt communication between the PC software and the voltage regulator.

## Terminating Communication

Voltage regulator communication is terminated by clicking "Communications" on the menu bar and clicking "Close Comm Port". The user will be prompted to save the settings to the EEPROM. This question is asked even if no changes were made to the voltage regulator settings. When the close command is execute (with a Yes or No to save settings to the EEPROM), communication with the voltage regulator is terminated. If the PC software is exited the (by clicking File on the Menu bar and then Exit) without first closing communication, the option will still be given to save the settings to the EEPROM.

[Previous Screen](#)

< Product: NO EQUIPMENT SELECTED  
Model: NO EQUIPMENT SELECTED  
Configuration: NO EQUIPMENT SELECTED

## Testing and Adjusting

### Caterpillar Digital Voltage Regulator (CDVR)

Media Number -RENR7941-00

Publication Date -12/01/2003

Date Updated -12/19/2003

i01942916

## General Information

SMCS - 4467

## PREVENTATIVE MAINTENANCE

The only preventive maintenance that is required on the voltage regulator is to periodically check that the connections between the voltage regulator and the system are clean and tight. Voltage regulator units are manufactured using state-of-the-art, surface-mount technology. As such, Caterpillar recommends that no repair procedures be attempted by anyone other than Caterpillar dealer technicians.

---

Copyright 1993 - 2005 Caterpillar Inc.  
All Rights Reserved.  
Private Network For SIS Licensees.

Mon Feb 14 08:21:47 EST 2005

[Previous Screen](#)

< Product: NO EQUIPMENT SELECTED  
Model: NO EQUIPMENT SELECTED  
Configuration: NO EQUIPMENT SELECTED

## Testing and Adjusting

### Caterpillar Digital Voltage Regulator (CDVR)

Media Number -RENR7941-00

Publication Date -12/01/2003

Date Updated -12/19/2003

i01041654

## Service Tools

SMCS - 0785

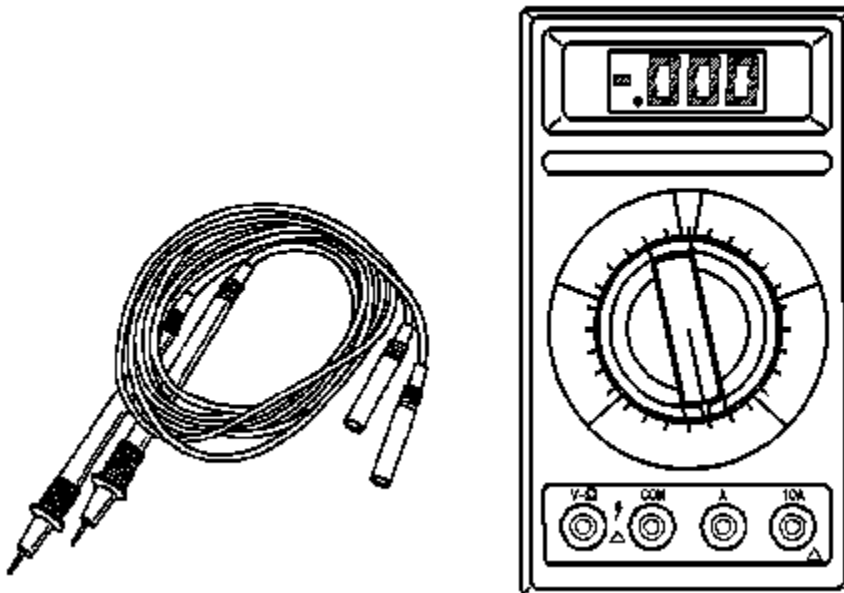

Illustration 1  
6V-7070 Caterpillar Digital Multimeter

g00241203

Caterpillar Digital Multimeters can be used to measure voltage, resistance or current up to 10 amperes. Rectifiers can also be checked by using the diode function. See Special Instruction, SEHS7734, "Use Of The 6V-7070 And 6V-7800 Multimeter" for the correct operation of the **6V-7070** Digital Multimeter.



---

Illustration 2                      g00538441  
8T-0900 AC/DC Clamp-On Ammeter

The **8T-0900** Ammeter may be used to measure current up to 1200 amperes. When you are measuring line current on multiple lead units, measure the current in each conductor per phase and add the currents together. See Special Instruction, SEHS8420, "Using the 8T900 AC/DC Clamp-On Ammeter 0651" for the correct operation of the **8T-0900** Ammeter.

[Previous Screen](#)

< Product: NO EQUIPMENT SELECTED  
Model: NO EQUIPMENT SELECTED  
Configuration: NO EQUIPMENT SELECTED

## Testing and Adjusting

### Caterpillar Digital Voltage Regulator (CDVR)

Media Number -RENR7941-00

Publication Date -12/01/2003

Date Updated -12/19/2003

i01991688

## Startup Procedure

SMCS - 4467

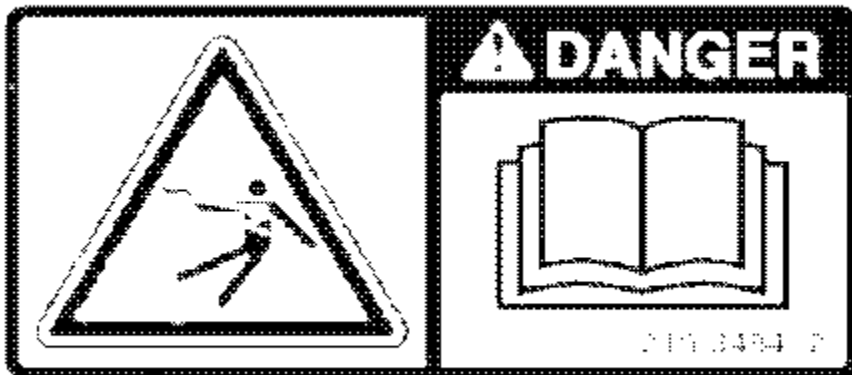

Illustration 1

g01021519

A black rectangular sign with a white exclamation mark inside a triangle on the left and the word 'DANGER' in white, bold, sans-serif capital letters on the right.

**The Cat Digital Voltage Regulator presents an electrical shock/electrocution hazard. This hazard will cause serious injury or death.**

**Service by trained personnel only.**

**The terminals and heat sinks are live at hazardous voltages when power is applied and for up to 8 minutes after power is removed.**

---

1. Connect the digital voltage regulator. Refer to Testing And Adjusting, "Wiring Diagrams" for a proper illustration. Take care to follow notes and observe polarities.
2. Apply battery power only to the digital voltage regulator. Verify that all of the parameters are properly adjusted for the application.
3. Start the engine. Make the final adjustments, as required.
4. Record all settings.

[Previous Screen](#)

< Product: NO EQUIPMENT SELECTED  
Model: NO EQUIPMENT SELECTED  
Configuration: NO EQUIPMENT SELECTED

## Testing and Adjusting

### Caterpillar Digital Voltage Regulator (CDVR)

Media Number -RENR7941-00

Publication Date -12/01/2003

Date Updated -12/19/2003

i01956126

## Parameter Viewing and Configuring Procedure

SMCS - 4467

In order to view and configure the parameters of the digital voltage regulator, a PC with the Caterpillar PC software is required.

**Note:** Before performing this procedure, study the list of parameters in order to determine the desired parameter and the corresponding range of values. The value of some parameters are only for viewing by the user and may not be configurable.

**Note:** It will be convenient to have the entire list of parameters available while performing this procedure. See System Operation, "Parameters"

The Caterpillar PC Software provides the communication link between the voltage regulator and the user. All voltage regulator settings are entered and read through this software. Within this software, voltage regulator settings can be saved in a computer file and used later to configure other units with the same settings.

Caterpillar PC Software operates with an IBM-compatible personal computers (PCs) using Microsoft Windows 95 or later operating systems. The minimum recommended operating requirements are listed below:

- IBM-compatible PC, 486DX2 or faster (100 MHz or higher microprocessor is recommended)
- CD-ROM drive
- One available serial port

## Installing the Caterpillar PC Software

Caterpillar PC Software contains a setup utility that installs the program on the PC. An uninstall utility is loaded with the program that can be used to remove the application from the PC. Use the following procedure to install the PC software.

1. Insert the CD-ROM into the PC's CD-ROM drive
2. Click the Windows Start button and then select "Run". In the "Open:" field, enter "D:/Setup.exe", where D is the designator letter for your PC CD-ROM drive. Then click "OK".

When Caterpillar PC Software is installed, a folder with the name Caterpillar is added to the Windows program menu. This folder is accessed by clicking the "Start" button and pointing to "Programs".

## Starting Caterpillar PC Software

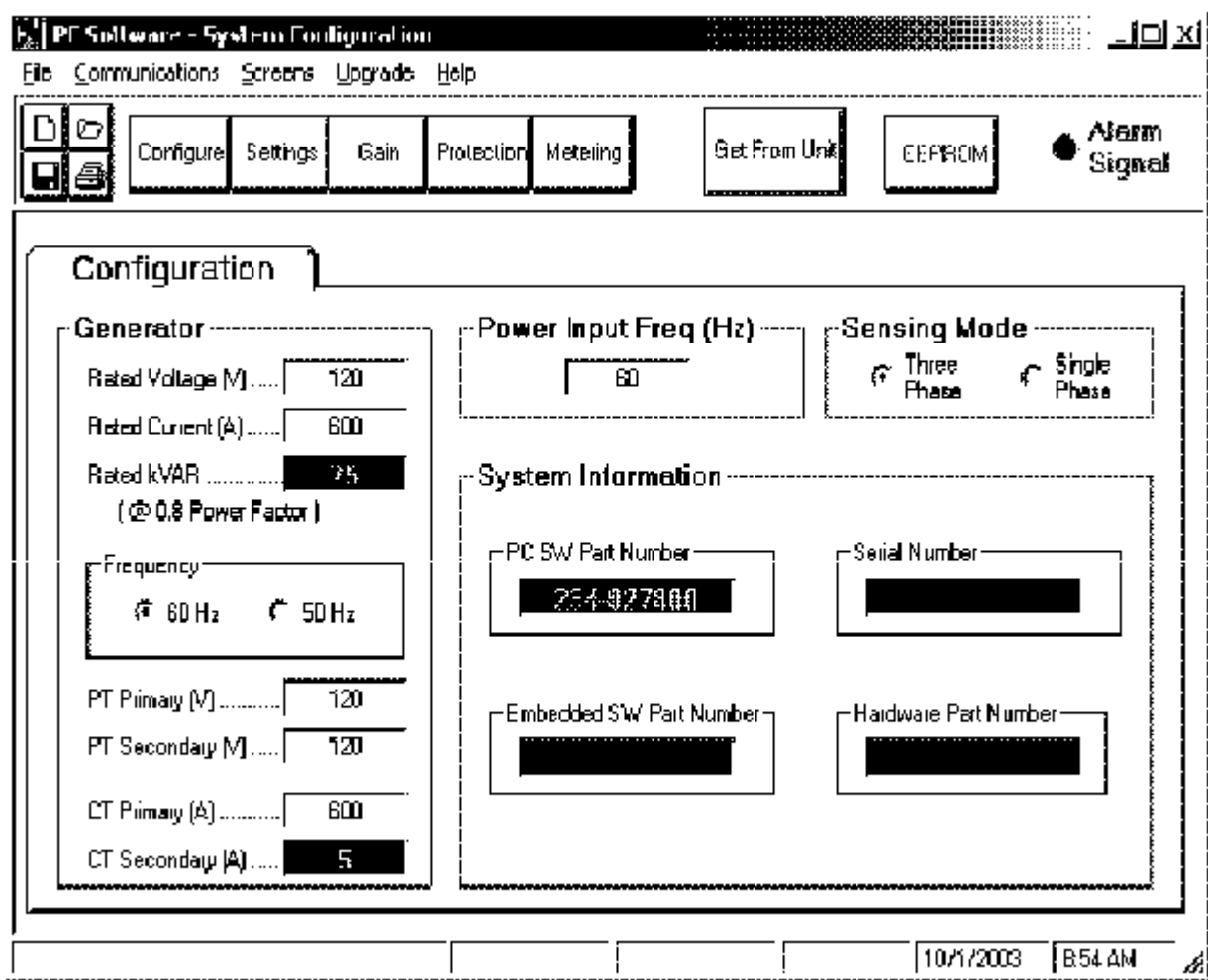

Illustration 1

g010:

The PC software is started by clicking the Windows "Start" button, pointing to "Programs", the "Caterpillar" folder, and then clicking the voltage regulator icon. At startup, a dialog box with the program title and version number is displayed briefly. After this dialog box is displayed, the "System Configuration" screen is displayed. See Illustration 1.

## Establishing Communication

Communication between the voltage regulator and the PC must be established before any settings can be viewed or changed. For more information on establishing communications, see Systems Operation, "Remote Communication"

## Changing Settings

The settings are arranged into the following five groups:

- System configuration
  - Setting Adjustments
  - Control Gain Settings
  - Protections Settings
  - Metering/Operation and Alarms
-

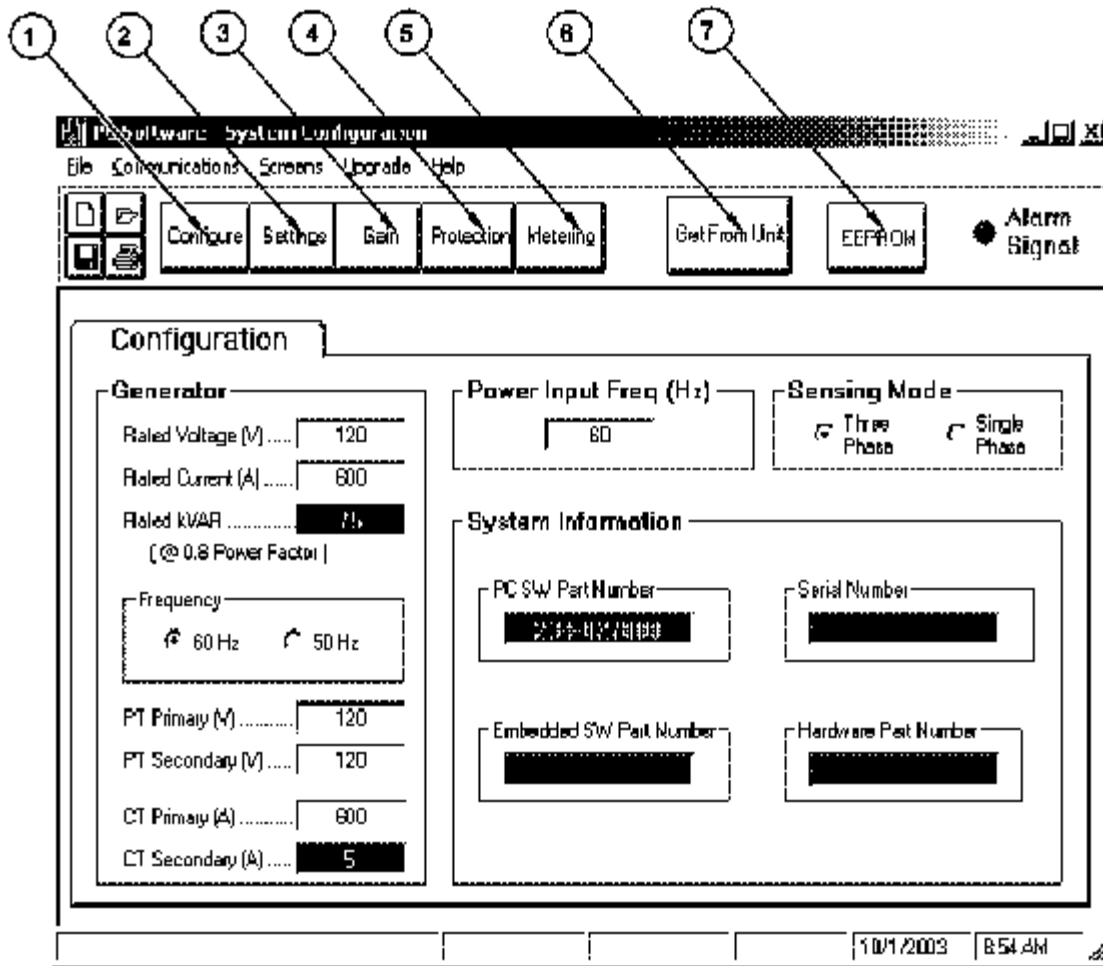

Illustration 2  
Systems Configuration screen

g010:

- (1) System Configuration button
- (2) Setting Adjustment button
- (3) Control Gain Button
- (4) Protection Setting button
- (5) Metering/Operation button
- (6) Get From Unit button
- (7) EEPROM button

Each setting group has a corresponding button that can be selected to access that group of settings. See Illustration 2. The five setting groups can also be accessed by clicking "Screens" on the menu bar and then selecting the desired setting group from the list. Once a setting group is accessed, the individual settings of the group can be viewed and changed.

A setting is changed by clicking within the setting field and typing the setting. The minimum, maximum and increments (steps) for a setting are displayed on the status bar when the cursor is placed within that setting field. A changed setting is sent to the voltage regulator when the Enter key on the PC is pressed. A setting in a field with the pull-down menu is sent to the voltage regulator when the setting is selected from the pull-down menu.

## **Sending and Receiving Settings**

When communication is enabled, voltage regulator settings can be sent or received through the PC software.

### **Sending Settings**

Settings changes are sent to the voltage regulator by pressing the Enter key on the PC or by selecting a setting from a pull-down menu. This causes the selected setting displayed on the setting screen to become the voltage regulator setting.

### **Receiving Settings**

Voltage regulator settings are retrieved by clicking the "Get From Unit" button (6). This causes the current settings of the voltage regulator to be displayed on the "settings" screen.

### **Saving Settings to the Memory of the Voltage Regulator**

Settings are saved in nonvolatile memory (EEPROM). In the event of a power loss, these are the settings that will be active at start-up. If the settings are changed and sent to the voltage regulator, but the settings are not sent to the EEPROM, the changed settings will be lost if the operating power to the voltage regulator is lost. When exiting an application or closing communication, the software will prompt the user to save the settings to the EEPROM. This question is asked even if no changes were made to the settings. When communication is enabled, setting changes are saved to the EEPROM by clicking the "EEPROM" button (7). The opportunity to save the settings to the EEPROM is also given through a dialog box when the application is exited or communication is closed.

## **Setting Definitions**

Each of the five setting groups have a corresponding screen in the PC software. The setting of each screen are categorized by one or more tabs. In the following paragraphs, setting are arranged and defined according to the organization of the PC application screens and tabs.

### **System Configuration**

The "System Configuration" screen consists of one tab labeled "Configuration". Click the "Configure" button (1) in order to access the "System Configuration" screen or click "Screens" on the menu bar and click "System Configuration".

#### **Configuration Tab**

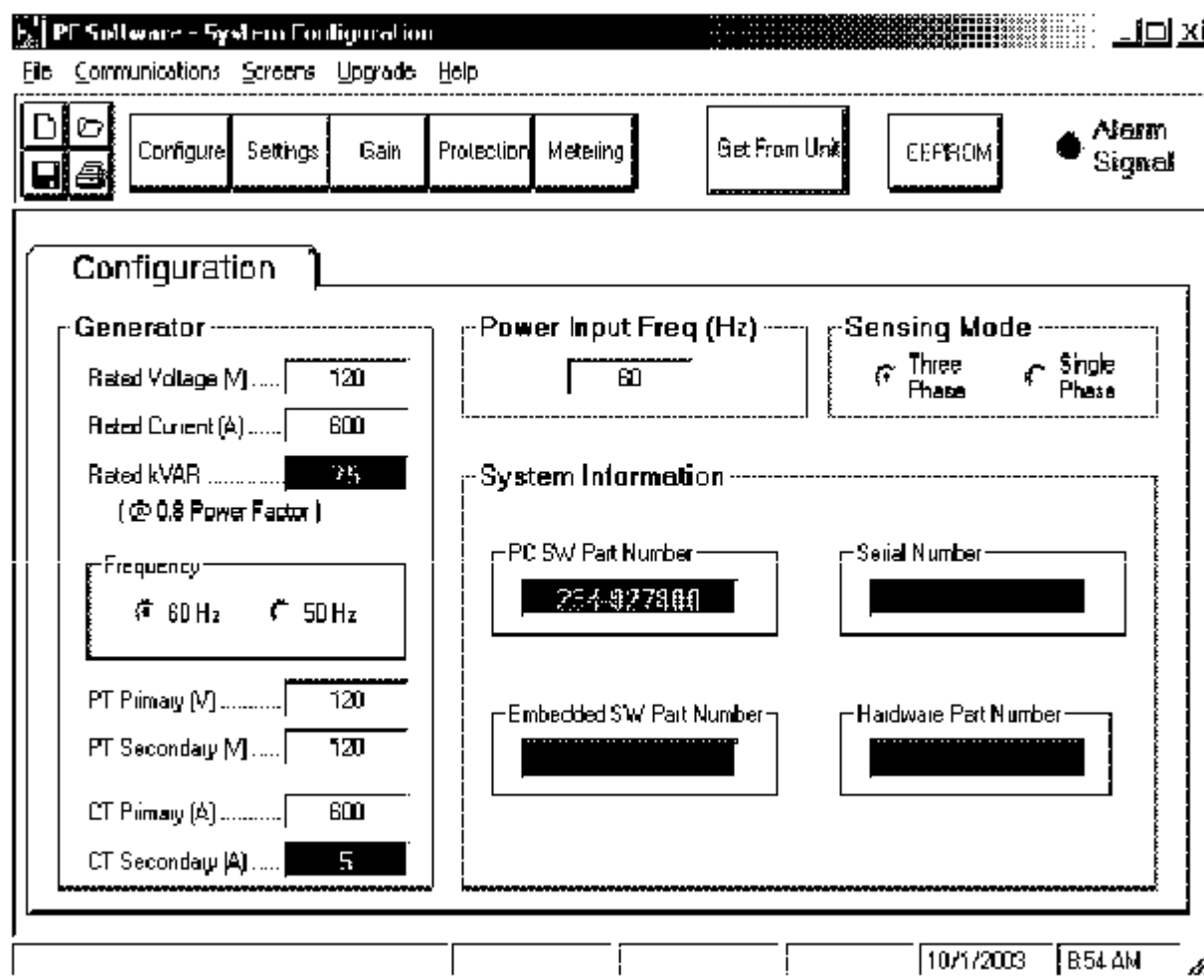

Illustration 3

g010:

**Rated Voltage (V)** - The rated AC generator voltage is entered in this field. Voltages within the range of 90 to 15000 ACV may be entered in 1 ACV increments.

**Rated Current (A)** - The maximum rated AC generator current is entered in this setting field. Currents within the range of 75 to 9999 Amperes may be entered in 1 Amperes increments.

**Rated kVAR** - This field is a read-only field that displays the rated, calculated reactive power, based on the values that are entered in the Rated Voltage and Rated current fields.

**Frequency** - This setting is used to select a nominal system operating frequency of 50 Hz or 60Hz.

**PT Primary (V)** - The primary AC voltage rating of the potential transformer (PT) is entered in this field. Voltages within the range of 90 and 15000 ACV may be entered in 1 ACV increments.

**PT Secondary (V)** - The secondary AC voltage rating of the PT is entered in this field. Voltages within the range of 90 and 600 ACV may be entered in 1 ACV increments.

**CT Primary** - The AC current rating of the primary winding of the CT is entered in this field. Currents within the range of 75 to 9999 Amperes may be entered in 1 Amperes increments.

**CT Secondary** - This field is a read-only field that displays the rated value of the current that is present at the secondary winding of the CT. This regulator is designed for a 5 Ampere secondary winding only.

**Power Input Frequency (Hz)** - The frequency value of the operating power applied to the voltage regulator is entered in this field. This would be the frequency of the permanent magnet generator or the frequency of the generator in the case of self-excited generator. Frequencies within the range of 50 to 400 Hz may be entered in 1 Hz increments.

**Sensing Mode** - This setting is used to configure the voltage regulator for the single-phase or three-phase voltage sensing.

**PC Software Part Number** - This is a read-only field that displays the version of the PC software part number.

**Embedded Software Part Number** - This is a read-only field that displays the version of the embedded software part number.

**Hardware Part Number** - This is a read-only field that displays the version of the Hardware part number.

**Serial Number** - This is a read-only field that displays the serial number of the voltage regulator connected to the PC. Communication between the voltage regulator and the PC must be enabled in order to read the firmware version.

## Setting Adjustments

The "Setting Adjustments" screen consists of two tabs labeled "Setpoint" and "Startup". Click the "Settings" button (2) in order to access the "Setting Adjustments" screen or click "Screens" on the menu bar and click "Setting Adjustments".

### Setpoint Tab

---

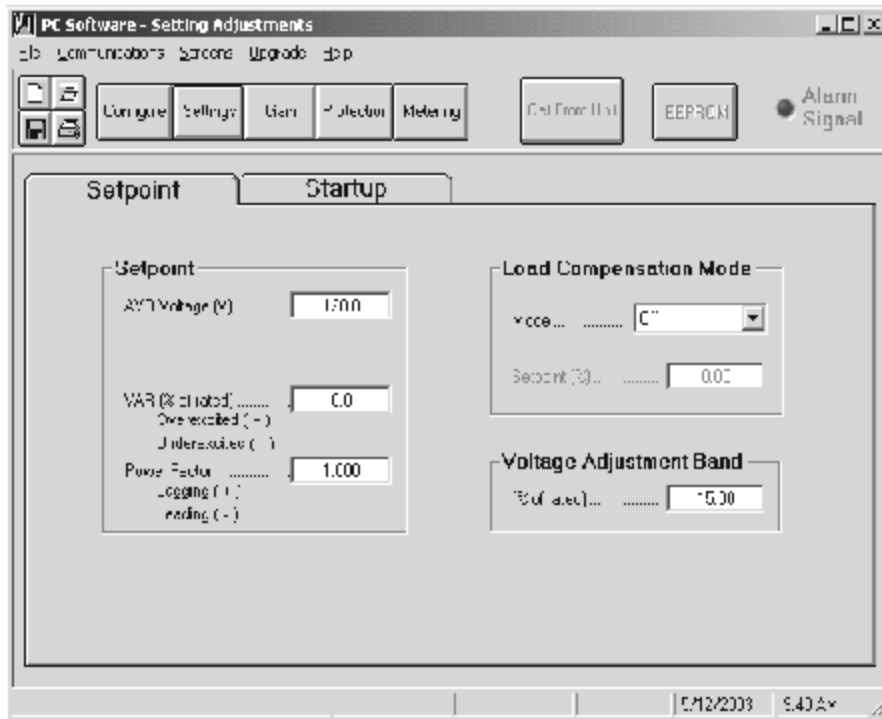

Illustration 4

g01009341

**AVR Voltage (V)** - This setting field is used to enter the desired generator output terminal voltage. The range of voltages is dependent on the value in the "Voltage Adjustment Band (% of rated)" field. Values may be entered in increments of 0.1 ACV.

**VAR (% of rated)** - The VAR setpoint determines the level of generator VARs that are maintained by the voltage regulator when the digital voltage regulator is in the VAR mode. Percentage values within the range of -100 to 100 percent may be entered in increments of 0.1 percent. A setting in the overexcited direction will have a positive value and a setting in the underexcited direction will have a negative value.

**Power Factor** - The Power Factor setpoint determines the level of generator power factor that is maintained by the voltage regulator when the voltage regulator is in the power factor mode. Settings within the range of -1.000 to 1.000 may be entered in increments of 0.001. A setting in the lagging direction will have a positive value and a setting in the leading direction will have a negative value.

**Load Compensation Mode: Mode** - Three settings may be selected from the drop-down menu for this operating mode: Off, Droop, or Line Drop. Selecting Off disables all load compensation. Selecting Droop enables the reactive droop compensation feature of the voltage regulator. Selecting Line Drop enables the voltage regulator to compensate for a line drop by increasing the generator output voltage as the generator load increases.

**Load Compensation Mode: Setpoint (%)** - This setting field is enabled only when Droop or Line Drop is selected as the Load Compensation mode. A percentage of zero to 10.00 percent may be entered in increments of 0.01.

**Voltage Adjustment Band (% of rated)** - This setting is entered as a percentage of the rated generator voltage and is used to limit the range of the AVR setpoint. A percentage value of zero to 15.00 percent may be entered in increments of 0.01.

## Startup Tab

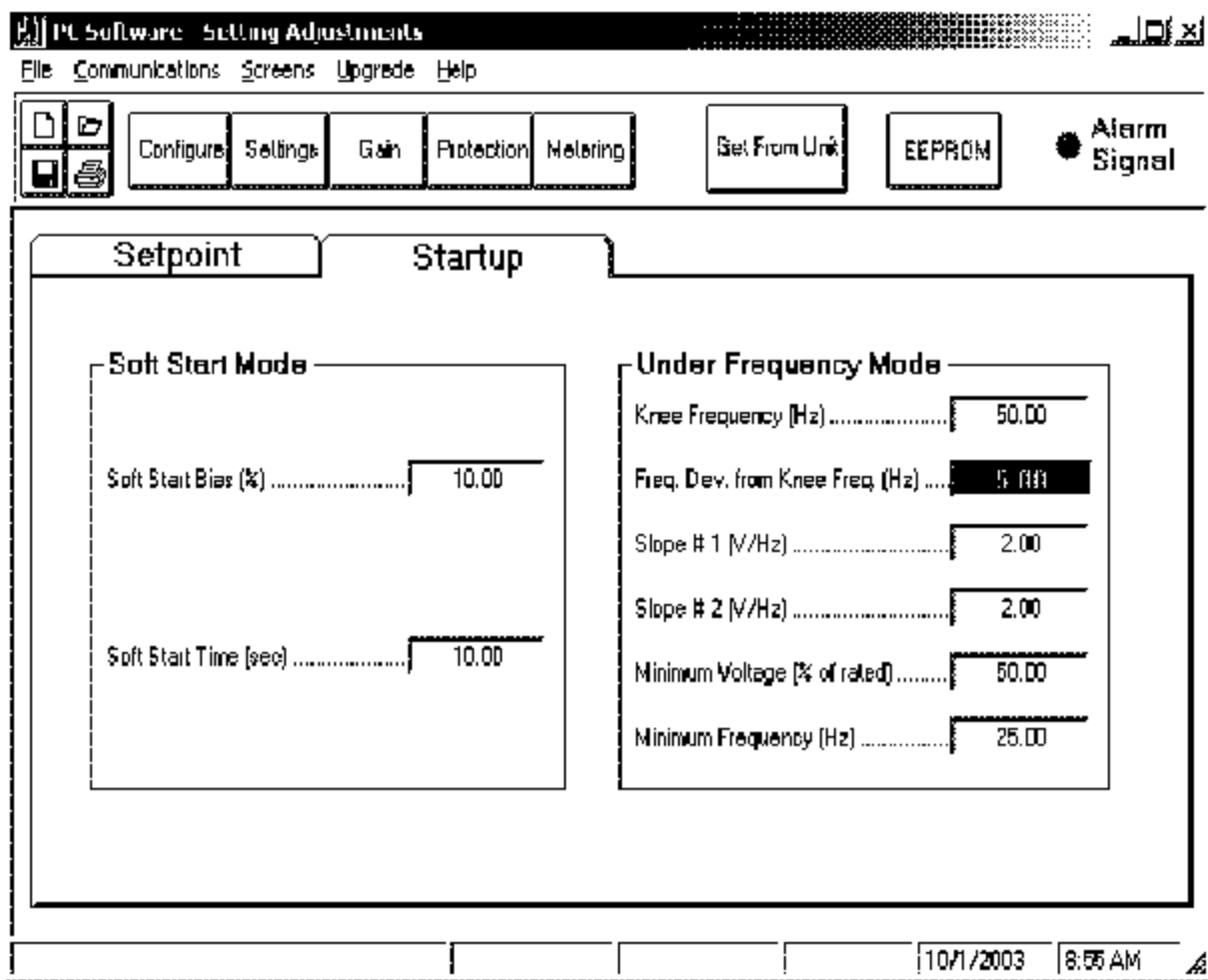

Illustration 5

g010:

**Soft Start Bias (%)** - The Soft Start Bias setting determines the generator voltage offset during startup. A percentage value of 0.00 to 90.00 may be entered in increments of 0.01 percent.

**Soft Start Time (sec)** - The Soft Start Time establishes the length of time for the generator terminal voltage to increase to the prescribed level. A value of 0.00 to 120.00 seconds may be entered in increments of 0.01 seconds.

**Knee Frequency (Hz)** - The Knee Frequency setting defines the value of frequency that causes the voltage regulator to adjust the voltage setpoint so that the generator terminal voltage follows the selected volts per hertz slope. A value of 45.00 to 65.00 hertz may be entered in increments of 0.01 hertz. Knee

Frequency should typically be set from 0.2 to 2 Hz less than than the Genset operating frequency. The knee frequency should be adjusted closer to the nominal frequency in applications where the Genset engine and governor is slow in recovering frequency during a transient load event.

**Freq. Dev. from Corner Freq. (Hz)** - This field is a read-only field. The fixed value is subtracted from the Corner Frequency value in order to determine when the generator underfrequency operation changes from slope 1 to slope 2.

**Slope #1 (V/Hz)** - When the generator frequency is between the corner frequency and the corner frequency minus 5 hertz, the voltage setpoint is automatically adjusted so that the generator voltage follows volts per hertz slope 1. Slope #1 is adjusted by this setting field. A setting of zero to 10.00 may be entered in increments of 0.01.

**Slope # 2 (V/Hz)** - When the generator frequency is between the corner frequency minus 5 hertz and the "Minimum Frequency" setting, the voltage setpoint is automatically adjusted so that the generator voltage follows volts per hertz slope #2. Slope #2 is adjusted by this setting field. A setting of zero to 10.00 may be entered in increments of 0.01.

**Note:** Volts per Hz slope value can be used to improve transient response time.

**Minimum Voltage (% of rated)** - The Minimum Voltage setting defines the voltage level where the voltage regulator transitions from the underfrequency characteristic to a constant voltage characteristic. The Minimum Voltage setting is expressed as a percentage of nominal generator voltage. A value of 50.00 to 100.00 percent may be entered in increments of 0.01.

**Minimum Frequency (Hz)** - The Minimum Frequency setting defines the value of the generator frequency where the excitation is removed. A frequency value of 20.00 to 40.00 hertz may be entered in increments of 0.01 hertz.

## Control Gain

The Control Gain screen consists of a single tab labeled "Control Gain". Click the "Gain" button (3) in order to access the "Control Gain" screen or click "Screens" on the menu bar and click "Control Gain".

### Control Gain Tab

---

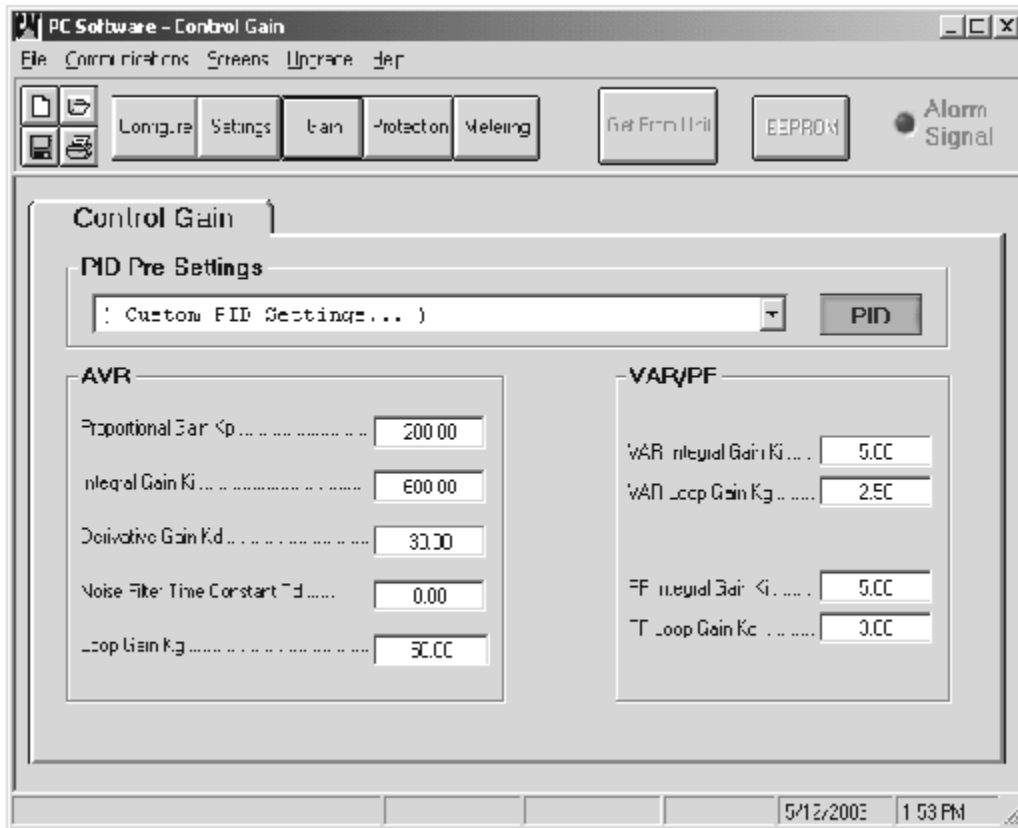

Illustration 6

g01009752

**Proportional Gain  $K_p$**  - This setting selects the proportional constant stability parameter. The voltage regulator supplies a value that is equivalent to  $K_p$  multiplied by the error between the voltage setpoint and the actual generator output voltage.  $K_p$  values of 0 to 1,000 may be entered in increments of 0.01.

If the transient response has too much overshoot, then  $K_p$  may be decreased. If the transient response is too slow, then  $K_p$  may be increased.

**Integral Gain  $K_i$**  - This setting selects the integral constant stability parameter. The voltage regulator supplies a value that is equivalent to  $K_i$  multiplied by the integral of the error between the voltage setpoint and the actual generator output voltage.  $K_i$  values of 0 to 1,000 may be entered in increments of 0.01.

Increasing the value of  $K_i$  decreases the time required to reach steady state.

**Derivative Gain  $K_d$**  - This setting selects the derivative constant stability parameter. The voltage regulator provides an output value that is equivalent to  $K_d$  multiplied by the derivative of the error between the voltage setpoint and the actual generator output voltage.  $K_d$  values of 0 to 1,000 may be entered in increments of 0.01.

Increasing the value of  $K_d$  reduces transient response ringing.

**Noise Filter Time Constant Td** - This setting selects the noise filter time constant and is used in order to reduce high-frequency noise. Values of 0.00 to 1.00 may be entered in increments of 0.01.

**Loop Gain Kg** - This setting adjusts the loop-gain level of the PID algorithm. Loop Gain values of 0 to 1,000 may be entered in increments of 0.01. Loop gain Kg is an overall gain multiplier affecting all gain parameters, and should be used as a first gain adjustment. Increasing Loop Gain may be used to increase transient response and reduce time to steady state. Decreasing loop gain will reduce overshoot but will lengthen time to steady state.

**VAR Integral Gain Ki** - This setting adjusts the integral gain and determines the characteristic of the voltage regulator dynamic response to a changed VAR setting. Ki values of 0 to 1,000 may be entered in increments of 0.01.

**VAR Loop Gain Kg** - This setting adjusts the loop-gain level of the PI algorithm for VAR control. Values of 0 to 1,000 may be entered in increments of 0.01.

**PF Integral Gain Ki** - This setting adjusts the integral gain and determines the characteristic of the voltage regulator dynamic response to a changed power factor setting. Values of 0 to 1,000 may be entered in increments of 0.01.

**PF Loop Gain Kg** - This setting adjusts the loop-gain level of the PI algorithm for power factor control. Values of 0 to 1,000 may be entered in increments of 0.01.

**PID Pre-Settings** - One of 20 preset stability ranges within the voltage regulator can be selected from this pull-down menu. Selection of one of the 20 preset stability ranges disables the Proportional Gain (Kp), Integral Gain (Ki), and Derivative Gain (Kd) settings of the Control Gain tab. Selecting "(Custom PID Settings)" from the PID Pre-Settings menu enables the Kp, Ki, and Kd settings. Caterpillar does not recommend using the current "PID Pre-Settings" in the list except the "Custom PID Settings". The default settings from the "Custom PID Settings" will work well for most SR4 and SR4B generator applications. If an adjustment is to be made, the "Loop Gain Kg" should be used as a first adjustment approach.

**"PID" Button** - Press the PID button in order to open the PID Calculator screen. See illustration 7. The PID Calculator is used in order to calculate proportional gain (Kp), integral gain (Ki), and derivative gain (Kd) for a PID-type controller. The generator and the exciter time constant values are entered into the PID Calculator in order to calculate these values. AVR overall gain (Kg) and derivative filter time constant Td can be entered and saved in a file. Refer to the "PID Calculator" section for additional information.

## **PID Calculator**

---

Illustration 7

g01009819

The PID parameters are calculated for the desired system response with a settling time of about one-third of the generator time constant and about 10 percent overshoot.

### Excitation Control Data

**Gen. Information** - Up to 20 characters of descriptive text for the generator can be entered in this field. When a PID record is created, this text identifies the record.

**Gen Time Constant [T'do]-[Seconds]** - The open-circuit generator time constant (T'do) can be selected from this pull-down menu. Time constant values of 1 to 15 seconds can be entered in 0.05 second increments.

**Note:** Values for specific generators can be obtained from the Technical Marketing Information System.

**Exciter Time Constant [Te]-[Seconds]** - The exciter time constant (Te) can be selected from this pull-down menu. The value displayed in this menu depend on the generator time constant (T'do) that is selected. Available values range from one-fiftieth to one-half of T'do in 0.01 second increments. The maximum possible exciter time constant is 3 seconds.

**Default Exciter Time Constant** - When this box is checked, manual selection of the exciter time constant is disabled and Te is set at one-sixth the value of the generator time constant (T'do). This is not recommended for SR4 and SR4B generators.

### AVR Control Parameters

**Proportional Gain (Kp)** - This is a read-only value. The value is calculated from the values that are selected from the generator time constant (T'do) and exciter time constant (Te) pull-down menus.

**Integral Gain (Ki)** - This is a read-only value. The value is calculated from the values that are selected from the generator time constant (T'do) and exciter time constant (Te) pull-down menus.

**Derivative Gain (Kd)** - This is a read-only value. The value is calculated from the values selected from the generator time constant (T'do) and exciter time constant (Te) pull-down menus.

**Time Constant (Td)** - The time constant value entered in this field is used to reduce high-frequency noise. The Td value entered is recommended to be less than 0.2 (Kd , Kp). Td values from zero to 1.00 may be entered in 0.01 increments. Entering a value of zero disables the filtering.

**AVR Overall Gain (Kg)** - The AVR overall gain is entered in this field. A Kg value of zero to 1000.00 may be entered.

### PID Record List

This area of the PID Calculator screen lists all of the saved PID records that are available.

**Remove Record Button** - Records in the PID Record List can be selected and deleted by clicking this button.

**Add Record Button** - A record containing the excitation control data and AVR control parameters can be added to the PID Record List by clicking this button. The "Save" button must be pressed in order to save the record in the list.

**Update CAT PC Software Button** - Transfers the AVR control parameters calculated in the PID calculator and recorded to the Control Gain Screen.

**Close Button** - Clicking this button closes the PID Calculator and returns to the Control Gain screen.

Table 1

Power Input to Voltage Regulator(PM / SE / AREP Systems)					Power Input to Exciter				
					Nominal Requirements				F Rec
	SE/PM Voltage	Input to Regulator	Frequency Range	Number of Phases	Exciter Nominal Voltage Input	Exciter Nominal Current Input	Exciter Resistance	Exciter Time Constant Te	Fu For Vol
Kato 2600 Frame	PM	70 to 105V	240 Hz	3	35V	10A	3.7 ohms	0.22 sec	65V

Kato 2800 Frame	PM	120V	90 Hz	1	50V	5A	10 ohms	0.18 sec	90V
6100	PM	140V	120 Hz	3	40V	4A	10 ohms	0.22 sec	60V
6100	SE	140V	60 Hz	1	40V	4A	10 ohms	0.22 sec	60V
6100	AREP	140V	50/180 Hz	2x1	40V	4A	10 ohms	0.22 sec	60V
1400 /4P	PM	180V	200/240 Hz	3	45V	4.5A	10 ohms	0.056 sec	80V
1400 /4P	SE		50/60 Hz		45V	4.5A	10 ohms	0.056 sec	
1400 /4P	AREP	140V	50/180 Hz	2x1	45V	4.5A	10 ohms	0.056 sec	80V
1600 /4P	PM	180V	200/240 Hz	3	60V	6A	10 ohms	0.059 sec	150
1600 /4P	SE		50/60 Hz		60V	6A	10 Ohms	0.059 sec	
1600 /4P	AREP	240 V	50/180 Hz	2x1	60V	6A	10 ohms	0.059 sec	150
1800 /4P	PM	180V	240 Hz	3	84V	4A	21 ohms	0.22 sec	190
1800 /4P	SE	240V	60 Hz	1	84V	4A	21 ohms	0.22 sec	190
1800 /4P	AREP	240V	60 Hz	1	84V	4A	21 ohms	0.22 sec	190
SR4	PM	70 to 105V	240 Hz	3	35V	10A	3.7 ohms	0.22 sec	65V
SR4	SE	240V	60 Hz	1	35V	10A	3.7 ohms	0.22 sec	65V

## Protection Settings

The "Protection Settings" screen consists of a single tab labeled "Protection". Click the "Protection" button to access the "Protection Settings" screen or click "Screens" on the menu bar and click "Protection Settings".

## Protection Tab

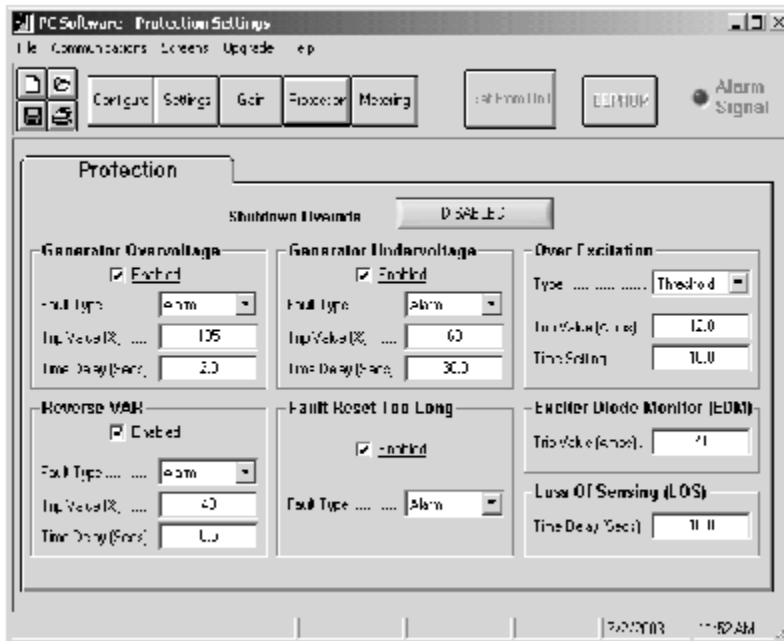

Illustration 8

g01009884

**"SHUTDOWN OVERRIDE" Button** - This button is used to prevent excitation shutdown for any protected function. The button displays "ENABLED" when selected and the button displays "DISABLED" when the button is deselected.

**Generator Overvoltage: Enabled** - Selecting the "Enabled" checkbox enables generator overvoltage protection. Deselecting the Enabled checkbox disables generator overvoltage protection and the associated settings.

**Generator Overvoltage: Fault Type** - Two options can be selected from this pull-down menu, "Alarm" or "Shutdown". When "Alarm" is selected and a generator overvoltage condition is detected, the Alarm output driver energizes, a J1939 alarm message is sent via the CAN communication port, and the Fault LED will be lit constantly. For units equipped with an RS-232 communication port, an Alarm fault will be annunciated via the PC software. When "Shutdown" is selected and a generator overvoltage condition is detected, the Fault Shutdown output driver energizes, a J1939 shutdown message is sent, and the Fault LED will flash. For units equipped with an RS-232 communication port, a Shutdown fault will be annunciated via the PC software. **The voltage regulator does NOT disable excitation when a Generator Overvoltage fault is detected.**

**Generator Overvoltage: Trip Value (%)** - This setting determines the voltage threshold where an overvoltage trip will occur. Voltage values of 105 to 135 percent of the rated voltage may be entered in increments of 1 percent.

**Generator Overvoltage: Time Delay (Secs)** - This setting assigns the length of time from when an overvoltage condition is detected until the voltage regulator issues an alarm or shuts down excitation. A time value of 2.0 to 30 seconds may be entered in 0.1 second increments.

**Reverse VAR: Enabled** - Selecting the "Enabled" checkbox enables reverse VAR protection. Deselecting the Enabled checkbox disables reverse VAR protection and the associated settings.

**Note:** If Reverse VAR protection is enabled and the CT connections are reversed, a reverse VAR alarm or shutdown will occur.

**Reverse VAR: Fault Type** - Two options can be selected from this pull-down menu, "Alarm" or "Shutdown". When "Alarm" is selected and loss of excitation is detected, the Alarm output driver energizes, a J1939 alarm message is sent via the CAN communication port, and the Fault LED is lit constantly. For units equipped with an RS-232 communication port, an Alarm fault will be annunciated via the PC software. When "Shutdown" is selected and loss of excitation is detected, the Fault Shutdown output driver energizes, a J1939 shutdown message is sent via the CAN communication port, and the Fault LED flashes. For units equipped with an RS-232 communication port, a Shutdown fault will be annunciated via the PC software. The voltage regulator does NOT disable excitation when a Loss of Excitation (Reverse var) fault is detected.

**Reverse VAR: Trip Value (%)** - This setting determines the level of reverse VAR flow, expressed as a percentage of nominal, positive VAR flow, where a loss of excitation trip occurs. A value of 10 to 100 percent may be entered in increments of 1 percent.

**Reverse VAR: Time Delay (Secs)** - This setting assigns the length of time from when the reverse VAR trip value is exceeded until the voltage regulator issues an alarm or shuts down. A time value of 0.1 to 9.9 seconds may be entered in 0.1 second increments.

**Generator Undervoltage: Enabled** - Selecting the "Enabled" checkbox enables generator undervoltage protection. Deselecting the "Enabled" checkbox disables generator undervoltage protection and the associated settings.

**Generator Undervoltage: Fault Type** - Two options can be selected from this pull-down menu, "Alarm" or "Shutdown". When "Alarm" is selected and generator undervoltage is detected, the Alarm output driver energizes, a J1939 alarm message is sent via the CAN communication port, and the Fault LED is on constantly. For units equipped with an RS-232 communication port, an Alarm fault will be annunciated via the PC software. When "Shutdown" is selected and generator undervoltage is detected, the Shutdown output driver energizes, a J1939 shutdown message is sent via the CAN communication port, and the Fault LED flashes. For units equipped with an RS-232 communication port, a Shutdown fault will be annunciated via the PC software. The voltage regulator does NOT disable excitation when a Generator Undervoltage fault is detected.

**Generator Undervoltage: Trip Value (%)** - This setting determines the level of voltage, expressed as a percentage of nominal generator voltage, where a generator undervoltage trip occurs. A value of 60 to 95 percent may be entered in 1 percent increments.

**Generator Undervoltage: Time Delay (Secs)** - This setting assigns the length of time from when a generator undervoltage condition is detected until the voltage regulator issues an alarm or shuts down excitation. A time value of 10.0 to 120.0 seconds may be entered in 0.1 second increments.

**Over Excitation: Type** - Two options can be selected from this pull-down menu, "Inv Time" (for inverse curves) or "Threshold" (for a fixed time delay). The voltage regulator disables excitation when an overexcitation fault is detected unless a global Shutdown Override command is in effect.

**Over Excitation: Trip Value (Amps)** - This setting determines the level of field current that will cause an overexcitation trip. Values of 0 to 12.0 amperes may be entered in 0.1 amperes increments. The required value for the SR4 and SR4B generators is 12 amperes.

**Over Excitation: Time Delay (Secs)** - This setting assigns the length of time from when an overexcitation condition is detected and when the voltage regulator issues an alarm or shuts down the excitation. A time value of 1.0 to 10.0 seconds may be entered in 0.1 second increments. The required value for the SR4 and SR4B generators is 10 seconds.

**Exciter Diode Monitor (EDM): Trip Value (Amps)** - This setting determines the level of current that is indicative of a failed exciter diode. If the current level exceeds the diode fault threshold setpoint for five seconds, a diode fault is detected. The voltage regulator disables excitation when a diode fault is detected unless a global Shutdown Override command is in effect. A value of 1.0 to 10.0 amperes may be entered in 0.1 ampere increments.

**Loss of Sensing (LOS): Time Delay (Secs)** - The value of this setting determines the time delay between when a loss of sensing voltage is recognized and the voltage regulator responds by removing the field excitation. A time value of zero to 25.0 seconds may be entered in 0.1 second increments.. The voltage regulator disables excitation when a Loss of Generator Sensing fault is detected unless a global Shutdown Override command is in effect.

**Fault Reset Too Long: Enabled** - Selecting the "Enabled" checkbox enables the voltage regulator to issue an alarm or a shut down fault if the fault reset input is closed longer than 10 seconds.

**Fault Reset Too Long: Fault Type** -. Two options can be selected from this pull-down menu, "Alarm" or "Shutdown". When "Alarm" is selected and the Fault Reset contact input remains closed for more than 10 seconds, the Alarm output driver energizes, a J1939 alarm message is sent via the CAN communication port, and the Fault LED lights constantly. For units equipped with an RS-232 communication port, an Alarm fault will be annunciated via the PC software. When "Shutdown" is selected and the Fault Reset contact input remains closed for more than 10 seconds, the Fault Shutdown output driver energizes, a J1939 alarm message is sent via the CAN communication port, and the Fault LED lights constantly. For units equipped with an RS-232 communication port, the voltage regulator will attempt to annunciate the Shutdown fault via the PC software. The voltage regulator does NOT disable excitation when a Fault Reset Closed Too Long condition is detected.

## Metering, Operation, and Alarms

The "Metering, Operation, and Alarms" screen consists of a single tab labeled "Metering". Click the "Metering" button to access the "Metering, Operation, and Alarms" screen or click "Screens" on the menu bar and click "Metering/Operation".

### Metering Tab

---

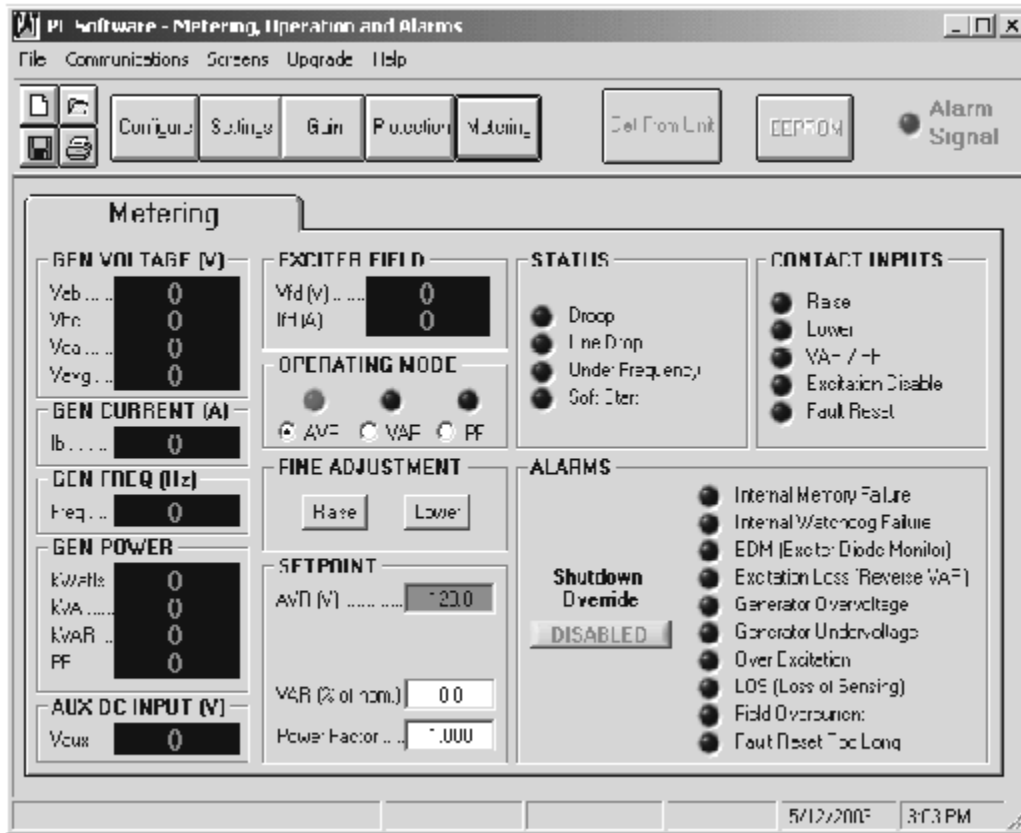

Illustration 9

g01010266

**GEN VOLTAGE (V): Vab** - This field is a read-only field that displays the phase-to-phase voltage of phase A and phase B.

**GEN VOLTAGE (V): Vbc** - This field is a read-only field that displays the phase-to-phase voltage of phase B and phase C.

**GEN VOLTAGE (V): Vca** - This field is a read-only field that displays the phase-to-phase voltage of phase C and phase A.

**GEN VOLTAGE (V): Vavg** - This field is a read-only field that displays the average value of the three phase-to-phase voltages.

**GEN CURRENT (A): Ib** - This field is a read-only field that displays the value of the current on the B-phase of the generator.

**GEN FREQ (Hz): Freq** - This field is a read-only field that displays the value of the frequency of the generator voltage.

**GEN POWER: kWatts** - This field is a read-only field that displays the value of real power that is being output from the generator.

**GEN POWER: kVA** - This field is a read-only field that displays the value of apparent power that is being output by the generator.

**GEN POWER: kVAR** - This field is a read-only field that displays the value of reactive power that is being output by the generator.

**GEN POWER: PF** - This field is a read-only field that displays the value of the power factor that the generator is operating at.

**AUX DC INPUT (V): Vaux** - This field is a read-only field that displays the level of dc control voltage that is applied from a remote device to the voltage regulator terminals P12-3 (B) and P12-6 (A).

**EXCITER FIELD: Vfd (V)** - This field is a read-only field that displays the value of the exciter field voltage.

**EXCITER FIELD: Ifd (A)** - This field is a read-only field that displays the value of the exciter field current.

**OPERATING MODE** - One of three operating modes may be selected as active: "AVR", "VAR", or "PF". When an operating mode is active, the corresponding indicator color changes from black to red for "AVR" mode. When an operating mode is active, the corresponding indicator color changes from black to green for the "VAR" mode and the "PF" mode.

**Note:** When either KVAR or PF mode are selected, the appropriate button must be selected and the Auxiliary breaker contact that is connected to P9-6 (KVAR/PF enable contact) and P9-9 (contact sense common) must be closed.

**FINE ADJUSTMENT** - The "Raise" and "Lower" buttons control the fine adjustment of the operating setpoint. These buttons perform the same function as closing the appropriate set of contacts connected to the Contact Sense – Raise input (terminal P9-5) and Contact Sense – Lower input (terminal P9-4) of the voltage regulator. Each click of the Raise button increases the voltage setpoint by 0.1 V, each click of the Lower button decreases the voltage setpoint by 0.1 V.

**Note:** The PT ratio will affect this setting.

**SETPOINT: AVR (V)** - This setting field is used to enter the desired generator terminal voltage. The background color of this field is green when the voltage regulator is in AVR mode.

**Note:** The PT ratio will affect this setting.

**SETPOINT: VAR (% of nom.)** - This setting determines the level of generator VARs maintained by the voltage regulator when operating in VAR mode. The background color of this field is green when the voltage regulator is regulating the VAR setpoint. A percentage value of zero to 100.0 may be entered in 0.1 percent increments.

**SETPOINT: Power Factor** - This setting determines the level of power factor regulation maintained by the voltage regulator. The background color of this field is green when the voltage regulator is regulating the power factor setpoint. A power factor value of –0.600 to 0.600 may be entered in 0.001 increments.

**STATUS** - Four indicators indicate the operating status of the voltage regulator: "Droop", "Line Drop", "Under Frequency" and "Soft Start".

The Droop indicator turns red when the Reactive Droop Compensation feature is selected. The Reactive Droop Compensation feature is used during parallel generator operation to assist in the sharing of reactive load.

The Line Drop indicator turns red when the Line Drop Compensation feature is selected. The Line Drop Compensation feature is used to compensate for voltage drops in the lines between the generator and the load.

The Under Frequency indicator turns red when the generator frequency decreases below the Knee Frequency setting and excitation is terminated.

The Soft Start indicator turns red when the Soft Start feature is active to control the time for generator voltage to ramp up during startup.

**CONTACT INPUTS** - Five indicators provide the status of the voltage regulator switch inputs: "Raise", "Lower", "VAR / PF", "Excitation Disable" and "Fault Reset".

The Raise indicator turns red when contact closure at terminals P9-5 (Contact Sense – Raise) and P9-6 (Contact Sense – Common) is detected.

The Lower indicator turns red when contact closure at terminals P9-4 (Contact Sense – Lower) and P9-6 (Contact Sense – Common) is detected.

The Var/PF indicator turns red when contact closure at terminals P9-9 (Contact Sense – Var/PF Enable) and P9-6 (Contact Sense – Common) is detected.

The Excitation Disable indicator turns red when contact closure at terminals P9-7 (Contact Sense – Excitation Disable) and P9-6 (Contact Sense – Common) is detected.

The Fault Reset indicator turns red when contact closure at terminals P9-8 (Contact Sense – Fault Reset) and P9-6 (Contact Sense – Common) is detected.

**ALARMS** - Ten indicators annunciate alarm conditions. Alarm indicators include the following alarms: "Internal Memory Failure", "Internal Watchdog Failure", "Exciter Diode Monitor", "Excitation Loss", "Generator Overvoltage", "Generator Undervoltage", "Overexcitation", "Loss of Sensing", "Field Overcurrent" and "Fault Reset Too Long". When the voltage regulator detects an alarm condition, the appropriate indicator changes from black to red.

**ALARMS: Shutdown Override Status** - This indication provides the status (position) of the "Shutdown Override Button". The button displays "ENABLED" when selected and "DISABLED" when deselected.

## Settings Files

Caterpillar PC software enables you to print a list of voltage regulator settings, save voltage regulator settings in a file, and open a settings file in order to upload those settings to a voltage regulator. A

settings file may also be opened and edited with any text editing software.

## Printing the Settings Files

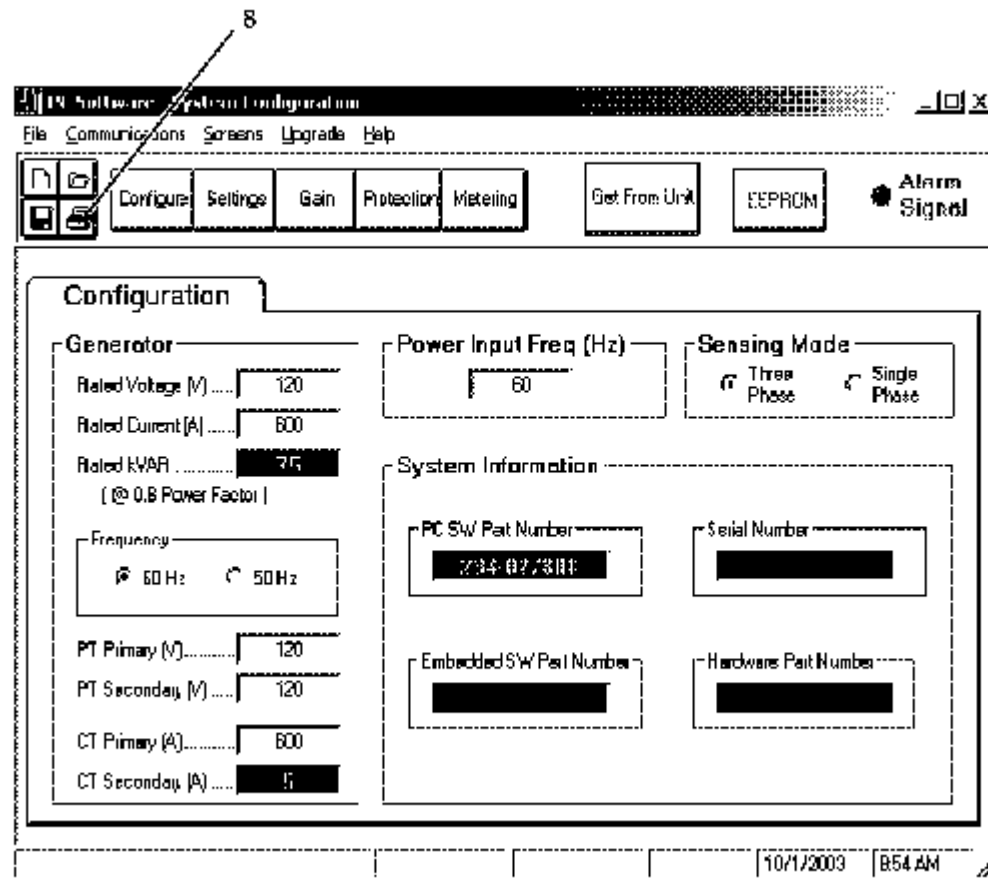

Illustration 10  
Print Icon

g010

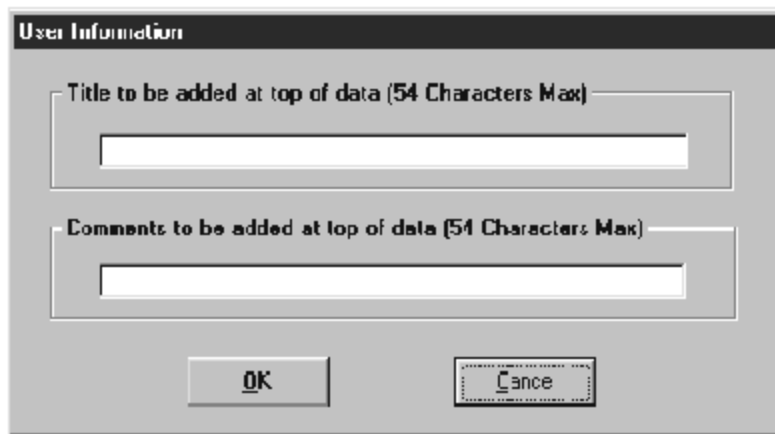

Illustration 11

g01016740

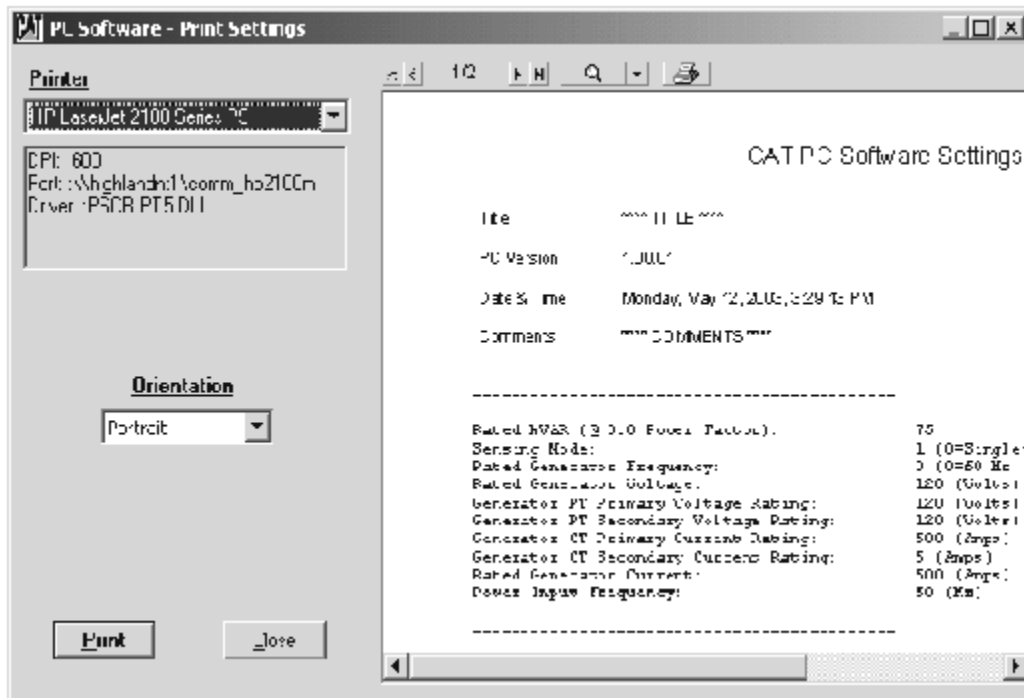

Illustration 12

g01016741

A printout of voltage regulator settings can be useful for record keeping or comparison purposes. The voltage regulator settings can be printed by clicking the print icon (1) or clicking "File" on the menu bar and then clicking "Print". When the print command is given, a dialog box provides the opportunity to add a title and comments to the settings list. See illustration 11. Each entry is limited to a maximum of 54 characters. After this information is entered, click on "OK". The "Print Settings" box will appear. See illustration 12. This dialog box is used in order to select the desired printer, change and verify the printer

settings, and preview the printed settings list. Click on the "Print" button in order to print the settings list.

## Saving the Settings Files

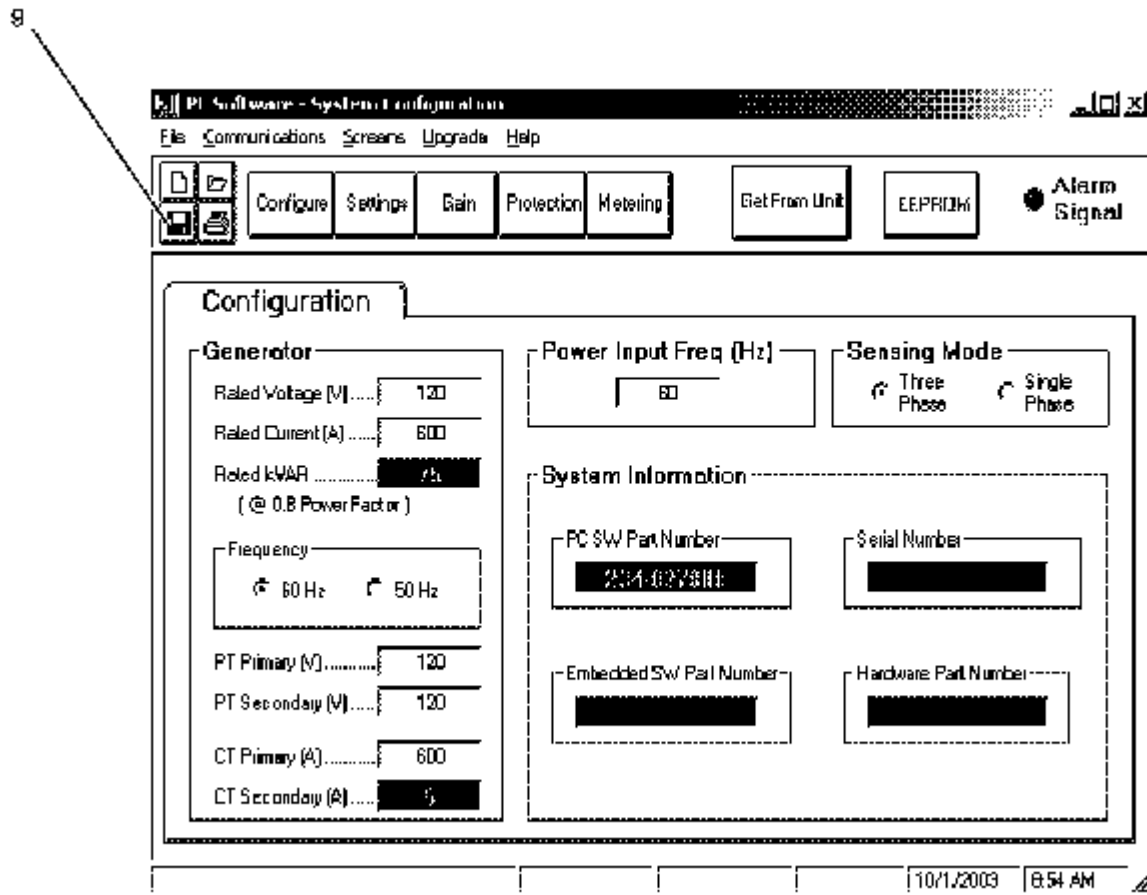

Illustration 13  
Save Icon

g0104

Saving the voltage regulator settings in a file for uploading to other voltage regulator units saves setup time when configuring multiple units with the same settings. A settings file can also be created in the PC software without being connected to a voltage regulator. The settings of the desired screens can be changed and these settings can then be saved to a file. Once a settings file is created, the file can be edited using any text editing software, and the file can then be saved for uploading.

A settings file is created by clicking the save icon (1) or by clicking "File" on the menu bar and then clicking "Save". When the command is given, a "Save As" dialog box is displayed where the settings are assigned a file name and then saved. All voltage regulator settings files are automatically given a ".dv2"

extension.

## Uploading the Settings Files to the Voltage Regulator

A voltage regulator settings file downloaded from a voltage regulator or created within the PC software can be uploaded to multiple voltage regulator units. Only a voltage regulator settings file with a ".dv2" extension can be uploaded to a voltage regulator unit. Before uploading a file, communication must be initiated with the voltage regulator that is to receive the settings. See Systems Operation, "Remote Communication".

The upload process is started by clicking the open icon or clicking "File" on the menu bar and then clicking "Open". An "Open" dialog box is then displayed where the desired settings file is navigated to and selected. Clicking "Open" uploads the settings file.

[Previous Screen](#)

< Product: NO EQUIPMENT SELECTED  
Model: NO EQUIPMENT SELECTED  
Configuration: NO EQUIPMENT SELECTED

## Testing and Adjusting

### Caterpillar Digital Voltage Regulator (CDVR)

Media Number -RENR7941-00

Publication Date -12/01/2003

Date Updated -12/19/2003

i01953257

## Troubleshooting

### SMCS - 4467

If the voltage regulator does not operate as expected, first check the programmable settings for the appropriate function. Use the following troubleshooting procedures when difficulties are encountered in the operation of the excitation system.

## Alarm or Shutdown Faults

Faults that are discussed in this section will not cause excitation to be turned off unless some external means of removing excitation is wired into the Alarm or the Shutdown Fault output driver. Shutdown faults that always cause excitation to be turned off are discussed in Testing and Adjusting, "No Voltage - Troubleshoot". Open communication with the voltage regulator in order to determine which fault condition has occurred.

If an Excitation Loss (reverse VAR) fault has occurred, a reverse VAR condition has been detected in excess of the programmed threshold for longer than the programmed time delay. If an incorrect fault detection is suspected, verify that the programmed settings are compatible with the application. If settings are correct, it is possible to get an incorrect fault detection if the generator voltage and the generator current sensing inputs to the voltage regulator are not properly wired for ABC rotation. Verify correct wiring of the generator voltage and generator current sensing inputs to the voltage regulator. See Testing and Adjusting, "Wiring Diagrams".

If a Generator Overvoltage fault has occurred, a generator overvoltage condition has been detected at the generator voltage sensing input(s) of the voltage regulator in excess of the programmed threshold for longer than the programmed time delay. See Testing and Adjusting, "High Voltage - Troubleshoot".

If a Generator Undervoltage fault has occurred, a generator undervoltage condition has been detected at the generator voltage sensing input(s) of the voltage regulator in excess of the programmed threshold for longer than the programmed time delay. See Testing and Adjusting, "Low Voltage - Troubleshoot".

If the Fault Reset contact input is closed for more than 10 seconds, a Fault Reset Too Long fault has occurred. Remove the short across the Fault Reset contact input.

Resetting the voltage regulator may be achieved either by momentarily closing the Fault Reset contact input or by cycling 24Vdc control power.

---

Copyright 1993 - 2005 Caterpillar Inc.  
All Rights Reserved.  
Private Network For SIS Licensees.

Mon Feb 14 08:24:59 EST 2005

[Previous Screen](#)

< Product: NO EQUIPMENT SELECTED  
Model: NO EQUIPMENT SELECTED  
Configuration: NO EQUIPMENT SELECTED

## Testing and Adjusting

### Caterpillar Digital Voltage Regulator (CDVR)

Media Number -RENR7941-00

Publication Date -12/01/2003

Date Updated -12/19/2003

i01954619

## No Voltage - Troubleshoot

SMCS - 4467-035

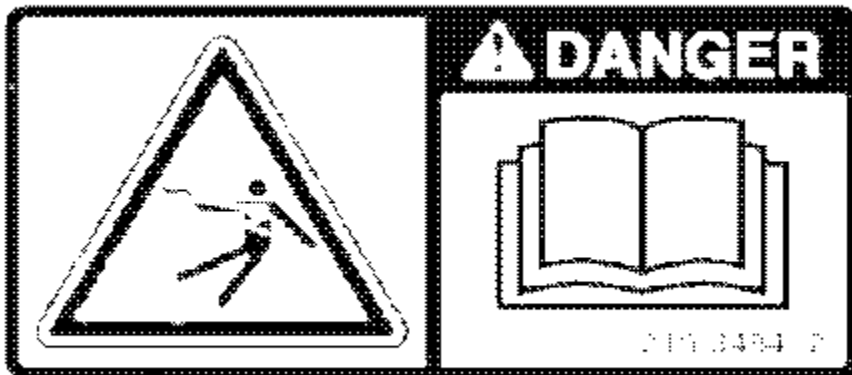

Illustration 1

g01021519

A black rectangular warning sign with a white exclamation mark inside a triangle and the word "DANGER" in white capital letters.

**The Cat Digital Voltage Regulator presents an electrical shock/electrocution hazard. This hazard will cause serious injury or death.**

**Service by trained personnel only.**

**The terminals and heat sinks are live at hazardous voltages when power is applied and for up to 8 minutes after power is removed.**

---

1. Verify that all of the wiring is properly connected. Refer to Testing and Adjusting, "Wiring Diagrams".

**OK** - If the wiring connections are correct, go to step 2.

**NOT OK** - If the wiring is improperly connected or the wiring is loose, reconnect the wiring properly.

STOP.

2. Verify that the generator is running at rated speed.

**OK** - If the generator is spinning at rated speed, go to step 3.

**NOT OK** - If the generator is not at rated speed, increase generator speed to the rated value.

STOP.

3. The digital voltage regulator is PMG power or Shunt powered.

**PMG power** - Proceed to step 4.

**Shunt Powered** - Proceed to step 5.

4. Check for correct input power to the voltage regulator. Refer to Specification, "Electrical", for input power requirements.

**OK** - If voltage is present, go to step 5.

**NOT OK** - If PMG voltage is not present, refer to the generator manual for the repair procedures and check for an open circuit.

STOP.

5. Verify that the residual voltage applied to the power input is at least 6 ACV.

**OK** - If the applied voltage is 6 ACV or greater, go to step 6.

**NOT OK** - If the applied voltage is less than 6 ACV, refer to the generator manual and flash the generator field. Install blocking diodes in series with the battery in order to prevent damage to the voltage regulator and/or the battery.

STOP.

6. Verify that the fuse is not open.

**OK** - If no fuses are open, go to step 6.

**NOT OK** - Replace any fuses that are open.

STOP.

7. Verify that the common alarm/Shutdown LED indicator on the voltage regulator is not flashing.

**OK** - If no protective fault has caused the excitation to be turned off, go to step 14.

**NOT OK** - If the LED indicator is flashing, open communications with the voltage regulator to determine if a protective shutdown fault has occurred that would cause excitation to be turned off. If protective shutdown fault has occurred that would cause excitation to be turned off, go to step 8.

8. If an Exciter Diode Monitor (EDM) fault has occurred, stop the machine, insure that the power input to the voltage regulator is removed, and unplug "P6" on the voltage regulator. Refer to the generator manual for instructions on checking the rotating exciter diodes. Have the rotating exciter diode assembly checked for open or shorted diodes. If an open or shorted diode is present in the rotating exciter diode assembly, refer to the generator manual for instructions on how to replace the rotating rectifier assembly. After repairs are complete, reset the voltage regulator by momentarily closing the Fault Reset contact or by cycling 24V control power. The generator may be restarted. If there is no problem with the rotating exciter diode assembly, the EDM trip value may be set too low. An EDM fault may occur with good rotating exciter diodes under varying loads if the trip level is set too low. Set the EDM trip level to a value greater than the RMS ripple current present in the exciter field under normal operating conditions in order to prevent a false trip. Reconnect "P6". Reset the voltage regulator by momentarily closing the Fault Reset contact or by cycling 24V control power. The generator may be restarted. If an Exciter Diode Monitor (EDM) fault has not occurred, go to step 9.
9. If an Over Excitation fault has occurred, stop the machine and have the generator and/ or load conditions checked for a generator or load fault that could cause excessive exciter field current to flow. Also have the system checked for loose or open connections to the voltage regulator sensing inputs. Any faults must be repaired. After repairs are complete, reset the voltage regulator by momentarily closing the Fault Reset contact or by cycling 24V control power. The generator may be restarted. If no generator or load fault has occurred and there are no loose or open connections to the sensing inputs of the voltage regulator, verify that the Over Excitation trip level and the delay settings are properly adjusted for the generator. Set the Over Excitation trip level slightly above the requirement of the application but not so high as to render the protection ineffective or damage the system. Reset the voltage regulator by momentarily closing the Fault Reset contact or by cycling 24V control power. The generator may be restarted. If an Over Excitation fault has not occurred, go to step 10.

**Note:** SR4 and SR4B generators may require up to 12 Amperes for full load excitation. A 10 second delay is needed in order to insure 300 percent short circuit current requirements.

10. If a Loss of Sensing fault has occurred, stop the machine and have the system checked for loose or open connections to the voltage sensing inputs of the voltage regulator. Also, have the generator and/ or load conditions checked for a generator or load fault that could cause the sensed voltage to be low. If the generator is equipped with voltage transformers for stepping the generator voltage down to levels usable by the voltage regulator, verify that the transformers are functional and that

any transformer fuses are not open. If transformer fuses are found to be open, replace the fuses. Any faults must be repaired. After repairs are complete, reset the voltage regulator by momentarily closing the Fault Reset contact or by cycling 24V control power. The generator may be restarted. If a Loss of Sensing fault has not occurred, go to step 11.

11. If a Field Overcurrent fault has occurred, stop the machine and have the generator and/ or load conditions checked for a generator or load fault that could cause excessive exciter field current to flow. Also have the system checked for loose or open connections to the voltage regulator sensing inputs. A Field Overcurrent fault is detected when output current from the voltage regulator exceeds approximately 28 A.

**OK** - If a Field Overcurrent fault has not occurred, go to step 12.

**NOT OK** - Any fault must be repaired. After repairs are complete, reset the voltage regulator by momentarily closing the Fault Reset contact or by cycling 24V control power. The generator may be restarted.

STOP.

12. If an Internal Memory Failure fault has occurred, try resetting the voltage regulator by momentarily closing the Fault Reset contact or by cycling 24V control power.

**STOP.** - If an Internal Memory fault has not occurred, go to step 13.

**NOT OK** - If after resetting the voltage regulator another Internal Memory Failure occurs, replace the voltage regulator.

STOP.

13. If an Internal Watchdog Failure fault has occurred, reset the voltage regulator by momentarily closing the Fault Reset contact or by cycling 24 volt control power.

**OK** - If an Internal Watchdog Failure fault has not occurred, go to step 14.

**NOT OK** - If after resetting the voltage regulator another Internal Watchdog Failure fault occurs, replace the voltage regulator.

STOP.

14. Replace the voltage regulator unit. If replacing the voltage regulator unit does not correct the problem, go to step 15.

15. There is a problem with the generator. Refer to the generator manual to troubleshoot the problem.

[Previous Screen](#)

< Product: NO EQUIPMENT SELECTED  
Model: NO EQUIPMENT SELECTED  
Configuration: NO EQUIPMENT SELECTED

## Testing and Adjusting

### Caterpillar Digital Voltage Regulator (CDVR)

Media Number -RENR7941-00

Publication Date -12/01/2003

Date Updated -12/19/2003

i01954791

## Low Voltage - Troubleshoot

SMCS - 4467-035



Illustration 1

g01021519

A black rectangular box containing a white warning symbol (exclamation mark in a triangle) followed by the word 'DANGER' in white, bold, uppercase letters.

**The Cat Digital Voltage Regulator presents an electrical shock/electrocution hazard. This hazard will cause serious injury or death.**

**Service by trained personnel only.**

**The terminals and heat sinks are live at hazardous voltages when power is applied and for up to 8 minutes after power is removed.**

---

1. Verify that the voltage adjustment is not set too low.

**OK** - If the voltage adjustment is correct, go to step 2.

**NOT OK** - If the voltage adjustment is too low, adjust the voltage to the correct setpoint.

STOP.

2. Verify that the underfrequency setpoint (knee frequency) is not greater than the generator frequency.

**OK** - If the underfrequency setpoint is correct, go to step 3.

**NOT OK** - If the underfrequency setpoint is too high, adjust the setpoint below the rated generator frequency.

STOP.

3. Verify that the generator is running at rated speed.

**OK** - If the generator is running at rated speed, go to step 5.

**NOT OK** - If the generator is not at rated speed, increase the generator speed to the rated level.

STOP.

4. PMG power or Shunt powered regulator

**PMG power** - Proceed to step5.

**Shunt powered** - Proceed to step6.

5. Check for the correct input power to the voltage regulator. Refer to Specification, "Electrical" for input power requirements.

**OK** - If the voltage is at the required level, go to step 7.

**NOT OK** - If the voltage regulator input voltage is low, refer to the generator manual for PMG repair.

STOP.

6. Verify that the potential transformer (if used) has the correct turns ratio and is supplying the correct voltage to the power input.

**OK** - If the turns ratio of the power potential transformer is correct, go to step 7.

**NOT OK** - If the turns ratio of the potential transformer is incorrect, is sized too small, or the transformer is not supplying the correct power, replace the potential transformer.

STOP.

7. Verify that the sensing potential transformer (if used) has the correct turns ratio and is operating correctly.

**OK** - If the sensing potential transformer is operating correctly, go to step 8.

**NOT OK** - If the turns ratio of the sensing potential transformer is incorrect, replace the sensing potential transformer.

STOP.

8. Low generator output voltage may occur when operating in droop mode with an inductive load. If the low voltage condition is not caused by the droop function, go to step 9.
9. Replace the voltage regulator.

[Previous Screen](#)

< Product: NO EQUIPMENT SELECTED  
Model: NO EQUIPMENT SELECTED  
Configuration: NO EQUIPMENT SELECTED

## Testing and Adjusting

### Caterpillar Digital Voltage Regulator (CDVR)

Media Number -RENR7941-00

Publication Date -12/01/2003

Date Updated -12/19/2003

i01954865

## High Voltage - Troubleshoot

SMCS - 4467-035

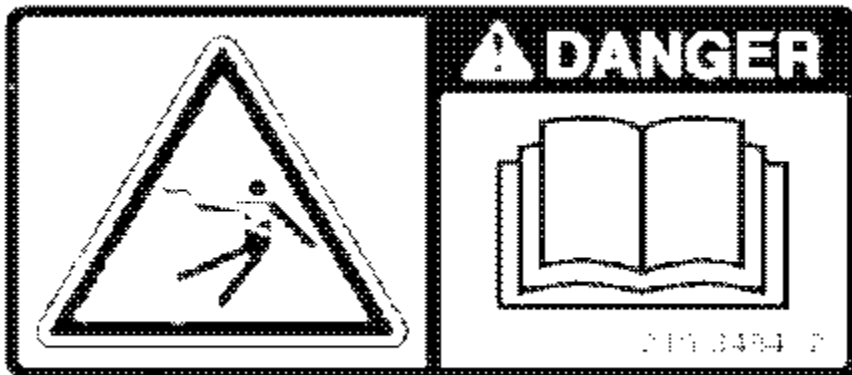

Illustration 1

g01021519

**The Cat Digital Voltage Regulator presents an electrical shock/electrocution hazard. This hazard will cause serious injury or death.**

**Service by trained personnel only.**

**The terminals and heat sinks are live at hazardous voltages when power is applied and for up to 8 minutes after power is removed.**

---

1. Verify that the voltage adjustment is not set too high.

**OK** - If the voltage adjustment is correct, go to step 2.

**NOT OK** - If the voltage adjustment is too high, adjust the voltage to the correct setpoint.

STOP.

2. Verify that the sensing potential transformer (if used) has the correct turns ratio.

**OK** - If the sensing potential transformer is correct, go to step 3.

**NOT OK** - If the turns ratio of the sensing potential transformer is incorrect, replace the sensing potential transformer with the correct one.

STOP.

3. High generator output voltage may occur when operating in droop mode with a capacitive load. If the high voltage condition is not caused by the droop function, go to step 4.

4. High generator output voltage may occur when operating in line drop compensation mode with a large generator load. If the high voltage condition is not caused by the line drop compensation function, go to step 5.

5. Verify that the fuses for the sensing potential transformer (if used) are not open.

**OK** - If the fuses for the sensing potential transformer are correct, go to step 6.

**NOT OK** - If the fuses for the sensing potential transformer are open, replace the fuses.

STOP.

6. Verify that the auxiliary input voltage going to the voltage regulator is present or abnormally high. Higher than normal voltage at this input will cause a higher than normal generator voltage. If voltage is present on the auxiliary input, remove the input by removing the wiring going to the voltage regulator. If the wire is removed and the generator voltage returns to the desired level, investigate where the voltage is coming from, possible a VAR/PF controller or another source of control. If the auxiliary input voltage is not present or abnormally high, go to step 7.

7. Replace the voltage regulator.

[Previous Screen](#)

< Product: NO EQUIPMENT SELECTED  
Model: NO EQUIPMENT SELECTED  
Configuration: NO EQUIPMENT SELECTED

## Testing and Adjusting

### Caterpillar Digital Voltage Regulator (CDVR)

Media Number -RENR7941-00

Publication Date -12/01/2003

Date Updated -12/19/2003

i01955489

## Unstable Voltage - Troubleshoot

SMCS - 4467-035

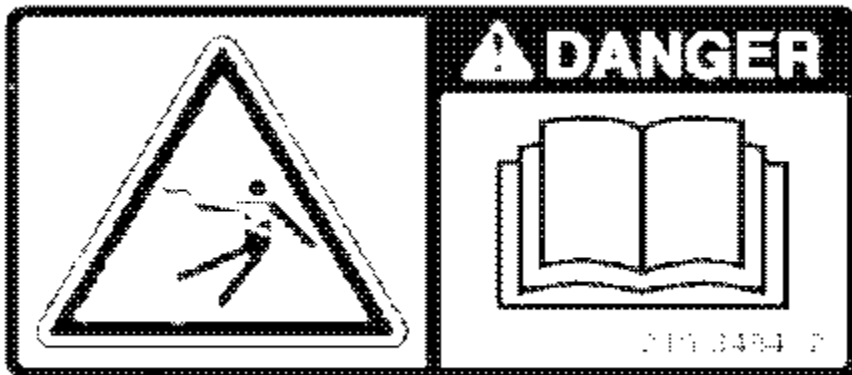

Illustration 1

g01021519

A black rectangular sign with a white exclamation mark inside a triangle on the left and the word "DANGER" in white, bold, sans-serif capital letters to its right.

**The Cat Digital Voltage Regulator presents an electrical shock/electrocution hazard. This hazard will cause serious injury or death.**

**Service by trained personnel only.**

**The terminals and heat sinks are live at hazardous voltages when power is applied and for up to 8 minutes after power is removed.**

---

1. Verify that the governor for the engine is operating properly.

**OK** - If the governor is operating properly, go to step 2.

**NOT OK** - If the governor is not operating properly, refer to the engine manual in order to troubleshoot the problem.

STOP.

2. Verify that the sensing and input power leads are connected securely.

**OK** - If the sensing or input power lead connections are secure, go to step 3.

**NOT OK** - If the sensing or input power leads are not connected securely, tighten the connections.

STOP.

3. Verify that the voltage regulator stability range is set to the proper range.

**OK** - If the stability range setting is correct, go to step 4.

**NOT OK** - If the stability range setting is incorrect, reset the stability range.

STOP.

4. Verify that the stability level is properly set. If the stability level is not properly set, reset the stability level.

[Previous Screen](#)

< Product: NO EQUIPMENT SELECTED  
Model: NO EQUIPMENT SELECTED  
Configuration: NO EQUIPMENT SELECTED

## Testing and Adjusting

### Caterpillar Digital Voltage Regulator (CDVR)

Media Number -RENR7941-00

Publication Date -12/01/2003

Date Updated -12/19/2003

i01955504

## Poor Voltage Regulation - Troubleshoot

SMCS - 4467-035

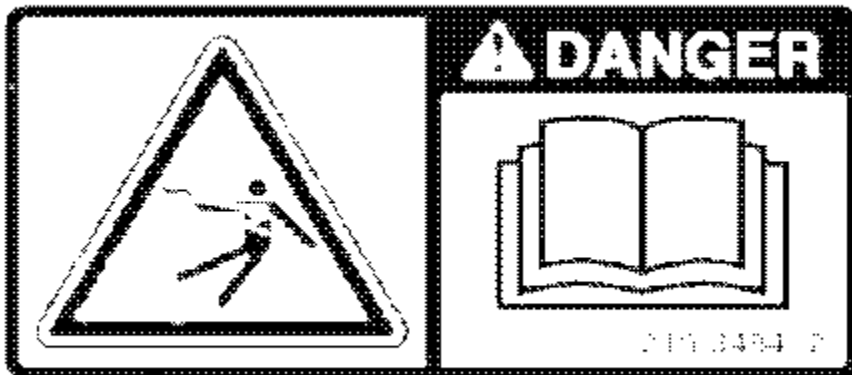

Illustration 1

g01021519

A black rectangular sign with a white exclamation mark inside a triangle on the left and the word "DANGER" in white, bold, sans-serif capital letters to its right.

**The Cat Digital Voltage Regulator presents an electrical shock/electrocution hazard. This hazard will cause serious injury or death.**

**Service by trained personnel only.**

**The terminals and heat sinks are live at hazardous voltages when power is applied and for up to 8 minutes after power is removed.**

---

1. Verify that the chassis of the voltage regulator is properly grounded.

**OK** - If the voltage regulator is properly grounded, go to step 2.

**NOT OK** - If the voltage regulator is not properly grounded, connect a dedicated ground wire to terminal P6-6 on the voltage regulator.

STOP.

2. Check for grounded field leads.

**OK** - If the field leads are not grounded, go to step 3.

**NOT OK** - If the field leads are grounded, isolate the field leads from ground.

STOP.

3. Check for grounded PMG leads.

**OK** - If the PMG leads are not grounded, go to step 4.

**NOT OK** - If the PMG leads are grounded, isolate the PMG leads from ground.

STOP.

4. Verify that the generator frequency is not dropping below the voltage regulator underfrequency setpoint when load is applied to the generator.

**OK** - If poor regulation is not related to voltage regulator underfrequency operation, go to step 5.

**NOT OK** - If the generator frequency is dropping below the underfrequency setpoint, reduce the setpoint if possible. Also check the engine and generator for proper sizing in relation to the applied load.

STOP.

**Note:** Measure the PMG voltage from line to line.

5. Verify that regulation is not being affected by normal droop operation. If droop operation is not affecting regulation, go to step 6.
6. Verify that regulation is not being affected by normal line loss compensation. If line loss compensation is not affecting regulation, replace the voltage regulator.

On new applications and when commissioning, check the PID value. If voltage fluctuates at steady-state

N.L. or F.L., reduce  $K_g$  or if at 1.0 reduce  $K_p$ . Recalculate PID in calculator.

**Note:** Self Excited (shunt powered) generators will have a greater input power voltage than PMG generators. This will require a lower gain settings ( $K_g$  first then  $K_p$  if necessary) on comparably sized machine. Adjust  $K_g$  values first, then  $K_p$  values to reach acceptable steady-state and transient responses.

---

Copyright 1993 - 2005 Caterpillar Inc.  
All Rights Reserved.  
Private Network For SIS Licensees.

Mon Feb 14 08:28:14 EST 2005

[Previous Screen](#)

< Product: NO EQUIPMENT SELECTED  
Model: NO EQUIPMENT SELECTED  
Configuration: NO EQUIPMENT SELECTED

## Testing and Adjusting

### Caterpillar Digital Voltage Regulator (CDVR)

Media Number -RENR7941-00

Publication Date -12/01/2003

Date Updated -12/19/2003

i01955501

## No Line Loss Compensation - Troubleshoot

SMCS - 4467-035

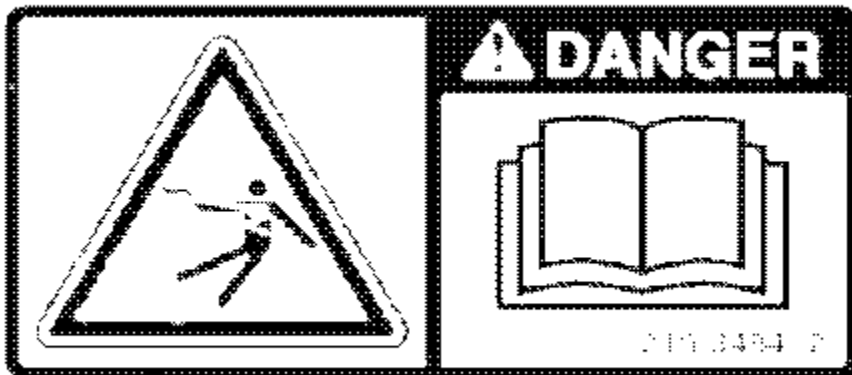

Illustration 1

g01021519

A black rectangular warning sign with a white exclamation mark inside a triangle and the word 'DANGER' in white capital letters.

**The Cat Digital Voltage Regulator presents an electrical shock/electrocution hazard. This hazard will cause serious injury or death.**

**Service by trained personnel only.**

**The terminals and heat sinks are live at hazardous voltages when power is applied and for up to 8 minutes after power is removed.**

---

1. Verify that the voltage regulator is programmed for line loss compensation. If the voltage regulator is programmed for line loss compensation, go to step 2.
2. Verify that the voltage regulator line drop setting is not adjusted to 0%. If the line drop setting is adjusted to 0%, increase the setpoint above 0%. If the line drop setting is adjusted to above 0%, go to step 3.
3. Check for an open in the circuit connected to voltage regulator terminals P12-1 and P12-2 and CT2. If there is an open circuit, repair as necessary. If there is not an open circuit, go to step 4.
4. Verify that all connections are correct according to Testing and Adjusting, "Wiring Diagrams". If connections are incorrect, correct the problem. If connections are correct, go to step 5.
5. Verify that the load that is being applied to the generator for droop testing is not a purely resistive load. If only a resistive load is being applied to the generator, apply an inductive load and retest. If the load being applied to the generator is inductive, go to step 6.
6. Verify that the current sensing transformer that is being used is compatible with the voltage regulator. For example, a current sensing transformer with a 1-ampere output rating would produce very little droop since the voltage regulator has a 5-ampere current transformer input. If the current transformer input is incorrect, replace the current sensing transformer for compatibility. If the current transformer input is correct, go to step 7.
7. If all of the previous steps fail to correct the malfunction, replace the voltage regulator.

[Previous Screen](#)

< Product: NO EQUIPMENT SELECTED  
Model: NO EQUIPMENT SELECTED  
Configuration: NO EQUIPMENT SELECTED

## Testing and Adjusting

### Caterpillar Digital Voltage Regulator (CDVR)

Media Number -RENR7941-00

Publication Date -12/01/2003

Date Updated -12/19/2003

i01955495

## No Voltage Drop - Troubleshoot

SMCS - 4467-035

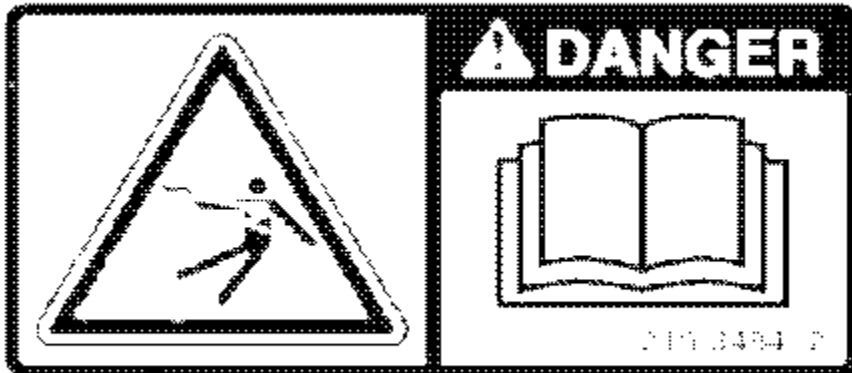

Illustration 1

g01021519

A black rectangular warning sign with a white exclamation mark inside a triangle and the word 'DANGER' in white capital letters.

**The Cat Digital Voltage Regulator presents an electrical shock/electrocution hazard. This hazard will cause serious injury or death.**

**Service by trained personnel only.**

**The terminals and heat sinks are live at hazardous voltages when power is applied and for up to 8 minutes after power is removed.**

---

1. Verify that the voltage regulator is programmed for droop mode. If the voltage regulator is programmed for droop mode, go to step 2.
2. Verify that the voltage regulator droop setting is not adjusted to 0% droop. If the droop setting is adjusted to 0% droop, increase the setpoint above 0%. If the droop setting is adjusted to above 0%, go to step 3.
3. Check for an open in the circuit connected to voltage regulator terminals P12-1 and P12-2 and CT2. If there is an open circuit, repair as necessary. If there is not an open circuit, go to step 4.
4. Verify that all connections are correct according to Testing and Adjusting, "Wiring Diagrams". If connections are incorrect, correct the problem. If connections are correct, go to step 5.
5. Verify that the load that is being applied to the generator for droop testing is not a purely resistive load. If only a resistive load is being applied to the generator, apply an inductive load and retest. If the load being applied to the generator is inductive, go to step 6.
6. Verify that the current sensing transformer that is being used is compatible with the voltage regulator. For example, a current sensing transformer with a 1-ampere output rating would produce very little droop since the voltage regulator has a 5-ampere current transformer input. If the current transformer input is incorrect, replace the current sensing transformer for compatibility. If the current transformer input is correct, go to step 7.
7. If all of the previous steps fail to correct the malfunction, replace the voltage regulator.

[Previous Screen](#)

< Product: NO EQUIPMENT SELECTED  
 Model: NO EQUIPMENT SELECTED  
 Configuration: NO EQUIPMENT SELECTED

## Testing and Adjusting

### Caterpillar Digital Voltage Regulator (CDVR)

Media Number -RENR7941-00

Publication Date -12/01/2003

Date Updated -12/19/2003

i01951525

## Wiring Diagrams

SMCS - 4467; 7566

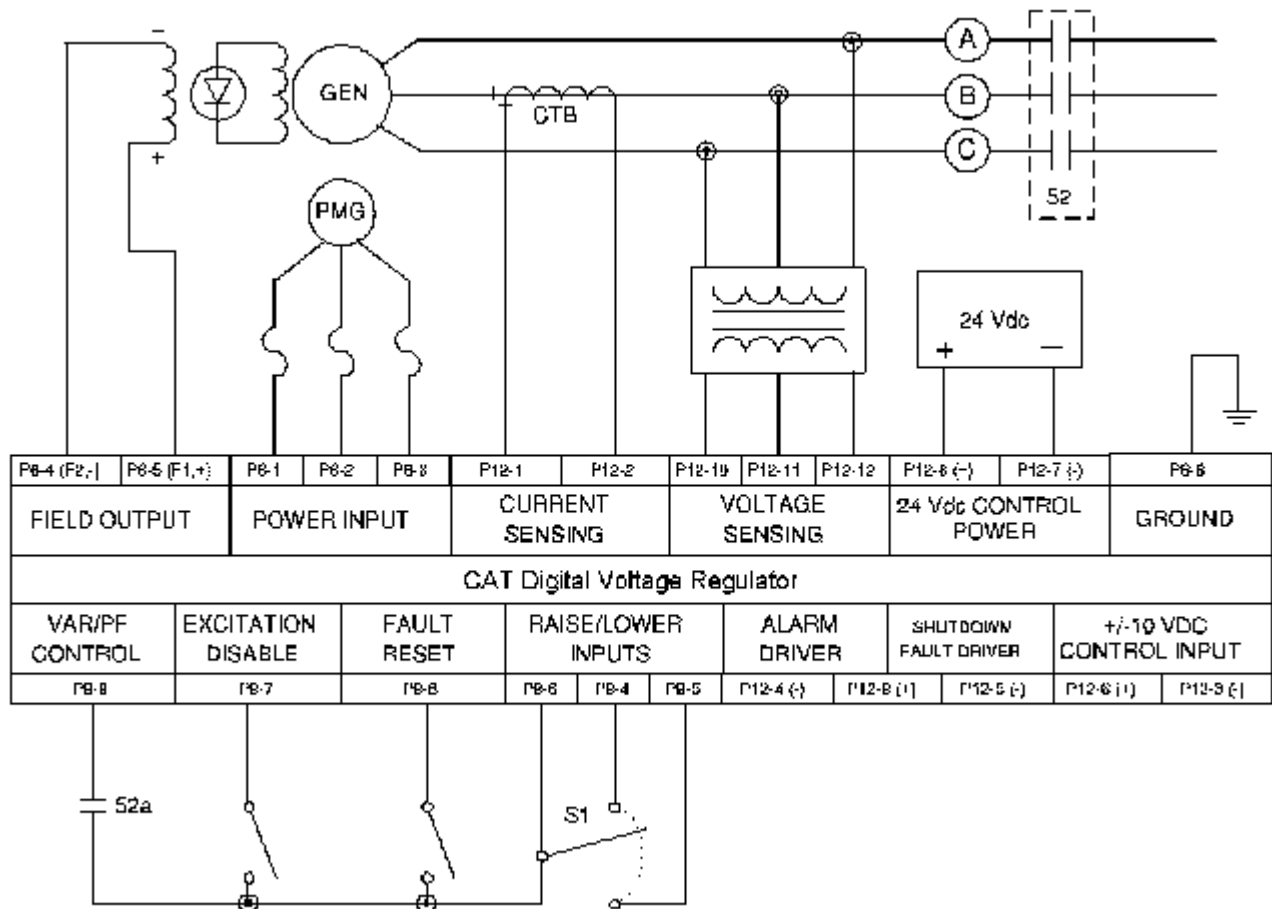

Illustration 1

g010

Typical connections for PMG power, ABC rotation, and three-phase sensing

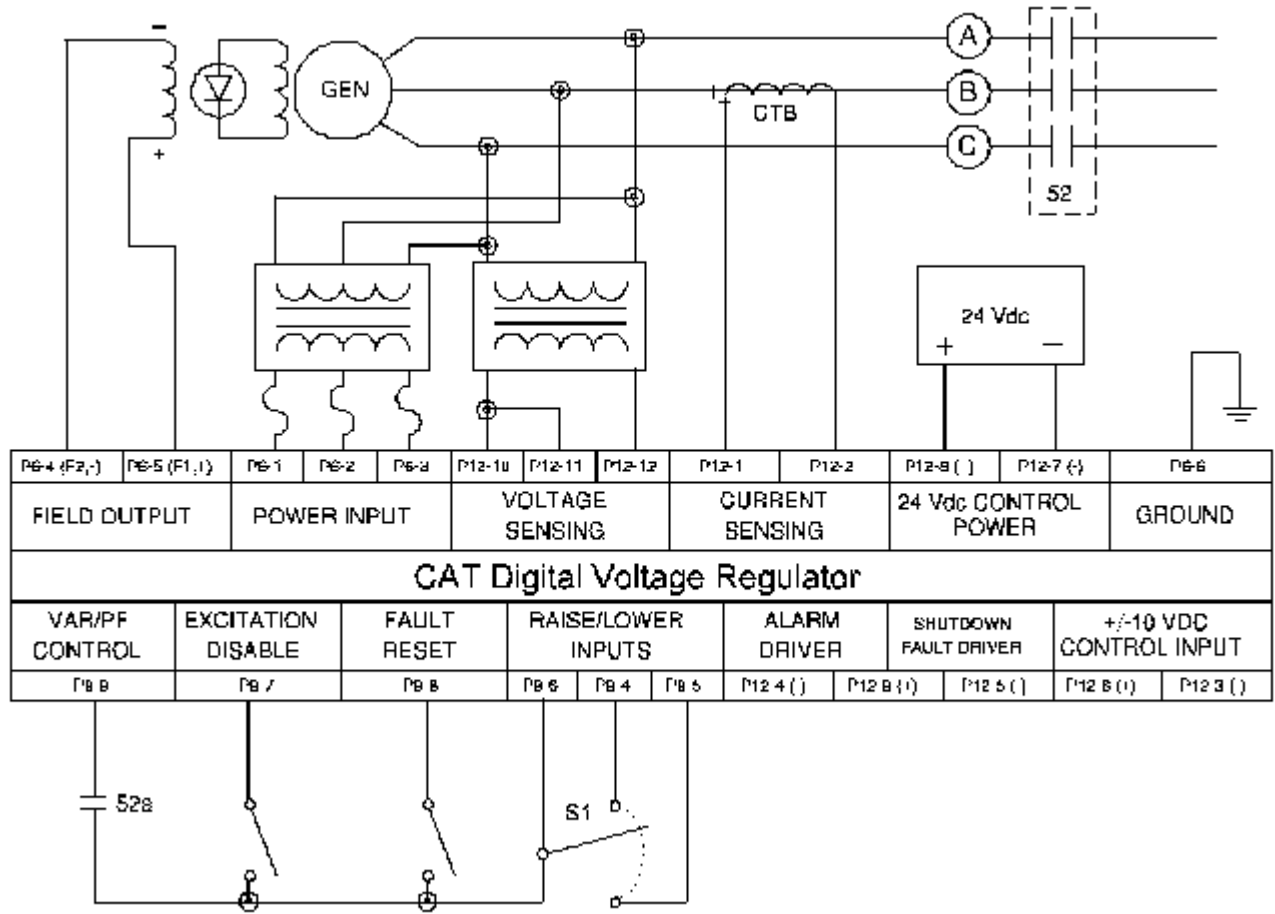

Illustration 2

g010

Typical connections for Shunt power, ABC rotation, and single-phase sensing

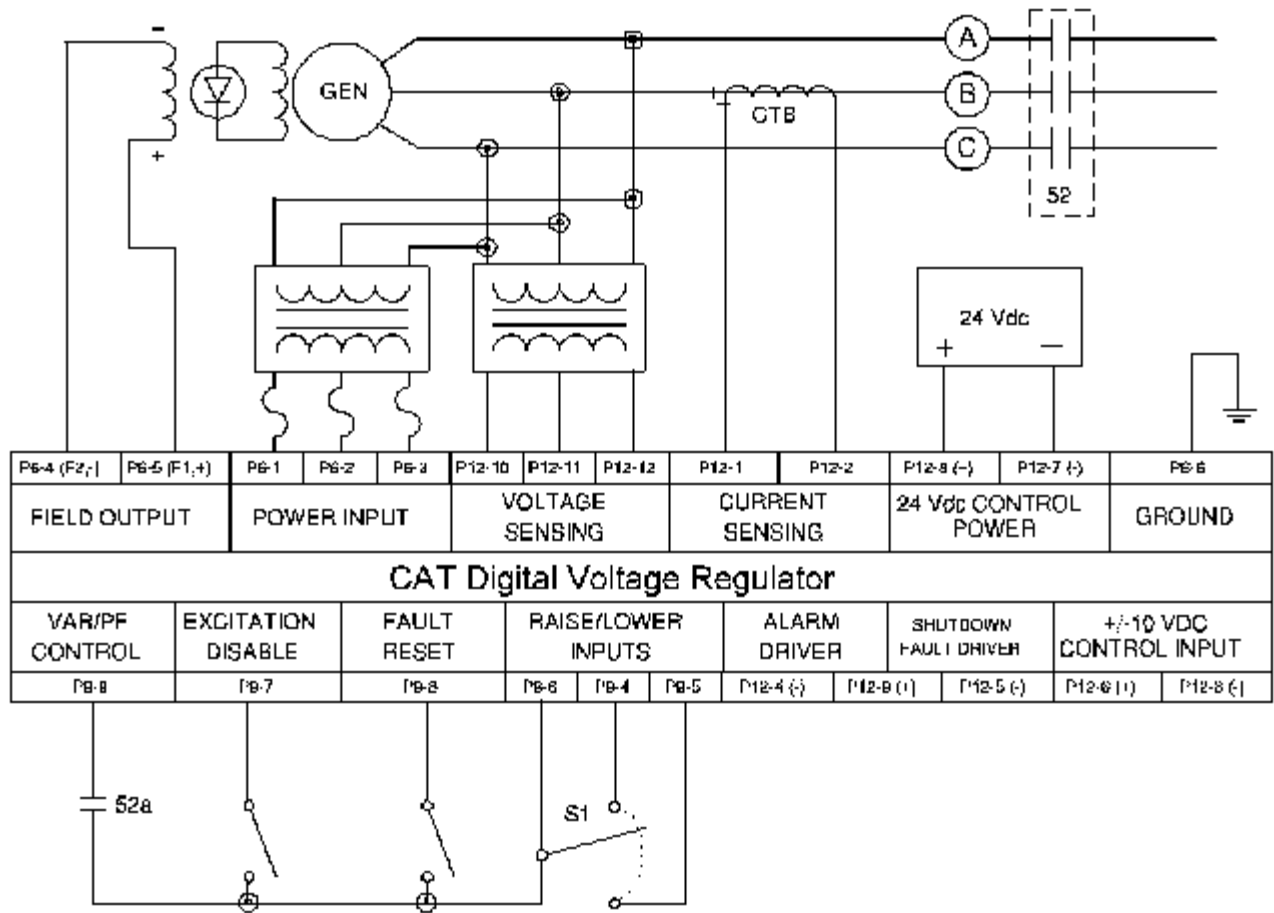

Illustration 3

g010

Typical connections for Shunt power, ABC rotation, and three-phase sensing

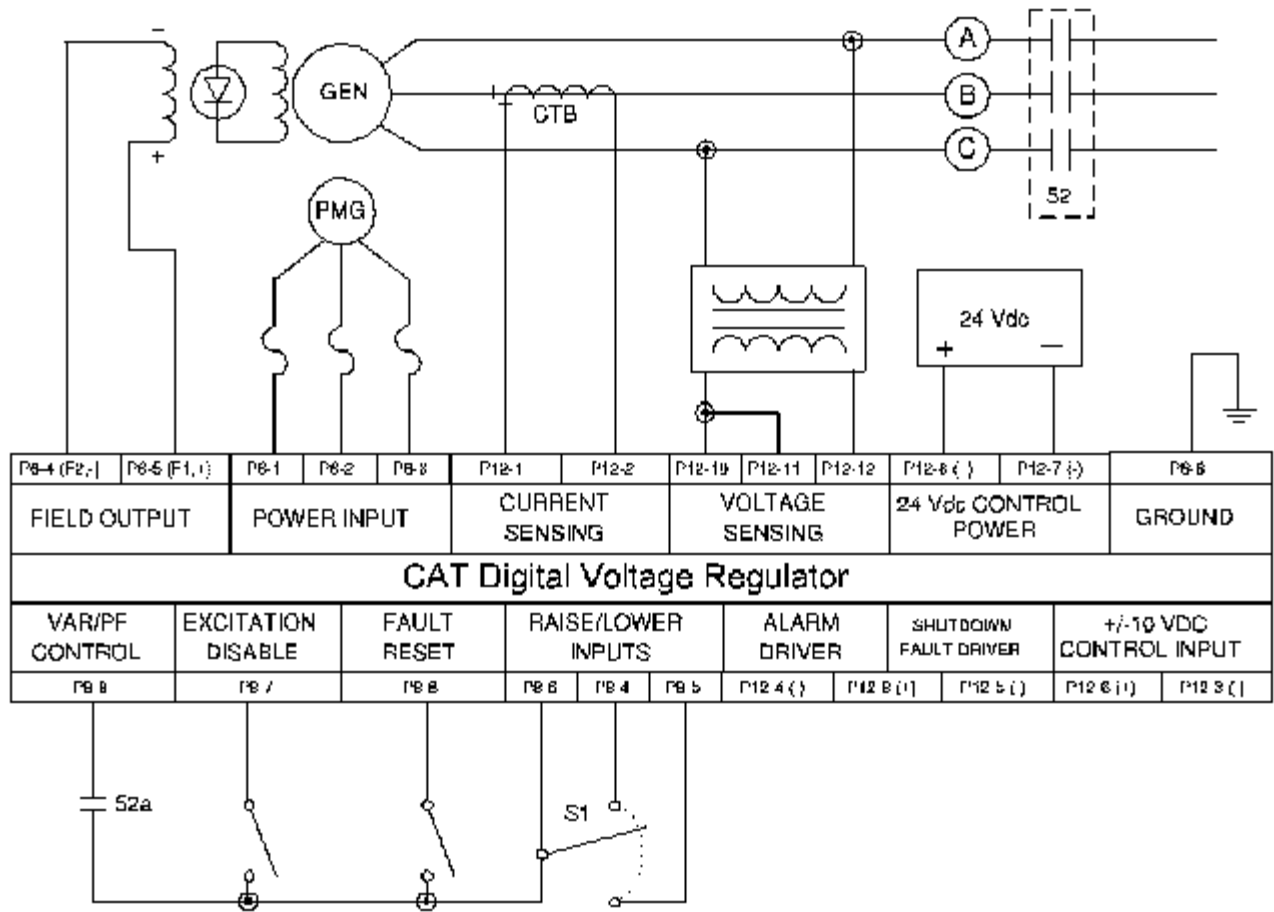

Illustration 4

g010

Typical connections for PMG power, ABC rotation, and single-phase sensing

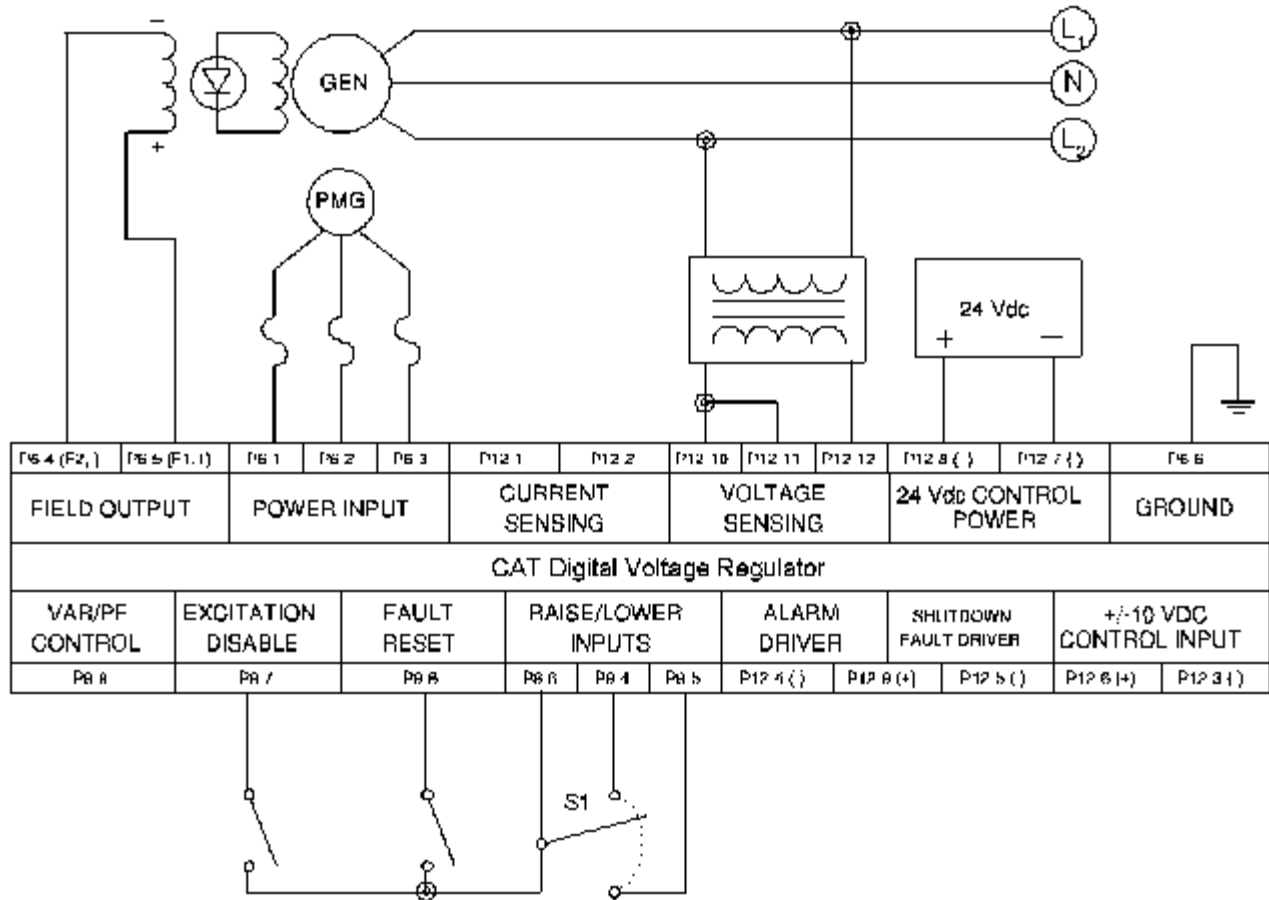

Illustration 5  
 Typical connections for a PMG Power Input and a single-phase generator

g010

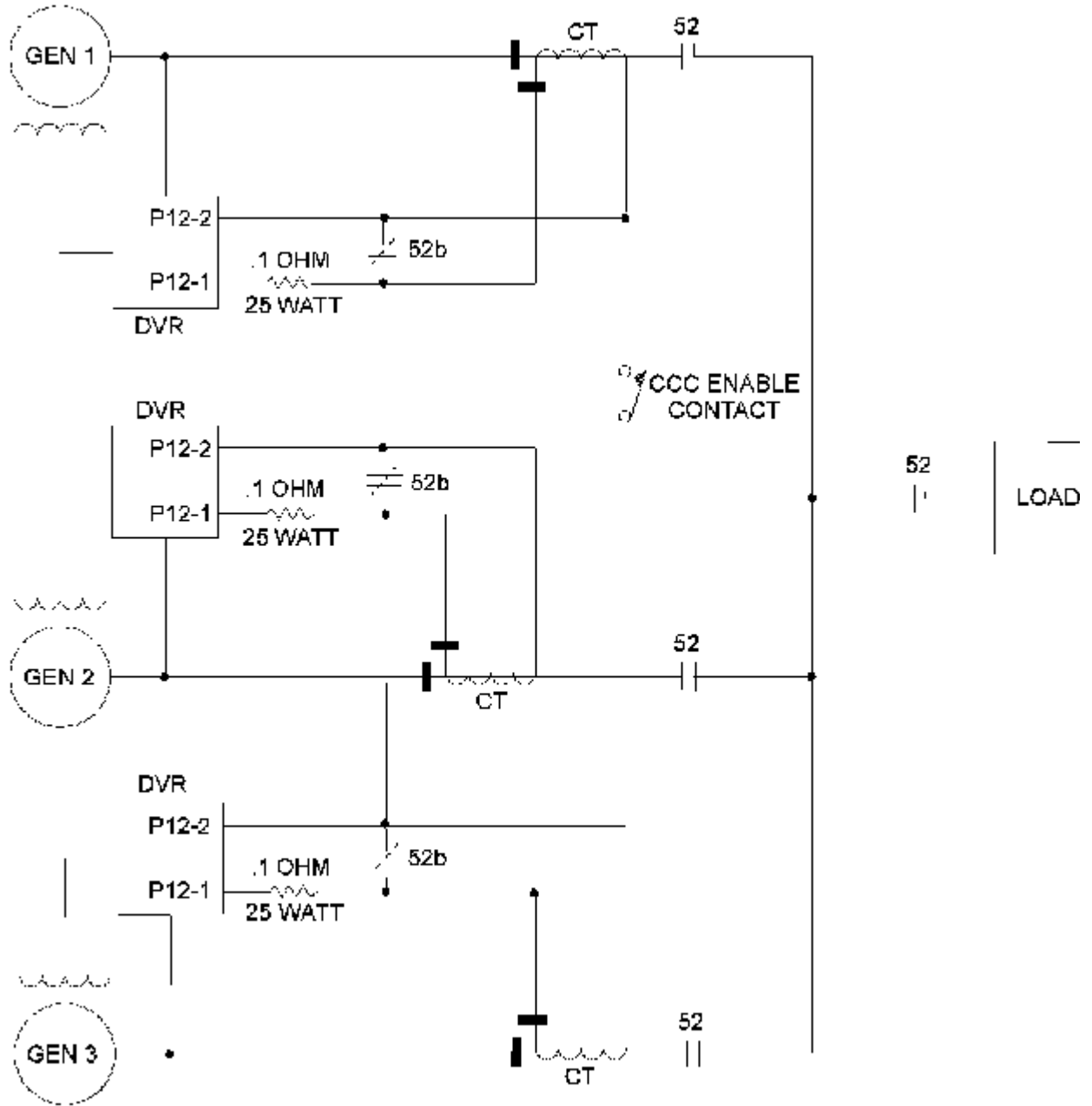

Illustration 6  
Cross current compensation

g010