



Specifications Systems Operation Testing and Adjusting

Caterpillar Digital Voltage Regulator (CDVR)



Important Safety Information

Most accidents that involve product operation, maintenance and repair are caused by failure to observe basic safety rules or precautions. An accident can often be avoided by recognizing potentially hazardous situations before an accident occurs. A person must be alert to potential hazards. This person should also have the necessary training, skills and tools to perform these functions properly.

Improper operation, lubrication, maintenance or repair of this product can be dangerous and could result in injury or death.

Do not operate or perform any lubrication, maintenance or repair on this product, until you have read and understood the operation, lubrication, maintenance and repair information.

Safety precautions and warnings are provided in this manual and on the product. If these hazard warnings are not heeded, bodily injury or death could occur to you or to other persons.

The hazards are identified by the "Safety Alert Symbol" and followed by a "Signal Word" such as "DANGER", "WARNING" or "CAUTION". The Safety Alert "WARNING" label is shown below.



The meaning of this safety alert symbol is as follows:

Attention! Become Alert! Your Safety is Involved.

The message that appears under the warning explains the hazard and can be either written or pictorially presented.

Operations that may cause product damage are identified by "NOTICE" labels on the product and in this publication.

Caterpillar cannot anticipate every possible circumstance that might involve a potential hazard. The warnings in this publication and on the product are, therefore, not all inclusive. If a tool, procedure, work method or operating technique that is not specifically recommended by Caterpillar is used, you must satisfy yourself that it is safe for you and for others. You should also ensure that the product will not be damaged or be made unsafe by the operation, lubrication, maintenance or repair procedures that you choose.

The information, specifications, and illustrations in this publication are on the basis of information that was available at the time that the publication was written. The specifications, torques, pressures, measurements, adjustments, illustrations, and other items can change at any time. These changes can affect the service that is given to the product. Obtain the complete and most current information before you start any job. Caterpillar dealers have the most current information available.



When replacement parts are required for this product Caterpillar recommends using Caterpillar replacement parts or parts with equivalent specifications including, but not limited to, physical dimensions, type, strength and material.

Failure to heed this warning can lead to premature failures, product damage, personal injury or death.

Table of Contents

Specifications Section

Electrical	4
Dimensions	7

Systems Operation Section

General Information	8
Startup Profile Function	10
Loading and Stopping Profile	11
Voltage Regulation	12
Line Loss Compensation	12
Reactive Voltage Droop	13
Cross Current Compensation	14
KVAR Regulation	14
Power Factor Regulation	15
Parameters	16
Remote Communication	17

Testing and Adjusting Section

Testing and Adjusting

General Information	20
Service Tools	20
Startup Procedure	21
Parameter Viewing and Configuration (Caterpillar PC Software)	23
Parameter Viewing and Configuration (Caterpillar Electronic Technician)	57
Gain Setting - Adjust	61
Troubleshooting	62
No Voltage - Troubleshoot	62
Low Voltage - Troubleshoot	65
High Voltage - Troubleshoot	66
Unstable Voltage - Troubleshoot	66
Generator Overcurrent - Troubleshoot	67
Reverse VAR Condition - Troubleshoot	68
Poor Voltage Regulation - Troubleshoot	68
No Line Loss Compensation - Troubleshoot	69
No Voltage Droop - Troubleshoot	70
Wiring Diagrams	71

Index Section

Index	85
-------------	----

Specifications Section

i02786621

Electrical

SMCS Code: 4467

Table 1

Specifications	
Regulation	0.25% from no load to full load.
Regulator temperature drift	Less than $\pm 1\%$ for any 40 °C (72 °F) change over the ambient operating temperature range.
Configurable Volts/Hz characteristic	Two slope ranges adjustable from 1 to 10 V/Hz. See the Regulation Characteristic Illustration.
Regulator response time	Maximum of 10 milliseconds.
Regulator sensing	True RMS 3-phase sensing is standard. Single phase sensing is available. Variable sense range: 90 to 600 volts.
Regulator stability	The regulator maintains stable output voltage within 0.25% for total harmonic distortion of the generator output voltage waveform up to 30%, and within 0.50% for total harmonic distortion of the generator output voltage waveform up to 40%. These values are based on a typical 6 SCR bridge.
Telephone influence factor (TIF)	Less than 50. Complies with MIL STD 461C Part 9 and VDE 0875 level N.
Fine voltage adjust range	$\pm 10\%$ of regulator sensing voltage.
Regulator voltage gain (Line loss compensation)	Adjustable from 0 to 10%.
Fault detection and identification	Diagnostics identify operation outside of programmed limits. Specific fault information is available even after the unit has been powered down. CANBUS only.
Harmonic tolerance	For total harmonic distortion of the generator output voltage waveform up to 30%, the regulator maintains stable output voltage within 0.25%. For total harmonic distortion of the generator output voltage waveform up to 40%, the regulator maintains stable output voltage within 0.50%. These values are based on a typical 6 SCR bridge.
Reactive droop adjustment	Adjustable from 0 to 10%.
Overexcitation protection	Shuts off generator output when excitation current exceeds normal operating currents for 10 seconds or instantaneous shutoff if output current exceeds approximately 28 Amperes.
Ambient operating temperature	-40 °C (-40 °F) to +70 °C (+ 158 °F).
Storage temperature range	-40 °C (-40 °F) to +85 °C (+ 185 °F).
Power dissipation	5 watts at idle, 55 watts at rated output.
Shock	Withstands up to 20 g's in three mutually perpendicular planes .
Vibration	Withstands 4.5 g's at frequencies between 18 and 2000 Hz in three mutually perpendicular planes.
Salt fog	5% salt spray for 48 hours at 38 °C (100.4 °F) at 115% of the nominal operating voltage.
Weight	1.47 kg (3.24 lb.).
Electromagnetic compatibility	Meets 89/336/EEC Electromagnetic Compatibility Directive.
Power supply	24 \pm 6 volt DC power supply required (0.5 amp).

(continued)

(Table 1, contd)

Specifications		
Conformity	UL	UL Recognized per Standard 508, UL File No. E97035.
	CSA	Certified per Standard CAN/CSA-C22.2 No. 14-95, CSA Dile No. LR 23131.
	CE	Conforms to the following standards: Radiated Emissions EN50081-2, Radiated Immunity (electric field) EN61000-4-3 (10 V/m), Radiated Immunity (conducted) EN61000-4-6 (10 VRMS), Conducted Emissions EN50081-2 (EN55011, Class A), ESD Immunity EN50082-2 (4 KV contact, 8 KV air), EFT Immunity EN50082-2 (2 KV coupling clamp), Magnetic Immunity EN50082-2 (30ARMS, 50 Hz), Safety EN61010-1.

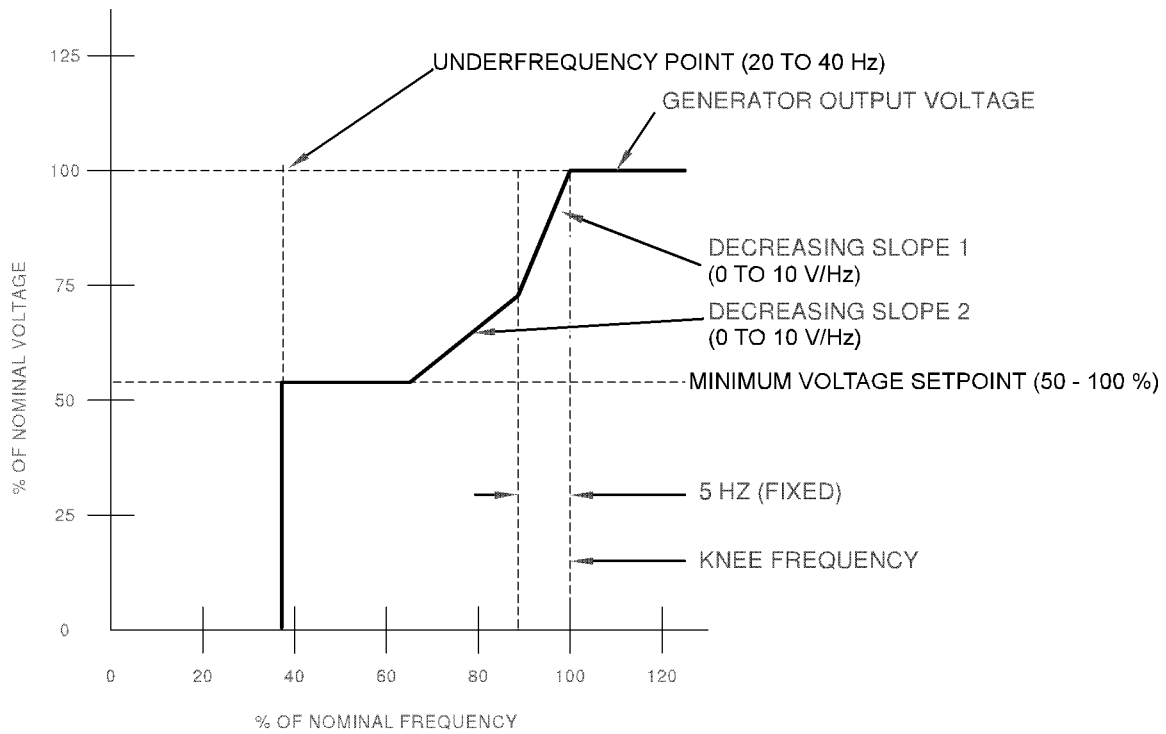

Illustration 1
Regulation Characteristic

g01040043

Table 2

Summary of Operating Parameters				
Parameter	Specifications			
Voltage Regulation Rating	120 to 15000 Volts			
Generator Type	PM SE AREP			
Power Input	Voltage ⁽¹⁾	Frequency	Burden (Continuous)	
	80 to 264 Volts (3Ø) 100 to 280 Volts (1Ø)	50 to 400 Hz	1150 VA (63 VDC applications) or 1900 VA (125 VDC applications)	
Output Rating	Maximum Continuous		Maximum Forcing (10 Seconds)	
	Voltage	Current	Voltage	Current
	63 or 125 Volts	12 or 10 Amperes	125 or 250 Volts	25 or 20 Amperes
Sensing	Voltage		Maximum VA Burden per Ø	
	90 to 600 Volts		1 VA	
Reactive Droop	Maximum Current		Maximum VA Burden	
	5 Amperes		1 VA	
Exciter Field Resistance	Minimum Resistance		Maximum Resistance	
	3 Ohms		39 Ohms	

⁽¹⁾ As the CDVR input voltage increases, the PWM duty cycle decreases. As PWM duty cycle decreases, system stability may decrease as well. Powering the CDVR with a voltage closer to the low end of this range is preferred.

i02852265

Dimensions

SMCS Code: 4467

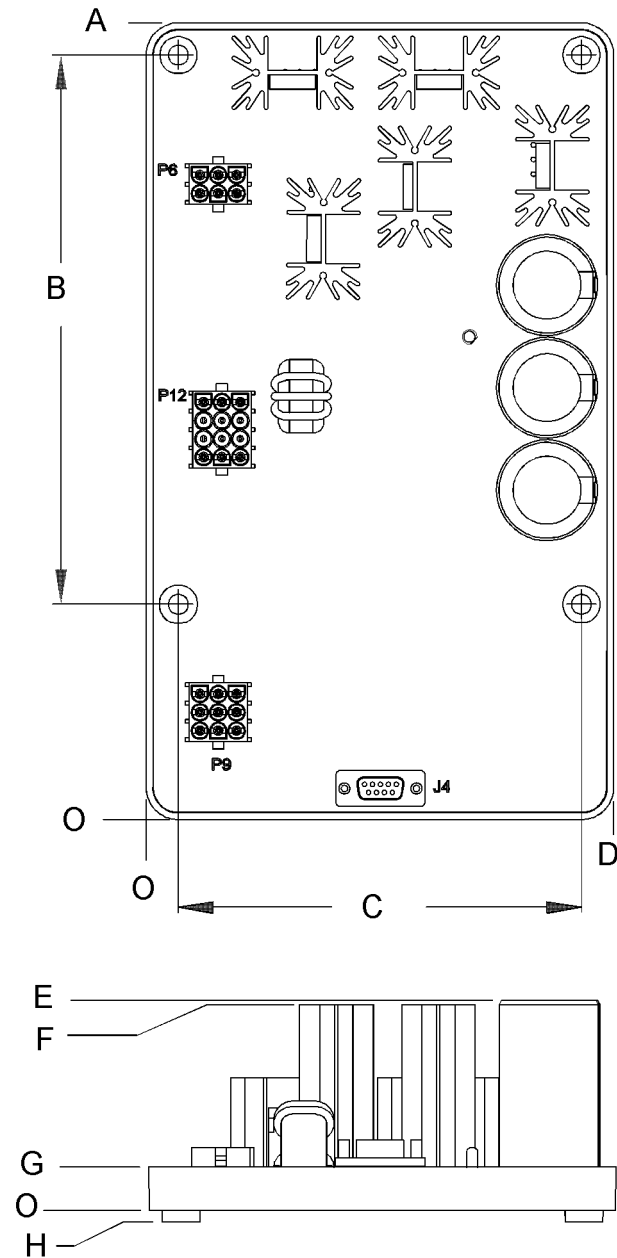

Illustration 2

g01415745

Dimensions of the Caterpillar Digital Voltage Regulator

- (A) 276.4 mm (10.88 inch)
- (B) 190.5 mm (7.50 inch)
- (C) 139.7 mm (5.50 inch)
- (D) 162.1 mm (6.38 inch)
- (E) 72.9 mm (2.87 inch)
- (F) 71.4 mm (2.81 inch)
- (G) 15.0 mm (0.59 inch)
- (H) 4.06 mm (0.16 inch)

Systems Operation Section

i02787221

General Information

SMCS Code: 4467

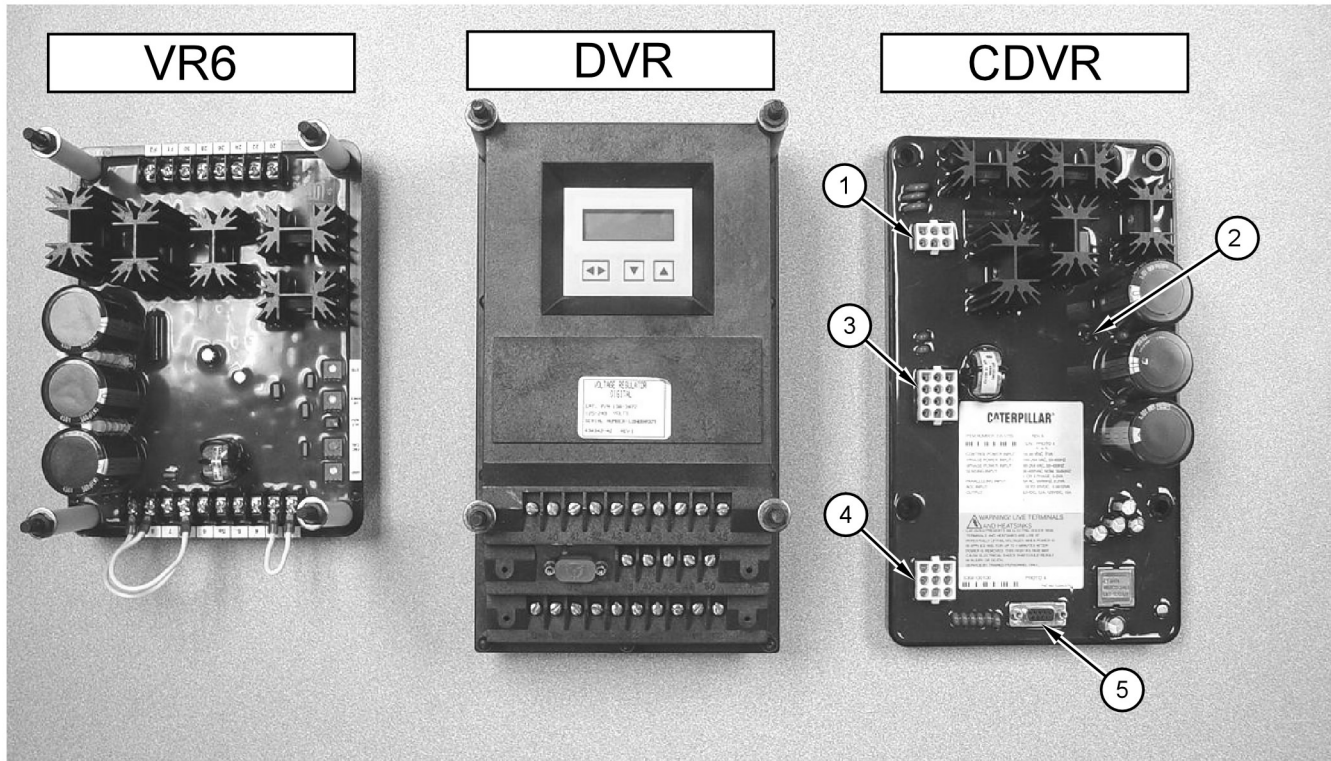

Illustration 3

g01118951

(1) "P6" Connector
(2) LED Indicator

(3) "P12" Connector
(4) "P9" Connector

(5) "J4" Connector

The Caterpillar Digital Voltage Regulator (CDVR) is a microprocessor based voltage regulator. The main purpose of a digital voltage regulator is to regulate the output voltage of a generator that is used with an engine generator set. Control power for the Digital Voltage Regulator is supplied from an external 24 DCV source. The power stage of the Digital Voltage Regulator can be supplied from a multi-pole, high frequency, permanent magnet generator (PMG), from the generator output (shunt excitation), or from auxiliary windings that are included on some generators. Connections to the Digital Voltage Regulator are made through three multi-pin, plug type connectors. The communication between the Digital Voltage Regulator and a service tool is accomplished using a CANBUS protocol.

The Caterpillar Digital Voltage Regulator has three multiple-pin, plug-type connectors. These connectors are labeled "P6", "P9", and "P12". See illustration 3.

Connector "P6" is a six-pin header that mates with a six-pin connector. Connector "P9" is a nine-pin header that mates with a nine pin connector. Connector "P12" is a twelve pin header that mates with a twelve pin connector.

The regulator has a nine pin D sub connector that is labeled "J4". This connector is used for interface with IBM compatible personal computers.

Note: The Caterpillar Digital Voltage Regulator should be hard wired to earth ground with at least a 16 AWG copper wire that is attached to the ground terminal "P6-6".

Note: When the unit is configured in a system with other devices, a separate lead should be used to ground the bus from each device.

Note: When the digital voltage regulator is installed remotely from the generator, special care should be given during installation to ensure proper engineering procedures are followed to prevent electromagnetic noise from reducing the performance of the regulator or other system components.

Note: When mounting the regulator remotely, the sensing wires, PMG wires, and exciter field wires should each be routed in their own separate tray or conduit. The optional customer wiring should be separated from all other signals in a control wiring conduit. The voltage sensing wires must be twisted together. The exciter field wires must also be twisted together.

Connectors

Connector “P6”

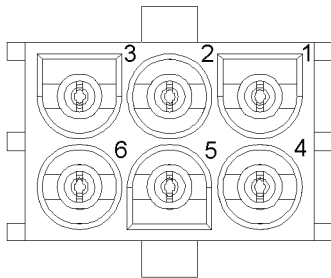

Illustration 4 g01013614
Pin out for the “P6” Connector on the CDVR

Table 3

P6 Terminal Functions	
Terminal	Function
P6-1	Power Input (single phase)
P6-2	Power Input (single phase)
P6-3	Power Input
P6-4	F-
P6-5	F+
P6-6	Chassis Ground

Connector “P9”

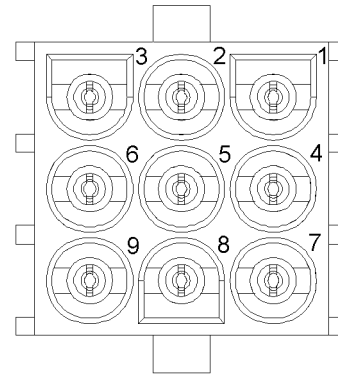

Illustration 5 g01013761
Pin out for the “P9” Connector on the CDVR

Table 4

P9 Terminal Functions	
Terminal	Function
P9-1	CANbus - High
P9-2	CANbus - Low
P9-3	CANbus - Drain (Shield)
P9-4	Contact Sense - Lower
P9-5	Contact Sense - Raise
P9-6	Contact Sense - Common
P9-7	Contact Sense - Excitation Disable
P9-8	Contact Sense - Fault Reset
P9-9	Contact Sense - Var/PF Enable

Connector “P12”

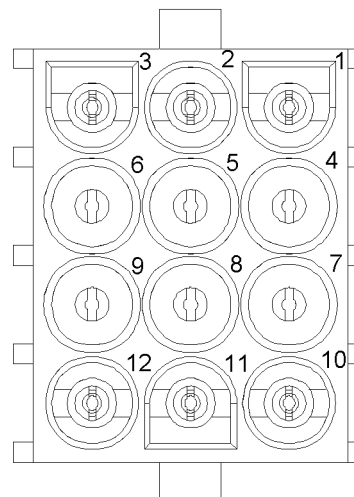

Illustration 6 g01013628
Pin out for the “P12” Connector on the CDVR

Table 5

i02848546

P12 Terminal Functions	
Terminal	Function
P12-1	B-phase generator current sensing (CT1)
P12-2	B-phase generator current sensing (CT2)
P12-3	±10 DCV Input (B), -
P12-4	Alarm Output Driver (24V, 100mA)
P12-5	Fault Shutdown Driver (24V, 100mA)
P12-6	±10 DCV Input (A), +
P12-7	18 to 30 V Control Power Input (B-)
P12-8	18 to 30 V Control Power Input (B+)
P12-9	Driver Supply (50) (24V, 100mA)
P12-10	Generator Voltage Sensing - C (T3), lead 20 for SR4 and SR4B generators) ⁽¹⁾
P12-11	Generator Voltage Sensing - B (T2), lead 24 for SR4 and SR4B generators) ⁽¹⁾
P12-12	Generator Voltage Sensing - A (T1), lead 22 for SR4 and SR4B generators) ⁽¹⁾

⁽¹⁾ Refer to the generator set wiring diagrams.

The Caterpillar Digital Voltage Regulator has the following features:

- Three control modes:
 1. Automatic voltage regulation (AVR)
 2. Power factor (PF) regulation
 3. Reactive power (VAR) regulation
- Programmable stability settings
- Soft start control with an adjustable time setting in AVR mode
- Dual slope voltage versus frequency (V/Hz) characteristic
- Three-phase or single-phase voltage sensing
- Single-phase current sensing
- Field current and field voltage sensing
- Ten protection functions

Startup Profile Function

SMCS Code: 4467

The parameters that are related to the startup profile function are listed below.

- Generator Rated Voltage
- Knee Frequency
- Underfrequency Point

The digital voltage regulator will begin to build voltage following the “Soft Start” settings before the configurable underfrequency point has been reached. After the configurable underfrequency point has been reached, the digital voltage regulator will begin to build voltage following a volts per hertz profile. When the speed reaches the knee frequency point, the loading/stopping profile takes effect. The startup profile function will not be initiated again unless the frequency drops below the underfrequency point. The underfrequency point is defaulted to 25 Hz, with a range of 20 to 40 Hz. This is the same underfrequency set point that is used by the loading and stopping set point. The knee frequency point is the point at which the digital voltage regulator will regulate to the voltage specified by the generator output voltage parameter.

i02847653

Loading and Stopping Profile

SMCS Code: 4467

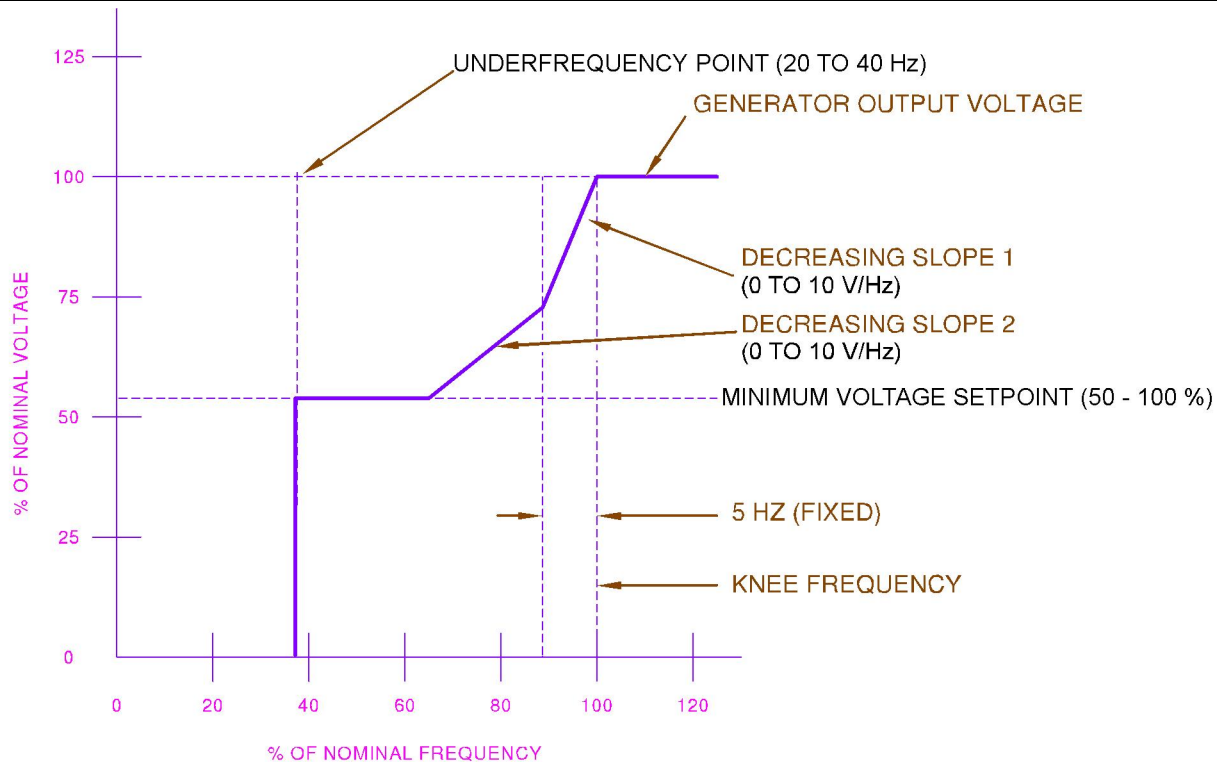

Illustration 7

g01012488

The parameters that are related to the loading and stopping profile are listed below.

- Generator Output Voltage
- Knee Frequency
- Decreasing V/Hz Slope 1
- Decreasing V/Hz Slope 2
- Minimum Voltage
- Underfrequency Point

Voltage regulators are generally of the volts per hertz type or the constant voltage type. The digital voltage regulator can perform as a constant voltage regulator or a volts per hertz type regulator depending on user configuration. Volts per hertz type regulators are commonly used with reciprocating internal combustion engine driven generator sets because they provide an automatic means for the engine to recover from a large block load. In the digital voltage regulator, the block load recovery performance is configurable so that it may be field optimized for each specific application.

When the generator is running and if a large load is applied, the frequency and voltage will drop. The loading/stopping function minimizes the amount of time that it takes the engine and generator to recover and increases the ability to pick up large loads.

As a large load is applied, the engine speed will begin to drop (frequency decreases). As the frequency decreases below the knee frequency, the voltage reference will decrease on a Volts/Hz slope according to the decreasing slope 1 value. If the frequency decrease continues beyond the knee frequency minus 5 Hz, then the voltage reference will decrease on a Volts/Hz slope according to the decreasing slope 2 value until the minimum voltage level is reached. The digital voltage regulator will try to regulate the generator output voltage at the minimum voltage, unless the underfrequency point is reached where the generator output voltage will decrease to a minimum value.

As the engine recovers from the load increase, the voltage will increase in the reverse order as it decreased, unless the frequency dropped below the underfrequency point. If the frequency dropped below the underfrequency point, the startup profile will be used for the recovery.

In some applications it is desirable to maintain a constant voltage at the possible sacrifice of a larger frequency dip during load transients. The digital voltage regulator can accommodate these applications if the knee frequency is configured for a lower value than normal. The actual value will depend on the specific application. When used in this application, the load transients must be kept small in order to allow the engine to recover without dropping below the knee frequency.

When a large block load is switched on to the system, the engine speed temporarily decreases as the engine produces the additional power requirement by burning more fuel. If the regulator is set to act as a volts per hertz type, it will reduce the output voltage according to the slope of the V/Hz curve. The reduction in voltage reduces the power requirement of the load, thus allowing the engine to recover faster for a given block load. If the regulator is set to act as a constant voltage type, the regulator will not reduce the output voltage for a change in speed (addition of block load). Therefore, it will take the engine a longer time to regain speed and supply the total power requirement of the load. If the regulator is set to act as a constant voltage type, care must be taken to keep block load applications small enough so that the engine can recover in acceptable time.

i02848560

Voltage Regulation

SMCS Code: 4467

The parameters that are related to voltage regulation are listed below.

- Rated Generator Voltage
- Generator PT Primary Voltage Rating
- Generator PT Secondary Voltage Rating
- Voltage Setpoint
- Generator Frequency
- Knee Frequency
- Integral Gain
- Derivative Gain
- Proportional Gain
- Loop Gain

Once startup has been achieved and the generator output frequency is above the corner frequency, the regulator will normally act to keep the generator output voltage constant. As changes in generator loading cause the voltage to sag or rise, the regulator will automatically adjust generator excitation to maintain the output voltage. If loading causes the generator frequency to drop below the knee frequency, the loading and stopping profile as previously described will be followed. See System Operation, "Loading And Stopping Profile".

The CDVR can be connected to a "Manual Voltage Control". For a wiring diagram of "Manual Voltage Control" see Testing and Adjusting, "Wiring diagrams".

A remote voltage adjust toggle switch may be used to fine tune the generator output voltage. When used, the active value of voltage reference may be adjusted $\pm 10\%$.

Voltage can be changed in the software.

1. The voltage can be changed at the "Settings" screen or the "Metering" screen in the CDVR.
2. The voltage can be changed at the "Voltage Regulator Control Parameters" screen with the use of Cat ET.

Note: In order to change the new voltage set point, the "EEPROM" button must be pressed in the CDVR PC software, or the "Enter" key must be pressed in Cat ET after the new set point is entered.

i02847614

Line Loss Compensation

SMCS Code: 4467

In some installations where a single generator is used with long feeder lines to the load, it may be advantageous to provide line loss compensation. Line loss compensation is commonly referred to as IR compensation. In this mode, a CT must be provided in order to measure the generator current.

The parameters that are related to line loss compensation are listed below.

- Rated Generator Voltage
- Generator PT Primary Voltage Rating
- Generator PT Secondary Voltage Rating
- Voltage Set point

- Generator Frequency
- Knee Frequency
- Integral Gain
- Derivative Gain
- Proportional Gain
- Loop Gain
- Generator CT Current Primary Rating
- Generator CT Current Secondary Rating
- Load Compensation Mode
- IR Compensation
- Rated Generator Current
- Knee Frequency
- Integral Gain
- Derivative Gain
- Proportional Gain
- Loop Gain
- Generator CT Current Primary Rating
- Generator CT Current Secondary Rating
- Load Compensation Mode
- Droop Percentage
- Rated Generator Current

Current flowing through a long conductor causes a voltage drop due to the resistance of the wire. Therefore, the voltage at the load end of the conductor will be lower than the voltage at the generator end due to the voltage drop along the conductor. This condition is commonly referred to as line losses. In order to improve the power quality, the digital voltage regulator can compensate for this phenomenon. As generator load increases, the regulator will cause the output voltage to rise slightly at the generator terminals in order to compensate for line losses. Line drop percentage controls the amount of compensation. It should be adjusted to yield a constant voltage at the location of the load.

Line loss compensation is mutually exclusive to reactive voltage droop. These two functions work opposite of one another and can not be used at the same time. If a CT is provided but line loss compensation is not desired, the set point percent must be set to zero.

i02848359

Reactive Voltage Droop

SMCS Code: 4467

The parameters that are related to voltage regulation with reactive droop are listed below.

- Rated Generator Voltage
- Generator PT Primary Voltage Rating
- Generator PT Secondary Voltage Rating
- Voltage Setpoint
- Generator Frequency

When generators operate in parallel, two primary objectives are for the generators to share both the real power requirements and the reactive power requirements of the system electrical load. The engine governors will control sharing of the real power requirements (kW) and the voltage regulator will control sharing of the reactive power requirements (KVAR) of the total system load. If the output voltage of one generator is slightly higher than the other generators, it will supply lagging reactive current to the other generators connected in the group. This current will circulate between generators, possibly causing ampere overloading. One method of minimizing this effect is to cause an individual generator's output voltage to sag, or "droop", in proportion to the lagging reactive current flow from it as measured with a current transformer (CT). For proper reactive load sharing, the regulator must know the rated generator output current, the CT current at rated generator current and the desired percentage of output voltage droop when the generator is at rated reactive output current.

As reactive lagging generator output current increases, the regulator will cause the output voltage to droop (lower the voltage) proportionally. If the measured reactive output current is leading, the output voltage will rise. In either case, this action will tend to reduce the reactive current for better KVAR sharing with other units. The droop percentage controls how much the generator output voltage will vary for a given amount of reactive current. It is important that the connected CT polarity is correct for the voltage to droop with lagging current flow. The CT must be installed on phase B. Reactive droop compensation is mutually exclusive to line droop compensation. These two functions work opposite of one another and can not be used at the same time.

i02848575

Cross Current Compensation

SMCS Code: 4467

The parameters that are related to voltage regulation with “Cross Current Compensation” (CCC) are listed below.

- Rated Generator Voltage
- Generator PT Primary Voltage Rating
- Generator PT Secondary Voltage Rating
- Voltage Set point
- Generator Frequency
- Knee Frequency
- Integral Gain
- Derivative Gain
- Proportional Gain
- Loop Gain
- Generator CT Current Primary Rating
- Generator CT Current Secondary Rating
- Load Compensation Mode
- Droop Percentage
- Rated Generator Current

Cross current compensation is often used in order to minimize circulating current flow between the generators that are connected in parallel. The advantage of this operating mode is that all generators contribute in order to establish the same output voltage to the load. Cross current compensation is only used for paralleling multiple generator sets. Cross current compensation is not used when paralleling with a utility.

Operation is similar to the reactive voltage droop mode except that the secondary circuits of the current transformers of all generators are interconnected in a series string. Each generator is initially adjusted in order to provide the same output voltage.

When all generators share the same current, in magnitude and phase (according to the CT ratio), there will be no significant current output on the secondary of any generator CT. If one of the generators carries more current or the current that the generator carries is lagging or leading relative to the others, a net difference current signal will be created in that CT. If that generator is supplying more reactive (lagging) current than other generators, the phase polarity and the magnitude of the signal returned to the digital voltage regulator will be such to cause a slight decrease in the generated voltage, reducing the amount of reactive current. Less reactive (or more leading) current will cause the generator voltage to rise.

The net result is that the generated voltage and the output current of each generator is trimmed toward an operating point where all generators will share the same load current in proportion to the CT ratio, with the little or no circulating current between them. Droop percentage controls the amount of individual generator voltage droop (or rise) for a given amount of CT signal.

However, because the CT secondary circuits are all interconnected, the CT signal seen by any individual regulator is not representative of the actual current flowing in that particular generator. Any display or calculations that might use that signal as if it were the actual generator current will provide erroneous results.

Reactive voltage droop needs to be selected and an enable contact needs to be closed in order to enable cross current compensation. Refer to the Testing and Adjusting, “Wiring Diagrams” section for a wiring diagram of the cross current compensation circuit.

i02847603

KVAR Regulation

SMCS Code: 4467

Parameters that are related to KVAR regulation are listed below.

- Rated Generator Voltage
- Generator PT Primary Voltage Rating
- Generator PT Secondary Voltage Rating
- Voltage Setpoint
- Generator Frequency
- Knee Frequency

- Integral Gain
- Derivative Gain
- Proportional Gain
- Loop Gain
- Rated Generator Current
- Generator CT Current Primary Rating
- Generator CT Current Secondary Rating
- Operating Mode
- VAR Set point
- VAR Integral Gain
- VAR Loop Gain

When the generator is connected in parallel with an infinite bus (utility), the voltage of the generator is controlled by the infinite bus. The voltage of the generator will change as the infinite bus voltage changes. It is not possible to control the system voltage when the generator is connected to an infinite bus. In this instance, it is necessary for the digital voltage regulator to regulate the reactive power output which is supplied by the generator. There are two methods for regulating the reactive power output.

- KVAR Regulation
- Power Factor (PF) Regulation

Note: KVAR stands for Kilo-Volt-Ampere-Reactive, which is the unit of measurement for reactive power.

When the digital voltage regulator is in the KVAR operating mode, the digital voltage regulator works to produce a constant KVAR output, regardless of the real power output of the generator. In this case, the power factor (generator) will change when the real power output of the generator changes. A current transformer (CT) is necessary for this mode to work. KVAR mode must be selected in software (at the “Metering” screen in the CDVR PC software, or under the “VAR/PF Mode Selection” screen in the Caterpillar Electronic Technician (Cat ET). The contact for the KVAR/PF enable must also be closed. Refer to the following contacts: “P9-6” and “P9-9”.

A remote KVAR/PF adjust toggle switch may be used in order to fine-tune the KVAR set point. Refer to the following contacts: “P9-4”, “P9-5”, and “P9-6”. This switch may be the same switch used for remote voltage adjustment. When the contact for KVAR/PF is closed, and the KVAR mode is selected, the switch will not affect voltage.

Note: The KVAR/PF (Aux breaker) contact does not specify if the CDVR is in KVAR or PF mode specifically. KVAR mode must be selected in software (at the “Metering” screen in the CDVR PC software, or under the “VAR/PF Mode Selection” screen in Cat ET.

Note: When operating in parallel operations, make sure that “Droop” mode is selected in the “Settings” screen in the PC software. A 0% droop may be selected.

In KVAR mode, the generator will supply a constant amount of reactive power to the system as set by the reference (KVAR) regardless of the real power output (kW) of the generator set. The generator will supply real power (kW) to the system. This is determined by the engine governor and/or the device that is used for sharing the load. Due to the amount of reactive power on the utility, current overloading of the system (due to large reactive current requirements) is possible. In the KVAR mode, the generator can supply a fixed amount of reactive power to the system.

For stable operation of the generator in the KVAR regulating mode, the generator must be connected to a utility or a system that is much larger than the generator. When the breaker (tie) is closed to the utility, connect terminal “P9-9” and terminal “P9-6” in order to enable the KVAR mode. When the terminal “P9-9” and terminal “P9-6” are disconnected from each other, the regulator will be in a voltage control operating mode with the following or without the following: droop and line loss compensation.

i02848334

Power Factor Regulation

SMCS Code: 4467

Parameters that are related to PF regulation are listed below.

- Rated Generator Voltage
- Generator PT Primary Voltage Rating
- Generator PT Secondary Voltage Rating
- Voltage Set point
- Generator Frequency
- Knee Frequency
- Integral Gain
- Derivative Gain
- Proportional Gain
- Loop Gain

- Rated Generator Current
- Generator CT Current Primary Rating
- Generator CT Current Secondary Rating
- Operating Mode
- PF Set point
- PF Integral Gain
- PF Loop Gain
- Reactive Droop

When the generator is connected in parallel with an infinite bus (utility), the voltage of the generator is controlled by the infinite bus. The voltage of the generator will change as the infinite bus voltage changes. It is not possible to control the system voltage when the generator is connected to an infinite bus. In this instance, it is necessary for the digital voltage regulator to regulate the reactive power output which is supplied by the generator. There are two methods for regulating the reactive power output.

- KVAR Regulation
- Power Factor Regulation

Note: KVAR stands for kilo-Volt-Ampere-Reactive, which is the unit of measurement for reactive power.

When the digital voltage regulator is in the power factor operating mode, it works to produce a constant power factor, regardless of the real power output of the generator. In this case, the reactive current will change when the real power output of the generator changes. A current transformer (CT) is necessary for this mode to work. PF operating mode must be selected.

For stable operation of the generator in the PF regulating mode, the generator must be connected to a utility or system that is much larger than the generator. When the tie breaker is closed to the utility, connect terminals "P9-9" and "P9-6" in order to enable the PF mode. When the terminals "P9-9" and "P9-6" are disconnected from each other, the regulator will be in a voltage control operating mode with or without droop or line loss compensation as previously described. "PF" mode must be selected in software and the "KVAR/PF" contact must be closed. Refer to the following contacts: "P9-6" and "P9-9". When the contact is not closed the regulator operates in AVR mode.

A remote KVAR/PF adjust toggle switch may be used in order to fine tune the PF set point. Refer to the following contacts: "P9-4", "P9-5", and "P9-6". The remote KVAR/PF switch may be the same switch used for remote voltage adjustment. Raising the PF set point will make the PF more lagging. The lagging PF is a positive PF. Lowering the PF set point will make the PF more leading. The leading PF is a negative PF. When the contact for KVAR/PF is closed, and the PF mode is selected, then the switch will not adjust the voltage setting.

Note: The KVAR/PF contact does not specify if the CDVR is in KVAR or PF mode specifically. PF mode must be selected in software.

Note: When operating in parallel operations, make sure that "Droop" mode is selected. The "Droop" mode must be selected in the "Settings" screen. A 0% droop may be selected.

102847681

Parameters

SMCS Code: 4467

General Information

Parameters are pieces of information which are used within the memory of the digital voltage regulator. Each parameter has a specific range of values. Parameters tell the digital voltage regulator how to operate. Service personnel can configure certain parameters to the requirements of a specific site. Configuration changes the value of a particular parameter. There is an upper and lower limit for the value of each parameter. The limits can not be exceeded.

In order to view or configure the values of the parameters see Testing And Adjusting, "Parameter Viewing And Configuring Procedure".

i02787341

Remote Communication

SMCS Code: 4467

The digital voltage regulator has the capability to communicate with a remote personal computer or programmable logic controller. The J4 connector of the digital voltage regulator provides an RS-232 port necessary for communication. The RS-232 port is a 9-pin communication media including a wire for Receive, a wire for Transmit, and a common Signal Ground. The common signal ground is NOT a bonding ground and should not be grounded to the case or frame. It is to be connected to the RS-232 device Signal Ground connection point. Cable length should be limited to 15 m (50 ft) maximum for the RS-232 signal wiring. Caterpillar 1U-9484 Cable is recommended.

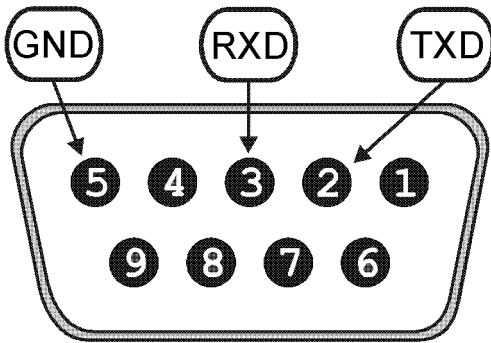

Illustration 8

g01008946

Table 6

Pin	Function	Name	Direction
1	-	-	N/A
2	Transmit Data	TXD	From Regulator
3	Receive Data	RXD	To Regulator
4	-	-	N/A
5	Signal Ground	GND	N/A
6	-	-	N/A
7	-	-	N/A
8	-	-	N/A
9	-	-	N/A

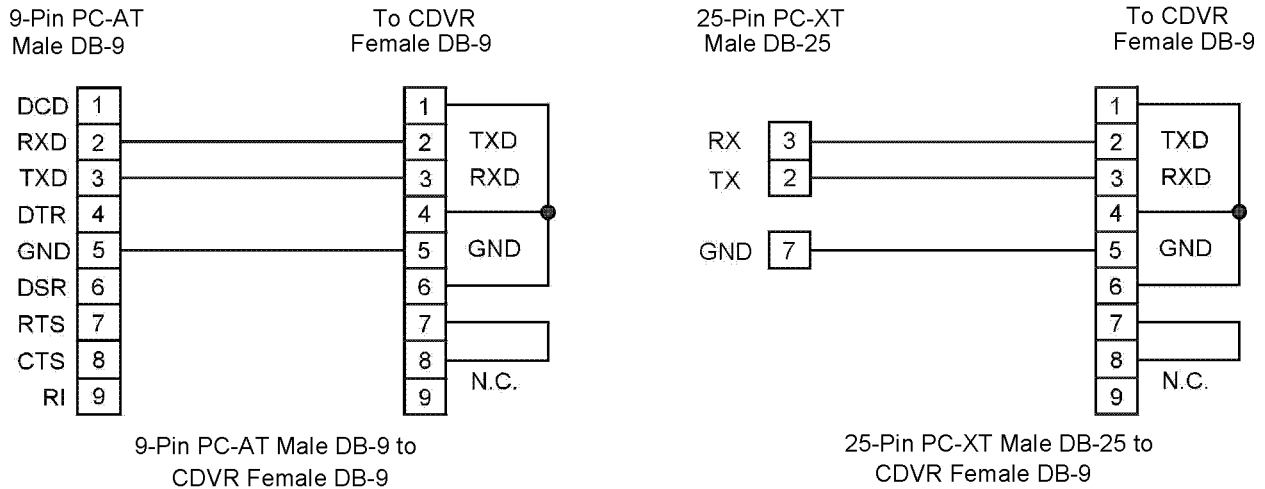

Illustration 9

g01136853

Note: Battery power (24 VDC) must be available at “P12-8” (B+) and “P12-7” (B-) in order for the remote communications port to operate.

A Windows based program is available to communicate with the digital voltage regulator. The Windows program is called Caterpillar PC Software. The part number for the program is 252-7515 Software. The Windows program is available on SisWeb.

Caterpillar PC Software allows the user to perform the following operations.

- Viewing and modifying the parameters in a windowed PC environment
- Sending the parameters to the digital voltage regulator
- Saving the existing digital voltage regulator settings to a file
- Viewing the metering and fault information
- Upgrade embedded firmware

For information on changing and viewing the parameters of the voltage regulator, see Testing and Adjusting, “Parameter Viewing and Configuring Procedure”.

Establishing Communication

Communication between the voltage regulator and the PC software must be established before viewing the metering values, reading settings, or changing settings. PC software screen settings are updated only after communication is opened or the communication settings have been changed. Open the voltage regulator communication port by clicking “Communications” on the menu bar, hovering the mouse pointer over “Open Comm Port” and clicking “RS-232 Port”.

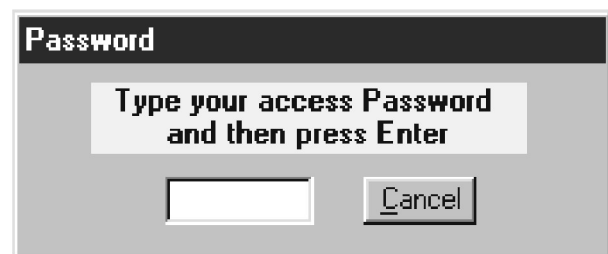

Illustration 10

g01392570

When “RS-232 Port” is selected, the “Password” dialog box appears and prompts you to enter a password. Refer to illustration 10.

Note: Each voltage regulator is delivered with “cat” as the password.

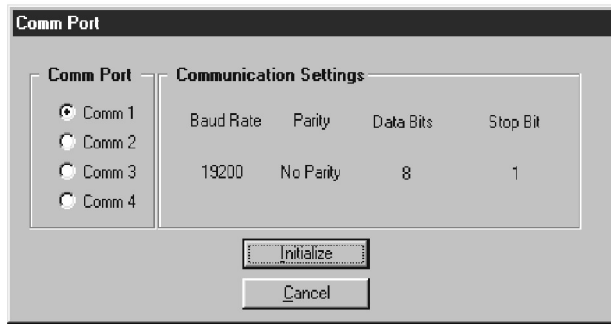

Illustration 11

g01392575

After the correct password is entered, the “Comm Port” screen is displayed. Refer to Illustration 11. Select “Comm 1”, “Comm 2”, “Comm 3”, or “Comm 4” as the active communication port on your PC and click the “Initialize” button. The PC software initializes communication by obtaining the configuration settings from the voltage regulator.



Illustration 12

g01392576

Note: The Caterpillar PC software may display the “Please wait...” dialog box that is shown in Illustration 12 when initializing communication, obtaining configuration settings, or performing other tasks. It is important to wait until the box disappears before trying to execute communication commands. Issuing commands while the “Please wait...” dialog box is present may disrupt communication between the PC software and the voltage regulator.

Terminating Communication

Voltage regulator communication is terminated by clicking “Communications” on the menu bar and clicking “Close Comm Port”. The user will be prompted to save the settings to the EEPROM. This question is asked even if no changes were made to the voltage regulator settings. When the close command is executed (with a Yes or No to save settings to the EEPROM), communication with the voltage regulator is terminated. If the PC software is exited the (by clicking “File” on the “Menu” bar and then “Exit”) without first closing communication, the option will still be given to save the settings to the EEPROM.

Testing and Adjusting Section

i02848393

Testing and Adjusting

i02847378

General Information

SMCS Code: 4467



Illustration 13

g01425354

! DANGER

The Cat Digital Voltage Regulator presents an electrical shock/electrocution hazard. This hazard will cause serious injury or death.

Service by trained personnel only.

The terminals and heat sinks are live at hazardous voltages when power is applied and for up to 8 minutes after power is removed.

Preventive Maintenance

The only preventive maintenance that is required on the voltage regulator is to periodically check the connections between the voltage regulator and the system. The connections must be clean and tight. Voltage regulator units are manufactured using state-of-the-art, surface-mount technology. Caterpillar recommends that no repair procedures be attempted by anyone other than Caterpillar dealer technicians.

Service Tools

SMCS Code: 0785



Illustration 14

g01425366

! DANGER

The Cat Digital Voltage Regulator presents an electrical shock/electrocution hazard. This hazard will cause serious injury or death.

Service by trained personnel only.

The terminals and heat sinks are live at hazardous voltages when power is applied and for up to 8 minutes after power is removed.

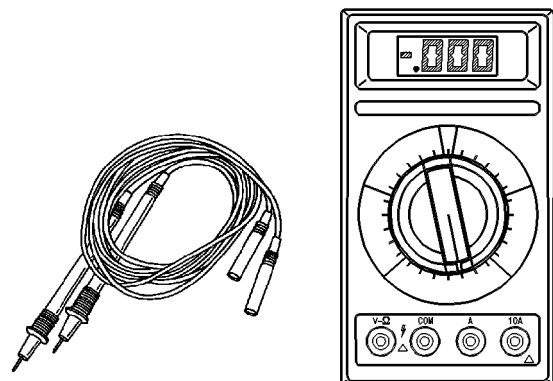

Illustration 15

g00241203

6V - 7070 Caterpillar Digital Multimeter

Caterpillar digital multimeters can be used in order to measure voltage, resistance or current up to 10 amperes. Rectifiers can also be checked by using the diode function. See Special Instruction, SEHS7734, "Use Of The 6V-7070 And 6V-7800 Multimeter" for the correct operation of the 6V - 7070 Digital Multimeter.



Illustration 16 g00538441
8T - 0900 AC/DC Clamp-On Ammeter

The 8T - 0900 Ammeter may be used to measure current up to 1200 amperes. When you are measuring line current on multiple lead units, measure the current in each conductor per phase and add the currents together. See Special Instruction, SEHS8420, "Using the 8T900 AC/DC Clamp On Ammeter 0651" for the correct operation of the 8T - 0900 Ammeter.

i02848479

Startup Procedure

SMCS Code: 4467

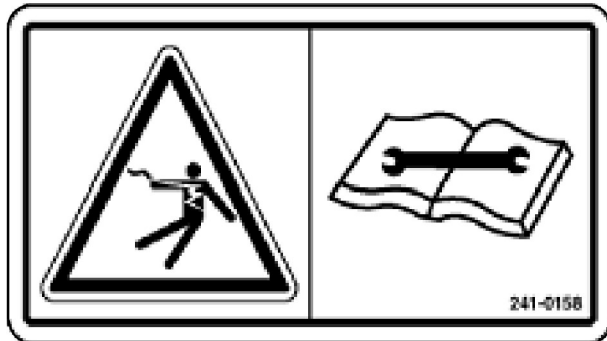

Illustration 17 g01425354

⚠ DANGER

The Cat Digital Voltage Regulator presents an electrical shock/electrocution hazard. This hazard will cause serious injury or death.

Service by trained personnel only.

The terminals and heat sinks are live at hazardous voltages when power is applied and for up to 8 minutes after power is removed.

1. Connect the digital voltage regulator. Refer to Testing and Adjusting, "Wiring Diagrams" for a proper illustration. Take care to follow notes and observe polarities.
2. Apply battery power only to the regulator.
3. Connect serial cable between CATV and PC. Start the CATV PC Software. Establish communication between the CATV and the PC. For more details, refer to "Establishing Communications" located in the "Remote Communication" section.
4. Verify that all of the parameters are properly adjusted for the application. The following fields may need to be entered for first configuration. For more details, refer to "Settings Definitions" located in the "Parameter Viewing and Configuration (Caterpillar PC Software)" section.

a. System Configuration

- **Rated Voltage (V)**
- **Rated Current (A)**
- **Frequency**
- **PT Primary (V)**
- **PT Secondary (V)** - A PT is required if the generator is rated at more than 600 VAC. If no PT is installed, set the PT Primary and PT Secondary to rated voltage.
- **CT Primary**
- **Power Input Frequency (Hz)** - Refer to Table 7.
- **Sensing Mode** - Three phase is the typical Caterpillar setting.

Table 7

Operating Frequency	50HZ	60HZ
Self Excited Generators	50HZ	60HZ
Permanent Magnet Generators Low and Medium Voltage	200HZ	240HZ
6 Pole Generators	133HZ	160HZ
High Voltage 2600 Frame Generators	200HZ	240HZ
High Voltage 2400 and 2800 Frame Generators	150HZ	180Hz

b. Setting Adjustments

- **AVR Voltage (V)** - Desired voltage for AVR mode.

- **VAR (percent of rated)** - For VAR mode.
- **Power Factor** - Must select **Droop** under "Load Compensation Mode" for PF control.
- **Soft Start Bias (percent)** - A starting value for the regulator on startup.
- **Soft Start Time (sec.)** - For emergency applications, this value may need to be set to 2 seconds, or less.
- **Knee Frequency (Hz)** - Select a value that is 0.2 to 2 Hz below rated frequency.
- **Slope 1 (V/Hz)** - 2V per Hz suggested.
- **Slope 2 (V/Hz)** - Refer to Illustration 18.

c. Control Gain Settings

- For applications that require special PID settings, refer to the "Gain Setting - Adjust" section.

d. Protections Settings

- **"Shutdown Override" Button** - Leave disabled.
- **Generator Overvoltage** - Configure as required by the application.
- **Generator Undervoltage** - Configure as required by the application.
- **Reverse VAR** - Configure as required by the application.
- **Fault Reset Too Long** - Configure as required by the application.
- **Over Excitation** - Configure as required by the application.
- **Exciter Diode Monitor** - Configure as required by the application.
- **Loss of Sensing** - Configure as required by the application.
- **Over Excitation: Type** - Threshold is the default setting. If "Inverse Time" is selected, the time setting must be changed to a suggested value of 2 (based on the time dial settings for the SR4B Generator curve). If this value is not changed, over excitation protection may not exist.

5. Press the EEPROM button to save the settings in the CDVR.

6. Start the engine. Make the final adjustments, as required.
7. Press the EEPROM button to save the settings in the CATV.
8. Record all settings. For more details, refer to "Settings File" located in the "Parameter Viewing and Configuration (Caterpillar PC Software)" section.
9. Press "Get From Unit" to verify that the settings were saved.
10. Disable communications (if desired). For more details, refer to "Terminating Communications" located in the "Remote Communication" section.

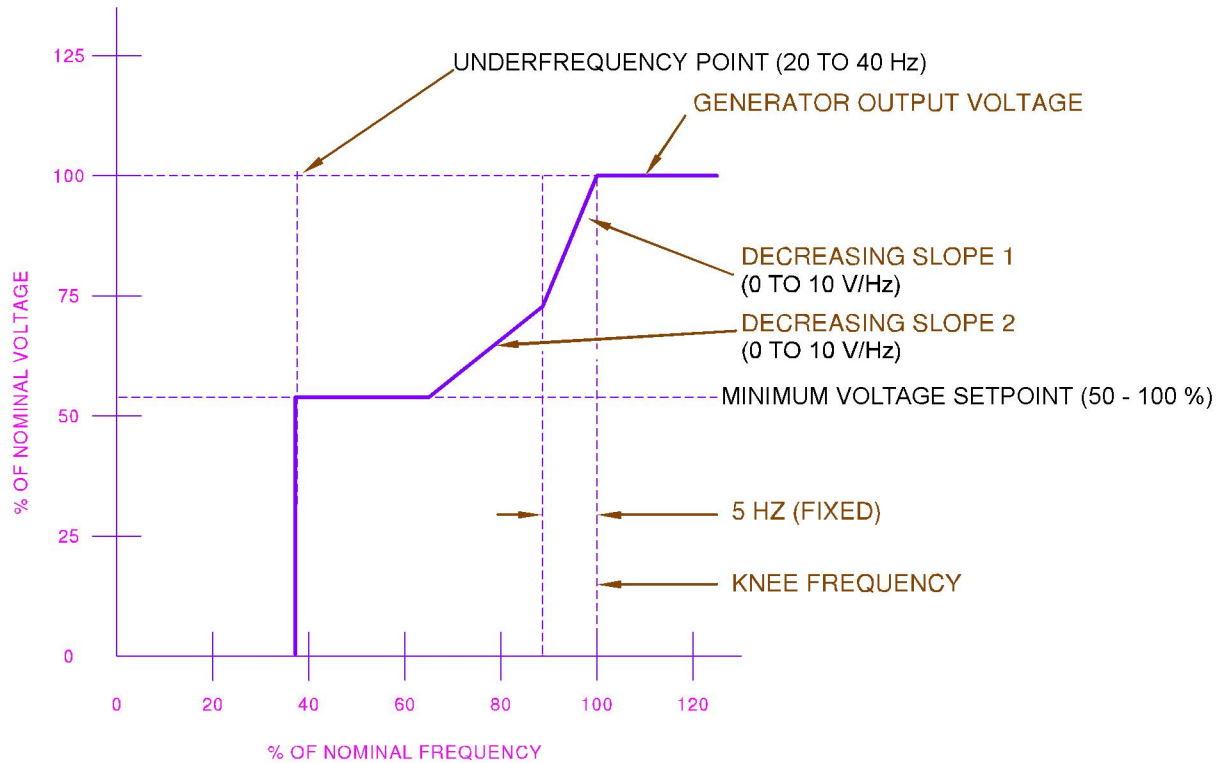

Illustration 18

g01012488

i02788671

Parameter Viewing and Configuration (Caterpillar PC Software)

SMCS Code: 4467-NQ

In order to view and configure the parameters of the digital voltage regulator, a PC with the Caterpillar PC software is required.

Note: Before performing this procedure, study the list of parameters in order to determine the desired parameter and the corresponding range of values. The value of some parameters are only for viewing by the user and may not be configurable.

Note: It will be convenient to have the entire list of parameters available while performing this procedure. See System Operation, "Parameters".

The Caterpillar PC software provides the communication link between the voltage regulator and the user. All voltage regulator settings are entered and read through this software. Within this software, voltage regulator settings can be saved in a computer file and used later in order to configure other units with the same settings.

Caterpillar PC Software operates with an IBM compatible personal computer using a Microsoft Windows 95 or later operating system. The minimum recommended operating requirements are listed below:

- IBM compatible PC, 486DX2 or faster (100 MHz or higher microprocessor is recommended)
- CD-ROM drive
- One available serial port

Installing the Caterpillar PC Software

Caterpillar PC software contains a setup utility that installs the program on the PC. An uninstall utility is loaded with the program that can be used to remove the application from the PC. Use the following procedure to install the PC software.

1. Insert the CD-ROM into the CD-ROM drive of the PC.
2. Click the Windows Start button and then select "Run". In the "Open:" field, enter "D:/Setup.exe", where "D" is the designator letter for your PC CD-ROM drive. Then click "OK".

When Caterpillar PC software is installed, a folder with the name Caterpillar is added to the Windows program menu. This folder is accessed by clicking the “Start” button and pointing to “Programs”.

Starting Caterpillar PC Software

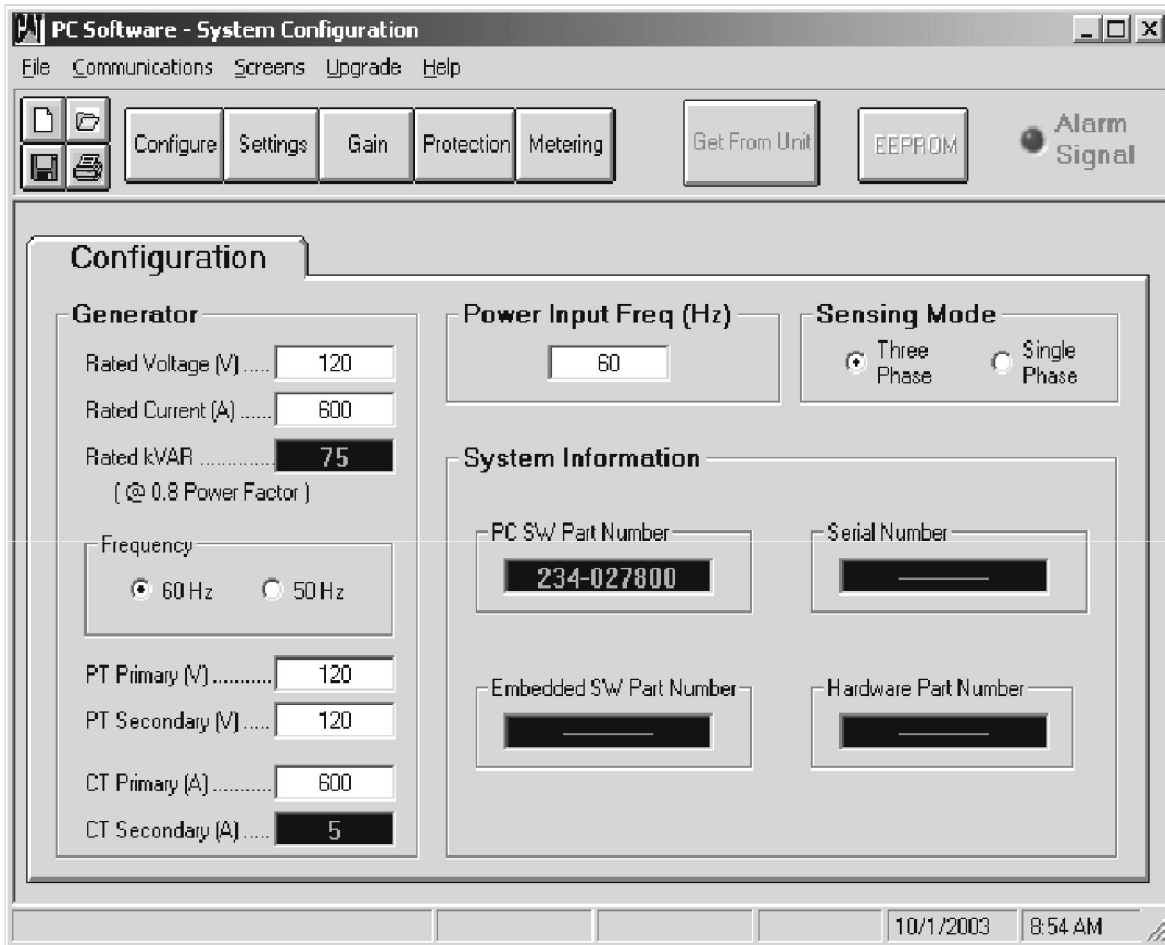

Illustration 19

g01393986

The PC software is started by clicking the Windows “Start” button, pointing to “Programs”, the “Caterpillar” folder, and then clicking the voltage regulator icon. At startup, a dialog box with the program title and version number is displayed briefly. After this dialog box is displayed, the “System Configuration” screen is displayed. See Illustration 19.

Establishing Communication

Communication between the voltage regulator and the PC must be established before any settings can be viewed or changed. For more information on establishing communications, see Systems Operation, “Remote Communication”.

Changing Settings

The settings are arranged into the following five groups:

- System configuration
- Setting Adjustments
- Control Gain Settings
- Protections Settings
- Metering/Operation and Alarms

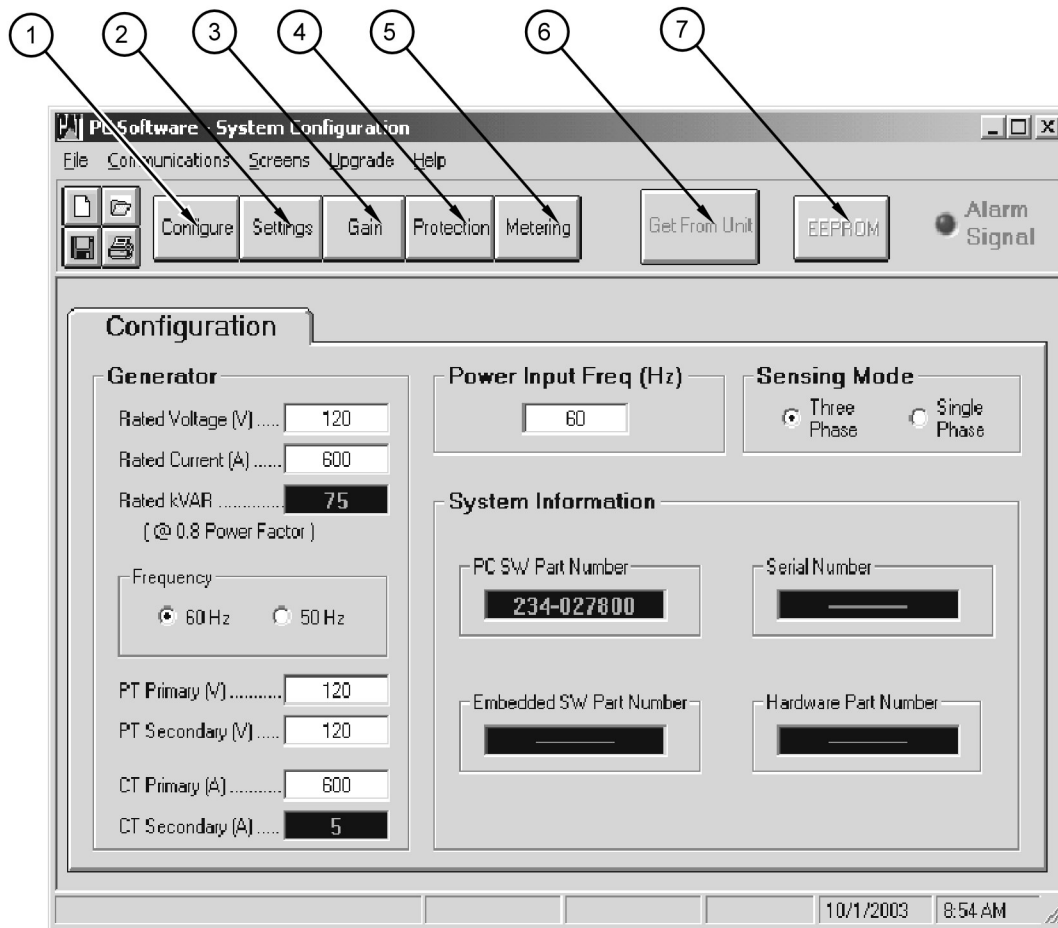

Illustration 20

g01393989

Systems Configuration screen

- (1) System Configuration button
- (2) Setting Adjustment button
- (3) Control Gain Button

- (4) Protection Setting button
- (5) Metering/Operation button
- (6) Get From Unit button

- (7) EEPROM button

Each setting group has a corresponding button that can be selected to access that group of settings. See Illustration 20. The five setting groups can also be accessed by clicking “Screens” on the menu bar and then selecting the desired setting group from the list. Once a setting group is accessed, the individuals settings of the group can be viewed and changed.

A setting is changed by clicking within the setting field and typing the setting. The minimum, maximum and increments (steps) for a setting are displayed on the status bar when the cursor is placed within that setting field. A changed setting is sent to the voltage regulator when the “Enter” key on the PC is pressed. A setting in a field with the pull down menu is sent to the voltage regulator when the setting is selected from the pull down menu.

Sending and Receiving Settings

When communication is enabled, voltage regulator settings can be sent or received through the PC software.

Sending Settings

Settings changes are sent to the voltage regulator by two methods:

1. Type a value in the setting screen field, then press the “Enter” key.

Note: Just typing a value in the setting screen field **WILL NOT** send that value to the CDVR. When a value is typed in the setting screen field, the “Enter” key must also be pressed.

2. Select a value from the setting screen pull down menu.

Note: When a selection is made from the pull down menu, the selected setting that is displayed on the setting screen will automatically be sent to the CDVR and will become the voltage regulator setting. There is **NO** need to press the “Enter” key.

Receiving Settings

Voltage regulator settings are retrieved by clicking the “Get From Unit” button (6). This causes the current settings of the voltage regulator to be displayed on the “settings” screen.

Saving Settings to the Memory of the Voltage Regulator

Settings are saved in nonvolatile memory (EEPROM). In the event of a power loss, these are the settings that will be active at start up. If the settings are changed and sent to the voltage regulator, but the settings are not sent to the EEPROM, the changed settings will be lost if the operating power to the voltage regulator is lost. When exiting an application or closing communication, the software will prompt the user to save the settings to the EEPROM. This question is asked even if no changes were made to the settings. When communication is enabled, setting changes are saved to the EEPROM by clicking the “EEPROM” button (7). The opportunity to save the settings to the EEPROM is also given through a dialog box when the application is exited or communication is closed.

Setting Definitions

Each of the five setting groups have a corresponding screen in the PC software. The setting of each screen are categorized by one or more tabs. In the following paragraphs, setting are arranged and defined according to the organization of the PC application screens and tabs.

System Configuration

The “System Configuration” screen consists of one tab labeled “Configuration”. Click the “Configure” button (1) in order to access the “System Configuration” screen or click “Screens” on the menu bar and click “System Configuration”.

Configuration Tab

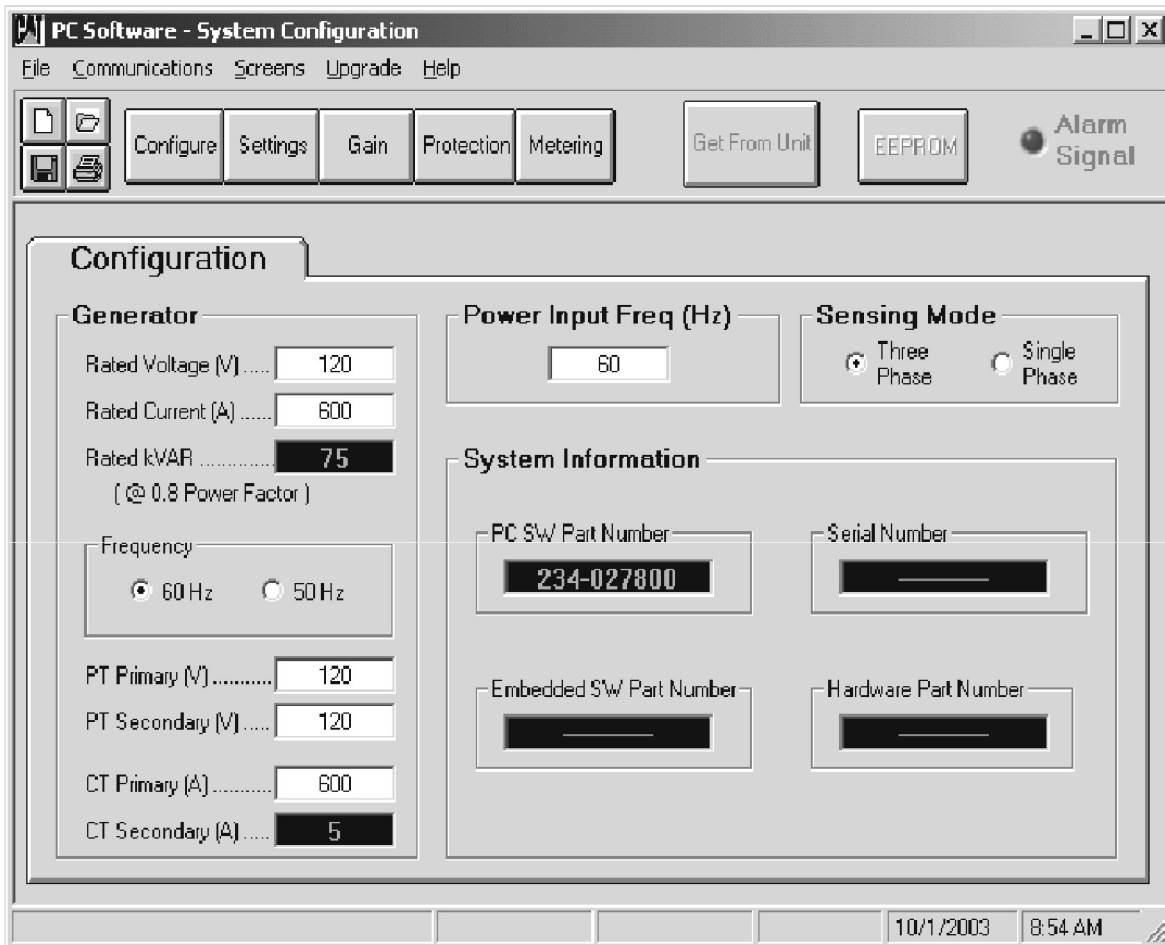

Illustration 21

g01393995

Rated Voltage (V) – The rated AC generator voltage is entered in this field. Voltages within the range of 90 to 15000 VAC may be entered in 1 VAC increments.

Rated Current (A) – The maximum rated AC generator current is entered in this setting field. Current values that are up to 9999 amperes may be entered in 1 ampere increments.

Rated kVAR – This field is a read-only field that displays the rated, calculated reactive power, based on the values that are entered in the Rated Voltage and Rated current fields.

Frequency – This setting is used to select a nominal system operating frequency of 50 Hz or 60Hz.

PT Primary (V) – The primary AC voltage rating of the potential transformer (PT) is entered in this field. Voltages within the range of 90 and 15000 VAC may be entered in 1 VAC increments.

PT Secondary (V) – The secondary AC voltage rating of the PT is entered in this field. Voltages within the range of 90 and 600 VAC may be entered in 1 VAC increments. **Note:** A PT is required if the generator is rated at more than 600 VAC. If no PT is installed, set the PT primary and PT secondary to the expected sensed voltage.

CT Primary – The AC current rating of the primary winding of the CT is entered in this field. Current values that are up to 9999 amperes may be entered in 1 ampere increments.

CT Secondary – This field is a read-only field that displays the rated value of the current that is present at the secondary winding of the CT. This regulator is designed for a 5 ampere secondary winding only.

Power Input Frequency (Hz) – The frequency value of the operating power applied to the voltage regulator is entered in this field. This would be the frequency of the permanent magnet generator or the frequency of the generator in the case of self-excited generator. Frequencies within the range of 50 to 400 Hz may be entered in 1 Hz increments. Refer to table 8 for the correct frequency values.

Table 8

Operating Frequency	50HZ	60HZ
Self Excited Generators	50HZ	60HZ
Permanent Magnet Generators Low and Medium Voltage	200HZ	240HZ
6 Pole Generators	133HZ	160HZ
High Voltage 2600 Frame Generators	200HZ	240HZ
High Voltage 2400 and 2800 Frame Generators	150HZ	180Hz

Sensing Mode – This setting is used to configure the voltage regulator for the single-phase or three-phase voltage sensing. **Note:** For single phase sensing, ensure the “C” phase sensing input is connected to pins P12-10 and P12-11 with the “A” phase sensing input connected to pin P12-12.

PC Software Part Number – This is a read-only field that displays the version of the PC software part number.

Embedded Software Part Number – This is a read-only field that displays the version of the embedded software part number.

Hardware Part Number – This is a read-only field that displays the version of the Hardware part number.

Serial Number – This is a read-only field that displays the serial number of the voltage regulator connected to the PC. Communication between the voltage regulator and the PC must be enabled in order to read the firmware version.

Setting Adjustments

The “Setting Adjustments” screen consists of two tabs labeled “Setpoint” and “Startup”. Click the “Settings” button (2) in order to access the “Setting Adjustments” screen or click “Screens” on the menu bar and click “Setting Adjustments”.

Setpoint Tab

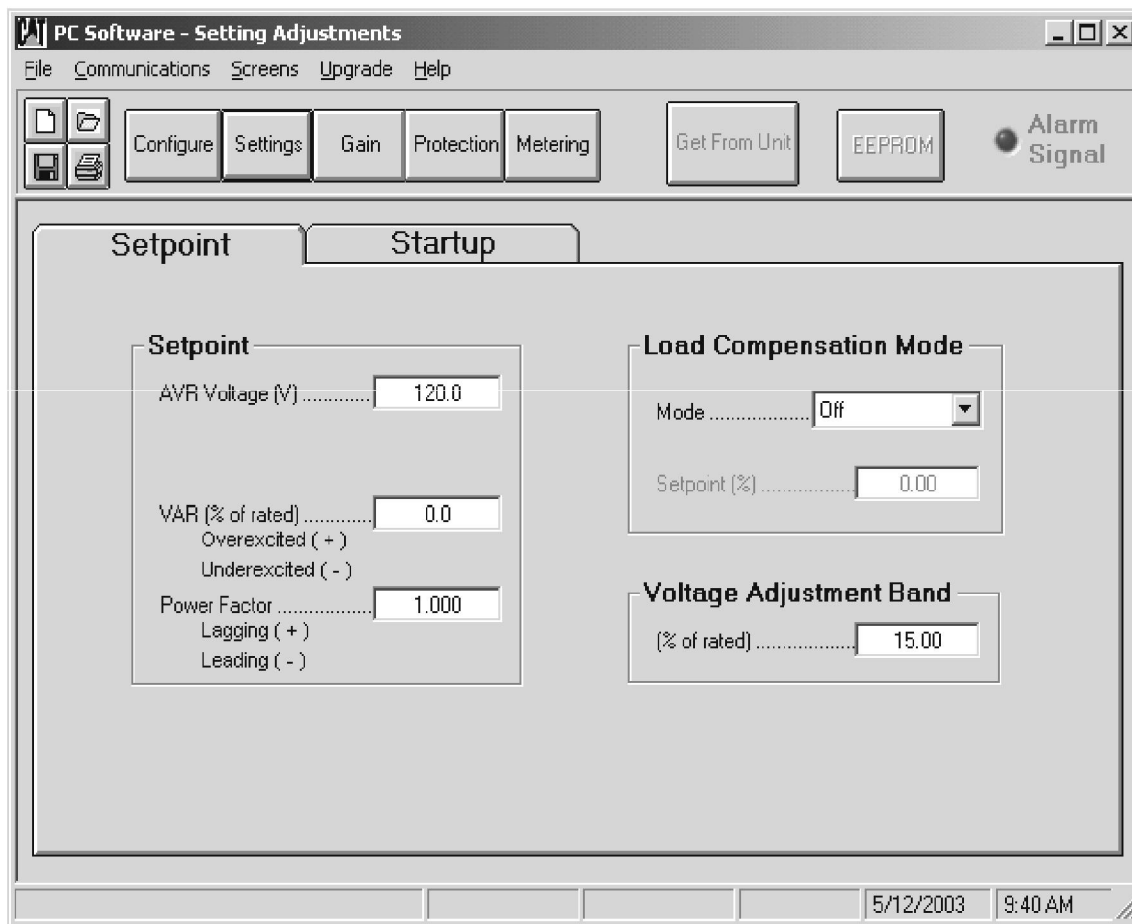

Illustration 22

g01009341

Set point tab as seen without AVR Voltage Control and VAR/PF Control Desired Input Configuration (for original firmware).

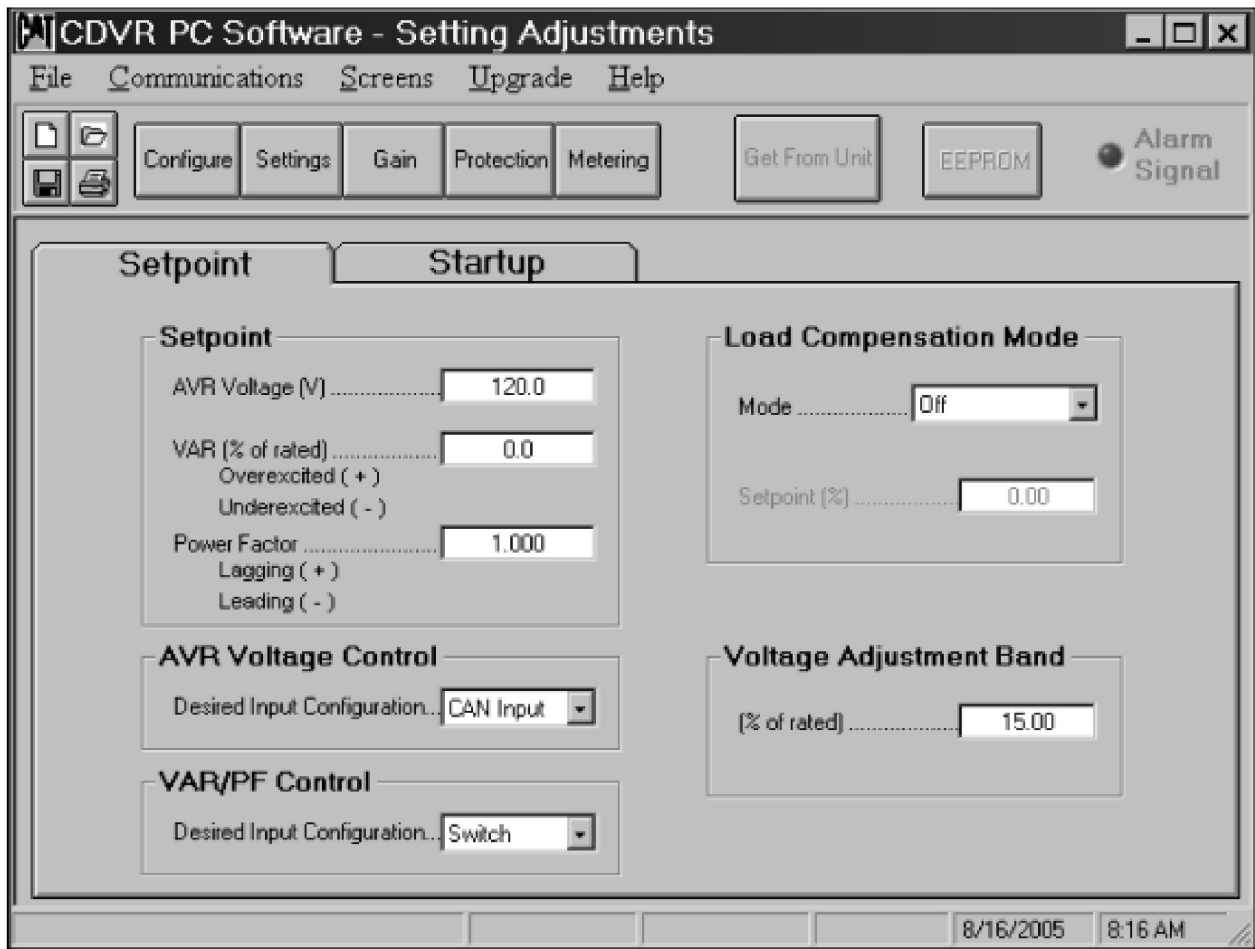

Illustration 23
Setpoint tab with AVR Voltage Control and VAR/PF Control Desired Input Configuration

g01418840

AVR Voltage (V) – This setting field is used to enter the desired generator output terminal voltage. The range of voltages is dependent on the value in the “Voltage Adjustment Band (percent of rated)” field. Values may be entered in increments of 0.1 VAC.

VAR (percent of rated) – The VAR set point determines the level of generator VARs that are maintained by the voltage regulator when the digital voltage regulator is in the VAR mode. Percentage values within the range of -100 to 100 percent may be entered in increments of 0.1 percent. A setting in the overexcited direction will have a positive value and a setting in the under excited direction will have a negative value.

Power Factor – The Power Factor set point determines the level of generator power factor that is maintained by the voltage regulator when the voltage regulator is in the power factor mode. Settings within the range of 0.600 lagging to 0.600 leading may be entered in increments of 0.001. A setting in the lagging direction will have a positive value and a setting in the leading direction will have a negative value. **Before setting a leading power factor, consult the reactive capability curve for the generator being used.**

AVR Voltage Control: Desired Input

Configuration – “CAN Input” and “Switch” are the two settings that can be selected from the drop down menu for this configuration. Selecting “CAN Input” configures the voltage regulator to accept changes to the AVR voltage set point **only** from the “CANbus”. If an attempt is made to change the AVR set point with this configuration, from the “Settings” screen, with the use of the “Raise” or “Lower” buttons while at the “Metering” screen, and with the “Raise” or “Lower” contacts, then the adjustment will have no effect. Selecting “Switch” configures the voltage regulator to accept changes to the AVR voltage set point from the “Settings” screen, the “Raise” or “Lower” buttons in the “Metering” screen, or by the use of the “Raise” or “Lower” contacts. The CANbus will have no effect. If “CAN Input” is selected and the CANbus communication is not available, the voltage regulator will not automatically change to the “Switch” setting. The user must use software to manually change this setting to “Switch” in order to have AVR voltage set point control. However, changing the AVR set point from the “Settings” screen or using the “Raise” or “Lower” buttons in the “Metering” screen will allow for changes to the AVR set point.

VAR/PF Control: Desired Input Configuration – “CAN Input” and “Switch” are the two settings that can be selected from the drop down menu for this configuration. Selecting “CAN Input” configures the voltage regulator to accept changes to the VAR/PF voltage set point **only** from the “CANbus”. If an attempt is made to change the VAR/PF set point with this configuration, from the “Settings” screen, with the use of the “Raise” or “Lower” buttons while at the “Metering” screen, and with the “Raise” or “Lower” contacts, then the adjustment will have no effect. Selecting “Switch” configures the voltage regulator to accept changes to the VAR/PF voltage set point from the “Settings” screen, with the use of the “Raise” or “Lower” buttons while at the “Metering” screen, and with the “Raise” or “Lower” contacts. The CANbus will have no effect. If “CAN Input” is selected and the CANbus communication is not available, the voltage regulator will not automatically change to the “Switch” setting. The user must use software to manually change this setting to “Switch” in order to have VAR/PF voltage set point control. However, changing the VAR/PF set point from the “Settings” screen or using the “Raise” or “Lower” buttons in the “Metering” screen will allow for changes to the VAR/PF set point.

Load Compensation Mode: Mode – Three settings may be selected from the drop down menu for this operating mode: “Off”, “Droop”, or “Line Drop” (Line Loss). Selecting “Off” disables all load compensation. Selecting “Droop” enables the reactive droop compensation feature of the voltage regulator. Selecting “Line Drop” enables the voltage regulator to compensate for a line drop by increasing the generator output voltage as the generator load increases.

When operating in parallel operations, make sure Droop mode is selected.

“Reactive Droop Compensation” and “Line Drop Compensation” are briefly described below:

Reactive Droop Compensation - The voltage regulator provides a “Reactive Droop Compensation” feature for three phase generators in order to assist in the sharing of reactive load during parallel generator operation. The voltage regulator calculates the reactive portion of the generator load using the sensed generator output voltage and current quantities. The voltage regulator then modifies the voltage regulation set point accordingly.

- A unity power factor generator load results in almost no change in generator output voltage.
- A lagging power factor generator load (inductive) results in a reduction of generator output voltage.
- A leading power factor generator load (capacitive) results in an increase of generator output voltage.

Droop is adjustable up to 10 percent with rated “B phase” line currents and 0.8 power factor. The “B phase” line currents are 5 amperes applied through terminals P12-1 and P12-2. The droop is adjustable with the use of the communication port(s).

“Reactive Droop Compensation” is mutually exclusive to line drop compensation. These two functions work opposite of one another and, therefore, cannot be used at the same time.

In addition, the “Reactive Droop Compensation” feature allows paralleling of three phase generators when connected for “Cross Current Compensation” (CCC). The CCC method of connection allows reactive load shared between generators with very little voltage droop. The droop level adjustment acts as the sensitivity adjustment when connected for CCC.

Verify that the system works in reactive droop mode before connecting in CCC mode.

Note: When in CCC mode, kW and/or kVAR may indicate negative values in the “Metering” screen.

Line Drop Compensation - The voltage regulator provides a “Line Drop Compensation” feature for three phase generators in order to assist in compensating for voltage drops in the lines between the generator and the load. The voltage regulator calculates the magnitude of generator output current and modifies the voltage set point accordingly. An increase in generator output current results in an increase in generator output voltage. “Line Drop Compensation” is adjustable up to 10 percent with rated “B phase” line currents and 0.8 power factor. The “B phase” line currents are 5 amperes applied through terminals P12-1 and P12-2. The droop is adjustable with the use of the communication port(s). “Line Drop Compensation” is mutually exclusive to “Droop”. “Line Drop Compensation” and “Droop” work opposite of one another and, therefore, cannot be used at the same time.

Load Compensation Mode: Setpoint (percent) – The “Load Compensation Mode” setting field is enabled only when “Droop” or “Line Drop” is selected as the “Load Compensation” mode. A percentage of zero to 10.00 percent may be entered in increments of 0.01.

Voltage Adjustment Band (percent of rated) – The “Voltage Adjustment Band” setting is entered as a percentage of the rated generator voltage. “Voltage Adjustment Band” is used to limit the range of the AVR set point. A percentage value of zero to 15.00 percent may be entered in increments of 0.01.

Note: Adjusting the voltage using the DC bias input or the “Fine Adjustment” buttons in the CDVR PC software will only change the voltage set point. Adjusting the voltage using the DC bias input or the “Fine Adjustment” buttons will not change the voltage adjustment band.

Startup Tab

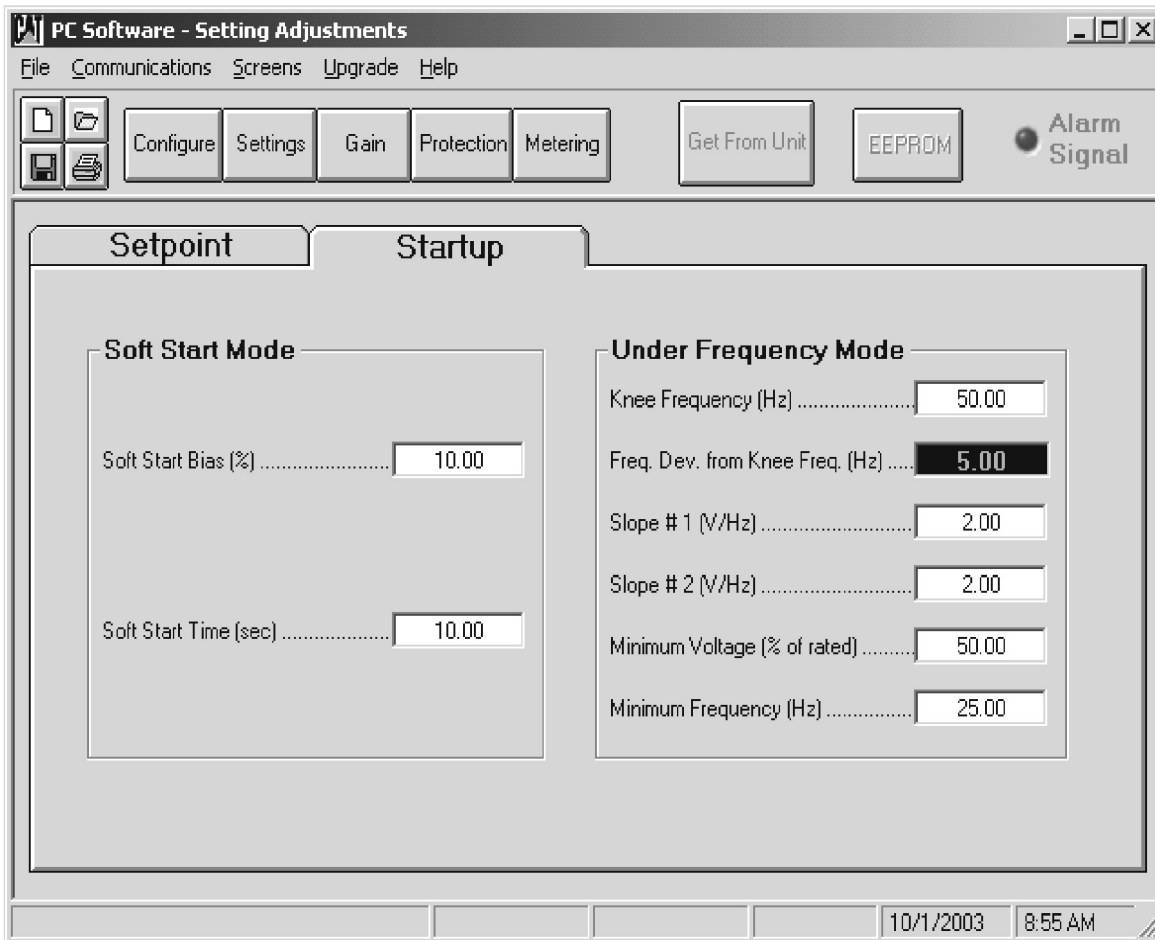

Illustration 24

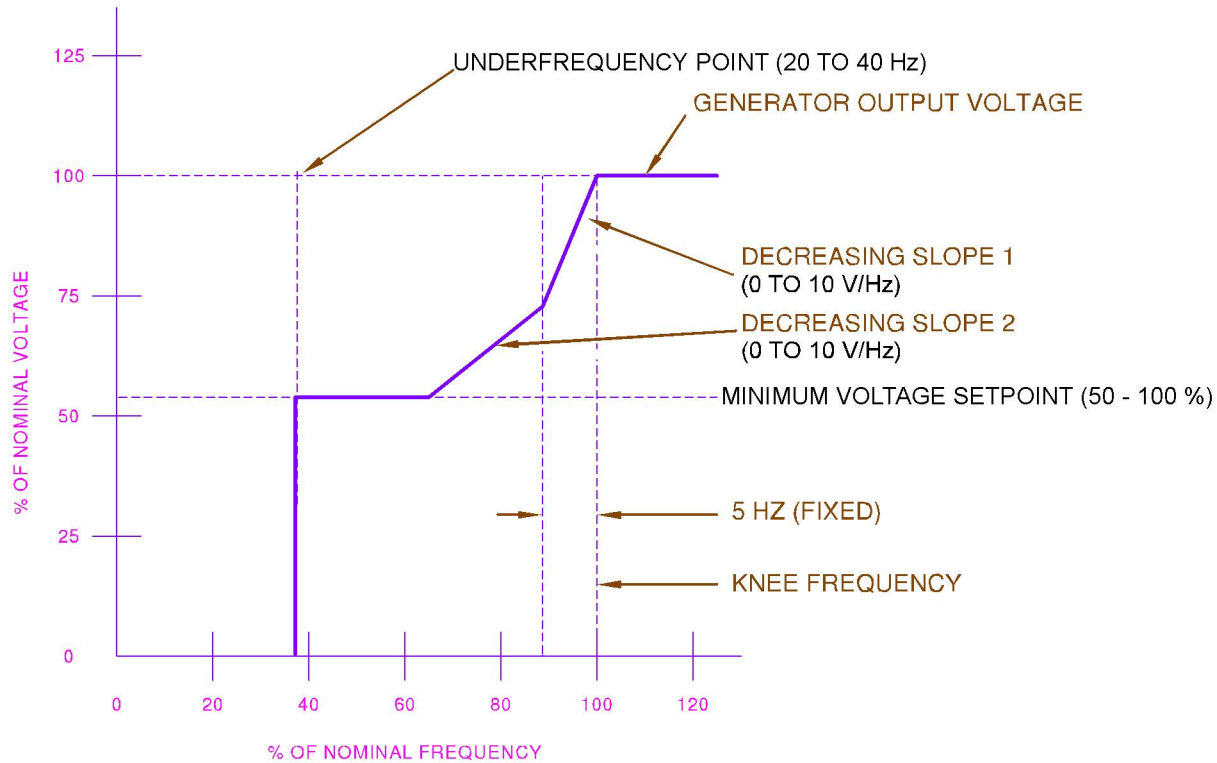

Illustration 25

g01012488

Soft Start Bias (percent) – The Soft Start Bias setting determines the generator voltage offset during start up as a percentage of the generator rated voltage. The CDVR will raise output voltage to this percentage as quickly as possible. A percentage value of 0.00 to 90.00 may be entered in increments of 0.01 percent.

Soft Start Time (sec.) – The Soft Start Time establishes the length of time for the generator terminal voltage to increase to the generator rated voltage level from the “Soft Start Bias” percent. A value of 0.00 to 120.00 seconds may be entered in increments of 0.01 seconds. If the “Under Frequency Point” is reached before the CDVR reaches the “Soft Start Bias” percent, voltage will build from the “Soft Start Bias” percent, in a linear manner, for the duration of the “Soft Start Time”. If the “Under Frequency Point” is reached after the CDVR reaches the “Soft Start Bias” percent, voltage will build from the “Soft Start Bias” percent, in a linear manner, until the “Under Frequency Point” is reached. From there, voltage will build following a “volts-per-hertz” profile. Refer to Illustration 25.

Knee Frequency (Hz) – The “Knee Frequency” setting defines the value of frequency that causes the voltage regulator to adjust the voltage set point so that the generator terminal voltage follows the selected volts per hertz slope. A value of 45.00 to 65.00 hertz may be entered in increments of 0.01 hertz. “Knee Frequency” should typically be set from 0.2 to 2 Hz less than the generator operating frequency. The knee frequency should be adjusted closer to the nominal frequency in applications where the generator engine and governor is slow in recovering frequency during a transient load event.

Frequency Deviation from Corner Frequency (Hz) – This field is a “read-only” field. The fixed value is subtracted from the “Corner Frequency” value in order to determine when the generator under frequency operation changes from slope 1 to slope 2.

Slope 1 (V/Hz) – When the generator frequency is between the corner frequency and the corner frequency minus 5 hertz, the voltage set point is automatically adjusted so that the generator voltage follows volts per hertz slope 1. Slope 1 is adjusted by this setting field. A setting of zero to 10.00 may be entered in increments of 0.01.

Slope 2 (V/Hz) – When the generator frequency is between the corner frequency minus 5 hertz and the “Minimum Frequency” setting, the voltage set point is automatically adjusted so that the generator voltage follows volts per hertz slope 2. Slope 2 is adjusted by this setting field. A setting of zero to 10.00 may be entered in increments of 0.01.

Note: Volts per Hz slope value can be used to improve transient response time.

Minimum Voltage (percent of rated) – The “Minimum Voltage” setting defines the voltage level where the voltage regulator transitions from the under frequency characteristic to a constant voltage characteristic. The “Minimum Voltage” setting is expressed as a percentage of nominal generator voltage. A value of 50.00 to 100.00 percent may be entered in increments of 0.01.

Minimum Frequency (Hz) – The “Minimum Frequency” setting defines the value of the generator frequency where the excitation is removed. A frequency value of 20.00 to 40.00 hertz may be entered in increments of 0.01 hertz.

Control Gain

The “Control Gain” screen consists of a single tab labeled “Control Gain”. Click the “Gain” button (3) in order to access the “Control Gain” screen or click “Screens” on the menu bar and click “Control Gain”.

Control Gain Tab

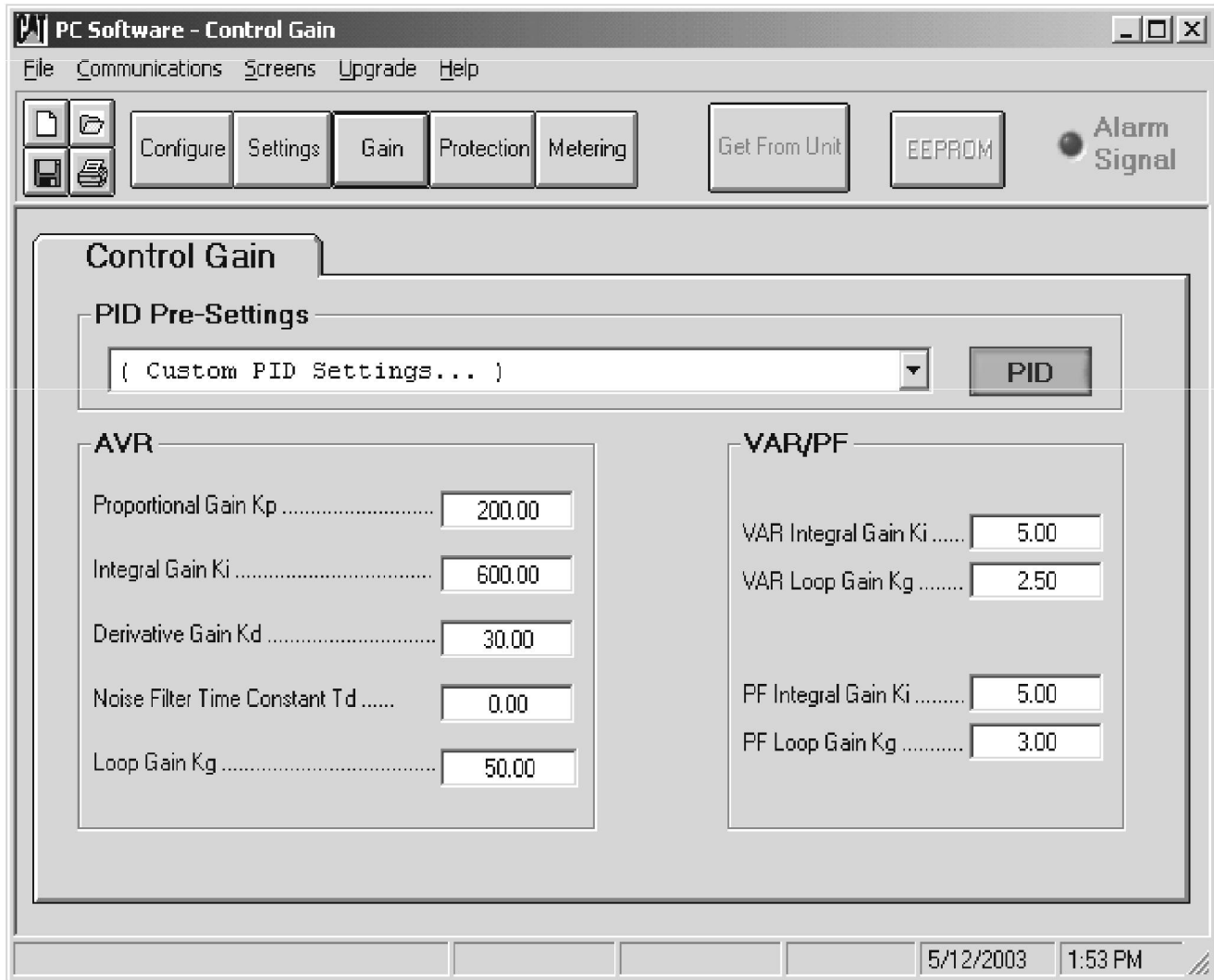

Illustration 26

g01009752

Proportional Gain Kp – This setting selects the proportional constant stability parameter. The voltage regulator supplies a value that is equivalent to K_p multiplied by the error between the voltage set point and the actual generator output voltage. K_p values of 0 to 1,000 may be entered in increments of 0.01.

If the transient response has too much overshoot, then K_p may be decreased. If the transient response is too slow, then K_p may be increased.

Integral Gain Ki – This setting selects the integral constant stability parameter. The voltage regulator supplies a value that is equivalent to K_i multiplied by the integral of the error between the voltage set point and the actual generator output voltage. K_i values of 0 to 1,000 may be entered in increments of 0.01.

Increasing the value of K_i decreases the time required to reach steady state.

Derivative Gain Kd – This setting selects the derivative constant stability parameter. The voltage regulator provides an output value that is equivalent to K_d multiplied by the derivative of the error between the voltage set point and the actual generator output voltage. K_d values of 0 to 1,000 may be entered in increments of 0.01.

Increasing the value of K_d reduces transient response ringing.

Noise Filter Time Constant Td – This setting selects the noise filter time constant and is used in order to reduce high frequency noise. Values of 0.00 to 1.00 may be entered in increments of 0.01.

Loop Gain Kg – This setting adjusts the loop-gain level of the PID algorithm. Loop gain values of 0 to 1,000 may be entered in increments of 0.01. Loop gain Kg is an overall gain multiplier affecting all gain parameters, and should be used as a first gain adjustment. Increasing loop gain may be used to increase transient response and reduce time to steady state. Decreasing loop gain will reduce overshoot but will lengthen time to steady state. For self excited machines, a low value may be required for stability. This value may be as low as 5. Refer to the “Poor Voltage Regulation - Troubleshoot” section.

VAR Integral Gain Ki – This setting adjusts the integral gain and determines the characteristic of the voltage regulator dynamic response to a changed VAR setting. Ki values of 0 to 1,000 may be entered in increments of 0.01.

VAR Loop Gain Kg – This setting adjusts the loop gain level of the PI algorithm for VAR control. Values of 0 to 1,000 may be entered in increments of 0.01.

PF Integral Gain Ki – This setting adjusts the integral gain and determines the characteristic of the voltage regulator dynamic response to a changed power factor setting. Values of 0 to 1,000 may be entered in increments of 0.01.

PF Loop Gain Kg – This setting adjusts the loop gain level of the PI algorithm for power factor control. Values of 0 to 1,000 may be entered in increments of 0.01.

PID Pre-Settings – One of 20 preset stability ranges within the voltage regulator can be selected from this pull down menu. Selection of one of the 20 preset stability ranges disables the “Proportional Gain” (Kp), “Integral Gain” (Ki), and “Derivative Gain” (Kd) settings of the “Control Gain” tab. Selecting “Custom PID Settings” from the “PID Pre-Settings” menu enables the Kp, Ki, and Kd settings. Caterpillar does not recommend using the current “PID Pre-Settings” in the list except the “Custom PID Settings”. The default settings from the “Custom PID Settings” will work well for most SR4 and SR4B generator applications. If an adjustment is to be made, the “Loop Gain Kg” should be used as a first adjustment approach.

“PID” Button – Press the PID button in order to open the PID “Calculator” screen. See illustration 27. The PID “Calculator” is used in order to calculate proportional gain (Kp), integral gain (Ki), and derivative gain (Kd) for a PID type controller. The generator and the exciter time constant values are entered into the “PID Calculator” in order to calculate these values. AVR overall gain (Kg) and derivative filter time constant (Td) can be entered and saved in a file. Refer to the “PID Calculator” section for additional information.

PID Calculator

Caterpillar - PID Calculator

File Help

Excitation Control Data

Gen. Information Generator Name

Gen. Time Constant [T'do] - (Seconds) 2.00

Default Exciter Time Constant

Exciter Time Constant [Te] - (Seconds) 0.33

AVR Control Parameters

Proportional Gain (Kp) 84.83

Integral Gain (Ki) 141.31

Derivative Gain (Kd) 13.51

Time Constant (Td) 0.08

AVR Overall Gain (Kg) 1.00

PID Record List

Generator Information	Kg	Kp	Ki	Kd	Td	T'do	Te
PID Record List							

Remove Record Add Record Update CAT PC Software Close

Illustration 27

g01009819

The PID parameters are calculated for the desired system response with a settling time of about one third of the generator time constant and about 10 percent overshoot.

Excitation Control Data

Gen. Information – Up to 20 characters of descriptive text for the generator can be entered in this field. When a PID record is created, this text identifies the record.

Gen Time Constant (T'do) - (Seconds) – The open circuit generator time constant (T'do) can be selected from this pull down menu. Time constant values of 1 to 15 seconds can be entered in 0.05 second increments.

Note: Values for specific generators can be obtained from the “Technical Marketing Information System”.

Exciter Time Constant (Te) - (Seconds) – The exciter time constant (Te) can be selected from this pull down menu. The value displayed in this menu depend on the generator time constant (T'do) that is selected. Available values range from one fifth to one half of (T'do) in 0.01 second increments. The maximum possible exciter time constant is 3 seconds.

Default Exciter Time Constant – When this box is checked, manual selection of the exciter time constant is disabled and Te is set at one-sixth the value of the generator time constant (T'do). This is not recommended for SR4 and SR4B generators.

AVR Control Parameters

Proportional Gain (Kp) – This is a read only value. The value is calculated from the values that are selected from the generator time constant (T'do) and exciter time constant (Te) pull down menus.

Integral Gain (Ki) – This is a read only value. The value is calculated from the values that are selected from the generator time constant (T'do) and exciter time constant (Te) pull down menus.

Derivative Gain (Kd) – This is a read-only value. The value is calculated from the values selected from the generator time constant (T'do) and exciter time constant (Te) pull down menus.

Time Constant (Td) – The time constant value entered in this field is used to reduce high frequency noise. The Td value entered is recommended to be less than 0.2 (Kd, Kp). Td values from zero to 1.00 may be entered in 0.01 increments. Entering a value of “zero” disables the filtering.

AVR Overall Gain (Kg) – The AVR overall gain is entered in this field. A Kg value of zero to 1000.00 may be entered. **Note:** If the “Update CDVR PC Software” button is pressed, a default value of 1.00 is loaded into this field. Make sure to adjust this value as needed.

PID Record List

This area of the PID “Calculator” screen lists all of the saved PID records that are available.

Remove Record Button – Records in the “PID Record List” can be selected and deleted by clicking this button.

Add Record Button – A record containing the excitation control data and AVR control parameters can be added to the “PID Record List” by clicking this button. The “Save” button must be pressed in order to save the record in the list.

Update CAT PC Software Button – Transfers the AVR control parameters calculated in the PID calculator and recorded to the “Control Gain” screen.

Close Button – Clicking this button closes the “PID Calculator” and returns to the “Control Gain” screen.

Table 9

Power Input to Voltage Regulator (PM / SE / AREP Systems)					Power Input to Exciter					
					Nominal Requirements				Full Forcing Requirements	
	SE/PM Voltage	Input to Regulator	Frequency Range	Number of Phases	Exciter Nominal Voltage Input	Exciter Nominal Current Input	Exciter Resistance	Exciter Time Constant Te	Full Forcing Voltage	Full Forcing Current
Kato 2600/2700 Frame	PM	70 to 105V	240 Hz	3	35V	10A	3.7 ohms	0.22 sec	65V	15A
Kato 2800 Frame	PM	120V	90 Hz	1	50V	5A	10 ohms	0.18 sec	90V	10A
6100	PM	140V	120 Hz	3	40V	4A	10 ohms	0.22 sec	60V	10A
6100	SE	140V	60 Hz	1	40V	4A	10 ohms	0.22 sec	60V	10A
6100	AREP	140V	50/180 Hz	2x1	40V	4A	10 ohms	0.22 sec	60V	10A
1400 /4P	PM	180V	200/240 Hz	3	45V	4.5A	11 ohms	0.06 sec	80V	10A
1400 /4P	AREP	140V	50/180 Hz	2x1	45V	4.5A	10 ohms	0.06 sec	80V	10A
1600 /4P	PM	180V	200/240 Hz	3	60V	6A	10 ohms	0.094 sec	150V	15A
1600 /4P	AREP	240 V	50/180 Hz	2x1	60V	6A	10 ohms	0.094 sec	150V	15A
1800 /4P	PM	180V	240 Hz	3	84V	4A	11 ohms	0.26 sec	190V	8.5A
1800 /4P	AREP	240V	60 Hz	1	84V	4A	11 ohms	0.26 sec	190V	8.5A
SR4/ SR4B	PM	70 to 105V	240 Hz	3	35V	10A	3.7 ohms	0.22 sec	65V	15A
SR4/ SR4B	SE	240V	60 Hz	1	35V	10A	3.7 ohms	0.22 sec	65V	15A

Protection Settings

The “Protection Settings” screen consists of a single tab labeled “Protection”. Click the “Protection” button to access the “Protection Settings” screen or click “Screens” on the menu bar and click “Protection Settings”.

Protection Tab

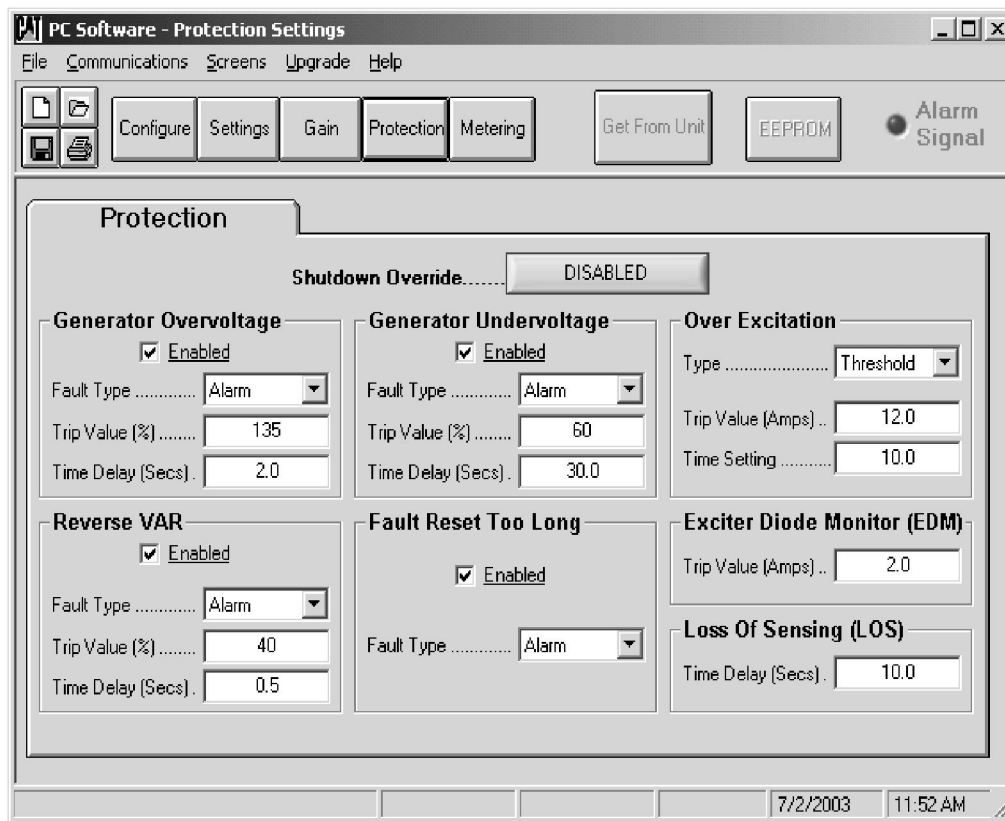

Illustration 28

g01009884

“SHUTDOWN OVERRIDE” Button – This button is used to prevent excitation shutdown for any protected function. The button displays “ENABLED” when selected and the button displays “DISABLED” when the button is deselected. Enabling this button does not disable output drivers or “CANbus” messages. The following protections do not rely on disabling excitation to cause a shutdown and, therefore, are not affected by the “Shutdown Override” button.

- Generator Over voltage
- Generator Under voltage
- Loss of Excitation (Reverse Var)
- Fault Reset too long

Note: The position of this button cannot be saved into the EEPROM. The default value of “Disabled” is loaded when power is cycled on the CDVR.

Generator Over voltage: Enabled – Selecting the “Enabled” check box enables generator over voltage protection. Deselecting the “Enabled” check box disables generator over voltage protection and the associated settings.

Generator Over voltage: Fault Type – Two options can be selected from this pull down menu, “Alarm” or “Shutdown”. When “Alarm” is selected and a generator over voltage condition is detected, the alarm output driver energizes, a J1939 alarm message is sent via the “CAN” communication port, and the “Fault LED” will be lit constantly. For units equipped with an RS-232 communication port, an Alarm fault will be annunciated via the PC software. When “Shutdown” is selected and a generator over voltage condition is detected, the “Fault Shutdown” output driver energizes, a J1939 shutdown message is sent, and the “Fault LED” will flash. For units equipped with an RS-232 communication port, a “Shutdown” fault will be annunciated via the PC software. **The voltage regulator does NOT disable excitation when a “Generator Over Voltage” fault is detected.**

Generator Over Voltage: Trip Value (percent) –

This setting determines the voltage threshold where an over voltage trip will occur. Voltage values of 105 to 135 percent of the rated voltage may be entered in increments of 1 percent.

Generator Over Voltage: Time Delay (Sec.) –

This setting assigns the length of time from when an over voltage condition is detected until the voltage regulator issues an alarm or shuts down excitation. A time value of 2.0 to 30 seconds may be entered in 0.1 second increments.

Reverse VAR: Enabled – Selecting the “Enabled” check box enables reverse VAR protection. Deselecting the “Enabled” check box disables reverse VAR protection and the associated settings.

Note: If “Reverse VAR” protection is enabled and the CT connections are reversed, a reverse VAR alarm or shutdown will occur.

Reverse VAR: Fault Type – Two options can be selected from this pull down menu, “Alarm” or “Shutdown”. When “Alarm” is selected and loss of excitation is detected, the alarm output driver energizes, a J1939 alarm message is sent via the “CAN” communication port, and the “Fault LED” is lit constantly. For units equipped with an RS-232 communication port, an alarm fault will be annunciated via the PC software. When “Shutdown” is selected and loss of excitation is detected, the “Fault Shutdown” output driver energizes, a J1939 shutdown message is sent via the “CAN” communication port, and the “Fault LED” flashes. For units equipped with an RS-232 communication port, a shutdown fault will be annunciated via the PC software. **The voltage regulator does NOT disable excitation when a Loss of Excitation (Reverse Var) fault is detected.**

Reverse VAR: Trip Value (percent) – This setting determines the level of reverse VAR flow, expressed as a percentage of nominal, positive VAR flow, where a loss of excitation trip occurs. A value of 10 to 100 percent may be entered in increments of 1 percent.

Reverse VAR: Time Delay (Secs) – This setting assigns the length of time from when the reverse VAR trip value is exceeded until the voltage regulator issues an alarm or shuts down. A time value of 0.1 to 9.9 seconds may be entered in 0.1 second increments.

Generator Under Voltage: Enabled – Selecting the “Enabled” check box enables generator under voltage protection. Deselecting the “Enabled” check box disables generator under voltage protection and the associated settings.

Generator Under Voltage: Fault Type – Two options can be selected from this pull down menu, “Alarm” or “Shutdown”. When “Alarm” is selected and a generator under voltage is detected, the “Alarm” output driver will energize. A J1939 alarm message is sent via the “CAN” communication port. Also, the “Fault LED” is on constantly. For units that are equipped with an RS-232 communication port, an “Alarm” fault will be annunciated via the PC software. When “Shutdown” is selected and a generator under voltage is detected, the “Shutdown” output driver will energize. A J1939 shutdown message is sent via the CAN communication port. The “Fault LED” will flash. For units that are equipped with an RS-232 communication port, a “Shutdown” fault will be annunciated via the PC software. **The voltage regulator does NOT disable excitation when a “Generator Under Voltage” fault is detected.**

Generator Under Voltage: Trip Value (percent) –

This setting determines the level of voltage. The value is expressed as a percentage of nominal generator voltage when a generator under voltage trip occurs. A value of 60 to 95 percent may be entered in 1 percent increments.

Generator Under Voltage: Time Delay (Secs) –

This setting assigns the length of time from when a generator under voltage condition is detected until the voltage regulator issues an alarm or shuts down excitation. A time value of 10.0 to 120.0 seconds may be entered in 0.1 second increments.

Over Excitation: Type – Two options can be selected from this pull down menu. “Inv Time” (for inverse curves) or “Threshold” (for a fixed time delay) can be selected. The voltage regulator disables excitation when an over excitation fault is detected unless a global “Shutdown Override” command is in effect.

Note: Selecting “Inv Time” requires changing the time setting to a suggested value of 2 (based on the time dial settings for the SR4B Generators curve). If this value is changed, over excitation protection may not exist.

Over Excitation: Trip Value (Amps) – This setting determines the level of field current that will cause an over excitation trip. Values of 0 to 12.0 amperes may be entered in 0.1 ampere increments. When in “Threshold” mode, the suggested value for the SR4 and SR4B generators is 12 amperes. When in “Inv Time” mode, the value entered should be determined by the full load excitation level of the generator and application. This entered value becomes a “per unit” value. For example, if a value of 12 is entered and a time setting of 2 is chosen, then 2.0 on the “Field Current” axis of the “Inverse Time” curve corresponds to 24 amps, that is, 2.0×12 . This will give the CDVR approximately 17 seconds before shutdown (provided the same level of current exists). If a trip value lower than the full load excitation level is entered, the CDVR will allow less time before shutdown for a given current level. **Excitation will be disabled instantly if the field current reaches 28 amps, regardless of the “Over Excitation” time setting. This event will indicate in the “Metering” screen as “Field Over Current” and is separate from the “Over Excitation” alarm.**

Over Excitation: Time Setting – This setting assigns the length of time from when an over excitation condition is detected and when the voltage regulator issues an alarm or shuts down the excitation. A time value of 1.0 to 10.0 seconds may be entered in 0.1 second increments. The required value for the SR4 and SR4B generators is 10 seconds. If “Inv Time” is selected, this value becomes the time dial setting for the generator. See Illustration 29.

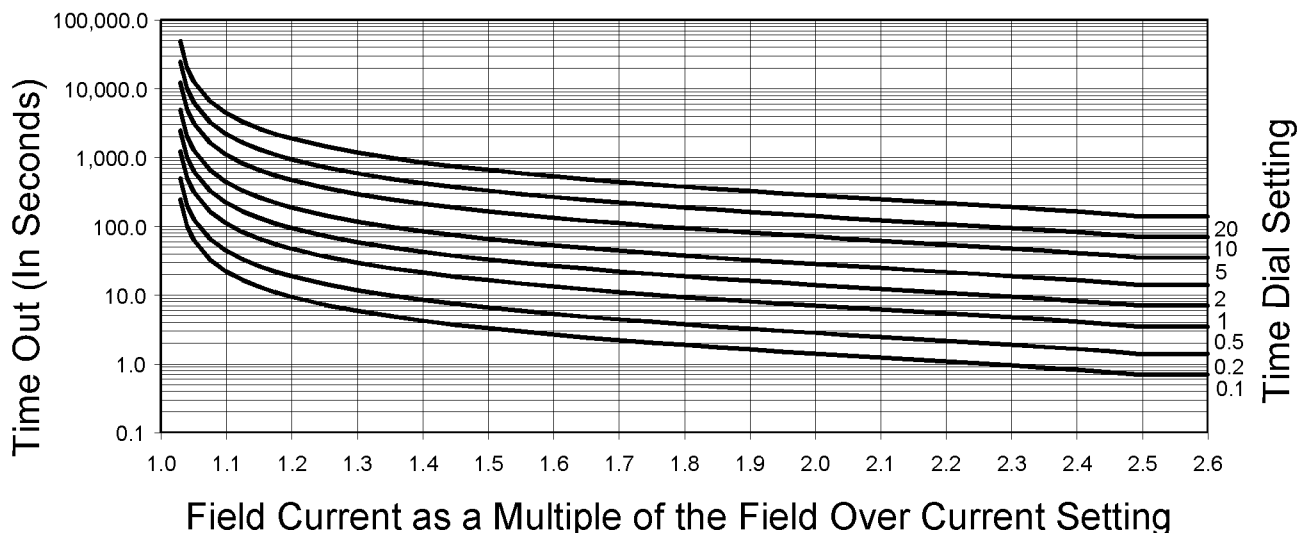

Illustration 29

g01119160

Inverse Time Characteristic for Over Excitation Limiter

Exciter Diode Monitor (EDM): Trip Value (Amps) –

This setting determines the level of current that is indicative of a failed exciter diode. The RMS ripple current of the field is measured. If the current level exceeds the diode fault threshold set point for five seconds, a diode fault is detected. The voltage regulator disables excitation when a diode fault is detected unless a global “Shutdown Override” command is in effect. A value of 1.0 to 10.0 amperes may be entered in 0.1 ampere increments. If the regulator shuts down on instantaneous “Field Over Current” of 28 amps or more, then the EDM alarm LED will not illuminate in the “Metering” screen.

Loss of Sensing (LOS): Time Delay (Secs) –

The value of this setting determines the time delay between the time a loss of sensing voltage is recognized and the time the voltage regulator responds by removing the field excitation. For single phase sensing, 50 percent of voltage set point is interpreted as an LOS. For three phase sensing, a total loss of one of the phases or an imbalance totaling 20 percent of the voltage set point is interpreted as an LOS. A time value of zero to 25.0 seconds may be entered in 0.1 second increments. The voltage regulator disables excitation when a loss of “Generator Sensing” fault is detected unless a global “Shutdown Override” command is in effect.

Fault Reset Too Long: Enabled – Selecting the “Enabled” check box enables the voltage regulator to issue an alarm or a shut down fault if the fault reset input is closed longer than 10 seconds.

Fault Reset Too Long: Fault Type – Two options can be selected from this pull down menu, “Alarm” or “Shutdown”. When “Alarm” is selected and the “Fault Reset” contact input remains closed for more than 10 seconds, the alarm output driver energizes, a J1939 alarm message is sent via the “CAN” communication port, and the “Fault LED” lights constantly. For units that are equipped with an RS-232 communication port, an alarm fault will be annunciated via the PC software. When “Shutdown” is selected and the “Fault Reset” contact input remains closed for more than 10 seconds, the “Fault Shutdown” output driver energizes, a J1939 alarm message is sent via the “CAN” communication port, and the “Fault LED” will flash. For units that are equipped with an RS-232 communication port, the voltage regulator will attempt to annunciate the “Shutdown” fault via the PC software. **The voltage regulator does NOT disable excitation when a “Fault Reset Closed Too Long” condition is detected.**

Metering, Operation, and Alarms

The “Metering, Operation, and Alarms” screen consists of a single tab labeled “Metering”. Click the “Metering” button to access the “Metering, Operation, and Alarms” screen or click “Screens” on the menu bar and click “Metering/Operation”.

Metering Tab

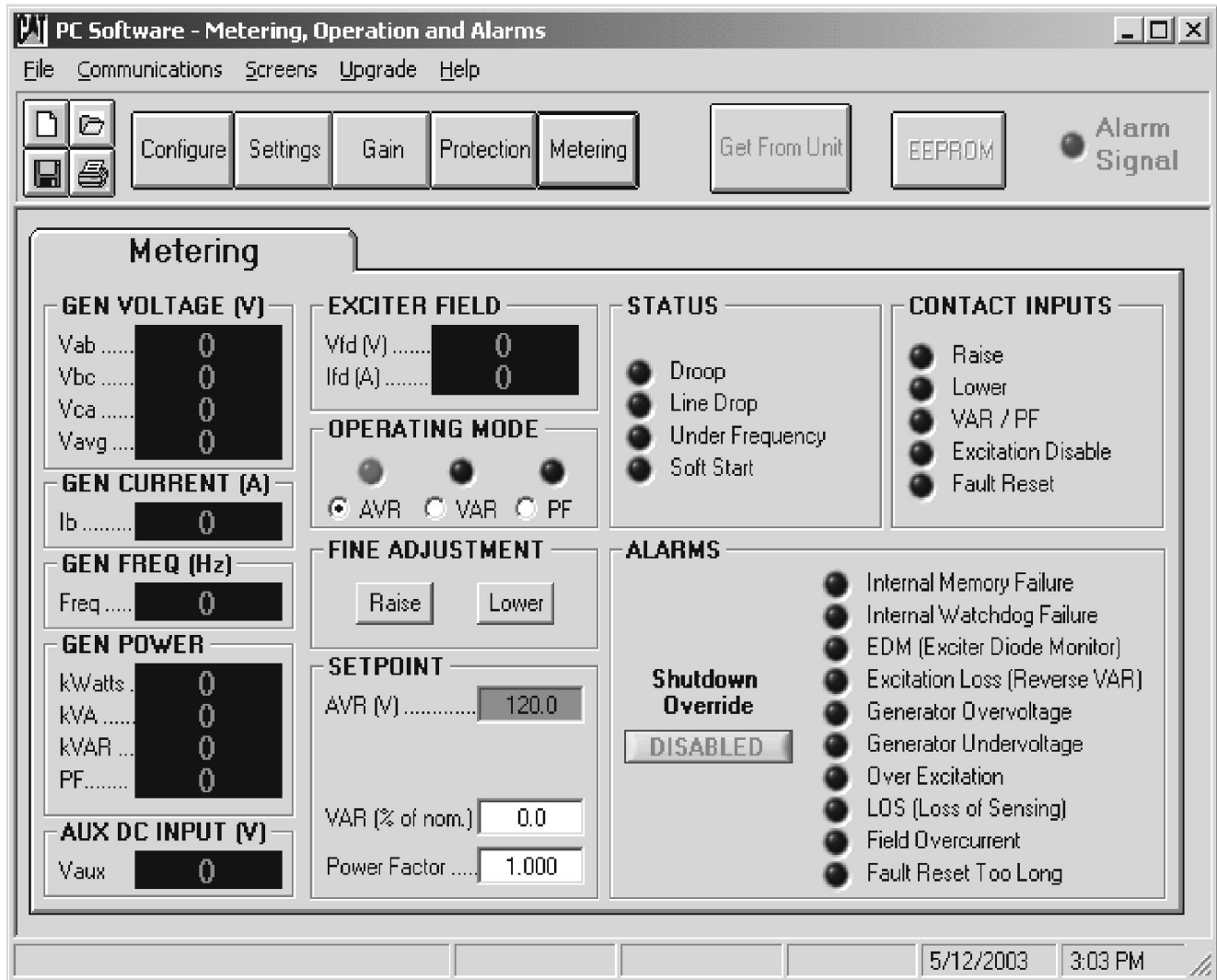

Illustration 30

g01010266

Note: When communication is established, a “Metering” choice becomes available in the menu bar. Metering can be disabled by selecting “Disable Metering” from this choice. When metering is disabled, contact inputs will still work normally, but will not indicate. “Alarms” will still work normally and indicate. The raise and lower buttons will still work and show a changed set point. If another tab is selected when metering is disabled, then the “Metering” tab is selected, metering will become enabled automatically.

GEN VOLTAGE (V): Vab – This field is a read-only field that displays the phase-to-phase voltage of phase A and phase B.

GEN VOLTAGE (V): Vbc – This field is a read-only field that displays the phase-to-phase voltage of phase B and phase C.

GEN VOLTAGE (V): Vca – This field is a read-only field that displays the phase-to-phase voltage of phase C and phase A.

GEN VOLTAGE (V): Vavg – This field is a read-only field that displays the average value of the three phase-to-phase voltages.

GEN CURRENT (A): Ib – This field is a read-only field that displays the value of the current on the B phase of the generator.

GEN FREQ (Hz): Freq – This field is a read-only field that displays the value of the frequency of the generator voltage.

GEN POWER: kWatts – This field is a read-only field that displays the value of real power that is being output from the generator.

GEN POWER: kVA – This field is a read-only field that displays the value of apparent power that is being output by the generator.

GEN POWER: kVAR – This field is a read-only field that displays the value of reactive power that is being output by the generator.

GEN POWER: PF – This field is a read-only field that displays the value of the power factor that the generator is operating at.

AUX DC INPUT (V): Vaux – This field is a read-only field that displays the level of dc control voltage that is applied from a remote device to the voltage regulator terminals “P12-3” (B) and “P12-6” (A).

Note: The “Aux DC Input” terminals can be used as an alternate method of adjusting voltage in “AVR” mode or adjusting PF or VAR in PF or VAR mode when used with an existing remote VAR/PF controller. A DC input on these pins acts as a DC bias. When the CDVR is in “AVR” mode, a 1 VDC change on the terminals corresponds to a 1 percent change in the voltage set point. A 1 VDC change gives a 10 percent VAR change (in “VAR” mode) and a 0.04 PF change (in “PF” mode). If the DC voltage is removed from the ± 10 VDC control input, the operating set point will return to the original value regardless of pressing the EEPROM button.

Note: Adding a DC voltage when the operating set point is near the voltage adjust band limit may allow the regulator to operate outside of the voltage adjust band.

EXCITER FIELD: Vfd (V) – This field is a “read-only” field that displays the value of the exciter field voltage.

EXCITER FIELD: Ifd (A) – This field is a “read-only” field that displays the value of the exciter field current.

OPERATING MODE – One of three operating modes may be selected as active: “AVR”, “VAR”, or “PF”. When an operating mode is active, the corresponding indicator color changes from black to red for “AVR” mode. When an operating mode is active, the corresponding indicator color changes from black to green for the “VAR” mode and the “PF” mode.

Note: When either KVAR or PF mode are selected, the appropriate button must be selected and the auxiliary breaker contact that is connected to “P9-6” (KVAR/PF enable contact) and “P9-9” (contact sense common) must be closed.

Note: “Droop” should be enabled whenever the CDVR is operated in PF or VAR mode. The newest version of the CDVR PC firmware will not allow the operator to select PF or VAR mode unless “Droop” is selected in the “Settings” menu first. The “Droop” setting can be set to 0 percent.

FINE ADJUSTMENT – The “Raise” and “Lower” buttons control the fine adjustment of the operating set point. These buttons perform the same function as closing the appropriate set of contacts connected to the “Contact Sense – Raise” input (terminal P9-5) and “Contact Sense - Lower” input (terminal P9-4) of the voltage regulator. Each click of the “Raise” button increases the voltage set point by 0.1 V, each click of the “Lower” button decreases the voltage set point by 0.1 V.

Note: The PT ratio will affect this setting.

Note: An alternate method of adjusting voltage is to adjust the DC voltage between terminals “P12-3” and “P12-6”.

SET POINT: AVR (V) – This setting field is used to enter the desired generator terminal voltage. The background color of this field is green when the voltage regulator is in AVR mode.

Note: The PT ratio will affect this setting.

SET POINT: VAR (percent of nom.) – This setting determines the level of generator VARs maintained by the voltage regulator when operating in VAR mode. The background color of this field is green when the voltage regulator is regulating the VAR set point. A percentage value of zero to 100.0 may be entered in 0.1 percent increments.

SET POINT: Power Factor – This setting determines the level of power factor regulation maintained by the voltage regulator. The background color of this field is green when the voltage regulator is regulating the power factor set point. A power factor value of -0.600 to 0.600 may be entered in 0.001 increments.

STATUS – Four indicators indicate the operating status of the voltage regulator: “Droop”, “Line Drop”, “Under Frequency”, and “Soft Start”.

The “Droop” indicator turns red when the “Reactive Droop Compensation” feature is selected. The “Reactive Droop Compensation” feature is used during parallel generator operation to assist in the sharing of reactive load.

The “Line Drop” indicator turns red when the “Line Drop Compensation” feature is selected. The “Line Drop Compensation” feature is used to compensate for voltage drops in the lines between the generator and the load.

The “Under Frequency” indicator turns red when the generator frequency decreases below the “Knee Frequency” setting and excitation is terminated.

The “Soft Start” indicator turns red when the “Soft Start” feature is active to control the time for generator voltage to ramp up during startup.

CONTACT INPUTS – Five indicators provide the status of the voltage regulator switch inputs: “Raise”, “Lower”, “VAR / PF”, “Excitation Disable”, and “Fault Reset”.

The “Raise” indicator turns red when contact closure at terminals “P9-5” “Contact Sense - Raise” and “P9-6” “Contact Sense - Common” is detected.

The “Lower” indicator turns red when contact closure at terminals “P9-4” “Contact Sense - Lower” and “P9-6” “Contact Sense - Common” is detected.

The “Var/PF” indicator turns red when contact closure at terminals “P9-9” “Contact Sense - Var/PF Enable” and “P9-6” “Contact Sense - Common” is detected.

The “Excitation Disable” indicator turns red when contact closure at terminals “P9-7” “Contact Sense – Excitation Disable” and “P9-6” “Contact Sense - Common” is detected.

The “Fault Reset” indicator turns red when contact closure at terminals “P9-8” “Contact Sense - Fault Reset” and “P9-6” “Contact Sense - Common” is detected.

ALARMS – Ten indicators annunciate alarm conditions. Alarm indicators include the following alarms: “Internal Memory Failure”, “Internal Watchdog Failure”, “Exciter Diode Monitor”, “Excitation Loss”, “Generator Over voltage”, “Generator Undervoltage”, “Over excitation”, “Loss of Sensing”, “Field Over current (28 Amps instantaneous shutdown)”, and “Fault Reset Too Long”. When the voltage regulator detects an alarm condition, the appropriate indicator changes from black to red.

ALARMS: Shutdown Override Status – This indication provides the status (position) of the “Shutdown Override Button”. The button displays “ENABLED” when selected and “DISABLED” when deselected.

The CDVR does some diagnostic code logging and diagnostic code broadcasting. These codes are transmitted over CANbus. When the CDVR is operating, any active diagnostic codes will be transmitted along with a description of that code and the occurrence count.

If power is removed from the CDVR, the nonvolatile memory will retain the following information for each of the 10 alarms if any codes have been logged:

- code
- description
- service meter hours first
- service meter hours last
- real time clock first
- real time clock last
- occurrence count

Note: The CDVR does not know the actual time. The CDVR only knows the elapsed time from CDVR power up.

Settings Files

Caterpillar PC software enables you to print a list of voltage regulator settings, save voltage regulator settings in a file, and open a settings file in order to upload those settings to a voltage regulator. A settings file may also be opened and edited with any text editing software.

Printing the Settings Files

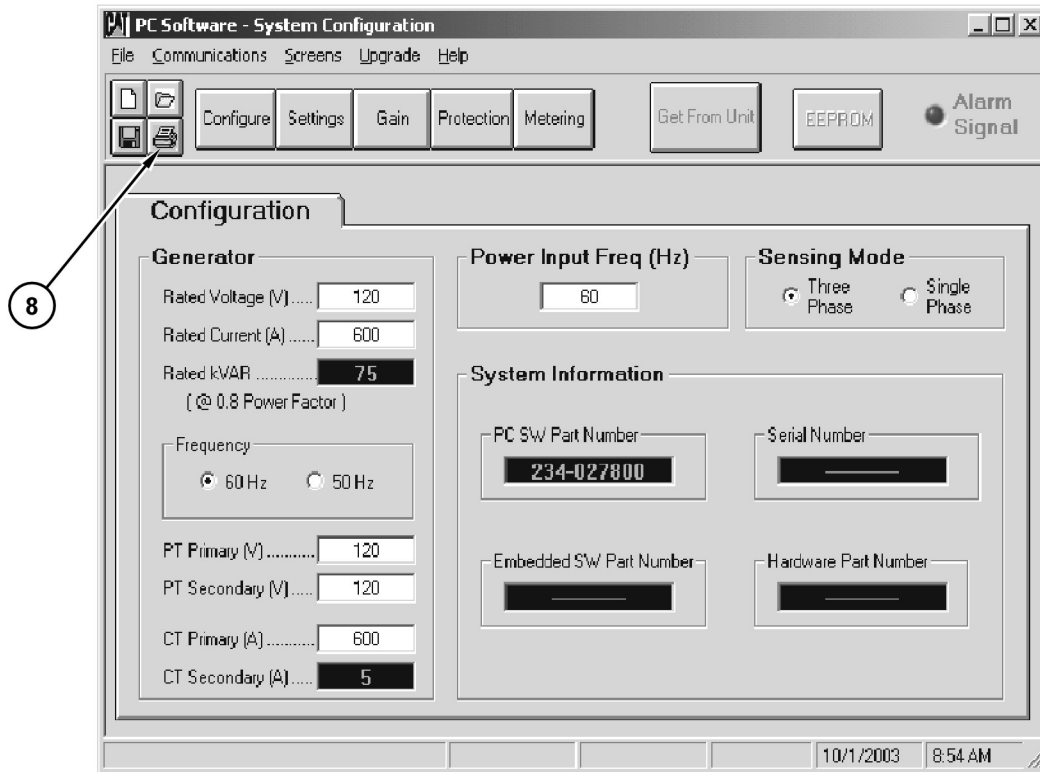

Illustration 31
Print Icon

g01394300

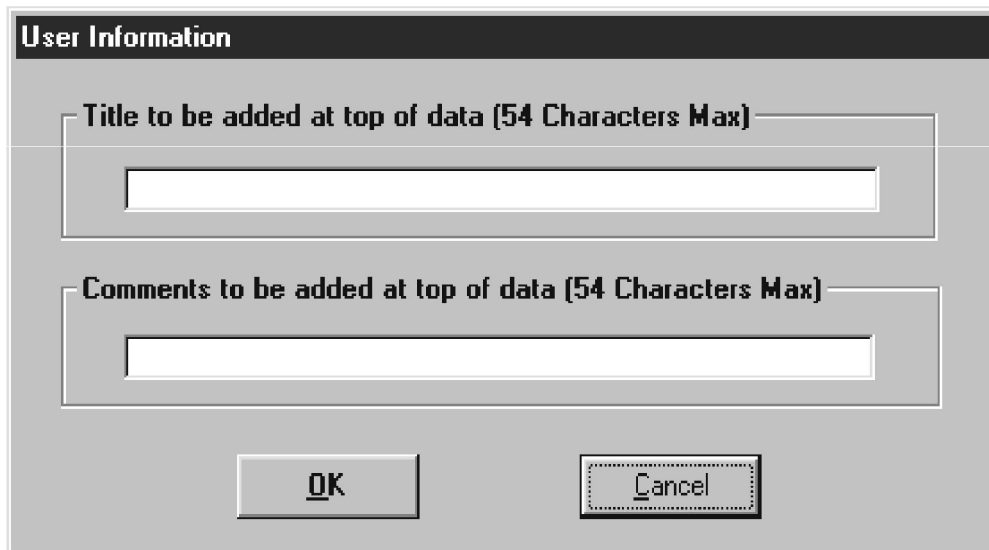

Illustration 32

g01016740

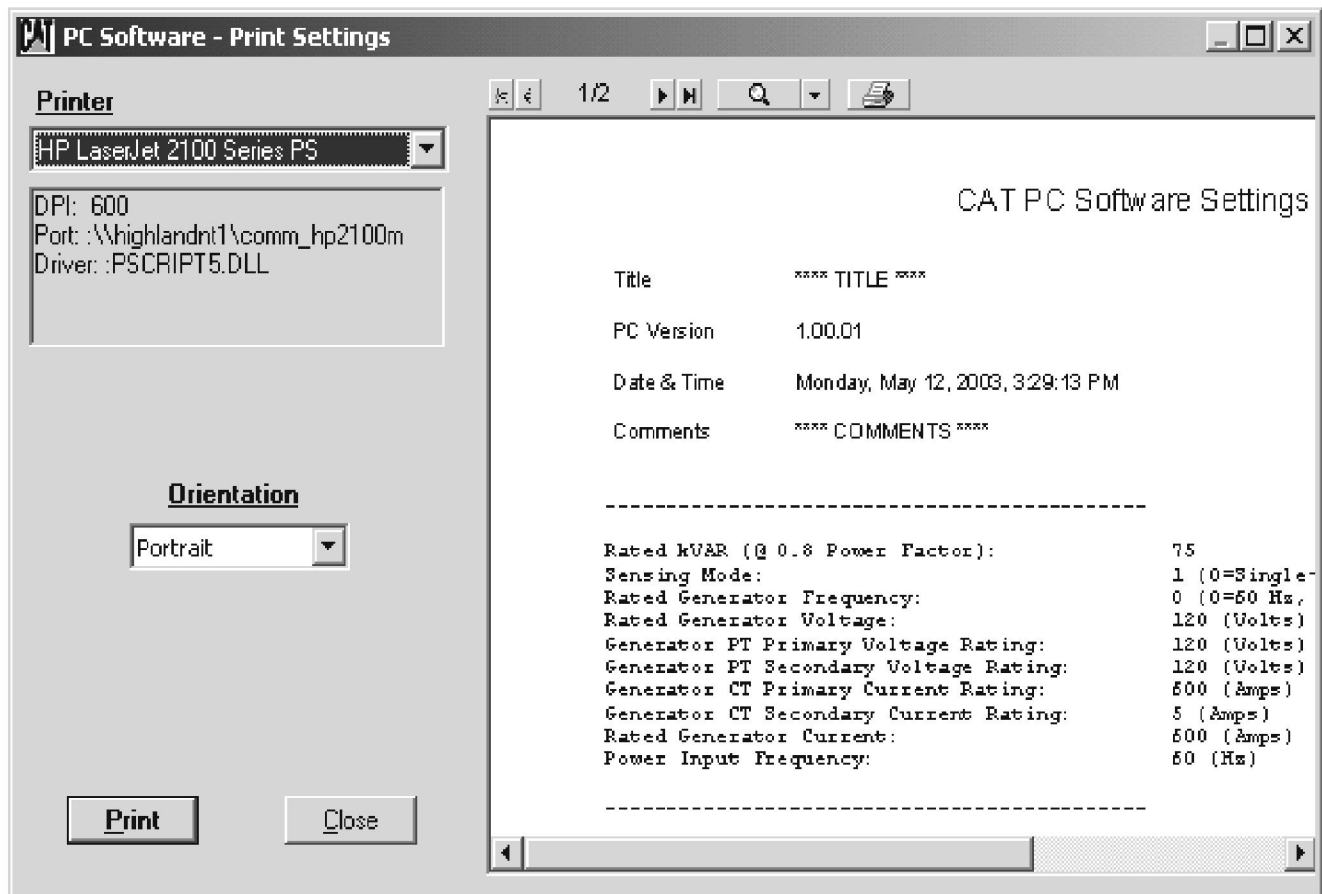

Illustration 33

g01016741

A printout of voltage regulator settings can be useful for record keeping or comparison purposes. The voltage regulator settings can be printed by clicking the print icon (1) or clicking "File" on the menu bar and then clicking "Print". When the print command is given, a dialog box provides the opportunity to add a title and comments to the settings list. See illustration 32. Each entry is limited to a maximum of 54 characters. After this information is entered, click on "OK". The "Print Settings" box will appear. See illustration 33. This dialog box is used in order to select the desired printer, change and verify the printer settings, and preview the printed settings list. Click on the "Print" button in order to print the settings list.

Saving the Settings Files

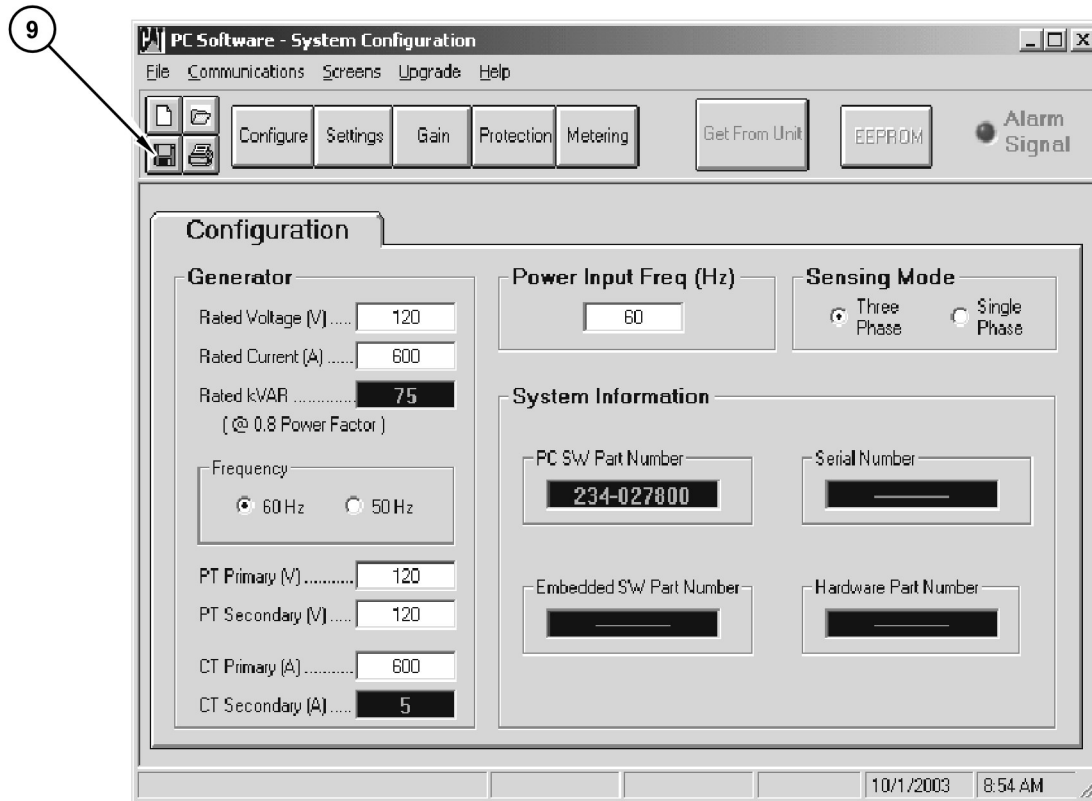

Illustration 34
Save Icon

g01394035

It is recommended that the settings for the voltage regulator be saved to a file. In order to save setup time when configuring multiple units with the same settings, the saved settings can be uploaded to other voltage regulator units.

A settings file can also be created in the PC software without being connected to a voltage regulator. The settings of the desired screens can be changed. The settings can then be saved to a file. Once a settings file is created, the file can be edited with the use of any text editing software. The file can then be saved for uploading.

A settings file is created by clicking the save icon (1) or by clicking “File” on the menu bar and then clicking “Save”. When the command is given, a “Save As” dialog box is displayed where the settings are assigned a file name and then saved. All voltage regulator settings files are automatically given a “.dv2” extension.

Uploading the Settings Files to the Voltage Regulator

A voltage regulator settings file downloaded from a voltage regulator or created within the PC software can be uploaded to multiple voltage regulator units. Only a voltage regulator settings file with a “.dv2” extension can be uploaded to a voltage regulator unit. Before uploading a file, communication must be initiated with the voltage regulator that is to receive the settings. See Systems Operation, “Remote Communication”.

The upload process is started by clicking the open icon or clicking “File” on the menu bar and then clicking “Open”. An “Open” dialog box is then displayed where the desired settings file is navigated to and selected. Clicking “Open” uploads the settings file. The default settings for the CDVR are stored in a file called “Defaults.DV2” in the “CDVR PC Software” folder on the PC.

The defaults are displayed here for reference.

Table 10

CDVR PC Software Settings	
Rated kVAR (@ 0.8 Power Factor):	75
Sensing Mode:	1 (0=Single-Phase, 1=Three-Phase)
Rated Generator Frequency:	0 (0=60 Hz, 1=50 Hz)
Rated Generator Voltage:	120 (Volts)
Generator PT Primary Voltage Rating:	120 (Volts)
Generator PT Secondary Voltage Rating:	120 (Volts)
Generator CT Primary Current Rating:	600 (Amps)
Generator CT Secondary Current Rating:	5 (Amps)
Rated Generator Current:	600 (Amps)
Power Input Frequency:	60 (Hz)
Load Compensation Mode:	0 (0=Off, 1=Droop, 2=Line Drop)
Operating Mode:	2 (0=AVR[Off], 1=PF, 2=VAR)
AVR Setpoint:	120.0 (Volts)
AVR Minimum Setpoint:	102.0 (Volts)
AVR Maximum Setpoint:	138.0 (Volts)
VAR Setpoint:	0.0 (%)
PF Setpoint:	1
AVR Voltage Control:	0 (0=CAN Input, 1=Switch)
VAR/PF Control:	1 (0=CAN Input, 1=Switch)
Soft Start Bias:	10.00 (%)
Soft Start Time:	5.00 (Seconds)
Knee Frequency:	50.00 (Hz)
Decreasing Slope 1:	2.00 (Volts/Hz)
Minimum Voltage:	50.00 (% of rated)
Frequency Deviation from Knee Frequency:	5.00 (Hz)
Decreasing Slope #2:	2.00 (Volts/Hz)
Minimum Frequency:	25.00 (Hz)
AVR Proportional Gain:	200
AVR Integral Gain:	600
AVR Derivative Gain:	30
Noise Filter Time Constant:	0.00 (Seconds)
Regulator Loop Gain:	50
Pre-defined PID Gains:	21 (1-20 or Custom)
Voltage Adjustment Band Limit:	15.00 (% of rated)

(continued)

(Table 10, contd)

Overexcitation Type:	0 (0=Threshold, 1=Inverse Time)
Overexcitation Trip Value:	12.0 (Amps)
Overexcitation Time Setting:	10
Excitation Loss (Reverse VAR):	1 (0=Disabled, 1=Enabled)
Excitation Loss (Reverse VAR) Fault Type:	0 (0=Alarm, 1=Shutdown)
Excitation Loss (Reverse VAR) Trip Value:	10 (%) ⁽¹⁾
Excitation Loss (Reverse VAR) Time Delay:	3 (Seconds) ⁽¹⁾
Generator Overvoltage:	1 (0=Disabled, 1=Enabled)
Generator Overvoltage Fault Type:	0 (0=Alarm, 1=Shutdown)
Generator Overvoltage Trip Value:	135 (%)
Generator Overvoltage Time Delay:	2.0 (Seconds)
Generator Undervoltage:	1 (0=Disabled, 1=Enabled)
Generator Undervoltage Fault Type:	0 (0=Alarm, 1=Shutdown)
Generator Undervoltage Trip Value:	60 (%)
Generator Undervoltage Time Delay:	30.0 (Seconds)
Loss of Sensing Time Delay:	2.0 (Seconds)
Exciter Diode Monitor Trip Value:	2.0 (Amps)
Fault Reset Too Long:	1 (0=Disabled, 1=Enabled)
Fault Reset Too Long Fault Type:	0 (0=Alarm, 1=Shutdown)
Shutdown Override Flag:	0 (0=Disabled, 1=Enabled)
VAR Integral Gain:	5
VAR Loop Gain:	2.5
PF Integral Gain:	5
PF Loop Gain:	3

⁽¹⁾ The default settings for software 279 - 0916 Generator Set Software Gp and before are 40 (%) and 0.5 (Seconds).

Uploading Embedded Firmware Using the CDVR PC Software

Embedded firmware is the operating program that controls the actions of the CDVR. The CDVR stores firmware in nonvolatile flash memory that can be reprogrammed through the RS-232 communication port. It is not necessary to replace EPROM chips when replacing the firmware with a newer version.

NOTICE

If power is lost or communication is interrupted during file transfer, the CDVR will not recover and will cease to be operational.

Note: Communication must be closed prior to uploading embedded firmware to the CDVR. Refer to the “Terminating Communication” section for information about closing CDVR communication.

In order to flash the CDVR, the following materials are needed:

- CDVR
- CDVR PC software
- Firmware as a .s19 file
- Computer with communication port

- A “pass through” 1U-9484 Cable or equivalent RS-232 “pass through” cable with one end that has a male connector and the other cable end with a female connector
- 24 V power to the CDVR

Flash the CDVR

1. Apply power to the CDVR.
2. Connect a communication cable between the RS-232 connector (J4) of the CDVR and the appropriate communication port of your PC.
3. Start the CDVR PC software.
4. Click “Upgrade” on the “Menu” bar. Click “Upload Embedded Software”. Refer to Illustration 35. If this menu selection is grayed out, close CDVR communication. Refer to the “Terminating Communication” section for information about closing CDVR communication.

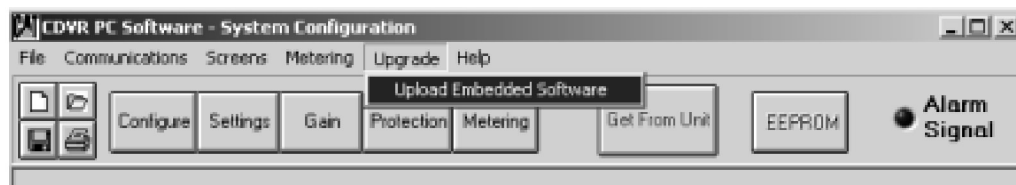

Illustration 35

g01408125

Upload Embedded Software

5. When “Upload Embedded Software” is clicked, a dialog box appears and verifies your intent to update the firmware. Click “Yes” to proceed. When “Yes” is clicked, the “CDVR Embedded Program Loader” screen will appear. Refer to Illustration 36.

Note: Uploading firmware may replace some user adjusted settings with factory default settings.

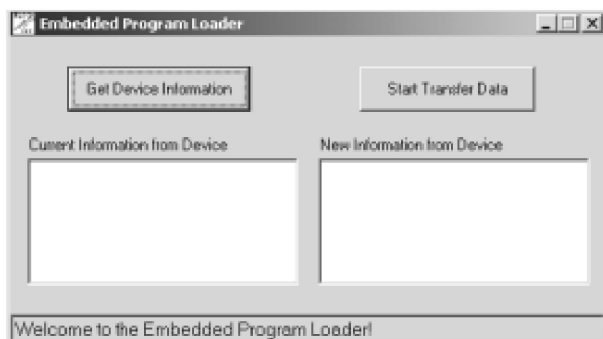

Illustration 36

g01408128

6. Click the “Get Device Information” button. The “CDVR Embedded Program Loader” will retrieve and will display the CDVR model number. The information will be displayed in the left hand column as shown in Illustration 37.

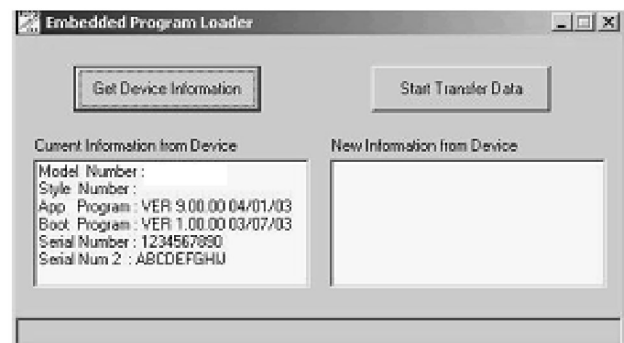

Illustration 37

g01408132

7. Click the “Start Transfer Data” button in order to proceed with software uploading. Illustration 38 will appear. Illustration 38 recommends that the CDVR settings be saved in a file that can be uploaded to the CDVR after the embedded firmware is updated.

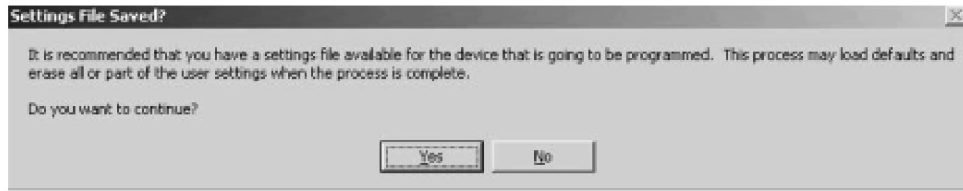

Illustration 38

g01408133

8. Click “No” in order to exit the upload process and in order to create a CDVR settings file. Refer to the “Settings Files” section for information about creating a settings file. Click “Yes” in order to continue with the upload process and in order to display the “Open” dialog box that is shown in Illustration 39. The “Open” dialog box is used in order to locate and select the appropriate file for uploading to the CDVR. Only files with the .s19 extension are displayed in the “Open” dialog box.

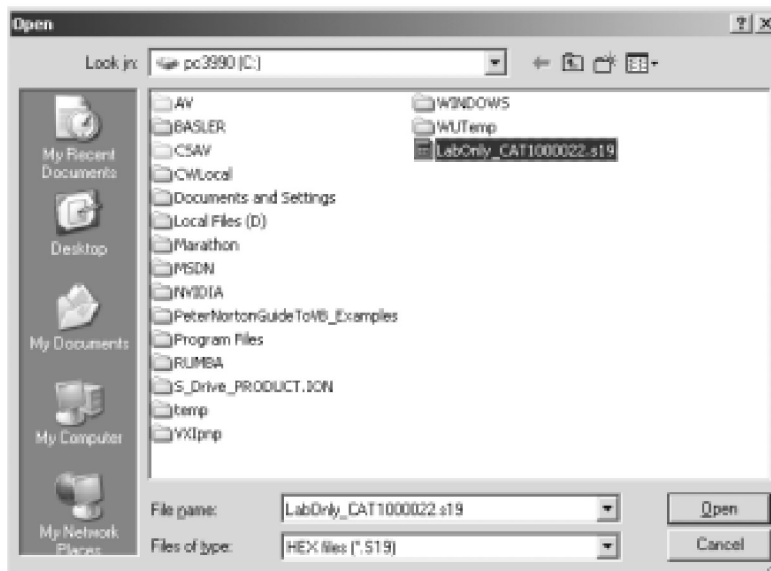

Illustration 39

g01408135

9. Select the appropriate file for uploading. Click the “Open” button in order to start the file transfer. If the dialog box appears that is shown in Illustration 40, then software is asking for the serial number of the CDVR. Enter the eight (8) numerical digits of the serial number exactly as they appear on the upper right hand corner of the label on the CDVR. Ignore the letters GD. **Do not use the CDVR serial number that is shown in the PC software. Do not use spaces, dashes, or any other symbols.** Press “Enter”.

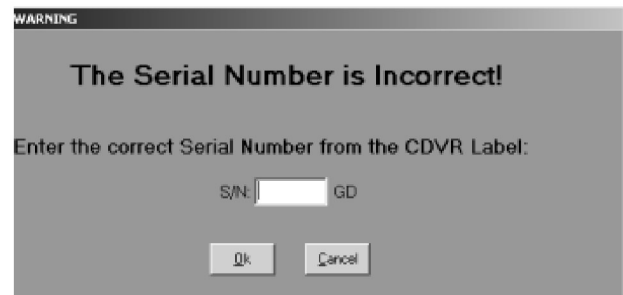

Illustration 40
Serial Number Change

g01408137

10. A dialog box will appear in order to indicate the progress of the file transfer. Refer to Illustration 41.

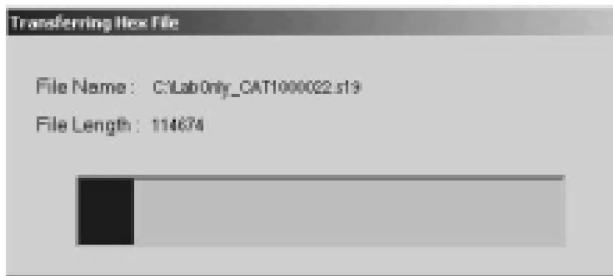

Illustration 41

g01408138

11. Once the transfer is complete, the device information is displayed in the right hand column of the “Embedded Program Loader”. Refer to Illustration 42. The displayed program version number indicates the version and the date of the firmware that was just loaded.

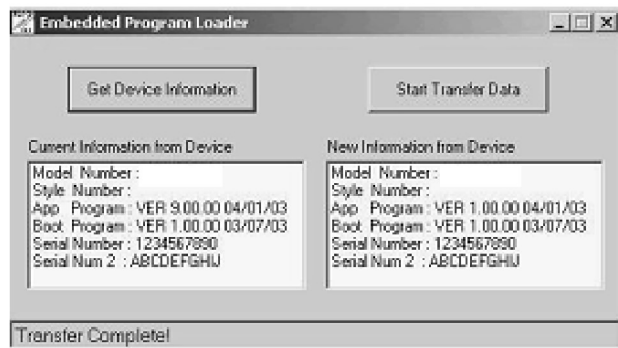

Illustration 42

g01408140

CDVR Information After Upload

12. Close the “Embedded Program Loader”. The default settings are loaded into the CDVR and are checked.

If desired, the settings can be reloaded into the regulator from the saved settings file. Refer to the “Settings Files” section for information about loading a settings file.

Flash the CDVR Using Cat ET Software

The following items are needed in order to flash the CDVR with Cat ET:

- CDVR
- Caterpillar Electronic Technician software (Cat ET)

- Power to the CDVR
- Computer with a serial port
- Communication Adapter II (171 -4400 Communication Adapter Group)

Follow the steps below to flash the CDVR with Cat ET:

1. Follow steps 1 through 6 in the “Parameter Viewing and Configuration-Caterpillar Electronic Technician” section.
2. Disconnect communication if necessary.
3. Click on the “Flash Memory” button. Refer to Illustration 43.

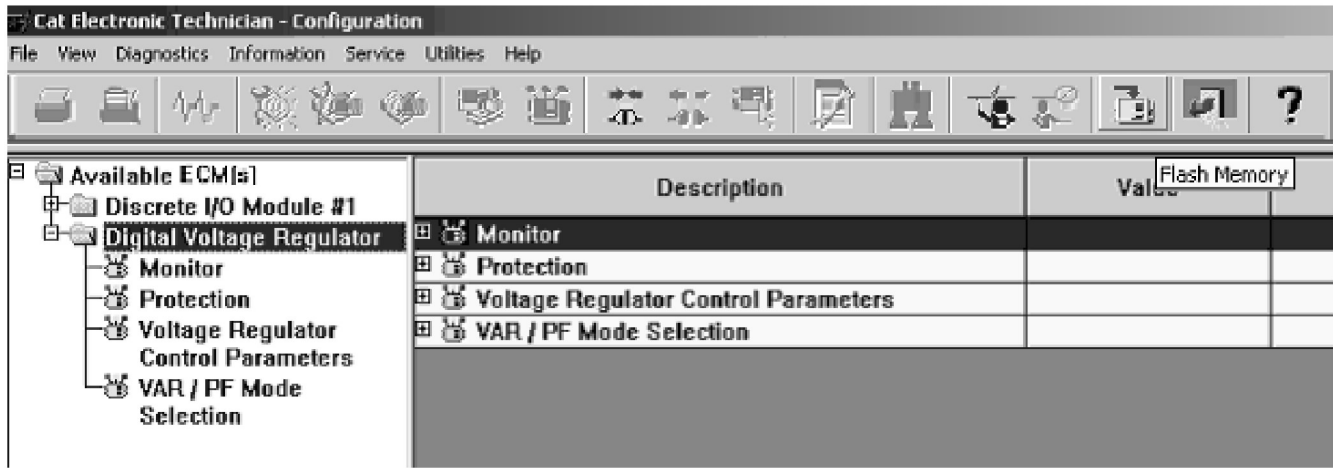

Illustration 43

g01425391

4. The “WinFlash” screen will appear. Refer to Illustration 44.

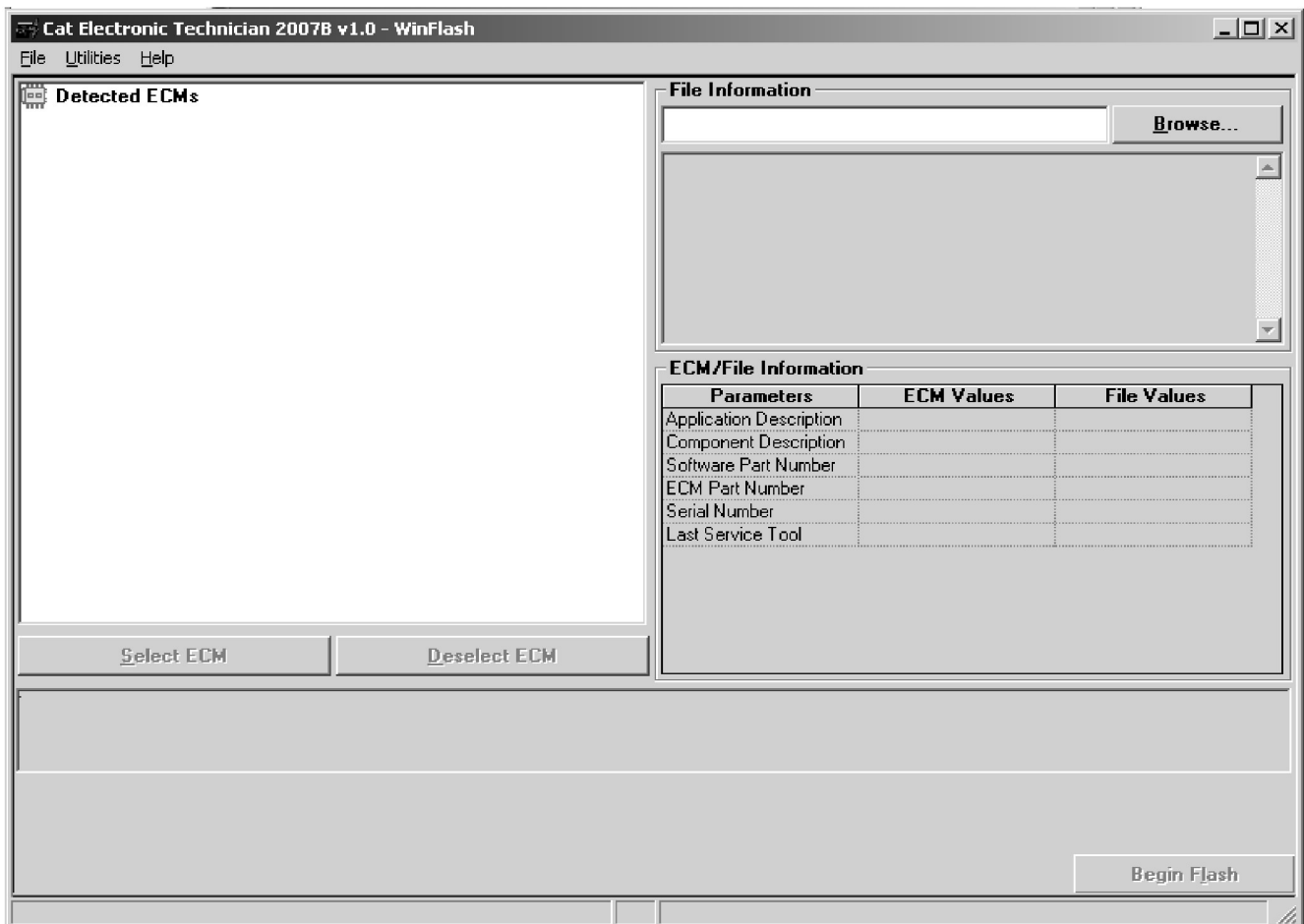

Illustration 44

g01425392

5. Select the CDVR in the list. Click “Browse” that is located in the upper right corner of the screen. Browse to the appropriate .fls file. Select “Open”.
6. When the “Winflash” screen appears, select “Begin Flash” in order to flash the selected file into the CDVR. “Begin Flash” is located in the lower right corner of the screen.

i02848566

Parameter Viewing and Configuration (Caterpillar Electronic Technician)

SMCS Code: 4467-NQ

The following materials are needed to program the voltage regulator with Cat ET:

- CDVR
- Cat ET Software
- 24 VDC control power to the voltage regulator
- IBM compatible PC with serial port, 486DX2 or faster (100 MHz or higher microprocessor is recommended)
- Communication Adapter II

Follow the steps below in order to program the voltage regulator with Cat ET:

1. Apply 24 VDC control power to the voltage regulator.
2. Connect the “Communication Adapter II” module between the computer and the primary “CANbus” port and start the Cat ET software. Select the appropriate communication port, if prompted.



Illustration 45

g01112515

ECM's detected screen

3. Wait for the software to recognize the ECM's. See illustration 45.

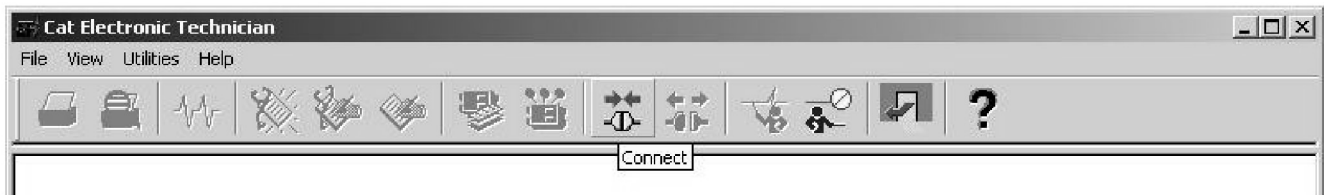

Illustration 46
Connect button

g01112560

- If the software does not automatically connect, click on the "CONNECT" button at the top of the screen as shown in illustration 46.

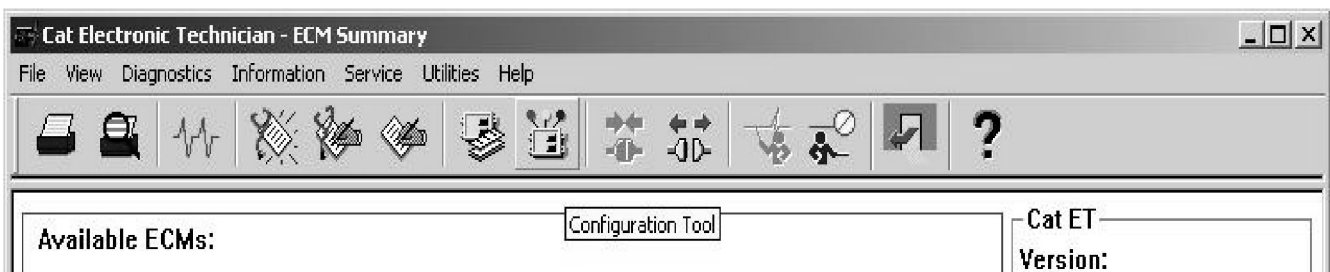

Illustration 47
Configuration tool

g01113063

- The "Service" menu contains a drop down menu containing the "Configuration Tool" button as shown in illustration 47. Click on the "Configuration Tool" button. Select the CDVR from the list by clicking on it once.

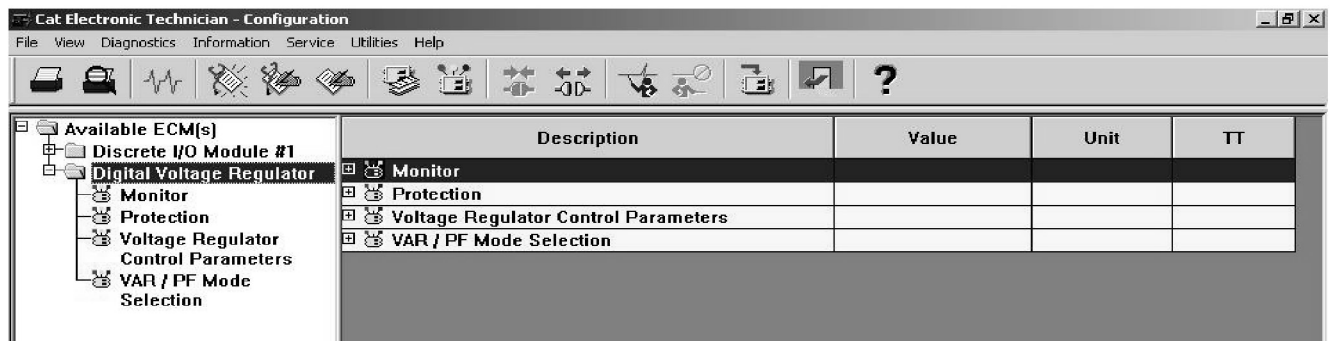

Illustration 48
Available ECM's

g01113076

6. Verify that the CDVR is listed in the left panel under “AVAILABLE ECM(S)” as shown in illustration 48.

The screenshot shows the 'Cat Electronic Technician - Configuration' window. The left panel displays a tree view under 'Available ECM(s)' with 'Discrete I/O Module #1' expanded to show 'Digital Voltage Regulator'. The right panel shows a table of configuration parameters for the Digital Voltage Regulator.

Description	Value	Unit	TT
Generator Connection Configuration	Three Phase		
Generator Rated Frequency	60 Hz		
Generator Rated Voltage	120	Volts	
Generator Rated Current	600	Amps	
Voltage Regulator Loss of Sensing Shutdown Event Notification Delay Time	2.0	Sec	
Generator Rotating Diode Monitor Shutdown Event Current Threshold	2.0	Amps	

Illustration 49
Configuration group

g01113082

7. Select the configuration group that is to be viewed by clicking on the group in the left panel. Refer to illustration 49. If necessary, expand the CDVR folder in the left panel by clicking the “+” symbol next to the CDVR label. The various parameters to be programmed or viewed in that particular configuration group become visible in the right panel.

The screenshot shows the 'Cat Electronic Technician - Configuration' window. The left panel displays a tree view under 'Available ECM(s)' with 'Discrete I/O Module #1' expanded to show 'Digital Voltage Regulator'. The right panel shows a table of configuration parameters for the Digital Voltage Regulator, with the 'Voltage Regulator Loss of Sensing Shutdown Event Notification Delay Time' parameter highlighted.

Description	Value	Unit	TT
Generator Connection Configuration	Three Phase		
Generator Rated Frequency	60 Hz		
Generator Rated Voltage	120	Volts	
Generator Rated Current	600	Amps	
Voltage Regulator Loss of Sensing Shutdown Event Notification Delay Time	2.0	Sec	
Generator Rotating Diode Monitor Shutdown Event Current Threshold	2.0	Amps	
Generator Reverse VAR Shutdown Event Percentage Threshold	40	%	
Generator Reverse VAR Shutdown Event Notification Delay Time	0.5	Sec	

Illustration 50
Parameter selection

g01113121

8. In order to program a parameter, double click that parameter in the right panel or highlight the parameter by single clicking the parameter, then press “ENTER”. Refer to illustration 50.

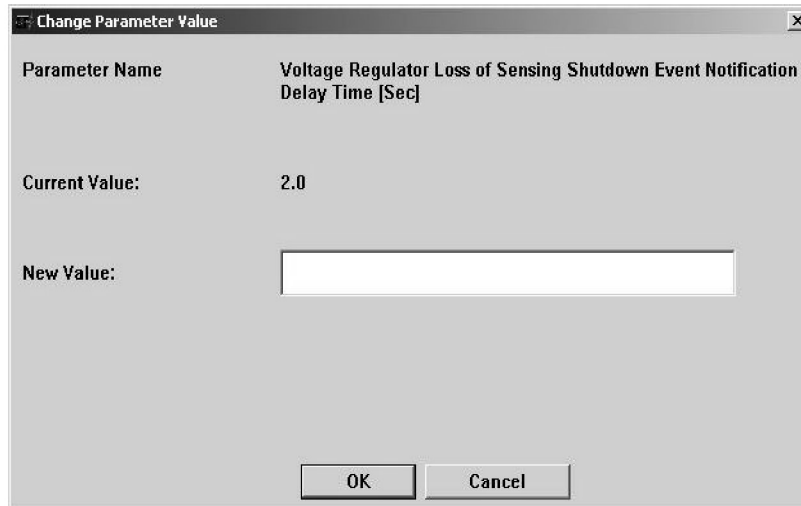

Illustration 51
Change Parameter Value

g01113102

9. Type the new value or select a new value from the drop down menu if the “CHANGE PARAMETER VALUE” window is available. Click on “OK”. Click on “YES” in order to confirm. Refer to illustration 51.
10. Repeat steps 7 through 9 for each parameter to be programmed.



Illustration 52
Disconnect button

g01113109

11. In order to disconnect communication, click the “DISCONNECT” button. Refer to Illustration 52.

Viewing Metering Parameters Using Cat ET Software

The following items are needed to view metering parameters in the CDVR with Cat ET:

- CDVR

- Caterpillar Electronic Technician software (Cat ET)
- Power to the CDVR
- Computer with serial port
- Communication Adapter II (171 -4400 Communication Adapter Group)

Follow the steps below in order to view metering parameters in the CDVR with Cat ET.

i02847372

1. Follow steps 1 through 6 in “Parameter Viewing and Configuration - Caterpillar Electronic Technician” section.
2. Click on the “Status Tool” button in order to view the metering parameters. Refer to Illustration 53.

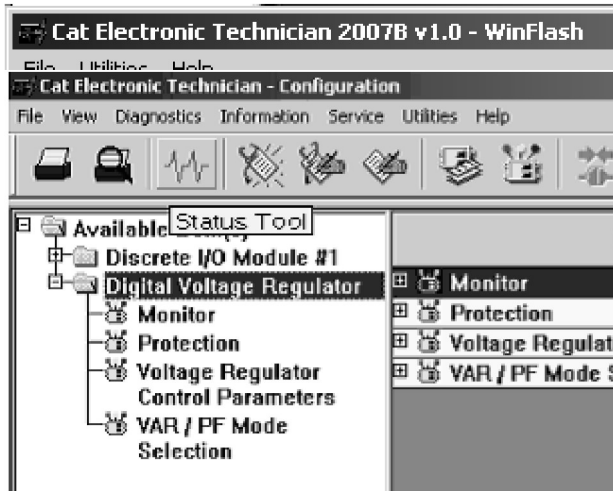

Illustration 53

g01425537

3. Various status groups will be available. Refer to Illustration 54. Click on a status group in order to display the parameters in that group.

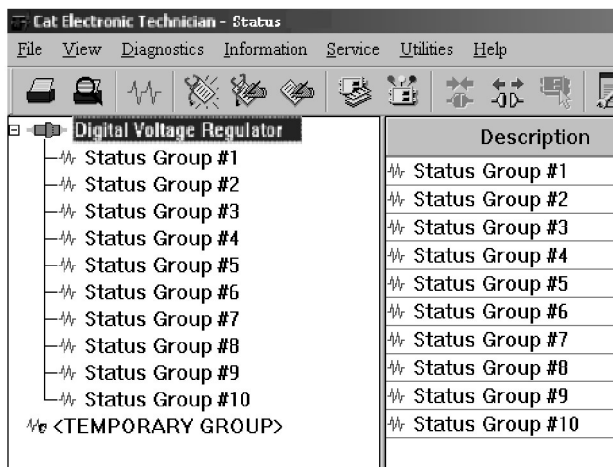

Illustration 54

g01425538

4. In order to set up custom groups, double click on “Temporary Group”. Double click on the parameters that are desired in order to add them to the group.
5. Click “OK” again to enable the group.

Gain Setting - Adjust

SMCS Code: 4467

The following steps should only to be used as a guide if the default settings in the CDVR do not give acceptable performance. Each generator has its own requirements that are application specific.

1. Starting with the factory defaults ($K_p = 200$, $K_i = 600$, $T_d = 0$, and $K_g = 50$), adjust K_g to achieve the desired response. If that response is not achievable, proceed to Step 2.
2. Perform a “step of reference” test by recording the generator terminal voltage with a chart recorder or similar device. Limit the step sizes to 5% or less of terminal voltage, that is, from 480V to 504V.
 - a. If the response is too slow, increase K_i .
 - b. If the response is oscillatory or has a large amount of overshoot, decrease K_i or K_d .
 - c. If the desired response is still not achievable, proceed to Step 3.
3. If $T'do$ and T_e are known, use the PID calculator in order to obtain the starting PID values. If $T'do$ is known but T_e is not known, use the PID calculator with the default exciter time constant ($T_e = T'do/6$). If the desired response is not obtainable with these PID values, proceed to Step 4.
4. Start with $K_p = 10$, $K_i = 2$, $K_d = 2$, $T_d = 0$, and $K_g = 30$. If the voltage set point is not achieved, increase K_g until the machine terminal voltage is approximately equal to the set value. Reduce K_i to 0.01. The terminal voltage should decrease. Adjust K_g in order to obtain 90% of set terminal voltage, for example, if the voltage set point is 480V, adjust K_g to achieve 432V.
5. With K_g set as determined in Step 4, set $K_p = 40$, $K_i = 10$, $K_d = 10$, and $T_d = 0$. Perform a “step of reference” test, with no more than 5% per step, for example, from 480V to 504V. Adjust K_p to achieve 80% of the final value (403V in the example) in the desired time frame.

The desired rise time should be based on how fast you want the combined generator and CDVR to respond. In most application, this will be in the range of 0.5 seconds to 1 second. Once K_p is adjusted, increase K_i in order to get the desired response. If overshoot or if ringing occurs, reduce K_i and then increase K_p , K_i , and K_d . Keep the ratio constant.

Note: Many people use a load application or rejection test in order to adjust the voltage regulator. If available, use an inductive load. A resistive load is not the best way to adjust the voltage regulator's PID values. If the only load available is a resistive load, beware that the engine governor's or speed governor's response will significantly affect the voltage regulator's performance.

i02848548

Troubleshooting

SMCS Code: 4467

If the voltage regulator does not operate as expected, first check the programmable settings for the appropriate function. Use the following troubleshooting procedures when difficulties are encountered in the operation of the excitation system.

Alarm or Shutdown Faults

Faults that are discussed in this section will not cause excitation to be turned off unless some external means of removing excitation is wired into the "Alarm" output driver or is wired into the "Shutdown Fault" output driver. Shutdown faults that always cause excitation to be turned off are discussed in the Testing and Adjusting, "No Voltage - Troubleshoot" section. Open communication with the voltage regulator in order to determine which fault condition has occurred.

If the "Fault" LED is lit constantly, this indicates that the "Alarm" output driver is active. If the Fault LED is flashing, this indicates that the "Shutdown" output driver is active.

If an "Excitation Loss" (reverse VAR) fault has occurred, a reverse VAR condition has been detected in excess of the programmed threshold for longer than the programmed time delay. If an incorrect fault detection is suspected, verify that the programmed settings are compatible with the application. If settings are correct, it is possible to get an incorrect fault detection if the generator voltage and the generator current sensing inputs to the voltage regulator are not properly wired for ABC rotation. Verify correct wiring of the generator voltage and generator current sensing inputs to the voltage regulator. Refer to the Testing and Adjusting, "Wiring Diagrams" section.

If a "Generator Overvoltage" fault has occurred, a generator overvoltage condition has been detected at the generator voltage sensing input(s) of the voltage regulator in excess of the programmed threshold for longer than the programmed time delay. Refer to the Testing and Adjusting, "High Voltage - Troubleshoot" section.

If a "Generator Undervoltage" fault has occurred, a generator undervoltage condition has been detected at the generator voltage sensing input(s) of the voltage regulator in excess of the programmed threshold for longer than the programmed time delay. Refer to the Testing and Adjusting, "Low Voltage - Troubleshoot" section.

If the "Fault Reset" contact input is closed for more than 10 seconds, a "Fault Reset Too Long" fault has occurred. Remove the short across the "Fault Reset" contact input.

Resetting the voltage regulator may be achieved either by momentarily closing the "Fault Reset" contact input or by cycling the 24 VDC control power.

i02822506

No Voltage - Troubleshoot

SMCS Code: 4467-035



Illustration 55

g01425620

⚠ DANGER

The Cat Digital Voltage Regulator presents an electrical shock/electrocution hazard. This hazard will cause serious injury or death.

Service by trained personnel only.

The terminals and heat sinks are live at hazardous voltages when power is applied and for up to 8 minutes after power is removed.

1. Verify that all of the wiring is properly connected. Refer to Testing and Adjusting, "Wiring Diagrams".

OK – If the wiring connections are correct, go to step 2.

NOT OK – If the wiring is improperly connected or the wiring is loose, reconnect the wiring properly.

STOP.

2. Verify that the generator is running at rated speed.

OK – If the generator is spinning at rated speed, go to step 3.

NOT OK – If the generator is not at rated speed, increase generator speed to the rated value.

STOP.

3. The digital voltage regulator is PMG power or Shunt powered.

PMG power – Proceed to step 4.

Shunt Powered – Proceed to step 5.

4. Check for correct input power to the voltage regulator. Refer to Specification, “Electrical”, for input power requirements.

OK – If voltage is present, go to step 5.

NOT OK – If PMG voltage is not present, refer to the generator manual for the repair procedures and check for an open circuit.

STOP.

5. Verify that the residual voltage applied to the power input is at least 6 VAC.

OK – If the applied voltage is 6 VAC or greater, go to step 6.

NOT OK – If the applied voltage is less than 6 VAC, refer to the generator manual and flash the generator field. Install blocking diodes in series with the battery in order to prevent damage to the voltage regulator and/or the battery.

STOP.

6. Verify that the fuse is not open.

OK – If no fuses are open, go to step 8.

NOT OK – Replace any fuses that are open.

STOP.

7. Verify that the CDVR is connected to 24VDC control power.

OK – If CDVR is connected to 24VDC control power, go to step 8.

NOT OK – Connect CDVR to 24VDC control power.

STOP.

8. Verify that the common alarm/Shutdown LED indicator on the voltage regulator is not flashing.

OK – If no protective fault has caused the excitation to be turned off, go to step 15.

NOT OK – If the LED indicator is flashing, open communications with the voltage regulator to determine if a protective shutdown fault has occurred that would cause excitation to be turned off. If protective shutdown fault has occurred that would cause excitation to be turned off, go to step 9.

9. If an Exciter Diode Monitor (EDM) fault has occurred, stop the machine, insure that the power input to the voltage regulator is removed, and unplug “P6” on the voltage regulator.

a. Refer to the generator manual for instructions on checking the rotating exciter diodes. Have the rotating exciter diode assembly checked for open or shorted diodes. If an open or shorted diode is present in the rotating exciter diode assembly, refer to the generator manual for instructions on how to replace the rotating rectifier assembly.

b. After repairs are complete, reset the voltage regulator by momentarily closing the Fault Reset contact or by cycling 24 VDC control power.

c. The generator may be restarted. If there is no problem with the rotating exciter diode assembly, the EDM trip value may be set too low. An EDM fault may occur with good rotating exciter diodes under varying loads if the trip level is set too low. Set the EDM trip level to a value greater than the RMS ripple current present in the exciter field under normal operating conditions in order to prevent a false trip.

d. Reconnect “P6”. Reset the voltage regulator by momentarily closing the Fault Reset contact or by cycling 24 VDC control power.

e. The generator may be restarted. If an Exciter Diode Monitor (EDM) fault has not occurred, go to step 10.

10. If an Over Excitation fault has occurred, stop the machine and have the generator and/or load conditions checked for a generator or load fault that could cause excessive exciter field current to flow. Also have the system checked for loose or open connections to the voltage regulator sensing inputs. Any faults must be repaired.

- a. After repairs are complete, reset the voltage regulator by momentarily closing the Fault Reset contact or by cycling 24 VDC control power.
- b. The generator may be restarted. If no generator or load fault has occurred and there are no loose or open connections to the sensing inputs of the voltage regulator, verify that the Over Excitation trip level and the delay settings are properly adjusted for the generator.
- c. Set the Over Excitation trip level slightly above the requirement of the application but not so high as to render the protection ineffective or damage the system.
- d. Reset the voltage regulator by momentarily closing the Fault Reset contact or by cycling 24 VDC control power.
- e. The generator may be restarted. If the Over Excitation fault still exists, the instantaneous trip value of 28 Amperes may have been reached by a faulty diode. The EDM virtual fault LED will not indicate in this case since there is a 5 second delay associated with the EDM fault protection. Go to Step 9. If an Over Excitation fault has not occurred, go to step 11.

Note: SR4 and SR4B generators may require up to 12 Amperes for full load excitation. A 10 second delay is needed in order to insure 300 percent short circuit current requirements.

11. If a Loss of Sensing fault has occurred, stop the machine and have the system checked for loose or open connections to the voltage sensing inputs of the voltage regulator.
 - a. Have the generator and/or load conditions checked for a generator or load fault that could cause the sensed voltage to be low.
 - b. If the generator is equipped with voltage transformers for stepping the generator voltage down to levels usable by the voltage regulator, verify that the transformers are functional and that any transformer fuses are not open.
 - c. If transformer fuses are found to be open, replace the fuses.
 - d. Any faults must be repaired. After repairs are complete, reset the voltage regulator by momentarily closing the Fault Reset contact or by cycling 24 VDC control power.
 - e. The generator may be restarted. If a Loss of Sensing fault has not occurred, go to step 12.

12. If a Field Overcurrent fault has occurred, stop the machine and have the generator and/or load conditions checked for a generator or load fault that could cause excessive exciter field current to flow. Also have the system checked for loose or open connections to the voltage regulator sensing inputs. A Field Overcurrent fault is detected when output current from the voltage regulator exceeds approximately 28 A.

OK – If a Field Overcurrent fault has not occurred, go to step 13.

NOT OK – Any fault must be repaired. After repairs are complete, reset the voltage regulator by momentarily closing the Fault Reset contact or by cycling 24 VDC control power. The generator may be restarted.

STOP.

13. If an Internal Memory Failure fault has occurred, try resetting the voltage regulator by momentarily closing the Fault Reset contact or by cycling 24 VDC control power.

STOP. – If an Internal Memory fault has not occurred, go to step 14.

NOT OK – If after resetting the voltage regulator another Internal Memory Failure occurs, replace the voltage regulator.

STOP.

14. If an Internal Watchdog Failure fault has occurred, reset the voltage regulator by momentarily closing the Fault Reset contact or by cycling 24 volt control power.

OK – If an Internal Watchdog Failure fault has not occurred, go to step 15.

NOT OK – If after resetting the voltage regulator another Internal Watchdog Failure fault occurs, replace the voltage regulator.

STOP.

15. Replace the voltage regulator unit. If replacing the voltage regulator unit does not correct the problem, go to step 16.
16. There is a problem with the generator. Refer to the generator manual to troubleshoot the problem.

i02847657

Low Voltage - Troubleshoot

SMCS Code: 4467-035

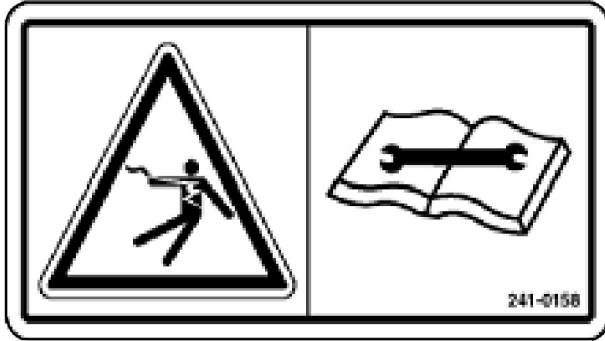

Illustration 56

g01425622

⚠ DANGER

The Cat Digital Voltage Regulator presents an electrical shock/electrocution hazard. This hazard will cause serious injury or death.

Service by trained personnel only.

The terminals and heat sinks are live at hazardous voltages when power is applied and for up to 8 minutes after power is removed.

1. Verify that the voltage adjustment is not set too low.

OK – If the voltage adjustment is correct, go to step 2.

NOT OK – If the voltage adjustment is too low, adjust the voltage to the correct setpoint.

STOP.
2. Verify that the underfrequency setpoint (knee frequency) is not greater than the generator frequency.

OK – If the underfrequency setpoint is correct, go to step 3.

NOT OK – If the underfrequency setpoint is too high, adjust the setpoint below the rated generator frequency.

STOP.
3. Verify that the generator is running at rated speed.

OK – If the generator is running at rated speed, go to step 5.

NOT OK – If the generator is not at rated speed, increase the generator speed to the rated level.

STOP.

4. PMG power or Shunt powered regulator

PMG power – Proceed to step 5.

Shunt powered – Proceed to step 6.

5. Check for the correct input power to the voltage regulator. Refer to Specification, "Electrical" for input power requirements.

OK – If the voltage is at the required level, go to step 7.

NOT OK – If the voltage regulator input voltage is low, refer to the generator manual for PMG repair.

STOP.

6. Verify that the potential transformer (if used) has the correct turns ratio and is supplying the correct voltage to the power input.

OK – If the turns ratio of the power potential transformer is correct, go to step 7.

NOT OK – If the turns ratio of the potential transformer is incorrect, is sized too small, or the transformer is not supplying the correct power, replace the potential transformer.

STOP.

7. Verify that the sensing potential transformer (if used) has the correct turns ratio and is operating correctly.

OK – If the sensing potential transformer is operating correctly, go to step 8.

NOT OK – If the turns ratio of the sensing potential transformer is incorrect, replace the sensing potential transformer.

STOP.

8. Low generator output voltage may occur when operating in droop mode with an inductive load. If the low voltage condition is not caused by the droop function, go to step 9.

9. Replace the voltage regulator.

i02847591

High Voltage - Troubleshoot

SMCS Code: 4467-035

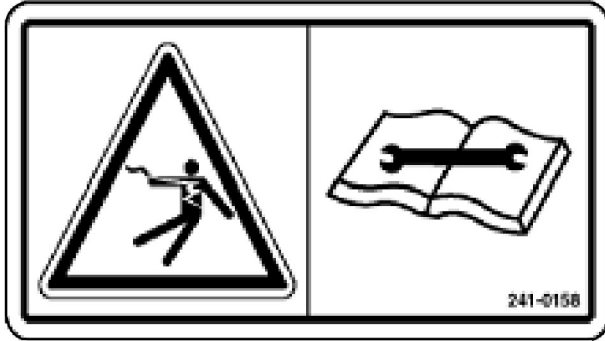

Illustration 57

g01425625

DANGER

The Cat Digital Voltage Regulator presents an electrical shock/electrocution hazard. This hazard will cause serious injury or death.

Service by trained personnel only.

The terminals and heat sinks are live at hazardous voltages when power is applied and for up to 8 minutes after power is removed.

1. Verify that the voltage adjustment is not set too high.

OK – If the voltage adjustment is correct, go to step 2.

NOT OK – If the voltage adjustment is too high, adjust the voltage to the correct set point.

STOP.

2. Verify that the sensing potential transformer (if used) has the correct turns ratio.

OK – If the sensing potential transformer is correct, go to step 3.

NOT OK – If the turns ratio of the sensing potential transformer is incorrect, replace the sensing potential transformer with the correct one.

STOP.

3. High generator output voltage may occur when operating in droop mode with a capacitive load. If the high voltage condition is not caused by the droop function, go to step 4.

4. High generator output voltage may occur when operating in line drop compensation mode with a large generator load. If the high voltage condition is not caused by the line drop compensation function, go to step 5.

5. Verify that the fuses for the sensing potential transformer (if used) are not open.

OK – If the fuses for the sensing potential transformer are correct, go to step 6.

NOT OK – If the fuses for the sensing potential transformer are open, replace the fuses.

STOP.

6. Verify that the auxiliary input voltage going to the voltage regulator is present or abnormally high. Higher than normal voltage at this input will cause a higher than normal generator voltage. If voltage is present on the auxiliary input, remove the input by removing the wiring going to the voltage regulator. If the wire is removed and the generator voltage returns to the desired level, investigate where the voltage is coming from, possible a VAR/PF controller or another source of control. If the auxiliary input voltage is not present or abnormally high, go to step 7.

7. Replace the voltage regulator.

i02848556

Unstable Voltage - Troubleshoot

SMCS Code: 4467-035

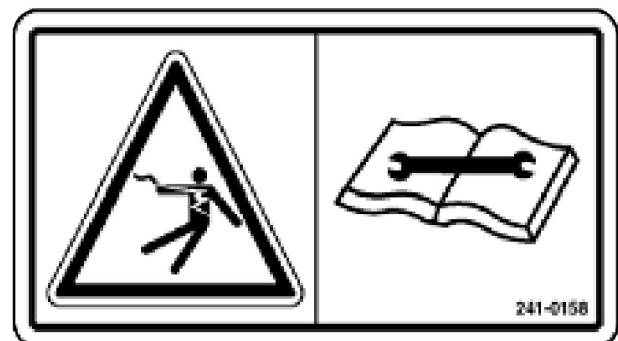

Illustration 58

g01425628

⚠ DANGER

The Cat Digital Voltage Regulator presents an electrical shock/electrocution hazard. This hazard will cause serious injury or death.

Service by trained personnel only.

The terminals and heat sinks are live at hazardous voltages when power is applied and for up to 8 minutes after power is removed.

1. Verify that the governor for the engine is operating properly.

OK – If the governor is operating properly, go to step 2.

NOT OK – If the governor is not operating properly, refer to the engine manual in order to troubleshoot the problem.

STOP.

2. Verify that the sensing and input power leads are connected securely.

OK – If the sensing or input power lead connections are secure, go to step 3.

NOT OK – If the sensing or input power leads are not connected securely, tighten the connections.

STOP.

3. Verify that the voltage regulator stability range is set to the proper range.

OK – If the stability range setting is correct, go to step 4.

NOT OK – If the stability range setting is incorrect, reset the stability range.

STOP.

4. Verify that the stability level is properly set. If the stability level is not properly set, reset the stability level.

i02826583

Generator Overcurrent - Troubleshoot

SMCS Code: 4467-035

1. Verify that the PTs are installed correctly.

2. Is there a difference between sensed voltage and rated voltage, that is, the voltage that is sensed off of the wye center tap?

OK – If yes, go to Step 3.

NOT OK – If no, go to Step 4.

3. Verify the following parameters are programmed as follows:

- Rated voltage (V) equals the generator rated voltage
- PT primary (V) equals the generator winding rated voltage
- PT secondary (V) equals the generator sensed voltage

Go to step 5.

4. Verify the following parameters are programmed as follows:

- Rated voltage (V) equals the generator rated voltage
- PT primary (V) equals the generator rated voltage
- PT secondary (V) equals the generator rated voltage

Go to step 5.

5. Verify that the field winding inputs to the CDVR are not partially or completely shorted.

OK – If winding inputs are ok, go to Step 6.

NOT OK – If winding inputs not ok, repair winding input fault. Check the system again.

STOP.

6. Check exciter for proper resistance value.

OK – If exciter resistance value is ok, go to Step 7.

NOT OK – If exciter resistance value is not ok, repair exciter fault. Check the system again.

STOP.

7. If all of the previous steps fail to correct the malfunction, replace the voltage regulator.

STOP.

i02847363

Reverse VAR Condition - Troubleshoot

SMCS Code: 4467-035

The switchgear or the generator set control panel will initiate "Reverse Var Tripping".

1. Operate the generator in "Stand-Alone" mode.
2. Start the CDVR PC software, establish communication, and then go to the "Metering" screen.
3. Apply a small reactive load.
4. Check the kWatts and Kvar values in the "Metering" screen.
5. If both kWatts and Kvar are negative, the CT may be wired backwards. Check the wiring to the CT. Alternately, the "A" and "C" sensing leads may be reversed. Physically check the connections from the bus bars to the sensing inputs for correct ordering (12-10, 12-11, and 12-12 are C-B-A respectively).
6. If either kWatts or Kvar is negative, and the other is positive, the "A" and "B", or "B" and "C" sensing leads may be reversed. Physically check the connections from the bus bars to the sensing inputs for correct ordering (12-10, 12-11, and 12-12 are C-B-A respectively).

i02847685

Poor Voltage Regulation - Troubleshoot

SMCS Code: 4467-035

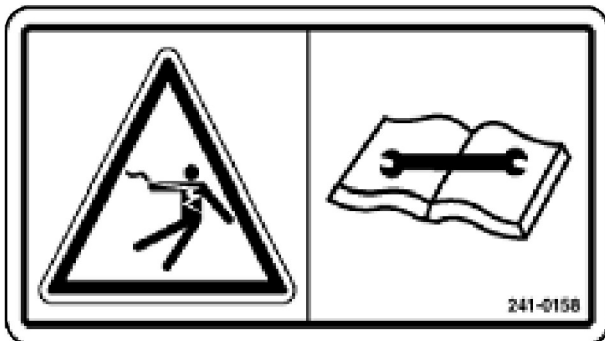

Illustration 59

g01425632

DANGER

The Cat Digital Voltage Regulator presents an electrical shock/electrocution hazard. This hazard will cause serious injury or death.

Service by trained personnel only.

The terminals and heat sinks are live at hazardous voltages when power is applied and for up to 8 minutes after power is removed.

1. Verify that the chassis of the voltage regulator is properly grounded.
OK – If the voltage regulator is properly grounded, go to step 2.
NOT OK – If the voltage regulator is not properly grounded, connect a dedicated ground wire to terminal P6-6 on the voltage regulator.
STOP.
2. Check for grounded field leads.
OK – If the field leads are not grounded, go to step 3.
NOT OK – If the field leads are grounded, isolate the field leads from ground.
STOP.
3. Check for grounded PMG leads.
OK – If the PMG leads are not grounded, go to step 4.
NOT OK – If the PMG leads are grounded, isolate the PMG leads from ground.
STOP.
4. Verify that the generator frequency is not dropping below the voltage regulator underfrequency setpoint when load is applied to the generator.
OK – If poor regulation is not related to voltage regulator underfrequency operation, go to step 5.
NOT OK – If the generator frequency is dropping below the underfrequency setpoint, reduce the setpoint if possible. Also check the engine and generator for proper sizing in relation to the applied load.
STOP.

Note: Measure the PMG voltage from line to line.

5. Verify that regulation is not being affected by normal droop operation. If droop operation is not affecting regulation, go to step 6.
6. Verify that regulation is not being affected by normal line loss compensation. If line loss compensation is not affecting regulation, replace the voltage regulator.

On new applications and when commissioning, check the PID value. If voltage fluctuates at steady state No Load or Full Load, reduce Kg or if at 1.0 reduce Kp. Recalculate PID in calculator.????? Need to check with Ryan if N.L. and F.L. are what I think it is. Sent him an email 9/13/07.

Note: Self Excited (shunt powered) generators will have a greater input power voltage than PMG generators. This will require a lower gain settings (Kg first then Kp if necessary) on comparably sized machine. Adjust Kg values first, then Kp values to reach acceptable steady-state and transient responses.

i02847675

No Line Loss Compensation - Troubleshoot

SMCS Code: 4467-035

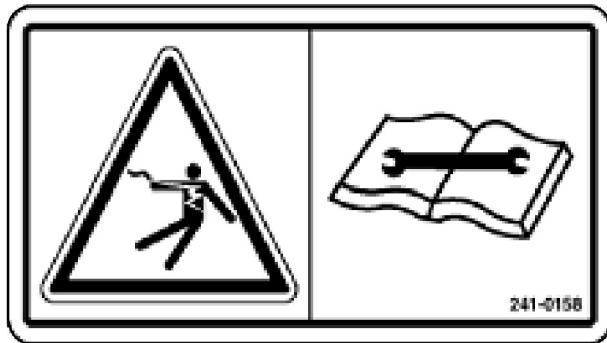

Illustration 60

g01425633

⚠ DANGER

The Cat Digital Voltage Regulator presents an electrical shock/electrocution hazard. This hazard will cause serious injury or death.

Service by trained personnel only.

The terminals and heat sinks are live at hazardous voltages when power is applied and for up to 8 minutes after power is removed.

1. Verify that the voltage regulator is programmed for line loss compensation. If the voltage regulator is programmed for line loss compensation, go to step 2.
2. Verify that the voltage regulator line drop setting is not adjusted to 0%. If the line drop setting is adjusted to 0%, increase the set point above 0%. If the line drop setting is adjusted to above 0%, go to step 3.
3. Check for an open in the circuit connected to voltage regulator terminals P12-1 and P12-2 and CT2. If there is an open circuit, repair as necessary. If there is not an open circuit, go to step 4.
4. Verify that all connections are correct according to Testing and Adjusting, "Wiring Diagrams". If connections are incorrect, correct the problem. If connections are correct, go to step 5.
5. Verify that the load that is being applied to the generator for droop testing is not a purely resistive load. If only a resistive load is being applied to the generator, apply an inductive load and retest. If the load being applied to the generator is inductive, go to step 6.
6. Verify that the current sensing transformer that is being used is compatible with the voltage regulator. For example, a current sensing transformer with a 1 ampere output rating would produce very little droop since the voltage regulator has a 5 ampere current transformer input. If the current transformer input is incorrect, replace the current sensing transformer for compatibility. If the current transformer input is correct, go to step 7.
7. If all of the previous steps fail to correct the malfunction, replace the voltage regulator.

i02822626

No Voltage Droop - Troubleshoot

SMCS Code: 4467-035



Illustration 61

g01425634

DANGER

The Cat Digital Voltage Regulator presents an electrical shock/electrocution hazard. This hazard will cause serious injury or death.

Service by trained personnel only.

The terminals and heat sinks are live at hazardous voltages when power is applied and for up to 8 minutes after power is removed.

1. Verify that the voltage regulator is programmed for droop mode. If the voltage regulator is programmed for droop mode, go to step 2.
2. Verify that the voltage regulator droop setting is not adjusted to 0% droop. If the droop setting is adjusted to 0% droop, increase the setpoint above 0%. If the droop setting is adjusted to above 0%, go to step 3.
3. Check for an open in the circuit connected to voltage regulator terminals P12-1 and P12-2 and CT2. If there is an open circuit, repair as necessary. If there is not an open circuit, go to step 4.
4. Verify that all connections are correct according to Testing and Adjusting, "Wiring Diagrams". Verify that the "Current Transformer" (CT) is not installed backwards, or on the wrong phase. Verify that the "Potential Transformer" (PT) phase rotation is correct. If connections and installations are correct, go to step 5.
5. Verify that the load that is being applied to the generator for droop testing is not a purely resistive load. If only a resistive load is being applied to the generator, apply an inductive load and retest. If the load being applied to the generator is inductive, go to step 6.
6. Verify that the current sensing transformer that is being used is compatible with the voltage regulator. For example, a current sensing transformer with a 1-ampere output rating would produce very little droop since the voltage regulator has a 5 ampere current transformer input. If the current transformer input is incorrect, replace the current sensing transformer for compatibility. If the current transformer input is correct, go to step 7.
7. If all of the previous steps fail to correct the malfunction, replace the voltage regulator.

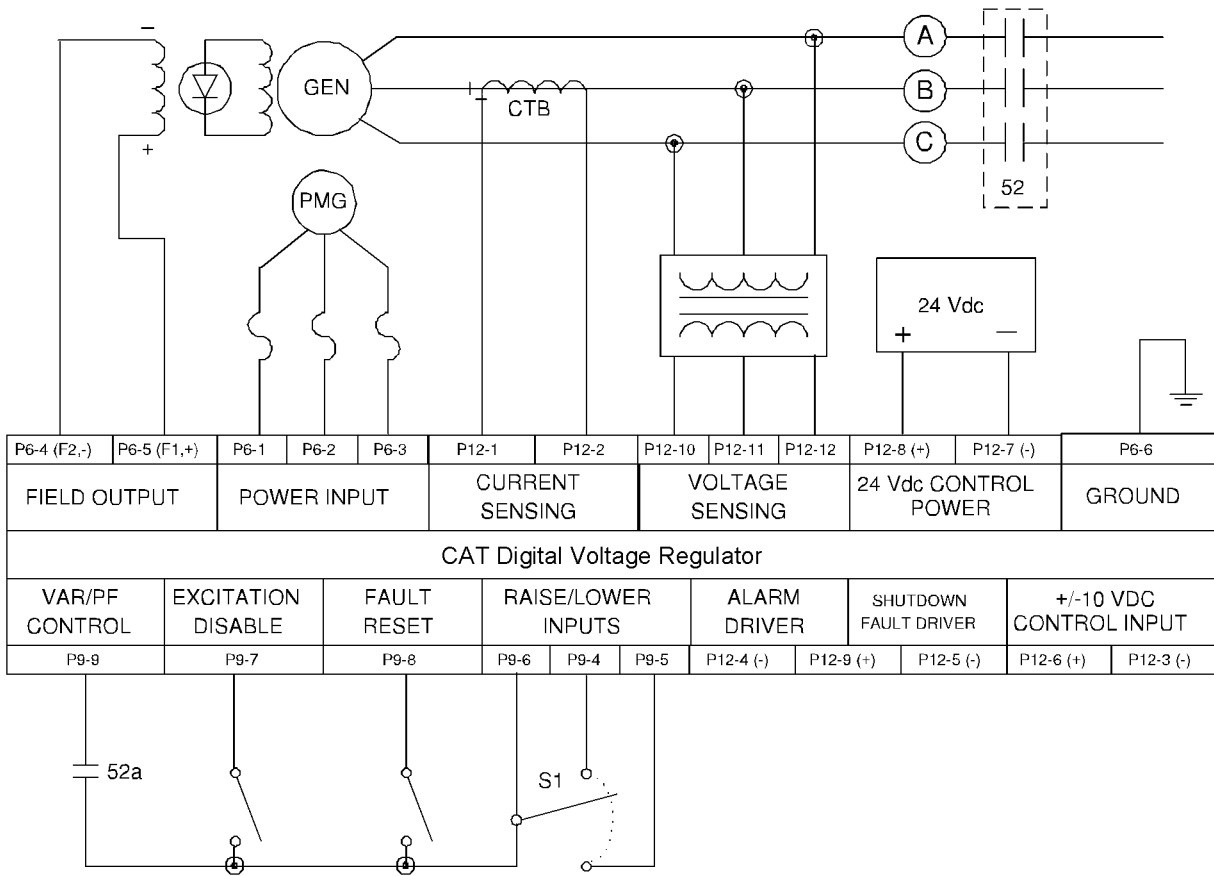

Illustration 63

g01015474

Typical Connections for PMG Power Input, ABC Rotation, and Three Phase Voltage Sensing

Notes:

- (A) 52a contact required only for Var/PF control. Var/PF enabled only when 52a is closed, inactive when open.
- (B) When excitation disable switch is open, excitation is enabled.
- (C) When fault reset switch is momentarily closed, any shutdown fault is reset.
- (D) S1 (SPST, spring return to center-off position) adjusts CAT Digital Voltage Regulator setpoint.
- (E) Alarm Driver and Shutdown Fault Driver are normally off.
- (F) The ± 10 VDC input provides adjustment of output.
- (G) Three-phase PMG is shown. For single-phase, remove P6-3 connection. For HV machines using 2 single phase PMGs in series, connect PMG leads 2 and 3 together, and connect leads 1 and 4 to CDVR pins P6-1 and P6-2, respectively.
- (H) Sensing potential transformer is required if line voltage exceeds 600 VAC.
- (I) When generator rotation is ACB, the connections for the CTB should be reversed.

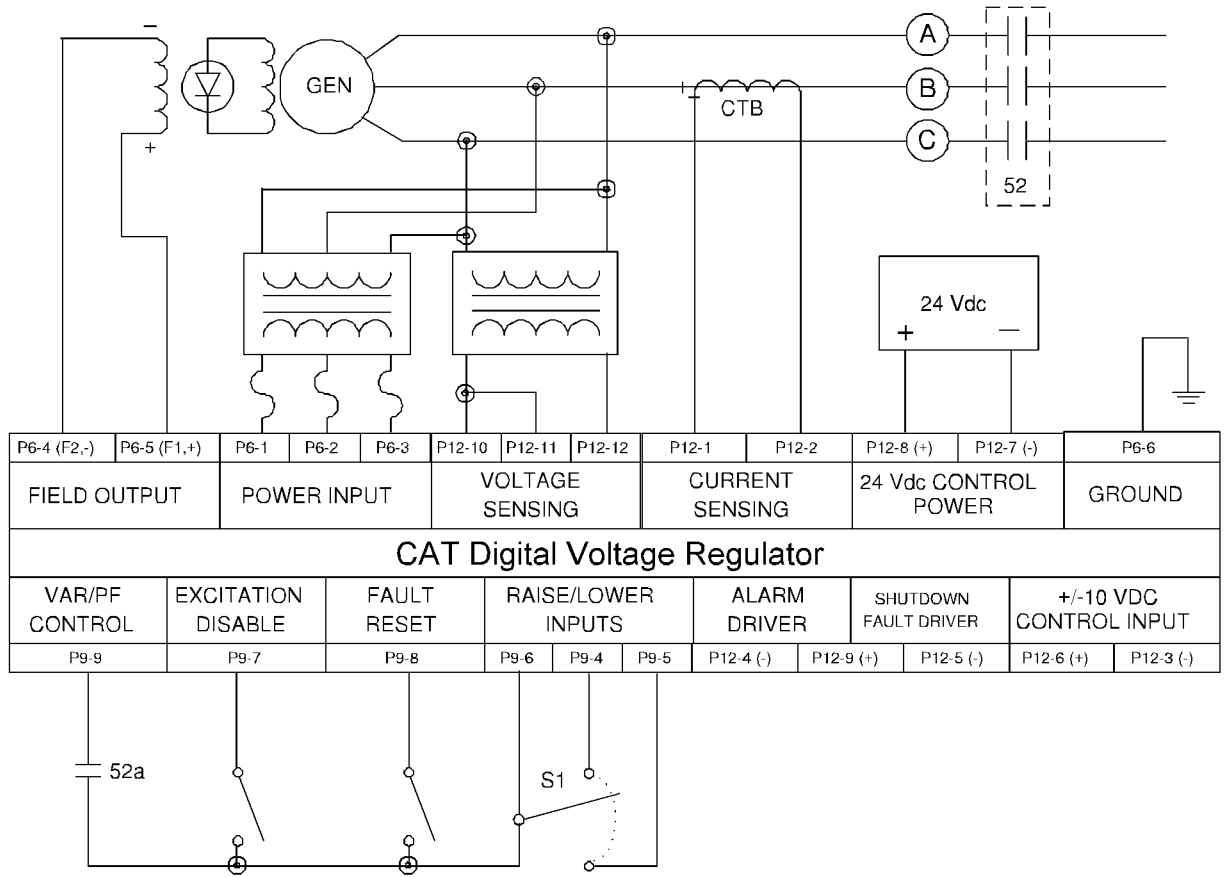

Illustration 64

g01015488

Typical Connections for Shunt Power Input, ABC Rotation, and Single Phase Voltage Sensing

Notes:

- (A) 52a contact required only for Var/PF control. Var/PF enabled only when 52a is closed, inactive when open.
- (B) When excitation disable switch is open, excitation is enabled.
- (C) When fault reset switch is momentarily closed, any shutdown fault is reset.
- (D) S1 (SPST, spring return to center-off position) adjusts CAT Digital Voltage Regulator setpoint.
- (E) Alarm Driver and Shutdown Fault Driver are normally off.
- (F) The ± 10 VDC input provides adjustment of output.
- (G) Sensing potential transformer is required if line voltage exceeds 600 VAC.
- (H) When generator rotation is ACB, the connections for the CTB should be reversed.

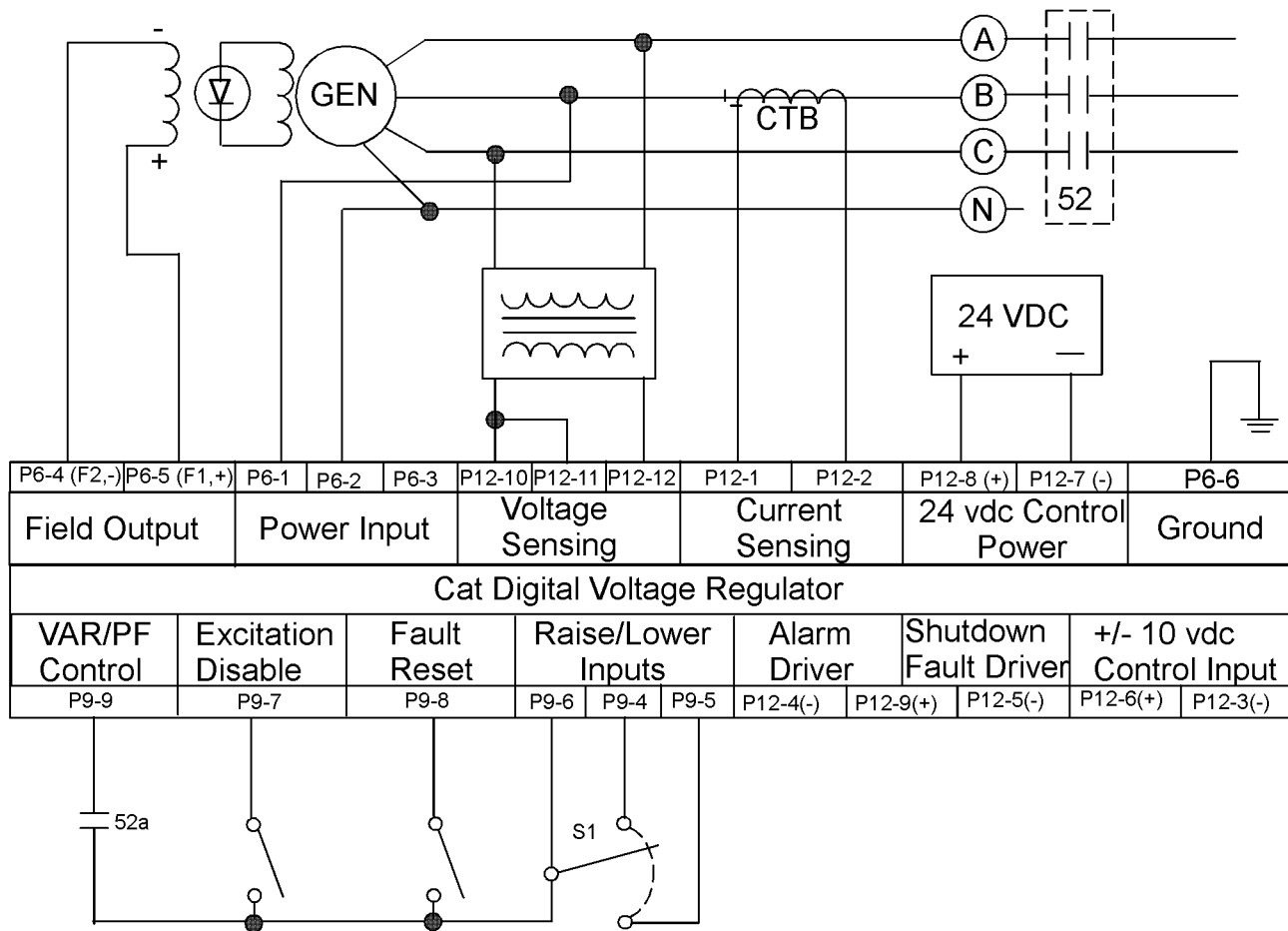

Illustration 65

g01408526

Typical Connections for a SE, L-N Directly Connected Power Input, ABC Rotation, and Single Phase Voltage Sensing (Generator less than 480V)

Notes:

- (A) 52a contact required only for Var/PF control. Var/PF enabled only when 52a is closed, inactive when open.
- (B) When excitation disable switch is open, excitation is enabled.
- (C) When fault reset switch is momentarily closed, any shutdown fault is reset.
- (D) S1 (SPST, spring return to center-off position) adjusts CAT Digital Voltage Regulator setpoint.
- (E) Alarm Driver and Shutdown Fault Driver are normally off.
- (F) The ± 10 VDC input provides adjustment of output.
- (G) Sensing potential transformer is required if line voltage exceeds 600 VAC.
- (H) When generator rotation is ACB, the connections for the CTB should be reversed.

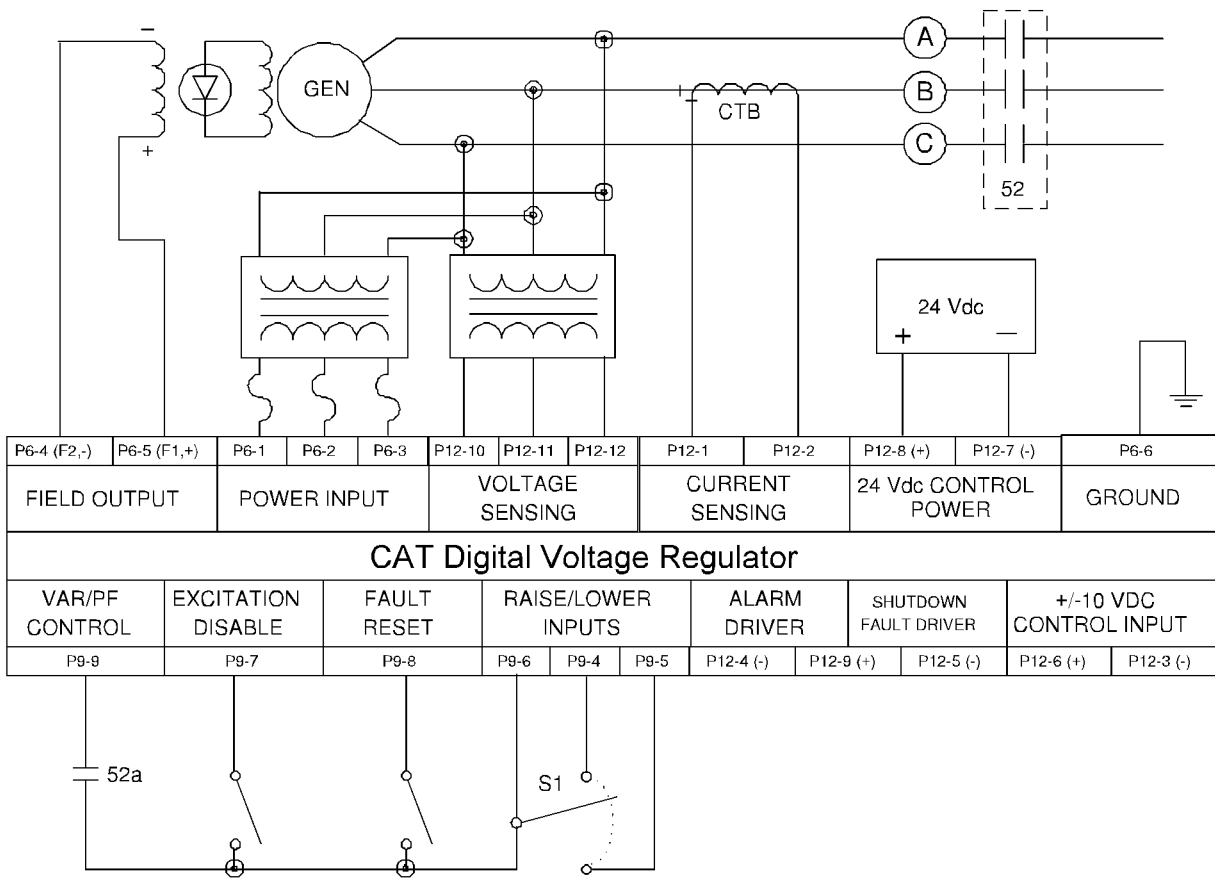

Illustration 66

g01015546

Typical Connections for Shunt Power Input, ABC Rotation, and Three Phase voltage Sensing

Notes:

- (A) 52a contact required only for Var/PF control. Var/PF enabled only when 52a is closed, inactive when open.
- (B) When excitation disable switch is open, excitation is enabled.
- (C) When fault reset switch is momentarily closed, any shutdown fault is reset.
- (D) S1 (SPST, spring return to center-off position) adjusts CAT Digital Voltage Regulator setpoint.
- (E) Alarm Driver and Shutdown Fault Driver are normally off.
- (F) The ± 10 VDC input provides adjustment of output.
- (G) Sensing potential transformer is required if line voltage exceeds 600 VAC.
- (H) When generator rotation is ACB, the connections for the CTB should be reversed.

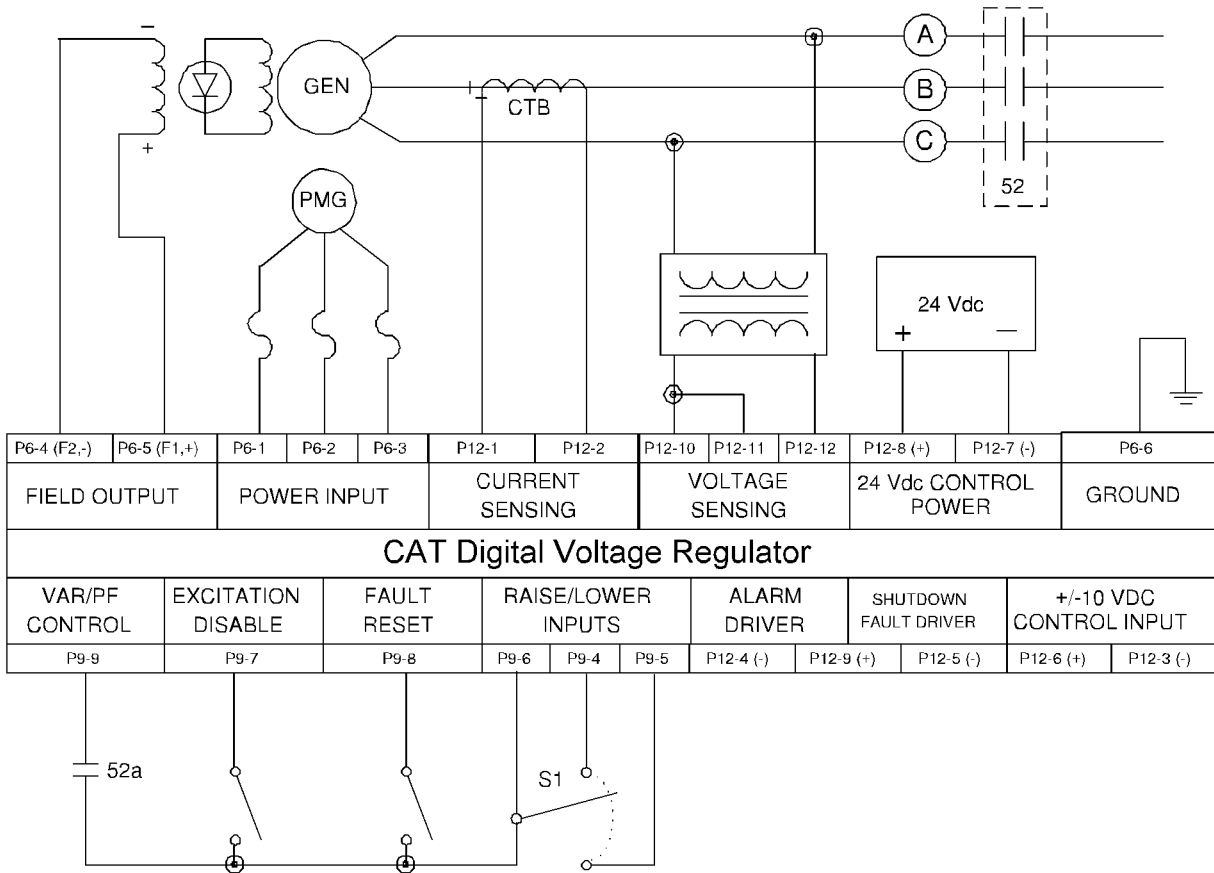

Illustration 67

g01015576

Typical Connections for PMG Power Input, ABC Rotation, and Single Phase Voltage Sensing

Notes:

- (A) 52a contact required only for Var/PF control. Var/PF enabled only when 52a is closed, inactive when open.
- (B) When excitation disable switch is open, excitation is enabled.
- (C) When fault reset switch is momentarily closed, any shutdown fault is reset.
- (D) S1 (SPST, spring return to center-off position) adjusts CAT Digital Voltage Regulator setpoint.
- (E) Alarm Driver and Shutdown Fault Driver are normally off.
- (F) The ± 10 VDC input provides adjustment of output.
- (G) Three-phase PMG is shown. For single-phase, remove P6-3 connection. For HV machines using 2 single phase PMGs in series, connect PMG leads 2 and 3 together, and connect leads 1 and 4 to CDVR pins P6-1 and P6-2, respectively.
- (H) Sensing potential transformer is required if line voltage exceeds 600 VAC.
- (I) When generator rotation is ACB, the connections for the CTB should be reversed.

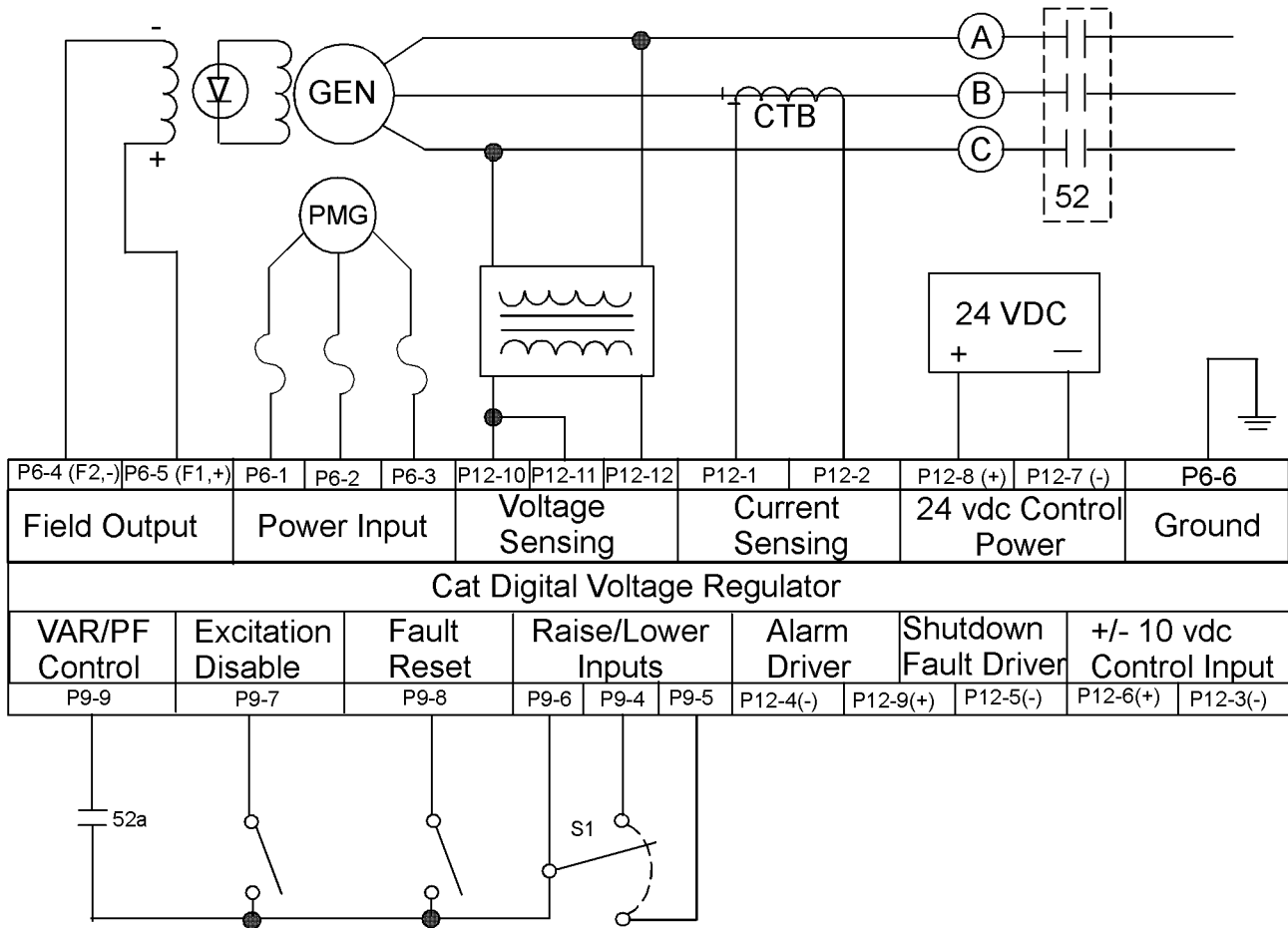

Illustration 68

g01425819

Typical Connections for PMG Power Input, ABC Rotation, and Single Phase Voltage Sensing

Notes:

- (A) 52a contact required only for Var/PF control. Var/PF enabled only when 52a is closed, inactive when open.
- (B) When excitation disable switch is open, excitation is enabled.
- (C) When fault reset switch is momentarily closed, any shutdown fault is reset.
- (D) S1 (SPST, spring return to center-off position) adjusts CAT Digital Voltage Regulator setpoint.
- (E) Alarm Driver and Shutdown Fault Driver are normally off.
- (F) The ±10 VDC input provides adjustment of output.
- (G) Three-phase PMG is shown. For single-phase, remove P6-3 connection. For HV machines using 2 single phase PMGs in series, connect PMG leads 2 and 3 together, and connect leads 1 and 4 to CDVR pins P6-1 and P6-2, respectively.
- (H) Sensing potential transformer is required if line voltage exceeds 600 VAC.
- (I) When generator rotation is ACB, the connections for the CTB should be reversed.

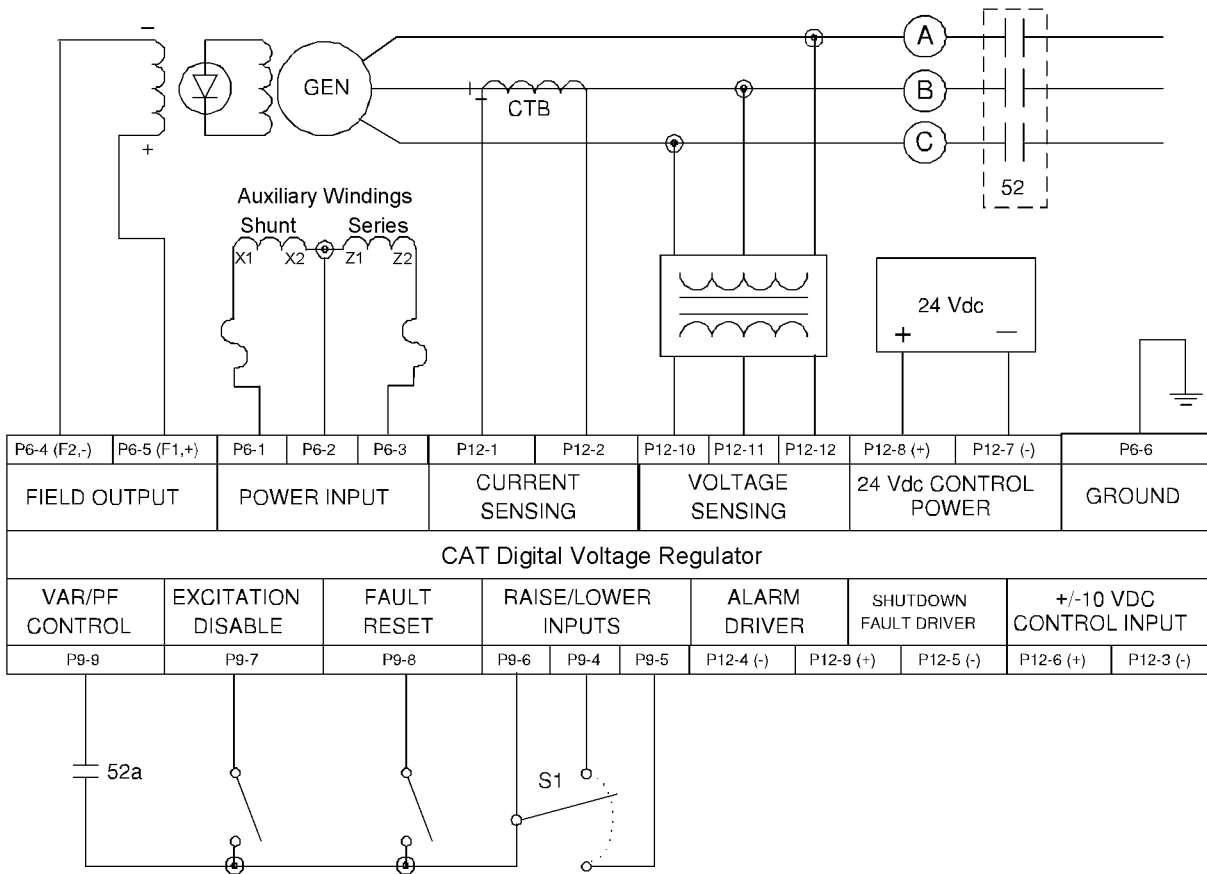

Illustration 69

g01112935

Typical Connections for Auxiliary Winding Regulation Excitation Principle (AREP) Power Input, ABC Rotation, and Three Phase Voltage Sensing

Notes:

- (A) 52a contact required only for Var/PF control. Var/PF enabled only when 52a is closed, inactive when open.
- (B) When excitation disable switch is open, excitation is enabled.
- (C) When fault reset switch is momentarily closed, any shutdown fault is reset.
- (D) S1 (SPST, spring return to center-off position) adjusts CAT Digital Voltage Regulator setpoint.
- (E) Alarm Driver and Shutdown Fault Driver are normally off.
- (F) The ± 10 VDC input provides adjustment of output.
- (G) Sensing potential transformer is required if line voltage exceeds 600 VAC.
- (H) When generator rotation is ACB, the connections for the CTB should be reversed.

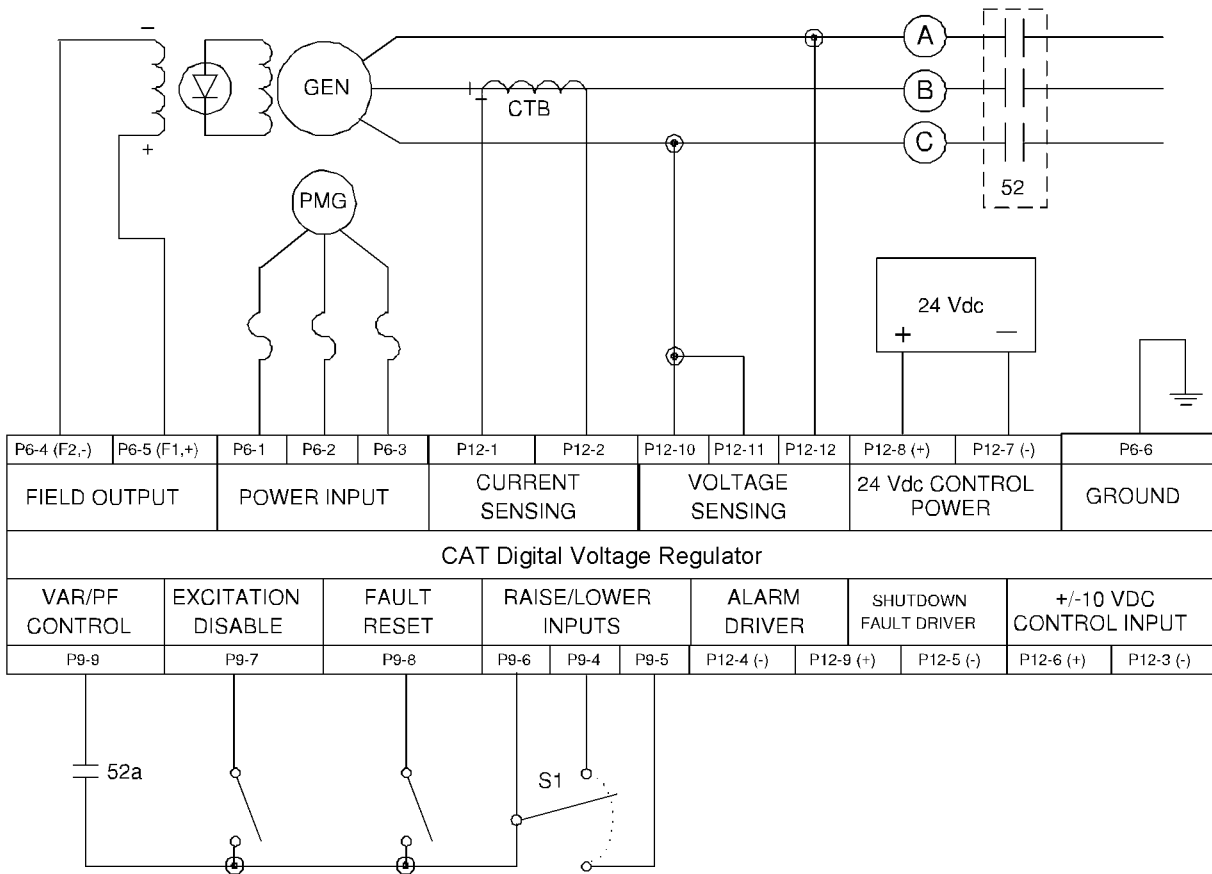

Illustration 70

g01112701

Typical Connections for PMG Power Input, ABC Rotation, and Single Phase Voltage Sensing (Generator Less Than 600 Volts)

Notes:

- (A) 52a contact required only for Var/PF control. Var/PF enabled only when 52a is closed, inactive when open.
- (B) When excitation disable switch is open, excitation is enabled.
- (C) When fault reset switch is momentarily closed, any shutdown fault is reset.
- (D) S1 (SPST, spring return to center-off position) adjusts CAT Digital Voltage Regulator setpoint.
- (E) Alarm Driver and Shutdown Fault Driver are normally off.
- (F) The ± 10 VDC input provides adjustment of output.
- (G) Three-phase PMG is shown. For single-phase, remove P6-3 connection. For HV machines using 2 single phase PMGs in series, connect PMG leads 2 and 3 together, and connect leads 1 and 4 to CDVR pins P6-1 and P6-2, respectively.
- (H) Sensing potential transformer is required if line voltage exceeds 600 VAC.
- (I) When generator rotation is ACB, the connections for the CTB should be reversed.

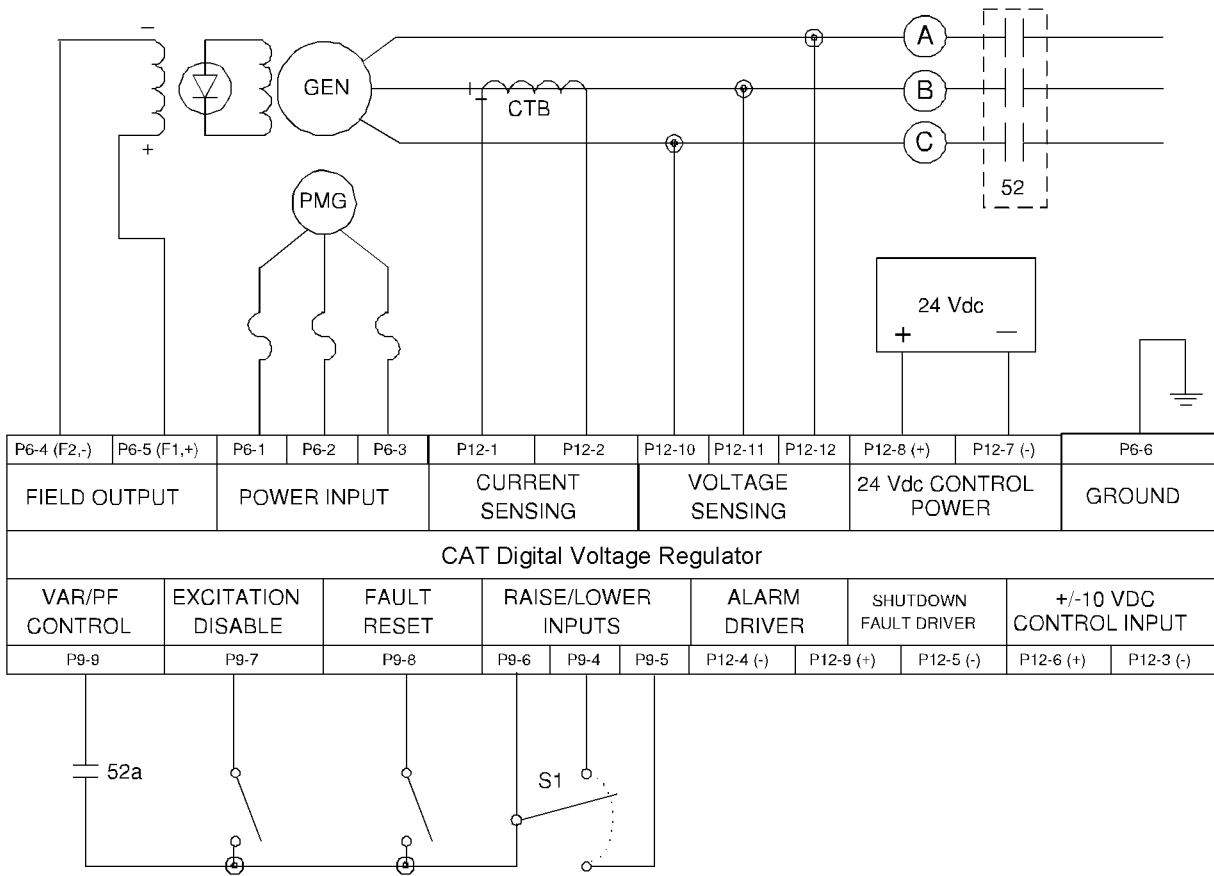

Illustration 71

g01112717

Typical connections for PMG power input and three phase direct voltage sensing (generator less than 600 volts)

Notes:

- (A) 52a contact required only for Var/PF control. Var/PF enabled only when 52a is closed, inactive when open.
- (B) When excitation disable switch is open, excitation is enabled.
- (C) When fault reset switch is momentarily closed, any shutdown fault is reset.
- (D) S1 (SPST, spring return to center-off position) adjusts CAT Digital Voltage Regulator setpoint.
- (E) Alarm Driver and Shutdown Fault Driver are normally off.
- (F) The ± 10 VDC input provides adjustment of output.
- (G) Three-phase PMG is shown. For single-phase, remove P6-3 connection.
- (H) Sensing potential transformer is required if line voltage exceeds 600 VAC. For HV machines using 2 single phase PMGs in series, connect PMG leads 2 and 3 together, and connect leads 1 and 4 to CDVR pins P6-1 and P6-2, respectively.
- (I) When generator rotation is ACB, the connections for the CTB should be reversed.

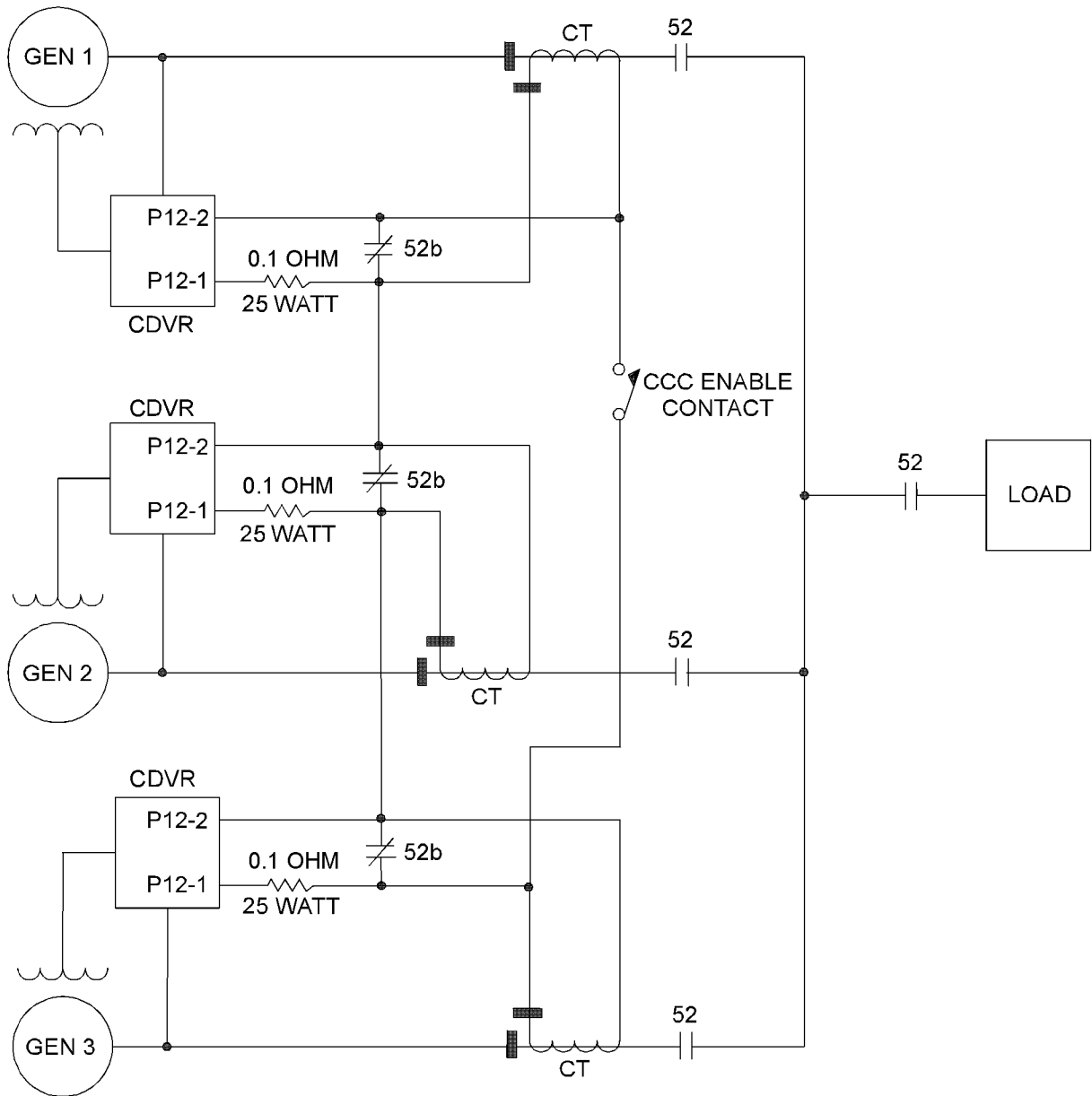

Illustration 72
Typical connections for cross current compensation

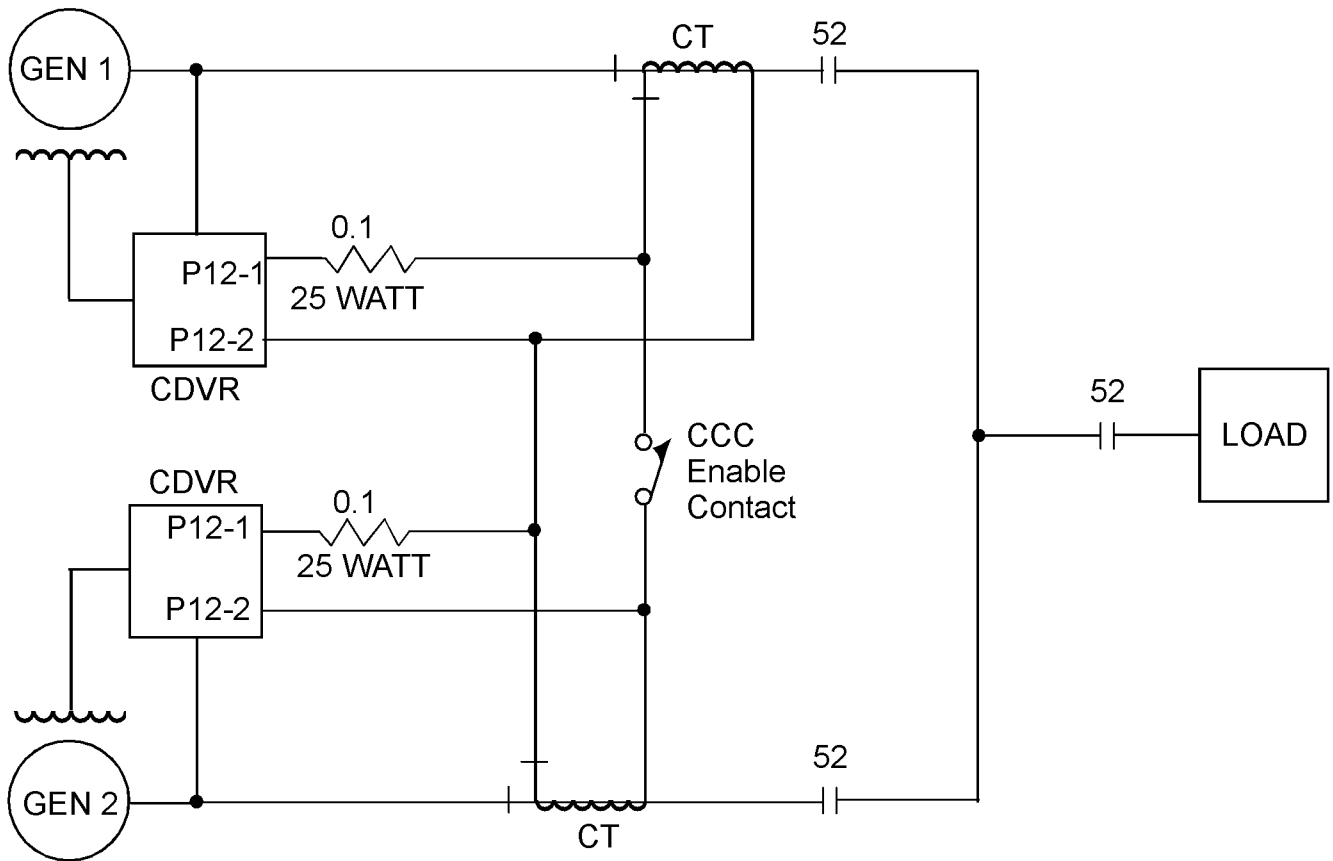

Illustration 73
Typical connections for cross current compensation (two CDVR's).

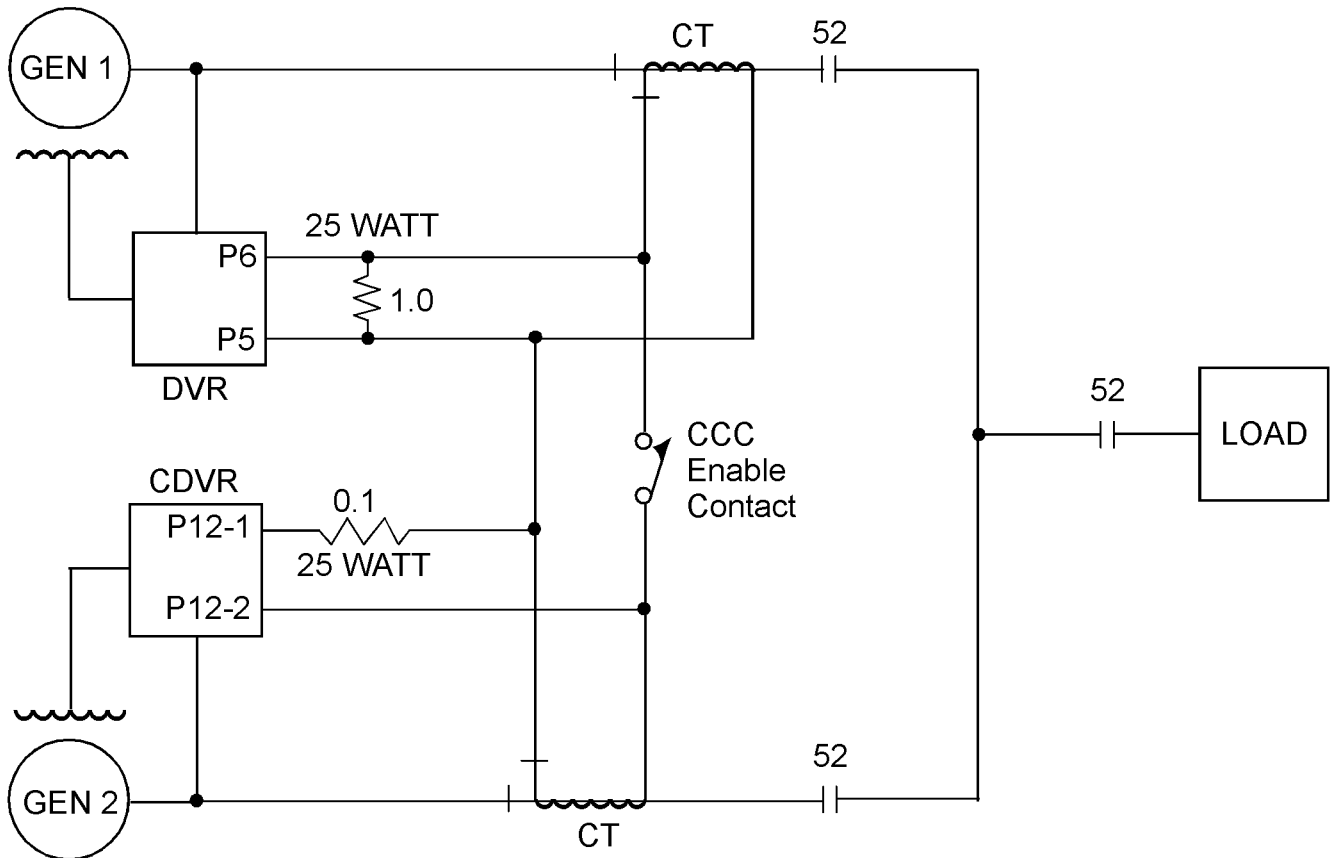

Illustration 74
Typical connections for cross current compensation (one CDVR and one DVR).

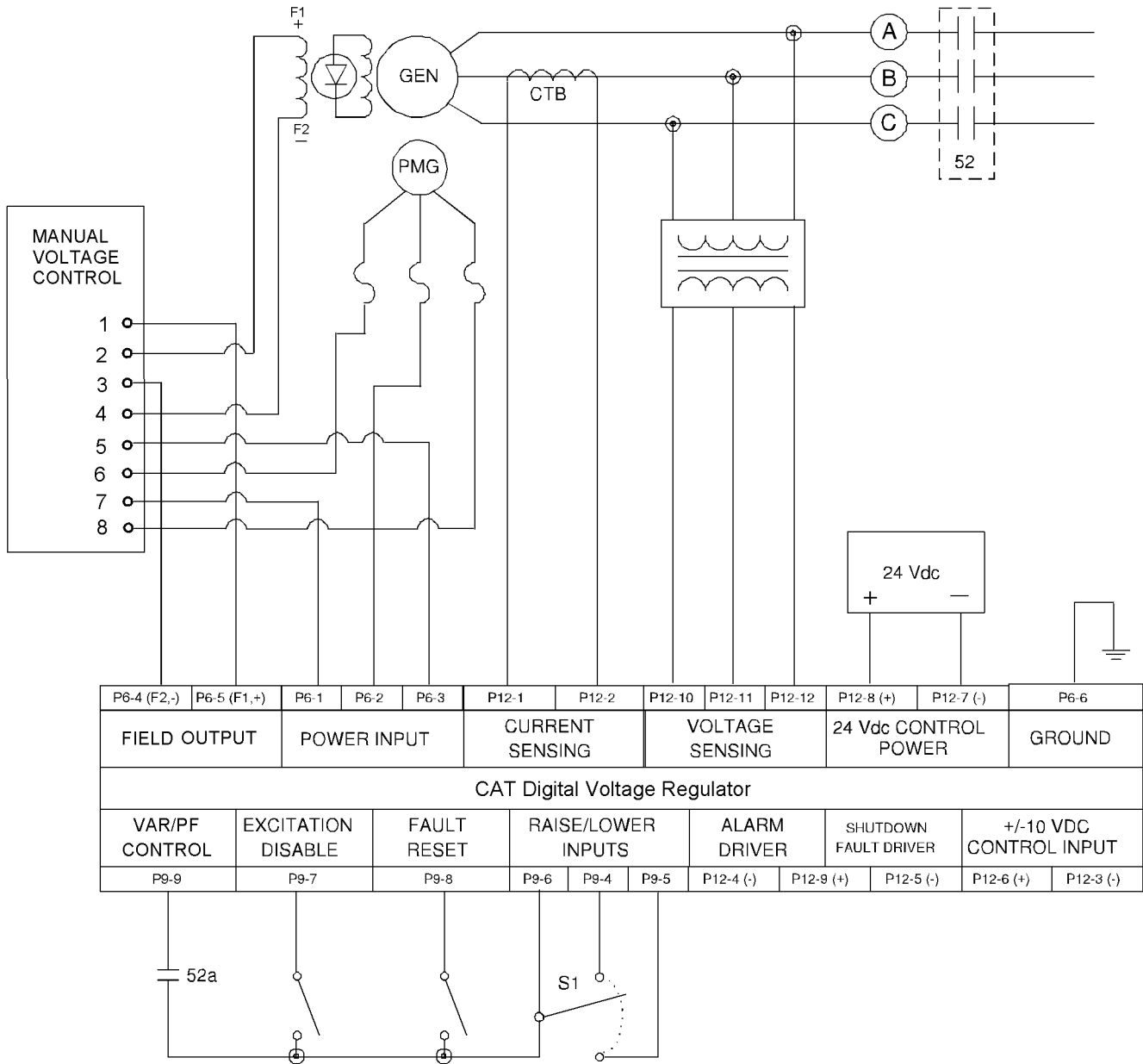

Illustration 75

Typical connections for a manual voltage control

Index

C

Cross Current Compensation 14

D

Dimensions 7

E

Electrical 4

G

Gain Setting - Adjust 61
 General Information 8, 20
 Connectors 9
 Preventive Maintenance 20
 Generator Overcurrent - Troubleshoot 67

H

High Voltage - Troubleshoot 66

I

Important Safety Information 2

K

KVAR Regulation 14

L

Line Loss Compensation 12
 Loading and Stopping Profile 11
 Low Voltage - Troubleshoot 65

N

No Line Loss Compensation - Troubleshoot 69
 No Voltage - Troubleshoot 62
 No Voltage Droop - Troubleshoot 70

P

Parameter Viewing and Configuration (Caterpillar
 Electronic Technician) 57
 Viewing Metering Parameters Using Cat ET
 Software 60

Parameter Viewing and Configuration (Caterpillar PC
 Software) 23
 Changing Settings 24
 Flash the CDVR Using Cat ET Software 55
 Installing the Caterpillar PC Software 23
 Sending and Receiving Settings 25
 Setting Definitions 26
 Settings Files 47
 Starting Caterpillar PC Software 24
 Uploading Embedded Firmware Using the CDVR
 PC Software 52
 Parameters 16
 General Information 16
 Poor Voltage Regulation - Troubleshoot 68
 Power Factor Regulation 15

R

Reactive Voltage Droop 13
 Remote Communication 17
 Establishing Communication 18
 Terminating Communication 19
 Reverse VAR Condition - Troubleshoot 68

S

Service Tools 20
 Specifications Section 4
 Startup Procedure 21
 Startup Profile Function 10
 Systems Operation Section 8

T

Table of Contents 3
 Testing and Adjusting 20
 Testing and Adjusting Section 20
 Troubleshooting 62
 Alarm or Shutdown Faults 62

U

Unstable Voltage - Troubleshoot 66

V

Voltage Regulation 12

W

Wiring Diagrams 71

