



FORM NO. SENR3473-01

FOR USE IN SERVICE MANUALS:  
ELECTRIC SET GENERATORS, SENR7958  
3114 & 3116 GENERATOR SET ENGINES,  
SENR3940

# Service Manual

---

## **VR3 Voltage Regulator 10/12 Lead, Self-Excited SR4 Generators**

---

## Important Safety Information

Most accidents involving product operation, maintenance and repair are caused by failure to observe basic safety rules or precautions. An accident can often be avoided by recognizing potentially hazardous situations before an accident occurs. A person must be alert to potential hazards. This person should also have the necessary training, skills and tools to perform these functions properly.

**Improper operation, lubrication, maintenance or repair of this product can be dangerous and could result in injury or death.**

**Do not operate or perform any lubrication, maintenance or repair on this product, until you have read and understood the operation, lubrication, maintenance and repair information.**

Safety precautions and warnings are provided in this manual and on the product. If these hazard warnings are not heeded, bodily injury or death could occur to you or other persons.

The hazards are identified by the "Safety Alert Symbol" and followed by a "Signal Word" such as "WARNING" as shown below.



The meaning of this safety alert symbol is as follows:

**Attention! Become Alert! Your Safety is Involved.**

The message that appears under the warning, explaining the hazard, can be either written or pictorially presented.

Operations that may cause product damage are identified by NOTICE labels on the product and in this publication.

Caterpillar cannot anticipate every possible circumstance that might involve a potential hazard. The warnings in this publication and on the product are therefore not all inclusive. If a tool, procedure, work method or operating technique not specifically recommended by Caterpillar is used, you must satisfy yourself that it is safe for you and others. You should also ensure that the product will not be damaged or made unsafe by the operation, lubrication, maintenance or repair procedures you choose.

The information, specifications, and illustrations in this publication are on the basis of information available at the time it was written. The specifications, torques, pressures, measurements, adjustments, illustrations, and other items can change at any time. These changes can affect the service given to the product. Obtain the complete and most current information before starting any job. Caterpillar dealers have the most current information available. For a list of the most current publication form numbers available, see the Service Manual Contents Microfiche, REG1139F.

# Index

## Systems Operation

C Introduction .....	4
Operation .....	4

## Testing And Adjusting

C Bench Test .....	11
C Schematics – 10/12 Pole Self-Excited Generators ....	7
Test Equipment .....	6
Troubleshooting .....	9
Introduction .....	9
Problem 1 - No AC Voltage .....	9
Problem 2 - Low AC Voltage .....	9
Problem 3 - High AC Voltage .....	10
Problem 4 - Unstable AC Voltage .....	11
Problem List .....	9

## Attachments

Manual Voltage Control .....	17
Remote Voltage Control .....	13
Series Boost .....	14
Single Phase Sensing .....	21
Voltage Droop Transformer And Adjustment Rheostat For Parallel Operation .....	20

A “C” in the left margin is an indication of a change from the former issue.

# Systems Operation

## c Introduction

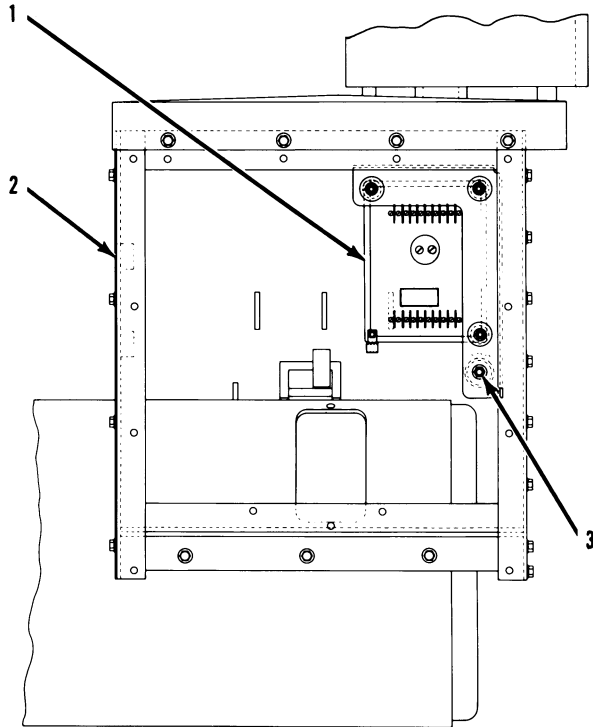

C37581P1

SR4 Generator (Partial View)  
(1) VR3 regulator. (2) Terminal box. (3) Droop rheostat location.

This manual covers the VR3 voltage regulator as it is used on 10/12 lead, self-excited SR4 generators. This manual must be used in conjunction with service manual Electric Set Generators SENR7958 and Operation and Maintenance Manual SEBU6150.

**Follow all safety procedures and warnings in the above generator manuals.**

VR3 regulator (1) is located in generator terminal box (2).

**C NOTE:** There are two VR3 regulators; an earlier one fuse version, and the current two fuse version. The additional fuse of current VR3's, is located next to the single fuse of the earlier version. The additional fuse on current VR3's offers more protection to the internal parts of the VR3.

## Operation

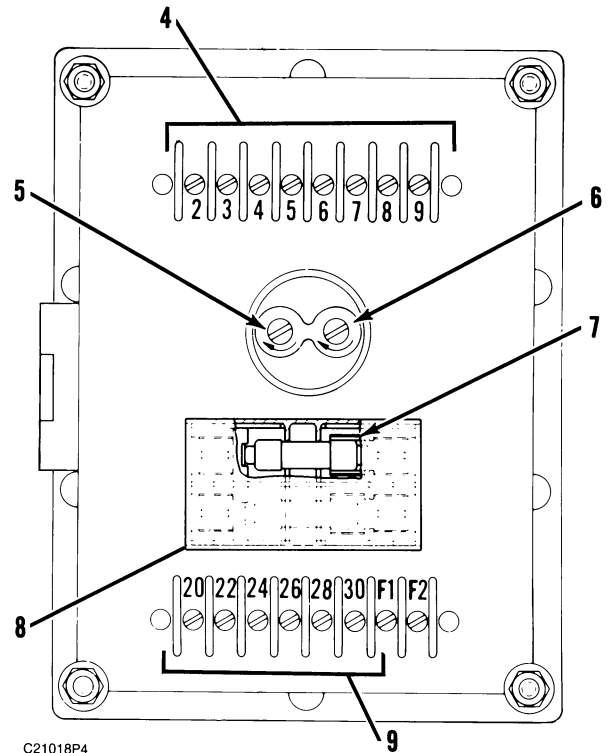

C21018P4

VR3 Regulator - Current Two Fuse Version Shown  
(4) Terminal strip (for attachments). (5) Rheostat (voltage level). (6) Rheostat (voltage gain). (7) Fuses. (8) Fuse cover. (9) Terminal strip (for sensing and power).

The purpose of the VR3 regulator is to keep generator output voltage at a rated value. There are two controls on the VR3 that are standard.

- Voltage level rheostat (5) provides a no load voltage adjustment of approximately +10 to -20%.
- Voltage gain rheostat (6) provides an adjustment to compensate for engine RPM droop with load. Rheostat (6) can be adjusted to keep the same voltage at no load and full load, even when there is a small change in frequency (rpm).

Rheostats (5) and (6) are multiple turn. They do not have a fixed stop at the end of travel, but have an override ratchet.

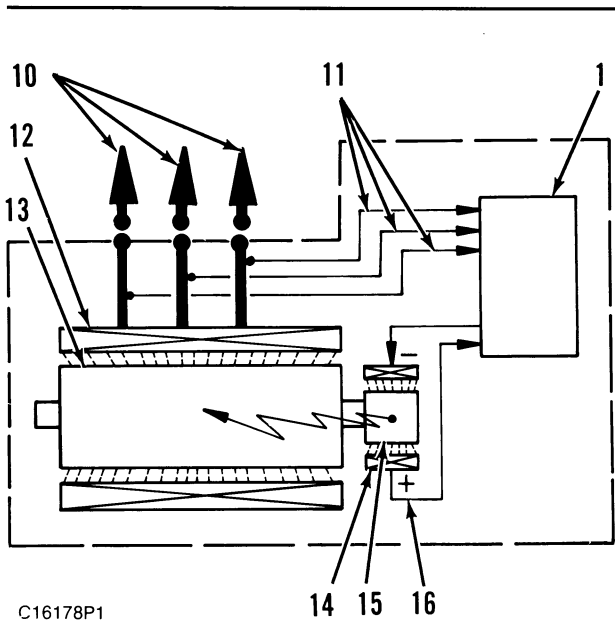

C16178P1

#### SR4 Generator Schematic

(Self-excited 10/12 lead)

(1) VR3 regulator. (10) Lines (3-phase output voltage). (11) Lines (sensing voltage and AC power). (12) Main stator. (13) Main rotor. (14) Exciter stator. (15) Exciter rotor. (16) Lines (VDC excitation voltage).

VR3 regulator (1) uses all three phases to sense generator output voltage. Lines (11) function as sensing lines by tapping into generator output and connecting to terminals 20, 22 and 24 (AC input) on fuses (7) and terminal strip (9). [Regulator (1) can be reconnected for single phase sensing]. Like other SR4 generator regulators, the VR3 regulates voltage based on volts per hertz. The VR3 offers an approximate 8 volts per hertz characteristic.

Lines (11) also function to provide AC power for excitation to the VR3 regulator. The regulator rectifies the AC voltage and controls the excitation current to exciter stator (14).

**C NOTE:** There are two VR3 regulators; an earlier one fuse version, and the current two fuse version. The additional fuse on, current VR3's, is located next to the single fuse of the earlier version. The additional fuse on current VR3's offers more protection to the internal parts of the VR3.

Fuses (7) limit the field current in the case of an internal short circuit or loss of sensing signal.

**NOTE:** VR3 regulators include an overcurrent shutoff to protect generator components. If the unit operates for an extended period of time at low rpm, the overcurrent shutoff may trip. It will reset automatically when the generator is completely shutoff. For 60 Hz generator operation, the recommended minimum operating speed is:

Four pole .....	1200 rpm
Six pole .....	800 rpm

**NOTE:** VR3 regulators are sensitive to A-B-C phase rotation. Connections must be as shown in this manual; T7 to 22, T8 to 24, and T9 to 20.

**C NOTE:** If it is required to provide a shutoff for the VR3 regulator, connect a SPDT switch (rated 20 amp, 240 volt) in line 24.

# Testing And Adjusting

## WARNING

When servicing or repairing electric power generation equipment, do the following:

- a. Make sure the unit is off-line (disconnected from utility and/or other generators power service), and either locked out or tagged "DO NOT OPERATE".
- b. Make sure the generator engine is stopped.
- c. Make sure all batteries are disconnected.
- d. Make sure all capacitors are discharged.

When power generation equipment must be in operation to make tests and/or adjustments, high voltage and current are present. Make sure the testing equipment is designed for and correctly operated for the high voltage and current tests being made. Improper test equipment may fail and present a high voltage shock hazard to its user.

## WARNING

Do not connect the generator to a utility electrical distribution system, unless it is isolated from the system. Electrical feedback into the distribution system can occur and could cause personal injury or death.

Open and secure the main distribution system switch or, if the connection is permanent, install a double throw transfer switch to prevent electrical feedback. Some generators are specifically approved by a utility to run in parallel with the distribution system and isolation may not be required. Always check with your utility as to the applicable circumstances.

# Test Equipment

C37282P1

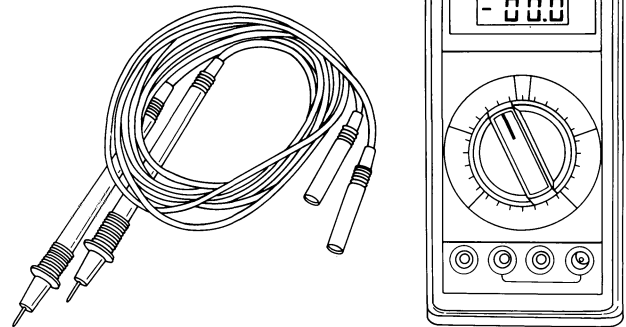

6V7070 Heavy Duty Digital Multimeter

Caterpillar Digital Multimeters measure voltage, resistance, or current up to 10 amps. The diode function checks rectifiers. See Special Instruction SEHS7734 for the operation of 6V7070.



4C4693 Regulator Tester

The 4C4693 Regulator Tester is a bench top instrument used to test VR3 regulators. This provides a way to check a regulator without using a generator set.

# c Schematics – 10/12 Pole Self-Excited Generators

## VR3 - Current Two Fuse Version

C37582P1

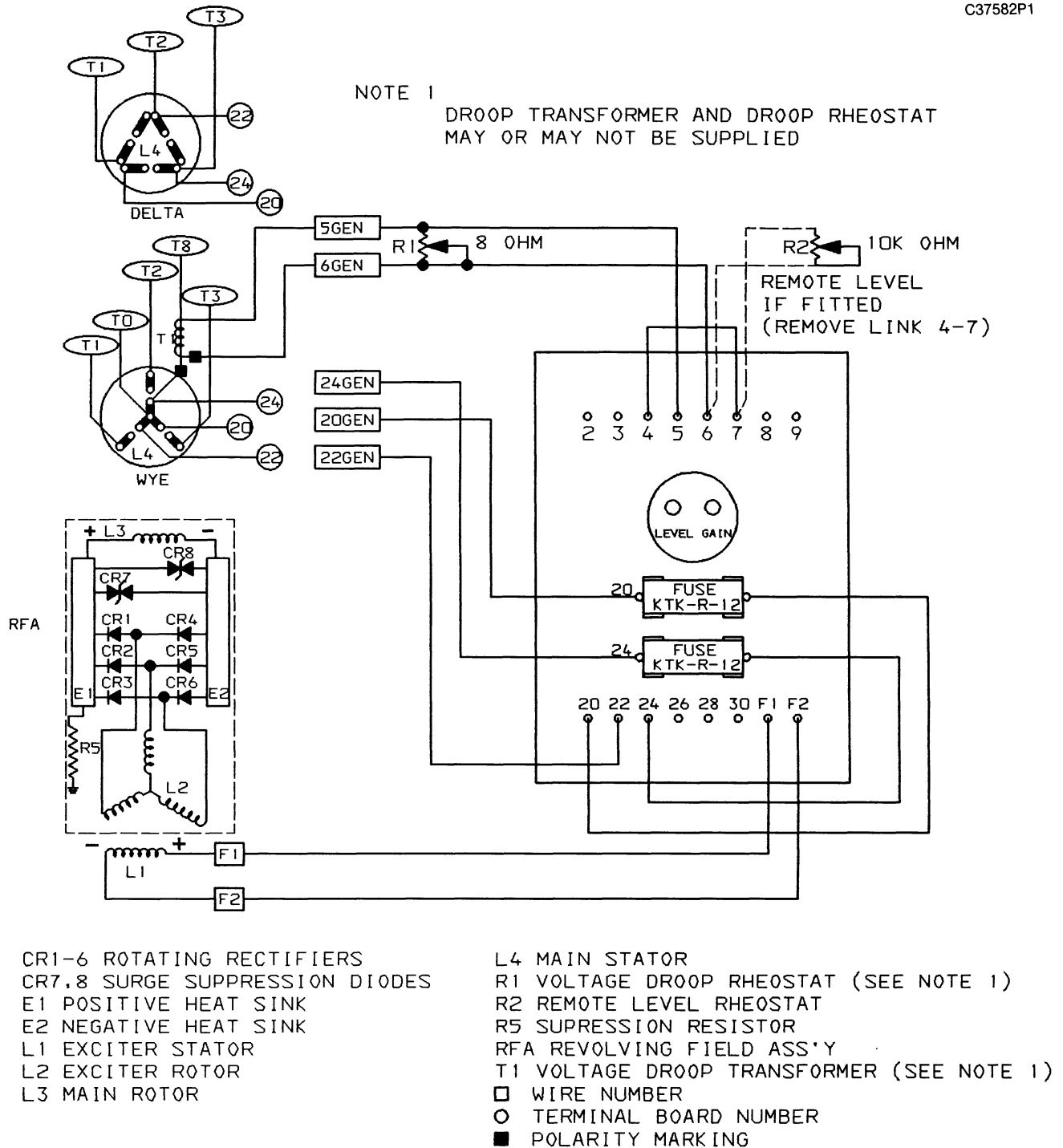

SR-4 GENERATOR SCHEMATIC (10/12 LEAD, SELF-EXCITED & 2 FUSE TYPE)

NOTE : GENERATOR STATOR LEADS TERMINALS T10, T11 AND T12 TO BE CONNECTED TO FORM THE NEUTRAL LEAD (TO) ON 12 LEAD WYE CONNECTED GENERATORS. DELTA CONNECTIONS ONLY AVAILABLE WITH 12 LEAD GENERATORS.

**VR3 - Earlier One Fuse Version**

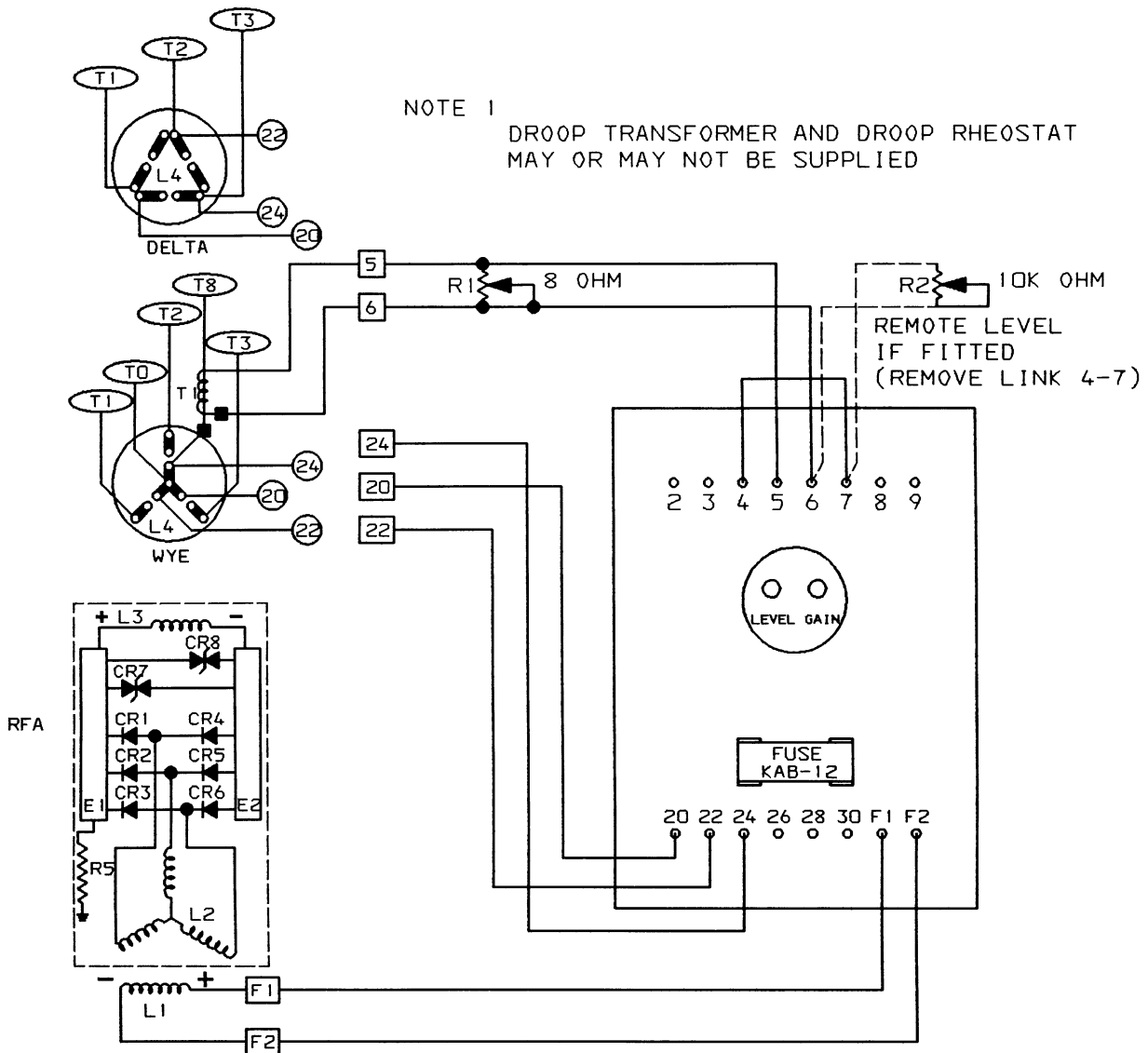

NOTE 1  
DROOP TRANSFORMER AND DROOP RHEOSTAT  
MAY OR MAY NOT BE SUPPLIED

CR1-6 ROTATING RECTIFIERS  
CR7,8 SURGE SUPPRESSION DIODES  
E1 POSITIVE HEAT SINK  
E2 NEGATIVE HEAT SINK  
L1 EXCITER STATOR  
L2 EXCITER ROTOR  
L3 MAIN ROTOR

L4 MAIN STATOR  
R1 VOLTAGE DROOP RHEOSTAT (SEE NOTE 1)  
R2 REMOTE LEVEL RHEOSTAT  
R5 SUPPRESSION RESISTOR  
RFA REVOLVING FIELD ASS'Y  
T1 VOLTAGE DROOP TRANSFORMER (SEE NOTE 1)  
□ WIRE NUMBER  
○ TERMINAL BOARD NUMBER  
■ POLARITY MARKING

**SR-4 GENERATOR SCHEMATIC (10/12 LEAD, SELF-EXCITED & 1 FUSE TYPE)**

NOTE : GENERATOR STATOR LEADS TERMINALS T10, T11 AND T12 TO BE CONNECTED TO FORM THE NEUTRAL LEAD (T0) ON 12 LEAD WYE CONNECTED GENERATORS. DELTA CONNECTIONS ONLY AVAILABLE WITH 12 LEAD GENERATORS.

C37583P1

# Troubleshooting

## Introduction

Check for loose or corroded terminals. Make sure wire connections are correct. Check accuracy of voltmeter and frequency meter/tachometer.

To reduce troubleshooting time, simplify the system or circuit by eliminating non-essential components such as remote voltage control, manual control, etc. If, at this point, it is determined that the basic system is functioning, the circuits or components can be added back in, one at a time until the problem is located.

If elimination of non-essential components does not correct the problem, the troubleshooting procedure will check components in the basic system. If all other basic components (i.e. rotating field assembly, exciter stator, etc.) are operating correctly, then replace the VR3 regulator. As a last step after confirming correct operation under no load conditions, operate the generator under a load.

The VR3 regulator is serviced as a complete unit. Its fuses are the only replaceable part. **VR3 regulators must be checked through the bench test before making a claim on warranty (see Bench Test).**

## Problem List

Problem 1 - No AC Voltage.

Problem 2 - Low AC Voltage.

Problem 3 - High AC Voltage.

Problem 4 - Unstable AC Voltage.

## Problem 1 - No AC Voltage

### Procedure A - Check AC Voltage Between Regulator Terminals 20 And 22

- If above 200 volts:  
Check meters.
- If 0 volts:  
Flash the field; see SR4 Generator Service Manual, Form No. SENR3985.
- If 0 to 15 volts:  
Go to Procedure B.

## Procedure B - Isolate Regulator

Disconnect leads from regulator terminals F1 and F2. Connect a 12 volt automotive type battery across exciter leads F1 (+) and F2 (-). Operate generator at half of the rated speed. Then slowly increase rpm.

- If voltage at regulator terminals 20 and 22 is 0 to 15 volts (AC), shutdown the generator and:
  - a. Check exciter stator L1 continuity.
  - b. Check rotating rectifiers CR1-6 (rotating rectifier block).
  - c. Check surge suppression diodes CR7-8 (varistors).
  - d. Check main rotor L3 continuity.
  - e. Check exciter rotor L2 continuity.

**NOTE:** For more information, see SR4 Generator Service Manual, Form No. SENR3985.

- If balanced AC voltage between regulator terminals 20-22-24 that increases with rpm:  
Go to Procedure C.

## Procedure C - Isolate Attachments

Reconnect leads to regulator terminals F1 and F2. Disconnect all attachments such as series boost, manual voltage control, remote voltage control, droop transformer, etc.

**NOTE:** If remote mounted voltage adjustment is disconnected, connect jumper across terminals 4 and 7.

Check all connections to regulator and the regulator fuses.

- If generator output voltage is normal:  
Check attachments.
- If voltage at regulator terminals 20 and 22 is 0 to 15 volts:
  - a. Replace regulator.
  - b. Go to Bench Test for bench check of regulator.

## Problem 2 - Low AC Voltage

### C Procedure A - Check Engine RPM (Frequency)

Gen. Poles	Frequency	RPM
6	50 Hz.	1000
6	60 Hz.	1200
4	50 Hz.	1500
4	60 Hz.	1800

### Procedure B - Adjust Voltage Level With Gain Adjustment Full Counter-Clockwise

- Voltage level adjustment range should be within +10% to -20% of rated voltage:
  - a. Check meters.
  - b. Go to Procedure C.

### Procedure C - Check AC Voltage Between Regulator Terminals 20 And 22

- If greater than approximately 200 volts:  
Check meters.
- If lower than 200 volts:  
Go to Procedure D.

### Procedure D - Isolate Regulator

Disconnect leads from regulator terminals F1 And F2. Connect a 12 volt automotive type battery across exciter leads F1 (+) and F2 (-). Operate generator at half of the rated speed. Then slowly increase RPM.

- If voltage at regulator terminals 20 and 22 is less than 100 volts, shutdown the generator and:
  - a. Check rotating rectifiers CR1-6 (rotating rectifier block).
  - b. Check surge suppression diodes CR7-8 (varistors).
  - c. Check exciter stator L1 resistance between F1 and F2 leads. Exciter stator resistance should be approximately 3 to 5 ohms.

**NOTE:** For more information, see SR4 Generator Service Manual, Form No. SENR3985.

- If balanced AC voltage between regulator terminals 20-22-24 that increases with RPM:  
Go to Procedure E.

### Procedure E - Isolate Attachments

Connect exciter stator L1 leads to regulator terminals F1 and F2. Disconnect all attachments such as series boost, manual voltage control, remote voltage control, droop transformer, etc.

**NOTE:** If remote mounted voltage adjustment is disconnected, connect jumper across terminals 4 and 7.

Check all connections to the regulator and the regulator fuses.

- If generator output voltage is normal:  
Check attachments.
- If voltage at regulator terminals 20 and 22 cannot be adjusted to rated voltage and rated frequency at no load:
  - a. Replace regulator.
  - b. Bench test the regulator; see Bench Test.

## Problem 3 - High AC Voltage

### C Procedure A - Check Engine RPM (Frequency)

Gen. Poles	Frequency	RPM
6	50 Hz.	1000
6	60 Hz.	1200
4	50 Hz.	1500
4	60 Hz.	1800

### Procedure B - Adjust Voltage Level With Gain Adjustment Full Counterclockwise

- Voltage level adjustment range should be within +10 to -20% of rated voltage:
  - a. Check meter.
  - b. Go to Procedure C.
- Check accuracy of voltmeter.

### Procedure C - Check Connections To Regulator

- If connections are correct:  
Go to Procedure D.

### Procedure D - Isolate Attachments

Disconnect attachments such as series boost, manual voltage control, etc. Operate at rated rpm.

**NOTE:** If remote mounted voltage adjustment is disconnected, connect jumper across terminals 4 and 7.

- If generator output voltage is normal:  
Check attachments.
- If voltage cannot be adjusted to rated voltage at rated frequency:
  - a. Replace regulator.
  - b. Bench test the regulator; see Bench Test.

## Problem 4 - Unstable AC Voltage

### Procedure A - Check Engine RPM

- Governor operation is unstable:
  - a. Correct engine problem. Reference engine service manual.
  - b. Go to Procedure B.

### Procedure B - Check For Loose Connections

- If connections are okay:  
Go to Procedure C.

### Procedure C - Isolate Regulator

Disconnect leads F1 and F2 from their respective terminals on the regulator. Connect a 12 volt automotive type battery across exciter leads F1 and F2. Operate at half of rated speed and then slowly increase rpm.

- Voltage at regulator terminals 20-22 is unstable, shutdown the generator and:
  - a. Check connections to rotating rectifiers CR1-6 (rotating rectifier block), main field poles and other connections on the rotating (revolving) field.
  - b. Check connections to excitor stator L1.
- If stable balanced AC voltage between regulator terminals 20-22-24 that increases with rpm:  
Go to Procedure D.

### Procedure D - Isolate Attachments

Reconnect leads to regulator terminals F1 and F2. Disconnect all attachments such as series boost, manual voltage control, remote voltage control, droop transformer, etc.

**NOTE:** If remote mounted voltage adjustment is disconnected, connect jumper across terminals 4 and 7.

Check all connections to the regulator and regulator fuses.

- If generator output voltage is normal:  
Check attachments.
- Voltage at regulator terminals 20-22 is unstable at rated frequency with no load:
  - a. Replace regulator.
  - b. Bench test the regulator; see Bench Test.

## c Bench Test

**NOTE:** Before making a warranty claim, use this Bench Test procedure to check VR3 regulators.

**NOTE:** The 4C4693 Regulator Tester with NEHS0535 Operating Manual is available for bench testing regulators. The following procedure is an alternate method of bench testing regulators.

Tools Needed		
4C4029	Trimmer Adjust Tool	1
	Bench Test Circuit	1

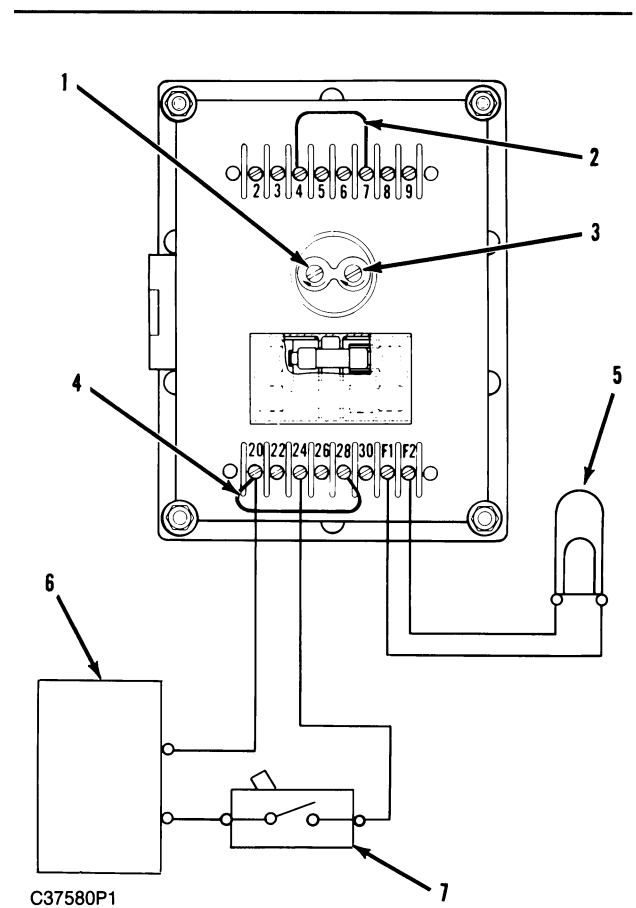

Bench Test Circuit

- (1) Voltage level rheostat. (2) Jumper - remote voltage control. (3) Voltage gain rheostat. (4) Jumper - single phase sensing. (5) 100W Light bulb. (6) AC power source. (7) On/Off switch.

1. Construct and connect the bench test circuit.
2. Install jumper (4). This sets the regulator for the required single phase sensing. Install jumper (2). Jumper (2) is always present unless a remote voltage control is attached.
3. Turn switch (7) to the OFF position. AC power source (6) must be:
 

60 Hz units .....	220 to 240 VAC
50 Hz units .....	180 to 200 VAC
4. Remove protective screws from rheostats (1) and (3).
5. Turn voltage level rheostat (1) and voltage gain rheostat (3) counterclockwise until the rheostat ratchets.

**NOTE:** Voltage level rheostat (1) and voltage gain rheostat (3) are multiple turn rheostats. The adjusting screw on the rheostat does not have a fixed stop. When the rheostat reaches the end of adjustment, a ratchet action begins; this can be felt with the adjusting tool. The adjusting screw can be turned past the rheostat stop (ratchet action) without further changing the rheostats setting.

6. Turn switch (7) to the ON position.

**NOTE:** If an isolation or step-down transformer is used between AC power source (6) and the regulator, it must have sufficient capacity. Measure the AC voltage between terminals 20 and 24 of the regulator. If this voltage changes more than 0.5 ACV when light (5) turns ON, a bigger transformer is required.

7. Turn voltage level rheostat (1) clockwise until light (5) first turns ON (approximately ten turns). The light should increase and decrease in intensity as rheostat (1) is turned clockwise and counterclockwise respectively. After 10 to 15 seconds at maximum intensity, light (5) should go OFF.

- If light (5) operates as described:  
Regulator is okay.

**NOTE:** To retest the regulator, if light (5) operated as described, turn switch (7) to the OFF position for 15 seconds. If this is not done light (5) will not turn back ON.

- If light (5) reacts other than described:  
Replace VR3 regulator.

# Attachments

## Remote Voltage Control

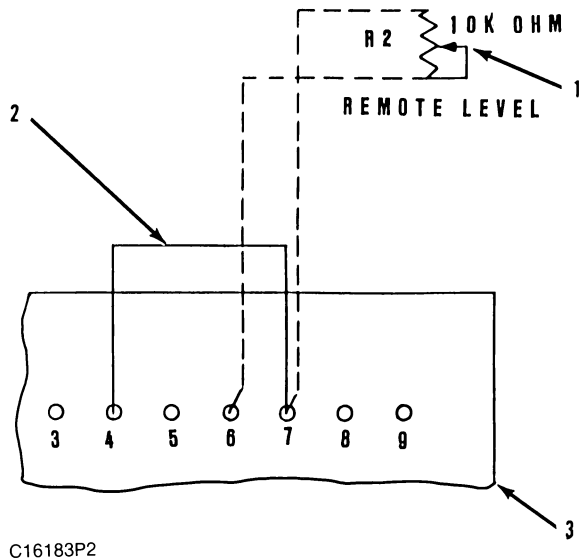

Partial View Of Regulator  
(1) Potentiometer. (2) Jumper. (3) Regulator.

Generator output voltage level can be controlled from a remote location. This is done by connecting potentiometer (1) between terminals (6 and 7) on voltage regulator (3).

### **Remove jumper (2) between terminals (4 and 7) for remote voltage level control.**

For acceptable voltage control, the remote mounted potentiometer must be 10k ohms  $\pm$  5% with three turns and a dielectric strength of 1000 VAC minimum.

The terminals of the remote mounted potentiometer are fragile. The wiring connected to remote mounted potentiometer (1) should not have a diameter larger than 18 gauge. Larger diameter wire is not recommended. The wire should be 600 volt class with a 90°C (194°F) insulation.

**NOTE:** Either jumper (2) or remote potentiometer (1) is required for regulator operation.



**C Series Boost Schematic With Current Two Fuse VR3**

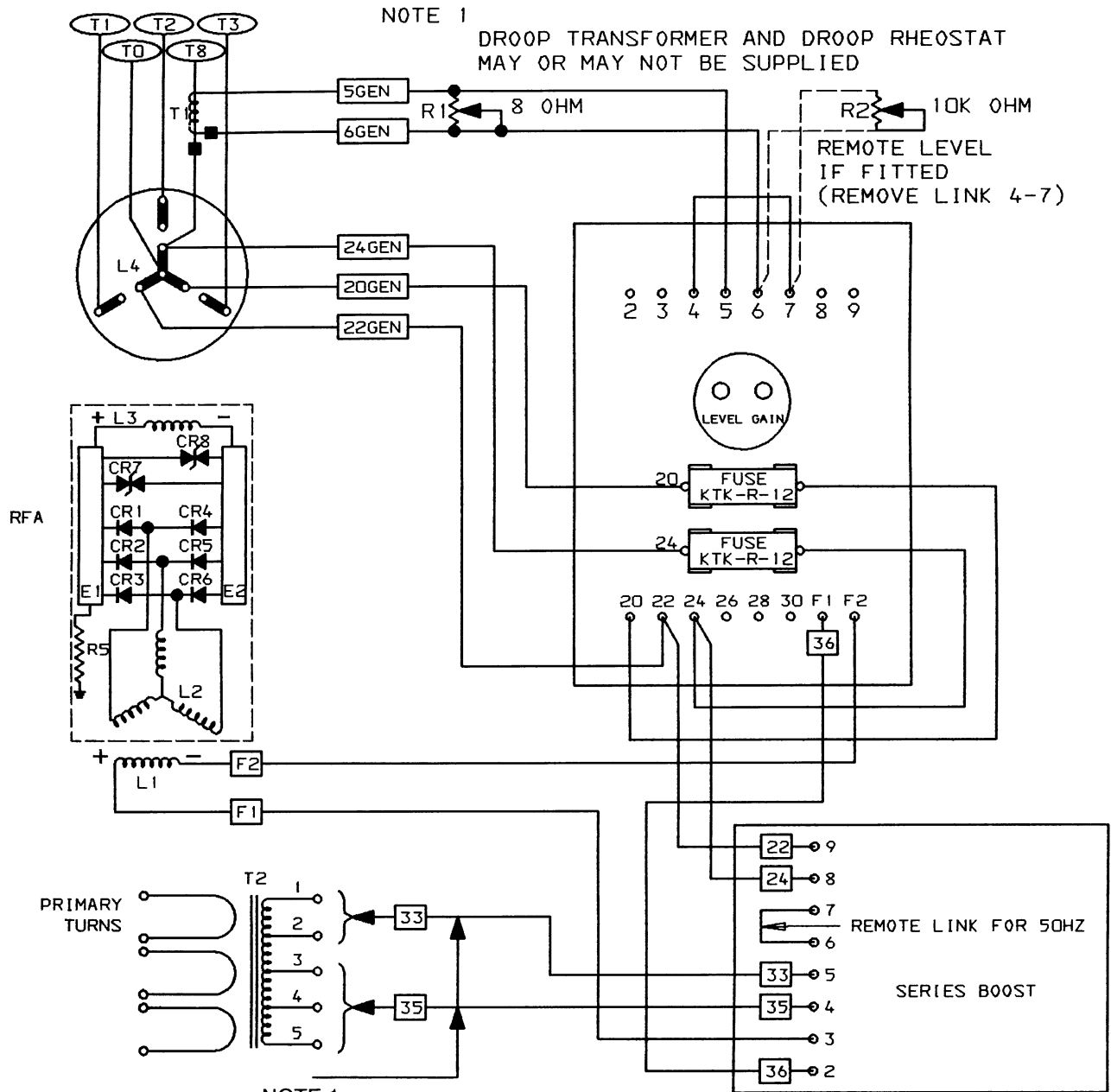

SR-4 GENERATOR SCHEMATIC (10/12 LEAD, SELF-EXCITED, 2 FUSE TYPE, & SERIES BOOST)

NOTE 1: FOR CONNECTIONS; SEE SPECIAL INSTRUCTION FORM SELS0071, SERIES BOOST ATTACHMENT FOR SR4 GENERATORS

C37585P1

Series boost lets self-excited SR4 generators stay on the line, for approximately 10 seconds, when there is a short in the generating or load circuits. This gives circuit breakers a chance to trip in sequence. When circuit breakers trip in sequence, there is less chance for a loss of power to all of the electrical system.

Series boost consists of the series boost module and current transformer T2.

**REFERENCE:** For the most current information on connecting to the primary side of the transformer, see Special Instructions, SELS0071.

Voltage sensing and power are applied to the series boost module from the voltage sensing terminals 22 and 24 of the regulator.

When the sensed voltage is within normal limits, an electrical signal is sent to the gate of a triac located in the series boost module. This triac short circuits the current transformer T2. This prevents any series boost during normal operation.

If there is a short circuit that causes the voltage at the regulator sensing terminals to drop to a low value, the control signal to the gate of the triac will be turned off. Current from current transformer T2 will be rectified and applied directly to exciter stator L1. This field current will be enough to give at least three times full load current into a short circuit. After approximately ten seconds a timer within the series boost module will again cause a control signal to be applied to the gate of the triac. The triac will short circuit the current transformer T2. Current flow to exciter stator L1 will be zero until the short circuit is corrected.

# Manual Voltage Control

## C Manual Voltage Control Schematic With Earlier One Fuse VR3

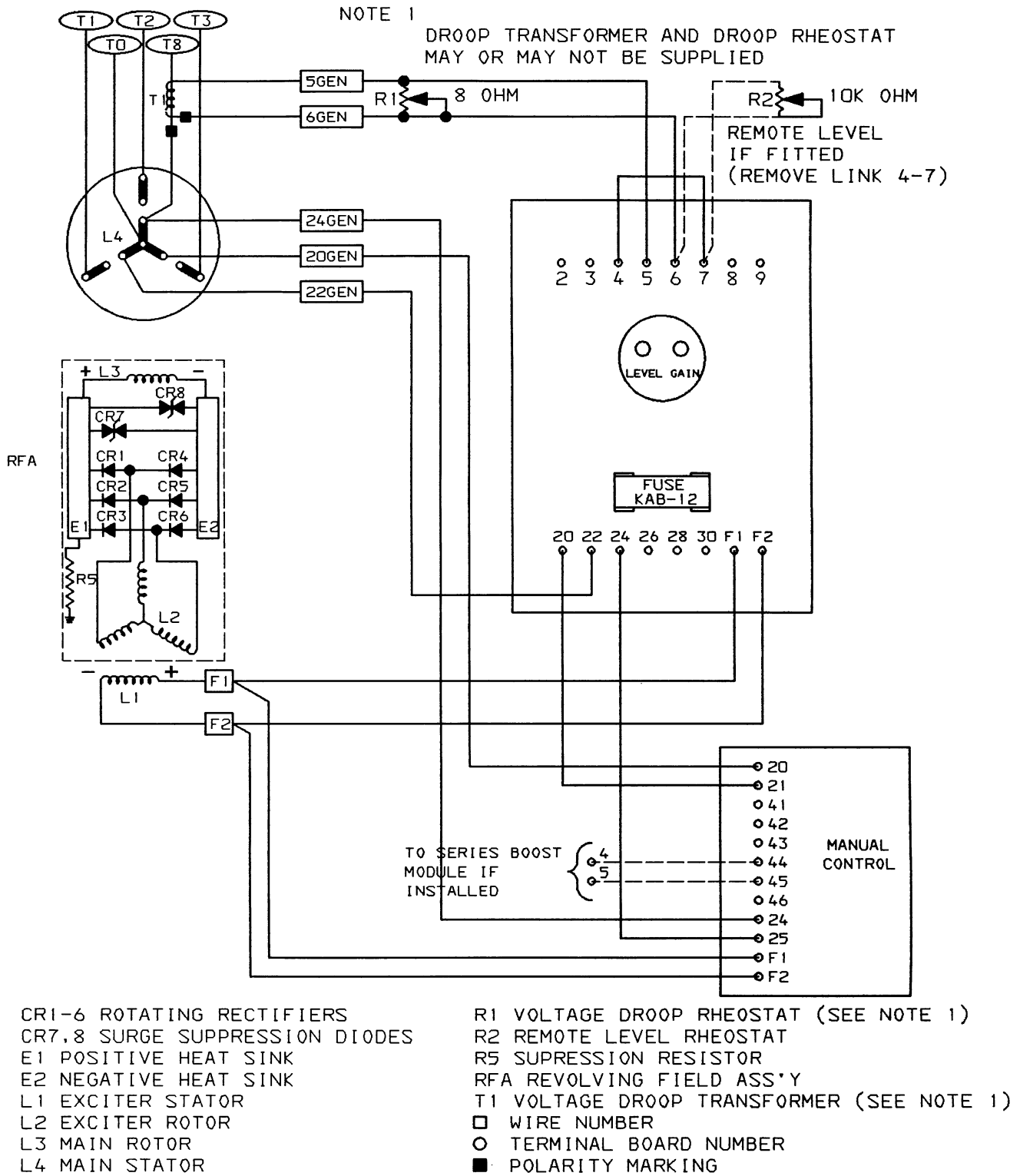

SR-4 GENERATOR SCHEMATIC (10/12 LEAD, SELF-EXCITED, 1 FUSE TYPE, & MANUAL CONTROL)

C37586P1

### C Manual Voltage Control Schematic With Current Two Fuse VR3

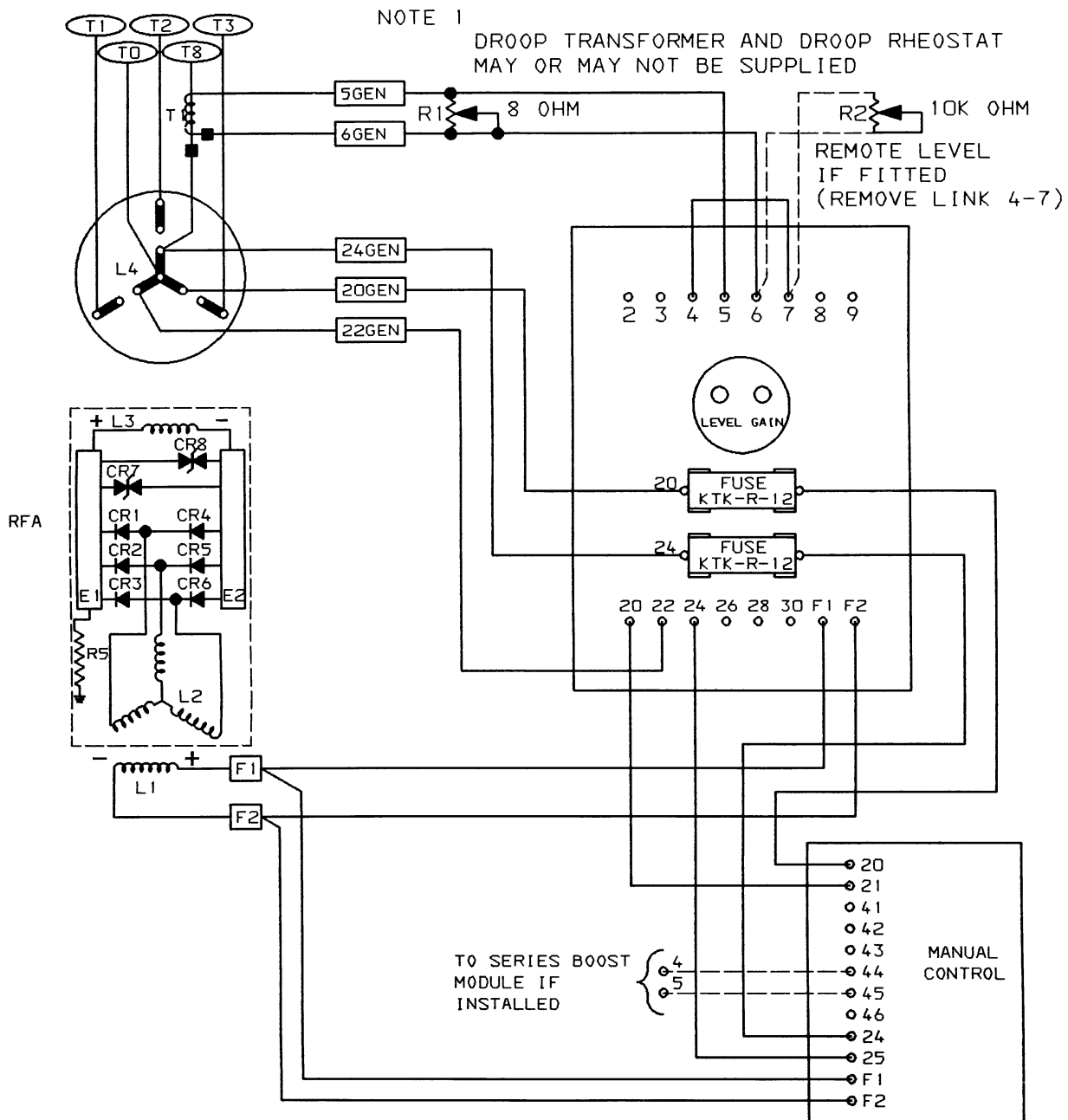

CR1-6 ROTATING RECTIFIERS  
CR7,8 SURGE SUPPRESSION DIODES  
E1 POSITIVE HEAT SINK  
E2 NEGATIVE HEAT SINK  
L1 EXCITER STATOR  
L2 EXCITER ROTOR  
L3 MAIN ROTOR  
L4 MAIN STATOR

R1 VOLTAGE DROOP RHEOSTAT (SEE NOTE 1)  
R2 REMOTE LEVEL RHEOSTAT  
R5 SUPPRESSION RESISTOR  
RFA REVOLVING FIELD ASS'Y  
T1 VOLTAGE DROOP TRANSFORMER (SEE NOTE 1)  
□ WIRE NUMBER  
○ TERMINAL BOARD NUMBER  
■ POLARITY MARKING

SR-4 GENERATOR SCHEMATIC (10/12 LEAD, SELF-EXCITED, 2 FUSE TYPE,  
& MANUAL CONTROL)

C37587P1

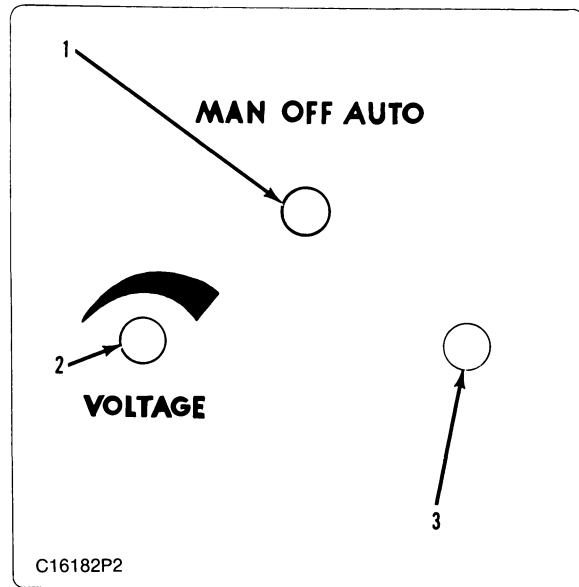

**Manual Voltage Control Panel**

(1) Switch (OFF, AUTO and MAN positions). (2) Voltage control rheostat. (3) Fuse.

The manual voltage control can be used to control generator voltage when there is a failure in the generator regulator assembly. It will manually control the current flow to exciter stator L1.

The manual voltage control panel has switch (1) and voltage control rheostat (2) for the manual operating mode.

Switch (1) is used to make the selection between AUTO, MAN and OFF. In the "AUTO" position, the VR3 regulator controls the generator voltage. In the "OFF" position, the voltage will go to zero. In the "MAN" position, generator voltage is controlled by voltage control rheostat (2) on the manual voltage control panel.

**NOTE:** The Manual Voltage Control Panel must not be installed in a location that is subject to engine vibrations or directly to outside weather.

**NOTE:** When the manual voltage control is operating in the "Manual" mode, it is not necessary for the VR3 regulator to be connected to the generator. However, the manual control must remain connected to generator sensing lines No. 20 and No. 24.

# Voltage Droop Transformer And Adjustment Rheostat For Parallel Operation

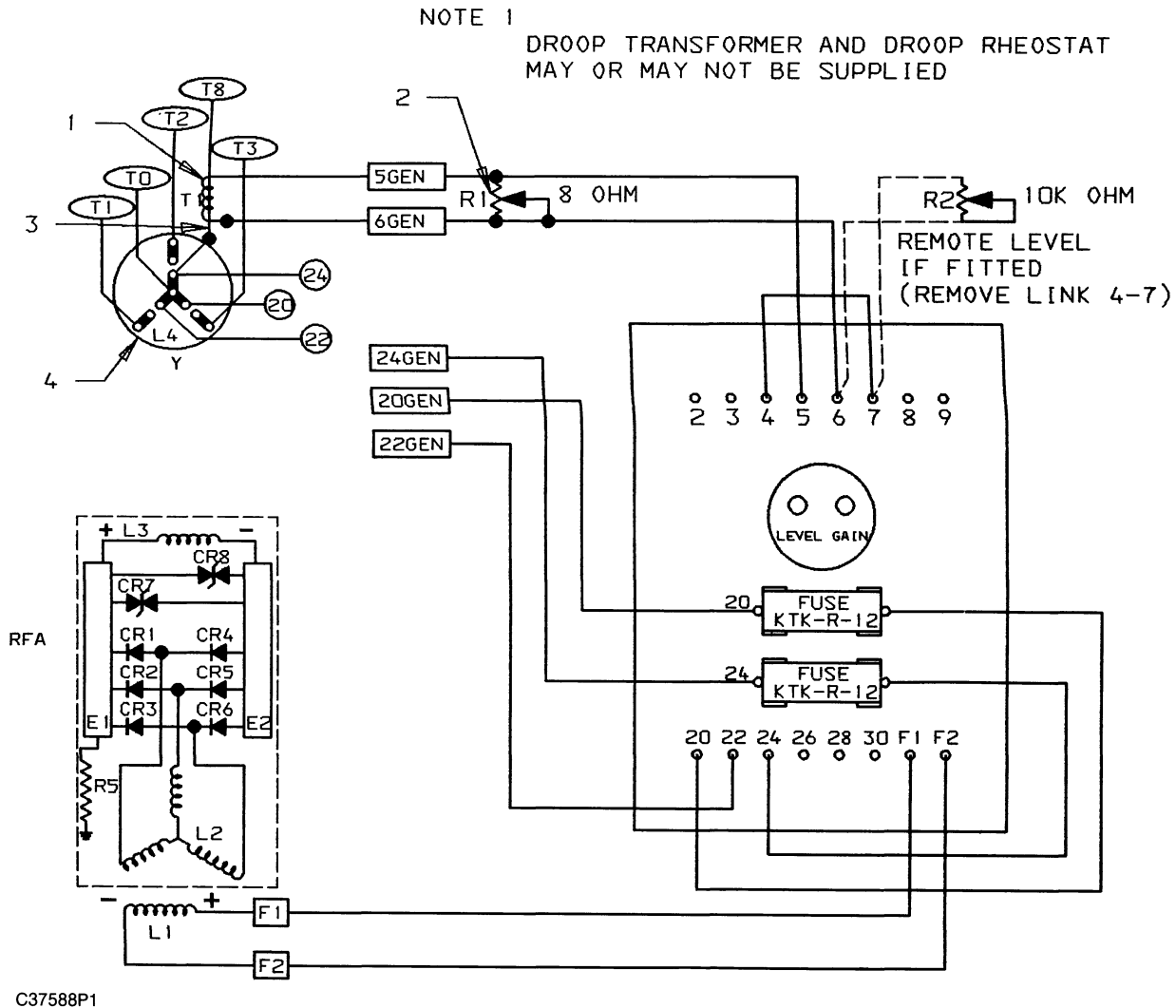

Generator And Regulator Schematic  
(1) Voltage droop transformer. (2) Voltage droop rheostat. (3) Lead. (4) Main stator.

Operation of generators in parallel requires voltage droop as reactive load is increased. Droop transformer (1) and adjustment rheostat (2) are required to provide the voltage droop function. The transformer senses load current in lead (3) of main stator (4). Droop rheostat (2) provides adjustment of droop voltage. Rheostat (2) is located directly next to the regulator on the regulator mounting bracket.

Transformer (1) and rheostat (2) are standard on some generators and an attachment on others.

**NOTE:** Droop transformer (1) must be installed on generator phase lead T8, for 10/12 lead generators with transformer polarity connections as shown.

**NOTE:** Droop Transformer (1) is a special ratio transformer.

# Single Phase Sensing

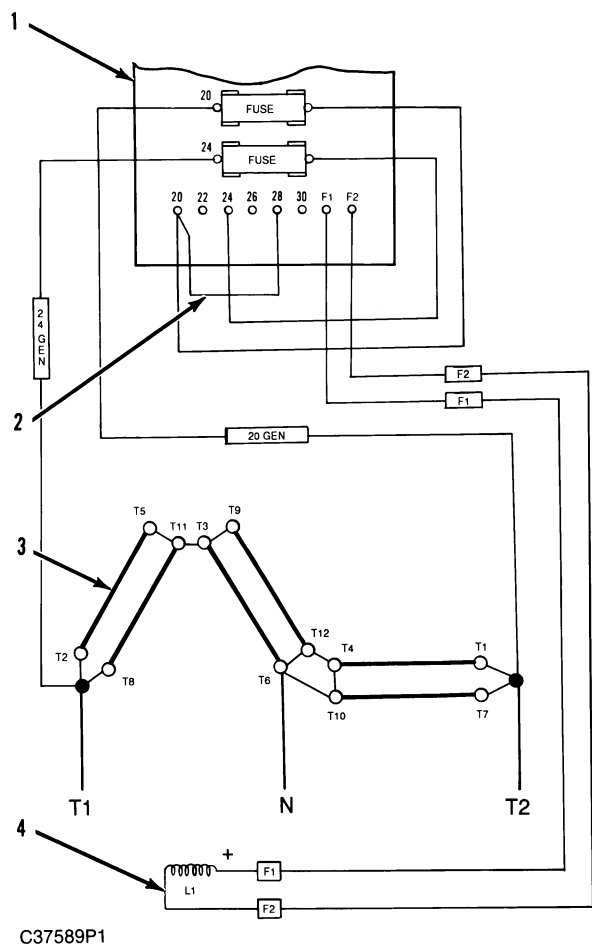

Connection Diagram For Single Phase Sensing  
 (1) VR3 regulator. (2) Jumper. (3) Main stator. (4) Exciter stator.

VR3 regulator (1) can be reconnected for single phase voltage sensing. This is used for special operations such as operating single phase loads with an open delta stator connection.

One sensing lead is disconnected [lead 22 in the illustration]. Then jumper (2) must be provided between terminals 20 and 28 on the voltage regulator.

**CATERPILLAR®**