



FORM NO. SENR3904-01

FOR USE IN SERVICE MANUAL:
ELECTRIC SET GENERATORS, SENR7958

Service Manual

**VR3 Voltage Regulator
4/6 Lead, Self-Excited
SR4 Generators**

Important Safety Information

Most accidents involving product operation, maintenance and repair are caused by failure to observe basic safety rules or precautions. An accident can often be avoided by recognizing potentially hazardous situations before an accident occurs. A person must be alert to potential hazards. This person should also have the necessary training, skills and tools to perform these functions properly.

Improper operation, lubrication, maintenance or repair of this product can be dangerous and could result in injury or death.

Do not operate or perform any lubrication, maintenance or repair on this product, until you have read and understood the operation, lubrication, maintenance and repair information.

Safety precautions and warnings are provided in this manual and on the product. If these hazard warnings are not heeded, bodily injury or death could occur to you or other persons.

The hazards are identified by the "Safety Alert Symbol" and followed by a "Signal Word" such as "WARNING" as shown below.



The meaning of this safety alert symbol is as follows:

Attention! Become Alert! Your Safety is Involved.

The message that appears under the warning, explaining the hazard, can be either written or pictorially presented.

Operations that may cause product damage are identified by NOTICE labels on the product and in this publication.

Caterpillar cannot anticipate every possible circumstance that might involve a potential hazard. The warnings in this publication and on the product are therefore not all inclusive. If a tool, procedure, work method or operating technique not specifically recommended by Caterpillar is used, you must satisfy yourself that it is safe for you and others. You should also ensure that the product will not be damaged or made unsafe by the operation, lubrication, maintenance or repair procedures you choose.

The information, specifications, and illustrations in this publication are on the basis of information available at the time it was written. The specifications, torques, pressures, measurements, adjustments, illustrations, and other items can change at any time. These changes can affect the service given to the product. Obtain the complete and most current information before starting any job. Caterpillar dealers have the most current information available. For a list of the most current publication form numbers available, see the Service Manual Contents Microfiche, REG1139F.

Index

Systems Operation

Introduction	4
Operation	4

Testing And Adjusting

C Bench Test	12
C Schematics – 4/6 Pole Self-Excited Generators	7
Test Equipment	6
Troubleshooting	9
Introduction	9
C Problem 1 - No AC Voltage	9
Problem 2 - Low AC Voltage	11
Problem 3 - High AC Voltage	11
Problem 4 - Unstable AC Voltage	12
Problem List	9

Attachments

Manual Voltage Control	15
Remote Voltage Control	14
Voltage Droop Transformer And Adjustment Rheostat For Parallel Operation	18

A "C" in the left margin is an indication of a change from the former issue.

Systems Operation

Introduction

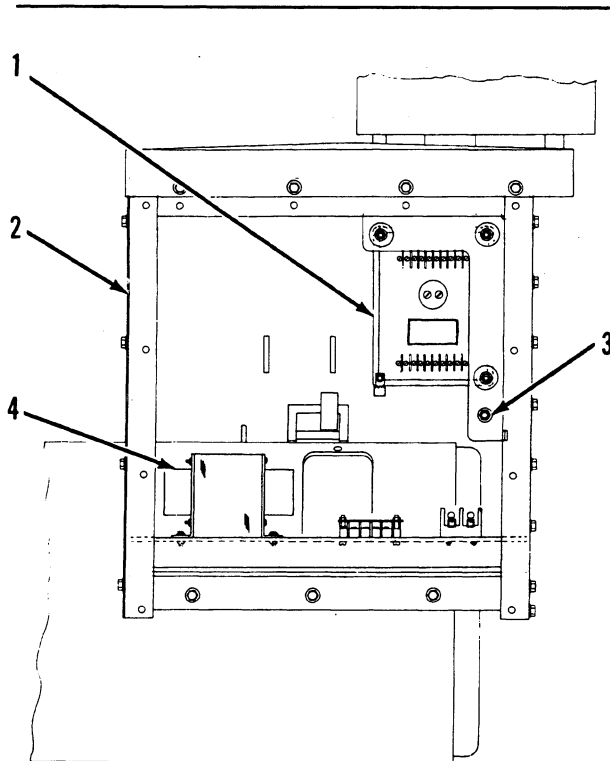

C37578P1

SR4 Generator (Partial View)

(1) VR3 regulator. (2) Terminal box. (3) Droop rheostat location. (4) Power transformer PT2.

This manual covers the VR3 voltage regulator as it is used on 4/6 lead, self-excited SR4 generators. This manual must be used in conjunction with service manual Electric Set Generators SENR7958 and Operation and Maintenance Manual SEBU6150.

Follow all safety procedures and warnings in the above generator manuals.

VR3 regulator (1) is located in generator terminal box (2).

Operation

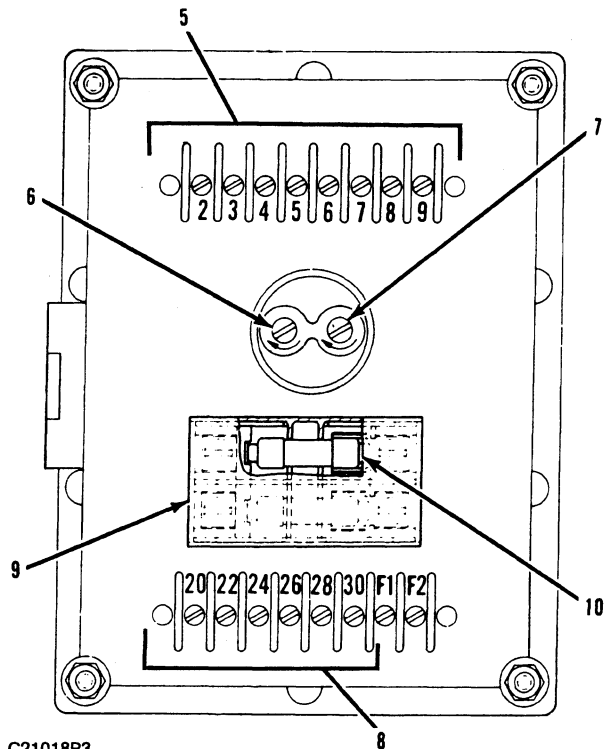

C21018P3

VR3 Regulator

(5) Terminal strip (for attachments). (6) Rheostat (voltage level). (7) Rheostat (voltage gain). (8) Terminal strip (for sensing and power). (9) Fuse cover. (10) Fuses.

The purpose of the VR3 regulator is to keep generator output voltage at a rated value. There are two controls on the VR3 that are standard.

- Voltage level rheostat (6) provides a no load voltage adjustment of approximately +10 to -25%.
- Voltage gain rheostat (7) provides an adjustment to compensate for engine RPM droop with load. Rheostat (7) can be adjusted to keep the same voltage at no load and full load, even when there is a small change in frequency (rpm).

Rheostats (6) and (7) are multiple turn. They do not have a fixed stop at the end of travel, but have an override ratchet.

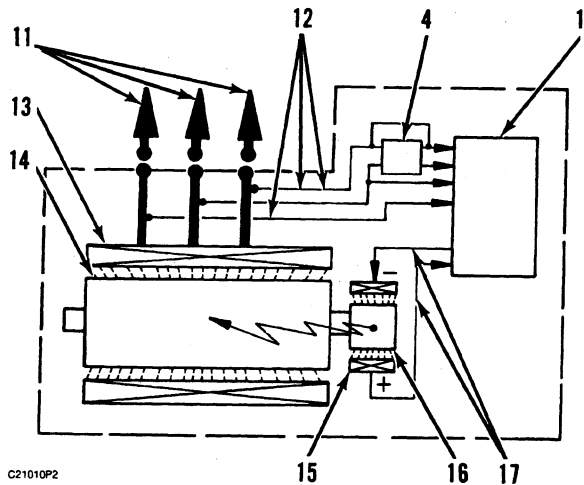

C21010P2

SR4 Generator Schematic (Self-excited 4/6 lead)
 (1) VR3 regulator. (4) Power transformer PT2. (11) Lines - 3 phase output voltage. (12) Lines - sensing voltage and AC power. (13) Main stator. (14) Main rotor. (15) Exciter stator. (16) Exciter rotor. (17) Lines - VDC excitation voltage.

VR3 regulator (1) uses all three phases to sense generator output voltage. Lines (12) function as sensing lines by tapping into generator output and connecting to terminals 20, 22 and 24 (AC input) on terminal strip (8). Like other SR4 generator regulators, the VR3 regulates voltage based on volts per hertz. The VR3 offers an approximate 8 volts per hertz characteristic.

Wires 20 and 24, of lines (12), are used to provide AC power to step-down power transformer PT2 (4). PT2 will step-down the AC voltage to 240 VAC for excitation to the VR3 regulator. The regulator rectifies the AC voltage and controls the excitation current to exciter stator (15).

Two fuses, in secondary output wires 30 and 31 of PT2, limit the field current in the case of an internal short circuit or loss of sensing signal.

NOTE: VR3 regulators include an overcurrent shutoff to protect generator components. If the unit operates for an extended period of time at low rpm, the overcurrent shutoff may trip. It will reset automatically when the generator is completely shutoff. For 60 Hz generator operation, the recommended minimum operating speed is:

- Four pole 1200 rpm
- Six pole 800 rpm

NOTE: VR3 regulators are sensitive to A-B-C phase rotation. Connections must be as shown in this manual; T1 to 22, T2 to 24, and T3 to 20.

C NOTE: If it is required to provide a shutoff for the VR3 regulator, connect a SPDT switch (rated 20 amp, 240 volt) in:

- Line 30 - for generator sets with a power transformer only.
- Line 24 - for generator sets with sensing and power transformers.

Testing And Adjusting

WARNING

When servicing or repairing electric power generation equipment, do the following:

- Make sure the unit is off-line (disconnected from utility and/or other generators power service), and either locked out or tagged "DO NOT OPERATE".
- Make sure the generator engine is stopped.
- Make sure all batteries are disconnected.
- Make sure all capacitors are discharged.

When power generation equipment must be in operation to make tests and/or adjustments, high voltage and current are present. Make sure the testing equipment is designed for and correctly operated for the high voltage and current tests being made. Improper test equipment may fail and present a high voltage shock hazard to its user.

WARNING

Do not connect the generator to a utility electrical distribution system, unless it is isolated from the system. Electrical feedback into the distribution system can occur and could cause personal injury or death.

Open and secure the main distribution system switch or, if the connection is permanent, install a double throw transfer switch to prevent electrical feedback. Some generators are specifically approved by a utility to run in parallel with the distribution system and isolation may not be required. Always check with your utility as to the applicable circumstances.

Test Equipment

C37282P1

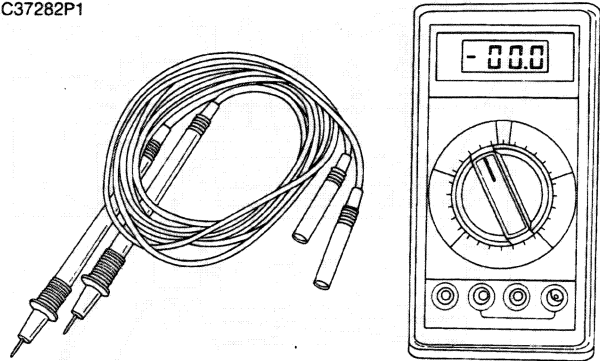

6V7070 Heavy Duty Digital Multimeter

Caterpillar Digital Multimeters measure voltage, resistance, or current up to 10 amps. The diode function checks rectifiers. See Special Instruction SEHS7734 for the operation of 6V7070.

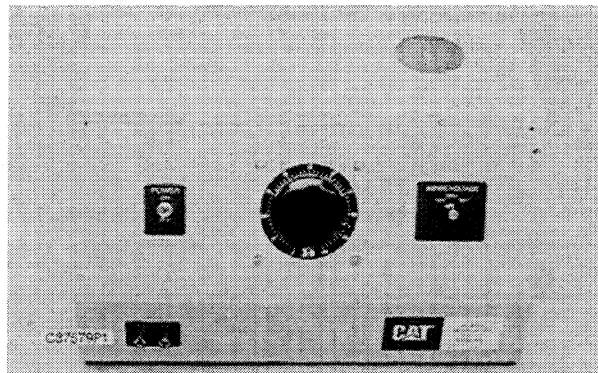

4C4693 Regulator Tester

The 4C4693 Regulator Tester is a bench top instrument used to test VR3 regulators. This provides a way to check a regulator without using a generator set.

c Schematics - 4/6 Lead Self-Excited Generators

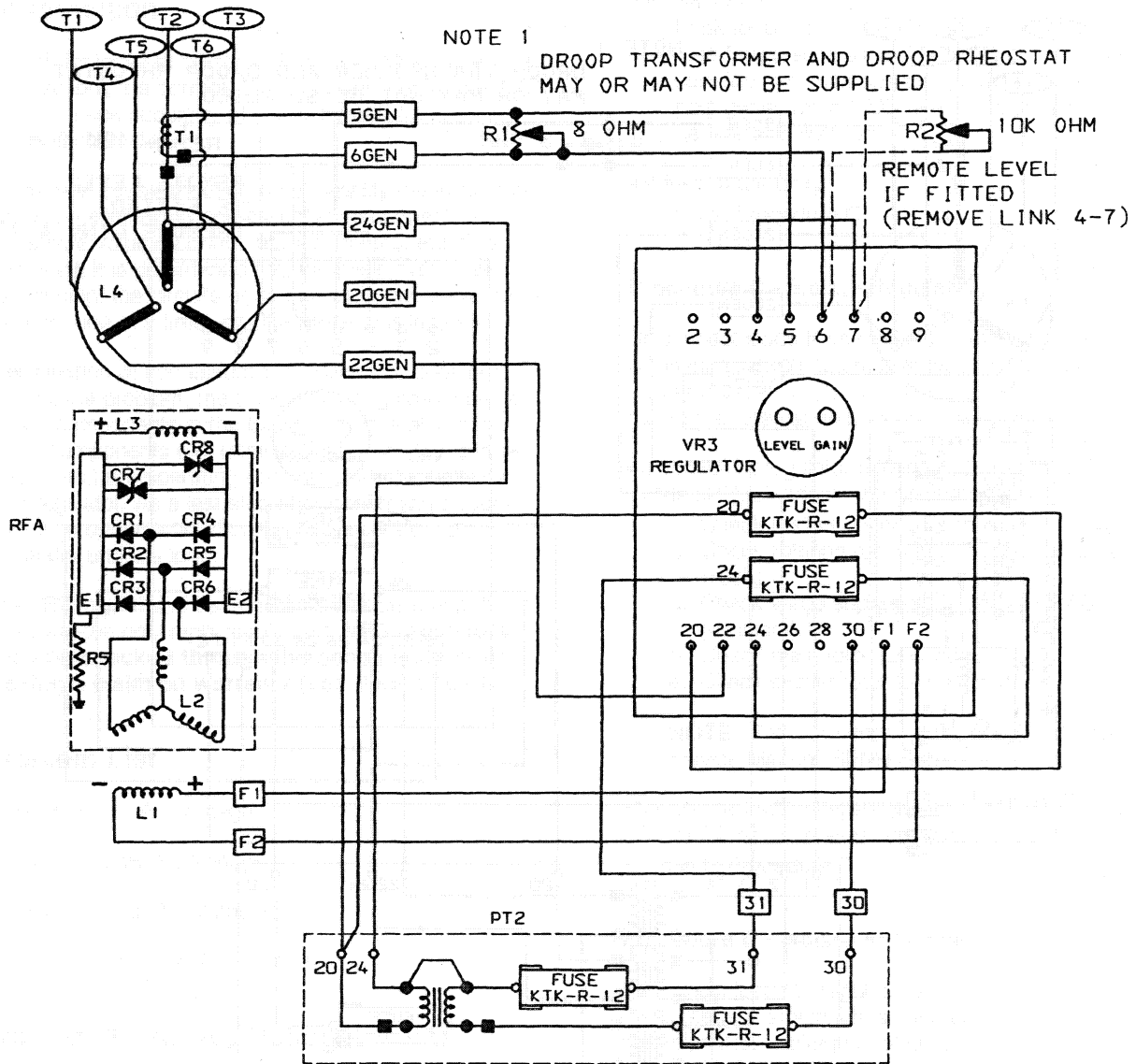

CR1-6 ROTATING RECTIFIERS
CR7,8 SURGE SUPPRESSION DIODES
E1 POSITIVE HEAT SINK
E2 NEGATIVE HEAT SINK
L1 EXCITER FIELD
L2 EXCITER ARMATURE
L3 ROTATING FIELD
L4 STATOR

R1 VOLTAGE DROOP RHEOSTAT (SEE NOTE 1)
R2 REMOTE LEVEL RHEOSTAT
R5 SUPPRESSION RESISTOR
RFA REVOLVING FIELD ASS'Y
T1 VOLTAGE DROOP TRANSFORMER (SEE NOTE 1)
PT2 POWER TRANSFORMER ASSEMBLY
O TERMINAL BOARD NUMBER
□ WIRE NUMBER
■ POLARITY MARKING

SR-4 GENERATOR SCHEMATIC (4/6 LEAD, SELF-EXCITED W/ POWER TRANSFORMER)

NOTE : GENERATOR STATOR LEADS TERMINALS T4, T5, AND T6 WILL BE INTERNALLY CONNECTED TO FORM THE NEUTRAL LEAD (T0) ON FOUR LEAD GENERATORS.

C37573P1

VR3 With Power Transformer And Sensing

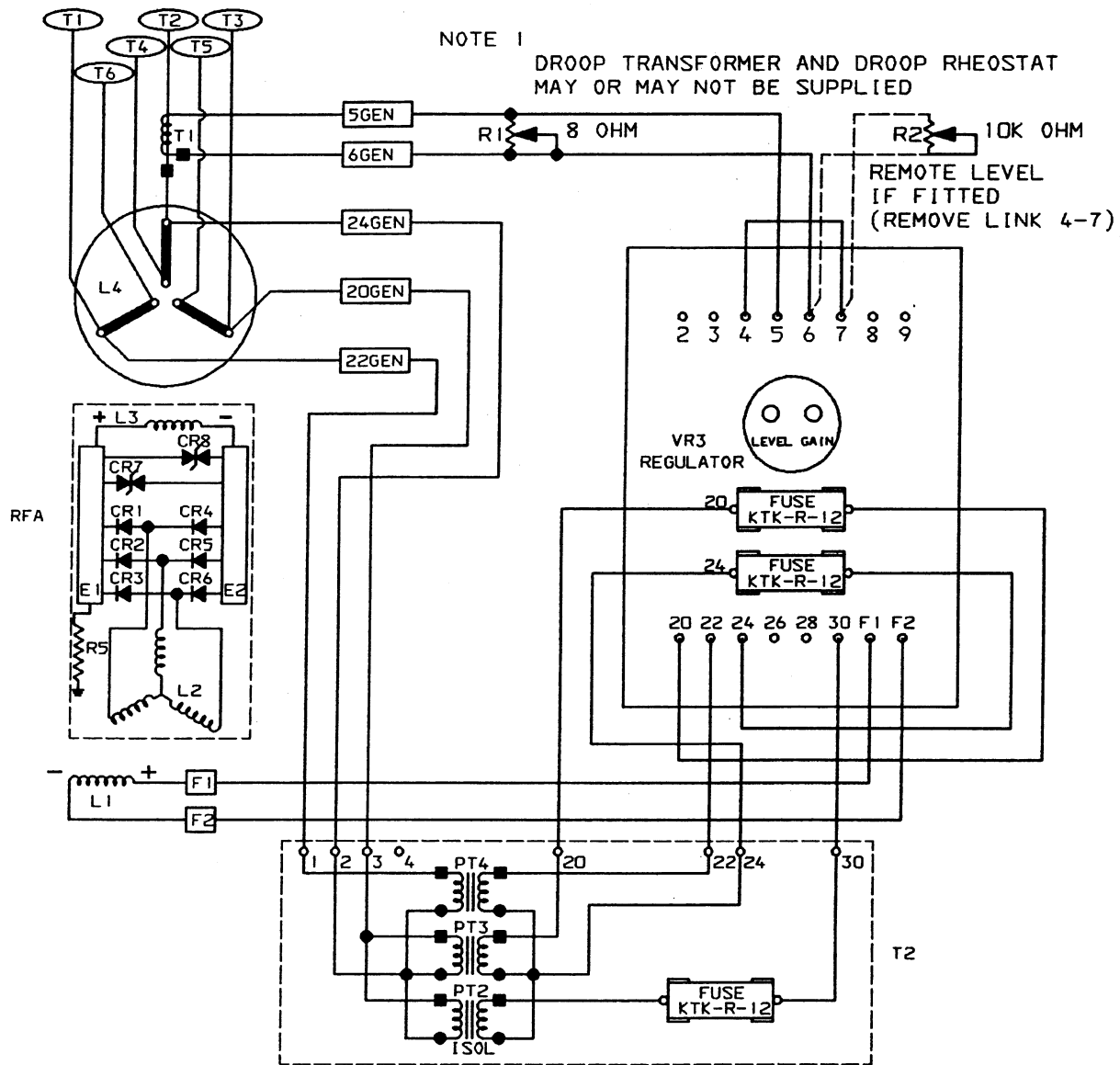

NOTE 1
DROOP TRANSFORMER AND DROOP RHEOSTAT
MAY OR MAY NOT BE SUPPLIED

R2 10K OHM
REMOTE LEVEL
IF FITTED
(REMOVE LINK 4-7)

- CR1-6 ROTATING RECTIFIERS
- CR7,8 SURGE SUPPRESSION DIODES
- E1 POSITIVE HEAT SINK
- E2 NEGATIVE HEAT SINK
- L1 EXCITER FIELD
- L2 EXCITER ARMATURE
- L3 ROTATING FIELD
- L4 STATOR
- PT2 POWER TRANSFORMER
- PT3,4 SENSING TRANSFORMER
- R1 VOLTAGE DROOP RHEOSTAT (SEE NOTE 1)
- R2 REMOTE LEVEL RHEOSTAT
- R5 SUPPRESSION RESISTOR
- RFA REVOLVING FIELD ASS'Y
- T1 VOLTAGE DROOP TRANSFORMER (SEE NOTE 1)
- T2 ISOLATION TRANSFORMER ASSEMBLY
- TERMINAL BOARD NUMBER
- WIRE NUMBER
- POLARITY MARKING

SR-4 GENERATOR SCHEMATIC (4/6 LEAD, SELF-EXCITED W/ SENSING AND POWER TRANSFORMER)

NOTE : GENERATOR STATOR LEADS TERMINALS T4, T5, AND T6 WILL BE INTERNALLY CONNECTED TO FORM THE NEUTRAL LEAD (TO) ON FOUR LEAD GENERATORS.

C37574P1

Troubleshooting

Introduction

Check for loose or corroded terminals. Make sure wire connections are correct. Check power transformer PT2 fuses. Check accuracy of voltmeter and frequency meter/tachometer.

To reduce troubleshooting time, simplify the system or circuit by eliminating non-essential components such as remote voltage control, manual control, etc. If, at this point, it is determined that the basic system is functioning, the circuits or components can be added back in, one at a time until the problem is located.

If elimination of non-essential components does not correct the problem, the troubleshooting procedure will check components in the basic system. If all other basic components (i.e. rotating field assembly, exciter stator, etc.) are operating correctly, then replace the VR3 regulator. As a last step after confirming correct operation under no load conditions, operate the generator under a load.

The VR3 regulator is serviced as a complete unit. Its fuses are the only replaceable part. **VR3 regulators must be checked through the bench test before making a claim on warranty (see Bench Test).**

Problem List

Problem 1 - No AC Voltage.

Problem 2 - Low AC Voltage.

Problem 3 - High AC Voltage.

Problem 4 - Unstable AC Voltage.

C Problem 1 - No AC Voltage

Procedure A - Check AC Voltage At Regulator Between Terminals 20 And 22

- If above 390 volts:
Check meters.
- If 0 volts:
Flash the field; see SR4 Generator Service Manual, SENR3985.
- If 0 to 15 volts:
Go to Procedure B.

Procedure B - Check Power Transformer PT2 Fuses

- If fuse(s) have failed:
Look for possible short circuits that could cause fuse failure such as shorted field L1, etc. Make sure the minimum operating speed for the four pole generator is 1200 rpm or the six pole generator is 800 rpm.
- If fuse(s) are okay:
Go to Procedure C.

Procedure C - Isolate Regulator

Disconnect leads from regulator terminals F1 and F2. Connect a 12 volt automotive type battery across exciter leads F1 (+) and F2 (-). Operate generator at half of the rated speed. Then slowly increase rpm.

- If voltage at regulator terminals 20 and 22 is 0 to 15 volts (AC), shutdown the generator and:
 - a. Check exciter stator L1 continuity.
 - b. Check rotating rectifiers CR1-6 (rotating rectifier block).
 - c. Check surge suppression diodes CR7-8 (varistors).
 - d. Check main rotor L3 continuity.
 - e. Check exciter rotor L2 continuity.

NOTE: For more information, see SR4 Generator Service Manual, SENR3985.

- If balanced AC voltage between regulator terminals 20-22-24 that increases with rpm:
Go to Procedure D.

Procedure D - Isolate Attachments

Reconnect leads to regulator terminals F1 and F2. Disconnect all attachments such as manual voltage control, remote voltage control, droop transformer, etc. Do not disconnect the power transformer PT2.

NOTE: If remote mounted voltage adjustment is disconnected, connect jumper across terminals 4 and 7.

Check all connections to regulator and the power transformer fuses.

- If generator output voltage is normal:
Check attachments.
- If voltage at regulator terminals 20 and 22 is 0 to 15 volts:
Go to Procedure E.

Procedure E - Check Connections And Continuity Of Power Transformer PT2 Wiring

Remove PT2 secondary fuses. Check continuity of secondary fuses.

Isolate PT2. Disconnect wire 20GEN, from PT2 terminal 20.

Check continuity of wires 20GEN and 24GEN from PT2 to stator L4.

Check wire 30 continuity; from the wire 30 secondary fuse to the transformer.

Check wire 31 continuity; from the wire 31 secondary fuse to the transformer.

Check continuity of wire 30; from wire 30 fuse to regulator terminal 30.

Check continuity of wire 31; from wire 31 fuse to regulator terminal 24.

- If no continuity:
Repair or replace wires or fuses.
- If continuity is okay:
Go to Procedure F.

Procedure F - Power Transformer PT2 Typical Resistances

POWER TRANSFORMER (PT2) TYPICAL WINDING RESISTANCE ¹			
Generator	PT2 Terminals 20 - 24 (Primary)	PT2 Terminals 30 - 31 (Secondary)	PT2 Terminals 24 - 31
480V			
Min	2.0 Ω	.8 Ω	0 Ω
Max	3.3 Ω	1.3 Ω	0 Ω
600V			
Min	3.4 Ω	1.2 Ω	0 Ω
Max	4.8 Ω	1.9 Ω	0 Ω

¹ PT2 must be isolated.

Reinstall the PT2 secondary fuses. Wire 20GEN remains disconnected. Disconnect VR3 wires 30 and 31 from PT2 terminals 30 and 31.

Measure the primary winding resistance; between terminals 20 and 24.

Measure the secondary winding resistance; between terminals 30 and 31.

The resistances must be as per the Power Transformer PT2 Typical Winding Resistance chart.

- If the resistance measurements are not correct:
Replace PT2.
- If the resistance measurements are correct:
Go to Procedure G.

Procedure G (For VR3 With Power And Sensing) - Check Wiring Connections And Wiring Continuity Of Isolation Transformer Assembly T2

Remove T2 secondary fuse. Check continuity of fuse.

Isolate the isolation transformer assembly T2. Disconnect and isolate wires 20GEN, 22GEN and 24GEN from terminals 1, 2 and 3 of isolation transformer assembly T2. Check continuity of wires 20GEN, 22GEN and 24GEN; from isolation transformer assembly T2 to main stator L4.

Disconnect and isolate wires 20, 22, 24 and 30 from terminals 20, 22, 24 and 30 of T2. Check continuity of wires 20, 22, 24 and 30; from the isolation transformer assembly T2 to VR3 terminals.

- If no continuity:
Repair or replace wires or fuse.
- If continuity is okay:
Go to Procedure H.

Procedure H - Isolation Transformer Assembly T2 Typical Resistances

ISOLATION TRANSFORMER ASSEMBLY T2 TYPICAL WINDING RESISTANCE ¹					
Generator	T2 Terminals 1 - 2	T2 Terminals 2 - 3	T2 Terminals 24 - 20	T2 Terminals 24 - 22	T2 Terminals 24 - 30
480V					
Min	700 Ω	1.5 Ω	460 Ω	460 Ω	.5 Ω
Max	850 Ω	1.7 Ω	500 Ω	500 Ω	.7 Ω
600V					
Min	1150 Ω	2.4 Ω	460 Ω	460 Ω	.5 Ω
Max	1350 Ω	2.7 Ω	500 Ω	500 Ω	.7 Ω

¹ T2 must be isolated.

Reinstall T2 secondary fuse. Wires 20GEN, 22GEN and 24GEN remain disconnected from terminals 1, 2 and 3 of isolation transformer assembly T2. Wires 20, 22, 24 and 30 remain disconnected from terminals 20, 22, 24 and 30.

Check the winding resistance of isolation transformer assembly T2. The resistance must be as per the Isolation Transformer Assembly T2 Typical Winding Resistance chart.

- If the resistance measurements are not correct:
Replace isolation transformer assembly T2.
- If the resistance measurements are correct:
 - a. Replace VR3 regulator.
 - b. Bench test the regulator. See Bench Test.

Problem 2 - Low AC Voltage

Procedure A - Check Engine RPM (Frequency)

Gen. Poles	Frequency	RPM
6	50 Hz.	1000
6	60 Hz.	1200
4	50 Hz.	1500
4	60 Hz.	1800

Procedure B - Adjust Voltage Level With Gain Adjustment Full Counter-Clockwise

The voltage level adjustment range must be within +10 to -25% of rated voltage.

- If the voltage level can not be adjusted as described:
 - a. Check accuracy of voltmeter.
 - b. Go to Procedure C.

Procedure C - Check AC Voltage Between Regulator Terminals 20 And 22

- If greater than approximately 390 volts:
Check meters.
- If lower than 390 volts:
Go to Procedure D.

Procedure D - Isolate Regulator

Disconnect leads from regulator terminals F1 and F2. Connect a 12 volt automotive type battery across exciter leads F1 (+) and F2 (-). Operate generator at half of the rated speed. Then slowly increase RPM.

- If voltage at regulator terminals 20 and 22 is less than 100 volts, shutdown the generator and:
 - a. Check rotating rectifiers CR1-6 (rotating rectifier block).
 - b. Check surge suppression diodes CR7-8 (varistors).

- c. Check exciter stator L1 resistance between F1 and F2 leads. Exciter stator resistance should be approximately 3 to 5 ohms.

NOTE: For more information, see SR4 Generator Service Manual, SENR3985.

- If balanced AC voltage between regulator terminals 20-22-24 that increases with RPM:
Go to Procedure E.

Procedure E - Isolate Attachments

Connect exciter stator L1 leads to regulator terminals F1 and F2. Disconnect all attachments such as manual voltage control, remote voltage control, droop transformer, etc. Do not disconnect power transformer PT2 or isolation transformer assembly T2, if provided.

NOTE: If remote mounted voltage adjustment is disconnected, connect jumper across terminals 4 and 7.

Check all connections to: VR3 regulator, regulator fuses, power transformer PT2 or isolation transformer assembly T2, if provided.

- If generator output voltage is normal:
Check attachments.
- If voltage at regulator terminals 20 and 22 cannot be adjusted to rated voltage and rated frequency at no load:
 - a. Replace regulator.
 - b. Bench test the regulator; see Bench Test.

Problem 3 - High AC Voltage

Procedure A - Check Engine RPM (Frequency)

Gen. Poles	Frequency	RPM
6	50 Hz.	1000
6	60 Hz.	1200
4	50 Hz.	1500
4	60 Hz.	1800

Procedure B - Adjust Voltage Level With Gain Adjustment Full Counter-Clockwise

The voltage level adjustment range must be within +10 to -25% of rated voltage.

- If the voltage level can not be adjusted as described:
 - a. Check accuracy of voltmeter.
 - b. Go to Procedure C.

Procedure C - Check Connections To Regulator

- If connections are correct:
Go to Procedure D.

Procedure D - Isolate Attachments

Disconnect attachments such as manual voltage control, etc. Do not disconnect power transformer PT2 or isolation transformer assembly T2, if provided. Operate at rated rpm.

NOTE: If remote mounted voltage adjustment is disconnected, connect jumper across terminals 4 and 7.

- If generator output voltage is normal:
Check attachments.
- If voltage cannot be adjusted to rated voltage at rated frequency:
 - a. Replace regulator.
 - b. Bench test the regulator; see Bench Test.

Problem 4 - Unstable AC Voltage

Procedure A - Check Engine RPM

- If governor operation is unstable.
 - a. Correct engine problem. Reference engine service manual.
 - b. Go to Procedure B.

Procedure B - Check For Loose Connections

- If connections are okay:
Go to Procedure C.

Procedure C - Isolate Regulator

Disconnect leads F1 and F2 from their respective terminals on the regulator. Connect a 12 volt automotive type battery across exciter leads F1 and F2. Operate at half of rated speed and then slowly increase rpm.

- If voltage at regulator terminals 20-22 is unstable, shutdown the generator and:
 - a. Check connections to rotating rectifiers, main field poles and other connections on the rotating (revolving) field.
 - b. Check connections to exciter stator L1.
- If stable balanced AC voltage between regulator terminals 20-22-24 that increases with rpm:
Go to Procedure D.

Procedure D - Isolate Attachments

Reconnect leads to regulator terminals F1 and F2. Disconnect all attachments such as manual voltage control, remote voltage control, droop transformer, etc. Do not disconnect power transformer PT2 or isolation transformer assembly T2, if provided.

NOTE: If remote mounted voltage adjustment is disconnected, connect jumper across terminals 4 and 7.

Check all connections: VR3 regulator, regulator fuses, power transformer PT2 or isolation transformer assembly T2, if provided.

- If generator output voltage is normal:
Check attachments.
- If voltage at regulator terminals 20-22 is unstable at rated frequency with no load:
 - a. Replace regulator.
 - b. Bench test the regulator; see Bench Test.

c Bench Test

NOTE: Before making a warranty claim, use this Bench Test procedure to check VR3 regulators.

NOTE: The 4C4693 Regulator Tester with NEHS0535 Operating Manual is available for bench testing regulators. The following procedure is an alternate method of bench testing regulators.

Tools Needed		
4C4029	Trimmer Adjust Tool	1
	Bench Test Circuit	1

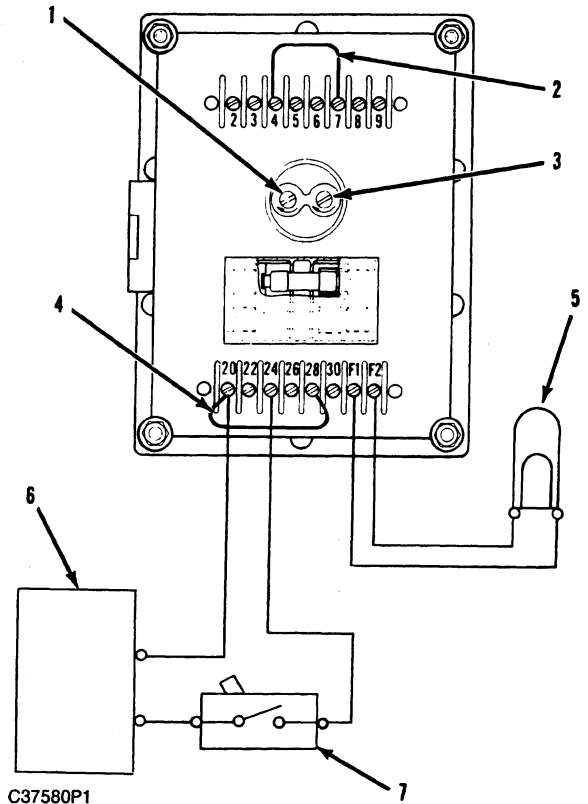

Bench Test Circuit
 (1) Voltage level rheostat. (2) Jumper - remote voltage control.
 (3) Voltage gain rheostat. (4) Jumper - single phase sensing.
 (5) 100W Light bulb. (6) AC power source. (7) On/Off switch.

1. Construct and connect the bench test circuit.
2. Install jumper (4). This sets the regulator for the required single phase sensing. Install jumper (2). Jumper (2) is always present unless a remote voltage control is attached.
3. Turn switch (7) to the OFF position. AC power source (6) must be:
 60 Hz units 220 to 240 VAC
 50 Hz units 180 to 200 VAC
4. Remove protective screws from rheostats (1) and (3).

5. Turn voltage level rheostat (1) and voltage gain rheostat (3) counterclockwise until the rheostat ratchets.

NOTE: Voltage level rheostat (1) and voltage gain rheostat (3) are multiple turn rheostats. The adjusting screw on the rheostat does not have a fixed stop. When the rheostat reaches the end of adjustment, a ratchet action begins; this can be felt with the adjusting tool. The adjusting screw can be turned past the rheostat stop (ratchet action) without further changing the rheostats setting.

6. Turn switch (7) to the ON position.

NOTE: If an isolation or step-down transformer is used between AC power source (6) and the regulator, it must have sufficient capacity. Measure the AC voltage between terminals 20 and 24 of the regulator. If this voltage changes more than 0.5 ACV when light (5) turns ON, a bigger transformer is required.

7. Turn voltage level rheostat (1) clockwise until light (5) first turns ON (approximately ten turns). The light should increase and decrease in intensity as rheostat (1) is turned clockwise and counterclockwise respectively. After 10 to 15 seconds at maximum intensity, light (5) should go OFF.

- If light (5) operates as described:
 Regulator is okay.

NOTE: To retest the regulator, if light (5) operated as described, turn switch (7) to the OFF position for 15 seconds. If this is not done light (5) will not turn back ON.

- If light (5) reacts different than described:
 Replace VR3 regulator.

Attachments

Remote Voltage Control

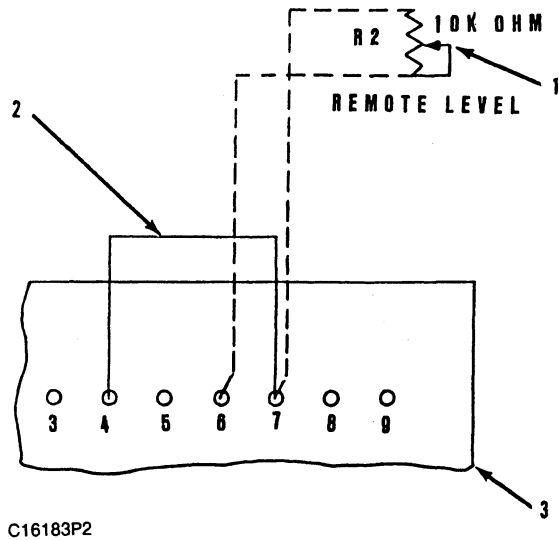

Partial View Of Regulator
(1) Potentiometer. (2) Jumper. (3) Regulator.

Generator output voltage level can be controlled from a remote location. This is done by connecting potentiometer (1) between terminals 6 and 7 on voltage regulator (3).

Remove jumper (2) between terminals 4 and 7 for remote voltage level control.

For acceptable voltage control, the remote mounted potentiometer must be 10k ohms \pm 5% with three turns and a dielectric strength of 1000 VAC minimum.

The terminals of the remote mounted potentiometer are fragile. The wiring connected to remote mounted potentiometer (1) should not have a diameter larger than 18 gauge. Larger diameter wire is not recommended. The wire should be 600 volt class with a 90°C (194°F) insulation.

NOTE: Either jumper (2) or remote potentiometer (1) is required for regulator operation.

Manual Voltage Control

C Manual Voltage Control Schematic With Power Transformer

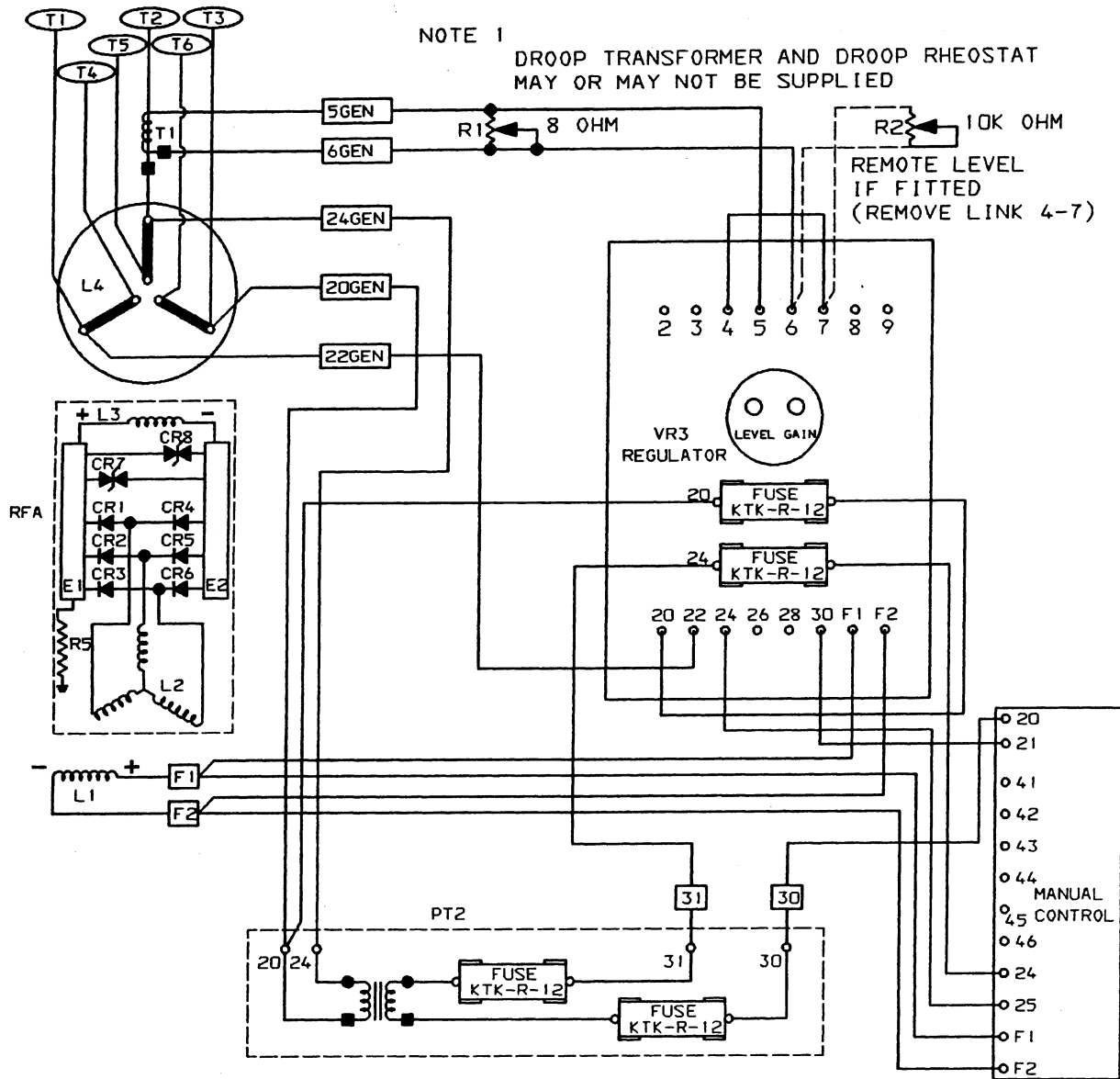

CR1-6 ROTATING RECTIFIERS
 CR7,8 SURGE SUPPRESSION DIODES
 E1 POSITIVE HEAT SINK
 E2 NEGATIVE HEAT SINK
 L1 EXCITER FIELD
 L2 EXCITER ARMATURE
 L3 ROTATING FIELD
 L4 STATOR

PT2 POWER TRANSFORMER ASSEMBLY
 R1 VOLTAGE DROOP RHEOSTAT (SEE NOTE 1)
 R2 REMOTE LEVEL RHEOSTAT
 R5 SUPPRESSION RESISTOR
 RFA REVOLVING FIELD ASS'Y
 T1 VOLTAGE DROOP TRANSFORMER (SEE NOTE 1)
 O TERMINAL BOARD NUMBER
 □ WIRE NUMBER
 ■ POLARITY MARKING

SR-4 GENERATOR SCHEMATIC (4/6 LEAD, SELF-EXCITED W/ POWER TRANSFORMER & MANUAL CONTROL)

NOTE : GENERATOR STATOR LEADS TERMINALS T4, T5, AND T6 WILL BE INTERNALLY CONNECTED TO FORM THE NEUTRAL LEAD (T0) ON FOUR LEAD GENERATORS.

C37576P1

C Manual Voltage Control Schematic With Power Transformer and Sensing

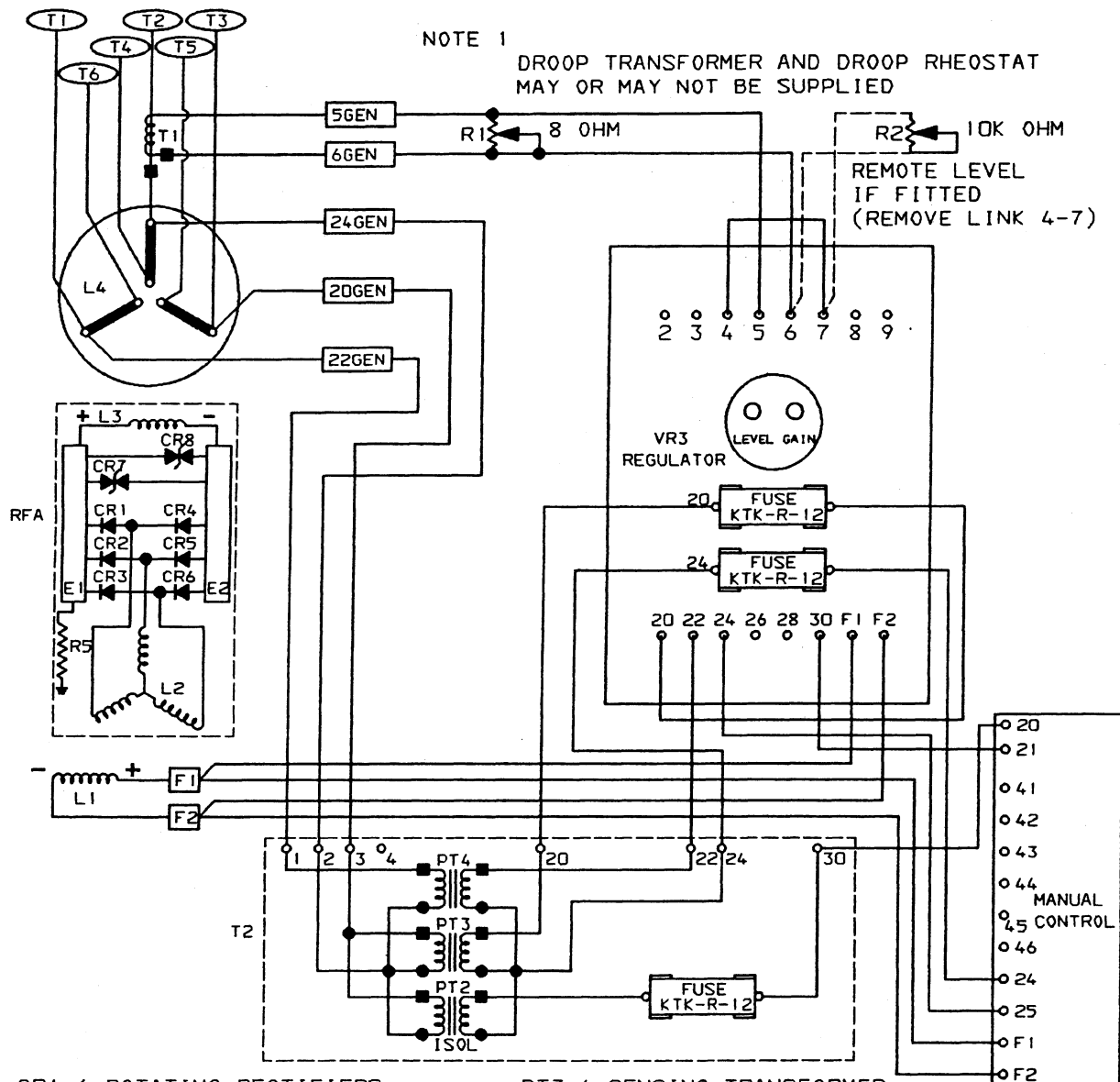

NOTE 1
 DROOP TRANSFORMER AND DROOP RHEOSTAT
 MAY OR MAY NOT BE SUPPLIED

- CR1-6 ROTATING RECTIFIERS
- CR7,8 SURGE SUPPRESSION DIODES
- E1 POSITIVE HEAT SINK
- E2 NEGATIVE HEAT SINK
- L1 EXCITER FIELD
- L2 EXCITER ARMATURE
- L3 ROTATING FIELD
- L4 STATOR
- PT2 POWER TRANSFORMER
- PT3,4 SENSING TRANSFORMER
- R1 VOLTAGE DROOP RHEOSTAT (SEE NOTE 1)
- R2 REMOTE LEVEL RHEOSTAT
- R5 SUPPRESSION RESISTOR
- RFA REVOLVING FIELD ASS'Y
- T1 VOLTAGE DROOP TRANSFORMER (SEE NOTE 1)
- T2 ISOLATION TRANSFORMER ASSEMBLY
- TERMINAL BOARD NUMBER
- WIRE NUMBER
- POLARITY MARKING

SR-4 GENERATOR SCHEMATIC (4/6 LEAD, SELF-EXCITED W/ SENSING AND POWER TRANSFORMER & MANUAL CONTROL)

NOTE : GENERATOR STATOR LEADS TERMINALS T4, T5, AND T6 WILL BE INTERNALLY CONNECTED TO FORM THE NEUTRAL LEAD (TO) ON FOUR LEAD GENERATORS.

C37575P1

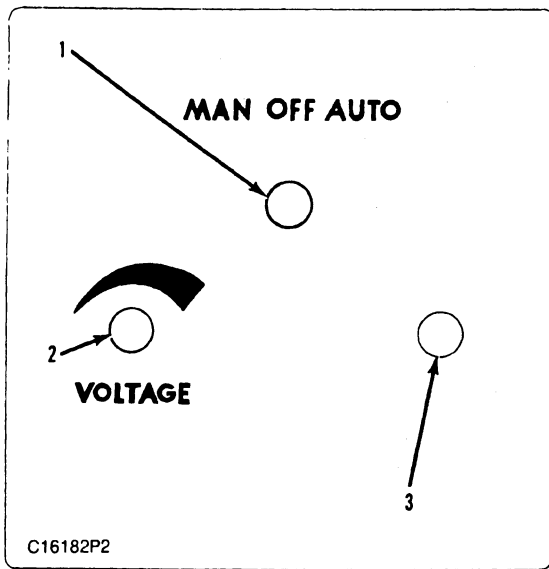

Manual Voltage Control Panel
 (1) Switch (OFF, AUTO and MAN positions). (2) Voltage control rheostat. (3) Fuse.

The manual voltage control can be used to control generator voltage when there is a failure in the generator regulator assembly. It will manually control the current flow to exciter stator L1.

The manual voltage control panel has switch (1) and voltage control rheostat (2) for the manual operating mode.

Switch (1) is used to make the selection between AUTO, MAN and OFF. In the "AUTO" position, the VR3 regulator controls the generator voltage. In the "OFF" position, the voltage will go to zero. In the "MAN" position, generator voltage is controlled by voltage control rheostat (2).

NOTE: The Manual Voltage Control Panel must not be installed in a location that is subject to engine vibrations or directly to outside weather.

NOTE: When the manual voltage control is operating in the "Manual" mode, it is not necessary for the VR3 regulator to be connected to the generator. However, the manual control must remain connected to generator sensing lines No. 20 and No. 24.

Voltage Droop Transformer And Adjustment Rheostat For Parallel Operation

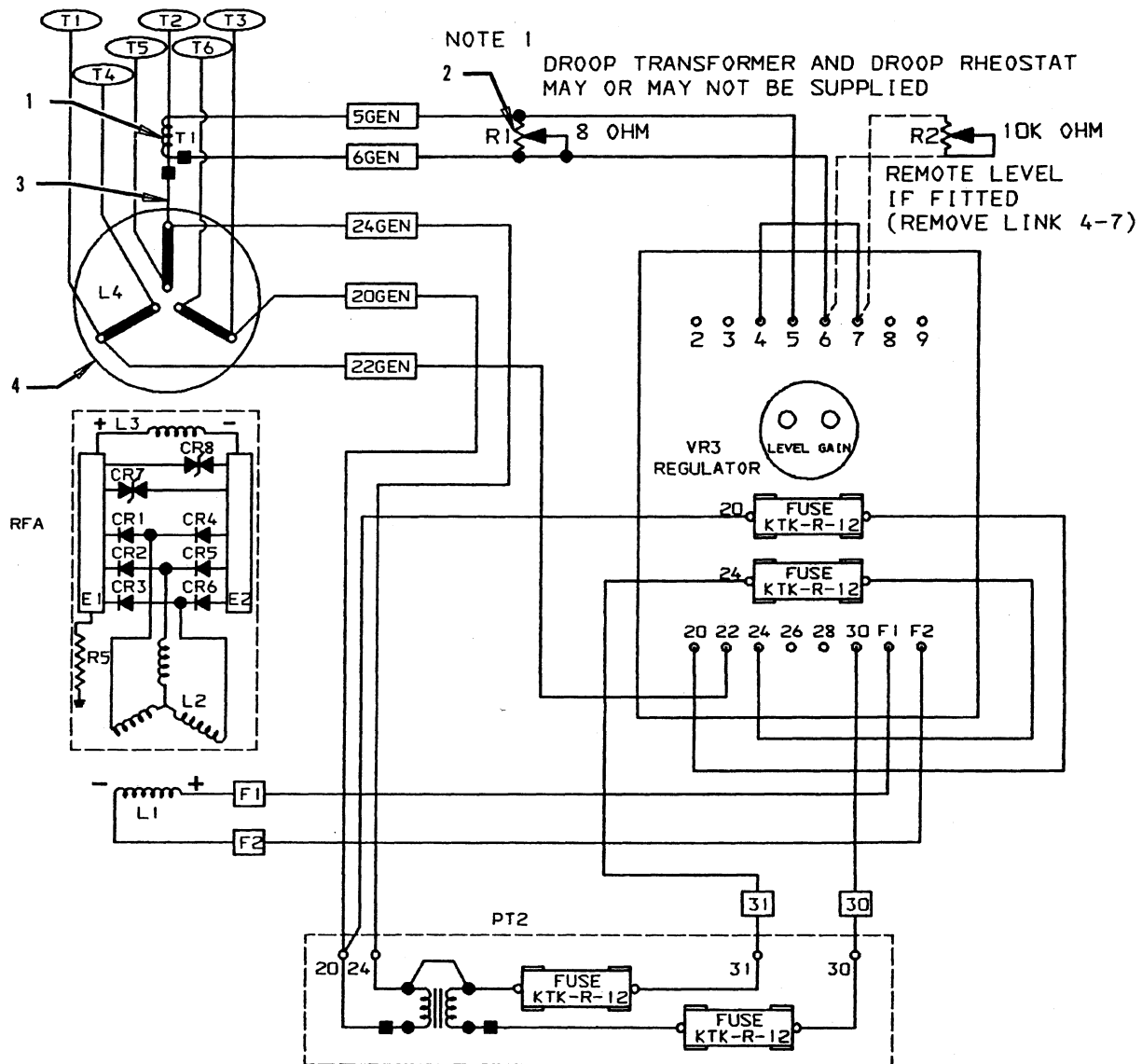

C37577P1

Generator And Regulator Schematic
(1) Voltage droop transformer. (2) Voltage droop rheostat. (3) Lead. (4) Main stator.

Operation of generators in parallel requires voltage droop as reactive load is increased. Droop transformer (1) and adjustment rheostat (2) are required to provide the voltage droop function. The transformer senses load current in lead (3) of main stator (4). Droop rheostat (2) provides adjustment of droop voltage. Rheostat (2) is located directly next to the regulator on the regulator mounting bracket.

Transformer (1) is standard on some generators and is an attachment on others. Rheostat (2) is an attachment on all units.

NOTE: Droop transformer (1) is a special ratio transformer.

NOTE: Droop transformer (1) must be installed on generator phase lead T2 with transformer polarity connections as shown.

CATERPILLAR®