

This document is best viewed at a screen resolution of 1024 X 768.

To set your screen resolution do the following:
RIGHT CLICK on the **DESKTOP**.
 Select **PROPERTIES**.
CLICK the **SETTINGS TAB**.
MOVE THE SLIDER under **SCREEN RESOLUTION** until it shows **1024 X 768**.
CLICK OK to apply the resolution.

The Bookmarks panel will allow you to quickly navigate to points of interest.

Open/Close Bookmark Panel

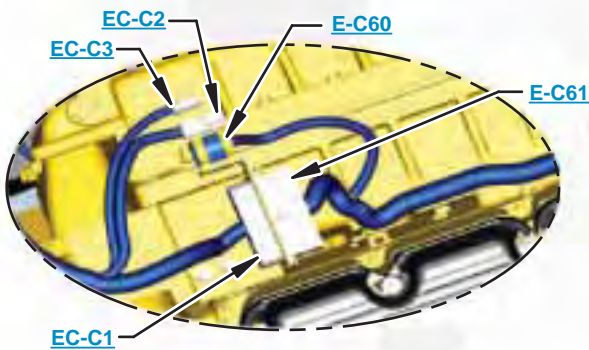

Click on any text that is BLUE and underlined. These are hyperlinks that can be used to navigate the schematic and machine views.

VIEW ALL CALLOUTS

When only one callout is showing on a machine view this button will make all of the callouts visible. This button is located in the top right corner of every machine view page.

HOTKEYS (Keyboard Shortcuts)		
	FUNCTION	KEYS
	Zoom In	"CTRL" / "+"
	Zoom Out	"CTRL" / "-"
	Fit to Page	"CTRL" / "0" (zero)
	Hand Tool	"SPACEBAR" (hold down)
	Find	"CTRL" / "F"



Schematic

3516C XQ2000 Power Module with Auto Paralleling System Electrical System

NAM1-UP

CONTROL PANEL (INTERIOR)

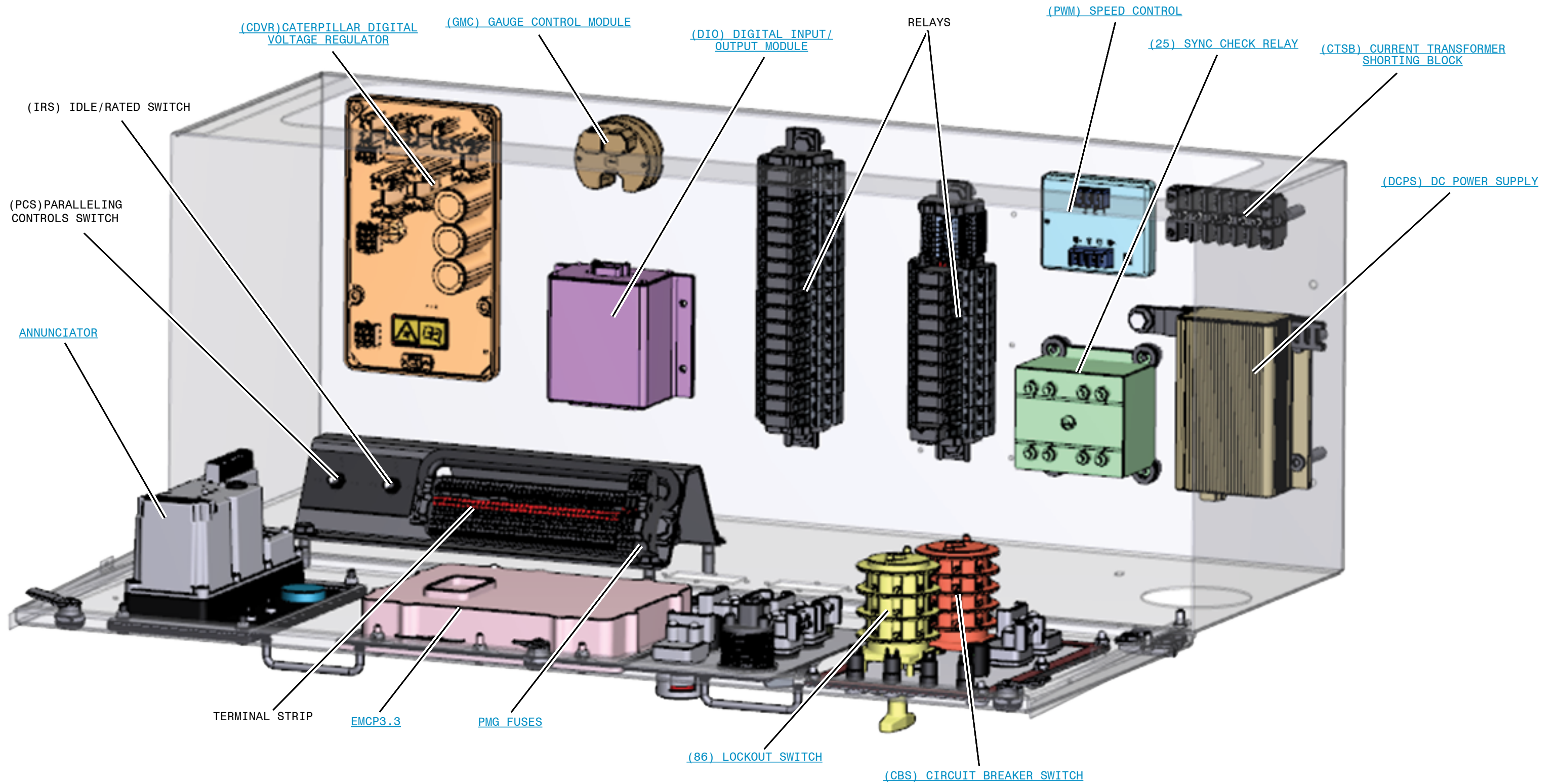

SHORE POWER DISTRIBUTION BOX

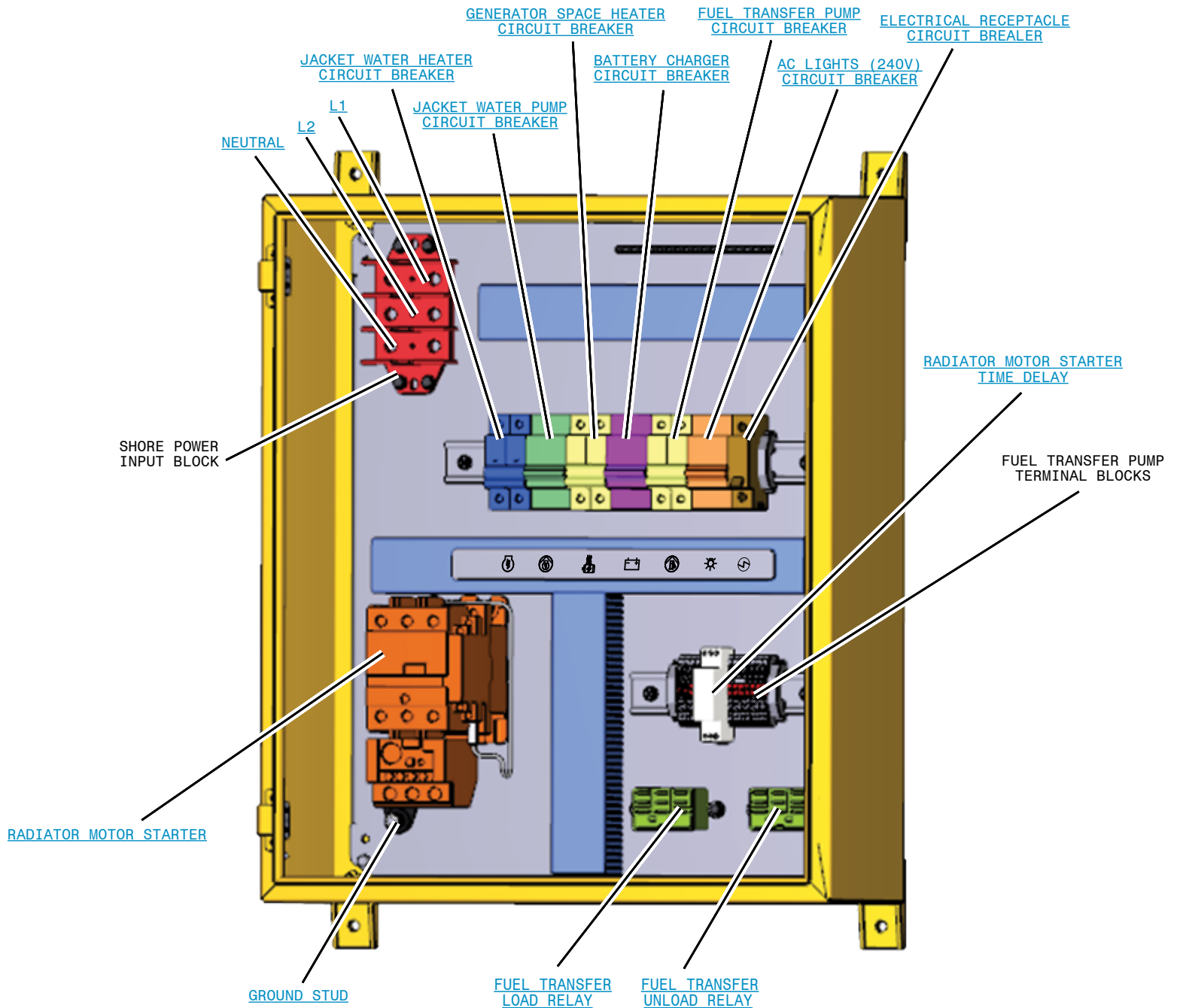

GENERATOR DOGHOUSE (FRONT VIEW)

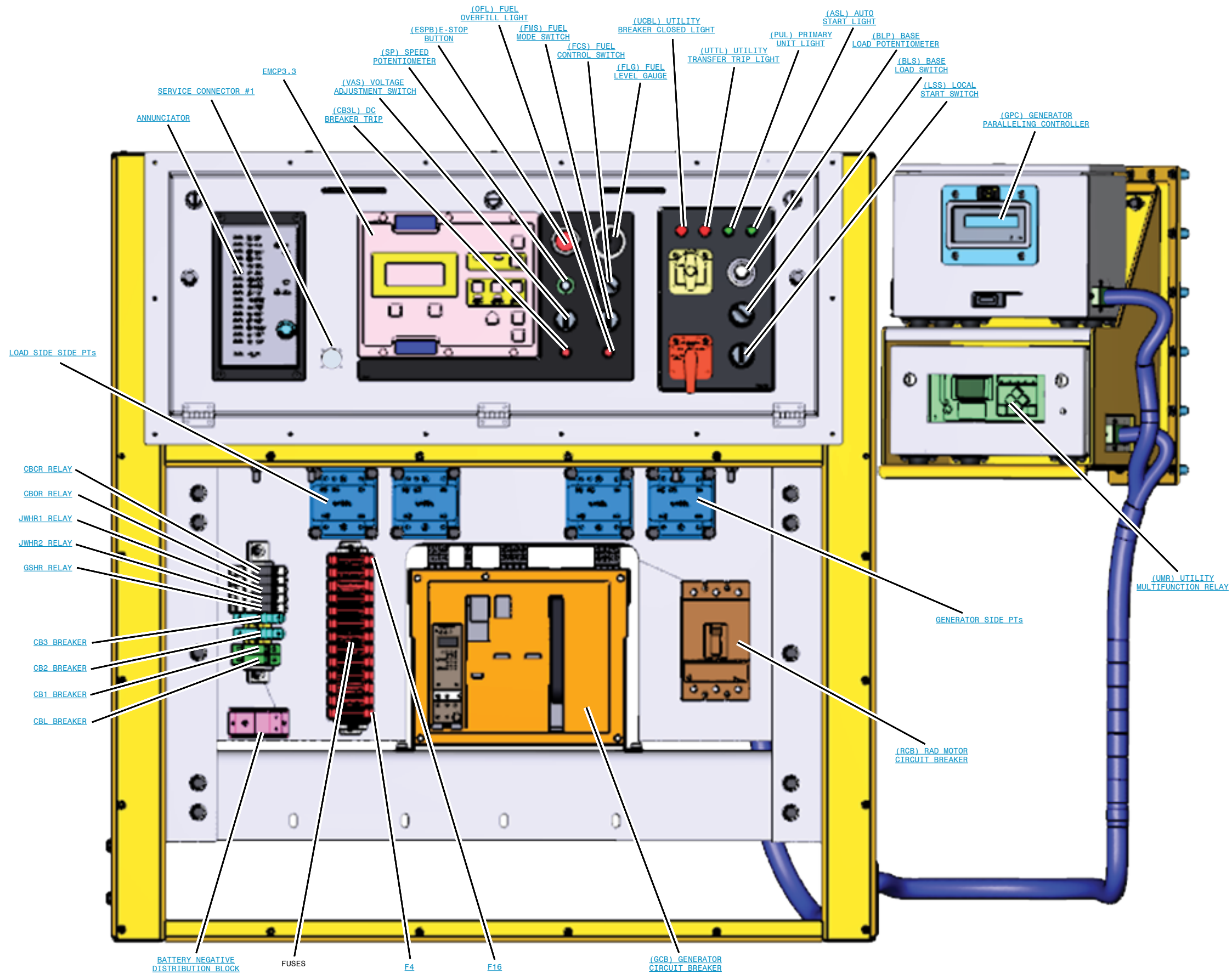

GENERATOR DOGHOUSE (REAR VIEW)

